

CDP-CX55

SERVICE MANUAL

*US Model
Canadian Model
AEP Model
UK Model
E Model
Australian Model
PX Model*



Model Name Using Similar Mechanism	CDP-CX50/CX571
CD Mechanism Type	CDM-46TE
Base Unit Type	KSM-213BFN/M-NP
Optical Pick-up Type	KSS-213B/S-N

SPECIFICATIONS

Compact disc player

Laser	Semiconductor laser ($\lambda = 780$ nm) Emission duration: continuous
Laser output	Max 44.6 μ W* * This output is the value measured at a distance of 200 mm from the objective lens surface on the Optical Pick-up block with 7 mm aperture.
Frequency response	2 Hz to 20 kHz \pm 1 dB
Signal-to-noise ratio	More than 107 dB
Dynamic range	More than 88 dB
Harmonic distortion	Less than 0.013 %
Channel separation	More than 100 dB

Outputs

	Jack type	Maximum output level	Load impedance
LINE OUT	Phono jacks	2 V (at 50 kilohms)	Over 10 kilohms
DIGITAL OUT (OPTICAL)	Optical output connector	-18 dBm	Wave length: 660 nm

General

Power requirements

Where purchased	Power requirements
USA/Canada	120 V AC, 60 Hz
AEP/UK/Singapore	220 V - 230 V AC, 50/60 Hz
Australia	240 V AC, 50/60 Hz
Other countries	110 V - 120 V or 220 V - 240 V AC, adjustable, 50/60 Hz

Power consumption 12 W

Dimensions (approx.) (w/h/d)
When the front cover is closed
430 \times 182.5 \times 295 mm (17 \times 7 1/4 \times 1 5/8 in.) incl. projecting parts
When the front cover is open
430 \times 182.5 \times 414 mm (17 \times 7 1/4 \times 16 3/8 in.) incl. projecting parts

Mass (approx.) 5.3 kg (11 lbs 11 oz)

Design and specifications are subject to change without notice.

COMPACT DISC PLAYER



SONY®

TABLE OF CONTENTS

1. SERVICING NOTE	3
2. GENERAL	6
3. DISASSEMBLY	
3-1. Front Panel	16
3-2. Illumination ASSY	16
3-3. CD Mechanism Deck	17
3-4. Base Unit and Magnet Holder	17
3-5. CD Mechanism Section	18
4. TEST MODE	19
5. MECHANICAL ADJUSTMENTS	22
6. ELECTRICAL ADJUSTMENTS	25
7. DIAGRAMS	
7-1. Circuit Boards Location	28
7-2. IC Block Diagrams	30
7-3. Block Diagrams	
• BD Section	33
• Main Section	35
7-4. Printed Wiring Board — BD Section —	37
7-5. Schematic Diagram — BD Section —	39
7-6. Printed Wiring Board — Audio Section —	41
7-7. Schematic Diagram — Audio Section —	43
7-8. Printed Wiring Board — Main Section —	45
7-9. Schematic Diagram — Main Section —	47
7-10. Printed Wiring Board — Display Section —	49
7-11. Schematic Diagram — Display Section —	51
7-12. Printed Wiring Board — Sensor, Motor Section —	53
7-13. Schematic Diagram — Sensor, Motor Section —	54
7-14. IC Pin Functions	55
8. EXPLODED VIEWS	
8-1. Case Section	59
8-2. Front Panel Section	60
8-3. Chassis Section	61
8-4. Mechanism Deck Section 1 (CDM-46TE)	62
8-5. Mechanism Deck Section 2 (CDM-46TE)	63
8-6. Optical Pick-up Section (KSM-213 BFN/M-NP)	64
9. ELECTRICAL PARTS LIST	65

MODEL IDENTIFICATION — BACK PANEL —

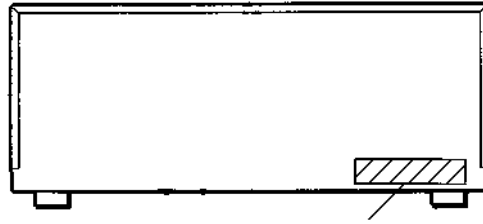

PARTS No.	MODEL
4-991-160-0□	US model
4-991-160-1□	Canadian model
4-991-160-2□	AEP model
4-991-160-3□	Australian model
4-991-160-4□	E, PX model
4-991-160-5□	Singapore model
4-991-160-6□	UK model

CAUTION

Use of controls or adjustments or performance of procedures other than those specified herein may result in hazardous radiation exposure.

The laser component in this product is capable of emitting radiation exceeding the limit for Class 1.

CLASS 1 LASER PRODUCT
LUOKAN 1 LASERLAITE
KLASS 1 LASERAPPARAT

This appliance is classified as a CLASS 1 LASER product. The CLASS 1 LASER PRODUCT MARKING is located on the rear exterior.

CAUTION	; INVISIBLE LASER RADIATION WHEN OPEN. AVOID EXPOSURE TO BEAM.
ADVARSEL	; USYNLIG LASERSTRÅLING VED ÅBNING NÅR SIKKERHEDSÅFBRYDERE ER UDE AF FUNKTION. UNDGÅ UDSÆTTELSE FOR STRÅLING.
VARO!	; AVATTAESSA JA SUOJALUKITUS OHITETTAESSA OLET ALTIINA LASERSÄTELYLLE.
VARNING	; LASERSTRÅLING NÅR DENNA DEL ÄR ÖPPNAD OCH SPÄRREN ÄR URKOPPLAD.
ADVARSEL	; USYNLIG LASERSTRÅLING NÅR DEKSEL ÅPNES UNGÅ EKSPONERING FOR STRÅLEN.

This caution label is located inside the unit.

For the customers in Canada

CAUTION

TO PREVENT ELECTRIC SHOCK,
DO NOT USE THIS POLARIZED AC
PLUG WITH AN EXTENSION
CORD, RECEPTACLE OR OTHER
OUTLET UNLESS THE BLADES
CAN BE FULLY INSERTED TO
PREVENT BLADE EXPOSURE.

SECTION 1 SERVICING NOTE

SAFETY CHECK-OUT

After correcting the original service problem, perform the following safety checks before releasing the set to the customer: Check the antenna terminals, metal trim, "metallized" knobs, screws, and all other exposed metal parts for AC leakage. Check leakage as described below.

LEAKAGE

The AC leakage from any exposed metal part to earth Ground and from all exposed metal parts to any exposed metal part having a return to chassis, must not exceed 0.5 mA (500 microamperes). Leakage current can be measured by any one of three methods.

1. A commercial leakage tester, such as the Simpson 229 or RCA WT-540A. Follow the manufacturers' instructions to use these instruments.
2. A battery-operated AC milliammeter. The Data Precision 245 digital multimeter is suitable for this job.
3. Measuring the voltage drop across a resistor by means of a VOM or battery-operated AC voltmeter. The "limit" indication is 0.75 V, so analog meters must have an accurate low-voltage scale. The Simpson 250 and Sanwa SH-63Trd are examples of a passive VOM that is suitable. Nearly all battery operated digital multimeters that have a 2V AC range are suitable. (See Fig. A)

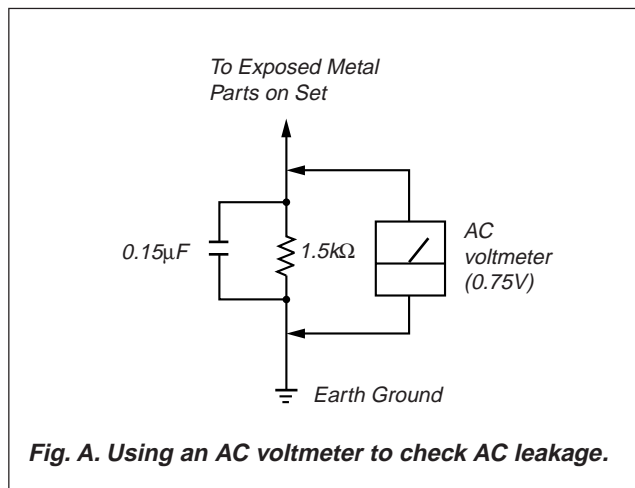

Fig. A. Using an AC voltmeter to check AC leakage.

NOTES ON HANDLING THE OPTICAL PICK-UP BLOCK OR BASE UNIT

The laser diode in the optical pick-up block may suffer electrostatic breakdown because of the potential difference generated by the charged electrostatic load, etc. on clothing and the human body. During repair, pay attention to electrostatic breakdown and also use the procedure in the printed matter which is included in the repair parts. The flexible board is easily damaged and should be handled with care.

NOTES ON LASER DIODE EMISSION CHECK

The laser beam on this model is concentrated so as to be focused on the disc reflective surface by the objective lens in the optical pick-up block. Therefore, when checking the laser diode emission, observe from more than 30 cm away from the objective lens.

LASER DIODE AND FOCUS SEARCH OPERATION CHECK

Carry out the "S curve check" in "CD section adjustment" and check that the S curve waveform is output repeatedly.

SAFETY-RELATED COMPONENT WARNING !!

COMPONENTS IDENTIFIED BY MARK \triangle OR DOTTED LINE WITH MARK \triangle ON THE SCHEMATIC DIAGRAMS AND IN THE PARTS LIST ARE CRITICAL TO SAFE OPERATION. REPLACE THESE COMPONENTS WITH SONY PARTS WHOSE PART NUMBERS APPEAR AS SHOWN IN THIS MANUAL OR IN SUPPLEMENTS PUBLISHED BY SONY.

ATTENTION AU COMPOSANT AYANT RAPPORT À LA SÉCURITÉ!!

LES COMPOSANTS IDENTIFIÉS PAR UNE MARQUE \triangle SUR LES DIAGRAMMES SCHÉMATIQUES ET LA LISTE DES PIÈCES SONT CRITIQUES POUR LA SÉCURITÉ DE FONCTIONNEMENT. NE REMPLACER CES COMPOSANTS QUE PAR DES PIÈCES SONY DONT LES NUMÉROS SONT DONNÉS DANS CE MANUEL OU DANS LES SUPPLÉMENTS PUBLIÉS PAR SONY.



CD-TEXT TEST DISC

This unit is able to display the test data (character information) written in the CD on its fluorescent indicator tube.

The CD-TEXT TEST DISC (TGCS-313:4-989-366-01) is used for checking the display.

To check, perform the following procedure.

Checking Method:

1. Turn ON the power, set the disc on the disc table with the side labeled as “test disc” as the right side, close the front cover, and chuck the disc.
2. Press the  button and play back the disc.
3. The following will be displayed on the fluorescent indicator tube.
Display : 1kHz/0 dB/ L&R
4. Press the  and  buttons to switch the track. The text data of each track will be displayed.
For details of the displayed contents for each track, refer to “Table 1 : CD-TEXT TEST DISC TEXT Data Contents” and “Table 2 : CD-TEXT TEST DISC Recorded Contents and Display”.

Restrictions in CD-TEXT Display

In this unit, some special characters will not be displayed properly. These will be displayed as a space or a character resembling it. For details, refer to “Table 2 : CD-TEXT DISC Recorded Contents and Display”.

Table 1 : CD-TEXT TEST DISC TEXT Data Contents (TRACKS No. 1 to 41:Normal Characters)

TRACK No.	Displayed Contents	TRACK No.	Displayed Contents
1	1kHz/0dB/L&R	22	1kHz/-90dB/L&R
2	20Hz/0dB/L&R	23	Infinity Zero w/o emphasis//L&R
3	40Hz/0dB/L&R	24	Infinity Zero with emphasis//L&R
4	100Hz/0dB/L&R	25	400Hz+7kHz(4:1)/0dB/L&R
5	200Hz/0dB/L&R	26	400Hz+7kHz(4:1)/-10dB/L&R
6	500Hz/0dB/L&R	27	19kHz+20kHz(1:1)/0dB/L&R
7	1kHz/0dB/L&R	28	19kHz+20kHz(1:1)/-10dB/L&R
8	5kHz/0dB/L&R	29	100Hz/0dB/L*
9	7kHz/0dB/L&R	30	1kHz/0dB/L*
10	10kHz/0dB/L&R	31	10kHz/0dB/L*
11	16kHz/0dB/L&R	32	20kHz/0dB/L*
12	18kHz/0dB/L&R	33	100Hz/0dB/R*
13	20kHz/0dB/L&R	34	1kHz/0dB/R*
14	1kHz/0dB/L&R	35	10kHz/0dB/R*
15	1kHz/-1dB/L&R	36	20kHz/0dB/R*
16	1kHz/-3dB/L&R	37	100Hz Squer Wave//L&R
17	1kHz/-6dB/L&R	38	1kHz Squer Wave//L&R
18	1kHz/-10dB/L&R	39	1kHz w/emphasis/-0.37dB/L&R
19	1kHz/-20dB/L&R	40	5kHz w/emphasis/-4.53dB/L&R
20	1kHz/-60dB/L&R	41	16kHz w/emphasis/-9.04dB/L&R
21	1kHz/-80dB/L&R		

NOTE : The contents of Track No. 1 to 41 are the same as those of the current TEST DISC-their titles are displayed.

Table 2: CD-TEXT TEST DISC Recorded Contents and Display
(In this unit, some special characters cannot be displayed. This is no a fault.)

TRACK No.	Recorded contents	Display
42	! " # \$ % & ' (21h to 27h)1kHz 0dB L&R	← All the same
43	() * + , - . / (28h to 2Fh)	← All the same
44	0 1 2 3 4 5 6 7 (30h to 37Fh)	← All the same
45	8 9 : ; < = > ? (38h to 3Fh)	← All the same
46	@ A B C D E F G (40h to 47Fh)	← All the same
47	H I J K L M N O (48h to 4Fh)	← All the same
48	P Q R S T U V W (50h to 57Fh)	← All the same
49	X Y Z [¥] ^ _ (58h to 5Fh)	X Y Z [/] ^ _ (58....
50	` a b c d e f g (60h to 57Fh)	← All the same
51	h i j k l m n o (68h to 6Fh)	← All the same
52	p q r s t u v w (70h to 77Fh)	← All the same
53	x y z { } ~ ■ (78h to 7Fh)	x y z { } ~ ■ (78....
54	■ i ç £ ¤ ¥ ¦ § (A0h to A7h) 8859-1	i ç £ ¤ ¥ ¦ § (A0.... ■ is not displayed
55	♪ ©ª « ¬ ® ¯ (A8h to AFh)	♪ (A8.... ©ª « ¬ ® ¯ are not displayed
56	• ± ² ³ ´ µ ¶ • (B0h to B7h)	´ µ • (B0.... • ± ² ³ ¶ are not displayed
57	† † ° » ¼ ½ ¾ ¿ (B8h to BFh)	† ¿ (B8.... † ° » ¼ ½ ¾ are not displayed
58	À Á Â Ã Ä Å Æ Ç (C0h to C7Fh)	← All the same
59	È É Ê Ë Ì Í Î Ï (C8h to CFh)	← All the same
60	Ð Ñ Ò Ó Ô Õ Ö × (C0h to C7Fh)	← All the same
61	Ø Ù Ú Û Ü Ý Þ ß (D8h to DFh)	⊘ Ù Ú Û Ü Ý Þ ß (D8....
62	à á â ã ä å æ ç (E0h to E7Fh)	← All the same
63	è é ê ë ì í î ï (E8h to FFh)	← All the same
64	đ ñ ò ó ô õ ö ÷ (F0h to F7Fh)	đ ñ ò ó ô õ ö ÷ (F0....
65	ø ù ú û ü ý þ ÿ (F8h to FFFh)	← All the same
66	No.66	← All the same
67	No.67	← All the same
to	to	to
99	No.99	← All the same

SECTION 2 GENERAL

LOCATION OF PARTS AND CONTROLS

Front Panel

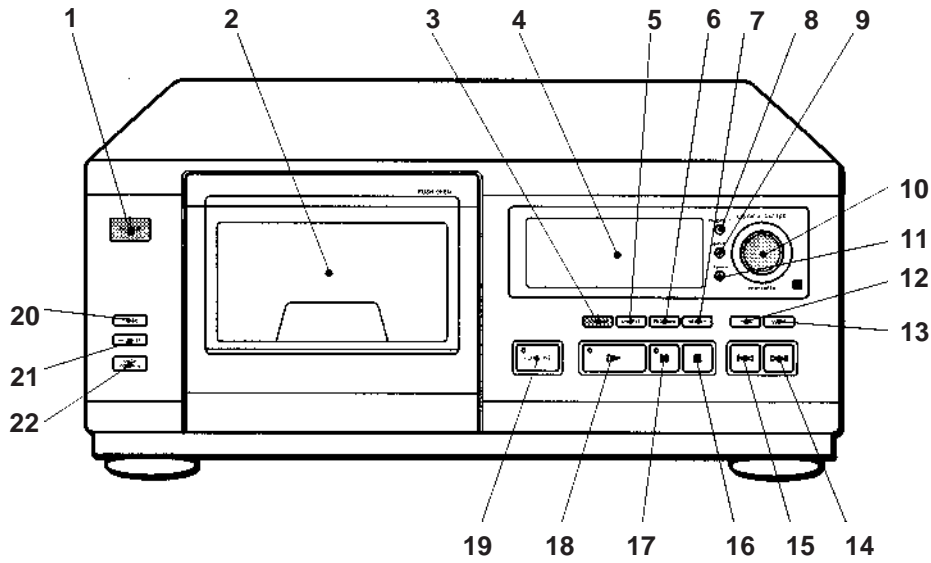

- | | |
|-----------------------------------|------------------------|
| 1 POWER switch | 12 CHECK button |
| 2 Front cover | 13 CLEAR button |
| 3 CONTINUE button | 14 ▷◁ button |
| 4 Display window | 15 ◀◀ button |
| 5 SHUFFLE button | 16 ■ button |
| 6 PROGRAM button | 17 ■■ button |
| 7 REPEAT button | 18 ▷ button |
| 8 TIME/TEXT button | 19 PLUS ONE button |
| 9 INPUT button | 20 X-FADE button |
| 10 DISC/CHARACTER/PUSH ENTER knob | 21 NO DELAY button |
| 11 SEARCH button | 22 MEGA CONTROL button |

This section is extracted from instruction manual.

What cords will I need?

- Audio cord (1) (Use the cord supplied with the player to be connected.)
- CONTROL A1 cord (1) (not supplied)

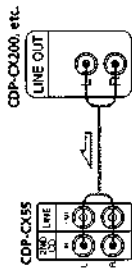

1 Connect the players with an audio cord (see also "Hook-ups" on Page 5).

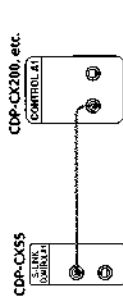

2 Connect the players with a CONTROL A1 cord.
For details on this connection, refer to the supplementary "CONTROL-A1 Control System" instructions.

3 Set the COMMAND MODE selector of each player.
Set the COMMAND MODE selector of this player to CD 1 or CD 2, and set that of the second player to CD 3.

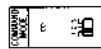

4 Connect the AC power cord of both players to AC outlets.

For details on how to operate the second player, see "Controlling Another CD Player" on page 20 and "Playing Alternately" on page 21.

Notes

- Do not connect a player other than that you use as the second player to the 2ND CD IN jacks of this player.
- When connecting a second CD player, do not connect the DIGITAL OUT (OPTICAL) connector of this unit to the amplifier

Connecting Another CD Player

If you have a Sony CD player equipped with the CONTROL A1 jack and the command mode of that player can be set to CD 3, you can control that player as the second player with this unit. After connecting this unit and an amplifier, follow the procedure below. Be sure to turn off the power of each player before making this connection.

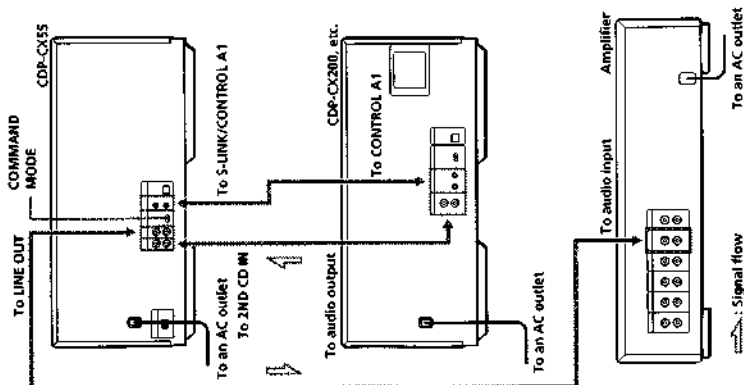

Getting Started

Inserting CDs

You can insert up to 51 discs into this player.

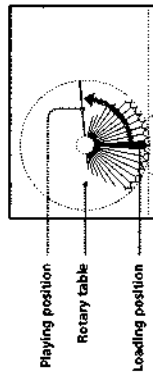
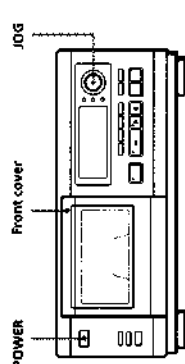

- 1 Press **POWER** to turn on the player.
- 2 Open the front cover by pushing the right edge of the cover.

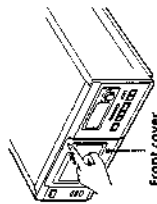

- 3 Turn the **JOG** dial until you find the disc slot where you want to insert a disc, while checking the disc number (written beside every slot and also indicated in the display).

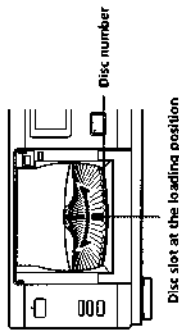

Disc slot at the loading position

The disc number at the loading position appears in the display.* If the disc has the Disc Memo (see page 22), the Disc Memo appears instead of the disc number. As you turn the **JOG** dial, the disc number or the Disc Memo changes.

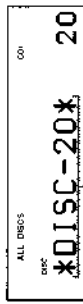

Disc number or the Disc Memo

You can play the disc you want independently by using the **Plus One** function. When using this function, insert the disc into the **PLUS ONE** slot. For details, see "Playing Your Favorite Disc Independently" on page 19.

- * If you have already inserted discs, the disc number at the playing position appears. When you turn the **JOG** dial, the displayed disc number changes to the one at the loading position.

(Continued)

Getting Started

- 4 Insert a disc with the label side facing right:

Notes

- Make sure you have inserted the disc into each slot at a right angle to the rotary table. If the disc is not put in straight, it may damage the player or the disc.
- Make sure the rotary table comes to a complete stop before inserting or removing discs.

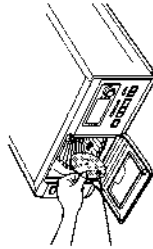

With the label side facing right

After inserting the disc, you can input the original disc titles instead of the disc numbers (see "Labeling Discs" on page 22) to locate it easily when you start playing.

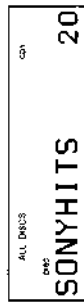

- 5 Repeat Steps 3 and 4 to insert more discs.
- 6 Close the front cover by pushing the right edge of the cover until it clicks.

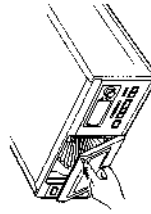

The rotary table turns and the disc slot at the loading position is set to the playing position. Always close the front cover except when you insert or remove discs.

- The supplied CD booklet holder helps you locate a disc.

You can store up to 50 CD booklets.

Notes

- Do not insert an empty 8 cm (3-inch) CD adaptor (CSA-8), it may damage the player.
- Do not attach anything such as seals or sleeves to CDs. It may damage the player or the disc.
- If you drop a disc into the player and the CD won't go into the slot correctly, consult your nearest Sony dealer.
- When transporting the player, remove all discs from the player.

Removing CDs

After following Steps 1 to 3 of "Inserting CDs" on page 7, remove the discs. Then close the front cover.

Note

The disc being played does not come to the loading position if you open the front cover during playback. (The disc number flashes in the display.)

If you want to remove the disc being played, push the JOG dial after opening the front cover. The disc comes to the loading position. Remove the disc after the rotary table comes to a complete stop.

Using the Display

You can check information about the disc using the display.

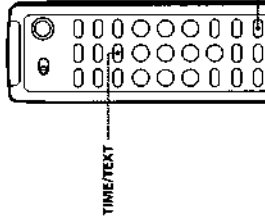
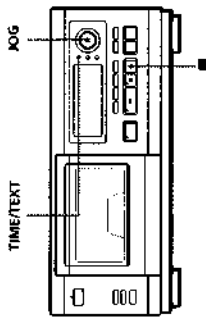

Checking the total number and playing time of the tracks

Select the disc you want to check, and push the JOG dial in the Continuous Play mode. As the player starts play automatically, press **■** to stop, and then TIME/TEXT.

The display shows the current disc number, total number of tracks and total playing time of the disc.

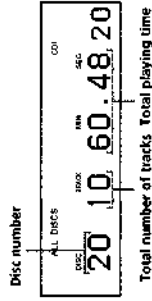

When you want to check another disc. Press DISC SKIP on the remote in the stop mode to select the disc you want to check. The total number of tracks and the total playing time of the selected disc appear for a while.

Display information while playing a disc

While playing a disc, the display shows the current disc number, track number, playing time of the track and the next disc number.

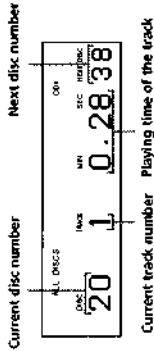

Checking the information of CD-TEXT discs

CD-TEXT discs have information, such as the disc titles or artist names, memorized in a blank space on the discs where there is no information on normal discs. The display shows the CD-TEXT information of the disc so that you can check the current disc title, track title and artist name. When you select a CD-TEXT disc, the "CD-TEXT" indication lights up in the display.

Display information before you start playing

The display shows the disc title. When you press TIME/TEXT, the artist name scrolls in the display. If you press TIME/TEXT again, the display shows the current disc number, total number of tracks and total playing time of the disc. The display shows the disc title again after a while.

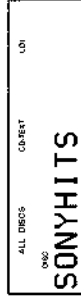

Locating a Specific Disc

Display information while playing a disc
Each time you press **TIME/TEXT**, the display shows the information as shown below.

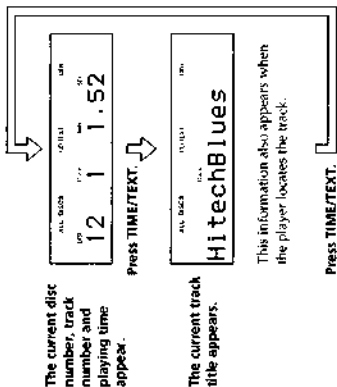

The current disc number, track number and playing time appear.

The current track title appears.

This information also appears when the player locates the track.

Press **TIME/TEXT**.

To play disc highlights

Some CD-TEXT discs have a feature to play only the highlights of the discs. Press **HIGH-LIGHT** on the remote to start playing disc highlights in the stop mode. The indicator on the **DISC** button flashes while playing disc highlights. If you press **HIGH-LIGHT** while selecting discs without this feature, "NO HIGHLIGHT" appears in the display.

Selecting a disc on the player

Turn the **JOG** dial until the disc number or Disc Memo (see page 22) you want appears in the display. Push the **JOG** dial to start play.

Selecting a disc directly using the remote

- 1 Press **DISC**.
- 2 Press the number button of the disc.
Example: To enter number 25
Press >10 first, then 3 and 5.
- 3 Press **ENTER** to start play.

Locating a disc by scanning each Disc Memo (Memo Scan)

You can locate a disc you want to play quickly by scanning the Disc Memos (see page 22) in the display and start playing.

Note that you cannot use this function in the ALL DISCS Shuffle Play mode.

- 1 Press **MEMO SCAN**.
"MEMO SCAN" appears in the display, and the Disc Memos scroll in the display.
- 2 Press **DISC** when the Disc Memo of the disc you want to play appears.
The disc is set to the playing position, and the player starts playing.
In Program Play mode, the disc will be added to the end of the program if you press **ENTER** instead of **DISC**.

Note

If "NO ENTRY" appears in the display, no disc has been labeled with the Disc Memo. Try the Memo Scan function again after labeling the discs.

Locating a disc by searching a specific Disc Memo (Memo Search)

You can search and locate a disc you want by inputting the first character used in the Disc Memo (see page 22).

- 1 Press **SEARCH**.
"MEMO SEARCH" appears in the display.
- 2 Press **F4<math>/math>/P<math>/math>H** repeatedly to input the first character.

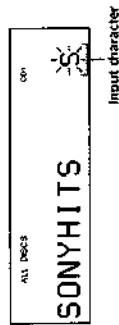

Each time you press **F4<math>/math>/P<math>/math>H**, the characters appear in the following order:

A B C D E F G H I J K L M N O P Q R S T U V W X
Y Z 0 1 2 3 4 5 6 7 8 9

If "NOT FOUND" appears in the display while inputting the first character with the **F4<math>/math>/P<math>/math>H** buttons, no disc has been labeled using the input character.

Notes

- When searching input characters, blanks and symbols before the first character in the Disc Memo are ignored.
- When searching input characters, upper and lower cases cannot be differentiated.

- 3 Turn the **JOG** dial to find the disc you want.
As you turn the **JOG** dial, the Disc Memos starting with the input character appear in the display.

- 4 Push the **JOG** dial to select the disc.
In Program Play mode, the disc will be added to the end of the program.

To cancel Memo Search
Press **SEARCH** again.

If there is no more Disc Memo starting with the input character in Stop 3
The input character changes to the next one when you turn the **JOG** dial.

Playing Repeatedly

You can play discs/tracks repeatedly in any play mode.

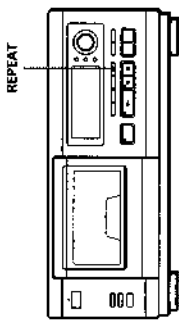

Press REPEAT while playing a disc. "REPEAT" appears in the display. The player repeats the discs/tracks as follows.

When the disc is played in	The player repeats
ALL DISCS Continuous Play (page 10)	All tracks on all discs
1 DISC Continuous Play (page 10)	All tracks on the current disc
ALL DISCS Shuffle Play (page 16)	All tracks on all discs in random order
1 DISC Shuffle Play (page 16)	All tracks on the current disc in random order
Program Play (page 17)	The same program

To cancel Repeat Play
Press REPEAT repeatedly until "REPEAT OFF" appears in the display.

Repeating the current track

You can repeat only the current track.

While the track you want is being played, press REPEAT repeatedly until "REPEAT 1" appears in the display.

Specifying the Next Disc to Play

You can specify the next disc to play while playing a disc in Continuous or 1 DISC Shuffle Play mode.

While playing a disc, turn the JOG dial until the disc number or Disc Memo (see page 22) you want appears in the display.



After the current disc is played, the next disc you have specified starts playing. If you want to skip to the next disc right away, push the JOG dial while playing the current disc.

To cancel the disc you have specified
Press CONTINUE twice.

Locating a Specific Track or a Point in a Track

You can quickly locate any track while playing a disc using the FWD/DBA (AMS: Automatic Music Sensor) buttons or number buttons on the remote. You can also locate a specific point in a track while playing a disc.

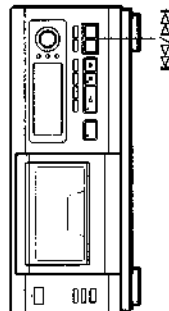

Playing in Random Order (Shuffle Play)

You can have the player "shuffle" the tracks and play in random order. The player shuffles all the tracks on all discs or on the disc you specified.

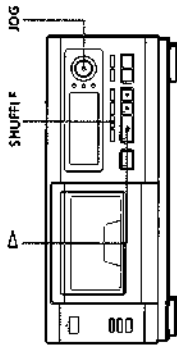

1 Press SHUFFLE to select ALL DISCS or 1 DISC Shuffle Play mode. Each time you press SHUFFLE, "ALL DISCS" or "1 DISC" appears in the display.

When you select	The player plays
ALL DISCS	All tracks on all discs in random order
1 DISC	All tracks on the specific disc in random order

2 When you want to specify the disc for 1 DISC Shuffle Play, turn the JOG dial until the disc number or Disc Memo (see page 22) you want appears in the display.

3 Push the JOG dial or press Δ. ALL DISCS or 1 DISC Shuffle Play starts. "SHUFFLE" appears in the display while the player is "shuffling" the discs or the tracks.

To cancel Shuffle Play
Press CONTINUE

You can start Shuffle Play while playing
Press SHUFFLE, and Shuffle Play starts from the current track.

You can directly select a disc for 1 DISC Shuffle Play
See "Selecting a disc directly using the remote" on page 13.

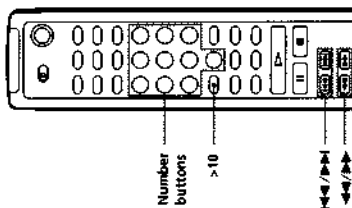

To locate

the next or succeeding tracks	DBA repeatedly until you find the track
the current or preceding tracks	FWD repeatedly until you find the track
a specific track directly	Number button of the track on the remote
a point in a track while monitoring the sound	Δ (backward) or Δ (forward) on the remote and hold down until you find the point
a point in a track quickly by observing the display	Δ (backward) or Δ (forward) on the remote and hold down until you find the point during pause. You will not hear the sound during the operation

You can directly locate a track numbered over 10
Press >10 first, then the corresponding number buttons on the remote.

Note
If "OVER" appears in the display, the disc has reached the end while you were pressing Δ. Press Δ or FWD to go back.

You can go to the next disc during 1 DISC Shuffle Play 
Press DISC SKIP +.

You can specify the next disc to play during 1 DISC Shuffle Play
Turn the JOG dial to specify the next disc. After all the tracks on the current disc are played in random order, the next disc starts playing. If you want to skip to the next disc right away, push the JOG dial while playing the current disc.

Notes

- You cannot specify the next disc to play during ALL DISCS Shuffle Play.
- Even if you press  or turn off the player during ALL DISCS Shuffle Play, the player remembers which discs/tracks were played and which were not. Therefore, if you want to start ALL DISCS Shuffle Play again from the beginning, be sure to repeat the procedure from Step 1.

Creating Your Own Program (Program Play)

You can arrange the order of the tracks and/or discs to create three different programs and programs are stored automatically. Each program (PROGRAM 1, 2 or 3) can contain up to 32 "steps" — one "step" may contain a track or a whole disc. You can make programs using the controls on the remote as well as ones on the player. However, the programming procedures are different.

Creating a program on the player

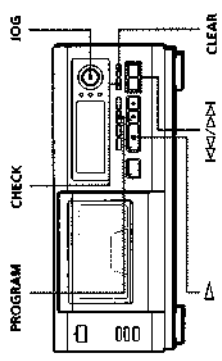

1 Press PROGRAM until the program number you want (PROGRAM 1, 2 or 3) appears in the display. If a program is already stored in the selected program number, the last step of the program appears in the display. When you want to erase the whole program, hold down CLEAR until "ALL CLEAR" appears in the display (see page 19).

2 Turn the JOG dial until the disc number you want appears in the display.



3 To program a whole disc, skip this step. Press H-CL/P-DH until the track number you want appears in the display.

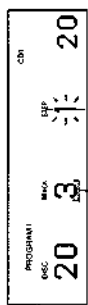

4 Push the JOG dial or press PROGRAM.

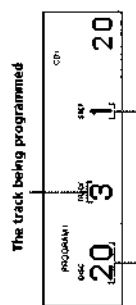

5 To program other discs/tracks, do the following:

To program	Repeat Steps
Other discs	2 and 4
Other tracks on the same disc	3 and 4
Other tracks on other discs	2 to 4

6 Press  to start Program Play.

To cancel Program Play
Press CONTINUE.

The programs remain even after Program Play ends
When you press , you can play the same program again.

When you press PROGRAM during Continuous or Shuffle Play
The program will be played after the current track.

The programs remain until you erase them
If you replace discs, the programmed disc and track numbers remain. So, the player plays only the existing disc and track numbers. However, the disc and track numbers that are not found in the player or on the disc are deleted from the program, and the rest of the program is played in the programmed order.

Creating a program using the remote

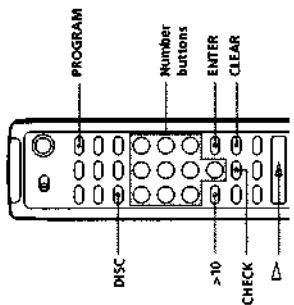

1 Press PROGRAM until the program number you want (PROGRAM 1, 2 or 3) appears in the display.

2 Press DISC.

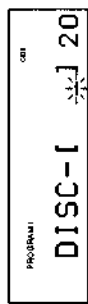

3 Press the number button of the disc.

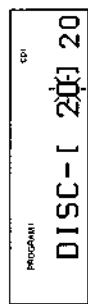

4 To program a whole disc, skip this step and go to Step 6. Press >10.



5 Press the number button of the track.
The number you pressed is entered into the flashing digit.



6 Press ENTER.

The disc being programmed

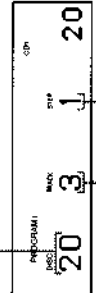

7 To program other discs/tracks, do the following:

To program	Repeat Steps
Other discs	2, 3 and 6
Other tracks on the same disc	4 to 6
Other tracks on other discs	2 to 6

8 Press  to start Program Play.

To cancel Program Play
Press CONTINUE.

Checking the programmed order

You can check your program before or after you start playing.

Press CHECK.
Each time you press this button, the display shows the disc and track number of each step in the programmed order. (When a whole disc is programmed as one step, "ALL" appears instead of the track number.) After the last step in the program, the display shows "END" and returns to the original display.

Changing the programmed order

You can change your program before you start playing.

To	You need to
Erase a track or disc	Press CHECK until the track or disc you do not want appears in the display, then press CLEAR.
Erase the last track or disc in the program	Press CLEAR. Each time you press the button, the last track or disc will be erased.
Add tracks or discs to the end of the program	Follow the programming procedure.
Change the whole program completely	Hold down CLEAR until "ALL CLEAR" appears in the display to erase the whole program, then create a new program following the programming procedure.

Erasing the programs stored in memory

- 1 Press PROGRAM repeatedly in the stop mode until the program number (PROGRAM 1, 2 or 3) you want to erase appears in the display.
- 2 Hold down CLEAR until "ALL CLEAR" appears in the display.

Looping Part of a Disc (Loop)

You can repeat part of a disc during playback. This function lets you create original recordings.

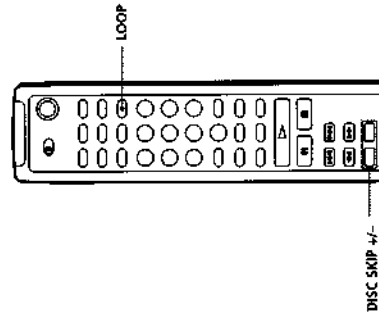

Press and hold LOOP during playback at the point you want to start the Loop function, and release to resume normal play.

To adjust the loop length

Press DISC SKIP +/- while holding LOOP on the remote to select different loop lengths (LOOP 1-30).

Playing Your Favorite Disc Independently (Plus One Play)

When you insert a disc into the PLUS ONE slot, you can play the disc independently from other discs. When using this function, the player is automatically set to 1 DISC Continuous Play mode.

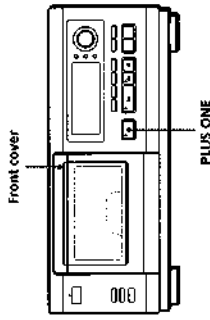

- 1 Open the front cover.
- 2 Press PLUS ONE. The indicator on the PLUS ONE button lights up.

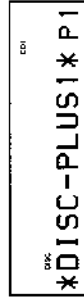

The PLUS ONE slot comes to the loading position.

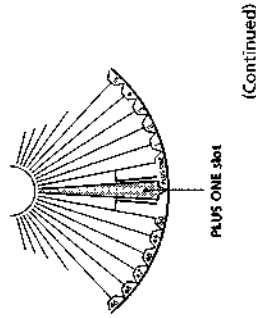

(Continued)

Controlling Another CD Player (Mega Control)

This unit can control a second CD player (see "Connecting Another CD Player" on page 6). Even when a second CD player is connected, the controls on both of the units will function. When you press the play button on either unit, the operating player stops and the resting player starts. Make sure "2nd DETECTED" appears in this player's display after turning on both players.

The controls indicated in the illustration below are effective while the MEGA CONTROL button is lit.

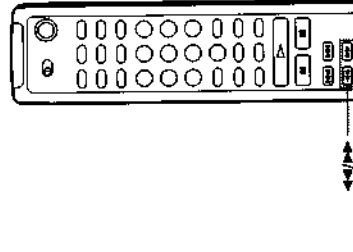
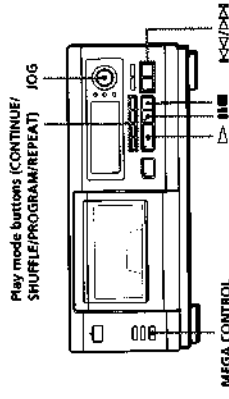

- 1 Press MEGA CONTROL on this player. The MEGA CONTROL button and "2nd" in the display light up. The display shows the current disc number of the second player.

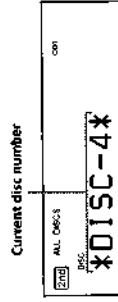

- 3 Insert a disc into the PLUS ONE slot.

- 4 Close the front cover. "P1" appears in the display instead of the disc number, and the player starts playing the disc in the PLUS ONE slot.



To cancel Plus One Play

Press PLUS ONE. The indicator on the PLUS ONE button goes off. The disc number in the display changes to 51 and you can play the disc as the 51st disc.

- 4 If you have already inserted a disc into the PLUS ONE slot
 - Press PLUS ONE while the front cover is closed. Plus One Play starts immediately.

You can select Shuffle Play mode during Plus One Play

Press SHUFFLE before Step 4 above.

Notes

- Plus One Play will be canceled if you turn the JOG dial or press buttons to specify the other disc.
- Plus One Play will be canceled if you press the PROGRAM button.
- The PLUS ONE slot comes to the loading position automatically if you open the front cover during Plus One Play. Do not put your hand inside the compartment nor change the disc before the rotary table comes to a complete stop. If you do, you may injure your hand or damage the disc.

2 Select the play mode you want. To program tracks, use the controls on the second player.

3 Press **▶** on this player to start playing. The play starts and the display shows the current disc and track numbers and the playing time of the track. While the MEGA CONTROL button is lit, you can control the second player with the controls on this player.

To control the second player directly using the supplied remote
Set CD 1/2/3 on the remote to CD 3 which is the same position as the COMMAND MODE selector on the rear panel of the second player.

To control this player again
Press MEGA CONTROL. The MEGA CONTROL button goes off and you can control this player

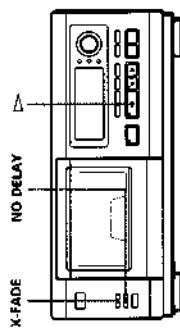

1 Select the play mode you want on each player.

2 When you select **No-Delay Play**

Press **NO DELAY**.

"NO DELAY" appears in the display.

When you select **X-Fade Play**

Press **X-FADE**.

"X-FADE" appears in the display.

Each time you press the X-FADE button, the

indication appears as follows:

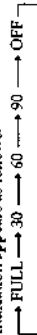

To change the current player each time a whole track is finished, select "FULL."

To change the current player at the specified interval, press X-FADE repeatedly until the interval you want appears in the display.

3 Press **▶** to start playing. The MEGA CONTROL button lights up while the track in the second player is selected.

To cancel No-Delay/X-Fade Play

Press the corresponding button repeatedly until "NO DELAY" or "X-FADE" disappears from the display. The current player continues playing.

You can change the method (No-Delay or X-Fade) during play

Press the corresponding button (NO DELAY or X-FADE) following the procedure in Step 2 above.

Notes

- The play starts from the second player if you start play while the MEGA CONTROL button is lit.
- When one player has played all the discs/tracks in the player ahead of the other player, the play stops.
- Do not use the controls on the second player during No-Delay/X-Fade Play. They may not work correctly.

What You Can Do With the Custom Files

The player can store two types of information called "Custom Files" for each disc. Once you have stored Custom Files for a disc, the player automatically recalls what you have stored whenever you select the disc. Note that Custom Files will be erased if you do not use the player for about one month.

You can store this information:

When you use	You can
Disc Memo (page 29)	Label discs using up to 12 characters
Delete Bank (page 29)	Delete unwanted tracks and store only the tracks you want

Where are Custom Files stored?

Custom Files are stored not on the disc, but in the player's memory. It means you cannot use Custom Files when you play the disc on other players.

If you replace discs you have filed in the Custom Files

The Custom File information you have stored remains, since each Custom File information is assigned to each slot. Erase all Custom Files (Disc Memo and Delete Bank) of the old disc, and then file the new disc information in the Custom Files.

Erasing all Custom Files of all discs

Turn off the player. While holding down **CLEAR**, press **POWER** to turn on the player. "ALL ERASE" appears in the display, and all Custom Files will be erased.

Labeling Discs (Disc Memo)

You can label discs using up to 12 characters and have the player display the Disc Memo each time you select the disc. The Disc Memo can be anything you like, such as a title, musician's name, category or date of purchase.

When you select a CD-TEXT disc

The disc title is stored as the Disc Memo automatically. If the disc title has more than 12 characters, the first 12 characters of the disc title are stored (see page 12). When you replace a disc with a CD-TEXT disc, the disc title of the CD-TEXT disc is also stored automatically. Note that you cannot change the Disc Memo of the CD-TEXT disc.

You can label discs while the front cover is open

Labeling discs on the player

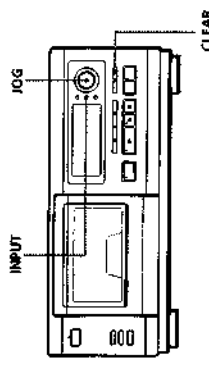

1 Turn the **JOG** dial until the disc number in which you want to assign a Disc Memo appears in the display.

When you label a disc with the front cover closed, the disc number of the disc at the playing position appears.

When you label a disc with the front cover open, the disc number at the loading position appears.

2 Press **INPUT**.

The flashing cursor (◀) appears.

- 3** Turn the JOG dial until the character you want appears in the display. The cursor disappears and the first space for the Disc Memo flashes. As you turn the JOG dial clockwise, the characters appear in the following order. Turn the JOG dial counterclockwise to go back to the previous character.

(space) A B C D E F G H I J K L M N O P Q R S T U
 V W X Y Z a b c d e f g h i j k l m n o p q r s t u v w
 x y z 0 1 2 3 4 5 6 7 8 9 ! " # \$ % & ' () * + , - . / : ; <
 = > ? @ [\] ^ _ ` { | } ~

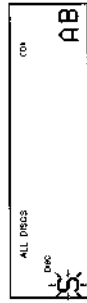

- 4** Push the JOG dial to select the character. The selected character lights up, and the flashing cursor appears to indicate the next space to be input.

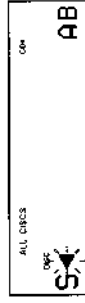

If you have made a mistake
 Press CLEAR and begin again by inputting the correct characters.

- 5** Repeat Steps 3 and 4 to input more characters.
6 Press INPUT to store the Disc Memo. The Disc Memo lights up in the display.

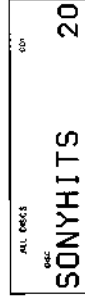

Repeat Steps 1 to 6 to assign Disc Memos to other discs.

Labeling discs using the remote

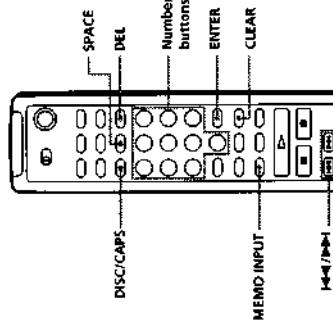

- 1** Press DISC/CAPS.
2 Press the number button of the disc you want to assign a Disc Memo, and then ENTER.
3 Press MEMO INPUT. The flashing cursor (◀) appears.
4 Press DISC/CAPS to find the letter type you want. Each time you press the button, the letter type changes cyclically among capital letters (AB), small letters (ab) and numbers (12). The selected letter type appears in the right end of the display.

(Continued)

- 5** Press the number button corresponding to the character you want (indicated beside each number button). The cursor disappears and the first space for the Disc Memo flashes. Each time you press the button, the character changes cyclically among the ones indicated beside the button.

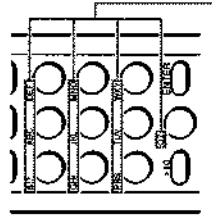

Characters assigned to each number button

Example: To select the letter E
 Press the number button 3 twice.

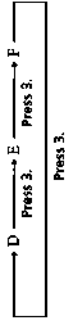

To insert a space, press SPACE once.
 To input a number, press DISC/CAPS twice in Step 4, then press the number button you want repeatedly until the symbol you want appears in the display.

- 6** Press ENTER to select the character. The selected character lights up, and the flashing cursor appears to indicate the next space to be input. You can also go to the next space by pressing other number buttons

- 7** Repeat Steps 4 through 6 to input more characters.
8 Press MEMO INPUT to store the Disc Memo. The Disc Memo lights up in the display.

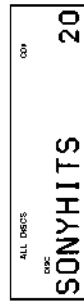

Repeat Steps 1 through 8 to assign Disc Memos to other discs.

- If you have made a mistake while inputting the character**
 To correct the character which has been input
1 Press ← or → until the cursor moves next to the incorrect character.



2 Press DEL to delete the incorrect character.



3 Input the correct character

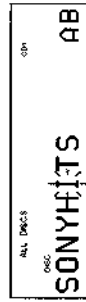

- To correct the character currently being input
1 Press DEL to delete the incorrect character.
2 Input the correct character.

To insert a character between the input characters
 Press ← or → until the cursor moves next to the point you want to insert, and enter the character.

Erasing the Disc Memo

- 1** Follow Steps 1 and 2 in "Labeling discs on the player" on page 22 to select the Disc Memo you want to erase.
2 Press CLEAR. The Disc Memo disappears.
3 Press INPUT.

Storing Specific Tracks (Delete Bank)

You can delete unwanted tracks and store only the tracks you want. When you select the disc containing a Delete Bank, you can play only the remaining tracks.

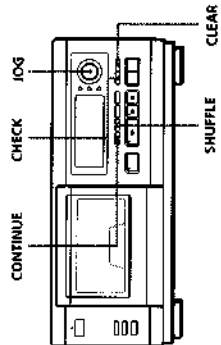

- 1 Press **CONTINUE** or **SHUFFLE** before you start playing.
- 2 Turn the **JOG** dial to select the disc.
- 3 Press **CHECK** repeatedly until the track you want to delete appears in the display.

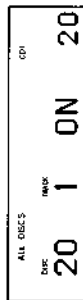

- 4 Press **CLEAR**. "DELETE FILE" and "OFF" appear in the display.

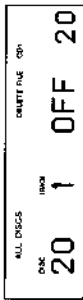

If you want to recover the track, press **CLEAR** again.

- 5 Repeat Steps 2 and 4 to delete more tracks.

You can recover all the tracks you have deleted

Hold down **CLEAR** until "ALL SELECT" appears in the display.

NOTE

The deleted tracks are skipped even in the Shuffle or Program Play mode (when the whole disc containing a Delete Bank is programmed as one step).

SECTION 3 DISASSEMBLY

Note : Follow the disassembly procedure in the numerical order given.

3-1. FRONT PANEL

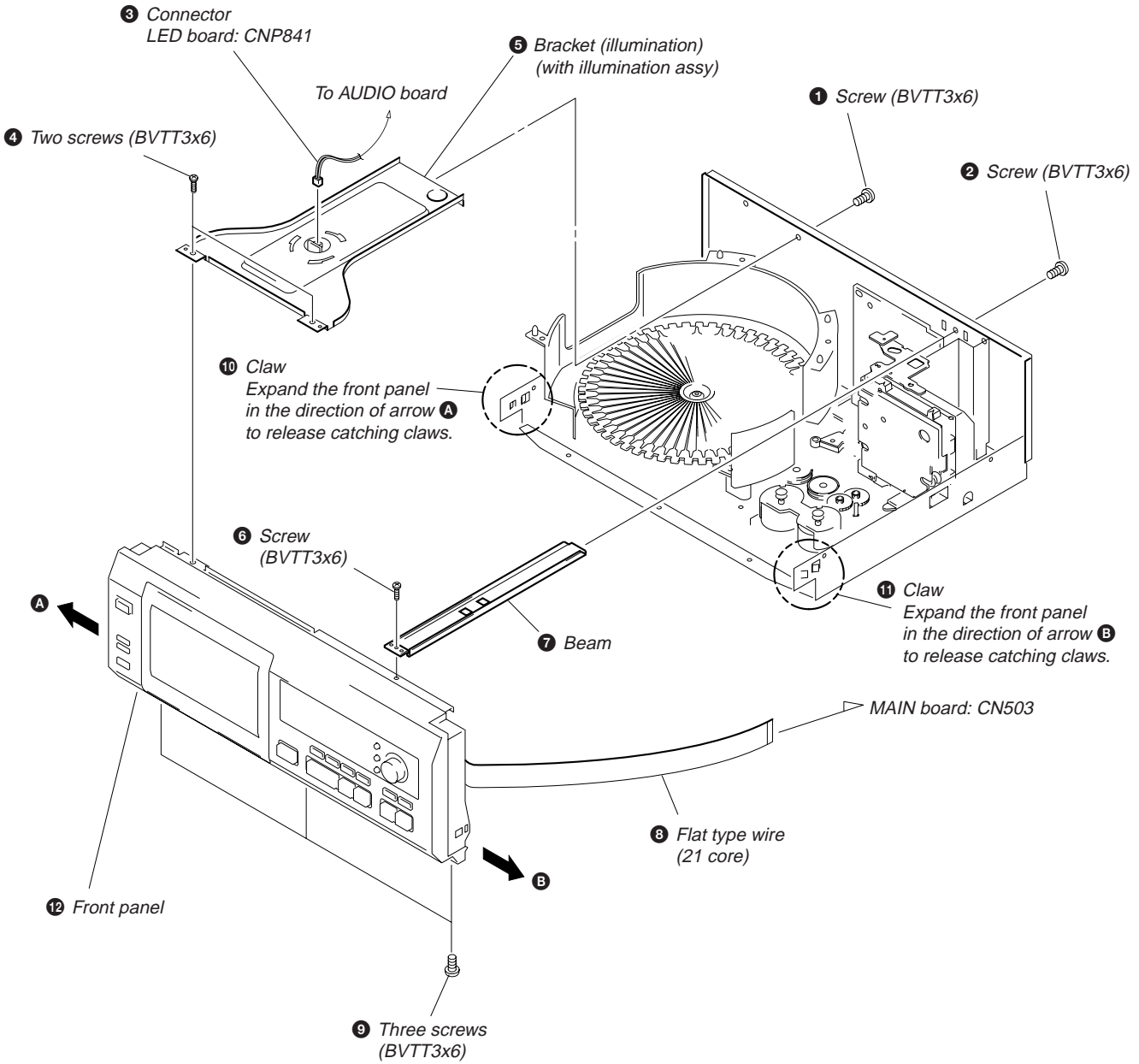

3-2. ILLUMINATION ASSY

While pressing arrows **A**, **B**, and **C**, rotate the illumination assembly in arrow direction **D** and remove it.

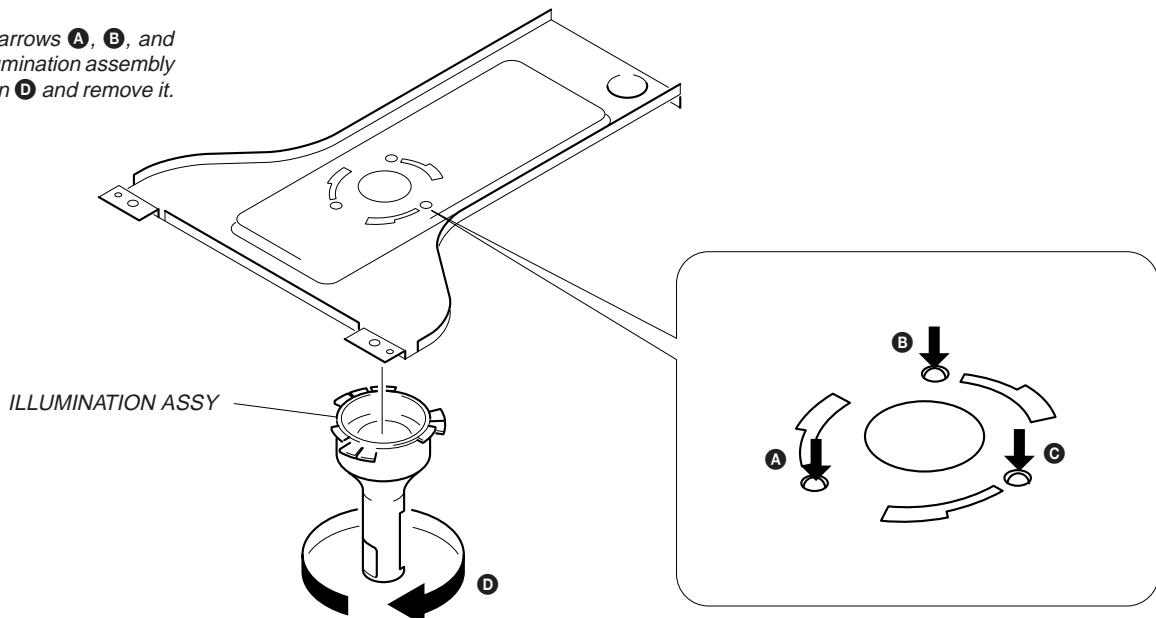

3-3. CD MECHANISM DECK

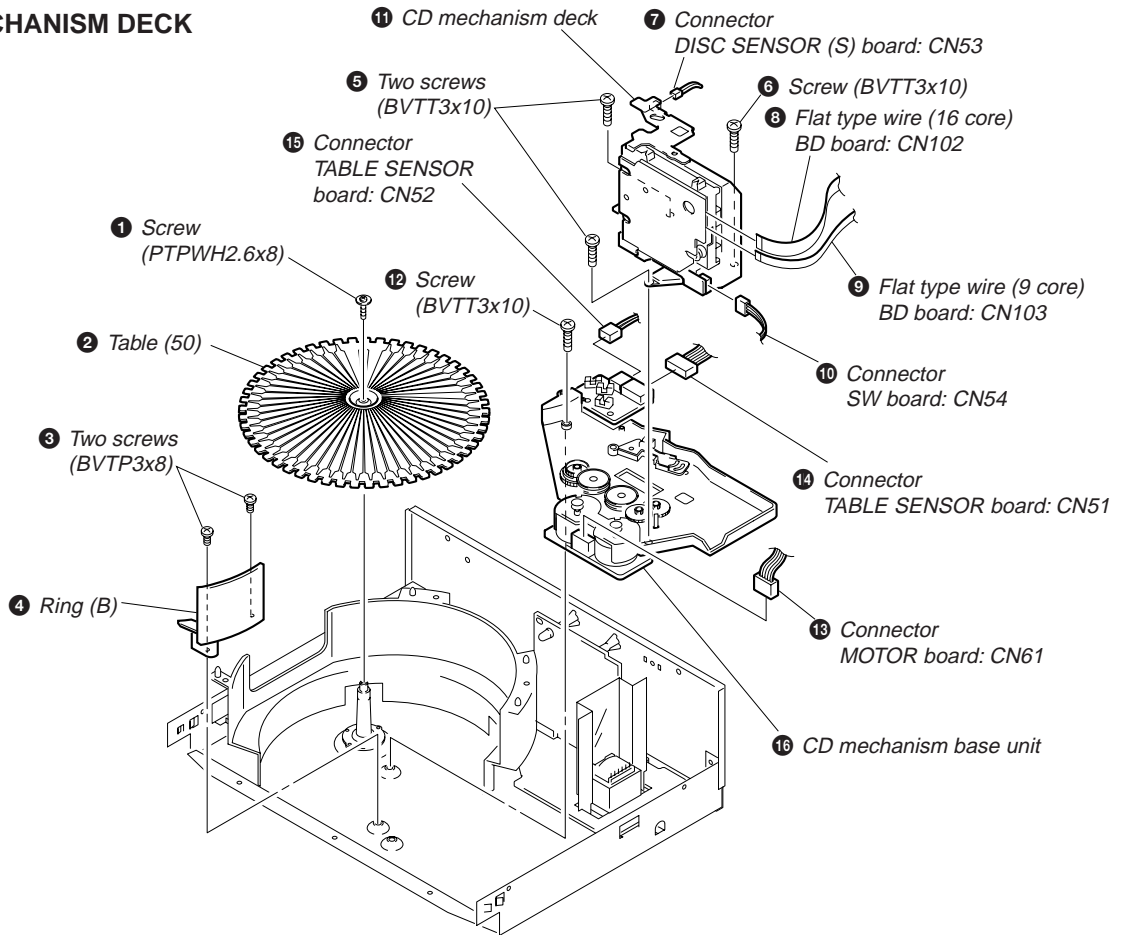

3-4. BASE UNIT AND MAGNET HOLDER

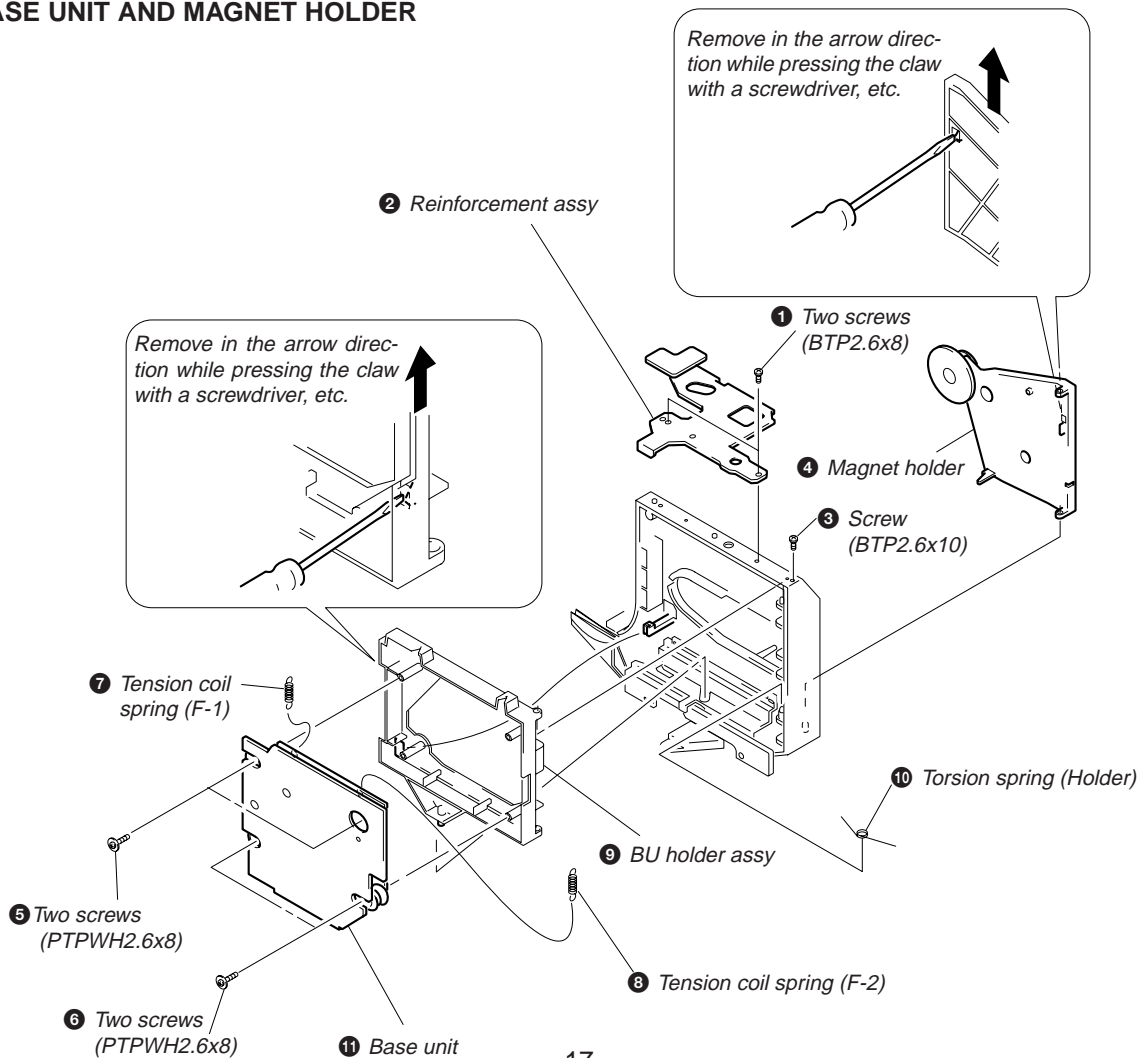

3-5. CD MECHANISM SECTION

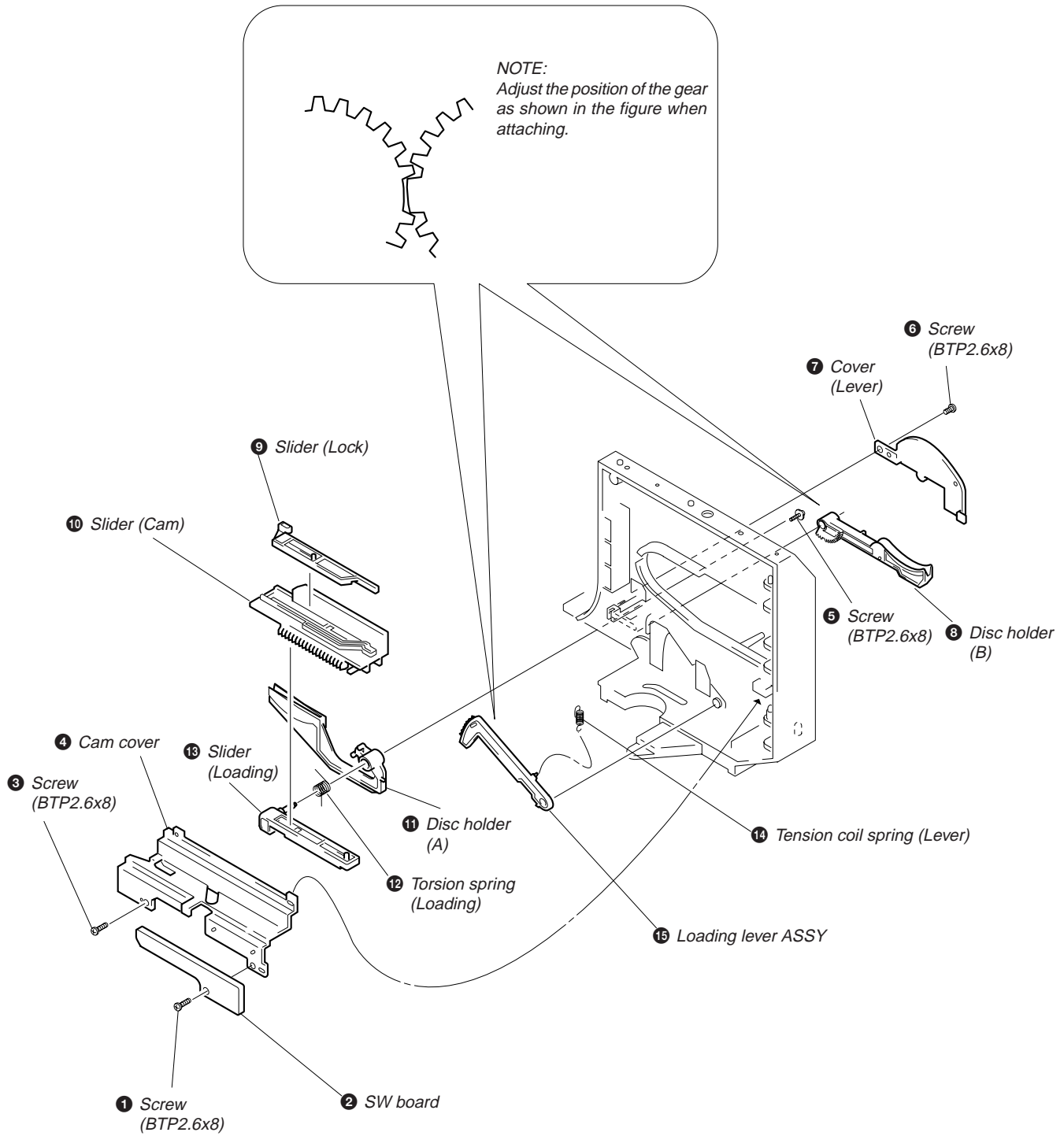

SECTION 4 TEST MODE

ADJ MODE

1. Press the POWER button to turn ON the power, and open the front cover.
2. Place the CD on the slit, close the front cover, and chuck the the CD.
3. Press the POWER button to turn OFF the power.
4. Short-circuit the test point (TP302:ADJ) and test point (TP303:GND) of the main board with a lead wire.
5. Press the POWER button to turn ON the power.
The CD is played back automatically and the ADJ mode is set.

- Prohibits high speed search during accessing
- Ignores even if GFS becomes L

ADJ Mode Special Function Table

(The buttons shown in the () function only when the remote commander provided is used.)

Button	Function
(3)	Tracking servo, sled servo OFF
(8)	Tracking servo, sled servo ON
CHECK	Observation mode during S
CLEAR	Automatic eccentricity measurement (Not used for servicing)

Display of special functions in ADJ mode

- Observation mode during S *1
When this mode is set, the right will be displayed. *1



- Automatic eccentricity measurement (Not used for servicing) *2
When this mode is set, the right will be displayed.
The Sokuteichu count down display will be counted down from 4 to to 1 *2.
After counting down, the eccentricity value will be displayed *3.



Sokuteichu count down display



Eccentricity value

FLUORESCENT INDICATOR TUBE, LED ALL LIT, AND KEY CHECK MODE

1. Short-circuit the test point (TP302:ADJ) and test point (TP301:AFADJ) of the main board with a lead wire.
2. Insert the power plug into the outlet. The whole fluorescent indicator tube lights up.
When the SRAM is faulty, "SRAMNG" will be displayed.
3. When the front cover is opened, the POWER button LED goes off. Closing the front cover will light it up again.
Pressing the POWER button sets the key check mode.
The POWER button LED also lights up.
All buttons have individual button numbers.
When a button is pressed, the button number is counted up and displayed.

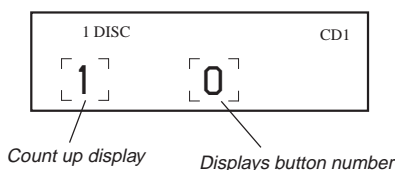

Buttons and Corresponding Button Numbers

Button	Button Number or Display
CLEAR	0
CHECK	1
REPEAT	2
PROGRAM	3
SEARCH	4
INPUT	5
TIME/TEXT	6
ENTER	7
▷▷	8
◁◁	9
CONTINUE	14
SHUFFLE	15
POWER	16
X-FADE	17
NO DELAY	18
▷	All lit (LED lights up)
▬▬	Partially lit 1 (LED lights up)
■	Partially lit 2
PLUS ONE	LED lights up
MEGA CONTROL	Partially lit 3 (LED lights up)
DISC/CHARACTER	Partially lit 4 Each time JOG is rotated, PROGRAM 123 is displayed on the fluorescent indicator tube, and 1, 2, 3 light up one by one. Clockwise : PROGRAM 1→2→3 Counterclockwise : PROGRAM 3→2→1

Partially lit 1



Partially lit 2

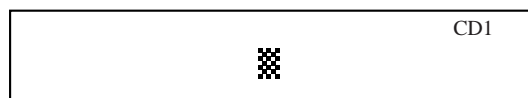

Partially lit 3



Partially lit 4



FLUORESCENT INDICATOR TUBE AND LED CHECK MODE

This mode is set by pressing the POWER button while pressing the CHECK and PLUS ONE buttons in the power-off (standby) state.

The whole fluorescent indicator tube lights up, and the STANDBY, MEGA CONTROL, PLUS ONE, \triangleright , and \blacksquare LEDs light up. This mode can be exited by pressing the POWER button.

SHIPMENT MODE

(Set to this mode when returning the unit to the user.)

This mode is set by pressing the POWER button while pressing the REPEAT and PLUS ONE buttons in the power-off (standby) state.

The power goes off automatically after the SRAM is all-erased and the BD is opened (loading out state).

[MAIN BOARD] — CONDUCTOR SIDE —

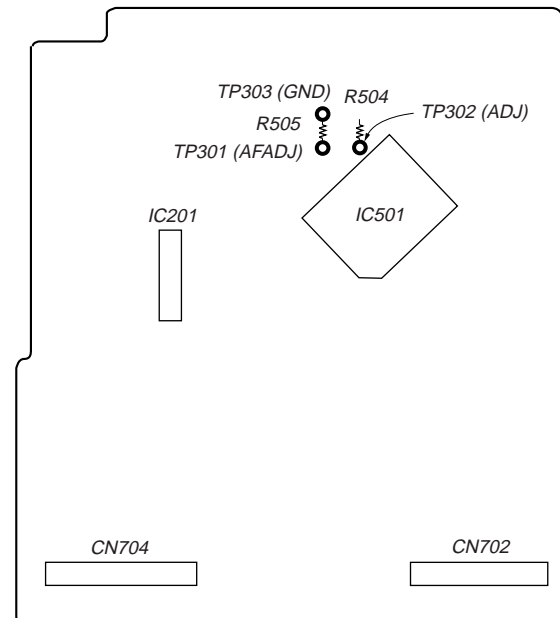

AGING MODE

- Mode which repeatedly changes and plays back discs automatically in the unit.
 - It will repeat aging as long as no errors occur.
 - If an error occurs during aging, it will stop all servos, motors, etc. instantaneously, display the error number, and stop operations. However, the stopping conditions differ according to whether the unit is equipped with the "self-protection function during errors" described later.
- The function serves to maintain the state of the unit when errors occur.

Sequence of Aging Mode

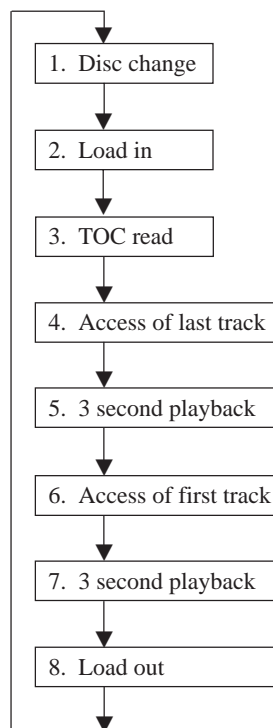

Order of Disc Change

(1 cycle takes 3 minutes)

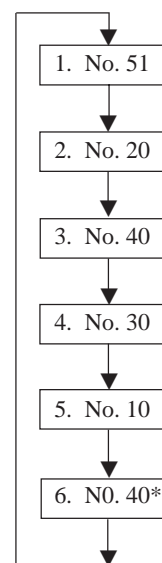

* DISC No. 40 chucks twice during one cycle.

To differentiate, the "2nd" on the block indicator of the fluorescent indicator tube will light up during the second chucking.

Special Functions in Aging Mode

There are some useful function in the aging mode.

- Disc setting mode*1
- Switching of use/disuse of protection function in errors *2
- Aging cycle count function *3

*1 Disc setting mode:

5 discs are set before setting the aging mode. This mode makes the setting of these discs more easy.

*2 Switching of use/disuse of protection function in errors:

Function which voluntarily corrects errors which occur during normal operations by retries.

If this function is not provided, all operations will be stopped without retiring. It is suitable for checking errors with low reproducibility.

If this function is provided, and errors can be corrected by retries, aging will be continued without stopping.

(The normal aging should be performed with "be".)

***3 Aging cycle count function:**

Functions which displays the number of agings carried out on the Fluorescent indicator tube in numbers. One aging cycle consists of six discs.

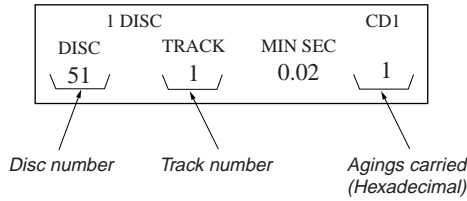

Aging procedure:

Some operating method will be changed depending on if the following jig for the aging mode exists or not.

- Jig

Parts. No	Description
J-2501-123-A	Remote commander (For aging mode)

With remote commander for aging mode:

1. Turn ON the power of the unit. Open the front cover.
2. Press the [AGING START] button of the remote commander for aging mode.
3. When the disc set mode is set, the [▶] and [■] LEDs blink.
4. Rotate the JOG dial. The slits (No. 10, 20, 30, 40, 51) for setting the discs will come forward. Insert the discs into these slits. Do not set the discs in other slits.
5. Set the use/disuse of the self protection function in errors. Press the [REPEAT] button. When REPEAT is displayed on the fluorescent indicator tube, the self protection function during the error will become "Use".
If the REPEAT display is OFF, it means that the function is not used. (Normally set to "Use" when performing aging.)
7. Press the [▶] button.
8. The [▶] LED blinks, the aging mode is set, and aging is started.
9. The aging cycle lasts 3 minutes. When problems occur during aging, the error number will be displayed on the fluorescent indicator tube, and the [■] LED will light up.
(Refer to the following table for the details of the errors.)
10. Aging will be repeated as long as no errors occur.
11. After each aging cycle, the number displayed on the Fluorescent indicator tube will increase.
12. To end aging, press the [POWER] button

Error Display

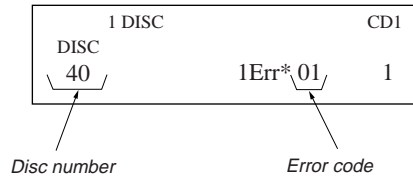

Without remote commander for aging mode:

1. Turn ON the power of the unit. Open the front cover.
2. Press the [CONTINUE], [◀], and [▶] buttons in order.
3. When the disc set mode is set, the [▶] and [■] LEDs blink.

The following procedure is the same as in the case "With remote commander for aging mode".

Error code

Code number	Name	Contents
Err 01	DISC sensor check 1	No disc in the specified slit
Err 02	DISC sensor check 2	Disc in other slits
Err 03	_____	No function
Err 04	Table operation check 2	No table sensor input
Err 05	Loading operation check 1	Load in timeover
Err 06	Loading operation check 2	Load out timeover
Err *1	BU related check 1	Access timeover
Err *2	BU related check 2	High speed search NG
Err *3	BU related check 3	Q data read error
Err *4	BU related check 4	BU operation (From focus search to until signal can be read) timeover
Err *5	BU related check 5	GFS monitor error
Err *6	BU related check 6	Focus cannot be imposed by focus search

The * numbers mean the following according to the state of the unit during aging

- 2 : From chucking to end of TOC read
- 3 : From end of TOC read to end of last track playback
- 4 : From end of last track playback to end of first track playback

SECTION 5 MECHANICAL ADJUSTMENTS

To adjust the mechanism section, enter the mechanism section adjustment mode.
For how to enter the mechanism section adjustment mode, refer to each adjustment section.

DISC SENSOR ALIGNMENT

1. Make sure that there is no disc in the unit.
2. Connect an oscilloscope to TP501 of the AUDIO board.

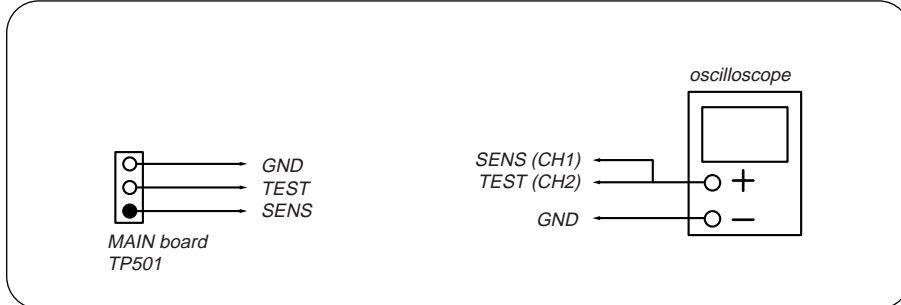

3. While pressing the **CLEAR** and **PLUS ONE** buttons at the same time and turn ON the power.

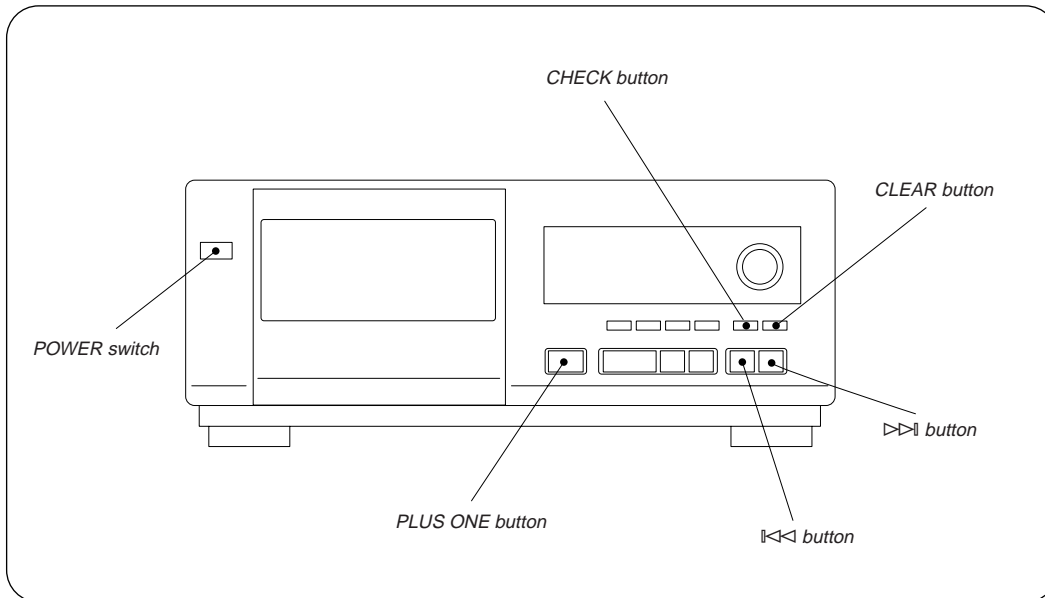

4. The fluorescent indicator tube shows as follows, and the mechanism section adjustment mode is set.

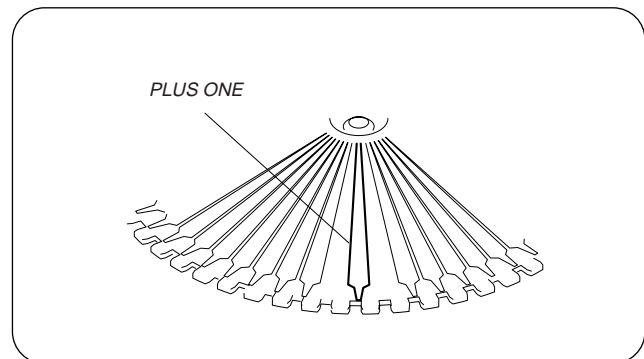
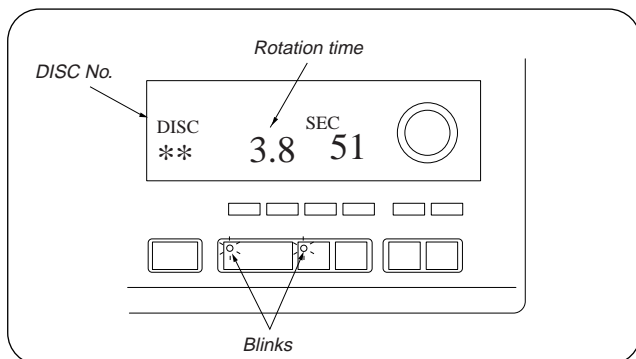

5. The disc table rotates in the clockwise direction. The disc table rotation time is displayed with "PLUS ONE" slit as a measuring point.
6. Press the **CLEAR** button, to be rotated the disc table counterclockwise.
7. Measure the waveform of the oscilloscope when the disc table is rotating.

8. Move the holder (sensor) center so that the flat portion center at the top of the SENS (CH1) input waveform and the "H" center of TEST (CH2) coincide.

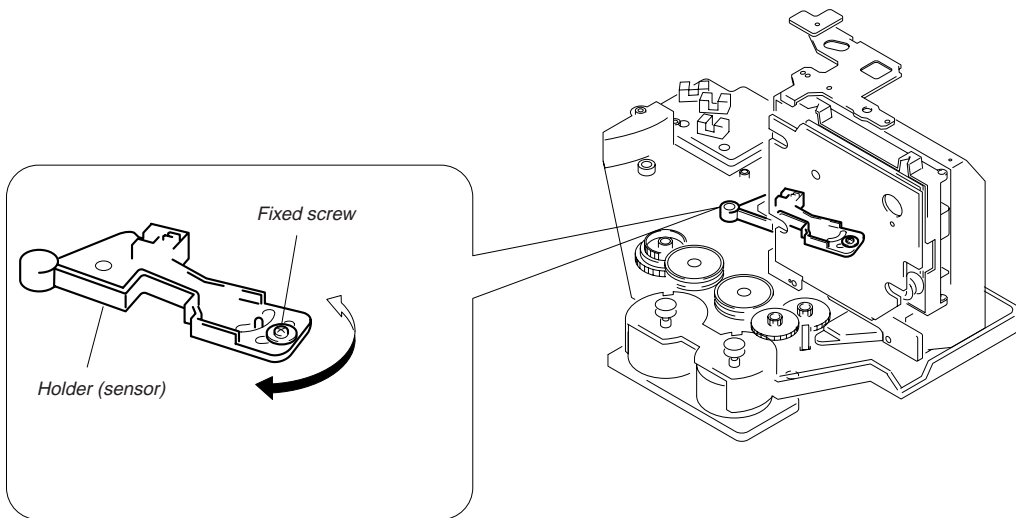
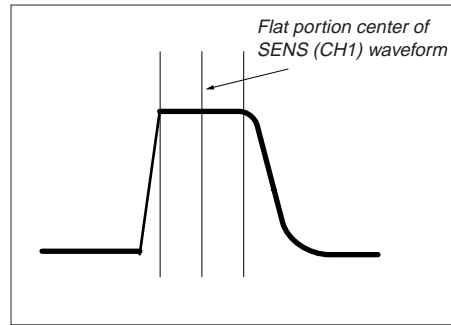
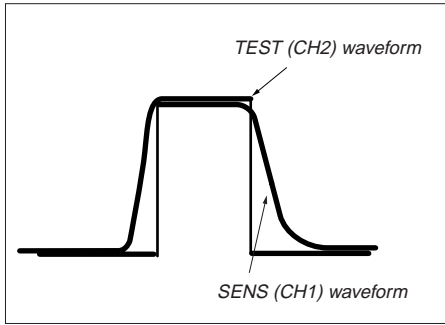

9. Tighten the fixed screw to fix the disc table, then press the **CLEAR** button.
10. The disc table rotates in the clockwise direction. Measure the waveform and make sure that the flat portion center at the top of the SENS (CH1) input waveform and the "H" center of TEST (CH2) conform.
- Note:** During the adjustment mode, the rotational direction is switched each time the **CLEAR** button is pressed. Pressing the **CHECK** button enters the loading mode which will be described later. Pressing the **CLEAR** button rotates the disc table again.

Contents of the fluorescent indicator tube's display in the loading mode

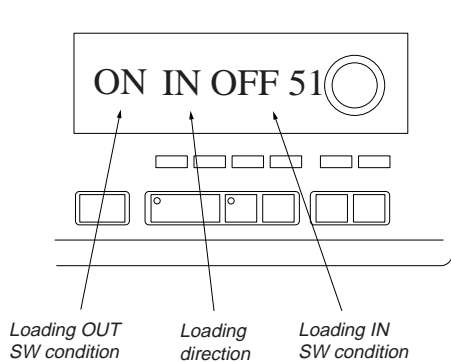

MAGNET ASSY ALIGNMENT

1. Check that there is no disc in the unit and then turn ON the power. Open the door, and set a disc in the PLUS ONE slit.
2. Turn OFF the power, close the door, and while pressing the **CLEAR** and **PLUS ONE** buttons simultaneously, turn ON the power again.
3. Press the **CHECK** button, and set the loading mode.
4. Press the **▶▶□□** button and chuck the disc.
5. Adjust the magnet assembly and magnet holder so that $A=B$ as shown in the figure.

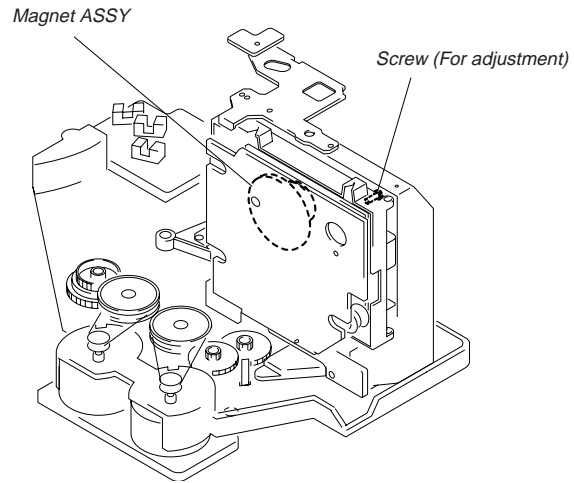
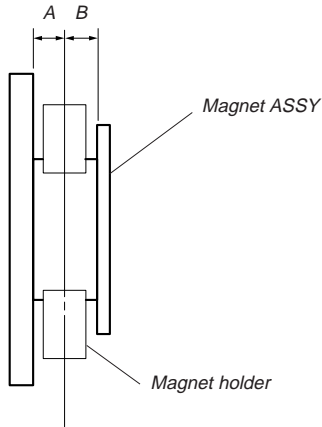

DISC HOLDER A ALIGNMENT

1. Check that there is no disc in the unit and then turn ON the power. Open the door, and set a disc in the PLUS ONE slit.
2. Turn OFF the power, close the door, and while pressing the **CLEAR** and **PLUS ONE** buttons simultaneously, turn ON the power again.
3. Press the **CHECK** button, and set the loading mode.
4. Press the **▶▶□□** button and chuck the disc.
5. Press **▶▶□□** or **□□◀◀** button to stop the disc holder A slightly away from the disc.
6. Rotate and adjust the adjusting screw so that the center of the disc and that of the disc holder coincide.

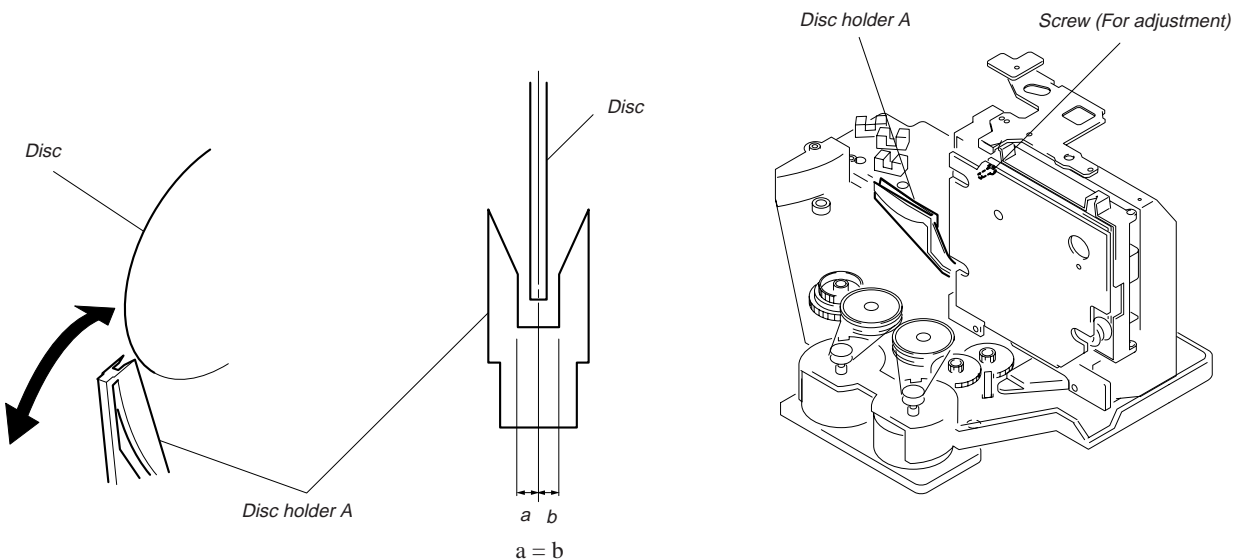

SECTION 6 ELECTRICAL ADJUSTMENTS

Note :

1. CD Block is basically designed to operate without adjustment. Therefore, check each item in order given.
2. Use YEDS-18 disc (3-702-101-01) unless otherwise indicated.
3. Use an oscilloscope with more than 10MΩ impedance.
4. Clean the object lens by an applicator with neutral detergent when the signal level is low than specified value with the following checks.

S Curve Check

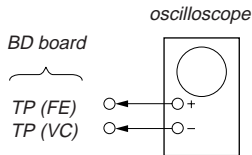

Procedure :

1. Press the **POWER** button and turn ON the power supply.
2. Open the front cover, and press the **PLUS ONE** button.
3. Set the disc (YEDS-18) into the "PLUS ONE" slit.
4. Close the front cover, and chuck the disc.
5. Press the **POWER** button and turn OFF the power.
6. Connect the oscilloscope to TP (FE) of the BD board.
7. Connect TP302 (ADJ) of the MAIN board and connect TP303 (GND) with a lead wire.
8. Press the **POWER** button and turn ON the power.
9. The first track will be played back automatically. When the **CHECK** button is pressed, "S-JI mode" will be displayed on the fluorescent indicator tube, and focus search will be repeated.
10. Check the oscilloscope waveform (S-curve) is symmetrical between A and B. And confirm peak to peak level within 1.8 ± 0.6 Vp-p.

S-curve waveform

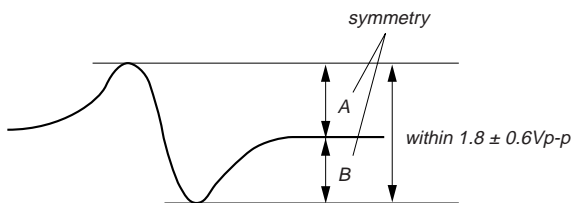

11. Turn OFF the power, and remove the lead wire connected at step 7.

Note :

- Try to measure several times to make sure than the ratio of A : B or B : A is more than 10 : 7.
- Take sweep time as long as possible and light up the brightness to obtain best waveform.

RF Level Check

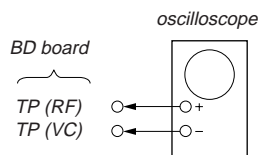

Procedure :

1. Press the **POWER** button and turn ON the power supply.
2. Open the front cover, and press the **PLUS ONE** button.
3. Set the disc (YEDS-18) into the "PLUS ONE" slit.
4. Close the front cover, and chuck the disc.
5. Press the **POWER** button and turn OFF the power.
6. Connect the oscilloscope to TP (RF) of the BD board.
7. Connect TP302 (ADJ) of the MAIN board and connect TP303 (GND) with a lead wire.
8. Press the **POWER** button and turn ON the power.
9. Playback the fifth track of the disc.

10. Confirm that oscilloscope waveform is clear and check RF signal level is correct or not.
11. Turn OFF the power, and remove the lead wire connected at step 7.

Note : A clear RF signal waveform means that the shape "◇" can be clearly distinguished at the center of the waveform.

RF signal waveform

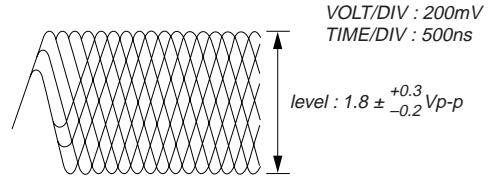

E-F Balance (Traverse) Check

The procedure for this checking method differs for when a general remote control unit is used and not used.

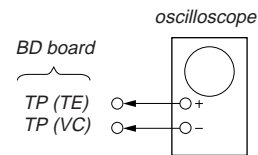

When a general remote commander is used:

1. Press the **POWER** button and turn ON the power supply.
2. Open the front cover, and press the **PLUS ONE** button.
3. Set the disc (YEDS-18) into the "PLUS ONE" slit.
4. Close the front cover, and chuck the disc.
5. Press the **POWER** button and turn OFF the power.
6. Connect the oscilloscope to TP (TE) of the BD board.
7. Connect TP302 (ADJ) of the MAIN board and connect TP303 (GND) with a lead wire.
8. Press the **POWER** button and turn ON the power.
9. Playback the fifth track of the disc.
10. Press the **3** button on the remote commander. (The tracking servo and the sledding servo are turned OFF.)
11. Check the level B of the oscilloscope's waveform and the A (DC voltage) of the center of the Traverse waveform. Confirm the following :
 $A/B \times 100 = \text{less than } \pm 10\%$

Traverse waveform

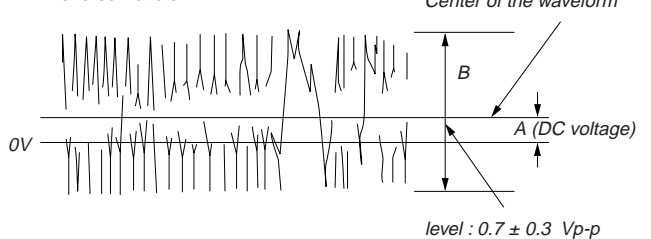

12. Press the **8** button on the remote control unit. (The tracking servo and sledding servo are turned ON.) Confirm the C (DC voltage) is almost equal to the A (DC voltage) is step 11.

Traverse waveform

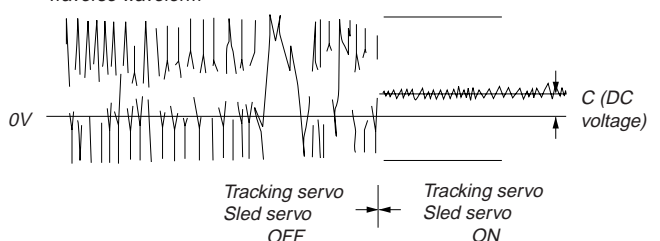

13. Turn OFF the power, and remove the lead wire connected at step 7.

When a general remote commander is not used:

1. Solder lead wires to TP (DVDD) and TP (TOFF) on the BD board severally.
2. Connect the oscilloscope to TP (TE) of the BD board.
3. Press the **POWER** button and turn ON the power supply.
4. Open the front cover, and press the **PLUS ONE** button.
5. Set the disc (YEDS-18) into the "PLUS ONE" slit.
6. Close the front cover, and chuck the disc.
7. Playback the fifth track of the disc.
8. Short-circuit the lead wire connected at step 1. (The tracking servo is turned OFF)
9. Check the level B of the oscilloscope's waveform and the A (DC voltage) of the center of the Traverse waveform.
Confirm the following :
 $A/B \times 100 = \text{less than } \pm 10\%$

Traverse waveform

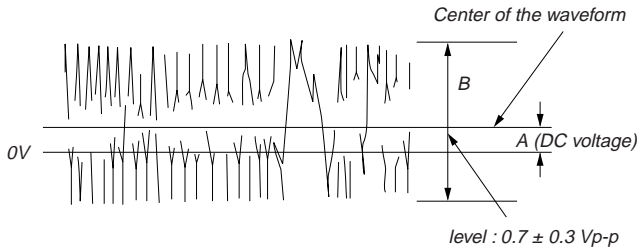

10. Disconnect the lead wire short-circuited at step 8. (The tracking servo is turned ON.) Confirm the C (DC voltage) is almost equal to the A (DC voltage) is step 8.

Traverse waveform

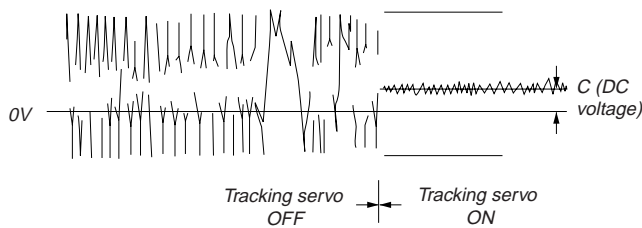

11. Turn OFF the power, and remove the lead wire connected at step 1.

RF PLL Free-run Frequency Check

Procedure :

1. Connect the frequency counter to TP (PLCK) of the BD board.

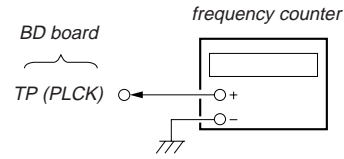

2. Press the **POWER** button and turn ON the power supply.
3. Open the front cover, and press the **PLUS ONE** button.
4. Set the disc (YEDS-18) into the "PLUS ONE" slit.
5. Close the front cover, and chuck the disc.
6. Playback the fifth track of the disc.
7. Confirm that reading on frequency counter is $4.3218 \text{ MHz} \pm 30 \text{ kHz}$.

About RV601 on the MAIN board

RV601 of the MAIN board requires no adjustments. Please note that it should be dixed to mechanical center position when you moved and do not know origin position.

Adjustment Location :

[BD BOARD] — CONDUCTOR SIDE —

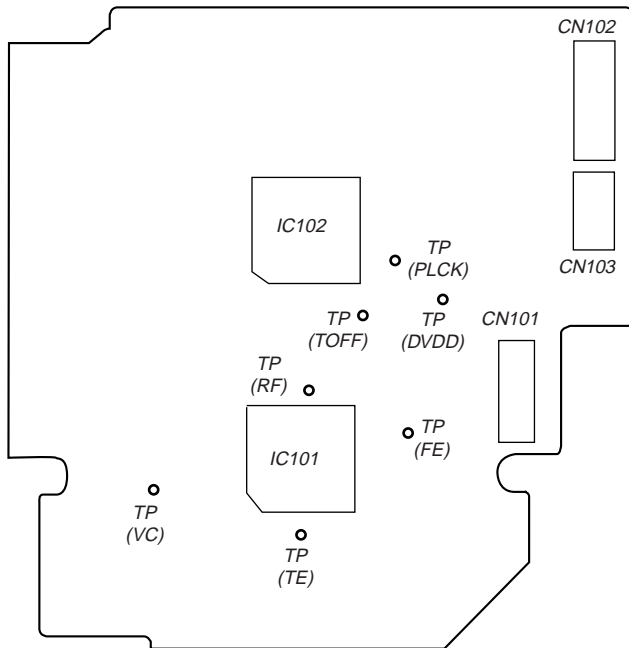

[MAIN BOARD] — CONDUCTOR SIDE —

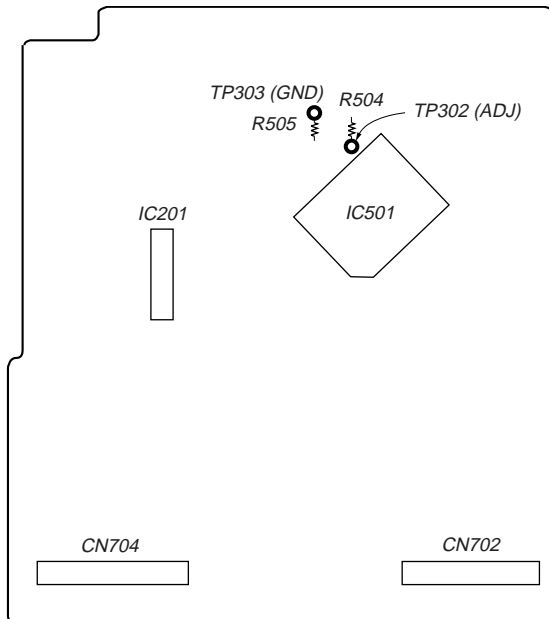

[MAIN BOARD] — COMPONENT SIDE —

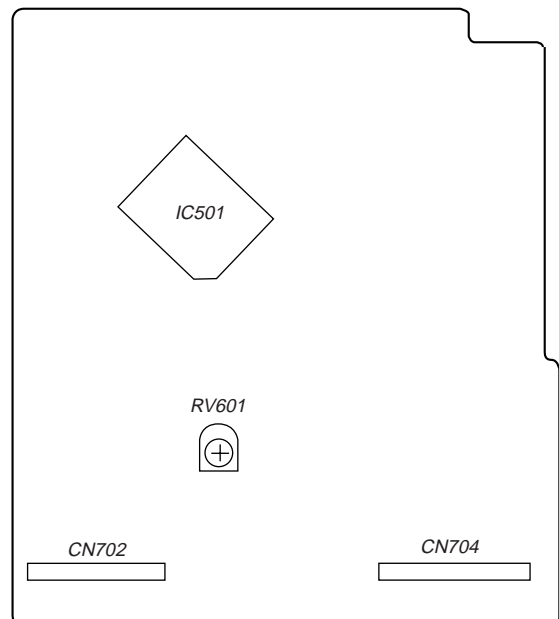

SECTION 7 DIAGRAMS

7-1. CIRCUIT BOARDS LOCATION

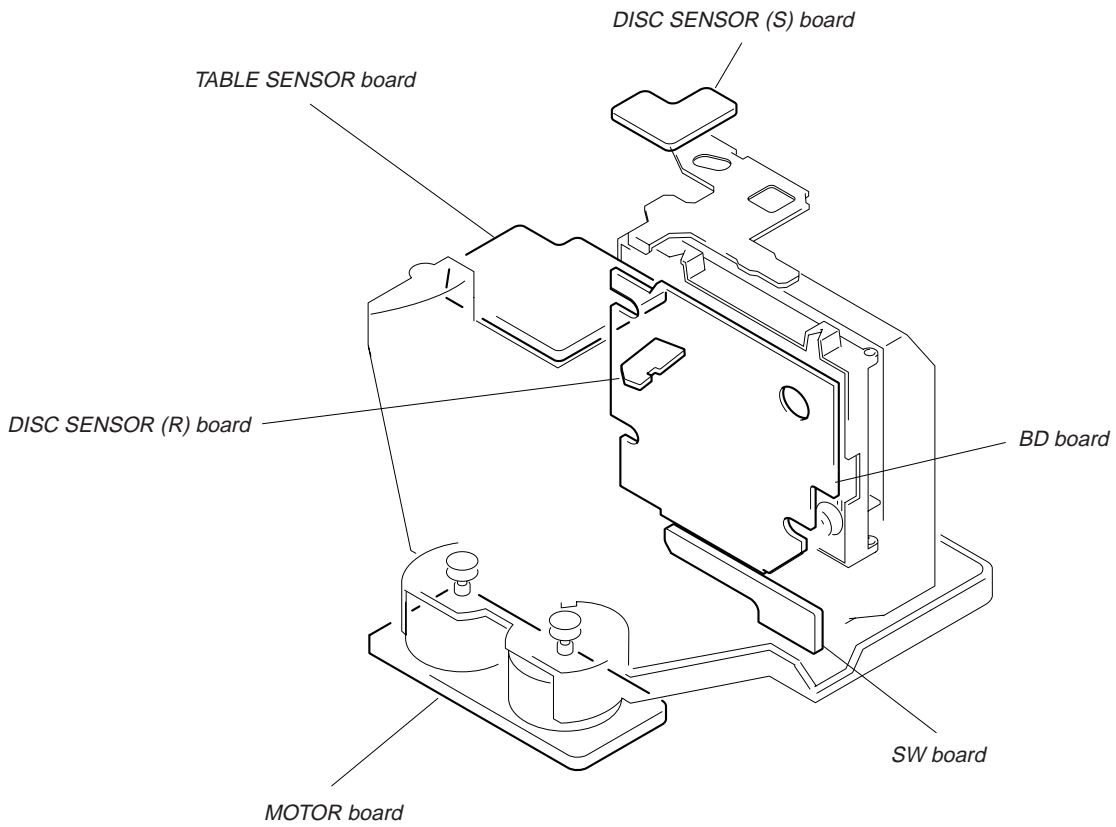
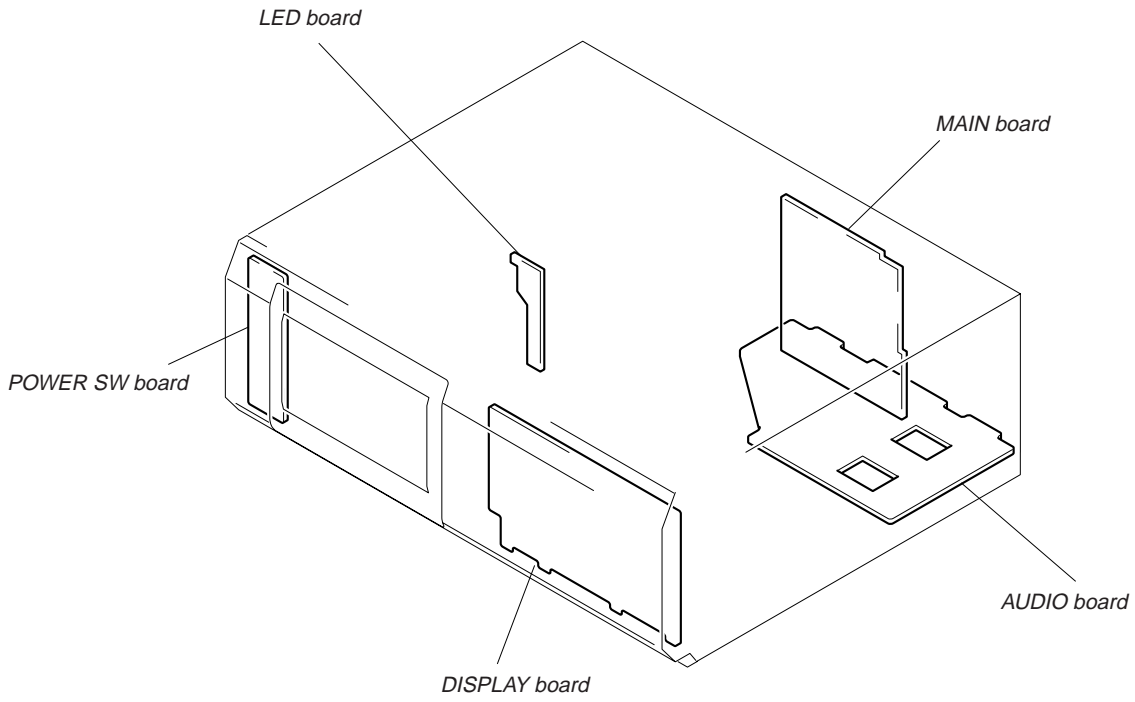

THIS NOTE IS COMMON FOR PRINTED WIRING BOARDS AND SCHEMATIC DIAGRAMS.
(In addition to this, the necessary note is printed in each block.)

NOTE

- — : parts extracted from the component side.
- : parts extracted from the conductor side.
- ▒ : Pattern from the side which enable seeing.
- : parts mounted on the conductor side.
- ▨ : Solder bridge

NOTE

- All capacitors are in μF unless otherwise noted. pF : $\mu\mu\text{F}$ 50WV or less are not indicated except for electrolytics and tantalums.
- All resistors are in Ω and 1/4W or less unless otherwise specified.
- : panel designation.

Note:

The components identified by mark \triangle or dotted line with mark \triangle are critical for safety. Replace only with part number specified.

Note:

Les composants identifiés par une marque \triangle sont critiques pour la sécurité. Ne les remplacer que par une pièce portant le numéro spécifié.

- **B+** : B+ Line
- **B-** : B- Line
- Voltage and waveforms are dc with respect to ground under no-signal conditions.
no mark : STOP
- Voltages are taken with a VOM (Input impedance 10M Ω).
Voltage variations may be noted due to normal production tolerances.
- Waveforms are taken with a oscilloscope.
Voltage variations may be noted due to normal production tolerances.
- Circled numbers refer to waveforms.
- Signal path.
- ▨ : CD
- ▨ : CD (digital)
- Abbreviation
- CND : Canadian model.
- SP : Singapore model.
- AUS : Australian model.

• Waveforms

BD SECTION

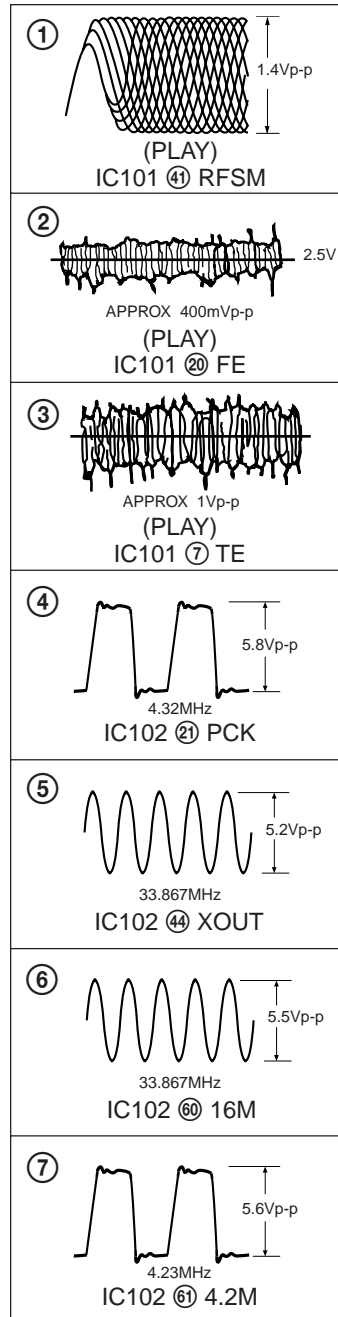

MAIN SECTION

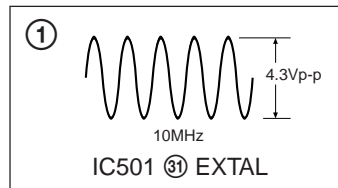

7-2. IC BLOCK DIAGRAMS

IC101 LA9240M

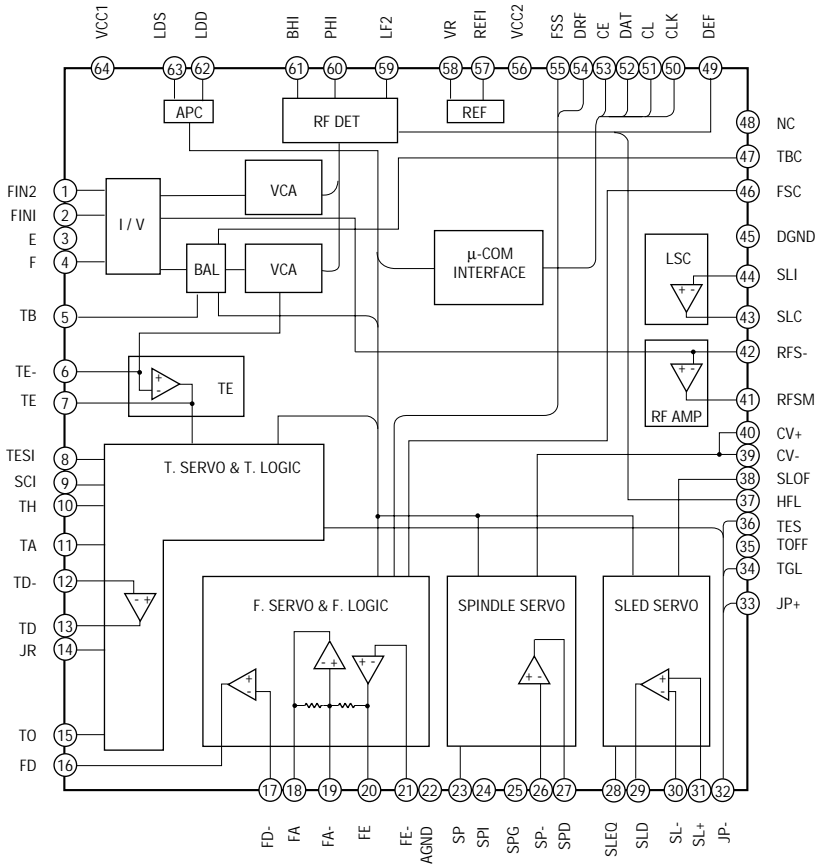

IC102 LC78622E

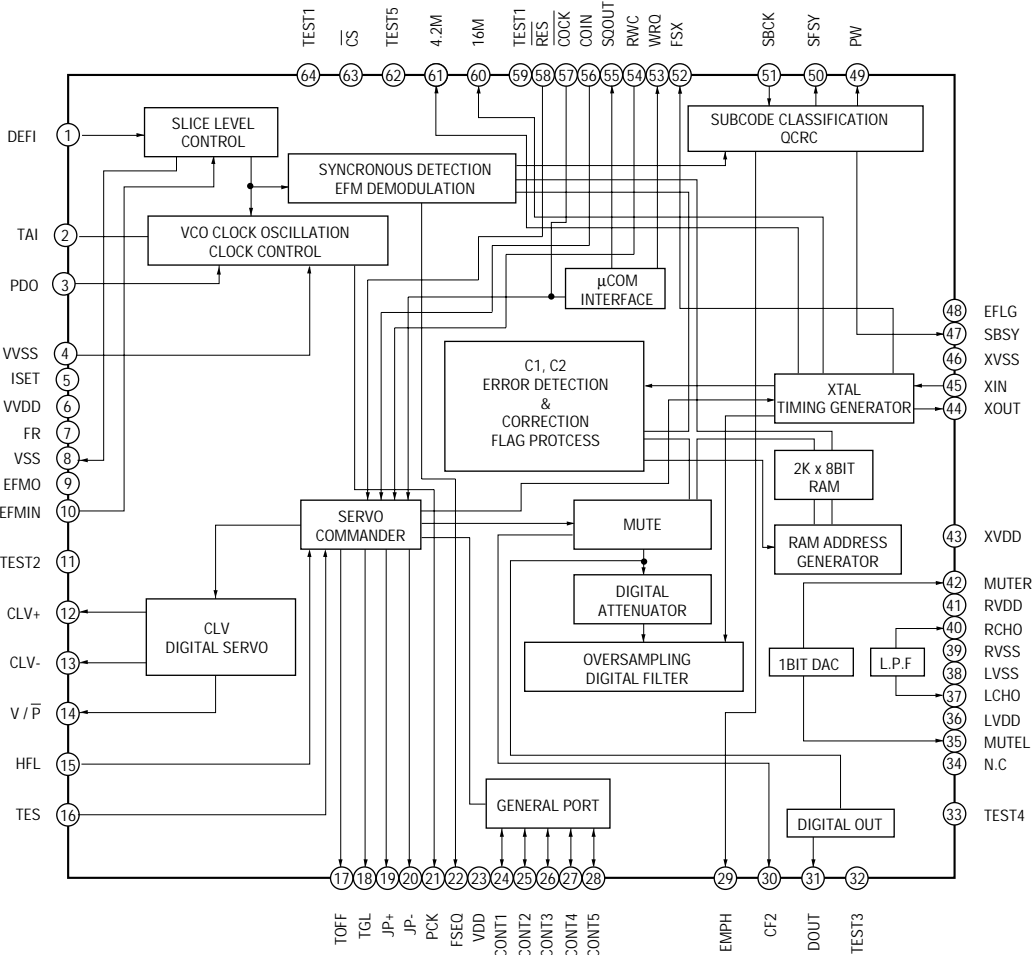

IC103 LA6541

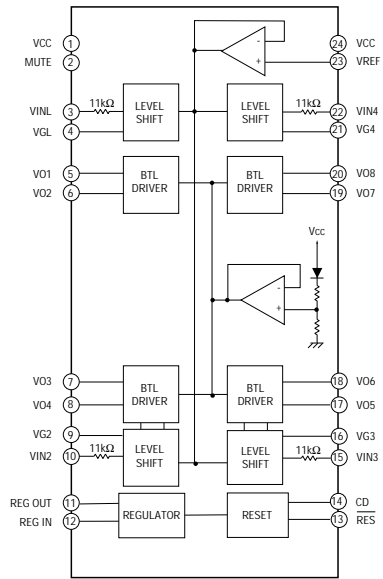

IC201 LA5602

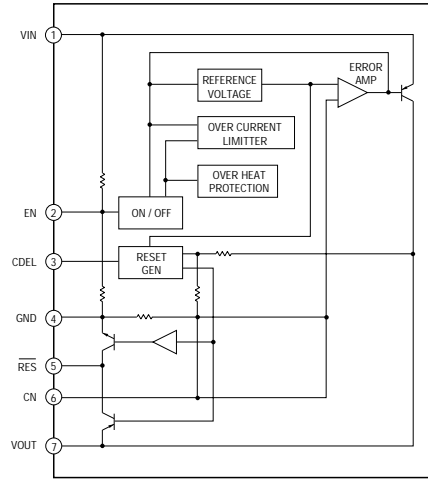

IC601 BA6780

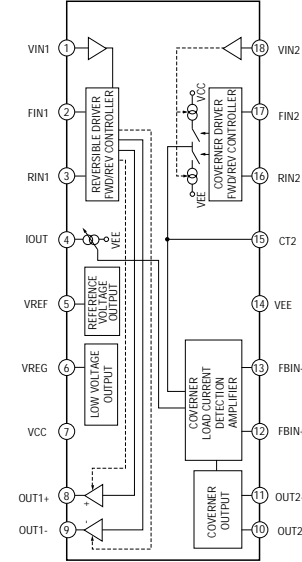

IC104 LC89170M

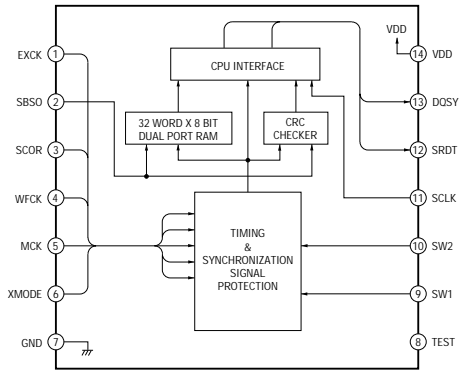

IC203 LA5601

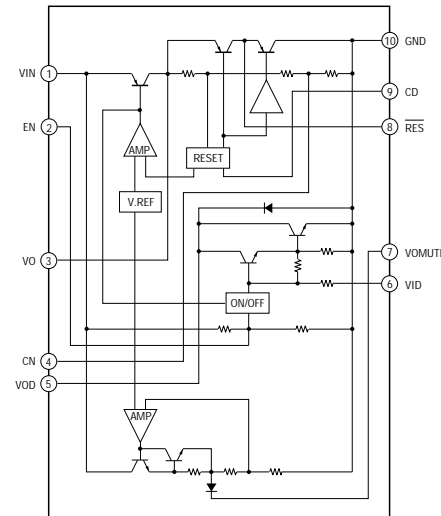

7-3. BLOCK DIAGRAMS
— BD SECTION —

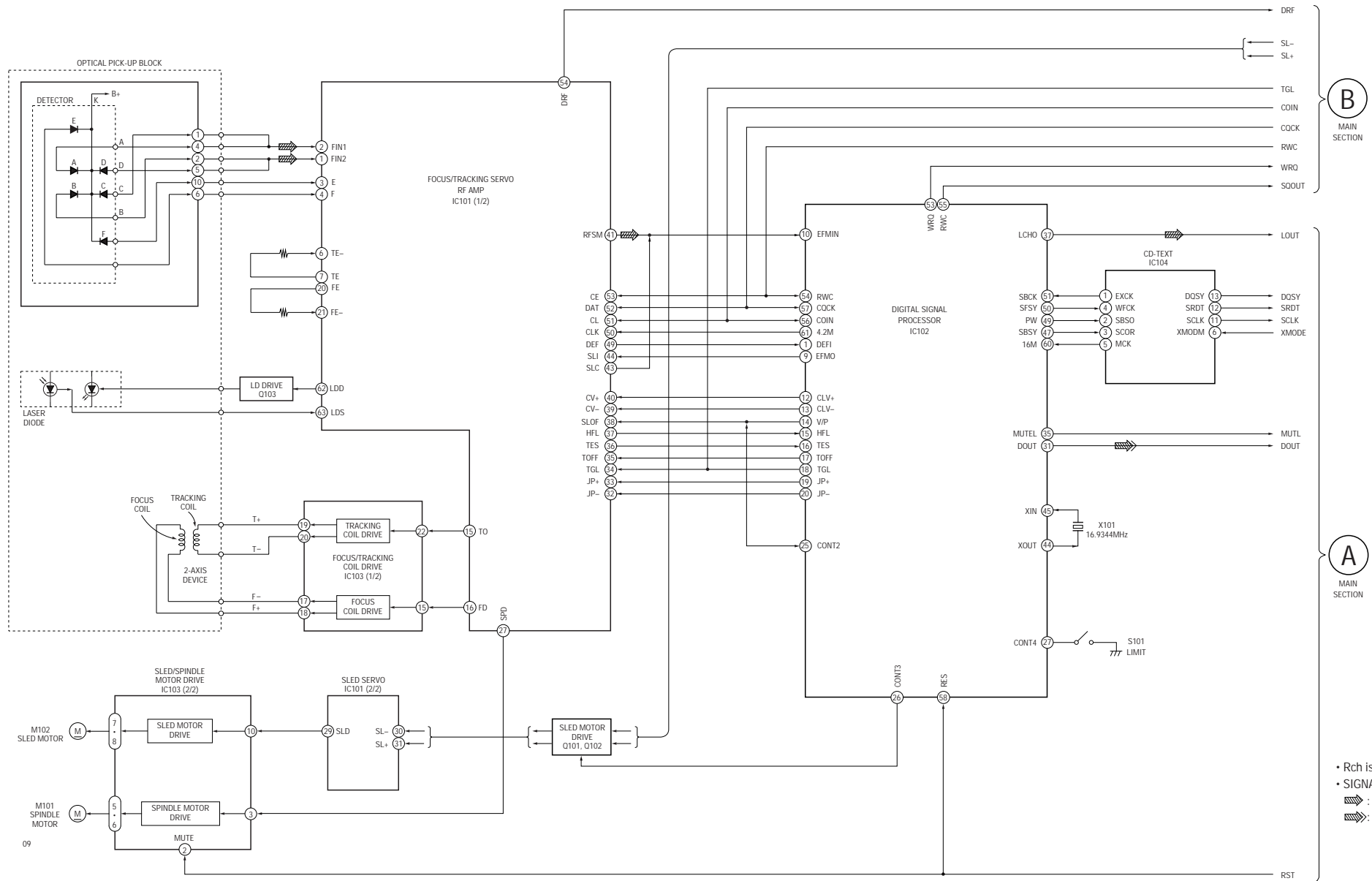

— MAIN SECTION —

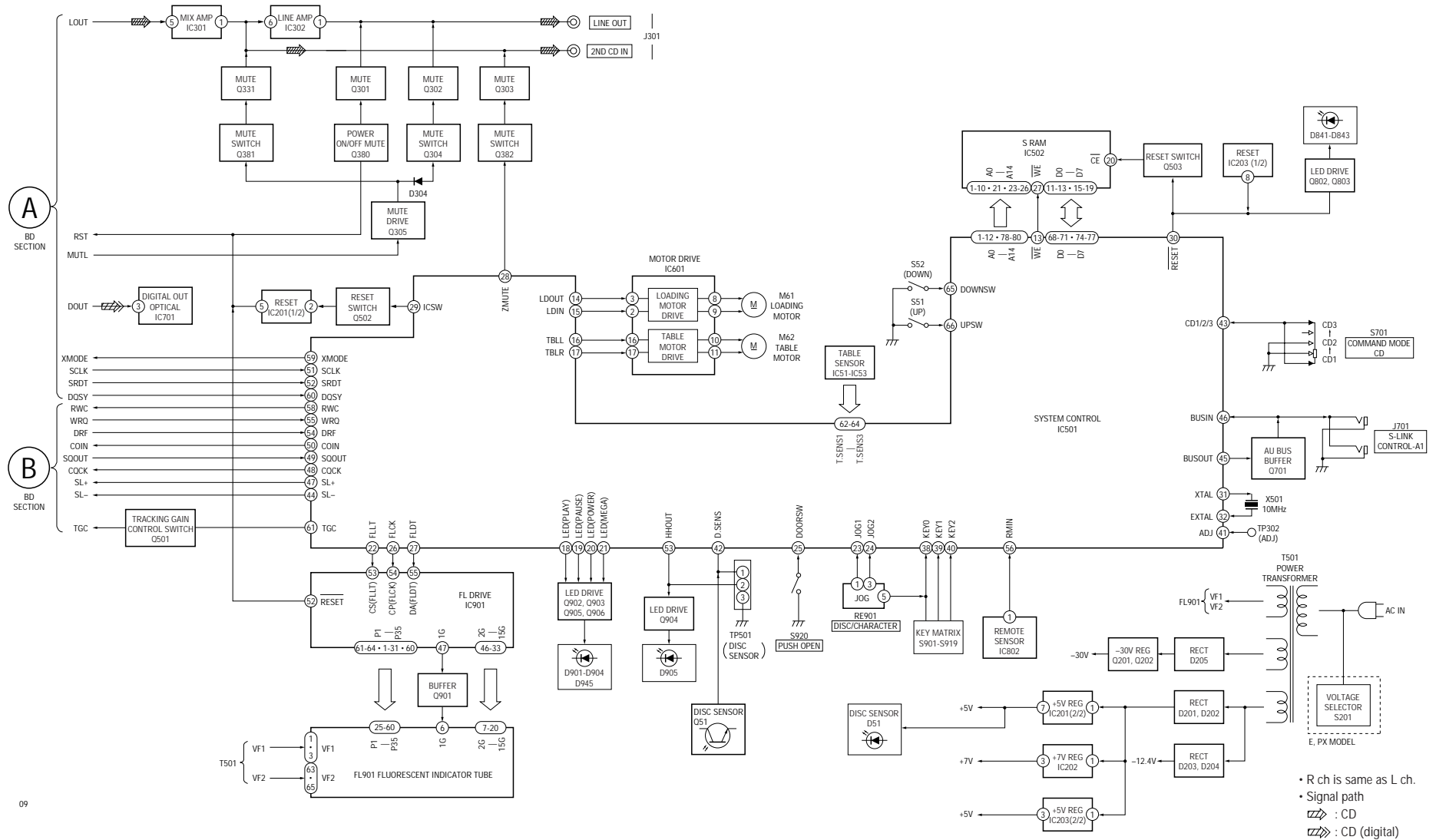

7-4. PRINTED WIRING BOARD — BD SECTION —

• See page 28 for Circuit Boards Location.

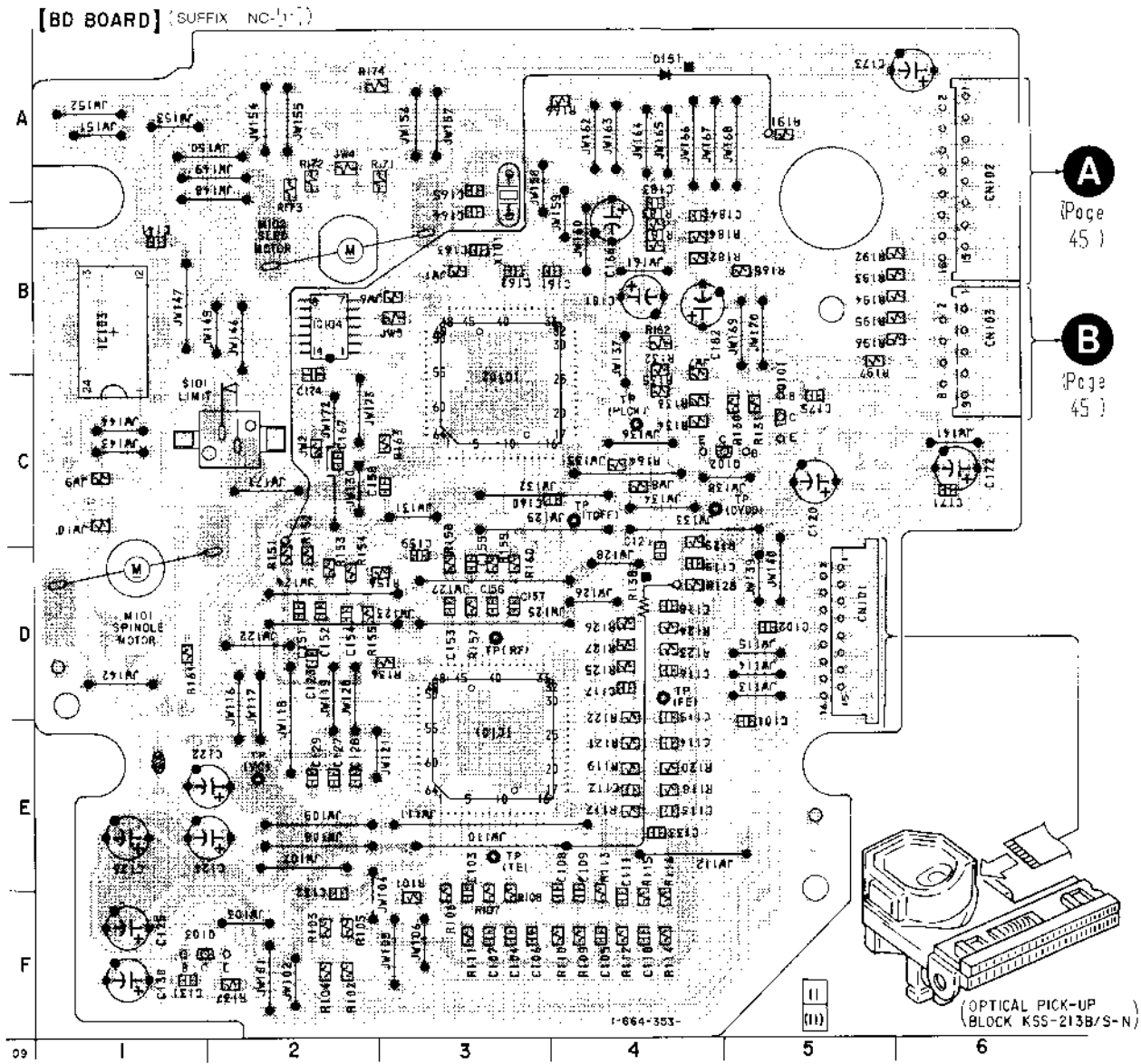

A
(Page 45)

B
(Page 45)

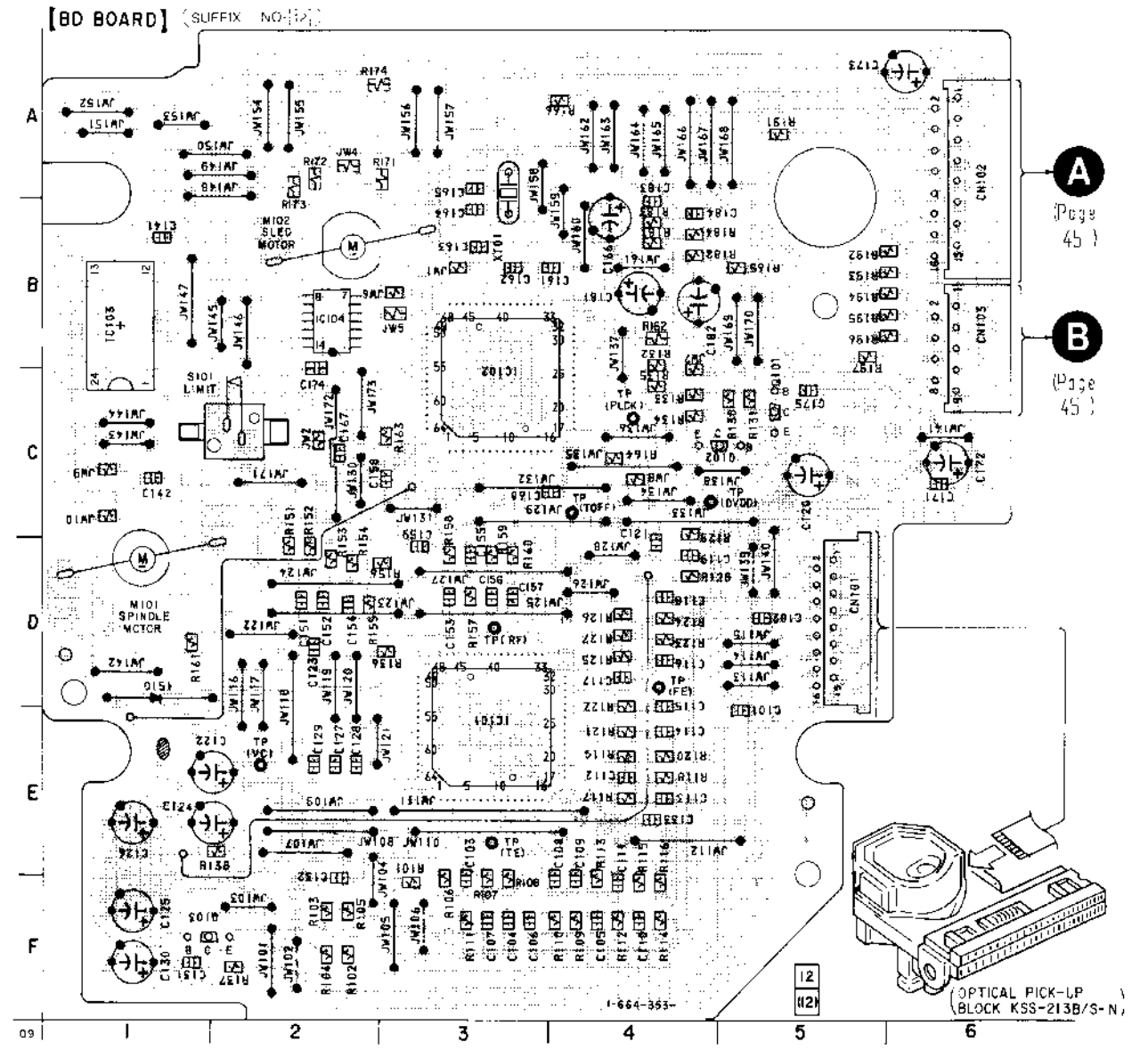

A
(Page 45)

B
(Page 45)

• Semiconductor Location

Ref. No.	Location
IC101	E-3
IC102	C-3
IC103	C-1
IC104	C-2
Q101	C-5
Q102	C-5
Q103	F-2

• Indication of transistor

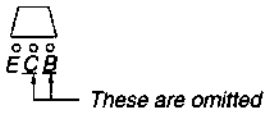

7-5. SCHEMATIC DIAGRAM — BD SECTION —

- See page 29 for Waveforms.
- See page 30 for IC Block Diagrams.

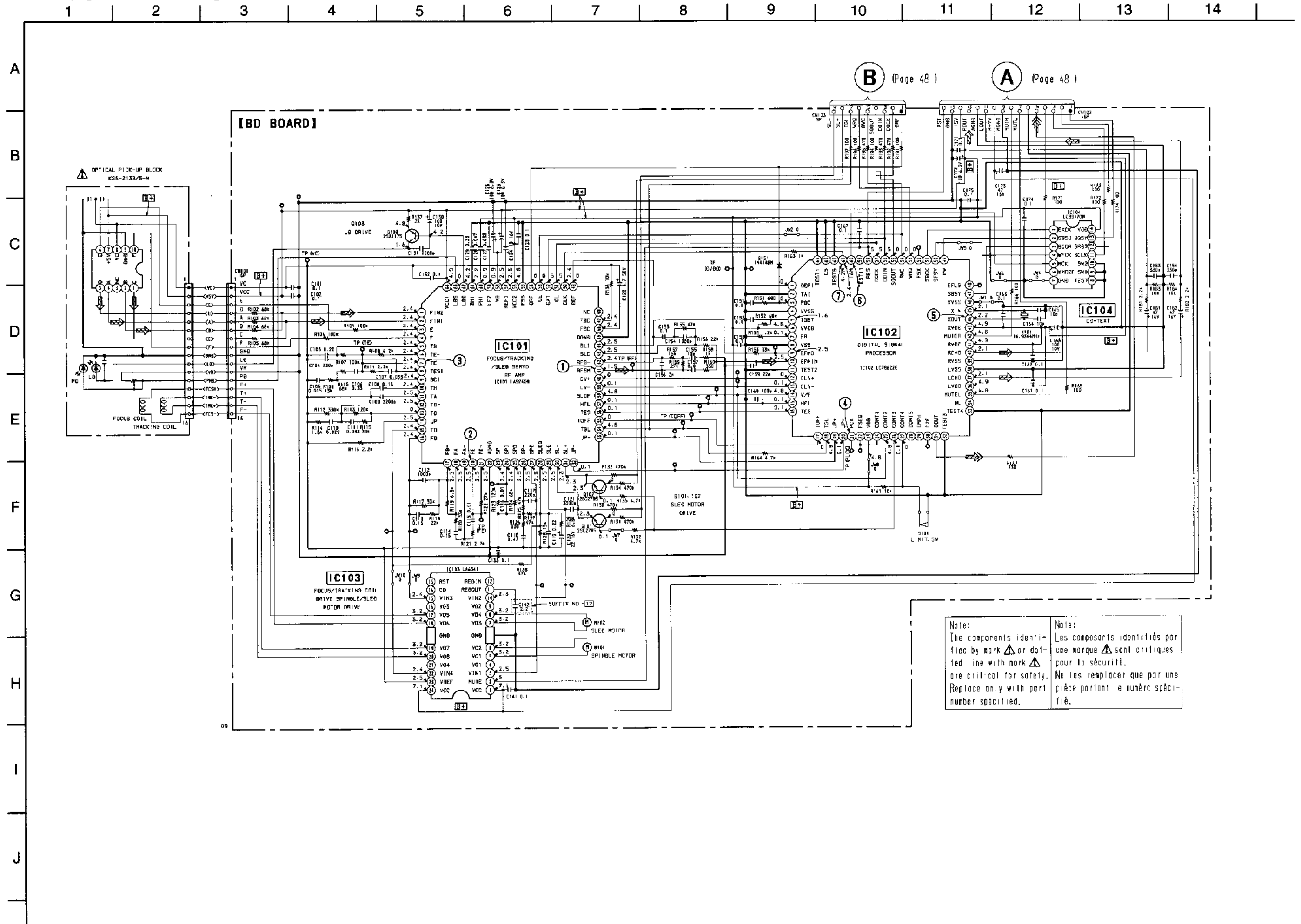

Note: The components identified by mark Δ or dotted line with mark Δ are critical for safety. Replace any with part number specified.

Note: Les composants identifiés par une marque Δ sont critiques pour la sécurité. Ne les remplacer que par une pièce portant le numéro spécifié.

7-6. PRINTED WIRING BOARD — AUDIO SECTION —
• See page 28 for Circuit Boards Location.

• Semiconductor Location

Ref. No.	Location
D201	D-6
D202	C-6
D203	D-6
D204	D-6
D205	C-6
D701	A-9
D801	E-6
D802	E-6
D841	B-13
D842	A-13
D843	A-13
IC301	C-9
IC302	C-8
IC401	D-9
IC402	D-8
IC701	A-10
Q301	B-9
Q302	B-9
Q303	B-7
Q331	C-9
Q401	B-8
Q402	B-8
Q403	B-7
Q431	D-8
Q701	A-9
Q802	E-7
Q803	E-6

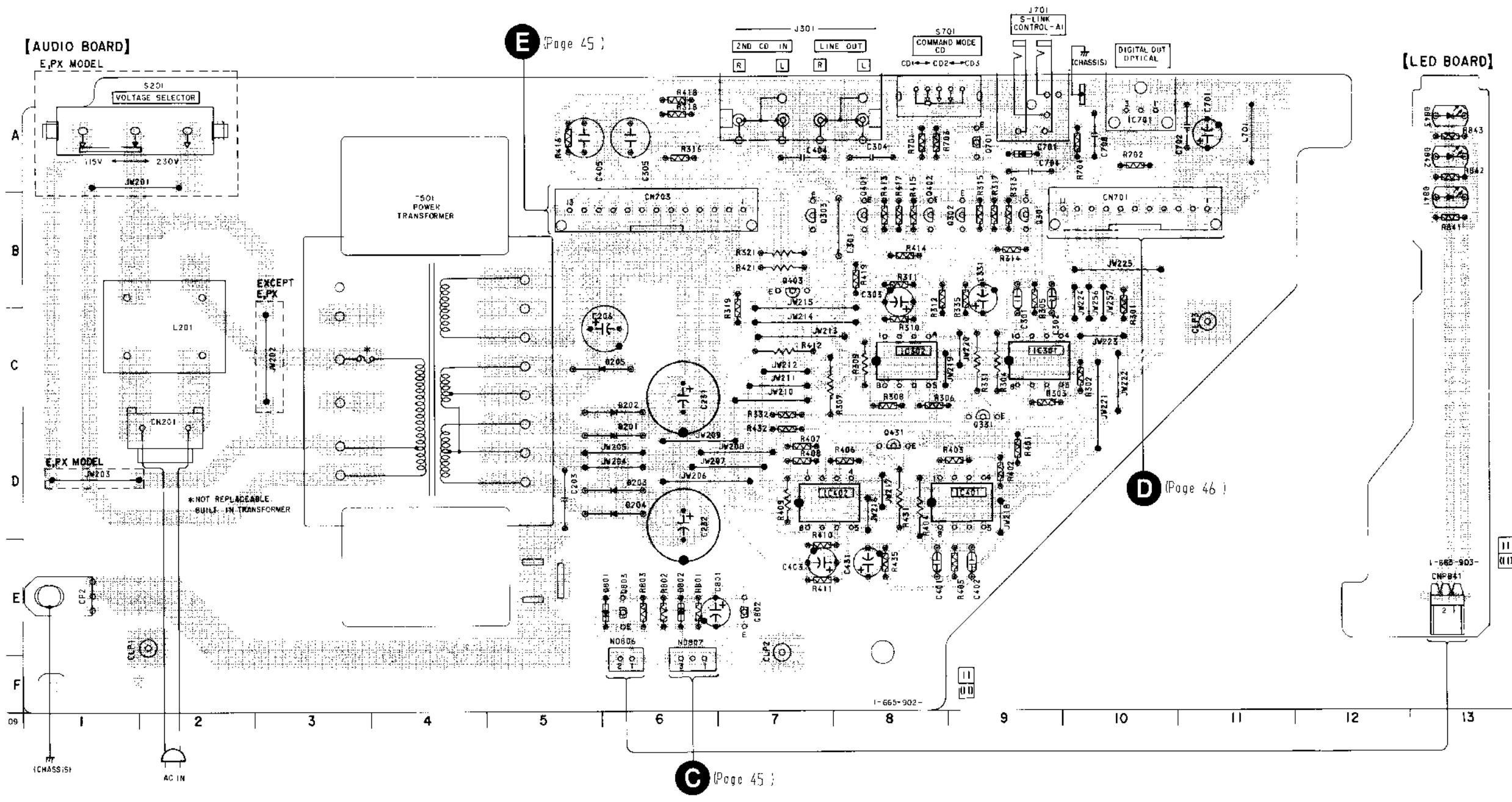

• Indication of transistor

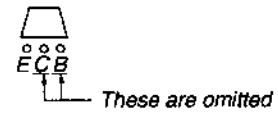

7-7. SCHEMATIC DIAGRAM — AUDIO SECTION —

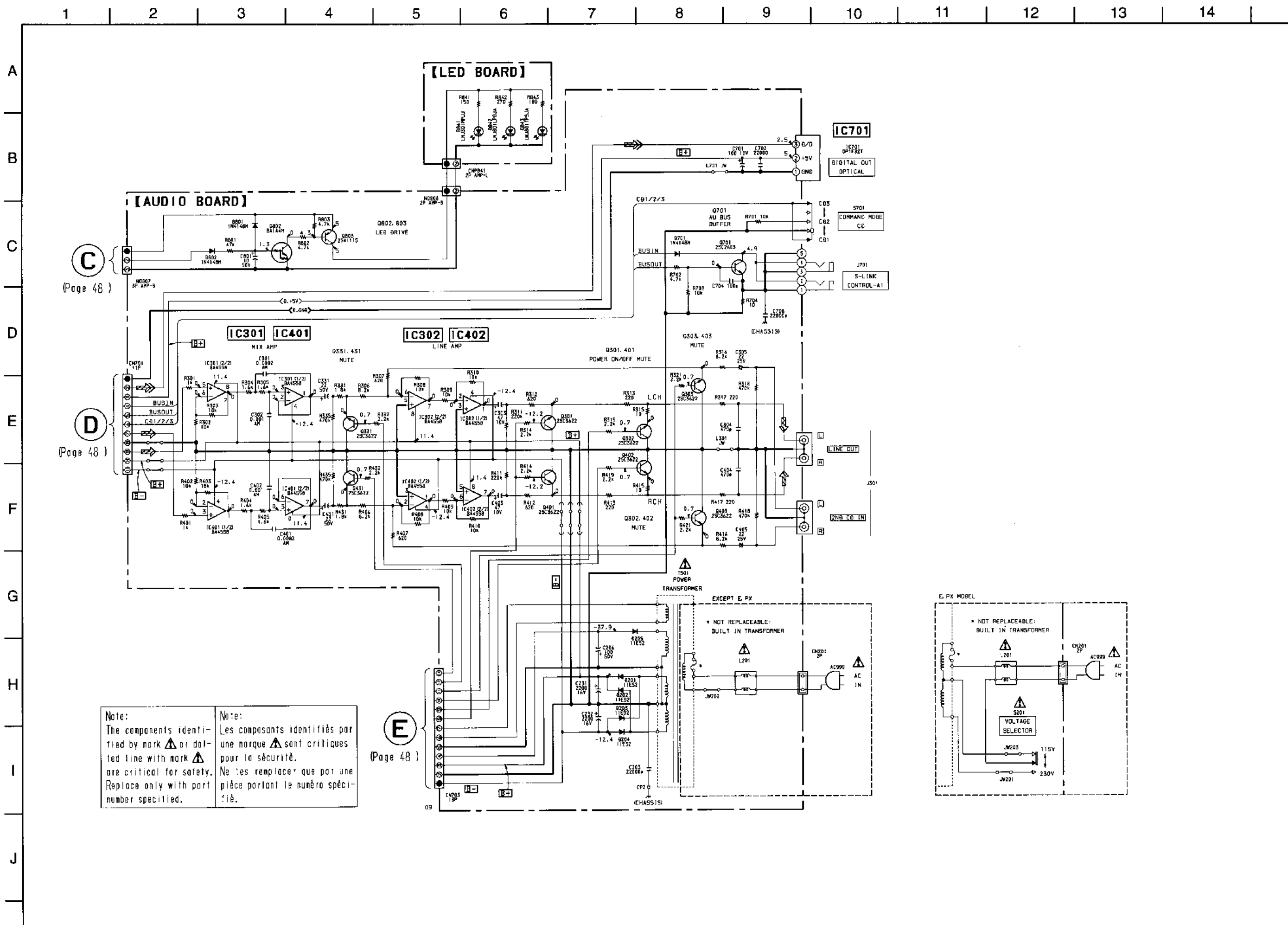

Note:
The components identified by mark Δ or dotted line with mark Δ are critical for safety. Replace only with part number specified.

Note:
Les composants identifiés par une marque Δ sont critiques pour la sécurité. Ne les remplacer que par une pièce portant le numéro spécifié.

(Page 48)

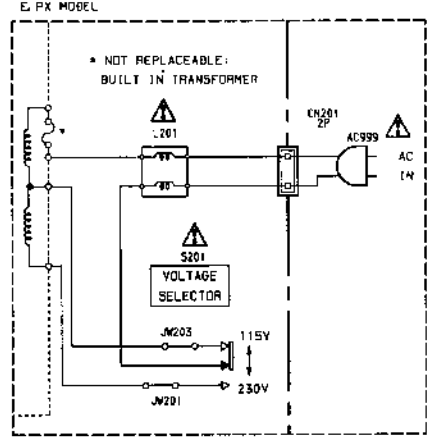

7-8. PRINTED WIRING BOARD — MAIN SECTION —

• See page 28 for Circuit Boards Location.

• Semiconductor Location

Ref. No.	Location
D206	F-2
D207	E-2
D210	C-1
D211	D-1
D212	D-1
D304	F-1
D382	E-1
D404	F-1
D501	D-6
IC201	D-2
IC202	C-2
IC203	A-4
IC501	C-5
IC502	D-5
IC601	F-4
Q201	F-2
Q202	E-2
Q304	F-1
Q305	B-1
Q380	D-1
Q381	E-1
Q382	E-1
Q383	F-1
Q404	F-1
Q405	B-1
Q481	D-1
Q501	C-4
Q502	E-4
Q503	E-5

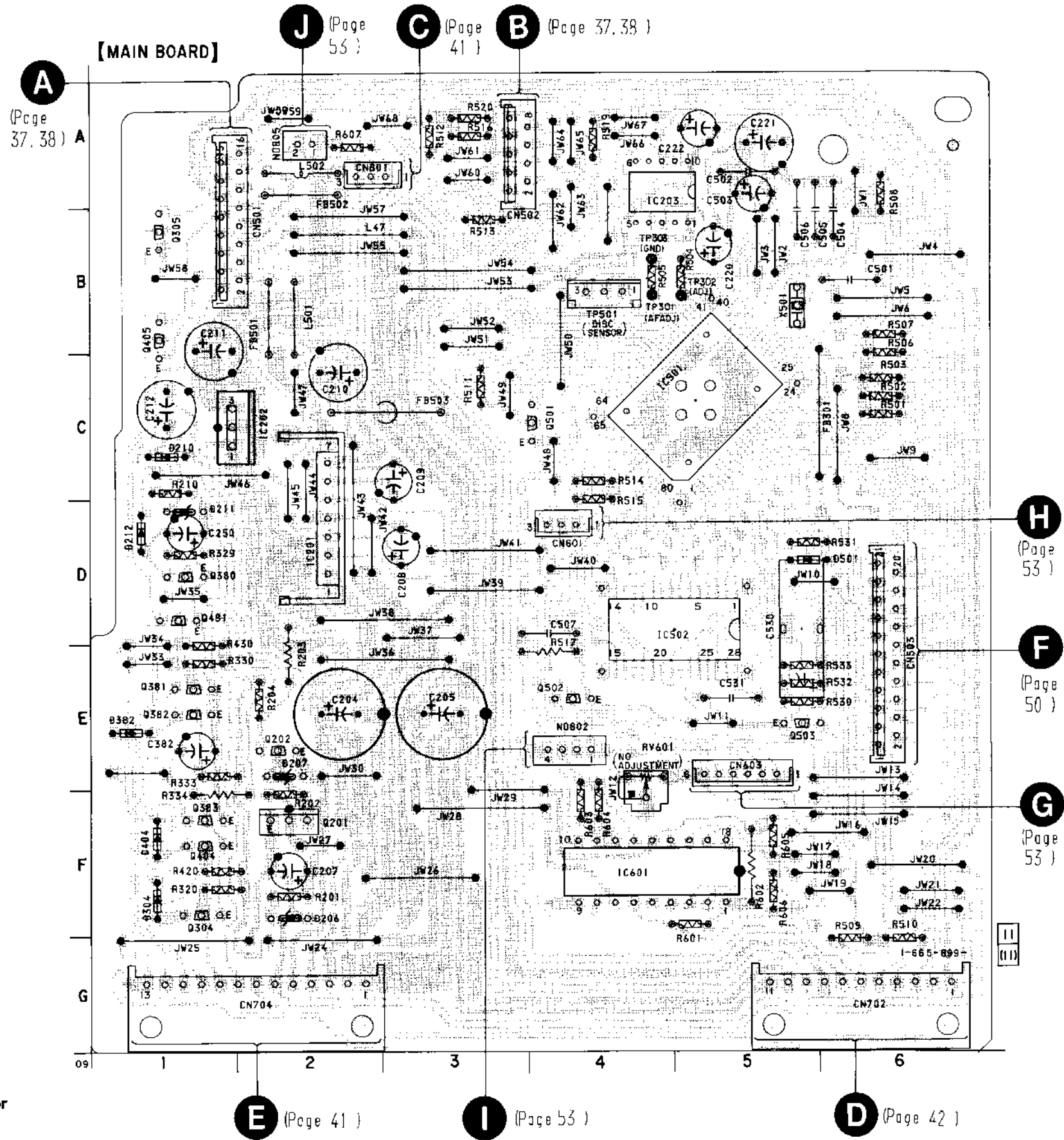

• Indication of transistor

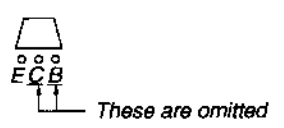

7-9. SCHEMATIC DIAGRAM — MAIN SECTION —

- See page 29 for Waveforms.
- See page 30 for IC Block Diagrams.
- See page 55 for IC Pin Functions.

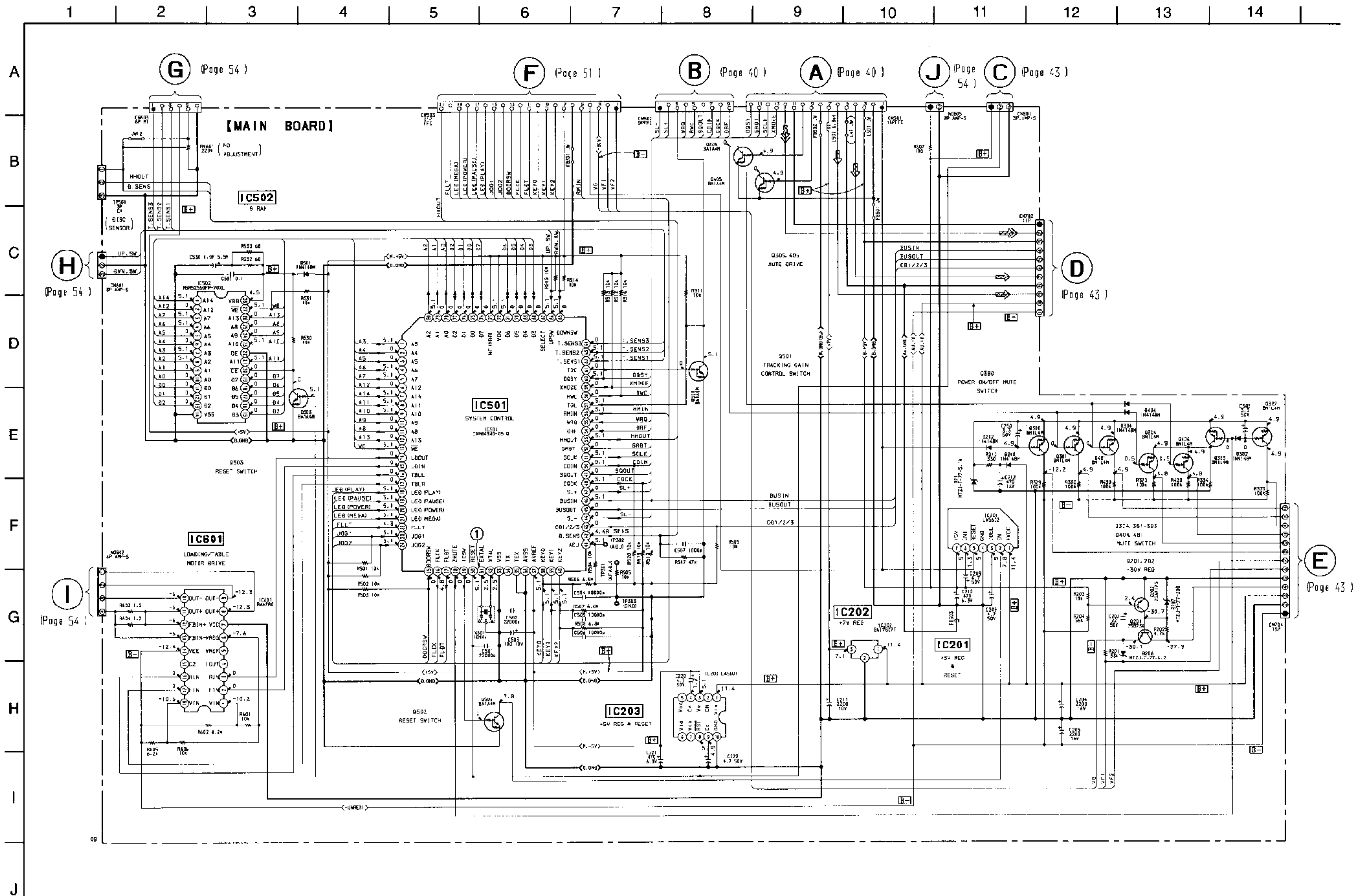

7-10. PRINTED WIRING BOARD — DISPLAY SECTION —
 • See page 28 for Circuit Boards Location.

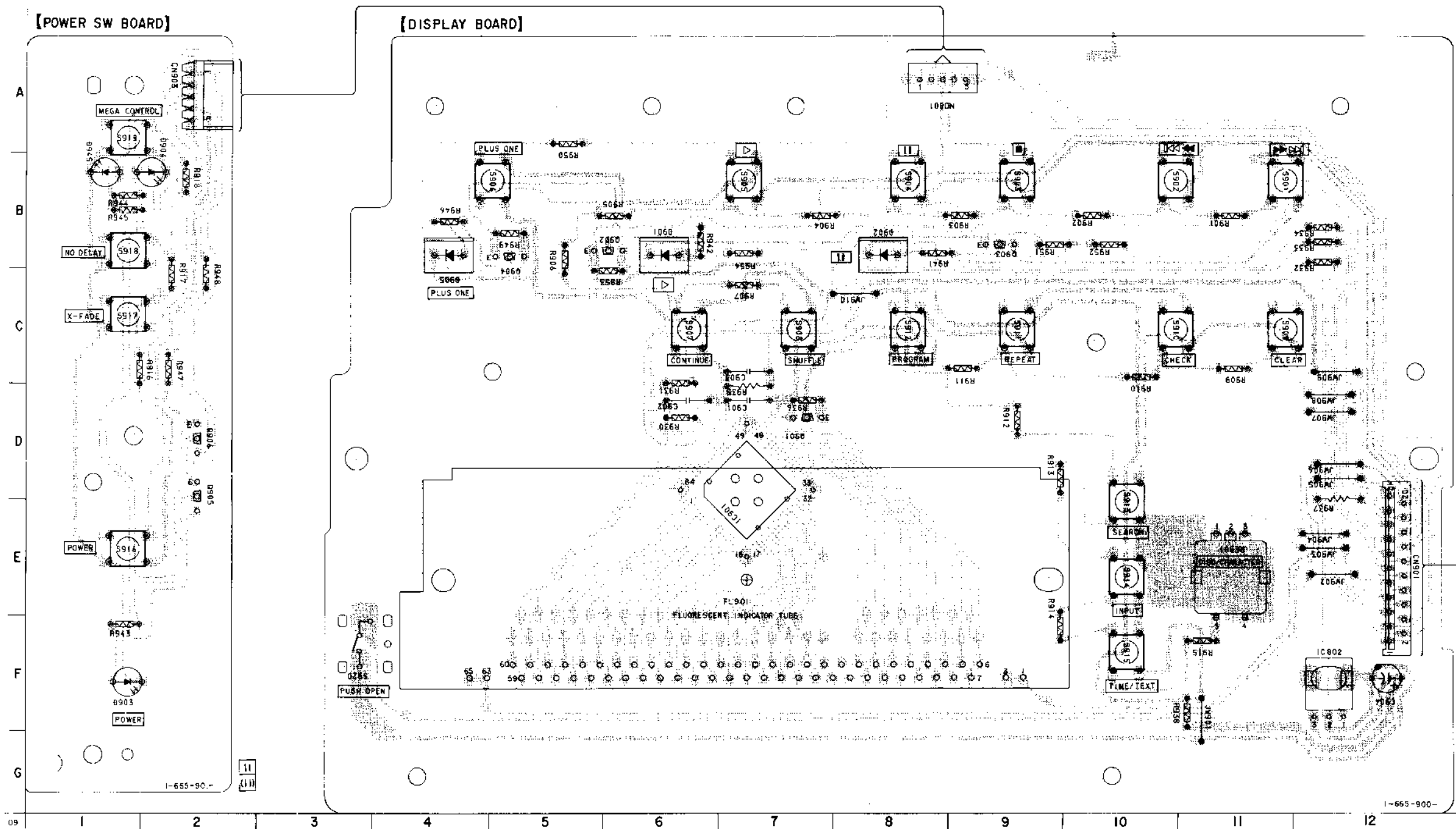

F
(Page 46)

• Indication of transistor

 These are omitted

• Semiconductor Location

Ref. No.	Location
D901	B-6
D902	B-8
D903	F-1
D904	B-2
D905	B-4
D945	B-1
IC802	F-12
IC901	E-7
Q901	D-7
Q902	B-6
Q903	B-9
Q904	B-5
Q905	D-2
Q906	D-2

7-11. SCHEMATIC DIAGRAM — DISPLAY SECTION —

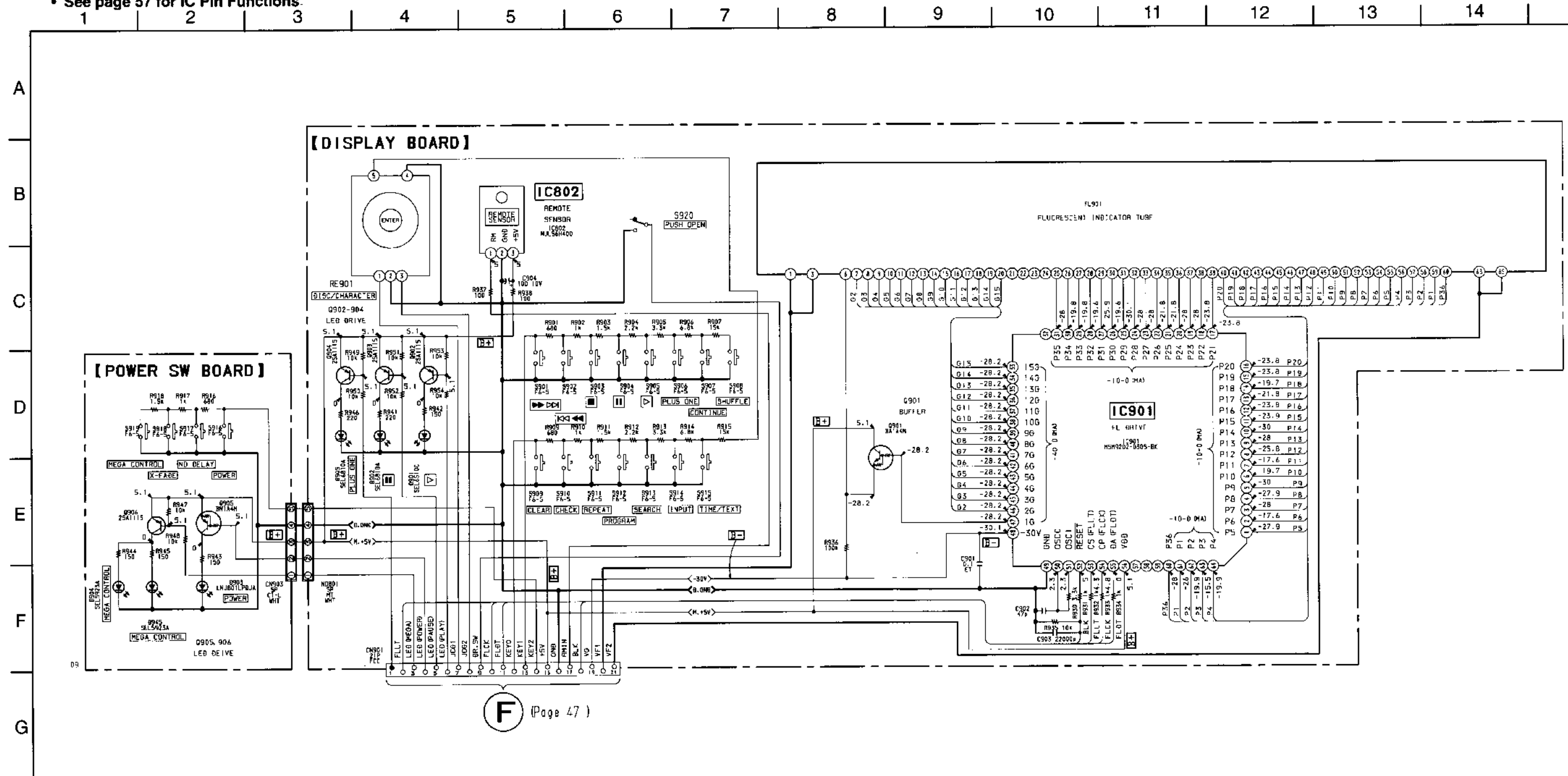
• See page 57 for IC Pin Functions.



F (Page 47)

7-12. PRINTED WIRING BOARD — SENSOR, MOTOR SECTION —
 • See page 28 for Circuit Boards Location.

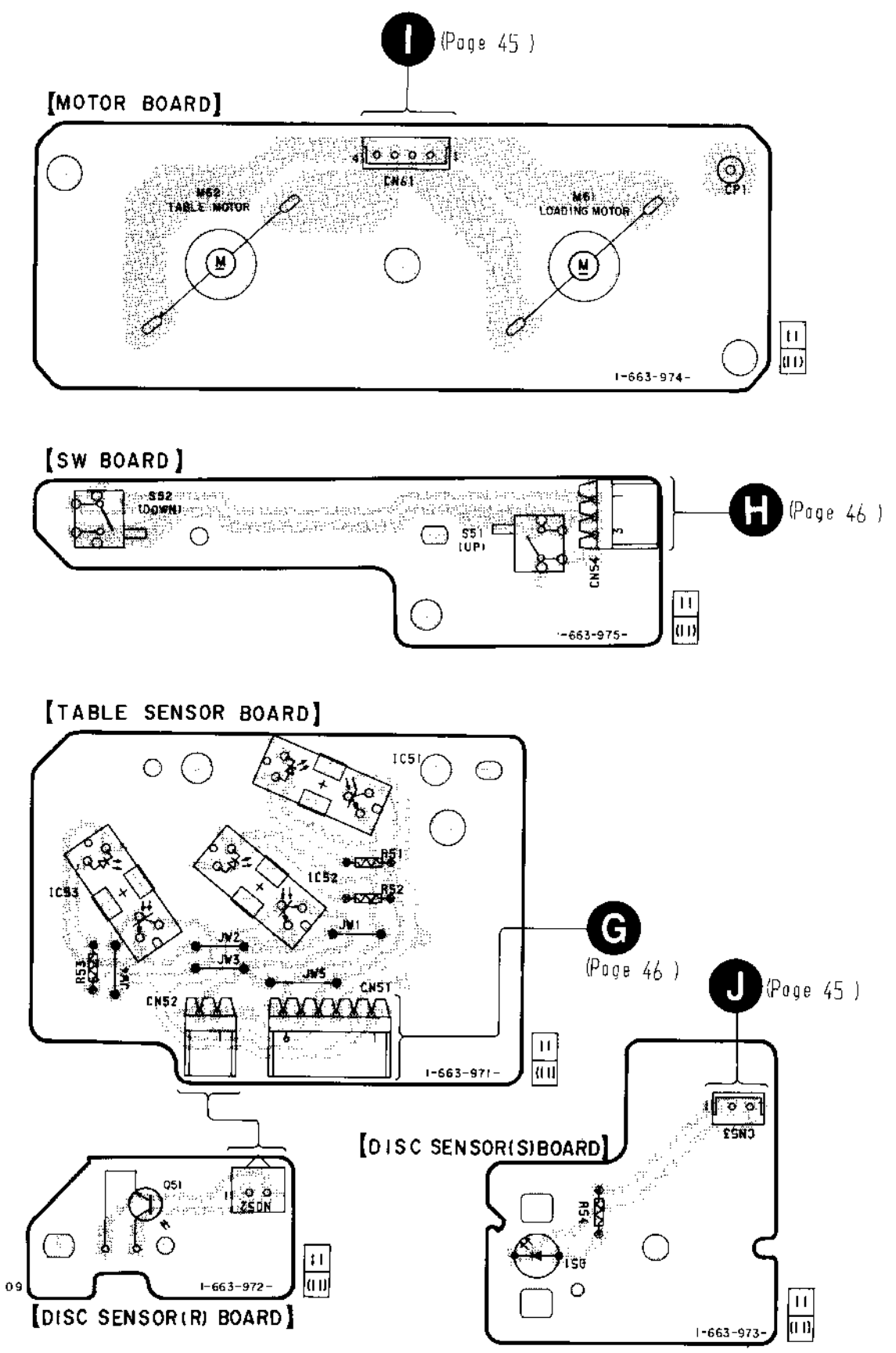

7-13. SCHEMATIC DIAGRAM — SENSOR, MOTOR SECTION —

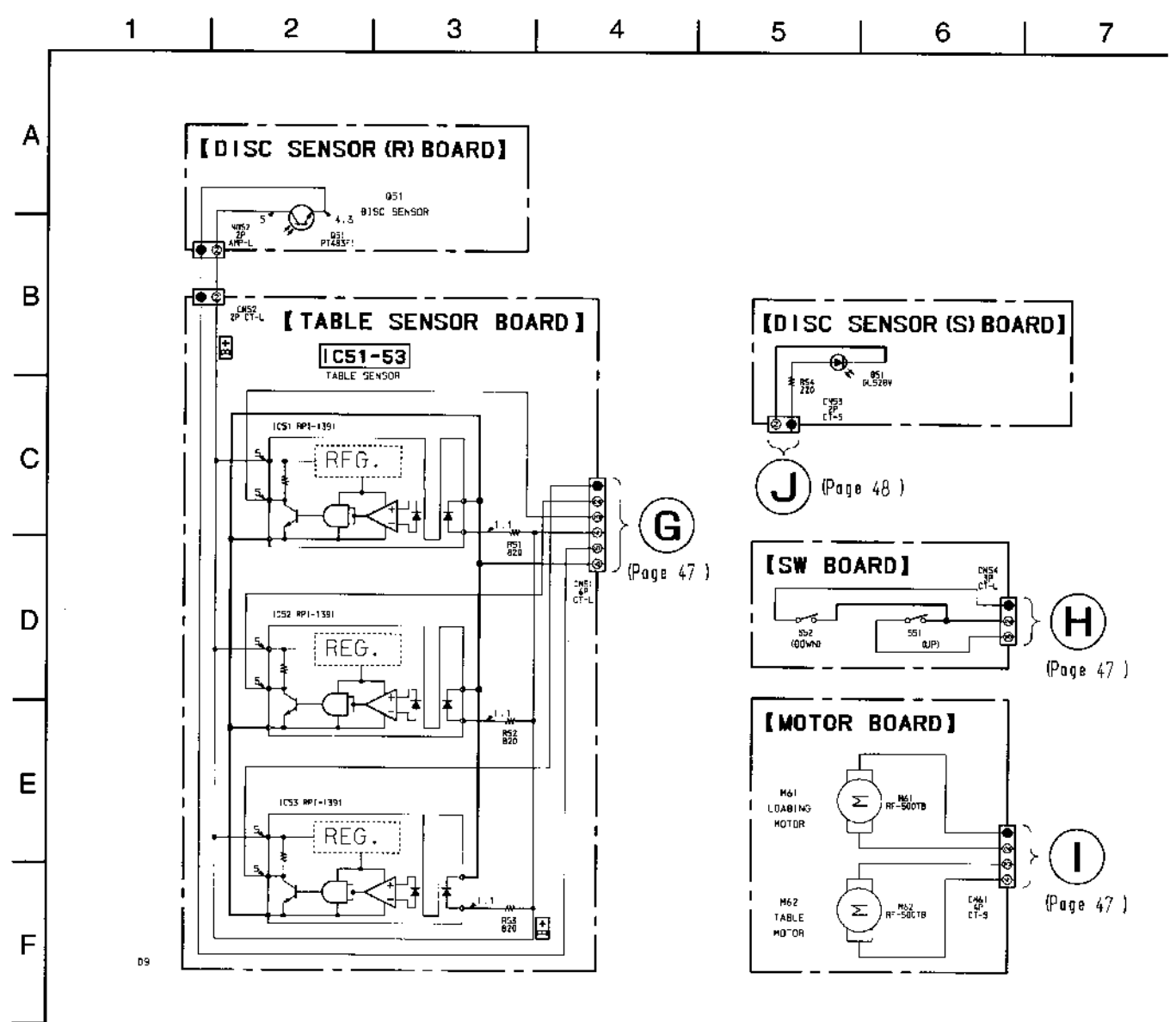

7-14. IC PIN FUNCTIONS

• IC501 SYSTEM CONTROL (CXP84340-051Q)

Pin No.	Pin Name	I/O	Function
1	A3	O	SRAM address output
2	A4	O	SRAM address output
3	A5	O	SRAM address output
4	A6	O	SRAM address output
5	A7	O	SRAM address output
6	A12	O	SRAM address output
7	A14	O	SRAM address output
8	A11	O	SRAM address output
9	A10	O	SRAM address output
10	A9	O	SRAM address output
11	A8	O	SRAM address output
12	A13	O	SRAM address output
13	$\overline{\text{WE}}$	O	SRAM write enable pin
14	LD OUT	O	Loading motor out
15	LD IN	O	Loading motor in
16	TBL L	O	Table motor
17	TBL R	O	Table motor
18	LED (PLAY)	O	PLAY LED output
19	LED (PAUSE)	O	PAUSE LED output
20	LED (POWER)	O	POWER LED output
21	LED (MEGA)	O	MEGA CONTROL LED output
22	FLLT	O	Fluorescent indicator tube driver IC latch output
23	JOG1	I	JOG input
24	JOG2	I	JOG input
25	DOOR SW	I	Front cover close sw
26	FLCK	O	Fluorescent indicator tube driver IC clock output
27	FLDT	O	Fluorescent indicator tube driver IC data output
28	ZMUTE	O	2nd input pin, mute output
29	ICSW	O	Output +5V
30	$\overline{\text{RESET}}$	I	Reset input
31	EXTAL	I	10Mhz supply pin
32	XTAL	I	10Mhz supply pin
33	Vss	-	Ground
34	TX	-	Not used
35	TEX	-	Ground
36	AVSS	-	Ground
37	AVREF	-	+5V power supply
38	KEY0	I	Key input 0
39	KEY1	I	Key input 1
40	KEY2	I	Key input 2

Pin No.	Pin Name	I/O	Function
41	ADJ	I	TEST pin (GND=ADJ/2.5V=AFADJ/4V=MECHANICAL ADJ)
42	D.SENS	I	DISC sensor input
43	CD1/2/3	I	CD 1/2/3/ sw input
44	SL-	O	BD sled output
45	BUSOUT	O	Contlor A1 output pin
46	BUSIN	I	Contlor A1 input pin
47	SL+	O	BD sled output
48	CQCK	O	BD clock output
49	SQOUT	I	BD SUBQ input
50	COIN	O	BD data output
51	SCLK	O	LC89170M clock output
52	SRDT	I	LC89170M data input
53	HHOUT	O	PLUS ONE LED output
54	DRF	I	BD DRF input (FOK input)
55	WRQ	I	BD sub Q sink input
56	RMIN	I	Remote controller input
57	TGL	I	BD Tracking gain high input
58	RWC	O	BD Latch output
59	XMODE	O	LC89170M Reset output
60	DQSY	I	LC89170M data sink input
61	TGC	O	BD Tracking gain control
62	T.SENS1	I	Tabc sensor input
63	T.SENS2	I	Tabc sensor input
64	T.SENS3	I	Tabc sensor input
65	DOWNSW	I	Loading out sw input
66	UPSW	I	Loading in sw input
67	SELECT	I	Select input
68	D3	I/O	SRAM data input/output
69	D4	I/O	SRAM data input/output
70	D5	I/O	SRAM data input/output
71	D6	I/O	SRAM data input/output
72	VDD	-	+5V power supply
73	NC (VDD)	-	Not used
74	D7	I/O	SRAM data input/output
75	D0	I/O	SRAM data input/output
76	D1	I/O	SRAM data input/output
77	D2	I/O	SRAM data input/output
78	A0	O	SRAM address output
79	A1	O	SRAM address output
80	A2	O	SRAM address output

• IC901 FL DRIVE (MSM9202-03GK-BK)

Pin No.	Pin Name	I/O	Function
1	P5	O	Fluorescent display tube anode electrodedrive output terminal
2	P6	O	Fluorescent display tube anode electrodedrive output terminal
3	P7	O	Fluorescent display tube anode electrodedrive output terminal
4	P8	O	Fluorescent display tube anode electrodedrive output terminal
5	P9	O	Fluorescent display tube anode electrodedrive output terminal
6	P10	O	Fluorescent display tube anode electrodedrive output terminal
7	P11	O	Fluorescent display tube anode electrodedrive output terminal
8	P12	O	Fluorescent display tube anode electrodedrive output terminal
9	P13	O	Fluorescent display tube anode electrodedrive output terminal
10	P14	O	Fluorescent display tube anode electrodedrive output terminal
11	P15	O	Fluorescent display tube anode electrodedrive output terminal
12	P16	O	Fluorescent display tube anode electrodedrive output terminal
13	P17	O	Fluorescent display tube anode electrodedrive output terminal
14	P18	O	Fluorescent display tube anode electrodedrive output terminal
15	P19	O	Fluorescent display tube anode electrodedrive output terminal
16	P20	O	Fluorescent display tube anode electrodedrive output terminal
17	P21	O	Fluorescent display tube anode electrodedrive output terminal
18	P22	O	Fluorescent display tube anode electrodedrive output terminal
19	P23	O	Fluorescent display tube anode electrodedrive output terminal
20	P24	O	Fluorescent display tube anode electrodedrive output terminal
21	P25	O	Fluorescent display tube anode electrodedrive output terminal
22	P26	O	Fluorescent display tube anode electrodedrive output terminal
23	P27	O	Fluorescent display tube anode electrodedrive output terminal
24	P28	O	Fluorescent display tube anode electrodedrive output terminal
25	P29	O	Fluorescent display tube anode electrodedrive output terminal
26	P30	O	Fluorescent display tube anode electrodedrive output terminal
27	P31	O	Fluorescent display tube anode electrodedrive output terminal
28	P32	O	Fluorescent display tube anode electrodedrive output terminal
29	P33	O	Fluorescent display tube anode electrodedrive output terminal
30	P34	O	Fluorescent display tube anode electrodedrive output terminal
31	P35	O	Fluorescent display tube anode electrodedrive output terminal
32	NC	O	Not used
33	15G	O	Fluorescent display tube grid electrodedrive output terminal
34	14G	O	Fluorescent display tube grid electrodedrive output terminal
35	13G	O	Fluorescent display tube grid electrodedrive output terminal
36	12G	O	Fluorescent display tube grid electrodedrive output terminal
37	11G	O	Fluorescent display tube grid electrodedrive output terminal
38	10G	O	Fluorescent display tube grid electrodedrive output terminal
39	9G	O	Fluorescent display tube grid electrodedrive output terminal
40	8G	O	Fluorescent display tube grid electrodedrive output terminal

Pin No.	Pin Name	I/O	Function
41	7G	O	Fluorescent display tube grid electrodedrive output terminal
42	6G	O	Fluorescent display tube grid electrodedrive output terminal
43	5G	O	Fluorescent display tube grid electrodedrive output terminal
44	4G	O	Fluorescent display tube grid electrodedrive output terminal
45	3G	O	Fluorescent display tube grid electrodedrive output terminal
46	2G	O	Fluorescent display tube grid electrodedrive output terminal
47	1G	O	Fluorescent display tube grid electrodedrive output terminal
48	-30V	-	Fluorescent display tube drive power supply
49	GND	-	Ground
50	OSC0	I	CR Oscillation pin
51	OSC1	O	CR Oscillation pin
52	$\overline{\text{RESET}}$	I	Reset input pin
53	CS (FLLT)	I	Chip select pin
54	CP (FLCK)	I	Shift clock input pin
55	DA (FLDT)	I	Serial data input pin
56	VDD	-	Logic power supply
57	NC	O	Not used
58	NC	O	Not used
59	NC	O	Not used
60	P36	O	Fluorescent display tube anode electrodedrive output terminal
61	P1	O	Fluorescent display tube anode electrodedrive output terminal
62	P2	O	Fluorescent display tube anode electrodedrive output terminal
63	P3	O	Fluorescent display tube anode electrodedrive output terminal
64	P4	O	Fluorescent display tube anode electrodedrive output terminal

- Abbreviation
CR : Condenser and resistor

SECTION 8 EXPLODED VIEWS

NOTE:

- Items marked “*” are not stocked since they are seldom required for routine service. Some delay should be anticipated when ordering these items.
- The mechanical parts with no reference number in the exploded views are not supplied.

- Hardware (# mark) list and accessories and packing materials are given in the last of this parts list.
- Abbreviation
 CND : Canadian model
 SP : Singapore model
 AUS : Australian model

The components identified by mark \triangle or dotted line with mark \triangle are critical for safety. Replace only with part number specified.

Les composants identifiés par une marque \triangle sont critiques pour la sécurité.

Ne les remplacer que par une pièce portant le numéro spécifié.

8-1. CASE SECTION

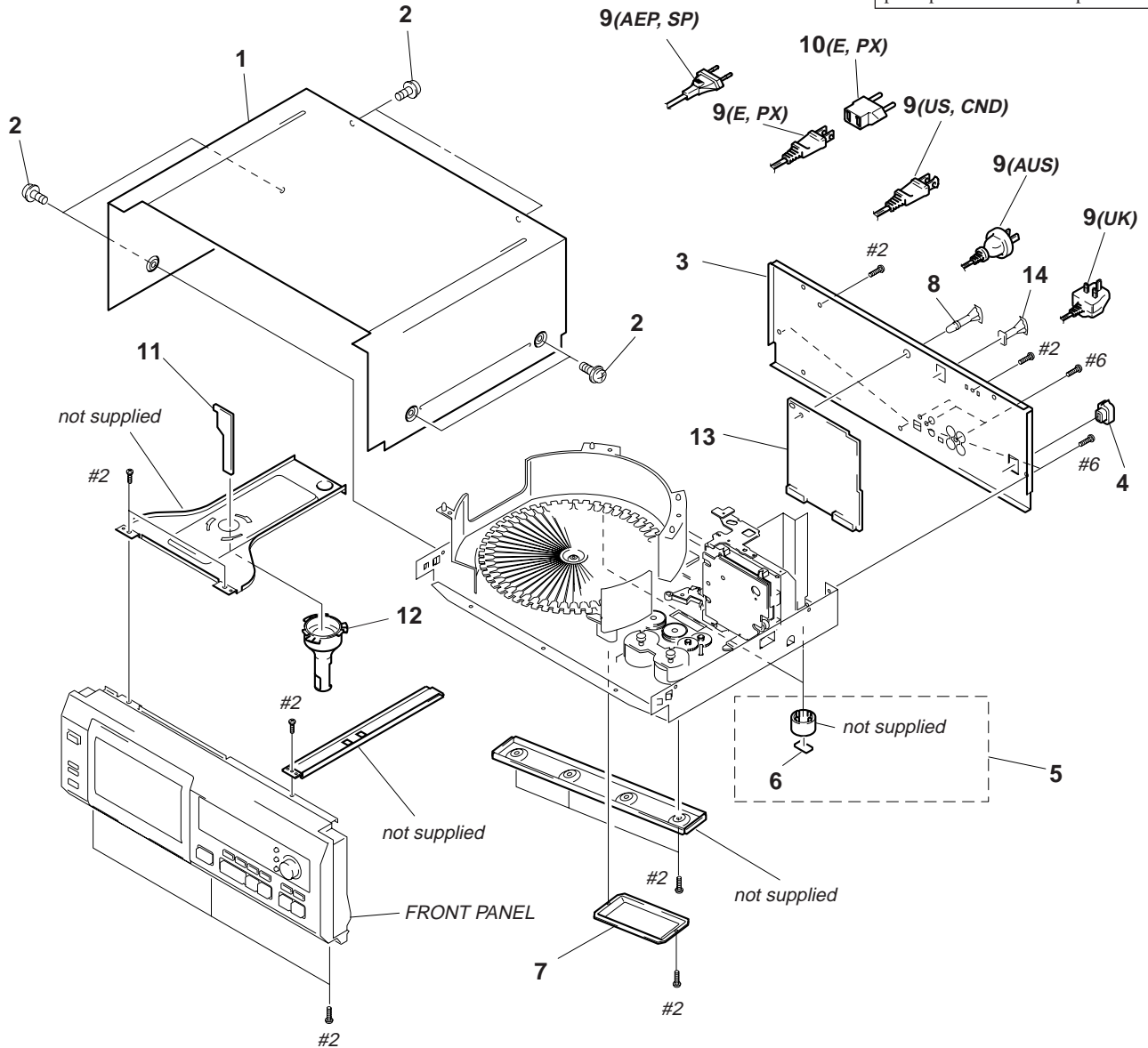

Ref. No.	Part No.	Description	Remark	Ref. No.	Part No.	Description	Remark
* 1	4-987-999-11	CASE		* 8	3-704-198-61	SUPPORT, PC	
2	3-704-366-01	SCREW (CASE) (M3X8)		\triangle 9	1-558-943-41	CORD, POWER (E,PX)	
* 3	4-991-160-01	PANEL, BACK (US)		\triangle 9	1-575-651-21	CORD, POWER (AEP,SP)	
* 3	4-991-160-11	PANEL, BACK (CND)		\triangle 9	1-590-926-11	CORD, POWER (US,CND)	
* 3	4-991-160-21	PANEL, BACK (AEP)		\triangle 9	1-696-845-11	CORD, POWER (AUS)	
* 3	4-991-160-31	PANEL, BACK (AUS)		\triangle 9	1-751-529-11	CORD, POWER (UK)	
* 3	4-991-160-41	PANEL, BACK (E,PX)		\triangle 10	1-569-007-11	ADAPTOR, CONVERSION 2P (E,PX)	
* 3	4-991-160-51	PANEL, BACK (SP)		* 11	1-665-903-11	LED BOARD	
* 3	4-991-160-61	PANEL, BACK (UK)		* 12	X-4948-515-1	ILLUMINATION ASSY	
* 4	3-703-244-00	BUSHING (2104), CORD (EXCEPT E,PX)		* 13	A-4699-679-A	MAIN BOARD, COMPLETE (US,CND)	
* 4	3-703-571-11	BUSHING (S) (4516), CORD (E,PX)		* 13	A-4699-682-A	MAIN BOARD, COMPLETE (AEP,UK,SP,AUS)	
5	X-3371-435-1	FOOT (SMALL) ASSY		* 13	A-4699-683-A	MAIN BOARD, COMPLETE (E,PX)	
* 6	4-978-398-21	CUSHION		* 14	4-990-895-11	SUPPORT (P TYPE), LSR	
* 7	4-988-534-01	COVER, MOTOR					

8-2. FRONT PANEL SECTION

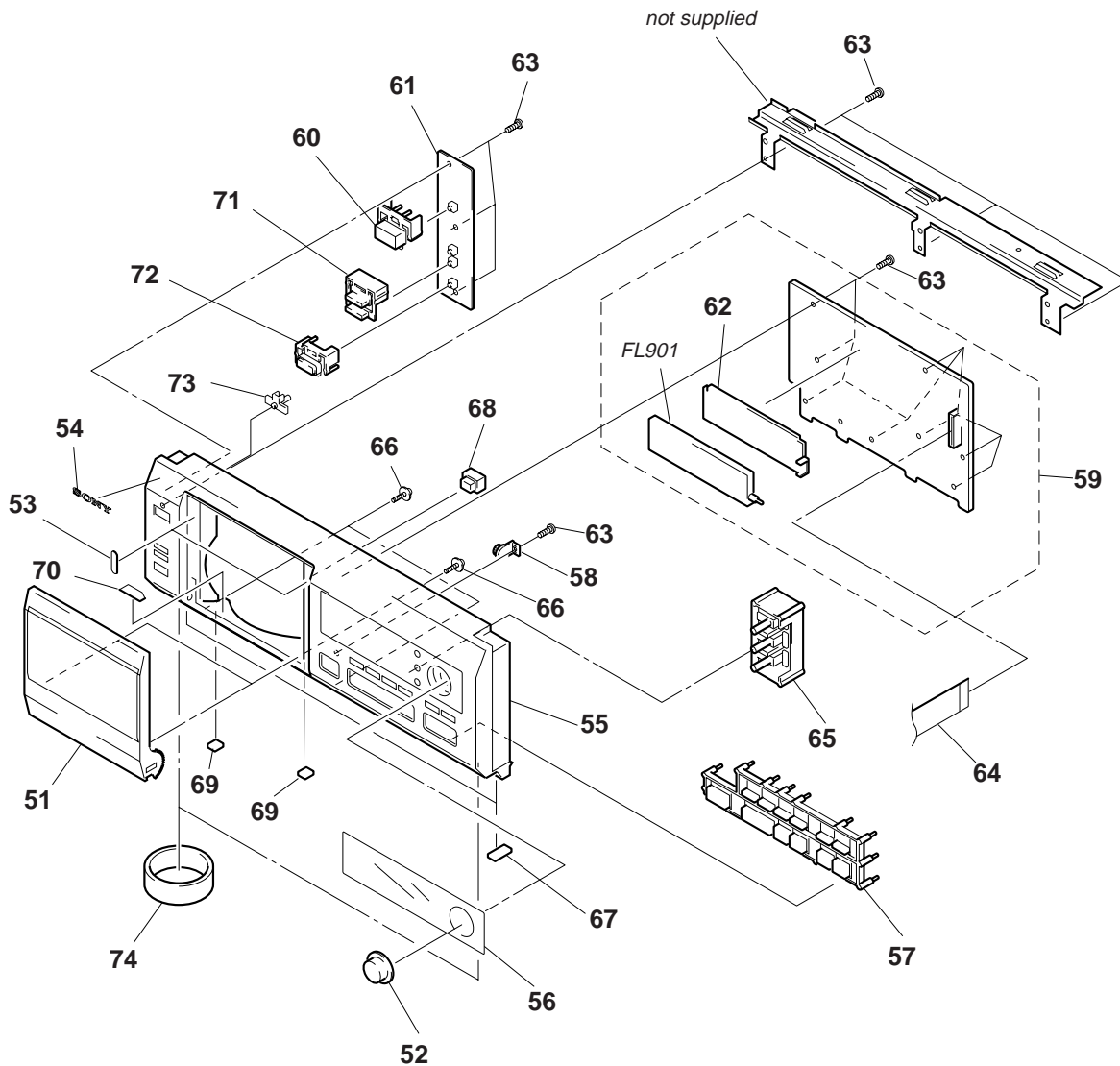

Ref. No.	Part No.	Description	Remark	Ref. No.	Part No.	Description	Remark
51	X-4948-084-1	LID ASSY		64	1-773-174-11	WIRE (FLAT TYPE) (21 CORE)	
52	4-987-941-01	KNOB (JOG)		65	4-991-154-01	BUTTON (3 GANG)	
* 53	4-988-674-01	CUSHION (CLOSE)		66	4-933-134-61	SCREW (+PTPWH M2.6X6)	
54	3-008-600-01	EMBLEM (5-AR), SONY		* 67	4-978-398-21	CUSHION	
55	4-987-877-11	PANEL, FRONT		68	4-989-312-01	LATCH, NS	
56	4-987-955-11	WINDOW (FL)		69	4-988-675-01	CUSHION (STOPPER)	
57	X-4948-480-1	BUTTON (MAIN) ASSY		* 70	4-991-854-01	LABEL (DISC)	
58	3-354-963-01	DAMPER		71	4-991-153-01	BUTTON (2 GANG)	
* 59	A-4699-676-A	DISPLAY BOARD, COMPLETE		72	4-987-778-01	BUTTON (MEGA-CON)	
60	4-991-152-01	BUTTON (POWER)		73	4-991-156-01	INDICATOR (POWER)	
* 61	1-665-901-11	POWER SW BOARD		74	4-977-593-01	RING (DIA, 50), ORNAMENTAL (EXCEPT US)	
* 62	4-987-942-01	HOLDER, FL TUBE		FL901	1-517-678-11	INDICATOR TUBE, FLUORESCENT	
63	4-951-620-01	SCREW (2.6X8), +BVTP					

8-3. CHASSIS SECTION

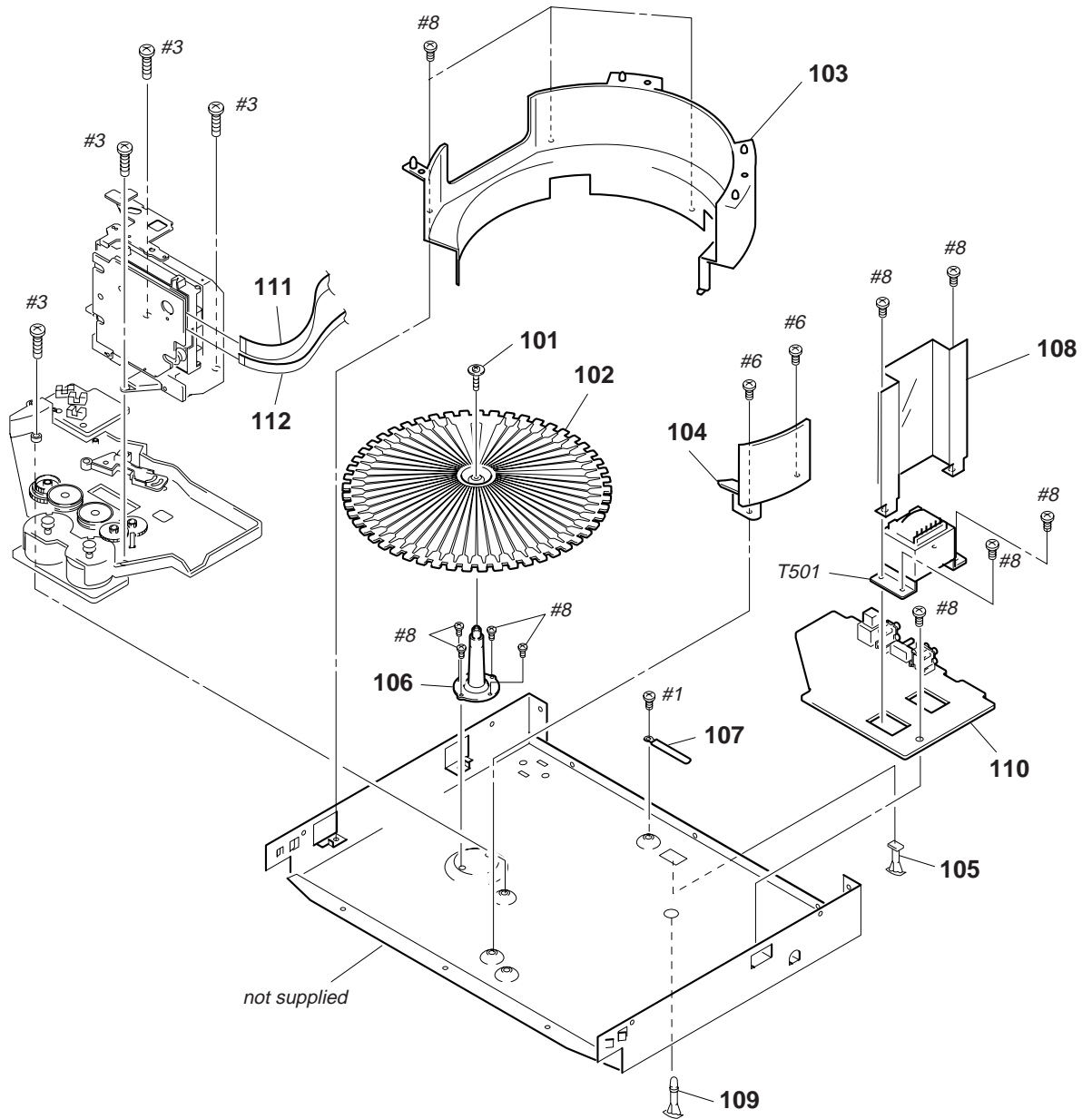

<p>The components identified by mark \triangle or dotted line with mark \triangle are critical for safety. Replace only with part number specified.</p>	<p>Les composants identifiés par une marque \triangle sont critiques pour la sécurité. Ne les remplacer que par une pièce portant le numéro spécifié.</p>
---	--

Ref. No.	Part No.	Description	Remark	Ref. No.	Part No.	Description	Remark
101	4-957-577-21	SCREW PTP WH (2.6X8) (DIA. 10)		* 110	A-4699-678-A	AUDIO BOARD, COMPLETE (US,CND)	
102	4-988-434-01	TABLE (50)		* 110	A-4699-681-A	AUDIO BOARD, COMPLETE (AEP,UK,SP,AUS)	
103	4-990-028-01	RING (A)		* 110	A-4699-684-A	AUDIO BOARD, COMPLETE (E,PX)	
104	4-990-029-01	RING (B)		111	1-782-465-11	WIRE (FLAT TYPE) (16 CORE) (300mm)	
* 105	4-990-895-01	SUPPORT (P TYPE), LSR		112	1-769-921-11	WIRE (FLAT TYPE) (9 CORE)	
106	4-988-439-01	HOLDER, TABLE		\triangle T501	1-431-333-11	TRANSFORMER, POWER (US,CND)	
107	3-703-397-01	STOPPER, WIRING		\triangle T501	1-431-334-11	TRANSFORMER, POWER (AEP,UK,SP,AUS)	
* 108	4-991-167-01	COVER, TRANSFORMER		\triangle T501	1-431-335-11	TRANSFORMER, POWER (E,PX)	
* 109	3-704-198-51	SUPPORT, PC					

8-4. MECHANISM DECK SECTION 1 (CDM-46TE)

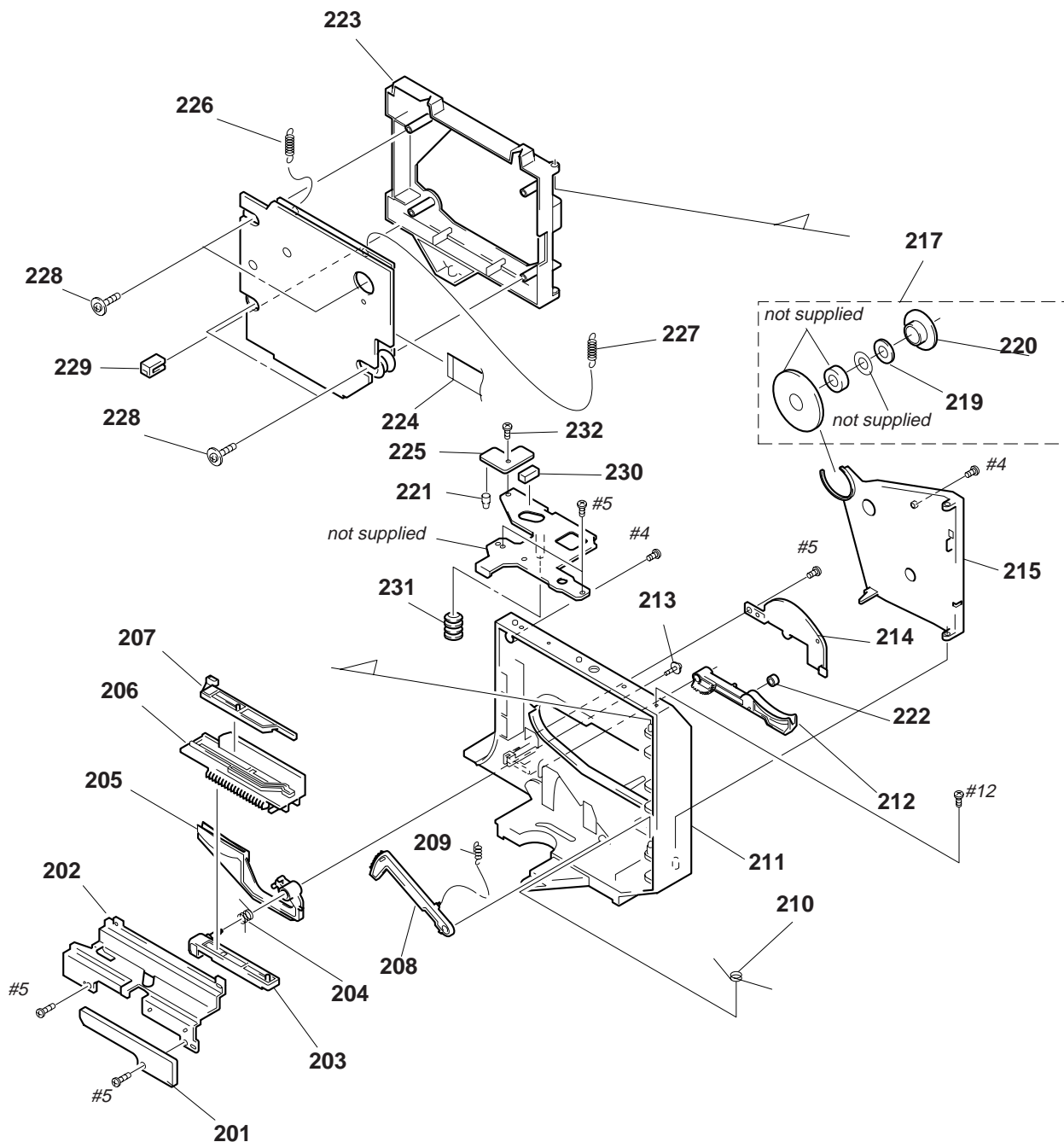

Ref. No.	Part No.	Description	Remark	Ref. No.	Part No.	Description	Remark
* 201	1-663-975-11	SW BOARD		217	A-4672-385-A	MAGNET ASSY	
* 202	4-988-427-01	COVER, CAM		219	4-960-633-01	YOKE (MAGNET)	
203	4-988-420-01	SLIDER (LOADING)		220	4-960-632-11	PULLEY (B)	
204	4-988-436-01	SPRING (LOADING), TORSION		* 221	4-976-473-01	HOLDER (LED-S)	
205	4-988-418-01	HOLDER (A), DISC		222	4-988-431-01	ROLLER (DISC)	
* 206	4-988-417-01	SLIDER (CAM)		223	X-4948-019-1	HOLDER ASSY, BU	
207	4-988-433-01	SLIDER (LOCK)		224	1-777-874-11	WIRE (FLAT TYPE) (16 CORE) (75mm)	
208	X-4948-020-1	LEVER ASSY, LOADING		* 225	1-663-973-11	DISC SENSOR (S) BOARD	
209	4-988-438-01	SPRING (LEVER), TENSION COIL		226	4-988-440-01	SPRING (F-1), TENSION COIL	
210	4-988-437-01	SPRING (HOLDER), TORSION		227	4-988-441-01	SPRING (F-2), TENSION COIL	
* 211	4-988-416-01	BASE, LOADING		228	4-957-577-21	SCREW PTP WH (2.6X8) (DIA. 10)	
212	4-988-419-01	HOLDER (B), DISC		229	4-992-413-01	STOPPER	
213	4-992-069-01	SCREW +BTP 2.6X8 TYPE2 N-S		230	4-924-042-41	SPACER (TC)	
* 214	4-988-454-01	COVER (LEVER)		231	3-910-095-11	RUBBER, VIBRATION PROOF	
* 215	4-988-421-01	HOLDER (MAGNET)		232	4-951-620-01	SCREW (2.6x8), +BVTP	

8-5. MECHANISM DECK SECTION 2 (CDM-46TE)

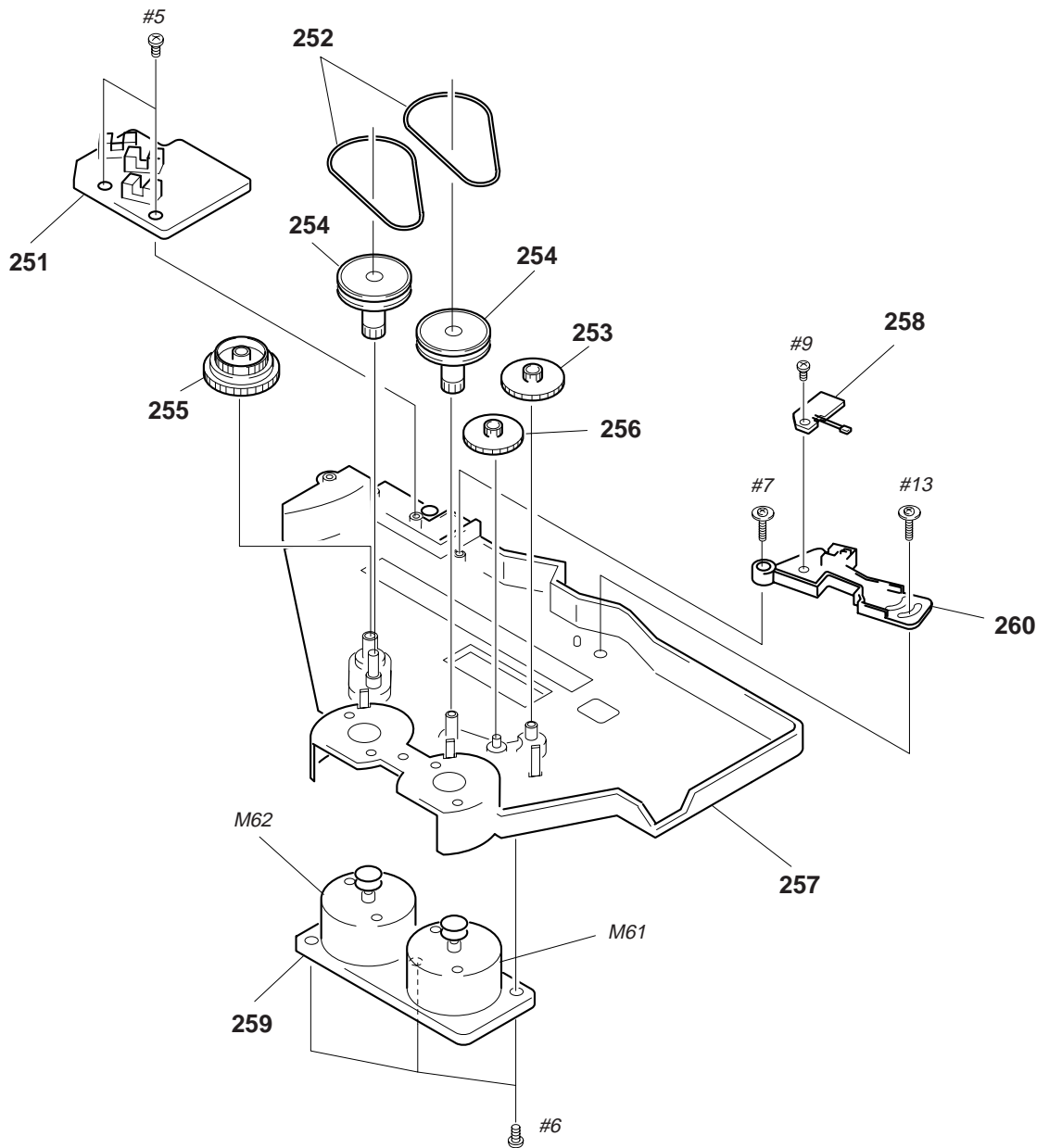

Ref. No.	Part No.	Description	Remark	Ref. No.	Part No.	Description	Remark
* 251	1-663-971-11	TABLE SENSOR BOARD		* 257	4-988-426-01	BASE (CDM)	
252	4-988-414-01	BELT		* 258	1-663-972-11	DISC SENSOR (R) BOARD	
253	4-988-423-01	GEAR (A) (LOADING)		* 259	1-663-974-11	MOTOR BOARD	
254	4-988-425-01	PULLEY		* 260	4-990-669-01	HOLDER (SENSOR)	
255	4-988-424-01	GEAR (TABLE)					
256	4-988-432-01	GEAR (B) (LOADING)		M61	X-4948-434-1	MOTOR ASSY (LOADING)	
				M62	X-4948-434-1	MOTOR ASSY (TABLE)	

8-6. OPTICAL PICK-UP SECTION (KSM-213 BFN/M-NP)

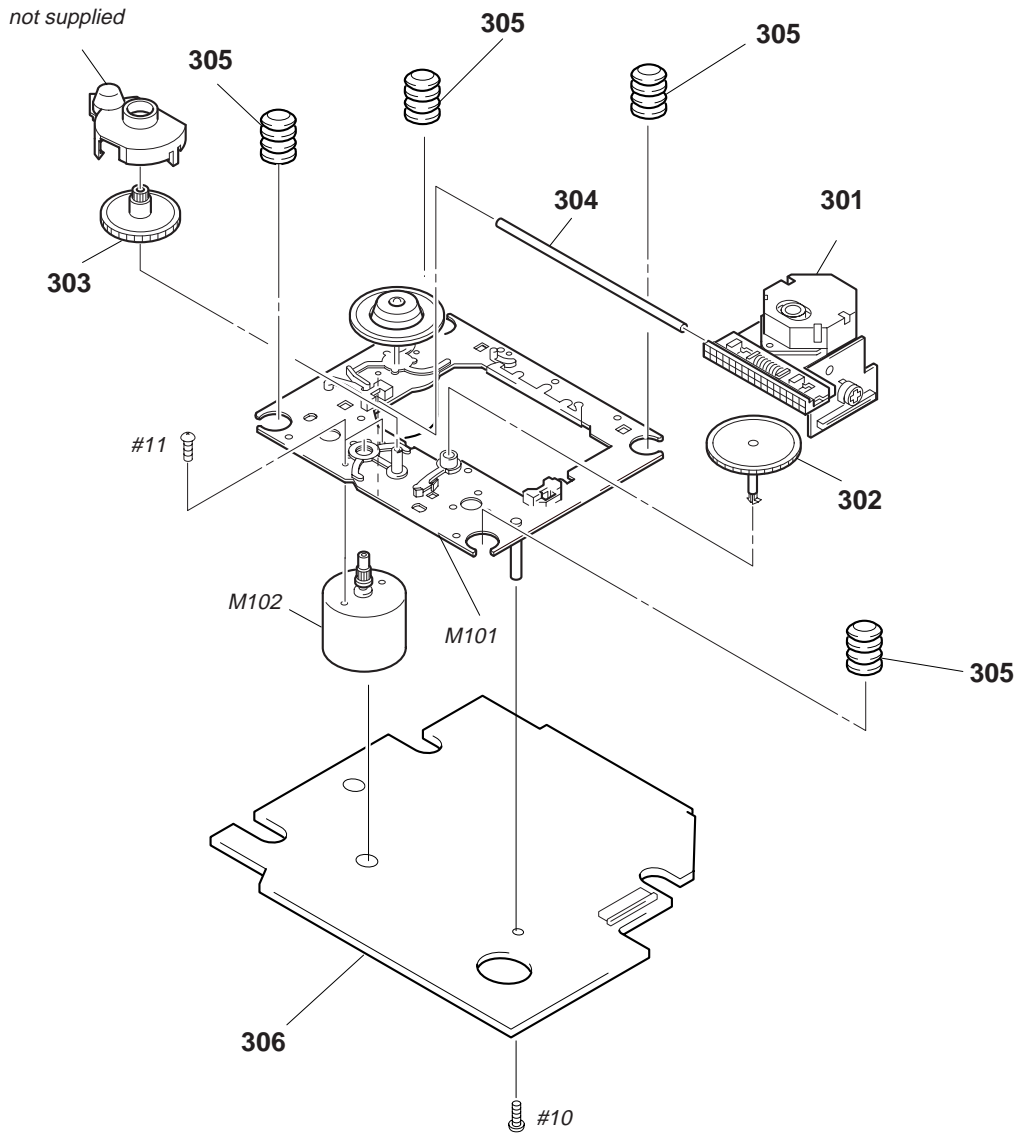

<p>The components identified by mark Δ or dotted line with mark Δ are critical for safety. Replace only with part number specified.</p>	<p>Les composants identifiés par une marque Δ sont critiques pour la sécurité. Ne les remplacer que par une pièce portant le numéro spécifié.</p>
---	---

Ref. No.	Part No.	Description	Remark	Ref. No.	Part No.	Description	Remark
Δ 301	8-848-379-31	OPTICAL PICK-UP KSS-213B/S-N		* 306	A-4699-675-A	BD BOARD, COMPLETE	
302	2-626-907-01	GEAR (A)(S)		M101	X-2646-110-2	T.T CHASSIS ASSY (MG)(F)(SPINDLE)	
303	2-627-003-02	GEAR (B)(RP)		M102	X-2625-769-1	MOTOR GEAR ASSY (MB)(RP)(SLED)	
304	2-626-908-01	SHAFT, SLED					
305	4-992-054-01	RUBBER, VIBRATION PROOF					

SECTION 9 ELECTRICAL PARTS LIST

AUDIO

Note:

The components identified by mark Δ or dotted line with mark Δ are critical for safety. Replace only with part number specified.

Les composants identifiés par une marque Δ sont critiques pour la sécurité. Ne les remplacer que par une pièce portant le numéro spécifié.

When indicating parts by reference number, please include the board name.

- Due to standardization, replacements in the parts list may be different from the parts specified in the diagrams or the components used on the set.
- -XX, -X mean standardized parts, so they may have some difference from the original one.
- Items marked "*" are not stocked since they are seldom required for routine service. Some delay should be anticipated when ordering these items.
- RESISTORS
All resistors are in ohms
METAL: Metal-film resistor
METAL OXIDE: Metal Oxide-film resistor
F : nonflammable

- SEMICONDUCTORS
In each case, u: μ , for example:
uA...: μ A..., uPA...: μ PA..., uPB...: μ PB...,
uPC...: μ PC..., uPD...: μ PD...
- CAPACITORS
uF : μ F
- COILS
uH : μ H
- Abbreviation
CND : Canadian model
SP : Singapore model
AUS : Australian model

Ref. No.	Part No.	Description	Remark	Ref. No.	Part No.	Description	Remark
*	A-4699-678-A	AUDIO BOARD, COMPLETE (US,CND) *****		D204	8-719-200-82	DIODE 11ES2	
				D205	8-719-200-82	DIODE 11ES2	
*	A-4699-681-A	AUDIO BOARD, COMPLETE (AEP,UK,SPAUS) *****		D701	8-719-987-63	DIODE 1N4148M	
				D801	8-719-987-63	DIODE 1N4148M	
				D802	8-719-987-63	DIODE 1N4148M	
*	A-4699-684-A	AUDIO BOARD, COMPLETE (E,PX) *****				< IC >	
		< CAPACITOR >		IC301	8-759-634-51	IC M5218AP	
C202	1-126-963-11	ELECT 4.7uF 20% 50V		IC302	8-759-634-51	IC M5218AP	
C203	1-161-494-00	CERAMIC 0.022uF 25V		IC401	8-759-634-51	IC M5218AP	
C206	1-124-122-11	ELECT 100uF 20% 50V		IC402	8-759-634-51	IC M5218AP	
C231	1-124-556-11	ELECT 2200uF 20% 16V		IC701	8-749-921-12	IC GP1F32T (DIGITAL OUT OPTICAL)	
C232	1-124-556-11	ELECT 2200uF 20% 16V				< JACK >	
C301	1-130-482-00	MYLAR 0.0082uF 5% 50V		J301	1-770-720-11	JACK, PIN 4P (2ND CD IN, LINE OUT)	
C302	1-106-343-00	MYLAR 1000PF 5% 200V		J701	1-774-726-11	JACK (S-LINK CONTROL-1)	
C303	1-126-967-11	ELECT 47uF 20% 10V				< COIL >	
C304	1-162-290-31	CERAMIC 470PF 10% 50V		L201	1-424-485-11	FILTER, LINE	
C305	1-124-282-00	ELECT 22uF 20% 25V				< TRANSISTOR >	
C331	1-126-965-11	ELECT 22uF 20% 50V		Q301	8-729-141-26	TRANSISTOR 2SC3622A-LK	
C401	1-130-482-00	MYLAR 0.0082uF 5% 50V		Q302	8-729-141-26	TRANSISTOR 2SC3622A-LK	
C402	1-106-343-00	MYLAR 1000PF 5% 200V		Q303	8-729-141-26	TRANSISTOR 2SC3622A-LK	
C403	1-126-967-11	ELECT 47uF 20% 10V		Q331	8-729-141-26	TRANSISTOR 2SC3622A-LK	
C404	1-162-290-31	CERAMIC 470PF 10% 50V		Q401	8-729-141-26	TRANSISTOR 2SC3622A-LK	
C405	1-124-282-00	ELECT 22uF 20% 25V		Q402	8-729-141-26	TRANSISTOR 2SC3622A-LK	
C431	1-126-965-11	ELECT 22uF 20% 50V		Q403	8-729-141-26	TRANSISTOR 2SC3622A-LK	
C701	1-126-933-11	ELECT 100uF 20% 10V		Q431	8-729-141-26	TRANSISTOR 2SC3622A-LK	
C702	1-161-494-00	CERAMIC 0.022uF 25V		Q701	8-729-230-45	TRANSISTOR 2SC2458-YGR	
C704	1-162-282-31	CERAMIC 100PF 10% 50V		Q802	8-729-900-80	TRANSISTOR DTC114ES	
C708	1-161-494-00	CERAMIC 0.022uF 25V		Q803	8-729-119-96	TRANSISTOR 2SA1175-HFE	
C801	1-126-964-11	ELECT 10uF 20% 50V				< RESISTOR >	
		< CONNECTOR >		R301	1-249-417-11	CARBON 1K 5% 1/4W F	
CN201	1-580-230-11	PIN, CONNECTOR (PC BOARD) 2P		R302	1-249-429-11	CARBON 10K 5% 1/4W	
* CN701	1-766-955-11	CONNECTOR, BOARD TO BOARD 11P		R303	1-249-432-11	CARBON 18K 5% 1/4W	
CN703	1-778-981-11	CONNECTOR, BOARD TO BOARD 13P		R304	1-247-836-11	CARBON 1.6K 5% 1/4W	
		< COMPOSITION CIRCUIT BLOCK >		R305	1-247-836-11	CARBON 1.6K 5% 1/4W	
CP2	1-537-771-21	TERMINAL BOARD, GROUND		R306	1-249-428-11	CARBON 8.2K 5% 1/4W F	
		< DIODE >		R307	1-247-826-00	CARBON 620 5% 1/4W	
D201	8-719-200-82	DIODE 11ES2		R308	1-249-429-11	CARBON 10K 5% 1/4W	
D202	8-719-200-82	DIODE 11ES2		R309	1-249-429-11	CARBON 10K 5% 1/4W	
D203	8-719-200-82	DIODE 11ES2		R310	1-249-429-11	CARBON 10K 5% 1/4W	

AUDIO

BD

Ref. No.	Part No.	Description	Remark
R311	1-247-887-00	CARBON 220K 5%	1/4W
R312	1-247-826-00	CARBON 620 5%	1/4W
R313	1-249-409-11	CARBON 220 5%	1/4W F
R314	1-249-421-11	CARBON 2.2K 5%	1/4W F
R315	1-249-393-11	CARBON 10 5%	1/4W F
R316	1-249-428-11	CARBON 8.2K 5%	1/4W F
R317	1-249-409-11	CARBON 220 5%	1/4W F
R318	1-247-895-00	CARBON 470K 5%	1/4W
R319	1-249-421-11	CARBON 2.2K 5%	1/4W F
R321	1-249-421-11	CARBON 2.2K 5%	1/4W F
R331	1-249-420-11	CARBON 1.8K 5%	1/4W F
R332	1-249-421-11	CARBON 2.2K 5%	1/4W F
R335	1-247-895-00	CARBON 470K 5%	1/4W
R401	1-249-417-11	CARBON 1K 5%	1/4W F
R402	1-249-429-11	CARBON 10K 5%	1/4W
R403	1-249-432-11	CARBON 18K 5%	1/4W
R404	1-247-836-11	CARBON 1.6K 5%	1/4W
R405	1-247-836-11	CARBON 1.6K 5%	1/4W
R406	1-249-428-11	CARBON 8.2K 5%	1/4W F
R407	1-247-826-00	CARBON 620 5%	1/4W
R408	1-249-429-11	CARBON 10K 5%	1/4W
R409	1-249-429-11	CARBON 10K 5%	1/4W
R410	1-249-429-11	CARBON 10K 5%	1/4W
R411	1-247-887-00	CARBON 220K 5%	1/4W
R412	1-247-826-00	CARBON 620 5%	1/4W
R413	1-249-409-11	CARBON 220 5%	1/4W F
R414	1-249-421-11	CARBON 2.2K 5%	1/4W F
R415	1-249-393-11	CARBON 10 5%	1/4W F
R416	1-249-428-11	CARBON 8.2K 5%	1/4W F
R417	1-249-409-11	CARBON 220 5%	1/4W F
R418	1-247-895-00	CARBON 470K 5%	1/4W
R419	1-249-421-11	CARBON 2.2K 5%	1/4W F
R421	1-249-421-11	CARBON 2.2K 5%	1/4W F
R431	1-249-420-11	CARBON 1.8K 5%	1/4W F
R432	1-249-421-11	CARBON 2.2K 5%	1/4W F
R435	1-247-895-00	CARBON 470K 5%	1/4W
R701	1-249-429-11	CARBON 10K 5%	1/4W
R702	1-249-425-11	CARBON 4.7K 5%	1/4W F
R703	1-249-429-11	CARBON 10K 5%	1/4W
R704	1-249-393-11	CARBON 10 5%	1/4W F
R801	1-249-437-11	CARBON 47K 5%	1/4W
R802	1-249-425-11	CARBON 4.7K 5%	1/4W
R803	1-249-425-11	CARBON 4.7K 5%	1/4W
< SWITCH >			
S201	1-572-675-11	SWITCH, POWER VOLTAGE CHANGE (VOLTAGE SELECTOR)(E,PX)	
S701	1-571-308-11	SWITCH, SLIDE (COMMAND MODE CD)	
< TRANSFORMER >			
△ T501	1-431-333-11	TRANSFORMER, POWER (US,CND)	
△ T501	1-431-334-11	TRANSFORMER, POWER (AEP,UK,SPAUS)	
△ T501	1-431-335-11	TRANSFORMER, POWER (E,PX)	

Ref. No.	Part No.	Description	Remark
*	A-4699-675-A	BD BOARD, COMPLETE	

< CAPACITOR >			
C101	1-163-038-91	CERAMIC CHIP 0.1uF	25V
C102	1-163-038-91	CERAMIC CHIP 0.1uF	25V
C103	1-164-489-11	CERAMIC CHIP 0.22uF	10% 16V
C104	1-163-003-11	CERAMIC CHIP 330PF	10% 50V
C105	1-163-023-00	CERAMIC CHIP 0.015uF	5% 50V
C106	1-110-501-11	CERAMIC CHIP 0.33uF	10% 16V
C107	1-163-989-11	CERAMIC CHIP 0.033uF	10% 25V
C108	1-164-492-11	CERAMIC CHIP 0.15uF	10% 16V
C109	1-164-161-11	CERAMIC CHIP 0.0022uF	10% 100V
C110	1-163-037-11	CERAMIC CHIP 0.022uF	10% 50V
C111	1-163-989-11	CERAMIC CHIP 0.033uF	10% 25V
C112	1-163-009-11	CERAMIC CHIP 0.001uF	10% 50V
C113	1-164-492-11	CERAMIC CHIP 0.15uF	10% 16V
C114	1-164-492-11	CERAMIC CHIP 0.15uF	10% 16V
C115	1-164-232-11	CERAMIC CHIP 0.01uF	50V
C116	1-164-232-11	CERAMIC CHIP 0.01uF	50V
C117	1-163-001-11	CERAMIC CHIP 220PF	10% 50V
C118	1-107-823-11	CERAMIC CHIP 0.47uF	10% 16V
C119	1-164-489-11	CERAMIC CHIP 0.22uF	10% 16V
C120	1-124-234-00	ELECT 22uF	20% 16V
C121	1-164-182-11	CERAMIC CHIP 0.0033uF	10% 50V
C122	1-126-963-11	ELECT 4.7uF	20% 50V
C123	1-163-038-91	CERAMIC CHIP 0.1uF	25V
C124	1-104-396-11	ELECT 10uF	20% 16V
C125	1-126-177-11	ELECT 100uF	20% 10V
C126	1-126-177-11	ELECT 100uF	20% 10V
C127	1-163-989-11	CERAMIC CHIP 0.033uF	10% 25V
C128	1-163-809-11	CERAMIC CHIP 0.047uF	10% 25V
C129	1-110-501-11	CERAMIC CHIP 0.33uF	10% 16V
C130	1-124-443-00	ELECT 100uF	20% 10V
C131	1-163-009-11	CERAMIC CHIP 0.001uF	10% 50V
C132	1-163-038-91	CERAMIC CHIP 0.1uF	25V
C133	1-163-038-91	CERAMIC CHIP 0.1uF	25V
C141	1-163-038-91	CERAMIC CHIP 0.1uF	25V
C142	1-164-505-91	CERAMIC CHIP 2.2uF	16V
C151	1-107-725-11	CERAMIC CHIP 0.1uF	10% 16V
C152	1-107-725-11	CERAMIC CHIP 0.1uF	10% 16V
C153	1-107-725-11	CERAMIC CHIP 0.1uF	10% 16V
C154	1-163-009-11	CERAMIC CHIP 0.001uF	10% 50V
C155	1-163-093-00	CERAMIC CHIP 10PF	5% 50V
C156	1-163-085-00	CERAMIC CHIP 2PF	50V
C157	1-164-232-11	CERAMIC CHIP 0.01uF	50V
C158	1-163-038-91	CERAMIC CHIP 0.1uF	25V
C159	1-163-101-00	CERAMIC CHIP 22PF	5% 50V
C160	1-163-117-00	CERAMIC CHIP 100PF	5% 50V
C161	1-163-038-91	CERAMIC CHIP 0.1uF	25V
C162	1-163-038-91	CERAMIC CHIP 0.1uF	25V
C163	1-163-038-91	CERAMIC CHIP 0.1uF	25V
C164	1-163-227-11	CERAMIC CHIP 10PF	0.5PF 50V
C165	1-163-227-11	CERAMIC CHIP 10PF	0.5PF 50V
C166	1-124-443-00	ELECT 100uF	20% 10V
C167	1-163-038-91	CERAMIC CHIP 0.1uF	25V
C171	1-163-038-91	CERAMIC CHIP 0.1uF	25V

The components identified by mark △ or dotted line with mark △ are critical for safety. Replace only with part number specified.	Les composants identifiés par une marque △ sont critiques pour la sécurité. Ne les remplacer que par une pièce portant le numéro spécifié.
--	--

Ref. No.	Part No.	Description	Remark	Ref. No.	Part No.	Description	Remark
C172	1-126-177-11	ELECT	100uF 20% 10V	R114	1-216-055-00	METAL GLAZE	1.8K 5% 1/10W
C173	1-124-589-11	ELECT	47uF 20% 16V	R115	1-216-689-11	METAL CHIP	39K 5% 1/10W
C174	1-163-038-91	CERAMIC CHIP	0.1uF 25V	R116	1-216-057-00	METAL CHIP	2.2K 5% 1/10W
C175	1-163-038-91	CERAMIC CHIP	0.1uF 25V	R117	1-216-085-00	METAL CHIP	33K 5% 1/10W
C181	1-104-664-11	ELECT	47uF 20% 16V	R118	1-216-081-00	METAL CHIP	22K 5% 1/10W
C182	1-104-664-11	ELECT	47uF 20% 16V	R119	1-216-069-00	METAL CHIP	6.8K 5% 1/10W
C183	1-163-003-11	CERAMIC CHIP	330PF 10% 50V	R120	1-216-085-00	METAL CHIP	33K 5% 1/10W
C184	1-163-003-11	CERAMIC CHIP	330PF 10% 50V	R121	1-216-059-00	METAL CHIP	2.7K 5% 1/10W
		< CONNECTOR >		R122	1-216-083-00	METAL CHIP	27K 5% 1/10W
CN101	1-770-173-11	CONNECTOR, FFC/FPC 16P		R123	1-216-099-00	METAL CHIP	120K 5% 1/10W
CN102	1-691-894-21	SOCKET, CONNECTOR 16P		R124	1-216-093-00	METAL CHIP	68K 5% 1/10W
* CN103	1-568-852-11	SOCKET, CONNECTOR 9P		R125	1-216-089-91	METAL GLAZE	47K 5% 1/10W
		< DIODE >		R126	1-216-037-00	METAL CHIP	330 5% 1/10W
D151	8-719-987-63	DIODE 1N4148M		R127	1-216-089-91	METAL GLAZE	47K 5% 1/10W
		< IC >		R128	1-216-077-00	METAL CHIP	15K 5% 1/10W
IC101	8-759-449-64	IC LA9240M		R129	1-216-069-00	METAL CHIP	6.8K 5% 1/10W
IC102	8-759-449-65	IC LC78622E		R130	1-216-113-00	METAL CHIP	470K 5% 1/10W
IC103	8-759-449-66	IC LA6541		R131	1-216-113-00	METAL CHIP	470K 5% 1/10W
IC104	8-759-428-57	IC LC89170M		R132	1-216-065-00	METAL CHIP	4.7K 5% 1/10W
		< JUMPER RESISTOR >		R133	1-216-113-00	METAL CHIP	470K 5% 1/10W
JW1	1-216-295-91	CONDUCTOR, CHIP (2012)		R134	1-216-113-00	METAL CHIP	470K 5% 1/10W
JW2	1-216-295-91	CONDUCTOR, CHIP (2012)		R135	1-216-065-00	METAL CHIP	4.7K 5% 1/10W
JW4	1-216-295-91	CONDUCTOR, CHIP (2012)		R136	1-216-073-00	METAL CHIP	10K 5% 1/10W
JW5	1-216-295-91	CONDUCTOR, CHIP (2012)		R137	1-216-009-00	METAL CHIP	22 5% 1/10W
JW6	1-216-295-91	CONDUCTOR, CHIP (2012)		R138	1-249-437-11	CARBON	47K 5% 1/4W
JW7	1-216-295-91	CONDUCTOR, CHIP (2012)					(SUFFIX No-11)
JW8	1-216-295-91	CONDUCTOR, CHIP (2012)		R138	1-216-089-91	MATAL GLAZE	47K 5% 1/10W
JW9	1-216-295-91	CONDUCTOR, CHIP (2012)					(SUFFIX No-12)
JW10	1-216-295-91	CONDUCTOR, CHIP (2012)		R151	1-216-045-00	METAL CHIP	680 5% 1/10W
		< MOTOR >		R152	1-216-093-00	METAL CHIP	68K 5% 1/10W
M101	X-2646-110-2	T.T CHASSIS ASSY (MG)(F)(SPINDLE)		R153	1-216-051-00	METAL CHIP	1.2K 5% 1/10W
M102	X-2625-769-1	MOTOR GEAR ASSY (MB)(RP)(SLED)		R154	1-216-085-00	METAL CHIP	33K 5% 1/10W
		< TRANSISTOR >		R155	1-216-089-91	METAL GLAZE	47K 5% 1/10W
Q101	8-729-119-78	TRANSISTOR 2SC403SP-51		R156	1-216-081-00	METAL CHIP	22K 5% 1/10W
Q102	8-729-119-78	TRANSISTOR 2SC403SP-51		R157	1-216-077-00	METAL CHIP	15K 5% 1/10W
Q103	8-729-119-76	TRANSISTOR 2SA1175-HFE		R158	1-216-049-91	METAL GLAZE	1K 5% 1/10W
		< RESISTOR >		R159	1-216-083-00	METAL CHIP	27K 5% 1/10W
R101	1-216-097-91	METAL GLAZE	100K 5% 1/10W	R160	1-216-037-00	METAL CHIP	330 5% 1/10W
R102	1-216-093-00	METAL CHIP	68K 5% 1/10W	R161	1-216-073-00	METAL CHIP	10K 5% 1/10W
R103	1-216-093-00	METAL CHIP	68K 5% 1/10W	R162	1-216-037-00	METAL CHIP	330 5% 1/10W
R104	1-216-093-00	METAL CHIP	68K 5% 1/10W	R163	1-216-049-91	METAL GLAZE	1K 5% 1/10W
R105	1-216-093-00	METAL CHIP	68K 5% 1/10W	R164	1-216-065-00	METAL CHIP	4.7K 5% 1/10W
R106	1-216-097-91	METAL GLAZE	100K 5% 1/10W	R165	1-216-025-91	METAL GLAZE	100 5% 1/10W
R107	1-216-097-91	METAL GLAZE	100K 5% 1/10W	R166	1-216-025-91	METAL GLAZE	100 5% 1/10W
R108	1-216-068-00	METAL CHIP	6.2K 5% 1/10W	R171	1-216-025-91	METAL GLAZE	100 5% 1/10W
R109	1-216-076-00	METAL CHIP	13K 5% 1/10W	R172	1-216-025-91	METAL GLAZE	100 5% 1/10W
R110	1-216-093-00	METAL CHIP	68K 5% 1/10W	R173	1-216-025-91	METAL GLAZE	100 5% 1/10W
R111	1-216-057-00	METAL CHIP	2.2K 5% 1/10W	R174	1-216-025-91	METAL GLAZE	100 5% 1/10W
R112	1-216-109-00	METAL CHIP	330K 5% 1/10W	R181	1-216-057-00	METAL CHIP	2.2K 5% 1/10W
R113	1-216-099-00	METAL GLAZE	120K 5% 1/10W	R182	1-216-057-00	METAL CHIP	2.2K 5% 1/10W
				R183	1-216-073-00	METAL CHIP	10K 5% 1/10W
				R184	1-216-073-00	METAL CHIP	10K 5% 1/10W
				R191	1-216-025-91	METAL GLAZE	100 5% 1/10W
				R192	1-216-041-00	METAL CHIP	470 5% 1/10W
				R193	1-216-041-00	METAL CHIP	470 5% 1/10W
				R194	1-216-025-91	METAL GLAZE	100 5% 1/10W
				R195	1-216-041-00	METAL CHIP	470 5% 1/10W

BD**DISC SENSOR (R)****DISC SENSOR (S)****DISPLAY**

Ref. No.	Part No.	Description	Remark
R196	1-216-025-91	METAL GLAZE 100	5% 1/10W
R197	1-216-025-91	METAL GLAZE 100	5% 1/10W
< SWITCH >			
S101	1-572-085-11	SWITCH, LEAF (LIMIT)	
< VIBRATOR >			
X101	1-577-576-21	VIBRATOR, CRYSTAL (16.9344MHz)	

*	1-663-972-11	DISC SENSOR (R) BOARD *****	
*	4-990-669-01	HOLDER (SENSOR)	
< TRANSISTOR >			
Q51	8-729-926-31	PHOTO TRANSISTOR PT483F1S	

*	1-663-973-11	DISC SENSOR (S) BOARD *****	
*	4-976-473-01	HOLDER (LED-S)	
< CONNECTOR >			
* CN53	1-568-951-11	PIN, CONNECTOR 2P	
< DIODE >			
D51	8-719-055-84	DIODE GL-528VS1 (DISC SENSOR)	
< RESISTOR >			
R54	1-249-409-11	CARBON 220	5% 1/4W F

*	A-4699-676-A	DISPLAY BOARD, COMPLETE *****	
*	4-987-942-01	HOLDER, FL TUBE	
< CAPACITOR >			
C901	1-164-159-11	CERAMIC 0.1uF	50V
C902	1-162-215-31	CERAMIC 47PF	5% 50V
C903	1-161-494-00	CERAMIC 0.022uF	25V
C904	1-126-933-11	ELECT 100uF	20% 10V
< CONNECTOR >			
CN901	1-568-838-11	SOCKET, CONNECTOR 21P	
* CN903	1-568-943-11	PIN, CONNECTOR 5P	
< DIODE >			
D901	8-719-018-46	DIODE SEL3510C-CD (▷)	
D902	8-719-313-50	DIODE SEL6810A-TH12 (■)	
D905	8-719-313-50	DIODE SEL6810A-TH12 (PLUS ONE)	
< FLUORESCENT INDICATOR >			
FL901	1-517-678-11	INDICATOR TUBE, FLUORESCENT	

Ref. No.	Part No.	Description	Remark
< IC >			
IC802	8-759-459-84	IC NJL56H400	
IC901	8-759-451-97	IC MSM9202-03GS-BK	
< TRANSISTOR >			
Q901	8-729-029-56	TRANSISTOR DTA144ESA	
Q902	8-729-119-96	TRANSISTOR 2SA1175-HFE	
Q903	8-729-119-96	TRANSISTOR 2SA1175-HFE	
Q904	8-729-119-96	TRANSISTOR 2SA1175-HFE	
< RESISTOR >			
R901	1-249-415-11	CARBON 680	5% 1/4W F
R902	1-249-417-11	CARBON 1K	5% 1/4W F
R903	1-249-419-11	CARBON 1.5K	5% 1/4W F
R904	1-249-421-11	CARBON 2.2K	5% 1/4W F
R905	1-247-843-11	CARBON 3.3K	5% 1/4W
R906	1-249-427-11	CARBON 6.8K	5% 1/4W F
R907	1-249-431-11	CARBON 15K	5% 1/4W
R909	1-249-415-11	CARBON 680	5% 1/4W F
R910	1-249-417-11	CARBON 1K	5% 1/4W F
R911	1-249-419-11	CARBON 1.5K	5% 1/4W F
R912	1-249-421-11	CARBON 2.2K	5% 1/4W F
R913	1-247-843-11	CARBON 3.3K	5% 1/4W
R914	1-249-427-11	CARBON 6.8K	5% 1/4W F
R915	1-249-431-11	CARBON 15K	5% 1/4W
R930	1-247-843-11	CARBON 3.3K	5% 1/4W
R931	1-249-417-11	CARBON 1K	5% 1/4W F
R932	1-249-417-11	CARBON 1K	5% 1/4W F
R933	1-249-417-11	CARBON 1K	5% 1/4W F
R934	1-249-417-11	CARBON 1K	5% 1/4W F
R935	1-249-429-11	CARBON 10K	5% 1/4W
R936	1-249-441-11	CARBON 100K	5% 1/4W
R937	1-247-807-31	CARBON 100	5% 1/4W
R938	1-247-807-31	CARBON 100	5% 1/4W
R941	1-249-409-11	CARBON 220	5% 1/4W F
R942	1-249-407-11	CARBON 150	5% 1/4W F
R946	1-249-409-11	CARBON 220	5% 1/4W F
R949	1-249-429-11	CARBON 10K	5% 1/4W
R950	1-249-429-11	CARBON 10K	5% 1/4W
R951	1-249-429-11	CARBON 10K	5% 1/4W
R952	1-249-429-11	CARBON 10K	5% 1/4W
R953	1-249-429-11	CARBON 10K	5% 1/4W
R954	1-249-429-11	CARBON 10K	5% 1/4W
< ROTARY ENCODER >			
RE901	1-473-957-11	ENCODER, ROTARY (DISC/CHARACTER)	
< SWITCH >			
S901	1-554-303-21	SWITCH, TACTILE (▷▷)	
S902	1-554-303-21	SWITCH, TACTILE (◁◁)	
S903	1-554-303-21	SWITCH, TACTILE (■)	
S904	1-554-303-21	SWITCH, TACTILE (■■)	
S905	1-554-303-21	SWITCH, TACTILE (▷)	
S906	1-554-303-21	SWITCH, TACTILE (PLUS ONE)	
S907	1-554-303-21	SWITCH, TACTILE (CONTINUE)	
S908	1-554-303-21	SWITCH, TACTILE (SHUFFLE)	

DISPLAY

LED

MAIN

Ref. No.	Part No.	Description	Remark
S909	1-554-303-21	SWITCH, TACTILE (CLEAR)	
S910	1-554-303-21	SWITCH, TACTILE (CHECK)	
S911	1-554-303-21	SWITCH, TACTILE (REPEAT)	
S912	1-554-303-21	SWITCH, TACTILE (PROGRAM)	
S913	1-554-303-21	SWITCH, TACTILE (SEARCH)	
S914	1-554-303-21	SWITCH, TACTILE (INPUT)	
S915	1-554-303-21	SWITCH, TACTILE (TIME/TEXT)	
S920	1-762-936-11	SWITCH, LEVER (PUSH OPEN)	

*	1-665-903-11	LED BOARD *****	
		< CONNECTOR >	
CNP841	1-506-481-11	PIN, CONNECTOR 2P	
		< DIODE >	
D841	8-719-057-10	DIODE LNJ301MPUJAB	
D842	8-719-057-09	DIODE LNJ801LPDJA	
D843	8-719-064-21	DIODE LNJ801TPSJA	
		< RESISTOR >	
R841	1-249-407-11	CARBON 150 5% 1/4W F	
R842	1-249-410-11	CARBON 270 5% 1/4W F	
R843	1-249-408-11	CARBON 180 5% 1/4W F	

*	A-4699-679-A	MAIN BOARD, COMPLETE (US,CND) *****	
*	A-4699-682-A	MAIN BOARD, COMPLETE (AEP,UK,SP,AUS) *****	
*	A-4699-683-A	MAIN BOARD, COMPLETE (E,PX) *****	
		< CAPACITOR >	
C204	1-124-556-11	ELECT 2200uF 20% 16V	
C205	1-124-556-11	ELECT 2200uF 20% 16V	
C207	1-126-965-11	ELECT 22uF 20% 50V	
C208	1-126-963-11	ELECT 4.7uF 20% 50V	
C209	1-126-963-11	ELECT 4.7uF 20% 50V	
C210	1-126-935-11	ELECT 470uF 20% 6.3V	
C211	1-126-927-11	ELECT 2200uF 20% 10V	
C212	1-126-941-11	ELECT 470uF 20% 16V	
C220	1-126-963-11	ELECT 4.7uF 20% 50V	
C221	1-126-935-11	ELECT 470uF 20% 6.3V	
C222	1-126-963-11	ELECT 4.7uF 20% 50V	
C250	1-126-962-11	ELECT 3.3uF 20% 50V	
C382	1-126-962-11	ELECT 3.3uF 20% 50V	
C501	1-161-494-00	CERAMIC 0.022uF 25V	
C502	1-161-494-00	CERAMIC 0.022uF 25V	
C503	1-126-933-11	ELECT 100uF 20% 10V	
C504	1-162-306-11	CERAMIC 0.01uF 20% 16V	
C505	1-162-306-11	CERAMIC 0.01uF 20% 16V	
C506	1-162-306-11	CERAMIC 0.01uF 20% 16V	
C507	1-162-294-31	CERAMIC 0.001uF 10% 50V	

Ref. No.	Part No.	Description	Remark
C530	1-110-489-11	CAPACITOR 1F	5.5V
C531	1-164-159-11	CERAMIC 0.1uF	50V
		< CONNECTOR >	
* CN501	1-568-835-11	SOCKET, CONNECTOR 16P	
* CN502	1-568-828-11	SOCKET, CONNECTOR 9P	
CN503	1-568-838-11	SOCKET, CONNECTOR 21P	
CN601	1-506-468-11	PIN, CONNECTOR 3P	
* CN603	1-568-955-11	PIN, CONNECTOR 6P	
* CN702	1-770-730-11	CONNECTOR, BOARD TO BOARD 11P	
CN704	1-778-982-11	CONNECTOR, BOARD TO BOARD 13P	
CN801	1-506-468-11	PIN, CONNECTOR 3P	
		< DIODE >	
D206	8-719-109-93	DIODE RD6.2ESB2	
D207	8-719-113-90	DIODE RD30ES-T2B4	
D210	8-719-987-63	DIODE 1N4148M	
D211	8-719-921-42	DIODE MTZJ-5.1A	
D212	8-719-987-63	DIODE 1N4148M	
D304	8-719-987-63	DIODE 1N4148M	
D382	8-719-987-63	DIODE 1N4148M	
D404	8-719-987-63	DIODE 1N4148M	
D501	8-719-987-63	DIODE 1N4148M	
		< FERRITE BEAD >	
FB503	1-412-473-21	INDUCTOR 0UH	
		< IC >	
IC201	8-759-061-65	IC LA5602	
IC202	8-749-011-78	IC BA17807T	
IC203	8-759-821-93	IC LA5601	
IC501	8-752-884-76	IC CXP84340-051Q	
IC502	8-759-463-99	IC M5M5256DFP-70XL	
IC601	8-759-356-03	IC BA6780	
		< COIL >	
L502	1-410-507-11	INDUCTOR 6.8uH	
		< TRANSISTOR >	
Q201	8-729-140-97	TRANSISTOR 2SB734-34	
Q202	8-729-119-76	TRANSISTOR 2SA1175-HFE	
Q304	8-729-029-56	TRANSISTOR DTA144ESA	
Q305	8-729-029-67	TRANSISTOR DTC114ESA-TP	
Q380	8-729-029-56	TRANSISTOR DTA144ESA	
Q381	8-729-029-56	TRANSISTOR DTA144ESA	
Q382	8-729-029-56	TRANSISTOR DTA144ESA	
Q383	8-729-029-56	TRANSISTOR DTA144ESA	
Q404	8-729-029-56	TRANSISTOR DTA144ESA	
Q405	8-729-029-67	TRANSISTOR DTC114ESA-TP	
Q481	8-729-029-56	TRANSISTOR DTA144ESA	
Q501	8-729-029-67	TRANSISTOR DTC114ESA-TP	
Q502	8-729-029-67	TRANSISTOR DTC114ESA-TP	
Q503	8-729-029-67	TRANSISTOR DTC114ESA-TP	

MAIN	MOTOR	POWER SW	SW
-------------	--------------	-----------------	-----------

Ref. No.	Part No.	Description				Remark	
< RESISTOR >							
R201	1-249-435-11	CARBON	33K	5%	1/4W		
R202	1-249-425-11	CARBON	4.7K	5%	1/4W	F	
R203	1-249-429-11	CARBON	10K	5%	1/4W		
R204	1-249-438-11	CARBON	56K	5%	1/4W		
R210	1-249-411-11	CARBON	330	5%	1/4W		
R320	1-249-441-11	CARBON	100K	5%	1/4W		
R329	1-249-441-11	CARBON	100K	5%	1/4W		
R330	1-249-441-11	CARBON	100K	5%	1/4W		
R333	1-249-441-11	CARBON	100K	5%	1/4W		
R334	1-249-441-11	CARBON	100K	5%	1/4W		
R420	1-249-441-11	CARBON	100K	5%	1/4W		
R430	1-249-441-11	CARBON	100K	5%	1/4W		
R501	1-249-429-11	CARBON	10K	5%	1/4W		
R502	1-249-429-11	CARBON	10K	5%	1/4W		
R503	1-249-429-11	CARBON	10K	5%	1/4W		
R504	1-249-429-11	CARBON	10K	5%	1/4W		
R505	1-249-429-11	CARBON	10K	5%	1/4W		
R506	1-249-427-11	CARBON	6.8K	5%	1/4W	F	
R507	1-249-427-11	CARBON	6.8K	5%	1/4W	F	
R508	1-249-427-11	CARBON	6.8K	5%	1/4W	F	
R509	1-249-429-11	CARBON	10K	5%	1/4W		
R510	1-249-429-11	CARBON	10K	5%	1/4W		
R511	1-249-429-11	CARBON	10K	5%	1/4W		
R512	1-249-429-11	CARBON	10K	5%	1/4W		
R513	1-249-429-11	CARBON	10K	5%	1/4W		
R514	1-249-429-11	CARBON	10K	5%	1/4W		
R515	1-249-429-11	CARBON	10K	5%	1/4W		
R516	1-249-429-11	CARBON	10K	5%	1/4W		
R517	1-249-437-11	CARBON	47K	5%	1/4W		
R519	1-249-429-11	CARBON	10K	5%	1/4W		
R520	1-249-429-11	CARBON	10K	5%	1/4W		
R530	1-249-429-11	CARBON	10K	5%	1/4W		
R531	1-249-429-11	CARBON	10K	5%	1/4W		
R532	1-249-403-11	CARBON	68	5%	1/4W	F	
R533	1-249-403-11	CARBON	68	5%	1/4W	F	
R601	1-249-429-11	CARBON	10K	5%	1/4W		
R602	1-249-428-11	CARBON	8.2K	5%	1/4W	F	
R603	1-249-382-11	CARBON	1.2	5%	1/6W	F	
R604	1-249-382-11	CARBON	1.2	5%	1/6W	F	
R605	1-247-850-11	CARBON	6.2K	5%	1/4W		
R606	1-249-429-11	CARBON	10K	5%	1/4W		
R607	1-247-807-31	CARBON	100	5%	1/4W		
< VARIABLE RESISTOR >							
RV601	1-238-551-11	RES, ADJ, CARBON 220K					
< TEST PIN >							
TP501	1-564-506-11	PLUG, CONNECTOR 3P					
< VIBRATOR >							
X501	1-579-175-11	VIBRATOR, CERAMIC (10MHz)					

Ref. No.	Part No.	Description				Remark
*	1-663-974-11	MOTOR BOARD				

< CONNECTOR >						
CN61	1-506-469-11	PIN, CONNECTOR 4P				
< MOTOR >						
M61	X-4948-431-1	MOTOR ASSY (LOADING)				
M62	X-4948-431-1	MOTOR ASSY (TABLE)				

*	1-665-901-11	POWER SW BOARD				

< DIODE >						
D903	8-719-057-09	DIODE LNJ801LPDJA (POWER)				
D904	8-719-057-97	DIODE SEL5923A-TP15 (MEGA CONTROL)				
D945	8-719-057-97	DIODE SEL5923A-TP15 (MEGA CONTROL)				
< TRANSISTOR >						
Q905	8-729-900-61	TRANSISTOR DTA144ES				
Q906	8-729-119-96	TRANSISTOR 2SA1175-HFE				
< RESISTOR >						
R916	1-249-415-11	CARBON	680	5%	1/4W	F
R917	1-249-417-11	CARBON	1K	5%	1/4W	F
R918	1-249-419-11	CARBON	1.5K	5%	1/4W	F
R943	1-249-407-11	CARBON	150	5%	1/4W	F
R944	1-249-407-11	CARBON	150	5%	1/4W	F
R945	1-249-407-11	CARBON	150	5%	1/4W	F
R947	1-249-429-11	CARBON	10K	5%	1/4W	
R948	1-249-429-11	CARBON	10K	5%	1/4W	
< SWITCH >						
S916	1-554-303-21	SWITCH, TACTILE (POWER)				
S917	1-554-303-21	SWITCH, TACTILE (X-FADE)				
S918	1-554-303-21	SWITCH, TACTILE (NO DELAY)				
S919	1-554-303-21	SWITCH, TACTILE (MEGA CONTROL)				

*	1-663-975-11	SW BOARD				

< CONNECTOR >						
* CN54	1-568-941-11	PIN, CONNECTOR 3P				
< SWITCH >						
S51	1-571-958-11	SWITCH, PUSH (1 KEY)(UP)				
S52	1-571-958-11	SWITCH, PUSH (1 KEY)(DOWN)				

TABLE SENSOR

Ref. No.	Part No.	Description	Remark
*	1-663-971-11	TABLE SENSOR BOARD *****	
	7-685-132-19	SCREW +BTP 2.6X5 TYPE2 N-S < CONNECTOR >	
* CN51	1-568-944-11	PIN, CONNECTOR 6P	
CN52	1-506-481-11	PIN, CONNECTOR 2P < IC >	
IC51	8-749-924-18	IC PHOTO INTERRUPTER RPI-1391	
IC52	8-749-924-18	IC PHOTO INTERRUPTER RPI-1391	
IC53	8-749-924-18	IC PHOTO INTERRUPTER RPI-1391 < RESISTOR >	
R51	1-249-416-11	CARBON 820 5% 1/4W F	
R52	1-249-416-11	CARBON 820 5% 1/4W F	
R53	1-249-416-11	CARBON 820 5% 1/4W F	

MISCELLANEOUS *****			
△ 9	1-558-943-41	CORD, POWER (E,PX)	
△ 9	1-575-651-21	CORD, POWER (AEP,SP)	
△ 9	1-590-926-11	CORD, POWER (US,CND)	
△ 9	1-696-845-11	CORD, POWER (AUS)	
△ 9	1-751-529-11	CORD, POWER (UK)	
△ 10	1-569-007-11	ADAPTOR, CONVERSION 2P (E,PX)	
64	1-773-174-11	WIRE (FLAT TYPE) (21 CORE)	
111	1-782-465-11	WIRE (FLAT TYPE) (16 CORE)(300mm)	
112	1-769-921-11	WIRE (FLAT TYPE) (9 CORE)	
224	1-777-874-11	WIRE (FLAT TYPE) (16 CORE)(75mm)	
△ 301	8-848-379-31	OPTICAL PICK-UP KSS-213B/S-N	
FL901	1-517-678-11	INDICATOR TUBE, FLUORESCENT	
M61	X-4948-434-1	MOTOR ASSY (LOADING)	
M62	X-4948-434-1	MOTOR ASSY (TABLE)	
M101	X-2646-110-2	T.T CHASSIS ASSY (MG)(F)(SPINDLE)	
M102	X-2625-769-1	MOTOR GEAR ASSY (MB)(RP)(SLED)	
△ T501	1-431-333-11	TRANSFORMER, POWER (US,CND)	
△ T501	1-431-334-11	TRANSFORMER, POWER (AEP,UK,SP,AUS)	
△ T501	1-431-335-11	TRANSFORMER, POWER (E,PX)	

Ref. No.	Part No.	Description	Remark
		ACCESSORIES & PACKING MATERIALS *****	
	1-475-208-11	REMOTE COMMANDER (RM-DX55)	
	1-558-271-11	CORD, CONNECTION (AUDIO 108cm)	
	3-810-765-32	MANUAL,COMMONNESS INSTRUCTION (FOR CONTROL-A1)(ENGLISH)(US,UK,AUS,PX)	
	3-810-765-42	MANUAL,COMMONNESS INSTRUCTION (FOR CONTROL-A1)(ENGLISH,FRENCH,GERMAN,SPANISH, DUTCH,SWEDISH,ITALIAN,PORTUGUESE,CHINESE) (CND,AEP,E,SP)	
	3-859-801-11	MANUAL, INSTRUCTION (ENGLISH)	
	3-859-801-21	MANUAL, INSTRUCTION (FRENCH,SPANISH,PORTUGUESE)(CND,AEP,E)	
	3-859-801-31	MANUAL, INSTRUCTION (GERMAN,DUTCH,ITALIAN)(AEP)	
	3-859-801-41	MANUAL, INSTRUCTION (SWEDISH,DANISH,FINNISH)(AEP)	
	3-859-801-51	MANUAL, INSTRUCTION (CHINESE)(SP)	
	4-991-161-01	LET (50), BOOK	
	4-981-643-01	COVER, BATTERY (For RM-DX55)	

***** HARDWARE LIST *****			
#1	7-685-871-09	SCREW +BVTT 3X6 (S)	
#2	7-685-871-01	SCREW +BVTT 3X6 (S)	
#3	7-685-873-09	SCREW +BVTT 3X10 (S)	
#4	7-685-107-11	SCREW +P 2X12 TYPE2 NON-SLIT	
#5	7-685-534-19	SCREW +BTP 2.6X8 TYPE2 N-S	
#6	7-685-646-79	SCREW +BVTP 3X8 TYPE2 N-S	
#7	7-621-770-67	SCREW +PWH 2.6X6	
#8	7-685-872-09	SCREW +BVTT 3X8 (S)	
#9	7-685-132-19	SCREW +BTP 2.6X5 TYPE2 N-S	
#10	7-621-772-20	SCREW +B 2X5	
#11	7-682-255-15	SCREW +P 2X3	
#12	7-685-135-19	SCREW +P 2.6X10	
#13	7-621-770-67	SCREW +B 2.6X6	

The components identified by mark △ or dotted line with mark △ are critical for safety. Replace only with part number specified.	Les composants identifiés par une marque △ sont critiques pour la sécurité. Ne les remplacer que par une pièce portant le numéro spécifié.
--	--

