

CDP-C79ES/C89ES

SERVICE MANUAL

US Model
CDP-C79ES/C89ES

Canadian Model
AEP Model
E Model
CDP-C79ES



Photo: CDP-C89ES

Model Name Using Similar Mechanism	CDP-C322M
Optical Pick-up Block Type	BU-5BD8B

SPECIFICATIONS

Compact Disc Player

System	Compact disc digital audio system
Laser	Semiconductor laser ($\lambda = 780 \text{ nm}$) Emission duration: continuous
Laser output	Max. $44.6 \mu\text{W}^*$ * This output is the value measured at a distance of about 200 mm from the objective lens surface on the Optical Pick-up Block.
Frequency response	20 Hz - 20 kHz ($\pm 0.3 \text{ dB}$)
Signal to noise ratio	More than 115 dB
Dynamic range	More than 100 dB
Harmonic distortion	Less than 0.0020% (CDP-C89ES/C79ES)
Channel separation	More than 110 dB

Outputs

LINE OUT (FIXED) (phono jacks)	Output level 2 V (at 50 kilohms, non DSP mode) Load impedance over 10 kilohms
LINE OUT (VARIABLE) (phono jacks)	Output level max 2 V (at 50 kilohms, non DSP mode) Load impedance over 10 kilohms
DIGITAL OUTPUT (OPTICAL) (optical output connector)	Wave length 660 nm Output level -18 dBm
PHONES (stereo phone jack)	Output level max. 15 mW Load impedance 32 ohms

General

Power requirements	US, Canadian model: 120 V AC, 60 Hz AEP model: 220 V AC, 50/60 Hz E model: 110-120 V or 220-240 V AC adjustable 50/60 Hz
Power consumption	18 W
Dimensions (w/h/d)	Approx. $470 \times 125 \times 385 \text{ mm}$ ($18\frac{5}{8} \times 5 \times 15\frac{1}{4}$ inches) (CDP-C89ES/C79ES) Including projecting parts and controls
Weight	Approx. 8.7 kg (19 lbs 3 oz), net (CDP-C89ES) Approx. 8 kg (17 lbs 11 oz), net (CDP-C79ES)

— continued on next page —

COMPACT DISC PLAYER
SONY[®]

- Remote Commander** RM-D715 (CDP-C79ES supplied)
 RM-D815 (CDP-C89ES supplied)
- Remote control system** Infrared control
- Power requirements** 3 V DC with two size AA batteries
 (IEC designation R6)
- Dimensions** 62 × 20 × 175 mm (w/h/d)
 (2¹/₂ × 1³/₁₆ × 7 inches)
- Weight** 130 g (4.6 oz) including batteries

Supplied Accessories

- Connecting cord**
 (2 phono plugs ↔ 2 phono plugs) (1)
- Serial chain cable** (1) (CDP-C89ES only)
- CONTROL S cable** (1) (CDP-C89ES only)
- Remote commander** (1)
- Sony SUM-3(NS)**
- Screws** (1 set)

Design and specifications are subject to change without notice.

For the European Countries.

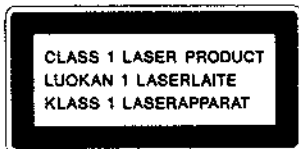

This Compact Disc player is classified as a CLASS 1 LASER product. The CLASS 1 LASER PRODUCT label is located on the rear exterior.

NOTES ON HANDLING THE OPTICAL PICK-UP BLOCK OR BASE UNIT

The laser diode in the optical pick-up block may suffer electrostatic breakdown because of the potential difference generated by the charged electrostatic load, etc. on clothing and the human body.

During repair, pay attention to electrostatic breakdown and also use the procedure in the printed matter which is included in the repair parts.

The flexible board is easily damaged and should be handled with care.

NOTES ON LASER DIODE EMISSION CHECK

The laser beam on this model is concentrated so as to be focused on the disc reflective surface by the objective lens in the optical pick-up block. Therefore, when checking the laser diode emission, observe from more than 30cm away from the objective lens.

Note on the Transit Key

The transit key and the red lock screw (CDP-C89ES only) on the bottom exterior of the unit protects the optical system against shock during transportation. Before operating the CD player, be sure to remove the key and red lock screw (CDP-C89ES only) by following the instructions on the label, and store it in a safe place.

When transporting the unit, replace the key and red lock screw (CDP-C89ES only) in its original hole and lock it in place.

Re-install the red lock screw

1. Open the disc compartment by pressing the OPEN/CLOSE button.
2. Press the DISC SKIP button until disc tray 1 is at the front.
3. Close the disc compartment by pressing the OPEN/CLOSE button.
4. Wait for the (DISC 1) indicator to blink before turning the power off. Re-install the transporting lock screw.

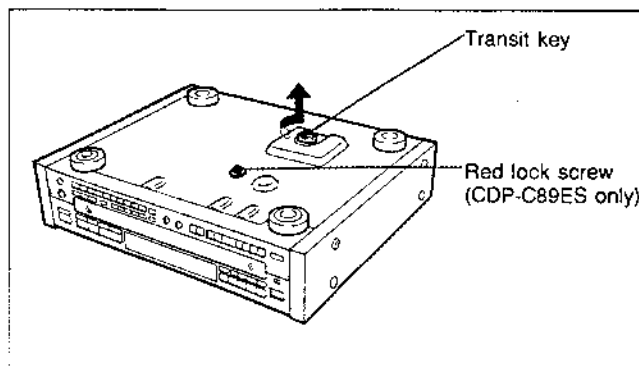

MODEL IDENTIFICATION

— Specification Label —

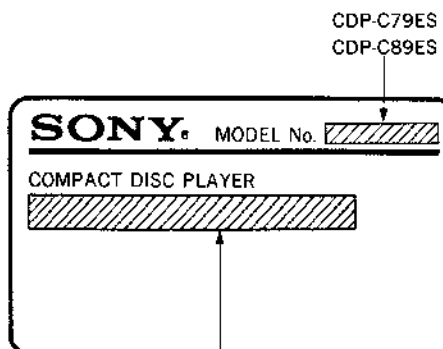

- US, Canadian model: AC: 120V 60Hz
- AEP model: AC: 220-230V~50/60Hz
- E model: AC: 110-120, 220-240V~50/60Hz 18W

SAFETY CHECK-OUT

After correcting the original service problem, perform the following safety check before releasing the set to the customer:

Check the antenna terminals, metal trim, "metallized" knobs, screws, and all other exposed metal parts for AC leakage. Check leakage as described below.

LEAKAGE TEST

The AC leakage from any exposed metal part to earth ground and from all exposed metal parts to any exposed metal part having a return to chassis, must not exceed 0.5 mA (500 microampers). Leakage current can be measured by any one of three methods.

1. A commercial leakage tester, such as the Simpson 229 or RCA WT-540A. Follow the manufacturers' instructions to use these instruments.
2. A battery-operated AC milliammeter. The Data Precision 245 digital multimeter is suitable for this job.
3. Measuring the voltage drop across a resistor by means of a VOM or battery-operated AC voltmeter. The "limit" indication is 0.75 V, so analog meters must have an accurate low-voltage scale. The Simpson 250 and Sanwa SH-63Trd are examples of a passive VOM that is suitable. Nearly all battery operated digital multimeters that have a 2 V AC range are suitable. (See Fig. A)

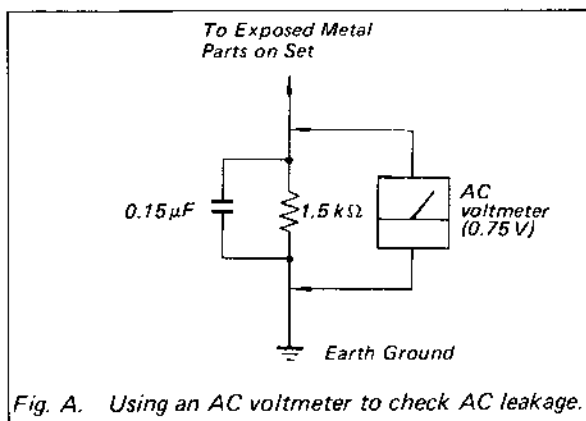



Fig. A. Using an AC voltmeter to check AC leakage.

TABLE OF CONTENTS

<u>Section</u>	<u>Title</u>	<u>Page</u>
1. GENERAL		
	Location of Controls.....	4
2. DISASSEMBLY		
2-1.	Bottom Plate	5
2-2.	Front Panel (1)	5
2-3.	Front Panel (2)	6
2-4.	Tray Assy	6
3. ELECTRICAL BLOCK CHECKING		7
4. DIAGRAMS		
4-1.	Circuit Boards Location	9
4-2.	Printed Wiring Boards —MD Section—	10
4-3.	Schematic Diagram —MD Section—	11
4-4.	Printed Wiring Boards —Main Section—	13
4-5.	Schematic Diagram —Main Section—	17
4-6.	Semiconductor Lead Layouts	21
5. EXPLODED VIEWS		
5-1.	Cabinet Block (C89ES)	24
5-2.	Cabinet Block (C79ES)	25
5-3.	Front Panel Block	26
5-4.	Chassis Block	27
5-5.	Tray Block	28
5-6.	Optical Pick-up Block	29
6. ELECTRICAL PARTS LIST		30

SAFETY-RELATED COMPONENT WARNING!!

COMPONENTS IDENTIFIED BY MARK  OR DOTTED LINE WITH MARK  ON THE SCHEMATIC DIAGRAMS AND IN THE PARTS LIST ARE CRITICAL TO SAFE OPERATION. REPLACE THESE COMPONENTS WITH SONY PARTS WHOSE PART NUMBERS APPEAR AS SHOWN IN THIS MANUAL OR IN SUPPLEMENTS PUBLISHED BY SONY.

ATTENTION AU COMPOSANT AYANT RAPPORT À LA SÉCURITÉ!

LES COMPOSANTS IDENTIFIÉS PAR UNE MARQUE  SUR LES DIAGRAMMES SCHÉMATIQUES ET LA LISTE DES PIÈCES SONT CRITIQUES POUR LA SÉCURITÉ DE FONCTIONNEMENT. NE REMPLACER CES COMPOSANTS QUE PAR DES PIÈCES SONY DONT LES NUMÉROS SONT DONNÉS DANS CE MANUEL OU DANS LES SUPPLÉMENTS PUBLIÉS PAR SONY.

SECTION 1 GENERAL

This section is extracted from instruction manual.

Location of Controls

Front Panel

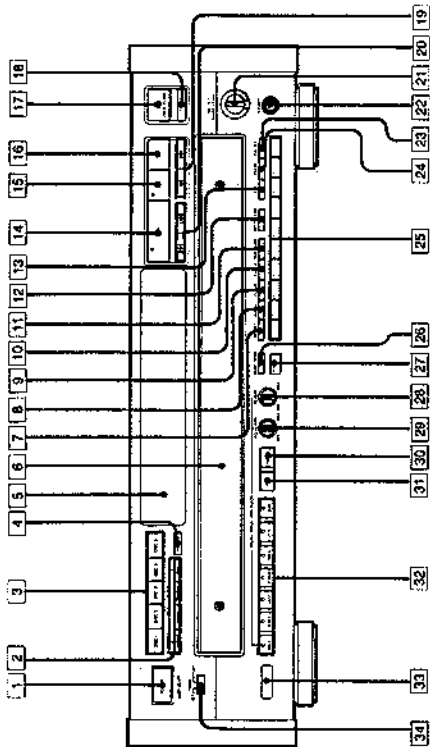

Refer to the pages indicated in () for details.

- 1 POWER switch (page 8)
 - 2 PLAY MODE buttons
CONTINUE button (page 11)
SHUFFLE button (page 11)
PROGRAM button (page 12)
 - 3 DISC 1-5 buttons (page 8)
 - 4 TIME/MEMO button (page 9)
 - 5 Display window (page 8)
 - 6 Disc tray (page 8)
 - 7 REPEAT button (page 18)
 - 8 CHECK button (page 13)
 - 9 CLEAR button (page 13)
 - 10 FADER button (page 16)
 - 11 PEAK SEARCH button (page 17)
 - 12 EDIT/TIME FADE button (page 14)
 - 13 FILE button (page 22)
 - 14 (play) button and indicator (page 8)
 - 15 (pause) button and indicator (page 8)
 - 16 (stop) button (page 8)
 - 17 OPEN/CLOSE button (page 8)
 - 18 DISC SKIP button (page 8)
 - 19 (manual search) buttons (page 10)
 - 20 (AMS*) buttons (page 10)
 - 21 LINE OUT/PHONE LEVEL control (page 8)
 - 22 PHONES jack (page 8)
 - 23 LEVEL FILE button (page 26)
 - 24 ERASE button (page 22)
 - 25 Numeric buttons (1-10) (page 10)
 - 26 MUSIC SCAN button (page 19)
 - 27 > 10 (lower 10) button (page 10)
 - 28 DSP REVERB level control (page 20)
 - 29 DSP EQUALIZER level control (page 20)
 - 30 DSP FILE button (page 21)
 - 31 FLAT button
 - 32 DSP mode buttons and indicators (page 20)
BGM button
LIVE ROOM button
DISCO button
STADIUM button
JAZZ CLUB button
CHURCH button
HALL button
 - 33 Remote sensor
 - 34 TIMER switch (page 27)
- * AMS is the abbreviation of Automatic Music Sensor.

Remote Commander

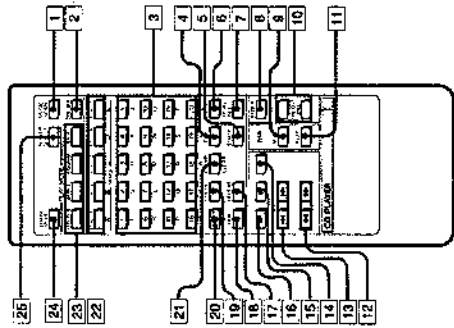

Refer to the pages indicated in { } for details.

- 1 MUSIC SCAN button (page 19)
 - 2 DISC SKIP button (page 8)
 - 3 Numeric buttons (1-20) (page 10)
 - 4 FILE button (page 22)
 - 5 ERASE button (page 22)
 - 6 MEMO INPUT button (page 24)
 - 7 LEVEL FILE button (page 26)
 - 8 FADER button (page 16)
 - 9 DSP SELECT button (page 5)
 - 10 LINE OUT LEVEL buttons (page 5)
 - 11 DSP FLAT button (page 20)
 - 12 (manual search) buttons (page 10)
 - 13 (AMS) buttons (page 10)
 - 14 (stop) button (page 8)
 - 15 (pause) button (page 8)
 - 16 (play) button (page 8)
 - 17 REPEAT button (page 18)
 - 18 TIME button (page 9)
 - 19 CHECK (program check) button (page 13)
 - 20 > 20 (lower 20) button (page 10)
 - 21 CLEAR (program clean) button (page 13)
 - 22 DISC 1-5 buttons (page 12)
 - 23 PLAY MODE buttons
CONTINUE button (page 11)
SHUFFLE button (page 11)
PROGRAM button (page 12)
BANK button (page 23)
 - 24 CHAIN MODE button (CDP-C89ES only) (page 28)
 - 25 PLAYER SELECT button (CDP-C89ES only) (page 29)
- Buttons with orange letters (A, B, C,) are for writing a disc memo (page 24).

Preparing the Remote Commander

Installing Batteries

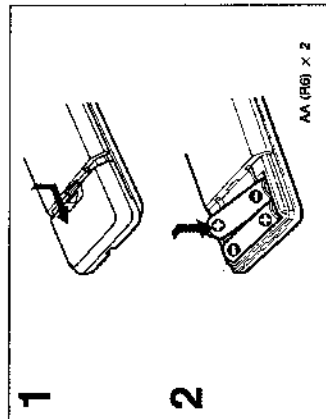

- On battery life**
- About half a year of normal operation can be expected when using the Sony SUM-3(NIS) batteries.
 - When the batteries are run down, the remote commander will not operate the UNIT. In this case, replace both batteries with new ones.

- Notes on the remote commander and remote control operation**
- Keep the commander away from extremely hot or humid places.
 - Avoid dropping any foreign objects into the commander casing, particularly when replacing the batteries.
 - Avoid exposing the remote sensor to direct sunlight or lighting apparatus. Such exposure can cause a malfunction.
 - To avoid damage caused by battery leakage and corrosion, remove the batteries when the commander will not be used for a long time.

SECTION 2 DISASSEMBLY

Note : Follow the disassembly procedure in the numerical order given.

2-1. BOTTOM PLATE

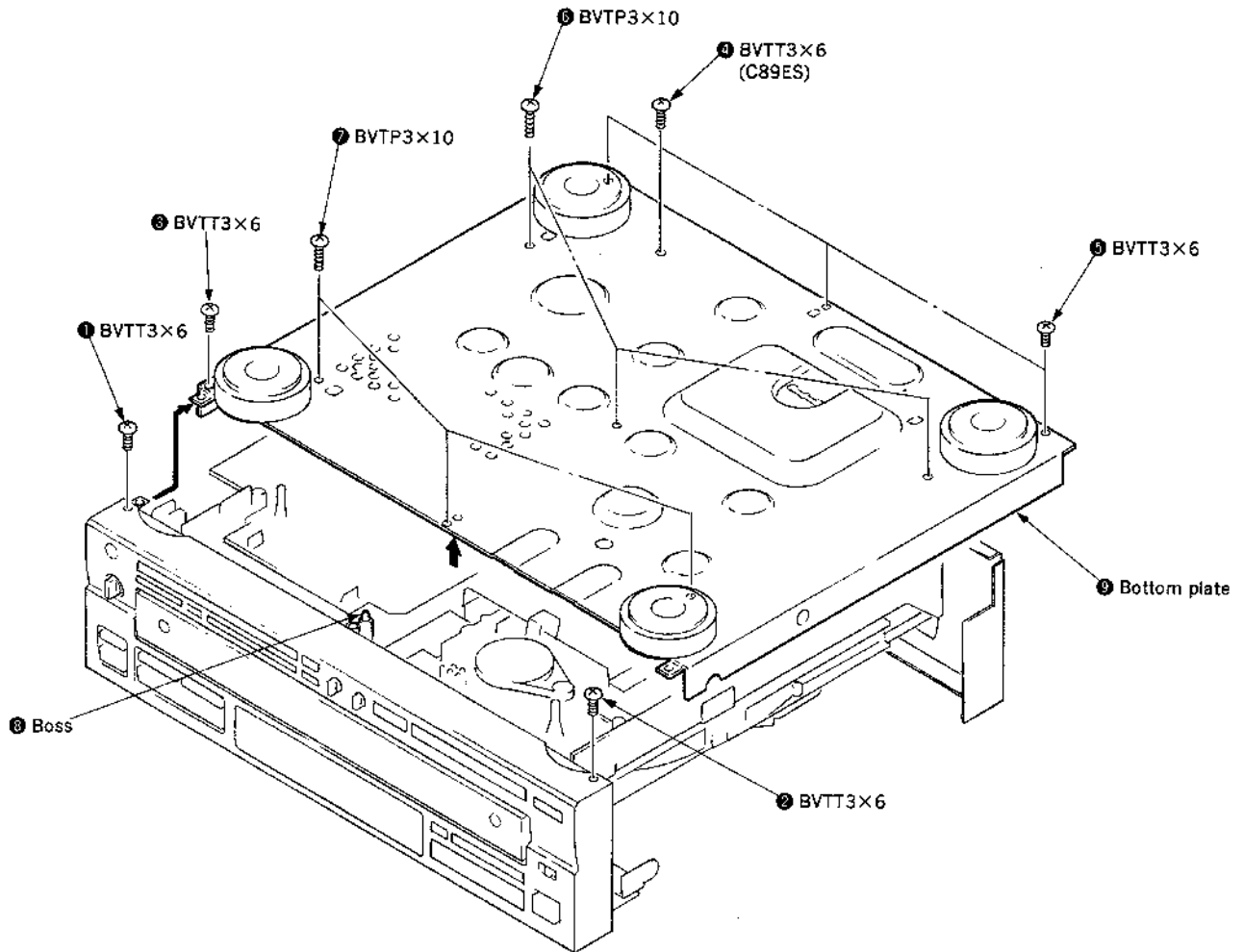

2-2. FRONT PANEL (1)

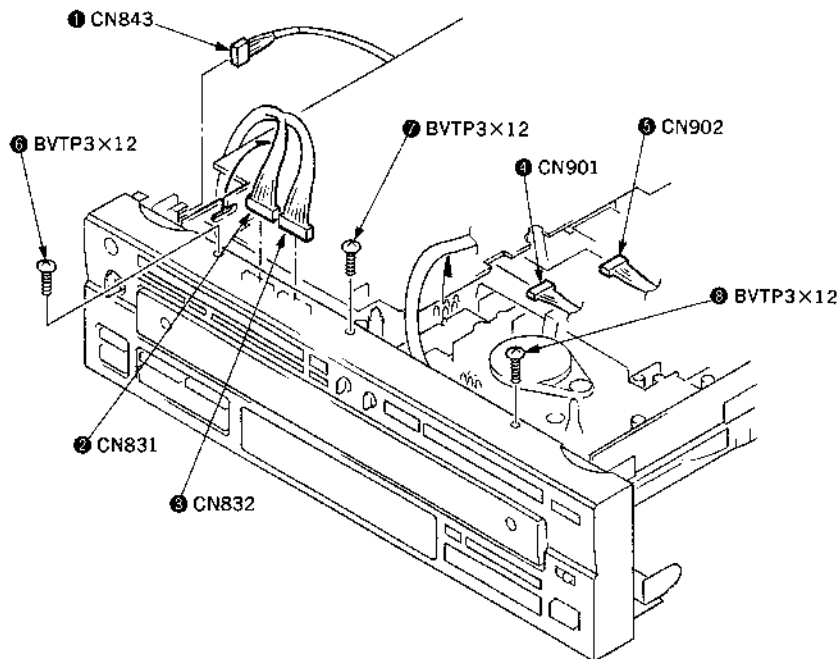

2-3. FRONT PANEL (2)

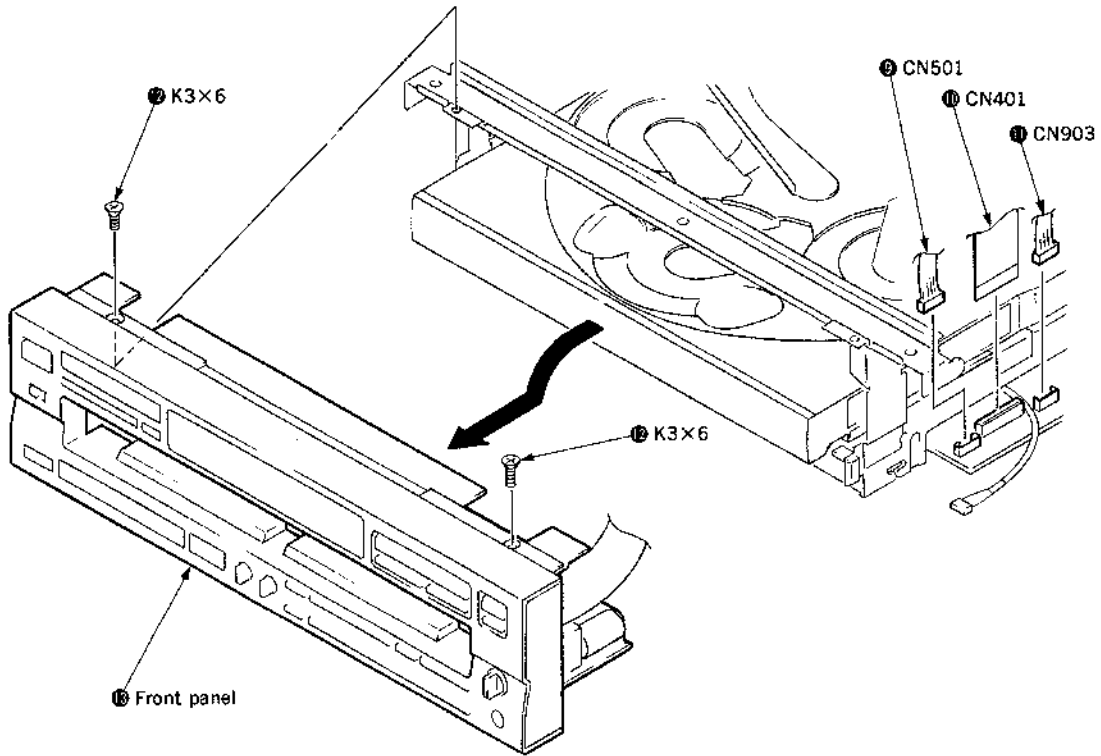

2-4. TRAY ASSY

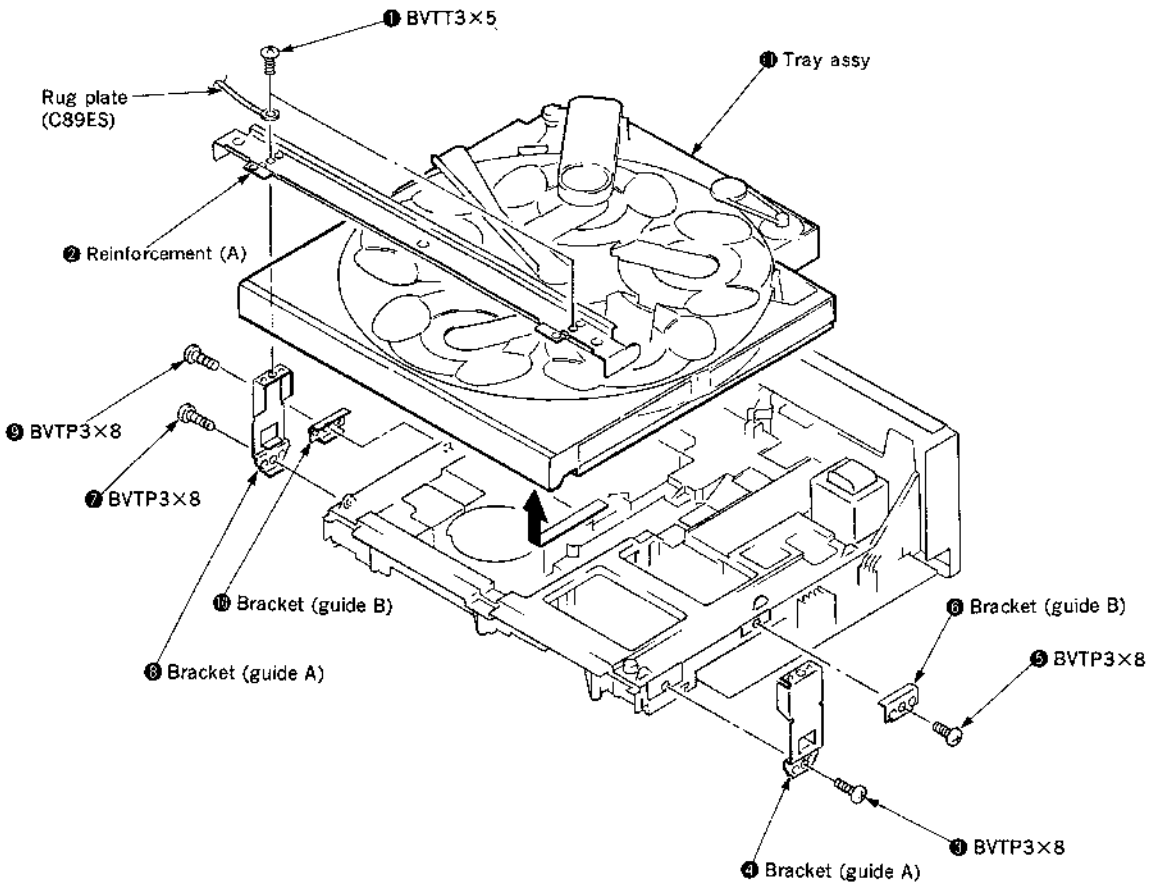

SECTION 3 ELECTRICAL BLOCK CHECKING

Note :

1. CD Block basically constructed to operate without adjustment. Therefore, check each item in order given.
2. Use YEDS-18 disc (3-702-101-01) unless otherwise indicated.
3. Use the oscilloscope with more than 10MΩ impedance.
4. Clean an object lens by an applicator with neutral detergent when the signal level is low than specified value with the following checks.

S Curve Check

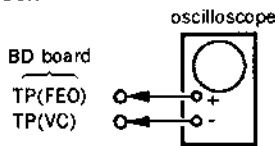

Procedure :

1. Connect oscilloscope to test point TP (FEO) on BD board.
2. Connect between test point TP (FES) and TP (VC) by lead wire.
3. Turned Power switch on and actuate the focus serch. (actuate the focus serch when disc table is moving in and out.)
4. Check the oscilloscope waveform (S curve) is symmetrical between A and B. And confirm peak to peak level within $3 \pm 1V_{p-p}$.

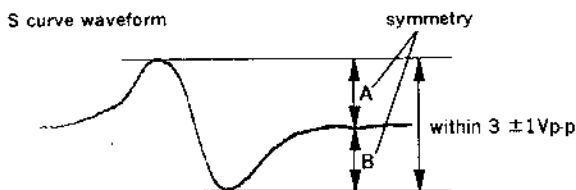

5. After check, remove the lead wire connected in step 2.

Note :

- Try to measure several times to make sure that the ratio of A : B or B : A is more than 10 : 7.
- Take sweep time as long as possible and light up the brightness to obtain best waveform.

RF Level Check

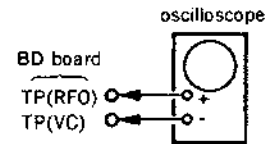

Procedure :

1. Connect oscilloscope to test point TP (RFO) on BD board.
2. Turn Power switch on.
3. Put disc (YEDS-18) in and playback.
4. Confirm that oscilloscope waveform is clear and check RF signal level is correct or not.

Note :

Clear RF signal waveform means that the shape "◇" can be clearly distinguished at the center of the waveform.

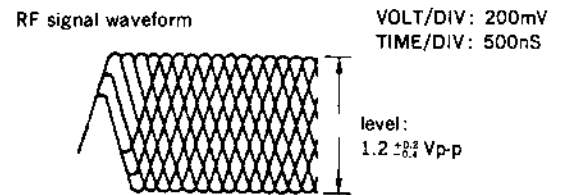

E-F Balance Check

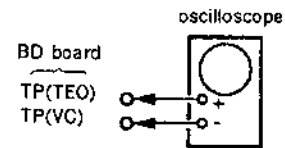

Procedure :

1. Connect test point TP (ADJ) to ground and TP (TES) to TP (VC) with lead wire.
2. Connect oscilloscope to test point TP (TEO) on BD board.
3. Turn Power switch on.
4. Put disc (YEDS-18) in and playback.
5. Confirm that the osilloscope waveform is symmetrical on the top and bottom in relation to 0V, and check this level.

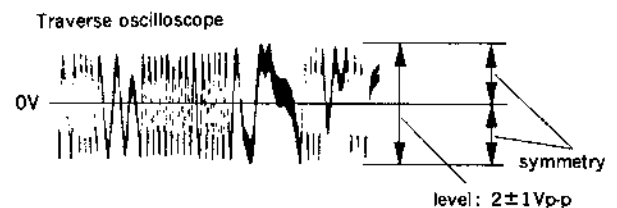

6. Remove the lead wire connected in step 1.

RF PLL Free-run Frequency Check

Procedure :

1. Connect frequency counter to test point (PLCK) with lead wire.

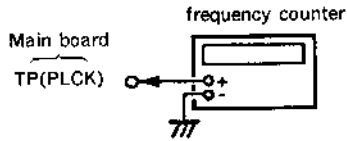

2. Turn Power switch on.
3. Confirm that reading on frequency counter is 4.3218MHz.

Focus/Tracking Gain

This gain has a margin, so even if it is slightly off.

There is no problem.

Therefore, do not perform, this adjustment.

Please note that it should be fixed to mechanical center position when you moved and do not know original position.

Adjustment Locations :

[BD Board]

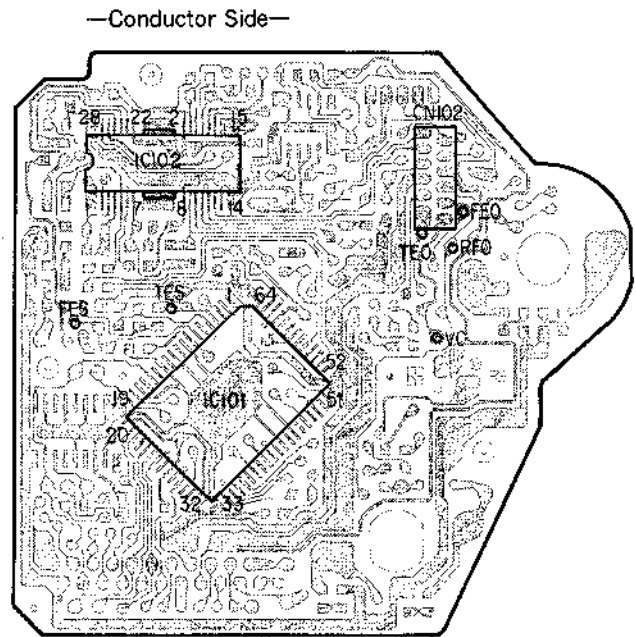

[MAIN Board]

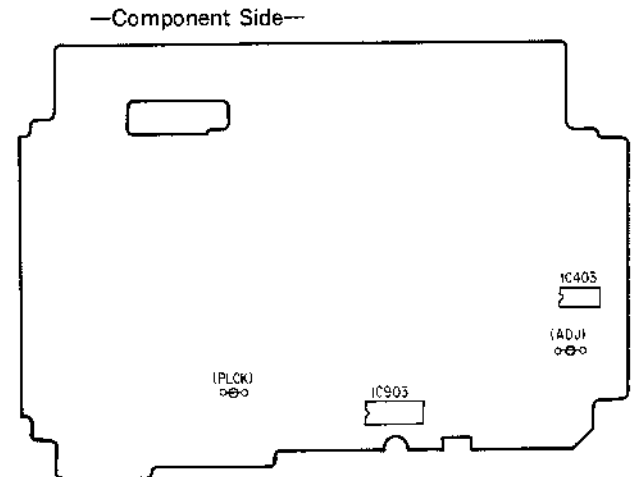

SECTION 4 DIAGRAMS

4-1. CIRCUIT BOARDS LOCATION

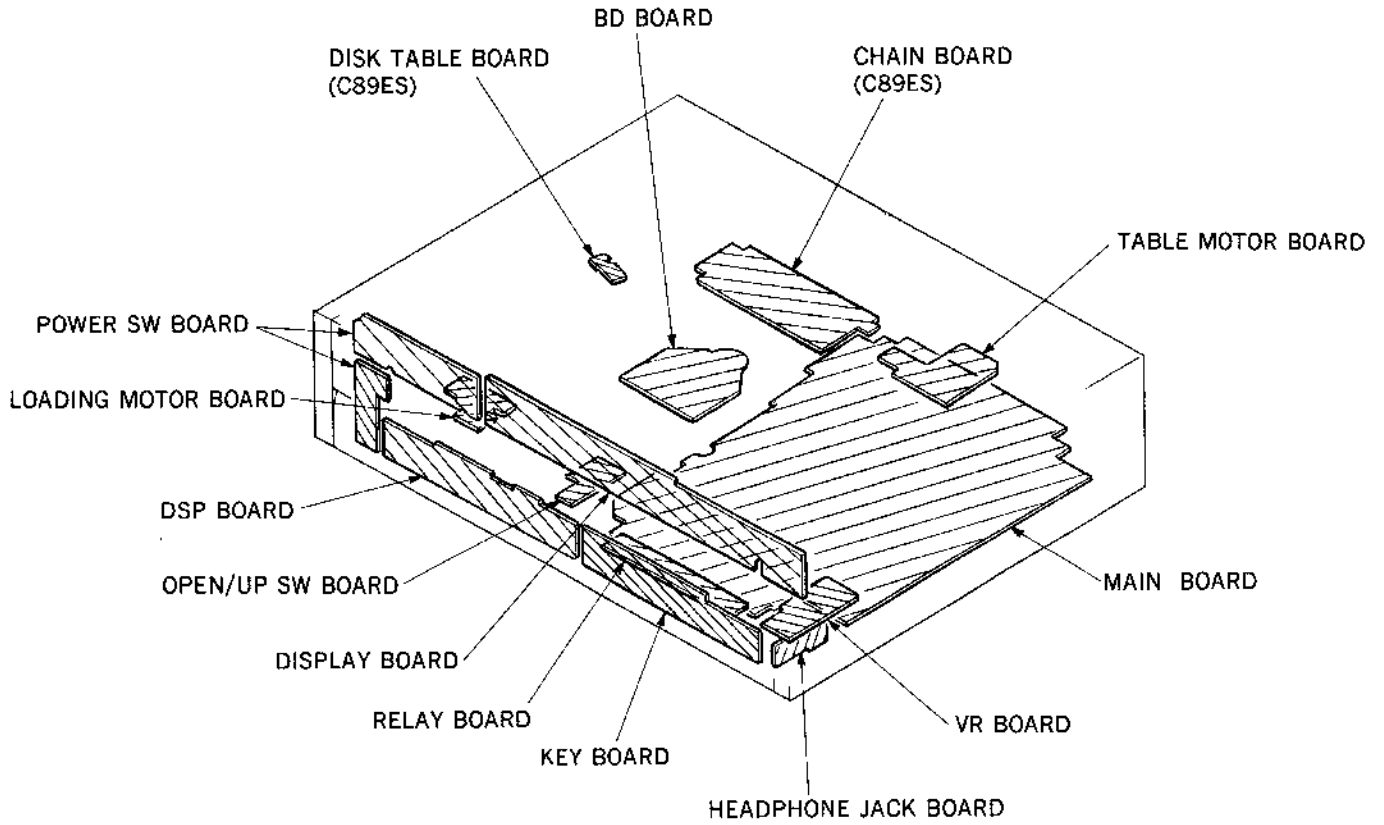

4-2. PRINTED WIRING BOARDS — MD SECTION — • Refer to page 21 for Semiconductor Lead Layouts.

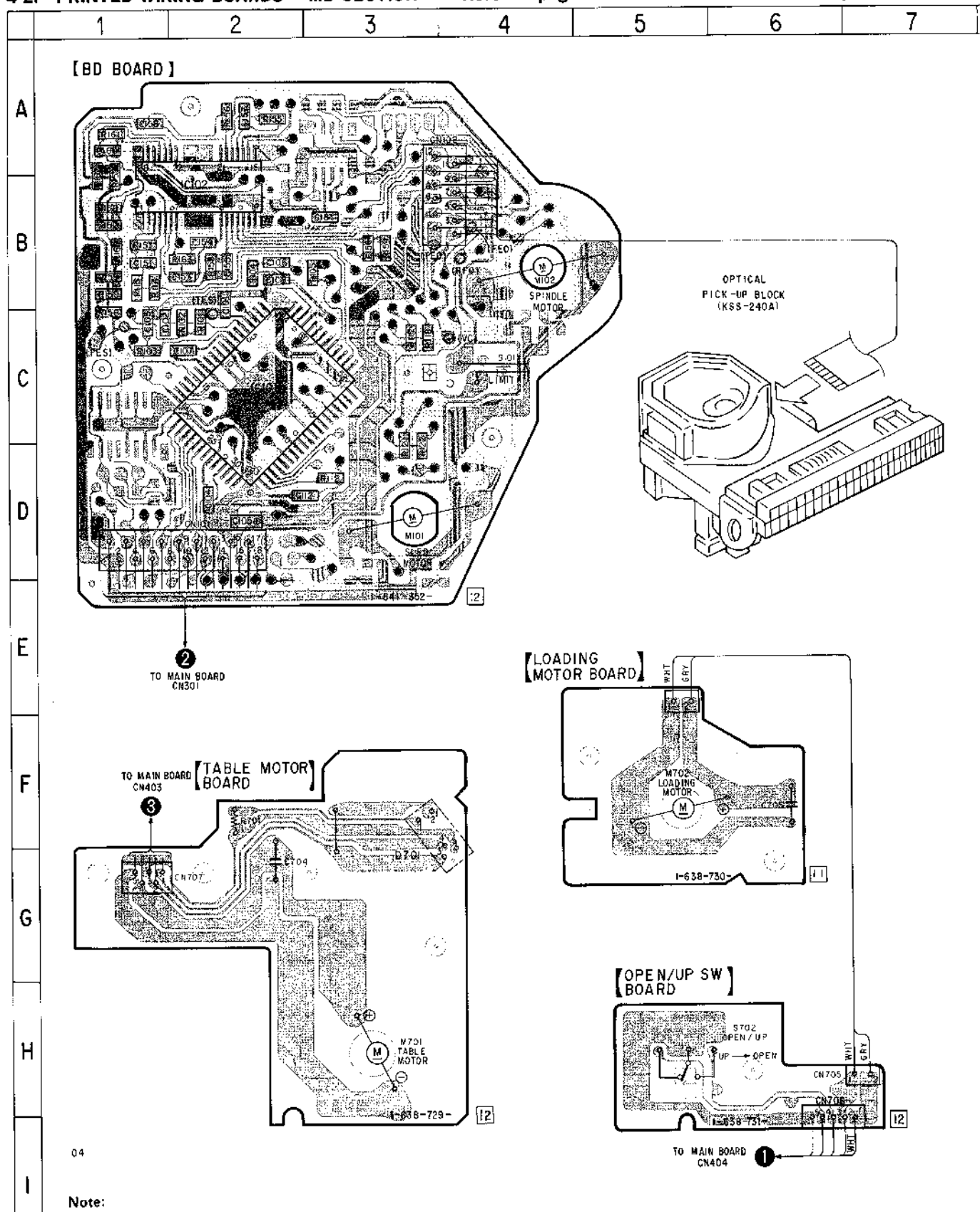

04

- Note:**
- ◆ ○ — : parts extracted from the component side.
 - : Through hole.
 - ▨ : Pattern on the side which is seen.
 - ⊖ : Pattern of the rear side.

4-3. SCHEMATIC DIAGRAM —MD SECTION— • Refer to page 22 for IC Block Diagrams.

• Refer to page 20 for Waveforms.

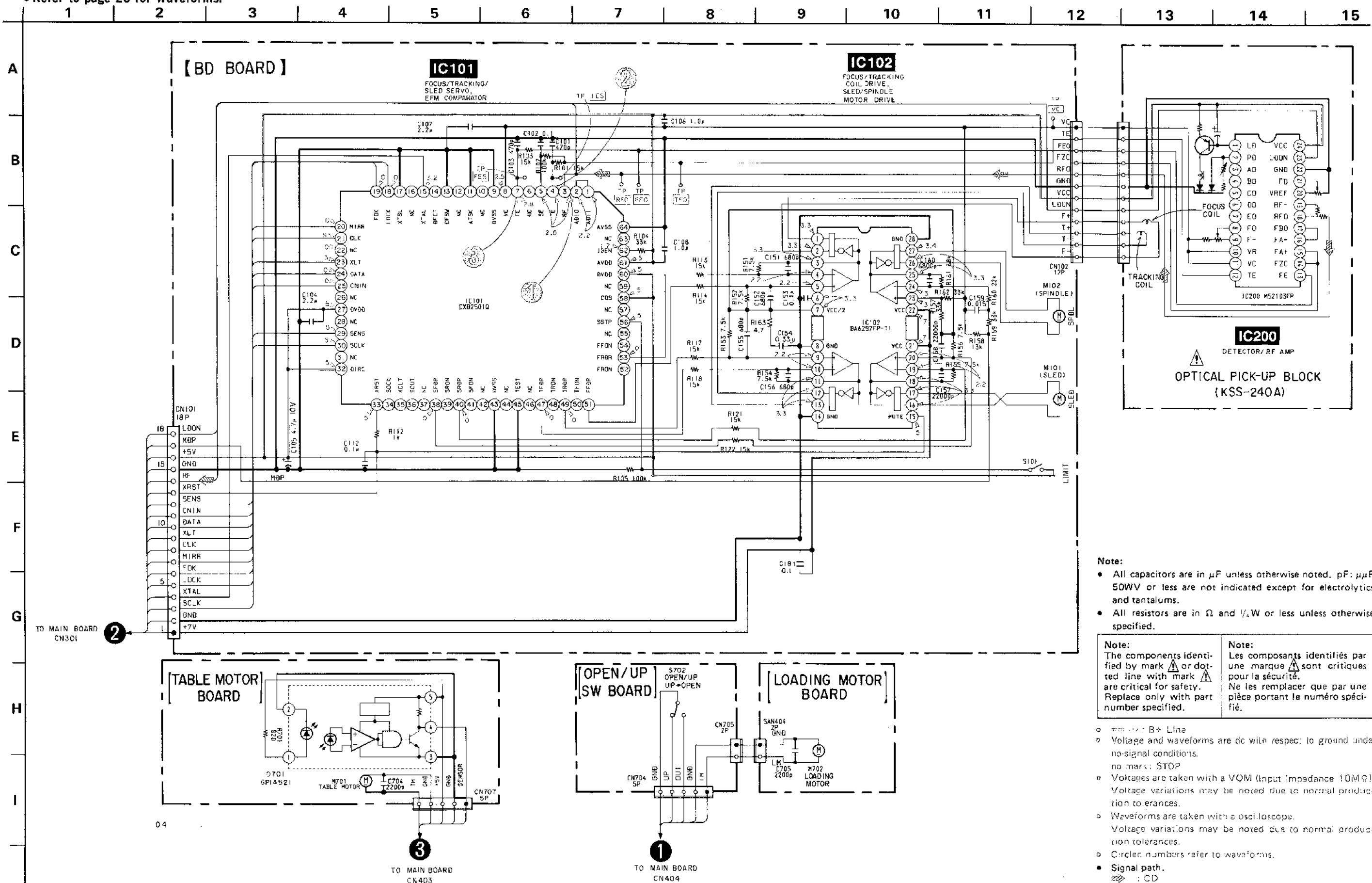

Note:

- All capacitors are in μF unless otherwise noted. pF : μF 50WV or less are not indicated except for electrolytics and tantalums.
- All resistors are in Ω and $\frac{1}{2}\text{W}$ or less unless otherwise specified.

<p>Note: The components identified by mark Δ or dotted line with mark Δ are critical for safety. Replace only with part number specified.</p>	<p>Note: Les composants identifiés par une marque Δ sont critiques pour la sécurité. Ne les remplacer que par une pièce portant le numéro spécifié.</p>
--	--

- Δ : B+ Line
- Voltage and waveforms are dc with respect to ground under no-signal conditions.
- no mark: STOP
- Voltages are taken with a VOM (Input impedance $10\text{M}\Omega$). Voltage variations may be noted due to normal production tolerances.
- Waveforms are taken with a oscilloscope. Voltage variations may be noted due to normal production tolerances.
- Circled numbers refer to waveforms.
- Signal path.
- CD

• Semiconductor Location

Ref. No.	Location	Ref. No.	Location
D201	B-23	IC307	D-21
D202	B-23	IC308	G-28
D203	C-25	IC401	H-17
D204	C-25	IC402	I-17
D205	D-25	IC403	F-16
D206	D-25	IC571	E-16
D208	F-21	IC751	D-30
D209	F-21	IC801	D-8
D211	C-23	IC811	H-12
D212	C-23	IC901	I-25
D213	C-23	IC902	I-26
D214	C-23	IC903	H-20
D341	C-17	IC904	H-26
D351	G-18	IC910	E-19
D401	H-17		
D571	C-19	Q201	B-24
D601	F-27	Q203	B-22
D602	F-27	Q204	B-20
D603	F-27	Q205	B-21
D751	D-29	Q206	B-20
D752	D-29	Q341	F-19
D753	D-29	Q342	F-19
D754	C-30	Q343	F-19
D755	C-30	Q344	C-17
D756	C-30	Q345	F-18
D757	E-30	Q346	D-17
D758	F-30	Q371	E-18
D759	F-30	Q372	D-18
D801	D-7	Q373	E-18
D802	D-7	Q374	D-18
D803	D-7	Q375	F-18
D804	D-7	Q376	D-18
D805	D-7	Q573	C-19
D806	D-7	Q574	C-18
D807	C-4	Q575	C-19
D808	C-5	Q576	C-19
D851	J-15	Q577	C-19
D852	J-14	Q601	F-27
D853	J-14	Q602	F-27
D854	J-13	Q603	F-27
D855	J-12	Q604	F-27
D856	J-12	Q801	C-10
D857	J-11	Q802	C-10
D902	E-17	Q803	D-10
		Q804	D-10
IC201	B-24	Q901	F-20
IC202	D-24	Q902	F-20
IC203	F-26	Q903	F-20
IC204	G-21	Q941	F-20
IC205	D-21	Q942	F-19
IC206	D-21	Q943	F-19
IC301	I-23	Q971	D-19
IC302	H-24	Q972	D-19
IC303	F-24	Q973	D-19
IC306	F-21		

- Note:
- : parts extracted from the component side.
 - : Through hole.
 - ▨ : Pattern on the side which is seen.
 - ◌ : Pattern of the rear side.
 - CND : Canadian model

4-4. PRINTED WIRING BOARDS — MAIN SECTION — • Refer to page 21 for Semiconductor Lead Layouts.

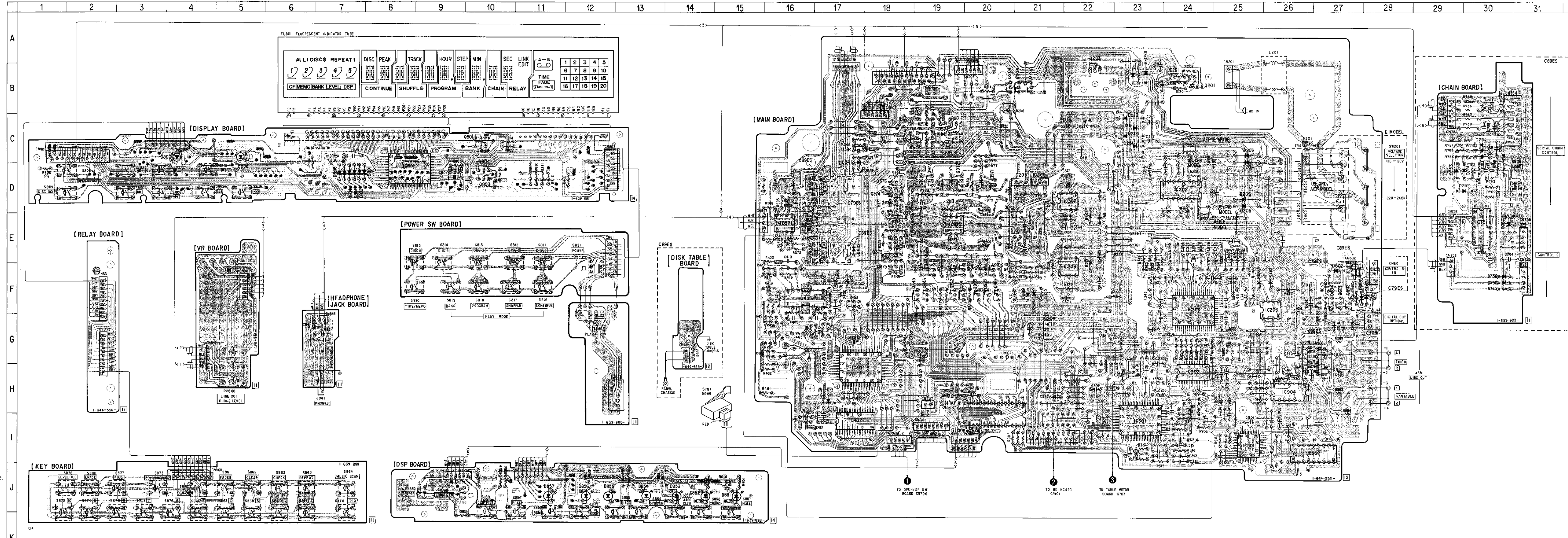

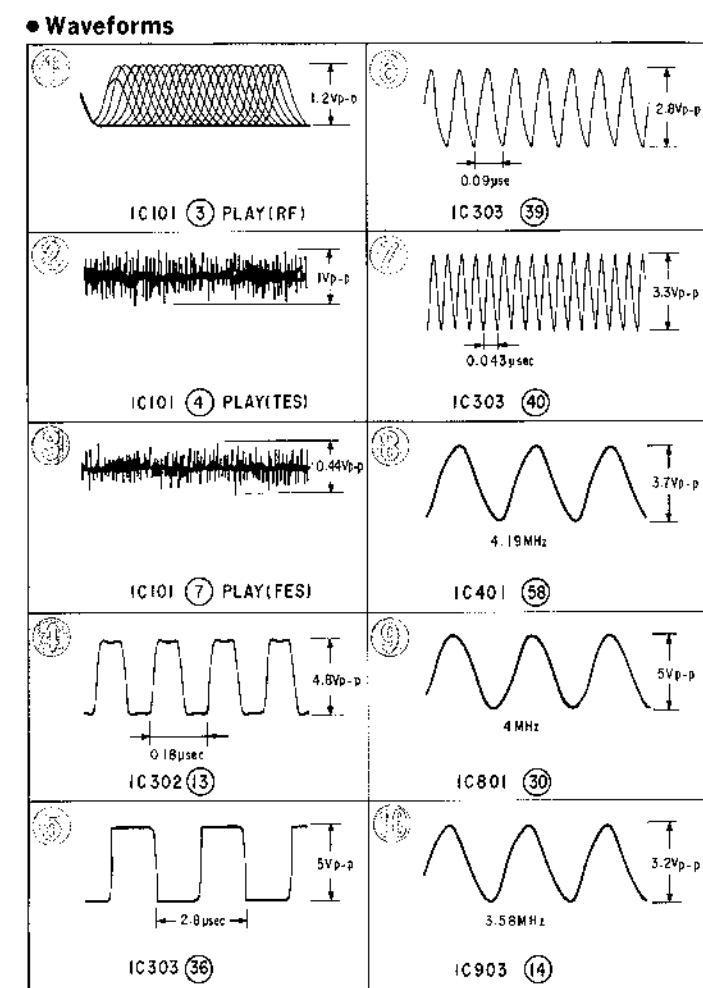
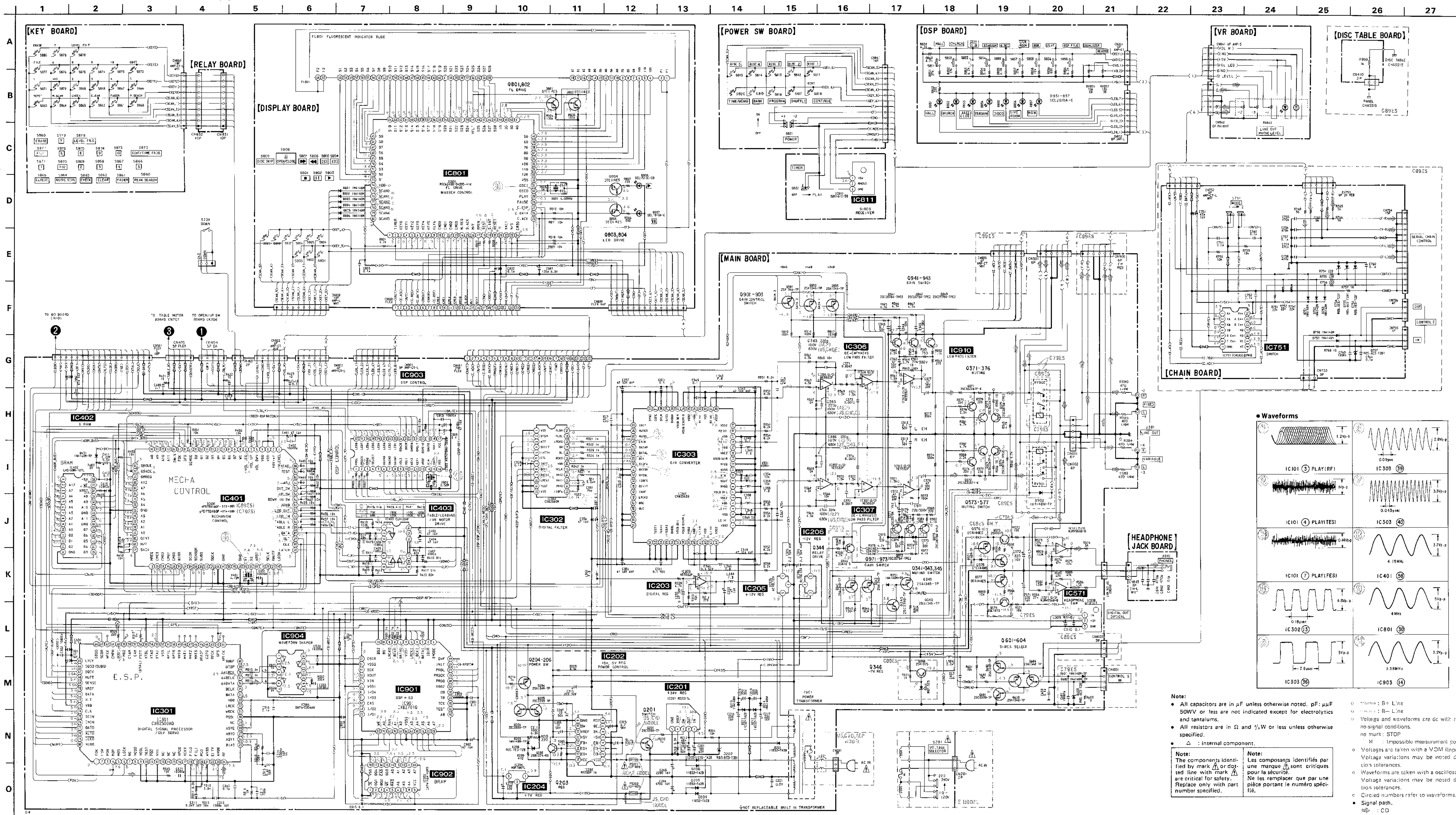

Note:

- All capacitors are in μF unless otherwise noted. $\text{pF} = \mu\text{F} \times 10^{-6}$.
- 90WV or less are not indicated except for electrolytics and tantalums.
- All resistors are in Ω and $\frac{1}{2}\text{W}$ or less unless otherwise specified.
- Δ : internal component.

Note: The components identified by mark Δ or Δ are critical for safety. Replace only with part number specified.

Note: Les composants identifiés par une marque Δ sont critiques pour la sécurité. Ne les remplacer que par une pièce portant le numéro spécifié.

Waveforms

- IC101 (3) PLAY(RF)
- IC303 (39)
- IC101 (4) PLAY(ES)
- IC303 (40)
- IC101 (7) PLAY(FES)
- IC401 (58)
- IC302 (38)
- IC801 (30)
- IC303 (35)
- IC303 (44)

Note:

- Internal component.
- Line.
- Line.
- Volts and waveforms are dc with respect to ground under no-signal conditions. no mark: STOP.
- Impossible measurement point.
- Volts are taken with a VOM (impedance $10\text{M}\Omega$). Voltage variations may be noted due to normal production tolerances.
- Waveforms are taken with an oscilloscope. Voltage variations may be noted due to normal production tolerances.
- Circled numbers refer to waveforms.
- Signal path.
- CD.
- digital out.
- Capacitor model.

4-6. SEMICONDUCTOR LEAD LAYOUTS

BA6297AFP

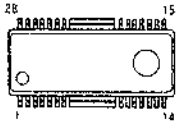

LH5160N-10L

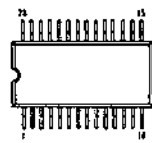

M5290P-16

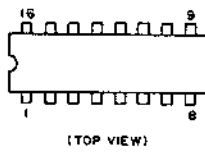

**DTA114ES
DTA144ES
DTC114ES
2SC1815-Y
2SC3622A-LK**

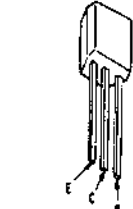

GP-1A521

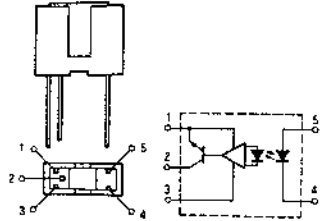

CXA1291P

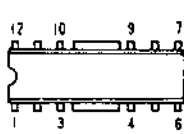

MS51464-10NC

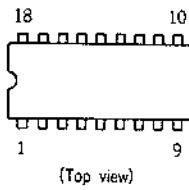

**NE5532P
RC4556D**

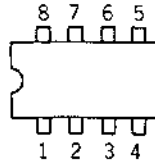

**DTA124ES
DTC144ES
DTC144WS**

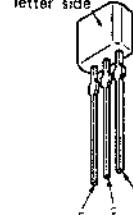

**MTZJ-7.5B
RD5.1ES-B2
RD5.6ES-B
11ES2**

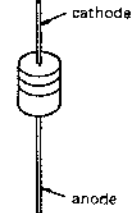

**CXD2500AQ
CXD2501Q
MSC62408-042GS-V1K
μPD75516GF-373-3B9
μPD75516GF-374-3B9**

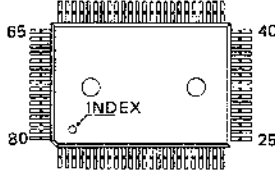

M37470M4-089SP

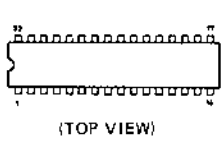

(Top view)

NJM78L12A



**2SA1015-GR
2SC2878-AB**

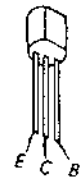

1N4148M

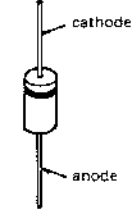

M5F7807L



NJM79L12A

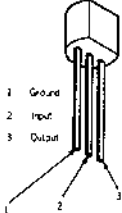

2SB1094-LK

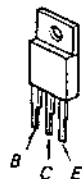

**SEL1510C-CD
SEL1810A-C**

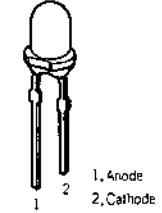

CXD2560M

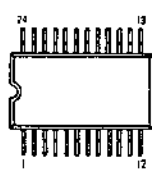

M5231TL



**SN74HCU04N
μPD4066BC**

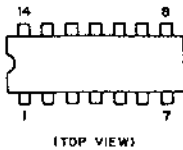

CXD2562Q

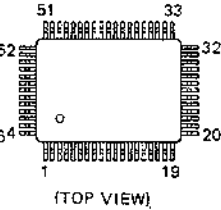

SEL2810A-C

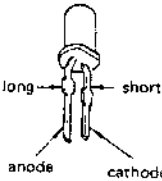

CXD2701Q

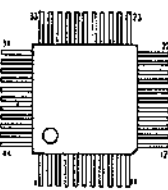

• IC Block Diagrams

IC101 CXD2501Q

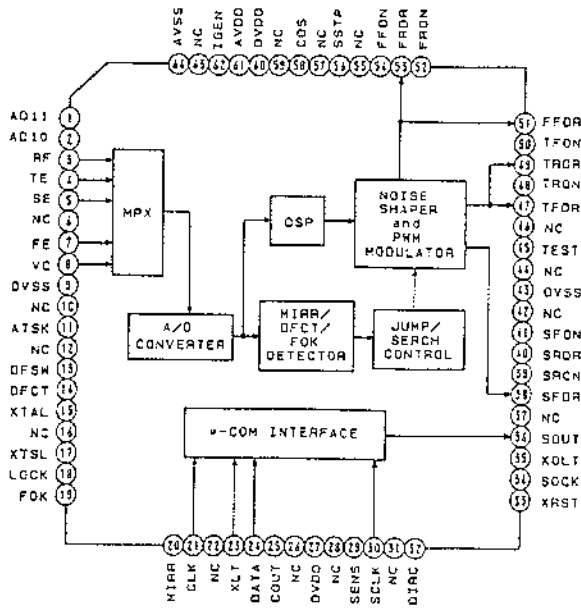

IC202 M5290P-16

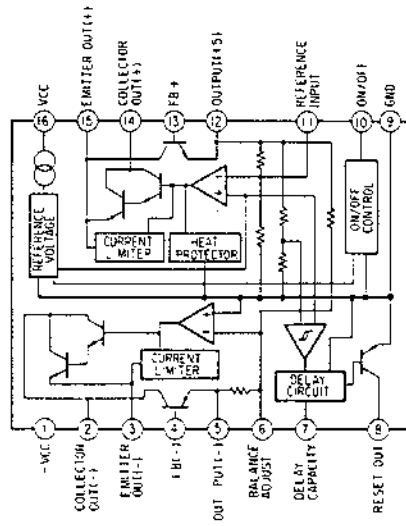

IC201 M5231TL

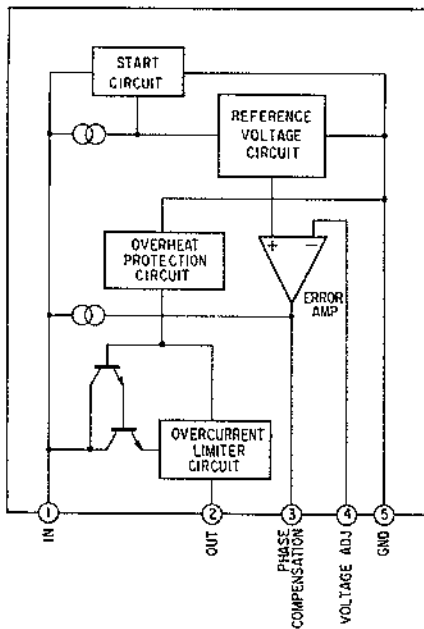

IC301 CXD2500AQ

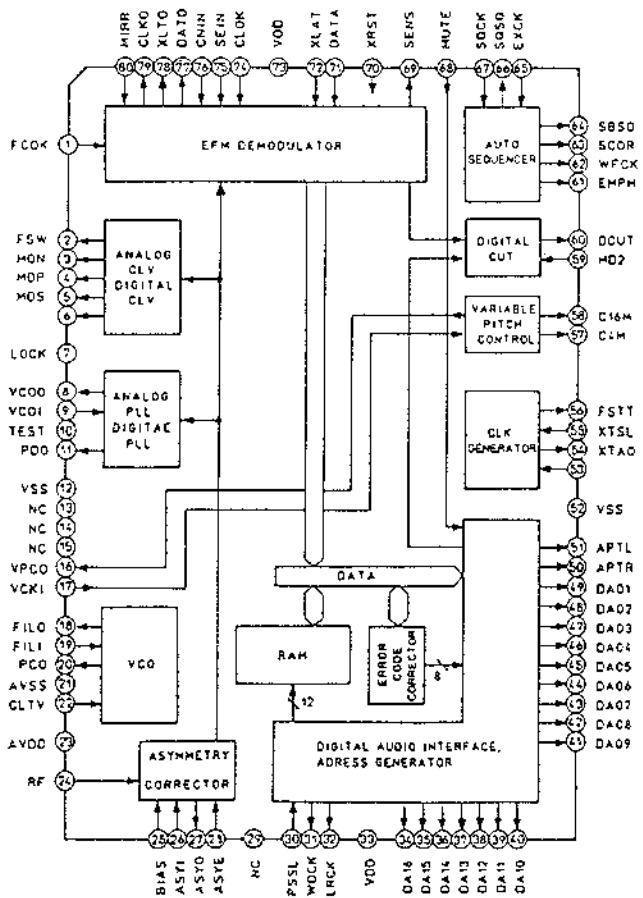

IC302 CXD2560M

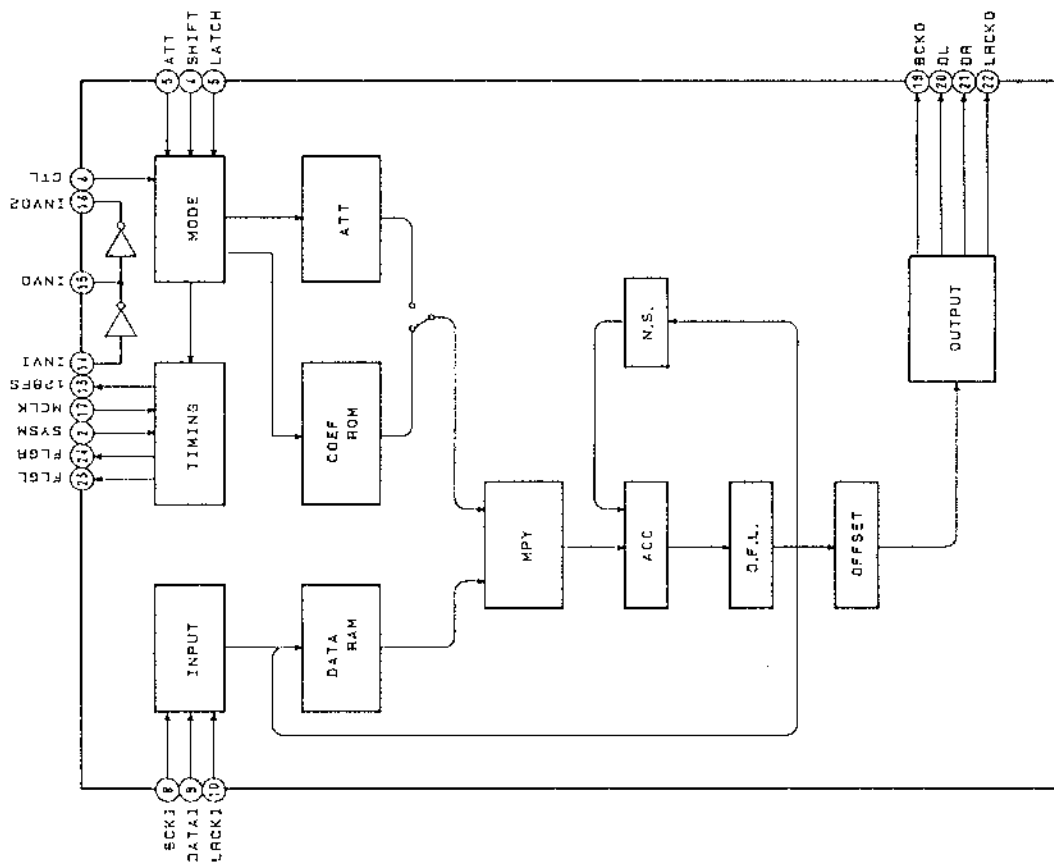

IC901 CXD2701Q

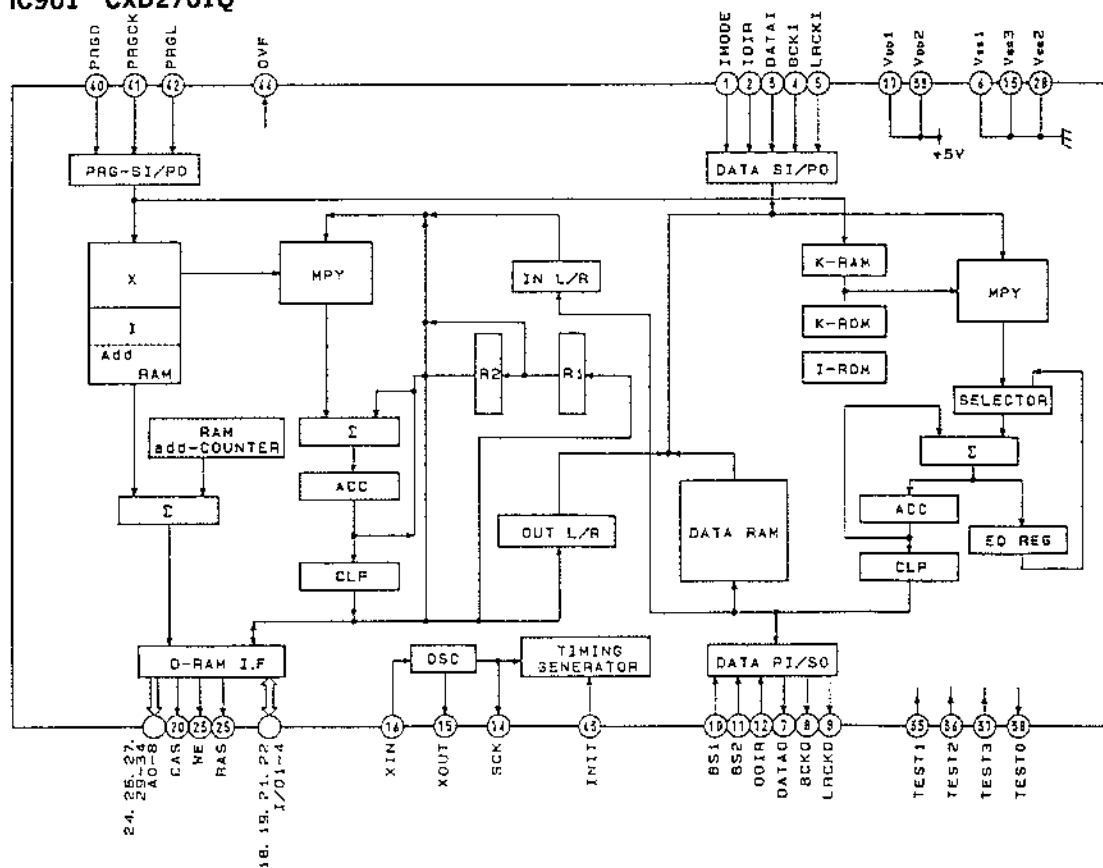

SECTION 5 EXPLODED VIEWS

NOTE:

- The mechanical parts with no reference number in the exploded views are not supplied.
- Items marked "*" are not stocked since they are seldom required for routine service. Some delay should be anticipated when ordering these items.

- -XX and -X mean standardized parts, so they may have some difference from the original one.
- Color Indication of Appearance Parts
Example :
KNOB, BALANCE (WHITE)... (RED)
 ↑ ↑
 Parts Color Cabinet's Color

- Hardware (# mark) list is given in the last of this parts list.

The components identified by mark Δ or dotted line with mark Δ are critical for safety. Replace only with part number specified.

Les composants identifiés par une marque Δ sont critiques pour la sécurité. Ne les remplacer que par une pièce portant le numéro spécifié.

5-1. CABINET BLOCK (C89ES)

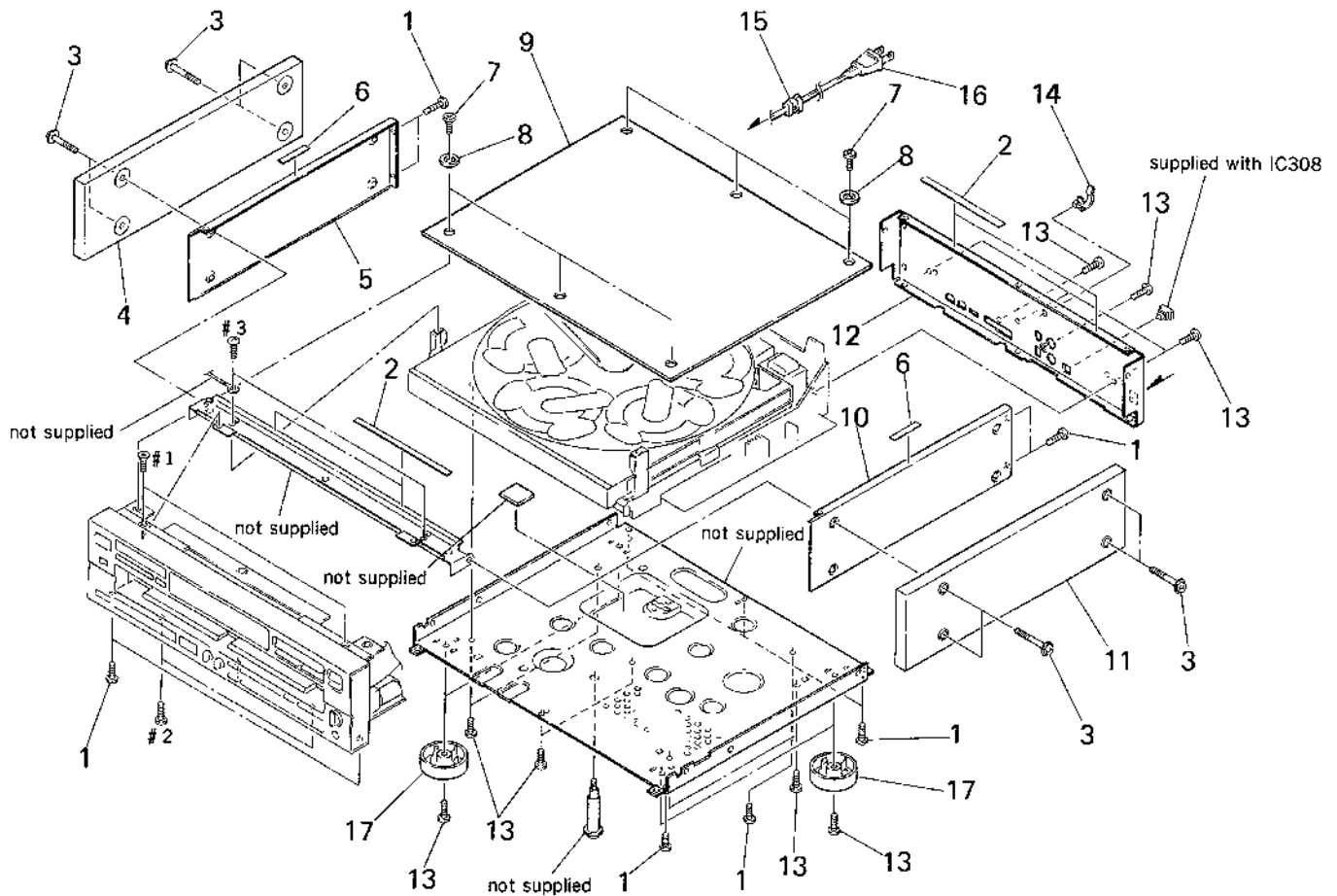

Ref. No.	Part No.	Description	Remark	Ref. No.	Part No.	Description	Remark
1	3-703-108-31	SCREW +BV 3X6, S TIGHT		* 10	4-945-429-01	PLATE (R). SIDE	
* 2	4-927-653-01	SHEET (F/P)		11	X-4941-641-1	PANEL (R) ASSY, SIDE	
3	4-933-446-01	SCREW (SIDE PANEL)		* 12	4-943-718-11	PANEL, BACK	
4	X-4941-640-1	PANEL (L) ASSY, SIDE		13	4-951-621-01	SCREW	
* 5	4-945-428-01	PLATE (L), SIDE		* 14	4-949-235-01	HOOK	
6	3-831-441-XX	CUSHION (B), CABINET		* 15	3-703-244-00	BUSHING (2104), CORD	
7	4-924-242-11	SCREW (M3X6), FLAT HEAD		Δ 16	1-559-583-21	CORD, POWER	
8	4-928-025-11	ESCUTCHEON (TOP PLATE)		17	X-4924-463-1	FOOT ASSY	
9	4-945-422-01	PLATE, TOP					

5-2. CABINET BLOCK (C79ES)

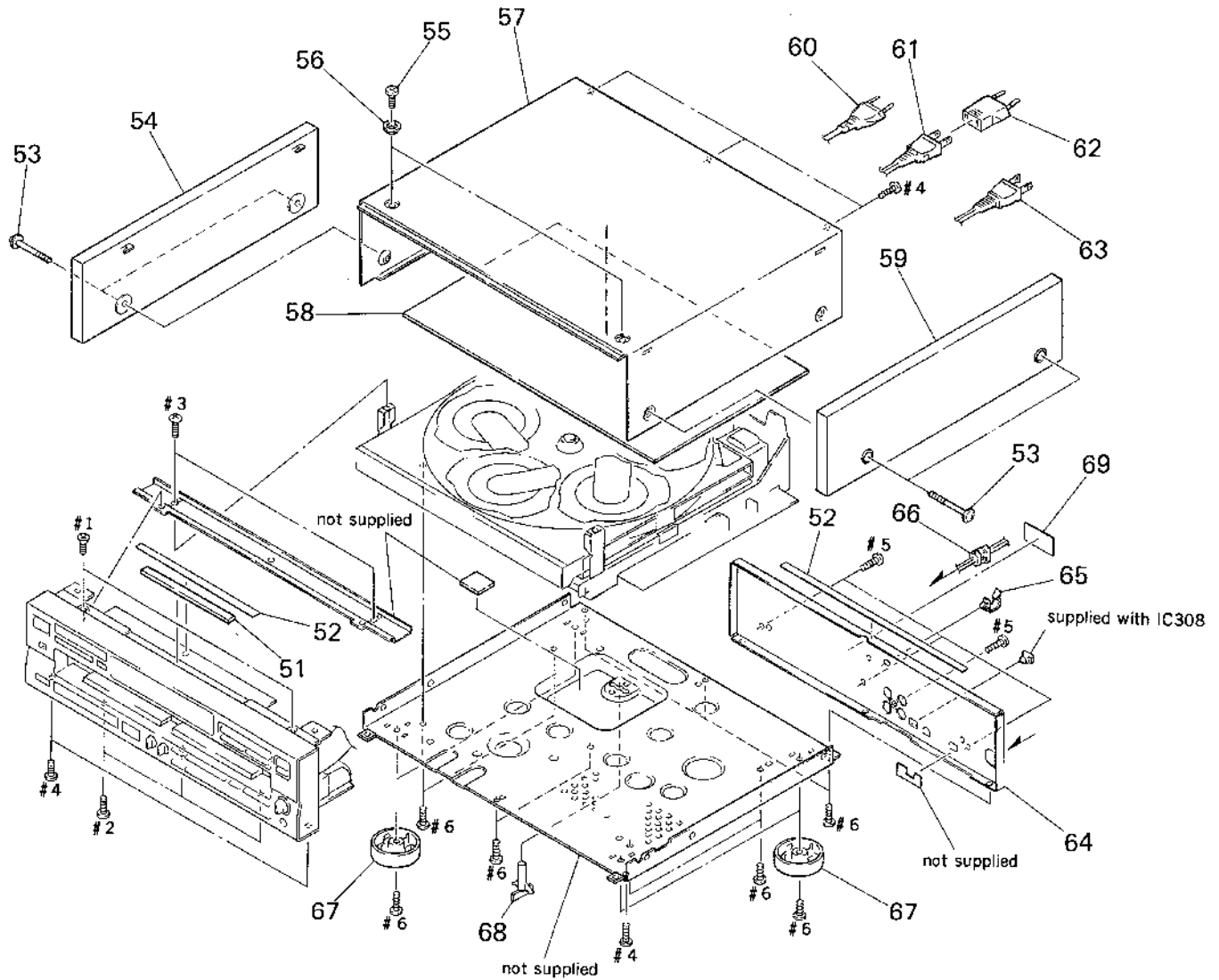

<p>The components identified by mark \triangle or dotted line with mark \triangle are critical for safety. Replace only with part number specified.</p>	<p>Les composants identifiés par une marque \triangle sont critiques pour la sécurité. Ne les remplacer que par une pièce portant le numéro spécifié.</p>
---	--

Ref. No.	Part No.	Description	Remark
* 51	4-929-561-01	CUSHION (CASE)	
* 52	4-927-653-01	SHEET (F/P)	
53	4-933-446-01	SCREW (SIDE PANEL)	
54	X-4924-465-1	PANEL (L) ASSY, SIDE	
55	4-924-242-11	SCREW (M3X6), FLAT HEAD	
56	4-928-025-11	ESCUTCHEON (TOP PLATE)	
* 57	4-937-934-01	CASE	
58	A-4675-309-A	REINFORCEMENT (TOP PLATE) ASSY	
59	X-4924 466-1	PANEL (R) ASSY, SIDE	
\triangle 60	1-558-568-21	CORD, POWER (AEP)	
\triangle 61	1-558-181-21	CORD, POWER (E)	

Ref. No.	Part No.	Description	Remark
\triangle 62	1-569-007-11	ADAPTER, CONVERSION 2P (E)	
\triangle 63	1-559-583-21	CORD, POWER (US, Canadian)	
* 64	4-948-876-01	PANEL, BACK (US, Canadian)	
* 64	4-948-876-21	PANEL, BACK (E)	
* 64	4-948-876-41	PANEL, BACK (AEP)	
* 65	4-949-235-01	HOOK	
* 66	3-703-244-00	BUSHING (2104), CORD	
67	X-4924-463-1	FOOT ASSY	
68	4-937-945-01	PLATE (TRANSPORT), LOCK	
* 69	4-941-548-01	LABEL, CLASS 1 (AEP, E)	

5-3. FRONT PANEL BLOCK

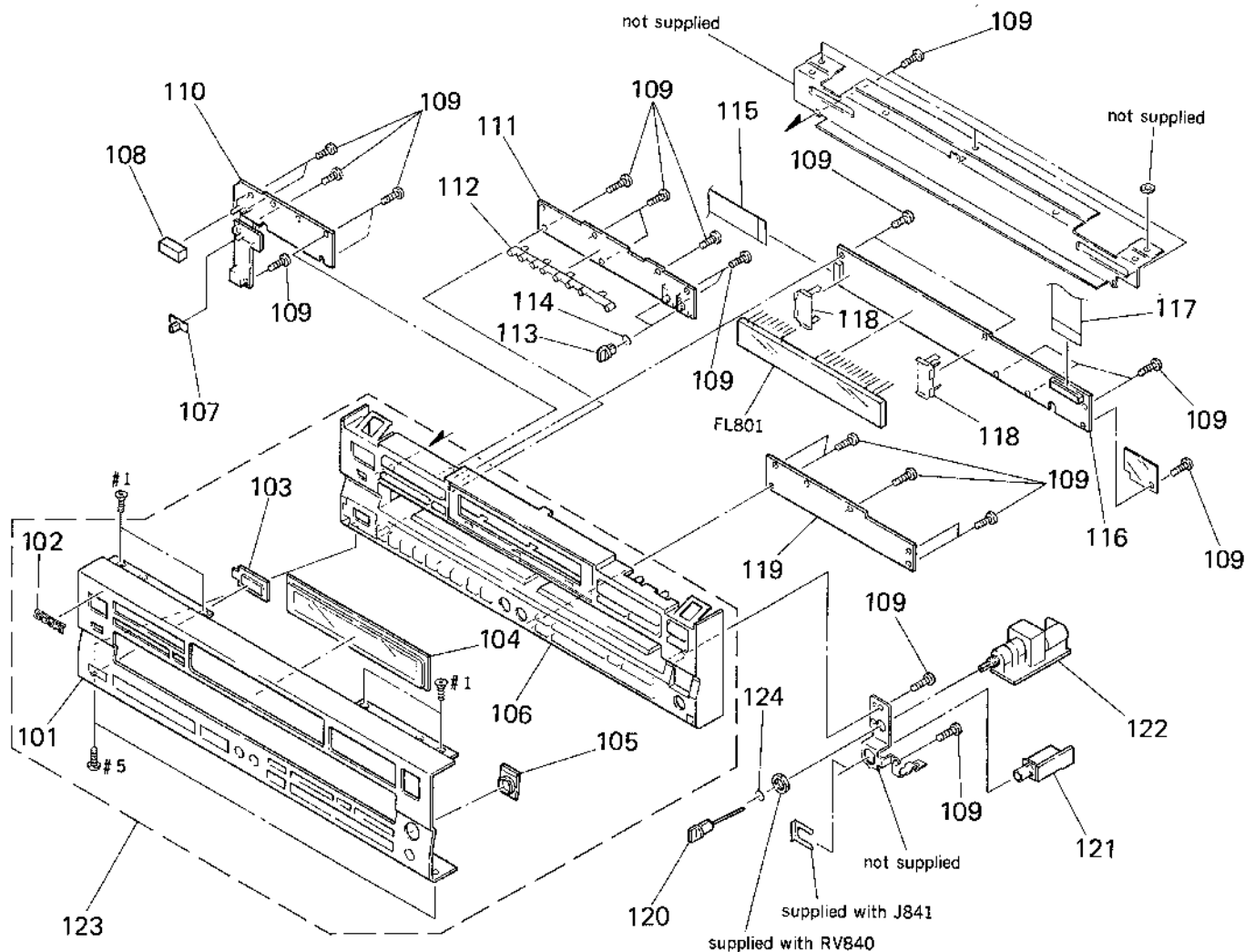

Ref. No.	Part No.	Description	Remark
101	4-944-307-51	PANEL, FRONT (C89ES)	
101	4-944-307-61	PANEL, FRONT (C79ES:US, Canadian)	
101	4-944-307-81	PANEL, FRONT (AEP, E)	
102	4-908-848-01	EMBLEM, SONY	
103	4-945-432-01	PLATE, INDICATION	
104	4-945-418-11	PLATE (FL), INDICATION	
105	4-945-420-01	PLATE (HP), INDICATION	
106	X-4942-604-1	PANEL (BASE) ASSY	
107	4-922-518-11	KNOB (TIMER)	
108	4-922-921-01	BUTTON (POWER)	
109	4-951-620-01	SCREW (2.6X8), +BVTP	
* 110	1-639-900-11	POWER SW BOARD	
* 111	A-4649-328-A	DSP BOARD, COMPLETE	
112	4-945-417-01	HOLDER (LED)	

Ref. No.	Part No.	Description	Remark
113	4-944-154-01	KNOB (DSP)	
114	3-354-981-01	SPRING (SUS), RING	
115	1-590-868-11	WIRE, FLAT TYPE	
* 116	A-4649-313-A	DISPLAY BOARD, COMPLETE	
117	1-590-867-11	WIRE, FLAT TYPE	
* 118	4-945-419-01	HOLDER (FL)	
* 119	1-639-899-11	KEY BOARD	
120	A 4604-901 A	KNOB (HP) ASSY	
* 121	1-639-902-11	HEADPHONE JACK BOARD	
* 122	1-639-901-11	VR BOARD	
123	A-4660-121-A	PANEL ASSY, FRONT (US, Canadian)	
124	4-948-469-01	SPRING, RING	
FL801	1-519-714-11	INDICATOR TUBE, FLUORESCENT	

5-4. CHASSIS BLOCK

The components identified by mark Δ or dotted line with mark Δ are critical for safety. Replace only with part number specified.

Les composants identifiés par une marque Δ sont critiques pour la sécurité. Ne les remplacer que par une pièce portant le numéro spécifié.

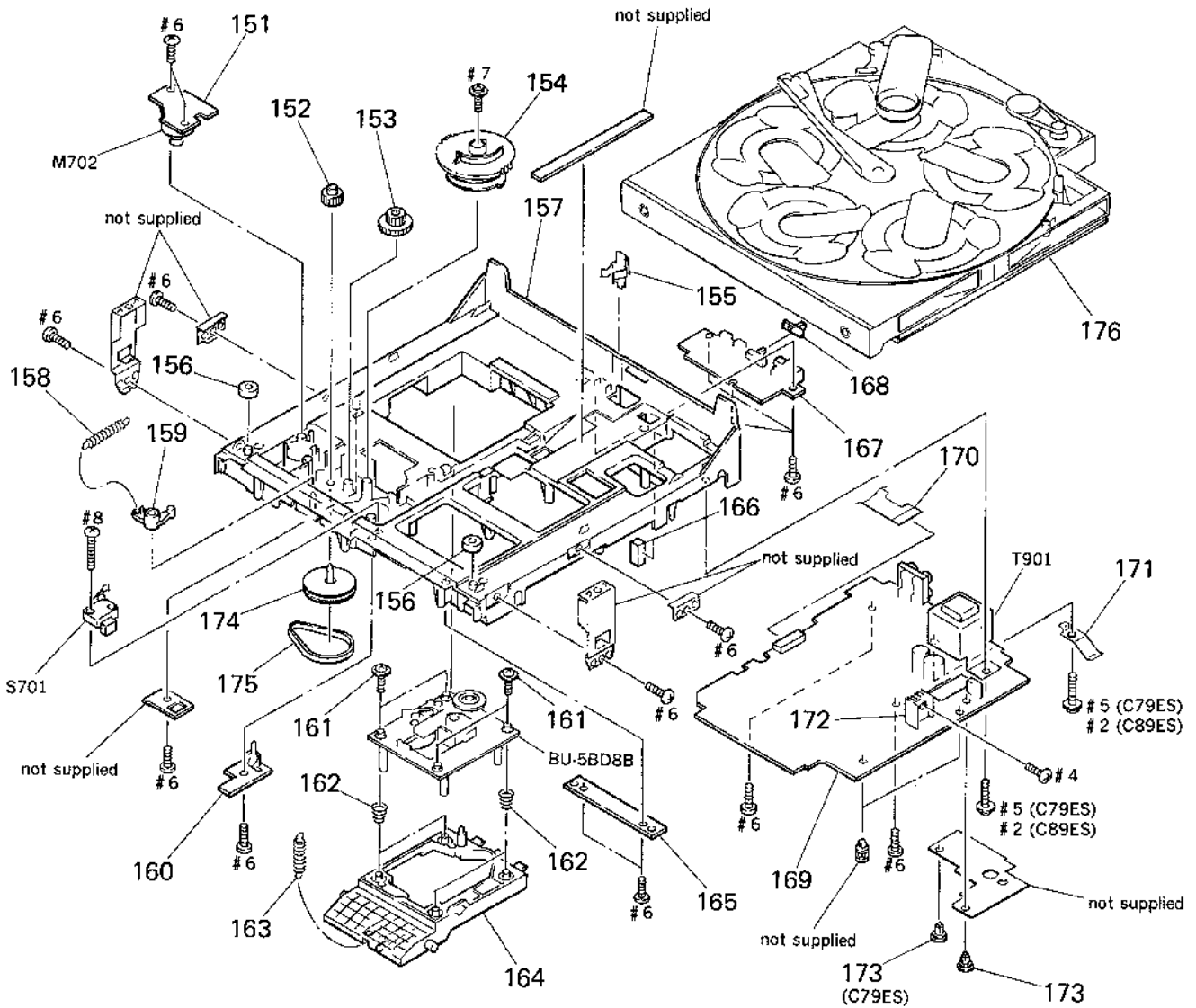

Ref. No.	Part No.	Description	Remark
* 151	1-638-730-11	LOADING MOTOR BOARD	
152	4-934-375-01	GEAR (LOADING B)	
153	4-934-381-01	GEAR (LOADING C)	
154	4-934-391-01	GEAR (LOADING A)	
* 155	4-943-996-01	SPRING, LEAF	
* 156	4-951-619 01	CUSHION (A)	
+ 157	4-943-997-01	CHASSIS	
158	4-924-412-01	SPRING (B), TENSION	
159	4-917-519-01	LEVER, SET	
+ 160	1-638-731-11	OPEN/CP SW BOARD	
161	4-933-134-01	SCREW (+PTPHW M2.6X6)	
162	4-949-385-01	SPRING (D), COIL	
163	4-937-911-01	SPRING, TENSION	
* 164	4-934-373-01	BRACKET (BU)	
* 165	1-644-556-11	RELAY BOARD	
166	9-911-815-03	CUSHION (C89ES)	
+ 167	A-4617-872-A	CHAIN BOARD, COMPLETE (C89ES)	
168	4-922-518-11	KNOB (TIMER)	

Ref. No.	Part No.	Description	Remark
* 169	A-4649-312-A	MAIN BOARD, COMPLETE (E)	
* 169	A-4649-314-A	MAIN BOARD, COMPLETE (C89ES)	
* 169	A-4649-316-A	MAIN BOARD, COMPLETE (C79ES;US,Canadian)	
* 169	A-4649-317-A	MAIN BOARD, COMPLETE (AEP)	
170	1-694-003-11	JAMPER, FILM (WITH TARMINAL)	
* 171	4-930-512-01	PLATE, GROUND	
* 172	4-363-146-00	HEAT SILK, V. OUT	
173	3-531-576-11	RIVET	
174	4-944-491-01	PULLEY (LOADING A)	
175	4-949-430-01	BELT (G RIB)	
176	A-4660-116-A	TRAY ASSY (C89ES)	
176	A-4660-122-A	TRAY ASSY (C79ES)	
M702	A-4604-871-A	MOTOR ASSY, LOADING	
S701	1-572-713-11	SWITCH, PUSH (WITH CONNECTOR) (DOWN)	
Δ T901	1-450-542-11	TRANSFORMER, POWER (US,Canadian)	
Δ T901	1-450-543-11	TRANSFORMER, POWER (AEP)	
Δ T901	1-450-544-11	TRANSFORMER, POWER (E)	

5-5. TRAY BLOCK

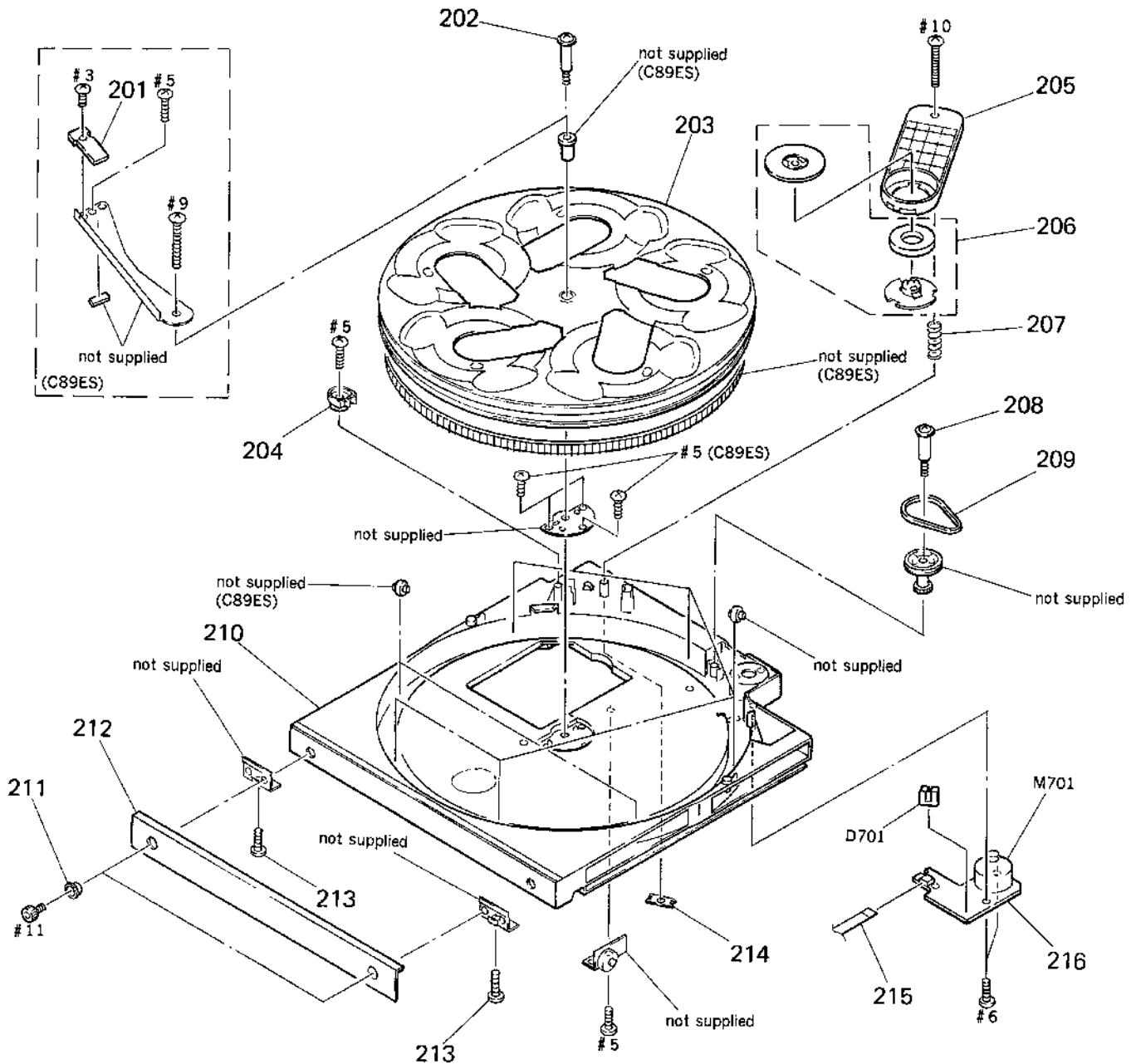

Ref. No.	Part No.	Description	Remark
* 201	1-644-769-12	DISK TABLE BOARD (C89ES)	
202	4-926-384-01	SCREW, STEP (C79ES)	
203	4-926-383-11	TABLE (B), DISK (C79ES)	
203	4-944-305-01	TABLE (B), DISK (C89ES)	
* 204	4-949-226-01	PLATE, LOCK	
* 205	4-930-506-02	BRACKET (PRESS PULLEY)	
* 206	1-452-538-11	MAGNET	
207	4-926-395-01	SPRING, COMPRESSION	
208	4-923-597-01	SCREW, STEP	
209	4-926-399-01	BELT	

Ref. No.	Part No.	Description	Remark
210	4-944-777-02	TABLE (A), DISC	
211	4-934-307-01	ESCUTCHEON	
212	4-944-779-21	PANEL (TABLE) (C89ES)	
212	4-944-779-31	PANEL (TABLE) (C79ES)	
213	4-928-635-01	SCREW, +BV (2.6X8) TAPPING	
* 214	4-926-388-01	BRACKET (ADJUSTMENT)	
215	1-590-849-11	WIRE, FLAT TYPE (5 CORE)	
* 216	1-638-729-11	TABLE MOTOR BOARD	
D701	8-719-970-19	DIODE GP-1A521	
M701	A-4604-585-A	MOTOR ASSY, ROTARY	

5-6. OPTICAL PICK-UP BLOCK (BU-5BD8B)

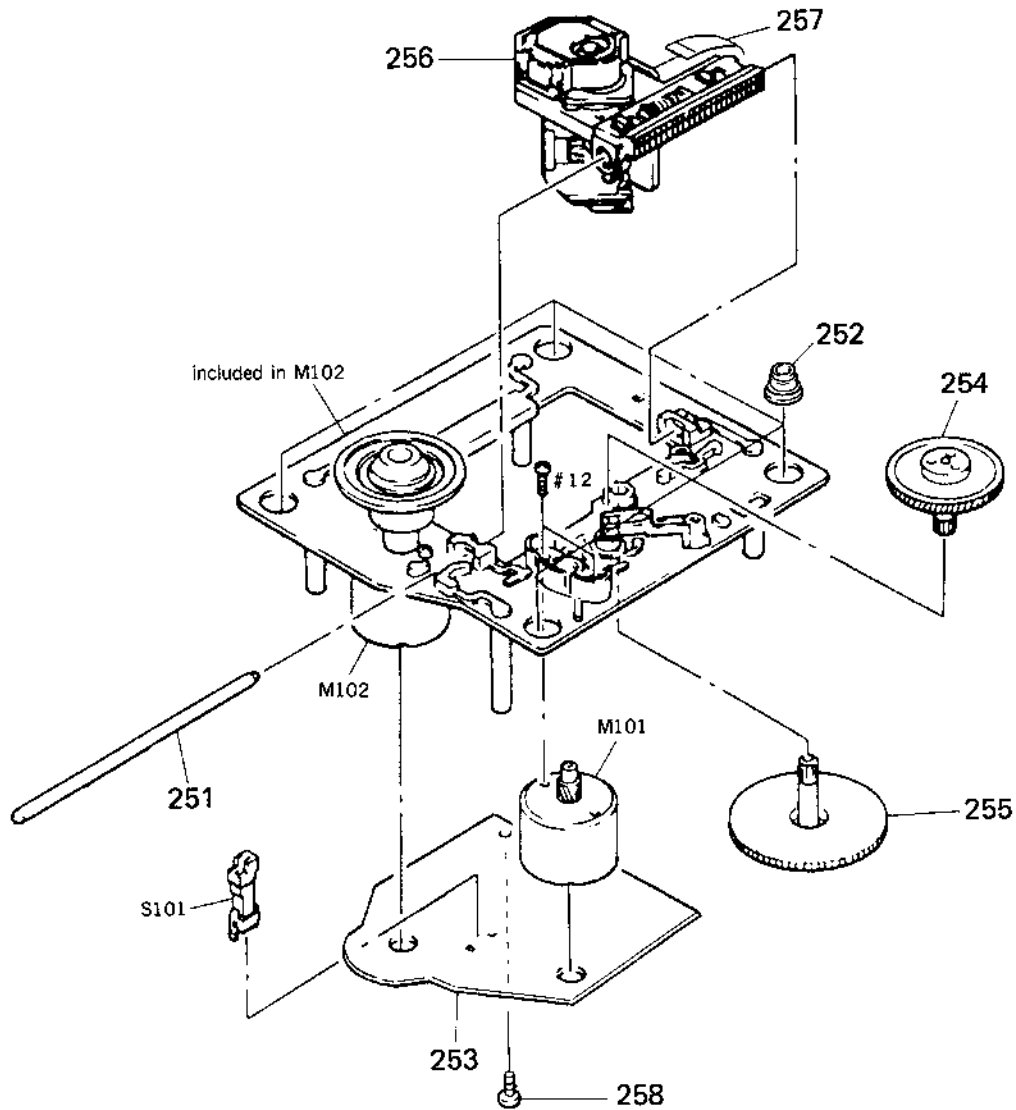

The components identified by mark \triangle or dotted line with mark \triangle are critical for safety. Replace only with part number specified.

Les composants identifiés par une marque \triangle sont critiques pour la sécurité. Ne les remplacer que par une pièce portant le numéro spécifié.

Ref. No.	Part No.	Description	Remark
251	4-917-565-01	SHAFT, SLED	
252	4-951-940-01	INSULATOR (BU)	
* 253	A-4649-199-A	BD BOARD, COMPLETE	
254	4-917-567-01	GEAR (M)	
255	4-917-564-01	GEAR (P), FLATNESS	

Ref. No.	Part No.	Description	Remark
\triangle 256	8-848-144-11	DEVICE, OPTICAL KSS-240A	
257	1-575-001-11	WIRE, FLAT TYPE (12 CORE)	
258	4-951-620-01	SCREW (2.6X8), +BVTP	
M101	X-4917-504-1	MOTOR ASSY, SLED	
M102	X-4917-523-3	MOTOR ASSY, SPINDLE	
S101	1-572-085-11	SWITCH, LEAF (LIMIT)	

SECTION 6 ELECTRICAL PARTS LIST

BD **CHAIN**

NOTE:

- Due to standardization, replacements in the parts list may be different from the parts specified in the diagrams or the components used on the set.
- -XX and -X mean standardized parts, so they may have some difference from the original one.
- RESISTORS
All resistors are in ohms.
METAL: Metal-film resistor.
METAL OXIDE: Metal oxide-film resistor.
F: nonflammable

- Items marked "*" are not stocked since they are seldom required for routine service. Some delay should be anticipated when ordering these items.
- SEMICONDUCTORS
In each case, u: μ , for example:
uA ... μ A. uPA... μ PA.
uPB... μ PB. uPC... μ PC. uPD... μ PD.
- CAPACITORS
uF: μ F
- COILS
uH: μ H

The components identified by mark Δ or dotted line with mark Δ are critical for safety. Replace only with part number specified.

Les composants identifiés par une marque Δ sont critiques pour la sécurité. Ne les remplacer que par une pièce portant le numéro spécifié.

When indicating parts by reference number, please include the board.

Ref. No.	Part No.	Description	Remark
*	A-4649-199-A	BD BOARD, COMPLETE *****	
		< CAPACITOR >	
C101	1-163-005-11	CERAMIC CHIP 470PF	10% 50V
C102	1-163-038-00	CERAMIC CHIP 0.1uF	25V
C103	1-163-005-11	CERAMIC CHIP 470PF	10% 50V
C104	1-164-505-11	CERAMIC CHIP 2.2uF	16V
C105	1-135-155-21	TANTALUM CHIP 4.7uF	10% 16V
C106	1-164-346-11	CERAMIC CHIP 1uF	16V
C107	1-164-505-11	CERAMIC CHIP 2.2uF	16V
C108	1-164-346-11	CERAMIC CHIP 1uF	16V
C112	1-163-038-00	CERAMIC CHIP 0.1uF	25V
C151	1-163-007-11	CERAMIC CHIP 680PF	10% 50V
C152	1-163-007-11	CERAMIC CHIP 680PF	10% 50V
C153	1-163-038-00	CERAMIC CHIP 0.1uF	25V
C154	1-164-336-11	CERAMIC CHIP 0.33uF	25V
C155	1-163-007-11	CERAMIC CHIP 680PF	10% 50V
C156	1-163-007-11	CERAMIC CHIP 680PF	10% 50V
C157	1-163-037-11	CERAMIC CHIP 0.022uF	10% 25V
C158	1-163-037-11	CERAMIC CHIP 0.022uF	10% 25V
C159	1-163-023-00	CERAMIC CHIP 0.015uF	5% 50V
C160	1-163-019-00	CERAMIC CHIP 0.005uF	10% 50V
C181	1-163-038-00	CERAMIC CHIP 0.1uF	25V
		< CONNECTOR >	
CN101	1-568-861-11	SOCKET, CONNECTOR 18P	
CN102	1-568-795-11	SOCKET, CONNECTOR 12P	
		< IC >	
IC101	8-752-344-48	IC CXD2501Q	
IC102	8-759-071-79	IC BA6297AFP	
		< RESISTOR >	
R101	1-216-077-00	METAL CHIP 15K 5%	1/10W
R102	1-216-097-00	METAL CHIP 100K 5%	1/10W
R103	1-216-077-00	METAL CHIP 15K 5%	1/10W
R104	1-216-085-00	METAL CHIP 33K 5%	1/10W
R105	1-216-097-00	METAL CHIP 100K 5%	1/10W

Ref. No.	Part No.	Description	Remark
R112	1-216-049-00	METAL CHIP 1K 5%	1/10W
R113	1-216-077-00	METAL CHIP 15K 5%	1/10W
R114	1-216-077-00	METAL CHIP 15K 5%	1/10W
R117	1-216-077-00	METAL CHIP 15K 5%	1/10W
R118	1-216-077-00	METAL CHIP 15K 5%	1/10W
R121	1-216-077-00	METAL CHIP 15K 5%	1/10W
R122	1-216-077-00	METAL CHIP 15K 5%	1/10W
R151	1-216-070-00	METAL CHIP 7.5K 5%	1/10W
R152	1-216-070-00	METAL CHIP 7.5K 5%	1/10W
R153	1-216-070-00	METAL CHIP 7.5K 5%	1/10W
R154	1-216-070-00	METAL CHIP 7.5K 5%	1/10W
R155	1-216-070-00	METAL CHIP 7.5K 5%	1/10W
R156	1-216-070-00	METAL CHIP 7.5K 5%	1/10W
R157	1-216-085-00	METAL CHIP 33K 5%	1/10W
R158	1-216-076-00	METAL CHIP 13K 5%	1/10W
R159	1-216-085-00	METAL CHIP 33K 5%	1/10W
R160	1-216-081-00	METAL CHIP 22K 5%	1/10W
R161	1-216-093-00	METAL CHIP 68K 5%	1/10W
R162	1-216-085-00	METAL CHIP 33K 5%	1/10W
R163	1-216-308-00	METAL CHIP 4.7 5%	1/10W
		< SWITCH >	
S101	1-572-085-11	SWITCH, LEAF (LIMIT)	

*	A-4617-872-A	CHAIN BOARD, COMPLETE (C89ES) *****	
		< CAPACITOR >	
C751	1-126-022-11	ELECT 47uF	20% 16V (C89ES)
C752	1-164-159-11	CERAMIC 0.1uF	50V (C89ES)
C755	1-130-467-00	MYLAR 470PF	5% 50V (C89ES)
C756	1-130-467-00	MYLAR 470PF	5% 50V (C89ES)
C757	1-136-165-00	FILM 0.1uF	5% 50V (C89ES)
C758	1-130-467-00	MYLAR 470PF	5% 50V (C89ES)
C759	1-130-467-00	MYLAR 470PF	5% 50V (C89ES)
C760	1-164-159-11	CERAMIC 0.1uF	50V (C89ES)
C761	1-164-159-11	CERAMIC 0.1uF	50V (C89ES)
C762	1-164-159-11	CERAMIC 0.1uF	50V (C89ES)
C763	1-162-294-31	CERAMIC 0.001uF	10% 50V (C89ES)

CHAIN

DISK TABLE

DISPLAY

DSP

Ref. No.	Part No.	Description	Remark
C764	1-164-159-11	CERAMIC 0.1uF	50V (C89ES)
		< CONNECTOR >	
* CN751	1-564-521-11	PLUG, CONNECTOR 6P (C89ES)	
* CN752	1-568-944-11	PIN, CONNECTOR 6P (C89ES)	
* CN753	1-564-518-11	PLUG, CONNECTOR 3P (C89ES)	
* CN754	1-566-859-11	SOCKET, CONNECTOR 15P (SERIAL CHAIN CONTROL) (C89ES)	
CN755	1-566-213-11	PIN, CONNECTOR 4P (CONTROL S IN) (C89ES)	
CN756	1-566-213-11	PIN, CONNECTOR 4P (CONTROL S OUT) (C89ES)	
		< DIODE >	
D751	8-719-987-63	DIODE 1N4148M (C89ES)	
D752	8-719-987-63	DIODE 1N4148M (C89ES)	
D753	8-719-987-63	DIODE 1N4148M (C89ES)	
D754	8-719-109-87	DIODE RD5.6ES-B (C89ES)	
D755	8-719-109-87	DIODE RD5.6ES-B (C89ES)	
D756	8-719-109-87	DIODE RD5.6ES-B (C89ES)	
D757	8-719-109-87	DIODE RD5.6ES-B (C89ES)	
D758	8-719-987-63	DIODE 1N4148M (C89ES)	
D759	8-719-987-63	DIODE 1N4148M (C89ES)	
		< IC >	
IC751	8-759-000-49	IC MC14066BCP (C89ES)	
		< RESISTOR >	
R751	1-249-433-11	CARBON 22K 5% 1/4W (C89ES)	
R752	1-249-433-11	CARBON 22K 5% 1/4W (C89ES)	
R753	1-249-433-11	CARBON 22K 5% 1/4W (C89ES)	
R754	1-249-409-11	CARBON 220 5% 1/4W (C89ES)	
R755	1-249-409-11	CARBON 220 5% 1/4W (C89ES)	
R756	1-249-409-11	CARBON 220 5% 1/4W (C89ES)	
R757	1-249-393-11	CARBON 10 5% 1/4W (C89ES)	
R758	1-249-429-11	CARBON 10K 5% 1/4W (C89ES)	
R759	1-249-429-11	CARBON 10K 5% 1/4W (C89ES)	
R760	1-249-393-11	CARBON 10 5% 1/4W (C89ES)	
R765	1-249-402-11	CARBON 56 5% 1/4W (C89ES)	
R766	1-249-402-11	CARBON 56 5% 1/4W (C89ES)	
R767	1-249-402-11	CARBON 56 5% 1/4W (C89ES)	
R768	1-249-402-11	CARBON 56 5% 1/4W (C89ES)	
		< SWITCH >	
S751	1-570-707-21	SWITCH, SLIDE (MODE) (C89ES)	

Ref. No.	Part No.	Description	Remark
	1-644-769-12	DISK TABLE BOARD (C89ES)	

		< CONNECTOR >	
* CN410	1-564-517-11	PLUG, CONNECTOR 2P (C89ES)	
		< RESISTOR >	
R999	1-249-417-11	CARBON 1K 5% 1/4W (C89ES)	

*	A-4649-131-A	DISPLAY BOARD, COMPLETE	

*	A-4649-328-A	DSP BOARD, COMPLETE	

	4-937-949-01	HOLDER, LED	
	4-945-417-01	HOLDER (LED)	
*	4-945-419-01	HOLDER (FL)	
		< CAPACITOR >	
C801	1-124-584-00	ELECT 100uF 20% 10V	
C802	1-164-159-11	CERAMIC 0.1uF 50V	
C803	1-164-159-11	CERAMIC 0.1uF 50V	
		< CONNECTOR >	
* CN801	1-568-865-11	SOCKET, CONNECTOR 23P	
* CN803	1-568-857-11	SOCKET, CONNECTOR 14P	
		< DIODE >	
D801	8-719-987-63	DIODE 1N4148M	
D802	8-719-987-63	DIODE N4148M	
D803	8-719-987-63	DIODE 1N4148M	
D804	8-719-987-63	DIODE 1N4148M	
D805	8-719-987-63	DIODE 1N4148M	
D806	8-719-987-63	DIODE 1N4148M	
D807	8-719-303-28	DIODE SEL1810A-C (H)	
D808	8-719-310-59	LED SEL1510C (P)	
D851	8-719-301-52	LED SEL2810A-C (HALL)	
D852	8-719-301-52	LED SEL2810A-C (CHURCH)	
D853	8-719-301-52	LED SEL2810A-C (JAZZ CLUB)	
D854	8-719-301-52	LED SEL2810A-C (STADIUM)	
D855	8-719-301-52	LED SEL2810A-C (DISCO)	
D856	8-719-301-52	LED SEL2810A-C (LIVE ROOM)	
D857	8-719-301-52	LED SEL2810A-C (BGM)	
		< FLUORESCENT INDICATOR >	
FL801	1-519-714-11	INDICATOR TUBE, FLUORESCENT	

DISPLAY

DSP

HEADPHONE JACK

KEY

POWER SW

VR

Ref. No.	Part No.	Description	Remark
< IC >			
IC801	8-759-067-11	IC MSC62408-042GS-V1K	
< TRANSISTOR >			
Q801	8-729-900-80	TRANSISTOR DTC114ES	
Q802	8-729-900-80	TRANSISTOR DTC114ES	
Q803	8-729-900-80	TRANSISTOR DTC114ES	
Q804	8-729-900-80	TRANSISTOR DTC114ES	
< RESISTOR >			
R801	1-249-425-11	CARBON 4.7K 5% 1/4W	
R802	1-249-429-11	CARBON 10K 5% 1/4W	
R803	1-247-903-00	CARBON 1M 5% 1/4W	
R804	1-249-441-11	CARBON 100K 5% 1/4W	
R805	1-249-441-11	CARBON 100K 5% 1/4W	
R806	1-249-412-11	CARBON 390 5% 1/4W	
R807	1-249-409-11	CARBON 220 5% 1/4W	
R808	1-249-417-11	CARBON 1K 5% 1/4W	
R809	1-249-429-11	CARBON 10K 5% 1/4W	
R810	1-249-429-11	CARBON 10K 5% 1/4W	
R811	1-249-429-11	CARBON 10K 5% 1/4W	
R812	1-249-429-11	CARBON 10K 5% 1/4W	
R850	1-249-425-11	CARBON 4.7K 5% 1/4W	
R851	1-249-434-11	CARBON 27K 5% 1/4W	
R852	1-249-430-11	CARBON 12K 5% 1/4W	
R853	1-247-850-11	CARBON 6.2K 5% 1/4W	
R854	1-247-844-11	CARBON 3.6K 5% 1/4W	
R855	1-247-838-00	CARBON 2K 5% 1/4W	
R856	1-249-416-11	CARBON 820 5% 1/4W	
R857	1-249-434-11	CARBON 27K 5% 1/4W	
R858	1-249-430-11	CARBON 12K 5% 1/4W	
R859	1-247-850-11	CARBON 6.2K 5% 1/4W	
R860	1-249-425-11	CARBON 4.7K 5% 1/4W	
R862	1-249-409-11	CARBON 220 5% 1/4W	
< VARIABLE RESISTOR >			
RV851	1-241-514-11	RES, VAR, CARBON 10K (EQUALIZER)	
RV852	1-241-514-11	RES, VAR, CARBON 10K (REVEB)	
< SWITCH >			
S801	1-554-303-21	SWITCH, TACTILE (▶)	
S802	1-554-303-21	SWITCH, TACTILE (■)	
S803	1-554-303-21	SWITCH, TACTILE (■)	
S804	1-554-303-21	SWITCH, TACTILE (◀)	
S805	1-554-303-21	SWITCH, TACTILE (▶)	
S806	1-554-303-21	SWITCH, TACTILE (◀◀)	
S807	1-554-303-21	SWITCH, TACTILE (▶▶)	
S808	1-554-303-21	SWITCH, TACTILE (OPEN/CLOSE)	

Ref. No.	Part No.	Description	Remark
S809	1-554-303-21	SWITCH, TACTILE (DISC SKIP)	
S851	1-554-303-21	SWITCH, TACTILE (HALL)	
S852	1-554-303-21	SWITCH, TACTILE (CHERCH)	
S853	1-554-303-21	SWITCH, TACTILE (JAZZ CLUB)	
S854	1-554-303-21	SWITCH, TACTILE (STADIUM)	
S855	1-554-303-21	SWITCH, TACTILE (DISCO)	
S856	1-554-303-21	SWITCH, TACTILE (FLAT)	
S857	1-554-303-21	SWITCH, TACTILE (LIVE ROOM)	
S858	1-554-303-21	SWITCH, TACTILE (BGM)	
S859	1-554-303-21	SWITCH, TACTILE (DSP FILE)	
< VIBRATOR >			
X801	1-577-358-21	VIBRATOR, CERAMIC (4MHz)	

*	1-639-902-11	HEADPHONE JACK BOARD	

*	1-639-899-11	KEY BOARD	

*	1-639-900-11	POWER SW BOARD	

*	1-639-901-11	VR BOARD	

< CAPACITOR >			
C841	1-162-290-31	CERAMIC 470PF 10% 50V	
C842	1-162-290-31	CERAMIC 470PF 10% 50V	
C843	1-164-159-11	CERAMIC 0.1uF 50V	
< CONNECTOR >			
* CN811	1-573-102-11	SOCKET, CONNECTOR 14P	
* CN843	1-564-518-11	PLUG, CONNECTOR 3P	
< IC >			
IC811	8-741-100-48	IC SBX1610-59	
< JACK >			
J841	1-568-519-41	JACK, LARGE TYPE (PHONES)	
< VARIABLE RESISTOR >			
RV840	1-241-513-11	RES, VAR, CARBON 10KX3 (LINE OUT PHONE LEVEL)	
< SWITCH >			
S811	1-554-303-21	SWITCH, TACTILE (DISC 1)	
S812	1-554-303-21	SWITCH, TACTILE (DISC 2)	
S813	1-554-303-21	SWITCH, TACTILE (DISC 3)	
S814	1-554-303-21	SWITCH, TACTILE (DISC 4)	
S815	1-554-303-21	SWITCH, TACTILE (DISC 5)	

HEADPHONE JACK

KEY

POWER SW

VR

LOADING MOTOR

TABLE MOTOR

OPEN/UP SW

MAIN

RELAY

Ref. No.	Part No.	Description	Remark	Ref. No.	Part No.	Description	Remark
S816	1-554-303-21	SWITCH, TACTILE (CONTINUE)				< RESISTOR >	
S817	1-554-303-21	SWITCH, TACTILE (SHUFFLE)					
S818	1-554-303-21	SWITCH, TACTILE (PROGRAM)		R701	1-249-416-11	CARBON 820 5% 1/4W	
S819	1-554-303-21	SWITCH, TACTILE (BANK)				< SWITCH >	
S820	1-554-303-21	SWITCH, TACTILE (TIME/MEMO)					
S821	1-572-714-11	SWITCH, PUSH (POWER)		S702	1-571-300-21	SWITCH, ROTARY (OPEN/UP)	
S822	1-570-157-51	SWITCH, SLIDE (TIMER)		*****			
S860	1-554-303-21	SWITCH, TACTILE (PEAK SEARCH)		*	A-4649-312-A	MAIN BOARD, COMPLETE (E)	
S861	1-554-303-21	SWITCH, TACTILE (FADER)		*	A-4649-314-A	MAIN BOARD, COMPLETE (C89ES)	
S862	1-554-303-21	SWITCH, TACTILE (CLEAR)		*	A-4649-316-A	MAIN BOARD, COMPLETE (C79ES:US, Canadian)	
				*	A-4649-317-A	MAIN BOARD, COMPLETE (AEP)	
S863	1-554-303-21	SWITCH, TACTILE (CHECK)				*****	
S864	1-554-303-21	SWITCH, TACTILE (MUSIC SCAN)		*	1-644-556-11	RELAY BOARD	
S865	1-554-303-21	SWITCH, TACTILE (REPEAT)				*****	
S866	1-554-303-21	SWITCH, TACTILE (5)					
S867	1-554-303-21	SWITCH, TACTILE (4)					
S868	1-554-303-21	SWITCH, TACTILE (3)					
S869	1-554-303-21	SWITCH, TACTILE (2)		*	4-352-844-01	PIN, LEAD, COATING	
S870	1-554-303-21	SWITCH, TACTILE (>10)			4-363-146-00	HEAT SINK, V. OUT	
S871	1-554-303-21	SWITCH, TACTILE (1)			7-682-547-09	SCREW +BVTT 3X6 (S)	
S872	1-554-303-21	SWITCH, TACTILE (EDIT/TIME FADE)			8-759-981-85	IC RC4556D	
						< CAPACITOR >	
S873	1-554-303-21	SWITCH, TACTILE (10)		C201	1-124-572-11	ELECT 100uF 20% 63V	
S874	1-554-303-21	SWITCH, TACTILE (9)		C202	1-126-163-11	ELECT 4.7uF 20% 50V	
S875	1-554-303-21	SWITCH, TACTILE (8)		C203	1-124-556-11	ELECT 2200uF 20% 16V	
S876	1-554-303-21	SWITCH, TACTILE (6)		C204	1-126-937-11	ELECT 4700uF 20% 16V	
S877	1-554-303-21	SWITCH, TACTILE (FILE)		C205	1-126-163-11	ELECT 4.7uF 20% 50V	
S878	1-554-303-21	SWITCH, TACTILE (LEVEL FILE)		C206	1-126-059-11	ELECT 10uF 20% 50V	
S879	1-554-303-21	SWITCH, TACTILE (7)		C207	1-126-059-11	ELECT 10uF 20% 50V	
S880	1-554-303-21	SWITCH, TACTILE (ERASE)		C208	1-126-022-11	ELECT 47uF 20% 16V	
*****				C210	1-126-101-11	ELECT 100uF 20% 16V	
*	1-638-730-11	LOADING MOTOR BOARD		C211	1-124-471-00	ELECT 1000uF 20% 6.3V	
		*****		C215	1-126-101-11	ELECT 100uF 20% 16V	
*	1-638-729-11	TABLE MOTOR BOARD		C216	1-126-024-11	ELECT 220uF 20% 16V	
		*****		C217	1-126-024-11	ELECT 220uF 20% 16V	
*	1-638-731-11	OPEN/UP SW BOARD		C218	1-124-120-11	ELECT 220uF 20% 25V	
		*****		C219	1-124-120-11	ELECT 220uF 20% 25V	
		< CAPACITOR >		C220	1-126-300-11	ELECT 0.47uF 20% 50V	
C704	1-161-375-00	CERAMIC 0.0022uF 20% 50V		C221	1-162-306-11	CERAMIC 0.01uF 20% 16V	
C705	1-161-375-00	CERAMIC 0.0022uF 20% 50V		C222	1-126-022-11	ELECT 47uF 20% 16V	
		< CONNECTOR >		C300	1-164-159-11	CERAMIC 0.1uF 50V	
CN705	1-573-383-11	PIN, CONNECTOR (PC BOARD) 2P		C301	1-124-589-11	ELECT 47uF 20% 16V	
* CN707	1-573-044-11	SOCKET, CONNECTOR 5P		C302	1-162-306-11	CERAMIC 0.01uF 20% 16V	
		< DIODE >		C309	1-126-022-11	ELECT 47uF 20% 16V	
D701	8-719-970-19	DIODE GP1A521		C310	1-164-159-11	CERAMIC 0.1uF 50V	
				C311	1-136-161-00	FILM 0.047uF 5% 50V	
				C312	1-161-374-11	CERAMIC 0.0015uF 20% 50V	
				C313	1-164-159-11	CERAMIC 0.1uF 50V	
				C314	1-162-306-11	CERAMIC 0.01uF 20% 16V	
				C315	1-126-300-11	ELECT 0.47uF 20% 50V	
				C316	1-164-159-11	CERAMIC 0.1uF 50V	

MAIN

RELAY

Ref. No.	Part No.	Description	Remark
C317	1-162-282-31	CERAMIC	100PF 10% 50V
C320	1-164-159-11	CERAMIC	0.1uF 50V
C321	1-162-306-11	CERAMIC	0.01uF 20% 16V
C323	1-164-159-11	CERAMIC	0.1uF 50V
C331	1-162-208-31	CERAMIC	24PF 5% 50V
C332	1-162-306-11	CERAMIC	0.01uF 20% 16V
C333	1-162-208-31	CERAMIC	24PF 5% 50V
C336	1-126-022-11	ELECT	47uF 20% 16V
C337	1-164-159-11	CERAMIC	0.1uF 50V
C341	1-164-159-11	CERAMIC	0.1uF 50V
C342	1-124-910-11	ELECT	47uF 20% 50V
C343	1-164-159-11	CERAMIC	0.1uF 50V
C345	1-164-159-11	CERAMIC	0.1uF 50V
C346	1-164-159-11	CERAMIC	0.1uF 50V
C348	1-164-159-11	CERAMIC	0.1uF 50V
C349	1-124-910-11	ELECT	47uF 20% 50V
C351	1-164-159-11	CERAMIC	0.1uF 50V
C353	1-162-199-31	CERAMIC	10PF 5% 50V
C354	1-162-199-31	CERAMIC	10PF 5% 50V
C356	1-124-910-11	ELECT	47uF 20% 50V
C357	1-124-910-11	ELECT	47uF 20% 50V
C358	1-164-159-11	CERAMIC	0.1uF 50V
C361	1-130-467-00	MYLAR	470PF 5% 50V
C363	1-136-437-11	FILM (US, Canadian, E)	220PF 5% 630V
C363	1-136-810-11	FILM	220PF 5% 100V (AEP)
C364	1-136-437-11	FILM (US, Canadian, E)	220PF 5% 630V
C364	1-136-810-11	FILM	220PF 5% 100V (AEP)
C365	1-136-437-11	FILM (US, Canadian, E)	220PF 5% 630V
C365	1-136-810-11	FILM	220PF 5% 100V (AEP)
C366	1-136-437-11	FILM (US, Canadian, E)	220PF 5% 630V
C366	1-136-810-11	FILM	220PF 5% 100V (AEP)
C367	1-130-467-00	MYLAR	470PF 5% 50V
C371	1-106-359-00	MYLAR	4700PF 5% 200V
C372	1-106-359-00	MYLAR	4700PF 5% 200V
C373	1-130-472-00	MYLAR	0.0012uF 5% 50V
C374	1-130-472-00	MYLAR	0.0012uF 5% 50V
C375	1-123-381-00	ELECT	2.2uF 20% 100V
C376	1-123-381-00	ELECT	2.2uF 20% 100V
C377	1-124-910-11	ELECT	47uF 20% 50V
C378	1-124-910-11	ELECT	47uF 20% 50V
C401	1-126-022-11	ELECT	47uF 20% 16V
C402	1-162-306-11	CERAMIC	0.01uF 20% 16V
C403	1-126-022-11	ELECT	47uF 20% 16V
C404	1-126-022-11	ELECT	47uF 20% 16V
C405	1-162-294-31	CERAMIC	0.001uF 10% 50V

Ref. No.	Part No.	Description	Remark
C406	1-162-294-31	CERAMIC	0.001uF 10% 50V
C407	1-162-294-31	CERAMIC	0.001uF 10% 50V
C408	1-164-159-11	CERAMIC	0.1uF 50V
C409	1-164-159-11	CERAMIC	0.1uF 50V
C410	1-164-159-11	CERAMIC	0.1uF 50V
C411	1-125-486-11	DOUBLE LAYERS	0.22F 5.5V
C412	1-164-159-11	CERAMIC	0.1uF 50V
C413	1-162-306-11	CERAMIC	0.01uF 20% 16V
C451	1-162-306-11	CERAMIC	0.01uF 20% 16V
C520	1-162-306-11	CERAMIC	0.01uF 20% 16V
C571	1-126-024-11	ELECT	220uF 20% 16V
C572	1-126-024-11	ELECT	220uF 20% 16V
C601	1-162-306-11	CERAMIC (C79ES)	0.01uF 20% 16V
C602	1-164-159-11	CERAMIC	0.1uF 50V
C603	1-164-159-11	CERAMIC	0.1uF 50V
C900	1-164-159-11	CERAMIC	0.1uF 50V
C901	1-164-159-11	CERAMIC	0.1uF 50V
C902	1-126-022-11	ELECT	47uF 20% 16V
C903	1-164-159-11	CERAMIC	0.1uF 50V
C904	1-124-589-11	ELECT	47uF 20% 16V
C905	1-162-306-11	CERAMIC	0.01uF 20% 16V
C909	1-162-306-11	CERAMIC	0.01uF 20% 16V
C912	1-136-165-00	FILM	0.1uF 5% 50V
C913	1-136-165-00	FILM	0.1uF 5% 50V
C915	1-164-159-11	CERAMIC	0.1uF 50V
C941	1-107-210-00	MICA	22PF 5% 500V
C942	1-124-910-11	ELECT	47uF 20% 50V
C943	1-124-463-00	ELECT	0.1uF 20% 50V
C944	1-124-463-00	ELECT	0.1uF 20% 50V
C945	1-124-463-00	ELECT	0.1uF 20% 50V
C971	1-107-210-00	MICA	22PF 5% 500V
C972	1-124-910-11	ELECT	47uF 20% 50V
C973	1-124-463-00	ELECT	0.1uF 20% 50V
C974	1-124-463-00	ELECT	0.1uF 20% 50V
C975	1-124-463-00	ELECT	0.1uF 20% 50V
C992	1-124-589-11	ELECT	47uF 20% 16V
< CONNECTOR >			
* CN201	1-580-230-11	PIN, CONNECTOR (PC BOARD)	3P
* CN301	1-691-895-21	CONNECTOR, FFC/FPC	18P
* CN401	1-568-839-11	SOCKET, CONNECTOR	23P
* CN403	1-568-824-11	SOCKET, CONNECTOR	5P
* CN404	1-568-943-11	PIN, CONNECTOR	5P
* CN501	1-564-708-11	PIN, CONNECTOR (SMALL TYPE)	6P
* CN502	1-564-506-11	PLUG, CONNECTOR	3P
CN601	1-566-213-11	PIN, CONNECTOR 4P (CONTROL S IN)	(C79ES)
* CN602	1-564-506-11	PLUG, CONNECTOR	3P (C89ES)
* CN831	1-568-937-11	PIN, CONNECTOR	10P

MAIN

RELAY

Ref. No.	Part No.	Description	Remark
* CN832	1-568-937-11	PIN, CONNECTOR 10P	
* CN901	1-568-946-11	PIN, CONNECTOR 8P	
* CN902	1-568-944-11	PIN, CONNECTOR 6P	
* CN903	1-568-955-11	PIN, CONNECTOR 6P	
* CN905	1-568-955-11	PIN, CONNECTOR 6P (C89ES)	
* CN906	1-564-509-11	PLUG, CONNECTOR 6P (C89ES)	
< DIODE >			
D201	8-719-200-82	DIODE 11ES2	
D202	8-719-109 87	DIODE RD5.6ES-B	
D203	8-719-200-82	DIODE 11ES2	
D204	8-719-200-82	DIODE 11ES2	
D205	8-719-200-82	DIODE 11ES2	
D206	8-719-200-82	DIODE 11ES2	
D208	8-719-109-85	DIODE RD5.1ES-B2	
D209	8-719-987-63	DIODE 1N4148M	
D211	8-719-200-82	DIODE 11ES2	
D212	8-719-200-82	DIODE 11ES2	
D213	8-719-987-63	DIODE 1N4148M	
D214	8-719-987-63	DIODE 1N4148M	
D341	8-719-921-63	DIODE RD7.5ES-B (C89ES)	
D351	8-719-987-63	DIODE 1N4148M	
D401	8-719-987-63	DIODE 1N4148M	
D571	8-719-987-63	DIODE 1N4148M (C89ES)	
D601	8-719-987-63	DIODE 1N4148M (C79ES)	
D602	8-719-987-63	DIODE 1N4148M (C79ES)	
D603	8-719-109-87	DIODE RD5.6ES-B (C79ES)	
D902	8-719-987-63	DIODE 1N4148M (C89ES)	
< GROUND PLATE >			
EB201	4-870-539-00	PLATE, GROUND	
< IC >			
IC201	8-759-605-43	IC M5231TL	
IC202	8-759-630-21	IC M5290P-16	
IC203	8-759-900-72	IC NE5532P	
IC204	8-759-604-86	IC M5F7807L	
IC205	8-759-708-12	IC NJM78L12A	
IC206	8-759-700-69	IC NJM79L12A	
IC301	8-752-337-26	IC CXD2500AQ	
IC302	8-752-342-65	IC CXD2560M	
IC303	8-759-044-10	IC CXD2562Q	
IC306	8-759-900-72	IC NE5532P	
IC307	8-759-900-72	IC NE5532P	
IC308	8-759-977-71	IC GP-1F31T	
IC401	8-759-065-76	IC μ PD75516GF-374-3B9 (C79ES)	
IC401	8-759-065-75	IC μ PD75516GF-373-3B9 (C89ES)	
IC402	8-759-512-81	IC LH5160N-10L	

Ref. No.	Part No.	Description	Remark
IC403	8-759-821-32	IC CXA1291P	
IC571	8-759-745-56	IC RC4556D	
IC901	8-752-341-99	IC CXD2701Q	
IC902	8-759-508-41	IC MS51464-10NC	
IC903	8-759-065-83	IC M37470M4-089SP	
IC904	8-759-917-18	IC SN74HCU04AN	
IC910	8-759-900-72	IC NE5532P	
< JACK >			
J381	1-568-760-11	JACK, PIN 4P (LINE OUT)	
< COIL >			
Δ L201	1-421-915-11	COIL, LINE FILTER	
L331	1-408-403-00	INDUCTOR 3.3uH	
L341	1-412-473-21	INDUCTOR 0uH	
L343	1-412-473-21	INDUCTOR 0uH	
L345	1-412-473-21	INDUCTOR 0uH	
L346	1-412-473-21	INDUCTOR 0uH	
L348	1-412-473-21	INDUCTOR 0uH	
L358	1-412-473-21	INDUCTOR 0uH	
L902	1-412-473-21	INDUCTOR 0uH	
L903	1-412-473-21	INDUCTOR 0uH	
L904	1-408-403-00	INDUCTOR 3.3uH	
< IC LINK >			
Δ PS201	1-532-685-00	LINK, IC (AEP, E)	
Δ PS202	1-532-637-00	LINK, IC 1.0A (AEP, E)	
< TRANSISTOR >			
Q201	8-729-900-89	TRANSISTOR DTC144ES	
Q203	8-729-141-83	TRANSISTOR 2SB1094-LK	
Q204	8-729-900-61	TRANSISTOR DTA114ES	
Q205	8-729-900-89	TRANSISTOR DTC144ES	
Q206	8-729-900-89	TRANSISTOR DTC144ES	
Q341	8-729-900-61	TRANSISTOR DTA114ES	
Q342	8-729-900-61	TRANSISTOR DTA114ES	
Q343	8-729-900-65	TRANSISTOR DTA144ES	
Q344	8-729-201-53	TRANSISTOR 2SA1015-GR (C89ES)	
Q345	8-729-900-89	TRANSISTOR DTC144ES	
Q346	8-729-201-53	TRANSISTOR 2SA1015-GR (C89ES)	
Q371	8-729-141-26	TRANSISTOR 2SC3622A-LK	
Q372	8-729-141-26	TRANSISTOR 2SC3622A-LK	
Q373	8-729-141-26	TRANSISTOR 2SC3622A-LK	
Q374	8-729-141-26	TRANSISTOR 2SC3622A-LK	
Q375	8-729-231-55	TRANSISTOR 2SC2878-AB	
Q376	8-729-231-55	TRANSISTOR 2SC2878-AB	
Q573	8-729-201-53	TRANSISTOR 2SA1015-GR (C89ES)	
Q574	8-729-201-52	TRANSISTOR 2SC1815-Y (C89ES)	

The components identified by mark Δ or dotted line with mark Δ are critical for safety. Replace only with part number specified.

Les composants identifiés par une marque Δ sont critiques pour la sécurité. Ne les remplacer que par une pièce portant le numéro spécifié.

MAIN **RELAY**

Ref. No.	Part No.	Description	Remark
Q575	8-729-900-85	TRANSISTOR DTC144WS (C89ES)	
Q576	8-729-900-65	TRANSISTOR DTA144ES (C89ES)	
Q577	8-729-900-65	TRANSISTOR DTA144ES (C89ES)	
Q601	8-729-900-89	TRANSISTOR DTC144ES	
Q602	8-729-900-61	TRANSISTOR DTA114ES	
Q603	8-729-900-61	TRANSISTOR DTA114ES	
Q604	8-729-900-61	TRANSISTOR DTA114ES	
Q901	8-729-900-63	TRANSISTOR DTA124ES	
Q902	8-729-900-63	TRANSISTOR DTA124ES	
Q903	8-729-900-63	TRANSISTOR DTA124ES	
Q941	8-729-231-55	TRANSISTOR 2SC2878-AB	
Q942	8-729-231-55	TRANSISTOR 2SC2878-AB	
Q943	8-729-231-55	TRANSISTOR 2SC2878-AB	
Q971	8-729-231-55	TRANSISTOR 2SC2878-AB	
Q972	8-729-231-55	TRANSISTOR 2SC2878-AB	
Q973	8-729-231-55	TRANSISTOR 2SC2878-AB	
		< RESISTOR >	
R201	1-249-429-11	CARBON 10K 5%	1/4W
R202	1-249-417-11	CARBON 1K 5%	1/4W
R205	1-249-425-11	CARBON 4.7K 5%	1/4W
R208	1-249-423-11	CARBON 3.3K 5%	1/4W
R209	1-249-413-11	CARBON 470 5%	1/4W
R210	1-249-429-11	CARBON 10K 5%	1/4W
R211	1-249-410-11	CARBON 270 5%	1/4W
R212	1-249-439-11	CARBON 68K 5%	1/4W
R213	1-249-423-11	CARBON 3.3K 5%	1/4W
R214	1-249-417-11	CARBON 1K 5%	1/4W
R215	1-249-409-11	CARBON 220 5%	1/4W
R220	1-249-425-11	CARBON 4.7K 5%	1/4W
R221	1-249-417-11	CARBON 1K 5%	1/4W (C89ES)
R305	1-249-411-11	CARBON 330 5%	1/4W
R311	1-249-423-11	CARBON 3.3K 5%	1/4W
R312	1-249-429-11	CARBON 10K 5%	1/4W
R313	1-249-423-11	CARBON 3.3K 5%	1/4W
R314	1-249-429-11	CARBON 10K 5%	1/4W
R315	1-249-405-11	CARBON 100 5%	1/4W
R316	1-247-903-00	CARBON 1M 5%	1/4W
R317	1-249-417-11	CARBON 1K 5%	1/4W
R318	1-249-441-11	CARBON 100K 5%	1/4W
R321	1-249-417-11	CARBON 1K 5%	1/4W
R322	1-249-417-11	CARBON 1K 5%	1/4W
R323	1-249-417-11	CARBON 1K 5%	1/4W
R324	1-249-417-11	CARBON 1K 5%	1/4W
R330	1-249-417-11	CARBON 1K 5%	1/4W
R331	1-249-417-11	CARBON 1K 5%	1/4W
R332	1-247-887-00	CARBON 220K 5%	1/4W
R342	1-249-417-11	CARBON 1K 5%	1/4W

Ref. No.	Part No.	Description	Remark
R343	1-249-441-11	CARBON 100K 5%	1/4W
R344	1-249-441-11	CARBON 100K 5%	1/4W
R345	1-249-425-11	CARBON 4.7K 5%	1/4W
R346	1-249-425-11	CARBON 4.7K 5%	1/4W
R347	1-249-441-11	CARBON 100K 5%	1/4W
R348	1-249-429-11	CARBON 10K 5%	1/4W (C89ES)
R349	1-249-417-11	CARBON 1K 5%	1/4W
R350	1-249-425-11	CARBON 4.7K 5%	1/4W (C89ES)
R351	1-249-428-11	CARBON 8.2K 5%	1/4W
R352	1-249-428-11	CARBON 8.2K 5%	1/4W
R353	1-249-428-11	CARBON 8.2K 5%	1/4W
R354	1-249-428-11	CARBON 8.2K 5%	1/4W
R355	1-249-428-11	CARBON 8.2K 5%	1/4W
R356	1-249-428-11	CARBON 8.2K 5%	1/4W
R357	1-249-428-11	CARBON 8.2K 5%	1/4W
R358	1-249-428-11	CARBON 8.2K 5%	1/4W
R359	1-247-846-11	CARBON 5.1K 5%	1/4W
R361	1-247-846-11	CARBON 4.3K 5%	1/4W
R362	1-247-846-11	CARBON 4.3K 5%	1/4W
R363	1-247-846-11	CARBON 4.3K 5%	1/4W
R364	1-247-846-11	CARBON 4.3K 5%	1/4W
R365	1-249-429-11	CARBON 10K 5%	1/4W
R366	1-249-429-11	CARBON 10K 5%	1/4W
R367	1-249-429-11	CARBON 10K 5%	1/4W
R368	1-249-429-11	CARBON 10K 5%	1/4W
R369	1-249-419-11	CARBON 1.5K 5%	1/4W
R370	1-249-419-11	CARBON 1.5K 5%	1/4W
R371	1-249-419-11	CARBON 1.5K 5%	1/4W
R372	1-249-419-11	CARBON 1.5K 5%	1/4W
R373	1-247-891-00	CARBON 330K 5%	1/4W
R374	1-247-891-00	CARBON 330K 5%	1/4W
R375	1-249-409-11	CARBON 220 5%	1/4W
R376	1-249-409-11	CARBON 220 5%	1/4W
R377	1-249-409-11	CARBON 220 5%	1/4W
R378	1-249-409-11	CARBON 220 5%	1/4W
R379	1-249-421-11	CARBON 2.2K 5%	1/4W
R380	1-249-421-11	CARBON 2.2K 5%	1/4W
R381	1-249-425-11	CARBON 4.7K 5%	1/4W
R382	1-249-425-11	CARBON 4.7K 5%	1/4W
R383	1-249-413-11	CARBON 470 5%	1/4W
R384	1-249-413-11	CARBON 470 5%	1/4W
R385	1-249-393-11	CARBON 10 5%	1/4W
R386	1-249-393-11	CARBON 10 5%	1/4W
R389	1-249-413-11	CARBON 470 5%	1/4W
R390	1-249-413-11	CARBON 470 5%	1/4W
R401	1-249-411-11	CARBON 330 5%	1/4W
R402	1-249-399-11	CARBON 33 5%	1/4W
R403	1-249-417-11	CARBON 1K 5%	1/4W
R409	1-247-881-00	CARBON 120K 5%	1/4W (C79ES)

MAIN

RELAY

Ref. No.	Part No.	Description	Remark	Ref. No.	Part No.	Description	Remark
R409	1-247-882-11	CARBON	130K 5% 1/4W (C89ES)	R593	1-249-429-11	CARBON	10K 5% 1/4W (C89ES)
R410	1-247-881-00	CARBON	120K 5% 1/4W (C79ES)	R594	1-249-417-11	CARBON	1K 5% 1/4W (C89ES)
R410	1-247-882-11	CARBON	130K 5% 1/4W (C89ES)	R601	1-249-429-11	CARBON	10K 5% 1/4W
R411	1-249-441-11	CARBON	100K 5% 1/4W (C79ES)	R602	1-249-429-11	CARBON	10K 5% 1/4W
R411	1-247-880-11	CARBON	110K 5% 1/4W (C89ES)	R603	1-249-393-11	CARBON	10 5% 1/4W (C79ES)
R412	1-247-878-00	CARBON	91K 5% 1/4W (C79ES)	R901	1-249-417-11	CARBON	1K 5% 1/4W
R412	1-249-441-11	CARBON	100K 5% 1/4W (C89ES)	R902	1-249-417-11	CARBON	1K 5% 1/4W
R413	1-247-881-00	CARBON	120K 5% 1/4W	R903	1-249-417-11	CARBON	1K 5% 1/4W
R414	1-247-881-00	CARBON	120K 5% 1/4W	R905	1-249-417-11	CARBON	1K 5% 1/4W
R415	1-249-439-11	CARBON	68K 5% 1/4W (C79ES)	R906	1-249-417-11	CARBON	1K 5% 1/4W
R415	1-247-876-11	CARBON	75K 5% 1/4W (C89ES)	R907	1-249-417-11	CARBON	1K 5% 1/4W
R416	1-249-439-11	CARBON	68K 5% 1/4W (C79ES)	R910	1-249-429-11	CARBON	10K 5% 1/4W
R416	1-247-876-11	CARBON	75K 5% 1/4W (C89ES)	R911	1-249-417-11	CARBON	1K 5% 1/4W
R417	1-247-878-00	CARBON	91K 5% 1/4W	R912	1-249-417-11	CARBON	1K 5% 1/4W
R418	1-247-878-00	CARBON	91K 5% 1/4W	R913	1-249-417-11	CARBON	1K 5% 1/4W
R419	1-249-440-11	CARBON	82K 5% 1/4W	R915	1-249-441-11	CARBON	100K 5% 1/4W
R420	1-249-440-11	CARBON	82K 5% 1/4W	R916	1-249-441-11	CARBON	100K 5% 1/4W
R421	1-249-393-11	CARBON	10 5% 1/4W	R917	1-249-441-11	CARBON	100K 5% 1/4W
R422	1-249-393-11	CARBON	10 5% 1/4W	R924	1-249-417-11	CARBON	1K 5% 1/4W
R423	1-249-393-11	CARBON	10 5% 1/4W	R925	1-249-417-11	CARBON	1K 5% 1/4W
R450	1-249-429-11	CARBON	10K 5% 1/4W	R941	1-249-419-11	CARBON	1.5K 5% 1/4W
R451	1-249-429-11	CARBON	10K 5% 1/4W	R943	1-249-441-11	CARBON	100K 5% 1/4W
R452	1-249-429-11	CARBON	10K 5% 1/4W	R945	1-249-425-11	CARBON	4.7K 5% 1/4W
R453	1-249-429-11	CARBON	10K 5% 1/4W	R946	1-249-425-11	CARBON	4.7K 5% 1/4W
R454	1-249-429-11	CARBON	10K 5% 1/4W	R947	1-249-425-11	CARBON	4.7K 5% 1/4W
R456	1-249-429-11	CARBON	10K 5% 1/4W	R948	1-249-421-11	CARBON	2.2K 5% 1/4W
R457	1-249-429-11	CARBON	10K 5% 1/4W	R949	1-249-422-11	CARBON	2.7K 5% 1/4W
R458	1-249-429-11	CARBON	10K 5% 1/4W	R950	1-247-836-11	CARBON	1.6K 5% 1/4W
R459	1-249-429-11	CARBON	10K 5% 1/4W	R951	1-247-828-11	CARBON	750 5% 1/4W
R460	1-249-429-11	CARBON	10K 5% 1/4W	R952	1-247-832-11	CARBON	1.1K 5% 1/4W
R461	1-249-429-11	CARBON	10K 5% 1/4W	R953	1-249-410-11	CARBON	270 5% 1/4W
R462	1-249-429-11	CARBON	10K 5% 1/4W	R971	1-249-419-11	CARBON	1.5K 5% 1/4W
R463	1-249-429-11	CARBON	10K 5% 1/4W	R973	1-249-441-11	CARBON	100K 5% 1/4W
R464	1-249-429-11	CARBON	10K 5% 1/4W	R975	1-249-425-11	CARBON	4.7K 5% 1/4W
R465	1-249-429-11	CARBON	10K 5% 1/4W	R976	1-249-425-11	CARBON	4.7K 5% 1/4W
R571	1-249-405-11	CARBON	100 5% 1/4W	R977	1-249-425-11	CARBON	4.7K 5% 1/4W
R572	1-249-405-11	CARBON	100 5% 1/4W	R978	1-249-421-11	CARBON	2.2K 5% 1/4W
R573	1-249-434-11	CARBON	27K 5% 1/4W	R979	1-249-422-11	CARBON	2.7K 5% 1/4W
R574	1-249-437-11	CARBON	47K 5% 1/4W	R980	1-247-836-11	CARBON	1.6K 5% 1/4W
R575	1-249-437-11	CARBON	47K 5% 1/4W	R981	1-247-828-11	CARBON	750 5% 1/4W
R576	1-249-402-11	CARBON	56 5% 1/4W	R982	1-247-832-11	CARBON	1.1K 5% 1/4W
R578	1-247-881-00	CARBON	120K 5% 1/4W	R983	1-249-410-11	CARBON	270 5% 1/4W
R583	1-249-437-11	CARBON	47K 5% 1/4W				
R584	1-249-434-11	CARBON	27K 5% 1/4W			< RELAY >	
R585	1-249-437-11	CARBON	47K 5% 1/4W				
R586	1-249-402-11	CARBON	56 5% 1/4W	RY901	1-515-726-11	RELAY (C89ES)	
R589	1-247-881-00	CARBON	120K 5% 1/4W	RY902	1-515-726-11	RELAY (C89ES)	
R591	1-249-429-11	CARBON	10K 5% 1/4W (C89ES)				
R592	1-249-417-11	CARBON	1K 5% 1/4W (C89ES)				

MAIN **RELAY**

Ref. No.	Part No.	Description	Remark
		< SWITCH >	
△S201	1-571-722-11	SWITCH, VOLTAGE SELECTION (VOLTAGE SELECTOR) (E)	
		< VIBRATOR >	
X351	1-579-161-11	VIBRATOR, CRYSTAL (45MHz)	
X401	1-577-359-21	VIBRATOR, CERAMIC (4.19MHz)	
X901	1-577-359-21	VIBRATOR, CERAMIC (3.15MHz)	

		MISCELLANEOUS	

△16	1-559-583-21	CORD, POWER	
△60	1-558-568-21	CORD, POWER (AEP)	
△61	1-558-181-21	CORD, POWER (E)	
△62	1-569-007-11	ADAPTER, CONVERSION 2P (E)	
△63	1-559-583-21	CORD, POWER (US, Canadian)	
115	1-590-868-11	WIRE, FLAT TYPE	
117	1-590-867-11	WIRE, FLAT TYPE	
170	1-694-003-11	JAMPER, FILM (WITH TERMINAL)	
* 206	1-452-538-11	MAGNET	
215	1-590-849-11	WIRE, FLAT TYPE (5 CORE)	
△256	8-848-144-11	DEVICE, OPTICAL KSS-240A	
257	1-575-001-11	WIRE, FLAT TYPE (12 CORE)	
M101	X-4917-504-1	MOTOR ASSY, SLED	
M102	X-4917-523-3	MOTOR ASSY, SPINDLE	
M701	A-4604-585-A	MOTOR ASSY, ROTARY	
M702	A-4604-871-A	MOTOR ASSY, LOADING	
S701	1-572-713-11	SWITCH, PUSH (WITH CONNECTOR) (DOWN)	
△T901	1-450-542-11	TRANSFORMER, POWER (US, Canadian)	
△T901	1-450-543-11	TRANSFORMER, POWER (AEP)	
△T901	1-450-544-11	TRANSFORMER, POWER (E)	

Ref. No.	Part No.	Description	Remark
		ACCESSORIES & PACKING MATERIALS	

	1-465-727-11	REMOTE COMMANDER (RM-D815) (C89ES)	
	1-465-728-11	REMOTE COMMANDER (RM-D715) (C79ES)	
	1-558-233-11	CORD (WITH CONNECTOR) (SIRCS)4P (C89ES)	
	1-558-271-11	CORD, CONNECTION	
	1-575-103-31	CORD (WITH CONNECTOR) (C89ES)	
	1-590-925-31	CORD, CONNECTION	
	3-704-366-01	SCREW (CASE) (M3X8)	
	3-707-584-01	COVER, BATTERY	
	3-755-064-11	MANUAL, INSTRUCTION (ENGLISH, FRENCH, SPANISH, PORTUGUESE) (Canadian, AEP, E)	
	3-755-064-21	MANUAL, INSTRUCTION (ENGLISH) (US)	
	3-755-064-41	MANUAL, INSTRUCTION (GERMAN, DUTCH, SWEDISH, ITALIAN) (AEP)	
*	4-934-320-01	CUSHION (FRONT)	
*	4-934-321-01	CUSHION (REAR)	
*	4-952-388-01	INDIVIDUAL CARTON (C79ES)	
*	4-952-388-11	INDIVIDUAL CARTON (C89ES)	

HARDWARE LIST

#1	7-682-247-09	SCREW +K 3X6
#2	7-685-648-79	SCREW +BVTP 3X12 TYPE2 N-S
#3	7-685-870-01	SCREW +BVTT 3X5 (S)
#4	7-682-547-09	SCREW +BV 3X6, S TIGHT
#5	7-685-647-79	SCREW, TAPPING
#6	7-685-646-79	SCREW +BVTP 3X8 TYPE2 N-S
#7	7-682-661-09	SCREW +PSW 4X8
#8	7-685-136-19	SCREW +P 2.6X12 TYPE2 NON SLIT
#9	7-685-666-79	SCREW +BVTP 4X30 TYPE2 N-S (C89ES)
#10	7-682-554-04	SCREW +B 3X25
#11	7-683-401-04	BOLT, HEXAGON SOCKET 3X4
#12	7-621-255-15	SCREW +P 2X3

The components identified by mark △ or dotted line with mark △ are critical for safety. Replace only with part number specified.	Les composants identifiés par une marque △ sont critiques pour la sécurité. Ne les remplacer que par une pièce portant le numéro spécifié.
--	--