

# *Compact Disc Player*

---

## **Operating Instructions**

Before operating the unit, please read this manual thoroughly and retain it for future reference.

## **Owner's Record**

The model and serial numbers are located at the rear. Record these numbers in the spaces provided below. Refer to these numbers whenever you call upon your Sony dealer regarding this product.

Model No. \_\_\_\_\_ Serial No. \_\_\_\_\_



*CDP-970  
CDP-508ESD*

# Warning

To prevent fire or shock hazard, do not expose the unit to rain or moisture.

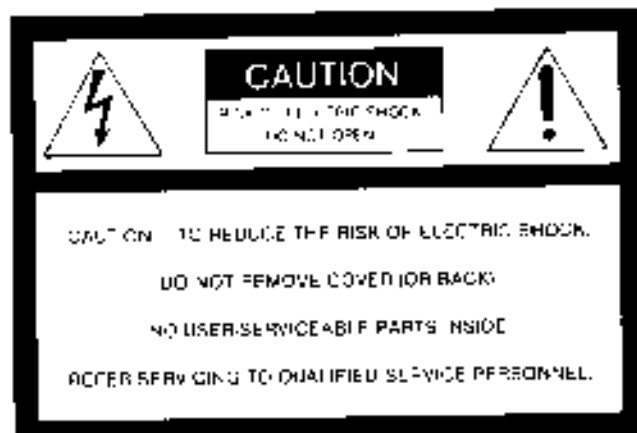

This symbol is intended to alert the user to the presence of uninsulated "dangerous voltage" within the product's enclosure that may be of sufficient magnitude to constitute a risk of electric shock to persons.



This symbol is intended to alert the user to the presence of important operating and maintenance (servicing) instructions in the literature accompanying the appliance.

## Difference between the CDP-970 and the CDP-508ESD

This manual covers the CDP-970 and the CDP-508ESD. Their performance and operation are identical except that for the CDP-508ESD, wood panels are attached on the sides. The illustrations used in this manual are of the CDP-970.

## INFORMATION

This equipment generates and uses radio frequency energy and if not installed and used properly, that is, in strict accordance with the manufacturer's instructions, may cause interference to radio and television reception. It has been type tested and found to comply with the limits for a Class B computing device in accordance with the specifications in Subpart J of Part 15 of FCC Rules, which are designed to provide reasonable protection against such interference in a residential installation. However, there is no guarantee that interference will not occur in a particular installation. If this equipment does cause interference to radio or television reception, which can be determined by turning the equipment off and on, the user is encouraged to try to correct the interference by one or more of the following measures:

- Reorient the receiving antenna.
- Relocate the equipment with respect to the receiver.
- Move the equipment away from the receiver.
- Plug the equipment into a different outlet so that equipment and receiver are on different branch circuits.

If necessary, the user should consult the dealer or an experienced radio/television technician for additional suggestions. The user may find the following booklet prepared by the Federal Communications Commission helpful:

"How to Identify and Resolve Radio-TV Interference Problems".

This booklet is available from the U.S. Government Printing Office, Washington, DC 20402. Stock No. 004-000-00345-4.

# Introducing This CD Player

## Enjoy listening in various playing modes

You can select the playing modes among the following:

- Continuous play (page 6)— The entire disc is played once.
- Single play (page 9) — One selection is played.
- Program play (page 12) — Selections are played in your desired order.
- Shuffle play (page 10) — Selections are played in a random order.
- Repeat play (page 11) — Selections or portion are played repeatedly.

## Editing your own tapes

- You can fade in or out the play when making your own tape recording.
  - Fade in/Fade out (page 16)
- CUSTOM EDIT function
  - You can confirm the total playing time while choosing the selections to be programmed.
    - Program edit (page 14)
  - The player can program selections automatically to fit in a desired duration -Time edit (page 15)
  - You can stop the play, fading out at the time desired.
    - Time fade (page 16)

## Making your disc custom-made — CUSTOM FILE function

- You can assign a name to a disc, such as the title of the disc or the date of purchase.
  - Disc memo (page 18)
- You can assign your own Index point to any desired position on a disc.
  - Custom index (page 20)
- You can store the programmed playing order for a disc.
  - Program bank (page 18)

## You can make a 3 seconds blank between selections

The blank space enables you to locate selections when using a tape deck with the automatic selection search function.

## Easy-to-see display

The selection number, the playing time, the remaining time are displayed by pressing the button. And also playing modes like repeat, shuffle, program are displayed in the display window.

# Table of Contents

## Introducing this CD player

### Location of controls

Front panel .....	4
Remote commander .....	4

### Connecting the CD player

### Preparing the remote commander

### Playing a disc

Locating a particular selection .....	8
Locating a particular point in a selection .....	8
Locating an index .....	8
Playing a single selection - Single play .....	9

### Playing in a random order - Shuffle play

### Playing repeatedly - Repeat play

Repeating selections .....	11
Repeating a particular portion - A > B repeat .....	11

### Playing in a desired order - Program play

### Designating the playing order

#### - Program edit

### Designating the total playing time

#### - Time edit

### Tips on editing tapes

Fading out at the desired time - Time fade .....	16
Fading in/Fading out .....	16
Inserting a blank space between selections - Auto space .....	16

### On Custom Files

### Keeping the Program in Memory

Memorizing a program .....	18
Playing the disc using the program bank .....	18
Cleaning the program bank .....	18

### Assigning names to a Disc

Cleaning the disc memo .....	19
------------------------------	----

### Giving a Disc indexes as you want

Playing from the desired custom index .....	20
Cleaning custom indexes .....	20
Repeating the portion between two custom indexes .....	20

### Timer activated playing

### Maintenance

Cleaning you unit .....	22
Cleaning disc .....	22

### Installing the CD player

Notes on installation .....	22
-----------------------------	----

### Specifications

### Troubleshooting guide



This indicates a function operated only from the remote commander.



This indicates a function operated only on the main unit.

# Location of Controls

## Front Panel

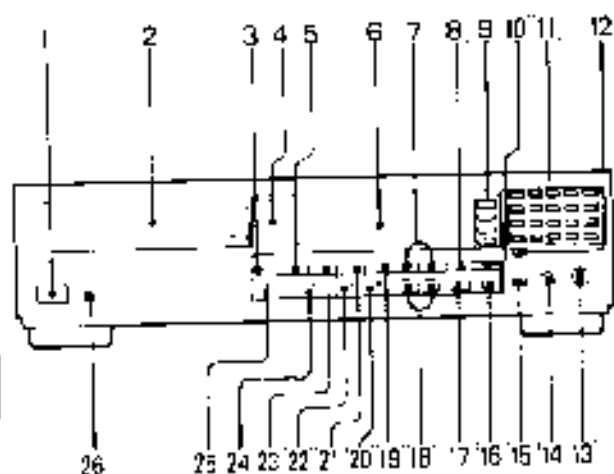

Refer to the pages indicated in ● for details.

- 1 POWER switch ●
- 2 Disc tray ●
- 3 TIME/MEMO button ●
- 4 Remote sensor
- 5 AUTO SPACE (auto space) button ●
- 6 Display window ●
- 7 ◀▶ (manual search) buttons ●
- 8 CHECK (program check) button ●
- 9 PLAY MODE buttons  
PROGRAM button ●  
SHUFFLE button ●  
CONTINUE/SINGLE button ●  
CUSTOM INDEX button ●
- 10 CLEAR (program clear) button ●
- 11 Numeric buttons ●
- 12 > 20 (over 20) button ●
- 13 LINE OUT/HEADPHONE LEVEL control ●
- 14 HEADPHONES jack ●
- 15 EDIT/TIME FADE button ●
- 16 ERASE (memory erase) button ●
- 17 FILE (custom file) button ●
- 18 ◀▶ (AMS\*) buttons ●
- 19 FILE RECALL button ●
- 20 ■ (stop) button ●
- 21 FADER (FADE IN/FADE OUT) button ●
- 22 || (pause) button ●
- 23 REPEAT button ●
- 24 ▶ (play) button ●
- 25 ▲ (open/close) button ●
- 26 Timer switch ●

\* AMS is the abbreviation of Automatic Music Sensor

## Remote Commander

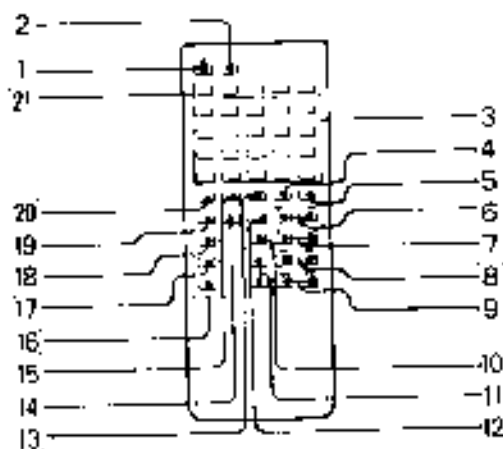

Refer to the pages indicated in ● for details

- 1 ▲ (open/close) button ●
- 2 FILE RECALL button ●
- 3 Numeric buttons ●
- 4 ERASE button ●
- 5 FILE (custom file) button ●
- 6 ◀▶ AMS buttons ●
- 7 ▲ ▲ INDEX buttons ●
- 8 ◀▶ (manual search) buttons ●
- 9 ◀▶ SLOW (low speed manual search) buttons ●
- 10 FADER (FADE IN/FADE OUT) button ●
- 11 LINE OUT VOLUME (line out/headphone volume) buttons ●
- 12 TIME button ●
- 13 CLEAR (program clear) button ●
- 14 A + B repeat button ●
- 15 CHECK button ●
- 16 ■ (stop) button ●
- 17 || (pause) button ●
- 18 ▶ (play) button ●
- 19 CLEAR/REPEAT (A + B repeat clear/repeat) button ●
- 20 > 20 (over 20) button ●
- 21 PLAY MODE buttons  
PGM (program) button ●  
SHUFFLE button ●  
CONTINUE button ●  
SINGLE button ●  
C.INDEX button ●

# Connecting the CD Player

You can enjoy the unit with analog or digital signal depending on your amplifier or D/A converter.

## Notes on Connection

- Turn off the power of each unit before making connections.
- Connect the AC power cord last.
- Be sure to insert the plugs firmly into the jacks. Loose connection may cause hum and noise.
- Leave a little slack in the connecting cord to allow for inadvertent shock or vibration.
- Cord plugs and jacks are color coded: Red plugs and jacks are for the right channel (R) and white ones for the left channel (L).

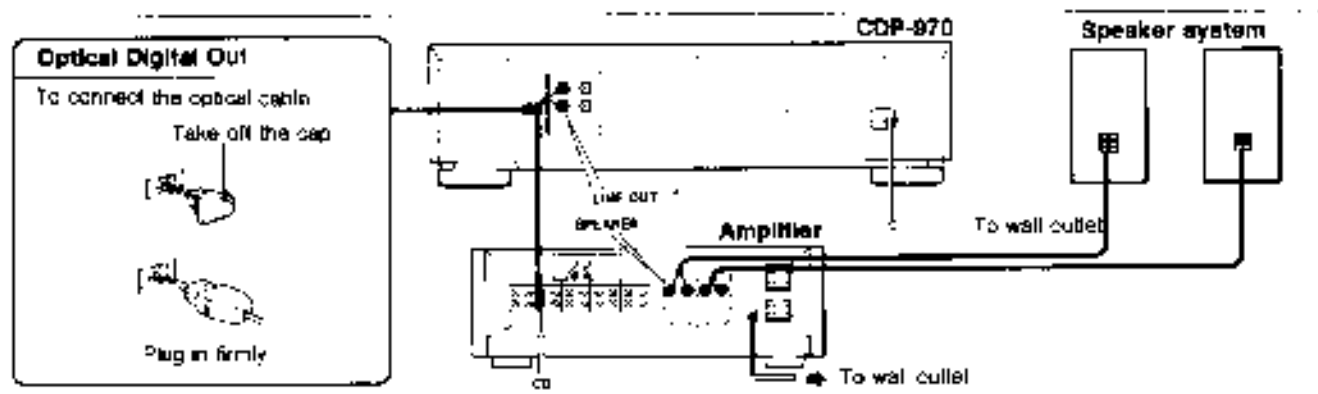

### Note on optical digital out

Connect the optical out to the amplifier with the optical input or D/A converter. When you connect, use the connecting cable for optical out POC-15 (optional). When the optical out is connected, you cannot use fade out, fade in and time fade function.

### When you use the VARIABLE LINE OUT

Output level can be adjusted with the LINE OUT/PHONE LEVEL control. If the LINE OUT/PHONE LEVEL control is tuned while recording, the recording level will change even though it is preset on the tape deck.

### Note on FIXED and VARIABLE LINE OUT

Normally connect the cable to FIXED. When you connect the unit to a power amplifier, connect the cable to VARIABLE and control the volume with LINE OUT/PHONE LEVEL control. Also when you connect the unit to the pre-amplifier, connect the cable to VARIABLE. You can adjust the volume easily. You can control the volume with the remote commander when you use the headphones or connect the cable to VARIABLE.

# Preparing the Remote Commander

## Installing Batteries

1



2

two size AA R6J batteries

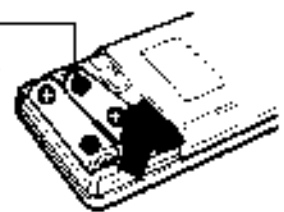

### On battery life

- About half a year of normal operation can be expected when using the Sony SJM-9(NS) batteries.
- When the batteries are run down, the remote commander will not operate the unit. In this case, replace both batteries with new ones.

### Notes on the remote commander and remote control operation

- Keep the commander away from extremely hot or humid places.
- Avoid dropping any foreign objects into the commander casing, particularly when replacing the batteries.
- Avoid exposing the remote sensor to direct sunlight or lighting apparatus. Such exposure can cause a malfunction.
- To avoid damage caused by battery leakage and corrosion, remove the batteries when the commander will not be used for a long time.

# Playing a Disc

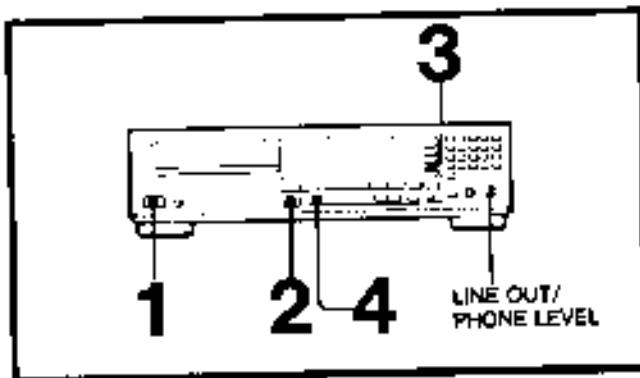

1

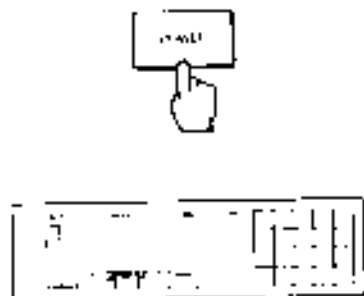

2

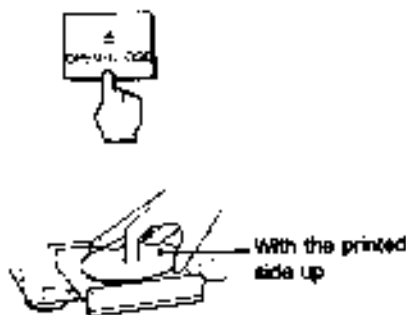

3

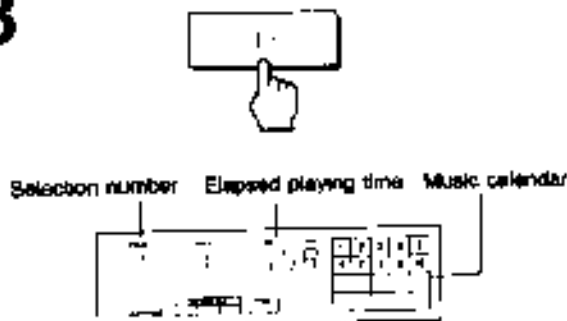

## To stop play

To stop for a moment during play, press **II**.

Press again to resume play.

To stop play, press **■**.

To stop play and open the tray, press **▲**.

## When using with the stereo system

Turn on the amplifier, and select "CD" of the input selector to listen to the compact disc player.

## To control the volume

When you use VARIABLE, control the volume with the LINE OUT/PHONE LEVEL control of the player or LINE OUT VOLUME of the remote commander. Press + of the remote commander to turn up the volume and press - to turn down the volume. When you press + or -, the LINE OUT/PHONE LEVEL control of the player rotates automatically.

### Caution on adjusting volume

Do not turn up the volume while listening to a portion with very low level inputs or no audio signals. If you do the speakers may be damaged when a peak level portion is played.

## When listening with headphones

Connect the headphones and control the volume with the LINE OUT/PHONE LEVEL control or LINE OUT VOLUME of the remote commander.

## If a disc contains more than 20 selections

**MEMO** appears in the display window instead of the total number of selections.

## What is this indication?

DISC/MEMO

This indication appears when there is no disc in the disc compartment.

## To play a 3-inch (8 cm) CD

Place it on the inner circle of the tray. If the disc is provided with an adaptor, first remove it. Do not put a normal CD (12 cm/5-inch) on top of a 8 cm CD.

## Notes on handling discs

- To keep the disc clean, handle the disc by its edge. Do not touch the surface.
- Do not stick paper or tape on the disc.



- Do not expose the disc to direct sunlight or heat sources such as hot air ducts, or leave it in a car parked in direct sunlight as there can be a considerable rise in the temperature.
- After playing, store the disc in its case.

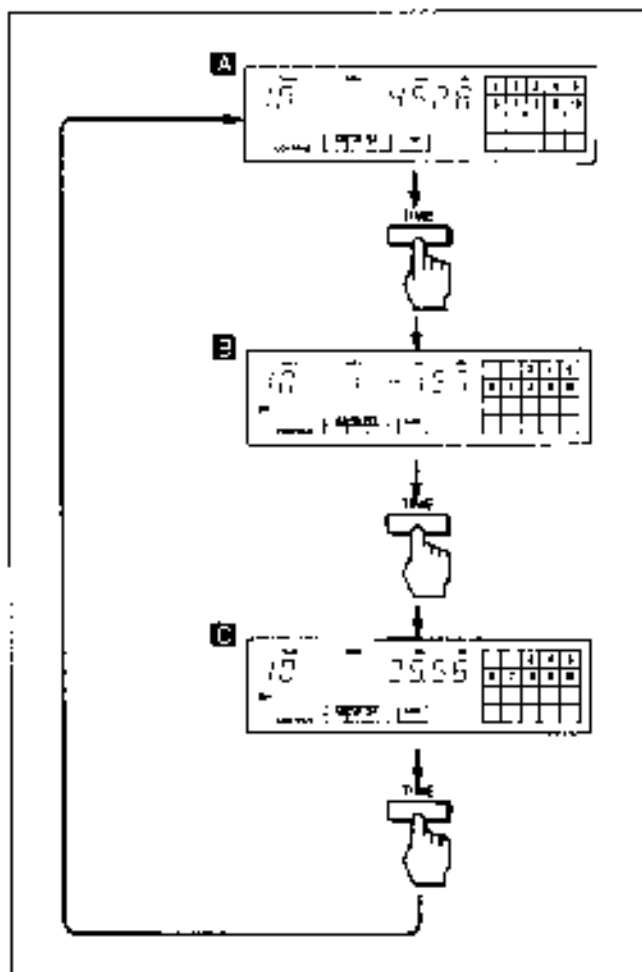

## Information Display

Each time you press TIME/MEMO (or TIME on the Remote Commander) during play, the display changes to give you the following information.

- A** Elapsed playing time
- B** Remaining time in a selection  
If the current selection number is over 20 "----" is displayed.
- C** Remaining time of the disc

### *If you have stored a disc memo*

The stored disc memo will be displayed following the display of the remaining time of the disc.

## Locating a Particular Selection

You can locate the beginning of a desired selection during play or pause.

### To locate sequentially

To locate the beginning of the current or preceding selection

Press **⏮** as many times as required.

Keep **⏮** pressed to skip selections.

To locate the beginning of a succeeding selection

Press **⏭** as many times as required.

Keep **⏭** pressed to skip selections.

### When you press **⏮** during play

The player locates the beginning of the selection.

### To locate directly

Press one of the numeric buttons (**[T]** to **[20]**) to enter the desired selection number.

If a selection number is greater than 20, use the **[>20]** and **[1]** to **[10]** buttons. **[10]** functions as the figure 0.

e.g. To play from selection No. 22 Press **[>20]** **[2]** **[2]**  
To play from selection No. 30 Press **[>20]** **[3]** **[10]**

## Locating a Particular Point in a Selection

You can locate a particular point in the disc during play.

### To search quickly while monitoring the sound

To go ahead at high speed

Keep **⏭** pressed during play and release at the desired point

To go back at high speed

Keep **⏮** pressed during play and release at the desired point.

### To search quickly by observing the display

Press **⏮** then keep **⏭** or **⏮** pressed. The search speed will increase, but there will be no sound. Find the desired point by observing the display.

Press **[1]** again at the desired point.



### To search slowly while monitoring the sound

Press **⏮** **⏭** SLOW during play and release at the desired point.

## Locating an Index



This function is only possible with a disc on which index numbers are recorded.

### What is an index?

This is a number assigned to a section of a selection (for example, to a movement in a symphony) to allow that section to be located easily.

Press **⏮** or **⏭** to locate the desired index number. The selected index number appears in the display window.

### "OVER" is displayed..

If you continuously press **⏭** at the end of the disc,

"OVER" appears in the window. Press **⏮** or **⏭** to return to normal indication.

If you continuously press **⏮** at the beginning of the disc, play begins automatically from the first selection.



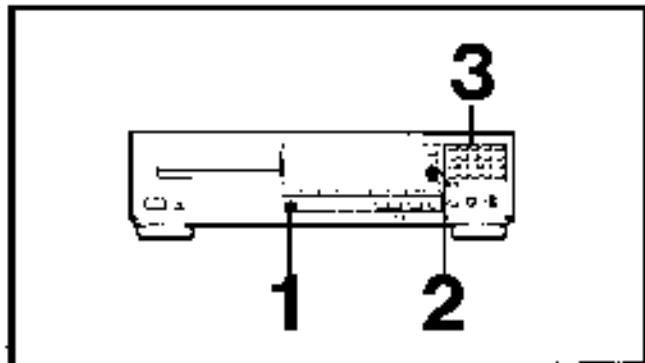

**1**



**2**

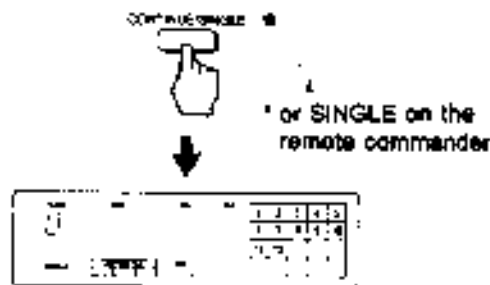

**3**

Choose selection.



or



Play stops when the chosen selection ends.

## Playing a Single Selection – Single Play

You can play just one selection and then stop instead of playing the entire disc.

To cancel single play  
Press CONTINUE/SINGLE again  
"CONTINUE" appears.

# Playing in a Random Order -Shuffle Play

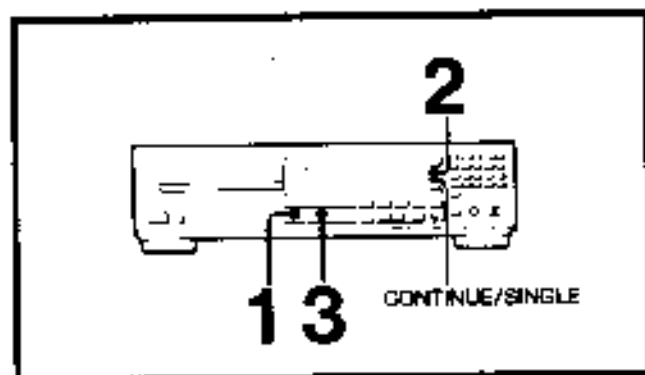

1



2



3



You can have the selections played in a random order. The unit will play all the selections, or just the selections you desire.

#### To stop playing

Press ■

#### To cancel shuffle play

Press CONTINUE/SINGLE (or CONTINUE on the remote commander) and return to the normal playing mode.

#### To check the remaining time of the current selection

Press TIME/MEMO (TIME on the remote commander) once.

Press TIME/MEMO again to return to the normal display.

#### If you press SHUFFLE during play

Shuffle play begins from the current selection.



#### What is this indication?

This indication appears while the player is "shuffling" the selections.

## To play only the desired selections in a random order -Delete Shuffle Play

Delete the undesired selections before or during play.

To delete a selection, press the numeric button for that selection. "OFF" will be displayed in the window. You cannot delete a selection which is being played. To choose a selection number over 20, see page 8.

To put back a selection which you have deleted, press the numeric button for that selection. "ON" will be displayed in the window.

#### When delete shuffle play ends

The unit returns to the shuffle play mode for all selections.

#### To check the remaining time of the selection being played

Press TIME once; press once more to return to the initial display. The total remaining time will not be displayed.

# Playing Repeatedly -Repeat Play

## Repeating Selections

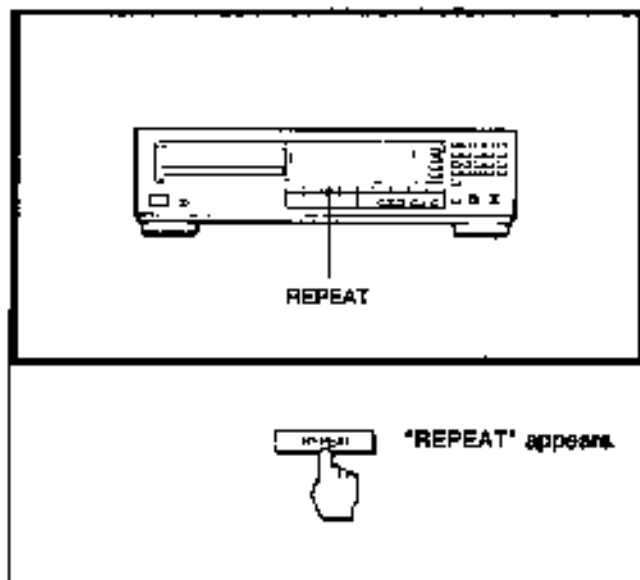

Before or during play.

The unit repeats on the current playing mode.

Playing mode	Selections to be repeated
Continuous play	All the selections
Single play	Current selection
Program play	All the selections programmed in the same order
Shuffle play	Selections that the player reshuffles
Custom Index play	Between the specific custom indexes

To cancel repeat play  
Press REPEAT again.  
\*REPEAT\* disappears.

## Repeating a Particular Portion - A ◀ ▶ B Repeat

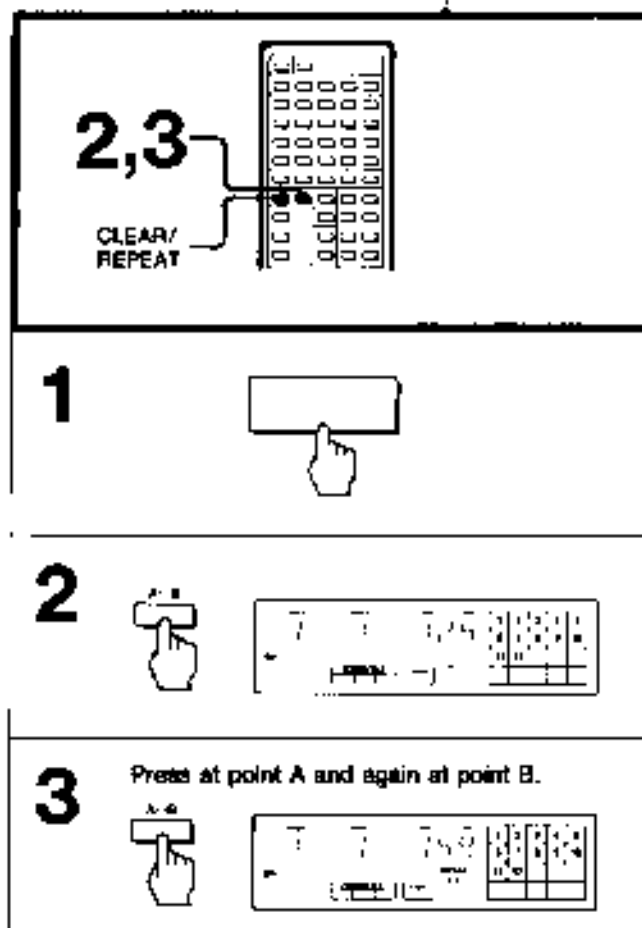

You can repeat a portion on the disc by designating the starting point (A) and the ending point (B).

### To cancel A ◀ ▶ B repeat

Press CLEAR/REPEAT (or REPEAT on the player).

Going back to point A from any point on the disc  
Simply press ▶. When point A is stored, you can go back there in any play mode. You need not designate point B.

### If you designate repeat play during delete shuffle play

When the selections you chose end, repeat play of all the selections will start.

### When you designate A ◀ ▶ B repeat during shuffle or program play

You cannot designate point A and B in two different selections.

# Playing in a Desired Order -Program Play

You can make a program by designating up to 20 selections in the order you want them to be played. The unit will play the disc according to your program.

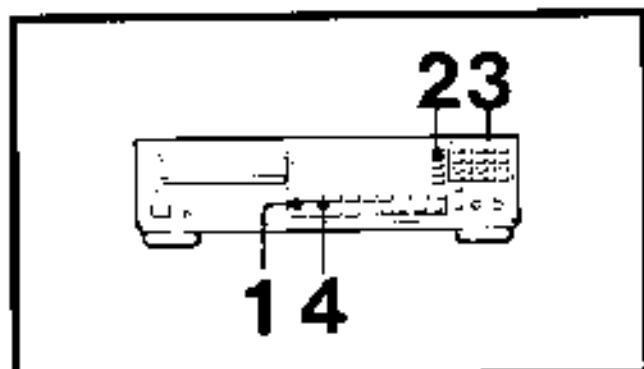

1



2



3

Press selection number in the desired order.\*

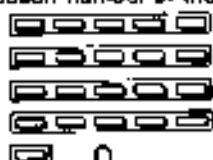

4



## To stop playing

Press ■ .

You can play the same program repeatedly as long as you do not cancel program play or erase the program.

## To cancel program play

Press CONTINUE/SINGLE (or CONTINUE on the remote commander) and return to the normal playing mode. The program will be erased.

## To erase the entire program

Press ■ once during stop; twice during play. The program is also erased when you turn off the unit.

## To make a program for editing a tape

You can insert a pause in your program. Use this function to make a program for both sides of the tape at one time.

- 1 Program the selections for side A.
- 2 Press II "P" will be displayed and the total playing time will be reset to 0.
- 3 Program the selections for side B.

When you start playing, the selections for side A will be played and then the unit will pause. Set the tape to the beginning of side B, then press II. The selections for side B will be played.

\* To choose a selection number over 20, see page B.

#### **To check your program**

Press CHECK. The first selection in the program will be displayed.

Each time you press CHECK, the next selection in the program will be displayed. The last selection will be indicated with the display "END".

To return to the initial display, press CHECK once more.

#### **To change your program**

You can make the following changes before starting play.

##### **To erase the last selection, press CLEAR.**

Each time you press CLEAR, the last selection in the program will be erased.

To add a selection to the end of the program, just press the numeric button for that selection. You can add a selection also during play or pause.

To delete a selection, press CHECK repeatedly until the undesired selection is displayed. Then press

CLEAR. .

To change the order, press  during stop to erase the program. Then repeat the programming procedure from the beginning.

##### **To adjust the blank spaces between selections**

In a program, if you do not change the order of selections, the spaces between those selections remain the same as on the disc. Otherwise, the spaces are shortened to 1 second. You can make all the blank spaces 3 seconds long. See page 13 for details.

##### **If "----" is displayed instead of the actual time**

- you have programmed a selection number over 20.  
the total time has exceeded 100 minutes.

##### **To check the remaining time**

Press TIME/MEMO once to see the remaining time of the selection being played; twice to see the total remaining time; once more to return to the initial display.

If you have inserted a pause, the display shows the remaining number of selections and time until the pause.

If you have programmed a selection number over 20, "----" is displayed instead of the actual time.

# Designating the Playing Order -Program Edit

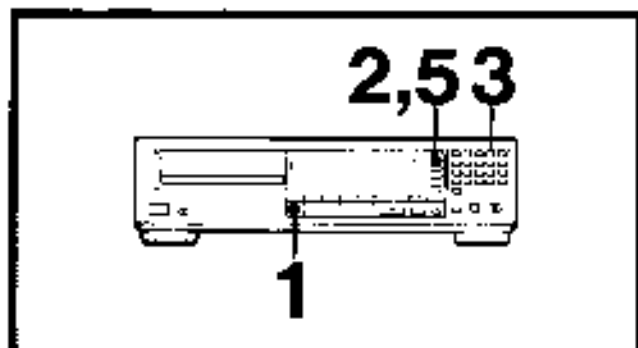

1



2



3

Choose selection and check the time.

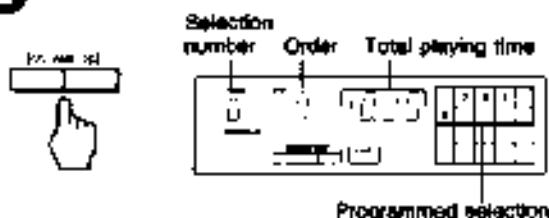

4

If satisfactory, go to next step.  
If not, repeat step 3 and choose another selection.

5

Store selection.



6

Repeat steps 3 to 5.

You can make a program by designating up to 20 selections in the order you want them to be played. At the same time, you can adjust the total playing time of the program. The unit will play the disc according to your program. This function is convenient for editing tapes.

#### To play the program

Press **▶**.

#### To stop playing

Press **■**.

You can play the same program repeatedly as long as you do not cancel program edit or erase the program.

#### To cancel program edit

Press CONTINUE/SINGLE (or CONTINUE on the remote commander) and return to the normal playing mode. The program will be erased.

#### To erase the entire program

Press **■** once during stop, twice during play. The program is also erased, when you turn off the unit.

#### To make a program for editing a tape

You can insert a pause in your program. Use this function to make a program for both sides of the tape at one time. See page 16 for details.

#### To check or change your program

See page 13.

#### To adjust the blank spaces between selections

In a program, if you do not change the order of selections, the spaces between those selections remain the same as on the disc. Otherwise, the spaces are shortened to 1 second. You can make all the blank spaces 3 seconds long. See page 16 for details.

# Designating the Total Playing Time - Time Edit

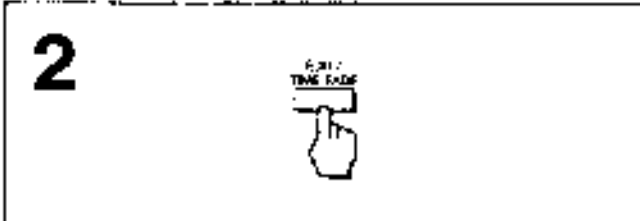
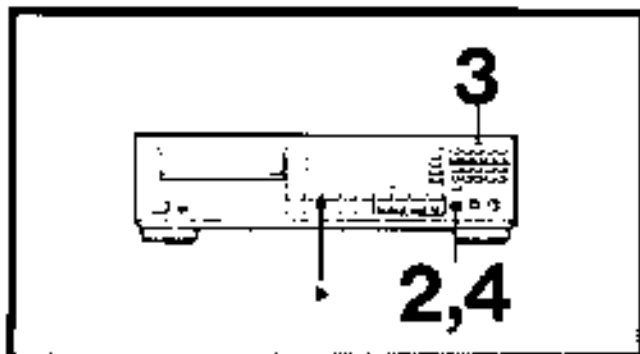

**3** Designate the length of one side of your tape.  
Example: a 48 minute tape  
(23 minutes per side)

**4**

**5** Press EDIT/TIME FADE once more to make a program for side B.

You can designate a time and the unit will make 2 different programs of selections each fitting within that period. Use this function, by designating the length of your tape, for editing both sides of a tape.

\* Press  $\overline{10}$  for "0".  
You need not press keys for seconds, unless required

**To play the program**  
Press  $\blacktriangleright$ .  
The selections for side A will be played and then the unit will pause. Set the tape to the beginning of side B, then press  $\blacktriangleleft$ . The selections for side B will be played.

**To stop playing**  
Press  $\blacksquare$ .  
You can play the same program repeatedly as long as you do not cancel time edit or erase the program.

**To cancel time edit**  
Press CONTINUE/SINGLE (or CONTINUE on the remote commander) and return to the normal playing mode.  
The program will be erased.

**To erase the entire program**  
Press  $\blacksquare$  once during stop; twice during play.  
The program is also erased, when you turn off the unit.

**To include desired selections in the program**

- 1 Make your own program of the desired selections. See page 13 for instructions.
- 2 Follow the procedure on the preceding page. Just designate the length of your tape. you need not subtract the length of your program. The unit will place your selections at the beginning of its program and add other selections to fit the remaining time.

**To check the program**  
See page 13.

**If your disc has more than 20 selections**  
You cannot use the time edit function; use the program edit function instead.

**If any selections remain unprogrammed**  
To make a further program, repeat step 5.

**To designate a different time for each side**  
Execute steps 1 to 4, then repeat steps 3 and 4. Do not execute step 5.

# Tips on Editing Tapes

The following functions are convenient for editing your own tapes.

## Fading Out at the Desired Time - Time Fade

You can have the play fade out at the end by designating the play duration.

You can use this function in any play mode.

- 1 Press EDIT/TIME FADE twice during stop. "TIME FADE" is displayed in the window.
- 2 Set the desired play duration, using numeric buttons. e.g. To set to 27 minutes, press **2** **7** **10** **.10**. You need not press buttons for seconds, unless required.
- 3 To start play, press **▶**.  
Play starts to fade out five seconds before the time set, and the unit enters the pause mode.

If you want to start the play fading in

- 1 Press **||**.  
The unit enters the pause mode.
- 2 Press EDIT/TIME FADE once.  
"TIME FADE" is displayed.
- 3 Set the desired play duration, following the step 2 above.
- 4 To start play, press FADER. **▶**  
Play will start fading in and end at the set time fading out.

To resume play after fading out

Press **||** or FADER. (Pressing FADER starts the play fading in.)

To cancel time fade

Press **■** or **▲**.

Time fade is also cancelled when

- **◀** / **▶** or **⏮** / **⏭** is pressed during play.
- Other play mode buttons are pressed.

To display the time remaining until the time set

Press TIME twice. In the shuffle play mode, however, the time remaining until the fade-out time is not displayed.

## Fading in/Fading out

You can have the play fade in and fade out for five seconds.

To end the play fading out

Press FADER when you want to start fading out.

"FADE **▶**" flashes in the window, and play fades out for 5 seconds and enters the pause mode.

To restart the play fading in

Press FADER.

"FADE **▶**" flashes in the window, and play fades in for 5 seconds.

## Inserting a Blank Space between Selections -Auto Space



You can insert a 3 second blank space between each selection. The blank space enables you to locate selections when using a tape deck with the automatic selection search function.

Before starting play, press AUTO SPACE so that "AUTO SPACE" is displayed in the window.

A blank space of approximately 3 seconds will be inserted between each selection.

To cancel the auto space function

Press AUTO SPACE so that "AUTO SPACE" disappears from the window.



# On Custom Files

The CD player incorporates a memory in which you can store three types of informations called "custom files"

## Three custom files you can store in memory

Disc memo	You can assign a title within 12 letters to each individual disc. (page 18)
Program bank	A programmed playing order you store in memory for a disc, so that the disc can be played always in a fixed order. (page 18)
Custom index	You can assign up to 10 index points on anywhere you want on a disc. (page 20)

What is this indication?

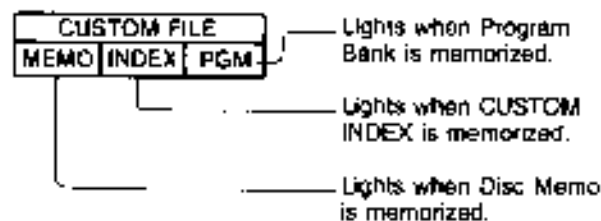

## How many discs can be assigned custom files?

You can give custom files to up to 227 discs.

## Memory backup for the custom files

Custom files, once memorized, are retained in the compact disc player's memory for approximately 1 month without AC power supply.

## It takes two disc's memory,

- when Disc Memo, Custom Index and Program Bank are memorized in one disc at the same time.
- when more than 8 Custom indexes and Disc Memo are memorized at the same time.
- when Custom Index and Program bank are memorized at the same time.

## What is this indication?

FILE CLR

This indication appears when FILE is pressed while no custom file can be memorized for the disc currently put in the player. To make a custom file for the disc, clear the custom file of another disc.

## To clear all custom files of a disc at once

Put the disc in the player and press ERASE. The disc memo and program bank (or the disc memo and custom indexes) are all cleared and "FILE CLR" appears.

## To clear custom files of all discs at once

Press POWER to turn on the player while keeping ERASE and FILE pressed.

## To check the items of the custom files

Press FILE RECALL ("DISC/MEMO" is displayed) without the disc inserted. Each time you press FILE RECALL, the items of the custom files and items of the each column of **DISC/MEMO** about the disc are displayed. If you press FILE RECALL when the last disc's information is displayed, END is displayed and returns to "DISC MEMO" after a few seconds.

# Keeping the Program in Memory -Program Bank Function

## Memorizing a Program

After programming selections, you can keep the program memorized, so that the disc is played always in the fixed order. The memorized program is called "program bank". One program bank can be made for a disc.

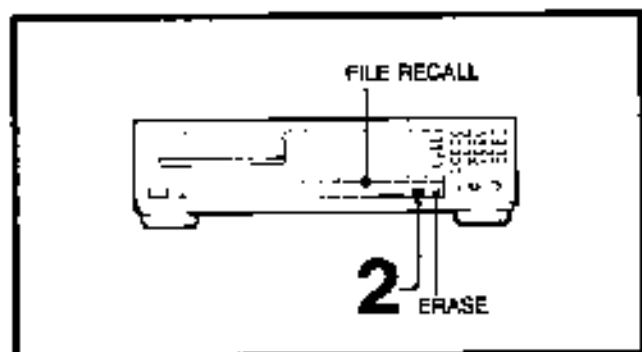

**1** Program the selections as you want (page 13)

**2** Press FILE.

When "PGM" lights, the program is memorized for the program bank.

### To change the program bank

Program the selections again and press FILE.

### Where is the program bank memorized?

The program bank is memorized in the compact disc player's memory. Therefore, if a disc for which you made a program bank is used with another compact disc player, play using the program bank is not possible.

## Playing the Disc Using the Program Bank

- 1 Press PROGRAM.  
"PROGRAM" appears.
- 2 Press  $\Delta$  and put the disc in the disc compartment.
- 3 Press  $\blacktriangleright$ .

### When the disc is in the disc compartment

- 1 Press FILE RECALL during stop.  
"PROGRAM" appears.
- 2 Press  $\blacktriangleright$ .

### To play a disc having a program bank in other modes

Put the disc in the disc compartment, program the selections as you want and press  $\blacktriangleright$ . The disc will be played in the newly programmed order.

The memorized program bank won't be cleared. (Press FILE RECALL to check the program bank.)

### To play the selections in another program without clearing the program bank

To play a disc having a program bank in other modes, put the disc in the disc compartment, set the player in the desired play mode and press  $\blacktriangleright$ .

### What is this indication?

 This indication appears when you put the disc whose program bank has already been memorized.

## Clearing the Program Bank

- 1 Put the disc whose program bank is to be cleared in the player.
- 2 Press FILE RECALL.
- 3 Press ERASE.  
When "FILE CLR" is displayed and "PGM" disappears, the program bank is cleared.

# Assigning names to a Disc -Disc Memo Function

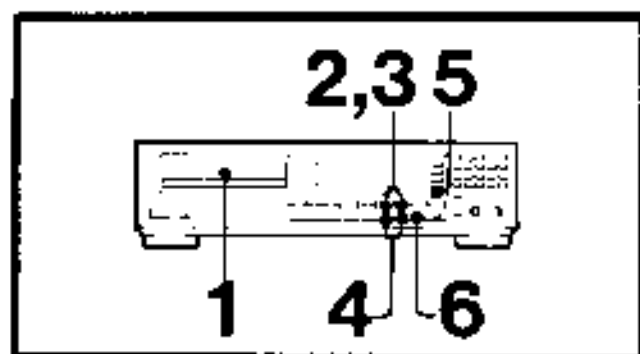

1



Make sure that the total number of selections and the total playing time is displayed. Then proceed as follows in the stop mode.

2

A blinking cursor (indicating where a letter will be written) appears.



blinks

3

Press ◀ or ▶ until the desired letter appears.  
Example: If ▶ is pressed 6 times, F appears.

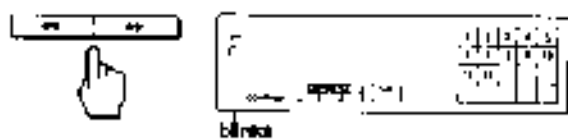

blinks

4

To move the cursor to select the desired letter.

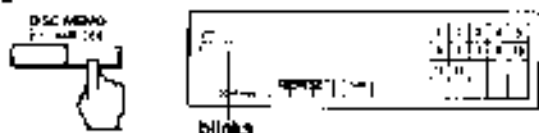

blinks

Repeat steps 3 and 4 to complete the memo.

5

"FILE" appears in the window. After about 1 second, the memo you have written will be displayed.



Each time the disc is put in the compact disc player, the memo will be displayed.

Using the disc memo function, you can assign a name within 10 letters for each disc. The memo appears in the window every time you put the disc in the player. One name can be assigned for one disc.

## To rewrite letters or symbols

Before pressing FILE, move the cursor under the letter/symbol to be changed and then select the desired letter/symbol using ◀ ▶.

To erase the letter and make space, locate the desired place with ◀ ▶ and press CLEAR.

## After pressing FILE

Repeat the steps from 2.

## Usable letters and symbols

For the disc memo, 47 letters and symbols and space can be used. When the ◀ ▶ button is pressed for the first time, the space appears. Each time ▶ is pressed, letters and symbols will appear in the following order.

(space)	A	B	C	D	E	F	G	H	I	J	K	L	M	N	O	P	Q	R	S	T	U	V
W	X	Y	Z	F	d	*		+	/	\	>	<	9	8	7	6	5	4	3	2	1	0

Use ◀ to call up a previous character

## What is the indication?

This indication appears when you put the disc whose disc memo has already been memorized.

## If you press TIME/MEMO during stop

Each time you press TIME/MEMO, the memo that has already been memorized appears and disappears.

## To display the playing time of the disc whose memo has already been memorized

When the total remaining time of the disc is displayed, if you press TIME/MEMO, memo will be displayed. (During shuffle play, press TIME/MEMO twice and the memo will be displayed.)

## Where is the disc memo stored?

The disc memo is stored in the compact disc player's memory. When a disc is put in the player, the player identifies the disc by the total number of selections and the total playing time. If a disc memo has been made for that disc, the player retrieves the memo from its memory and displays it in the window. Therefore, as the disc memo is not located on the disc itself, when the disc is put in another compact disc player, no memo will be displayed.

## Clearing the Disc Memo

- 1 Put the disc whose memo you want to clear in the player.
- 2 Press ◀ or ▶ on the player.
- 3 Press ERASE.  
"FILE CLR" is displayed in the window.

# Giving a Disc Indexes as You Want -Custom Index Function

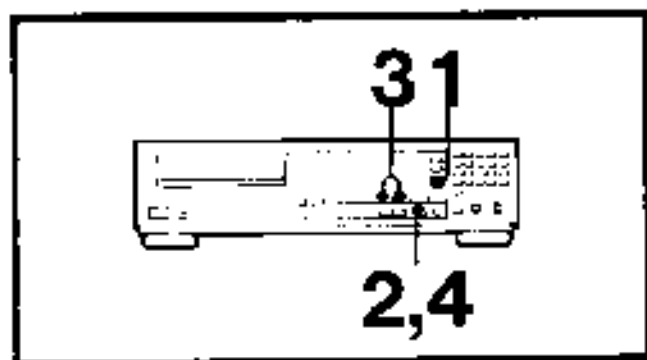

A custom index is a special index that can be assigned to any position you want on the disc. If you assign custom indexes to the positions on a disc, you can easily locate the positions during play, or enjoy repeat play between two adjacent custom indexes.

- 1 Press CUSTOM INDEX during play.
- 2 Press FILE where you want to assign a custom index. The portion for 3 seconds from the point where you pressed FILE is played repeatedly (rehearsal play).
- 3 Adjust the repeat start point using ◀ or ▶. Press ▶ to shift the repeat start point forward and ◀ to shift it backward. Pressing ◀ ▶ 7 times shift the point by approximately 1 second.
- 4 Press FILE.  
The custom index is assigned to the repeat start point.
- 5 You can assign custom indexes up to 10 positions by repeating steps from 2 to 4.

**To release rehearsal play**  
Press CLEAR. Normal play is resumed.

#### What is this indication?

 This indication appears when you put the disc whose custom index has already been memorized.

#### If a new custom index is assigned to a position preceding another index

Previously existing indexes will be shifted as follows.  
Example. If you assign a new index between 2 and 3.

1 2 3            1 2 3 4

A new index      The old index 3 becomes 4

#### If you press FILE in the pause mode

The rehearsal play is not made and the custom index is assigned immediately at the position where FILE is pressed.

#### Where are the custom indexes memorized?

The custom indexes are memorized in the compact disc player's memory. Therefore, if a disc for which custom indexes are assigned is played in other compact disc player, play using the custom indexes cannot be done.

#### During custom index play

You cannot use the normal custom search function.

## Playing from the Desired Custom Index

- 1 Press CUSTOM INDEX MODE.
- 2 Press the desired numeric button 1 through 10.

#### To change the play mode during play using custom indexes

During play using custom indexes (in other words, when the music calendar is not displayed), the play mode switches from continuous play to single play and vice versa each time CUSTOM INDEX MODE is pressed.

#### To release play using custom indexes

Press one of the PLAY MODE buttons (PROGRAM, SHUFFLE or CONTINUE/SINGLE). The music calendar appears.

## Clearing Custom Indexes

- 1 Press CUSTOM INDEX and C.INDEX appears.
- 2 Press CHECK.  
Each time you press CHECK, index number blinks. Select the index number you want to delete.
- 3 Press ERASE while index number blinks.

## Repeating the Portion between Two Custom Indexes

During play using custom indexes, you can repeat the desired portion between any two adjacent custom indexes.

- 1 Press CUSTOM INDEX MODE twice so that "C.INDEX SINGLE" is displayed in the window.
- 2 Press one of the numeric buttons 1 to 10 for the starting point of the repeat play.
- 3 Press REPEAT.

The portion between the custom index designated as the starting point and the next custom index is played repeatedly.

**To cancel repeat play between custom indexes**  
Press REPEAT.

# Timer Activated Playing

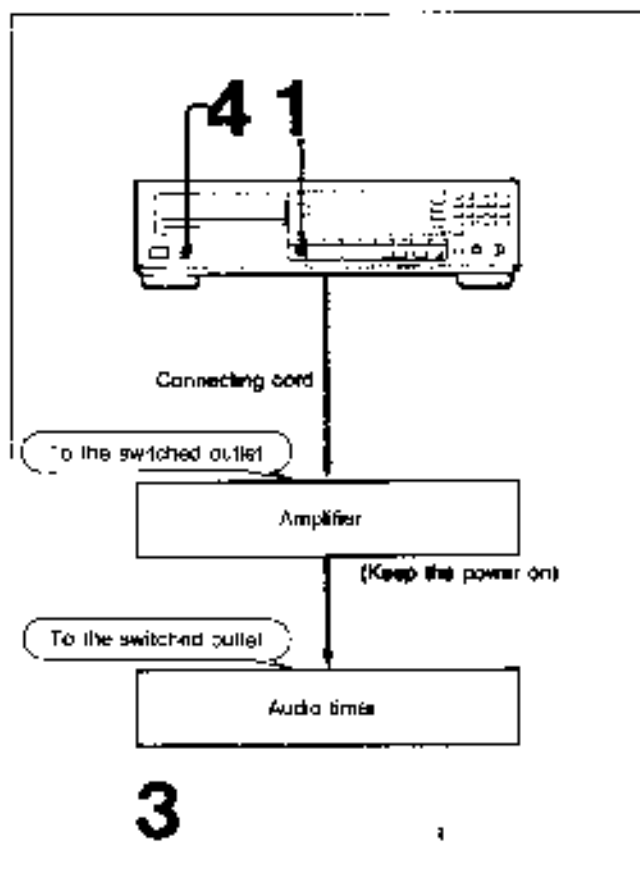

By connecting a commercially available timer, disc play of the desired play mode can be started at any desired time.

- 1** Insert a disc in the compartment.
- 2** Select the desired play mode.
- 3** Set the timer.
- 4** Set **TIMER** to **PLAY**.

Keep the **POWER** switch depressed on the player. When the timer is set, the power of the player will be cut off. However, be sure to leave the **POWER** switch on.

When the timer-activated play ends. Be sure to set **TIMER** to **OFF**. If the **TIME** switch is left at **PLAY**, the unit will automatically start playing the next time the power is turned on.

To play in the program play mode. Make a program bank (page 19), and then prepare for timer activated playing.

If you select the custom index play mode. Play begins from custom index 1.

# Maintenance

## Cleaning Your Unit

Clean the cabinet, pane and controls with a soft cloth lightly moistened with a mild detergent solution. Do not use any type of abrasive pad, scouring powder or solvent such as alcohol or benzine.

## Cleaning Discs

When a disc becomes dirty, clean it with a cleaning cloth. Wipe the disc from the center out.



Do not use solvents such as benzine, thinner, commercially available cleaners or anti-static spray intended for analog discs.

# Installing the CD Player

## Notes on Installation

- Place the unit in a location with adequate air circulation to prevent internal heat build up in the unit.
- Do not place the unit on a soft surface, such as a rug that would block the ventilation holes on the bottom.
- Do not install the unit,
  - near heat sources such as radiators or air ducts.
  - in a place subject to direct sunlight, excessive dust, mechanical vibration or shock.

Not this way.



### On moisture condensation

If the player is brought directly from a cold to a warm location, or is placed in a very damp room, moisture may condense on the lens inside the unit. Should this occur, the player will not operate. In this case, remove the disc and leave the player turned on for about an hour until the moisture evaporates.

# Precautions

### On safety

- Operate the unit only on 120 V AC, 60 Hz.
- Should any liquid or solid object fall into the cabinet, unplug the unit and have it checked by qualified personnel before operating it any further.
- Unplug the unit from the wall outlet if it will not be used for a long time. To disconnect the cord, pull it out by grasping the plug. Never pull the cord itself.
- As the laser beam used in this compact disc player is harmful to the eyes, do not attempt to disassemble the cabinet. Refer servicing to qualified personnel only.

### On operation

When the unit is not used, turn the power off, to conserve energy and to extend the useful life of your unit.

### Important

Since the CD system boasts a wide dynamic range, the peaks of high level inputs are recorded with high fidelity, and the noise level is very low. Do not turn up the volume while listening to a portion with no audio signals or very low level inputs if you do. The speakers may be damaged when a peak level portion is played.

For detailed safety precautions, see the leaflet "IMPORTANT SAFEGUARDS".

If you have any questions or problems concerning your unit, please contact your nearest Sony dealer.

# Specifications

## Compact disc player

Frequency response	2 Hz -20 kHz $\pm$ 0.3 dB
Signal to noise ratio	More than 110 dB
Dynamic range	More than 97 dB
Harmonic distortion	Less than 0.003 %
Channel separation	More than 100 dB

## Outputs

LINE OUT <sup>+</sup> (FIXED) (phono jacks)	Output level 2 V (at 50 kilohms) Load impedance over 10 kilohms
LINE OUT <sup>-</sup> (VARIABLE) (phono jacks)	Output level max. 2 V (at 50 kilohms) Load impedance over 10 kilohms
DIGITAL OUT (OPTICAL; optical output connector)	Wave length 660 nm Output level 18 dBm
HEADPHONES (stereo phone jack)	Output level max. 28 mW Load impedance 32 ohms

## General

Power requirements	AC120 V 50/60 Hz
Power consumption	13 W

	CDP-970	CDP-508ESD
Dimensions	Approx. 430 × 110 × 340 mm (w/h/d) (17 × 4 3/8 × 13 3/5 inches) Including projecting parts and controls	Approx. 470 × 115 × 340 mm (w/h/d) (18 1/2 × 4 1/2 × 13 3/5 inches) Including projecting parts and controls
Weight	Approx. 5 kg (11 lbs 1 oz), net	Approx. 6.6 kg (14 lbs 9 oz), net

## Remote commander RM-D570

Remote control system	Infrared control
Power requirements	3 V DC with two batteries size AA (IEC designation R6)
Dimensions	67 × 20 × 175 mm (w/h/d) (2 3/4 × 13/16 × 7 inches)
Weight	135 g (4.7 oz) including batteries

## Supplied accessories

Connecting cord (1) (2 phono plugs - 2 phono plugs)
Remote commander (1)
Size AA batteries (2)

## Optional accessory

Audio Optics connecting cord POC 15
-------------------------------------

Design and specifications subject to change without notice

# Troubleshooting Guide

Before going through the check list below, first refer back to the connections and operating procedures.

Should any problem persist after you have made these checks, consult your nearest Sony service facility.

Symptom	Cause	Remedy
The disc tray does not close.	The disc is not placed correctly.	Place the disc correctly on the disc tray.
Play does not start.	Dirty disc.	Clean the disc.
	The disc is inserted upside down.	Insert the disc with the printed side up.
	The player is in the pause mode.	Press II (or II on the remote commander) to release pause.
"DISC/MEMO" is displayed.	Moisture condensation.	Leave the player turned on for approximately one hour.
	There is no disc in the unit.	Insert a disc.
Sound is not heard.	Loose connection.	Insert the plug firmly.
	Connection is incorrect.	Check the connection referring "Connecting the CD Player".
	The LINE OUT/PHONE LEVEL control is set to the minimum.	Turn the control clockwise.
Play does not begin from the first selection.	The player is in the PROGRAM or SHUFFLE mode.	Press CONTINUE.
"DVFR" is displayed.	⏮ was continuously pressed at the end of the disc.	Press ⏮ or ⏪ to return to normal indication.
The remote commander does not operate the unit.	The batteries are run down.	Replace both batteries.
	The remote commander is not pointed at the remote sensor.	Point the remote commander at the sensor.
	There is an obstacle between the remote commander and the unit.	Remove the obstacle.
	The remote commander is too far from the unit.	Move closer.
Any operation is not possible.	The internal control program may not run.	Turn off the power and turn it on again.