

CDP-227ESD/507ESD

SERVICE MANUAL

AEP Model
UK Model
 CDP-227ESD
US Model
Canadian Model
E Model
 CDP-507ESD



photo: CDP-507ESD

SPECIFICATIONS

Compact disc player

System	Compact disc digital audio system
Laser	Semiconductor laser ($\lambda = 780 \text{ nm}$)
Emission duration	Continuous
Laser output	Max. $44.6 \mu\text{W}$ <small>* This output is the value measured at a distance of 200 mm from the objective lens surface on the Optical Pick-up Block.</small>
Frequency response	2 Hz - 20 kHz $\pm 0.5\text{dB}$
Signal to noise ratio	More than 106 dB
Dynamic range	More than 96 dB
Harmonic distortion	Less than 0.0025%
Wow and flutter	Below measurable limit
Channel separation	More than 100dB

Outputs

LINE OUT (FIXED) (phono jacks)	Output level 2 V (at 50 kilohms) Load impedance over 10 kilohms
LINE OUT (VARIABLE) (phono jacks)	Output level max. 2 V (at 50 kilohms) Load impedance over 50 kilohms
DIGITAL OUT (COAXIAL) (phono jacks)	Output level 0.5 V _{p-p} (at 75 ohms) Load impedance 75 ohms
DIGITAL OUT (OPTICAL) (optical output connector)	Wave length 660 nm Output level -18 dBm
HEADPHONES (stereo phone jack)	Output level max. 28 mW Load impedance 32 ohms

General

Power requirements	AEP model (CDP-227ESD) 220 V AC (or 240 V AC adjustable by Sony personnel), 50/60 Hz UK model (CDP-227ESD) 240 V AC (or 220 V AC adjustable by Sony personnel), 50/60 Hz US, Canadian model (CDP-507ESD) 120 V AC, 60 Hz E model (CDP-507ESD) 110, 120, 220 or 240 V AC adjustable, 50/60 Hz
Power consumption	22 W
Dimensions (approx.)	430 x 110 x 345 mm (w/h/d) (17 x 4 $\frac{1}{8}$ x 13 $\frac{5}{8}$ inches) including projecting parts and controls
Weight (approx.)	6.3 kg (13lbs 15oz)

Supplied accessories

Audio signal connecting cord	1 (2 phono plugs—2 phono plugs)
Remote commander	1
Sony SUM-3 (NS) batteries	2
Screw driver	1

— Continued on page 2 —



COMPACT DISC PLAYER
SONY®

Remote commander

Remote control system	Infrared control
Power requirements	3V DC with two R6 (size AA) batteries
Dimensions	Approx. 62 × 20 × 168.5 mm (w/h/d) (2½ × 1¾ × 6¾ inches)
Weight	Approx. 130 g (5 oz) including batteries

Optional accessory

Optical cable POC-15

Note

This appliance conforms with EEC Directives 76/889 and 82/499 regarding interference suppression.

Features

Custom file function

- **Disc memo function** for writing a comment about a disc.
- **Program bank function** for storing a programmed playing order.
- **Custom index function** for assigning your own index point to any desired position on a disc.

Program play

You can play up to 20 selections in the desired order. Pause can be also programmed. You can also confirm the total playing time while choosing the selection to be programmed.

Variety of playing modes

Single play, program play, shuffle play and repeat play as well as normal continuous play of a whole disc.

Large and easy-to-read window display

Shows the elapsed playing time, the remaining time of the selection being played, the remaining time of the whole disc or the remaining programmed selection numbers. The display contains a music calendar indicating all the numbers of the selections on the disc.



Operating Voltage

Before connecting the unit to the power source, check that the operating voltage of your unit is the same as the local power line voltage.

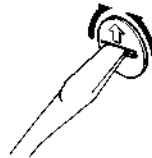
Model	Where purchased	Operating voltage
C	AEP model	Operates on 220V AC (or 240V AC adjustable by authorized Sony personnel), 50/60Hz
	UK model	Operates on 240V AC (or 220V AC adjustable by authorized Sony personnel), 50/60 Hz
	Canada model	Operates on 120V AC, 60Hz
E	E model	Operates on either 110, 120, 220 or 240V AC, 50/60Hz. The voltage selector is located on the rear panel. If the selector must be reset, disconnect the AC power cord and turn the selector with a coin or a similar object so that the arrow mark of the selector points to the proper voltage figure.



SAFETY-RELATED COMPONENT WARNING!!

COMPONENTS IDENTIFIED BY MARK  OR DOTTED LINE WITH MARK  ON THE SCHEMATIC DIAGRAMS AND IN THE PARTS LIST ARE CRITICAL TO SAFE OPERATION. REPLACE THESE COMPONENTS WITH SONY PARTS WHOSE PART NUMBERS APPEAR AS SHOWN IN THIS MANUAL OR IN SUPPLEMENTS PUBLISHED BY SONY.

ATTENTION AU COMPOSANT AYANT RAPPORT À LA SÉCURITÉ!

LES COMPOSANTS IDENTIFIÉS PAR UNE MARQUE  SUR LES DIAGRAMMES SCHÉMATIQUES ET LA LISTE DES PIÈCES SONT CRITIQUES POUR LA SÉCURITÉ DE FONCTIONNEMENT. NE REMPLACER CES COMPOSANTS QUE PAR DES PIÈCES SONY DONT LES NUMÉROS SONT DONNÉS DANS CE MANUEL OU DANS LES SUPPLÉMENTS PUBLIÉS PAR SONY.

TABLE OF CONTENTS

Section	Title	Page
Specifications		1
Features		2
Operating Voltage		2
Safety Check-out		3
Model Identification		3
SECTION 1. GENERAL		
Protection of Eyes from Laser Beam During Servicing		
Location and Function of Controls		5
Servicing Note		6
SECTION 2. ADJUSTMENTS		
SECTION 3. DIAGRAMS		
3-1. IC Block Diagrams		10
3-2. Block Diagram		11
3-3. Printed Wiring Boards (Display Section)		13
3-4. Semiconductor Lead Layouts		13
3-5. Schematic Diagram (Display Section)		15
3-6. Waveforms		19
3-7. Printed Wiring Boards (Main Section)		20
3-8. Schematic Diagram (Main Section 1/2)		23
3-9. Schematic Diagram (Main Section 2/2)		26
SECTION 4. EXPLODED VIEWS		
SECTION 5. ELECTRICAL PARTS LIST		

MODEL IDENTIFICATION

— Specification Label —

CDP-227ESD (AEP, UK model)
 CDP-507ESD (US, Canadian, E model)

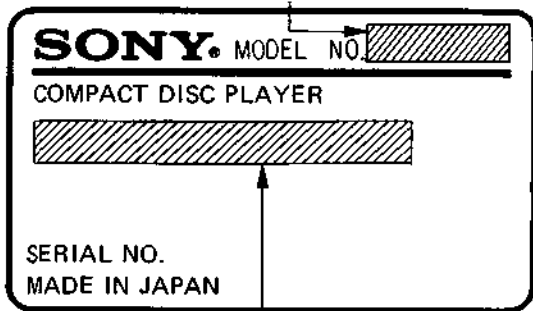

CDP-227ESD
 AEP, UK model: AC 220 – 240 V 50/60 Hz 20W

CDP-507ESD
 US, Canadian model: AC 120 V 60 Hz 20W
 E model: AC 110, 120, 220 – 240 V 50/60 Hz 20W

CDP-507ESD:

SAFETY CHECK-OUT

After correcting the original service problem, perform the following safety check before releasing the set to the customer:

Check the antenna terminals, metal trim, “metallized” knobs, screws, and all other exposed metal parts for AC leakage. Check leakage as described below.

LEAKAGE TEST

The AC leakage from any exposed metal part to earth ground and from all exposed metal parts to any exposed metal part having a return to chassis, must not exceed 0.5 mA (500 microampers). Leakage current can be measured by any one of three methods.

1. A commercial leakage tester, such as the Simpson 229 or RCA WT-540A. Follow the manufacturers’ instructions to use these instruments.
2. A battery-operated AC milliammeter. The Data Precision 245 digital multimeter is suitable for this job.
3. Measuring the voltage drop across a resistor by means of a VOM or battery-operated AC voltmeter. The “limit” indication is 0.75 V, so analog meters must have an accurate low-voltage scale. The Simpson 250 and Sanwa SH-63Trd are examples of a passive VOM that is suitable. Nearly all battery operated digital multimeters that have a 2 V AC range are suitable. (See Fig. A)

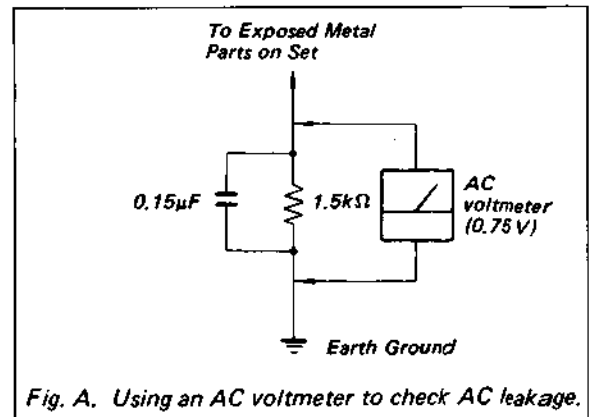

Fig. A. Using an AC voltmeter to check AC leakage.

PROTECTION OF EYES FROM LASER BEAM DURING SERVICING

This set employs a laser. Therefore, be sure to follow carefully the instructions below when servicing.

CAUTION

Use of controls or adjustments or performance of procedures other than those specified herein may result in hazardous radiation exposure.

1. Laser Diode Properties

- Material: GaAlAs
- Wavelength: 780 nm
- Emission Duration: continuous
- Laser Output: max. 44.6 μ W*

* This output is the value measured at a distance of about 200 mm from the objective lens surface on the Optical Pick-up Block.

2. During service, do not take the Optical Pick-up Block apart, and do not adjust the APC circuit. If there is a breakdown in the APC circuit (including laser diode), replace the entire Optical Pick-up Block (including APC board).

BESKYTTELSE AF ØJNE MOD LASERSTRÅLING UNDER SERVICE

I dette apparat anvendes laserlys. Derfor skal nedenstående instruktioner nøje følges under service.

Følg iverigt instruktionerne i servicemanualen.

ADVARSEL!!

Under service må øjnene ikke komme nær objektiv-linsen på den optiske pick-up enhed. I tilfælde af at det er nødvendigt at kontrollere udsendelsen af laserlys, skal det ske i en afstand af mere end 25 cm fra den optiske pick-up.

1. Laser-dioe data

- Materiale: GaAlAs
- Bølgelængde: 780 nm
- Udstråling: Kontinuerlig
- Laseroutput: Max. 0,4 mW*

* Målt i 1,6 mm afstand fra overfladen af objektiv-linsen på den optiske pick-up enhed.

- Klassifikation: Klasse IIIb.

2. Adskil aldrig den optiske pick-up enhed under service, og juster ikke APC kredsløbet (Automatic Power Control). Hvis APC kredsløbet (incl. laser-dioden) bryder ned, skal hele den optiske pick-up enhed (incl. APC printkortet) udskiftes.

LASER ADVARSEL MÆRKNING

Følgende mærkning findes indvendig i apparatet:

1. Advarsel Mærkning

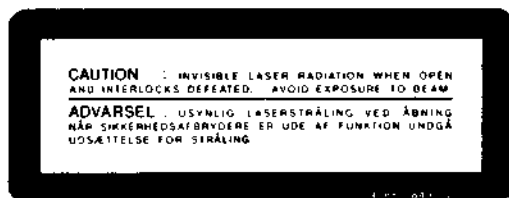

VAROITUS: Laite sisältää, laserdiodin, joka lähettää (näkyvätöntä) silmille vaarallista lasersäteilyä.

SECTION 1 GENERAL

LOCATION AND FUNCTION OF CONTROLS

Front Panel CDP-227ESD/CDP-507ESD

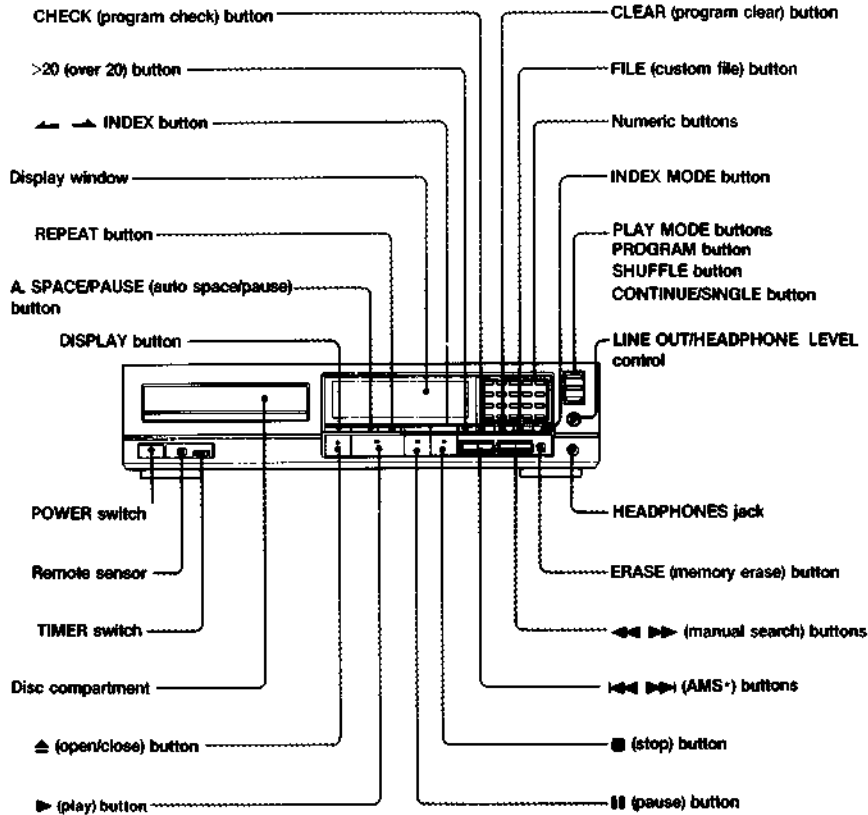

* AMS is an abbreviation of Automatic Music Sensor.

Remote Commander

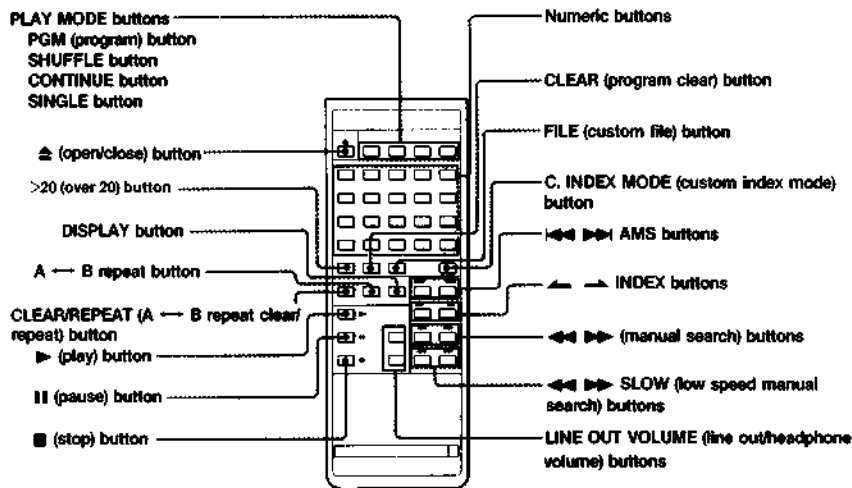

—SERVICING NOTE—

MANUAL OPENING OF DISCTABLE

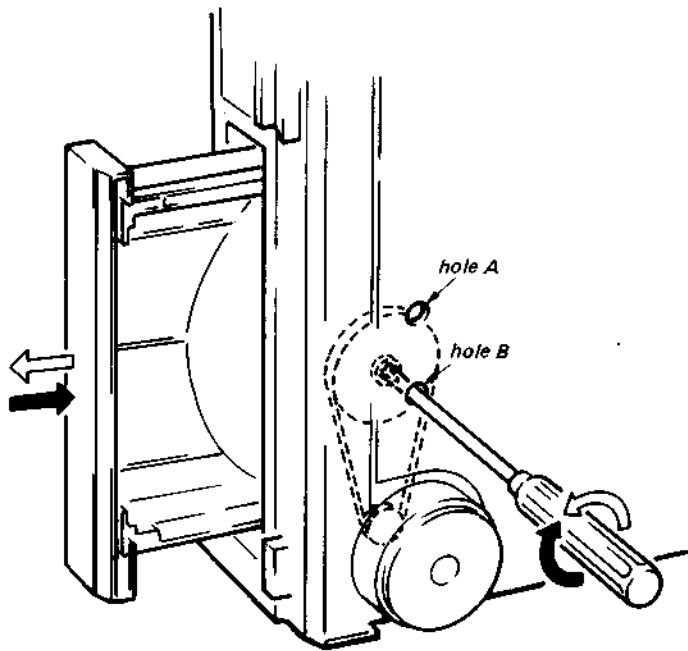

- How to open the disctable manually.
Insert a screwdriver(+) into the B hole on the bottom plate as shown in the figure and turn the loading-pully shaft counter-clockwise, then the disctable will push out slowly.
- Caution on closing the disctable.
The disctable cannot be stored thoroughly in the cabinet, when the optical block is under a chucking state. To recover from the chucking state, turn the driver through the B hole gradually and close the disctable.

REMOVAL OF DISCTABLE

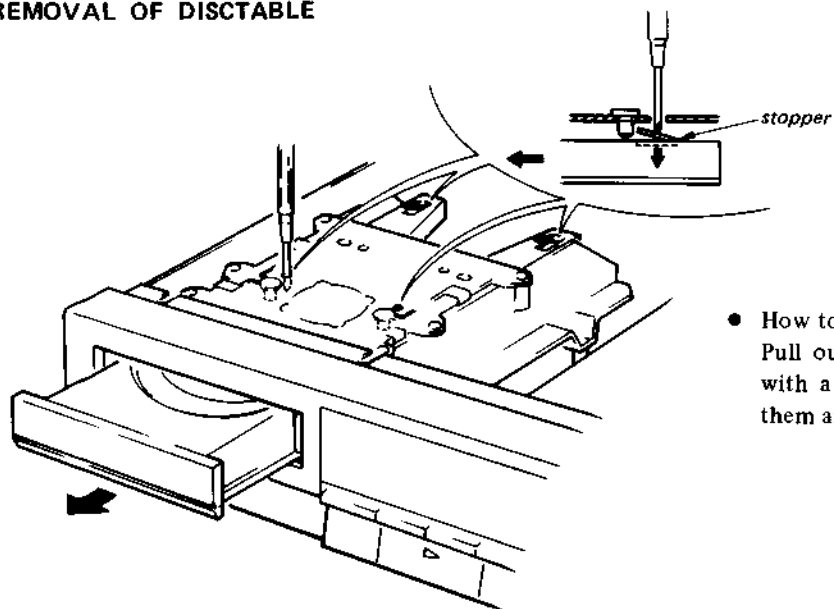

- How to remove the disctable.
Pull out the disctable fully. Press the stoppers down with a precision driver to release the disctable from them and remove it.

NOTES ON HANDLING THE OPTICAL PICK-UP BLOCK OR BASE UNIT

The laser diode in the optical pick-up block may suffer electrostatic breakdown because of the potential difference generated by the charged electrostatic load, etc. on clothing and the human body. During repair, pay attention to electrostatic breakdown and also use the procedure in the printed matter which is included in the repair parts. The flexible board is easily damaged and should be handled with care.

SECTION 2 ADJUSTMENTS

ELECTRICAL ADJUSTMENTS

1. Perform adjustments in the order given.
2. Use YEDS-18 (8-702-101-01) disc unless otherwise indicated.
3. Use the oscilloscope with more than 10 MΩ impedance.

Adjustment Mode

1. Connect main board test point ADJ and GND.
(This is to prevent the disc table from opening even though pits are not read, by making micro-computer IC301 pin ⑧ low.)
2. Turn POWER switch on.
(To reset microcomputer.)
After adjustment, remove the lead wire connecting test points ADJ and GND.
Adjustment Location: main board

Focus Bias Adjustment

This adjustment should be made when replacing optical pick-up.

Procedure:

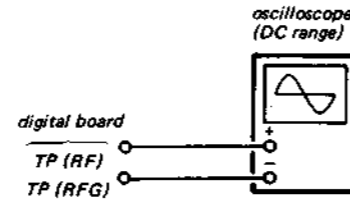

1. Connect oscilloscope to test points RF and RFG.
2. Put set into adjustment mode.
3. Turn POWER switch on.
4. Put disc (YEDS-18) in and press ► button.
5. Adjust RV104 for an optimum waveform eye pattern or so that the peak is maximum. Optimum eye pattern means that shape "◇" can be clearly distinguished at the center of the waveform.

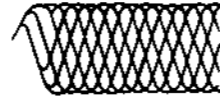

Adjustment Location: main board

RF PLL Adjustment

Procedure:

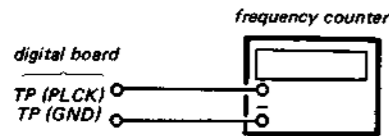

1. Connect main board test point ASY and GND.
2. Connect the frequency counter to main board test points TP PLCK and TP GND.
3. Turn POWER switch ON (stop mode).
4. Adjust main board RV201 so that reading on frequency counter is 4.3218 MHz ± 3 kHz.
5. Reconnect lead wires connected in adjustment mode.
6. Put disc (YEDS-18) in and press ► PLAY button.
7. Confirm that reading on frequency counter is 4.3218 MHz.

Adjustment Location: main board

E-F Balance Adjustment

This adjustment should be made when replacing optical pick-up.

Procedure:

1. Connect oscilloscope to test points TEO and GND.
2. Put set into adjustment mode.
3. Connect TP(TES) to ground.
4. Turn POWER switch on.
5. Put disc (YEDS-18) in and press ► button.
6. Adjust RV101 so that the traverse waveform is symmetrical above and below.
7. After adjustment, cancel the adjustment mode.

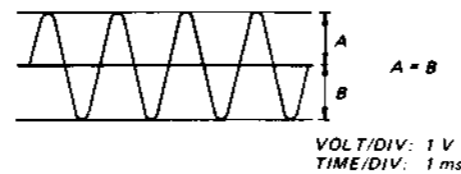

REFERENCE

Focus/Tracking Gain Adjustment

A frequency response analyzer is necessary in order to perform this adjustment exactly.

However, this gain has a margin, so even if it is slightly off, there is no problem. Therefore, do not perform this adjustment.

Focus/tracking gain determines the pick-up follow-up (vertical and horizontal) relative to mechanical noise and mechanical shock when the 2-axis device operate.

However, as these reciprocate, the adjustment is at the point where both are satisfied.

- When gain is raised, the noise when the 2-axis device operates increases.
- When gain is lowered, it is more susceptible to mechanical shock and skipping occurs more easily.
- When gain adjustment is off, the symptoms below appear.

Symptoms	Gain	Focus	Tracking
• The time until music starts becomes longer for STOP → ►PLAY or automatic selection (◀◀ ▶▶ buttons pressed. (Normally takes about 2 seconds.)		low	low or high
• Music does not start and disc continues to rotate for STOP → ►PLAY or automatic selection (◀◀ ▶▶ buttons pressed.)		—	low
• Disc table opens shortly after STOP → ►PLAY.		low or high	—
• Sound is interrupted during PLAY. Or time counter display stops progressing.		—	low
• More poise during 2-axis device operation.	high	high	high

The following is a simple adjustment method.

Simple Adjustment

Note: Since exact adjustment cannot be performed, remember the positions of the controls before performing the adjustment. If the positions after the simple adjustment are only a little different, return the controls to the original position.

Procedure:

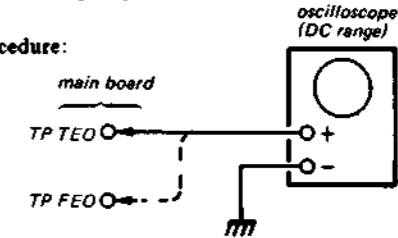

1. Keep the set horizontal.
(If the set is not horizontal, this adjustment cannot be performed due to the gravity against the 2 axis device.)
2. Put set in adjustment mode.
3. Insert disc (YEDS-1) and press ► PLAY button.
4. Connect oscilloscope servo board TP FEO.
5. Adjustment RV203 so that the waveform is as shown in the figure below. (focus gain adjustment)

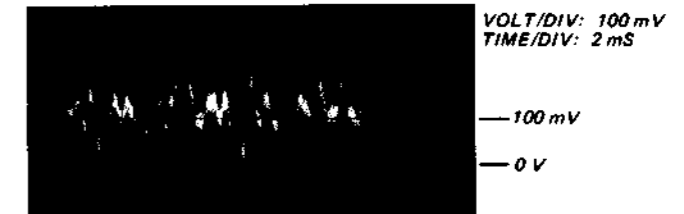

- Inccornt Examples (DC level changes more than on adjusted waveform)

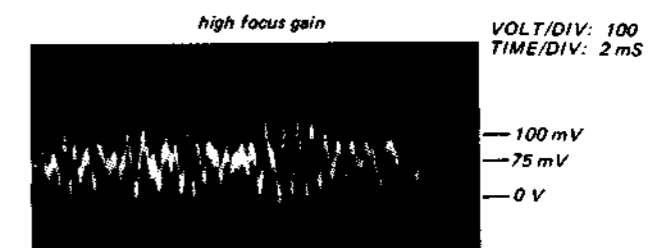
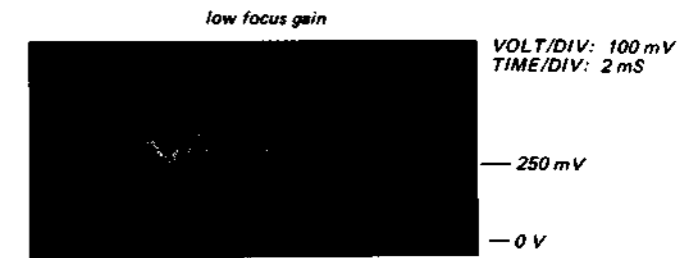

REFERENCE

Focus/Tracking Gain Adjustment

A frequency response analyzer is necessary in order to perform this adjustment exactly.

However, this gain has a margin, so even if it is slightly off, there is no problem. Therefore, do not perform this adjustment.

Focus/tracking gain determines the pick-up follow-up (vertical and horizontal) relative to mechanical noise and mechanical shock when the 2-axis device operate.

However, as these reciprocate, the adjustment is at the point where both are satisfied.

- When gain is raised, the noise when the 2-axis device operates increases.
- When gain is lowered, it is more susceptible to mechanical shock and skipping occurs more easily.
- When gain adjustment is off, the symptoms below appear.

Symptoms	Gain	Focus	Tracking
• The time until music starts becomes longer for STOP → PLAY or automatic selection (▶◀▶▶) buttons pressed. (Normally takes about 2 seconds.)		low	low or high
• Music does not start and disc continues to rotate for STOP → PLAY or automatic selection (▶◀▶▶) buttons pressed.)		-	low
• Disc table opens shortly after STOP → PLAY.		low or high	-
• Sound is interrupted during PLAY. Or time counter display stops progressing.		-	low
• More noise during 2-axis device operation.		high	high

The following is a simple adjustment method.

Simple Adjustment -

Note: Since exact adjustment cannot be performed, remember the positions of the controls before performing the adjustment. If the positions after the simple adjustment are only a little different, return the controls to the original position.

Procedure:



1. Keep the set horizontal.
(If the set is not horizontal, this adjustment cannot be performed due to the gravity against the 2 axis device.)
2. Put set in adjustment mode.
3. Insert disc (YEDS-1) and press ▶ PLAY button.
4. Connect oscilloscope servo board TP FEO.
5. Adjustment RV203 so that the waveform is as shown in the figure below. (focus gain adjustment)

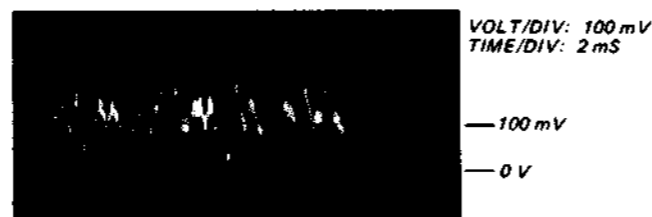

• Incorrect Examples (DC level changes more than on adjusted waveform)



high focus gain

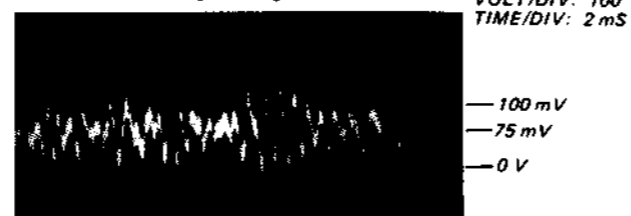

6. Connect oscilloscope to main board TP TEO.
7. Adjust RV304 so that the waveform is as shown in the figure below. (tracking gain adjustment)



• Incorrect Examples (fundamental wave appears)

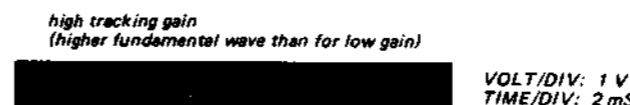

Adjustment Location: main board

Adjustment Location: main board

[MAIN BOARD] -mounted side-

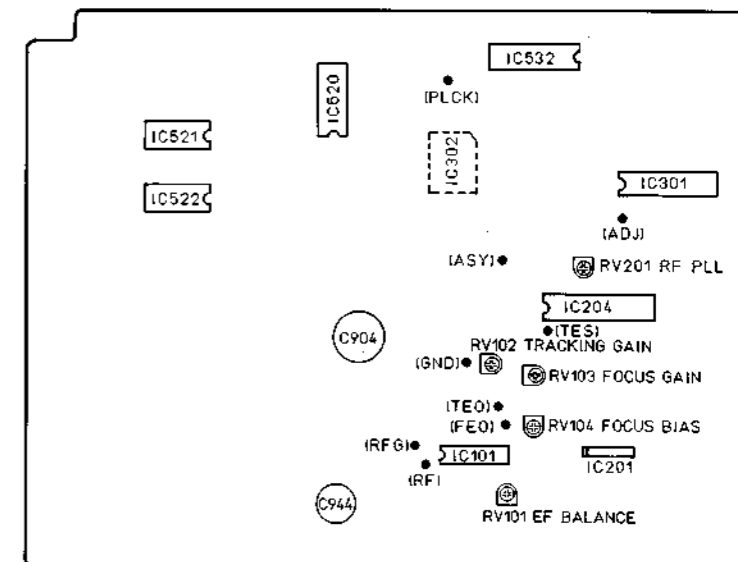

SECTION 3
DIAGRAMS

3-1. IC BLOCK DIAGRAMS

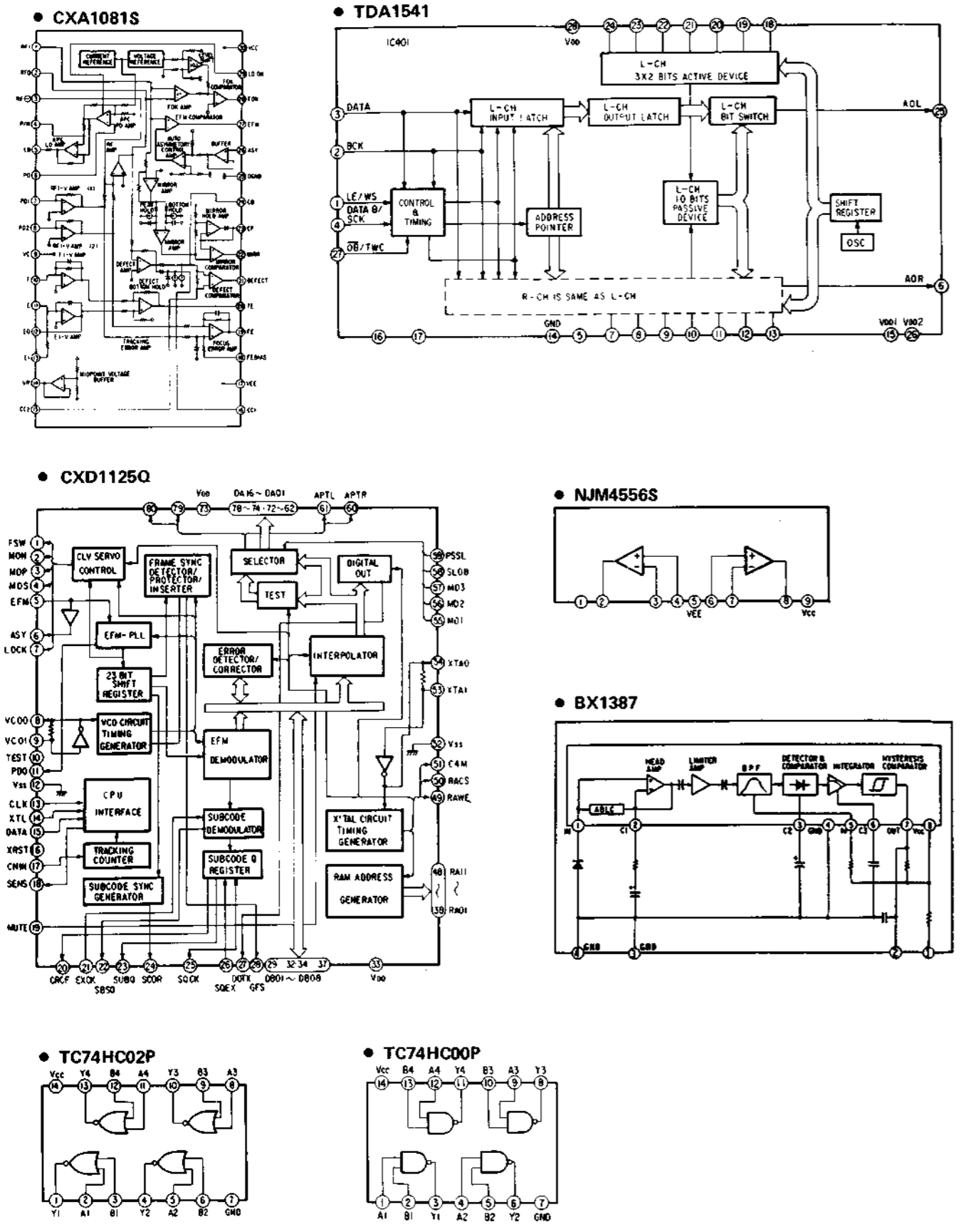

3-2. BLOCK DIAGRAM

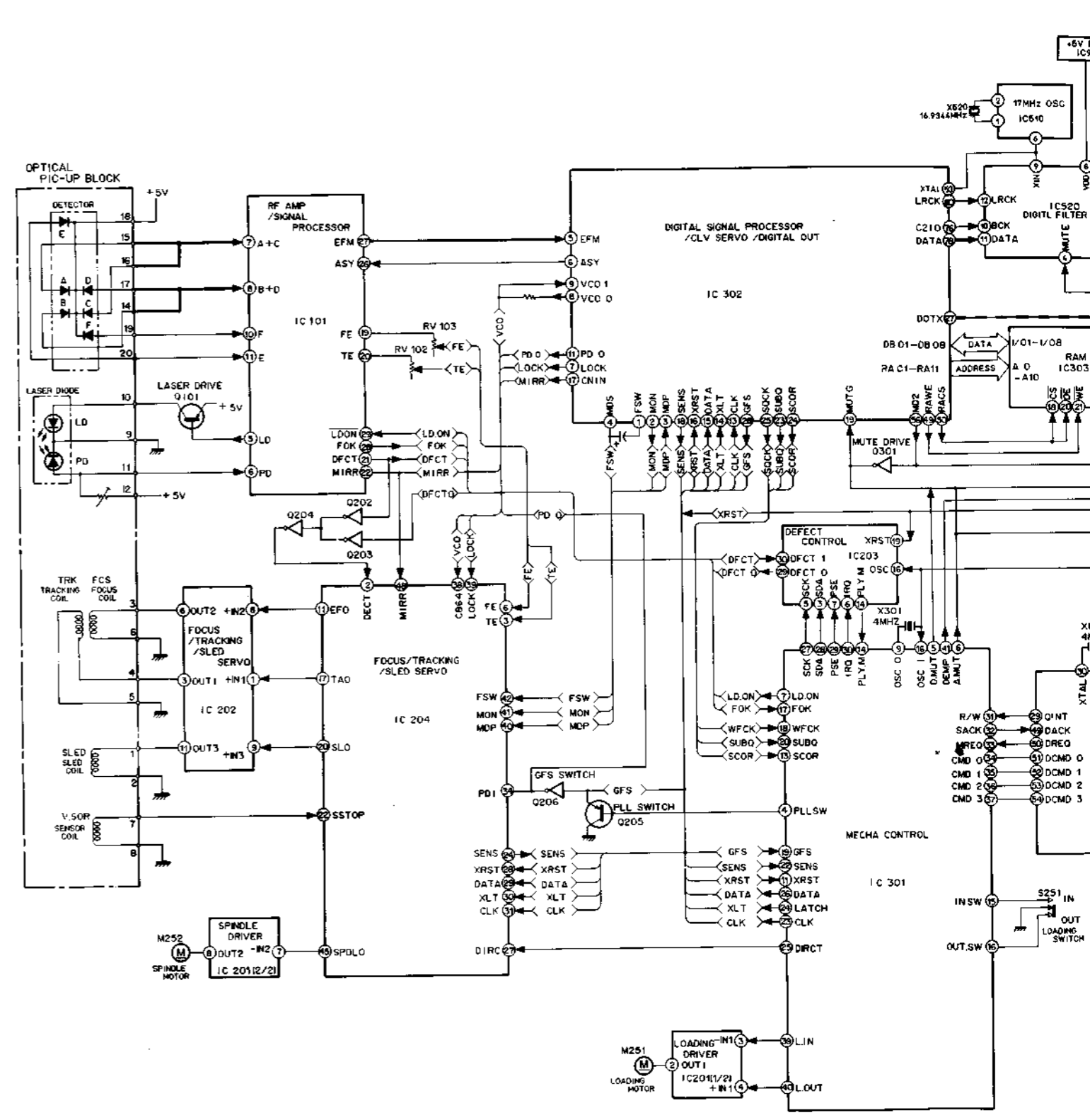

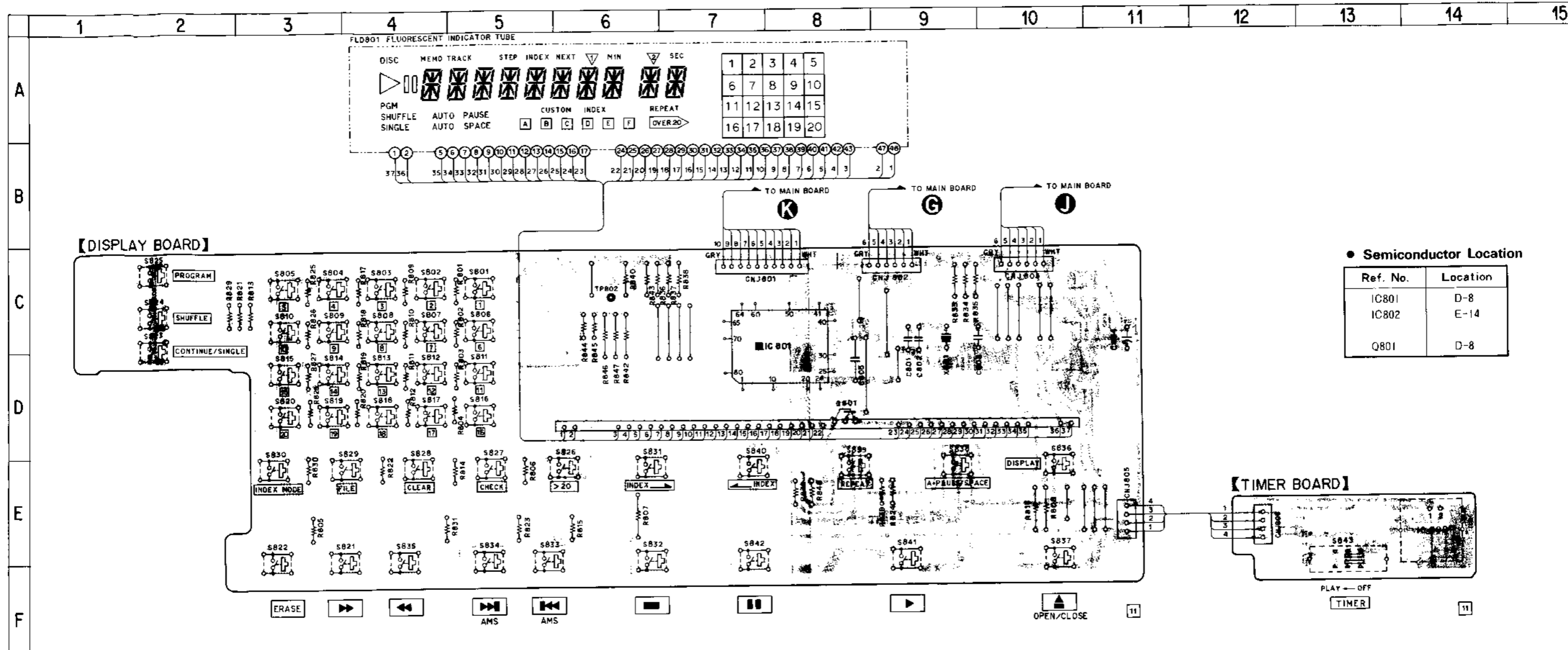

• Semiconductor Location

Ref. No.	Location
IC801	D-8
IC802	E-14
Q801	D-8

3-4. SEMICONDUCTOR LEAD LAYOUTS

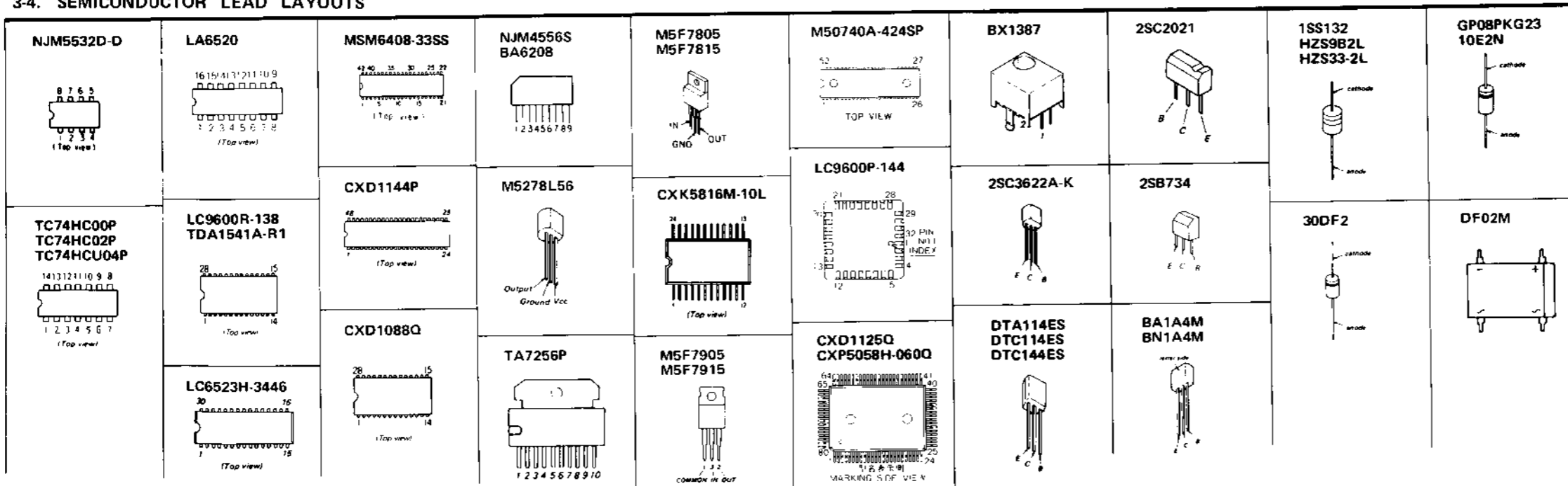

• CIRCUIT BOARDS LOCATION

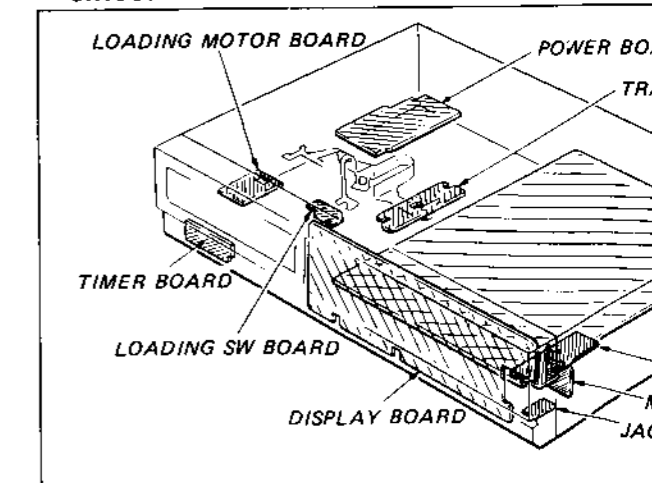

8 9 10 11 12 13 14 15

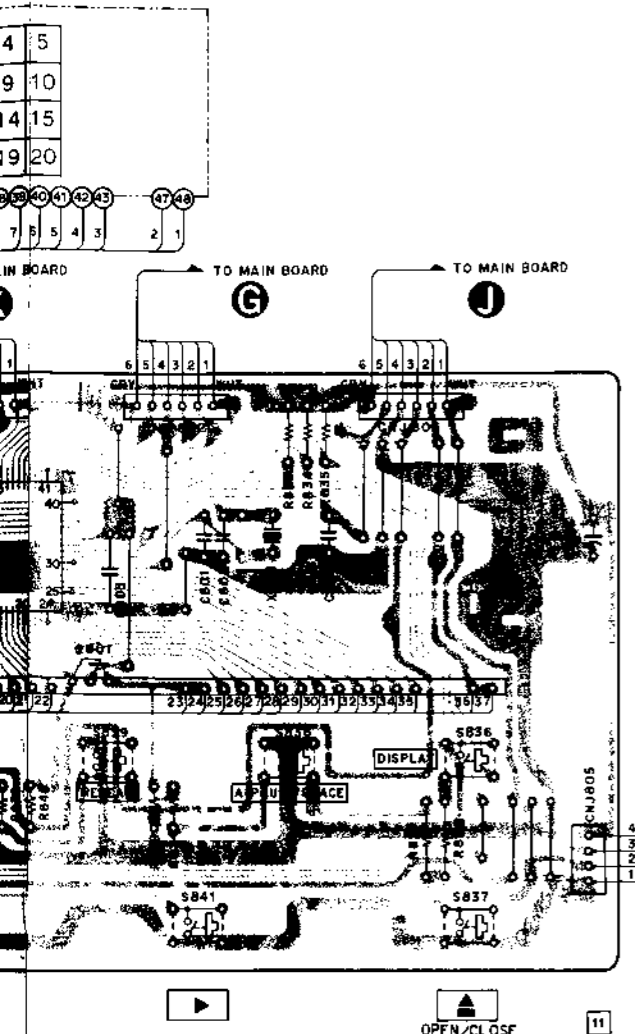

● Semiconductor Location

Ref. No.	Location
IC801	D-8
IC802	E-14
O801	D-8

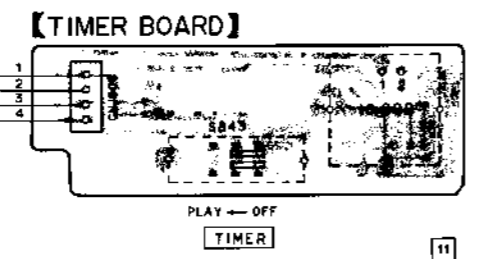

● CIRCUIT BOARDS LOCATION

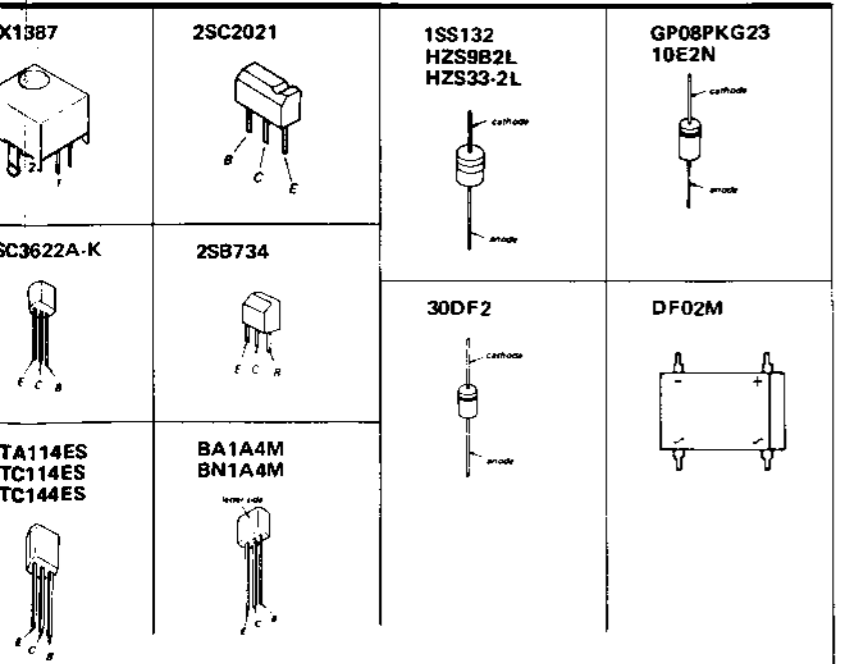
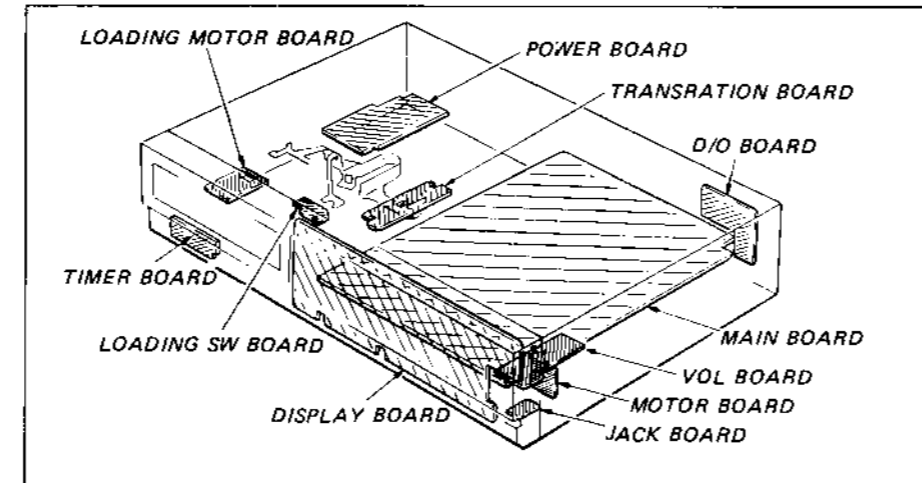

3-5. SCHEMATIC DIAGRAM
- Display Section -

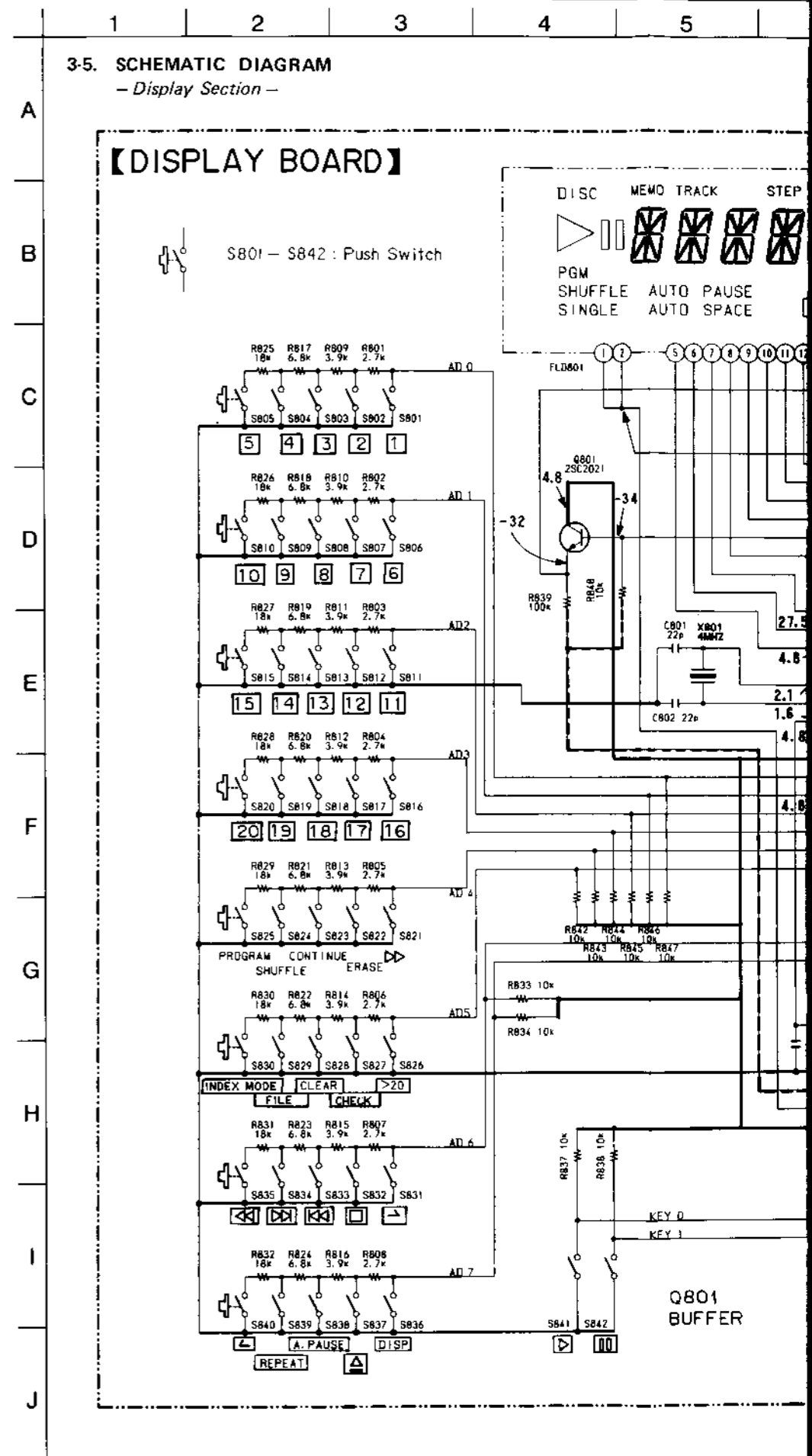

3-5. SCHEMATIC DIAGRAM
- Display Section -

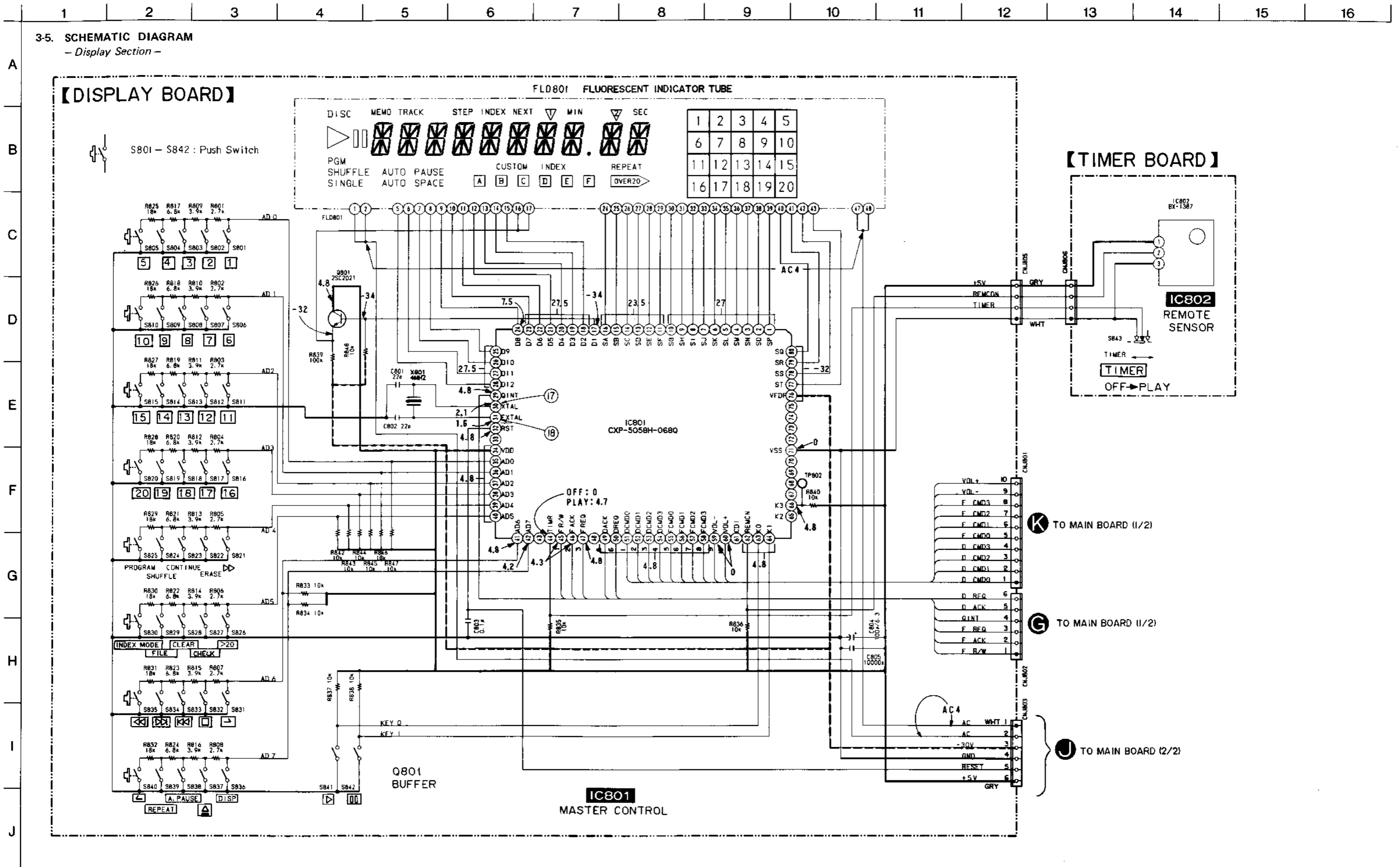

3-6. WAVEFORMS

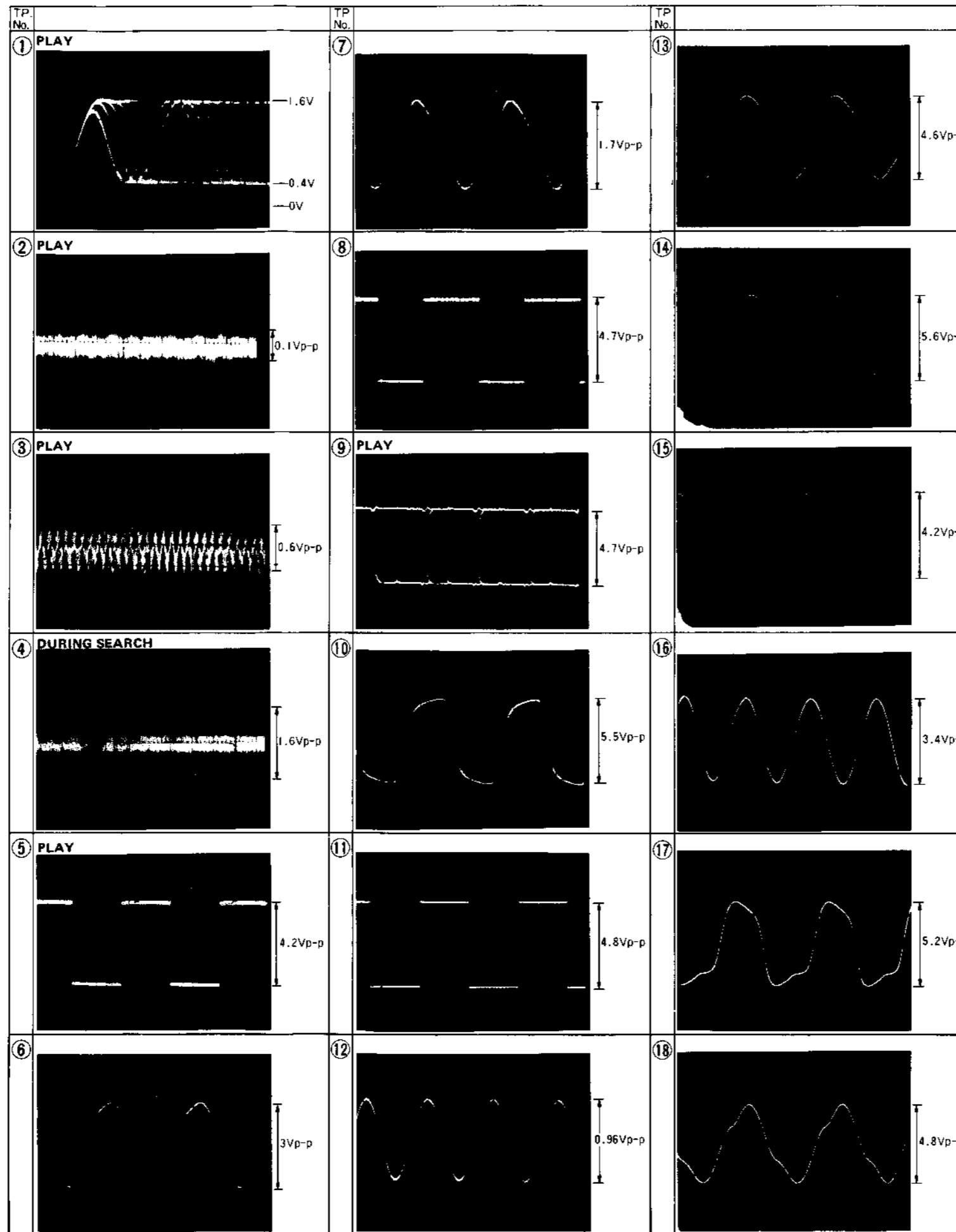

3-7. PRINTED WIRING BOARDS
- Main Section -

• Semiconductor Location

Ref. No.	Location	Ref. No.	Location
D101	I-10	IC391	D-2
D201	H-6	IC400	D-14
D500	D-15	IC450	D-2
D900	I-14	IC500	E-14
D901	I-14	IC510	D-11
D902	I-14	IC520	C-11
D903	G-13	IC521	C-13
D904	G-12	IC522	E-13
D920	H-15	IC900	H-13
D921	H-16	IC904	F-13
D922	H-15	IC910	I-13
D923	H-15	IC920	G-15
D940	I-12	IC921	F-11
D941	I-13	IC922	C-12
D942	I-13	IC930	G-15
D943	J-12	IC931	E-12
D944	I-11	-	-
D945	I-12	Q101	I-9
-	-	Q202	H-6
IC101	H-10	Q203	H-6
IC201	I-7	Q204	H-6
IC202	H-8	Q205	F-7
IC203	G-6	Q206	F-7
IC204	F-8	Q301	D-8
IC301	D-7	Q400	C-14
IC302	D-10	O500	G-14
IC303	E-10	O520	F-11
IC351	C-7	O521	G-14
IC352	C-9	O522	F-11
IC380	B-13	O940	I-12

• CIRCUIT BOARDS LOCATION

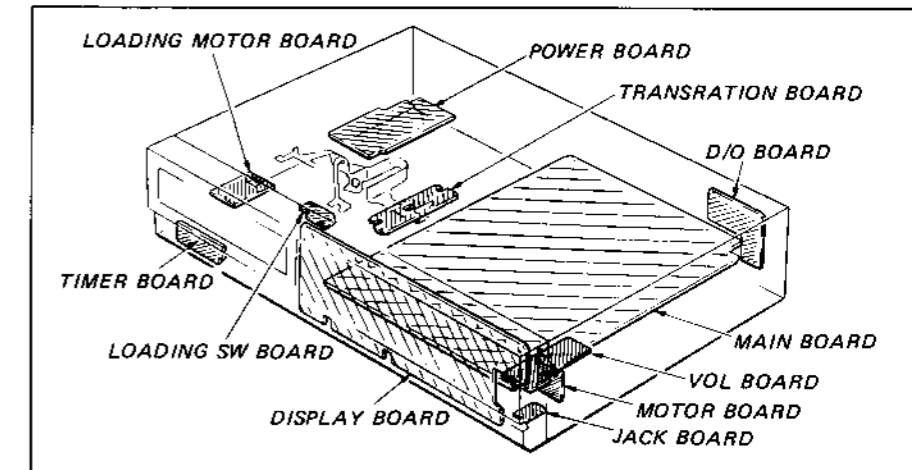

Note:

- ○ : parts extracted from the component side.
- ● : parts extracted from the conductor side.
- ■ : parts mounted on the conductor side.
- ○—○ : Jumper wire connected to the ground pattern on the component side.
- ■ : Pattern on the side which is seen.

3-7. PRINTED WIRING BOARDS
— Main Section —

● Semiconductor Location

Ref. No.	Location	Ref. No.	Location
D101	I-10	IC391	D-2
D201	H-6	IC400	D-14
D500	D-15	IC450	D-2
D900	I-14	IC500	E-14
D901	I-14	IC510	D-11
D902	I-14	IC520	C-11
D903	G-13	IC521	C-13
D904	G-12	IC522	E-13
D920	H-15	IC900	H-13
D921	H-16	IC904	F-13
D922	H-15	IC910	I-13
D923	H-15	IC920	G-15
D940	I-12	IC921	F-11
D941	I-13	IC922	C-12
D942	I-13	IC930	G-15
D943	J-12	IC931	E-12
D944	I-11	—	—
D945	I-12	Q101	I-9
—	—	Q202	H-6
IC101	H-10	Q203	H-6
IC201	I-7	Q204	H-6
IC202	H-8	Q205	F-7
IC203	G-6	Q206	F-7
IC204	F-8	Q301	D-8
IC301	D-7	Q400	C-14
IC302	D-10	Q500	G-14
IC303	E-10	Q520	F-11
IC351	C-7	Q521	G-14
IC352	C-9	Q522	F-11
IC380	B-13	Q940	I-12

● CIRCUIT BOARDS LOCATION

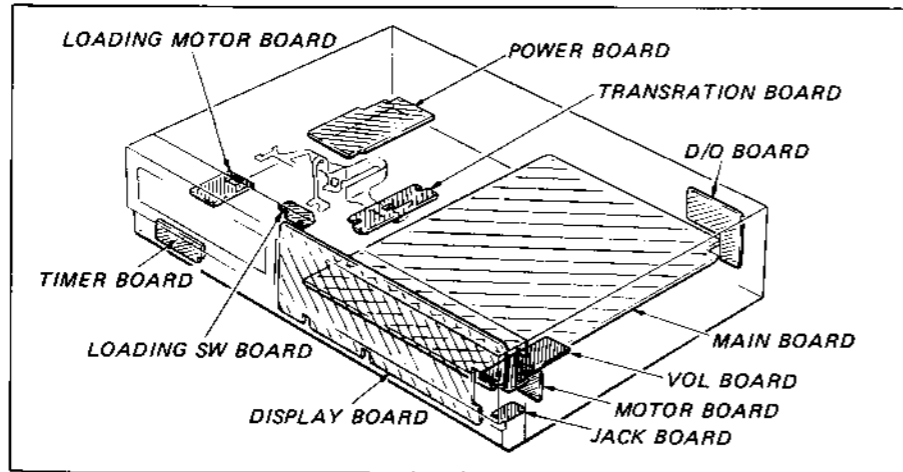

- Note:**
- : parts extracted from the component side.
 - : parts extracted from the conductor side.
 - : parts mounted on the conductor side.
 - : Jumper wire connected to the ground pattern on the component side.
 - /// : Pattern on the side which is seen.

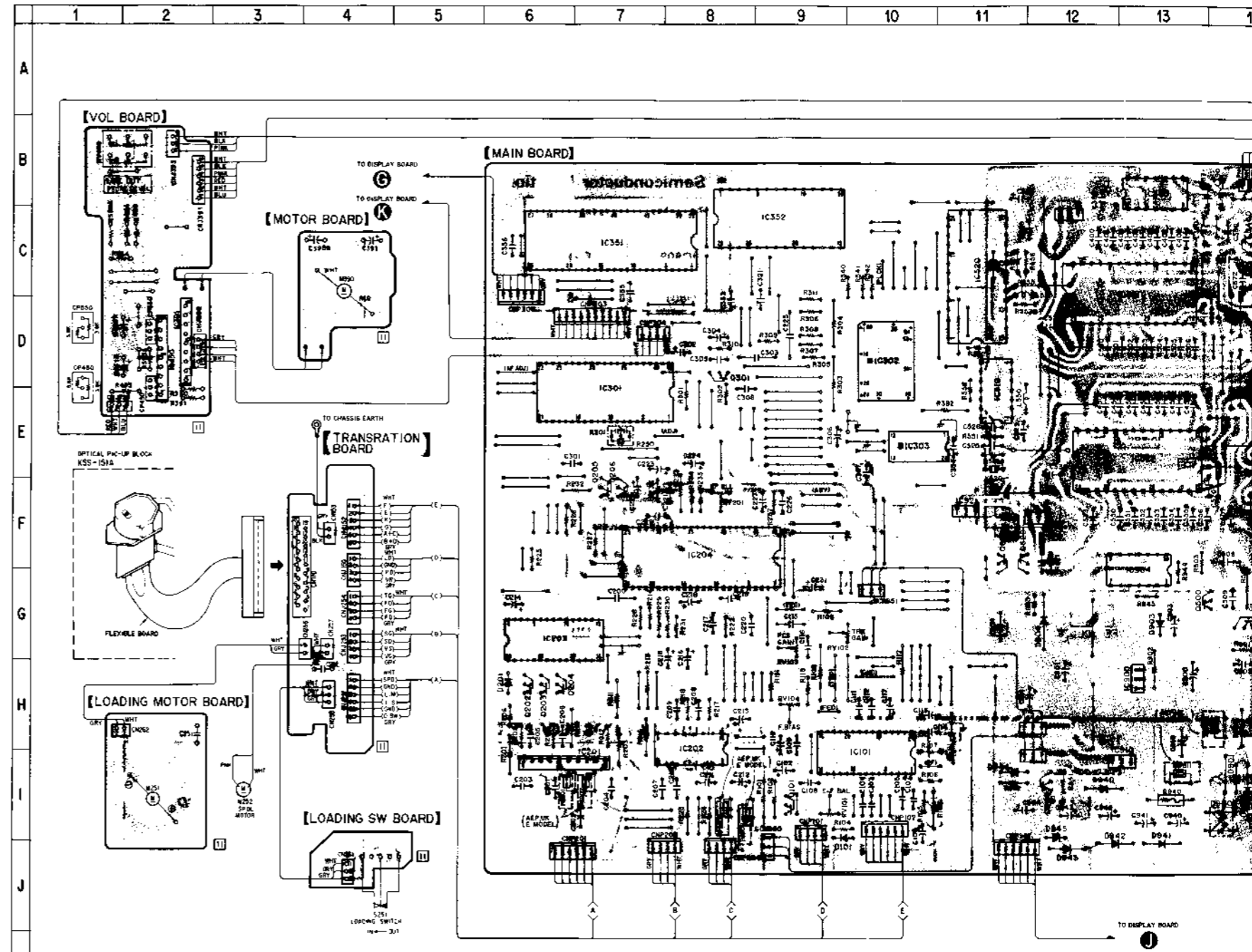

3-8. SCHEMATIC DIAGRAM • See page 28 for note.
- Main Section (1/2) -

- Signal path
- ◊ : CD
- ◻ : digital out

[MAIN BOARD (1/2)]

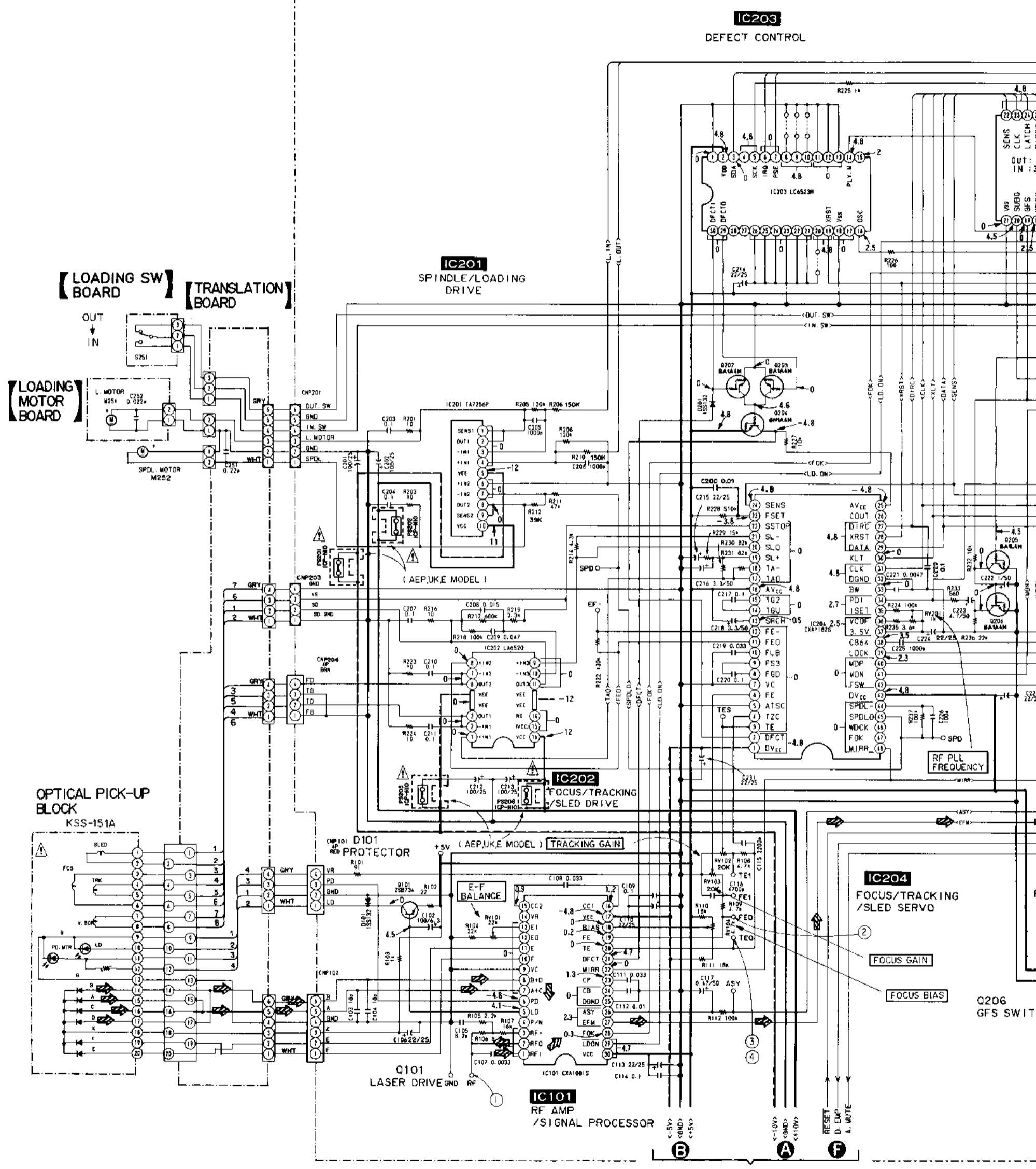

TO MAIN BOARD (2/2)

A
B
C
D
E
F
G
H
I
J
K
L
M
N
O
P

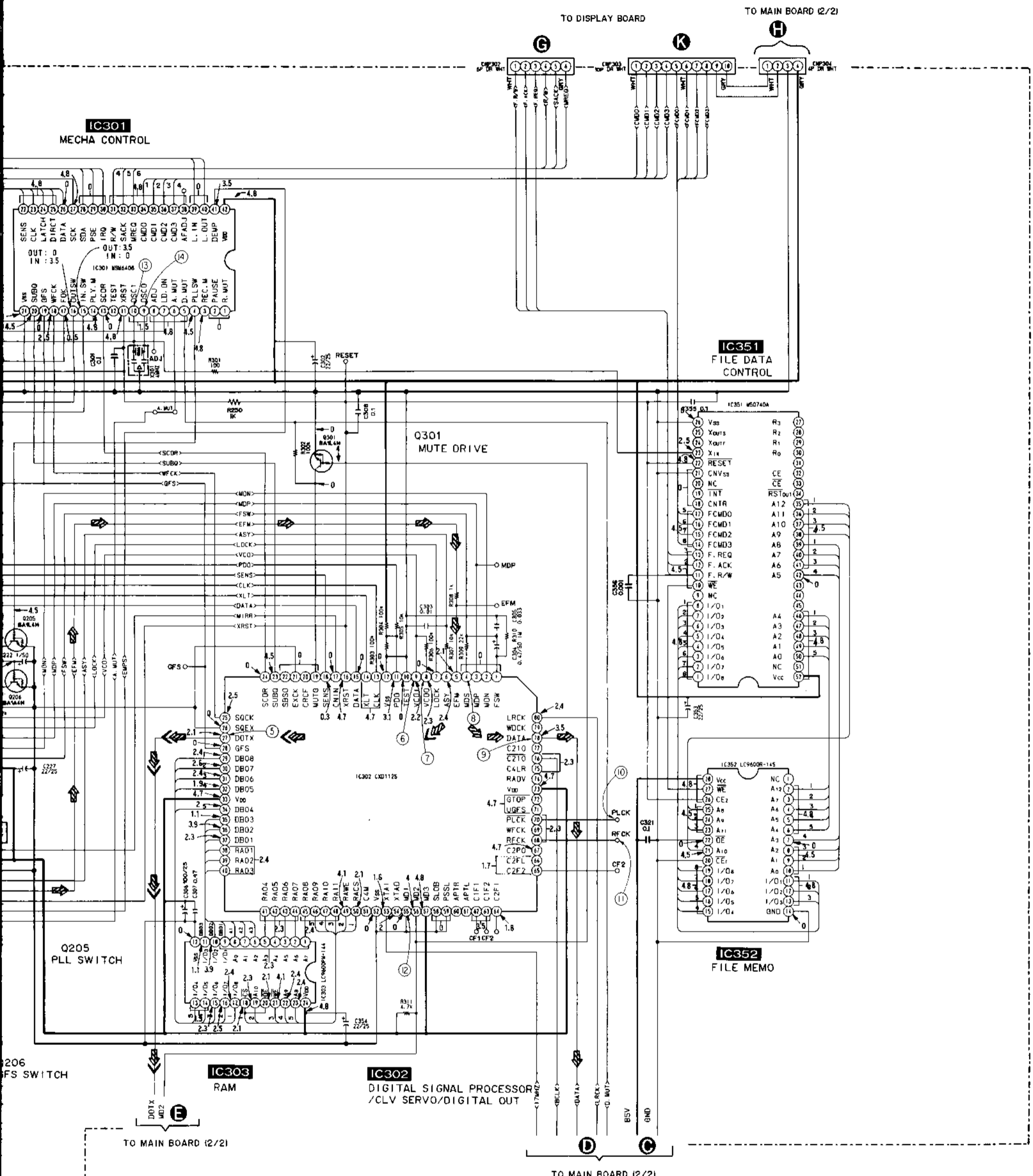

3-9. SCHEMATIC DIAGRAM
- Main Section (2/2) -

【MAIN BOARD (2/2)】

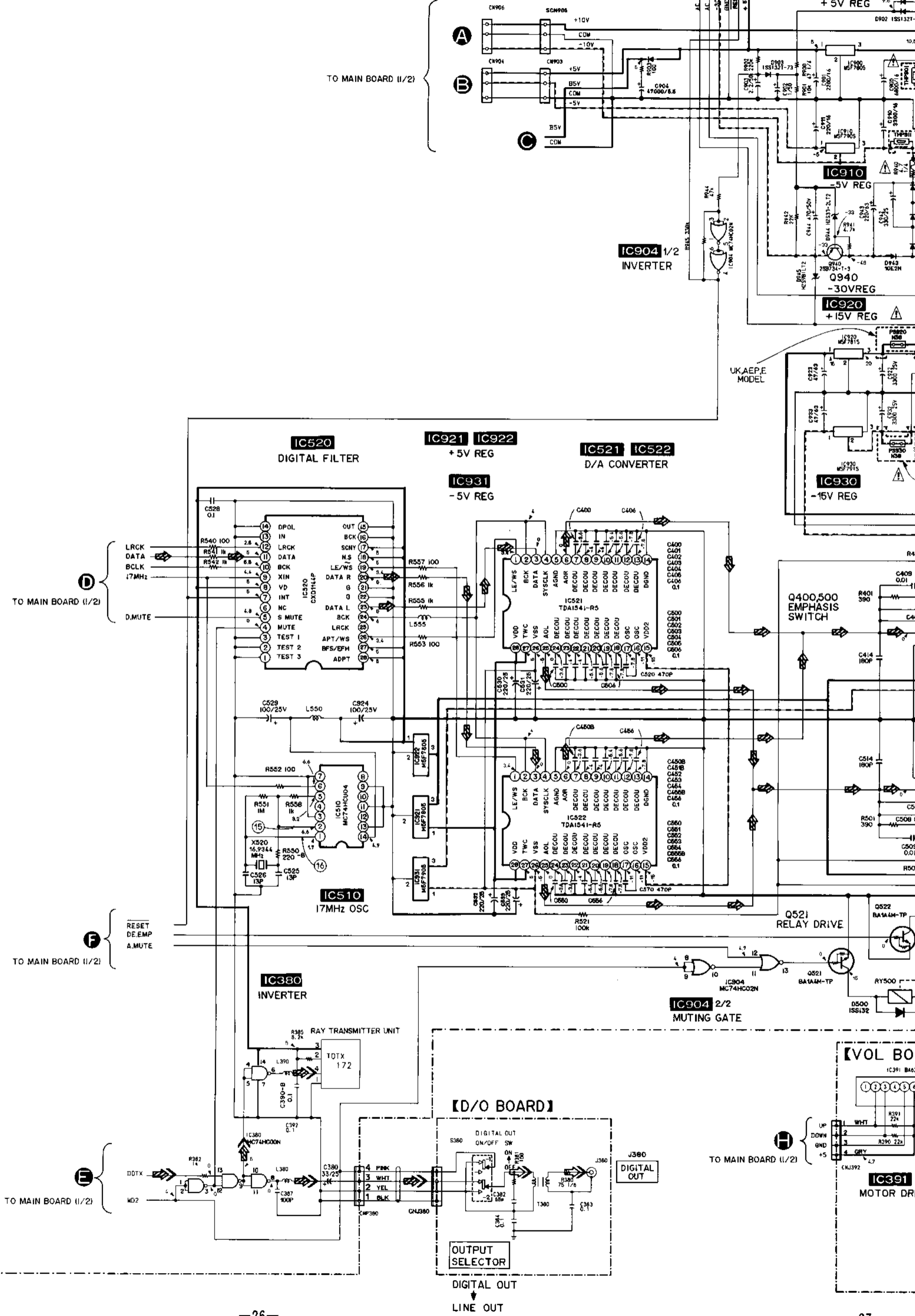

A
B
C
D
E
F
G
H
I
J
K
L
M
N
O
P

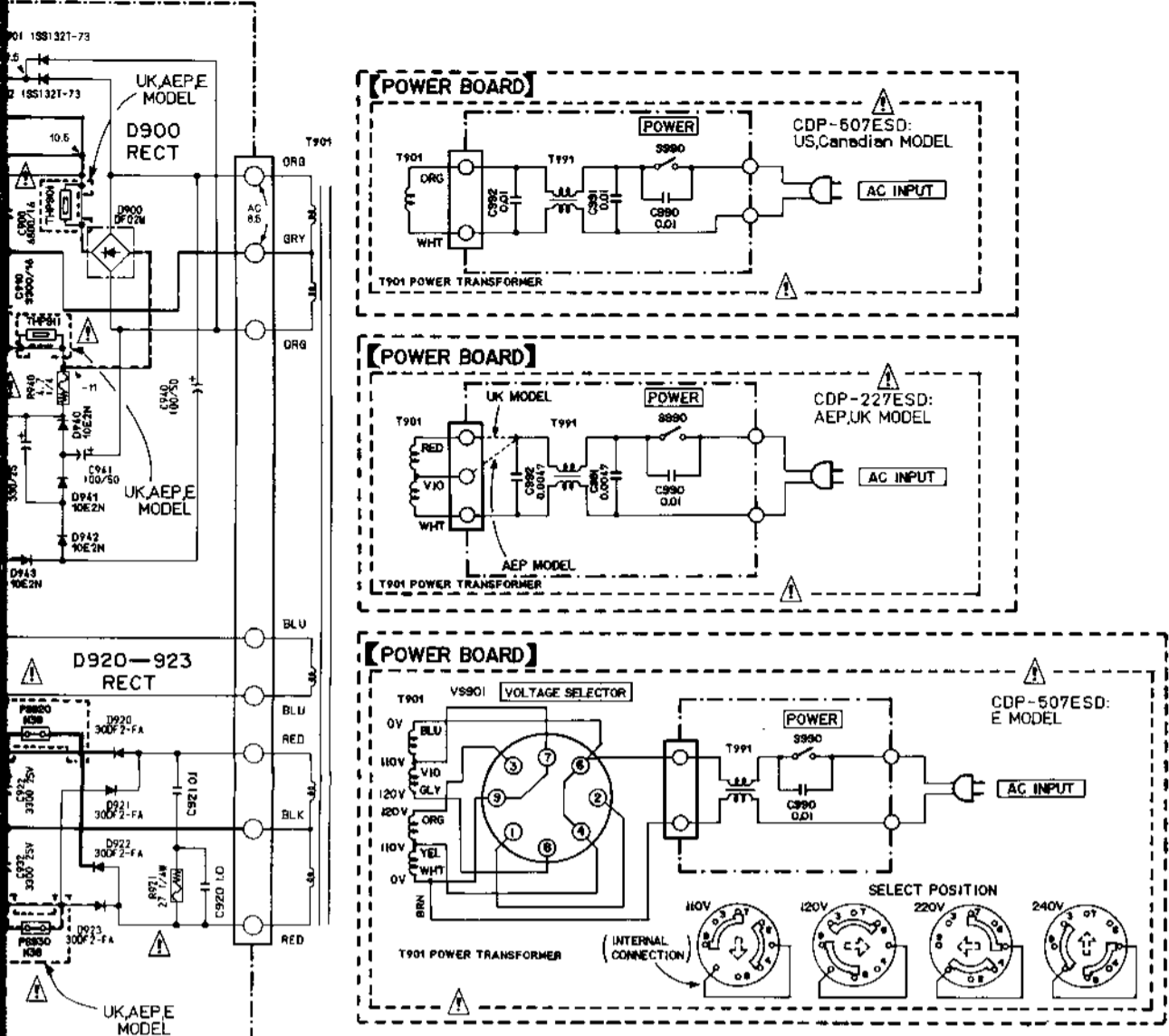

- Note:**
- All capacitors are in μF unless otherwise noted. pF : μpF 50WV or less are not indicated except for electrolytics and tantalums.
 - All resistors are in Ω and $1/4\text{W}$ or less unless otherwise specified.
 - Δ : internal component.
 - --- : fusible resistor.
 - --- : B+ lin.
 - --- : B- lin.
 - --- : adjustment for repair.
 - Voltage and waveforms are dc with respect to ground under no-signal conditions.
 - no mark: STOP
 - Voltages are taken with a VOM (50k Ω /V). Voltage variations may be noted due to normal production tolerances.
 - Waveforms are taken to grow by using oscilloscope.
 - Voltage variations may be noted due to normal production tolerances.
 - Circled numbers refer to waveforms. (See page 18.)
 - Signal path.
 - --- : CD
 - --- : digital out
 - Switches:

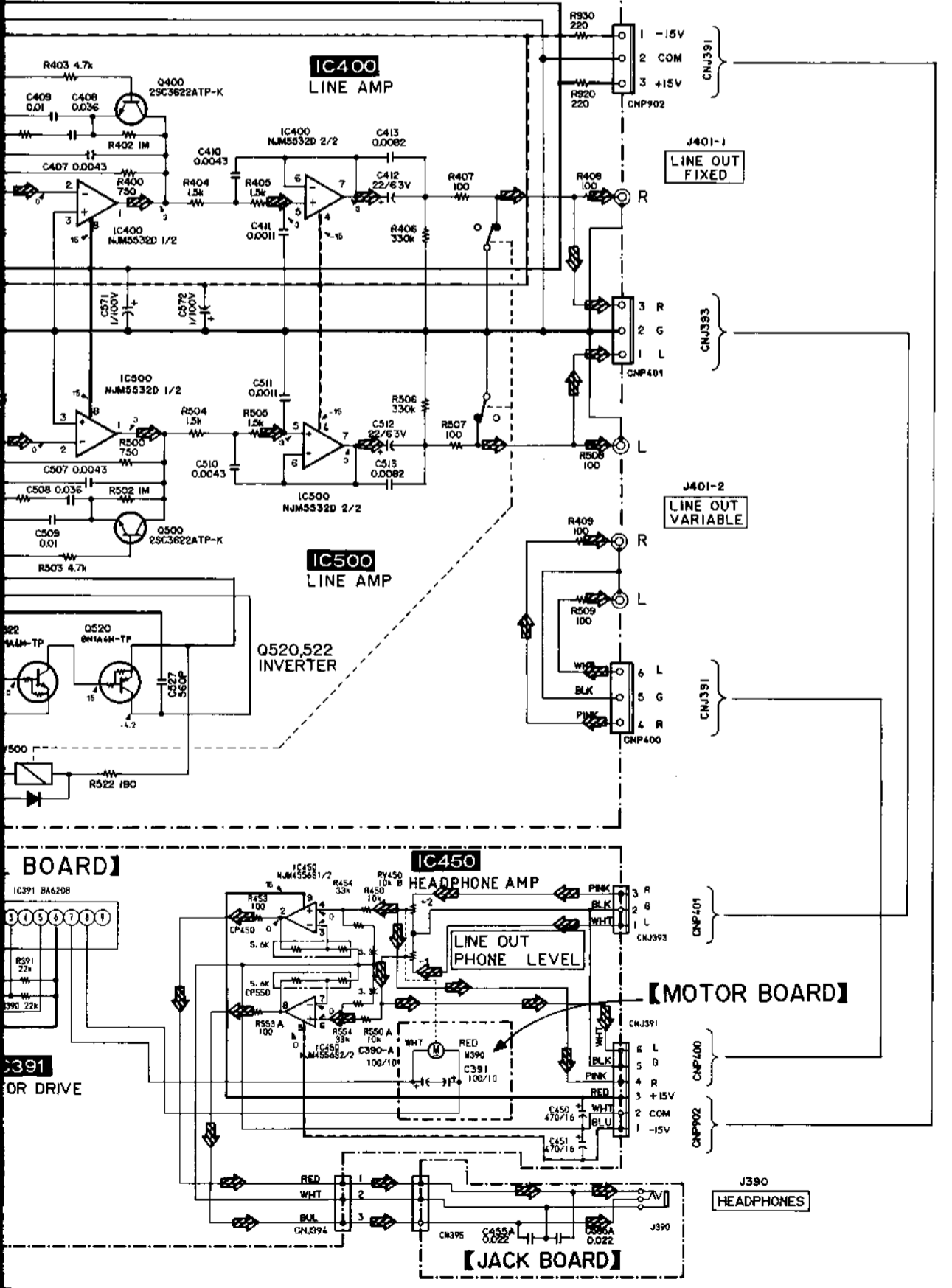

Ref. No.	Switch	Position
S251	LOADING SWITCH	OUT
S380	OUTPUT SELECTOR	DIGITAL
S801	1	OFF
S802	2	OFF
S803	3	OFF
S804	4	OFF
S805	5	OFF
S806	6	OFF
S807	7	OFF
S808	8	OFF
S809	9	OFF
S810	10	OFF
S811	11	OFF
S812	12	OFF
S813	13	OFF
S814	14	OFF
S815	15	OFF
S816	16	OFF
S817	17	OFF
S818	18	OFF
S819	19	OFF
S820	20	OFF
S821	\blacktriangleright	OFF
S822	ERASE	OFF
S823	CONTINUE/SINGLE	OFF
S824	SHUFFLE	OFF
S825	PROGRAM	OFF
S826	>20	OFF
S827	CHECK	OFF
S828	CLEAR	OFF
S829	FILE	OFF
S830	INDEX MODE	OFF
S831	INDEX \rightarrow	OFF
S832	\blacksquare	OFF
S833	AMS \leftarrow	OFF
S834	AMS \rightarrow	OFF
S835	\leftarrow	OFF
S836	DISPLAY	OFF
S837		OFF
S838	A-PAUSE	OFF
S839	REPEAT	OFF
S840	INDEX \leftarrow	OFF
S841	\blacktriangleright	OFF
S842	\blacksquare	OFF
S843	TIMER	OFF
S990	POWER	OFF
VS901 (E model)	VOLTAGE SELECTOR	-

Note: The components identified by mark Δ or dotted line with mark Δ are critical for safety. Replace only with part number specified.

**SECTION 4
EXPLODED VIEWS**

NOTE:

- The mechanical parts with no reference number in the exploded views are not supplied.
- The construction parts of an assembled part are indicated with a collation number in the remark column.
- Items marked "*" are not stocked since they are seldom required for routine service. Some delay should be anticipated when ordering these items.

- Due to standardization, parts with part number suffix -XX and -X may be different from the parts specified in the components used on the set.
- Color Indication of Appearance Parts
Example:
(RED) ... KNOB, BALANCE (WHITE)
↑ Cabinet's Color ↑ Parts' Color

The components identified by mark or dotted line with mark are critical for safety. Replace only with part number specified.

Les composants identifiés par une marque sont critiques pour la sécurité. Ne les remplacer que par une pièce portant le numéro spécifié.

1. GENERAL

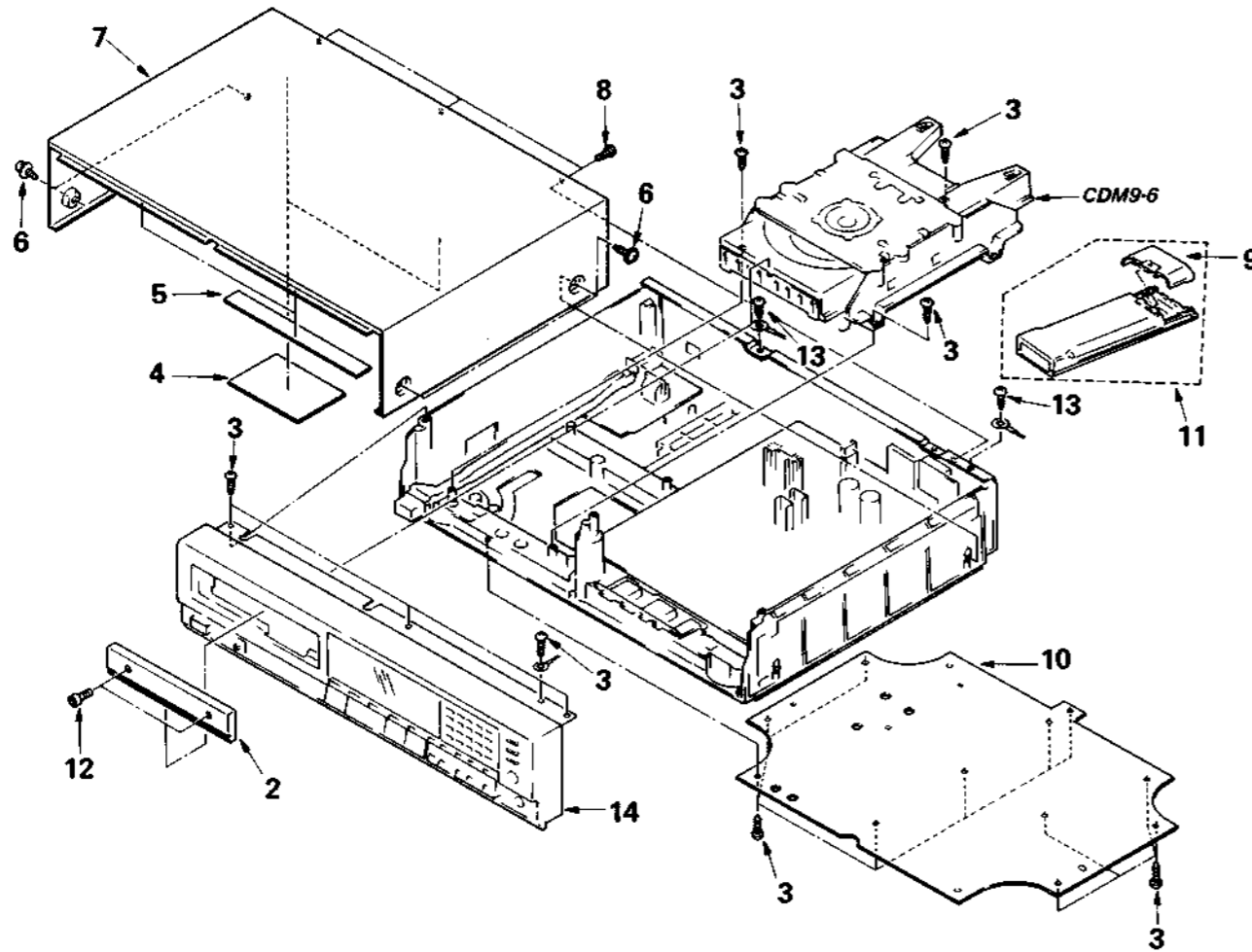

Ref.No	Part No.	Description
2	A-4675-247-A (AEP, UK, E) ...	PANEL ASSY, LOADING
2	A-4675-248-A (US, Canadian) ...	PANEL ASSY, LOADING
3	7-685-647-79	SCREW, TAPPING
4	*4-917-634-01	DAMPER (C)
5	*4-922-422-01	CUSHION (C)
6	7-685-646-79	SCREW, TAPPING
7	4-922-594-01	CASE

Ref.No	Part No.	Description
8	4-886-821-01	SCREW, M3 CASE
9	4-922-528-01	LID, BATTERY CASE, COMMANDER
10	*4-922-927-51	PLATE, BOTTOM
11	1-463-909-11	COMMANDER, REMOTE (RM-D650)
12	4-923-533-01	BOLT (M2.5X3), HEXAGON SOCKET
13	7-685-871-01	SCREW +BVTT 3X6 (S)
14	X-4922-521-2	PANEL ASSY, FRONT

2. CHASSIS

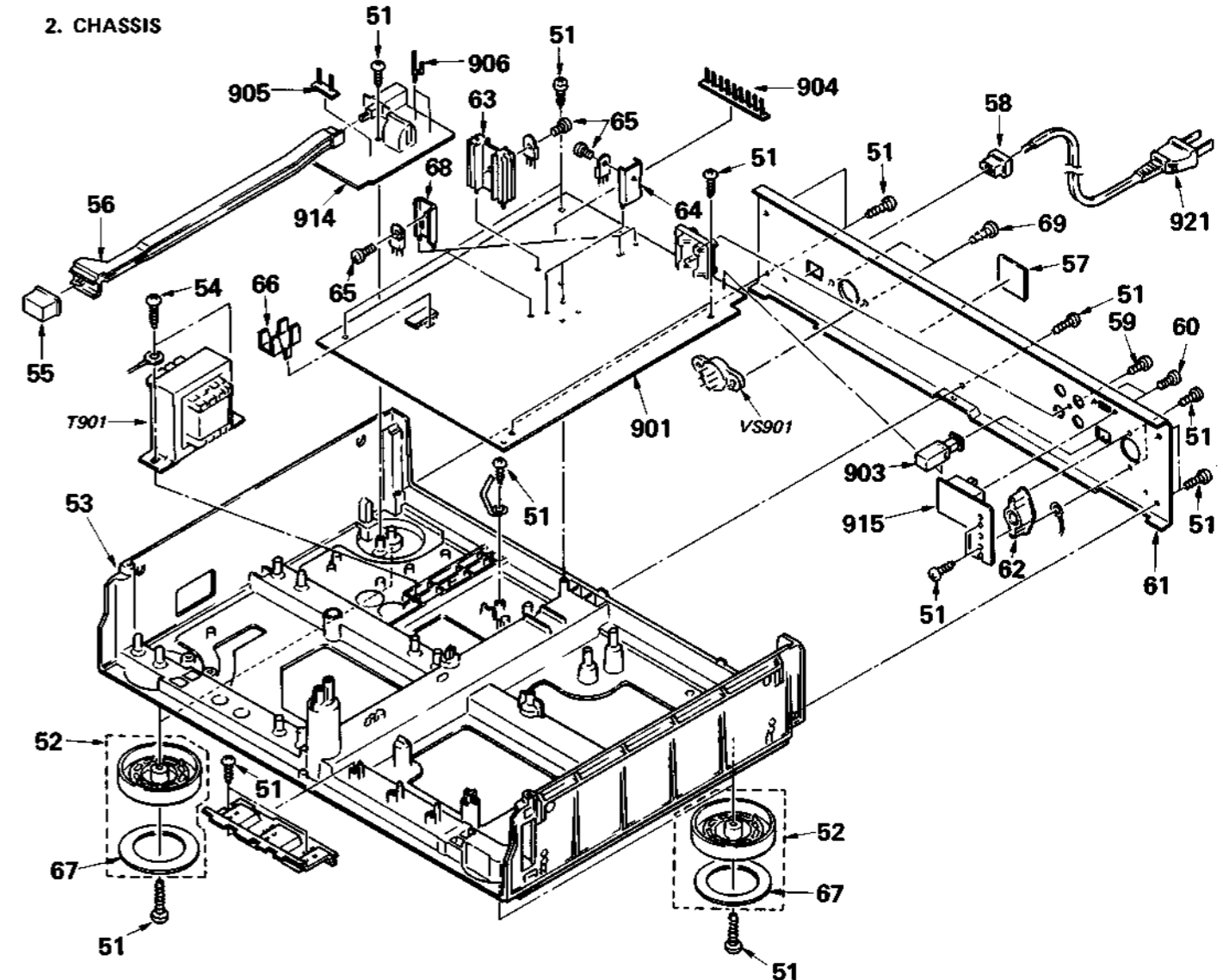

Note:
The components identified by mark or dotted line with mark are critical for safety. Replace only with part number specified.

Note:
Les composants identifiés par une marque sont critiques pour la sécurité. Ne les remplacer que par une pièce portant le numéro spécifié.

Ref.No	Part No.	Description
51	7-685-647-79	SCREW +BVTP 3X10 TYPE2 N-S
52	X-4922-508-1	FOOT ASSY
53	*4-922-928-01	CHASSIS
54	7-685-661-79	SCREW +BVTP 4X12 TYPE2 N-S
55	4-923-520-01	KNOB, POWER
56	*4-922-530-01	LEVER, POWER SWITCH
57	*4-885-838-01	(AEP, UK, E) ... LABEL, CLASS1
58	*3-703-244-00	BUSHING (2104), CORD
59	4-909-982-01	SCREW, TAPPING
60	7-621-775-10	SCREW +B 2.6X4
61	*4-922-505-12 (US) ...	PANEL, BACK
61	*4-922-505-22 (Canadian) ...	PANEL, BACK
61	*4-922-505-32 (UK) ...	PANEL, BACK
61	*4-922-505-42 (AEP) ...	PANEL, BACK
61	*4-922-505-51 (E) ...	PANEL, BACK
62	*4-913-152-01	ESCUTCHEON, D/O
63	*4-908-502-01	HEAT SINK
64	*3-309-144-01	HEAT SINK
65	7-682-147-15	SCREW, TR
66	*4-922-525-01	HEAT SINK

Ref.No	Part No.	Description
67	4-922-915-01	FOOT (FELT)
68	*4-886-555-00	HEAT SINK
69	7-682-547-09 (E) ...	SCREW +BVTT 3X6 (S)
901	*A-4651-177-A (EUK) ...	MOUNTED PCB, MAIN
901	*A-4651-198-A (Canadian, US, AEP) ...	MOUNTED PCB, MAIN
903	1-464-878-11	TRANSMITTER UNIT, RAY
904	*1-535-122-00	TERMINAL
905	*1-535-139-00	BASE POST 19MM (10MM PITCH) 2P
906	*1-535-688-11	TERMINAL
914	*1-626-469-11	PC BOARD, POWER
915	*1-626-470-11	PC BOARD, D/O
921	1-555-795-00 (AEP) ...	CORD, POWER
921	1-556-035-00 (UK) ...	CORD, POWER
921	1-557-577-11 (US, Canadian) ...	CORD, POWER
921	1-558-181-11 (E) ...	CORD, POWER
T901	1-449-285-11 (US, Canadian) ...	TRANSFORMER, POWER
T901	1-449-286-11 (AEP, UK) ...	TRANSFORMER, POWER
T901	1-449-287-11 (E) ...	TRANSFORMER, POWER
VS901	1-526-576-51 (E) ...	SELECTOR, POWER VOLTAGE

3. FRONT PANEL

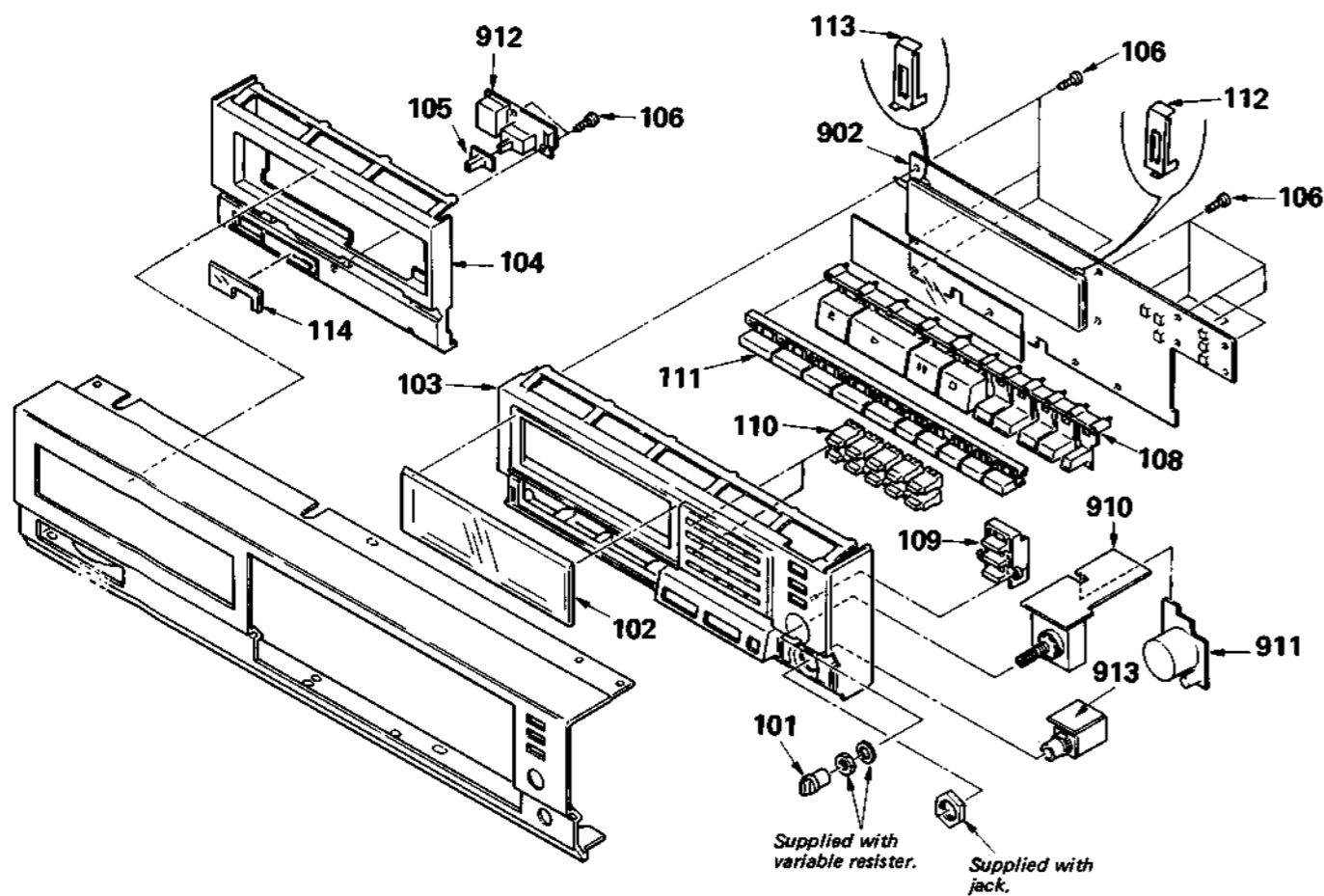

Ref.No	Part No.	Description
101	4-922-531-01	KNOB (A TYPE),VOL
102	4-922-586-01	PLATE, TRANSPARENT
103	4-922-595-01	PANEL (SUB RIGHT)
104	4-922-596-01	PANEL (SUB LEFT)
105	4-922-518-11	KNOB (TIMER)
106	7-685-134-19	SCREW +BTP 2.6X8 TYPE2 N-S
108	4-922-590-01	BUTTON (9 GANG)
109	4-922-591-01	BUTTON (3 GANG)
110	4-922-587-01	BUTTON, 10 GANG

Ref.No	Part No.	Description
111	4-922-592-01	BUTTON (10 GANG)
112	*4-922-523-01	HOLDER (RIGHT)
113	*4-922-524-01	HOLDER (LEFT)
114	*4-923-503-01	PLATE, INDICATION, RAY CATCHER
902	*A-4655-060-A	MOUNTED PCB, DISPLAY
910	*1-624-421-11	PC BOARD, VOL
911	*1-624-422-11	PC BOARD, MOTOR
912	*1-624-423-11	PC BOARD, TIMER
913	*1-624-424-11	PC BOARD, JACK

4. MECHANISM SECTION (CDM9-6)

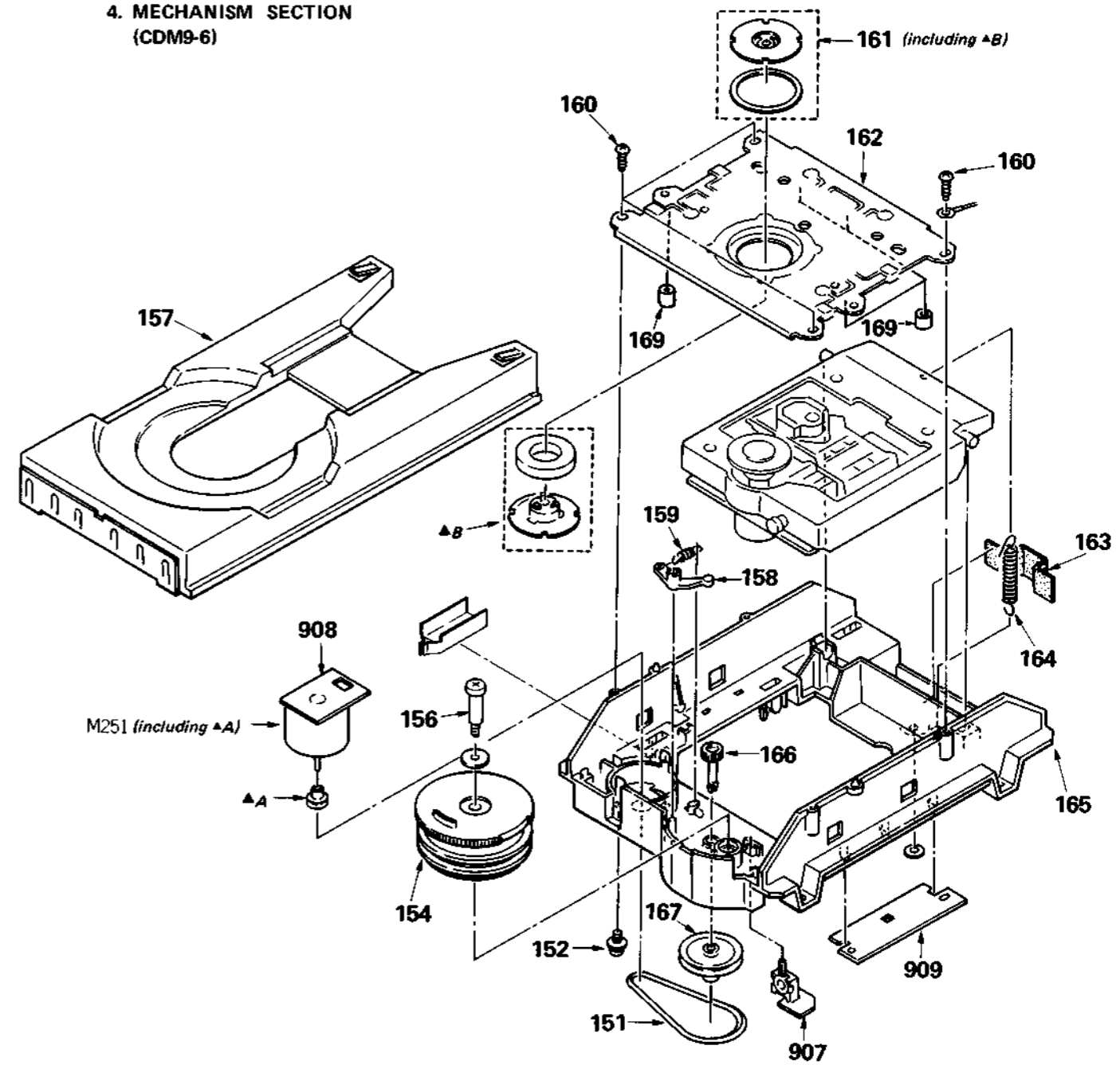

Ref.No	Part No.	Description
151	4-917-522-02	BELT
152	7-628-254-10	+PSW, 2.6X6
154	4-922-511-01	GEAR (LOADING)
156	4-923-597-11	SCREW, STEP
157	*4-922-515-01	TABLE, DISK
158	4-917-519-01	LEVER, SET
159	4-917-514-01	SPRING, TENSION
160	7-685-646-79	SCREW +BTP 3X8 TYPE2 N-S
161	A-4665-024-A	MAGNET ASSY
162	*4-922-510-01	REINFORCEMENT

Ref.No	Part No.	Description
163	*4-923-553-01	CUSHION, VIBRATION PROOF
164	4-922-506-01	SPRING, TENSION
165	*4-922-516-01	CHASSIS (MD)
166	4-922-508-01	GEAR (DRIVING)
167	4-922-512-01	PULLEY
169	*4-922-529-01	DAMPER
907	1-624-323-11	PC BOARD, LOADING SW
908	1-624-324-11	PC BOARD, LOADING MOTOR
909	1-624-326-11	PC BOARD, TRANSLATION
M251	A-4608-346-A	MOTOR ASSY, L

SECTION 5
ELECTRICAL PARTS LIST

5. OPTICAL PICK-UP BLOCK
(BU-6)

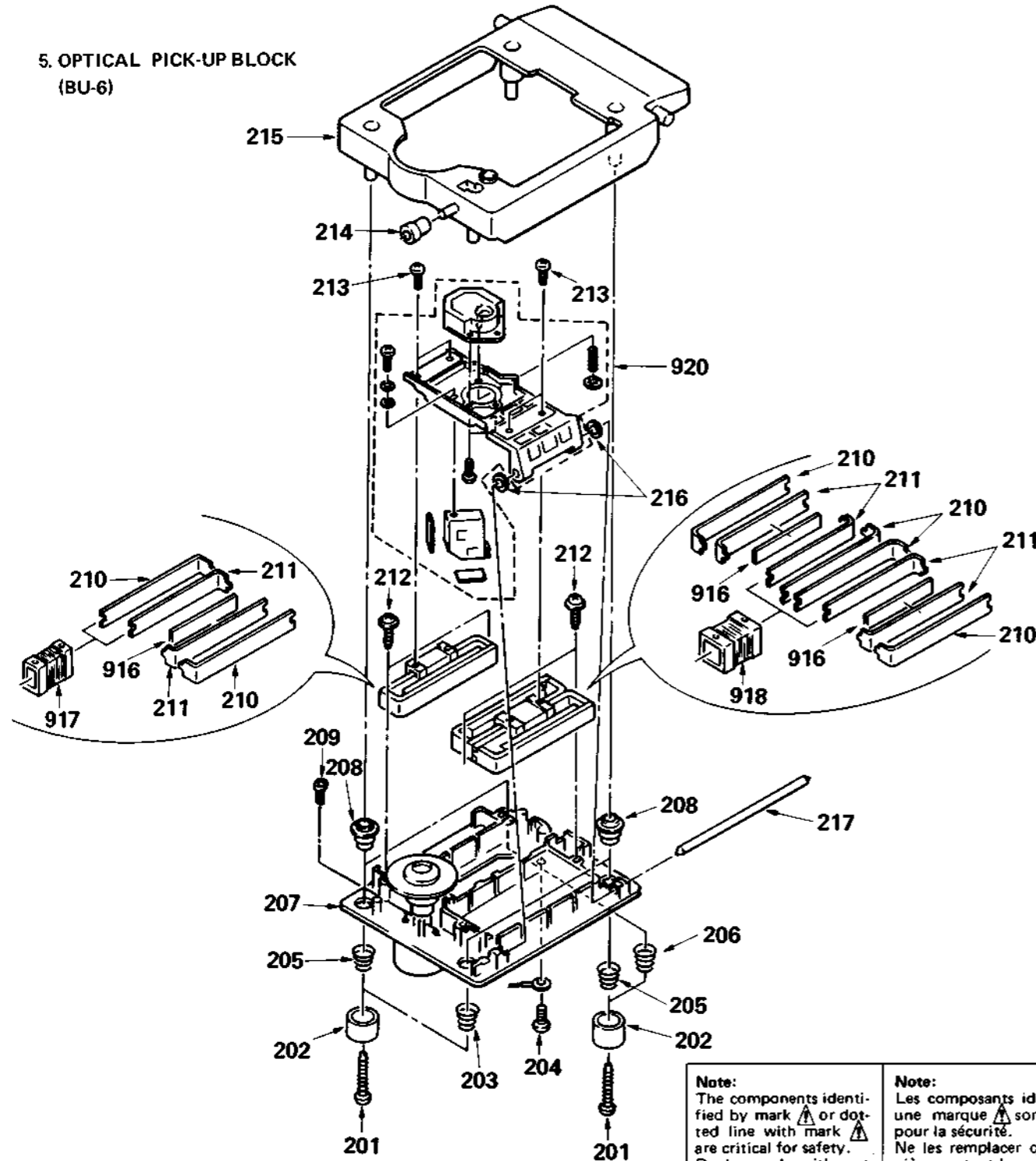

Note:
The components identified by mark Δ or dotted line with mark Δ are critical for safety. Replace only with part number specified.

Note:
Les composants identifiés par une marque Δ sont critiques pour la sécurité. Ne les remplacer que par une pièce portant le numéro spécifié.

Ref.No	Part No.	Description
201	7-686-135-19	SCREW +BTP 2.6X10 TYPE2 N-S
202	4-917-508-01	HOLDER, SP
203	4-917-573-01	SPRING (E)
204	7-621-770-67	SCREW +BVTT 2.6X6 (S)
205	4-917-572-01	SPRING (B)
206	4-917-571-01	SPRING (A)
207	X-4917-525-1	MOTOR ASSY
208	*4-917-584-11	INSULATOR
209	7-621-772-00	+B 2X3
210	*4-917-581-01	YOKE (B)
211	*4-917-580-01	YOKE (A)

Ref.No	Part No.	Description
212	*4-917-583-01	SCREW, YOKE RETAINER
213	3-318-203-61	SCREW, PRECISION, +PTB 1.7X4
214	4-917-515-01	ROLLER
215	*4-922-513-01	BRACKET (BU-6)
216	*4-917-582-01	CUSHION SLIDE
217	*4-917-579-01	GUIDE SHAFT
916	*1-452-411-11	LINEAR MAGNET
917	1-422-302-11	COIL, (DETECT)
918	1-422-301-11	COIL, (DRIVE)
920	Δ 8-848-064-01	OPTICAL PICK-UP BLOCK (KSS-151A)

NOTE:

- Due to standardization, replacements in the parts list may be different from the parts specified in the diagrams or the components used on the set.
- Items marked "*" are not stocked since they are seldom required for routine service. Some delay should be anticipated when ordering these items.
- If there are two or more same circuits in a set such as a stereophonic machine, only typical circuit parts may be indicated and capacitors and resistors in other same circuits may be omitted.

CAPACITORS:
MF: μ F, PF: μ F.

RESISTORS
• All resistors are in ohms.
• F: nonflammable

COILS
• MMH: mH, UH: μ H

SEMICONDUCTORS
In each case, U: μ , for example:
UA...: μ A..., UPA...: μ PA...,
UPC...: μ PC, UPD...: μ PD...

The components identified by mark Δ or dotted line with mark Δ are critical for safety. Replace only with part number specified.

Les composants identifiés par une marque Δ sont critiques pour la sécurité. Ne les remplacer que par une pièce portant le numéro spécifié.

Ref.No	Part No.	Description
901	*A-4651-177-A (E, UK)...	MOUNTED PCB, MAIN
901	*A-4651-198-A (US, Canadian, AEP)...	MOUNTED PCB, MAIN
902	*A-4655-060-A	MOUNTED PCB, DISPLAY
903	1-464-878-11	TRANSMITTER UNIT, RAY
904	*1-535-122-00	TERMINAL
905	*1-535-139-00	BASE POST 19MM (10MM PITCH) 2P
906	*1-535-688-11	TERMINAL
907	*1-624-323-11	PC BOARD, LOADING SW
908	*1-624-324-11	PC BOARD, LOADING MOTOR
909	*1-624-326-11	PC BOARD, TRANSLATION
910	*1-624-421-11	PC BOARD, VOL
911	*1-624-422-11	PC BOARD, MOTOR
912	*1-624-423-11	PC BOARD, TIMER
913	*1-624-424-11	PC BOARD, JACK
914	*1-624-469-11	PC BOARD, POWER
915	*1-624-470-11	PC BOARD, D/O
920	Δ 8-848-064-01	OPTICAL PICK-UP BLOCK (KSS-151A)
921	Δ 1-555-795-00 (AEP)...	CORD, POWER
921	Δ 1-556-035-00 (UK)...	CORD, POWER
921	Δ 1-557-577-11 (US, Canadian)...	CORD, POWER
921	Δ 1-558-795-00 (E)...	CORD, POWER

CAPACITOR

C	Ref.No	Part No.	Description	Value	Tolerance	Voltage
C102	1-124-443-00	ELECT	100MF	20%	6.3V	
C103	1-162-199-31	CERAMIC	10PF	5%	50V	
C104	1-162-199-31	CERAMIC	10PF	5%	50V	
C105	1-162-198-31	CERAMIC	8.2PF	10%	50V	
C106	1-124-908-11	ELECT	22MF	20%	25V	
C107	1-130-477-00	MYLAR	0.0033MF	5%	50V	
C108	1-136-159-00	FILM	0.033MF	5%	50V	
C109	1-162-851-11	CERAMIC	0.1MF	20%	16V	
C110	1-124-908-11	ELECT	22MF	20%	25V	
C111	1-136-159-00	FILM	0.033MF	5%	50V	
C112	1-136-153-00	FILM	0.01MF	5%	50V	
C113	1-124-908-11	ELECT	22MF	20%	25V	
C114	1-162-851-11	CERAMIC	0.1MF	20%	16V	
C115	1-161-375-00	CERAMIC	0.0022MF	30%	16V	
C116	1-161-377-00	CERAMIC	0.0047MF	30%	16V	
C117	1-124-902-00	ELECT	0.47MF	20%	50V	
C200	1-161-379-00	CERAMIC	0.01MF	20%	16V	
C201	1-124-478-11	ELECT	100MF	20%	25V	
C202	1-124-478-11	ELECT	100MF	20%	25V	
C203	1-162-851-11	CERAMIC	0.1MF	20%	16V	
C204	1-162-851-11	CERAMIC	0.1MF	20%	16V	
C205	1-162-294-31	CERAMIC	0.001MF	10%	50V	
C206	1-162-294-31	CERAMIC	0.001MF	10%	50V	
C207	1-162-851-11	CERAMIC	0.1MF	20%	16V	
C208	1-136-155-00	FILM	0.015MF	5%	50V	
C209	1-136-161-00	FILM	0.047MF	5%	50V	
C210	1-162-851-11	CERAMIC	0.1MF	20%	16V	
C211	1-162-851-11	CERAMIC	0.1MF	20%	16V	
C212	1-124-478-11	ELECT	100MF	20%	25V	
C213	1-124-478-11	ELECT	100MF	20%	25V	

C	Ref.No	Part No.	Description	Value	Tolerance	Voltage
C214	1-124-908-11	ELECT	22MF	20%	25V	
C215	1-124-908-11	ELECT	22MF	20%	25V	
C216	1-123-382-00	ELECT	3.3MF	20%	50V	
C217	1-136-165-00	FILM	0.1MF	5%	50V	
C218	1-123-382-00	ELECT	3.3MF	20%	50V	
C219	1-136-159-00	FILM	0.033MF	5%	50V	
C220	1-136-165-00	FILM	0.1MF	5%	50V	
C221	1-130-479-00	MYLAR	0.0047MF	5%	50V	
C222	1-124-499-11	ELECT	1MF	20%	50V	
C223	1-124-927-11	ELECT	4.7MF	20%	50V	
C224	1-124-908-11	ELECT	22MF	20%	25V	
C225	1-162-294-31	CERAMIC	0.001MF	10%	50V	
C226	1-162-282-31	CERAMIC	100PF	10%	50V	
C227	1-124-908-11	ELECT	22MF	20%	25V	
C229	1-162-851-11	CERAMIC	0.1MF	20%	16V	
C231	1-124-908-11	ELECT	22MF	20%	25V	
C251	1-136-157-00	FILM	0.022MF	5%	50V	
C252	1-136-157-00	FILM	0.022MF	5%	50V	
C301	1-162-851-11	CERAMIC	0.1MF	20%	16V	
C302	1-124-908-11	ELECT	22MF	20%	25V	
C303	1-161-379-00	CERAMIC	0.01MF	20%	16V	
C304	1-124-902-00	ELECT	0.47MF	20%	50V	
C305	1-136-159-00	FILM	0.033MF	5%	50V	
C306	1-124-478-11	ELECT	100MF	20%	25V	
C307	1-136-173-00	FILM	0.47MF	5%	50V	
C308	1-162-851-11	CERAMIC	0.1MF	20%	16V	
C321	1-162-179-11	CERAMIC	0.1MF	20%	50V	
C353	1-124-908-11	ELECT	22MF	20%	25V	
C354	1-124-908-11	ELECT	22MF	20%	25V	
C355	1-162-179-11	CERAMIC	0.1MF	20%	50V	
C356	1-162-294-31	CERAMIC	0.001MF	10%	50V	
C380	1-123-343-00	ELECT	33MF	20%	25V	
C382	1-162-219-31	CERAMIC	68PF	5%	50V	
C383	1-162-179-11	CERAMIC	0.1MF	20%	50V	
C384	1-162-179-11	CERAMIC	0.1MF	20%	50V	
C386	1-162-179-11	CERAMIC	0.1MF	20%	50V	
C387	1-162-282-31	CERAMIC	100PF	10%	50V	
C390A	1-124-443-00	ELECT	100MF	20%	10V	
C390B	1-162-179-11	CERAMIC	0.1MF	20%	50V	
C391	1-124-443-00	ELECT	100MF	20%	10V	
C400	1-136-165-00	FILM	0.1MF	5%	50V	
C401	1-136-165-00	FILM	0.1MF	5%	50V	
C402	1-136-165-00	FILM	0.1MF	5%	50V	
C403	1-136-165-00	FILM	0.1MF	5%	50V	
C404	1-136-165-00	FILM	0.1MF	5%	50V	
C405	1-136-165-00	FILM	0.1MF	5%	50V	
C406	1-136-165-00	FILM	0.1MF	5%	50V	
C407	1-136-232-11	FILM	0.0043MF	3%	100V	
C408	1-130-977-11	FILM	0.036MF	3%	100V	
C409	1-130-955-00	FILM	0.01MF	3%	100V	
C410	1-136-232-11	FILM	0.0043MF	3%	100V	
C411	1-136-227-11	FILM	0.0011MF	3%	100V	

Ref.No	Part No.	Description			
R501	1-249-542-11	CARBON	390	5%	1/4W
R502	1-246-545-00	CARBON	1M	5%	1/4W
R503	1-249-425-11	CARBON	4.7K	5%	1/4W
R504	1-247-715-11	CARBON	1.5K	1%	1/4W
R505	1-247-715-11	CARBON	1.5K	1%	1/4W
R506	1-246-533-00	CARBON	330K	5%	1/4W
R507	1-247-700-11	CARBON	100	5%	1/4W
R508	1-247-700-11	CARBON	100	5%	1/4W
R509	1-247-700-11	CARBON	100	5%	1/4W
R521	1-249-441-11	CARBON	100K	5%	1/4W
R522	1-249-408-11	CARBON	180	5%	1/4W
R540	1-249-405-11	CARBON	100	5%	1/4W
R541	1-249-417-11	CARBON	1K	5%	1/4W
R542	1-249-417-11	CARBON	1K	5%	1/4W
R550A	1-249-429-11	CARBON	10K	5%	1/4W
R550B	1-249-409-11	CARBON	220	5%	1/4W
R551	1-247-903-00	CARBON	1M	5%	1/4W
R552	1-249-405-11	CARBON	100	5%	1/4W
R553A	1-249-405-11	CARBON	100	5%	1/4W
R553B	1-249-405-11	CARBON	100	5%	1/4W
R554	1-249-435-11	CARBON	33K	5%	1/4W
R555	1-249-417-11	CARBON	1K	5%	1/4W
R556	1-249-417-11	CARBON	1K	5%	1/4W
R557	1-249-405-11	CARBON	100	5%	1/4W
R558	1-249-417-11	CARBON	1K	5%	1/4W
R801	1-249-422-11	CARBON	2.7K	5%	1/4W
R802	1-249-422-11	CARBON	2.7K	5%	1/4W
R803	1-249-422-11	CARBON	2.7K	5%	1/4W
R804	1-249-422-11	CARBON	2.7K	5%	1/4W
R805	1-249-422-11	CARBON	2.7K	5%	1/4W
R806	1-249-422-11	CARBON	2.7K	5%	1/4W
R807	1-249-422-11	CARBON	2.7K	5%	1/4W
R808	1-249-422-11	CARBON	2.7K	5%	1/4W
R809	1-249-424-11	CARBON	3.9K	5%	1/4W
R810	1-249-424-11	CARBON	3.9K	5%	1/4W
R811	1-249-424-11	CARBON	3.9K	5%	1/4W
R812	1-249-424-11	CARBON	3.9K	5%	1/4W
R813	1-249-424-11	CARBON	3.9K	5%	1/4W
R814	1-249-424-11	CARBON	3.9K	5%	1/4W
R815	1-249-424-11	CARBON	3.9K	5%	1/4W
R816	1-249-424-11	CARBON	3.9K	5%	1/4W
R817	1-249-427-11	CARBON	6.8K	5%	1/4W
R818	1-249-427-11	CARBON	6.8K	5%	1/4W
R819	1-249-427-11	CARBON	6.8K	5%	1/4W
R820	1-249-427-11	CARBON	6.8K	5%	1/4W
R821	1-249-427-11	CARBON	6.8K	5%	1/4W
R822	1-249-427-11	CARBON	6.8K	5%	1/4W
R823	1-249-427-11	CARBON	6.8K	5%	1/4W
R824	1-249-427-11	CARBON	6.8K	5%	1/4W
R825	1-249-432-11	CARBON	18K	5%	1/4W
R826	1-249-432-11	CARBON	18K	5%	1/4W
R827	1-249-432-11	CARBON	18K	5%	1/4W
R828	1-249-432-11	CARBON	18K	5%	1/4W
R829	1-249-432-11	CARBON	18K	5%	1/4W
R830	1-249-432-11	CARBON	18K	5%	1/4W
R831	1-249-432-11	CARBON	18K	5%	1/4W
R832	1-249-432-11	CARBON	18K	5%	1/4W
R833	1-249-429-11	CARBON	10K	5%	1/4W
R834	1-249-429-11	CARBON	10K	5%	1/4W
R835	1-249-429-11	CARBON	10K	5%	1/4W
R836	1-249-429-11	CARBON	10K	5%	1/4W
R837	1-249-429-11	CARBON	10K	5%	1/4W
R838	1-249-429-11	CARBON	10K	5%	1/4W
R839	1-249-441-11	CARBON	100K	5%	1/4W
R840	1-249-429-11	CARBON	10K	5%	1/4W

Ref.No	Part No.	Description			
R842	1-249-429-11	CARBON	10K	5%	1/4W
R843	1-249-429-11	CARBON	10K	5%	1/4W
R844	1-249-429-11	CARBON	10K	5%	1/4W
R845	1-249-429-11	CARBON	10K	5%	1/4W
R846	1-249-429-11	CARBON	10K	5%	1/4W
R847	1-249-429-11	CARBON	10K	5%	1/4W
R848	1-249-429-11	CARBON	10K	5%	1/4W
R900	1-249-520-11	CARBON	47	5%	1/4W
R901	1-249-429-11	CARBON	10K	5%	1/4W
R902	1-247-887-00	CARBON	220K	5%	1/4W
R903	1-249-405-11	CARBON	100	5%	1/4W
R920	1-247-704-11	CARBON	220	5%	1/4W
R921	△ 1-212-867-91	FUSIBLE	27	5%	1/4W F
R930	1-247-704-11	CARBON	220	5%	1/4W
R940	△ 1-212-849-00	FUSIBLE	4.7	5%	1/4W F
R941	1-249-425-11	CARBON	4.7K	5%	1/4W
R942	1-249-433-11	CARBON	22K	5%	1/4W
R944	1-249-437-11	CARBON	47K	5%	1/4W
R945	1-247-891-00	CARBON	330K	5%	1/4W
RV101	1-228-995-00	RES, ADJ, METAL GLAZE 22K (E-F BALANCE)			
RV102	1-237-194-11	RES, ADJ, CARBON 20K (TRACKING GAIN)			
RV103	1-237-194-11	RES, ADJ, CARBON 20K (FOCUS GAIN)			
RV104	1-228-993-00	RES, ADJ, METAL GLAZE 4.7K (FOCUS BIAS)			
RV201	1-228-990-00	RES, ADJ, METAL GLAZE 1K (RF PLL FREQUENCY)			
RV450	1-237-917-41	RES, VAR, CARBON 10K/10K (LINE OUT, PHONE LEVEL)			
RY500	1-515-614-11	RELAY			
S251	1-571-300-11	SWITCH, ROTARY			
S380	1-571-083-11	SWITCH, SLIDE (OUT PUT SELECTOR)			
S801	1-554-303-21	SWITCH, KEY BOARD (1)			
S802	1-554-303-21	SWITCH, KEY BOARD (2)			
S803	1-554-303-21	SWITCH, KEY BOARD (3)			
S804	1-554-303-21	SWITCH, KEY BOARD (4)			
S805	1-554-303-21	SWITCH, KEY BOARD (5)			
S806	1-554-303-21	SWITCH, KEY BOARD (6)			
S807	1-554-303-21	SWITCH, KEY BOARD (7)			
S808	1-554-303-21	SWITCH, KEY BOARD (8)			
S809	1-554-303-21	SWITCH, KEY BOARD (9)			
S810	1-554-303-21	SWITCH, KEY BOARD (10)			
S811	1-554-303-21	SWITCH, KEY BOARD (11)			
S812	1-554-303-21	SWITCH, KEY BOARD (12)			
S813	1-554-303-21	SWITCH, KEY BOARD (13)			
S814	1-554-303-21	SWITCH, KEY BOARD (14)			
S815	1-554-303-21	SWITCH, KEY BOARD (15)			
S816	1-554-303-21	SWITCH, KEY BOARD (16)			
S817	1-554-303-21	SWITCH, KEY BOARD (17)			
S818	1-554-303-21	SWITCH, KEY BOARD (18)			
S819	1-554-303-21	SWITCH, KEY BOARD (19)			
S820	1-554-303-21	SWITCH, KEY BOARD (20)			
S821	1-554-596-21	SWITCH, KEY BOARD (▶▶)			
S822	1-554-596-21	SWITCH, KEY BOARD (ERASE)			
S823	1-554-596-21	SWITCH, KEY BOARD (CONTINUE/SINGLE)			
S824	1-554-596-21	SWITCH, KEY BOARD (SHUFFLE)			
S825	1-554-596-21	SWITCH, KEY BOARD (PROGRAM)			
S826	1-554-596-21	SWITCH, KEY BOARD (>20)			
S827	1-554-596-21	SWITCH, KEY BOARD (CHECK)			
S828	1-554-596-21	SWITCH, KEY BOARD (CLEAR)			
S829	1-554-596-21	SWITCH, KEY BOARD (FILE)			
S830	1-554-596-21	SWITCH, KEY BOARD (INDEX MODE)			
S831	1-554-596-21	SWITCH, KEY BOARD (INDEX →)			
S832	1-554-596-21	SWITCH, KEY BOARD (•)			
S833	1-554-596-21	SWITCH, KEY BOARD (AMS ◀◀)			
S834	1-554-596-21	SWITCH, KEY BOARD (AMS ▶▶)			
S835	1-554-596-21	SWITCH, KEY BOARD (◀◀)			

Note:
The components identified by mark △ or dotted line with mark △ are critical for safety. Replace only with part number specified.

Note:
Les composants identifiés par une marque △ sont critiques pour la sécurité. Ne les remplacer que par une pièce portant le numéro spécifié.

Ref.No	Part No.	Description
S836	1-554-596-21	SWITCH, KEY BOARD (DISPLAY)
S837	1-554-596-21	SWITCH, KEY BOARD (▲)
S838	1-554-596-21	SWITCH, KEY BOARD (AUTO POUSE)
S839	1-554-596-21	SWITCH, KEY BOARD (REPEAT)
S840	1-554-596-21	SWITCH, KEY BOARD (INDEX ←)
S841	1-554-596-21	SWITCH, KEY BOARD (▶)
S842	1-554-596-21	SWITCH, KEY BOARD (II)
S843	1-554-481-00	SWITCH, SLIDE (TIMER)
S990	▲.1-554-920-11	SWITCH, PUSH (AC POWER) (1 KEY)
T380	1-421-946-11	TRANSFORMER, PULSE
T901	▲.1-449-285-11	(US, Canadian).... TRANSFORMER, POWER
T901	▲.1-449-286-11	(AEP, UK).... TRANSFORMER, POWER
T901	▲.1-449-287-11	(E).... TRANSFORMER, POWER
T991	▲.1-421-960-11	TRANSFORMER, LINE FILTER
▲THP901	.1-808-065-11	(AEP, UK, E).... THERMISTOR, POSITIVE
▲THP911	.1-808-065-11	(AEP, UK, E).... THERMISTOR, POSITIVE
VS901	▲.1-526-576-51	(E).... SELECTOR, POWER VOLTAGE
X301	1-567-686-11	OSCILLATOR, CERAMIC (4MHz)
X520	1-567-926-11	VIBRATOR, CRYSTAL (16.9344MHz)
X801	1-567-192-11	OSCILLATOR, CERAMIC (4MHz)

Ref.No	Part No.	Description
ACCESSORY & PACKING MATERIAL		
	1-463-909-11	COMMANDER, REMOTE (RM-D650)
▲.1-526-565-12	(E)....	AC PLUG ADAPTOR
1-551-315-00		CORD, CONNECTION
3-703-390-01	(US)....	INSTRUCTION
*3-704-346-01	(EXCEPT E)....	SHEET (STANDARD), PROTECTION
3-769-608-11	(Canadian, AEP, E)....	MANUAL, INSTRUCTION
3-769-608-21	(US)....	MANUAL, INSTRUCTION
3-769-608-41	(AEP)....	MANUAL INSTRUCTION
*3-795-629-11	(AEP)....	INSTRUCTION
*4-912-947-01		KEY, LOCK
4-922-528-01		LID, BATTERY CASE, COMMANDER
4-923-539-11	(Canadian, US, E)....	INDIVIDUAL CARTON
4-923-539-21	(AEP, UK)....	INDIVIDUAL CARTON
4-923-540-01		CUSHION

<p>Note: The components identified by mark ▲ or dotted line with mark ▲ are critical for safety. Replace only with part number specified.</p>	<p>Note: Les composants identifiés par une marque ▲ sont critiques pour la sécurité. Ne les remplacer que par une pièce portant le numéro spécifié.</p>
--	--