

CDP-791/X111ES

SERVICE MANUAL

*US Model
Canadian Model*

CDP-X111ES

*AEP Model
UK Model*

CDP-791

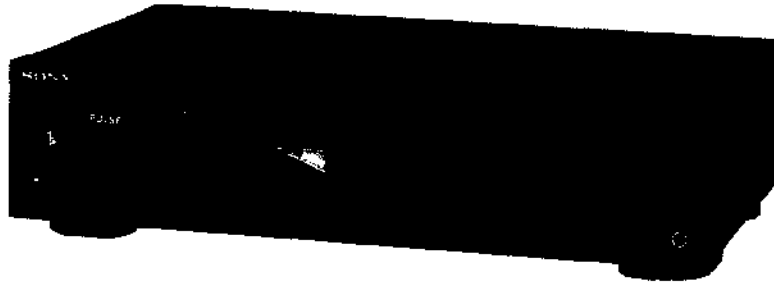

Photo: CDP-791

SPECIFICATIONS

Compact disc player

Frequency response	2 Hz - 20 kHz \pm 0.5 dB
Signal-to-noise ratio	More than 108 dB
Dynamic range	More than 98 dB
Harmonic distortion	Less than 0.0027%
Channel separation	More than 100 dB

Outputs

LINE OUT (FIXED) (phono jacks)	Output level 2 V (at 50 kilohms) Load impedance over 10 kilohms
LINE OUT (VARIABLE) (phono jacks)	Output level max. 2 V (at 50 kilohms) Load impedance over 50 kilohms
DIGITAL OUT (OPTICAL) (optical output connector)	Wave length 660 nm Output level -18 dBm
PHONES (stereo phone jack)	Output level max. 10 mW Load impedance 32 ohms

General

Power requirements	US, Canadian Model: 120 V AC, 60 Hz AEP Model: 220 V - 230 V AC, 50/60 Hz UK Model: 240 V AC, 50 Hz
--------------------	---

Model Name Using Similar Mechanism	CDP-291/391
CD Mechanism Type	CDM14-5BD1
Optical Pick-Up Block Type	BU-5BD1

Power consumption	12 W
Dimensions (approx., including projections)	430 \times 110 \times 280 mm (w/h/d) (17 \times 4 $\frac{1}{4}$ \times 11 $\frac{1}{16}$ inches)
Weight (approx.)	4.0 kg (8 lbs 14 oz)

Supplied accessories

Audio cord	1 (2 phono plugs - 2 phono plugs)
Remote commander	1
R6 (AA) batteries	2

Remote commander RM-D791

Remote control system	Infrared control
Power requirements	3 V DC with two R6 (size AA) batteries
Dimensions	Approx. 62 \times 20 \times 175 mm (w/h/d) (2 $\frac{1}{2}$ \times $\frac{13}{16}$ \times 7 inches)
Weight	Approx. 130 g (4.6 oz) Including batteries

Design and specifications subject to change without notice.



COMPACT DISC PLAYER
SONY®

SAFETY CHECK-OUT

After correcting the original service problem, perform the following safety check before releasing the set to the customer:

Check the antenna terminals, metal trim, "metallized" knobs, screws, and all other exposed metal parts for AC leakage. Check leakage as described below.

LEAKAGE TEST

The AC leakage from any exposed metal part to earth ground and from all exposed metal parts to any exposed metal part having a return to chassis, must not exceed 0.5 mA (500 microampers). Leakage current can be measured by any one of three methods.

1. A commercial leakage tester, such as the Simpson 229 or RCA WT-540A. Follow the manufacturers' instructions to use these instruments.
2. A battery-operated AC milliammeter. The Data Precision 245 digital multimeter is suitable for this job.
3. Measuring the voltage drop across a resistor by means of a VOM or battery-operated AC voltmeter. The "limit" indication is 0.75 V, so analog meters must have an accurate low-voltage scale. The Simpson 250 and Sanwa SH-63Trd are examples of a passive VOM that is suitable. Nearly all battery operated digital multimeters that have a 2 V AC range are suitable. (See Fig. A)

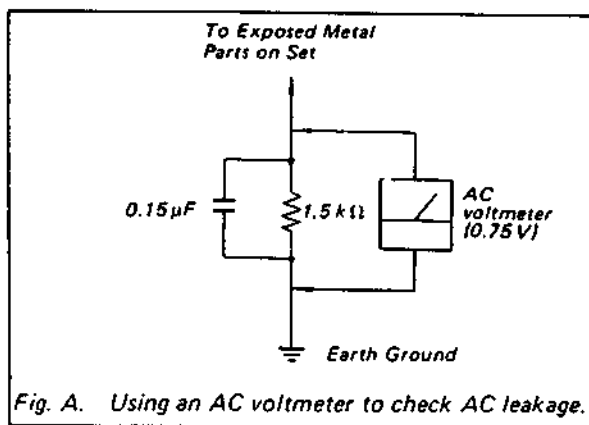

SAFETY-RELATED COMPONENT WARNING!!

COMPONENTS IDENTIFIED BY MARK OR DOTTED LINE WITH MARK ON THE SCHEMATIC DIAGRAMS AND IN THE PARTS LIST ARE CRITICAL TO SAFE OPERATION. REPLACE THESE COMPONENTS WITH SONY PARTS WHOSE PART NUMBERS APPEAR AS SHOWN IN THIS MANUAL OR IN SUPPLEMENTS PUBLISHED BY SONY.

MODEL IDENTIFICATION

—Model Number Label—

CDP-791
CDP-X111ES

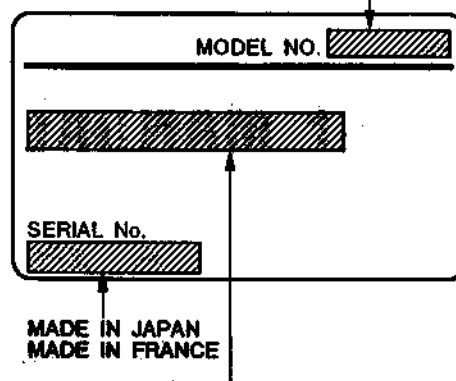

US Model: AC120V 60Hz 12W
 Canadian Model: AC: 120V 60 Hz 12W
 AEP Model: AC220 - 230V, 50/60Hz
 UK Model: AC240V-50/ 60Hz

TABLE OF CONTENTS

<u>Section</u>	<u>Title</u>	<u>Page</u>
Specifications	1
Safety Check-out	2
Model Identification	2
1. GENERAL		
	Notes on Handling the Optical Pick-up	
	Block or Base Unit	3
	Notes on Laser Diode Emission Check	3
	Location of Controls	3
	Adjusting Operating Voltage	3
2. DISASSEMBLY	4
3. ELECTRICAL BLOCK CHECKING		
	S Curve Check	5
	RF Level Check	5
	E-F Balance Check	5
	RF PLL Free-run Frequency Check	6
	Focus/Tracking Gain	6
4. DIAGRAMS		
	IC101(CXA1372Q)PIN DESCRIPTIONS	7
4-1.	Block Diagram	8
4-2.	Printed Wiring Boards	12
4-3.	Schematic Diagram	15
5. EXPLODED VIEWS	21
6. ELECTRICAL PARTS LIST	24

ATTENTION AU COMPOSANT AYANT RAPPORT À LA SÉCURITÉ!

LES COMPOSANTS IDENTIFIÉS PAR UNE MARQUE SUR LES DIAGRAMMES SCHÉMATIQUES ET LA LISTE DES PIÈCES SONT CRITIQUES POUR LA SÉCURITÉ DE FONCTIONNEMENT. NE REMPLACER CES COMPOSANTS QUE PAR DES PIÈCES SONY DONT LES NUMÉROS SONT DONNÉS DANS CE MANUEL OU DANS LES SUPPLÉMENTS PUBLIÉS PAR SONY.

NOTES ON HANDLING THE OPTICAL PICK-UP BLOCK OR BASE UNIT

The laser diode in the optical pick-up block may suffer electrostatic breakdown because of the potential difference generated by the charged electrostatic load, etc. on clothing and the human body. During repair, pay attention to electrostatic breakdown and also use the procedure in the printed matter which is included in the repair parts. The flexible board is easily damaged and should be handled with care.

NOTES ON LASER DIODE EMISSION CHECK

The laser beam on this model is concentrated so as to be focused on the disc reflective surface by the objective lens in the optical pick-up block. Therefore, when checking the laser diode emission, observe from more than 30cm away from the objective lens.

For UK Model and AEP Model

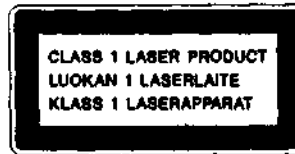

This Compact Disc player is classified as a CLASS 1 LASER product. The CLASS 1 LASER PRODUCT label is located on the rear exterior.

Adjusting Operating Voltage

For the customers of the model equipped with the voltage selector

Check that the voltage selector is set to the local power line voltage. If not, set the selector to the correct position before connecting AC power cord to a wall outlet.

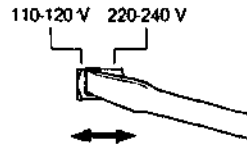

This section is extracted from instruction manual.

SECTION 1 GENERAL

Location of Controls

Front Panel

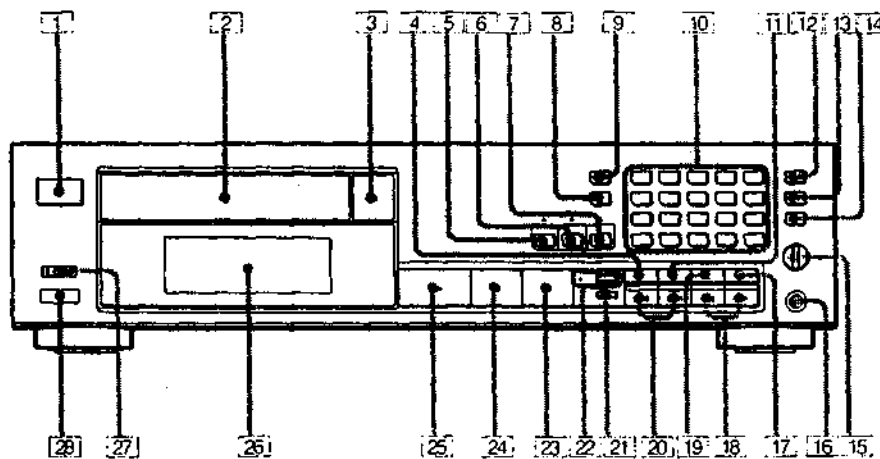

- 1 POWER switch ①
- 2 Disc tray ②
- 3 ▲ OPEN/CLOSE button ③
- 4 PEAK SEARCH button ④
- 5 CONTINUE button and indicator ⑤, ⑥, ④, ⑤, ⑥
- 6 SHUFFLE button and indicator ⑦
- 7 PROGRAM button and indicator ⑧, ④
- 8 TIME SET button ⑧, ⑩
- 9 EDIT/TIME FADE button ⑨, ⑩
- 10 Numeric buttons ⑩
- 11 REPEAT button ⑪
- 12 >20 (over 20) button ⑫
- 13 CHECK (program check) button ⑬, ⑤
- 14 CLEAR (program clear) button ⑭, ④, ⑤
- 15 LINE OUT/PHONE LEVEL control ⑮
- 16 PHONES jack ⑮
- 17 MUSIC SCAN button ⑯
- 18 ◀▶ (manual search) buttons ⑰, ⑱
- 19 FADER button ⑲, ⑱
- 20 ◀▶▶▶ (AMS*) buttons ⑲, ⑱
- 21 TIME button ⑲
- 22 A. SPACE (auto space)/A. CUE(auto cue) button and auto cue indicator ⑳, ⑲
- 23 ■ (stop) button ㉑
- 24 || (pause) button ㉒
- 25 ▶ (play) button ㉓
- 26 Display window ㉔
- 27 TIMER switch ㉕
- 28 Remote sensor ㉖

Remote commander

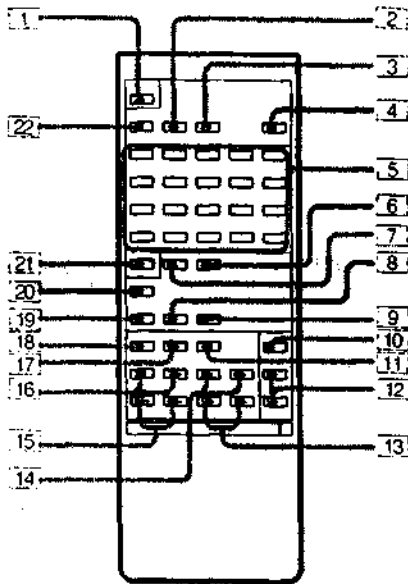

- 1 ▲ OPEN/CLOSE button ①
- 2 SHUFFLE button ⑩
- 3 PROGRAM button ④⑥, ④④
- 4 M.SCAN (music scan) button ④②
- 5 Numeric buttons ②②
- 6 CLEAR (program clear) button ④③, ④②, ⑤①
- 7 CHECK button ④②, ④①
- 8 A → B repeat button ④③
- 9 A.SPACE (auto space)/A.CUE (auto cue) button ④⑤, ④②
- 10 FADER button ④⑤, ④②
- 11 ■ (stop) button ④⑥
- 12 LINE OUT LEVEL + / - (line out/headphone volume) buttons ④⑥
- 13 ◀◀◀ SLOW (low speed manual search) buttons ④④
- 14 ◀◀◀ (manual search) buttons ④④, ④①
- 15 ◀ → INDEX buttons ④④
- 16 ▶▶▶▶ AMS buttons ④②, ④⑤
- 17 || (pause) button ④⑥
- 18 ▶ (play) button ④⑥
- 19 CLEAR/REPEAT (A → B repeat clear/repeat) button ④③
- 20 TIME button ④②
- 21 20 (over 20) button ④②
- 22 CONTINUE button ④③, ④③, ④④, ⑤②, ⑤①

SECTION 2
DISASSEMBLY

BASE UNIT REMOVAL

Note: Follow the disassembly procedure in the numerical order given.

1. Remove CD mechanism from the set and turn over.
2. Turn the cam ① in the Arrow ② direction by the ③ driver.
3. Take out disc table ④.
4. Remove bracket yoke ⑤.
5. Remove BU-SBD1 ⑥ in the Arrow ⑦ direction.

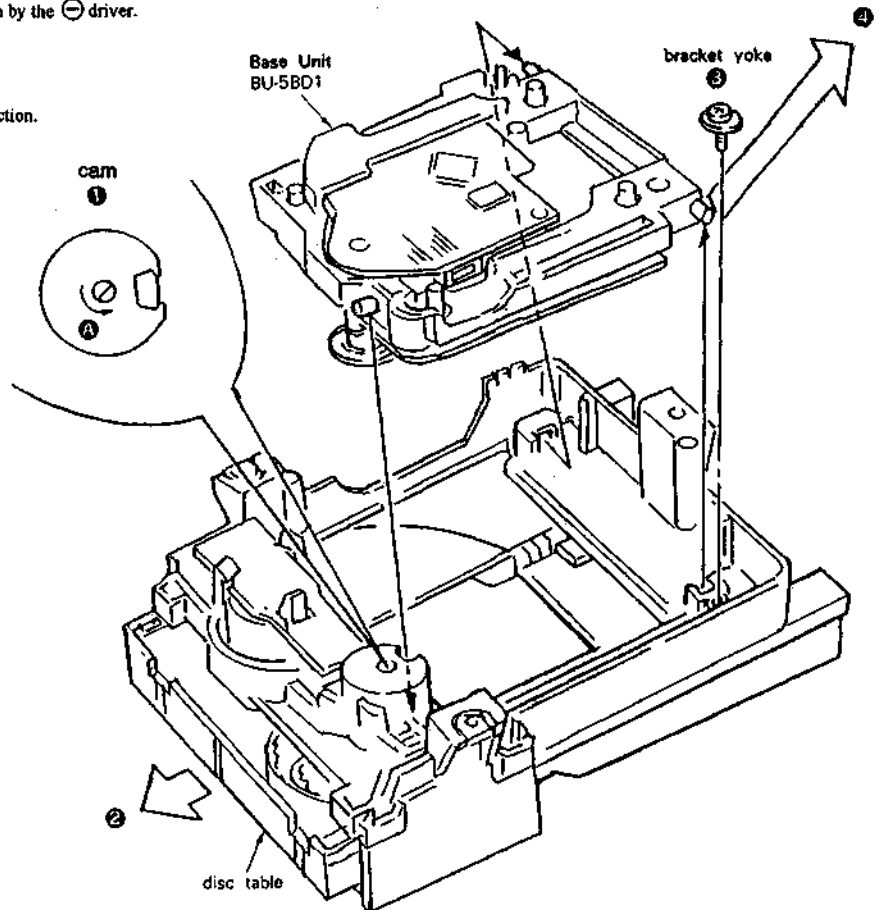

SECTION 3 ELECTRICAL BLOCK CHECKING

Note :

1. CD Block basically constructed to operate without adjustment. Therefore, check each item in order given.
2. Use YEDS-18 disc (3-702-101-01) unless otherwise indicated.
3. Use the oscilloscope with more than 10MΩ impedance.
4. Clean an object lens by an applicator with neutral detergent when the signal level is low than specified value with the following checks.

S Curve Check

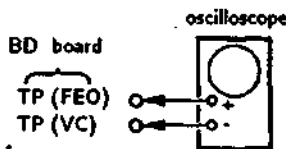

Procedure :

1. Connect oscilloscope to test point TP (FEO) on BD board.
2. Connect between test point TP (FES) and TP (VC) by lead wire.
3. Turned Power switch on and actuate the focus serch. (actuate the focus serch when disc table is moving in and out.)
4. Check the oscilloscope waveform (S curve) is symmetrical between A and B. And confirm peak to peak level within $3 \pm 1V_{p-p}$.

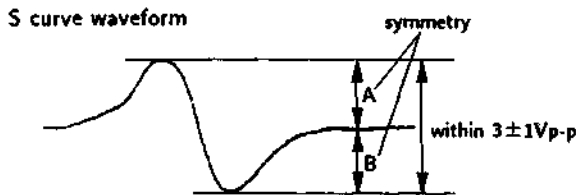

5. After check, remove the lead wire connected in step 2.

Note : • Try to measure several times to make sure that the ratio of A : B or B : A is more than 10 : 7.

• Take sweep time as long as possible and light up the brightness to obtain best waveform.

RF Level Check

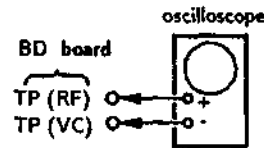

Procedure :

1. Connect oscilloscope to test point TP (RF) on BD board.
2. Turn Power switch on.
3. Put disc (YEDS-18) in and playback.
4. Confirm that oscilloscope waveform is clear and check RF signal level is correct or not.

Note :

Clear RF signal waveform means that the shape "◇" can be clearly distinguished at the center of the waveform.

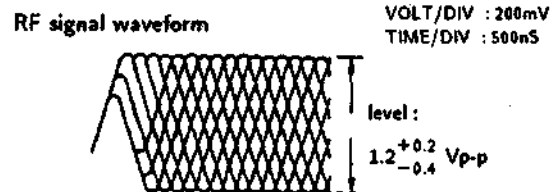

E-F Balance Check

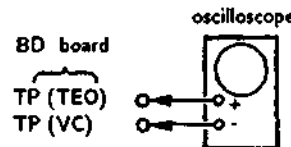

Procedure :

1. Connect test point TP (ADJ) to ground and TP (TES) to TP (VC) with lead wire.
2. Connect oscilloscope to test point TP (TEO) on BD board.
3. Turn Power switch on.
4. Put disc (YEDS-18) in and playback.
5. Confirm that the oscilloscope waveform is symmetrical on the top and bottom in relation to 0V, and check this level.

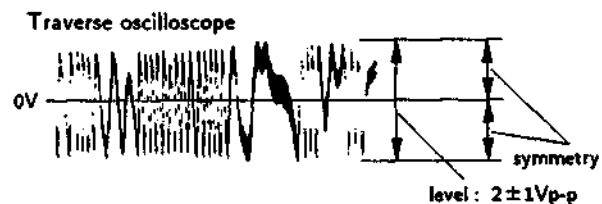

6. Remove the lead wire connected in step 1.

RF PLL Free-run Frequency Check

Procedure :

1. Connect frequency counter to test point (PCK) with lead wire.

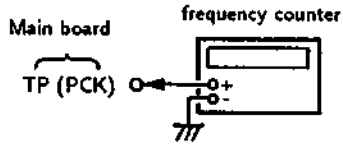

2. Turn Power switch on.
3. Confirm that reading on frequency counter is
4. 3218MHz.

Focus/Tracking Gain

This gain has a margin, so even if it is slightly off. There is no problem.

Therefore, do not perform, this adjustment.

Please note that it should be fixed to mechanical center position when you moved and do not know original position.

**Adjustment Locations :
[BD board]**

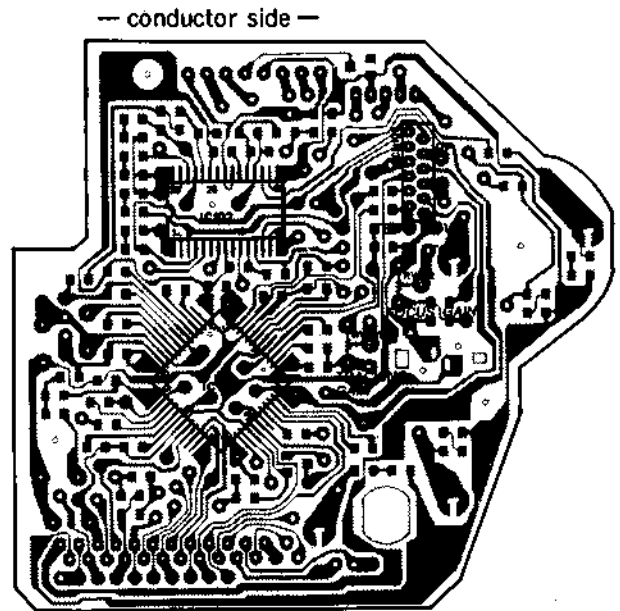

[Main board]

- Component Side -

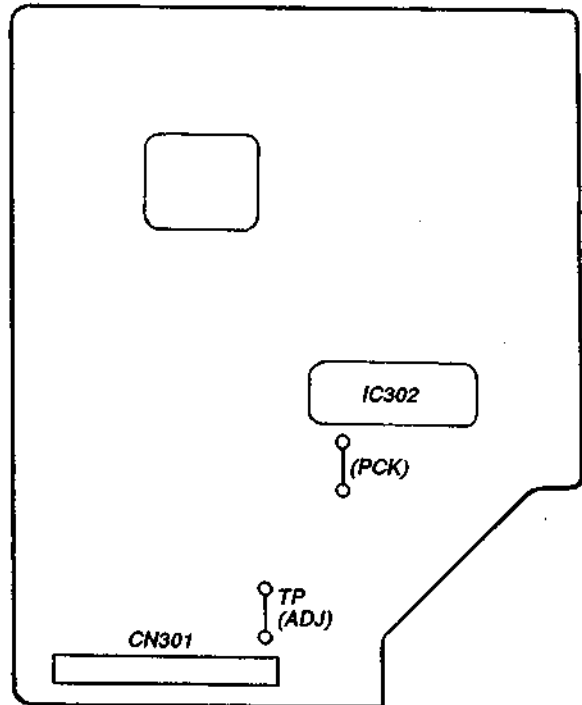

SECTION 4 DIAGRAMS

IC101 (CXA13720) PIN DESCRIPTIONS

PIN NO.	PIN NAME	I/O	FUNCTION
1	VC		2.5 Volts power supply.
2	FGD	I	Focus gain adjusting capacitor connected between ② pin and ③ pin.
3	FS3	I	Focus gain adjusting capacitor connected between ② pin and ③ pin.
4	FLB	I	Focus Servo low frequency boost-up capacitor connected.
5	FEO	O	Focus drive output.
6	FE-	I	Focus error amp inverted input.
7	SRCH	I	Connected capacitor to making the focus serch waveform.
8	TGU	I	Tracking gain adjusting capacitor connected between ⑧ pin and ⑨ pin.
9	TG2	I	Tracking gain adjusting capacitor connected between ⑧ pin and ⑨ pin.
10	AVCC		+5 Volts power supply.
11	TAO	O	Tracking drive output.
12	TA-	I	Tracking amp inverted input.
13	SL+	I	Sled amp non-inverted input.
14	SLO	O	Sled drive output.
15	SL-	I	Sled amp non-inverted input.
16	FSET	I	Phase stabilizer setting resistor connected.
17	ISET	I	Current setting resistor connected.
18	SSTOP	I	Limit switch connection port.
19	AVEE		Ground (0V).
20	DIRC	I	Direct control port. Non-connected.
21	LOCK	I	Sled free-run protection is operate at "L".
22	CLK	I	Serial data transmission clock input form digital signal processor.
23	XLT	I	Latch input from digital signal processor.
24	DATA	I	Serial input from digital signal processor.
25	SENS	O	Outputs internal state corresponding to address.
26	XRST	I	System reset input. Reset at "L".
27	C. OUT	O	Tracking counter output.
28	D GND		Digitel ground. Grounded
29	MIRR	O	Mirror output digital signal processor.
30	DFCT	O	Defect output. Defect at "H".
31	ASY	I	Auto symmetry control input.
32	EFM	O	EFM Comparator output.
33	FOK	O	Focus OK.
34	CC2	I	Defect bottom hold input.
35	CC1	O	Defect bottom hold output.
36	DVCC		+5 Volts power supply.
37	CB	I	Defect bottom hold capacitor connected.
38	CP	I	Mirror hold capacitor connected.
39	RFI	I	RF Signal input (Capacitance coupled).
40	RFO	I	RF Signal input (Direct Coupled).
41	DVEE		Grounded (0V).
42	TZC	I	Tracking Zero-cross comparator input.
43	TE	I	Tracking error amp input.
44	TDFCT	I	Defect correction hold capacitor connected.
45	ATSC	I	Anti-shock input.
46	FZC	I	Focus Zero-cross comparator input.
47	FE	I	Focus error input.
48	DFCT	I	Defect correction hold capacitor connected.

• Circuit Boards Location

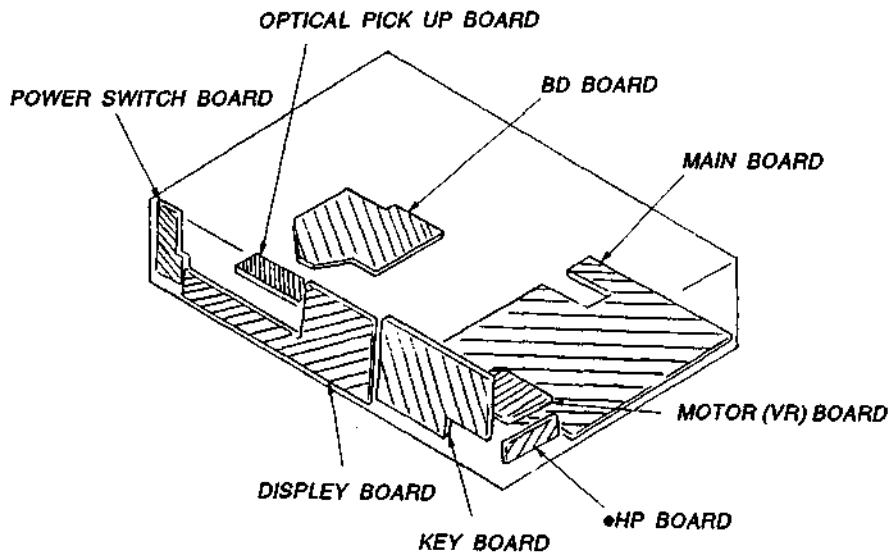

• Semiconductor Location

Ref. No.	Location	Ref. No.	Location
D101	B-22	IC202	G-17
D201	E-19	IC203	G-16
D202	I-19	IC301	H-16
D203	E-18	IC302	G-15
D204	E-18	IC303	G-14
D205	E-17	IC304	H-13
D206	E-17	IC305	E-15
D207	G-19	IC306	D-15
D208	F-17	IC307	C-15
D209	F-16	IC391	B-14
D341	F-15	IC401	C-9
D351	G-13	IC403	B-4
D401	E-2	IC451	H-6
D402	E-2	IC471	I-7
D403	E-3	IC491	H-2
D404	E-3		
D405	E-3	Q101	D-22
D406	B-9	Q201	F-19
D407	B-9	Q202	G-18
D408	B-9	Q203	F-18
D409	B-9	Q204	H-18
D410	B-9	Q205	H-18
D411	B-9	Q206	H-17
D412	B-4	Q207	G-18
D413	B-5	Q208	G-18
D414	B-5	Q209	F-16
D415	B-6	Q341	D-13
D416	B-6	Q342	D-14
D417	D-8	Q343	D-13
D418	D-3	Q344	G-13
D419	F-2	Q371	B-14
D420	F-3	Q372	C-16
D421	F-2	Q373	B-14
D471	J-7	Q374	C-16
		Q375	C-14
IC101	D-21	Q376	B-16
IC102	C-21	Q393	B-14
IC103	B-22	Q419	A-5
IC201	F-19	Q421	B-2

Note:

- ○ — : parts extracted from the component side.
- ■ : parts mounted on the conductor side.

(2) CD MECHANISM SECTION (CDM14-5BD1)

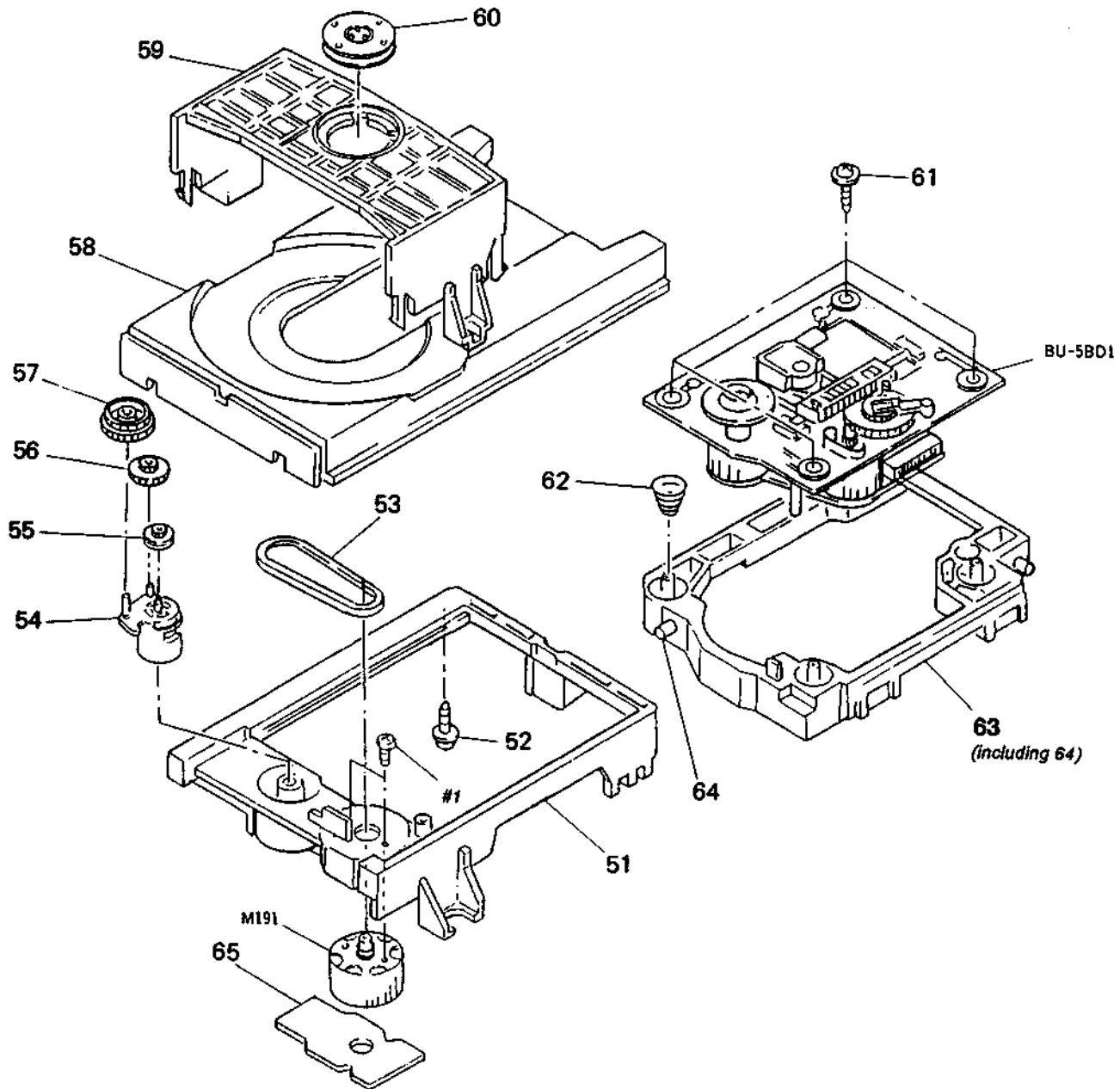

(3) OPTICAL PICK-UP BLOCK (BU-5BD1)

