

# CDP-770

## SERVICE MANUAL

US Model  
Canadian Model  
AEP Model  
UK Model  
E Model



### SPECIFICATIONS

#### Compact disc player

System	Compact disc digital audio system
Laser	Semiconductor laser ( $\lambda = 780 \text{ nm}$ ) Emission duration: continuous
Laser output	Max. $44.6 \mu\text{W}^*$ * This output is the value measured at a distance of about 200 mm from the objective lens surface on the Optical Pick-up Block.
Frequency response	2Hz - 20,000 Hz ( $\pm 0.3 \text{ dB}$ )
Signal-to-noise ratio	More than 102 dB
Dynamic range	More than 95 dB
Harmonic distortion	Less than 0.003% (1kHz)
Channel separation	More than 98 dB (1kHz)

#### Outputs

LINE OUT (Fixed) (phono jacks)	Output level 2 V (at 50 kilohms) Load impedance over 10 kilohms
DIGITAL OUT (OPTICAL) (optical output connector)	Wave length 660 nm Output level - 18 dBm
HEADPHONES (stereo phono jack)	Output level max. 15 mW Load Impedance 32 ohms

#### General

Power requirements	120 V AC, 60Hz
Power consumption	12W
Dimensions (approx.) (w/h/d)	430 $\times$ 95 $\times$ 275 mm (17 $\times$ 3 3/4 $\times$ 10 3/4 inches) including projecting parts and controls
Weight (approx., net)	3.5 kg (7 lbs 11 oz)

Model Name Using Similar Mechanism	CDP-208ESD
CD Transport Mechanism Type	KSS-150A(RP)
Optical Pick-Up Block Type	BU-5C

#### Supplied accessories

Audio signal connecting cord	1 (2 phono plugs - 2 phono plugs)
Remote commander	1
Sony SUM-3 (NS) batteries	2

#### Remote commander

Remote control system	Infrared control
Power requirements	3 V DC with two size AA (R6) batteries
Dimensions	67 $\times$ 20 $\times$ 175 mm (w/h/d) (2 3/4 $\times$ 1 3/16 $\times$ 7 inches)
Weight	135 g (5 oz) including batteries

Design and specifications subject to change without notice.

#### SAFETY-RELATED COMPONENT WARNING!!

COMPONENTS IDENTIFIED BY MARK  $\Delta$  OR DOTTED LINE WITH MARK  $\Delta$  ON THE SCHEMATIC DIAGRAMS AND IN THE PARTS LIST ARE CRITICAL TO SAFE OPERATION. REPLACE THESE COMPONENTS WITH SONY PARTS WHOSE PART NUMBERS APPEAR AS SHOWN IN THIS MANUAL OR IN SUPPLEMENTS PUBLISHED BY SONY.



COMPACT DISC PLAYER  
**SONY**<sup>®</sup>

TABLE OF CONTENTS

<u>Section</u>	<u>Title</u>	<u>Page</u>	<u>Section</u>	<u>Title</u>	<u>Page</u>
<b>SECTION 1 GENERAL</b>			3-4.	Explanation of IC601 (MSC6458-36SS)	15
1-1.	Location of Controls	3	3-4-1.	Pin Description	15
<b>SECTION 2 ELECTRICAL ADJUSTMENTS</b>			3-5.	IC Block Diagrams	17
<b>SECTION 3 DIAGRAMS</b>			<b>SECTION 4 EXPLODED VIEWS</b>		
3-1.	Semiconductor Lead Layouts	7	4-1.	Main Block	18
3-2.	Printed wiring Boards	8	4-2.	Optical Pick-Up Block	20
3-3.	Schematic Diagram	11	<b>SECTION 5 ELECTRICAL PARTS LIST</b>		
			21		

**SAFETY CHECK-OUT**

After correcting the original service problem, perform the following safety check before releasing the set to the customer:

Check the antenna terminals, metal trim, "metallized" knobs, screws, and all other exposed metal parts for AC leakage. Check leakage as described below.

**LEAKAGE TEST**

The AC leakage from any exposed metal part to earth ground and from all exposed metal parts to any exposed metal part having a return to chassis, must not exceed 0.5 mA (500 microampers). Leakage current can be measured by any one of three methods.

1. A commercial leakage tester, such as the Simpson 229 or RCA WT-540A. Follow the manufacturers' instructions to use these instruments.
2. A battery-operated AC milliammeter. The Data Precision 245 digital multimeter is suitable for this job.

3. Measuring the voltage drop across a resistor by means of a VOM or battery-operated AC voltmeter. The "limit" indication is 0.75 V, so analog meters must have an accurate low-voltage scale. The Simpson 250 and Sanwa SH-63Trd are examples of a passive VOM that is suitable. Nearly all battery operated digital multimeters that have a 2V AC range are suitable. (See Fig. A)

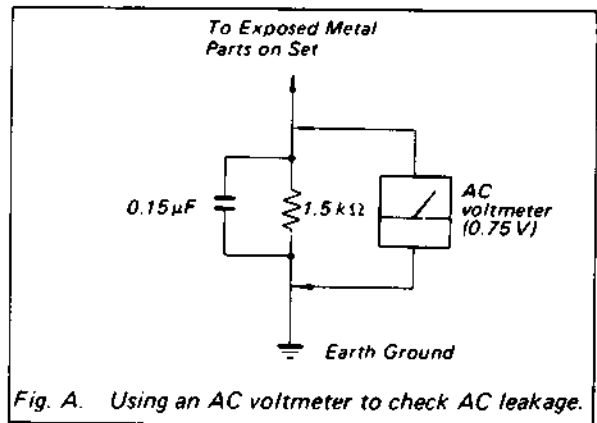

Fig. A. Using an AC voltmeter to check AC leakage.

**SERVICING NOTE**

**NOTES ON HANDLING THE OPTICAL PICK-UP BLOCK OR BASE UNIT**

The laser diode in the optical pick-up block may suffer electrostatic breakdown because of the potential difference generated by the charged electrostatic load, etc. on clothing and the human body. During repair, pay attention to electrostatic breakdown and also use the procedure in the printed matter which is included in the repair parts. The flexible board is easily damaged and should be handled with care.

**CAUTION**

Use of controls or adjustments or performance of procedures other than those specified herein may result in hazardous radiation exposure.

**NOTES ON LASER DIODE EMISSION CHECK**

The laser beam on this model is concentrated so as to be focused on the disc reflective surface by the objective lens in the optical pick-up block. Therefore, when checking the laser diode emission, observe from more than 30 cm away from the objective lens.

## SECTION 1 GENERAL

### 1-1. LOCATION OF CONTROLS

#### Front Panel

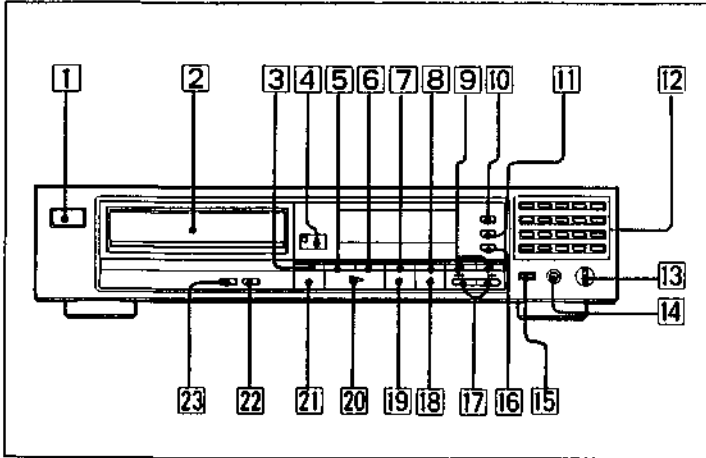

- 1 POWER switch
- 2 Disc compartment
- 3 REPEAT button
- 4 REMOTE sensor
- 5 FADER (FADE IN/FADE OUT) button
- 6 EDIT/TIME FADE button
- 7 CHECK (program check) button
- 8 CLEAR (program clear) button
- 9 ◀▶ (manual search) buttons
- 10 PROGRAM or PGM button
- 11 SHUFFLE button
- 12 Numeric buttons
- 13 HEADPHONE VOL control
- 14 PHONES jack
- 15 > 20 (over 20) button
- 16 CONTINUE/SINGLE button
- 17 ◀▶▶ (AMS\*) buttons
- 18 ■ (stop) button
- 19 || (pause) button
- 20 ▶ (play) button
- 21 ▲ (open/close) button
- 22 AUTO SPACE button
- 23 TIME button

\*AMS is the abbreviation of Automatic Music Sensor.

#### Remote Commander

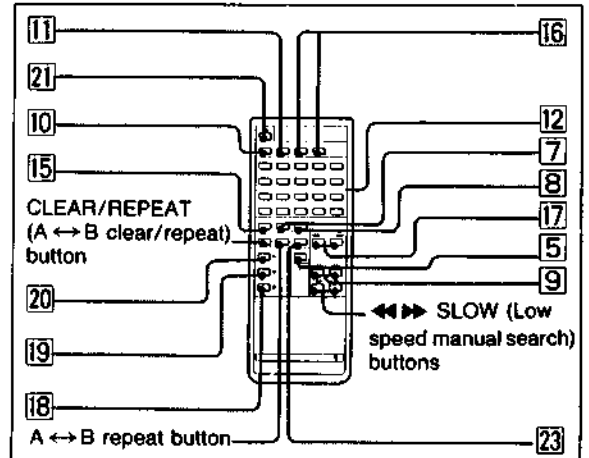

This indicates a function available only on the main unit.



This indicates a function available only on the remote commander.

## SECTION 2 ELECTRICAL ADJUSTMENTS

1. Perform adjustments in the order given.
2. Use YEDS-18 (Part No: 3-702-101-01) disc unless otherwise indicated.
3. Use the oscilloscope with more than 10 MΩ impedance.

### RF PLL Frequency Adjustment/Lock Frequency Check

Procedure :

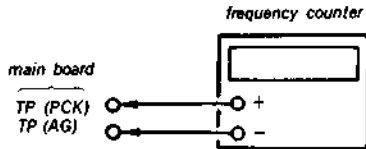

1. Connect test point TP (ASY) to ground with lead wire.
2. Turn POWER switch on.
3. Connect the frequency counter to test point TP (PCK) and TP (AG).
4. Adjust RV201 so that the reading on the frequency counter is  $4.3218\text{MHz} \pm 30\text{kHz}$ .... (RF PLL frequency adjustment).
5. Remove lead wire connecting TP (ASY) to ground.
6. Put disc (YEDS-18) in and press ▷ button.
7. Confirm that the reading on frequency counter is  $4.3218\text{MHz}$ .... (Lock frequency check).

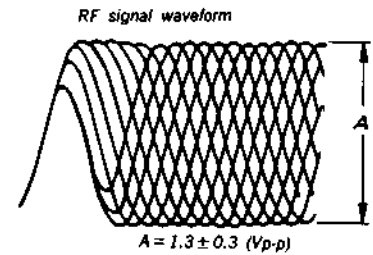

Adjustment Location : main board

### E-F Balance Adjustment

This adjustment should be made when replacing TOP (T-type Optical Pick-up).

Procedure :

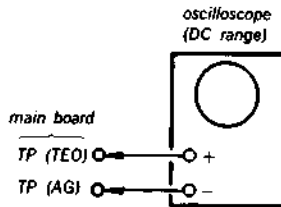

1. Connect test point TP (ADJ) and test point TP (TEI) to ground with lead wire.
2. Connect oscilloscope to test point TP (TEO) and TP (AG).
3. Turn POWER switch on.
4. Put disc (YEDS-18) in and press ▷ button.
5. Adjust RV101 so that the traverse waveform is symmetrical above and below.
6. After adjustment, remove the lead wire connected in step 5.

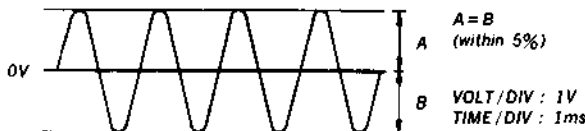

### Focus Bias Adjustment

This adjustment should be made when replacing TOP (T-type Optical Pick-up).

Procedure :

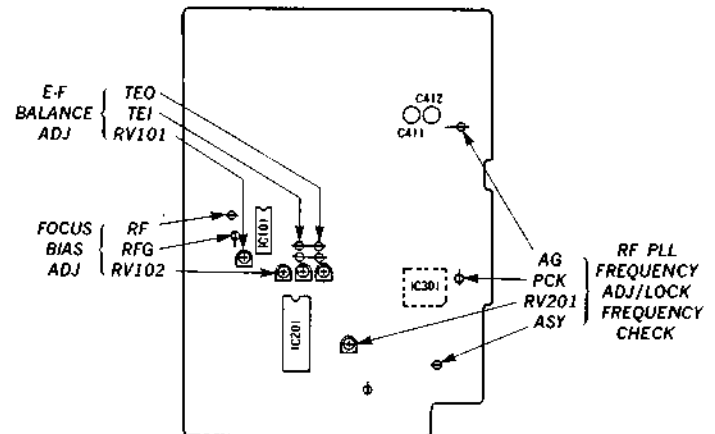
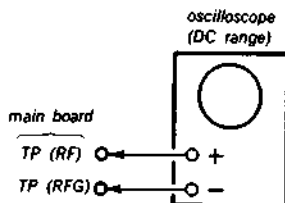

## REFERENCE

### Focus/Tracking Gain Adjustments

A frequency response analyzer is necessary in order to perform this adjustment exactly.

However, this gain has a margin, so even if it is slightly off, there is no problem. Therefore, do not perform this adjustment.

Focus/tracking gain determines the pick-up follow up (vertical and horizontal) relative to mechanical noise and shock when the 2-axis device operate.

However, as these reciprocate, the adjustment is at the point where both are satisfied.

- When gain is raised, the noise when the 2-axis device operates increases.
- When gain is lowered, mechanical shock and skipping occurs more easily.
- When gain adjustment is off, the symptoms below appear.

Symptoms	Gain	Focus	Tracking
• The time until music starts becomes longer for ■ → ▷ or automatic selection. (◀◀, ▷▷ buttons pressed.) (Normally takes about 1 seconds.)		low	low or high
• Music does not start and disc continues to rotate for ■ → ▷ or automatic selection. (◀◀, ▷▷ buttons pressed.)		-	low
• Disc table opens shortly after ■ → ▷ .		low or high	-
• Sound is interrupted during PLAY or time counter display stops progressing.		-	low
• More noise during 2-axis device operation.		high	high

The following is a simple adjustment method.

#### -Primary Adjustment-

**Note:** Since exact adjustment cannot be performed, remember the positions of the controls before performing the adjustment. If the position after the primary adjustment are only a little different, return the controls to the original position.

#### Procedure:

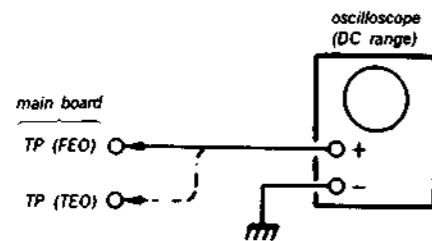

1. Keep the set horizontal.  
(If the set is not horizontal, this adjustment cannot be performed due to the gravity against the 2-axis device.)
2. Insert disc (YEDS-18: Fifth Selection) and press ▷ button.
3. Connect oscilloscope to main board TP (FEO).
4. Adjust RV103 so that the waveform is as shown in the figure below. (focus gain adjustment)
5. Connect oscilloscope to main board TP (TEO).
6. Adjust RV104 so that the waveform is as shown in the figure below. (tracking gain adjustment)

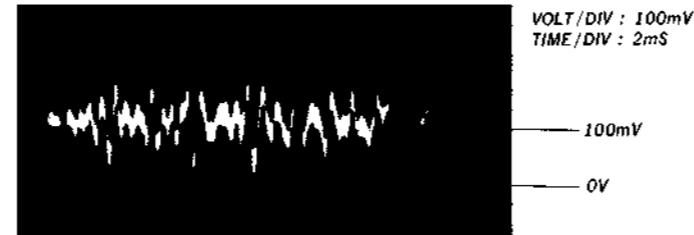

• Incorrect Examples (DC level changes more than on adjusted waveform)

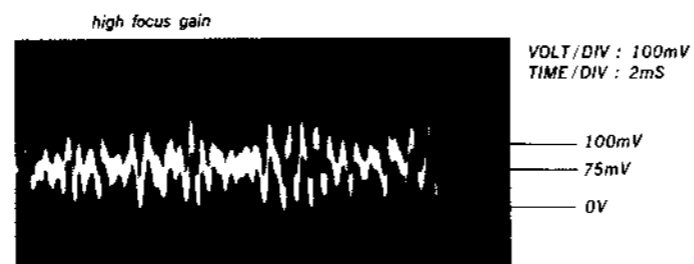
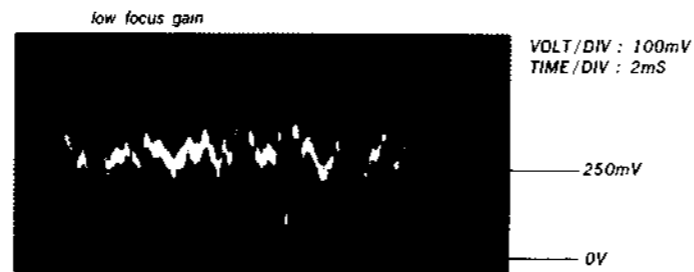

• Incorrect Examples (fundamental wave appears)

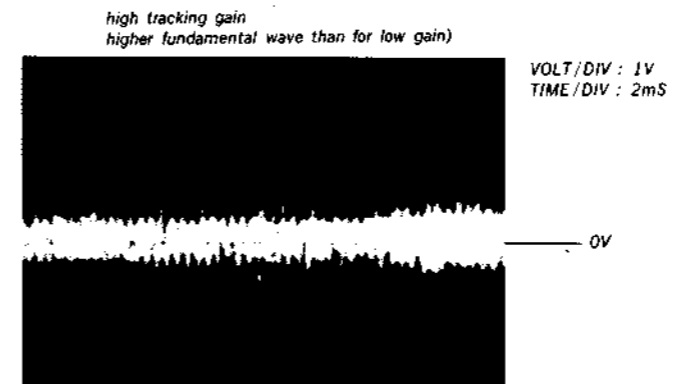

Adjustment Location: main board

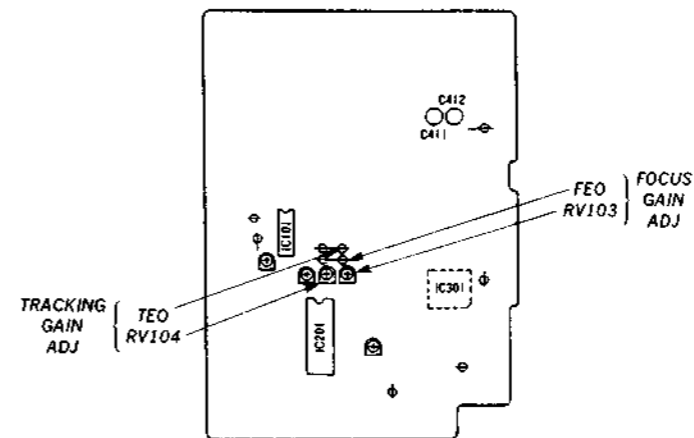

SECTION 3  
DIAGRAMS

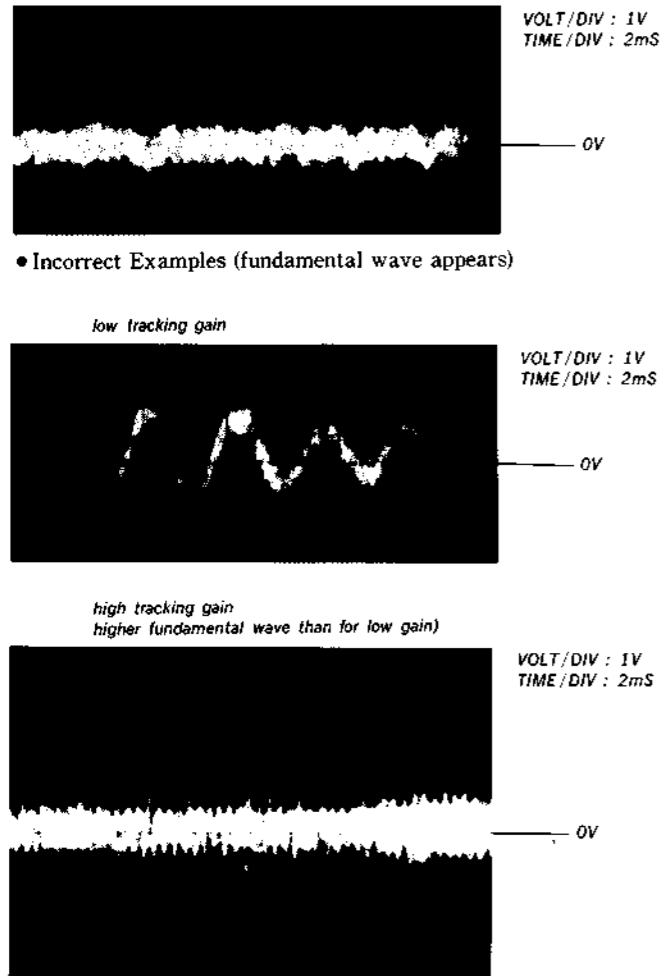

Adjustment Location : main board

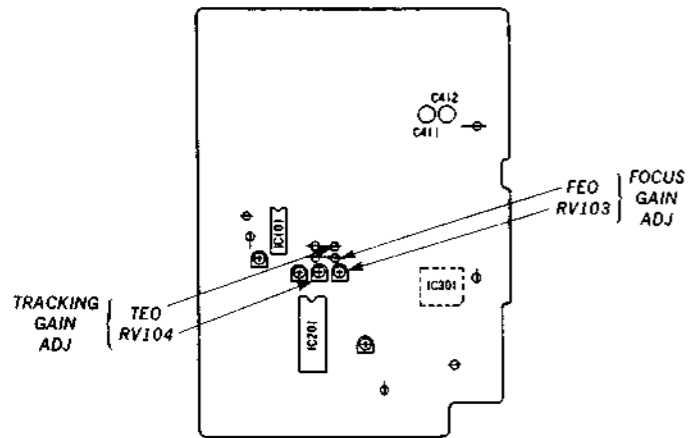

3-1. SEMICONDUCTOR LEAD LAYOUTS

<p><b>CXA1081S</b></p> <p>(Top view)</p>	<p><b>GP1F31T</b></p>	<p><b>M5231TL</b></p>	<p><b>BR4361F</b></p> <p>anode cathode</p>
<p><b>CXA1082BS</b></p> <p>(Top view)</p>	<p><b>GP1U52</b></p>	<p><b>M5294P PCM56P-S</b></p> <p>(Top view)</p>	<p><b>HZS9B2L RD5.1ESB2 1SS132</b></p> <p>cathode anode</p>
<p><b>CXA1291P</b></p>	<p><b>LC9600P-144</b></p>	<p><b>NJM4556S</b></p>	<p><b>US1060M 10E2</b></p> <p>cathode anode</p>
<p><b>CXD1125Q</b></p> <p>MARKING SIDE VIEW</p>	<p><b>MSC6458-36SS</b></p> <p>(Top view)</p>	<p><b>DTA144ES DTC114ES DTC143TS DTC144ES</b></p>	
<p><b>CXD2550P</b></p> <p>(Top view)</p>	<p><b>M5218P M74HC6004P</b></p> <p>(Top view)</p>	<p><b>DTC114EF</b></p>	

• Semiconductor Location

Ref. No.	Location
D001	C-4
D002	C-4
D003	C-4
D004	C-5
D005	D-6
D006	D-5
D401	D-3
D501	C-12
D601	I-18
D602	I-17
D603	I-17
D604	I-17
D605	I-14
D606	I-14
D607	I-14
D608	J-14
IC001	E-4
IC002	D-5
IC101	E-6
IC201	H-5
IC202	H-7
IC203	I-7
IC301	G-3
IC302	F-3
IC303	F-2
IC304	A-2
IC305	E-3
IC401	E-2
IC402	E-2
IC403	C-3
IC501	B-12
IC601	I-16
IC602	I-13
Q001	E-5
Q101	G-6
Q201	I-4
Q202	I-3
Q301	G-4
Q401	B-3
Q402	B-2
Q403	C-4
Q404	I-2
Q407	B-3
Q408	B-2
Q601	I-15
Q602	I-15
Q603	I-15

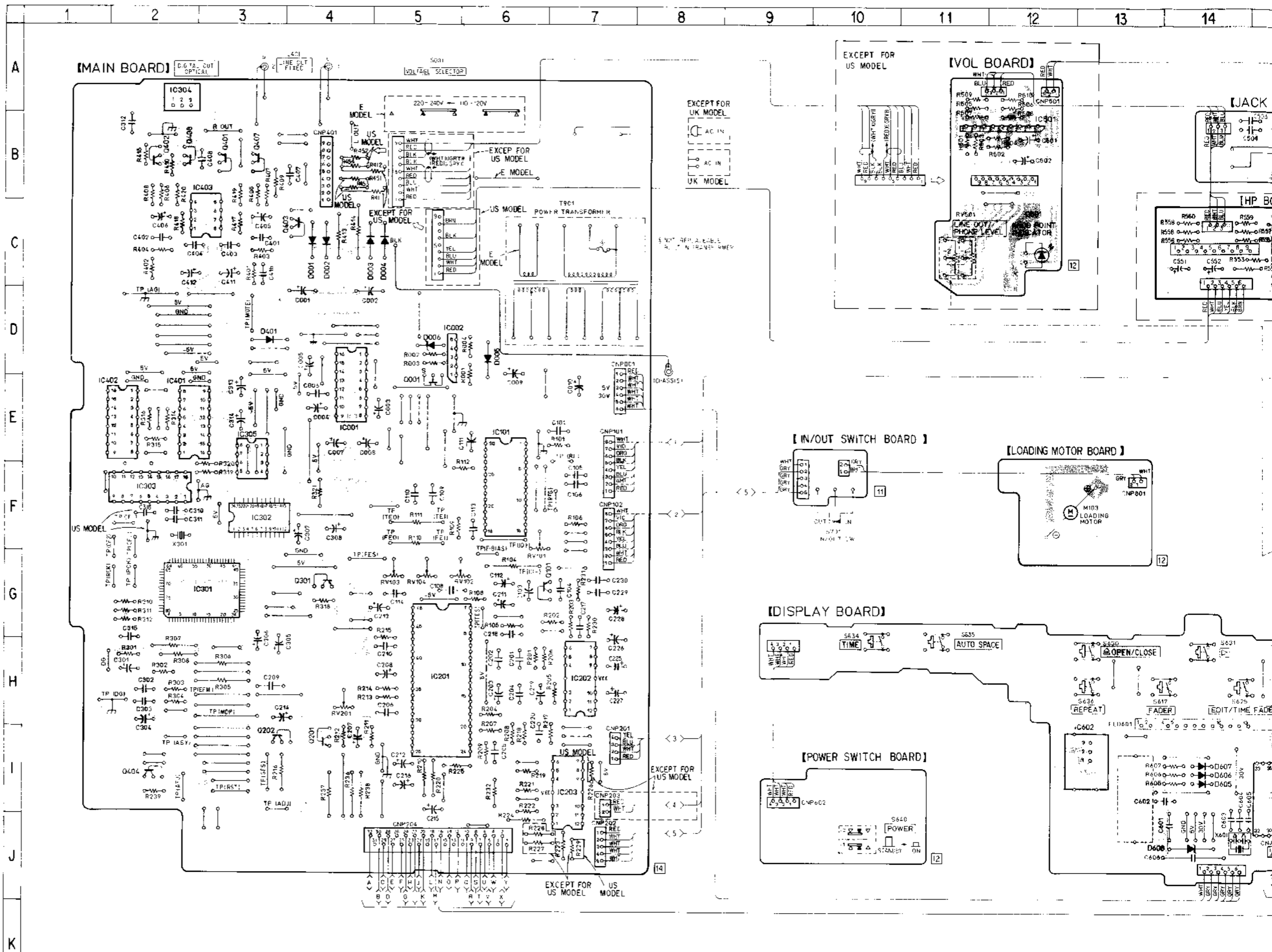





A  
B  
C  
D  
E  
F  
G  
H  
I  
J  
K  
L  
M  
N  
O  
P  
Q

[POWER SWITCH BOARD] [EXCEPT FOR US MODEL] [MOTOR BOARD] [LOADING MOTOR BOARD] [IN/OUT SWITCH BOARD] [SL/SF BOARD]

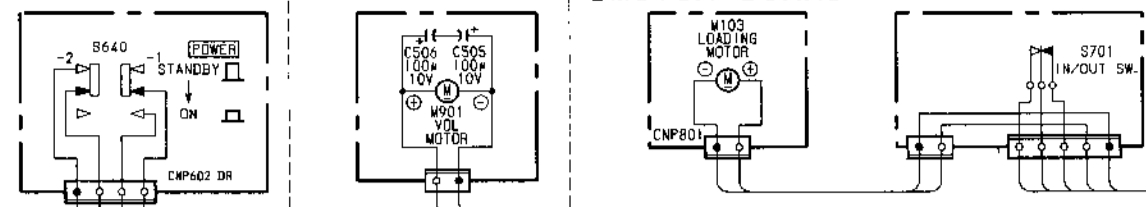

[DISPLAY BOARD]

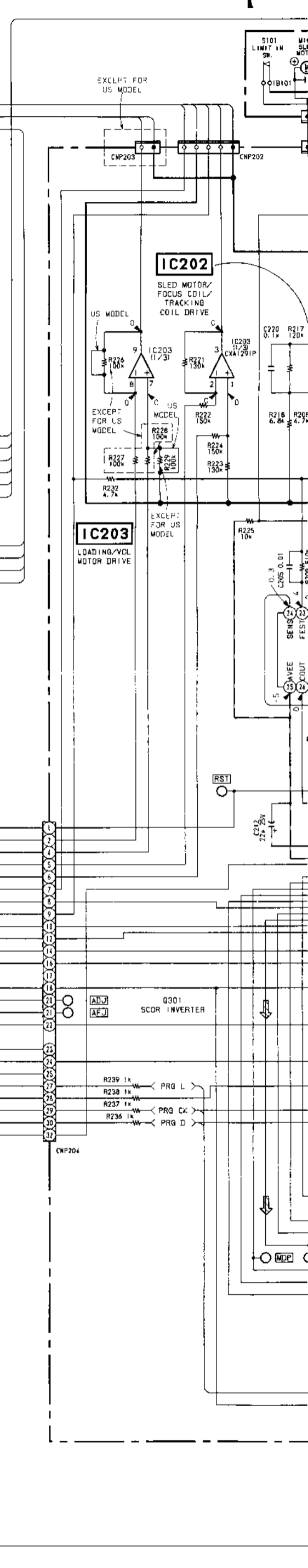
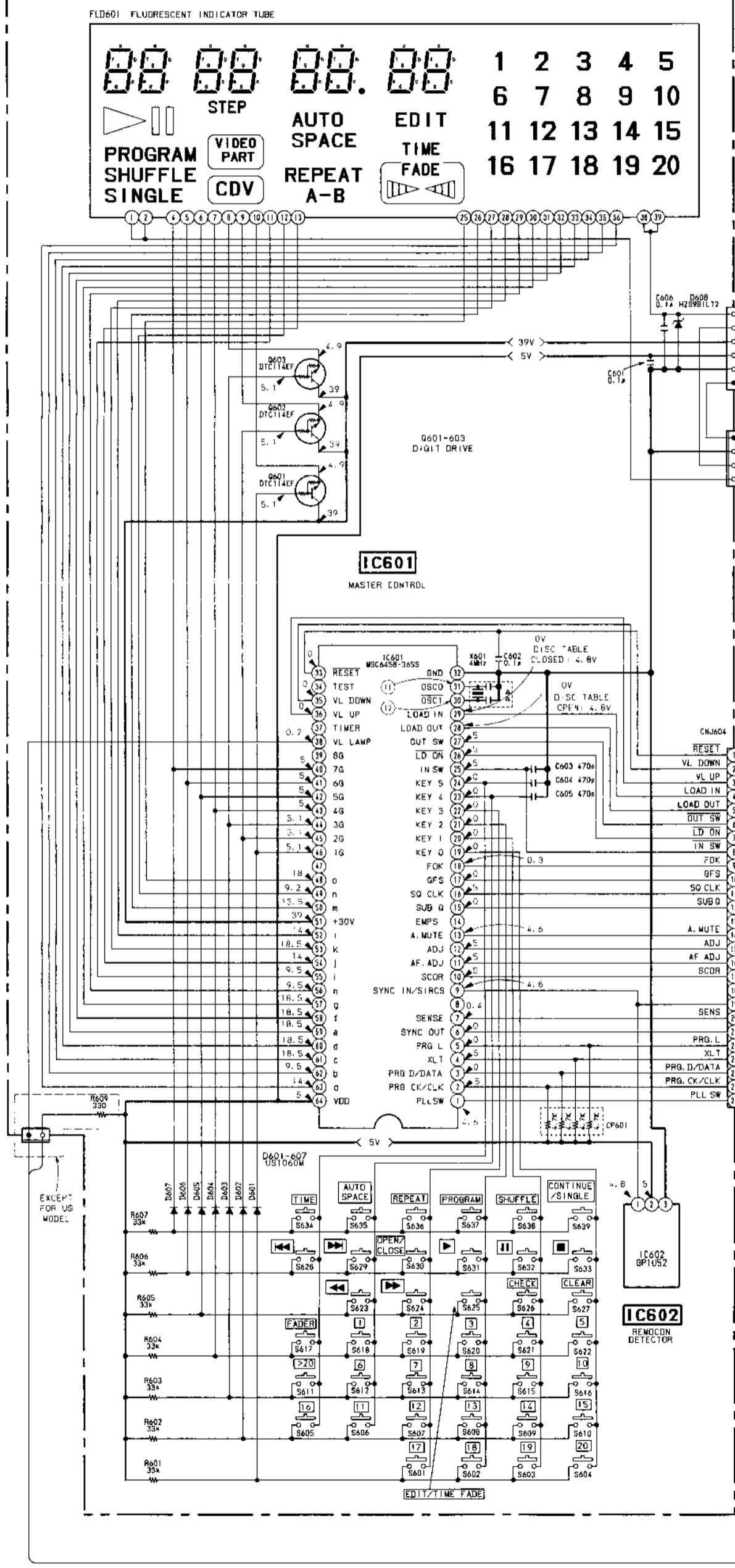

OPTICAL PICK UP BLOCK (KSS-150A (RP))

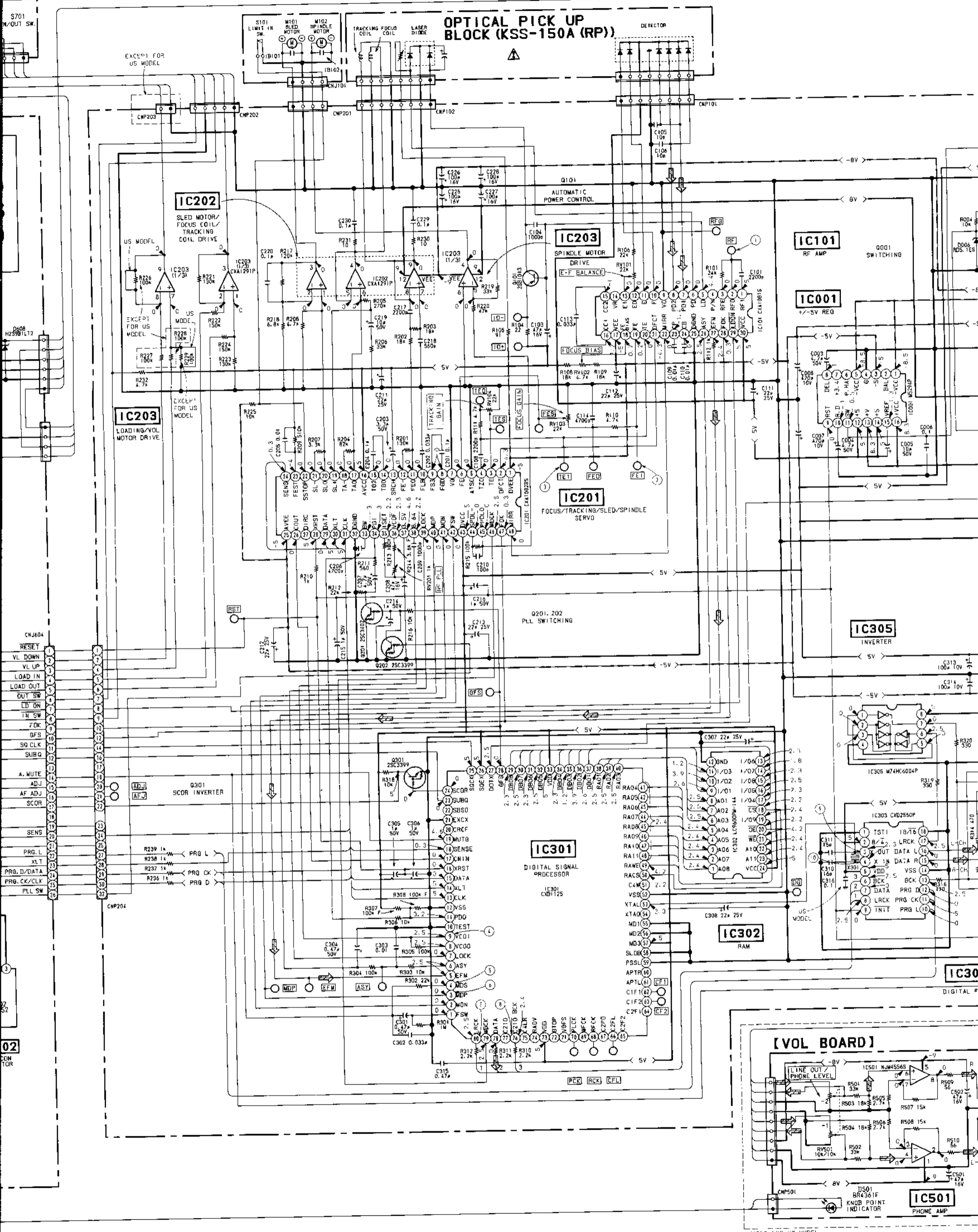

[VOL BOARD]

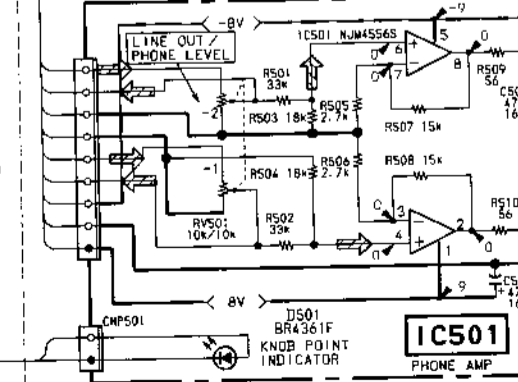

### WIND UP (50A (RP))

### [MAIN BOARD]

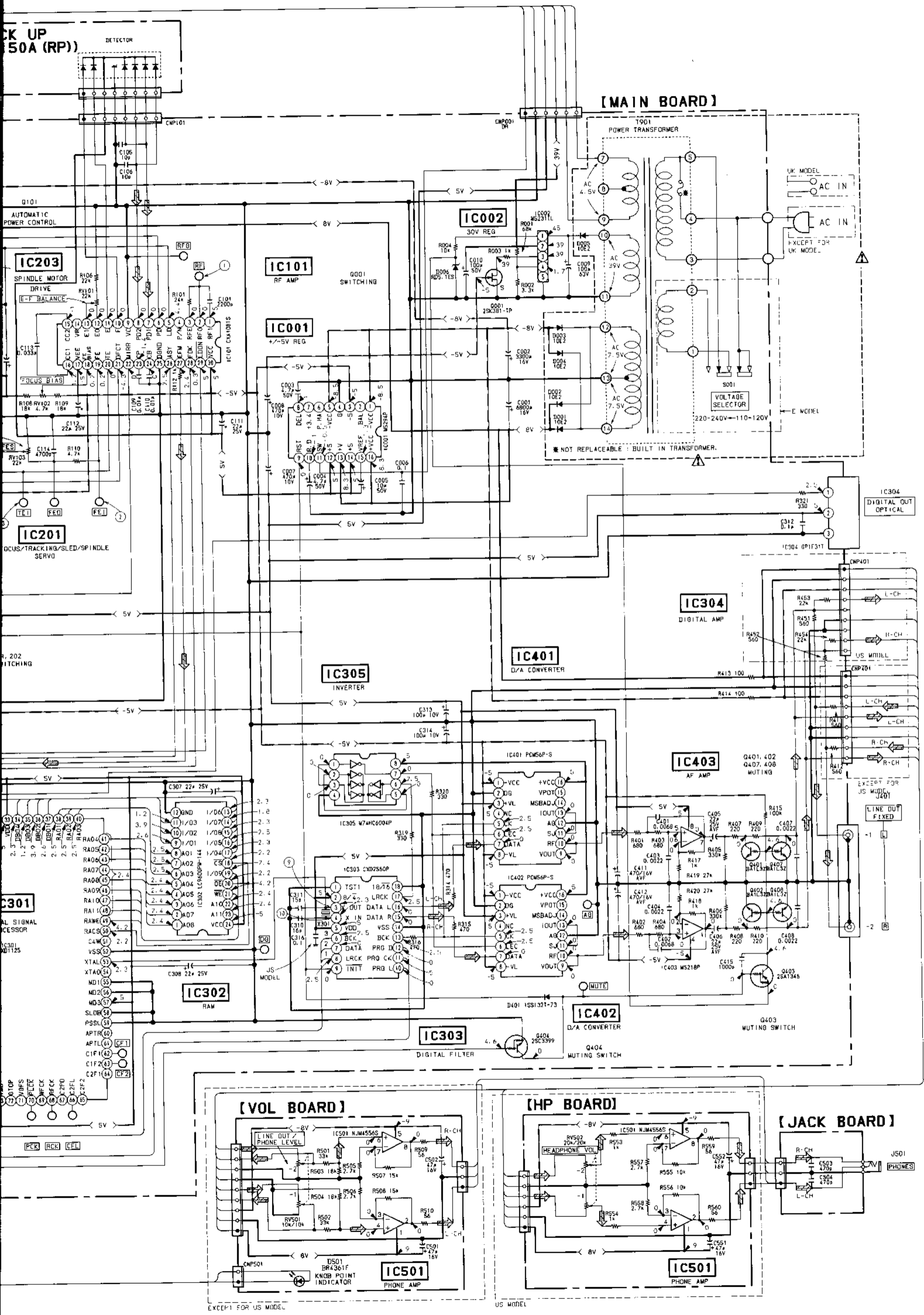

### [VOL BOARD]

### [HP BOARD]

### [JACK BOARD]

**• WAVE**

① RF PLAY

② FE

PLAY

③ TE

PLAY

④ VC

• All ca 50W and t

• All r speci

• Δ

• Voltage unde no m

• Voltage V

• Wave

• Voltage tion

• Circ

• Signa

**Note:**  
The co-ef by ted li are cri Repla number

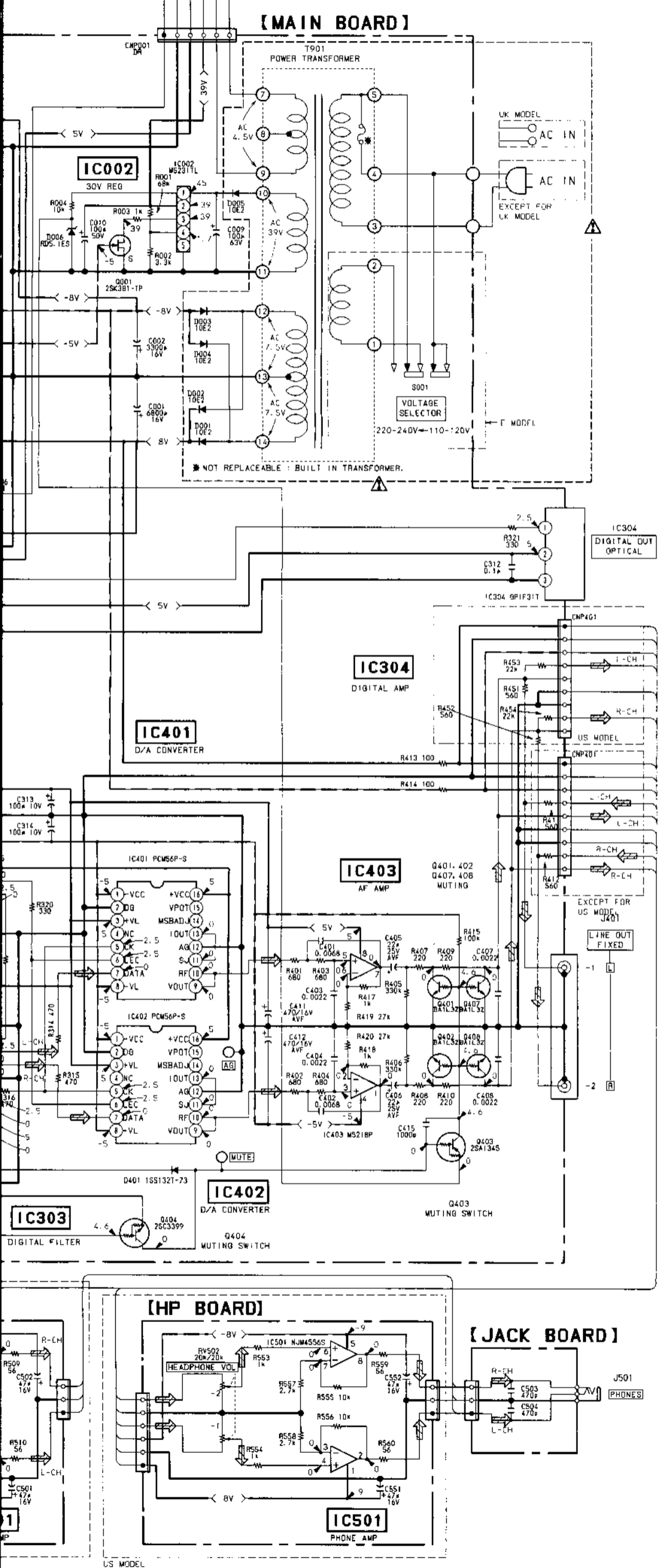

• WAVEFORMS

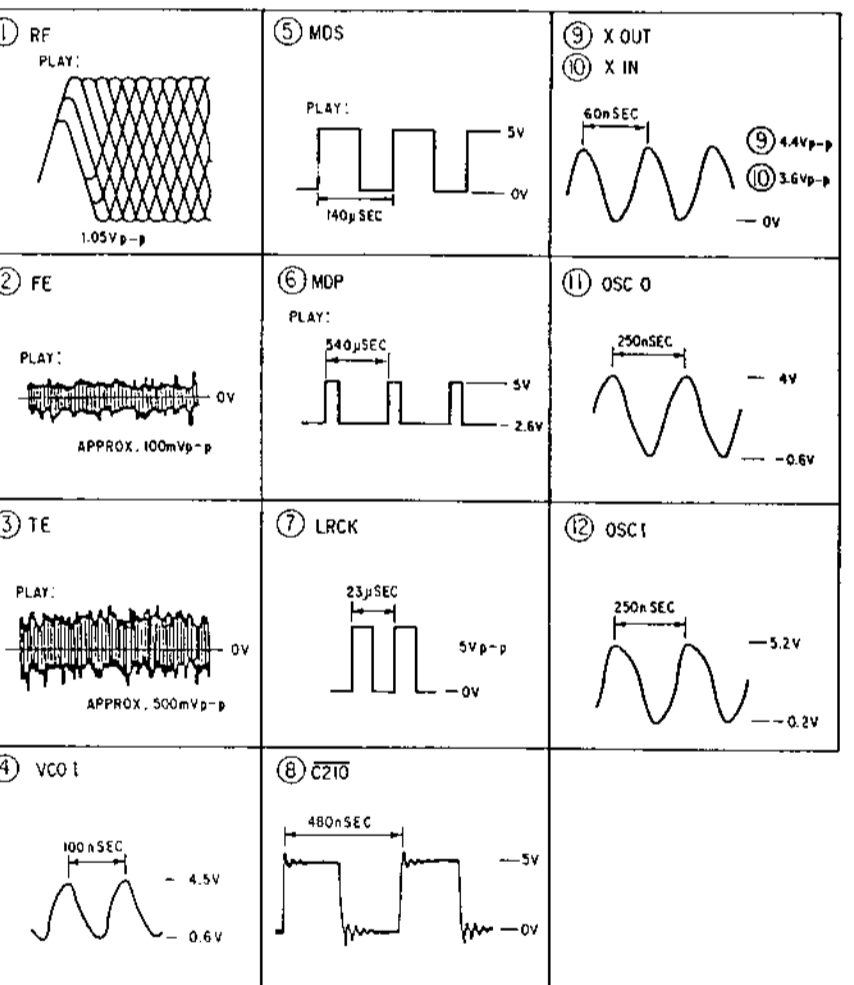

- All capacitors are in  $\mu\text{F}$  unless otherwise noted.  $\text{pF}$ :  $\mu\mu\text{F}$  50V or less are not indicated except for electrolytics and tantalums.
- All resistors are in  $\Omega$  and  $\frac{1}{4}\text{W}$  or less unless otherwise specified.
- $\Delta$  : internal component.
- $\text{---}$  : B+ Line
- $\text{---}$  : B- Line
- $\text{---}$  : adjustment for repair.
- Voltage and waveforms are dc with respect to ground under no-signal conditions. no mark : STOP
- Voltages are taken with a VOM (Input Impedance 10M $\Omega$ ). Voltage variations may be noted due to normal production tolerances.
- Waveforms are taken with an oscilloscope. Voltage variations may be noted due to normal production tolerances.
- Circled numbers refer to waveforms.
- Signal path.
- $\text{---}$  : CD

**Note:**  
The components identified by mark  $\Delta$  or dotted line with mark  $\Delta$  are critical for safety. Replace only with part number specified.

**Note:**  
Les composants identifiés par une marque  $\Delta$  sont critiques pour la sécurité. Ne les remplacer que par une pièce portant le numéro spécifié.

### 3-4. EXPLANATION OF IC601 (MSC6458-36SS)

IC601 have function of digit signal output to operation key, SUB Q signal taking in and management, tube (FLD) and control of servo system, etc.

#### 3-4-1. Pin Description

Pin No.	Symbol	I/O	Description
1	PLL SW	O	In play "L", in serch "H".
2	CLK	O	Command transmission clock to SSP (IC201) and DSP (IC301).
3	DATA	O	Command transmission data to SSP (IC201) and DSP (IC301).
4	XLT	O	Command transmission ratch to SSP (IC201) and DSP (IC301).
5	PRGL	O	Command transmission ratch to DFIL (IC303).
6	SYNC OUT	O	NC
7	SENSE	I	SENSE information of SSP (IC201) and DSP (IC301).
8	—	I	NC
9	SIRCS	I	Remote control signal input.
10	SCOR	I	Q code read timing.
11	AF ADJ	I	NC
12	ADJ	I	Test mode on "L".
13	AMUTE	O	To MUTG of all mute DSP (IC301).
14	E MPS	O	NC
15	SUBQ	I	Subcode data.
16	SQCLK	O	Subcode data readout clock.
17	GFS	I	In CLV rock "H".
18	FOK	I	In FOCUS ON "H".
19	KEY 0	I	Key matrix input "H" active.
20	KEY 1	I	Key matrix input "H" active.
21	KEY 2	I	Key matrix input "H" active.
22	KEY 3	I	Key matrix input "H" active.
23	KEY 4	I	Key matrix input "H" active.
24	KEY 5	I	Key matrix input "H" active.
25	INSW	I	Loading in SW.
26	LDON	O	Laser ON/OFF.
27	OUT SW	I	Loading out SW.
28	LODOUT	O	Loading motor control.
29	LODIN	O	Loading motor control.
30	OSC I	I	Pulse input (4MHz)
31	OSC O	O	Pulse output (4MHz)
32	GND	—	GND
33	RESET	I	Reset input : In POWER ON "Input".
34	TEST	—	NC
35	VL DOWN	—	NC
36	VL UP	O	Volume up signal.

Pin No.	Symbol	I/O	Description
37	TIMER	O	NC
38	VL LAMP	O	Volume indicator.
39	8G	—	NC
40	7G	O	FLD timing output.
41	6G	O	FLD timing output.
42	5G	O	FLD timing output.
43	4G	O	FLD timing output.
44	3G	O	FLD timing output.
45	2G	O	FLD timing output.
46	1G	O	FLD timing output.
47	—	—	NC
48	o	O	FLD segment output.
49	n	O	FLD segment output.
50	m	O	FLD segment output.
51	+30V	—	+30V
52	l	O	FLD segment output.
53	k	O	FLD segment output.
54	j	O	FLD segment output.
55	i	O	FLD segment output.
56	h	O	FLD segment output.
57	g	O	FLD segment output.
58	f	O	FLD segment output.
59	e	O	FLD segment output.
60	d	O	FLD segment output.
61	c	O	FLD segment output.
62	b	O	FLD segment output.
63	a	O	FLD segment output.
64	VDD	—	Power supply (+5V)

IC101 CXA10

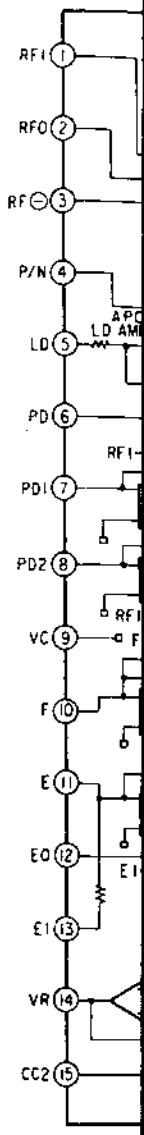

IC201 CXA10



IC101 CXA1081S

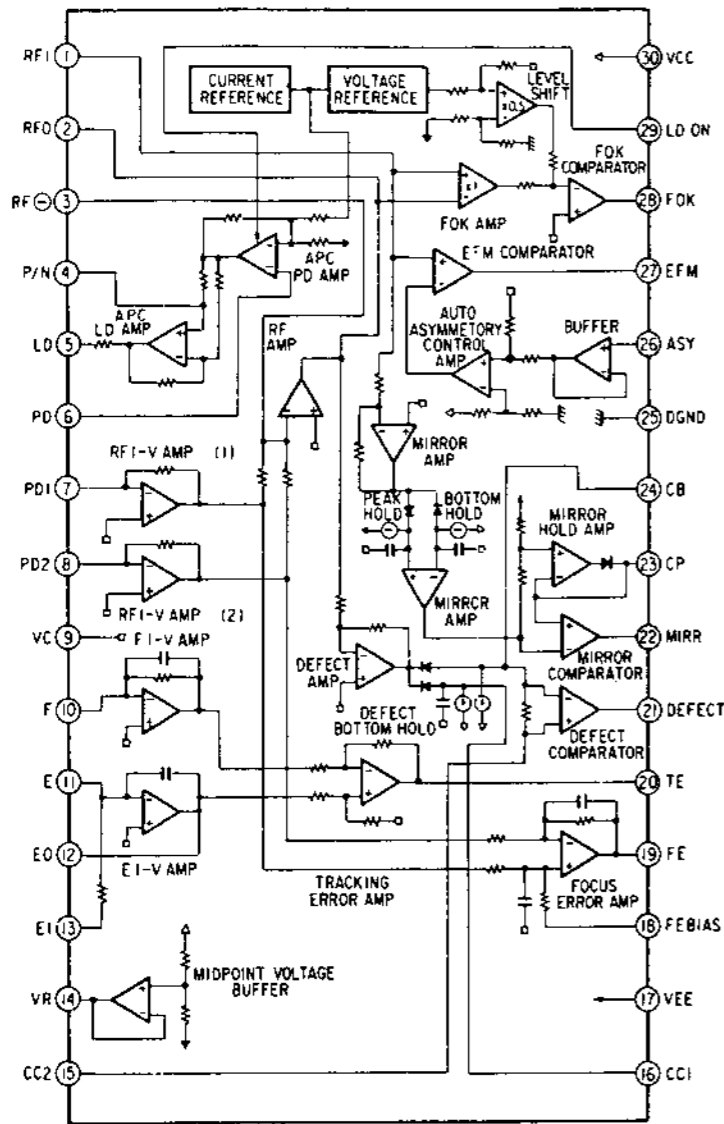

IC002 M5231TL

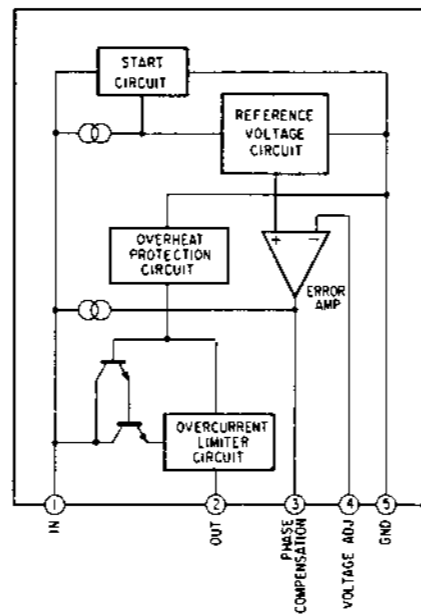

IC401, 402 PCM56P-S

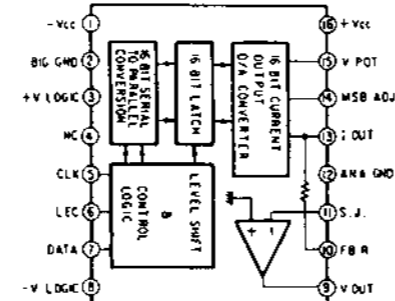

IC201 CXA1082BS

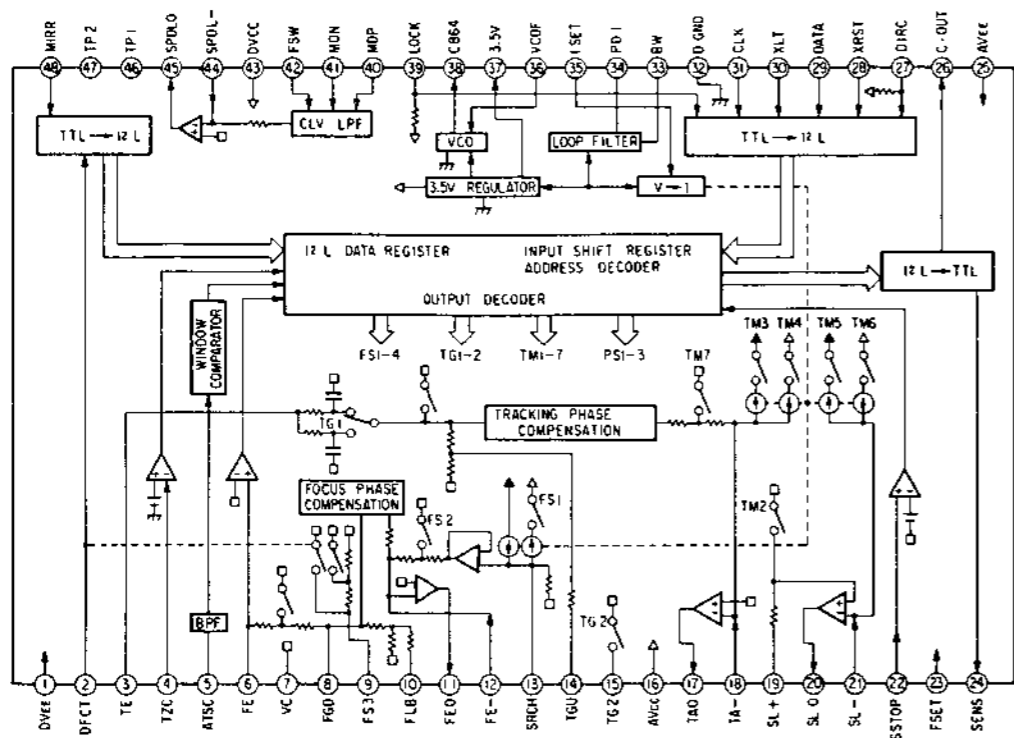

SECTION 4  
EXPLODED VIEWS

NOTE:

- The mechanical parts with no reference number in the exploded views are not supplied.
- The construction parts of an assembled part are indicated with a collation number in the remark column.
- Items marked "\*" are not stocked since they are seldom required for routine service. Some delay should be anticipated when ordering these items.

- Due to standardization, parts with part number suffix -XX and -X may be different from the parts specified in the components used on the set.
- Color Indication of Appearance Parts  
Example:  
(RED) ... KNOB, BALANCE (WHITE)  
↑ Cabinet's Color      ↑ Parts' Color

The components identified by mark or dotted line with mark are critical for safety. Replace only with part number specified.

Les composants identifiés par une marque sont critiques pour la sécurité. Ne les remplacer que par une pièce portant le numéro spécifié.

4-1. MAIN BLOCK

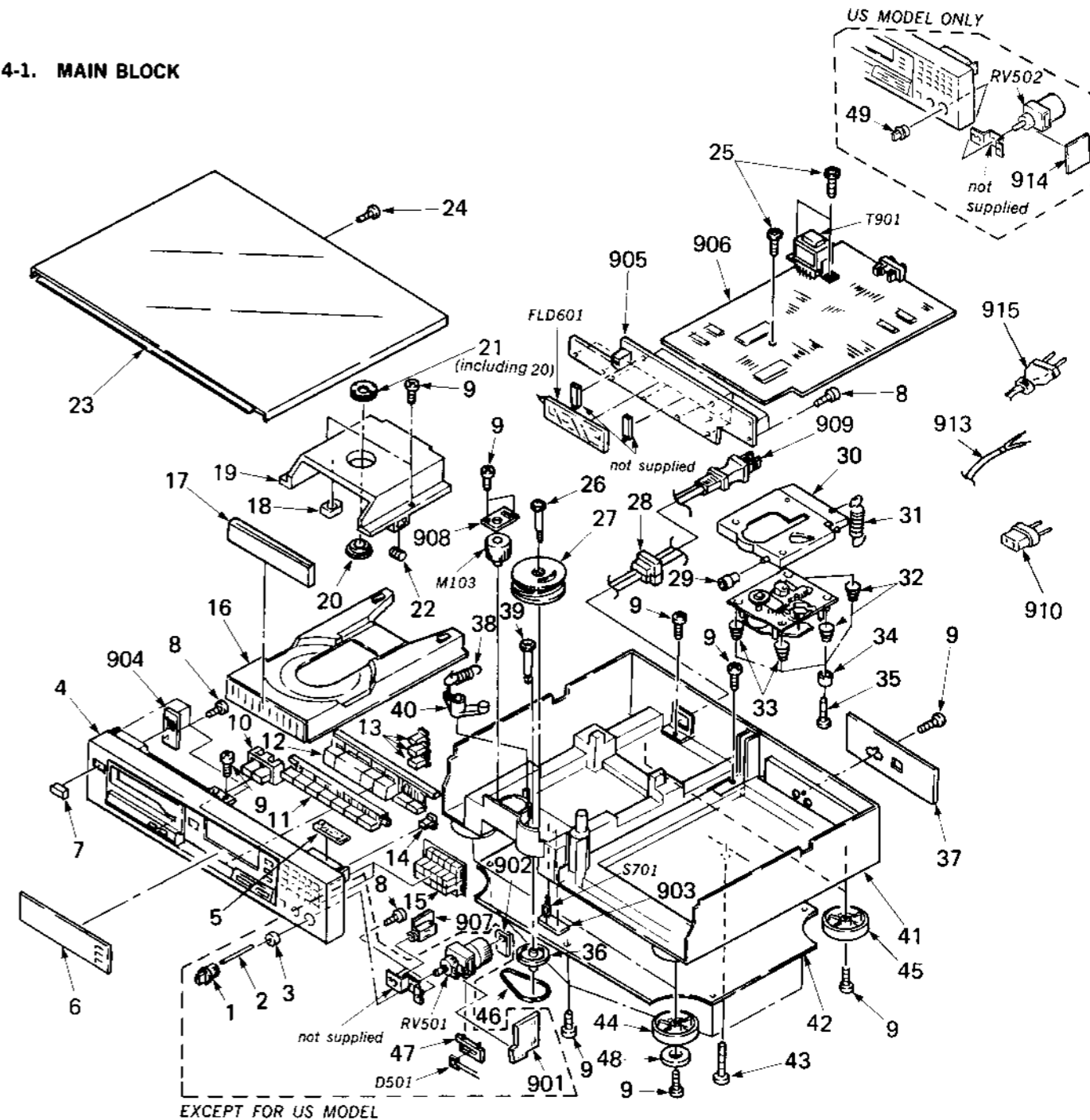

Ref.No	Part No.	Description	Remarks	Ref.No	Part No.	Description	Remarks
1	4-922-977-01	(EXCEPT FOR US)....KNOB (HP)		37	*4-922-959-41	(AEP)....PLATE (JACK), INDICATION	
2	4-922-979-01	(EXCEPT FOR US)....INDICATOR			*4-922-959-51	(E)....PLATE (JACK), INDICATION	
3	4-922-978-01	(EXCEPT FOR US)....HOLDER (FIBER)			*4-922-959-61	(UK)....PLATE (JACK), INDICATION	
4	A-4665-024-A	(AEP, UK, E)....PANEL ASSY, FRONT		38	4-917-514-01	SPRING, TENSION	
	X-4922-921-1	(US)....PANEL ASSY, FRONT		39	4-922-508-01	GEAR (DRIVING)	
	X-4922-922-1	(Canadian)....PANEL ASSY, FRONT		40	4-917-519-01	LEVER, SET	
5	3-831-441-XX	CUSHION		41	*4-925-346-01	CHASSIS	
6	4-922-966-01	PLATE, INDICATION		42	*4-922-960-01	PLATE, BOTTOM	
7	4-922-921-01	BUTTON (POWER)		43	7-685-878-01	SCREW +BVTT 3X25 (S)	
8	7-685-134-19	SCREW +BTP 2.6X8 TYPE2 N-S		44	X-4922-917-1	(AEP, UK)....FOOT ASSY (F)	
9	7-685-647-79	SCREW +BVTP 3X10 TYPE2 N-S		45	X-4922-918-1	(AEP, UK)....FOOT ASSY (R)	
10	4-922-964-01	BUTTON (T/R), CONTROL		46	4-917-522-02	BELT	
11	4-922-963-01	BUTTON (B), CONTROL		47	*4-922-980-01	(EXCEPT FOR US)....HOLDER (LED)	
12	4-922-962-01	BUTTON (A), CONTROL		48	4-922-942-01	(EXCEPT FOR UK)....FOOT (FELT)	
13	4-922-972-01	BUTTON (P/M)		49	4-922-531-01	(US)....KNOB (A TYPE), LOV	
14	4-922-976-01	BUTTON (C)		901	*1-628-252-11	(EXCEPT FOR US)....PC BOARD, VOL	
15	4-922-976-01	BUTTON (M/C)		902	*1-628-253-11	(EXCEPT FOR US)....PC BOARD, MOTOR	
16	*4-925-307-01	TABLE, DISK		903	*1-625-256-11	PC BOARD, IN/OUT SWITCH	
17	4-922-965-11	PANEL, LOADING		904	*1-628-254-11	PC BOARD, POWER SWITCH	
18	*4-922-529-01	DAMPER		905	*1-628-249-11	PC BOARD, DISPLAY	
19	*4-925-345-01	HOLDER (MG)		906	*A-4617-057-A	(US)....MOUNTED PCB, MAIN	
20	*4-918-679-04	PULLEY, PRESS			*A-4617-062-A	(E)....MOUNTED PCB, MAIN	
21	A-4665-024-A	MAGNET ASSY			*A-4651-217-A	(Canadian, AEP, UK)....MOUNTED PCB, MAIN	
22	4-925-335-01	SPRING, COMPRESSION		907	*1-628-251-11	PC BOARD, JACK	
23	4-925-348-01	CASE		908	*1-628-255-11	PC BOARD, LOADING MOTOR	
24	7-685-650-79	SCREW (2), TAPPING		909	△1-551-188-XX	(E)....CORD, POWER	
25	7-685-647-79	SCREW +BVTP 3X10 TYPE2 N-S			△1-557-577-11	(US, Canadian)....CORD, POWER	
26	7-685-152-19	SCREW, STEP		910	1-526-565-00	AC PLUG ADAPTOR	
27	4-925-306-01	GEAR (LOADING)		913	△1-556-035-00	(UK)....CORD, POWER	
28	3-703-571-11	(E)....BUSHING (S) (4516), CORD		914	*1-628-257-11	(US)....PC BOARD, HP	
	*3-703-244-00	(EXCEPT FOR E)....BUSHING (2104), CORD		915	△1-555-795-00	(AEP)....CORD, POWER, EULO PLUG	
29	4-917-515-01	ROLLER		FLD601	1-519-475-11	INDICATOR TUBE, FLUORESCENT	
30	*4-922-514-01	BRACKET (BU-5)		M103	A-4608-346-A	MOTOR ASSY, L (LOADING)	
31	4-917-526-01	SPRING, TENSION		RV501	1-238-314-11	(EXCEPT FOR US)....RES, VAR, CARBON 10K/10K (LINE OUT/PHONE LEVEL) (INCLUDING M901)	
32	4-917-507-01	SPRING (H)		RV502	1-238-478-11	(US)....RES, VAR, CARBON 20K/20K (HEADPHONE VOL)	
33	4-917-541-01	SPRING (B)		S701	1-571-300-11	SWITCH, ROTARY (IN/OUT)	
34	4-917-508-01	HOLDER, SP		T901	△1-449-024-11	(US, Canadian)....TRANSFORMER, POWER	
35	7-685-535-11	SCREW +BTP 2.6X10 TYPE2 N-S			△1-449-025-11	(AEP, UK)....TRANSFORMER, POWER	
36	4-922-512-01	PULLEY			△1-449-026-11	(E)....TRANSFORMER, POWER	
37	*4-922-959-11	(US)....PLATE (JACK), INDICATION					
	*4-922-959-31	(Canadian)....PLATE (JACK), INDICATION					

4-2. OPTICAL PICK-UP BLOCK  
(BU-5C)

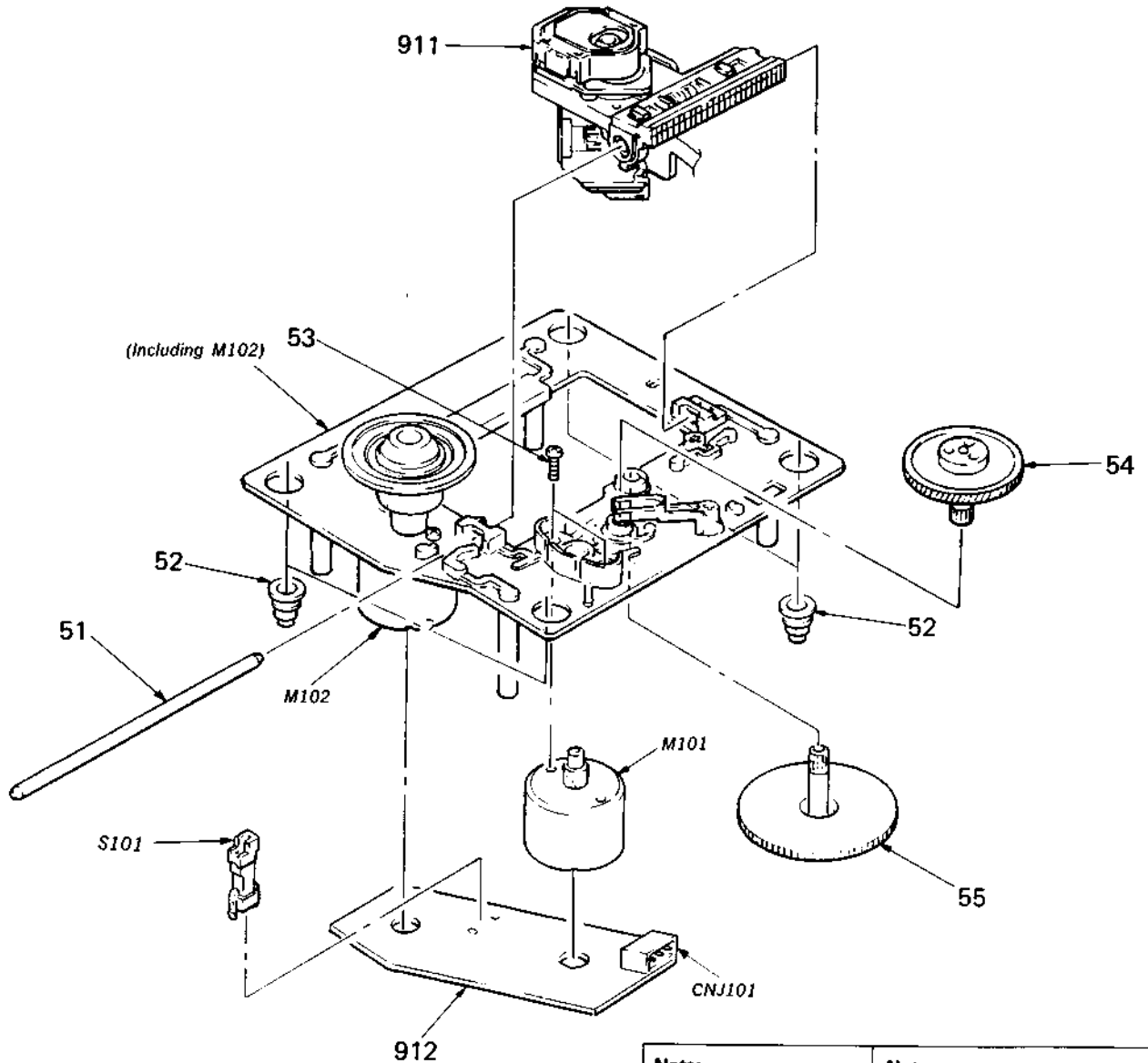

**Note:**  
The components identified by mark  $\Delta$  or dotted line with mark  $\Delta$  are critical for safety. Replace only with part number specified.

**Note:**  
Les composants identifiés par une marque  $\Delta$  sont critiques pour la sécurité. Ne les remplacer que par une pièce portant le numéro spécifié.

Ref.No	Part No.	Description	Remarks
51	4-917-565-01	SHAFT, SLED	
52	4-917-562-01	INSULATOR	
53	7-621-255-15	SCREW +P 2X3	
54	4-917-567-01	GEAR (M)	
55	4-917-564-01	GEAR (P), FLATNESS	
911	$\Delta$ 8-848-062-01	DEVICE, OPTICAL KSS-150A(RP)	

Ref.No	Part No.	Description	Remarks
912	*1-626-304-11	PC BOARD, SL/SP MOTOR	
CNJ101	*1-564-720-11	PIN, CONNECTOR (SMALL TYPE) 4P	
M101	X-4917-504-1	MOTOR ASSY (SLED)	
M102	X-4917-523-1	MOTOR ASSY (SPINDLE)	
S101	1-571-274-11	SWITCH, LEAF (LIMIT IN)	



## SECTION 5 ELECTRICAL PARTS LIST

**NOTE:**

- Due to standardization, replacements in the parts list may be different from the parts specified in the diagrams or the components used on the set.
- Items marked "★" are not stocked since they are seldom required for routine service. Some delay should be anticipated when ordering these items.
- If there are two or more same circuits in a set such as a stereophonic machine, only typical circuit parts may be indicated and capacitors and resistors in other same circuits may be omitted.

**CAPACITORS:**

MF:  $\mu$ F, PF:  $\mu$ F.

**RESISTORS**

- All resistors are in ohms.
- F: nonflammable

**COILS**

- MMH: mH, UH:  $\mu$ H

**SEMICONDUCTORS**

In each case, U:  $\mu$ , for example:  
 UA....:  $\mu$ A...., UPA....:  $\mu$ PA....,  
 UPC....:  $\mu$ PC, UPD....:  $\mu$ PD....

The components identified by mark  $\Delta$  or dotted line with mark  $\Delta$  are critical for safety. Replace only with part number specified.

Les composants identifiés par une marque  $\Delta$  sont critiques pour la sécurité. Ne les remplacer que par une pièce portant le numéro spécifié.

Ref.No	Part No.	Description	Ref.No	Part No.	Description			
901	*1-628-252-11	(EXCEPT FOR US)....PC BOARD, VOL	C214	1-124-499-11	ELECT	1MF	20%	50V
902	*1-628-253-11	(EXCEPT FOR US)....PC BOARD, MOTOR	C215	1-124-499-11	ELECT	1MF	20%	50V
903	*1-625-256-11	PC BOARD, IN/OUT SWITCH	C216	1-124-499-11	ELECT	1MF	20%	50V
904	*1-628-254-11	PC BOARD, POWER SWITCH	C217	1-161-375-00	CERAMIC	0.0022MF	30%	16V
905	*1-628-249-11	PC BOARD, DISPLAY	C218	1-162-291-31	CERAMIC	560PF	10%	50V
906	*A-4617-057-A	(US)....MOUNTED PCB, MAIN	C219	1-123-875-11	ELECT	10MF	20%	50V
	*A-4617-062-A	(E)....MOUNTED PCB, MAIN	C220	1-136-165-00	FILM	0.1MF	5%	50V
	*A-4651-217-A	(Canadian, AEP, UK)....MOUNTED PCB, MAIN	C225	1-126-101-11	ELECT	100MF	20%	16V
907	*1-628-251-11	PC BOARD, JACK	C226	1-126-101-11	ELECT	100MF	20%	16V
908	*1-628-255-11	PC BOARD, LOADING MOTOR	C227	1-126-101-11	ELECT	100MF	20%	16V
909	$\Delta$ 1-551-188-XX	(E)....CORD, POWER	C228	1-126-101-11	ELECT	100MF	20%	16V
	$\Delta$ 1-557-577-11	(US, Canadian)....CORD, POWER	C229	1-164-159-11	CERAMIC	0.1MF		50V
910	1-526-565-00	AC PLUG ADAPTOR	C230	1-164-159-11	CERAMIC	0.1MF		50V
911	$\Delta$ 8-848-062-01	DEVICE, OPTICAL KSS-150A(RP)	C301	1-124-902-00	ELECT	0.47MF	20%	50V
912	*1-626-304-11	PC BOARD, SL/SP MOTOR	C302	1-136-159-00	FILM	0.033MF	5%	50V
913	$\Delta$ 1-556-035-00	(UK)....CORD, POWER	C303	1-161-379-00	CERAMIC	0.01MF	20%	16V
914	*1-628-257-11	(US)....PC BOARD, HP	C304	1-124-902-00	ELECT	0.47MF	20%	50V
915	$\Delta$ 1-555-795-00	(AEP)....CORD, POWER, EULO PLUG	C305	1-124-499-11	ELECT	1MF	20%	50V
			C306	1-124-499-11	ELECT	1MF	20%	50V
			C307	1-126-233-11	ELECT	22MF	20%	25V
<b>CAPACITOR</b>								
C001	1-126-017-11	ELECT	6800MF	20%	16V			
C002	1-124-887-00	ELECT	3300MF	20%	16V			
C003	1-124-927-11	ELECT	4.7MF	20%	50V			
C004	1-124-927-11	ELECT	4.7MF	20%	50V			
C005	1-123-875-11	ELECT	10MF	20%	50V			
C006	1-164-159-11	CERAMIC	0.1MF		50V			
C007	1-124-472-11	ELECT	470MF	20%	10V			
C008	1-124-472-11	ELECT	470MF	20%	10V			
C009	1-124-572-11	ELECT	100MF	20%	63V			
C010	1-124-122-11	ELECT	100MF	20%	50V			
C101	1-161-375-00	CERAMIC	0.0022MF	30%	16V			
C103	1-124-477-11	ELECT	47MF	20%	16V			
C104	1-162-294-31	CERAMIC	0.001MF	10%	50V			
C105	1-162-199-31	CERAMIC	10PF	5%	50V			
C106	1-162-199-31	CERAMIC	10PF	5%	50V			
C108	1-161-375-00	CERAMIC	0.0022MF	30%	16V			
C109	1-136-153-00	FILM	0.01MF	5%	50V			
C110	1-136-153-00	FILM	0.01MF	5%	50V			
C111	1-126-233-11	ELECT	22MF	20%	25V			
C112	1-126-233-11	ELECT	22MF	20%	25V			
C113	1-136-159-00	FILM	0.033MF	5%	50V			
C114	1-161-377-00	CERAMIC	0.0047MF	30%	16V			
C201	1-136-165-00	FILM	0.1MF	5%	50V			
C202	1-136-159-00	FILM	0.033MF	5%	50V			
C203	1-123-382-00	ELECT	3.3MF	20%	50V			
C204	1-136-165-00	FILM	0.1MF	5%	50V			
C205	1-161-379-00	CERAMIC	0.01MF	20%	16V			
C206	1-161-377-00	CERAMIC	0.0047MF	30%	16V			
C207	1-124-927-11	ELECT	4.7MF	20%	50V			
C208	1-124-477-11	ELECT	47MF	20%	16V			
C209	1-162-294-31	CERAMIC	0.001MF	10%	50V			
C210	1-162-282-31	CERAMIC	100PF	10%	50V			
C211	1-126-233-11	ELECT	22MF	20%	25V			
C212	1-126-233-11	ELECT	22MF	20%	25V			
C213	1-126-233-11	ELECT	22MF	20%	25V			
C308	1-126-233-11	ELECT	22MF	20%	25V			
C310	1-162-204-31	CERAMIC	16PF	5%	50V			
C311	1-162-203-31	CERAMIC	15PF	5%	50V			
C312	1-164-159-11	CERAMIC	0.1MF	5%	50V			
C313	1-124-443-00	ELECT	100MF	20%	10V			
C314	1-124-443-00	ELECT	100MF	20%	10V			
C315	1-136-173-00	FILM	0.47MF	5%	50V			
C316	1-164-159-11	(US)....CERAMIC	0.1MF		50V			
C401	1-130-481-00	MYLAR	0.0068MF	5%	50V			
C402	1-130-481-00	MYLAR	0.0068MF	5%	50V			
C403	1-130-475-00	MYLAR	0.0022MF	5%	50V			
C404	1-130-475-00	MYLAR	0.0022MF	5%	50V			
C405	1-123-330-00	ELECT	22MF	20%	25V			
C406	1-123-330-00	ELECT	22MF	20%	25V			
C407	1-130-475-00	MYLAR	0.0022MF	5%	50V			
C408	1-130-475-00	MYLAR	0.0022MF	5%	50V			
C411	1-126-103-11	ELECT	470MF	20%	16V			
C412	1-126-103-11	ELECT	470MF	20%	16V			
C415	1-162-294-31	CERAMIC	0.001MF	10%	50V			
C501	1-124-477-11	(EXCEPT FOR US) ....ELECT	47MF	20%	16V			
C502	1-124-477-11	(EXCEPT FOR US) ....ELECT	47MF	20%	16V			
C503	1-162-290-31	CERAMIC	470PF	10%	50V			
C504	1-162-290-31	CERAMIC	470PF	10%	50V			
C505	1-124-443-00	(EXCEPT FOR US) ....ELECT	100MF	20%	10V			
C506	1-124-443-00	(EXCEPT FOR US) ....ELECT	100MF	20%	10V			
C551	1-124-589-11	(US)....ELECT	47MF	20%	16V			
C552	1-124-589-11	(US)....ELECT	47MF	20%	16V			
C601	1-164-159-11	CERAMIC	0.1MF		50V			
C602	1-164-159-11	CERAMIC	0.1MF		50V			
C603	1-162-290-31	CERAMIC	470PF	10%	50V			
C604	1-162-290-31	CERAMIC	470PF	10%	50V			

Ref.No	Part No.	Description
C605	1-162-290-31	CERAMIC 470PF 10% 50V
C606	1-164-159-11	CERAMIC 0.1MF 50V
CNJ101	* 1-564-720-11	PIN, CONNECTOR (SMALL TYPE) 4P
CNJ604	1-535-743-11	JUMPER, FILM (WITH TERMINAL)
CNP001	* 1-564-340-00	PIN, CONNECTOR 6P
CNP102	* 1-564-710-11	PIN, CONNECTOR (SMALL TYPE) 8P
CNP201	* 1-564-706-11	PIN, CONNECTOR (SMALL TYPE) 4P
CNP202	* 1-564-339-00	PIN, CONNECTOR 5P
CNP203	* 1-564-336-61	(EXCEPT FOR US)....PIN, CONNECTOR 2P
CNP204	1-566-908-11	SOCKET, CONNECTOR 32P
CNP401	* 1-564-711-11	PIN, CONNECTOR (SMALL TYPE) 9P
CNP501	* 1-564-336-00	(EXCEPT FOR US)....PIN, CONNECTOR 2P
CNP602	* 1-564-497-11	PIN, CONNECTOR 4P
CNP801	* 1-564-495-11	PIN, CONNECTOR 2P
D001	△.8-719-200-02	DIODE 10E2
D002	△.8-719-200-02	DIODE 10E2
D003	△.8-719-200-02	DIODE 10E2
D004	△.8-719-200-02	DIODE 10E2
D005	△.8-719-200-02	DIODE 10E2
D006	8-719-109-85	DIODE RD5.1ES-B2
D401	8-719-107-94	DIODE ISS202-1
D501	8-719-970-49	(EXCEPT FOR US)....DIODE BR4361F
D601	8-719-000-26	DIODE US1060M
D602	8-719-000-26	DIODE US1060M
D603	8-719-000-26	DIODE US1060M
D604	8-719-000-26	DIODE US1060M
D605	8-719-000-26	DIODE US1060M
D606	8-719-000-26	DIODE US1060M
D607	8-719-000-26	DIODE US1060M
D608	8-719-933-57	DIODE HZS9B2L
FLD501	1-519-475-11	INDICATOR TUBE, FLUORESCENT
IB101	1-233-171-11	COMPOSITION CIRCUIT BLOCK
IB102	1-233-171-11	COMPOSITION CIRCUIT BLOCK
IC001	8-759-631-40	IC M5294P
IC002	8-759-605-43	IC M5231TL
IC101	8-752-034-00	IC CXA1081S
IC201	8-752-032-30	IC CXA1082BS
IC202	8-752-035-28	IC CXA1291P
IC203	8-752-035-28	IC CXA1291P
IC301	8-752-328-62	IC CXD1125Q
IC302	8-752-323-64	IC CXK5816M-12L
IC303	8-752-328-72	IC CXD2550P
IC304	8-759-977-71	IC GP1F31T (DIGITAL OUT OPTICAL)
IC305	8-759-605-44	IC M74HC6004P
IC401	8-759-937-95	IC PCM56P-S
IC402	8-759-937-95	IC PCM56P-S
IC403	8-759-945-58	IC RC4558P
IC501	8-759-981-89	IC RC4556S
IC601	8-759-980-34	IC MSC6458-36SS
IC602	8-749-920-03	IC GP1U52
J401	* 1-562-999-21	JACK, PIN 2P (LINE OUT FIXED)
J501	1-507-796-71	JACK, LARGE TYPE (PHONES)
M101	X-4917-504-1	MOTOR ASSY (SLED)
M102	X-4917-523-1	MOTOR ASSY (SPINDLE)
M103	A-4608-346-A	MOTOR ASSY, L (LOADING)
Q001	8-729-600-95	TRANSISTOR 2SK381-C
Q101	8-729-801-83	TRANSISTOR 2SB1013
Q201	8-729-900-80	TRANSISTOR DTC114ES
Q202	8-729-900-89	TRANSISTOR DTC144ES
Q301	8-729-900-89	TRANSISTOR DTC144ES
Q401	8-729-900-74	TRANSISTOR DTC143ES

Ref.No	Part No.	Description
Q402	8-729-900-74	TRANSISTOR DTC143ES
Q403	8-729-900-65	TRANSISTOR DTA144ES
Q404	8-729-900-89	TRANSISTOR DTC144ES
Q407	8-729-900-74	TRANSISTOR DTC143ES
Q408	8-729-900-74	TRANSISTOR DTC143ES
Q601	8-729-900-45	TRANSISTOR DTC114EF
Q602	8-729-900-45	TRANSISTOR DTC114EF
Q603	8-729-900-45	TRANSISTOR DTC114EF
<b>RESISTOR</b>		
R001	1-249-439-11	CARBON 68K 5% 1/4W
R002	1-249-423-11	CARBON 3.3K 5% 1/4W
R003	1-249-417-11	CARBON 1K 5% 1/4W
R004	1-249-429-11	CARBON 10K 5% 1/4W
R101	1-247-864-11	CARBON 24K 5% 1/4W
R104	1-249-397-11	CARBON 22 5% 1/4W
R105	1-247-806-11	CARBON 91 5% 1/4W
R106	1-249-433-11	CARBON 22K 5% 1/4W
R108	1-249-432-11	CARBON 18K 5% 1/4W
R109	1-249-432-11	CARBON 18K 5% 1/4W
R110	1-249-425-11	CARBON 4.7K 5% 1/4W
R111	1-249-425-11	CARBON 4.7K 5% 1/4W
R112	1-249-417-11	CARBON 1K 5% 1/4W
R201	1-247-882-11	CARBON 130K 5% 1/4W
R202	1-249-432-11	CARBON 18K 5% 1/4W
R203	1-249-432-11	CARBON 18K 5% 1/4W
R204	1-249-440-11	CARBON 82K 5% 1/4W
R205	1-247-889-00	CARBON 270K 5% 1/4W
R206	1-249-435-11	CARBON 33K 5% 1/4W
R207	1-249-423-11	CARBON 3.3K 5% 1/4W
R208	1-249-425-11	CARBON 4.7K 5% 1/4W
R209	1-247-896-11	CARBON 510K 5% 1/4W
R210	1-249-417-11	CARBON 1K 5% 1/4W
R211	1-249-414-11	CARBON 560 5% 1/4W
R212	1-249-433-11	CARBON 22K 5% 1/4W
R213	1-249-441-11	CARBON 100K 5% 1/4W
R214	1-215-434-00	METAL 3.6K 1% 1/6W
R215	1-249-441-11	CARBON 100K 5% 1/4W
R216	1-249-429-11	CARBON 10K 5% 1/4W
R217	1-247-881-00	CARBON 120K 5% 1/4W
R218	1-249-427-11	CARBON 6.8K 5% 1/4W
R219	1-249-435-11	CARBON 33K 5% 1/4W
R220	1-249-437-11	CARBON 47K 5% 1/4W
R221	1-247-882-11	CARBON 130K 5% 1/4W
R222	1-247-883-00	CARBON 150K 5% 1/4W
R223	1-247-882-11	CARBON 130K 5% 1/4W
R224	1-247-883-00	CARBON 150K 5% 1/4W
R225	1-249-429-11	CARBON 10K 5% 1/4W
R226	1-249-441-11	(EXCEPT FOR US) ....CARBON 100K 5% 1/4W
R227	1-249-441-11	(EXCEPT FOR US) ....CARBON 100K 5% 1/4W
R228	1-249-441-11	(EXCEPT FOR US) ....CARBON 100K 5% 1/4W
R229	1-249-441-11	(EXCEPT FOR US) ....CARBON 100K 5% 1/4W
R230	1-249-393-11	CARBON 10 5% 1/4W
R231	1-249-393-11	CARBON 10 5% 1/4W
R232	1-249-425-11	CARBON 4.7K 5% 1/4W
R236	1-249-417-11	CARBON 1K 5% 1/4W
R237	1-249-417-11	CARBON 1K 5% 1/4W
R238	1-249-417-11	CARBON 1K 5% 1/4W
R239	1-249-417-11	CARBON 1K 5% 1/4W
R301	1-247-903-00	CARBON 1M 5% 1/4W
R302	1-249-433-11	CARBON 22K 5% 1/4W
R303	1-249-429-11	CARBON 10K 5% 1/4W

**Note:**  
The components identified by mark **△** or dotted line with mark **△** are critical for safety. Replace only with part number specified.

**Note:**  
Les composants identifiés par une marque **△** sont critiques pour la sécurité. Ne les remplacer que par une pièce portant le numéro spécifié.

Ref.No	Part No.	Description					
R304	1-249-441-11	CARBON	100K	5%	1/4W		
R305	1-249-441-11	CARBON	100K	5%	1/4W		
R306	1-249-429-11	CARBON	10K	5%	1/4W		
R307	1-215-469-00	METAL	100K	1%	1/6W		
R308	1-215-469-00	METAL	100K	1%	1/6W		
R310	1-249-421-11	CARBON	2.2K	5%	1/4W		
R311	1-249-421-11	CARBON	2.2K	5%	1/4W		
R312	1-249-421-11	CARBON	2.2K	5%	1/4W		
R314	1-249-413-11	CARBON	470	5%	1/4W		
R315	1-249-413-11	CARBON	470	5%	1/4W		
R316	1-249-413-11	CARBON	470	5%	1/4W		
R318	1-249-429-11	CARBON	10K	5%	1/4W		
R319	1-249-411-11	CARBON	330	5%	1/4W		
R320	1-249-411-11	CARBON	330	5%	1/4W		
R321	1-249-411-11	CARBON	330	5%	1/4W		
R401	1-249-415-11	CARBON	680	5%	1/4W		
R402	1-249-415-11	CARBON	680	5%	1/4W		
R403	1-249-415-11	CARBON	680	5%	1/4W		
R404	1-249-415-11	CARBON	680	5%	1/4W		
R405	1-247-891-00	CARBON	330K	5%	1/4W		
R406	1-247-891-00	CARBON	330K	5%	1/4W		
R407	1-249-409-11	CARBON	220	5%	1/4W		
R408	1-249-409-11	CARBON	220	5%	1/4W		
R409	1-249-409-11	CARBON	220	5%	1/4W		
R410	1-249-409-11	CARBON	220	5%	1/4W		
R411	1-249-414-11	(EXCEPT FOR US) ... CARBON	560	5%	1/4W		
R412	1-249-414-11	(EXCEPT FOR US) ... CARBON	560	5%	1/4W		
R413	1-249-405-11	CARBON	100	5%	1/4W		
R414	1-249-405-11	CARBON	100	5%	1/4W		
R415	1-249-441-11	CARBON	100K	5%	1/4W		
R417	1-249-417-11	CARBON	1K	5%	1/4W		
R418	1-249-417-11	CARBON	1K	5%	1/4W		
R419	1-249-434-11	CARBON	27K	5%	1/4W		
R420	1-249-434-11	CARBON	27K	5%	1/4W		
R451	1-249-414-11	(US)... CARBON	560	5%	1/4W		
R452	1-249-414-11	(US)... CARBON	560	5%	1/4W		
R453	1-249-433-11	(US)... CARBON	22K	5%	1/4W		
R454	1-249-433-11	(US)... CARBON	22K	5%	1/4W		
R501	1-249-435-11	(EXCEPT FOR US) ... CARBON	33K	5%	1/4W		
R502	1-249-435-11	(EXCEPT FOR US) ... CARBON	33K	5%	1/4W		
R503	1-249-432-11	(EXCEPT FOR US) ... CARBON	18K	5%	1/4W		
R504	1-249-432-11	(EXCEPT FOR US) ... CARBON	18K	5%	1/4W		
R505	1-249-422-11	(EXCEPT FOR US) ... CARBON	2.7K	5%	1/4W		
R506	1-249-422-11	(EXCEPT FOR US) ... CARBON	2.7K	5%	1/4W		
R507	1-249-431-11	(EXCEPT FOR US) ... CARBON	15K	5%	1/4W		
R508	1-249-431-11	(EXCEPT FOR US) ... CARBON	15K	5%	1/4W		
R509	1-249-402-11	(EXCEPT FOR US) ... CARBON	56	5%	1/4W		
R510	1-249-402-11	(EXCEPT FOR US) ... CARBON	56	5%	1/4W		
R553	1-249-417-11	(US)... CARBON	1K	5%	1/4W		
R554	1-249-417-11	(US)... CARBON	1K	5%	1/4W		
R555	1-249-429-11	(US)... CARBON	10K	5%	1/4W		
R556	1-249-429-11	(US)... CARBON	10K	5%	1/4W		
R557	1-249-422-11	(US)... CARBON	2.7K	5%	1/4W		
R558	1-249-422-11	(US)... CARBON	2.7K	5%	1/4W		
R559	1-249-402-11	(US)... CARBON	56	5%	1/4W		
R560	1-249-402-11	(US)... CARBON	56	5%	1/4W		
R601	1-249-435-11	CARBON	33K	5%	1/4W		
R602	1-249-435-11	CARBON	33K	5%	1/4W		
R603	1-249-435-11	CARBON	33K	5%	1/4W		
R604	1-249-435-11	CARBON	33K	5%	1/4W		
R605	1-249-435-11	CARBON	33K	5%	1/4W		
R606	1-249-435-11	CARBON	33K	5%	1/4W		
R607	1-249-435-11	CARBON	33K	5%	1/4W		
R609	1-249-411-11	(EXCEPT FOR US) ... CARBON	330	5%	1/4W		
RV101	1-228-995-00	RES. ADJ. CARBON	22K				
RV102	1-228-993-00	RES. ADJ. CARBON	4.7K				
RV103	1-228-995-00	RES. ADJ. CARBON	22K				
RV104	1-228-995-00	RES. ADJ. CARBON	22K				
RV201	1-228-990-00	RES. ADJ. METAL GLAZE	1K				
RV501	1-238-314-11	(EXCEPT FOR US)... RES. VAR. CARBON	10K/10K				
RV502	1-238-478-11	(US)... RES. VAR. CARBON	20K/20K (HEADPHONE VOL)				
S001	△1-571-722-11	(E)... SWITCH, VOLTAGE SELECTION (VOLTAGE SELECTOR)					
S101	1-571-274-11	SWITCH, LEAF (LIMIT IN)					
S601	1-554-596-21	SWITCH, KEY BOARD (17)					
S602	1-554-596-21	SWITCH, KEY BOARD (18)					
S603	1-554-596-21	SWITCH, KEY BOARD (19)					
S604	1-554-596-21	SWITCH, KEY BOARD (20)					
S605	1-554-596-21	SWITCH, KEY BOARD (16)					
S606	1-554-596-21	SWITCH, KEY BOARD (11)					
S607	1-554-596-21	SWITCH, KEY BOARD (12)					
S608	1-554-596-21	SWITCH, KEY BOARD (13)					
S609	1-554-596-21	SWITCH, KEY BOARD (14)					
S610	1-554-596-21	SWITCH, KEY BOARD (15)					
S611	1-554-596-21	SWITCH, KEY BOARD (>20)					
S612	1-554-596-21	SWITCH, KEY BOARD (6)					
S613	1-554-596-21	SWITCH, KEY BOARD (7)					
S614	1-554-596-21	SWITCH, KEY BOARD (8)					
S615	1-554-596-21	SWITCH, KEY BOARD (9)					
S616	1-554-596-21	SWITCH, KEY BOARD (10)					
S617	1-554-596-21	SWITCH, KEY BOARD (FADER)					
S618	1-554-596-21	SWITCH, KEY BOARD (1)					
S619	1-554-596-21	SWITCH, KEY BOARD (2)					
S620	1-554-596-21	SWITCH, KEY BOARD (3)					
S621	1-554-596-21	SWITCH, KEY BOARD (4)					
S622	1-554-596-21	SWITCH, KEY BOARD (5)					
S623	1-554-596-21	SWITCH, KEY BOARD (◀)					
S624	1-554-596-21	SWITCH, KEY BOARD (▶▶)					
S625	1-554-596-21	SWITCH, KEY BOARD (EDIT/TIME FADE)					
S626	1-554-596-21	SWITCH, KEY BOARD (CHECK)					
S627	1-554-596-21	SWITCH, KEY BOARD (CLEAR)					
S628	1-554-596-21	SWITCH, KEY BOARD (◀◀)					
S629	1-554-596-21	SWITCH, KEY BOARD (▶▶)					
S630	1-554-596-21	SWITCH, KEY BOARD (⊆) OPEN/CLOSE)					
S631	1-554-596-21	SWITCH, KEY BOARD (▶)					
S632	1-554-596-21	SWITCH, KEY BOARD (◻)					
S633	1-554-596-21	SWITCH, KEY BOARD (■)					
S634	1-554-596-21	SWITCH, KEY BOARD (TIME)					
S635	1-554-596-21	SWITCH, KEY BOARD (AUTO SPACE)					
S636	1-554-596-21	SWITCH, KEY BOARD (REPEAT)					
S637	1-554-596-21	SWITCH, KEY BOARD (PROGRAM)					
S638	1-554-596-21	SWITCH, KEY BOARD (SHUFFLE)					
S639	1-554-596-21	SWITCH, KEY BOARD (CONTINUE/SINGLE)					
S640	1-571-305-11	SWITCH, PUSH (1 KEY) (POWER)					
S701	1-571-300-11	SWITCH, ROTARY (IN/OUT)					
T901	△1-449-024-11	(US, Canadian)... TRANSFORMER, POWER					
T901	△1-449-025-11	(AEP, UK)... TRANSFORMER, POWER					

**Note:**  
The components identified by mark △ or dotted line with mark △ are critical for safety. Replace only with part number specified.

**Note:**  
Les composants identifiés par une marque △ sont critiques pour la sécurité. Ne les remplacer que par une pièce portant le numéro spécifié.

<u>Ref.No</u>	<u>Part No.</u>	<u>Description</u>
T901	△-1-449-026-11	(E)... TRANSFORMER, POWER
X301	1-567-926-11	VIBRATOR, CRYSTAL
X601	1-577-082-11	VIBRATOR, CERAMIC (4MHz)

ACCESSORY & PACKING MATERIAL  
\*\*\*\*\*

1-465-049-11	(EXCEPT FOR US)...	REMOTE COMMANDER
1-465-051-11	(US)...	REMOTE COMMANDER
1-558-543-11		CORD, CONNECTION
1-559-533-11		CORD, CONNECTION
*3-704-339-01	SHEET (STANDARD),	PROTECTION
3-786-456-11	(EXCEPT FOR US)...	MANUAL, INSTRUCTION
3-786-456-21	(US)...	MANUAL, INSTRUCTION
3-786-456-41	(AEP)...	MANUAL, INSTRUCTION
*3-795-629-11	(AEP)...	INSTRUCTION
4-928-079-01		COVER, BATTERY
*4-885-838-00	(AEP, UK, E)...	LABEL, CLASS 1
*4-925-388-01		INDIVIDUAL CARTON
*4-925-389-01		CUSHION

**Note:**

The components identified by mark △ or dotted line with mark △ are critical for safety. Replace only with part number specified.

**Note:**

Les composants identifiés par une marque △ sont critiques pour la sécurité. Ne les remplacer que par une pièce portant le numéro spécifié.