

CDP-701ES

(RM-101)

US Model
Canadian Model
AEP Model
UK Model

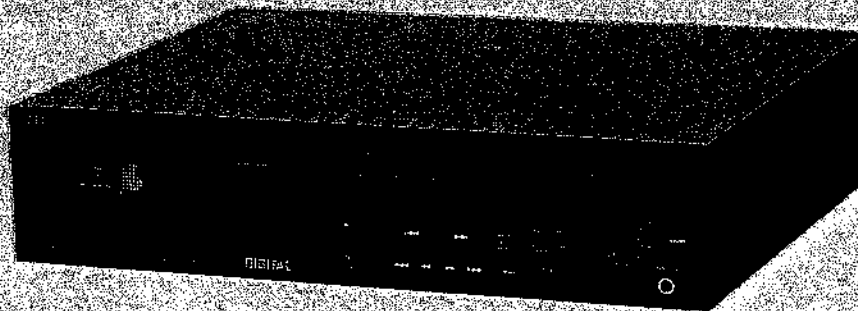

COMPACT DISC PLAYER

SPECIFICATIONS

System Compact disc digital audio system
Disc Compact disc
Laser Semiconductor laser
Spindle speed 200 r.p.m. to 500 r.p.m. (CLV)
Scan velocity 1.2 - 1.4 m/sec.
Error correction Sony Super Strategy Cross Interleave Reed Solomon Code

Number of channels 2
D-A conversion 16-bit linear
Frequency response 5 - 20,000 Hz ± 0.5 dB
Harmonic distortion Less than 0.003 % (1 kHz)
Dynamic range More than 95 dB
Channel separation More than 90 dB
Wow and flutter Below measurable limit
Outputs Line outputs
Output level 2 V rms (at MSB)
Load impedance over 10 kilohms
Headphones 28 mW at 32 ohms

Disc
Track pitch 1.6 μ m
Sampling frequency 44.1 kHz
Quantization 16 bit linear quantizing/channel
Modulation system EFM
Transfer rate 2.03 Mbit/sec. (before modulation)

ATTENTION AU COMPOSANT AYANT RAPPORT
À LA SÉCURITÉ!

LES COMPOSANTS IDENTIFIÉS PAR UNE TRAME ET UNE MARQUE \triangle SUR LES DIAGRAMMES SCHEMATIQUES ET LA LISTE DES PIÈCES SONT CRITIQUES POUR LA SÉCURITÉ DE FONCTIONNEMENT. NE REMPLACER CES COMPOSANTS QUE PAR DES PIÈCES SONY DONT LES NUMÉROS SONT DONNÉS DANS CE MANUEL OU DANS LES SUPPLÉMENTS PUBLIÉS PAR SONY.



Remote Commander RM-101
Remote control system

Infrared control
Power requirements 3 V dc with two batteries IEC designation R6 (size AA)
Dimensions Approx. 55 x 175 x 26 mm (w/h/d)
(2 1/4 x 7 x 1 1/16 inches)
incl. projecting parts and controls
Weight Approx. 150 g (5.3 oz)

General
Power requirements US, Canadian model: 120 V ac, 60 Hz
AEP model: 220 V ac, 50/60 Hz
UK model: 240 V ac, 50/60 Hz

Power consumption 38 W
Dimensions Approx. 430 x 105 x 385 mm (w/h/d)
(17 x 4 1/4 x 15 3/4 in.)
including projecting parts and controls
Weight Approx. 11.5 kg (25 lbs 6 oz), net

SAFETY-RELATED COMPONENT WARNING!!

COMPONENTS IDENTIFIED BY SHADING AND MARK \triangle ON THE SCHEMATIC DIAGRAMS AND IN THE PARTS LIST ARE CRITICAL TO SAFE OPERATION. REPLACE THESE COMPONENTS WITH SONY PARTS WHOSE PART NUMBERS APPEAR AS SHOWN IN THIS MANUAL OR IN SUPPLEMENTS PUBLISHED BY SONY.

SONY[®]

SERVICE MANUAL

PROTECTION OF EYES FROM LASER BEAM DURING SERVICING

This set employs a laser. Therefore, be sure to follow carefully the instructions below when servicing.

WARNING !!

WHEN SERVICING, DO NOT APPROACH THE LASER EXIT WITH THE EYE TOO CLOSELY. IN CASE IT IS NECESSARY TO CONFIRM LASER BEAM EMISSION, BE SURE TO OBSERVE FROM A DISTANCE OF MORE THAN 30 cm FROM THE SURFACE OF THE OBJECTIVE LENS ON THE OPTICAL PICK-UP BLOCK.

1. Laser Diode Properties

- Material: GaAs
- Wavelength: 780 nm
- Emission Duration: continuous
- Laser Output: max. 0.4 mW*

* This output is the value measured at a distance of about 1.6 mm from the objective lens surface on the Optical Pick-up Block.

- Classification: Class IIIb

2. During service, do not take the Optical Pick-up Block apart, and do not adjust the APC circuit. If there is a breakdown in the APC circuit (including laser diode), replace the entire Optical Pick-up Block (including APC board).

LASER WARNING LABELS

The labels shown below are affixed.

1. Protective Housing Label

- 1) DHHS Protective Housing Label (US model only)



- See figure on next page for location of label.

- 2) DNHW Protective Housing Label and Laser Radiation Sign Label (Canadian model only)

DNHW Protective Housing Label



Laser Radiation Sign Label



- See figure on next page for location of label.

2. Aperture Label (AEP, UK model only)

LASER APERTURE

- See figure on next page for location of label.

3. Caution Label (AEP, UK model only)

CAUTION : INVISIBLE LASER RADIATION WHEN OPEN AND INTERLOCKS DEFEATED. AVOID EXPOSURE TO BEAM.
ADVARSEL : USYNLIG LASERSTRÅLING VED ÅBNING NÅR SIKKERHEDSafbrydere ER UDE AF FUNKTION UNDGÅ UDSETELSE FOR STRÅLING.

- See figure on next page for location of label.

● US, Canadian model

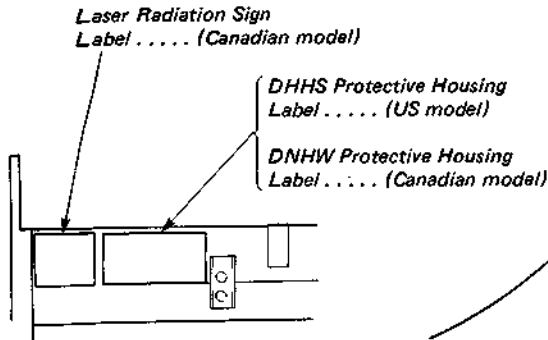

● AEP, UK model

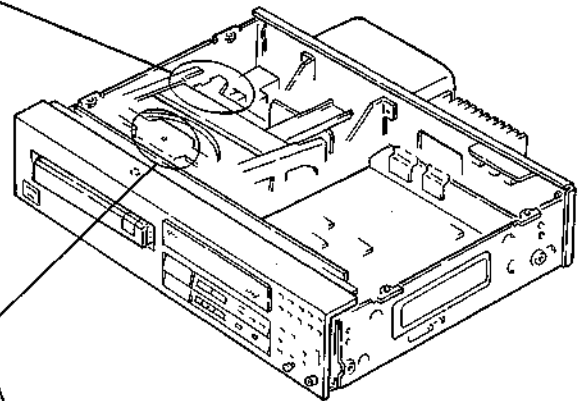
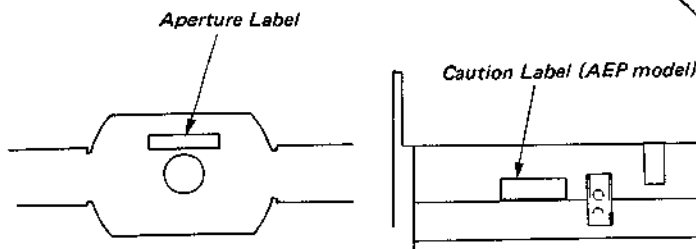

SAFETY CHECK-OUT (US Model)

After correcting the original service problem, perform the following safety check before releasing the set to the customer:

Check the antenna terminals, metal trim, "metallized" knobs, screws, and all other exposed metal parts for AC leakage. Check leakage as described below.

LEAKAGE TEST

The AC leakage from any exposed metal part to earth ground and from all exposed metal parts to any exposed metal part having a return to chassis, must not exceed 0.5 mA (500 microamperes). Leakage current can be measured by any one of three methods.

1. A commercial leakage tester, such as the Simpson 229 or RCA WT-540A. Follow the manufacturers' instructions to use these instruments.
2. A battery-operated AC milliammeter. The Data Precision 245 digital multimeter is suitable for this job.

3. Measuring the voltage drop across a resistor by means of a VOM or battery-operated AC voltmeter. The "limit" indication is 0.75 V, so analog meters must have an accurate low-voltage scale. The Simpson 250 and Sanwa SH-63Trd are examples of a passive VOM that is suitable. Nearly all battery operated digital multimeters that have a 2V AC range are suitable. (See Fig. A)

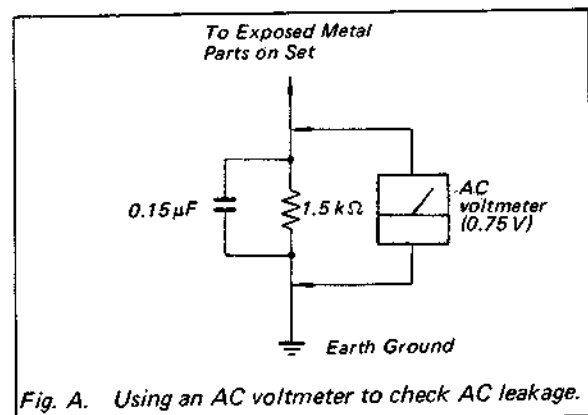

BESKYTTELSE AF ØJNE MOD LASERSTRÅLING UNDER SERVICE

I dette apparat anvendes laserlys. Derfor skal nedenstående instruktioner nøje følges under service.

Følg iverigt instruktionerne i servicemanualen.

ADVARSEL!!

Under service må øjnene ikke komme nær objektiv-linsen på den optiske pick-up enhed. I tilfælde af at det er nødvendigt at kontrollere udsendelsen af laserlys, skal det ske i en afstand af mere end 30 cm fra den optiske pick-up.

1. Data for Laser Diode

- Materiale: Ga-As
- Bølgelængde: 780 nm
- Udstråling: Kontinuerlig
- Laser Output: max. 0.4 mW*
* målt i 1.6 mm afstand fra overfladen af objektiv-linsen på den optiske pick-up enhed.
- Klassifikation: Svarende til klasse IIIb

2. Adskil aldrig den optiske pick-up enhed under service, og juster ikke APC kredsløbet (Automatic Power Control). Hvis APC kredsløbet (incl. laser-dioden) bryder ned, skal hele den optiske pick-up enhed (incl. APC printkortet) udskiftes.

LASER ADVARSEL MÆRKNING (AEP model)

Følgende mærkning findes indvendig i apparatet:

1. Advarsel Mærkning

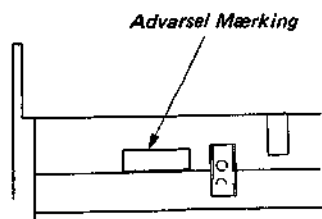
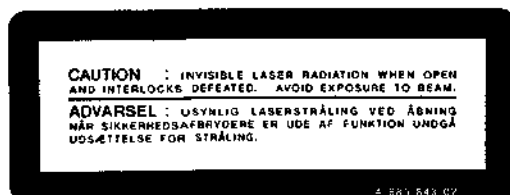

2. Aperture Label

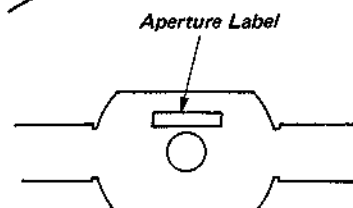
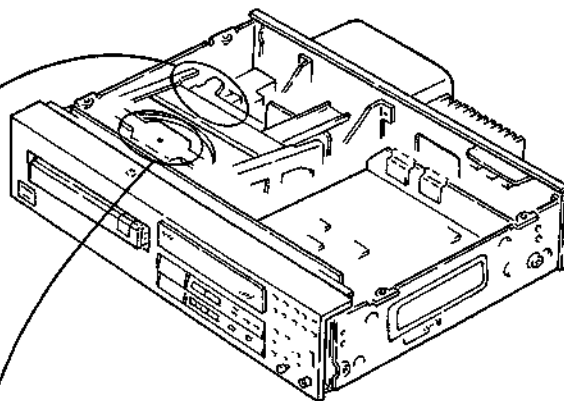

CDP-701ES

FEATURES

In the Compact Disc (CD) system, sound levels are converted to a series of binary codes and recorded as digital pulses of equal amplitude. The pulses are etched on the disc in the shape of tiny pits with a pitch of 1.6 μ m.

During playback, a laser beam focuses on the pits which reflect the laser light. Variations in the reflected light rays are then converted back into a continuous audio waveform.

Through this system, the CDP-701ES offers performance and sound fidelity far superior to any analog record and turntable system.

High performance and fidelity

With the CDP-701ES, flat frequency response (5 - 20,000 Hz), low wow and flutter (lower than the measurable limit), wide dynamic range (more than 95 dB), minimal distortion (0.003%) and high channel separation (more than 90 dB) are achieved. Listening to the sound reproduction of your CDP-701ES is just like being in the concert hall.

Full-logic "feather touch" operation

At the lightest touch, the "feather-touch" function buttons enable you to switch directly from one mode to another.

A variety of programmed play

Various data are recorded on compact discs together with the music signals to allow the following functions to operate.

- The AMS (Automatic Music Sensor) function for quickly locating the beginning of a desired selection.
- Music Scan function for locating a particular selection by playing the first 10 seconds of each selection in turn.
- The LOCATION function for starting play from a particular point of a particular selection.
- The RMS (Random Music Sensor) function for playing particular selections in any desired order.
- Three types of repeat functions: one for the entire disc, one for a portion of the disc, and one for a specific selection. Combined with the RMS function, repeat play of a desired sequence is also possible.

Multiple display

The elapsed playing time from the beginning of the selection, and the playing time remaining on the disc are displayed at the same time. The point on the disc being played is also shown on the disc scale in the display window.

Remote control operation

Using the supplied Remote Commander, various functions of the player as well as a 10-key music select function can be remotely controlled.

Non-contact signal readout system

Because a laser beam is employed for signal pick-up, there is no physical contact with the disc, which means no wear.

In addition, because the pit pattern is recorded below the surface of the disc, it is not necessary to be constantly on guard against dust, making it disc easy to handle.

MODEL IDENTIFICATION

— Specification Label —

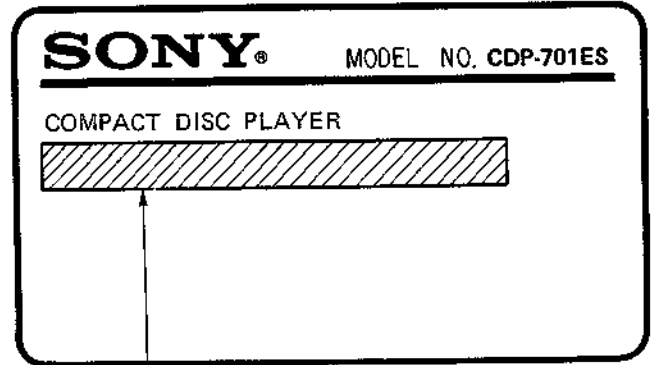

US, Canadian model . . .	AC: 120V	60Hz	38W
AEP model	AC: 220V	~ 50/60Hz	38W
UK model	AC: 240V	~ 50/60Hz	38W

— CAUTION FOR ELECTROSTATIC BREAKDOWN —

NOTES ON HANDLING THE OPTICAL PICK-UP BLOCK (KSC-100A)

The laser diode in the optical pick-up block may suffer electrostatic breakdown because of the potential difference generated by the charged electrostatic load, etc. on clothing and the human body.

The printed matter below is included in the repair parts. During repair, use the procedure in the printed matter.

The following method is an example for reference purposes:

1. Place a conductive sheet on the workbench. (The black sheet used as repair parts wrapping.)
2. Place the set on the conductive sheet so that the chassis touches the sheet. (This makes it the same potential as the conductive sheet.)
3. Place your hands on the conductive sheet. (This makes them the same potential as the sheet.)
4. Remove the optical pick-up block from the bag (conductive).
5. Perform work on top of the conductive sheet. Be careful that clothing does not touch the optical pick-up block.

Printed Matter Included in the Repair Parts

When opening or repairing a KSC-100A, the procedure for grounding as follows is required to prevent damage caused by static electricity.

- 1 Grounding for the human body
Be sure to put on a wrist-strap for grounding (with impedance lower than $10^8 \Omega$) whose other end is grounded. The strap works to drain away the static electricity build-up on the human body.
- 2 Grounding for the work table
Be sure to lay on the table a conductive sheet (with impedance lower than $10^9 \Omega$) such as a sheet of copper, which is grounded.
- 3 As static electricity build-up on clothes is not drained away, be careful not to let your clothes touch the KSC-100A.

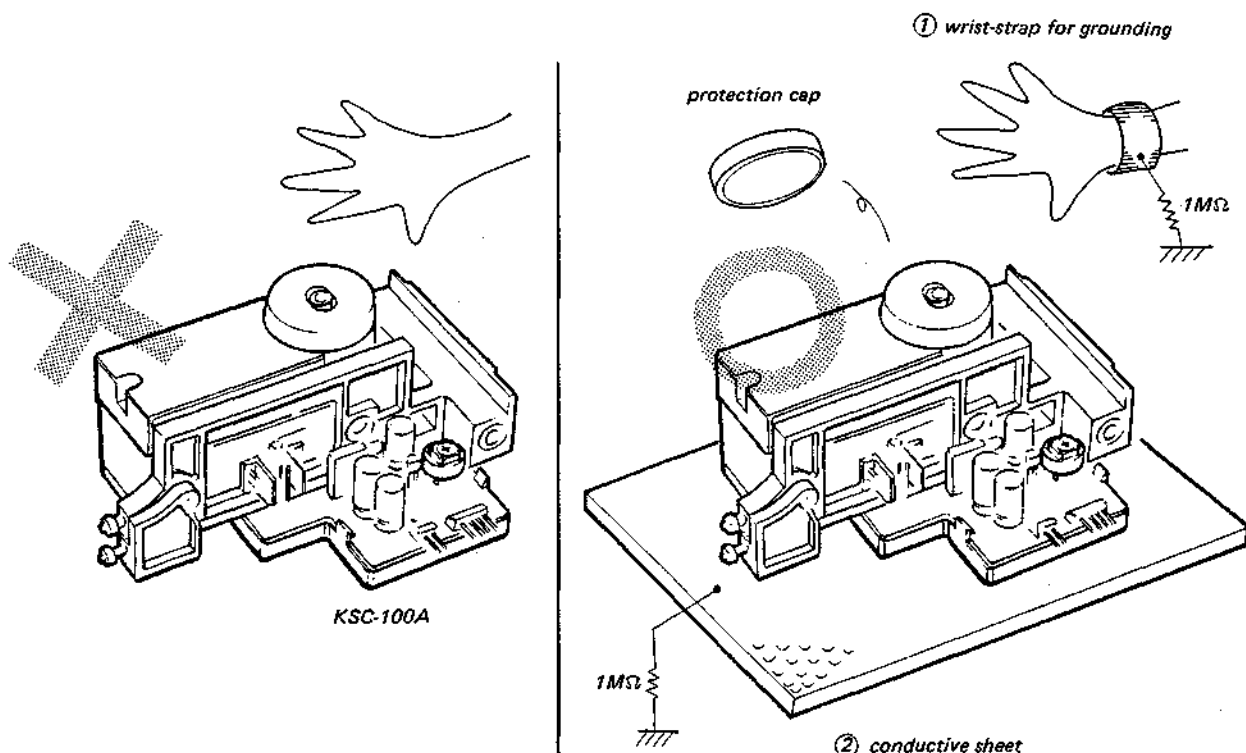

— SERVICING NOTE —

NOTES ON LASER DIODE EMISSION CHECK

The laser beam on this model is concentrated so as to be focused on the disc reflective surface by the objective lens in the optical pick-up block. Therefore, when checking the laser diode emission, observe from more than 30 cm away from the objective lens.

LASER DIODE CHECK

1. Ground servo amp board IC707 pin ③ (LD ON).
2. Observe the objective lens and confirm that the laser diode is emitting light.

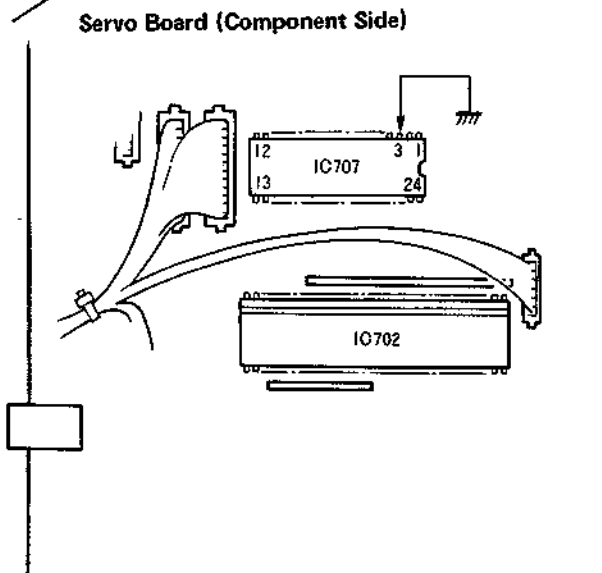
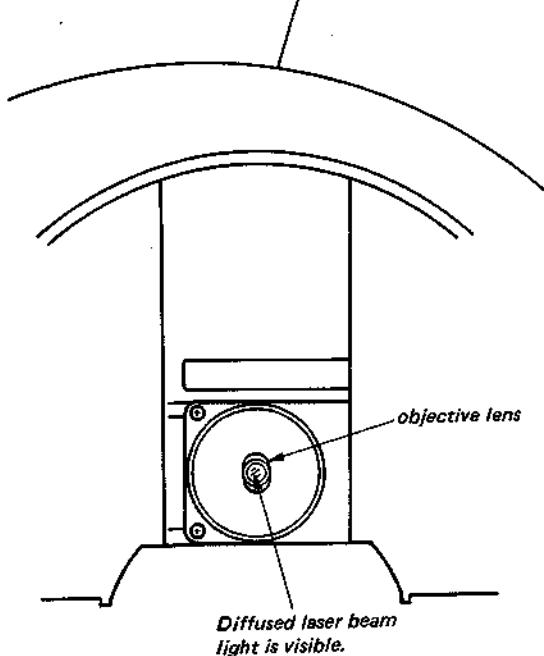
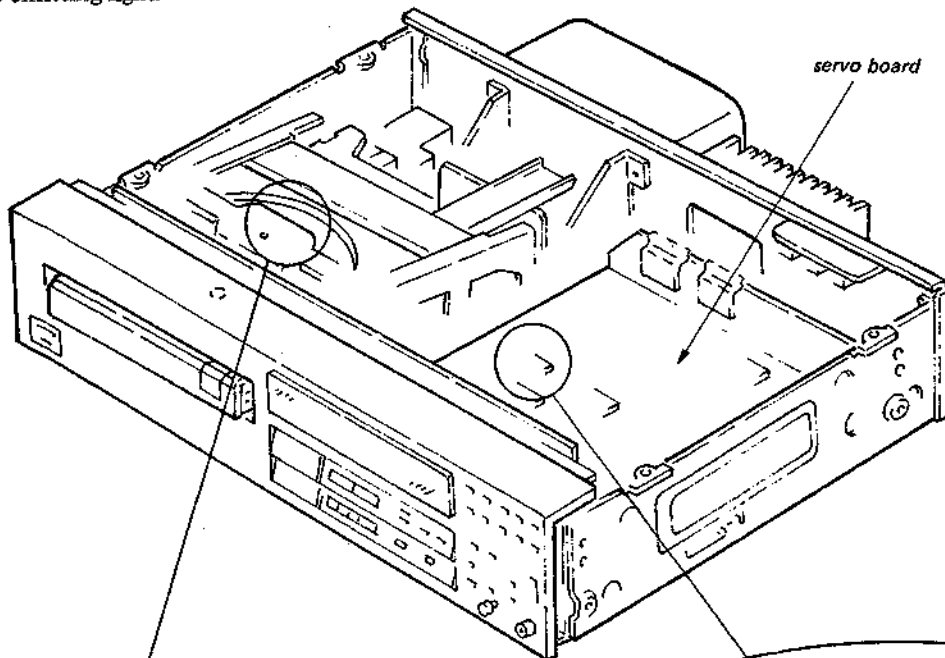

FOCUS SEARCH OPERATION CHECK

1. Block the disc detection phototransistor so that light does not hit it.

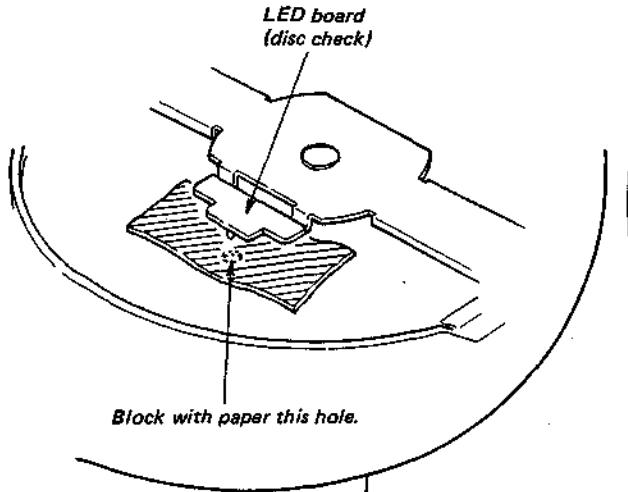

3. Observe the objective lens and confirm the operations below.

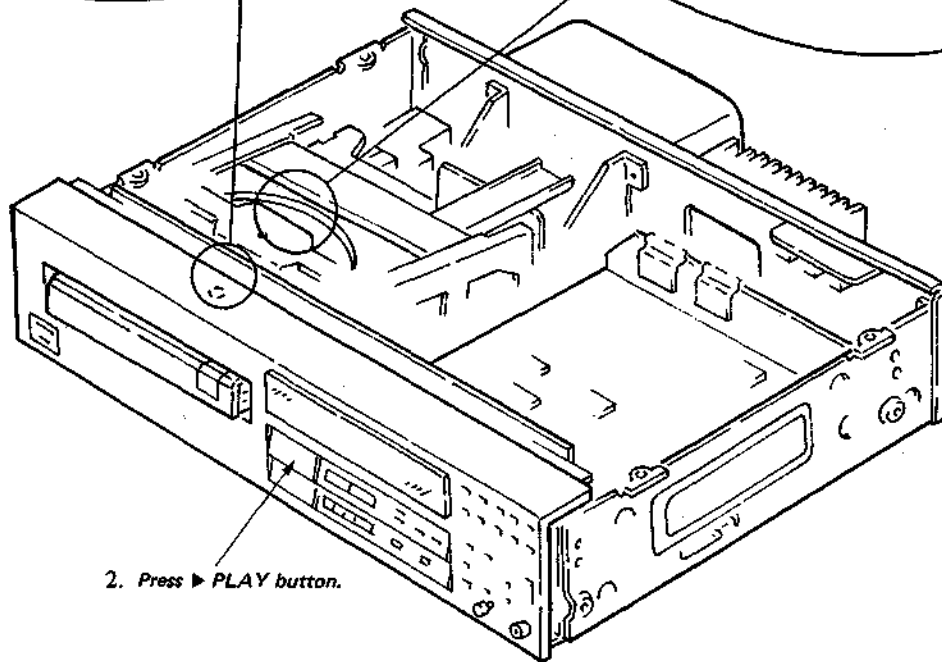
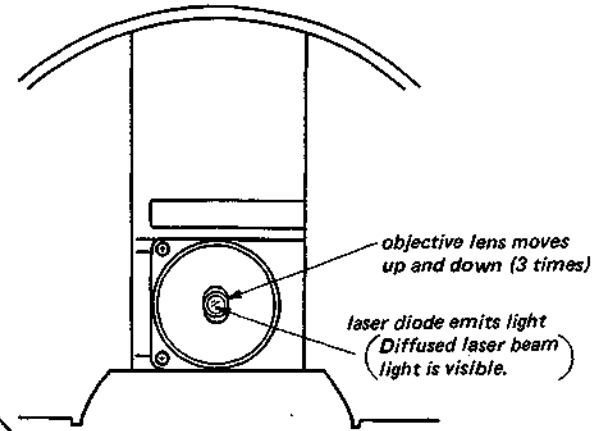
**NOTES ON REMOVING BOTTOM PLATE**

When placing the set level with the bottom plate removed, place on four corner supports.

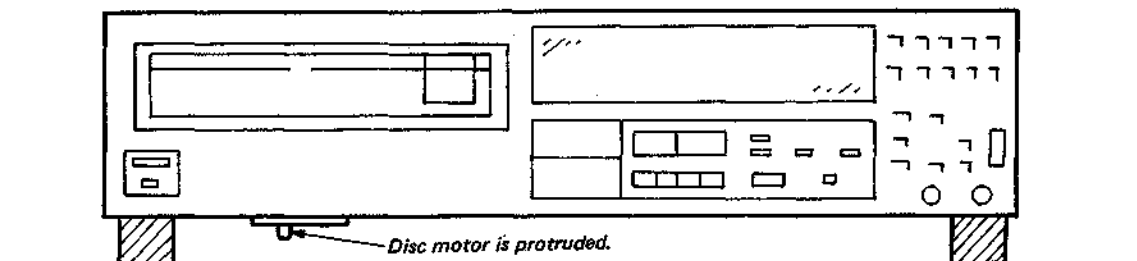

REPAIR METHOD FOR HYBRID CIRCUIT BLOCK

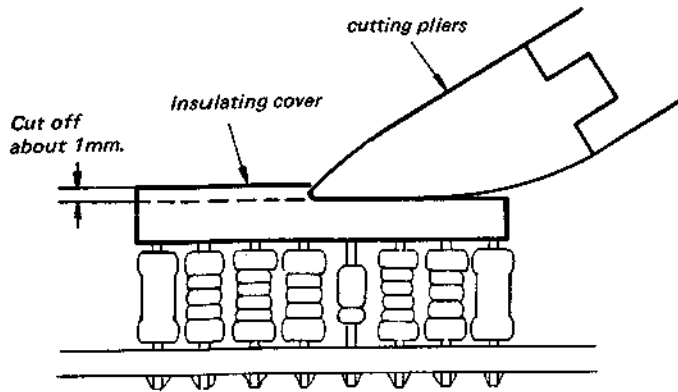

Using a cutting pliers, cut off the upper portion of the insulating cover about 1mm, exposing the top of the connecting brackets.

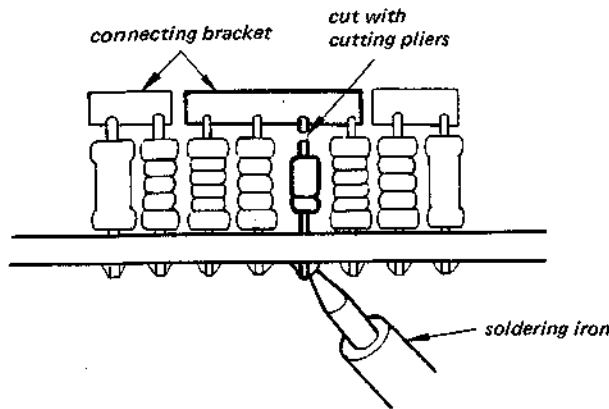
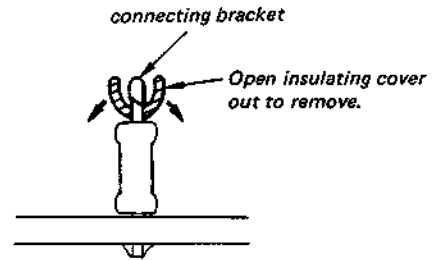

Cut off the lead of the defective part with cutting pliers. Remove solder and take out the defective part.

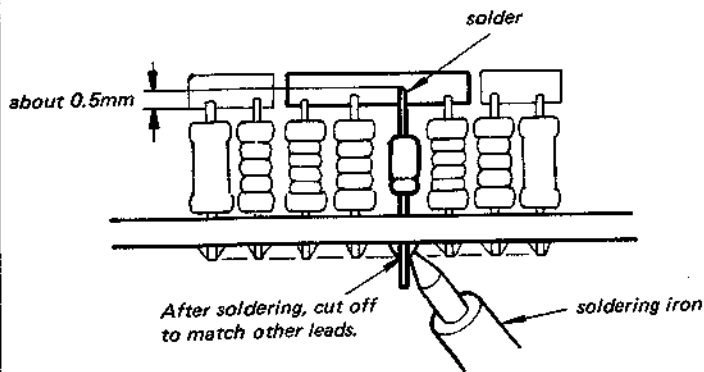

Insert the new part on the board and solder the lead to the board. Cut off the lead on the connecting bracket side so that it overlaps by about 0.5mm, and solder to the connecting bracket.

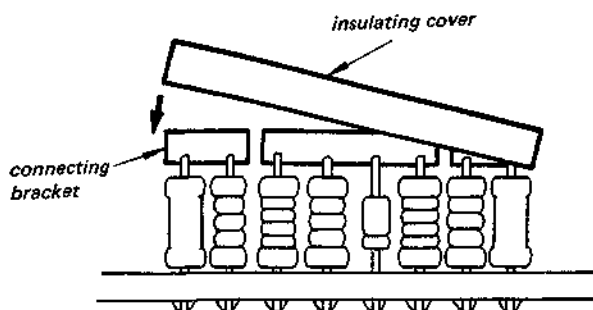

Open the insulating cover groove about 0.7mm and place over the connecting brackets, positioning one end first.

Insulating Cover
Part No.:

	3-677-012-01	3-677-012-11
A	3.4mm	2.2mm
B	2.6mm	1.8mm

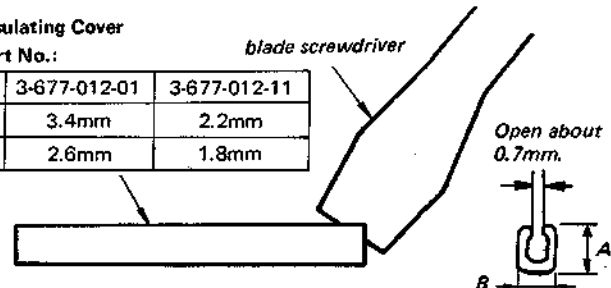

NOTES ON IC, TRANSISTOR REPLACEMENT

- When replacing T201, cut the centre lead, as shown in the illustration below. Be careful to the mounting direction of T201.

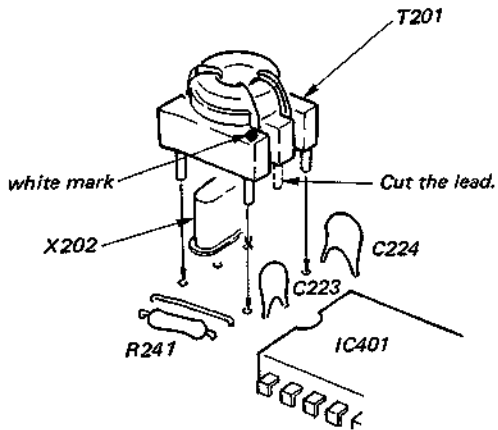

- When replacing IC302, 351, 402, 451, first clean the IC head and the inside of the heat sink with alcohol, then mount the heat sink and fill the heat sink indented portion with an epoxy type adhesive*, as shown in the illustration below.

* Epoxy type adhesive: Sony bond SC1000 or other quick drying 2 liquid compound.

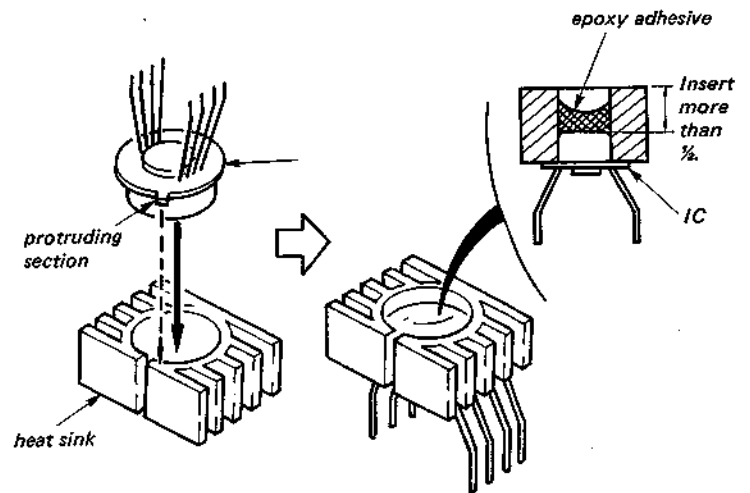

- When replacing IC901, 951, secure them so that leads of IC do not touch dip heat sink (upper, lower) by quick set adhesive.

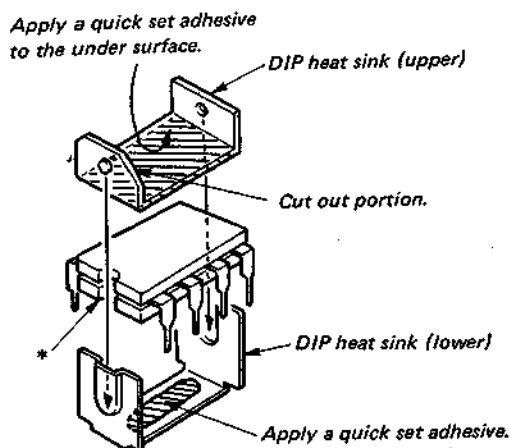

Assemble by matching up the section of the IC marked * and the cut-out portion of the DIP heat sink (upper).

SECTION 1 OUTLINE

1-1. PC BOARD LOCATION

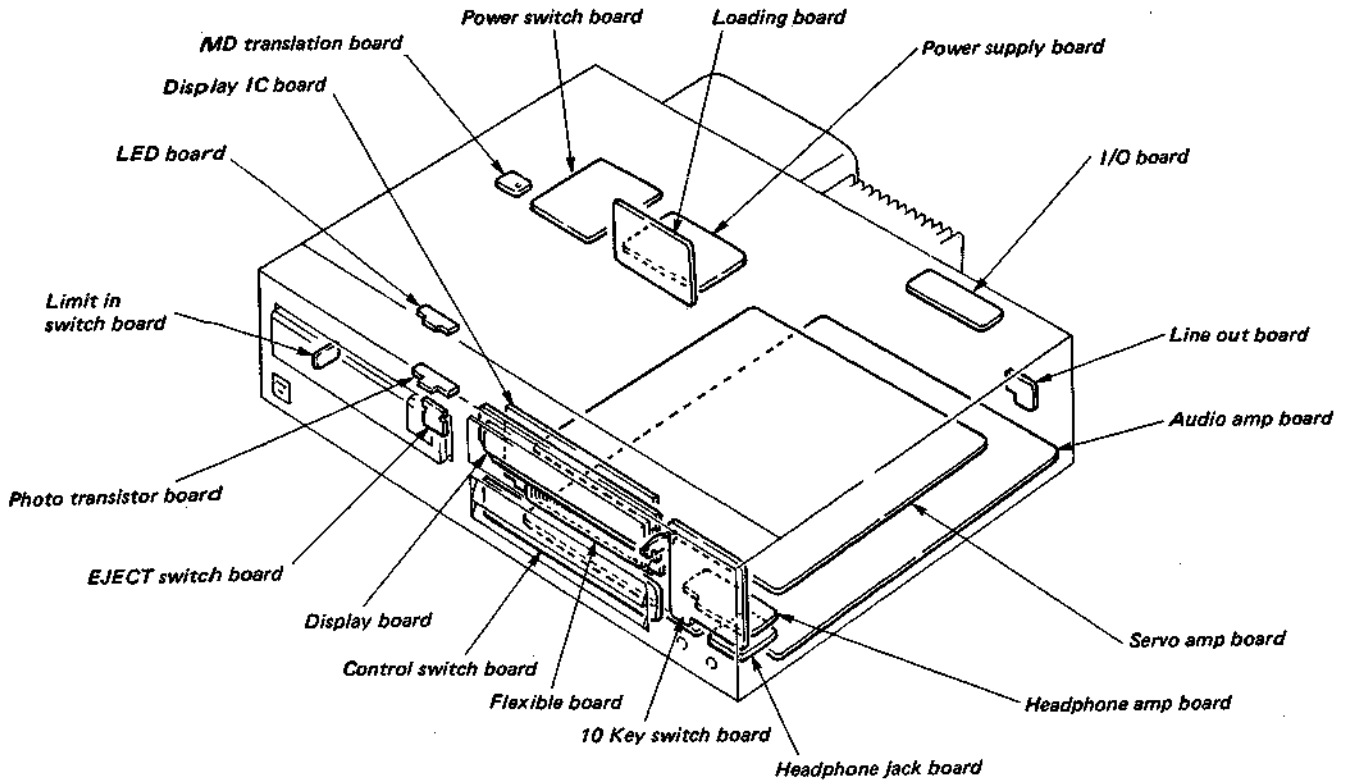

1-2. PHOTOGRAPH OF MECHANISM

● With top plate removed

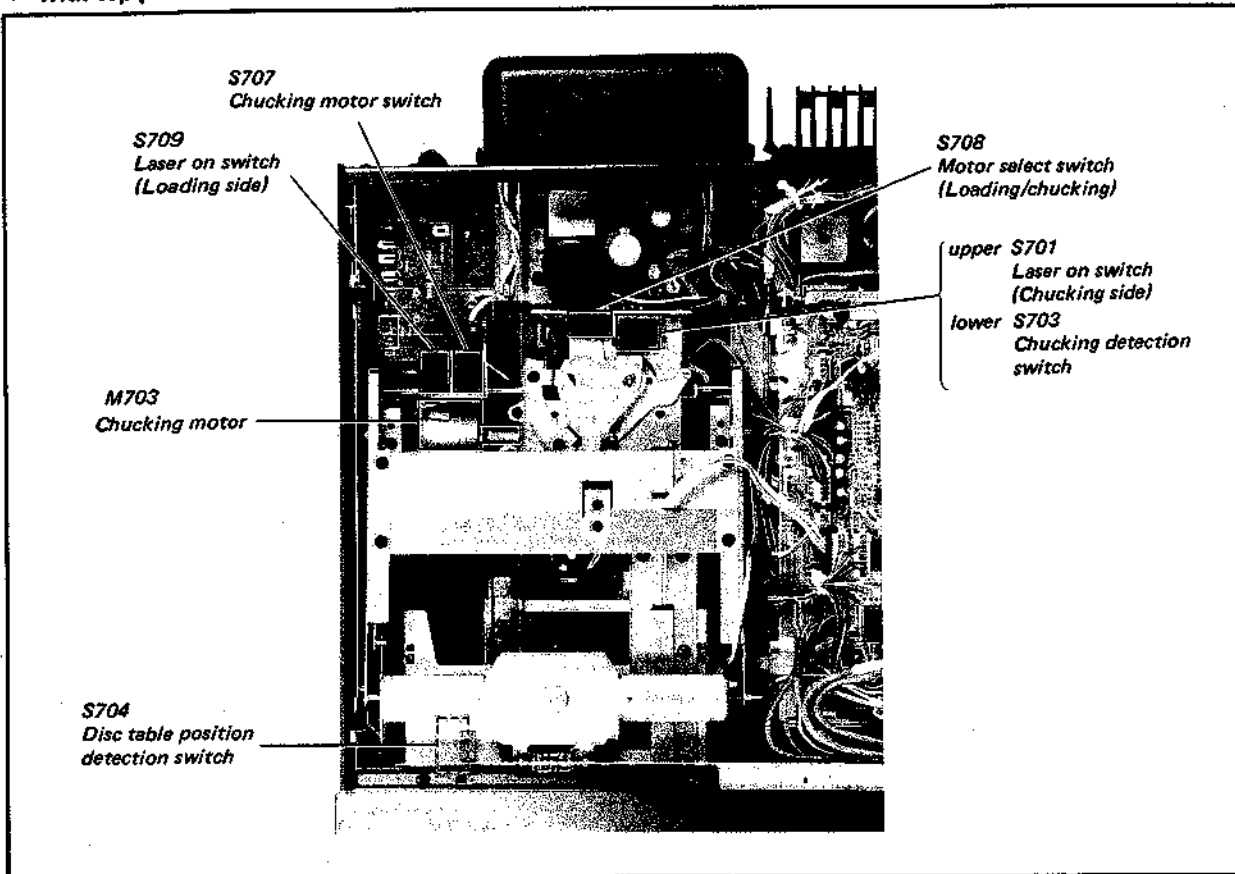

- With bottom plate removed

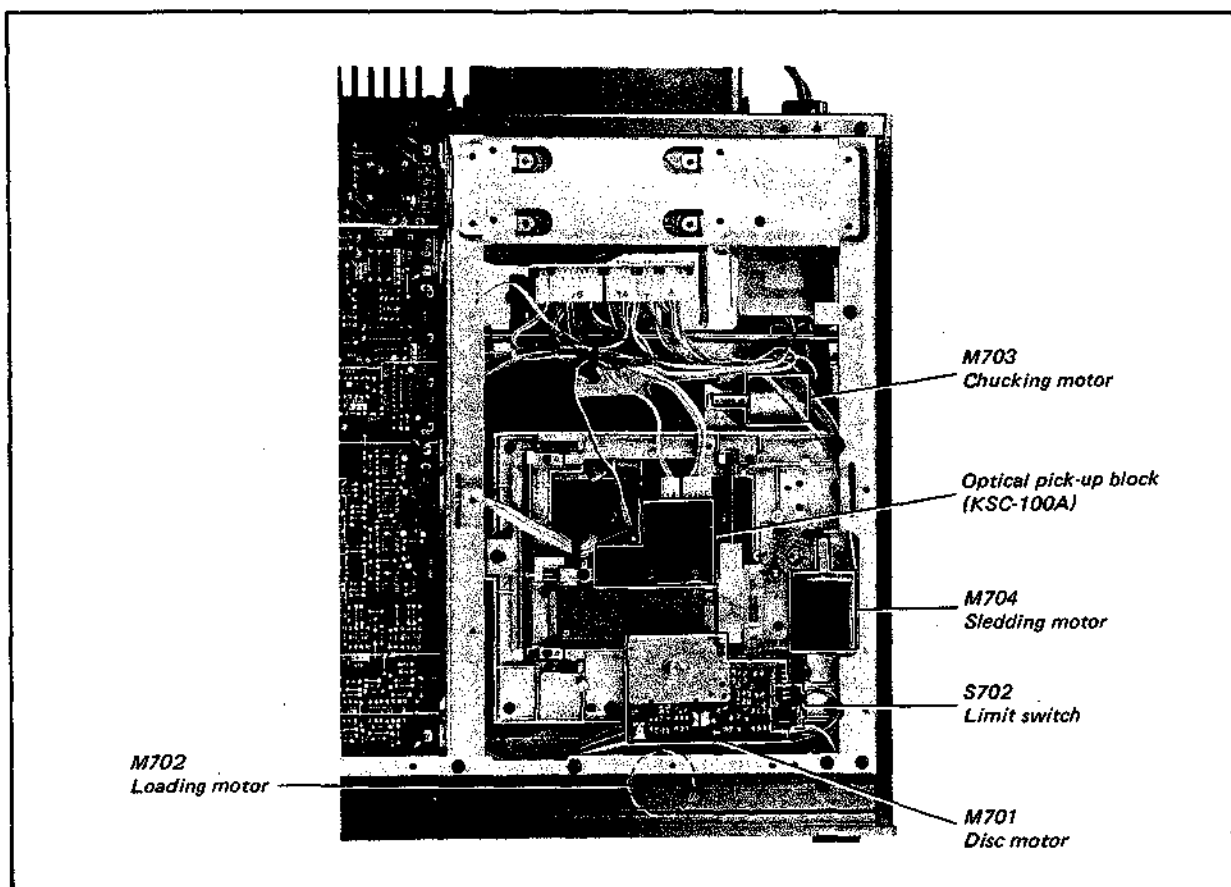

1-3. PRECAUTIONS

On safety

- Check that the operating voltage of your unit is identical with the voltage of your local power supply.
- Should any liquid or solid object fall into the cabinet, unplug the unit and have it checked by qualified personnel before operating it any further.
- Unplug the unit from the wall outlet if it is not to be used for an extended period of time. To disconnect the cord, pull it out by grasping the plug. Never pull the cord itself.

On installation

- Do not install the unit in a location near heat sources such as radiators or air ducts, or in a place subject to direct sunlight, excessive dust, mechanical vibration or shock.
- Good air circulation is essential to prevent internal heat build-up in the unit. Place the unit in a location with adequate air circulation. Do not place the unit on a soft surface, such as a rug that would block the ventilation holes on the bottom.

On operation

When the unit is not used, turn the power off, to conserve energy and to extend the useful life of your unit.

On cleaning the cabinet

Clean the cabinet, panel and controls with a soft cloth lightly moistened with mild detergent solution. Do not use any type of abrasive pad, scouring powder or solvent such as alcohol or benzine.

On repacking

Do not throw away the carton and the packing material. They make an ideal container to transport the unit in. When shipping the unit for repair work or to another location, repack it as illustrated on the carton box.

1-4. NOTES ON MOISTURE CONDENSATION

If the player is brought directly from a cold to a warm location, or is placed in a very damp room, moisture may condense on the lenses inside the unit.

Should this occur, the player will not operate. In this case, remove the disc and leave the player turned on for about an hour to evaporate the moisture.

1-5. NOTES ON COMPACT DISCS

Handle the disc by its edge, and to keep the disc clean, do not touch the rainbow colored surface.



Do not stick paper or tape on the labeled surface.

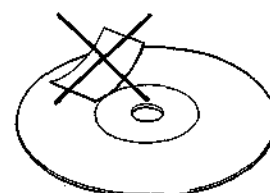

CDP-701ES

Do not expose the disc to direct sunlight or heat sources such as hot air ducts, or leave it in a car parked in direct sunlight where there can be a considerable rise in the temperature.

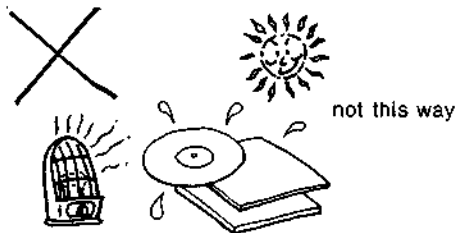

Before playing, clean the disc with the supplied cleaning cloth.

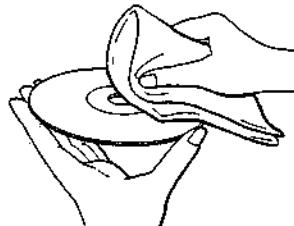

Do not use solvents such as benzene, thinner, commercially available cleaners or anti-static spray intended for analog discs.

After playing, store the disc in its case.

1-6. CONNECTIONS

- Turn off the amplifier before making connections.
- Be sure to insert the cable connectors firmly into the jacks. Loose connections may cause hum and noise.
- Connect the red plug of the supplied connecting cord to the right-channel jack [R] of the amplifier and the white plug to the left-channel jack [L]. Otherwise, the right and left channels will be reversed.
- Leave a little slack in the connecting cord to allow for inadvertent shock or vibration.

- Be sure not to connect the CD player to the PHONO input jacks of the amplifier.
- If the CD player causes interference to radio and television reception, turn off the player or move the player away from the receiver.

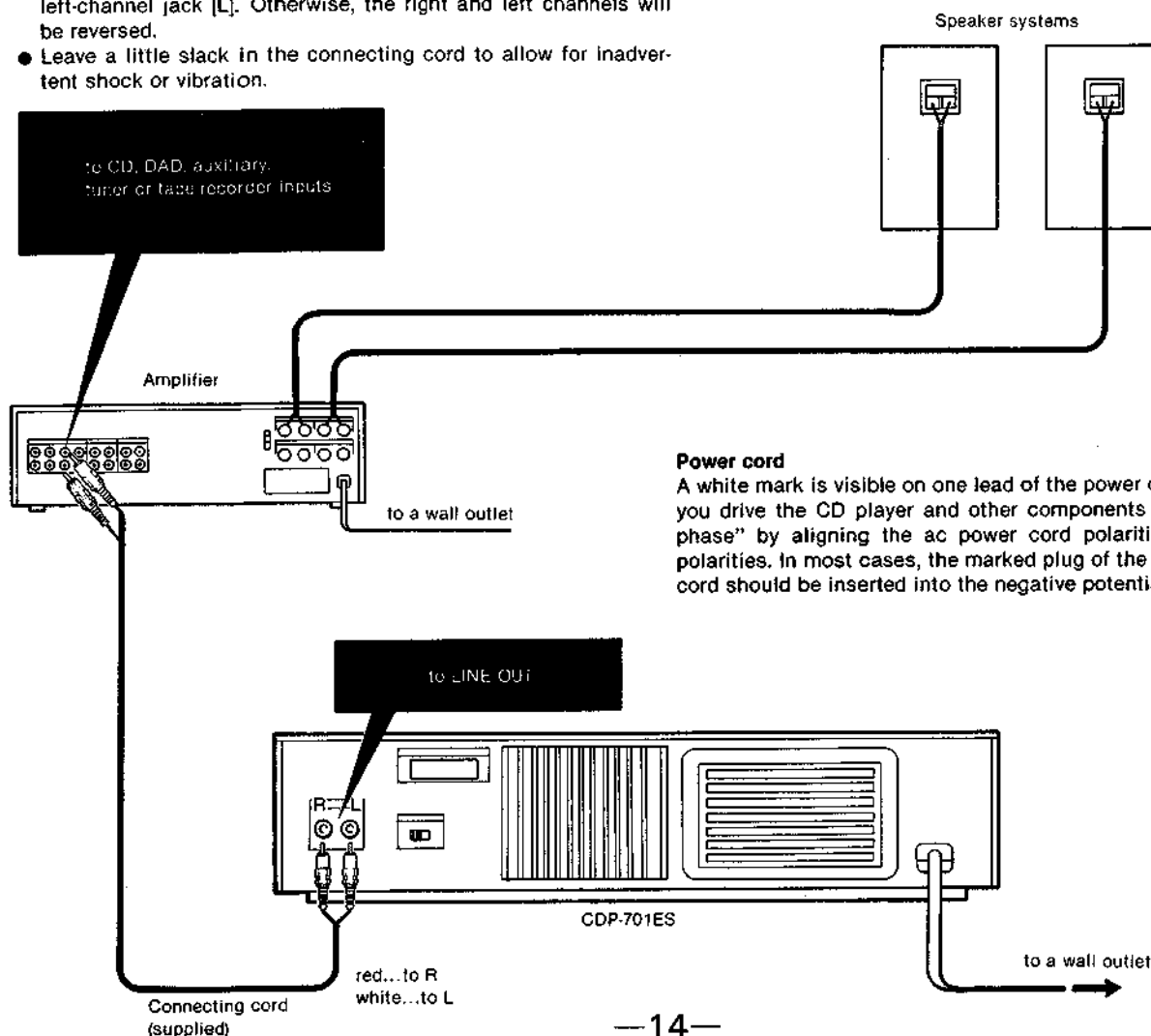

1-7. LOCATION AND FUNCTION OF CONTROLS

Before plugging in or attempting to operate this unit, it is suggested that you familiarize yourself with all its switches and controls and the purpose of each. Each number in the photo is keyed to the descriptive text.

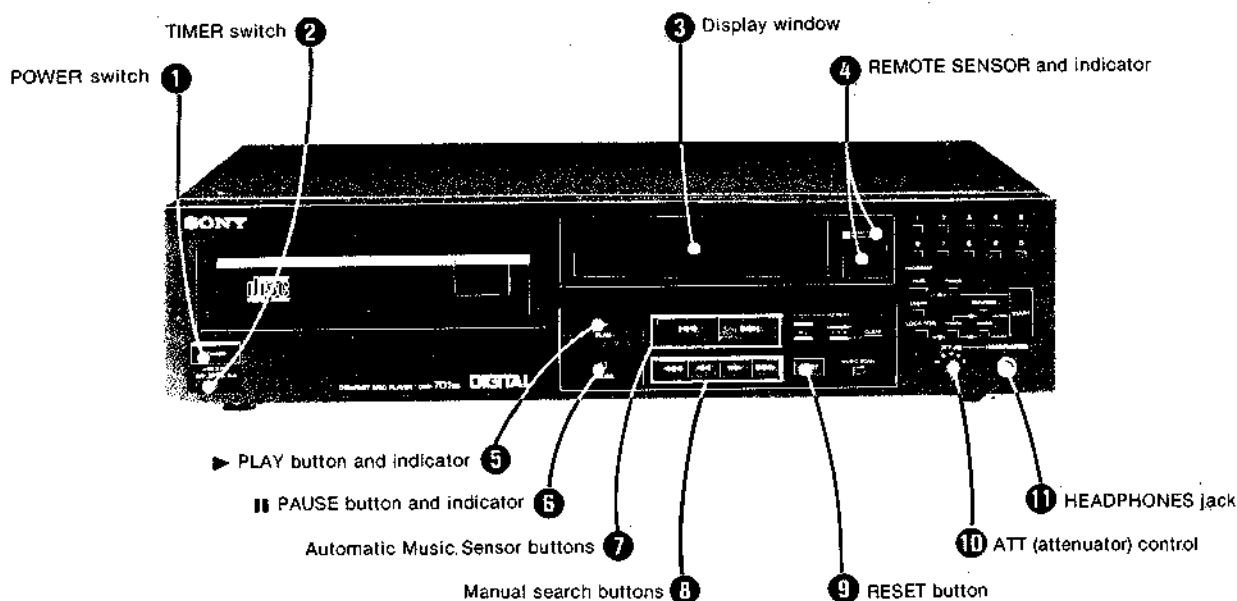

1 POWER switch

Depress to turn on the power (ON). The "1" indicator will appear in the display window in a few seconds. To turn the power off, press the switch again (OFF).

2 TIMER switch

You can set the player to play a disc at a predetermined time by connecting any commercially available timer. To play, set this switch to PLAY. See "Timer-activated play" on page 24.

3 Display window

See page 17.

4 REMOTE SENSOR and indicator (for remote control)

The infrared beam transmitted by the supplied Remote Commander is received here. The indicator blinks to indicate that a function key of the Remote Commander has been pressed.

5 ▶ PLAY button and indicator

Press to start normal disc play. The built-in ▶ indicator will illuminate.

6 || PAUSE button and indicator

Press to pause during play. The built-in || indicator will illuminate. To release the pause mode, press this button again. The indicator will go off and disc play will resume.

7 Automatic Music Sensor buttons

◀◀ (back selection) button: Press to go back to a previous selection.

▶▶ (forward selection) button: Press to skip ahead to a later selection.

8 Manual search buttons

Keep holding the appropriate button down to search for a particular point on the disc during either play or pause.

You can monitor the disc sound reproduced in forward or in reverse at a high speed while searching during play.

When you release this button, normal-speed play will resume (during play) or the player will return to the pause mode (during pause).

◀◀ button: To go backwards at a high speed (several times higher than the normal playing speed).

◀◀◀ button: To go backwards at a higher speed than the ◀◀ button.

▶▶ button: To skip ahead at a high speed (several times higher than the normal playing speed).

▶▶▶ button: To skip ahead at a higher speed than the ▶▶ button.

9 RESET button

When this button is pressed, disc play is reset to the very beginning of the first selection and the player stands by.

10 ATT (attenuator) control

This control adjusts the volume at the headphones. At the minimum position, the sound is just audible.

11 HEADPHONES jack (stereo phone jack)

Accepts any low or high impedance stereo headphones.

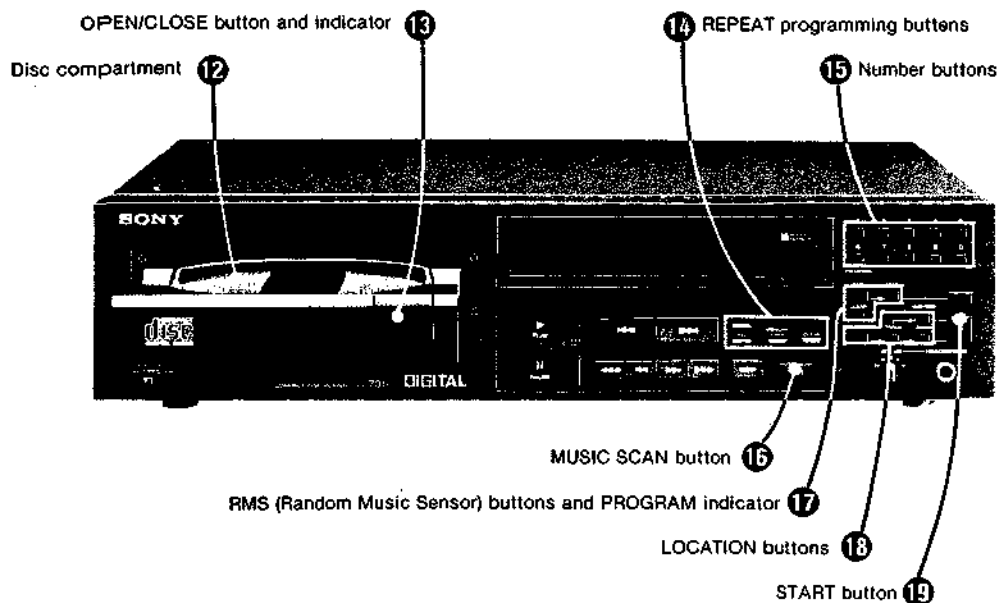

12 Disc compartment

Place a compact disc here.

13 OPEN/CLOSE button and indicator

With one touch of this button the disc compartment opens for disc loading. The indicator on the OPEN/CLOSE button will illuminate while the compartment is opening. With another touch the compartment closes.

14 REPEAT programming buttons

Press these buttons to program repeat play of the disc.

1 button: To repeat the selection now being played.

To release repeat play, press the button again.

ALL button: To repeat all the selections on the disc.

To release repeat play, press the button again.

MEMORY A→B button: To repeat play between specific points on the disc.

With one touch of this button the built-in indicator flickers and the point where the button has been pressed is memorized as the "A" (start) point of repeat play.

With another touch, the built-in indicator illuminates steadily and the point where the button has been pressed a second time is memorized as the "B" (end) point of repeat play.

When the **CLEAR** button is pressed, this repeat play will be cancelled.

Any repeat program is also cancelled when another REPEAT programming button is pressed.

15 Number buttons

Used for programming RMS play and the LOCATION function.

See page 21 and 22.

16 MUSIC SCAN button

Press this button when you want to scan the first 10 seconds of all the selections on the disc in sequence. See page 20.

17 RMS (Random Music Sensor) buttons and PROGRAM indicator

Used to select the selections you want to play and program their sequence. Up to 8 selections can be played in any desired sequence. See page 21.

18 LOCATION buttons

Used to program the point on the disc at which you want play to start. See page 22.

19 START button

After programming RMS play or the LOCATION function, press this button to start play.

Display window

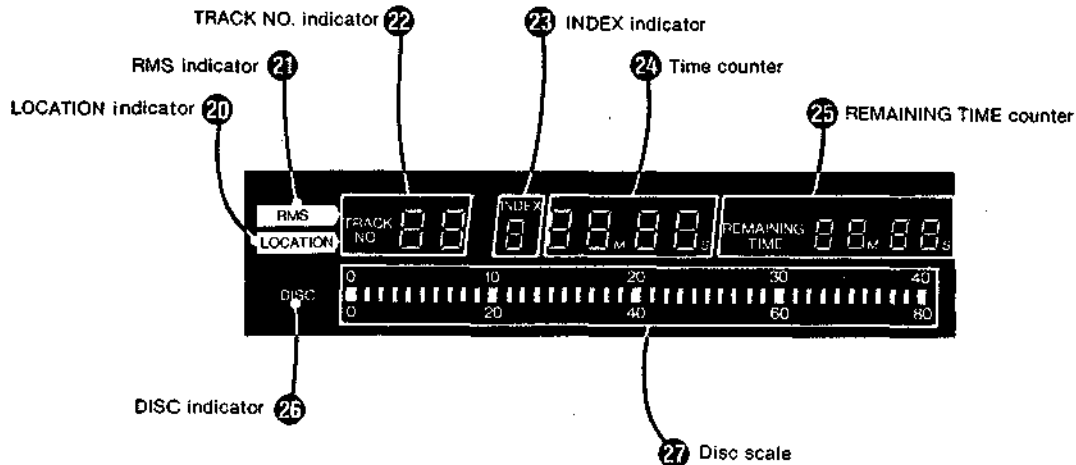

⑳ LOCATION indicator

This indicator lights up when the LOCATION button is pressed.

㉑ RMS Indicator

This indicator flickers when the RMS button is pressed and illuminates steadily during RMS play.

㉒ TRACK NO. indicator

This indicator shows the track number of the selection being played. When the LOCATION button is pressed, or while the music scan function is working, this indicator flickers.

㉓ INDEX indicator

If index signals are recorded on the disc to allow significant parts of a program to be easily located, the index numbers are shown here.

㉔ Time counter

This time counter shows the location in a particular selection by means of actual elapsed time. The first two digits of the counter show playing time of the selection in minutes (M), and the last two digits show the seconds (S).*

*If you press the ►► or ►►► button at the end of the disc, the time counter will change to "--M--S" indicating that the end of the last selection has been reached. To return to a previous display, press the ◀◀, ◀◀◀ or ◀◀◀◀ button. If you press the ◀◀ or ◀◀◀ button at the beginning of the disc, the time counter will change to "--M--S", indicating that the beginning of the first selection has been reached.

㉕ REMAINING TIME counter

This counter shows how much playing time is left on the disc in minutes (M) and seconds (S).

㉖ DISC Indicator

The indicator flickers when the disc compartment is moving. When the disc compartment has closed with a disc in place (in the standby mode), and during disc playing, the indicator illuminates steadily.

㉗ Disc scale

When the disc's playing time is less than 40 minutes, the full scale represents 40 minutes. When the playing time is more than 40 minutes, the scale represents 80 minutes.

The point on the disc that is playing is indicated on the scale by a flickering light. The parts of the scale that are brightly lit indicate the beginning of the selections.

CDP-701ES

Rear panel

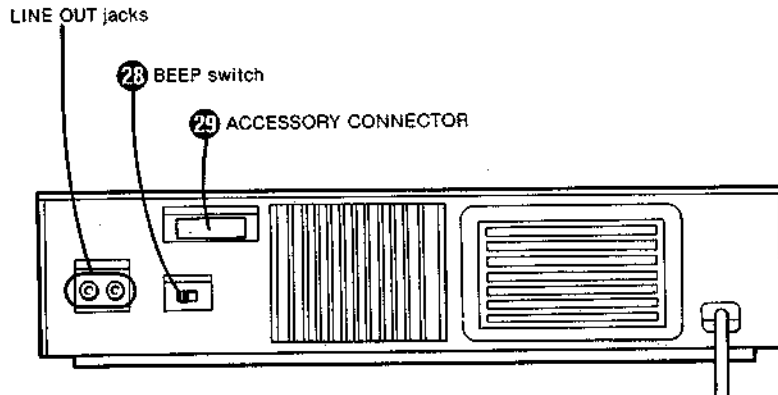

28 BEEP (buzzer) switch

Set to ON to have a signal tone sounded when a signal from the supplied Remote Commander is received. Set the switch to OFF when a signal tone is not necessary.

29 ACCESSORY CONNECTOR

Used to extend the utility of this compact disc player by providing for the connection of optional equipment which will be available in the future.

Do not remove the cover except when connecting any equipment to this connector.

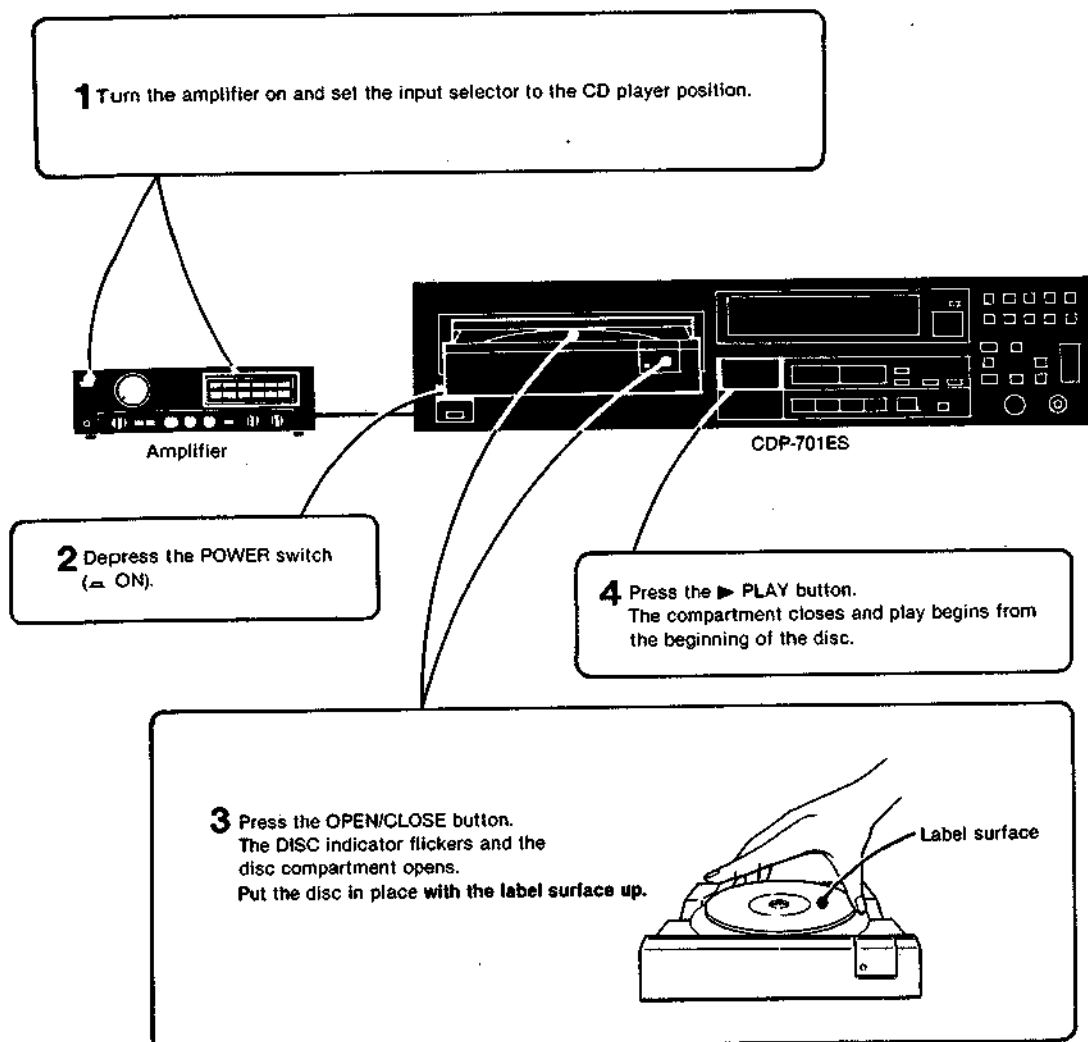
1-8. DISC PLAYING**TO PLAY**

If you press the ►| button to select the desired selection with the compartment opened, then press the ► PLAY button, the compartment will close and play will begin from that selection.

If you press the || PAUSE button when the compartment is open, the compartment will close and the disc will pause at the beginning of the first selection.

When the player reaches the end of the last selection of the disc, it is automatically reset to the beginning of the disc and stands by. To open the compartment, press the OPEN/CLOSE button.

An important point to remember

In the CD system, a wider dynamic range is achieved than that of the conventional analog system, and the peaks of high level inputs are recorded with high-fidelity. In addition, the noise level is very low.

If you turn up the volume inadvertently while listening to a portion where no audio signals or very low level inputs are recorded, the speakers may be damaged when the portion with peak levels is played.

TO STOP DURING PLAY**To open the compartment**

Press the OPEN/CLOSE button. The disc will stop rotating and the compartment will open.

To pause for a moment during play

Press the || PAUSE button. The || indicator will illuminate.

To release pause and restart play from the same point, press the || PAUSE button again.

To reset to the beginning of the first selection

Press the RESET button. The player will stand by.

1-9. SEARCH OPERATION

TO SEARCH FOR A PARTICULAR SELECTION—AMS (Automatic Music Sensor) function

Using the ◀◀ or ▶▶ button, you can quickly locate a desired selection ahead or back. When the button is pressed, the player searches the selection data recorded at the beginning of each selection and play will start from the beginning of the selection.

To search for a back selection

Press the ◀◀ button during play or pause.

When the ◀◀ button is pressed once, the beginning of the selection being played is searched for. Each time the button is pressed, one selection back is searched for.

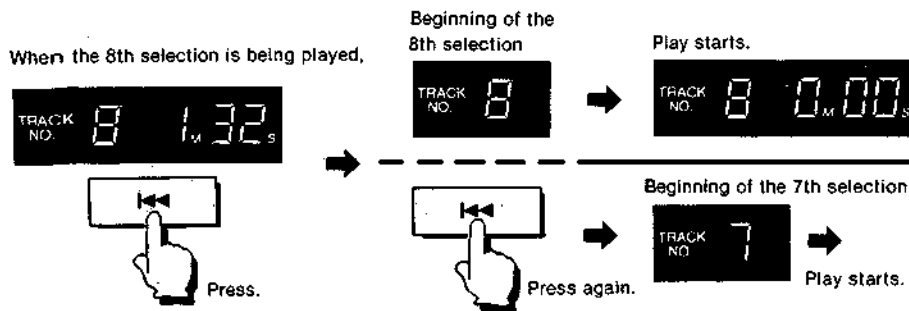

Press the ◀◀ button repeatedly until the desired music number is displayed.

If you press the ◀◀ button after the first selection is located, the TRACK NO. indicator will not change.

To search for a selection ahead

Press the ▶▶ button during play or pause.

When the ▶▶ button is pressed once, the next selection after that being played is searched for. Each time the button is pressed, the selection ahead is searched for.

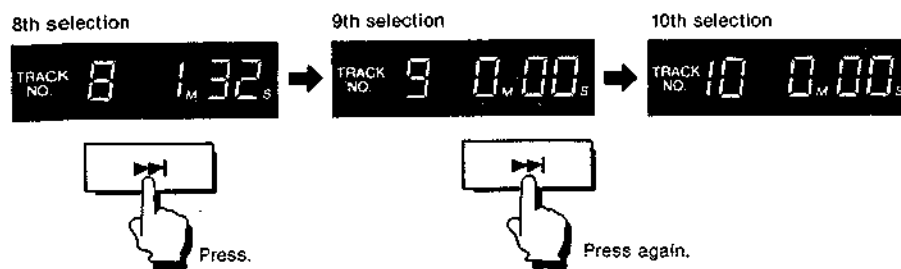

If you press the ▶▶ button after the last selection is located, the TRACK NO. display will not change.

TO SEARCH FOR A PARTICULAR POINT IN A SELECTION

—Manual Search

Using the manual search buttons, you can locate a particular point of a selection during play or pause. While one of the manual search buttons is held down, the disc playing goes ahead or back. Release the button at the desired point found by observing the time counter or monitoring the high-speed sound (only during play).

Manual search buttons

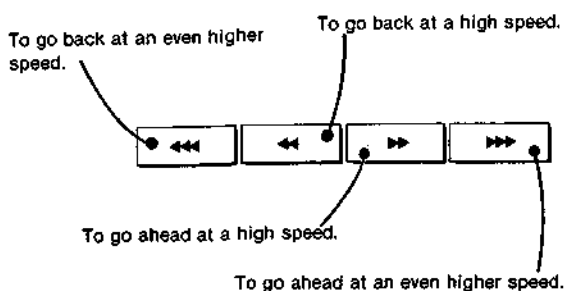

MUSIC SCAN

When the MUSIC SCAN button is pressed, the first 10 seconds of all the selections on the disc will be played in sequence. When you have found the selection you want, press the ▶ PLAY button. The MUSIC SCAN function will be cancelled and normal playback will begin.

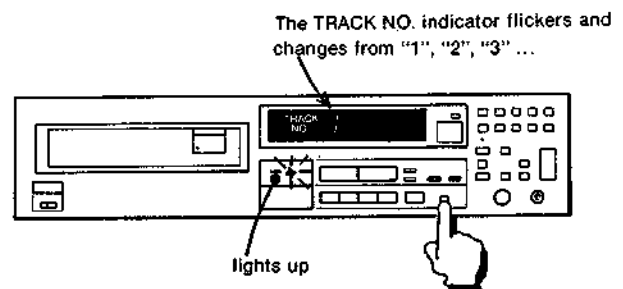

1-10. RMS (RANDOM MUSIC SENSOR) PLAY

You can select up to 8 selections on a disc and play them in whatever sequence you wish.

During RMS play, the REMAINING TIME counter shows the remaining playing time to the end of the last-programmed selection. On the disc scale, only the programmed selections are dimly lit.

If you wish to skip to the next-programmed selection or go back to the previous selection programmed, press the **▶▶** button or the **◀◀** button respectively.

1 Press the RMS button.

2 While the RMS indicator is lit, press the number button corresponding to the selection which you want to play first.

3 Press the TRACK button. The PROGRAM indicator lights up and the selection is programmed.

4 Repeat steps 2 and 3. The selections are programmed in the order in which the number buttons are pressed. The TRACK NO. indicator in the display window changes from "-1", "-2", "-3" ..., each time a selection is programmed. Up to 8 selections can be programmed until the "E" is displayed. "E" is displayed when an incorrect selection number is input.

5 After programming the selections, press the START button. The ▶ indicator lights up and RMS play begins. The programmed selections will be played in the programmed sequence.

To stop RMS play
Press the RMS CLEAR button. The PROGRAM indicator goes out and the whole RMS program is cancelled. It is not possible to cancel a particular selection. To change part of the program, first press the RMS CLEAR button and resume programming.

To play a selection that has not been programmed

Press the **▶** PLAY button. The RMS play will be cancelled temporarily and any selection on a disc can be played. When you wish to restart the RMS play, press the START button. Play will start from the first-programmed selection.

● While the PROGRAM indicator is lit, the RMS program is held in the memory.

To repeat the RMS play

To repeat the selection being played, press the REPEAT 1 button. To repeat all the programmed selections, press the REPEAT ALL button.

The REPEAT A ↔ B button does not function during RMS play.

During REPEAT ALL play and REPEAT 1 play, the REMAINING TIME counter is not displayed. It will appear after the **▶** PLAY button has been pressed to cancel repeat play and the START button is pressed.

To add to the programmed sequence

After RMS play has started, you can add further selections to the sequence until the total number of programmed selections reaches eight.

- 1 Press the **▶** PLAY button. (The RMS indicator goes out.)
- 2 Press the RMS button. (The RMS indicator flickers.)
- 3 Press the number button(s) of the selection you want to include, then press the TRACK button. (The TRACK NO. indicator shows how many selections are programmed.)
- 4 Press the START button. Play will start from the first-programmed selection and will continue with the selections you have just added.

Important points to remember

If the programmed selections do not play as desired, check that :

- An incorrect number button has been pressed.
- The number button has not been pressed while the RMS indicator was flickering. (The RMS indicator flickers for a short time and goes out automatically. To light up the indicator again, press the RMS button.)
- The **◀◀**, **◀◀◀**, **▶▶** or **▶▶▶** button has been pressed. (If any one of these buttons has been pressed, RMS play will be temporarily cancelled. To restart RMS play, press the START button.)

1-11. THE LOCATION FUNCTION

Using this player's LOCATION function, you can start play at a particular number of minutes and seconds from the beginning of any selection or at any Index number.

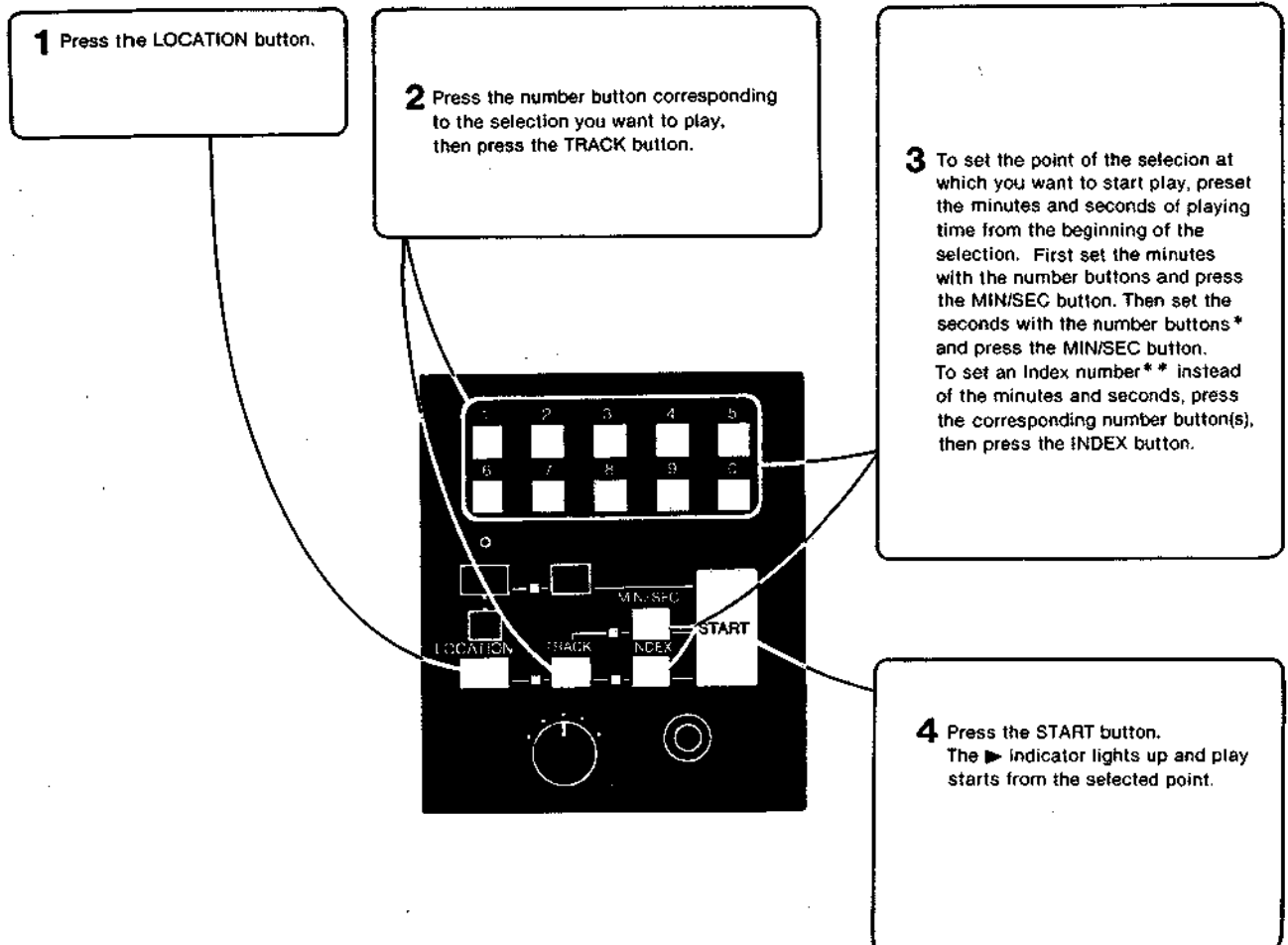

* To set 1 to 9 seconds, first press the "0" button, then the corresponding number button.

** If you have selected an Index number of 2 or more which is not recorded on the disc, play will start from the beginning of the chosen selection.

Important points to remember

If play does not start from the selected point, check that :

- The number button has been pressed after the LOCATION indicator has gone out. (The LOCATION indicator is lit for a short time and goes out automatically. To light up the indicator again, press the LOCATION button.)
- An Index number which is not recorded on the disc has been selected or a time exceeding the actual playing time has been selected. (In these cases, play will start from the beginning of the chosen selection.)
- The selected time corresponds to a blank space at the end of the selection. (Play may start from the beginning of that selection.)

1-12. REPEAT PLAY

Using the REPEAT programming buttons, you can repeat the selection being played, the whole disc, or particular portion of the disc.

TO REPEAT ONLY THE SELECTION BEING PLAYED

Press the **1** button during play. The built-in indicator will illuminate. When the disc reaches the end of the selection, it will automatically go back to the beginning of the selection and play will restart.

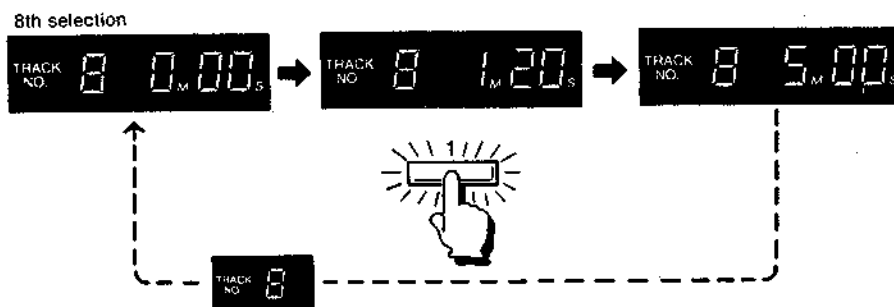

TO REPEAT THE WHOLE DISC

Press the **ALL** button. The built-in indicator will illuminate. When the disc reaches the end of the last selection, the player will automatically go back to the beginning of the first selection, and play will restart.

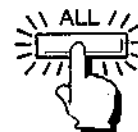

TO REPEAT BETWEEN PARTICULAR POINTS

- 1 When the disc plays the point from which you wish to start the repeat play (point A), press the **A ↔ B** button. The built-in indicator will start flickering showing the point A is memorized.
- 2 When the disc reaches the point at which you wish to stop the repeat play (point B), press the **A ↔ B** button again. The built-in indicator will then illuminate steadily showing the point B is memorized. The disc will go back to the point A and play will restart.

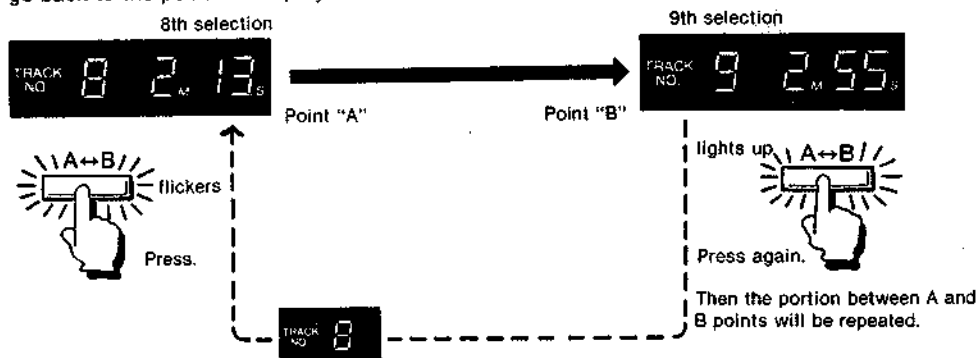

If the **▶** PLAY button is pressed during the **A ↔ B** repeat play, the disc will go back to the point A.

MORE ABOUT A ↔ B REPEAT FUNCTION

To play from a desired point (memory play)

- 1 At the point from which you wish to listen later (point A), press the **A ↔ B** button.
 - 2 When you press the **▶** PLAY button, the disc will go back to the point A and play will restart.
- To cancel the point A, press the **CLEAR** button.

To repeat the whole disc eliminating an unwanted portion (jump repeat)

- 1 At the point where you wish to end the portion to be eliminated (point A), press the **A ↔ B** button.
 - 2 Press the **◀◀**, **◀** or **◀◀◀** button to search for the point from which you wish to start eliminating (point B), and then press the **A ↔ B** button. The repeat play eliminating the **B — A** portion will start.
- To cancel, press the **CLEAR** button.

TO CANCEL THE REPEAT PLAY

The **1** or **ALL** repeat play continues until the button is pressed again.

To cancel the **A ↔ B** repeat play, press the **CLEAR** button.

Any repeat program is also cancelled when another REPEAT programming button or the **RESET** button is pressed.

1-13. TIMER-ACTIVATED PLAY

By connecting any of several commercially-available timers, you can play a disc at any desired time.

Example of power connection

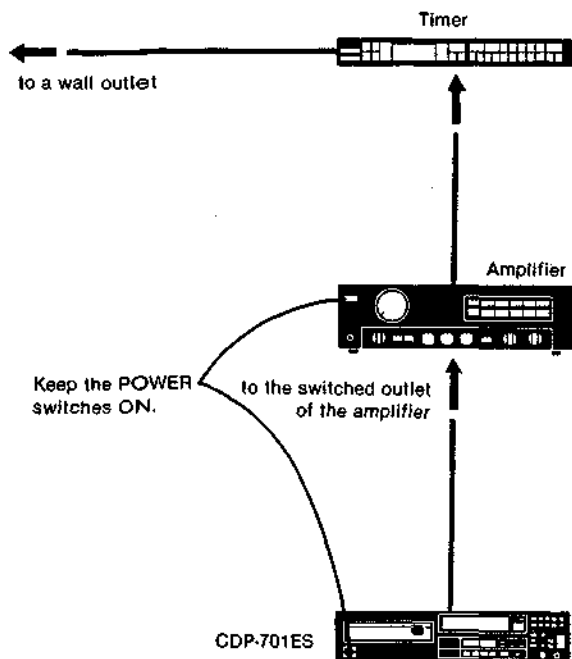

To play using a timer

- 1 Set the player's **TIMER** switch to **OFF**.
 - 2 Turn on the amplifier and set the appropriate switches for disc playing.
 - 3 Turn on the player and insert a disc.
 - 4 Set the timer for the desired time.
(At this point, power will be cut off.)
 - 5 Set the player's **TIMER** switch to **PLAY**.
- The player is now ready to start play of the first selection at the time set on the timer.

After the timer-activated play has been completed...
Be sure to set the **TIMER** switch of the player to **OFF**.

CDP-701ES CDP-701ES

1-14. BLOCK DIAGRAM

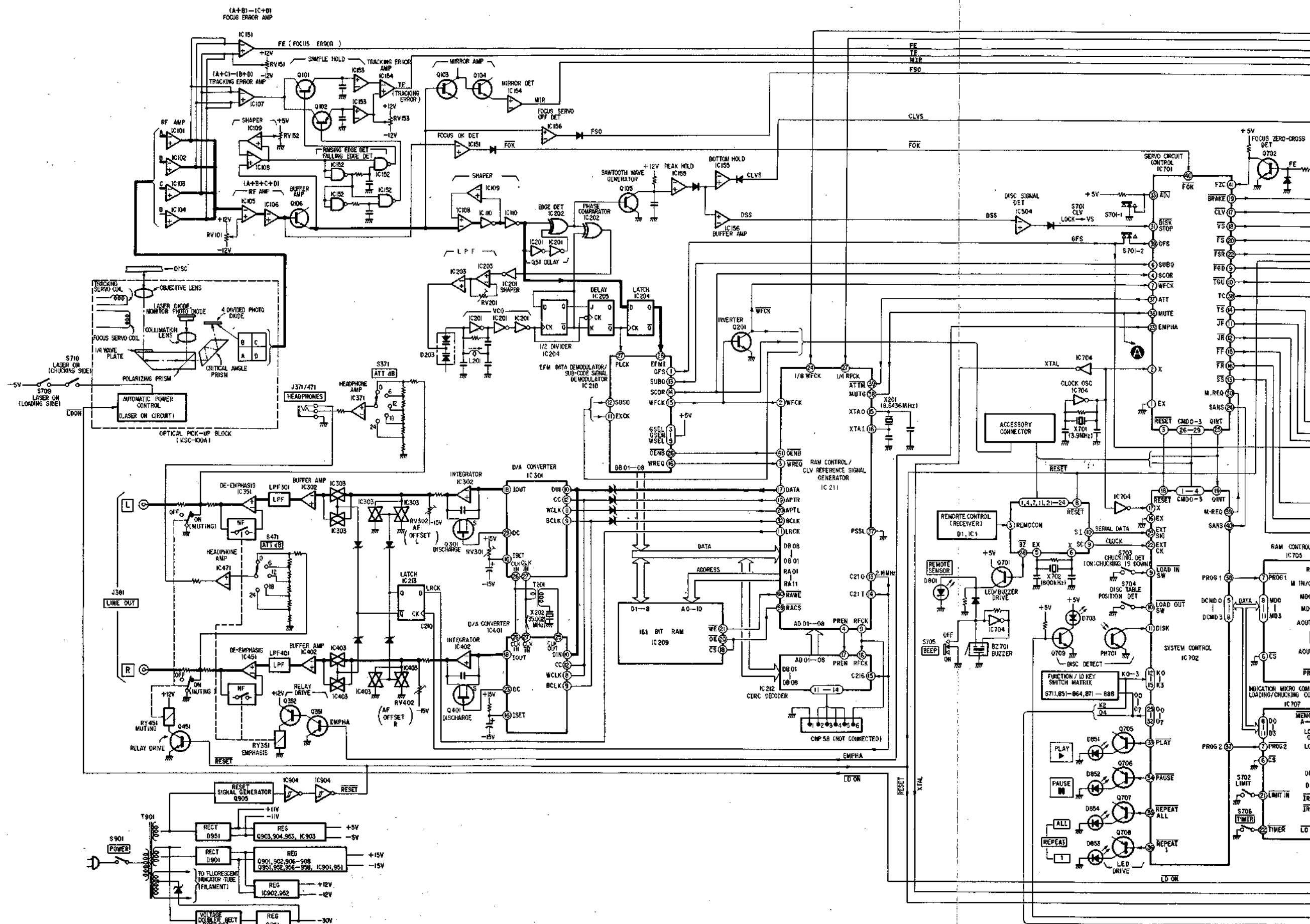

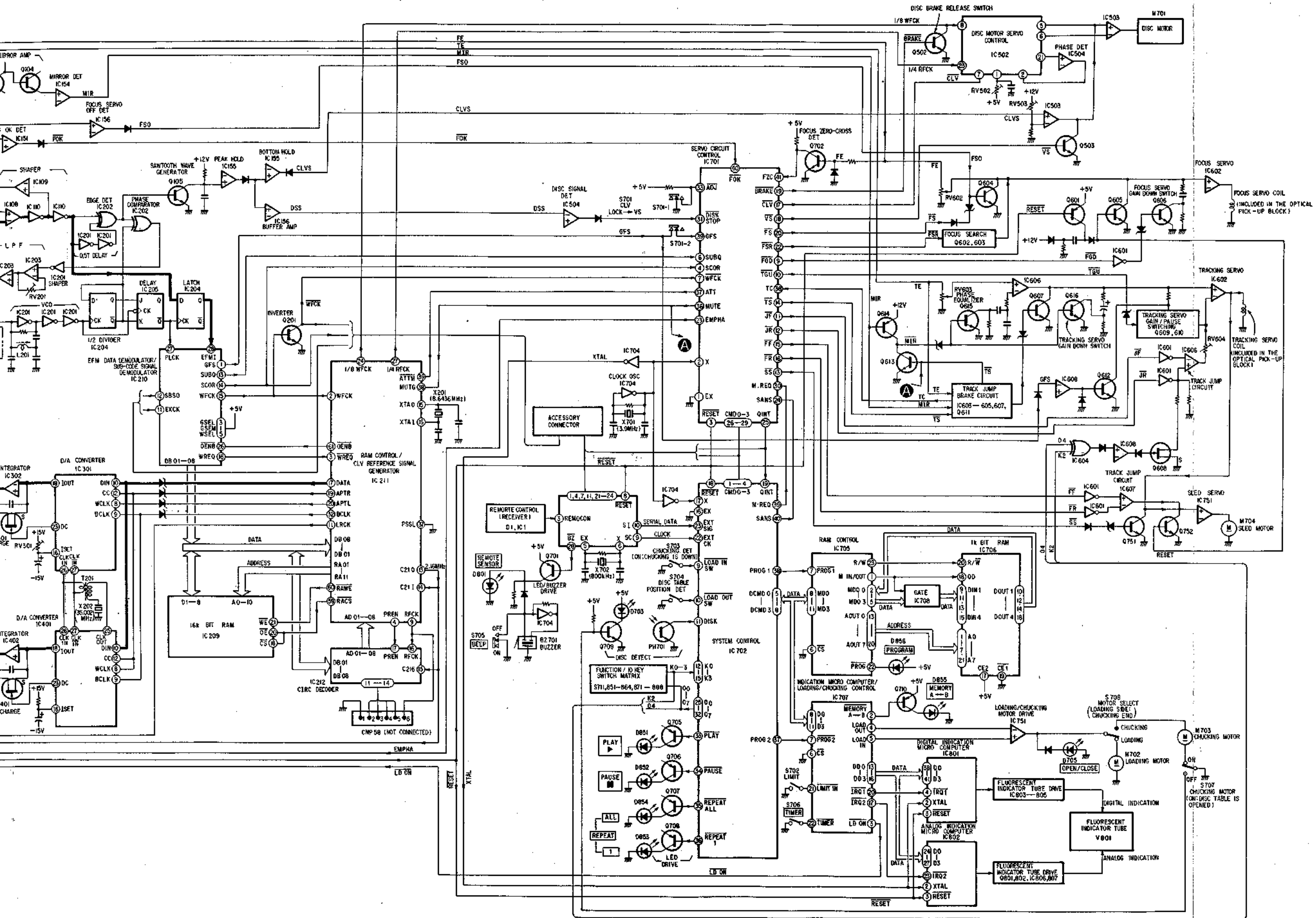

SECTION 2
DISASSEMBLY

Note: Follow the disassembly procedure in the numerical order given.

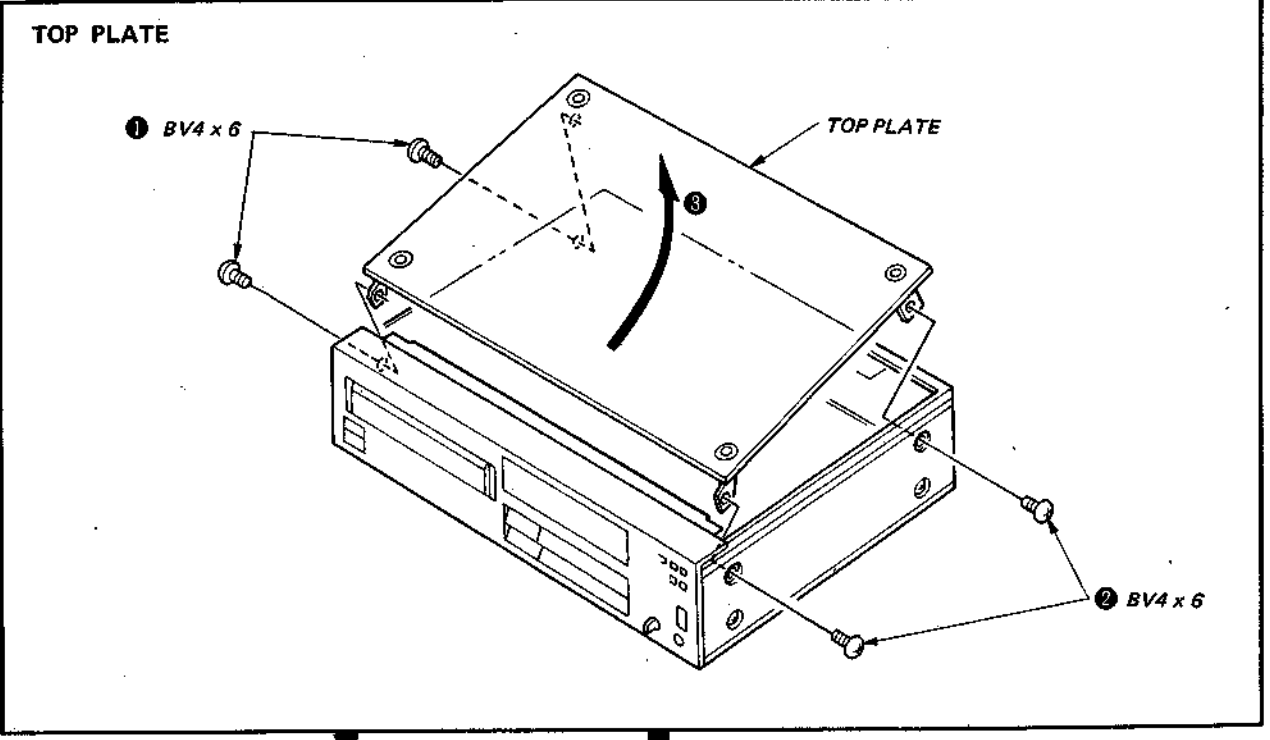

• Component side of servo board can be checked.

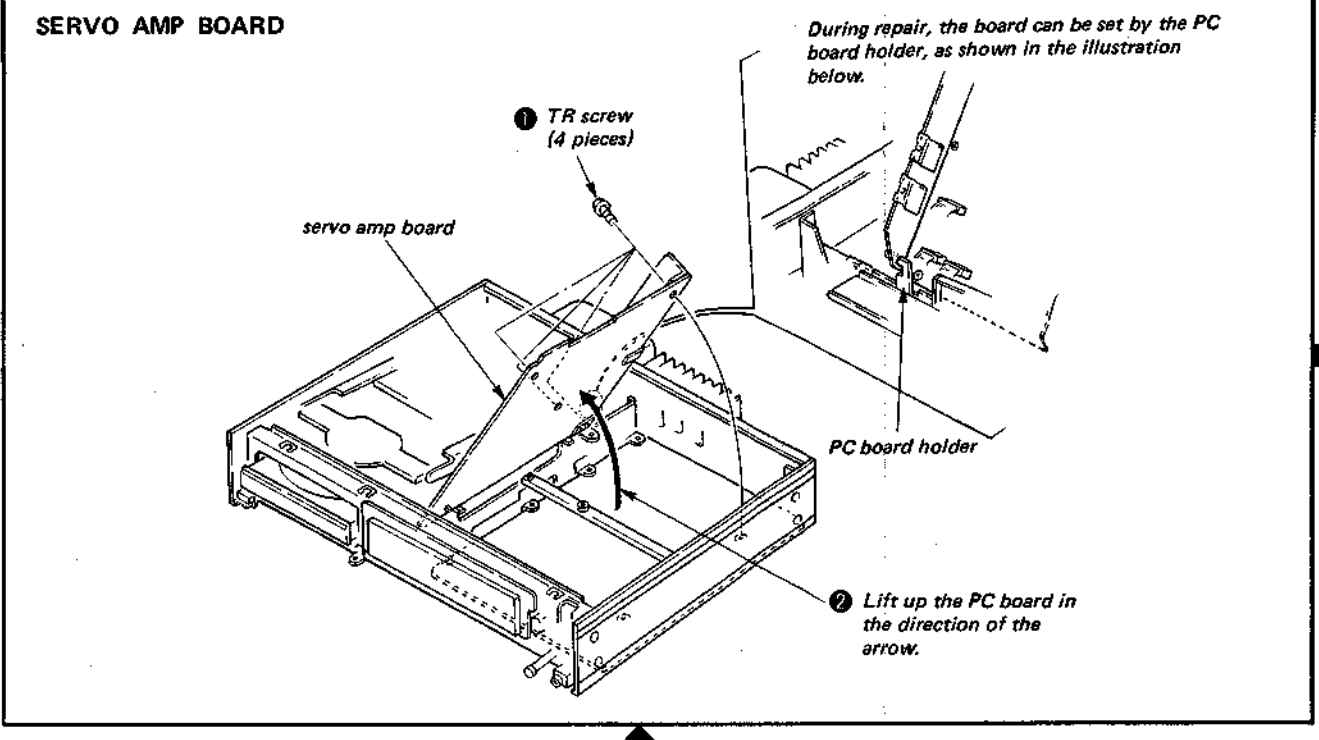

• Conductors and comp board can

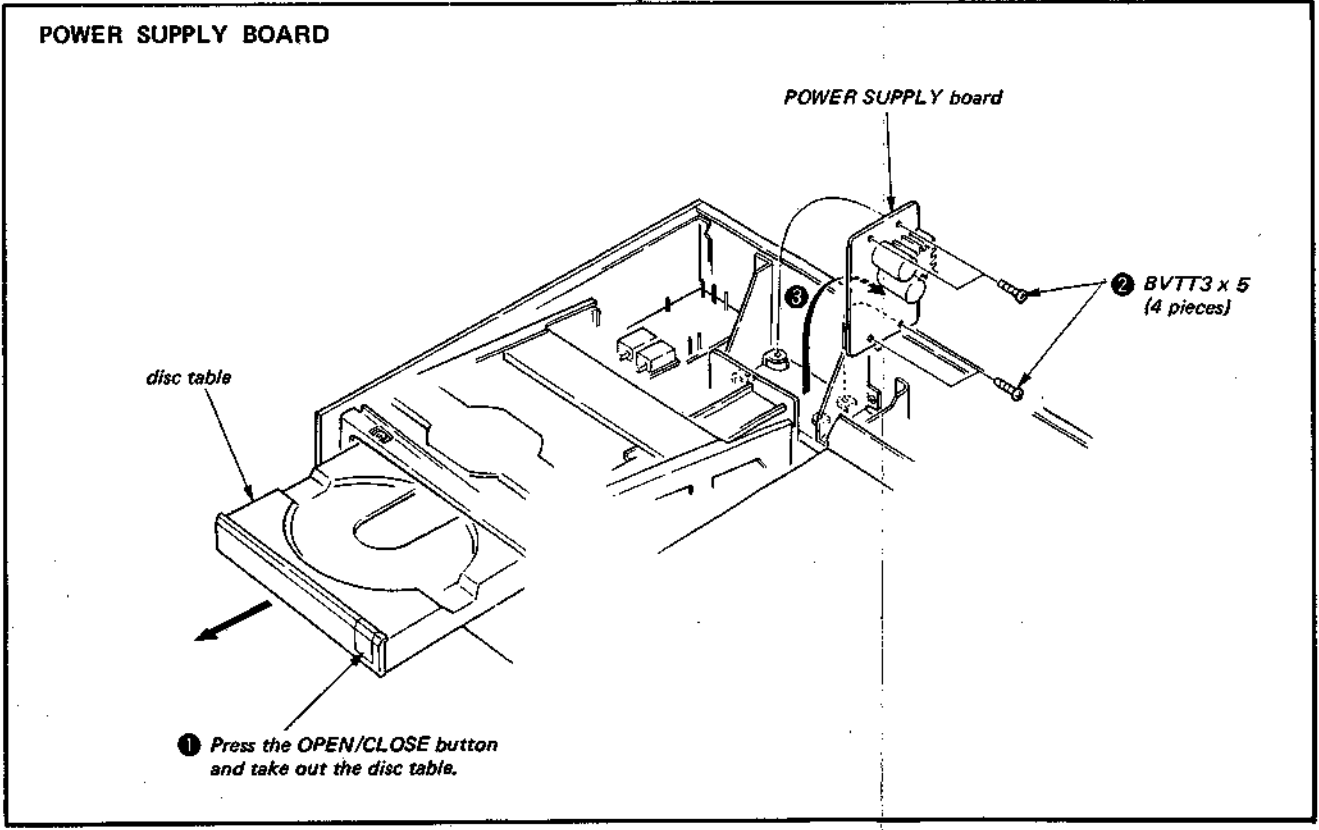
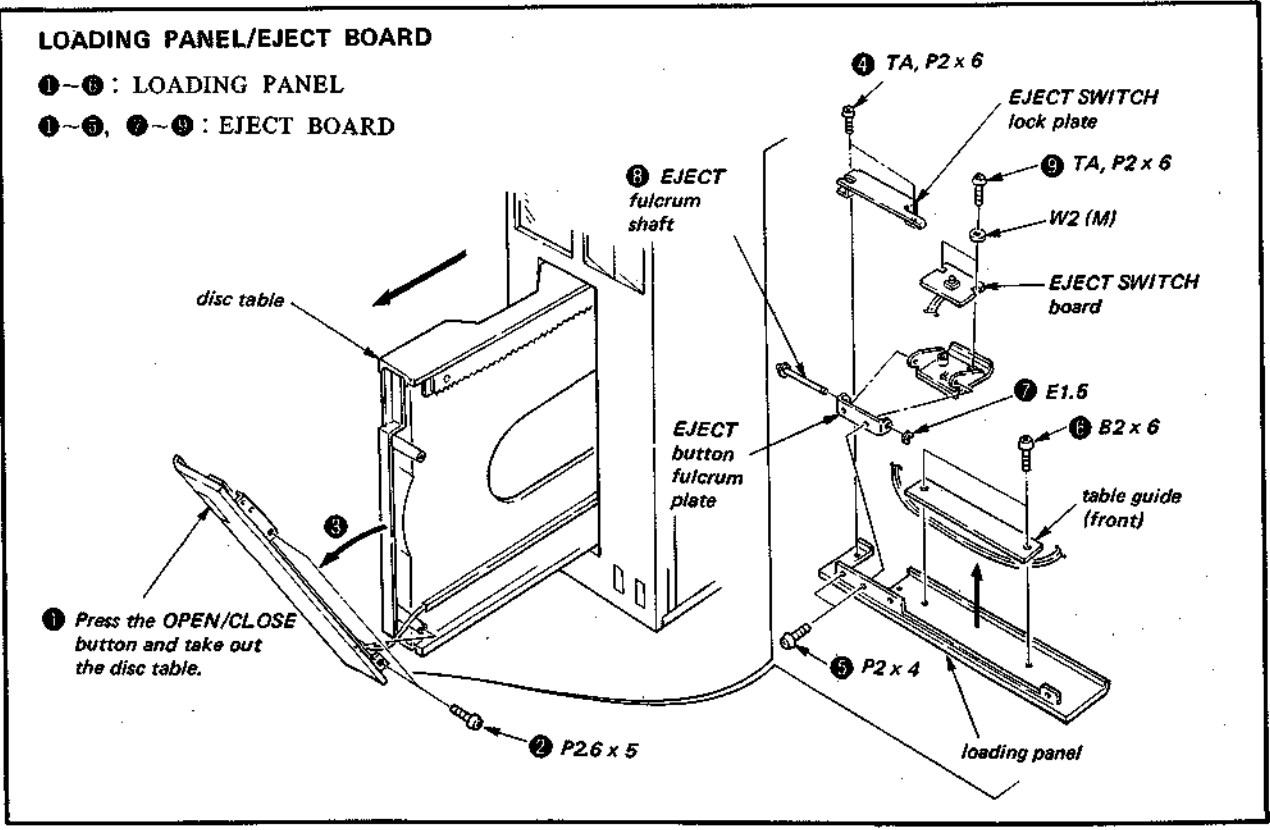

HEAT S

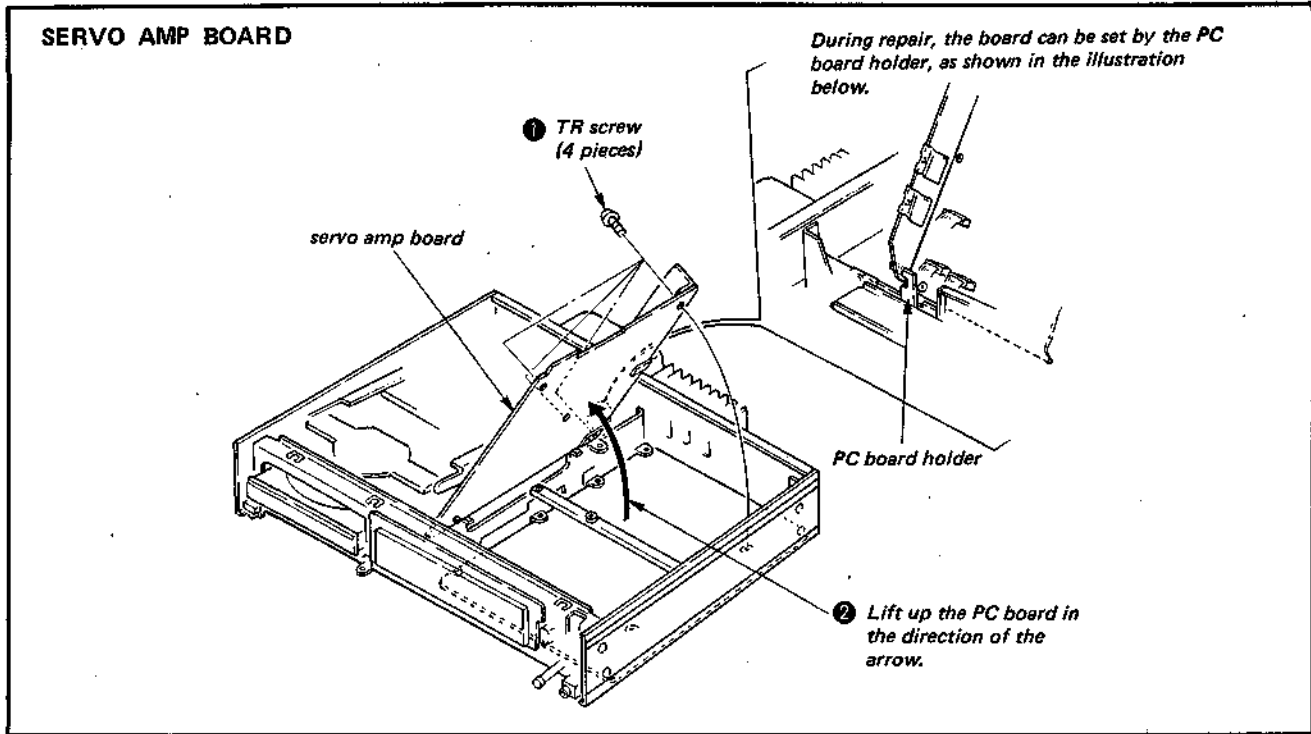

• Conductor side of SERVO board and component side of AUDIO board can be checked.

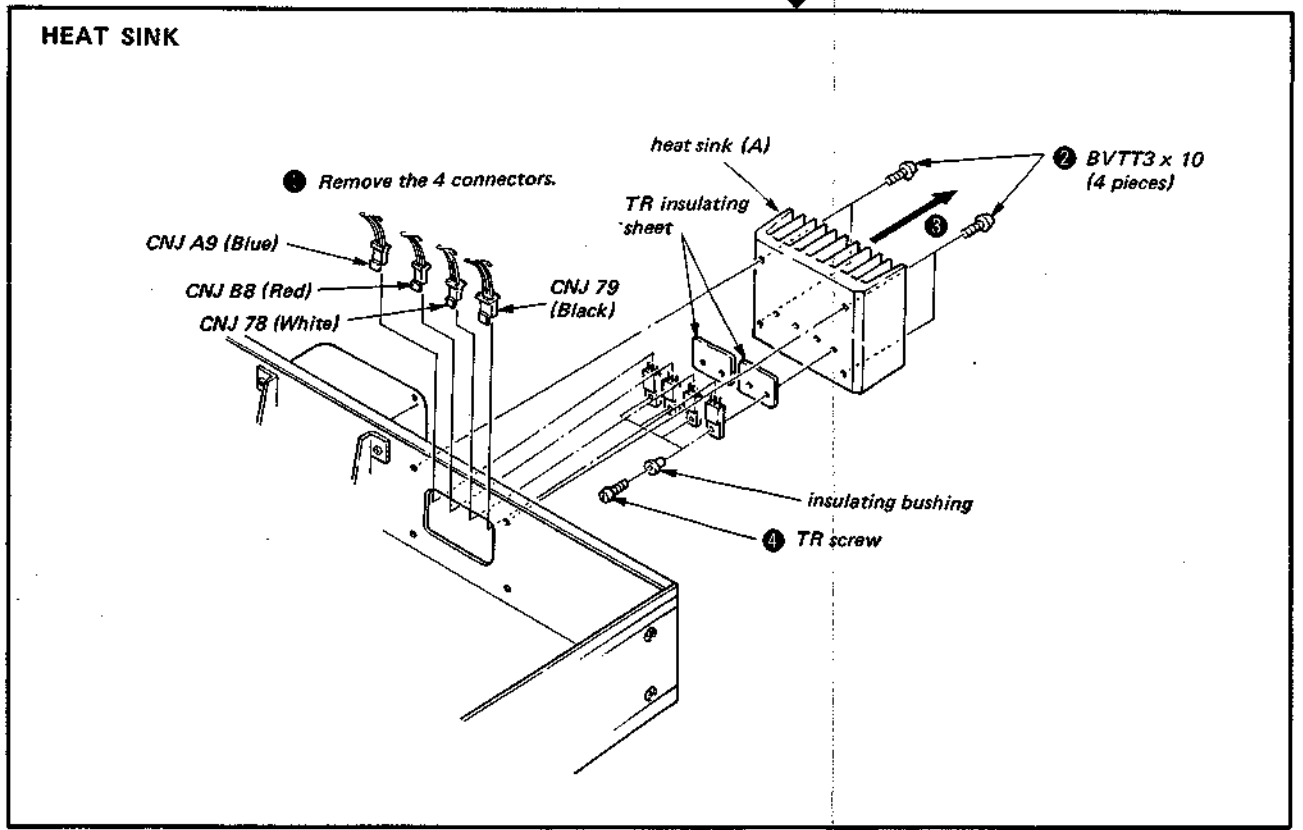
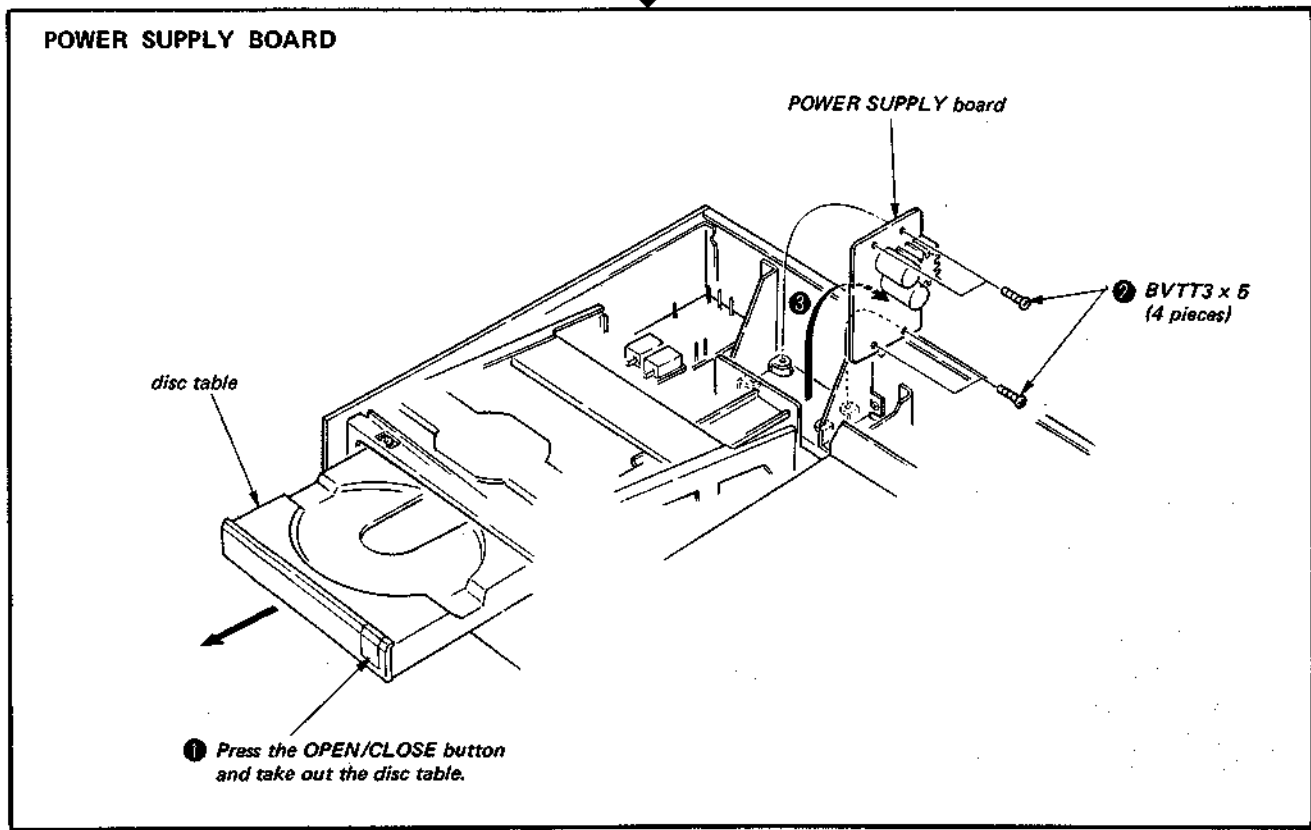
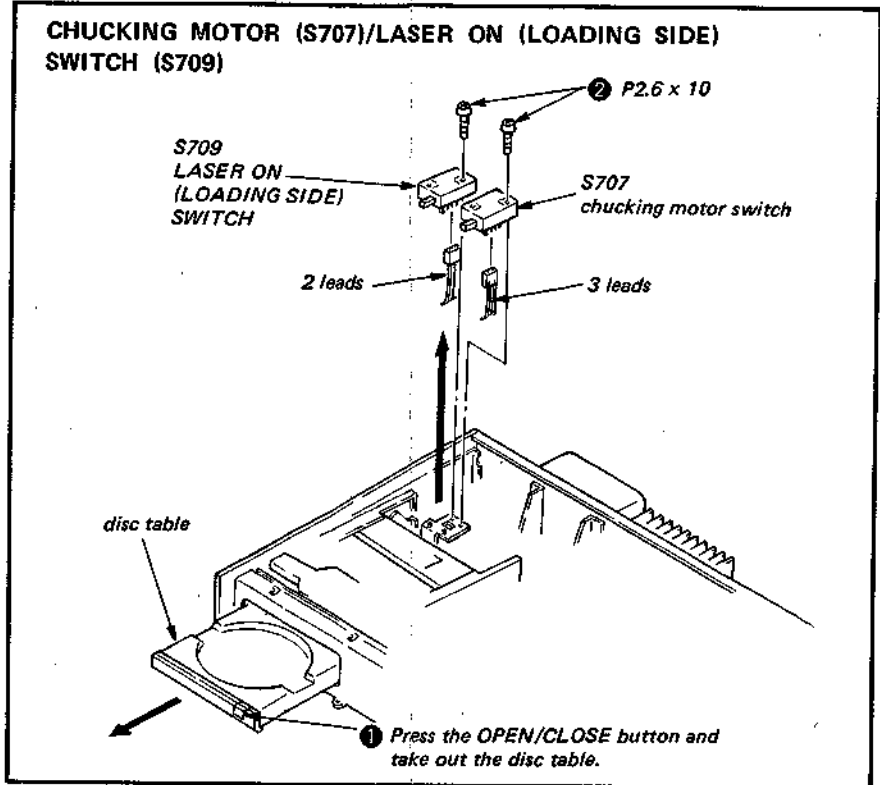

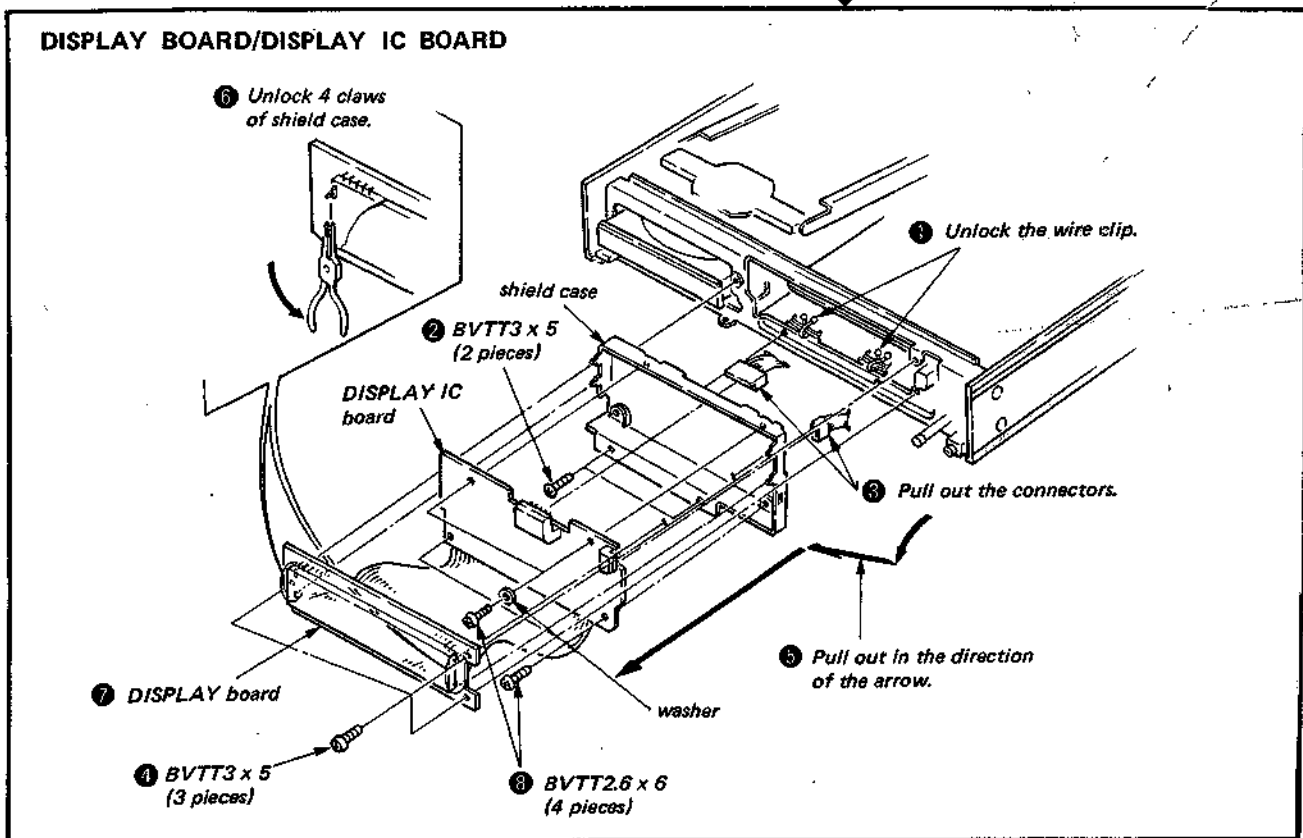
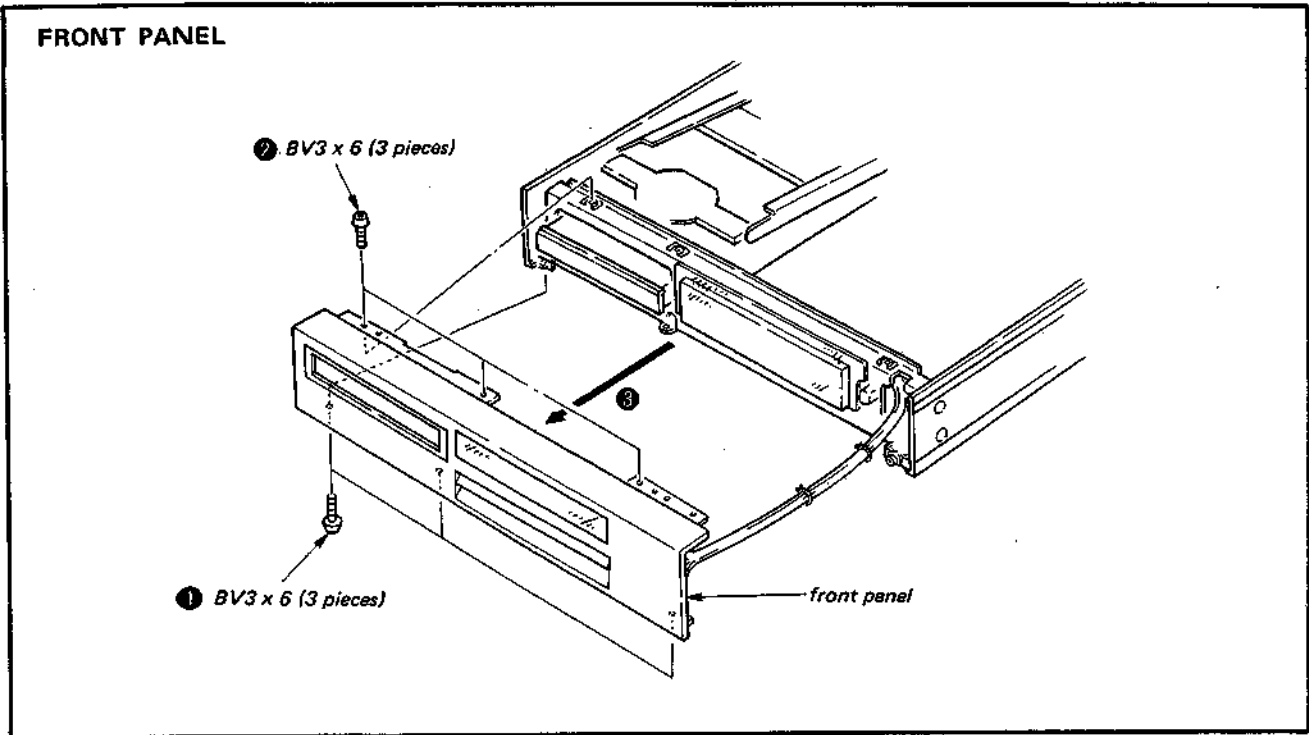

HEADPHONE AMP BOARD/HEADPHONE JACK BOARD

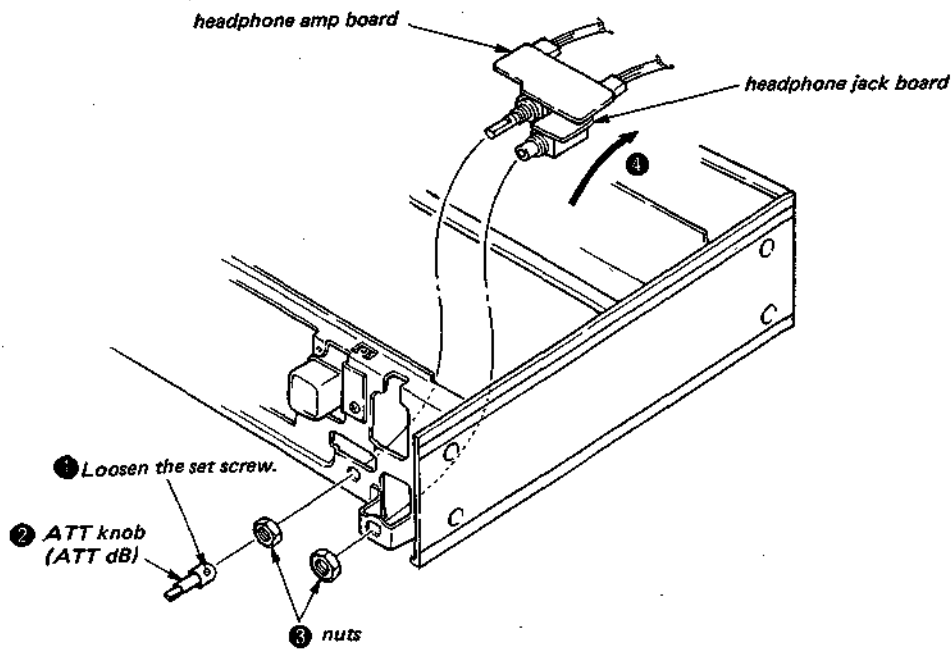

10 KEY BLOCK/CONTROL SWITCH BOARD/CONTROL BLOCK

- ①~⑤ : 10 KEY BLOCK
- ①~⑤ : CONTROL SWITCH BOARD
- ⑥, ⑦~⑩ : CONTROL BUTTON BLOCK

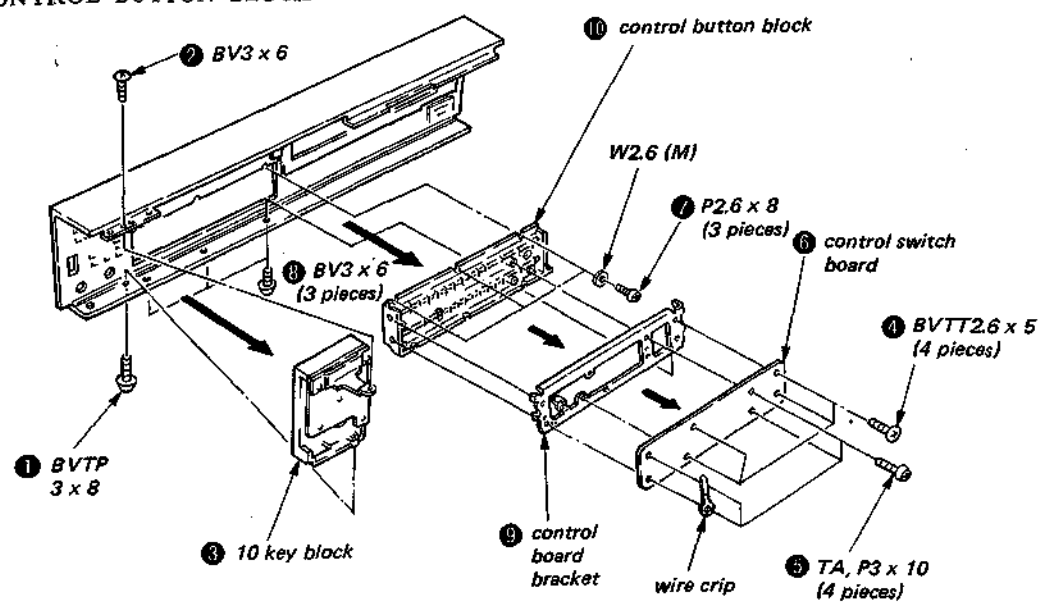

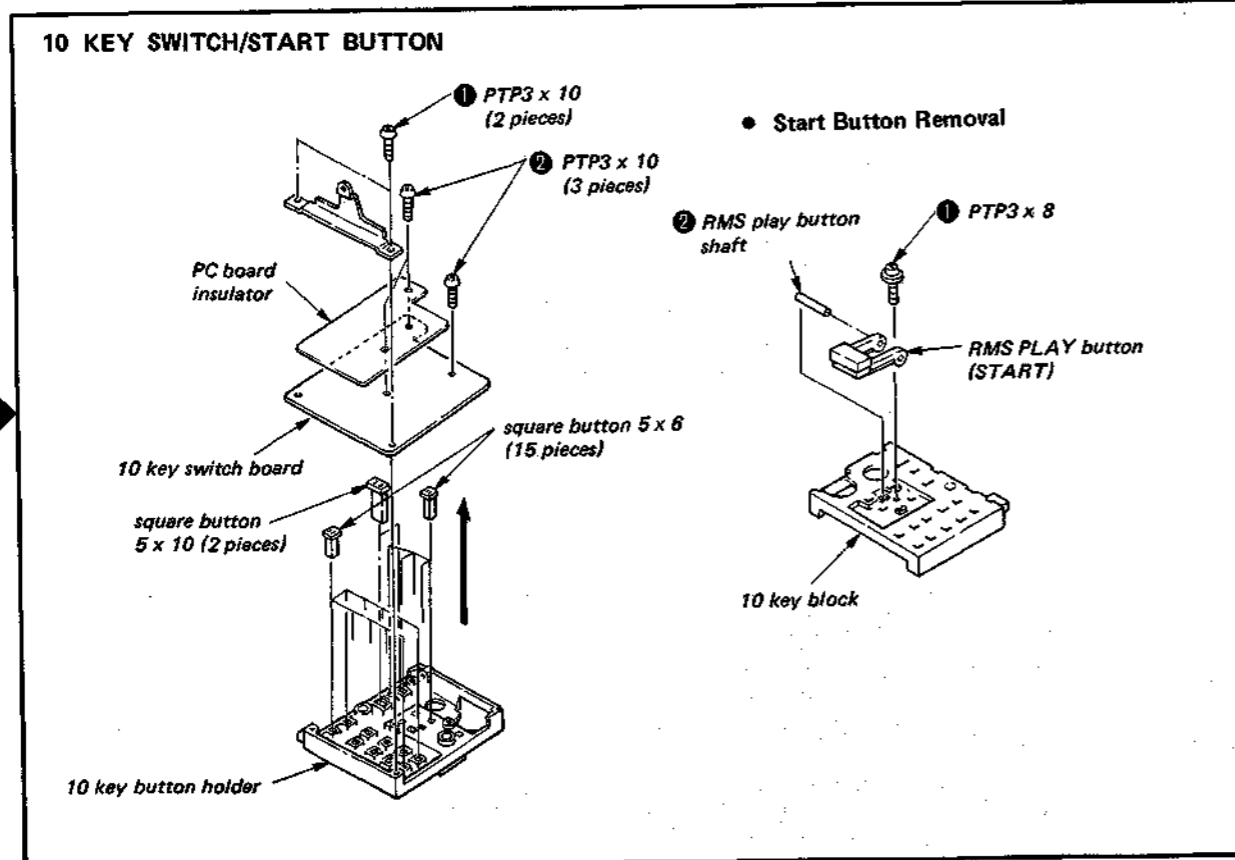
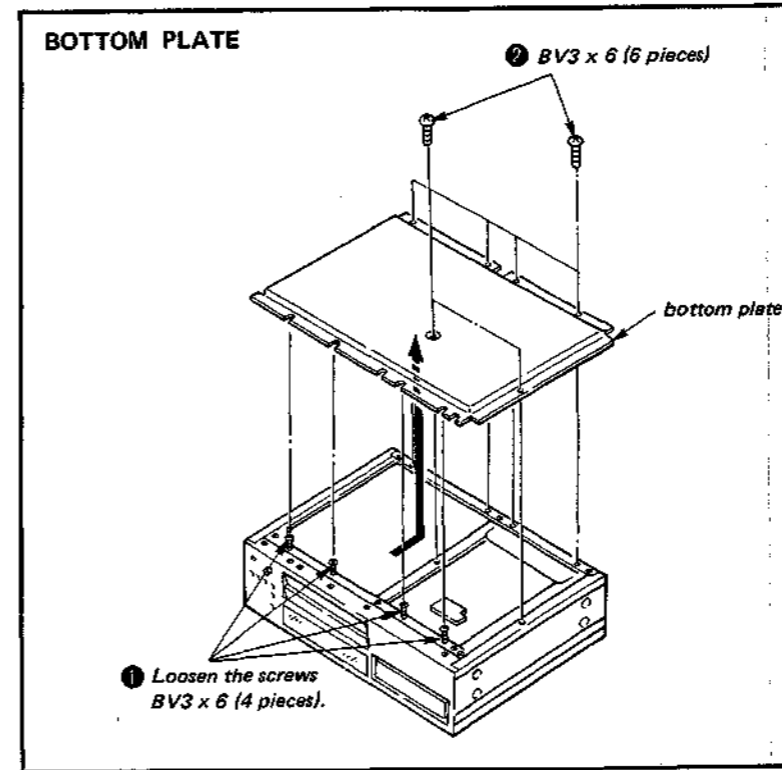
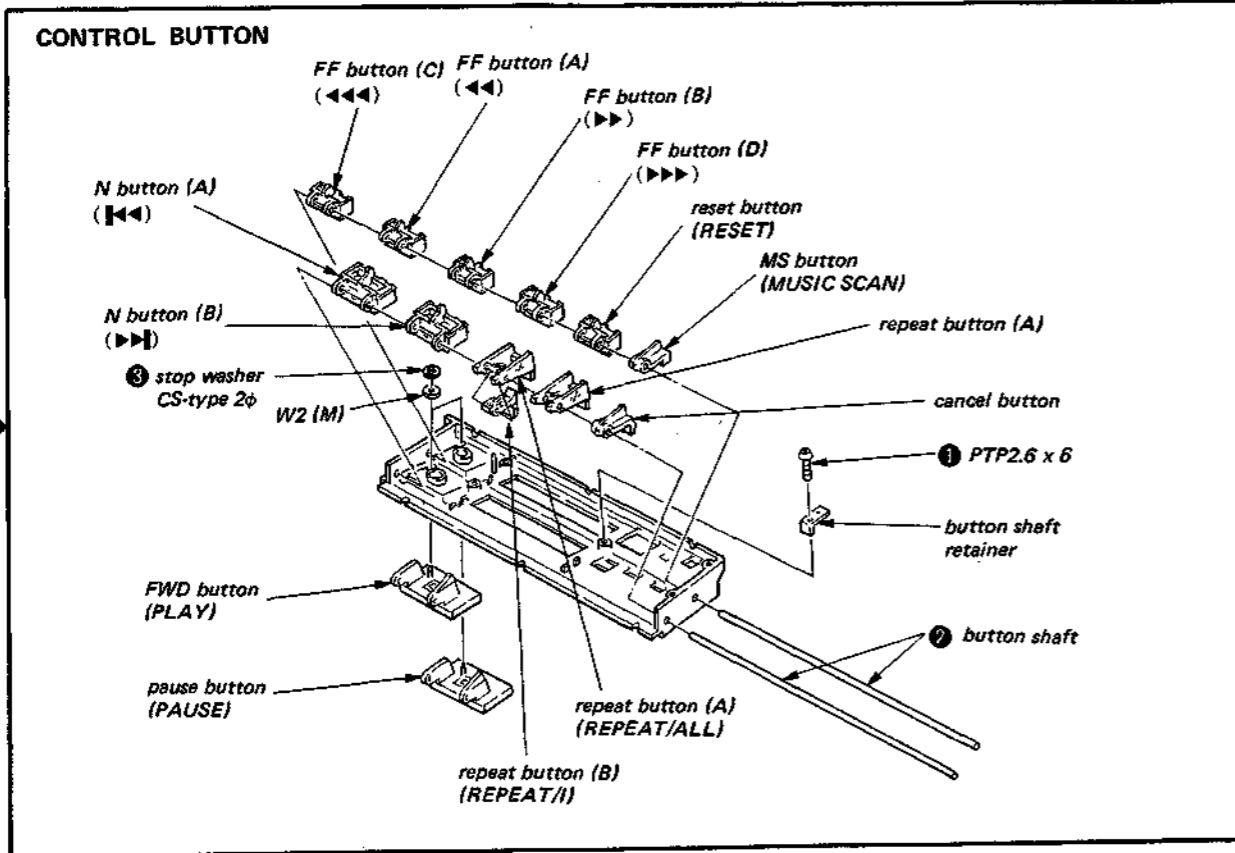

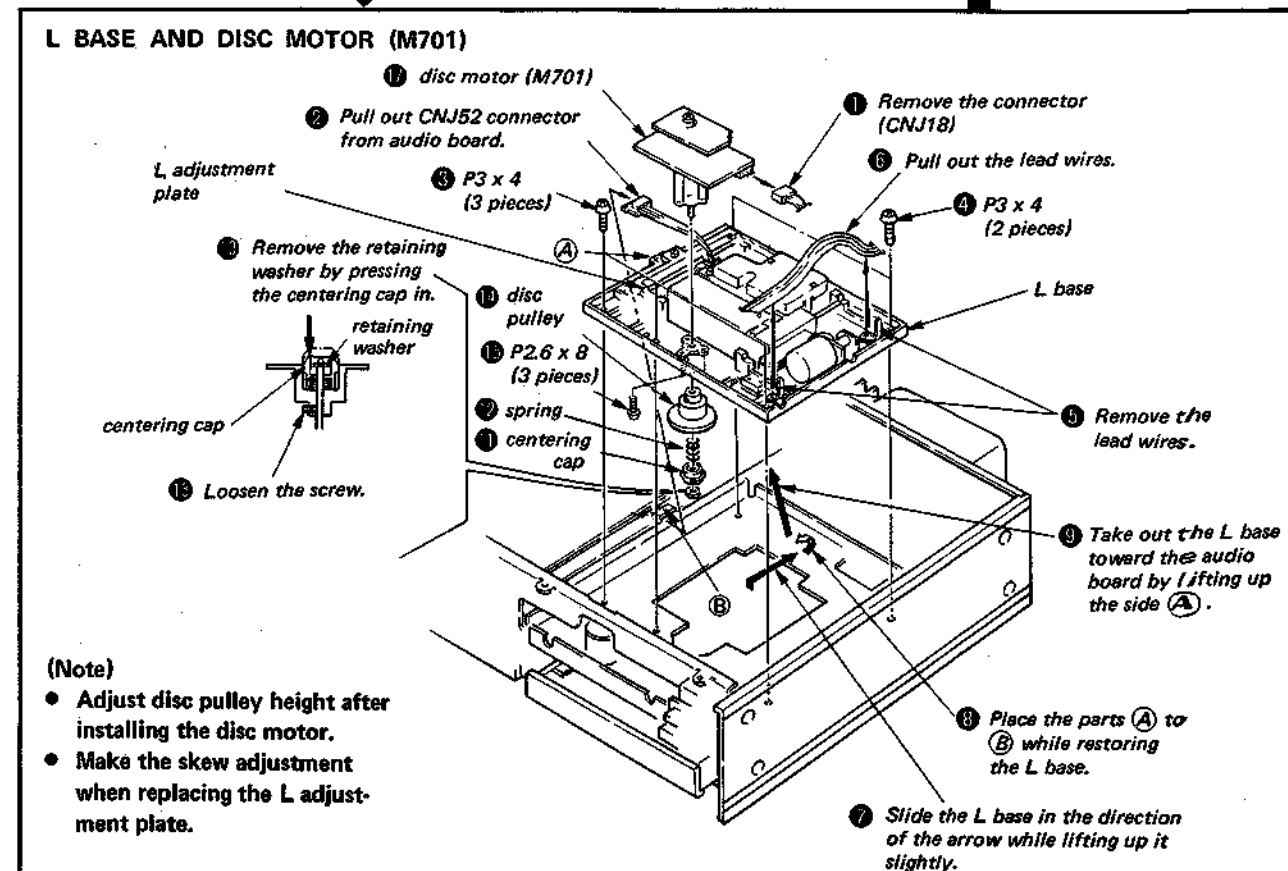
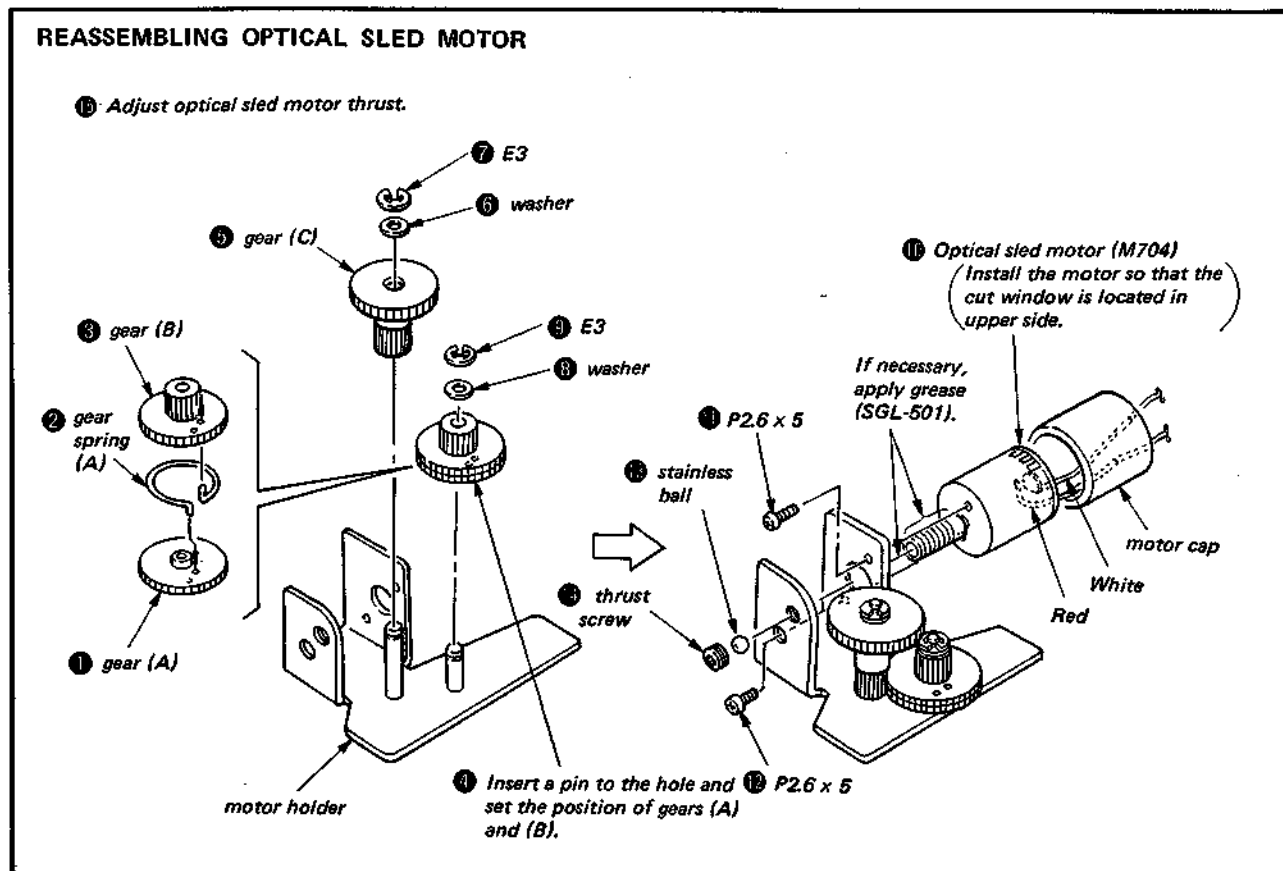
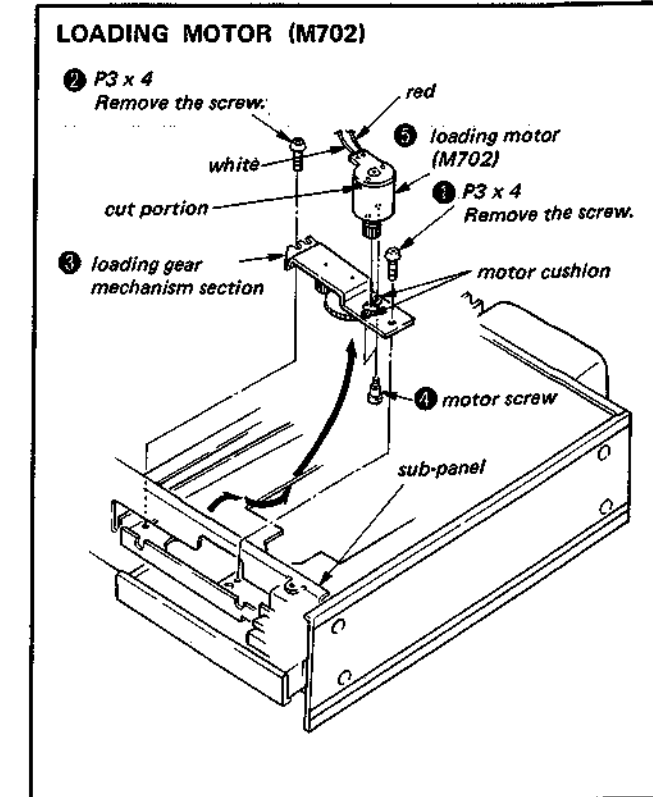
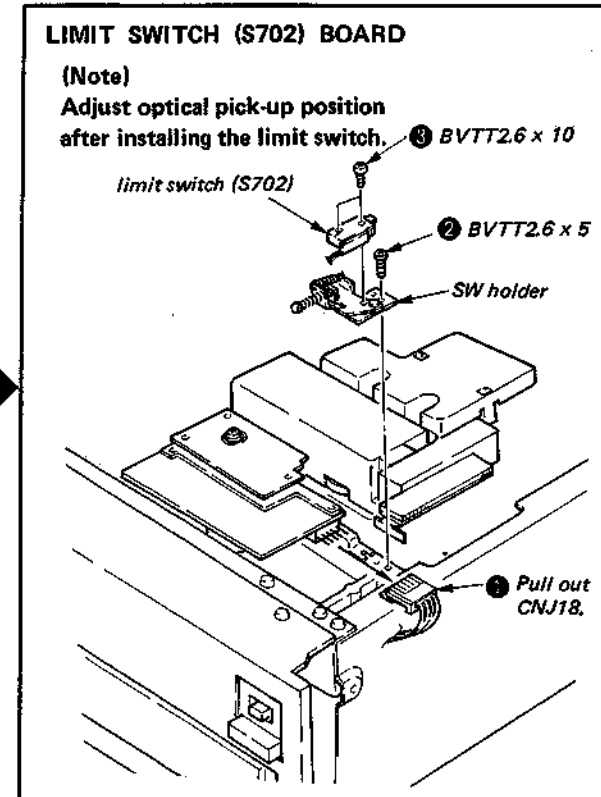
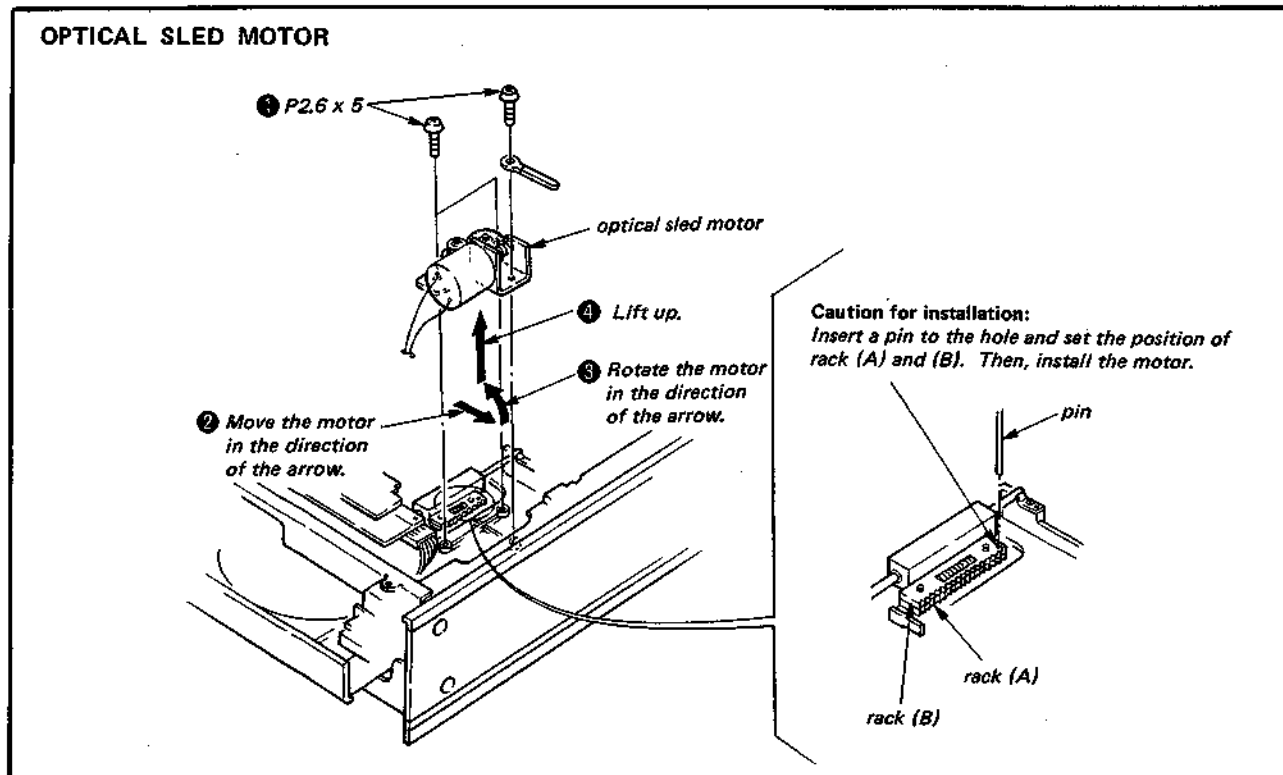

Remove the bottom plate.
(See page 34)

OPTICAL PICK-UP BLOCK

Refer to the Note on Handling the Optical Pick-up Block (KSC-100A). (page 7)

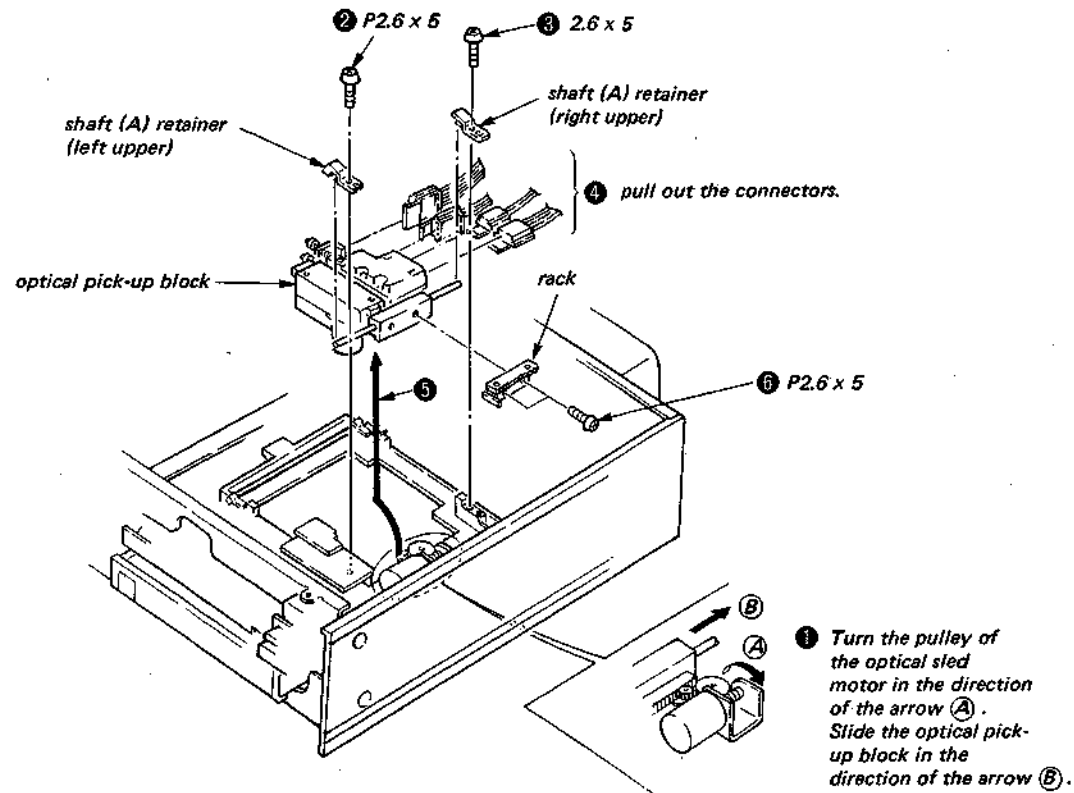

1 Turn the pulley of the optical sled motor in the direction of the arrow (A). Slide the optical pick-up block in the direction of the arrow (B).

When replacing the optical pick-up block, check and adjust the items below in order.

1. RF Balance Adjustment
2. Skew Adjustment
3. Focus Bias Adjustment
(Repeat items 2 and 3 so that eye-pattern clearly appears because skew adjustment and focus bias adjustment are affected each other.)
4. Tracking Level Adjustment
5. Tracking Balance Adjustment
6. Optical Pick-up Block Position Adjustment

After performing the above, confirm focus/tracking gain.

- Checking Focus/Tracking Gain —
Play a disc (YEDS-1) and check the following items.
1. No skipping in the sound.
 2. Mechanical noise when the 2-axis device operates should be minimum.
 3. The beginning of the desired selection is reached when the (<<<, >>>) buttons are pressed. The time for reaching the beginning of a selection should be about 2 seconds.

- Remove the top plate (See page 28)
- Remove the bottom plate (See page 34)

POWER SWITCH BOARD

— bottom view —

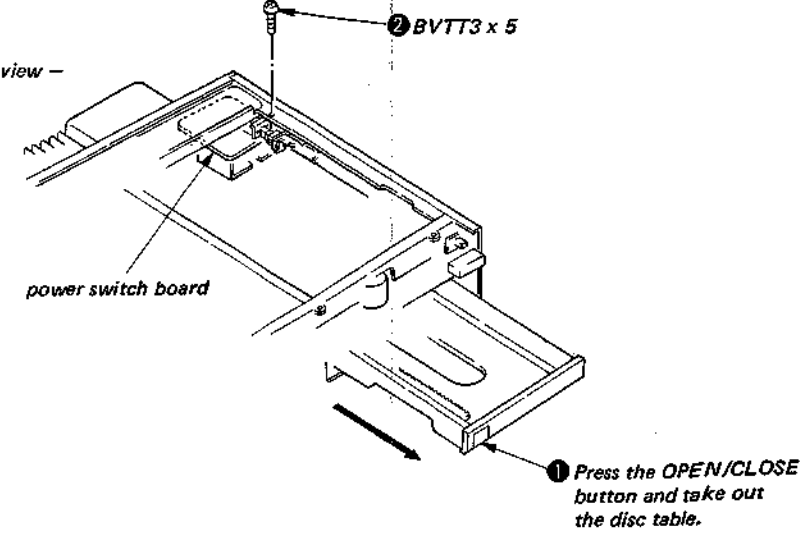

US MODEL

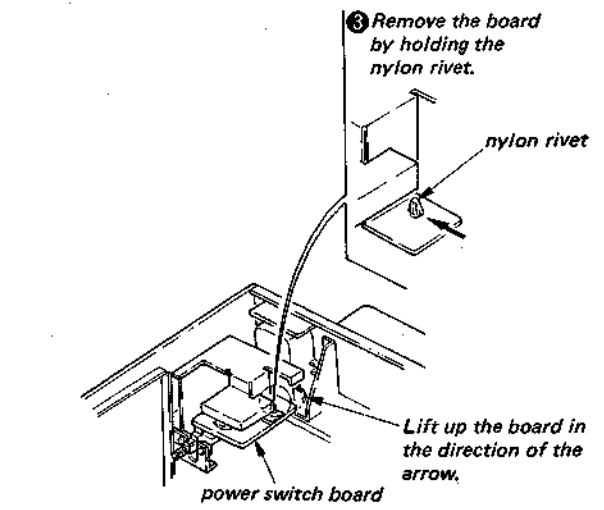

AEP, UK, CANADIAN MODEL

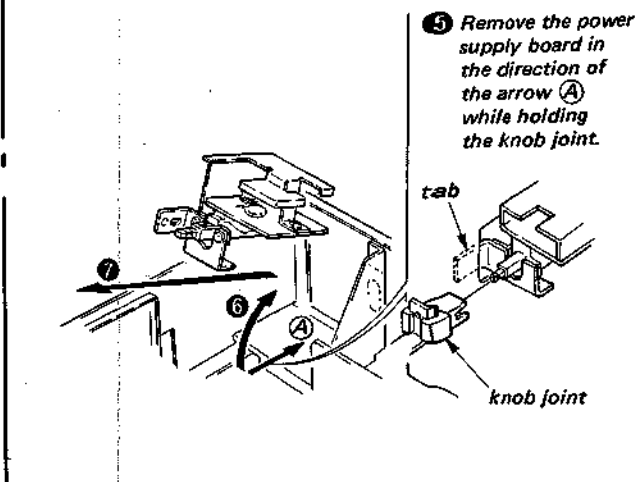
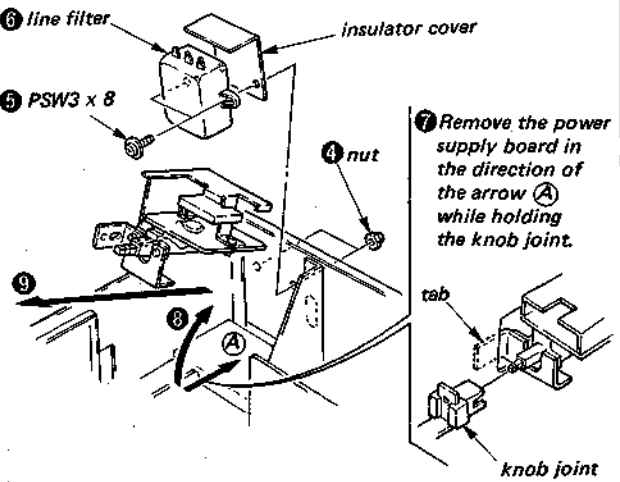
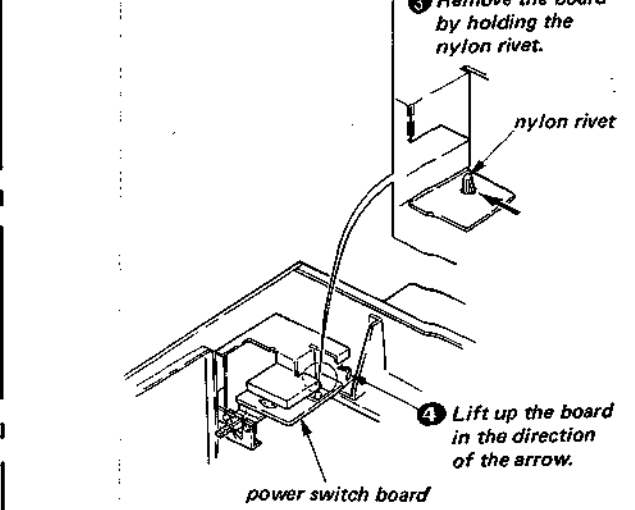

- Remove the top plate (See page 28)
- Remove the bottom plate (See page 34)

LOADING BOARD/CHUCKING MOTOR (M703)

- ①~⑧ : LOADING BOARD
- ①~⑧, ⑩ : M703 (CHUCKING MOTOR)

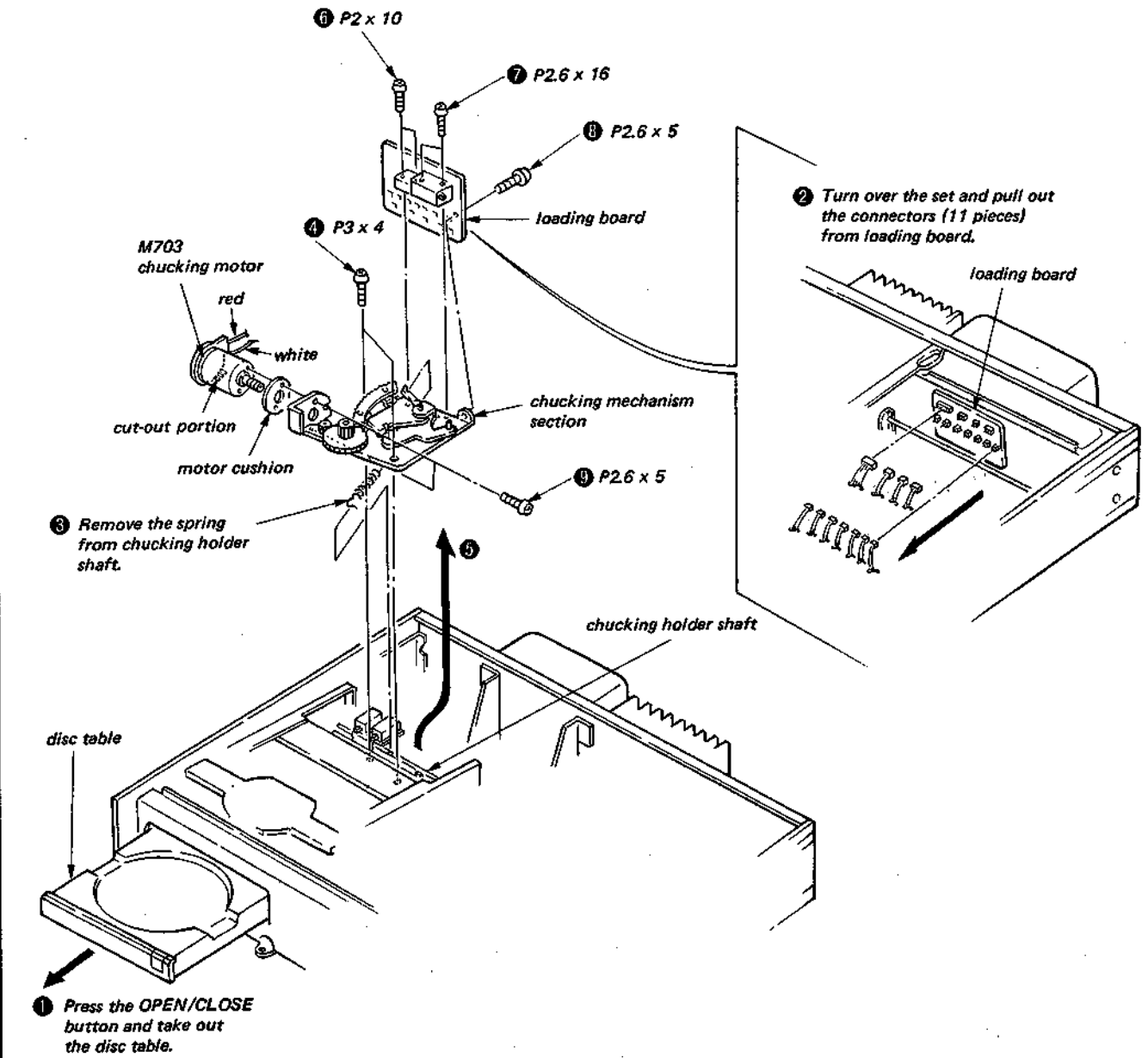

- Remove the top plate (See page 28)
- Remove the bottom plate (See page 34)

MECHANISM SECTION

- ① Turn over the set, pull out the connectors.
- ② Pull out CNJ25 from the servo amp board.

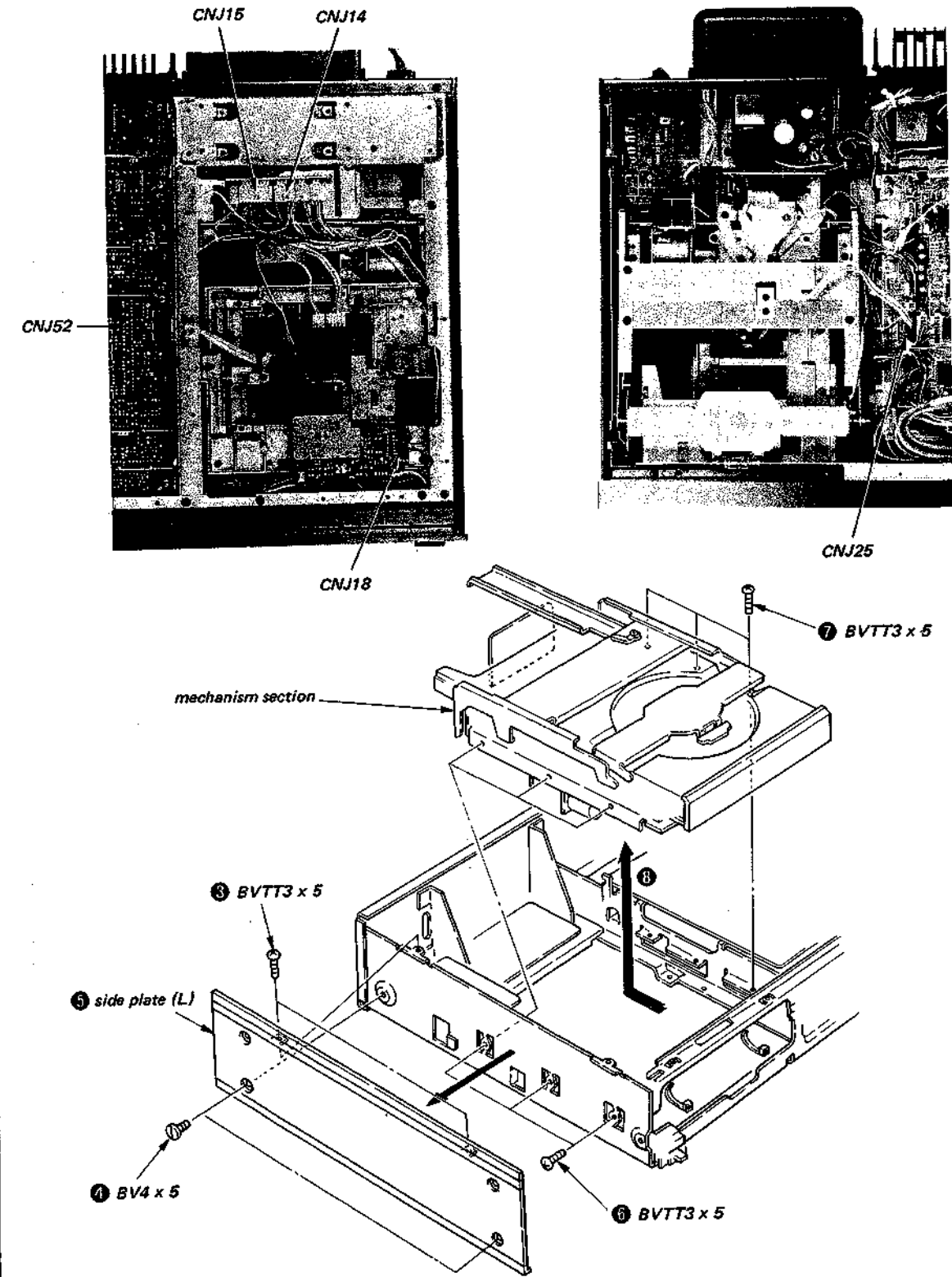

**SECTION 3
ADJUSTMENTS**

3-1. MECHANISM ADJUSTMENTS

Optical Pick-up Position Adjustment

This adjustment determines the position when the optical block is at its innermost position on the disc. It is done so that the optical block can read the information recorded in the TOC (Table of Contents) on the disc lead-in track.

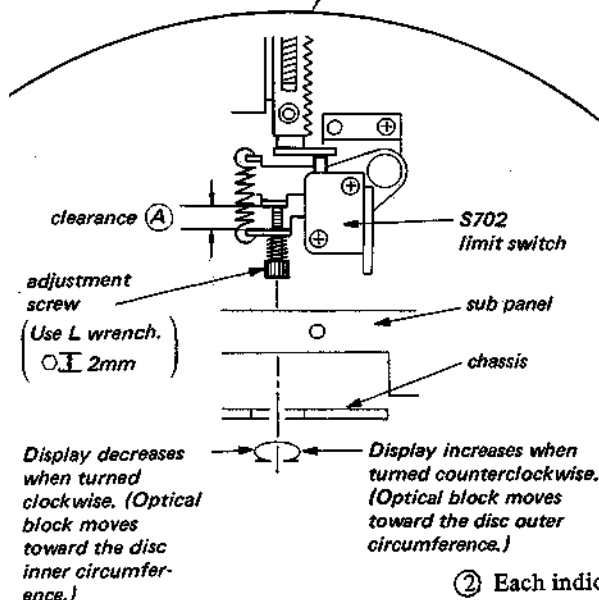
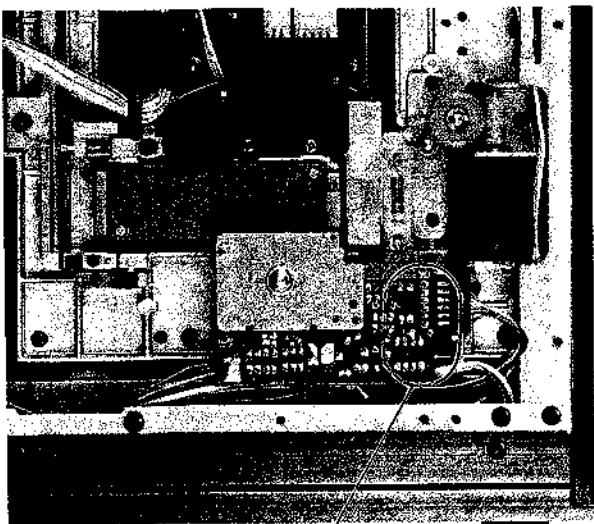

When removing the adjustment screw, first note the clearance (A) of the adjustment screw. After tightening the adjustment screw, perform the following adjustment.

1. Remove the front panel.
2. Turn POWER switch on and insert disc (YEDS-1).
3. Press ▷ PLAY button and adjust the adjustment screw so that the display window reading is as illustrated below.
The adjustment must be completed by turning in the loosening direction.
The timer counter decreases approximately 5-15 seconds with one counterclockwise turn of the adjustment screw.
When turning the adjustment screw, press the OPEN/CLOSE button to reset the microcomputers (IC701, 702, 703). After this, press ▷ PLAY button, read display window and perform adjustment again.
4. Press OPEN/CLOSE button, and after the LED on the OPEN/CLOSE button lights up, press ▷ PLAY button.
Confirm that the display window reading is as illustrated below.
The remaining time will be also checked on the REMAINING TIME indicator.
5. Repeat step 3 about ten times. If there is even one variation from the figure, repeat steps 3 - 4.
6. Press PLAY button to obtain PLAY mode. Press Auto Selection (▶▶▶) button and Manual Search (▶▶▶) button so that the outermost circumference is played. Next press RESET button.
7. Confirm that play begins when ▷ PLAY button is pressed. If it does not, turn the adjustment screw clockwise one time and repeat steps 3 - 7.
8. After the adjustment, apply locking compound.
9. Install the front panel.

- ② Each indicator displayed
- INDEX indicator : ;
- Time counter : 0M 00S
- Remaining time indicator : 52M 53S

- Display window -

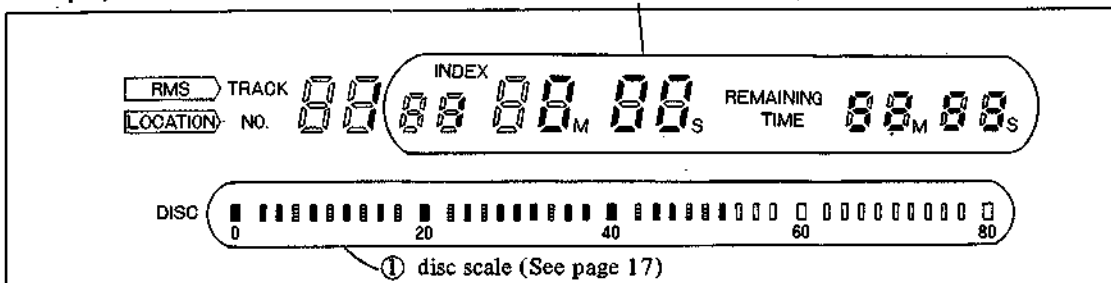

Optical Sled Motor Thrust Adjustment

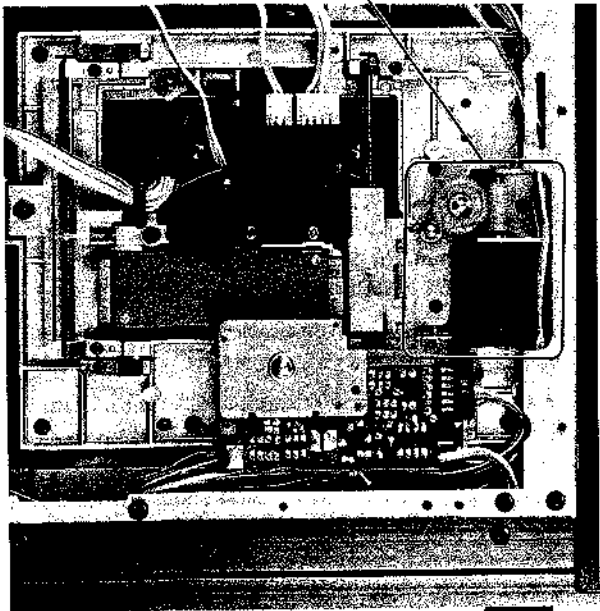
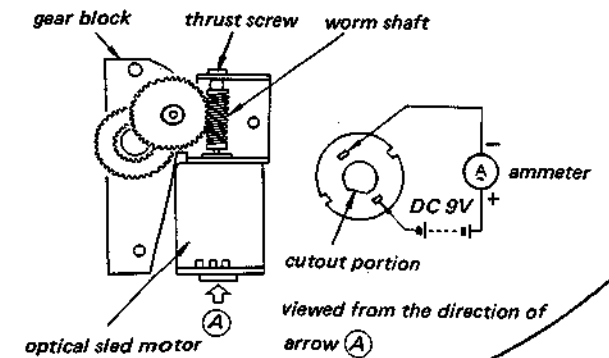

1. Remove gear block.
2. Turn thrust screw counterclockwise to loosen.
3. Connect as shown above and remember the ammeter reading.
4. Next, turn the thrust screw clockwise slowly and adjust so that the ammeter reading is +1mA from the reading in step 2.
Motor drive current must be less than 25mA.
Reference value: 17 – 20mA.
5. Confirm that there is no worm shaft thrust play.
6. After adjustment, lock the screw.
7. Install the gear block.

Disc Pulley Height Adjustment

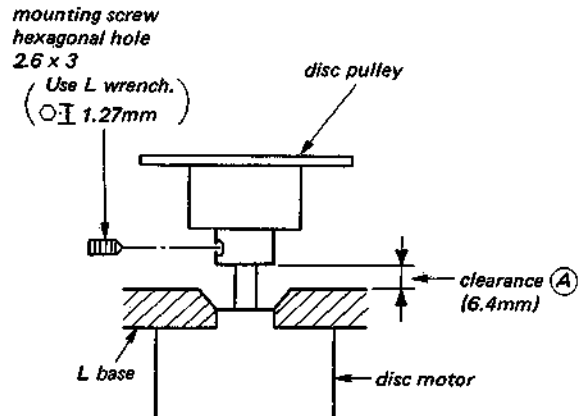

1. Turn the motor height adjustment screw fully counterclockwise.
2. Install the disc pulley so that clearance (A) is 6.4mm.
3. Make the skew adjustment.
(See page 43)

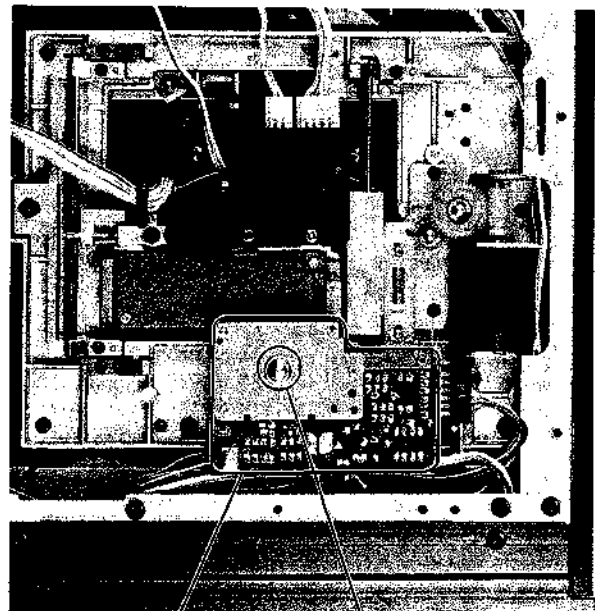

M701 disc motor motor height adjustment screw

Skew Adjustment

This adjustment is to align the optical block objective lens and the disc surface parallel. Perform when replacing the disc motor (M701), optical block and L adjustment plate.

Procedure:

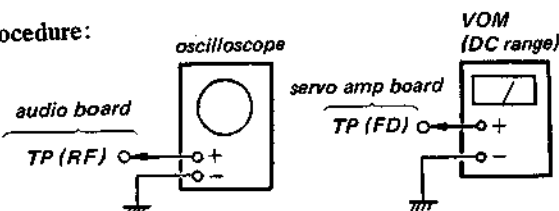

1. Turn the POWER switch on, insert the disc (YEDS -1) and press the PLAY ▷ button.
 2. Connect the oscilloscope to the audio board test point (RF).
 3. Adjust the skew adjustment screw so that the oscilloscope waveform eye pattern is good or so that the waveform is maximum.
A good eye pattern is one where the ◊ shape in the center of the waveform is clear.
When observing the eye pattern, it is easier if the oscilloscope is set for AC range and oscilloscope vertical sensitivity is raised.
 4. Connect the volt-ohm meter to the servo amp board test point (FD).
 5. Adjust the motor height adjustment screw so that the meter reads 0V DC.
 6. The skew screw adjustment and motor height screw adjustment affect each other, so repeat steps 2 - 5 two or three times in order to get the best possible eye pattern.
- Note:** The skew screw adjustment must be completed by turning in the tightening direction.
7. After adjustment, apply screw lock.
 8. Make the focus bias adjustment (See page 48).

Adjustment Location:

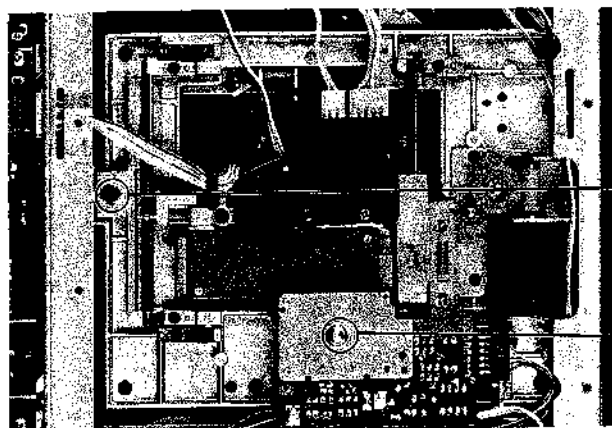

— Audio board —

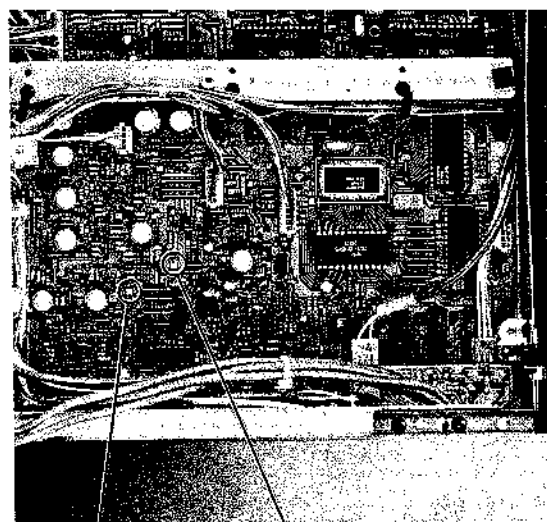

TP (RF) TP (GND)

— Servo amp board —

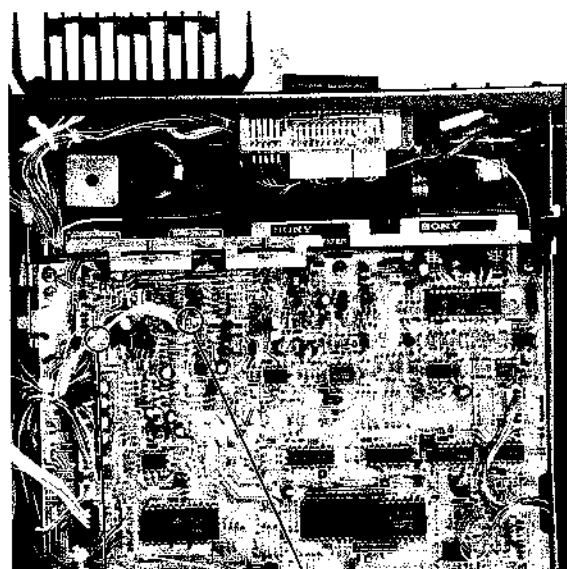

TP (GND) TP (FD)

Skew adjustment screw

Motor height adjustment screw

Loading Stopper Adjustment

This adjustment is to prevent the disc table from coming forward due to loading gear backrush when the disc table is closed and chucking completed.

1. Close the disc table.
2. Loosen the adjustment screw.
3. Push the loading stopper in the direction of the arrow, so that it touches the loading stopper holder lightly.
(See figure below.)
4. Tighten the adjustment screw.
5. After adjustment, apply screw lock.
6. Perform chucking operation twice and confirm that the set correctly operates.

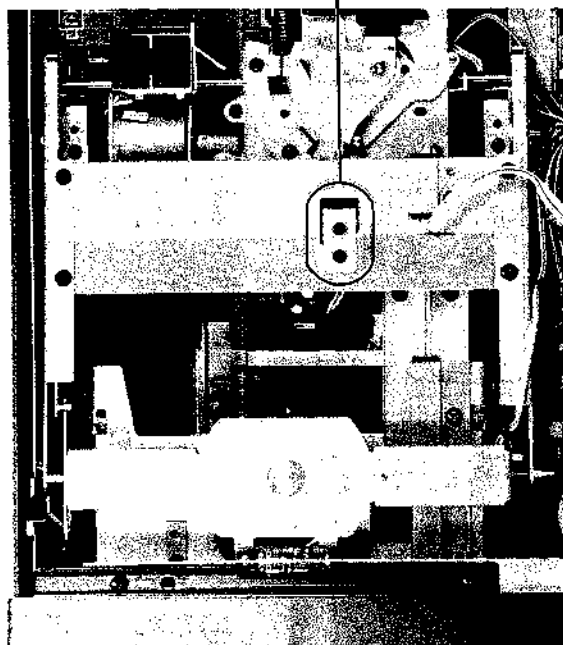
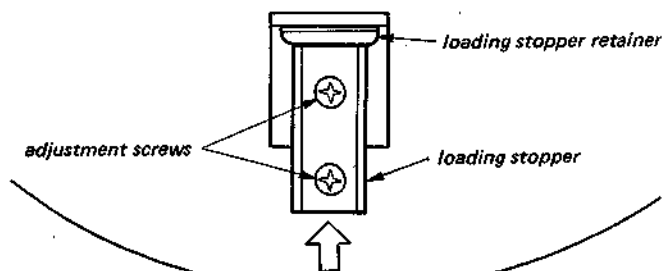

2. ELECTRICAL ADJUSTMENTS

1. Perform adjustments in the order given.
2. Use YEDS-1 disc unless otherwise indicated.
3. Set the unit horizontal.

Adjustment Mode

1. Set CLV switch (S701) to VS side of servo amp board.

This is in order to fix the servo circuit in disc retraction state.

(When CLV switch goes to VS side)

- Microcomputer IC701 pin 39 (GFS) goes low data cannot be read properly.
- Microcomputer IC701 pin 33 (ADJ) goes low . . disc is not ejected even when pits cannot be read.

2. Turn POWER switch on.
(To reset microcomputer.)
After the adjustment, reset CLV switch (S701) to LOCK side.

— Servo amp board —
(Component side)

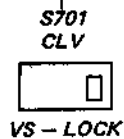
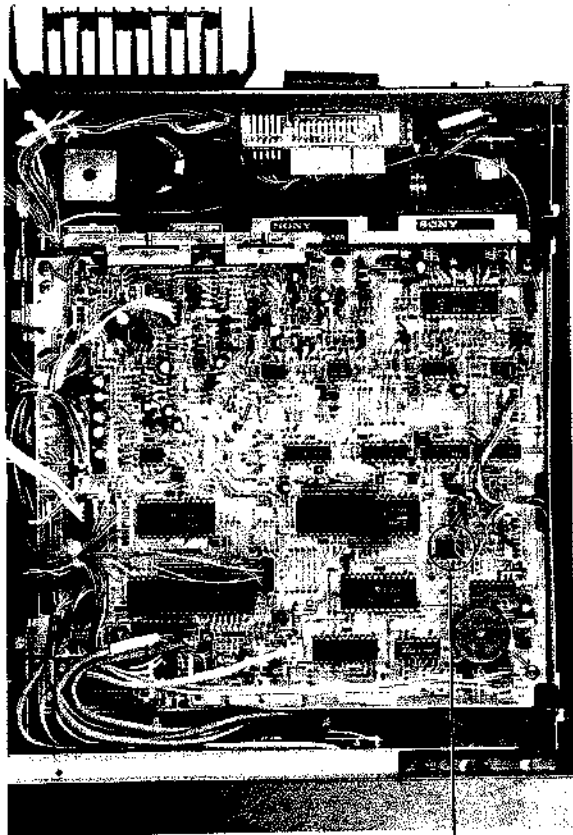

RF Balance Adjustment

Procedure:

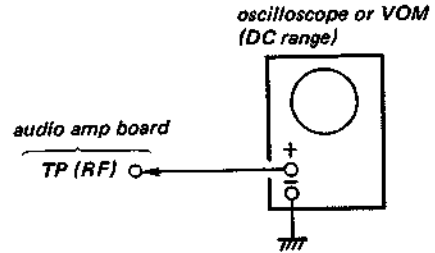

1. Turn POWER switch on. (STOP mode)
2. Connect oscilloscope or VOM to audio amp board test point (RF).
3. Adjust RV101 so that oscilloscope or VOM reading is DC -1.6V.

Adjustment Location: Audio amp board

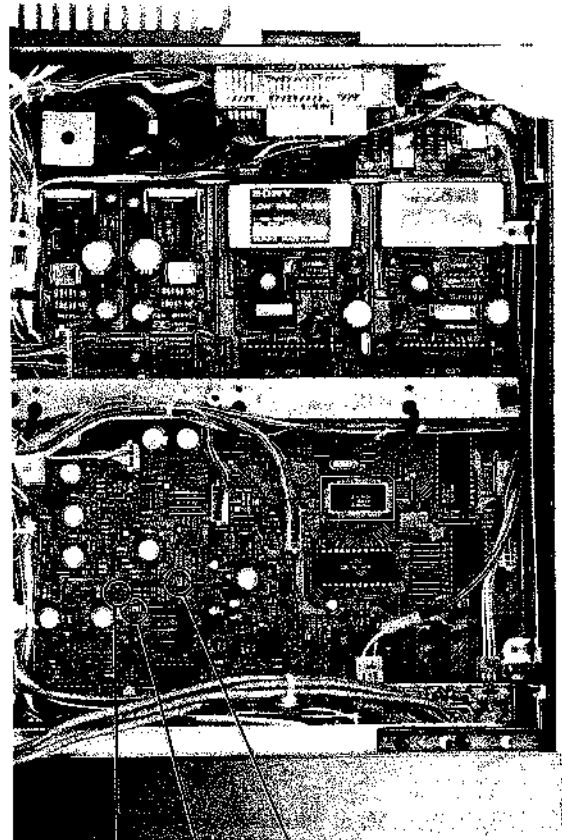

RV101 TP (RF) TP (GND)

RF PLL Adjustment

Procedure:

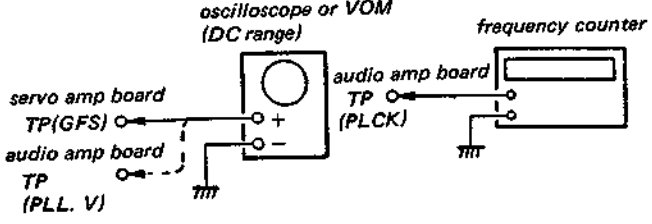

1. Turn Power switch on.
Insert the disc and press the play button (▷).
2. Set the CDP-701ES to the adjustment mode (refer to the page 45), after starting the play.
3. Connect oscilloscope to servo amp board test point (GFS).
4. Confirm that the oscilloscope waveform is "H" as shown in the figure below.

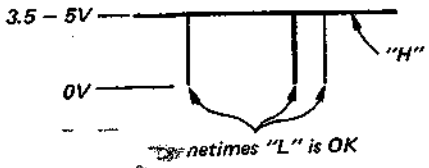

Confirm the following items when the waveform is as shown above. If it is not, perform the adjustments in steps 5-16.

- A. Connect oscilloscope or VOM to audio amp board test point (PLL. V) and read the voltage value.
Reading: DC $0 \pm 1V$
 - B. Connect frequency counter to audio amp board test point (PLCK) and read frequency.
Reading: $4.3218MHz \pm 20kHz$
- When waveform is not as shown above, perform the adjustments in steps 5-16.
5. Turn RV503 fully counterclockwise.
(To unlock the disc servo.)
 6. Connect oscilloscope or VOM to audio amp board test point (PLL. V).
 7. Adjust RV201 so that the reading is DC $0 \pm 5V$.
 8. Connect frequency counter to audio amp board test point (PLCK).

9. Adjust L201 so that frequency counter reading is $4.3218MHz \pm 20kHz$.
10. The adjustment of RV201 and L201 affect each other, so repeat steps 7 - 9 two or three times, finishing with step 9.
11. Adjust RV503 so that the intermittent sound reduces.
12. Connect oscilloscope to servo amp board test point (GFS).
13. Confirm that the waveform is like the one shown in step 4.
If it is not, repeat steps 5 - 13.
14. After the adjustment, reset CLV switch (S701) to LOCK side.

Adjustment Locations:

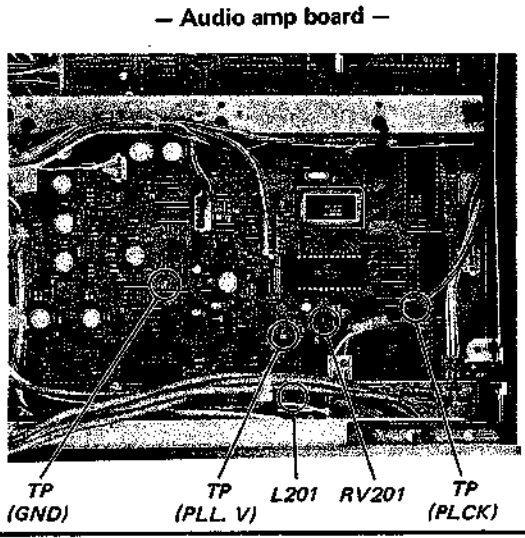
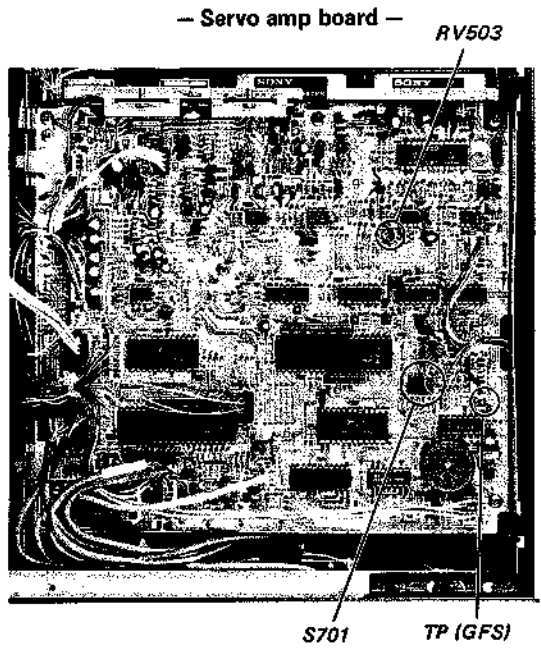

TP (PLL. V) oscilloscope waveform

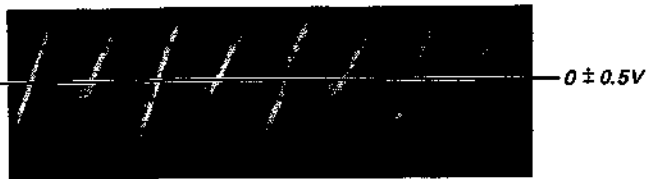

CDP-701ES

Focus Bias Adjustment

Procedure:

Adjustment Location: Audio amp board

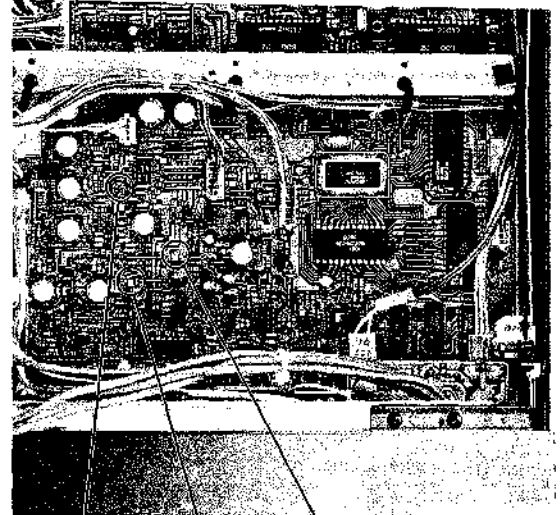
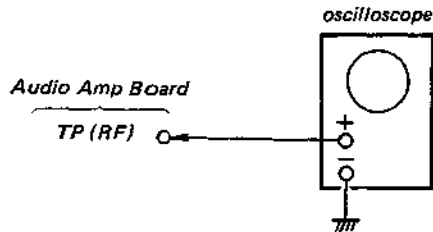

1. Turn Power switch on and insert disc (YEDS-1) and press the PLAY (▷) button.
2. Connect oscilloscope to audio amp board test point (RF).
3. Adjust RV151 by turning it clockwise so that the clear eye pattern appears or the highest waveform is obtained.
(Be sure to complete the adjustment while turning RV151 clockwise).

Note: The clear eye pattern means that a shape distinctly appears at the center of the waveform.

RV151 TP (RF) TP (GND)

RF signal waveform

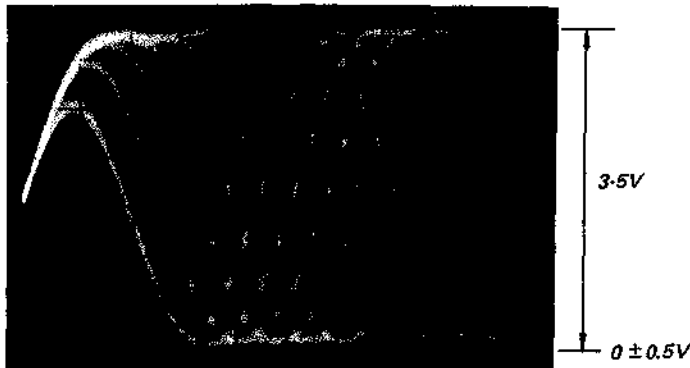

When observing the eye pattern, set the oscilloscope for AC range and raise the vertical sensitivity.

IC502 Phase Lock Adjustment

Procedure:

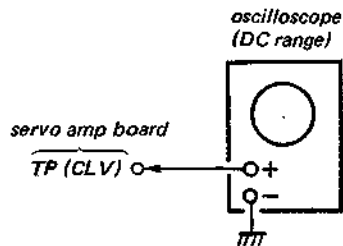

1. Turn Power switch on, insert disc (YEDS-1) and press \triangleright button.
2. Connect oscilloscope to servo amp board test point (CLV).
3. Adjust RV502 so that the waveform is as shown in the figure below.

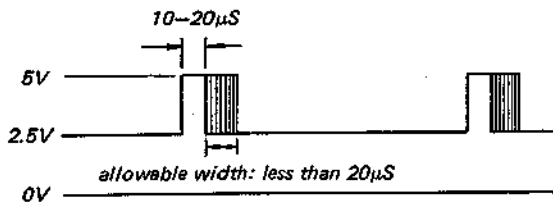

• **Incorrect Examples** *turned too far counterclockwise*



turned too far clockwise

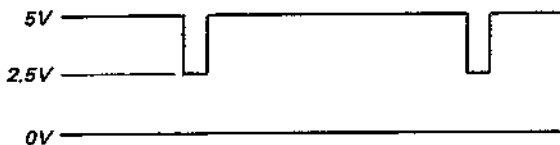

Adjustment Location: Servo amp board

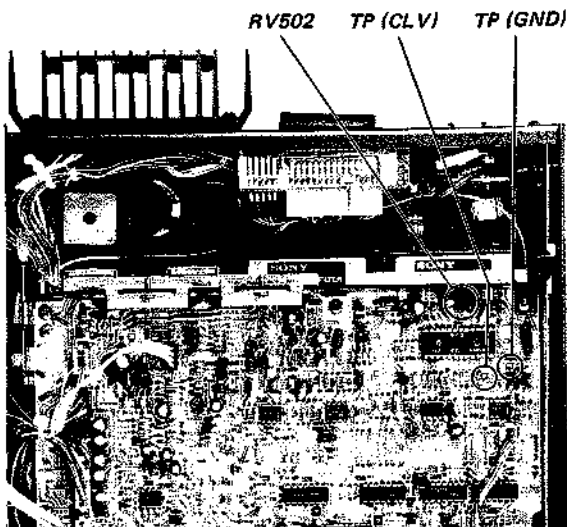

AF Offset Adjustment

Procedure:

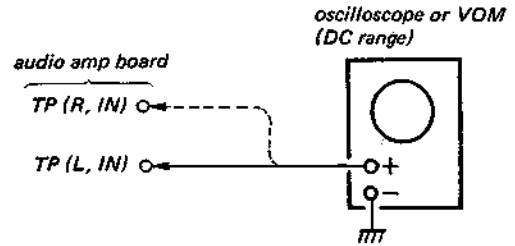

1. Turn POWER switch on. (STOP mode)
2. Connect oscilloscope or VOM to audio amp board test points (L, IN) and R, IN).
3. Adjust RV302 (L-CH) and RV402 (R-CH) so that the oscilloscope or VOM reading is DC 0V.

Adjustment Location: Audio amp board

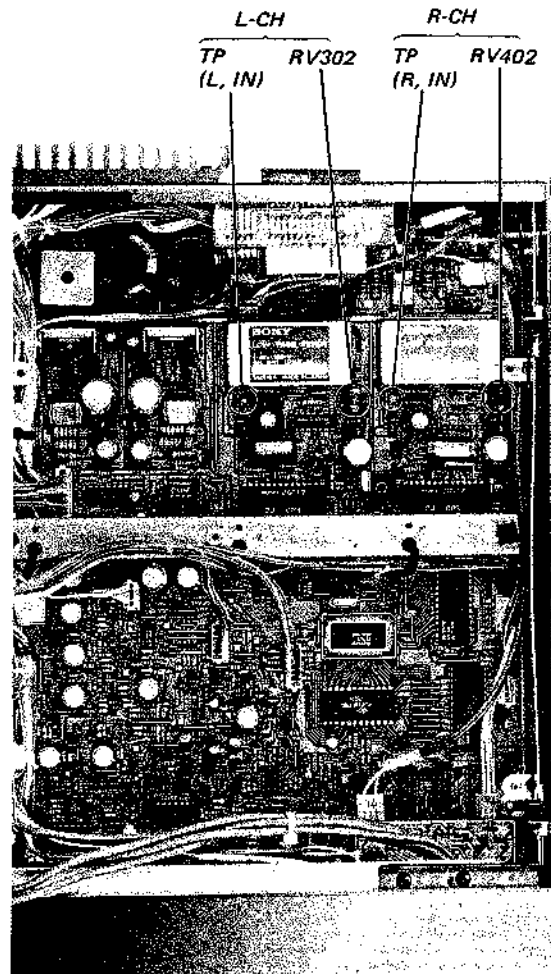

Tracking Level/Balance Adjustment

— Servo amp board —
(Conductor side)

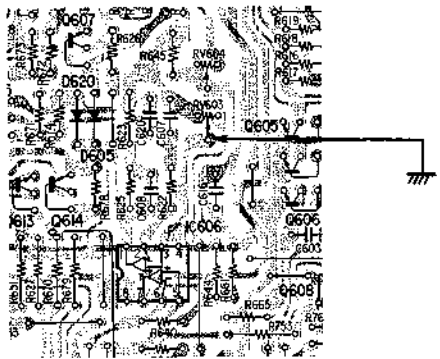

— Servo amp board —

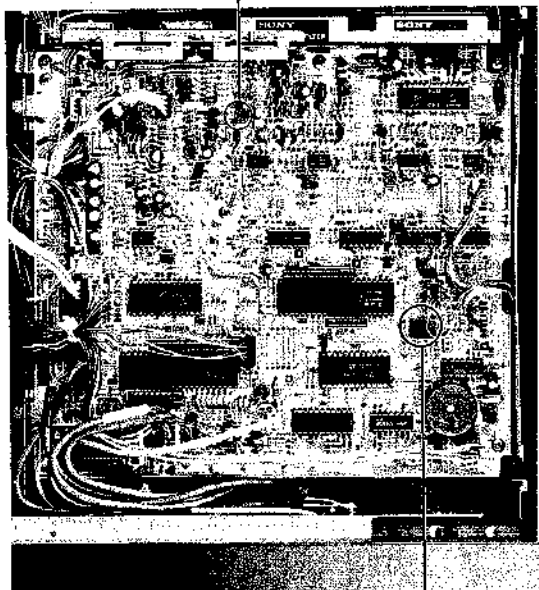

1. Put the set in adjustment mode. (Refer to page 45)
2. Ground servo board IC606 pin ③.
3. Insert the disc (YEDS-1) and press PLAY▷ button.
4. Connect the oscilloscope to the audio board test point (TE).
 - Tracking Level Adjustment —
5. Adjust RV152 for maximum peak value on the oscilloscope.
 - Tracking Balance Adjustment —
6. Adjust RV153 so that the waveform are symmetrical relative to 0V on the oscilloscope.
7. Press RESET button.
8. Read oscilloscope value.
 - When within $0 \pm 0.5V$:
Adjust RV153 so that oscilloscope reading is 0V.
 - When more than $0 \pm 0.5V$:
Adjust RV153 so that the value is half of the oscilloscope reading.
9. After adjustment, remove the lead wire grounding the servo board IC606 pin ③.

Adjustment Location: Audio amp board

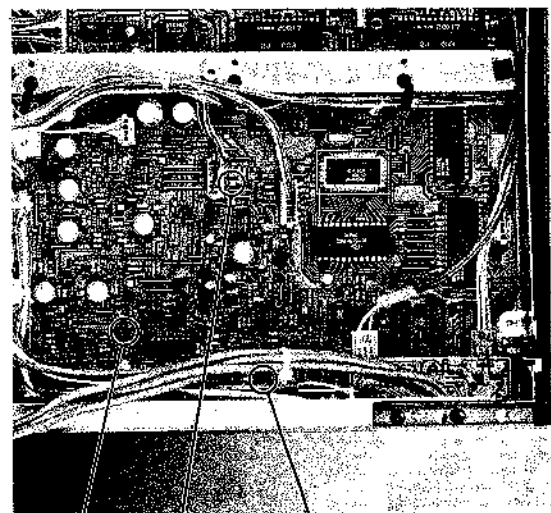

RV152
(tracking level)

TP (TE)

RV153
(tracking balance)

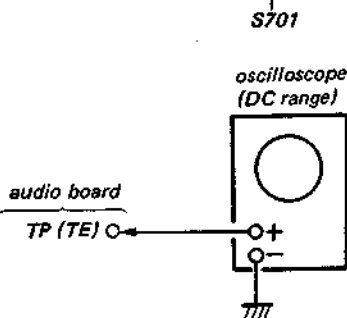

Note: Set the sweep time longer for easy waveform checking.

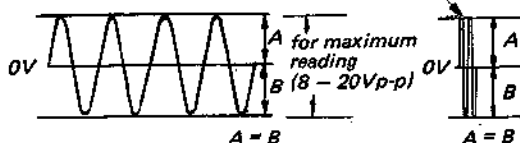

L-CH Output Level Adjustment

This adjustment is for matching up L-CH and R-CH LINE OUT output levels.

— Simple method —

Procedure:

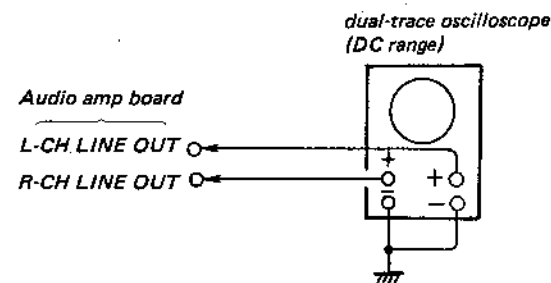

1. Remove D210 on the audio amp board and short IC301 pins (8) and (12).
2. Turn POWER switch on. (stop mode)
3. Insert the disc (YEDS-1) and press PLAY button.
4. Set a dual-trace oscilloscope as follows:
 - MODE : ADD
 - CH2 POLARITY : INVERT
 - TIME/DIV : 1mS
 - VOLTS/DIV : as small as possible
5. Connect the dual-trace oscilloscope CH1 and CH2 probes to L-CH (or R-CH) LINE OUT.
6. Adjust with the oscilloscope VOLTS/DIV VARIABLE knob so that the waveform is straight. (In order to match up dual-trace oscilloscope CH1 and CH2 sensitivity.)
7. Connect dual-trace oscilloscope CH1 and CH2 probes to L-CH and R-CH LINE OUT, respectively.
8. Adjust RV301 so that the oscilloscope waveform is straight.
9. After adjustment, remove the lead shorting IC301 pins (8) and (12), and mount D210.

● waveform adjusted
(It results in straight line)
VOLT/DIV : 50mV
TIME/DIV : 1mS



● Incorrect examples
VOLT/DIV : 50mV
TIME/DIV : 1mS



Adjustment Location: Audio amp board

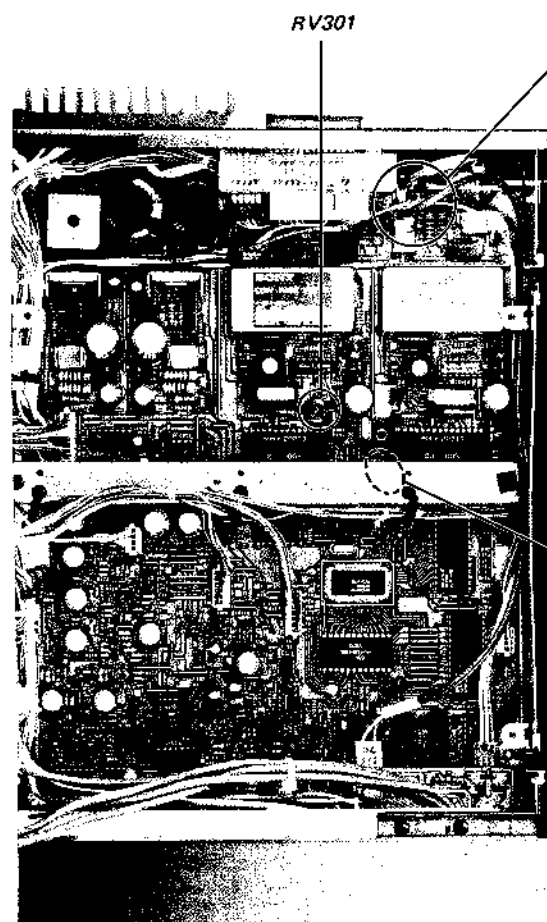

— Audio amp board (Conductor Side) —

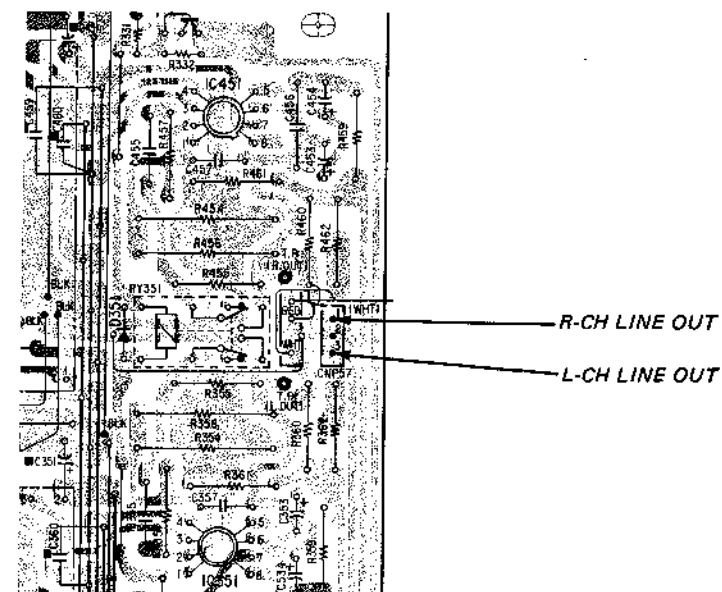

— Audio amp board (Conductor Side) —

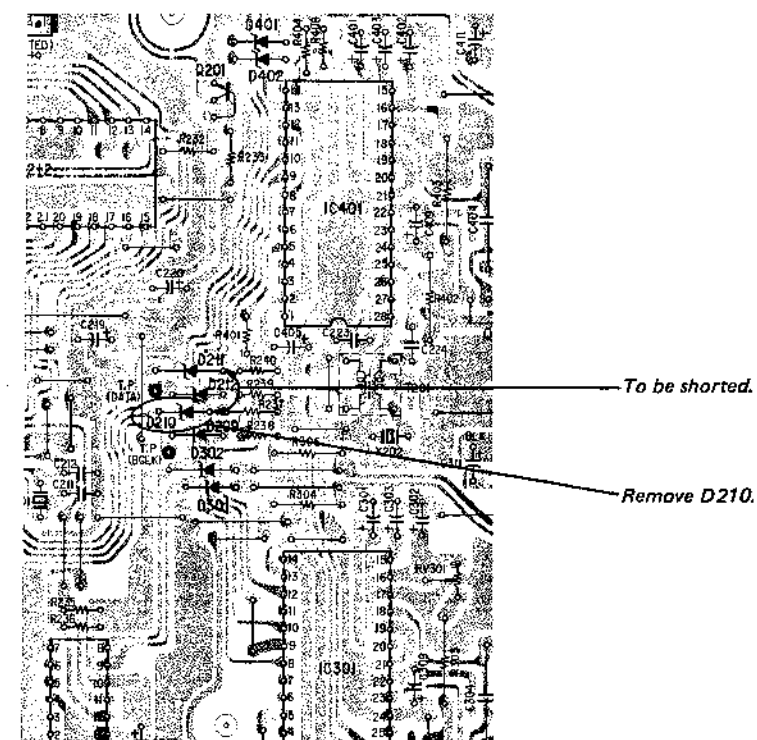

REFERENCE

Focus/Tracking Gain Adjustment

A frequency response analyzer is necessary in order to perform this adjustment exactly. However, this gain has a margin, so even if it is slightly off, there is no problem. Therefore, do not perform this adjustment. Normally, RV602 and RV603 are set in the positions shown below.

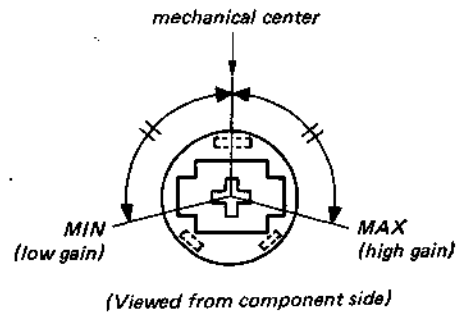

Focus/tracking gain determines the pick-up follow-up (vertical and horizontal) relative to mechanical noise and mechanical shock when the 2-axis device operates.

However, as these reciprocate, the adjustment is at the point where both are satisfied.

- When gain is raised, the noise when the 2-axis device operates increases.
- When gain is lowered, it is more susceptible to mechanical shock and skipping occurs more easily. When gain adjustment is off, the symptoms below appear.

Symptoms	Gain	Focus	Tracking
• The time until music starts becomes longer for STOP → ▷ PLAY (Normally takes about 4 seconds.)		low	low
• The time until music starts becomes longer for automatic selection (◀◀, ▶▶ buttons pressed). (Normally take about 2 seconds.)		—	low
• Music does not start and disc continues to rotate for STOP → ▷ PLAY or automatic selection (◀◀, ▶▶ buttons pressed.)		—	low

Symptoms	Gain	Focus	Tracking
• Intermittent sound is heard during the play.		low	low
• The display on the time counter does not go ahead.		—	low
• The disc compartment opens and the holding of the disc by the rim releases.		low	—
• More noise during 2-axis device operation.		high	high

The following is a simple adjustment method.

— Simple Adjustment —

Note: Since exact adjustment cannot be performed, remember the positions of the controls before performing the adjustment. If the positions after the simple adjustment are only a little different, return the controls to the original positions.

Procedure:

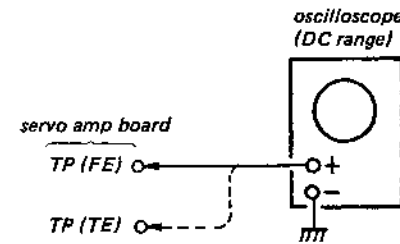

1. Keep the set horizontal. (If the set is not horizontal, this adjustment cannot be performed due to the gravity against the 2 axis device.)
2. Turn Power switch on, insert disc (YEDS-1) and press ▷ PLAY button.
3. Connect oscilloscope to servo amp board TP (FE).
4. Adjust RV602 so that the waveform is as shown in the figure below. (focus gain adjustment)

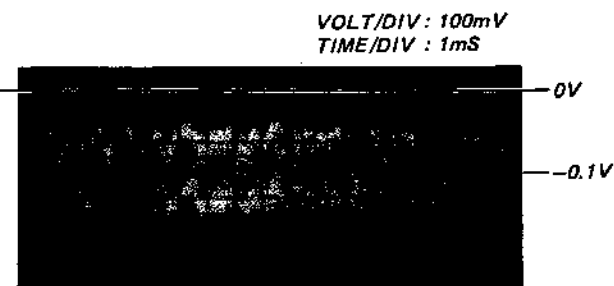

- Incorrect Examples (DC level changes more than on adjusted waveform)

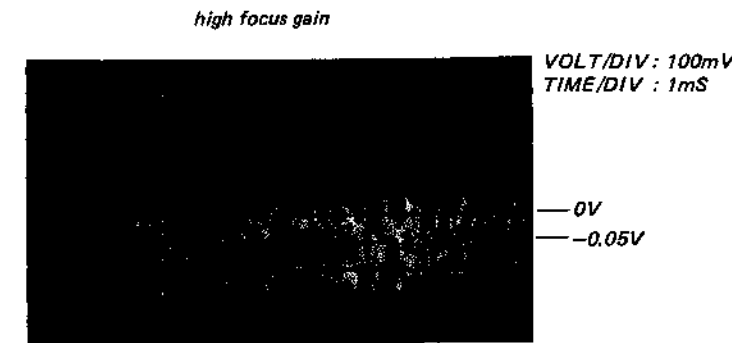
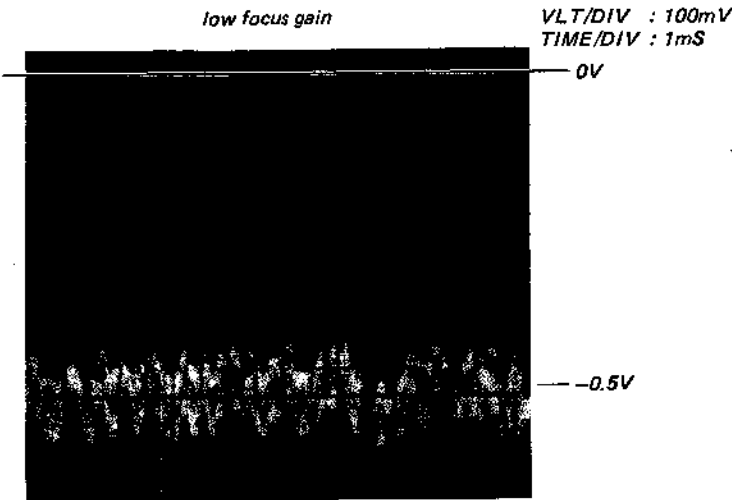

5. Connect oscilloscope to servo amp board.
6. Adjust RV603 so that the waveform is as shown in the figure below. (tracking gain adjustment)

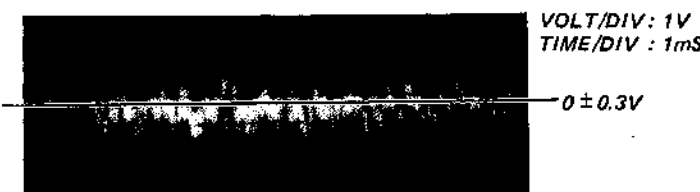

- Incorrect Examples (fundamental wave appears)

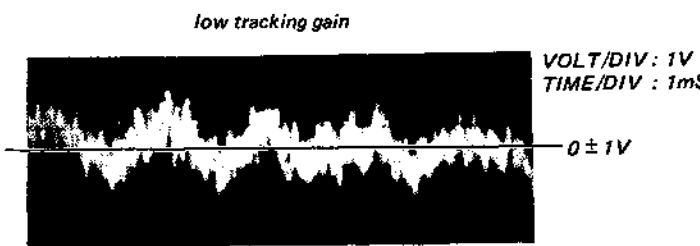

high tracking gain (higher fundamental wave than for low gain) VOLT/DIV: 1V TIME/DIV: 1mS

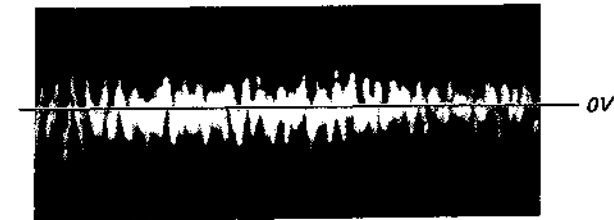

Adjustment Location: Servo amp board

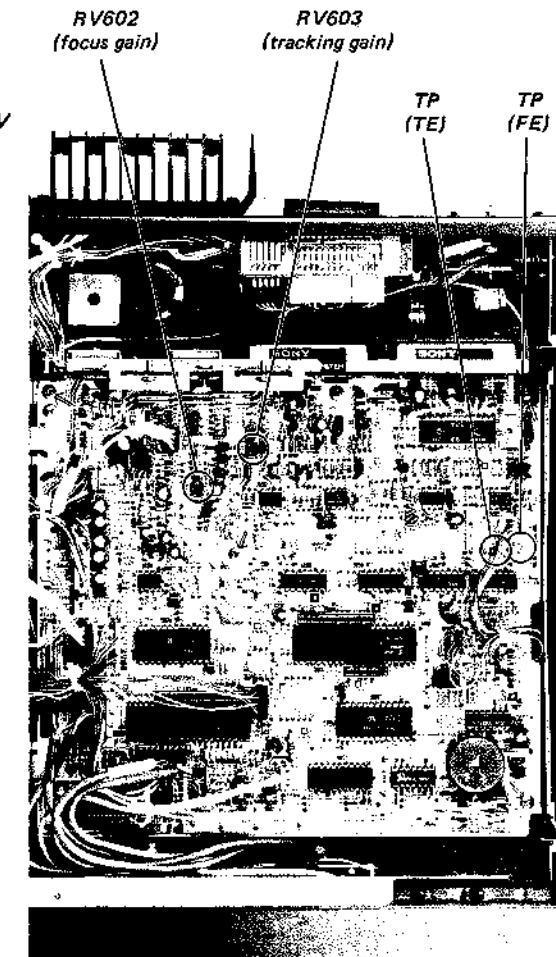

1
2
3
4
5
6
7
8
9
10

4-1. MOUNTING DIAGRAM - Audio Amp Section - - Conductor Side -

Note:

- Color code of sleeving over the end of the jacket.

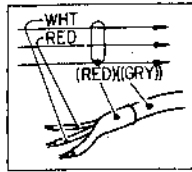

- Parts extracted from the component side.
- Parts extracted from the conductor side.
- B+ pattern.
- Signal path.
- L-CH signal path.
- R-CH signal path.
- Readings are taken under no-signal (detuned) conditions with a VOM (50 kΩ/V).
- no mark : STOP
- () : play
- Voltages and waveforms are with respect to ground by using an oscilloscope.

Q, IC	D
	401 408,406
351	402 407
IC204 201 IC451	403
IC210 IC403	
IC212	
IC205 IC401	
IC402	
IC202	404 351
	211 405 0.15μSEC
	212 4.6V-P
IC201 IC209 IC211	302
IC203	301 308,306
	307
	201 303
	203 202
	451 451
IC105 IC301	
IC154 IC213 IC302	156
	956,906
IC153	154 304
IC155, IC156 301	152, 153 305
IC101, IC102	151 160
	157 159 161
	958 957
	956,957 907
IC903	
IC152 904 951	
IC110	
IC107 IC151 952	908,958 954
106	
IC109	
IC106 905 IC904 902	904
	913
IC108 IC101-104 901	
IC901 906,907	901
IC105 908	
Q, IC	D

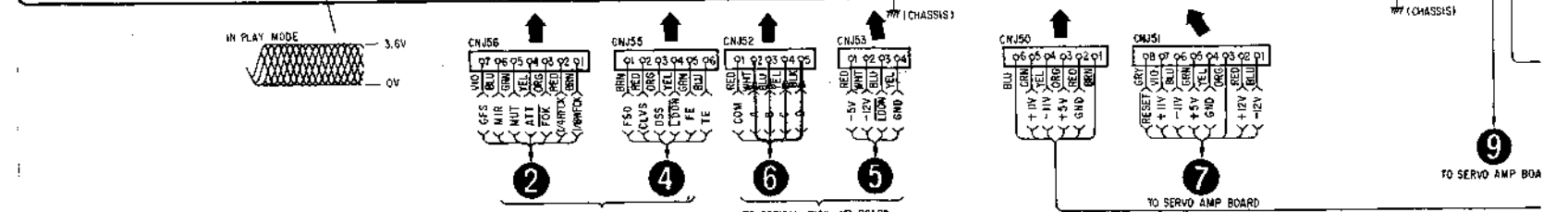
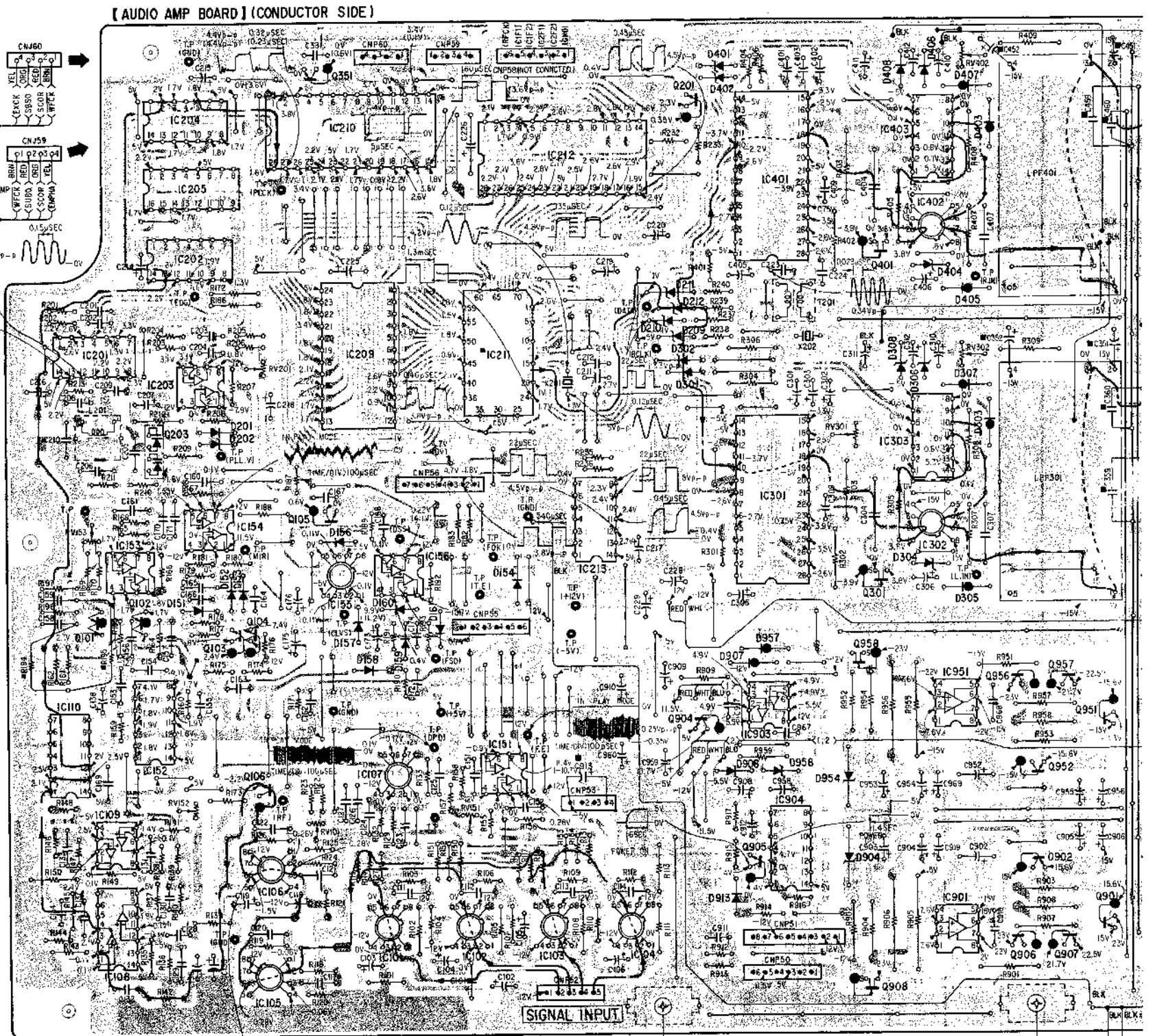

L M N O P Q R S T U V W X Y Z A1

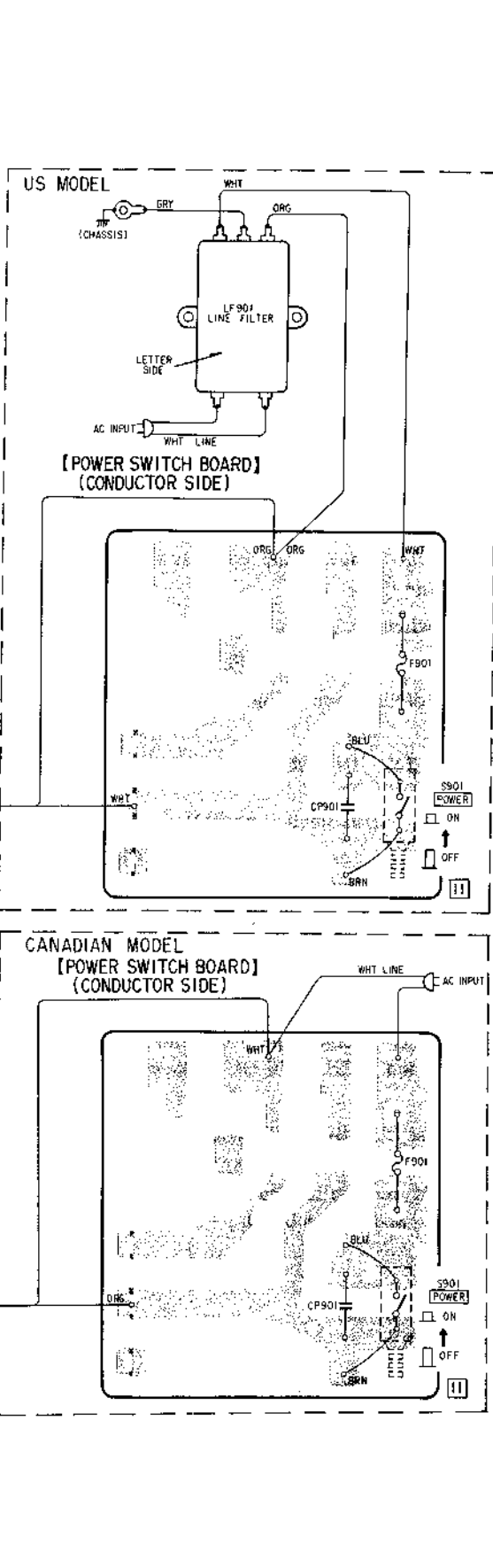
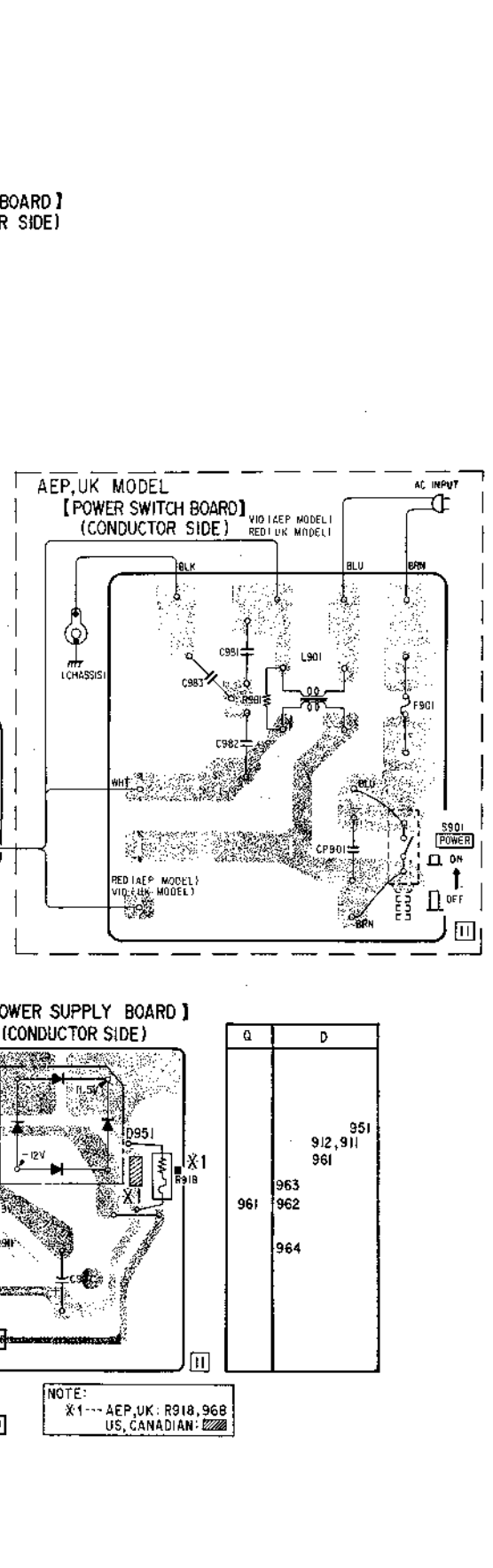
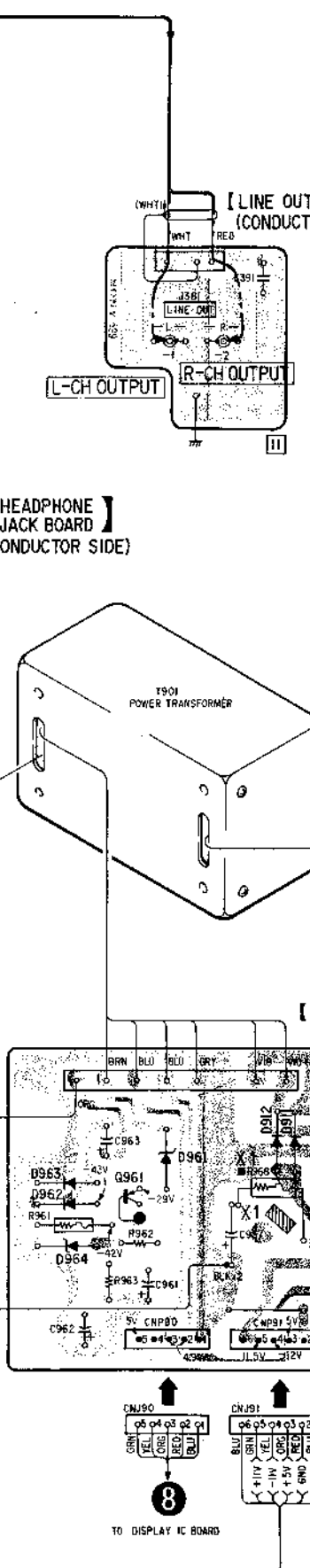
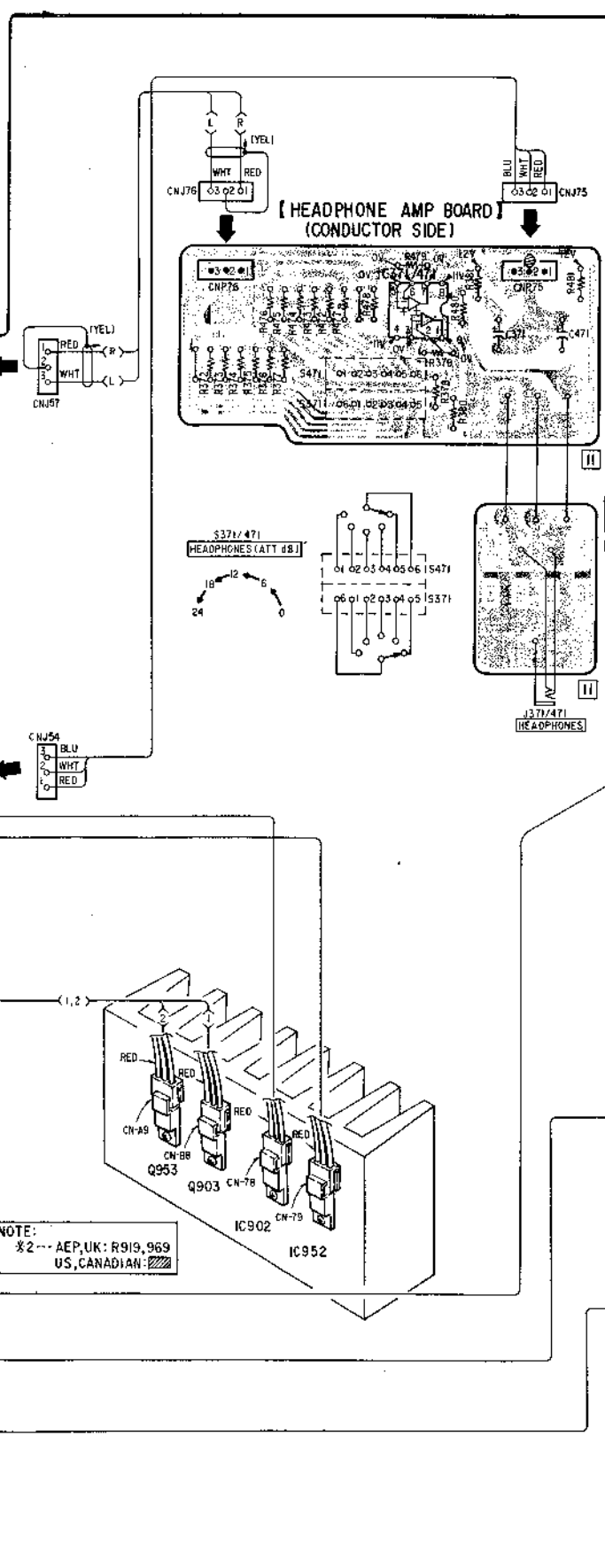
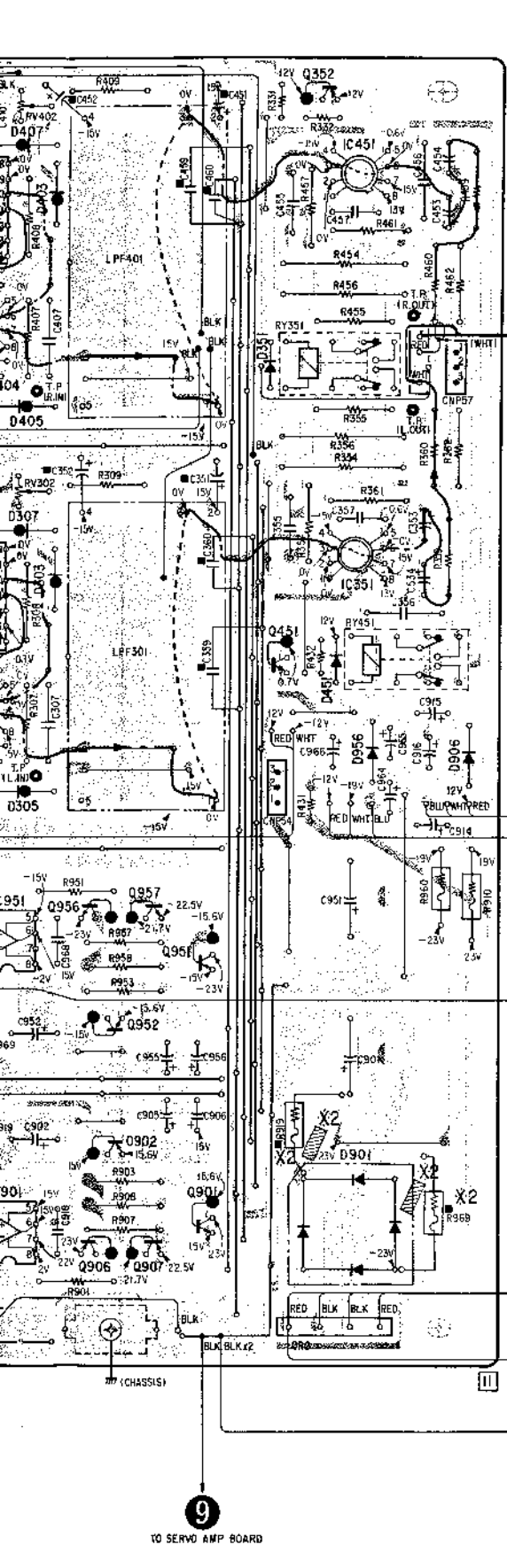

1
2
3
4
5
6
7
8
9
10

CDP-701ES CDP-701ES

4-2. SCHEMATIC DIAGRAM — Audio Amp Section —

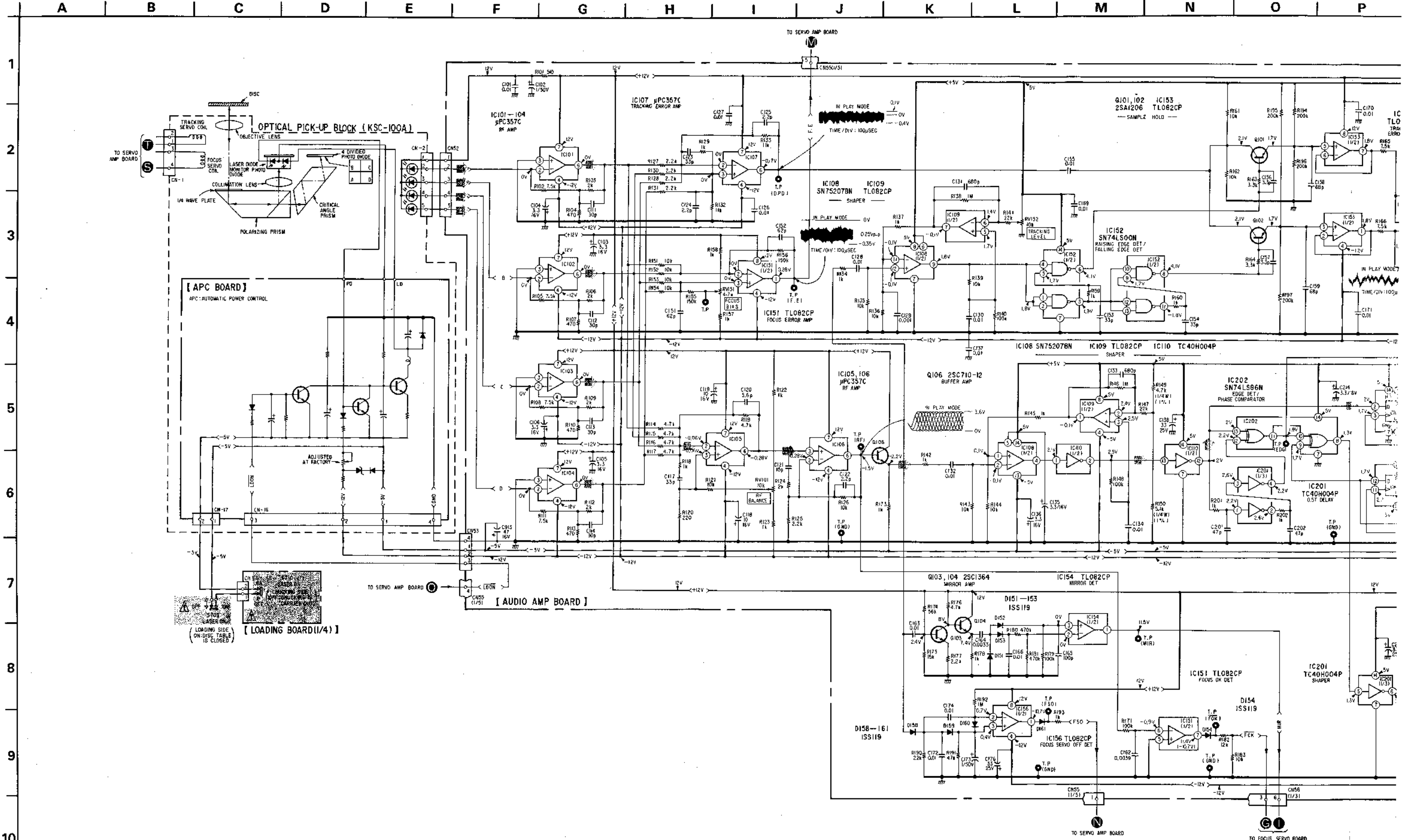

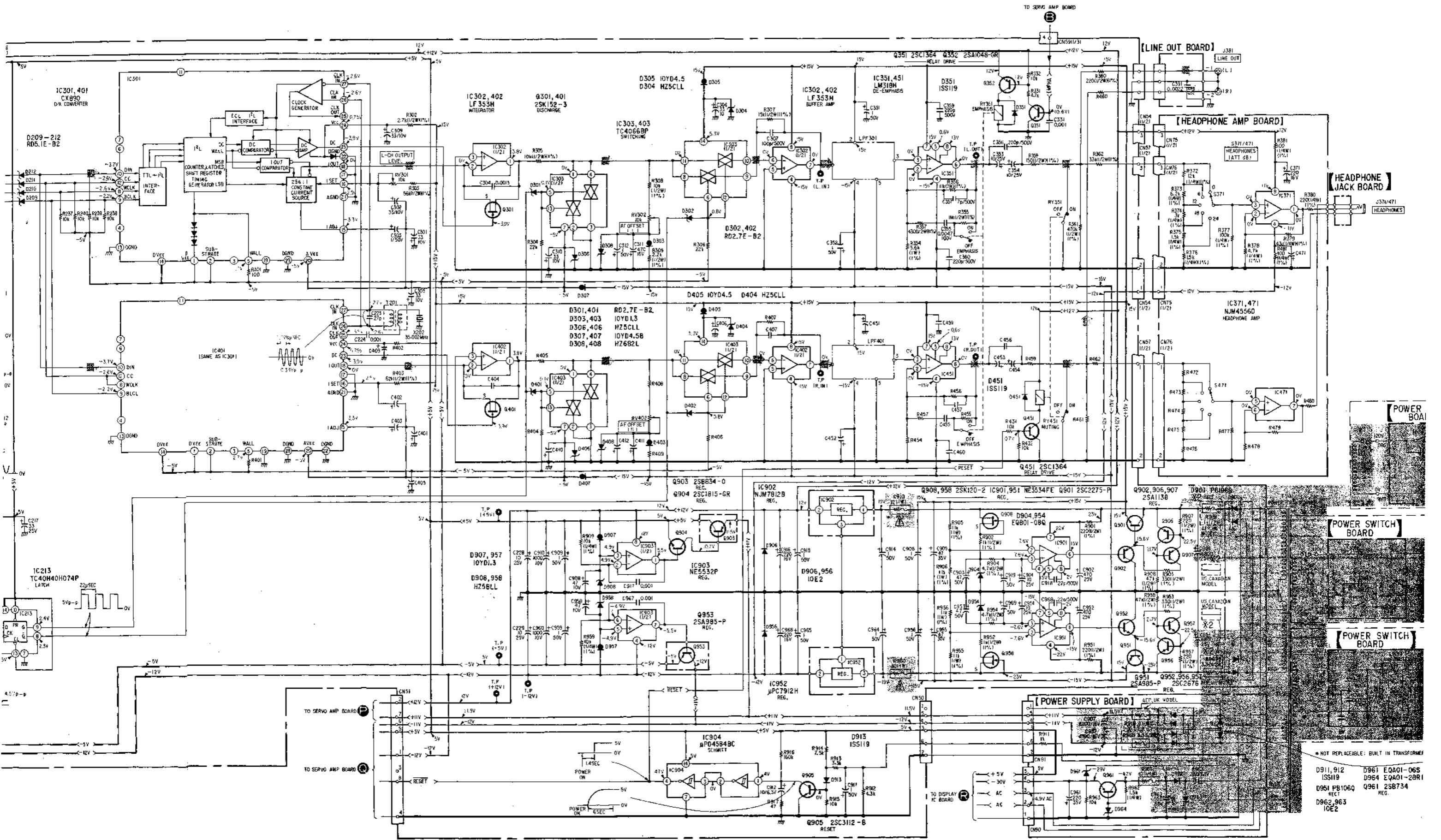

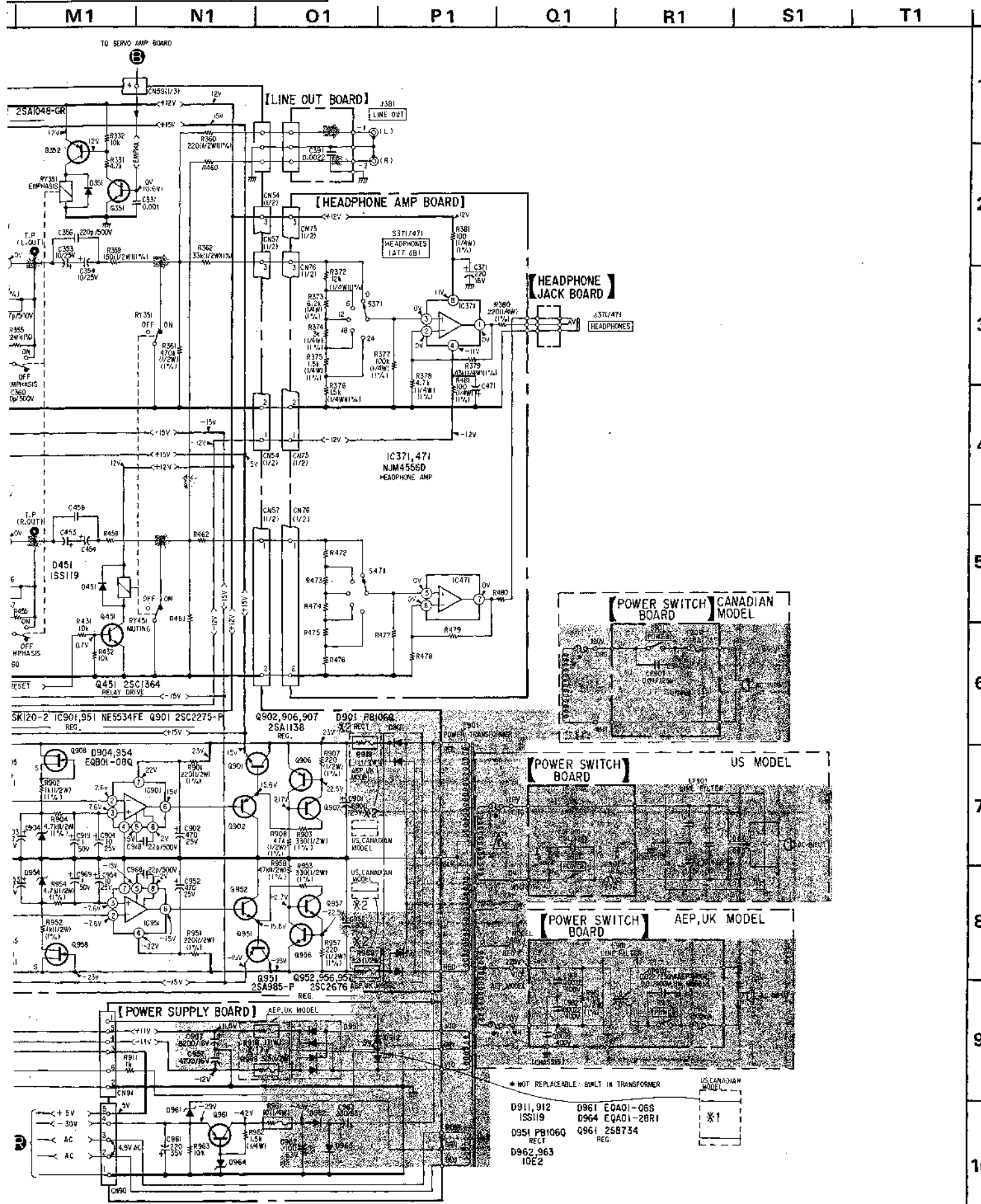

1
2
3
4
5
6
7
8
9
10

- Note:**
- Components for right channel have same values as for left channel.
 - All capacitors are in μF unless otherwise noted. $\text{pF} : \mu\mu\text{F}$ 50WV or less are not indicated except for electrolytics and tantalums.
 - All resistors are in ohms, $\frac{1}{4}$ W unless otherwise noted. $\text{k}\Omega : 1000 \Omega$, $\text{M}\Omega : 1000 \text{k}\Omega$
 - : fusible resistor.
 - : adjustment for repair.
 - : B+ bus.
 - : B- bus.
 - Readings are taken under no-signal (detuned) conditions with a VOM (50 $\text{k}\Omega/\text{V}$).
no mark : STOP
() : play
 - Voltages and waveforms are with respect to ground by using an oscilloscope.
 - : signal path
 - Switch

Ref. No.	Switch	Position
S709	LASER ON (LOADING SIDE)	ON
S710	LASER ON (CHUCKING SIDE)	ON
S901	POWER	OFF

Note: The components identified by shading and mark are critical for safety. Replace only with part number specified.

Note: Les composants identifiés par une trame et une marque sont critiques pour la sécurité. Ne les remplacer que par une pièce portant le numéro spécifié.

Note: Voltages are measured with a VOM (50 $\text{k}\Omega/\text{V}$).

4-3. SCHEMATIC DIAGRAM - Servo Amp Section -

Note:

• All capacitors are in μF unless otherwise noted. μF : $\mu\mu F$ 50WV or less are not indicated except for electrolytics and tantalums.

• All resistors are in ohms, $\frac{1}{8} W$ unless otherwise noted. $k\Omega$: 1000 Ω , $M\Omega$: 1000 $k\Omega$

• : fusible resistor.

• : adjustment for repair.

• : B+ bus.

• : B- bus.

• Readings are taken under no-signal (detuned) conditions with a VOM (50 $k\Omega/V$).

no mark : STOP

() : play

• Voltages and waveforms are with respect to ground by using an oscilloscope.

• Switch

Ref. No.	Switch	Position
S701	CLV	LOCK
S702	LIMIT	ON
S703	CHUCKING DET	ON
S704	DISC TABLE POSITION DET	CLOSE
S705	BEEP	ON
S706	TIMER	OFF
S707	CHUCKING MOTOR	ON
S708	MOTOR SELECT	CHUCKING
S711	OPEN/CLOSE	OFF
S851	▷ (PLAY)	OFF
S852	⏸ (PAUSE)	OFF
S853	1	OFF
S854	ALL	OFF
S855	MEMORY A → B } REPEAT	OFF
S856	CLEAR	OFF
S857	◀◀	OFF
S858	◀	OFF
S859	▶	OFF
S860	▶▶	OFF
S861	▶▶	OFF
S862	▶▶	OFF
S863	RESET	OFF
S864	MUSIC SCAN	OFF
S871	1	OFF
S872	2	OFF
S873	3	OFF
S874	4	OFF
S875	5	OFF
S876	6	OFF
S877	7	OFF
S878	8	OFF
S879	9	OFF
S880	0	OFF
S881	RMS	OFF
S882	TRACK	OFF
S883	CLEAR	OFF
S884	MIN/SEC	OFF
S885	LOCATION	OFF
S886	TRACK	OFF
S887	INDEX	OFF
S888	START	OFF

Note: The components identified by shading and mark are critical for safety. Replace only with part number specified.

Note: Les composants identifiés par une trame et une marque sont critiques pour la sécurité. Ne les remplacer que par une pièce portant le numéro spécifié.

Note: Voltages are measured with a VOM (50 $k\Omega/V$).

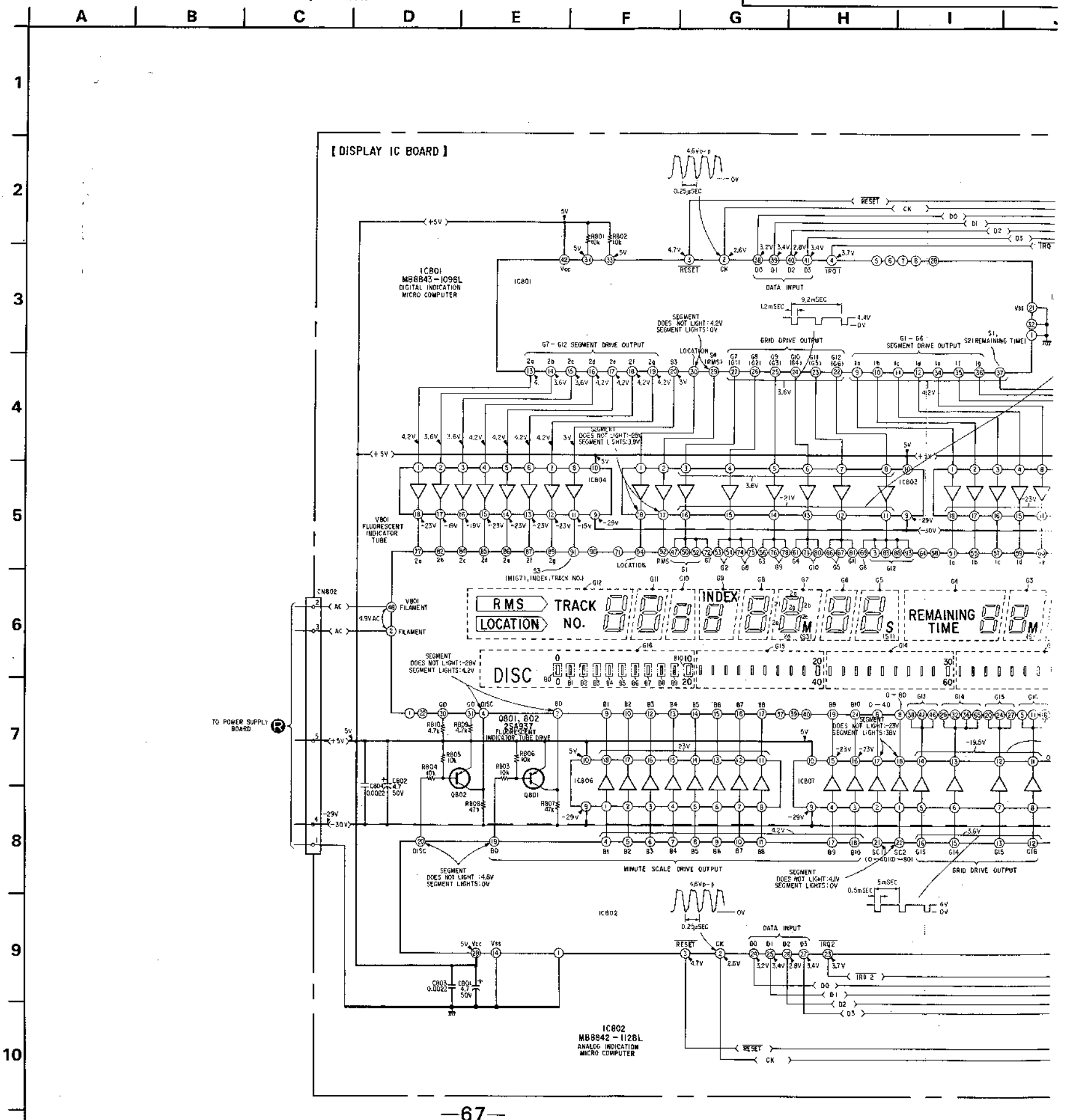

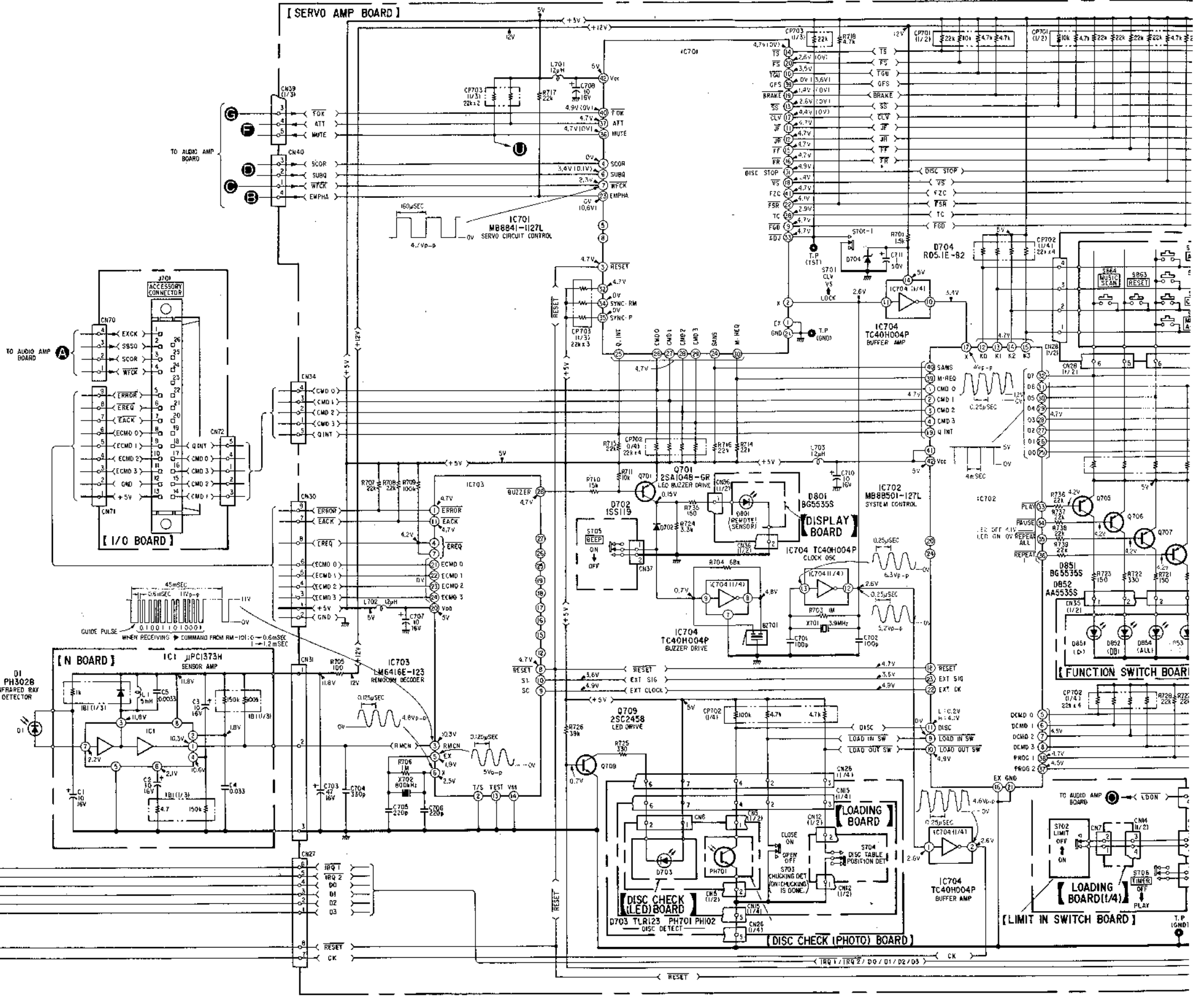
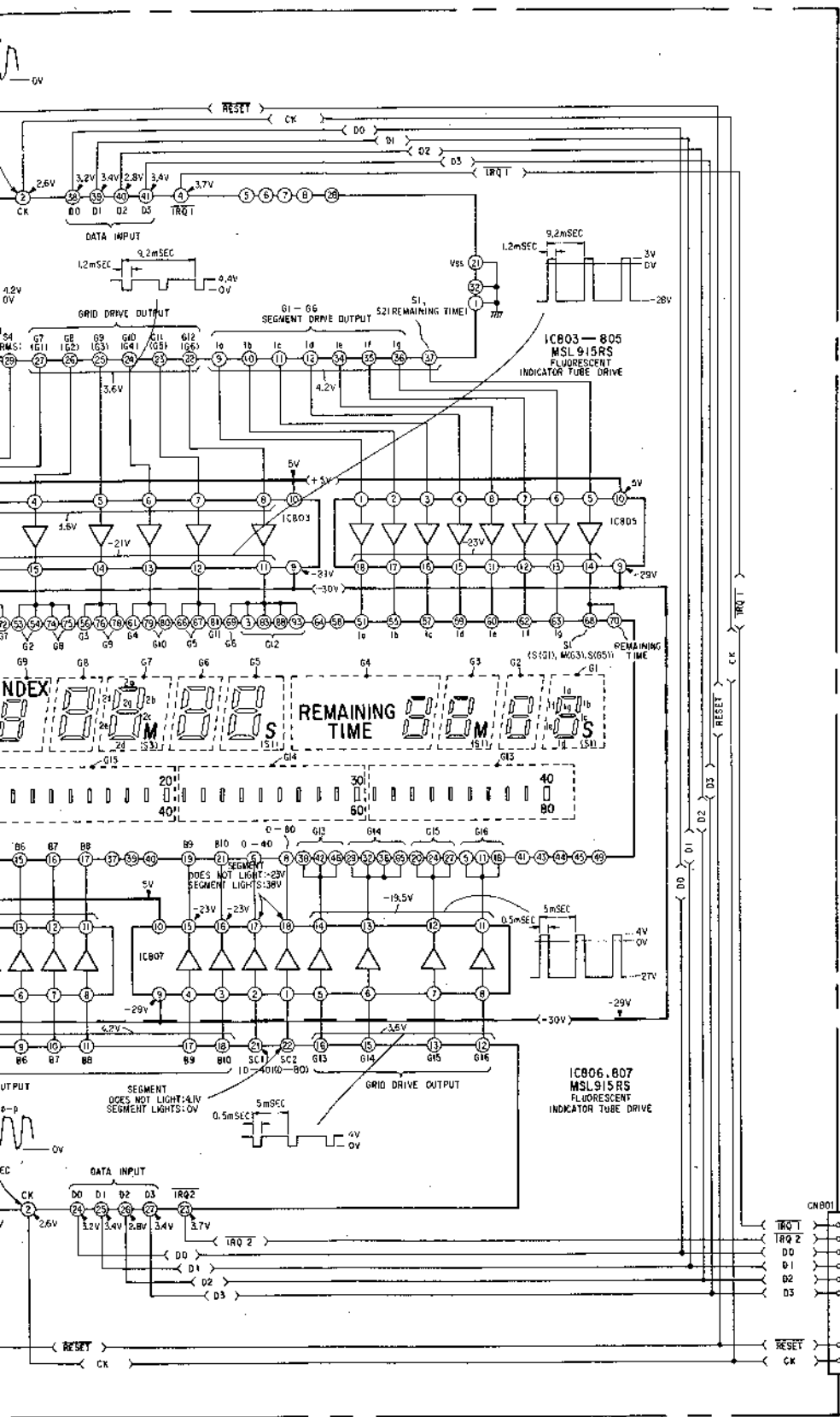

CDP-701ES CDP-701ES

Q R S T U V W X Y Z A1 B1 C1 D1 E1 F1 G1

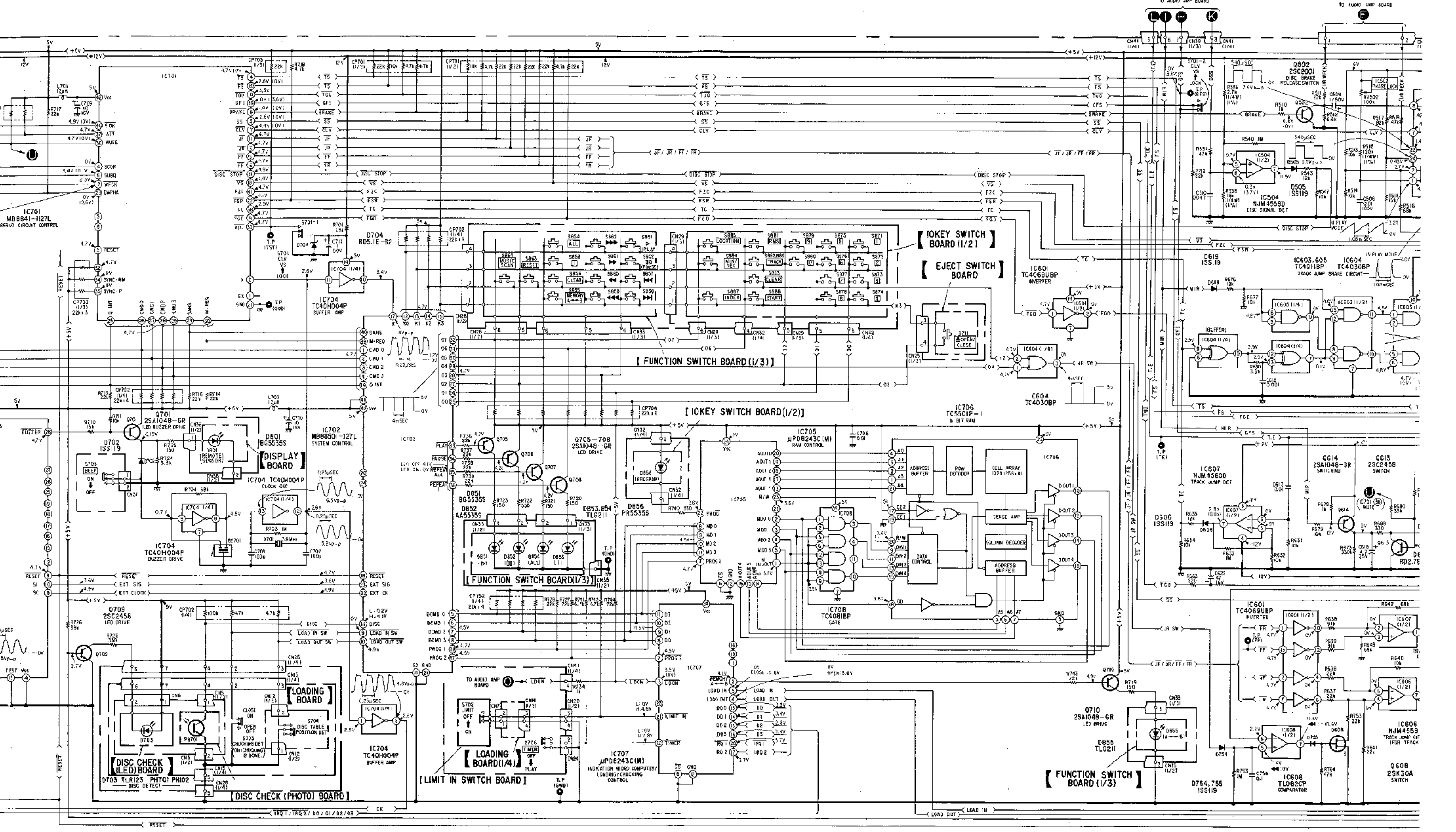

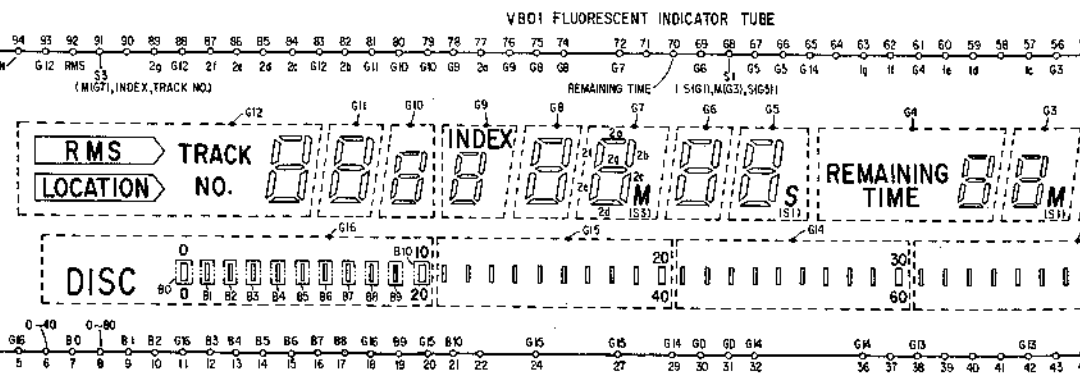
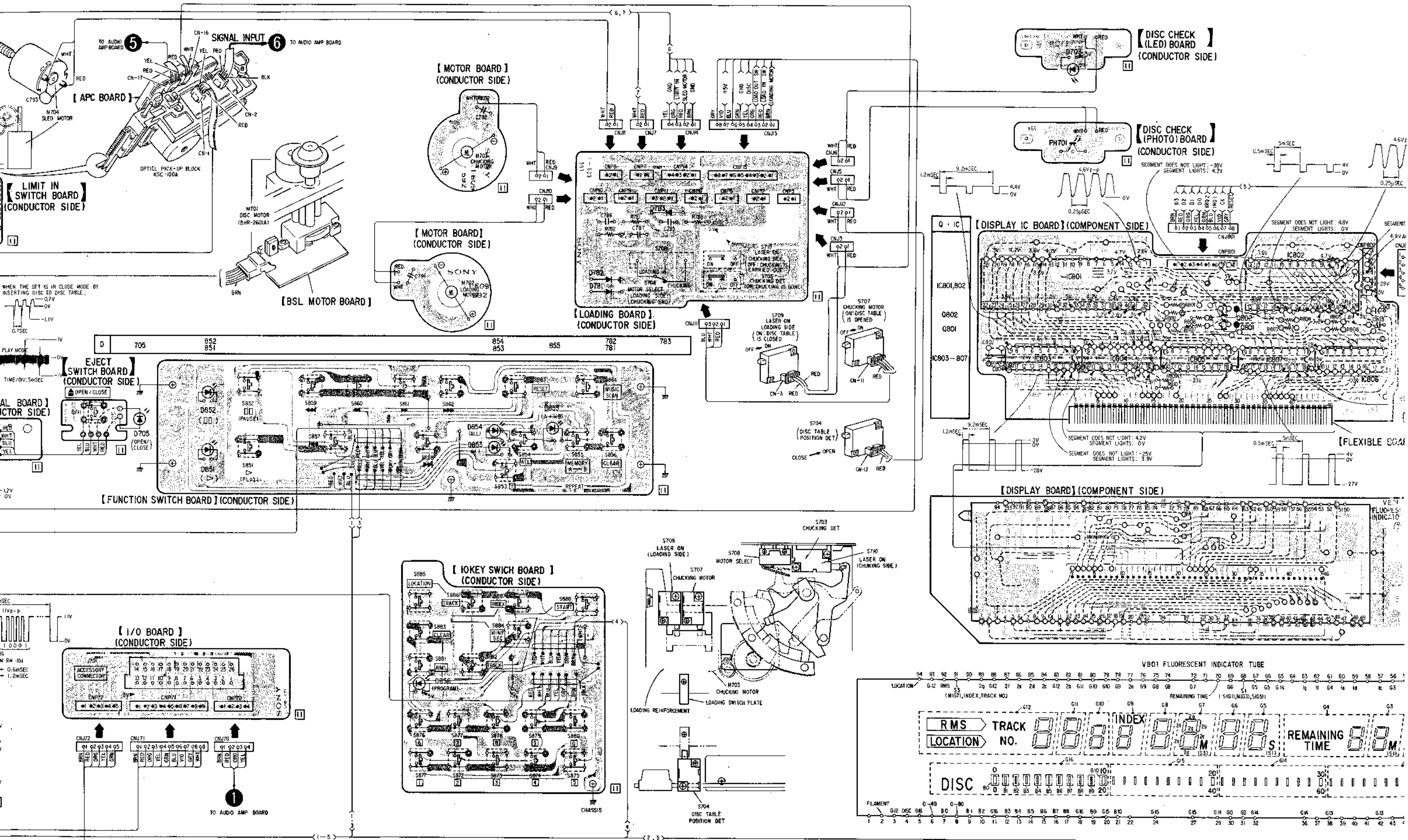

T U V W X Y Z A1 B1 C1 D1 E1

1
2
3
4
5
6
7
8
9
10

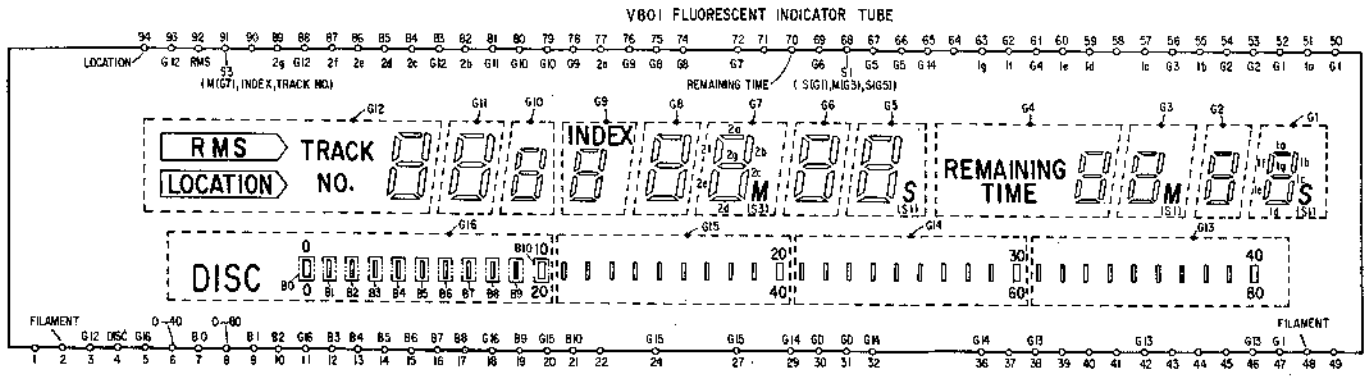
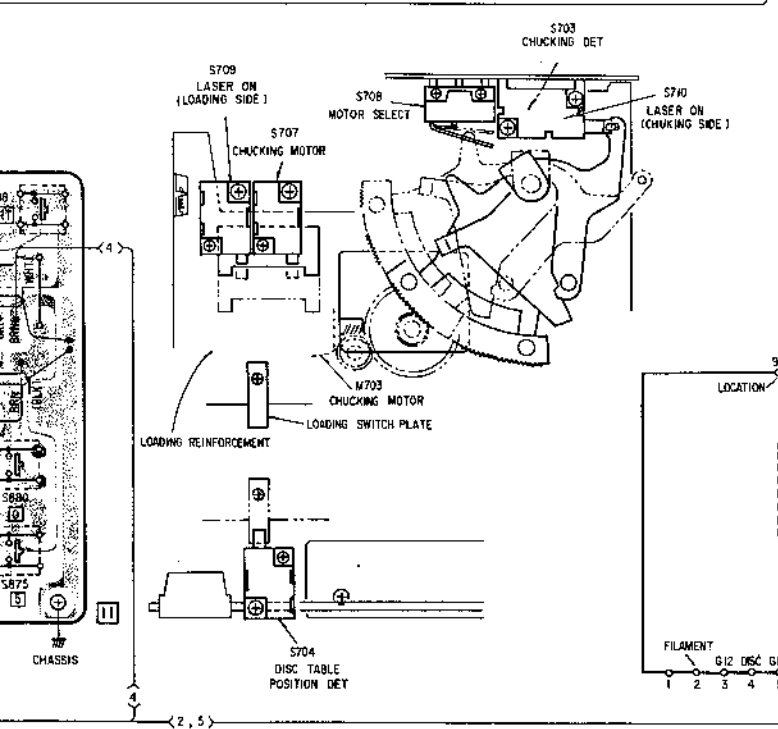
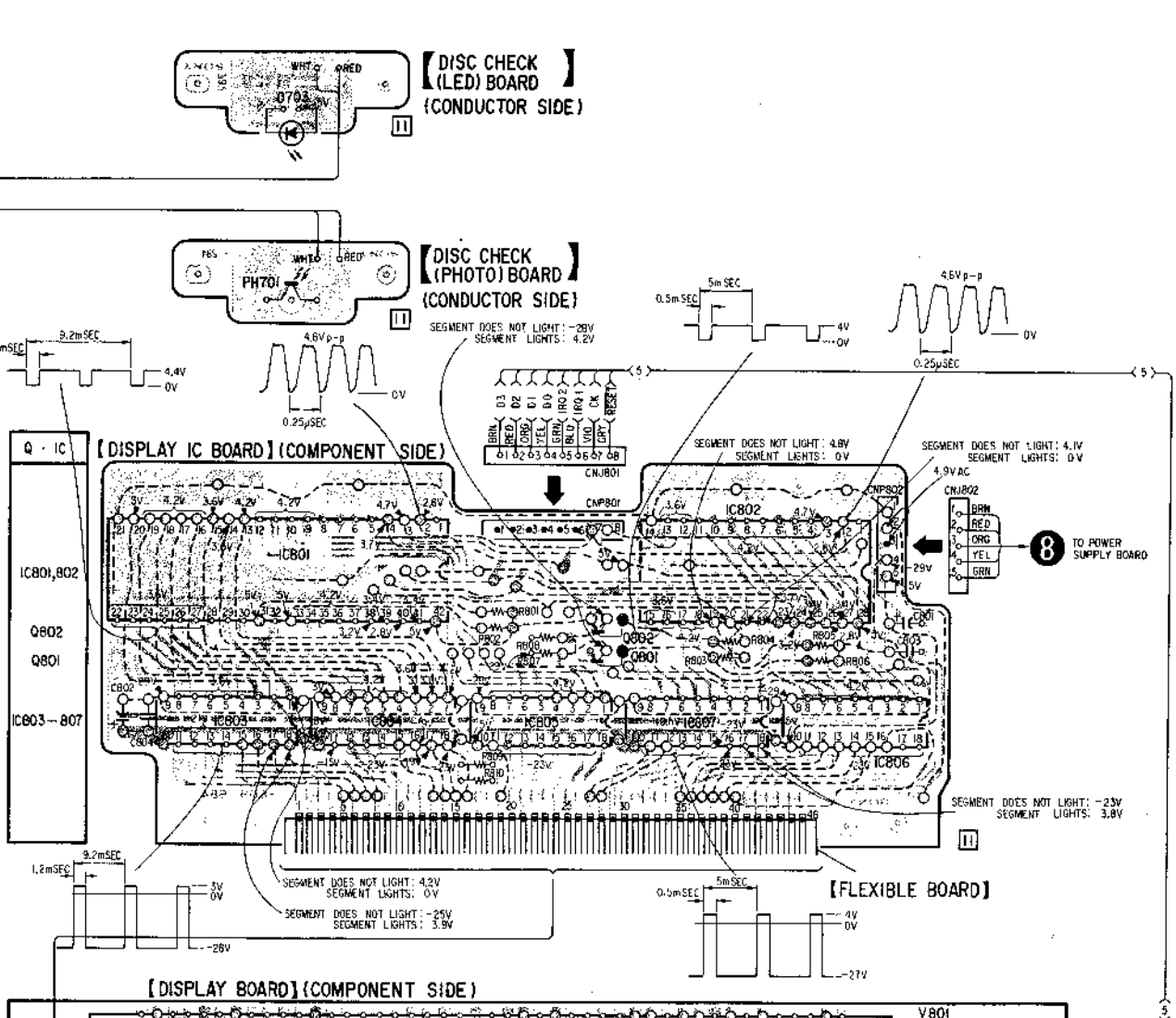
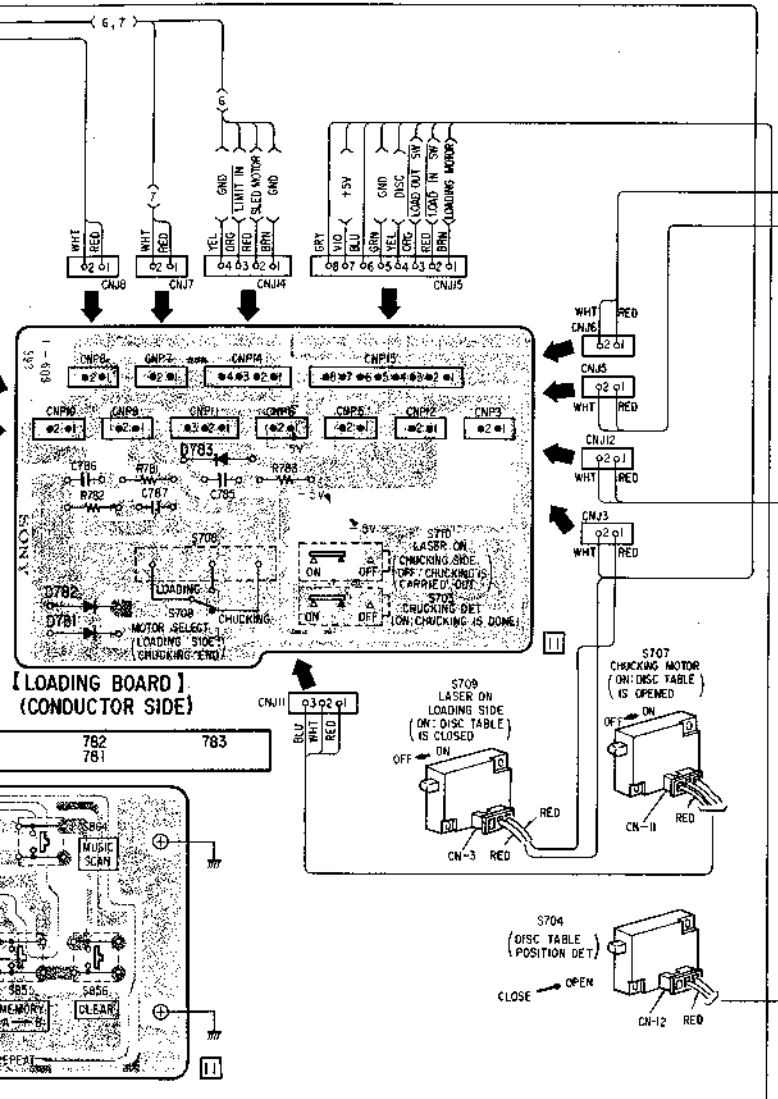

- Note:**
- Color code of sleeving over the end of the jacket.
-
- ○ : parts extracted from the component side.
 - ● : parts extracted from the conductor side.
 - ■ : part mounted on the conductor side.
- component-side pattern.
- ○ : Through hole.
 - ■ : B + pattern
- Readings are taken under no-signal (detuned) conditions with a VOM (50 kΩ/V).
 - no mark : STOP
 - () : play
 - Voltages and waveforms are with respect to ground by using an oscilloscope.

SEMICONDUCTOR LEAD LAYOUTS

CX20017
CX7933
CX7935
LM6416E-123
MSL915RS
MSM512B-12RS
NE5532P
NE5534FE
NJM4558D
NJM4560D
SN74LS00N
SN74LS74AN
SN74LS76AN
SN74LS86N
SN75207BN
TC4011BP
TC4030BP
TC4066BP
TC4069UBP
TC4081BP
TC40H004P
TC40H074P
TC5501P-1
TL082CP
 μ PC4558C
 μ PD4584BC
 μ PD8243C(M)

(Top view)

MB8841-1127L
MB8842-1128L
MB8843-1096L
MB88501-127L

(Top view)

CX193

(Top view)

μ PC1373H

μ PC7812H

μ PC7912H

CX7934

STK6922

LF353H
 μ PC357C

(Bottom view)

10E2
10YD1.3
10YD4.5
10YD4.5B
1SS119
EQA01-06S
EQA01-28R1
EQB01-08Q
HZ5BLL
HZ5CLL
HZ6B2L
HZ9C2L
RD2.7E-B1
RD2.7E-B2
RD5.1E-B2

PH302B

TLR123

AA5535S
BG5535S
PR5535S

PR2434D

KV1226-F

PB102F

TLG211

2SK30A

2SK152-3

2SA1206
2SC1364
2SC1775-F
2SC1815-GR
2SC2001
2SC3112-B

2SK120-2

2SA1048-GR
2SC2458

2SA985-P
2SB834-O
2SC2275-P

2SA1138
2SB734
2SC2676

2SA937

PH102

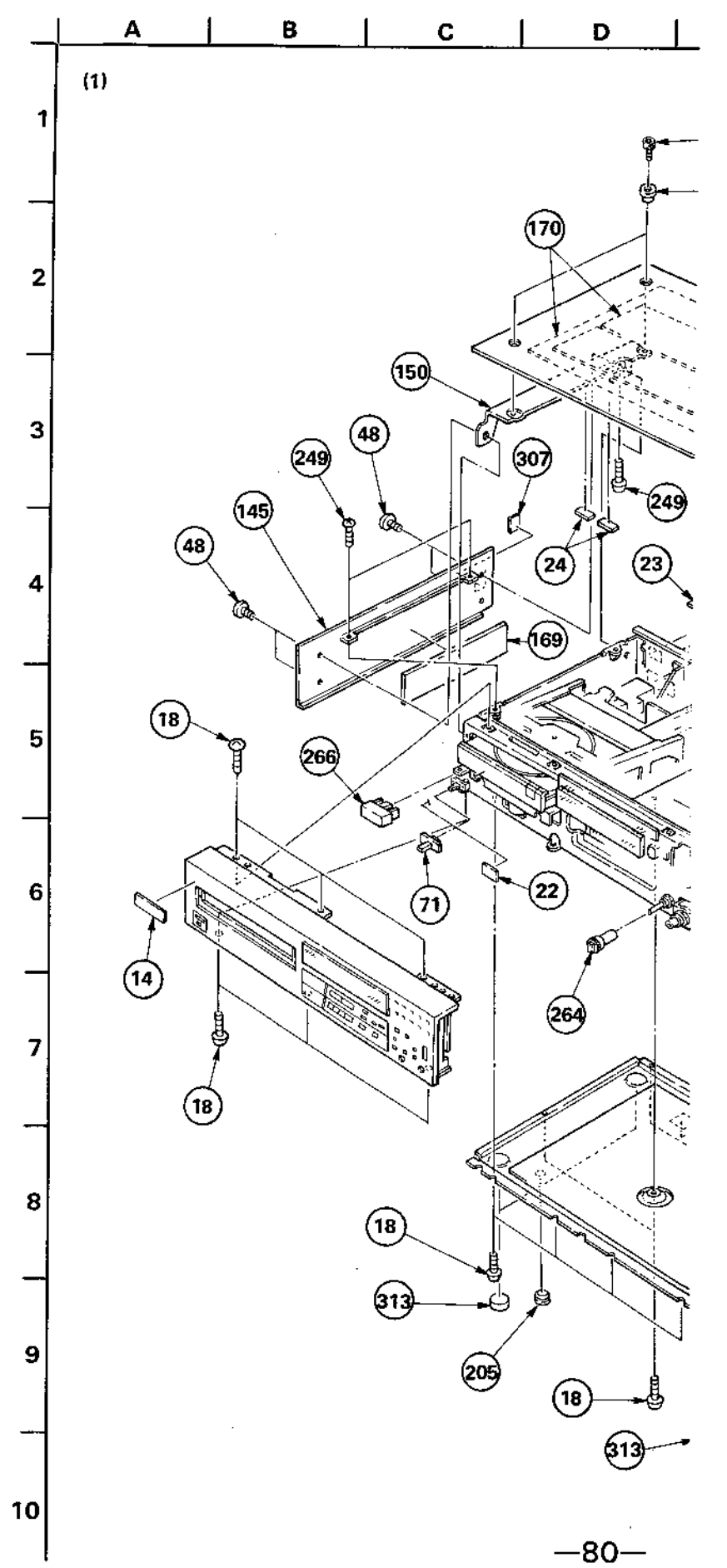

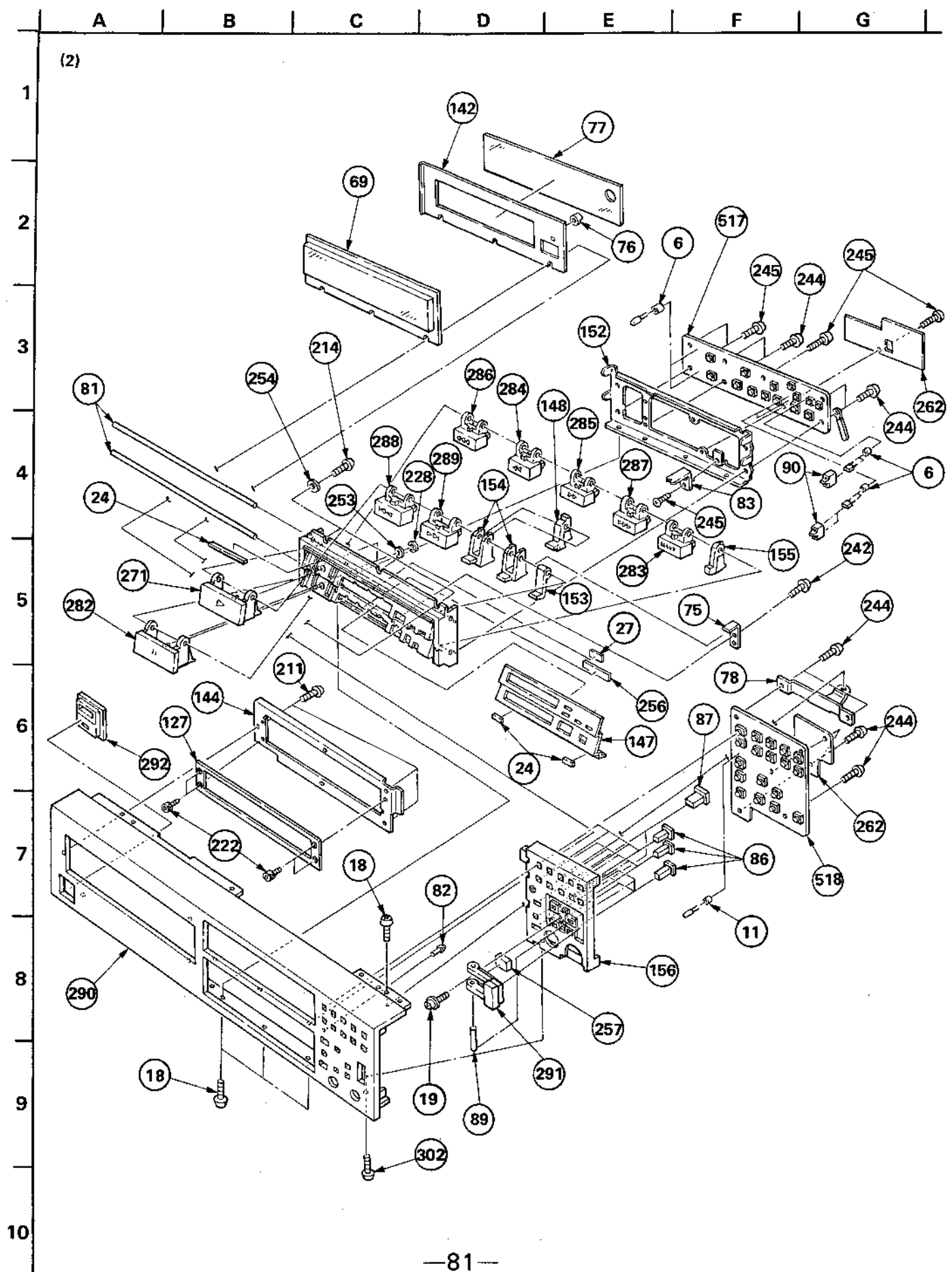
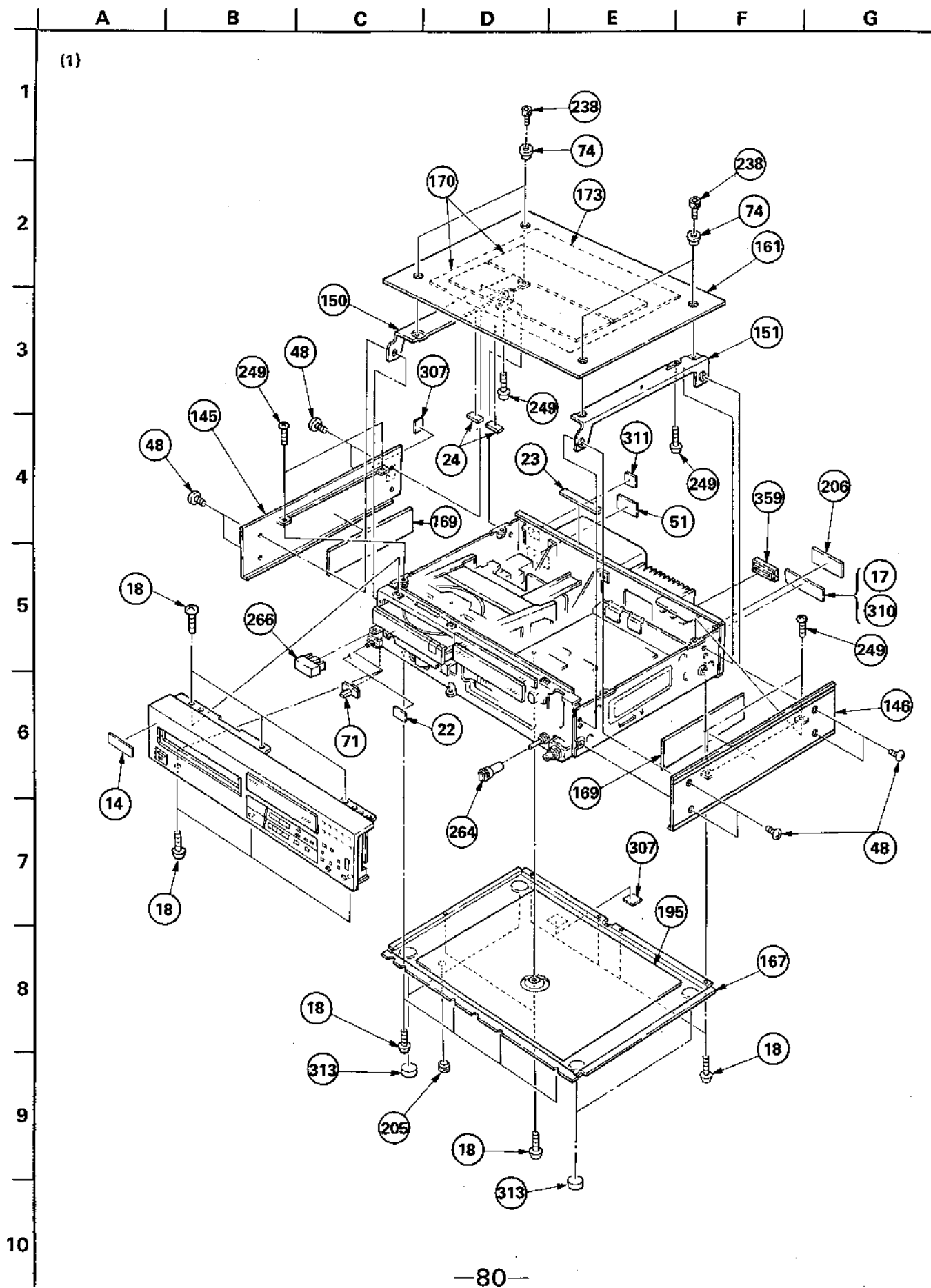

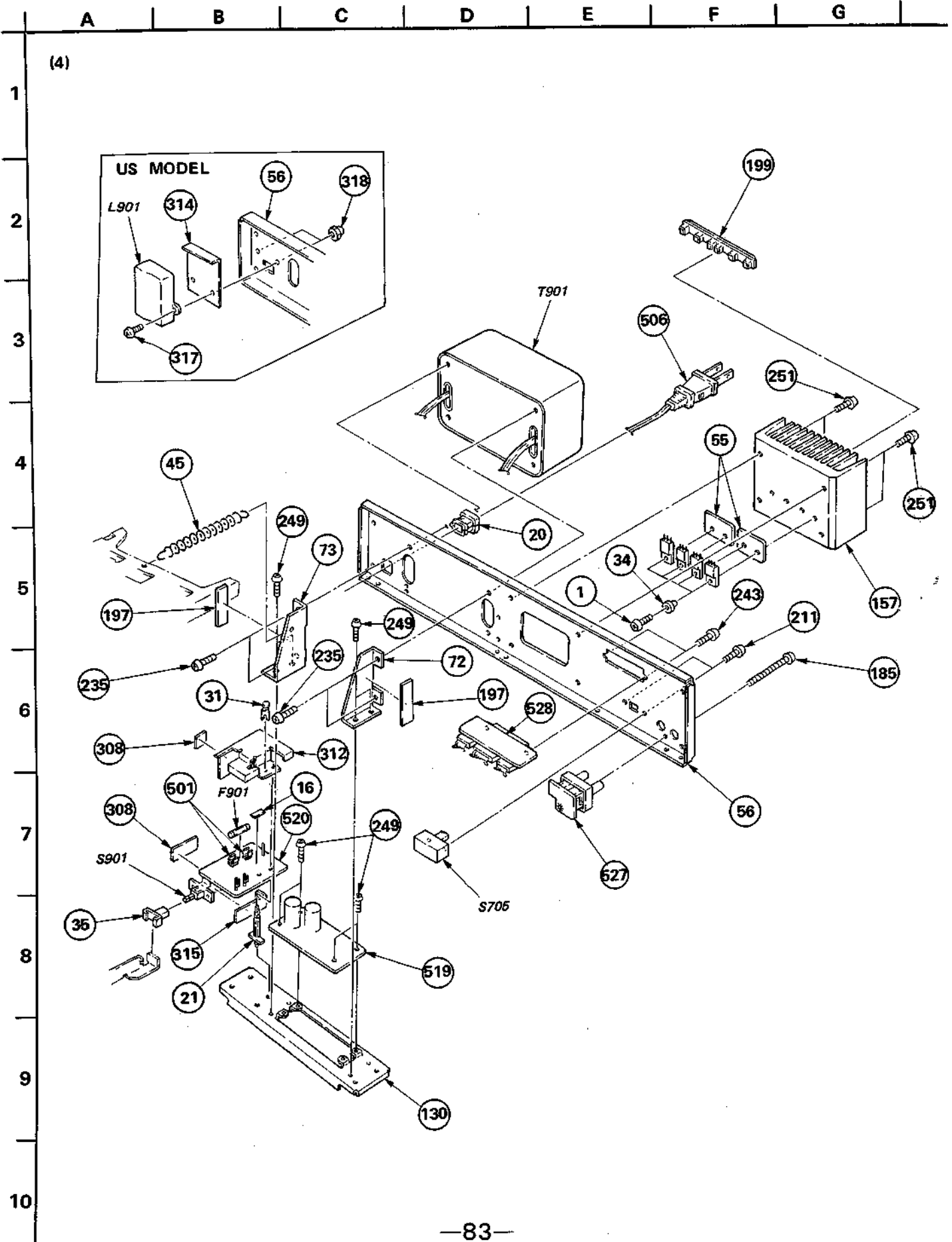

CDP-701ES

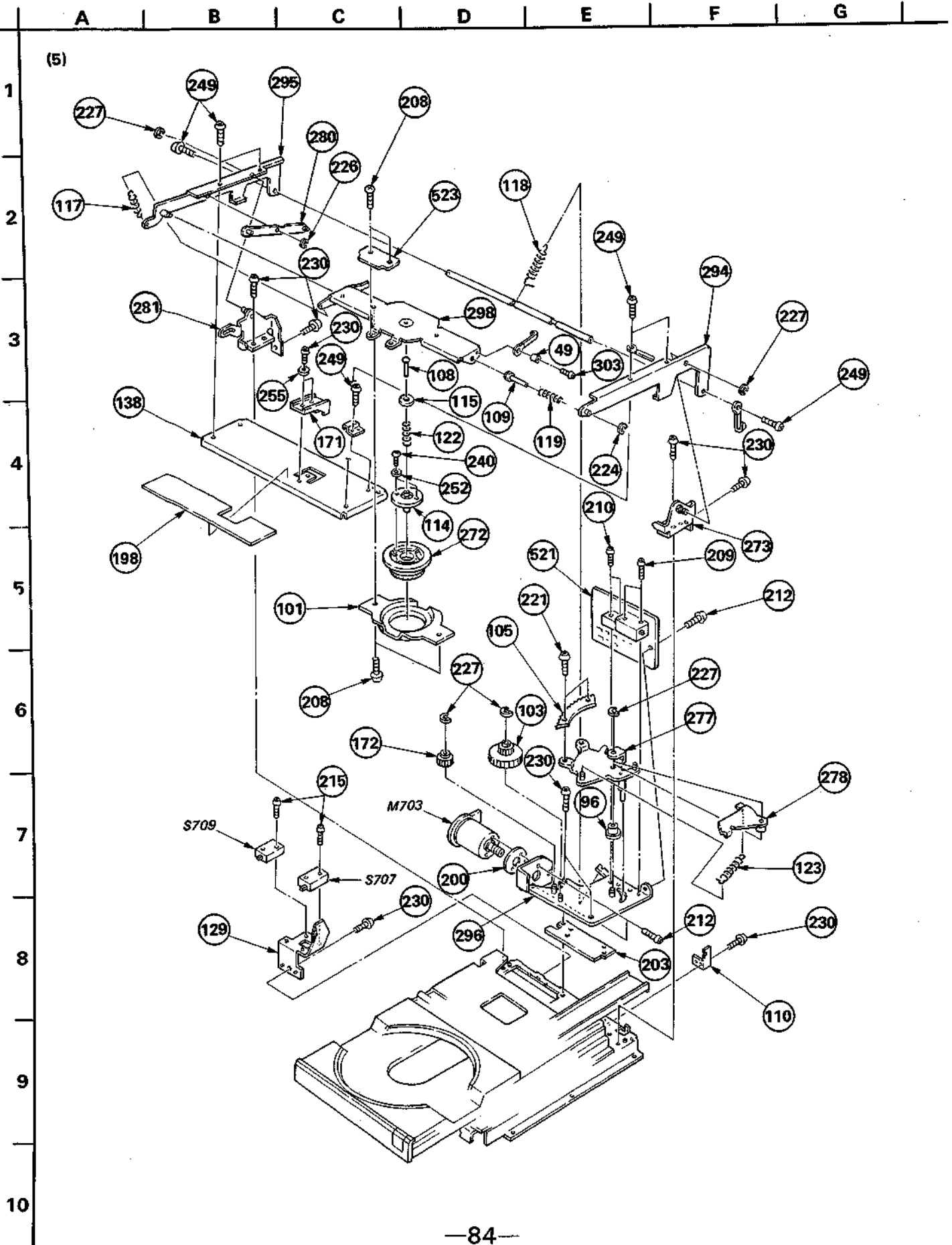

CDP-701ES

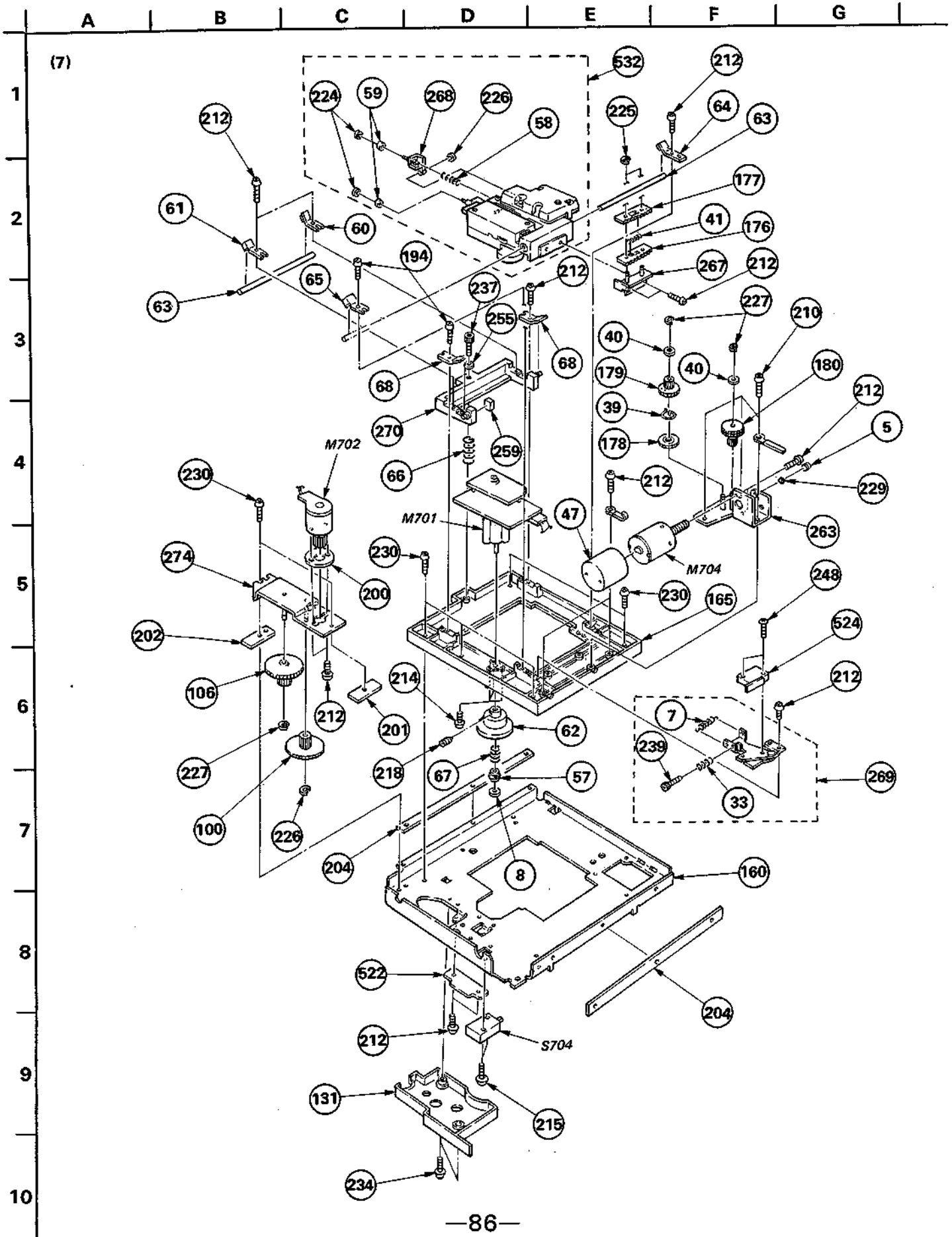

GENERAL SECTION

No.	Part No.	Description
1	2-259-121-11	SCREW, TR
2	2-269-798-01	HEAT SINK, TO-39
3	2-269-798-11	HEAT SINK, TO-39
4	♣;3-423-147-00	SPACER (DIA.6)
5	3-489-073-00	SCREW, THRUST
6	♣;3-537-790-41	REST, ARM, TENSION
7	3-548-124-00	SPRING, TENSION
8	3-558-708-21	WASHER, STOPPER
9	
10	
11	3-579-051-00	RUBBER (A)
12	3-701-439-11	WASHER
13	3-701-441-21	WASHER
14	3-701-690-00	(UK)...LABEL (MADE IN JAPAN)
15	♣;3-701-832-00	HINGE, CIRCUIT BOARD
16	♣;3-701-946-22	(US,Canadian)...LABEL, FUSE
16	♣;3-701-948-13	(AEP,UK).....LABEL, FUSE
17	3-703-043-21	(UK,Canadian)...LABEL, CAUTION, MAIN
17	♣;3-703-678-00	(US).....LABEL, CAUTION, NEW UL
18	3-703-108-21	SCREW +BV 3X6, S TIGHT
19	3-703-135-00	SCREW, TAPPING
20	3-703-244-00	BUSHING, CORD
21	♣;3-703-353-07	SUPPORT, PC BOARD
22	3-703-709-41	STICKER, SONY SYMBOL (15)
23	3-885-232-00	CUSHION (F)
24	3-831-441-XX	SPACER
25	
26	3-886-569-00	TUBE, RUBBER
27	♣;4-307-528-00	CUSHION, LAMP
28	♣;4-342-117-00	CASE, SHIELD (MAIN), R
29	♣;4-342-118-00	LID, SHIELD CASE, R
30	♣;4-348-551-00	PLATE, SHIELD
31	4-812-134-11	RIVET NYLON, 3.5
32	♣;4-835-639-00	PLATE, GROUND
33	4-836-836-00	SPRING, COMPRESSION
34	4-857-425-00	BUSHING, O3P INSULATING
35	4-866-342-00	JOINT (B), KNOB
36	♣;4-880-249-11	RETAINER, TRANSFORMER
37	4-884-505-00	RETAINER
38	4-884-506-00	ROLLER
39	4-884-513-00	SPRING (A)
40	4-884-514-00	WASHER
41	4-884-515-00	SPRING (RACK), COMPRESSION
42	♣;4-884-523-00	BRACKET (B), CATCHER, RAY
43	♣;4-884-546-00	PLATE (B), STOPPER, ROLLER

GENERAL SECTION

No.	Part No.	Description
44	♣;4-884-547-00	PLATE (C), STOPPER, ROLLER
45	4-884-626-00	SPRING
46	♣;4-884-637-00	SHEET (C), INSULATING
47	4-885-775-11	CAP, MOTOR
48	4-885-801-11	SCREW (CLAW), S TIGHT, M 4X6
49	♣;4-885-818-00	SPACER
50	♣;4-885-823-00	SHEET, EDGE (A)
51	3-703-043-21	(Canadian)...LABEL, CAUTION, MAIN
51	4-885-838-00	(AEP,UK).....LABEL, CLASS 1
52	4-885-839-00	(AEP,UK).....LABEL, APERTURE
53	4-884-503-01	(US).....LABEL, CAUTION, LASER
53	♣;4-885-833-01	(Canadian)...LABEL (CAS), CAUTION, LASER
53	4-885-843-02	(AEP,UK).....LABEL, CAUTION, LASER
54	
55	4-886-552-00	SHEET, INSULATING, TRANSFORMER
56	4-887-102-01	(AEP,UK,Canadian)...PLATE, JACK
56	4-887-102-11	(US).....PLATE, JACK
57	4-887-105-00	CAP, CENTERING
58	4-887-106-00	SPRING, COMPRESSION
59	4-887-107-00	BEARING, L
60	4-887-109-00	RETAINER (RIGHT LOWER), SHAFT
61	4-887-110-00	RETAINER (LEFT LOWER), SHAFT
62	4-887-114-00	PULLEY, DISK
63	♣;4-887-115-00	SHAFT, SLIDE
64	4-887-116-00	RETAINER (RIGHT UPPER), SHAFT
65	4-887-117-00	RETAINER (LEFT UPPER), SHAFT
66	4-887-119-00	SPRING, COMPRESSION
67	4-887-120-00	SPRING, COMPRESSION (T.T.)
68	4-887-121-00	RETAINER, ADJUSTMENT PLATE, L
69	4-887-125-00	PLATE, FROSTED
70	♣;4-887-128-00	BRACKET, PC BOARD
71	4-887-131-00	KNOB, SLIDE SWITCH
72	♣;4-887-132-00	BRACKET (RIGHT), TRANSFORMER
73	♣;4-887-133-00	BRACKET (LEFT), TRANSFORMER
74	4-887-134-00	ESCUTCHEON, TOP PLATE
75	♣;4-887-135-00	RETAINER, BUTTON SHAFT
76	♣;4-887-141-00	COVER, RAY CATCHER LAMP,REMOTE
77	4-887-142-00	FILTER
78	♣;4-887-143-00	BRACKET, CHASSIS, TEN KEY
79	♣;4-887-144-00	BRACKET, SENSOR, REMOTE CONTROL
80	♣;4-887-145-00	BRACKET, TIMER SWITCH
81	♣;4-887-146-00	SHAFT, BUTTON
82	4-887-149-00	COVER, LAMP
83	♣;4-887-151-00	PLATE, GROUND
84	♣;4-887-152-00	BRACKET, H JACK
85	♣;4-887-153-00	HOLDER, PC BOARD

NOTE:

- Items with no part number and no description are not stocked because they are seldom required for routine service.
- Items marked "♣" are not stocked since they are seldom required for routine service. Some delay should be anticipated when ordering these items.
- Due to standardization, parts with part numbers (A-ΔΔΔ-ΔΔΔ-XX or A-ΔΔΔΔ-ΔΔΔ-X) may be different from those used in the set.

CAPACITORS:

- All capacitors are in μF . Common capacitors are omitted. Refer to the following lists for their part numbers.
MF: μF , PF: μPF .

RESISTORS

- All resistors are in ohms. Common 1/4W, 1/8W and 1/16W carbon resistors are omitted. Refer to the following lists for their part numbers.

- F : nonflammable

COILS

- MMH : mH, UH : μH

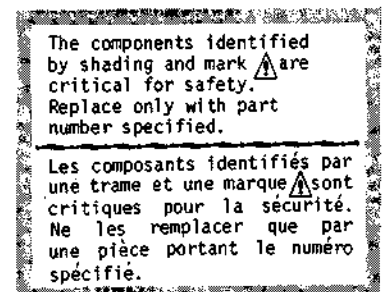

SEMICONDUCTORS

- In each case, U : μ , for example:
UA....: μA ..., UPA....: μPA ..., UPC....: μPC
UPD....: μPD ...

CDP-701ES

GENERAL SECTION

No.	Part No.	Description
86	4-887-154-00	BUTTON, SQUARE, 5X6
87	4-887-155-00	BUTTON, SQUARE, 5X10
88	4-887-158-00	BRACKET, POWER SWITCH
89	4-887-159-00	SHAFT, PLAY BUTTON, RMS
90	4-887-161-00	COVER, LEAD
91	4-887-175-00	RUBBER, STOPPER
92	4-887-179-00	PLATE, FULCRUM, TABLE LEVER
93	4-887-185-00	PLATE, SWITCH, LOADING
94	4-887-186-00	SCREW, SLIDE PLATE, TABLE
95	4-887-187-00	SCREW, FITTING, RACK
96	4-887-188-00	SHAFT (B), FULCRUM, LEVER
97	4-887-189-00	PLATE, LEAD
98	4-887-192-00	PLATE, FULCRUM, EJECT BUTTON
99	4-887-193-00	SHAFT, FULCRUM, EJECT
100	4-887-194-00	GEAR (B), LOADING
101	4-887-195-00	COVER, CHUCKING
102	4-887-196-00	STOPPER
103	4-887-201-00	GEAR (B), CHUCKING
104	4-887-203-00	PLATE, LOCK, EJECT SWITCH
105	4-887-208-00	GEAR (C), CHUCKING
106	4-887-209-02	GEAR (C), LOADING
107	4-887-210-00	GUIDE (FRONT), TABLE
108	4-887-211-00	SHAFT, STABILIZER
109	4-887-212-00	PLATE (B), FULCRUM
110	4-887-215-00	REINFORCEMENT, STOPPER
111	4-887-217-00	COVER, LEAD
112	4-887-218-00	PLATE, CONTROL, LOADING WIRE
113	4-887-219-00	PLATE, FIXED, WIRE
114	4-887-221-00	STABILIZER, CENTERING
115	4-887-222-00	WASHER, BEARING
116	4-887-224-00	RACK, LOADING
117	4-887-225-00	SPRING, TENSION (PLATE)
118	4-887-226-00	SPRING, TENSION (HOLDER B)
119	4-887-227-00	SPRING, COMPRESSION (FULCRUM)
120	4-887-228-00	SPRING, TENSION (CHANGE)
121	4-887-229-00	SPRING, TENSION (SLIDE)
122	4-887-230-00	SPRING, COMPRESSION (CHUCKING)
123	4-887-231-00	SPRING, TENSION (LEVER)
124	4-887-232-00	SPRING
125	
126	4-887-234-00	SPRING, TENSION (STOPPER)
127	4-887-235-00	ORNAMENT, LOADING PANEL
128	4-887-236-00	GUIDE, LOADING WIRE
129	4-887-237-00	BRACKET, LOADING SWITCH
130	4-887-240-00	CHASSIS, TRANSFORMER

GENERAL SECTION

No.	Part No.	Description
131	4-887-241-00	CASE, PROTECTION, LOADING GEAR
132	4-887-243-00	SHAFT, CHUCKING HOLDER
133	4-887-244-00	LEVER, TABLE
134	4-887-245-00	PLATE (LEFT), SLIDE, TABLE
135	4-887-246-00	PLATE (RIGHT), SLIDE, TABLE
136	4-887-247-00	RAIL (LEFT), FIXED SIDE
137	4-887-248-00	RAIL (RIGHT), FIXED SIDE
138	4-887-253-00	BRACKET, CHUCKING HOLDER
139	4-887-254-00	PANEL, LOADING
140	4-887-255-00	RAIL (RIGHT), MOVABLE
141	4-887-256-00	RAIL (LEFT), MOVABLE
142	4-887-259-00	ORNAMENT, PLATE, FROSTED
143	4-887-260-00	HEAT SINK (B)
144	4-887-261-00	BRACKET, ORNAMENT, PANEL
145	4-887-262-00	PLATE (LEFT), SIDE
146	4-887-263-00	PLATE (RIGHT), SIDE
147	4-887-264-00	PANEL, CONTROL BUTTON
148	4-887-265-00	BUTTON (B), REPEAT
149	4-887-266-00	LEVER, POWER SWITCH
150	4-887-267-00	BRACKET (LEFT), TOP PLATE
151	4-887-268-00	BRACKET (RIGHT), TOP PLATE
152	4-887-269-00	BRACKET, CONTROL PC BOARD
153	4-887-271-00	BUTTON, CANCEL
154	4-887-272-00	BUTTON (A), REPEAT
155	4-887-273-00	BUTTON, MS.
156	4-887-274-00	HOLDER, BUTTON, TEN KEY
157	4-887-275-00	HEAT SINK (A)
158	4-887-280-00	ANGLE (LEFT)
159	4-887-281-00	ANGLE (RIGHT)
160	4-887-282-00	CHASSIS
161	4-887-283-00	PLATE, TOP
162	4-887-284-00	CASE, SHIELD
163	4-887-285-00	HOLDER, CONTROL BUTTON
164	4-887-286-00	ANGLE (C)
165	4-887-287-00	BASE, L
166	4-887-288-00	PANEL, SUB
167	4-887-289-00	PLATE, BOTTOM
168	
169	4-887-293-00	ABSORBENT(A), VIBRATION CONTROL
170	4-887-294-00	ABSORBENT(B), VIBRATION CONTROL
171	4-887-295-00	STOPPER, LOADING
172	4-887-296-00	GEAR (A), CHUCKING
173	4-887-298-00	SHEET, PS
174	4-887-299-00	RETAINER, STOPPER, LOADING
175	4-887-701-00	COVER, LOADING

NOTE:

- Items with no part number and no description are not stocked because they are seldom required for routine service.
- Items marked " * " are not stocked since they are seldom required for routine service. Some delay should be anticipated when ordering these items.
- Due to standardization, parts with part numbers (Δ-ΔΔΔ-ΔΔΔ-XX or Δ-ΔΔΔΔ-ΔΔΔ-X) may be different from those used in the set.

CAPACITORS:

- All capacitors are in μF. Common capacitors are omitted. Refer to the following lists for their part numbers. MF:μF, PF:μμF.

RESISTORS

- All resistors are in ohms. Common 1/4W, 1/8W and 1/16W carbon resistors are omitted. Refer to the following lists for their part numbers.

- F : nonflammable

COILS

- MH : mH, UH : μH

The components identified by shading and mark  are critical for safety. Replace only with part number specified.

Les composants identifiés par une trame et une marque  sont critiques pour la sécurité. Ne les remplacer que par une pièce portant le numéro spécifié.

SEMICONDUCTORS

In each case, U : μ, for example:
 UA...: μA..., UPA...: μPA..., UPC...: μPC,
 UPD...: μPD...

GENERAL SECTION

No.	Part No.	Description
176	4-887-702-00	RACK (A)
177	4-887-703-00	RACK (B)
178	4-887-704-00	GEAR (A)
179	4-887-705-00	GEAR (B)
180	4-887-706-00	GEAR (C)
181	4-887-707-00	RETAINER, TRANSFORMER
182	4-887-708-00	HEAT SINK, TRANSFORMER
183	4-887-709-00	HEAT SINK (UPPER), DIP
184	4-887-710-00	HEAT SINK (LOWER), DIP
185	4-887-711-00	SCREW, TERMINAL, CLAW, +BVTP
186	4-887-712-00	GUIDE (LEFT), TABLE
187	4-887-713-00	GUIDE (RIGHT), TABLE
188	4-887-714-00	SHAFT, TABLE GUIDE
189	4-887-715-01	SPRING (RIGHT)
190	4-887-715-11	SPRING (LEFT)
191	
192	
193	♣;4-887-720-00	DAMPER (E), OSCILATION
194	♣;4-887-721-00	RETAINER, F PC BOARD
195	♣;4-887-722-00	SHEET (BOTTOM), PS
196	♣;4-887-723-00	REINFORCEMENT (A), PC BOARD
197	♣;4-887-724-00	DAMPER (F)
198	♣;4-887-725-00	DAMPER (G)
199	4-887-726-00	RUBBER, DAMPER, HEAT SINK
200	4-887-732-00	CUSHION, MOTOR
201	4-887-733-00	CUSHION (A)
202	4-887-734-00	CUSHION (B)
203	4-887-735-00	CUSHION (C)
204	4-887-736-00	CUSHION (D)
205	4-887-737-00	CAP, RUBBER
206	4-887-744-00	{AEP}....LABEL, MODEL NUMBER {AEP1}
206	4-887-745-00	{UK}.....LABEL, MODEL NUMBER {UK}
206	4-887-746-00	{US,Canadian}...LABEL, MODEL NUMBER {U,CND}
207	7-621-255-20	SCREW +P 2X4
208	7-621-259-25	SCREW +P 2.6X4
209	7-621-260-00	SCREW +P 2.6X16
210	7-621-283-10	SCREW +P 2X10
211	7-621-284-00	SCREW +P 2.6X4
212	7-621-284-10	SCREW +P 2.6X5
213	7-621-284-20	SCREW +P 2.6X6
214	7-621-284-30	SCREW +P 2.6X8
215	7-621-284-40	SCREW +P 2.6X10
216	7-621-284-40	SCREW +P 2.6X10
217	7-621-559-20	SCREW +K 2.6X4
218	7-621-734-09	SET-SCT, HEX. 2.6X3

GENERAL SECTION

No.	Part No.	Description
219	7-621-737-08	SET-SCT, HEX. 2.6X3, FLAT POINT
220	7-621-772-30	SCREW +B 2X6
221	7-621-775-00	SCREW +B 2.6X3
222	7-621-996-24	BOLT 2.6X4, HEXAGON SOCKET
223	7-622-207-05	N 2.6, TYPE 2
224	7-624-102-04	STOP RING 1.5, TYPE -E
225	7-624-104-04	STOP RING 2.0, TYPE -E
226	7-624-105-04	STOP RING 2.3, TYPE -E
227	7-624-106-04	STOP RING 3.0, TYPE -E
228	7-624-190-81	STOP RING 2, TYPE-CS
229	7-671-156-01	BALL, STENLESS
230	7-682-145-09	SCREW +P 3X4
231	7-682-146-01	SCREW +P 3X5
232	7-682-146-09	SCREW +P 3X5
233	7-682-147-01	SCREW +P 3X6
234	7-682-148-09	SCREW +P 3X8
235	7-682-160-09	SCREW +P 4X6
236	7-682-546-09	SCREW +B 3X4
237	7-683-408-04	BOLT, HEXAGON 3X16
238	7-683-402-04	BOLT, HEXAGON SOCKET 3X5
239	7-683-415-05	BOLT, HEXAGON SOCKET 2.6X12
240	7-685-103-11	SCREW +P 2X5 TYPE2 NON-SLIT
241	7-685-104-19	SCREW +P 2X6 TYPE2 NON-SLIT
242	7-685-133-19	SCREW +P 2.6X6 TYPE2 NON-SLIT
243	7-685-146-19	SCREW +P 3X8 TYPE2 NON-SLIT
244	7-685-147-19	SCREW +P 3X10 TYPE2 NON-SLIT
245	7-685-861-01	SCREW +BVTT 2.6X5 (S)
246	7-685-861-09	SCREW +BVTT 2.6X5 (S)
247	7-685-862-01	SCREW +BVTT 2.6X6 (S)
248	7-685-864-09	SCREW +BVTT 2.6X10 (S)
249	7-685-870-09	SCREW +BVTT 3X5 (S)
250	7-685-871-09	SCREW +BVTT 3X6 (S)
251	7-685-873-09	SCREW +BVTT 3X10 (S)
252	7-688-001-11	W 2, MIDDLE
253	7-688-001-12	W 2, MIDDLE
254	7-688-002-12	W 2.6, MIDDLE
255	7-688-003-11	W 3, MIDDLE
256	9-911-815-01	CUSHION, FF BUTTON
257	9-911-815-02	CUSHION
258	9-911-838-XX	CUSHION
259	9-911-840-XX	CUSHION, LID
260	9-911-842-XX	CUSHION (F)
261	9-911-844-XX	SPONGE, CORD
262	9-911-863-XX	INSULATOR, PC BOARD
263	♣;X-4884-502-0	HOLDER ASSY, MOTOR

NOTE:

- Items with no part number and no description are not stocked because they are seldom required for routine service.
- Items marked "♣" are not stocked since they are seldom required for routine service. Some delay should be anticipated when ordering these items.
- Due to standardization, parts with part numbers (Δ-ΔΔΔ-ΔΔΔ-XX or Δ-ΔΔΔΔ-ΔΔΔ-X) may be different from those used in the set.

CAPACITORS:

- All capacitors are in μF. Common capacitors are omitted. Refer to the following lists for their part numbers.
MF:μF, PF:μμF.

RESISTORS

- All resistors are in ohms. Common 1/4W, 1/8W and 1/16W carbon resistors are omitted. Refer to the following lists for their part numbers.

- F : nonflammable

COILS

- MMH : mH, UH : μH

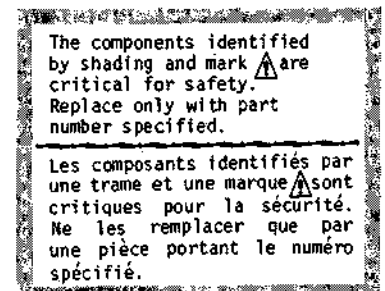

SEMICONDUCTORS

- In each case, U : μ, for example:
 UA...: μA..., UPA...: μPA..., UPC...: μPC
 UPD...: μPD...

CDP-701ES

GENERAL SECTION

No.	Part No.	Description
264	X-4887-101-0	KNOB ASSY, ATT
265	♣;X-4887-103-0	HOLDER ASSY, L
266	X-4887-104-0	KNOB ASSY, POWER
267	♣;X-4887-105-0	HOLDER ASSY, RACK
268	X-4887-106-0	BEARING ASSY, SLIDE
269	♣;X-4887-107-0	HOLDER ASSY, SWITCH
270	♣;X-4887-108-0	PLATE ASSY, ADJUSTMENT, L
271	X-4887-109-0	BUTTON ASSY, FWD
272	X-4887-110-0	STABILIZER ASSY, CHUCKING
273	♣;X-4887-113-0	PLATE (RIGHT) ASSY, FULCRUM
274	X-4887-114-0	CHASSIS ASSY, GEAR, LOADING
275	♣;X-4887-115-0	PLATE (RIGHT) ASSY, LIFT, TABLE
276	♣;X-4887-116-0	PLATE (LEFT) ASSY, LIFT, TABLE
277	♣;X-4887-117-0	PLATE ASSY, FULCRUM, LEVER
278	♣;X-4887-118-0	LEVER ASSY, CHUCKING
279	X-4887-119-0	LEVER ASSY, CHANGE, LIFTER
280	♣;X-4887-120-0	LEVER ASSY, ASSIST, HOLDER
281	♣;X-4887-121-0	PLATE (LEFT) ASSY, FULCRUM
282	X-4887-122-0	BUTTON ASSY, PAUSE
283	X-4887-123-0	BUTTON ASSY, RESET
284	X-4887-124-0	BUTTON (A) ASSY, FF
285	X-4887-125-0	BUTTON (B) ASSY, FF
286	X-4887-126-0	BUTTON (C) ASSY, FF
287	X-4887-127-0	BUTTON (D) ASSY, FF
288	X-4887-128-0	BUTTON (A) ASSY, N
289	X-4887-129-0	BUTTON (B) ASSY, N
290	X-4887-130-0	PANEL ASSY, FRONT
291	X-4887-131-0	BUTTON ASSY, RMS PLAY
292	X-4887-132-0	ESCUTCHEON ASSY, POWER SWITCH
293	♣;X-4887-133-0	REINFORCEMENT ASSY
294	♣;X-4887-134-0	HOLDER (RIGHT) ASSY, CHUCKING
295	♣;X-4887-135-0	HOLDER (LEFT) ASSY, CHUCKING
296	♣;X-4887-136-0	CHASSIS ASSY, DRIVING, CHUCKING
297	♣;X-4887-137-0	REINFORCEMENT ASSY, LOADING
298	♣;X-4887-138-0	PLATE ASSY, CHUCKING
299	X-4887-139-0	TABLE ASSY, DISK
300	X-4887-140-1	BUTTON ASSY, EJECT
301	9-911-839-XX	(AEP,UK)....PROTECTOR (C)
302	7-685-646-19	SCREW, +BVTP 3X8 TYPE2
303	7-721-773-95	SCREW, +B 2.6X6
304	4-023-575-00	CUSHION
305	♣;3-703-044-26	(US,Canadian)...LABEL, CAUTION
306	♣;3-667-648-00	(Canadian)...LABEL, CAUTION, LASER
307	♣;3-703-680-00	(US)....LABEL, CAUTION, SUB, NEW UL
308	9-911-839-XX	CUSHION

GENERAL SECTION

No.	Part No.	Description
309	
310	♣;4-884-680-00	(Canadian)...LABEL
311	♣;4-887-741-00	(Canadian)...LABEL (M), LASER MAKER
312	♣;4-887-751-00	SHEET (MT), INSULATING
313	4-887-752-00	FOOT
314	♣;4-887-753-00	(US)...COVER, INSULATING, FILTER
315	♣;4-887-754-00	SHEET (A), INSULATING, MT
316	4-887-755-00	(AEP,UK)...SHEET (B), INSULATING (MT)
317	7-682-948-09	(US)....SCREW +PSW 3X8
318	7-684-220-03	(US)....NUT 3, HEXAGON CAP

ACCESSORY & PACKING MATERIAL

No.	Part No.	Description
351	1-556-884-21	(AEP,UK).....CORD, CONNECTION (RK-C77)
351	1-556-942-00	(US,Canadian)...CORD, CONNECTION
352	1-804-085-00	(UK)....PLUG, AC
353	3-701-619-00	BAG, POLYETHYLENE, STANDARD
354	3-701-630-00	BAG, POLYETHYLENE
355	3-703-390-01	(US)....INSTRUCTION
356	3-773-325-11	(AEP,UK).....MANUAL, INSTRUCTION
356	3-773-325-21	(US,Canadian)...MANUAL, INSTRUCTION
356	3-773-325-31	(Canadian).....MANUAL, INSTRUCTION
356	3-773-325-41	(AEP).....MANUAL, INSTRUCTION
357	3-795-629-11	(AEP)....INSTRUCTION
358	4-858-078-00	SHEET, PROTECTION (FOR CDP-701ES SET)
359	4-884-633-00	COVER, CONNECTOR
360	4-885-820-00	BAG, PROTECTION (FOR RM-101 SET)
361	4-887-727-00	CUSHION (RIGHT), UPPER
362	4-887-728-00	CUSHION (LEFT), UPPER
363	4-887-729-00	CUSHION (RIGHT), LOWER
364	4-887-730-00	CUSHION (RIGHT), LOWER
365	4-887-749-00	INDIVIDUAL CARTON
366	4-887-750-00	SPACER
367	A-4600-276-A	COMMANDER COMPLETE ASSY (RM-101)
368	X-4884-523-0	CLEANER ASSY, DISC

NOTE:

- Items with no part number and no description are not stocked because they are seldom required for routine service.
- Items marked "♣" are not stocked since they are seldom required for routine service. Some delay should be anticipated when ordering these items.
- Due to standardization, parts with part numbers (Δ-ΔΔΔ-ΔΔΔ-XX or Δ-ΔΔΔΔ-ΔΔΔ-X) may be different from those used in the set.

CAPACITORS:

- All capacitors are in μF. Common capacitors are omitted. Refer to the following lists for their part numbers.
MF:μF, PF:μμF.

RESISTORS

- All resistors are in ohms. Common 1/4W, 1/8W and 1/16W carbon resistors are omitted. Refer to the following lists for their part numbers.

- F : nonflammable

COILS

- MMH : mH, UH : μH

The components identified by shading and mark  are critical for safety. Replace only with part number specified.

Les composants identifiés par une trame et une marque  sont critiques pour la sécurité. Ne les remplacer que par une pièce portant le numéro spécifié.

SEMICONDUCTORS

In each case, U : μ, for example:
UA....: μA...., UPA....: μPA...., UPC....: μPC,
UPD....: μPD....

ELECTRICAL PARTS

Ref.No.	Part No.	Description
501	1-553-131-00	HOLDER, FUSE
502	♣;1-535-117-00	TERMINAL, 4P
503	♣;1-535-121-00	TERMINAL, 8P
504	♣;1-535-149-11	WIRE (30.0MM)
505	♣;1-535-416-00	TERMINAL
506	△;1-555-975-00	(AEP).....CORD, POWER
506	△;1-556-035-00	(UK).....CORD, POWER
506	△;1-555-701-00	(US,Canadian)....CORD, POWER
507	♣;1-560-242-11	BUS BAR 3P
508	♣;1-560-242-21	BUS BAR 4P
509	1-564-186-21	BAR, BUS
510	1-564-295-00	BAR, BUS
511	♣;1-603-976-00	PC BOARD, M
512	♣;1-609-582-00	PC BOARD, SERVO
513	♣;1-609-583-00	PC BOARD, DISPLAY
514	♣;1-609-584-00	PC BOARD, DISPLAY IC
515	♣;1-609-585-00	PC BOARD, EJECT SW
516	♣;1-609-586-00	PC BOARD, FLEXIBLE
517	♣;1-609-587-00	PC BOARD, CONTROL SW
518	♣;1-609-588-00	PC BOARD, 10 KEY SW
519	♣;1-609-589-00	PC BOARD, POWER SUPPLY
520	♣;1-610-747-00	PC BOARD, POWER SW
521	♣;1-609-593-00	PC BOARD, LOADING
522	♣;1-609-594-00	PC BOARD, PHOTO TRANSISTOR
523	♣;1-609-595-00	PC BOARD, LED
524	♣;1-609-596-00	PC BOARD, LIMIT IN SW
525	♣;1-609-597-00	PC BOARD, HEADPHONE AMP
526	♣;1-609-598-00	PC BOARD, HEADPHONE JACK
527	♣;1-609-599-00	PC BOARD, LINE OUT
528	♣;1-609-601-00	PC BOARD, I/O
529	♣;1-610-161-00	PC BOARD, MD TRANSLATION
530	♣;A-4619-195-A	MOUNTED PCB, SERVO
531	♣;A-4651-003-A	MOUNTED PCB, AUDIO
532	X-4887-141-2	OPTICAL PICK-UP BLOCK (KSC-100A)
1B1	1-232-004-00	COMPOSITION CIRCUIT BLOCK
BZ701	1-629-016-00	BUZZER, PIEZOELECTRIC
C1	1-123-617-00	ELECT 10MF 20% 16V
C2	1-123-617-00	ELECT 10MF 20% 16V
C3	1-123-617-00	ELECT 10MF 20% 16V
C4	1-161-019-00	CERAMIC 0.033MF 10% 25V
C5	1-108-567-00	MYLAR 0.0033MF 5% 50V
C101	1-162-113-00	CERAMIC 0.01MF 30% 16V
C102	1-123-380-00	ELECT 1MF 20% 50V
C103	1-131-368-00	TANTALUM 3.3MF 20% 16V
C104	1-131-368-00	TANTALUM 3.3MF 20% 16V

ELECTRICAL PARTS

Ref.No.	Part No.	Description			
C105	1-131-368-00	TANTALUM	3.3MF	20%	16V
C106	1-131-368-00	TANTALUM	3.3MF	20%	16V
C111	1-162-024-00	CERAMIC	30PF	5%	50V
C112	1-162-024-00	CERAMIC	30PF	5%	50V
C113	1-162-024-00	CERAMIC	30PF	5%	50V
C114	1-162-024-00	CERAMIC	30PF	5%	50V
C117	1-162-025-00	CERAMIC	33PF	5%	50V
C118	1-131-371-00	TANTALUM	10MF	20%	16V
C119	1-131-371-00	TANTALUM	10MF	20%	16V
C120	1-162-010-00	CERAMIC	5.6PF	10%	50V
C121	1-162-017-00	CERAMIC	15PF	5%	50V
C122	1-102-735-00	CERAMIC	2.2PF	10%	50V
C123	1-162-025-00	CERAMIC	33PF	5%	50V
C124	1-102-735-00	CERAMIC	2.2PF	10%	50V
C125	1-102-735-00	CERAMIC	2.2PF	10%	50V
C126	1-162-113-00	CERAMIC	0.01MF	30%	16V
C127	1-162-113-00	CERAMIC	0.01MF	30%	16V
C128	1-130-620-00	FILM	0.01MF	5%	50V
C129	1-162-110-00	CERAMIC	0.001MF	10%	50V
C130	1-130-620-00	FILM	0.01MF	5%	50V
C131	1-162-108-00	CERAMIC	680PF	10%	50V
C132	1-130-620-00	FILM	0.01MF	5%	50V
C133	1-162-108-00	CERAMIC	680PF	10%	50V
C134	1-130-620-00	FILM	0.01MF	5%	50V
C135	1-131-368-00	TANTALUM	3.3MF	20%	16V
C136	1-131-368-00	TANTALUM	3.3MF	20%	16V
C137	1-162-113-00	CERAMIC	0.01MF	30%	16V
C138	1-123-492-00	ELECT	33MF	20%	25V
C151	1-162-032-00	CERAMIC	62PF	5%	50V
C152	1-162-032-00	CERAMIC	62PF	5%	50V
C153	1-162-056-00	CERAMIC	33PF	5%	50V
C154	1-162-056-00	CERAMIC	33PF	5%	50V
C155	1-130-620-00	FILM	0.01MF	5%	50V
C156	1-162-007-00	CERAMIC	3.3PF	10%	50V
C157	1-162-007-00	CERAMIC	3.3PF	10%	50V
C158	1-162-033-00	CERAMIC	68PF	5%	50V
C159	1-162-033-00	CERAMIC	68PF	5%	50V
C160	1-162-037-00	CERAMIC	100PF	5%	50V
C161	1-162-037-00	CERAMIC	100PF	5%	50V
C162	1-108-569-00	MYLAR	0.0039MF	5%	50V
C163	1-130-620-00	FILM	0.01MF	5%	50V
C164	1-108-567-00	MYLAR	0.0033MF	5%	50V
C165	1-162-037-00	CERAMIC	100PF	5%	50V
C166	1-130-620-00	FILM	0.01MF	5%	50V
C167	1-102-735-00	CERAMIC	120PF	5%	50V

NOTE:

- Items with no part number and no description are not stocked because they are seldom required for routine service.
- Items marked "♣" are not stocked since they are seldom required for routine service. Some delay should be anticipated when ordering these items.
- Due to standardization, parts with part numbers (Δ-ΔΔΔ-ΔΔΔ-XX or Δ-ΔΔΔΔ-ΔΔΔ-X) may be different from those used in the set.

CAPACITORS:

- All capacitors are in μF. Common capacitors are omitted. Refer to the following lists for their part numbers. MF:μF, PF:μμF.

RESISTORS

- All resistors are in ohms. Common 1/4W, 1/8W and 1/16W carbon resistors are omitted. Refer to the following lists for their part numbers.

- F : nonflammable

COILS

- MMH : mH, UH : μH

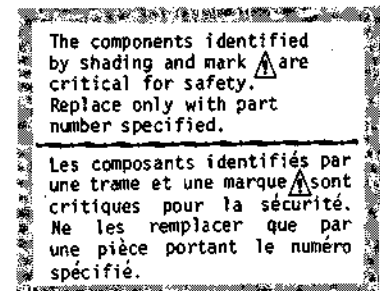

SEMICONDUCTORS

- In each case, U : μ, for example:
 UA... : μA... , UPA... : μPA... , UPC... : μPC,
 UPD... : μPD...

CDP-701ES

ELECTRICAL PARTS

Ref.No.	Part No.	Description			
C168	1-108-571-00	MYLAR	0.0047MF	5%	50V
C169	1-162-113-00	CERAMIC	0.01MF	30%	16V
C170	1-162-113-00	CERAMIC	0.01MF	30%	16V
C171	1-162-113-00	CERAMIC	0.01MF	30%	16V
C172	1-130-620-00	FILM	0.01MF	5%	50V
C173	1-123-380-00	ELECT	1MF	20%	50V
C174	1-130-620-00	FILM	0.01MF	5%	50V
C175	1-123-691-00	ELECT	33MF	20%	25V
C176	1-123-691-00	ELECT	33MF	20%	25V
C201	1-102-852-00	CERAMIC	47PF	5%	50V
C202	1-102-852-00	CERAMIC	47PF	5%	50V
C203	1-130-620-00	FILM	0.01MF	5%	50V
C204	1-108-555-00	MYLAR	0.001MF	5%	50V
C205	1-162-111-00	CERAMIC	0.0022MF	30%	25V
C206	1-162-111-00	CERAMIC	0.0022MF	30%	25V
C207	1-123-356-00	ELECT	10MF	20%	50V
C208	1-102-645-00	CERAMIC	33PF	5%	50V
C209	1-102-645-00	CERAMIC	33PF	5%	50V
C210	1-162-102-00	CERAMIC	220PF	10%	50V
C211	1-102-647-00	CERAMIC	39PF	5%	50V
C212	1-102-647-00	CERAMIC	39PF	5%	50V
C214	1-131-368-00	TANTALUM	3.3MF	20%	16V
C215	1-123-492-00	ELECT	33MF	20%	25V
C216	1-123-492-00	ELECT	33MF	20%	25V
C217	1-123-492-00	ELECT	33MF	20%	25V
C218	1-123-492-00	ELECT	33MF	20%	25V
C219	1-131-380-00	TANTALUM	33MF	20%	10V
C220	1-131-380-00	TANTALUM	33MF	20%	10V
C223	1-102-516-00	CERAMIC	27PF	5%	50V
C224	1-102-074-00	CERAMIC	0.001MF	10%	50V
C225	1-131-380-00	TANTALUM	33MF	20%	10V
C226	1-131-380-00	TANTALUM	33MF	20%	10V
C228	1-131-522-00	TANTALUM	10MF	20%	25V
C229	1-131-522-00	TANTALUM	10MF	20%	25V
C301	1-131-526-00	TANTALUM	33MF	20%	10V
C302	1-131-526-00	TANTALUM	33MF	20%	10V
C303	1-131-450-00	TANTALUM	1MF	20%	50V
C304	1-104-239-00	POLYSTYRENE	0.0015MF	5%	125V
C305	1-131-526-00	TANTALUM	33MF	20%	10V
C306	1-131-526-00	TANTALUM	33MF	20%	10V
C307	1-107-309-00	MICA	100PF	5%	500V
C309	1-131-526-00	TANTALUM	33MF	20%	10V
C310	1-131-526-00	TANTALUM	33MF	20%	10V
C311	1-123-685-00	ELECT	470MF	20%	16V
C312	1-131-450-00	TANTALUM	1MF	20%	50V

ELECTRICAL PARTS

Ref.No.	Part No.	Description			
C331	1-108-555-00	MYLAR	0.001MF	5%	50V
C351	1-131-450-00	TANTALUM	1MF	20%	50V
C352	1-131-450-00	TANTALUM	1MF	20%	50V
C353	1-131-522-00	TANTALUM	10MF	20%	25V
C354	1-131-522-00	TANTALUM	10MF	20%	25V
C355	1-107-326-00	MICA	0.0047MF	2%	100V
C356	1-107-310-00	MICA	220PF	5%	500V
C357	1-107-327-00	MICA	7PF		500V
C359	1-107-310-00	MICA	220PF	5%	500V
C360	1-107-310-00	MICA	220PF	5%	500V
C371	1-123-683-00	ELECT	220MF	20%	16V
C391	1-101-002-00	CERAMIC	0.0022MF		50V
C401	1-131-526-00	TANTALUM	33MF	20%	10V
C402	1-131-526-00	TANTALUM	33MF	20%	10V
C403	1-131-450-00	TANTALUM	1MF	20%	50V
C404	1-104-239-00	POLYSTYRENE	0.0015MF	5%	125V
C405	1-131-526-00	TANTALUM	33MF	20%	10V
C406	1-131-526-00	TANTALUM	33MF	20%	10V
C407	1-107-309-00	MICA	100PF	5%	500V
C409	1-131-526-00	TANTALUM	33MF	20%	10V
C410	1-131-526-00	TANTALUM	33MF	20%	10V
C411	1-123-685-00	ELECT	470MF	20%	16V
C412	1-131-450-00	TANTALUM	1MF	20%	50V
C451	1-131-450-00	TANTALUM	1MF	20%	50V
C452	1-131-450-00	TANTALUM	1MF	20%	50V
C453	1-131-522-00	TANTALUM	10MF	20%	25V
C454	1-131-522-00	TANTALUM	10MF	20%	25V
C456	1-107-326-00	MICA	0.0047MF	2%	100V
C458	1-107-310-00	MICA	220PF	5%	500V
C457	1-107-327-00	MICA	7PF		500V
C459	1-107-310-00	MICA	220PF	5%	500V
C460	1-107-310-00	MICA	220PF	5%	500V
C471	1-123-683-00	ELECT	220MF	20%	16V
C505	1-123-317-00	ELECT	22MF	20%	16V
C506	1-130-188-00	FILM	0.01MF	5%	100V
C507	1-130-626-00	FILM	0.033MF	5%	50V
C508	1-130-620-00	FILM	0.01MF	5%	50V
C509	1-123-380-00	ELECT	1MF	20%	50V
C510	1-130-628-00	FILM	0.047MF	5%	50V
C512	1-123-474-00	ELECT	100MF	20%	10V
C513	1-162-106-00	CERAMIC	470PF	10%	50V
C514	1-130-624-00	FILM	0.022MF	5%	50V
C515	1-130-620-00	FILM	0.01MF	5%	50V
C516	1-123-681-00	ELECT	47MF	20%	16V
C517	1-123-681-00	ELECT	47MF	20%	16V

NOTE:

- Items with no part number and no description are not stocked because they are seldom required for routine service.
- Items marked " * " are not stocked since they are seldom required for routine service. Some delay should be anticipated when ordering these items.
- Due to standardization, parts with part numbers (A-AAA-AAA-XX or A-AAA-AAA-X) may be different from those used in the set.

CAPACITORS:

- All capacitors are in μF . Common capacitors are omitted. Refer to the following lists for their part numbers. MF: μF , PF: μF .

RESISTORS

- All resistors are in ohms. Common 1/4W, 1/8W and 1/16W carbon resistors are omitted. Refer to the following lists for their part numbers.

- F : nonflammable

COILS

- MMH : mH, UH : μH

The components identified by shading and mark Δ are critical for safety. Replace only with part number specified.

Les composants identifiés par une trame et une marque Δ sont critiques pour la sécurité. Ne les remplacer que par une pièce portant le numéro spécifié.

SEMICONDUCTORS

In each case, U : μ , for example:
 UA.... : μA ..., UPA.... : μPA ..., UPC.... : μPC ,
 UPD.... : μPD ...

ELECTRICAL PARTS

Ref.No.	Part No.	Description			
C518	1-130-620-00	FILM	0.01MF	5%	50V
C519	1-123-474-00	ELECT	100MF	20%	10V
C520	1-123-493-00	ELECT	47MF	20%	16V
C521	1-123-493-00	ELECT	47MF	20%	16V
C601	1-123-305-00	ELECT	33MF	20%	10V
C602	1-124-185-00	ELECT	4.7MF	20%	50V
C603	1-124-182-00	ELECT	1MF	20%	50V
C604	1-130-628-00	FILM	0.047MF	5%	50V
C605	1-102-947-00	CERAMIC	10PF	5%	50V
C606	1-130-629-00	FILM	0.056MF	5%	50V
C607	1-130-620-00	FILM	0.01MF	5%	50V
C608	1-102-112-00	CERAMIC	330PF	10%	50V
C609	1-130-638-00	FILM	0.33MF	5%	50V
C610	1-108-565-00	MYLAR	0.0027MF	5%	50V
C611	1-108-573-00	MYLAR	0.0056MF	5%	50V
C612	1-102-074-00	CERAMIC	0.001MF	10%	50V
C613	1-130-620-00	FILM	0.01MF	5%	50V
C614	1-130-628-00	FILM	0.047MF	5%	50V
C615	1-130-626-00	FILM	0.033MF	5%	50V
C616	1-130-624-00	FILM	0.022MF	5%	50V
C617	1-123-317-00	ELECT	22MF	20%	16V
C618	1-123-328-00	ELECT	4.7MF	20%	25V
C619	1-123-380-00	ELECT	1MF	20%	50V
C620	1-130-622-00	FILM	0.015MF	5%	50V
C622	1-123-483-00	ELECT	47MF	20%	16V
C701	1-102-973-00	CERAMIC	100PF	5%	50V
C702	1-102-973-00	CERAMIC	100PF	5%	50V
C703	1-123-493-00	ELECT	47MF	20%	16V
C704	1-102-112-00	CERAMIC	330PF	10%	50V
C705	1-102-110-00	CERAMIC	220PF	10%	50V
C706	1-102-110-00	CERAMIC	220PF	10%	50V
C707	1-123-356-00	ELECT	10MF	20%	16V
C708	1-130-620-00	FILM	0.01MF	5%	50V
C709	1-123-356-00	ELECT	10MF	20%	16V
C710	1-123-356-00	ELECT	10MF	20%	16V
C711	1-123-380-00	ELECT	1MF	20%	50V
C751	1-130-632-00	FILM	0.1MF	5%	50V
C752	1-124-186-00	ELECT	10MF	20%	50V
C753	1-162-029-00	CERAMIC	47PF	5%	50V
C754	1-162-110-00	CERAMIC	0.001MF	10%	50V
C755	1-162-110-00	CERAMIC	0.001MF	10%	50V
C756	1-130-632-00	FILM	0.1MF	5%	50V
C757	1-124-183-00	ELECT	2.2MF	20%	25V
C785	1-130-640-00	FILM	0.47MF	5%	50V
C786	1-130-640-00	FILM	0.47MF	5%	50V

ELECTRICAL PARTS

Ref.No.	Part No.	Description			
C787	1-130-640-00	FILM	0.47MF	5%	50V
C791	1-108-571-00	MYLAR	0.0047MF	5%	50V
C792	1-108-571-00	MYLAR	0.0047MF	5%	50V
C793	1-101-003-00	CERAMIC	0.0047MF		50V
C801	1-123-619-00	ELECT	4.7MF	20%	50V
C802	1-123-619-00	ELECT	4.7MF	20%	50V
C803	1-101-002-00	CERAMIC	0.0022MF		50V
C804	1-101-002-00	CERAMIC	0.0022MF		50V
C901	1-124-346-00	ELECT	680MF	20%	25V
C902	1-123-696-00	ELECT	470MF	20%	25V
C903	1-123-359-00	ELECT	47MF	20%	50V
C904	1-131-522-00	TANTALUM	10MF	20%	25V
C905	1-131-563-00	TANTALUM	47MF	20%	35V
C906	1-131-450-00	TANTALUM	1MF	20%	50V
C907	1-124-417-00	ELECT	820MF	20%	16V
C908	1-124-068-00	ELECT	47MF	20%	10V
C909	1-131-450-00	TANTALUM	1MF	20%	50V
C910	1-123-311-00	ELECT	100QMF	20%	10V
C911	1-123-380-00	ELECT	1MF	20%	50V
C912	1-131-383-00	TANTALUM	10MF	10%	6.3V
C913	1-123-681-00	ELECT	47MF	20%	16V
C914	1-131-450-00	TANTALUM	1MF	20%	50V
C915	1-131-450-00	TANTALUM	1MF	20%	50V
C916	1-123-683-00	ELECT	220MF	20%	16V
C917	1-102-074-00	CERAMIC	0.001MF	10%	50V
C918	1-107-322-00	MICA	22PF	5%	500V
C919	1-131-450-00	TANTALUM	1MF	20%	50V
C951	1-124-346-00	ELECT	680MF	20%	25V
C952	1-123-696-00	ELECT	470MF	20%	25V
C953	1-123-359-00	ELECT	47MF	20%	50V
C954	1-131-522-00	TANTALUM	10MF	20%	25V
C955	1-131-563-00	TANTALUM	47MF	20%	35V
C956	1-131-450-00	TANTALUM	1MF	20%	50V
C957	1-124-346-00	ELECT	470MF	20%	16V
C958	1-124-068-00	ELECT	47MF	20%	10V
C959	1-131-450-00	TANTALUM	1MF	20%	50V
C960	1-123-311-00	ELECT	100QMF	20%	10V
C961	1-123-505-00	ELECT	220MF	20%	35V
C962	1-123-374-00	ELECT	100MF	20%	63V
C963	1-123-376-00	ELECT	330MF	20%	63V
C964	1-131-450-00	TANTALUM	1MF	20%	50V
C965	1-131-450-00	TANTALUM	1MF	20%	50V
C966	1-123-683-00	ELECT	220MF	20%	16V
C967	1-102-074-00	CERAMIC	0.001MF	10%	50V
C968	1-107-322-00	MICA	22PF	5%	500V

NOTE:

- Items with no part number and no description are not stocked because they are seldom required for routine service.
- Items marked " * " are not stocked since they are seldom required for routine service. Some delay should be anticipated when ordering these items.
- Due to standardization, parts with part numbers (A-AAA-AAA-XX or A-AAA-AAA-X) may be different from those used in the set.

CAPACITORS:

- All capacitors are in μF . Common capacitors are omitted. Refer to the following lists for their part numbers. MF: μF , PF: $\mu\mu\text{F}$.

RESISTORS

- All resistors are in ohms. Common 1/4W, 1/8W and 1/16W carbon resistors are omitted. Refer to the following lists for their part numbers.

* F : nonflammable

COILS

- MMH : mH, UH : μH

The components identified by shading and mark **A** are critical for safety. Replace only with part number specified.

Les composants identifiés par une trame et une marque **A** sont critiques pour la sécurité. Ne les remplacer que par une pièce portant le numéro spécifié.

SEMICONDUCTORS

- In each case, U : μ , for example: UA...: μA ..., UPA...: μPA ..., UPC...: μPC UPD...: μPD ...

CDP-701ES

ELECTRICAL PARTS

Ref.No.	Part No.	Description
C969	1-131-450-00	TANTALUM 1MF 20% 50V
C981	△ 1-161-734-00	(AEP,UK)...CERAMIC 2200PF 20% 400V
C982	△ 1-161-734-00	(AEP,UK)...CERAMIC 2200PF 20% 400V
C983	△ 1-161-734-00	(AEP,UK)...CERAMIC 2200PF 20% 400V
CNP3	♣;1-560-060-00	PIN, CONNECTOR 2P
CNP5	♣;1-560-060-00	PIN, CONNECTOR 2P
CNP6	♣;1-560-060-00	PIN, CONNECTOR 2P
CNP7	♣;1-560-060-00	PIN, CONNECTOR 2P
CNP8	♣;1-560-060-00	PIN, CONNECTOR 2P
CNP9	♣;1-560-060-00	PIN, CONNECTOR 2P
CNP10	♣;1-560-060-00	PIN, CONNECTOR 2P
CNP11	♣;1-560-061-00	PIN, CONNECTOR 3P
CNP12	♣;1-560-060-00	PIN, CONNECTOR 2P
CNP14	♣;1-560-062-00	PIN, CONNECTOR 4P
CNP15	♣;1-560-065-00	PIN, CONNECTOR 8P
CNP20	♣;1-560-062-00	PIN, CONNECTOR 4P
CNP21	♣;1-560-062-00	PIN, CONNECTOR 4P
CNP22	♣;1-560-064-00	PIN, CONNECTOR 6P
CNP23	♣;1-560-065-00	PIN, CONNECTOR 8P
CNP24	♣;1-560-060-00	PIN, CONNECTOR 2P
CNP25	♣;1-560-062-00	PIN, CONNECTOR 4P
CNP26	♣;1-560-065-00	PIN, CONNECTOR 8P
CNP27	♣;1-560-065-00	PIN, CONNECTOR 8P
CNP28	♣;1-560-064-00	PIN, CONNECTOR 6P
CNP29	♣;1-560-064-00	PIN, CONNECTOR 6P
CNP30	♣;1-560-339-00	PIN, CONNECTOR 9P
CNP31	♣;1-560-061-00	PIN, CONNECTOR 3P
CNP32	♣;1-560-064-00	PIN, CONNECTOR 6P
CNP33	♣;1-560-064-00	PIN, CONNECTOR 6P
CNP34	♣;1-560-063-00	PIN, CONNECTOR 5P
CNP35	♣;1-560-061-00	PIN, CONNECTOR 3P
CNP36	♣;1-560-060-00	PIN, CONNECTOR 2P
CNP37	♣;1-560-060-00	PIN, CONNECTOR 2P
CNP39	♣;1-560-338-00	PIN, CONNECTOR 7P
CNP40	♣;1-560-062-00	PIN, CONNECTOR 4P
CNP41	♣;1-560-064-00	PIN, CONNECTOR 6P
CNP50	♣;1-560-064-00	PIN, CONNECTOR 6P
CNP51	♣;1-560-065-00	PIN, CONNECTOR 8P
CNP52	♣;1-560-070-00	BASE POST 5P
CNP53	♣;1-560-062-00	PIN, CONNECTOR 4P
CNP54	♣;1-560-061-00	PIN, CONNECTOR 3P
CNP55	♣;1-560-064-00	PIN, CONNECTOR 6P
CNP56	♣;1-560-338-00	PIN, CONNECTOR 7P
CNP57	♣;1-560-061-00	PIN, CONNECTOR 3P
CNP58	♣;1-508-880-00	BASE POST, MCD CONNECTOR 6P
CNP59	♣;1-560-062-00	PIN, CONNECTOR 4P

ELECTRICAL PARTS

Ref.No.	Part No.	Description
CNP60	♣;1-560-062-00	PIN, CONNECTOR 4P
CNP70	♣;1-508-879-00	BASE POST 4P
CNP71	♣;1-560-594-00	BASE POST, MCD CONNECTOR 9P
CNP72	♣;1-560-070-00	BASE POST 5P
CNP75	♣;1-508-878-00	BASE POST 3P
CNP76	♣;1-508-878-00	BASE POST 3P
CNP90	♣;1-560-063-00	PIN, CONNECTOR 5P
CNP91	♣;1-560-064-00	PIN, CONNECTOR 6P
♣CNP801	♣;1-560-076-00	PIN, CONNECTOR
♣CNP802	♣;1-560-074-00	PIN, CONNECTOR
CP901A	1-130-456-00	(AEP)...FILM 0.022MF 20% 250V
CP901A	1-161-744-00	(UK)...CERAMIC 0.01MF 400V
CP901A	1-161-794-00	(US,Canadian)...CERAMIC 10000PF 125V
D1	8-719-110-32	DIODE PH302B
D151	8-719-911-19	DIODE 1SS119
D152	8-719-911-19	DIODE 1SS119
D153	8-719-911-19	DIODE 1SS119
D154	8-719-911-19	DIODE 1SS119
D156	8-719-911-19	DIODE 1SS119
D157	8-719-911-19	DIODE 1SS119
D158	8-719-911-19	DIODE 1SS119
D159	8-719-911-19	DIODE 1SS119
D160	8-719-911-19	DIODE 1SS119
D161	8-719-911-19	DIODE 1SS119
D201	8-719-911-19	DIODE 1SS119
D202	8-719-910-98	DIODE HZ9C2L
D203	8-719-912-28	DIODE KV1226-F
D209	8-719-100-30	DIODE RD5.1E-B2
D210	8-719-100-30	DIODE RD5.1E-B2
D211	8-719-100-30	DIODE RD5.1E-B2
D212	8-719-100-30	DIODE RD5.1E-B2
D301	8-719-100-13	DIODE RD2.7E-B2
D302	8-719-100-13	DIODE RD2.7E-B2
D303	8-719-200-13	DIODE 10YD1.3
D304	8-719-951-13	DIODE HZ5C1L
D305	8-719-200-45	DIODE 10YD4.5
D306	8-719-951-13	DIODE HZ5C1L
D307	8-719-200-47	DIODE 10YD4.5B
D308	8-719-910-65	DIODE HZ6B2L
D351	8-719-911-19	DIODE 1SS119
D401	8-719-100-13	DIODE RD2.7E-B2
D402	8-719-100-13	DIODE RD2.7E-B2
D403	8-719-200-13	DIODE 10YD1.3
D404	8-719-951-13	DIODE HZ5C1L
D405	8-719-200-45	DIODE 10YD4.5
D406	8-719-951-13	DIODE HZ5C1L

NOTE:
 • Items with no part number and no description are not stocked because they are seldom required for routine service.
 • Items marked "♣" are not stocked since they are seldom required for routine service. Some delay should be anticipated when ordering these items.
 • Due to standardization, parts with part numbers (A-ΔΔΔ-ΔΔΔ-XX or A-ΔΔΔΔ-ΔΔΔ-X) may be different from those used in the set.

CAPACITORS:
 • All capacitors are in μF. Common capacitors are omitted. Refer to the following lists for their part numbers.
 MF:μF, PF:μμF.
RESISTORS
 • All resistors are in ohms. Common 1/4W, 1/8W and 1/16W carbon resistors are omitted. Refer to the following lists for their part numbers.
 • F : nonflammable
COILS
 • MH : mH, UH : μH

The components identified by shading and mark **△** are critical for safety. Replace only with part number specified.

Les composants identifiés par une trame et une marque **△** sont critiques pour la sécurité. Ne les remplacer que par une pièce portant le numéro spécifié.

SEMICONDUCTORS
 In each case, U : μ, for example:
 UA... : μA... , UPA... : μPA... , UPC... : μPC... ,
 UPD... : μPD...

ELECTRICAL PARTS

Ref.No.	Part No.	Description
D407	8-719-200-47	DIODE 10YD4.5B
D408	8-719-910-65	DIODE HZ6B2L
D451	8-719-911-19	DIODE 1SS119
D503	8-719-911-19	DIODE 1SS119
D504	8-719-911-19	DIODE 1SS119
D505	8-719-911-19	DIODE 1SS119
D601	8-719-911-19	DIODE 1SS119
D602	8-719-100-12	DIODE RD2.7E-B1
D603	8-719-100-12	DIODE RD2.7E-B1
D604	8-719-100-12	DIODE RD2.7E-B1
D605	8-719-100-12	DIODE RD2.7E-B1
D606	8-719-911-19	DIODE 1SS119
D608	8-719-911-19	DIODE 1SS119
D611	8-719-911-19	DIODE 1SS119
D612	8-719-100-12	DIODE RD2.7E-B1
D618	8-719-911-19	DIODE 1SS119
D619	8-719-911-19	DIODE 1SS119
D620	8-719-911-19	DIODE 1SS119
D621	8-719-100-12	DIODE RD2.7E-B1
D701	8-719-911-19	DIODE 1SS119
D702	8-719-911-19	DIODE 1SS119
D703	8-719-812-31	DIODE TLR123
D704	8-719-100-13	DIODE RD5.1E-B2
D705	8-719-924-34	DIODE PR2434D
D751	8-719-100-12	DIODE RD2.7E-B1
D752	8-719-911-19	DIODE 1SS119
D753	8-719-911-19	DIODE 1SS119
D754	8-719-911-19	DIODE 1SS119
D755	8-719-911-19	DIODE 1SS119
D756	8-719-911-19	DIODE 1SS119
D757	8-719-911-19	DIODE 1SS119
D781	8-719-200-02	DIODE 10E-2
D782	8-719-200-02	DIODE 10E-2
D783	8-719-200-02	DIODE 10E-2
D801	8-719-907-81	DIODE BG5535S
D851	8-719-907-81	DIODE BG5535S
D852	8-719-907-80	DIODE AA5535S
D853	8-719-800-15	DIODE TLG211
D854	8-719-800-15	DIODE TLG211
D855	8-719-800-15	DIODE TLG211
D856	8-719-907-84	DIODE PR5535S
D901	8-719-200-25	DIODE PR106Q
D904	8-719-902-87	DIODE EQB01-08Q
D906	8-719-200-02	DIODE 10E-2
D907	8-719-200-13	DIODE 10YD1.3

ELECTRICAL PARTS

Ref.No.	Part No.	Description
D908	8-719-951-12	DIODE HZ5BLL
D911	8-719-911-19	DIODE 1SS119
D912	8-719-911-19	DIODE 1SS119
D913	8-719-911-19	DIODE 1SS119
D951	8-719-200-25	DIODE PR106Q
D954	8-719-902-87	DIODE EQB01-08Q
D956	8-719-200-02	DIODE 10E-2
D957	8-719-200-13	DIODE 10YD1.3
D958	8-719-951-12	DIODE HZ5BLL
D961	8-719-937-06	DIODE EQA01-06S
D962	8-719-200-02	DIODE 10E-2
D963	8-719-200-02	DIODE 10E-2
D964	8-719-992-81	DIODE EQA01-28R1
F901	1-532-215-00	{AEP,UK},.....FUSE, TIME-LAG 0.8A
F901	1-532-555-00	{US,Canadian}...FUSE, GLASS TUBE 1.6A
IC1	8-759-113-73	IC UPC1373H
IC101	8-759-101-37	IC UPC357C
IC102	8-759-101-37	IC UPC357C
IC103	8-759-101-37	IC UPC357C
IC104	8-759-101-37	IC UPC357C
IC105	8-759-101-37	IC UPC357C
IC106	8-759-101-37	IC UPC357C
IC107	8-759-101-37	IC UPC357C
IC108	8-759-952-07	IC SN75207BN
IC109	8-759-990-82	IC TL082CP
IC110	8-759-220-04	IC TC40H004P
IC151	8-759-990-82	IC TL082CP
IC152	8-759-900-00	IC SN74LS00N
IC153	8-759-990-82	IC TL082CP
IC154	8-759-990-82	IC TL082CP
IC155	8-759-993-53	IC LF353H
IC156	8-759-990-82	IC TL082CP
IC201	8-759-220-04	IC TC40H004P
IC202	8-759-900-86	IC SN74LS86N
IC203	8-759-990-82	IC TL082CP
IC204	8-759-900-74	IC SN74LS74AN
IC205	8-759-900-76	IC SN74LS76AN
IC209	8-759-901-28	IC MSM5128-12RS
IC210	8-759-905-50	IC CX-7933
IC211	8-759-905-52	IC CX-7934
IC212	8-759-905-53	IC CX-7935
IC213	8-759-220-74	IC TC40H074P
IC301	8-758-900-00	IC CX890
IC302	8-759-993-53	IC LF353H
IC303	8-759-240-66	IC TC4068BP

NOTE:

- Items with no part number and no description are not stocked because they are seldom required for routine service.
- Items marked "♦" are not stocked since they are seldom required for routine service. Some delay should be anticipated when ordering these items.
- Due to standardization, parts with part numbers (Δ-ΔΔΔ-ΔΔΔ-XX or Δ-ΔΔΔΔ-ΔΔΔ-X) may be different from those used in the set.

CAPACITORS:

- All capacitors are in μF. Common capacitors are omitted. Refer to the following lists for their part numbers.
MF:μF, PF:μμF.

RESISTORS

- All resistors are in ohms. Common 1/4W, 1/8W and 1/16W carbon resistors are omitted. Refer to the following lists for their part numbers.

- F: nonflammable

COILS

- MH: mH, UH: μH

The components identified by shading and mark Δ are critical for safety. Replace only with part number specified.

Les composants identifiés par une trame et une marque Δ sont critiques pour la sécurité. Ne les remplacer que par une pièce portant le numéro spécifié.

SEMICONDUCTORS

In each case, U: μ, for example:
UA...: μA...; UPA...: μPA...; UPC...: μPC
UPD...: μPD...

CDP-701ES

ELECTRICAL PARTS

Ref.No.	Part No.	Description
IC351	8-759-907-74	IC LM318H
IC371	8-759-745-56	IC NJM4556D
IC401	8-758-900-00	IC CX890
IC402	8-759-993-53	IC LF353H
IC403	8-759-240-66	IC TC4066BP
IC451	8-759-907-74	IC LM318H
IC471	8-759-745-56	IC NJM4556D
IC502	8-751-930-00	IC CX-193
IC503	8-759-745-60	IC NJM4560D
IC504	8-759-145-58	IC UPC4558C
IC601	8-759-240-69	IC TC4069UBP
IC602	8-749-969-22	IC STK-6922
IC603	8-759-240-11	IC TC4011BP
IC604	8-759-240-30	IC TC4030BP
IC605	8-759-240-11	IC TC4011BP
IC606	8-759-145-58	IC UPC4558C
IC607	8-759-745-60	IC NJM4560D
IC608	8-759-990-82	IC TL082CP
IC701	8-759-907-05	IC MB8841-1127L
IC702	8-759-907-07	IC MB8850L-127L
IC703	8-759-800-34	IC LM6416E-123
IC704	8-759-220-04	IC TC40H004P
IC705	8-759-182-43	IC UPD8243C(M)
IC706	8-759-255-01	IC TC5501P-1
IC707	8-759-182-43	IC UPD8243C(M)
IC708	8-759-240-81	IC TC4081BP
IC751	8-749-969-22	IC STK-6922
IC801	8-759-906-94	IC MB8843-1096L
IC802	8-759-907-06	IC MB8842-1128L
IC803	8-759-909-15	IC MSL915RS
IC804	8-759-909-15	IC MSL915RS
IC805	8-759-909-15	IC MSL915RS
IC806	8-759-909-15	IC MSL915RS
IC807	8-759-909-15	IC MSL915RS
IC901	8-759-907-52	IC NE5534FE
IC902	8-759-700-06	IC NJM7812B
IC903	8-759-900-72	IC NE5532P
IC904	8-759-145-84	IC UPD4584BC
IC951	8-759-907-52	IC NE5534FE
IC952	8-759-179-12	IC UPC7912H
J371	1-507-649-00	JACK, HEADPHONES
J381	1-507-852-00	JACK, PIN 2P
J471	1-507-649-00	JACK, HEADPHONES
J701	1-562-042-00	SOCKET, CONNECTOR 26P

ELECTRICAL PARTS

Ref.No.	Part No.	Description
L1	1-404-310-00	COIL
L201	1-407-569-00	COIL, VARIABLE 10UH
L701	1-408-118-00	MICRO INDUCTOR 12UH
L702	1-408-118-00	MICRO INDUCTOR 12UH
L703	1-408-118-00	MICRO INDUCTOR 12UH
L751	1-408-118-00	MICRO INDUCTOR 12UH
L901	1-421-340-00	(AEP,UK)...LINE FILTER
LF901A	1-421-597-00	(US)...LINE FILTER
LPF301	1-464-256-00	FILTER UNIT, LOW PASS
LPF401	1-464-256-00	FILTER UNIT, LOW PASS
M701	8-838-046-01	MOTOR, DC (BHR-2601A)
M702	X-4887-142-1	MOTOR ASSY, LOADING
M703	X-4884-527-1	MOTOR ASSY, CHUCKING
M704	X-4884-527-1	MOTOR ASSY, SLED
PH710	8-729-110-21	TRANSISTOR PH102
Q101	8-729-112-06	TRANSISTOR 2SA1206
Q102	8-729-112-06	TRANSISTOR 2SA1206
Q103	8-729-663-47	TRANSISTOR 2SC1364
Q104	8-729-663-47	TRANSISTOR 2SC1364
Q105	8-729-377-59	TRANSISTOR 2SC1775-F
Q106	8-729-671-12	TRANSISTOR 2SC710-12
Q201	8-729-663-47	TRANSISTOR 2SC1364
Q301	8-765-423-00	TRANSISTOR 2SK152-3
Q351	8-729-663-47	TRANSISTOR 2SC1364
Q352	8-729-204-83	TRANSISTOR 2SA1048-GR
Q401	8-765-423-00	TRANSISTOR 2SK152-3
Q451	8-729-663-47	TRANSISTOR 2SC1364
Q502	8-729-100-13	TRANSISTOR 2SC2001
Q503	8-729-100-13	TRANSISTOR 2SC2001
Q601	8-729-204-83	TRANSISTOR 2SA1048-GR
Q602	8-729-204-83	TRANSISTOR 2SA1048-GR
Q603	8-729-100-13	TRANSISTOR 2SC2001
Q604	8-729-100-13	TRANSISTOR 2SC2001
Q605	8-729-100-13	TRANSISTOR 2SC2001
Q606	8-729-245-83	TRANSISTOR 2SC2458
Q607	8-729-100-13	TRANSISTOR 2SC2001
Q608	8-729-203-04	TRANSISTOR 2SK30A
Q609	8-729-245-83	TRANSISTOR 2SC2458
Q610	8-729-245-83	TRANSISTOR 2SC2458
Q611	8-729-204-83	TRANSISTOR 2SA1048-GR
Q612	8-729-245-83	TRANSISTOR 2SC2458
Q613	8-729-245-83	TRANSISTOR 2SC2458
Q614	8-729-204-83	TRANSISTOR 2SA1048-GR
Q615	8-729-245-83	TRANSISTOR 2SC2458
Q616	8-729-245-83	TRANSISTOR 2SC2458

NOTE:

- Items with no part number and no description are not stocked because they are seldom required for routine service.
- Items marked "▲" are not stocked since they are seldom required for routine service. Some delay should be anticipated when ordering these items.
- Due to standardization, parts with part numbers (▲-▲▲▲-▲▲▲-XX or ▲-▲▲▲-▲▲▲-X) may be different from those used in the set.

CAPACITORS:

- All capacitors are in μF . Common capacitors are omitted. Refer to the following lists for their part numbers.
MF: μF , PF: μF .

RESISTORS

- All resistors are in ohms. Common 1/4W, 1/8W and 1/16W carbon resistors are omitted. Refer to the following lists for their part numbers.

- F : nonflammable

COILS

- MH : mH, UH : μH

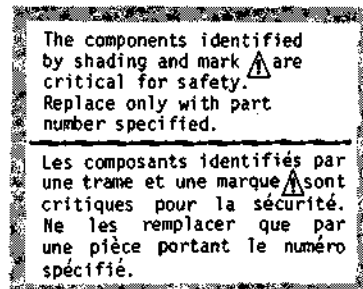

SEMICONDUCTORS

- In each case, U : μ , for example:
UA... : μA ..., UPA... : μPA ..., UPC... : μPC ,
UPD... : μPD ...

ELECTRICAL PARTS

Ref.No.	Part No.	Description
Q701	8-729-204-83	TRANSISTOR 2SA1048-GR
Q702	8-729-245-83	TRANSISTOR 2SC2458
Q705	8-729-204-83	TRANSISTOR 2SA1048-GR
Q706	8-729-204-83	TRANSISTOR 2SA1048-GR
Q707	8-729-204-83	TRANSISTOR 2SA1048-GR
Q708	8-729-204-83	TRANSISTOR 2SA1048-GR
Q709	8-729-245-83	TRANSISTOR 2SC2458
Q710	8-729-204-83	TRANSISTOR 2SA1048-GR
Q751	8-729-100-13	TRANSISTOR 2SC2001
Q752	8-729-100-13	TRANSISTOR 2SC2001
Q801	8-729-993-72	TRANSISTOR 2SA937
Q802	8-729-993-72	TRANSISTOR 2SA937
Q901	8-729-127-53	TRANSISTOR 2SC2275-P
Q902	8-729-113-82	TRANSISTOR 2SA1138
Q903	8-729-283-41	TRANSISTOR 2SB834-0
Q904	8-729-281-53	TRANSISTOR 2SC1815-GR
Q905	8-729-201-84	TRANSISTOR 2SC3112-B
Q906	8-729-113-82	TRANSISTOR 2SA1138
Q907	8-729-113-82	TRANSISTOR 2SA1138
Q908	8-769-112-00	TRANSISTOR 2SK120-2
Q951	8-729-118-53	TRANSISTOR 2SA985-P
Q952	8-729-167-62	TRANSISTOR 2SC2676
Q953	8-729-118-53	TRANSISTOR 2SA985-P
Q956	8-729-167-62	TRANSISTOR 2SC2676
Q957	8-729-167-62	TRANSISTOR 2SC2676
Q958	8-769-112-00	TRANSISTOR 2SK120-2
Q961	8-729-103-43	TRANSISTOR 2SB734
R101	1-247-824-00	CARBON 510 5% 1/6W
R102	1-247-852-00	CARBON 7.5K 5% 1/6W
R103	1-247-838-00	CARBON 2K 5% 1/6W
R104	1-247-823-00	CARBON 470 5% 1/6W
R105	1-247-852-00	CARBON 7.5K 5% 1/6W
R106	1-247-838-00	CARBON 2K 5% 1/6W
R107	1-247-823-00	CARBON 470 5% 1/6W
R108	1-247-852-00	CARBON 7.5K 5% 1/6W
R109	1-247-838-00	CARBON 2K 5% 1/6W
R110	1-247-823-00	CARBON 470 5% 1/6W
R111	1-247-852-00	CARBON 7.5K 5% 1/6W
R112	1-247-838-00	CARBON 2K 5% 1/6W
R113	1-247-823-00	CARBON 470 5% 1/6W
R114	1-247-847-00	CARBON 4.7K 5% 1/6W
R115	1-247-847-00	CARBON 4.7K 5% 1/6W
R116	1-247-847-00	CARBON 4.7K 5% 1/6W
R117	1-247-847-00	CARBON 4.7K 5% 1/6W
R118	1-247-831-00	CARBON 1K 5% 1/6W

ELECTRICAL PARTS

Ref.No.	Part No.	Description
R119	1-247-847-00	CARBON 4.7K 5% 1/6W
R120	1-247-815-00	CARBON 220 5% 1/6W
R121	1-247-855-00	CARBON 10K 5% 1/6W
R122	1-247-831-00	CARBON 1K 5% 1/6W
R123	1-247-831-00	CARBON 1K 5% 1/6W
R124	1-247-838-00	CARBON 2K 5% 1/6W
R125	1-247-839-00	CARBON 2.2K 5% 1/6W
R126	1-247-855-00	CARBON 10K 5% 1/6W
R127	1-247-839-00	CARBON 2.2K 5% 1/6W
R128	1-247-839-00	CARBON 2.2K 5% 1/6W
R129	1-247-831-00	CARBON 1K 5% 1/6W
R130	1-247-839-00	CARBON 2.2K 5% 1/6W
R131	1-247-839-00	CARBON 2.2K 5% 1/6W
R132	1-247-856-00	CARBON 11K 5% 1/6W
R133	1-247-856-00	CARBON 11K 5% 1/6W
R134	1-247-831-00	CARBON 1K 5% 1/6W
R135	1-247-855-00	CARBON 10K 5% 1/6W
R136	1-247-855-00	CARBON 10K 5% 1/6W
R137	1-247-831-00	CARBON 1K 5% 1/6W
R138	1-247-903-00	CARBON 1M 5% 1/6W
R139	1-247-855-00	CARBON 10K 5% 1/6W
R140	1-247-879-00	CARBON 100K 5% 1/6W
R141	1-247-863-00	CARBON 22K 5% 1/6W
R142	1-247-831-00	CARBON 1K 5% 1/6W
R143	1-247-855-00	CARBON 10K 5% 1/6W
R144	1-247-855-00	CARBON 10K 5% 1/6W
R145	1-247-831-00	CARBON 1K 5% 1/6W
R146	1-247-903-00	CARBON 1M 5% 1/6W
R147	1-247-863-00	CARBON 22K 5% 1/6W
R148	1-247-879-00	CARBON 100K 5% 1/6W
R149	1-214-745-00	METAL 4.7K 1% 1/4W
R150	1-214-746-00	METAL 5.1K 1% 1/4W
R151	1-247-855-00	CARBON 10K 5% 1/6W
R152	1-247-855-00	CARBON 10K 5% 1/6W
R153	1-247-855-00	CARBON 10K 5% 1/6W
R154	1-247-855-00	CARBON 10K 5% 1/6W
R155	1-247-883-00	CARBON 150K 5% 1/6W
R156	1-247-883-00	CARBON 150K 5% 1/6W
R157	1-247-831-00	CARBON 1K 5% 1/6W
R158	1-247-831-00	CARBON 1K 5% 1/6W
R159	1-247-831-00	CARBON 1K 5% 1/6W
R160	1-247-831-00	CARBON 1K 5% 1/6W
R161	1-247-855-00	CARBON 10K 5% 1/6W
R162	1-247-855-00	CARBON 10K 5% 1/6W
R163	1-247-843-00	CARBON 3.3K 5% 1/6W

NOTE:

- Items with no part number and no description are not stocked because they are seldom required for routine service.
- Items marked " * " are not stocked since they are seldom required for routine service. Some delay should be anticipated when ordering these items.
- Due to standardization, parts with part numbers (Δ-ΔΔΔ-ΔΔΔ-XX or Δ-ΔΔΔΔ-ΔΔΔ-X) may be different from those used in the set.

CAPACITORS:

- All capacitors are in μF. Common capacitors are omitted. Refer to the following lists for their part numbers. MF:μF, PF:μμF.

RESISTORS

- All resistors are in ohms. Common 1/4W, 1/8W and 1/16W carbon resistors are omitted. Refer to the following lists for their part numbers.

- * F : nonflammable

COILS

- * MMH : mH, UH : μH

The components identified by shading and mark  are critical for safety. Replace only with part number specified.

Les composants identifiés par une trame et une marque  sont critiques pour la sécurité. Ne les remplacer que par une pièce portant le numéro spécifié.

SEMICONDUCTORS

In each case, U : μ, for example:
 UA...: μA...; UPA...: μPA...; UPC...: μPC...
 UPD...: μPD...

ELECTRICAL PARTS

Ref.No.	Part No.	Description			
R164	1-247-843-00	CARBON	3.3K	5%	1/6W
R165	1-247-852-00	CARBON	7.5K	5%	1/6W
R166	1-247-852-00	CARBON	7.5K	5%	1/6W
R167	1-247-871-00	CARBON	47K	5%	1/6W
R168	1-247-871-00	CARBON	47K	5%	1/6W
R169	1-247-847-00	CARBON	4.7K	5%	1/6W
R170	1-247-847-00	CARBON	4.7K	5%	1/6W
R171	1-247-879-00	CARBON	100K	5%	1/6W
R172	1-247-831-00	CARBON	1K	5%	1/6W
R173	1-247-831-00	CARBON	1K	5%	1/6W
R174	1-247-873-00	CARBON	56K	5%	1/6W
R175	1-247-859-00	CARBON	15K	5%	1/6W
R176	1-247-847-00	CARBON	4.7K	5%	1/6W
R177	1-247-839-00	CARBON	2.2K	5%	1/6W
R178	1-247-831-00	CARBON	1K	5%	1/6W
R179	1-247-879-00	CARBON	100K	5%	1/6W
R180	1-247-895-00	CARBON	470K	5%	1/6W
R181	1-247-895-00	CARBON	470K	5%	1/6W
R182	1-247-857-00	CARBON	12K	5%	1/6W
R183	1-247-855-00	CARBON	10K	5%	1/6W
R186	1-247-839-00	CARBON	2.2K	5%	1/6W
R187	1-247-831-00	CARBON	1K	5%	1/6W
R188	1-214-764-00	METAL	30K	1%	1/4W
R189	1-247-903-00	CARBON	2M	5%	1/6W
R190	1-247-863-00	CARBON	22K	5%	1/6W
R191	1-247-871-00	CARBON	47K	5%	1/6W
R192	1-247-903-00	CARBON	1M	5%	1/6W
R193	1-247-831-00	CARBON	1K	5%	1/6W
R194	1-247-896-00	CARBON	200K	5%	1/6W
R195	1-247-886-00	CARBON	200K	5%	1/6W
R196	1-247-886-00	CARBON	200K	5%	1/6W
R197	1-247-886-00	CARBON	200K	5%	1/6W
R201	1-247-831-00	CARBON	1K	5%	1/6W
R202	1-247-831-00	CARBON	1K	5%	1/6W
R203	1-247-855-00	CARBON	10K	5%	1/6W
R204	1-247-841-00	CARBON	2.7K	5%	1/6W
R205	1-247-855-00	CARBON	10K	5%	1/6W
R206	1-247-853-00	CARBON	8.2K	5%	1/6W
R207	1-247-831-00	CARBON	1K	5%	1/6W
R208	1-247-855-00	CARBON	10K	5%	1/6W
R209	1-247-831-00	CARBON	1K	5%	1/6W
R210	1-247-879-00	CARBON	100K	5%	1/6W
R211	1-247-879-00	CARBON	100K	5%	1/6W
R212	1-247-846-00	CARBON	4.3K	5%	1/6W
R213	1-247-879-00	CARBON	100K	5%	1/6W

ELECTRICAL PARTS

Ref.No.	Part No.	Description			
R232	1-247-863-00	CARBON	22K	5%	1/6W
R233	1-247-855-00	CARBON	10K	5%	1/6W
R235	1-247-831-00	CARBON	1K	5%	1/6W
R236	1-247-831-00	CARBON	1K	5%	1/6W
R237	1-247-855-00	CARBON	10K	5%	1/6W
R238	1-247-855-00	CARBON	10K	5%	1/6W
R239	1-247-855-00	CARBON	10K	5%	1/6W
R240	1-247-855-00	CARBON	10K	5%	1/6W
R301	1-247-807-00	CARBON	100	5%	1/6W
R302	1-214-874-00	METAL	2.7K	1%	1/2W
R303	1-214-907-00	METAL	56K	1%	1/2W
R304	1-247-863-00	CARBON	22K	5%	1/6W
R305	1-214-888-00	METAL	10K	1%	1/2W
R306	1-247-863-00	CARBON	22K	5%	1/6W
R307	1-214-892-00	METAL	15K	1%	1/2W
R308	1-214-888-00	METAL	10K	1%	1/2W
R309	1-214-872-00	METAL	2.2K	1%	1/2W
R331	1-247-847-00	CARBON	4.7K	5%	1/6W
R332	1-247-855-00	CARBON	10K	5%	1/6W
R354	1-215-501-00	METAL	5.6K	1%	1W
R355	1-214-937-00	METAL	1M	1%	1/2W
R356	1-215-234-00	METAL	11K	1%	1W
R357	1-214-855-00	METAL	430	1%	1/2W
R359	1-214-844-00	METAL	150	1%	1/2W
R360	1-214-848-00	METAL	220	1%	1/2W
R361	1-214-929-00	METAL	470K	1%	1/2W
R362	1-214-901-00	METAL	33K	1%	1/2W
R372	1-214-158-00	METAL	12K	1%	1/4W
R373	1-214-151-00	METAL	6.2K	1%	1/4W
R374	1-214-143-00	METAL	3K	1%	1/4W
R375	1-214-136-00	METAL	1.5K	1%	1/4W
R376	1-214-136-00	METAL	1.5K	1%	1/4W
R377	1-214-180-00	METAL	100K	1%	1/4W
R378	1-214-148-00	METAL	4.7K	1%	1/4W
R379	1-214-171-00	METAL	43K	1%	1/4W
R380	1-214-116-00	METAL	220	1%	1/4W
R381	1-214-108-00	METAL	100	1%	1/4W
R401	1-247-807-00	CARBON	100	5%	1/6W
R402	1-214-874-00	METAL	2.7K	1%	1/2W
R403	1-214-908-00	METAL	62K	1%	1/2W
R404	1-247-863-00	CARBON	22K	5%	1/6W
R405	1-214-888-00	METAL	10K	1%	1/2W
R406	1-247-863-00	CARBON	22K	5%	1/6W
R407	1-214-892-00	METAL	15K	1%	1/2W

NOTE:

- Items with no part number and no description are not stocked because they are seldom required for routine service.
- Items marked " * " are not stocked since they are seldom required for routine service. Some delay should be anticipated when ordering these items.
- Due to standardization, parts with part numbers (Δ-ΔΔΔ-ΔΔΔ-XX or Δ-ΔΔΔΔ-ΔΔΔ-X) may be different from those used in the set.

CAPACITORS:

- All capacitors are in μF. Common capacitors are omitted. Refer to the following lists for their part numbers. MF:μF, PF:μμF.

RESISTORS

- All resistors are in ohms. Common 1/4W, 1/8W and 1/16W carbon resistors are omitted. Refer to the following lists for their part numbers.

- F : nonflammable

COILS

- MH : mH, UH : μH

The components identified by shading and mark **▲** are critical for safety. Replace only with part number specified.

Les composants identifiés par une trame et une marque **▲** sont critiques pour la sécurité. Ne les remplacer que par une pièce portant le numéro spécifié.

SEMICONDUCTORS

- In each case, U : μ, for example: UA...: μA..., UPA...: μPA..., UPC...: μPC, UPD...: μPD...

ELECTRICAL PARTS

Ref.No.	Part No.	Description			
R408	1-214-888-00	METAL	10K	1%	1/2W
R409	1-214-872-00	METAL	2.2K	1%	1/2W
R431	1-247-855-00	CARBON	10K	5%	1/6W
R432	1-247-855-00	CARBON	10K	5%	1/6W
R454	1-215-501-00	METAL	5.6K	1%	1M
R455	1-214-937-00	METAL	1M	1%	1/2W
R456	1-215-234-00	METAL	11K	1%	1M
R457	1-214-855-00	METAL	430	1%	1/2W
R459	1-214-844-00	METAL	150	1%	1/2W
R460	1-214-848-00	METAL	220	1%	1/2W
R461	1-214-929-00	METAL	470K	1%	1/2W
R462	1-214-901-00	METAL	33K	1%	1/2W
R472	1-214-158-00	METAL	12K	1%	1/4W
R473	1-214-151-00	METAL	6.2K	1%	1/4W
R474	1-214-143-00	METAL	3K	1%	1/4W
R475	1-214-136-00	METAL	1.5K	1%	1/4W
R476	1-214-136-00	METAL	1.5K	1%	1/4W
R477	1-214-180-00	METAL	100K	1%	1/4W
R478	1-214-148-00	METAL	4.7K	1%	1/4W
R479	1-214-171-00	METAL	47K	1%	1/4W
R480	1-214-116-00	METAL	220	1%	1/4W
R481	1-214-108-00	METAL	100	1%	1/4W
R510	1-247-831-00	CARBON	1K	5%	1/6W
R511	1-247-863-00	CARBON	22K	5%	1/6W
R512	1-247-851-00	CARBON	6.8K	5%	1/6W
R513	1-247-855-00	CARBON	10K	5%	1/6W
R514	1-247-855-00	CARBON	10K	5%	1/6W
R515	1-214-779-00	METAL	120K	1%	1/4W
R516	1-247-875-00	CARBON	68K	5%	1/6W
R517	1-247-877-00	CARBON	82K	5%	1/6W
R518	1-247-859-00	CARBON	15K	5%	1/6W
R519	1-247-871-00	CARBON	47K	5%	1/6W
R520	1-247-871-00	CARBON	47K	5%	1/6W
R521	1-247-871-00	CARBON	47K	5%	1/6W
R522	1-247-859-00	CARBON	15K	5%	1/6W
R523	1-247-859-00	CARBON	15K	5%	1/6W
R524	1-247-869-00	CARBON	39K	5%	1/6W
R525	1-247-869-00	CARBON	39K	5%	1/6W
R526	1-244-852-00	CARBON	130	5%	1/2W
R528	△ 1-212-942-00	FUSIBLE	2.2	5%	1/2W F
R529	△ 1-212-942-00	FUSIBLE	2.2	5%	1/2W F
R532	1-247-879-00	CARBON	100K	5%	1/6W
R533	1-214-757-00	METAL	15K	1%	1/4W
R534	1-247-871-00	CARBON	47K	5%	1/6W
R535	1-214-753-00	METAL	10K	1%	1/4W

ELECTRICAL PARTS

Ref.No.	Part No.	Description			
R536	1-214-739-00	METAL	2.7K	1%	1/4W
R537	1-247-895-00	CARBON	470K	5%	1/6W
R538	1-214-759-00	METAL	18K	1%	1/4W
R539	1-247-843-00	CARBON	3.3K	5%	1/6W
R540	1-247-903-00	CARBON	1M	5%	1/6W
R541	1-247-831-00	CARBON	1K	5%	1/6W
R542	1-247-855-00	CARBON	10K	5%	1/6W
R543	1-247-857-00	CARBON	12K	5%	1/6W
R545	1-247-867-00	CARBON	33K	5%	1/6W
R546	1-247-839-00	CARBON	2.2K	5%	1/6W
R547	1-247-855-00	CARBON	10K	5%	1/6W
R548	1-247-855-00	CARBON	10K	5%	1/6W
R549	1-247-831-00	CARBON	1K	5%	1/6W
R550	1-247-831-00	CARBON	1K	5%	1/6W
R551	1-247-873-00	CARBON	56K	5%	1/6W
R601	1-247-871-00	CARBON	47K	5%	1/6W
R602	1-247-863-00	CARBON	22K	5%	1/6W
R603	1-247-855-00	CARBON	10K	5%	1/6W
R604	1-247-875-00	CARBON	68K	5%	1/6W
R605	1-247-889-00	CARBON	270K	5%	1/6W
R606	1-247-863-00	CARBON	22K	5%	1/6W
R607	1-247-855-00	CARBON	10K	5%	1/6W
R608	1-247-859-00	CARBON	15K	5%	1/6W
R609	1-247-839-00	CARBON	2.2K	5%	1/6W
R610	1-247-863-00	CARBON	22K	5%	1/6W
R611	1-247-855-00	CARBON	10K	5%	1/6W
R612	1-247-855-00	CARBON	10K	5%	1/6W
R613	1-247-855-00	CARBON	10K	5%	1/6W
R614	1-247-855-00	CARBON	10K	5%	1/6W
R615	1-247-849-00	CARBON	5.6K	5%	1/6W
R616	1-247-869-00	CARBON	39K	5%	1/6W
R617	1-247-883-00	CARBON	150K	5%	1/6W
R618	1-247-815-00	CARBON	220	5%	1/6W
R619	1-247-855-00	CARBON	10K	5%	1/6W
R620	1-247-839-00	CARBON	2.2K	5%	1/6W
R622	1-247-839-00	CARBON	2.2K	5%	1/6W
R623	1-247-863-00	CARBON	22K	5%	1/6W
R624	1-247-855-00	CARBON	10K	5%	1/6W
R625	1-247-863-00	CARBON	22K	5%	1/6W
R626	1-247-877-00	CARBON	82K	5%	1/6W
R627	1-247-855-00	CARBON	10K	5%	1/6W
R628	1-247-855-00	CARBON	10K	5%	1/6W
R629	1-247-855-00	CARBON	10K	5%	1/6W
R630	1-247-843-00	CARBON	3.3K	5%	1/6W

NOTE:

- Items with no part number and no description are not stocked because they are seldom required for routine service.
- Items marked "△" are not stocked since they are seldom required for routine service. Some delay should be anticipated when ordering these items.
- Due to standardization, parts with part numbers (Δ-ΔΔΔ-ΔΔΔ-XX or Δ-ΔΔΔΔ-ΔΔΔ-X) may be different from those used in the set.

CAPACITORS:

- All capacitors are in μF . Common capacitors are omitted. Refer to the following lists for their part numbers.
- MF: μF , PF: μpF .

RESISTORS

- All resistors are in ohms. Common 1/4W, 1/8W and 1/16W carbon resistors are omitted. Refer to the following lists for their part numbers.
- F: nonflammable

COILS

- MH: mH, UH: μH

The components identified by shading and mark Δ are critical for safety. Replace only with part number specified.

Les composants identifiés par une trame et une marque Δ sont critiques pour la sécurité. Ne les remplacer que par une pièce portant le numéro spécifié.

SEMICONDUCTORS

- In each case, U: μ , for example:
 UA...: μA ...; UPA...: μPA ...; UPC...: μPC
 UPD...: μPD ...

ELECTRICAL PARTS

Ref.No.	Part No.	Description			
R631	1-247-855-00	CARBON	10K	5%	1/6W
R632	1-247-855-00	CARBON	10K	5%	1/6W
R633	1-247-903-00	CARBON	1M	5%	1/6W
R634	1-247-855-00	CARBON	10K	5%	1/6W
R635	1-247-857-00	CARBON	12K	5%	1/6W
R636	1-247-863-00	CARBON	22K	5%	1/6W
R637	1-247-863-00	CARBON	22K	5%	1/6W
R638	1-247-878-00	CARBON	91K	5%	1/6W
R639	1-247-878-00	CARBON	91K	5%	1/6W
R640	1-247-855-00	CARBON	10K	5%	1/6W
R641	1-247-863-00	CARBON	22K	5%	1/6W
R642	1-247-875-00	CARBON	68K	5%	1/6W
R643	1-247-875-00	CARBON	68K	5%	1/6W
R644	1-247-871-00	CARBON	47K	5%	1/6W
R645	1-247-855-00	CARBON	10K	5%	1/6W
R646	1-247-877-00	CARBON	82K	5%	1/6W
R647	1-247-839-00	CARBON	2.2K	5%	1/6W
R648	1-247-863-00	CARBON	22K	5%	1/6W
R649	1-247-879-00	CARBON	100K	5%	1/6W
R650	1-247-903-00	CARBON	1M	5%	1/6W
R651	1-247-855-00	CARBON	10K	5%	1/6W
R652	1-247-839-00	CARBON	2.2K	5%	1/6W
R653	1-247-903-00	CARBON	1M	5%	1/6W
R654	1-247-871-00	CARBON	47K	5%	1/6W
R655	1-247-855-00	CARBON	10K	5%	1/6W
R656	1-247-855-00	CARBON	10K	5%	1/6W
R657	1-247-839-00	CARBON	2.2K	5%	1/6W
R658	1-247-855-00	CARBON	10K	5%	1/6W
R659	1-247-855-00	CARBON	10K	5%	1/6W
R660	1-247-903-00	CARBON	1M	5%	1/6W
R661	1-247-861-00	CARBON	18K	5%	1/6W
R662	1-247-879-00	CARBON	100K	5%	1/6W
R663	1-247-815-00	CARBON	220	5%	1/6W
R664	1-247-879-00	CARBON	100K	5%	1/6W
R665	1-247-903-00	CARBON	1M	5%	1/6W
R666	1-247-903-00	CARBON	1M	5%	1/6W
R667	1-247-879-00	CARBON	100K	5%	1/6W
R668	1-247-819-00	CARBON	330	5%	1/6W
R669	1-247-831-00	CARBON	1K	5%	1/6W
R670	1-247-855-00	CARBON	10K	5%	1/6W
R671	1-247-887-00	CARBON	220K	5%	1/6W
R672	1-247-887-00	CARBON	220K	5%	1/6W
R673	1-247-891-00	CARBON	330K	5%	1/6W
R674	1-247-903-00	CARBON	1M	5%	1/6W
R675	1-247-903-00	CARBON	1M	5%	1/6W

ELECTRICAL PARTS

Ref.No.	Part No.	Description			
R676	1-247-857-00	CARBON	12K	5%	1/6W
R677	1-247-855-00	CARBON	10K	5%	1/6W
R678	1-247-831-00	CARBON	1K	5%	1/6W
R679	1-247-855-00	CARBON	10K	5%	1/6W
R680	1-247-867-00	CARBON	33K	5%	1/6W
R701	1-247-835-00	CARBON	1.5K	5%	1/6W
R703	1-247-903-00	CARBON	1M	5%	1/6W
R704	1-247-875-00	CARBON	68K	5%	1/6W
R705	1-247-807-00	CARBON	100	5%	1/6W
R706	1-247-903-00	CARBON	1M	5%	1/6W
R707	1-247-863-00	CARBON	22K	5%	1/6W
R708	1-247-863-00	CARBON	22K	5%	1/6W
R709	1-247-879-00	CARBON	100K	5%	1/6W
R710	1-247-859-00	CARBON	15K	5%	1/6W
R711	1-247-855-00	CARBON	10K	5%	1/6W
R712	1-247-863-00	CARBON	22K	5%	1/6W
R713	1-247-863-00	CARBON	22K	5%	1/6W
R714	1-247-863-00	CARBON	22K	5%	1/6W
R715	1-247-863-00	CARBON	22K	5%	1/6W
R716	1-247-863-00	CARBON	22K	5%	1/6W
R717	1-247-863-00	CARBON	22K	5%	1/6W
R718	1-247-847-00	CARBON	4.7K	5%	1/6W
R719	1-247-811-00	CARBON	150	5%	1/6W
R720	1-247-811-00	CARBON	150	5%	1/6W
R721	1-247-811-00	CARBON	150	5%	1/6W
R722	1-247-819-00	CARBON	330	5%	1/6W
R723	1-247-811-00	CARBON	150	5%	1/6W
R724	1-247-843-00	CARBON	3.3K	5%	1/6W
R725	1-247-819-00	CARBON	330	5%	1/6W
R726	1-247-869-00	CARBON	39K	5%	1/6W
R727	1-247-863-00	CARBON	22K	5%	1/6W
R728	1-247-863-00	CARBON	22K	5%	1/6W
R729	1-247-855-00	CARBON	10K	5%	1/6W
R734	1-247-831-00	CARBON	1K	5%	1/6W
R735	1-247-811-00	CARBON	150	5%	1/6W
R736	1-247-863-00	CARBON	22K	5%	1/6W
R737	1-247-863-00	CARBON	22K	5%	1/6W
R738	1-247-863-00	CARBON	22K	5%	1/6W
R739	1-247-863-00	CARBON	22K	5%	1/6W
R740	1-247-819-00	CARBON	330	5%	1/6W
R741	1-247-847-00	CARBON	4.7K	5%	1/6W
R742	1-247-847-00	CARBON	4.7K	5%	1/6W
R743	1-247-863-00	CARBON	22K	5%	1/6W
R744	1-247-863-00	CARBON	22K	5%	1/6W
R751	1-247-879-00	CARBON	100K	5%	1/6W

NOTE:

- Items with no part number and no description are not stocked because they are seldom required for routine service.
- Items marked " * " are not stocked since they are seldom required for routine service. Some delay should be anticipated when ordering these items.
- Due to standardization, parts with part numbers (Δ-ΔΔΔ-ΔΔΔ-XX or Δ-ΔΔΔΔ-ΔΔΔ-X) may be different from those used in the set.

CAPACITORS:

- All capacitors are in μF. Common capacitors are omitted. Refer to the following lists for their part numbers. MF:μF, PF:μμF.

RESISTORS

- All resistors are in ohms. Common 1/4W, 1/8W and 1/16W carbon resistors are omitted. Refer to the following lists for their part numbers.

- F : nonflammable

COILS

- MMH : mH, UH : μH

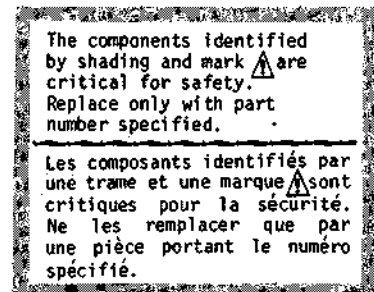

SEMICONDUCTORS

- In each case, U : μ , for example: UA... : μ A..., UPA... : μ PA..., UPC... : μ PC, UPD... : μ PD...

ELECTRICAL PARTS

Ref.No.	Part No.	Description			
R752	1-247-851-00	CARBON	6.8K	5%	1/6W
R753	1-247-863-00	CARBON	22K	5%	1/6W
R754	1-247-875-00	CARBON	68K	5%	1/6W
R755	1-247-847-00	CARBON	4.7K	5%	1/6W
R756	1-247-875-00	CARBON	68K	5%	1/6W
R757	1-247-839-00	CARBON	2.2K	5%	1/6W
R758	1-247-871-00	CARBON	47K	5%	1/6W
R759	1-247-871-00	CARBON	47K	5%	1/6W
R760	1-247-885-00	CARBON	180K	5%	1/6W
R761	1-247-885-00	CARBON	180K	5%	1/6W
R762	1-247-835-00	CARBON	1.5K	5%	1/6W
R763	1-247-903-00	CARBON	1M	5%	1/6W
R764	1-247-871-00	CARBON	47K	5%	1/6W
R765	1-247-879-00	CARBON	100K	5%	1/6W
R781	1-247-807-00	CARBON	100	5%	1/6W
R782	1-247-807-00	CARBON	100	5%	1/6W
R783	1-247-807-00	CARBON	100	5%	1/6W
R801	1-247-855-00	CARBON	10K	5%	1/6W
R802	1-247-855-00	CARBON	10K	5%	1/6W
R803	1-247-855-00	CARBON	10K	5%	1/6W
R804	1-247-855-00	CARBON	10K	5%	1/6W
R805	1-247-855-00	CARBON	10K	5%	1/6W
R806	1-247-855-00	CARBON	10K	5%	1/6W
R807	1-247-871-00	CARBON	47K	5%	1/6W
R808	1-247-871-00	CARBON	47K	5%	1/6W
R809	1-247-847-00	CARBON	4.7K	5%	1/6W
R810	1-247-847-00	CARBON	4.7K	5%	1/6W
R901	1-214-848-00	METAL	220	1%	1/2W
R902	1-214-864-00	METAL	1K	1%	1/2W
R903	1-214-852-00	METAL	330	1%	1/2W
R904	1-214-880-00	METAL	4.7K	1%	1/2W
R905	1-215-234-00	METAL	11K	1%	1W
R906	1-215-234-00	METAL	11K	1%	1W
R907	1-214-848-00	METAL	220	1%	1/2W
R908	1-214-905-00	METAL	47K	1%	1/2W
R909	1-214-753-00	METAL	10K	1%	1/4W
R910	1-213-062-00	FUSIBLE	12	5%	1W F
R911	1-247-831-00	CARBON	1K	5%	1/6W
R912	1-247-846-00	CARBON	4.3K	5%	1/6W
R913	1-247-843-00	CARBON	3.3K	5%	1/6W
R914	1-247-852-00	CARBON	7.5K	5%	1/6W
R915	1-247-855-00	CARBON	10K	5%	1/6W
R916	1-247-884-00	CARBON	160K	5%	1/6W
R917	1-247-799-00	CARBON	47	5%	1/6W
R918	1-213-026-00	(AEP, UK) FUSIBLE	1	5%	1W F

ELECTRICAL PARTS

Ref.No.	Part No.	Description			
R919	1-212-934-00	(AEP, UK) FUSIBLE	1	5%	1/2W F
R951	1-214-848-00	METAL	220	1%	1/2W
R952	1-214-864-00	METAL	1K	1%	1/2W
R953	1-214-852-00	METAL	330	1%	1/2W
R954	1-214-880-00	METAL	4.7K	1%	1/2W
R955	1-215-234-00	METAL	11K	1%	1W
R956	1-215-234-00	METAL	11K	1%	1W
R957	1-214-848-00	METAL	220	1%	1/2W
R958	1-214-905-00	METAL	47K	1%	1/2W
R959	1-214-753-00	METAL	10K	1%	1/4W
R960	1-213-071-00	FUSIBLE	30	5%	1W F
R961	1-212-857-00	FUSIBLE	10	5%	1/4W F
R962	1-246-477-00	CARBON	1.5K	5%	1/4W
R963	1-247-855-00	CARBON	10K	5%	1/6W
R964	1-212-934-00	(AEP, UK) FUSIBLE	3.3	5%	1/2W F
R969	1-212-946-00	(AEP, UK) FUSIBLE	3.3	5%	1/2W F
R981	1-214-929-00	(AEP, UK) METAL	470K	1%	1/2W
RV101	1-226-703-00	RES, ADJ, METAL GLAZE	10K		
RV151	1-226-772-00	RES, ADJ, METAL GLAZE	4.7K		
RV152	1-226-703-00	RES, ADJ, METAL GLAZE	10K		
RV153	1-226-772-00	RES, ADJ, METAL GLAZE	4.7K		
RV201	1-226-703-00	RES, ADJ, METAL GLAZE	10K		
RV301	1-224-252-XX	RES, ADJ, METAL GLAZE	10K		
RV302	1-224-252-XX	RES, ADJ, METAL GLAZE	10K		
RV402	1-224-252-XX	RES, ADJ, METAL GLAZE	10K		
RV502	1-226-775-00	RES, ADJ, METAL GLAZE	100K		
RV503	1-226-773-00	RES, ADJ, METAL GLAZE	22K		
RV602	1-226-703-00	RES, ADJ, METAL GLAZE	10K		
RV603	1-226-703-00	RES, ADJ, METAL GLAZE	10K		
RV604	1-226-775-00	RES, ADJ, METAL GLAZE	100K		
RY351	1-515-457-00	RELAY			
RY451	1-515-495-00	RELAY			
S371	1-553-307-21	SWITCH, ROTARY, ATT			
S471	1-553-307-21	SWITCH, ROTARY, ATT			
S701	1-552-849-00	SWITCH, SLIDE, CLV			
S702	1-554-205-00	SWITCH, PUSH, LIMIT			
S703	1-554-420-00	SWITCH, PUSH, CHUCKING DET			
S704	1-554-420-00	SWITCH, PUSH, DISC TABLE POSITION DET			
S705	1-516-777-XX	SLIDE SWITCH, BEEP			
S706	1-554-421-00	SWITCH, SLIDE, TIMER			
S707	1-554-205-00	SWITCH, PUSH, CHUCKING MOTOR			
S708	1-553-636-00	SWITCH, MICRO, MOTOR SELECT			
S709	1-554-205-00	SWITCH, PUSH, LASER ON			
S710	1-554-420-00	SWITCH, PUSH, LASER ON			

NOTE:

- Items with no part number and no description are not stocked because they are seldom required for routine service.
- Items marked "▲" are not stocked since they are seldom required for routine service. Some delay should be anticipated when ordering these items.
- Due to standardization, parts with part numbers (Δ-ΔΔΔ-ΔΔΔ-XX or Δ-ΔΔΔΔ-ΔΔΔ-X) may be different from those used in the set.

CAPACITORS:

- All capacitors are in μF. Common capacitors are omitted. Refer to the following lists for their part numbers. MF: μF, PF: pF.

RESISTORS

- All resistors are in ohms. Common 1/4W, 1/8W and 1/16W carbon resistors are omitted. Refer to the following lists for their part numbers.

- F: nonflammable

COILS

- MMH: mH, UH: μH

The components identified by shading and mark ▲ are critical for safety. Replace only with part number specified.

Les composants identifiés par une trame et une marque ▲ sont critiques pour la sécurité. Ne les remplacer que par une pièce portant le numéro spécifié.

SEMICONDUCTORS

- In each case, U: μ, for example:
 UA...: μA...; UPA...: μPA...; UPC...: μPC...
 UPD...: μPD...

ELECTRICAL PARTS

Ref.No.	Part No.	Description
S711	1-553-856-00	SWITCH, KEY BOARD, OPEN/CLOSE
S851	1-553-856-00	SWITCH, KEY BOARD
S852	1-553-856-00	SWITCH, KEY BOARD
S853	1-553-856-00	SWITCH, KEY BOARD
S854	1-553-856-00	SWITCH, KEY BOARD
S855	1-553-856-00	SWITCH, KEY BOARD
S856	1-553-856-00	SWITCH, KEY BOARD
S857	1-553-856-00	SWITCH, KEY BOARD
S858	1-553-856-00	SWITCH, KEY BOARD
S859	1-553-856-00	SWITCH, KEY BOARD
S860	1-553-856-00	SWITCH, KEY BOARD
S861	1-553-856-00	SWITCH, KEY BOARD
S862	1-553-856-00	SWITCH, KEY BOARD
S863	1-553-856-00	SWITCH, KEY BOARD
S864	1-553-856-00	SWITCH, KEY BOARD
S871	1-553-856-00	SWITCH, KEY BOARD
S872	1-553-856-00	SWITCH, KEY BOARD
S873	1-553-856-00	SWITCH, KEY BOARD
S874	1-553-856-00	SWITCH, KEY BOARD
S875	1-553-856-00	SWITCH, KEY BOARD
S876	1-553-856-00	SWITCH, KEY BOARD
S877	1-553-856-00	SWITCH, KEY BOARD
S878	1-553-856-00	SWITCH, KEY BOARD
S879	1-553-856-00	SWITCH, KEY BOARD

ELECTRICAL PARTS

Ref.No.	Part No.	Description
S880	1-553-856-00	SWITCH, KEY BOARD
S881	1-553-856-00	SWITCH, KEY BOARD
S882	1-553-856-00	SWITCH, KEY BOARD
S883	1-553-856-00	SWITCH, KEY BOARD
S884	1-553-856-00	SWITCH, KEY BOARD
S885	1-553-856-00	SWITCH, KEY BOARD
S886	1-553-856-00	SWITCH, KEY BOARD
S887	1-553-856-00	SWITCH, KEY BOARD
S888	1-553-856-00	SWITCH, KEY BOARD
S901	△.1-553-318-00	(AEP,UK)...SWITCH, PUSH(AC POWER), POWER
S901	△.1-553-319-00	(US,Canadian)...SWITCH, PUSH, POWER
T201	1-426-106-00	TRANSFORMER, RF
T901	△.1-447-648-00	(US,Canadian)...TRANSFORMER, POWER
T901	△.1-447-649-00	(AEP,UK)...TRANSFORMER, POWER
V801	1-519-287-00	INDICATOR TUBE, FLUORESCENT
X201	1-527-999-00	OSCILLATOR, CRYSTAL
X202	1-527-948-00	VIBRATOR, CRYSTAL
X701	1-527-380-21	CRYSTAL, OSC
X702	1-527-895-00	OSCILLATOR, CERAMIC

NOTE:

- Items with no part number and no description are not stocked because they are seldom required for routine service.
- Items marked "△" are not stocked since they are seldom required for routine service. Some delay should be anticipated when ordering these items.
- Due to standardization, parts with part numbers (△-△△△-△△△-XX or △-△△△△-△△△-X) may be different from those used in the set.

CAPACITORS:

- All capacitors are in μF . Common capacitors are omitted. Refer to the following lists for their part numbers.
MF: μF , PF: μpF .

RESISTORS

- All resistors are in ohms. Common 1/4W, 1/8W and 1/16W carbon resistors are omitted. Refer to the following lists for their part numbers.

- F : nonflammable

COILS

- MH : mH, UH : μH

The components identified by shading and mark △ are critical for safety. Replace only with part number specified.

Les composants identifiés par une trame et une marque △ sont critiques pour la sécurité. Ne les remplacer que par une pièce portant le numéro spécifié.

SEMICONDUCTORS

- In each case, U : μ , for example:
UA...: μA ...; UPA...: μPA ...; UPC...: μPC ...
UPD...: μPD ...

RM-101

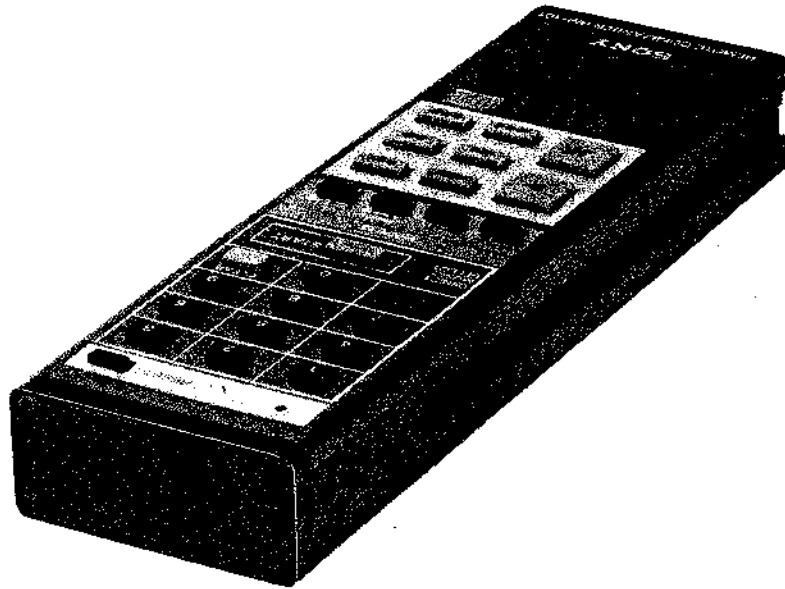

REMOTE COMMANDER

SPECIFICATIONS

Remote control system	Infrared control
Power requirements	3 V dc with two batteries IEC designation R6 (size AA)
Dimensions	Approx. 55 × 175 × 26 mm (w/h/d) (2 ¹ / ₄ × 7 × 1 ¹ / ₁₆ inches) incl. projecting parts and controls
Weight	Approx. 150 g (5.3 oz)

RM-101

1. OPERATIONS

Function of keys on the Remote Commander

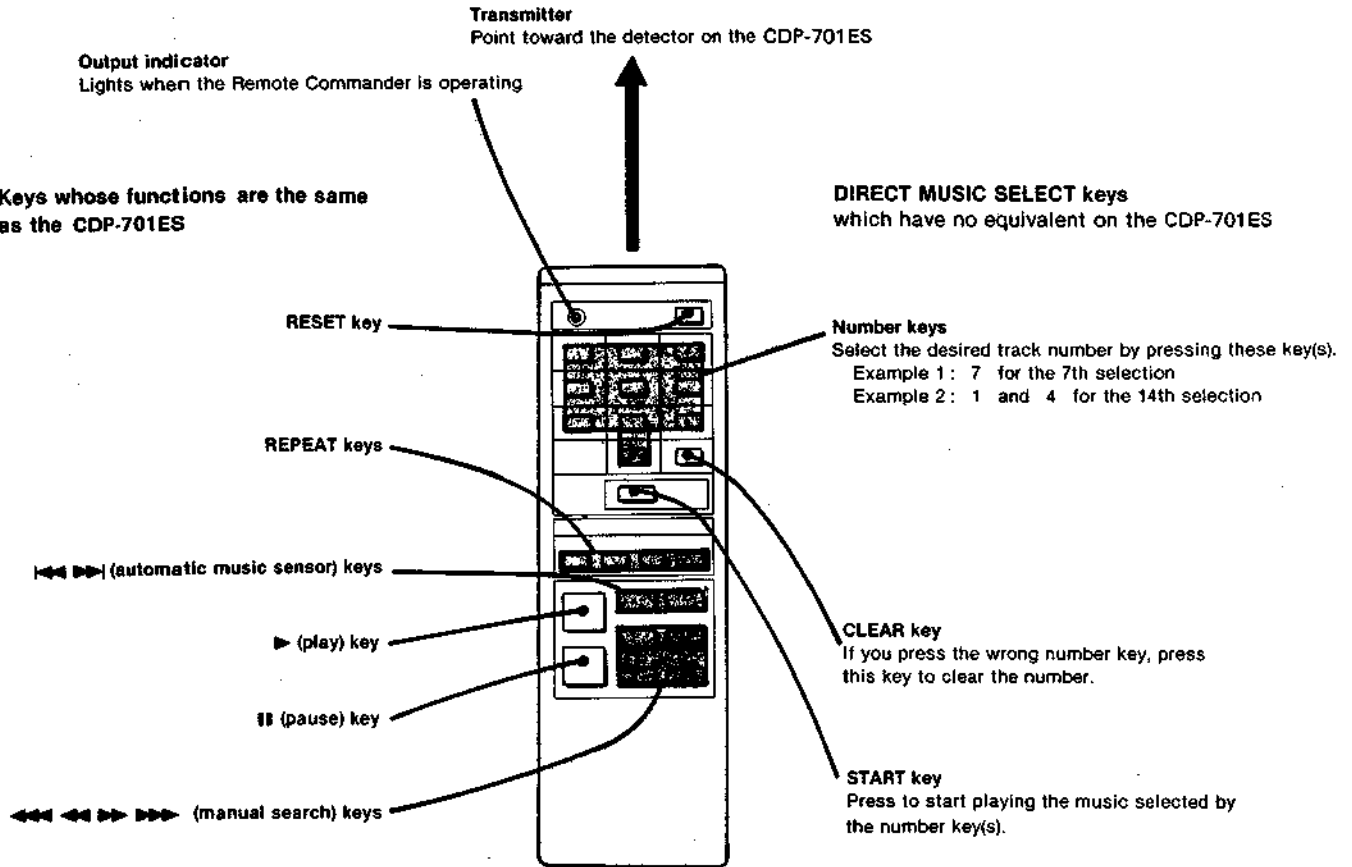

Notes on DIRECT MUSIC SELECT keys operation

- After you select the track number with the number keys, press the START key immediately. If you do not press the START key within a few seconds, or if you press any other key, the selected number is automatically cancelled.
- If you select a track number which is not available on the disc, the selected number is cancelled when the START key is pressed.
- When the AUTO PAUSE switch is set to ON, the player will be in the pause mode after playing each selection. The auto pause mode is released when the START key on the Remote Commander is pressed.

Range of the remote control

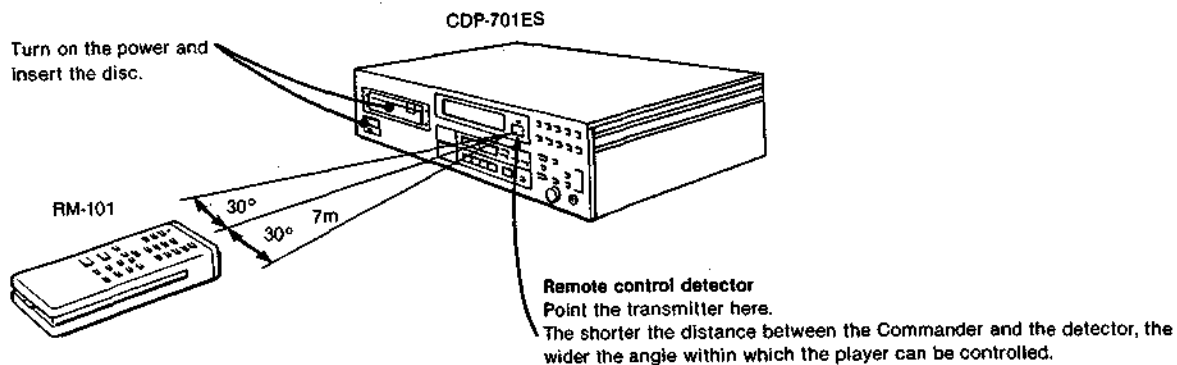

Notes on the Remote Commander

- In normal operation, battery life is up to half a year. When the battery is exhausted, the Remote Commander will not operate the unit. In this case, replace the batteries with new ones.
- When the Commander is not to be used for a long period of time, remove the batteries to avoid damage from possible battery leakage.
- Keep the Commander away from extremely hot or humid places.
- Avoid dropping any foreign objects into the Commander cabinet, particularly when replacing batteries.
- To avoid a malfunction, do not simultaneously depress two or more keys.
- If the output indicator does not light when any of the function keys are pressed, replace all the batteries.

2. DISASSEMBLY

- Follow the disassembly procedure in the numerical order given.

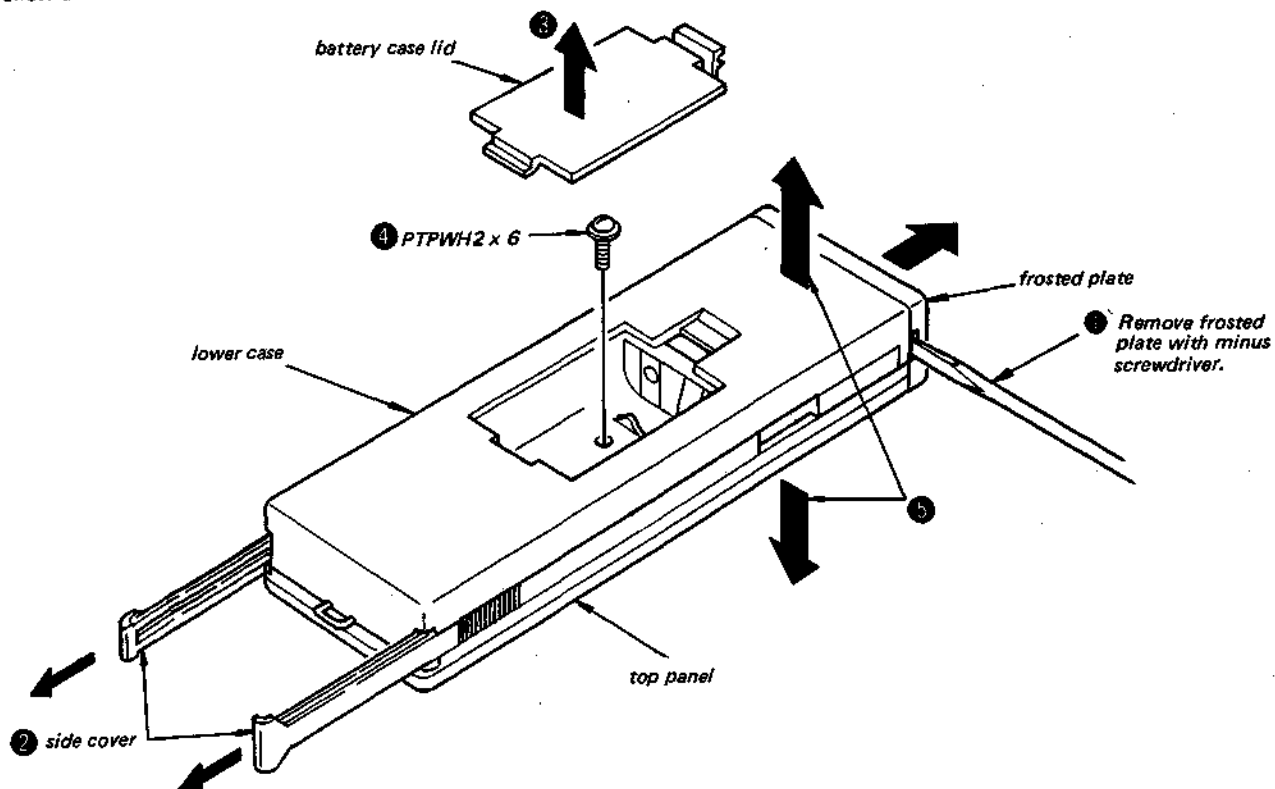

3. CIRCUIT DESCRIPTION

● **CX7947**

3-1. Summary

CX7947 is a power consumption reduction-type remote control LSI. When no key input exists, it can be initialized by stopping the clock.

On this model, if a function key is not pressed, it is in the initial state and the IC pins maintain the following states.

- 1) IC state for initial state
 - clock stopped
 - key output pins (KO1 – KO8) maintain level "1"
 - remote control output (IR) pins maintain level "0"
 - indication output (IND) pins maintain level "1"

2) Release of initial state

The initial state is immediately released when there is input to the key input pins.

3) Clock on/off

The clock oscillation is stopped for initial state only. When a switch is turned on from initial state, the clock begins oscillating within 10 msec.

Once oscillation begins, even if key input stops right away, oscillation continues for 9.0 ms, then it returns to initial state and oscillation stops.

Oscillation continues while key input continues or during remote control output.

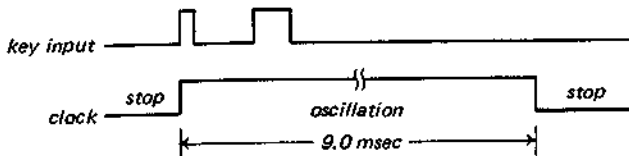

4) Clock oscillation stopped state

- CL1 pin: maintained at VDD level inside IC
- CL2 pin: level "1" output

3-2. Pin Function Description

Pin No.	Pin Name	Function	Type
1	KI5	key input	IN
2	KI4	key input	IN
3	KI3	key input	IN
4	KI2	key input	IN
5	KI1	key input	IN
6	IND	indication output	OUT
7	CL1	oscillation input	IN
8	CL2	oscillation output	OUT
9	KO1	key output	OUT
10	KO2	key output	OUT
11	KO3	key output	OUT
12	KO4	key output	OUT
13	KO5	key output	OUT

Pin No.	Pin Name	Function	Type
14	VSS	GND	-
15	KO6	key output	OUT
16	KO7	key output	OUT
17	KO8	key output	OUT
18	IR	remote control output	OUT
19	MD5	mode switching	IN
20	MD4	mode switching	IN
21	MD3	mode switching	IN
22	MD2	mode switching	IN
23	MD1	mode switching	IN
24	MD0	mode switching	IN
25	KI8	key input	IN
26	KI7	key input	IN
27	KI6	key input	IN
28	VDD	power supply	-

3-3. Data Code

- Each switch is connected to one pin of the key matrix output pins (KO1 – KO8) and one pin of the key matrix input pins (KI1 – KI8). The data codes for each switch have the following relationships depending on to which pin each switch is connected.

Key output	Data code			Key input	Data code		
	2 ⁵	2 ⁴	2 ³		2 ²	2 ¹	2 ⁰
KO1	0	0	0	KI1	0	0	0
KO2	0	0	1	KI2	0	0	1
KO3	0	1	0	KI3	0	1	0
KO4	0	1	1	KI4	0	1	1
KO5	1	0	0	KI5	1	0	0
KO6	1	0	1	KI6	1	0	1
KO7	1	1	0	KI7	1	1	0
KO8	1	1	1	KI8	1	1	1

- Data code 2⁶ and the switches have the following relationships. On this model, pin MD0 is used open, so the data code is "0".

Switch	Data Code
	2 ⁶
2-contact switch used, MD0 is used open	0
3-contact switch used, MD0 sends level "1"	1

Level "1" or level "0" can be impressed continuously to MD0 DC-wise or during key read-in only. In this case, if level "1" is impressed during key read-in, remote control output data code 2⁶ will have "1" output. However, if level "1" is impressed DC-wise, power consumption is performed by the Pull Down register.

3-4. Mode Switching Pins and Word Code

Mode Switching Pin Name	MD1	MD2	MD3	MD4	MD5
Word Code	2^7	2^8	2^9	2^{10}	2^{11}

When MDn is at level "1", data code 2^{n+6} becomes data "1".

This model's word code is 10001.

3-5. Transmission Codes

$$(2^7 - 2^{11})$$

- Word Code: 10001
- Data code

(LSB - MSB) 2^0 - 2^6	Command
0 0 0 0 0 0	1
1 0 0 0 0 0	2
0 1 0 0 0 0	3
1 1 0 0 0 0	4
0 0 1 0 0 0	5
1 0 1 0 0 0	6
0 1 1 0 0 0	7
1 1 1 0 0 0	8
0 0 0 1 0 0	9
1 0 0 1 0 0	0
1 1 1 1 0 0	CLEAR
0 0 1 1 1 0	START
0 0 0 1 0 1	▶▶
1 0 0 1 0 1	◀◀
1 1 0 1 0 1	REPEAT CLEAR
0 0 1 1 0 1	REPEAT ALL
1 0 1 1 0 1	REPEAT 1
0 0 0 0 1 1	◀◀
1 0 0 0 1 1	▶▶
0 1 0 0 1 1	▶
1 1 0 0 1 1	◀◀◀
0 0 1 0 1 1	▶▶▶
0 0 0 1 1 1	RESET
1 0 0 1 1 1	

3-6. Key Matrix Output Pins Output Waveforms

1) Initial State and Input Waiting State

"1" is output constantly. In other words, no matter which switch is turned on, the information is transmitted directly to the key input pin.

2) Key Read-in State

From the end of input waiting state, 200 μsec wide pulses are output with 600 μsec time difference to KO1 - KO8, in that order.

The input frame is 4.8 msec (0.6 sec x 8 Pins) and with 1 frame as the unit, is output continuously until an abnormality is detected in key read-in.

KO1 - KO8 output waveforms

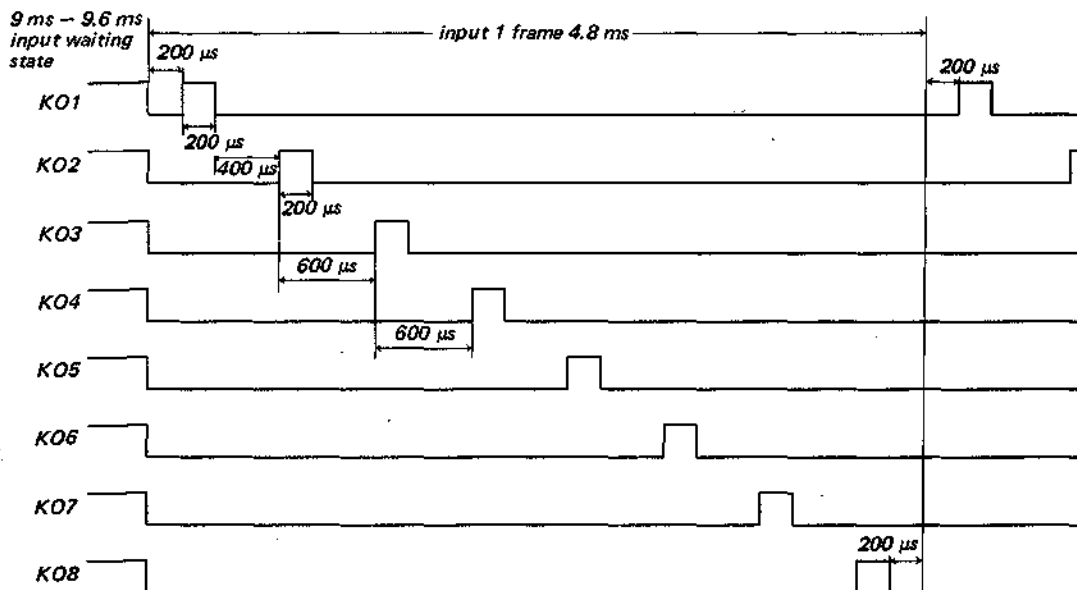

3-7. Output Waveforms

- The order for sending out of each data is:
 - 1) guide pulse
 - 2) data code (from 2^0 to 2^6)
 - 3) word code (from 2^7 to 2^{11})
- Even if the content of each data bit changes, the output frame interval (tf) remains 45 ms.

a) Time when data are all '0'.

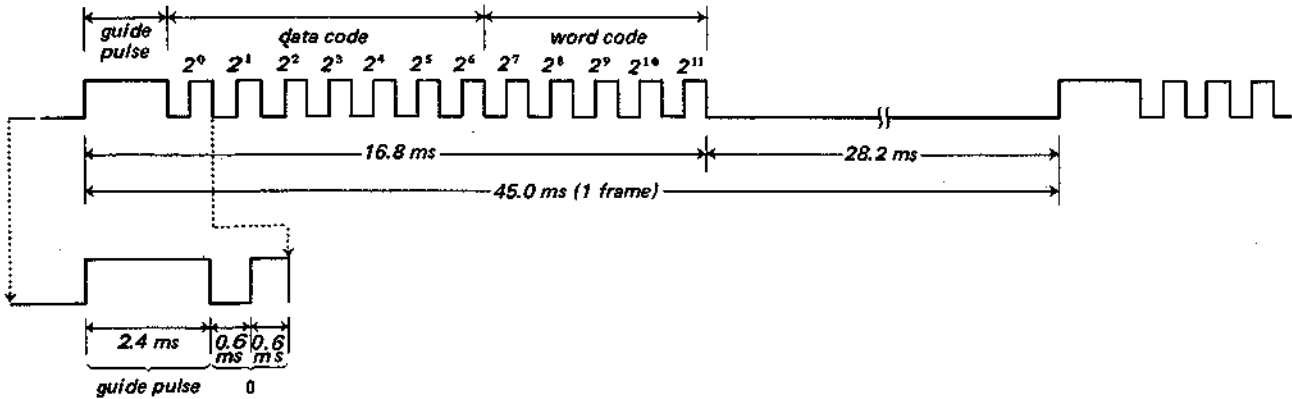

b) Time when data are all '1'.

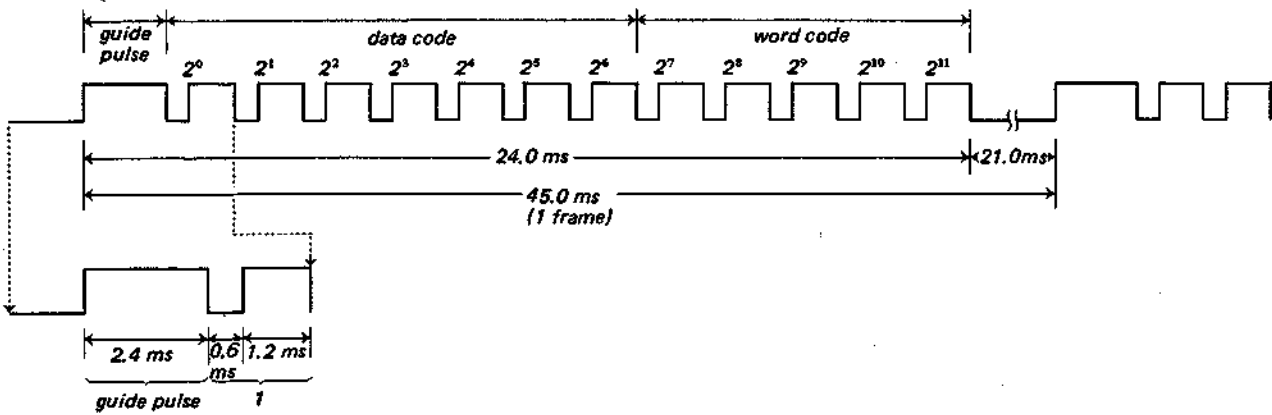

- The output waveform continues to be output while the key input data are continuously input normally. When it is detected that key input data are no longer input (switch off), output stops at the end of the output frame being output at that time.

However, when there are less than 3 output frames at that point, output stops after 3 frames are continuously output.

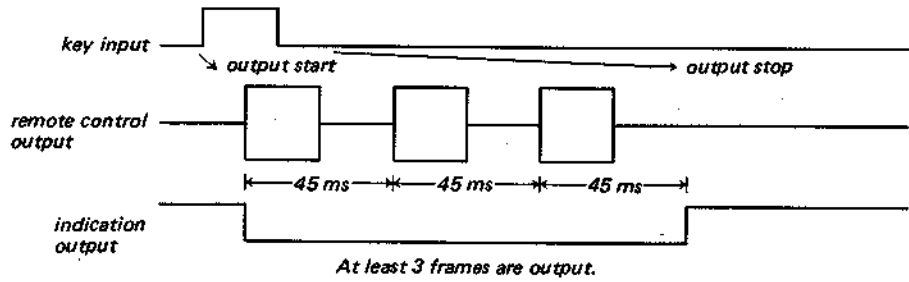
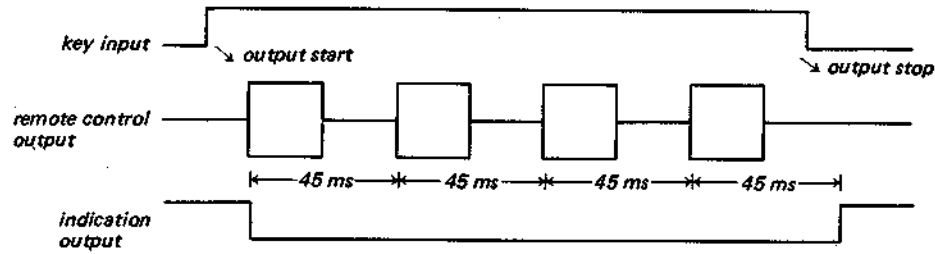

- During remote control output, for the following key input:

If the next switch (b) is pressed before output of data (A) by the first switch (a) on ends, b switch key input is not accepted until A data output ends. After A data ends, there is a 9.0 - 9.6 ms input waiting state (to remove chattering), and B data output begins from the point where the equality of the first two key input frames is confirmed.

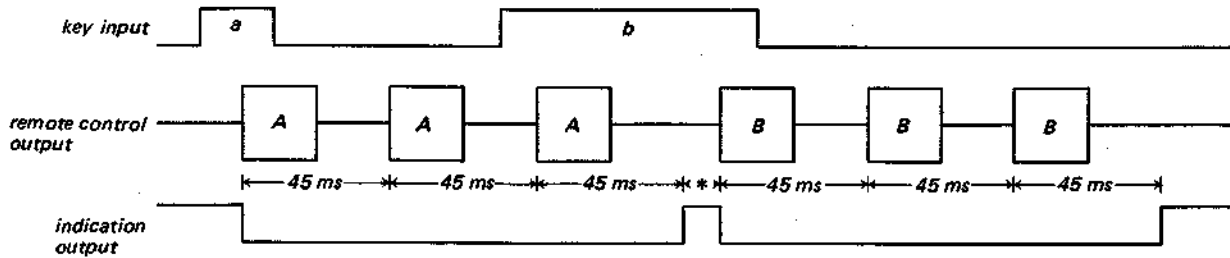

* This time is the 9.0 - 9.6 ms input waiting time and 9.6 ms key input 2 frame time.

3-8. Indication Output

"0" Level is output during the remote control output signal, and level "1" is output when remote control output is stopped. Remote control output signal output indicates the output frame (45 msec) time of the remote control output.

The output timing of the remote control output signal and indication output signal has a time difference of within 1 msec.

RM-101 RM-101

4. MOUNTING DIAGRAM

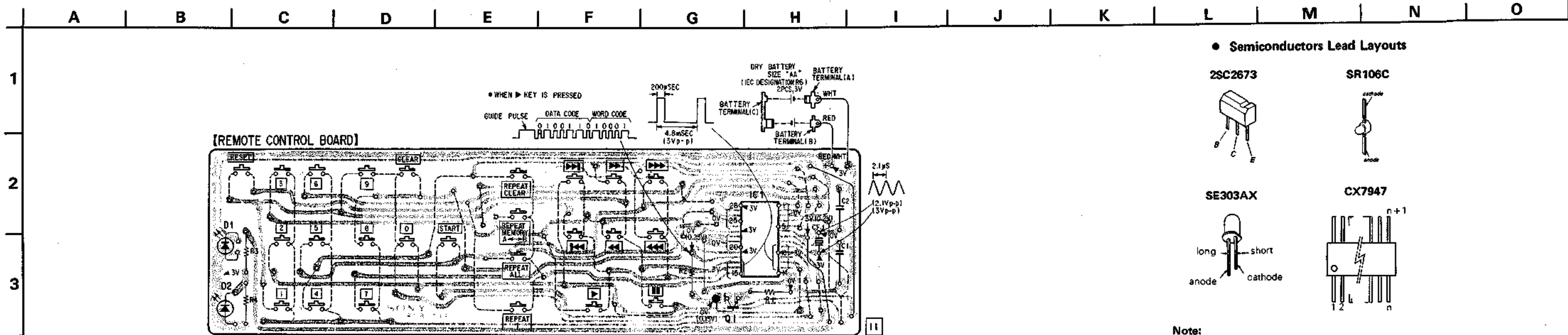

• Semiconductors Lead Layouts

2SC2673

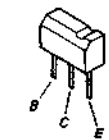

SR106C

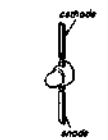

SE303AX

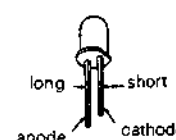

CX7947

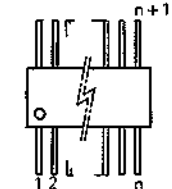

Note:

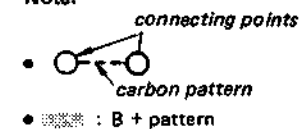

5. SCHEMATIC DIAGRAM

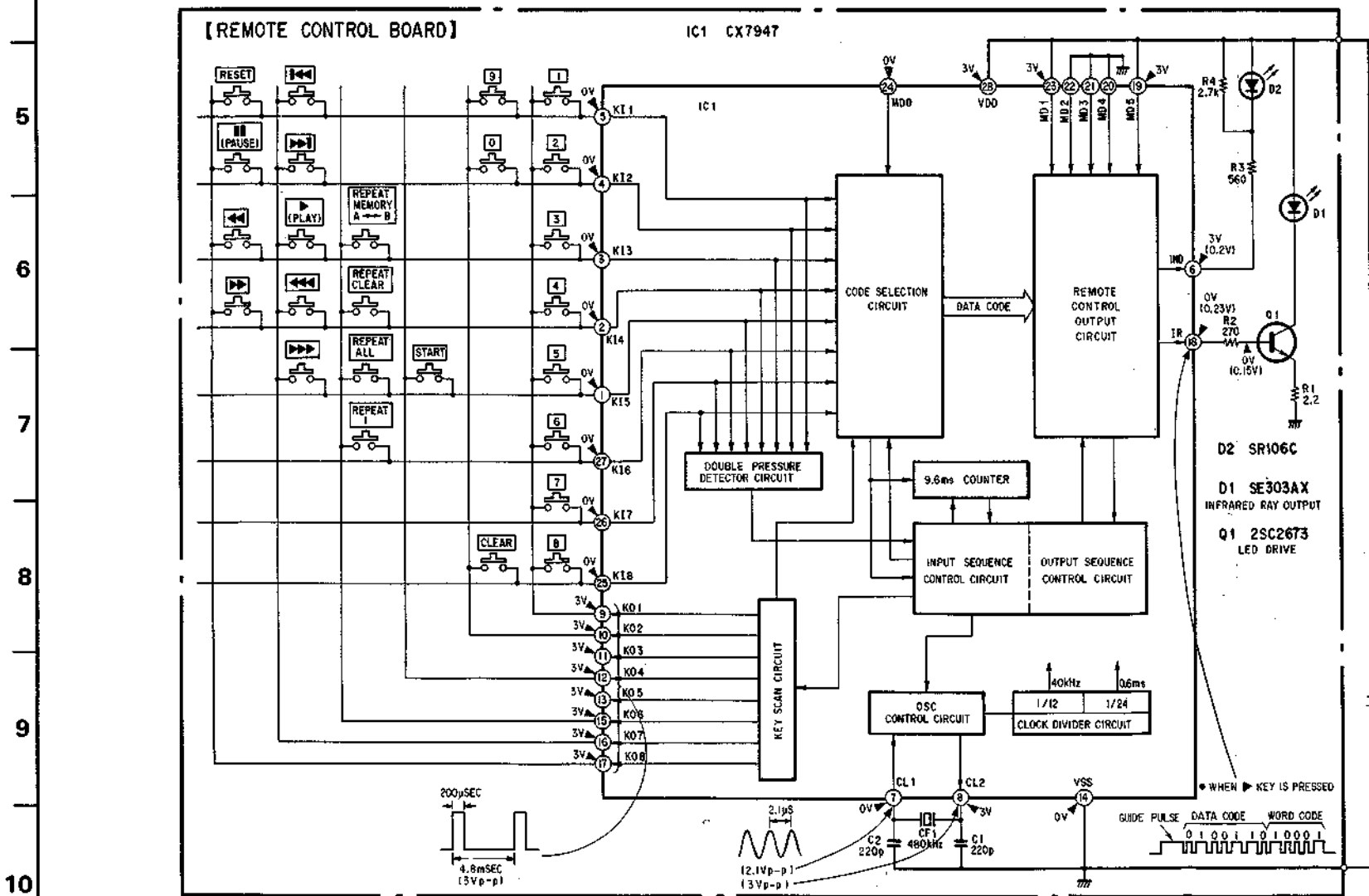

Note:

- All capacitors are in μF unless otherwise noted. pF : μF 50WV or less are not indicated except for electrolytics and tantalums.
- All resistors are in ohms, $\frac{1}{4}\text{W}$ unless otherwise noted. $\text{k}\Omega$: 1000 Ω , $\text{M}\Omega$: 1000 $\text{k}\Omega$
- — : B+ bus.
- Voltage waveforms are measured when function buttons are pressed. (Refer to CIRCUIT DESCRIPTION on page 94).
- Voltage are dc with respect to ground unless otherwise noted.
- Readings are taken with a VOM (50 $\text{k}\Omega/\text{V}$) under the following conditions.
() : Function buttons are not pressed.
() : Function buttons are pressed.
- Voltage variations may be noted due to normal production tolerances.

Note: Voltages are measured with a VOM (50k Ω /V).

6. EXPLODED VIEW AND PARTS LIST

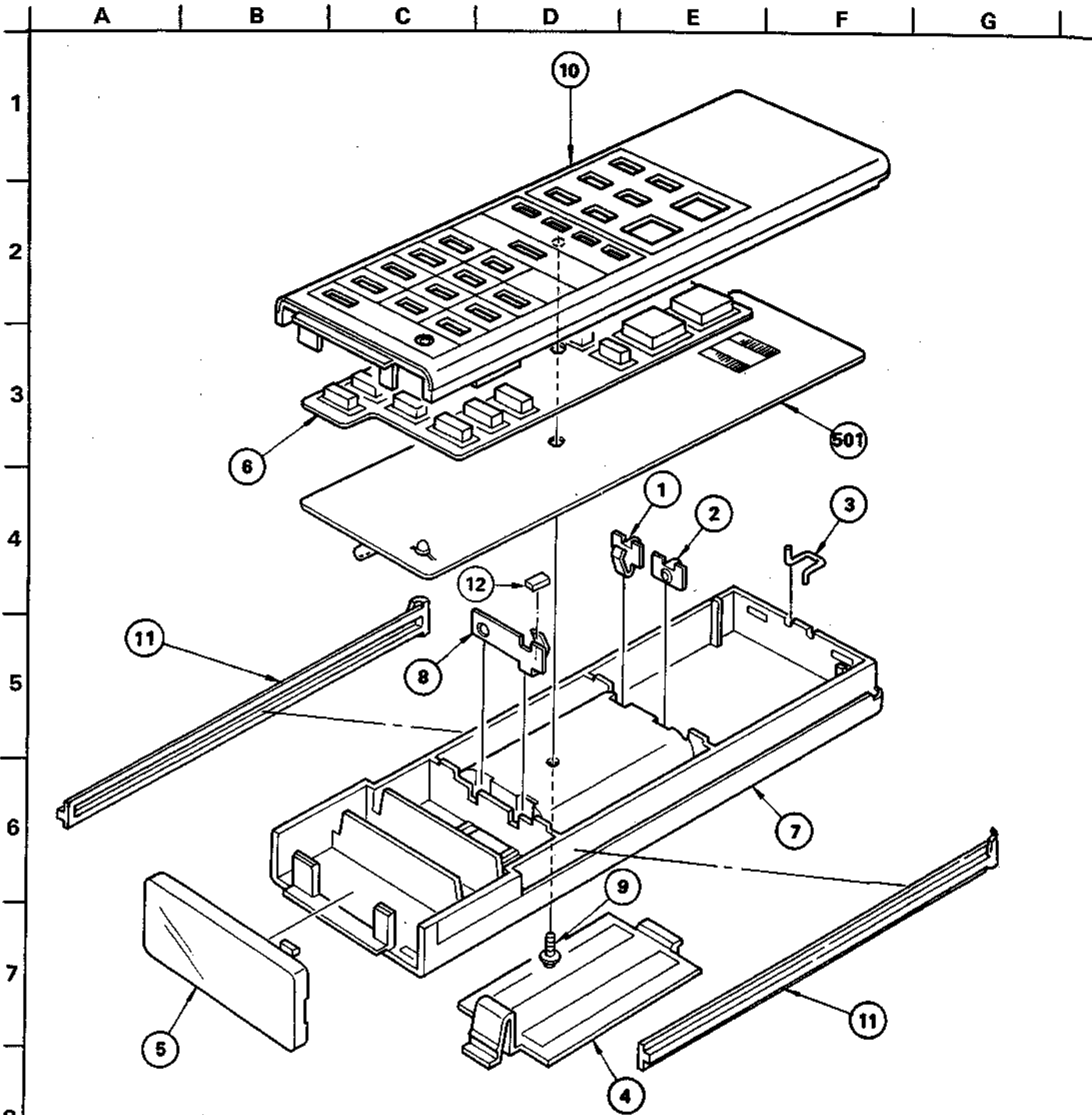

GENERAL SECTION

No.	Part No.	Description
1	2-290-601-00	TERMINAL (A), BATTERY
2	2-290-602-00	TERMINAL (B), BATTERY
3	♦;2-375-001-00	HOOK
4	2-375-003-00	LID, BATTERY CASE
5	2-375-004-00	PLATE, FROSTED
6	2-375-006-00	RUBBER (D), CONTACT
7	2-375-008-00	CASE, LOWER
8	4-350-925-00	TERMINAL (C), BATTERY
9	7-687-204-11	TOTSU PTPWH 2X6 NON-SLIT,TYPE2
10	A-4636-096-A	PANEL ASSY, TOP
11	♦;2-375-013-00	COVER, SIDE
12	9-911-845-XX	CUSHION

NOTE:

Items with no part number and no description are not stocked because they are seldom required for routine service.

Items marked "♦" are not stocked since they are seldom required for routine service. Some delay should be anticipated when ordering these items.

ELECTRICAL PARTS

Ref.No.	Part No.	Description
501	♣;1-608-733-00	PC BOARD, REMOTE CONTROL
C1	1-161-315-00	CERAMIC 220PF 10% 50V
C2	1-161-315-00	CERAMIC 220PM 10% 50V
CF1	1-527-476-41	OSCILLATOR, CERAMIC
D1	8-719-193-03	DIODE SE303AX
D2	8-719-100-06	DIODE SR106C
IC1	8-759-902-22	IC CX-7947
Q1	8-729-967-32	TRANSISTOR 2SC2673-Q
R1	1-246-409-00	CARBON 2.2 5% 1/4W
R2	1-246-459-00	CARBON 270 5% 1/4W
R3	1-246-467-00	CARBON 560 5% 1/4W
R4	1-246-483-00	CARBON 2.7K 5% 1/4W

NOTE:

- Items with no part number and no description are not stocked because they are seldom required for routine service.
- Items marked "♣" are not stocked since they are seldom required for routine service. Some delay should be anticipated when ordering these items.
- Due to standardization, parts with part numbers (Δ-ΔΔΔ-ΔΔΔ-XX or Δ-ΔΔΔΔ-ΔΔΔ-X) may be different from those used in the set.

CAPACITORS:

- MF:μF, PF:μμF.

RESISTORS:

- F : nonflammable

COILS

- MH : mH, UH : μH

SERVICE MANUAL

SUPPLEMENT

Subject : D/A CONVERTER IC (IC301, 401) CHANGE

US Model
Canadian Model
AEP Model
UK Model

No. 1
October, 1983

This supplement updates the service manual to include production changes starting with the serial number inscribed below.
File this supplement with the service manual.

• Applicable Serial No. :

- US Model: 800,301 and later
- Canadian Model: 700,101 and later
- AEP Model: 501,401 and later
- UK Model: 600,101 and later

IC301, 401 CX890 → CX20017

Because of this change,

- Audio board and the circuit around D/A converter IC have been changed.
- There are 2 types of IC301, 401.
- There are 2 types of T201.

Therefore, be careful when replacing IC301, 401, T201. Besides, because of this change, the subject on "Notes on transformer (T201) replacement" on Page 11 of Service Manual should be performed only for the sets that use CX890 for D/A converter IC (former type).

NOTES ON IC, TRANSFORMER REPLACEMENT

Only for the sets that use CX890 for IC301, 401 (D/A converter IC).

- When replacing T201, cut the center lead, as shown in the illustration below. Be careful to the mounting direction of T201.

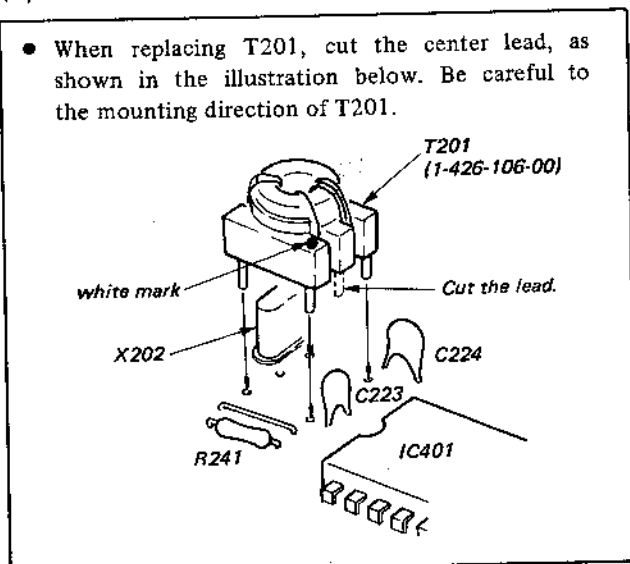

COMPACT DISC PLAYER
SONY®

SERVO AMP SECTION CHANGE

• Applicable Serial No. :

- US Model: Serial No. 800,001 and later
- Canadian Model: Serial No. 700,001 and later
- AEP Model: Serial No. 501,401 and later
- UK Model: Serial No. 600,101 and later

The mounting position of R725, 740 on the servo amp section and patterns of servo amp board have been changed as follows.

: changed portion

• P. 69

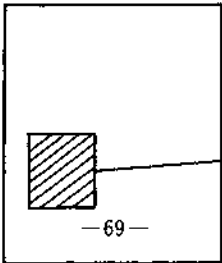

• P. 70

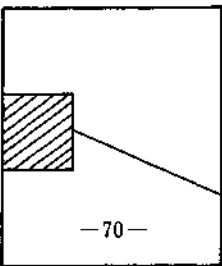

Former type

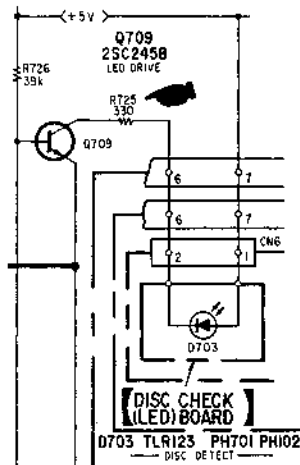

New type

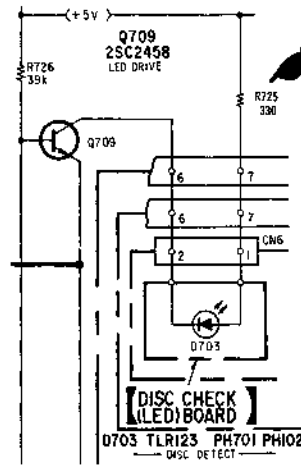

Former type

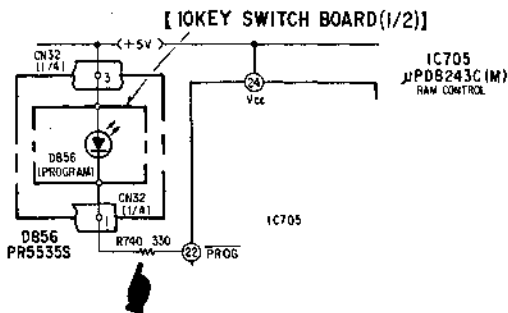

New type

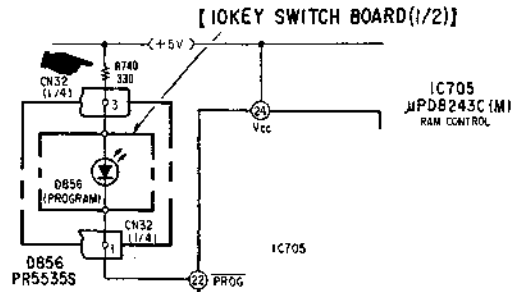

CDP-701ES

● CHANGED PARTS

Ref. No.	Former Parts (Up to Serial No. 205,500)				New Parts (Serial No. 205,501 and later)				Remarks
	Part No.	Description			Part No.	Description			
C223	1-102-516-00	CERAMIC	27pF	5% 50V	1-102-513-00	CERAMIC	18pF	5% 50V	CHANGED
C224	1-102-074-00	CERAMIC	0.001μF	10% 50V	1-102-510-00	CERAMIC	12pF	5% 50V	CHANGED
C240	-----				1-102-510-00	CERAMIC	12pF	5% 50V	ADDED
C303	1-131-450-00	TANTALUM	1μF	20% 50V	1-107-319-00	MICA	1000pF	5% 100V	CHANGED
C307	1-107-309-00	MICA	100pF	5% 500V	1-104-241-00	STYROL	470pF	5% 500V	CHANGED
C357	1-107-327-00	MICA	7pF	500V	1-131-450-00	TANTALUM	1μF	20% 50V	CHANGED
C358	-----				1-131-450-00	TANTALUM	1μF	20% 50V	ADDED
C359	-----				1-107-329-11	MICA	820pF	5% 100V	ADDED
C360	-----				1-107-329-11	MICA	820pF	5% 100V	ADDED
C363	-----				1-107-327-00	MICA	7pF	500V	Ref. No. CHANGED (FORMER TYPE C357)
C403	1-131-450-00	TANTALUM	1μF	20% 50V	1-107-319-00	MICA	1000pF	5% 100V	CHANGED
C407	1-107-309-00	MICA	100pF	5% 500V	1-104-241-00	STYROL	470pF	5% 500V	CHANGED
C457	-----				1-131-450-00	TANTALUM	1μF	20% 50V	ADDED
C458	-----				1-131-450-00	TANTALUM	1μF	20% 50V	ADDED
C459	-----				1-107-329-11	MICA	820pF	5% 100V	ADDED
C460	-----				1-107-329-11	MICA	820pF	5% 100V	ADDED
C463	-----				1-107-327-00	MICA	7pF	500V	Ref. No. CHANGED (FORMER TYPE C457)
C911	1-123-380-00	ELECT	1μF	20% 50V	1-131-347-00	TANTALUM	1μF	10% 35V	CHANGED
C920	-----				1-107-310-00	MICA	220pF	5% 500V	Ref. No. CHANGED (FORMER TYPE C359)
C921	-----				1-107-310-00	MICA	220pF	5% 500V	Ref. No. CHANGED (FORMER TYPE C360)
C922	-----				1-107-310-00	MICA	220pF	5% 500V	Ref. No. CHANGED (FORMER TYPE C459)
C923	-----				1-107-310-00	MICA	220pF	5% 500V	Ref. No. CHANGED (FORMER TYPE C460)
IC155	8-759-993-53	IC	LF353H		8-759-908-85	IC	LF353N		CHANGED
IC301	8-758-900-00	IC	CX890		8-752-001-70	IC	CX20017		CHANGED
IC401	8-758-900-00	IC	CX890		8-752-001-70	IC	CX20017		CHANGED
R241	-----				1-247-807-00	CARBON	100Ω	5% 1/6W	ADDED
R303	1-214-907-00	METAL	56kΩ	1% ½W	1-214-903-00	METAL	39kΩ	1% ½W	CHANGED
R307	1-214-892-00	METAL	15kΩ	1% ½W	1-214-880-00	METAL	4.7kΩ	1% ½W	CHANGED
R310	-----				1-214-880-00	METAL	4.7kΩ	1% ½W	ADDED
R352	-----				1-214-866-00	METAL	1.2kΩ	1% ½W	ADDED
R353	-----				1-214-874-00	METAL	2.7kΩ	1% ½W	ADDED
R356	1-215-234-00	METAL	11kΩ	1% 1W	1-215-813-00	METAL	12kΩ	1% 1W	CHANGED
R357	1-214-855-00	METAL	430Ω	1% ½W	-----				DELETED
R403	1-214-908-00	METAL	62kΩ	1% ½W	1-214-904-00	METAL	43kΩ	1% ½W	CHANGED
R407	1-214-892-00	METAL	15kΩ	1% ½W	1-214-880-00	METAL	4.7kΩ	1% ½W	CHANGED
R410	-----				1-214-880-00	METAL	4.7kΩ	1% ½W	ADDED
R452	-----				1-214-866-00	METAL	1.2kΩ	1% ½W	ADDED
R453	-----				1-214-874-00	METAL	2.7kΩ	1% ½W	ADDED
R456	1-215-234-00	METAL	11kΩ	1% 1W	1-215-813-00	METAL	12kΩ	1% 1W	CHANGED
R457	1-214-855-00	METAL	430Ω	1% ½W	-----				DELETED
R914	1-247-852-00	CARBON	7.5kΩ	5% 1/6W	1-247-851-00	CARBON	6.8kΩ	5% 1/6W	CHANGED
R918	△1-213-036-00	(AEP, UK) ... FUSIBLE	1Ω	5% 1W	-----				DELETED
R919	△1-212-934-00	(AEP, UK) ... FUSIBLE	1Ω	5% ½W	△1-213-036-00	(AEP, UK) ... FUSIBLE	1Ω	5% 1W	CHANGED
R920	-----				△1-213-036-00	(AEP, UK) ... FUSIBLE	1Ω	5% 1W	ADDED
R968	△1-212-946-00	(AEP, UK) ... FUSIBLE	3.3Ω	5% ½W	-----				DELETED
R969	△1-212-946-00	(AEP, UK) ... FUSIBLE	3.3Ω	5% ½W	△1-213-036-00	(AEP, UK) ... FUSIBLE	1Ω	5% 1W	CHANGED
R970	-----				△1-213-036-00	(AEP, UK) ... FUSIBLE	1Ω	5% 1W	ADDED
R984	-----				△1-161-734-00	(AEP, UK) ... CERAMIC	2200pF	20% 400V	ADDED
R1000	-----				1-246-425-00	CARBON	10Ω	5% ¼W	ADDED (Used for spacer between bus bars.)
T201	1-426-106-00	TRANSFORMER, RF			1-426-090-00	TRANSFORMER, RF			CHANGED

Step 1

MOUNTING DIAGRAM - Audio Amp Section -

[AUDIO AMP BOARD] (CONDUCTOR SIDE)

Q - IC	D
352	408,402
351	401 407
IC204	201 403
IC210	
IC212	IC403
IC401	
IC205	
IC202	IC402
	401
	211 404
	212 405
	210 209
IC209, IC211	302 308
IC201	301 306
IC203	
	IC351
	201 307
	202 305
	203
IC303	
IC301	451
IC213	
105	
IC154	451
IC153	IC302
	156
IC155, IC156	956, 906
	154 304
	152, 153
101, 102	151 160 305
	157 161
103, 104	159
	957
	956, 957
	158
	IC951
IC152	IC903 951
	904
IC110	
	902
IC107, IC151	908, 956, 954
106	
IC109	
IC904	
IC106	905 902
	904
	901
IC101~104	901
IC108	906, 907
IC901	
IC105	908
Q - IC	D

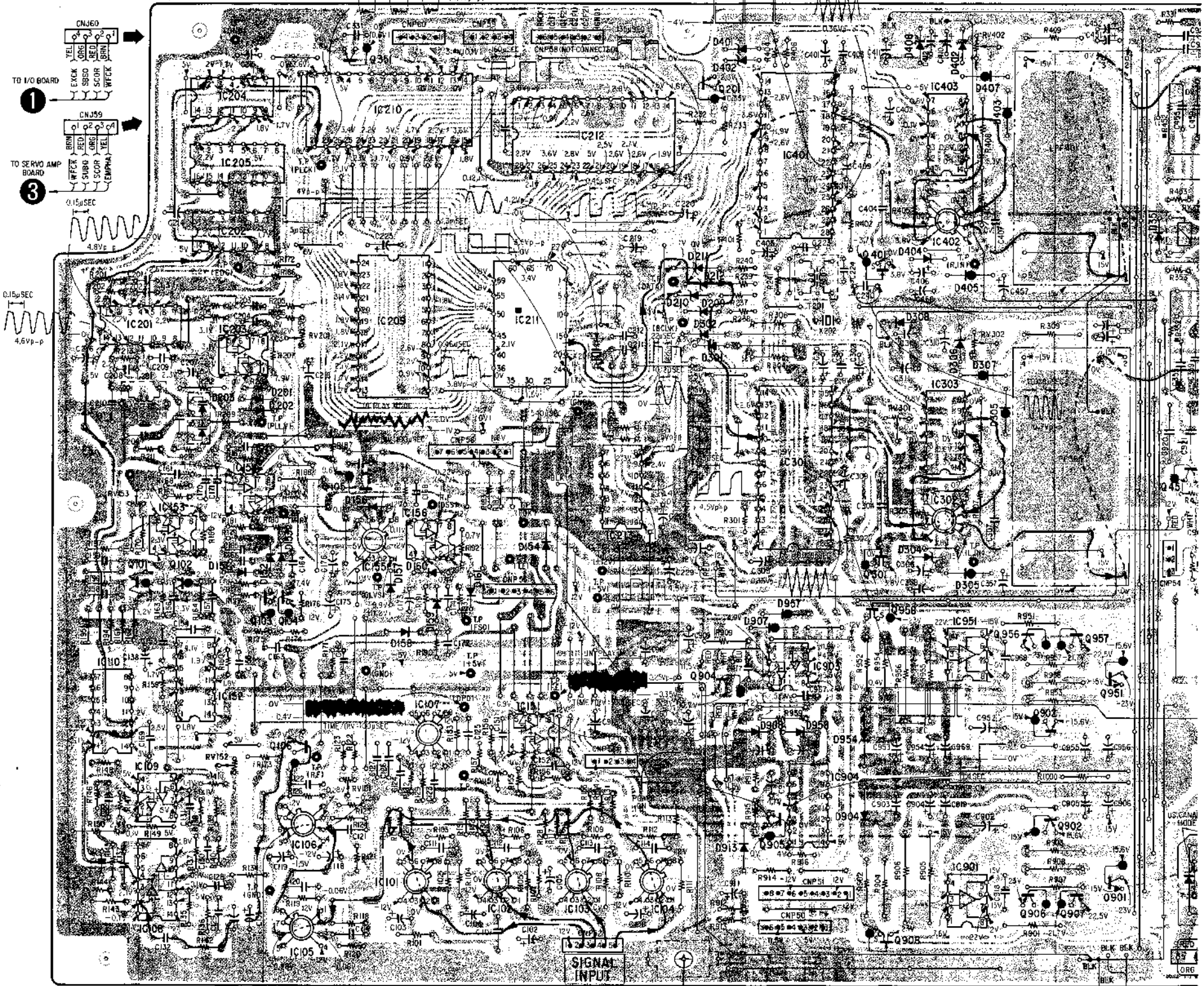

- Note:
- Color code of sleeving over the end of the jacket.
 - WHT (RED) (RED/GRY)
 - : parts extracted from the component side.
 - : parts extracted from the conductor side.
 - ▨ : B+ pattern
 - ▩ : B- pattern
 - : signal path
 - : L-CH signal path
 - : R-CH signal path
 - Readings are taken under no-signal (detuned) conditions with a VOM (50 kΩ/V).
 - no mark : STOP
 - () : play
 - Voltages and waveforms are with respect to ground by using an oscilloscope.

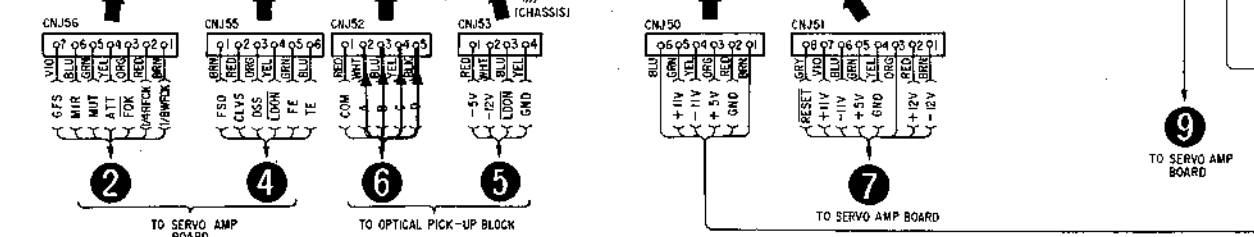

K L M N O P Q R S T U V W X Y Z

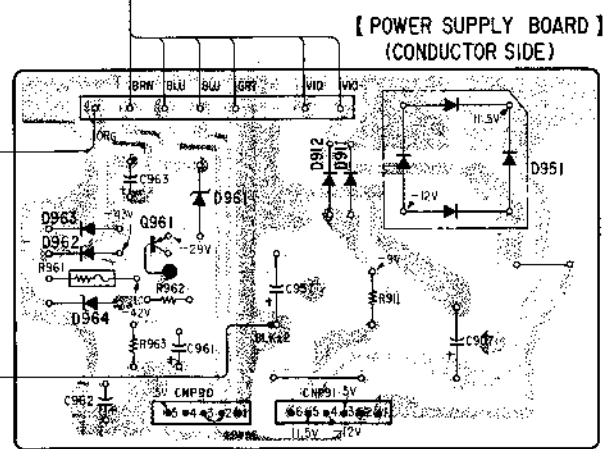
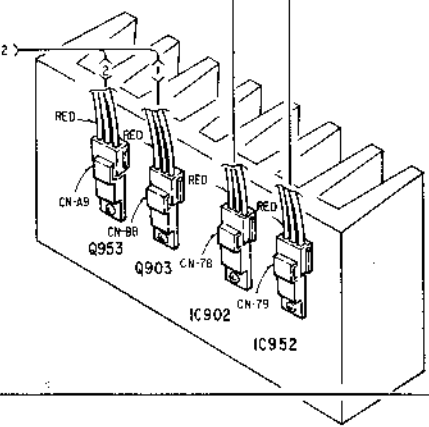
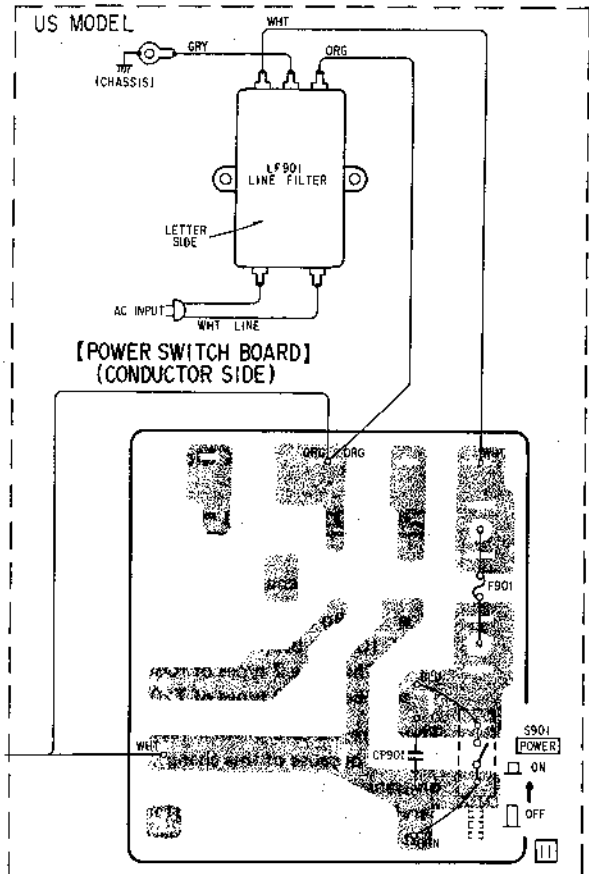
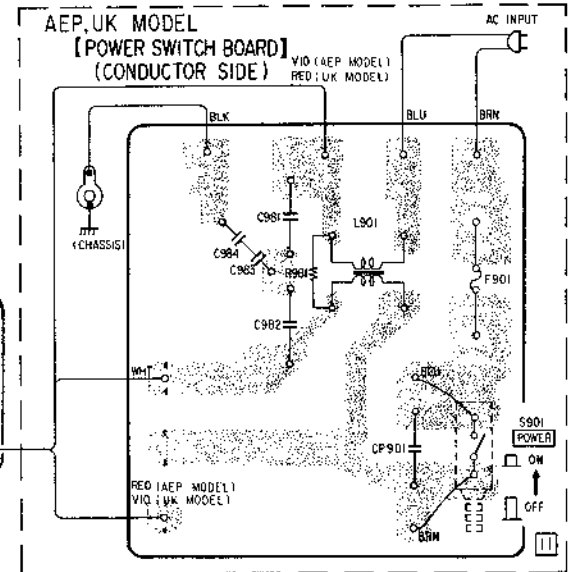
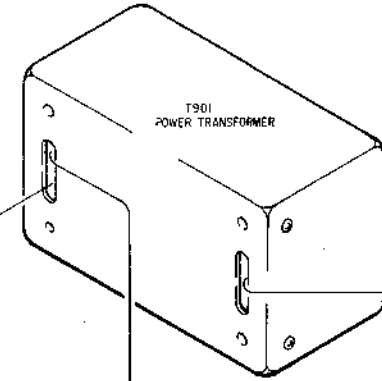
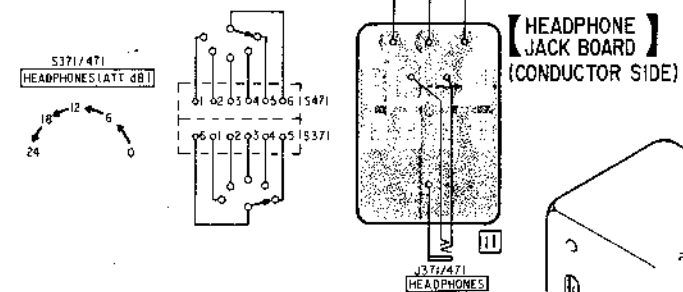
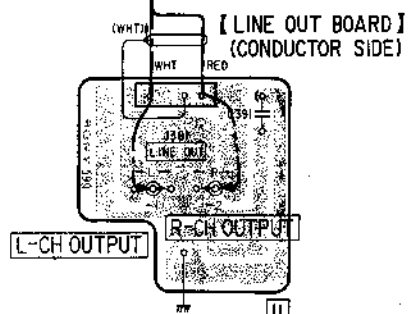
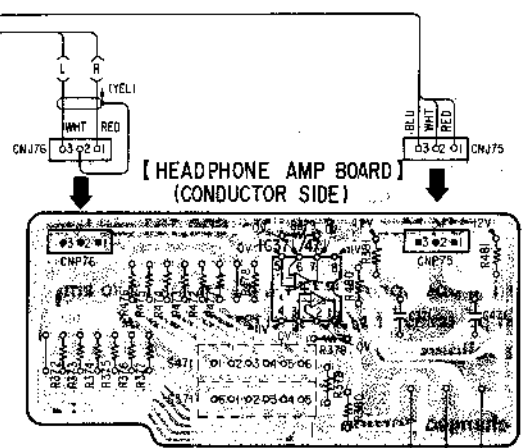
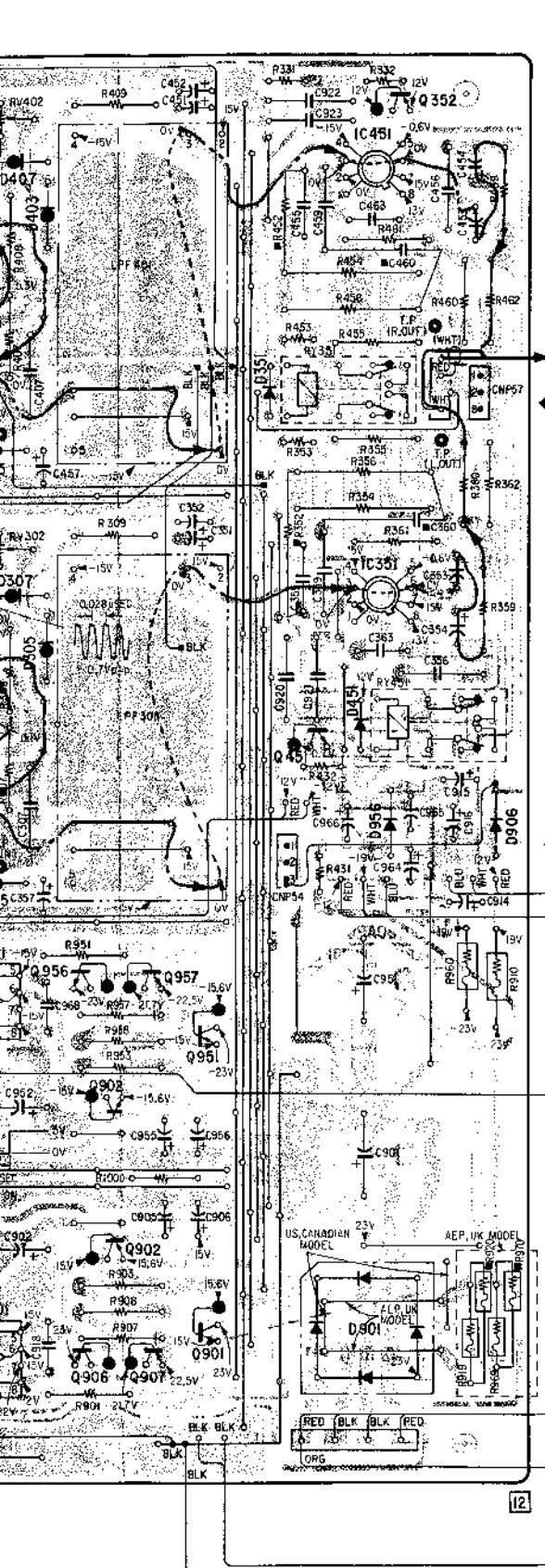

Q	D
	951
	912, 911
	961
963	
962	
961	
964	

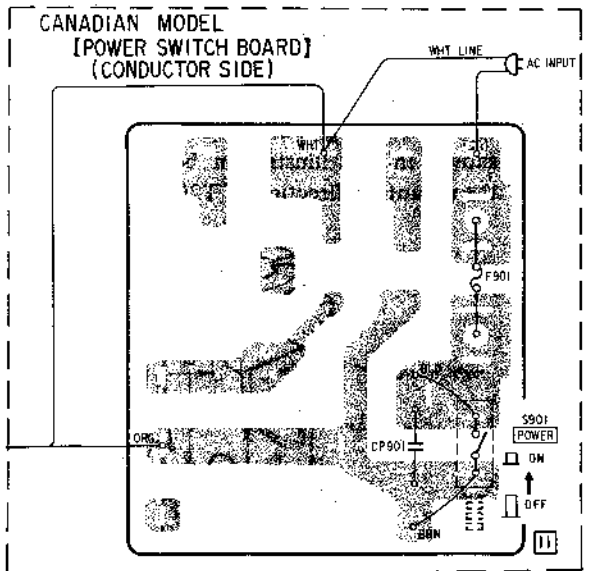

9
TO SERVO AMP BOARD

8
TO DISPLAY IC BOARD

1
2
3
4
5
6
7
8
9
10

Supd

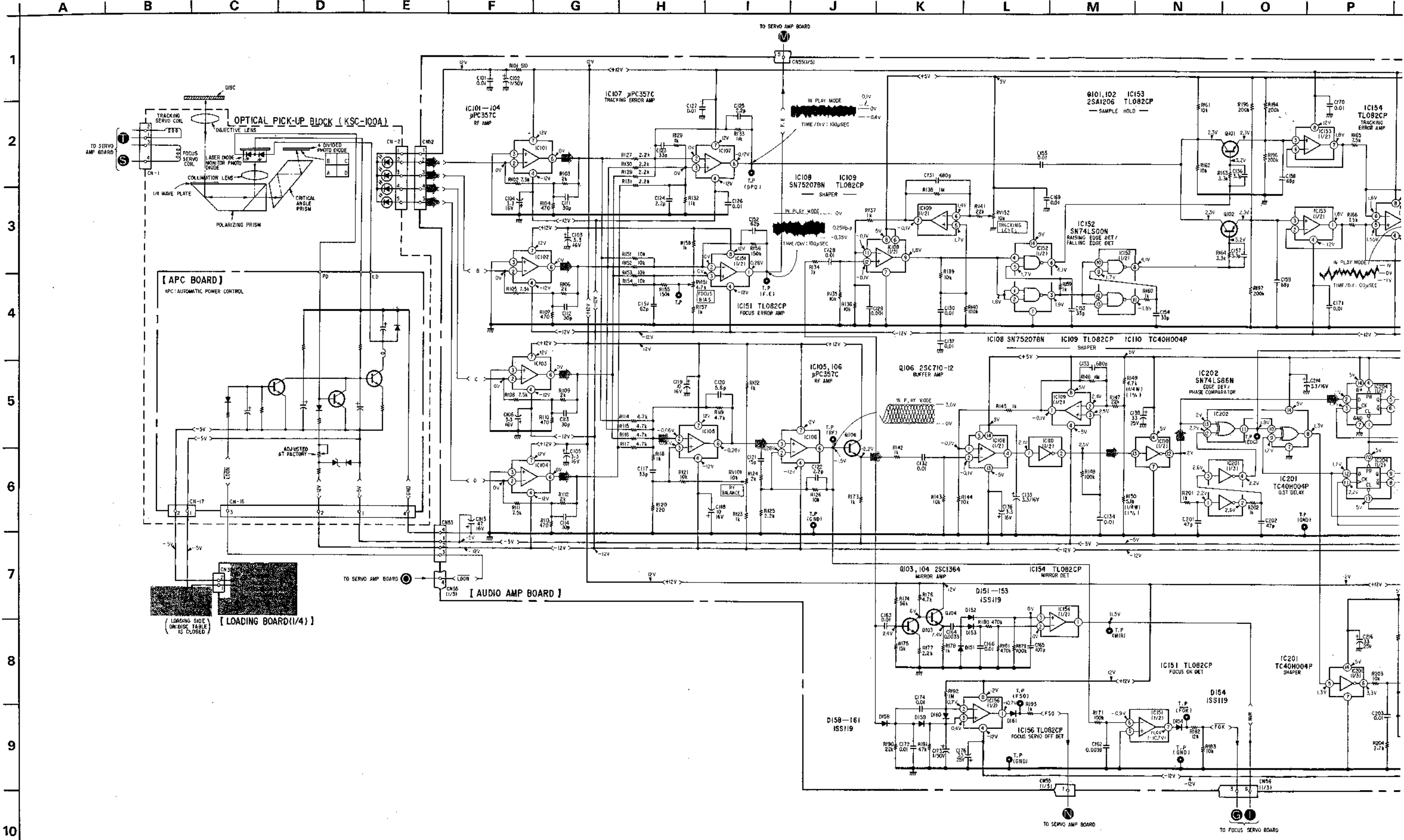

CDP-701ES CDP-701ES

Supd

Supd

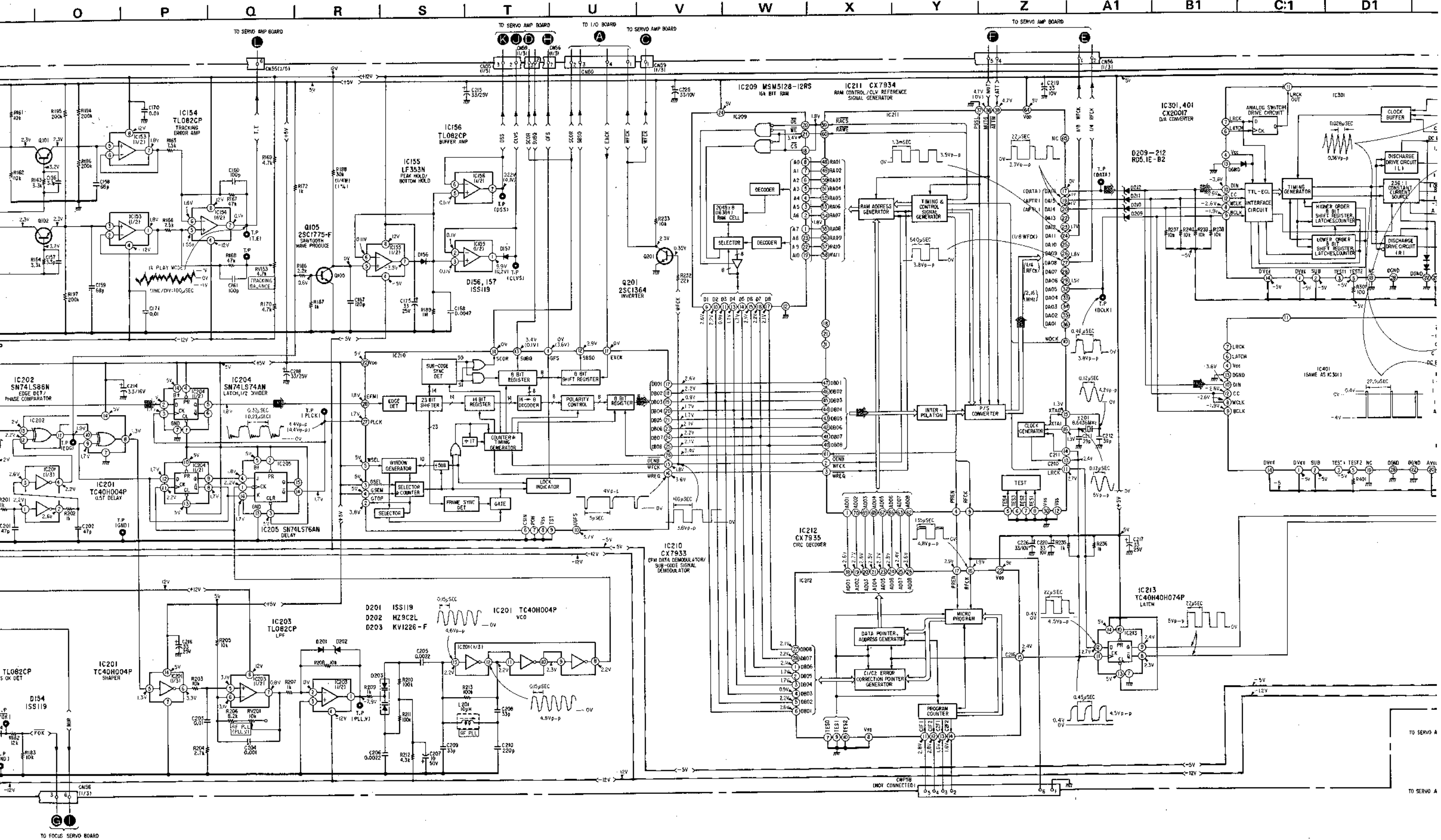

Suppl

CDP-701ES CDP-701ES

A1 B1 C:1 D1 E1 F1 G1 H1 I1 J1 K1 L1 M1 N1 O1 P1 Q1

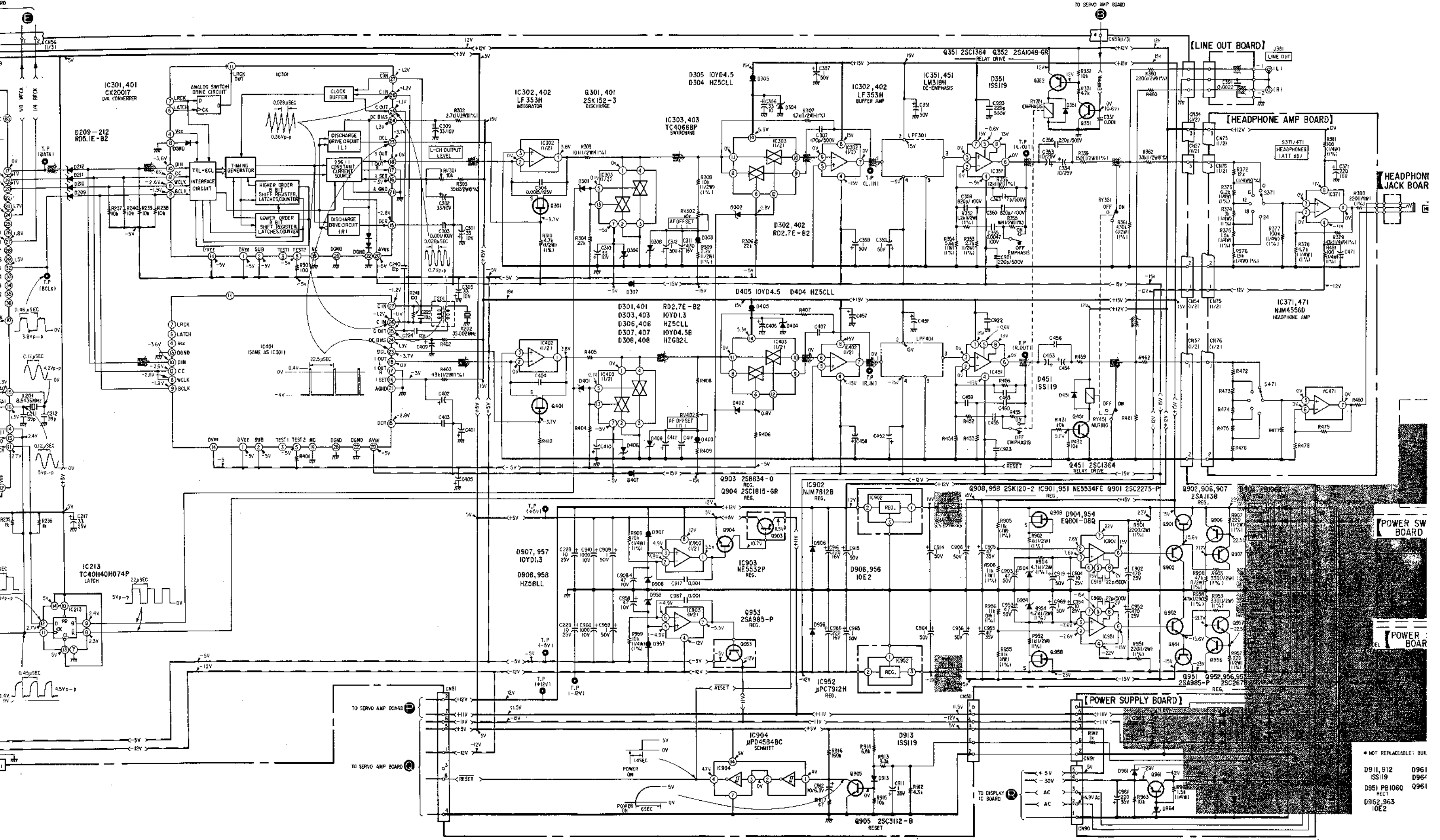

- * NOT REPLACEABLE: BUILT
- D911, 912
 - ISS119
 - D951 PB106Q
 - D962, 963
 - IOE2
 - Q961
 - D962
 - Q961

