

CDP-502ES / 620ES

SERVICE MANUAL

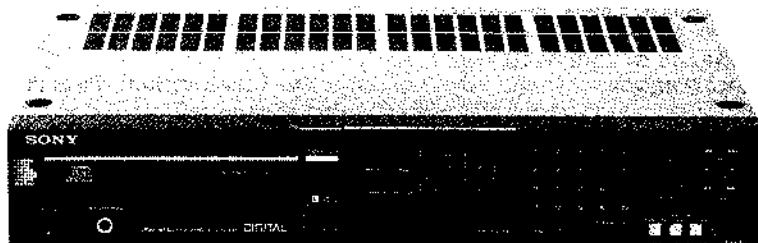

CDP-620ES:
US Model
Canadian Model

CDP-502ES:
AEP Model
UK Model
E Model

SPECIFICATIONS

COMPACT DISC PLAYER

System Compact disc digital audio system
Disc Compact disc
Laser Semiconductor laser ($\lambda = 780 \text{ nm}$)
Laser output Max. 0.6 mW *

*This output is the value measured at a distance of about 1.6 mm from the objective lens surface on the Optical Pick-up Block.

Spindle speed 200 r.p.m. to 500 r.p.m. (CLV)
Scan velocity 1.2 - 1.4 m/sec.
Error correction Sony Super Strategy Cross Interleave
Reed Solomon Code

Number of channels 2
D-A conversion 16-bit linear
Frequency response 2 - 20,000 Hz $\pm 0.5 \text{ dB}$
Harmonic distortion Less than 0.0025% (1 kHz)
Dynamic range More than 96 dB
Channel separation More than 95 dB
Wow and flutter Below measurable limit
Outputs Line outputs
FIXED (phono jacks)
Output level 2 V rms (at MSB)
Load impedance over 10 kilohms
VARIABLE (phono jacks)
Max. output level 2 V rms (at MSB)
Load impedance over 50 kilohms
Headphones (stereo phone jack)
28 mW at 32 ohms

SAFETY-RELATED COMPONENT WARNING!!

COMPONENTS IDENTIFIED BY SHADING AND MARK  ON THE SCHEMATIC DIAGRAMS AND IN THE PARTS LIST ARE CRITICAL TO SAFE OPERATION. REPLACE THESE COMPONENTS WITH SONY PARTS WHOSE PART NUMBERS APPEAR AS SHOWN IN THIS MANUAL OR IN SUPPLEMENTS PUBLISHED BY SONY.

Disc
Track pitch 1.6 μm
Sampling frequency 44.1 kHz
Quantization 16 bit linear quantizing/channel
Modulation system EFM
Transfer rate 2.03 Mbit/sec. (before modulation)

General

Power requirements CDP-502ES
AEP Model: 220 V ac
UK Model: 240 V ac
E Model: 110, 120, 220 or 240 V ac adjustable
50/60 Hz
CDP-620ES
US, Canadian Model: 120 V ac, 60 Hz
Power consumption 16 W
Dimensions Approx. 430 x 80 x 335 mm (w/h/d)
(17 x 3 $\frac{1}{4}$ x 13 $\frac{1}{4}$ inches)
including projecting parts and controls
Weight Approx. 8.5 kg (18 lbs 12 oz), net

ATTENTION AU COMPOSANT AYANT RAPPORT À LA SÉCURITÉ!

LES COMPOSANTS IDENTIFIÉS PAR UNE TRAME ET UNE MARQUE  SUR LES DIAGRAMMES SCHÉMATIQUES ET LA LISTE DES PIÈCES SONT CRITIQUES POUR LA SÉCURITÉ DE FONCTIONNEMENT. NE REMPLACER CES COMPOSANTS QUE PAR DES PIÈCES SONY DONT LES NUMÉROS SONT DONNÉS DANS CE MANUEL OU DANS LES SUPPLÉMENTS PUBLIÉS PAR SONY.

COMPACT DISK PLAYER
SONY®



AUD

PROTECTION OF EYES FROM LASER BEAM DURING SERVICING

This set employs a laser. Therefore, be sure to follow carefully the instructions below when servicing.

WARNING !!

WHEN SERVICING, DO NOT APPROACH THE LASER EXIT WITH THE EYE TOO CLOSELY. IN CASE IT IS NECESSARY TO CONFIRM LASER BEAM EMISSION, BE SURE TO OBSERVE FROM A DISTANCE OF MORE THAN 30 cm FROM THE SURFACE OF THE OBJECTIVE LENS ON THE OPTICAL PICK-UP BLOCK.

1. Laser Diode Properties

- Material: GaAlAs
- Wavelength: 780 nm
- Emission Duration: continuous
- Laser Output: max. 0.6 mW*

* This output is the value measured at a distance of about 1.6 mm from the objective lens surface on the Optical Pick-up Block.

- Classification: Class IIIb

2. During service, do not take the Optical Pick-up Block apart, and do not adjust the APC circuit. If there is a breakdown in the APC circuit (including laser diode), replace the entire Optical Pick-up Block (including APC board).

LASER WARNING LABELS

The labels shown below are affixed.

1. Protective Housing Label

DHHS Non-Interlocked Protective Housing Label
..... (US, Canadian model)



2. Interlock defeatable Label

..... (US, Canadian model)

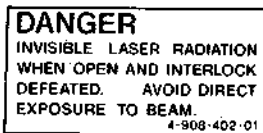

- US, Canadian model

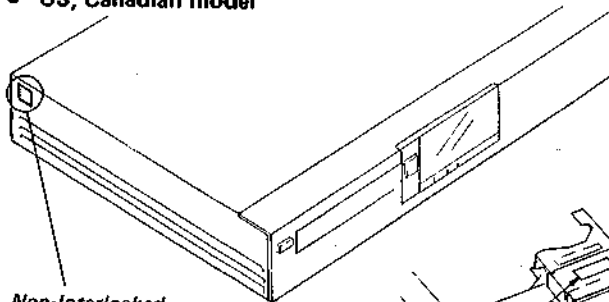

Non-Interlocked Protective Housing Label

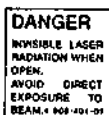

Interlock defeatable Label

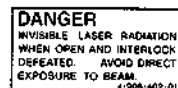

2. Aperture Label (AEP, UK, E model)



- See figure on next page for location of label.

3. Caution Label (AEP, UK, E model)

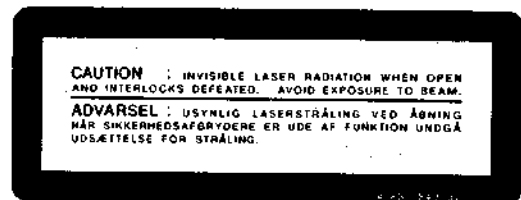

- AEP, UK, E model

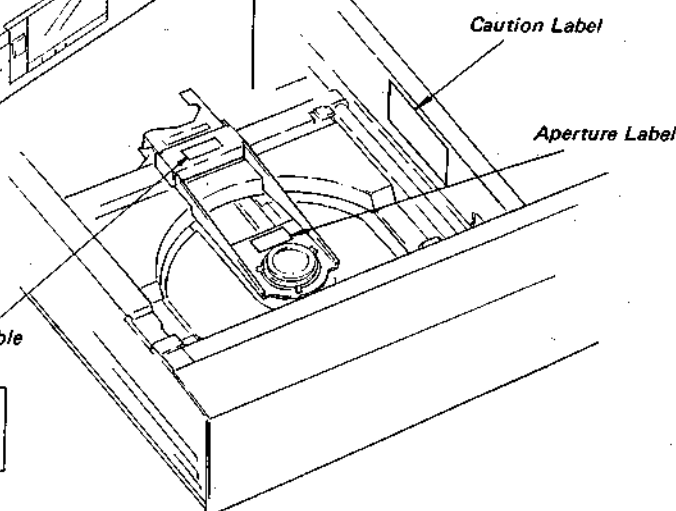

Caution Label

Aperture Label

BESKYTTELSE AF ØJNE MOD LASERSTRÅLING UNDER SERVICE

I dette apparat anvendes laserlys. Derfor skal nedenstående instruktioner nøje følges under service.

Følg iøvrigt instruktionerne i servicemanualen.

ADVARSEL!!

Under service må øjnene ikke komme nær objektiv-linsen på den optiske pick-up enhed. I tilfælde af at det er nødvendigt at kontrollere udsendelsen af laserlys, skal det ske i en afstand af mere end 30 cm fra den optiske pick-up.

1. Data for Laser Diode

- Materiale: GaAlAs
- Bølgelængde: 780 nm
- Udstråling: Kontinuerlig
- Laser Output: max. 0.6 mW*
 - * målt i 1.6 mm afstand fra overfladen af objektiv-linsen på den optiske pick-up enhed.
- Klassifikation: Svarende til klasse IIIb

2. Adskil aldrig den optiske pick-up enhed under service, og juster ikke APC kredsløbet (Automatic Power Control). Hvis APC kredsløbet (incl. laser-dioden) bryder ned, skal hele den optiske pick-up enhed (incl. APC printkortet) udskiftes.

LASER ADVARSEL MÆRKNING (AEP model)

Følgende mærkning findes indvendig i apparatet:

1. Advarsel Mærkning

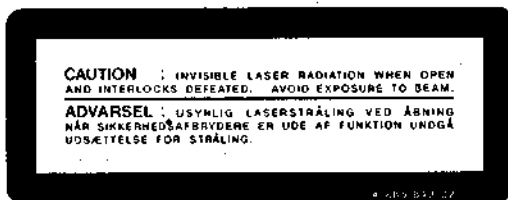

2. Aperture Label



- AEP, UK model

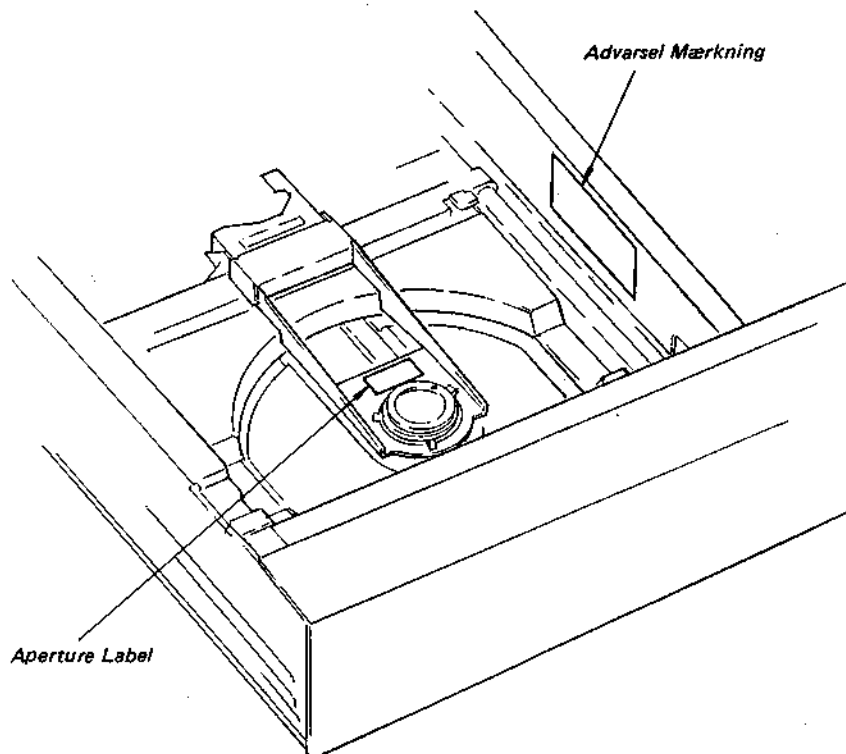

SAFETY CHECK-OUT (US Model)

After correcting the original service problem, perform the following safety check before releasing the set to the customer:

Check the antenna terminals, metal trim, "metallized" knobs, screws, and all other exposed metal parts for AC leakage. Check leakage as described below.

LEAKAGE TEST

The AC leakage from any exposed metal part to earth ground and from all exposed metal parts to any exposed metal part having a return to chassis, must not exceed 0.5 mA (500 microamperes). Leakage current can be measured by any one of three methods.

1. A commercial leakage tester, such as the Simpson 229 or RCA WT-540A. Follow the manufacturers' instructions to use these instruments.
2. A battery-operated AC milliammeter. The Data Precision 245 digital multimeter is suitable for this job.
3. Measuring the voltage drop across a resistor by means of a VOM or battery-operated AC voltmeter. The "limit" indication is 0.75 V, so analog meters must have an accurate low-voltage scale. The Simpson 250 and Sanwa SH-63Trd are examples of a passive VOM that is suitable. Nearly all battery operated digital multimeters that have a 2 V AC range are suitable. (See Fig. A)

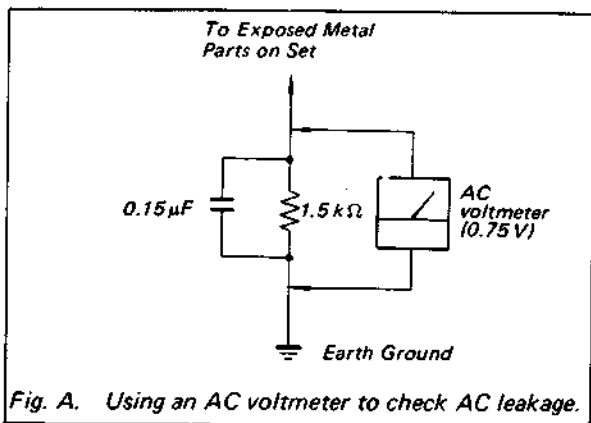

Fig. A. Using an AC voltmeter to check AC leakage.

FEATURES

With the CDP-502ES, flat frequency response (2 – 20,000 Hz), low wow and flutter (lower than the measurable limit), wide dynamic range (more than 96 dB), minimal distortion (0.0025 %) and high channel separation (more than 95 dB) are achieved.

Quick operation

- Feather-touch function keys for direct mode change.
- Linear motor for quick selection search.

Multi-functional

- A variety of playing modes: In the PROGRAM mode the desired selections can be played back in any desired sequence. In the CONTINUE mode playback is continuous from the desired selection to the end of the disc. In the SINGLE mode only one selection is played back.
- The shuffle-play function plays selections back in random order.
- The AMS (Automatic Music Sensor) for quick selection location
- The index function allows you to locate quickly the part you want.
- The repeat function allows you to repeat play continuous in any mode.
- The auto delay function allows you to delay the playback of the first selection 2 seconds.
- An RM-D502 remote commander supplied.
- Large and easy-to-read music calendar display shows the selection numbers on the disc and the time counter shows the elapsed or remaining playing time.

— CAUTION FOR ELECTROSTATIC BREAKDOWN —

NOTES ON HANDLING THE OPTICAL PICK-UP BLOCK (BU-1)

The laser diode in the optical pick-up block may suffer electrostatic breakdown because of the potential difference generated by the charged electrostatic load, etc. on clothing and the human body.

The printed matter below is included in the repair parts. During repair, use the procedure in the printed matter.

The following method is an example for reference purposes:

1. Place a conductive sheet on the workbench. (The black sheet used as repair parts wrapping).
2. Place the set on the conductive sheet so that the chassis touches the sheet. (This makes it the same potential as the conductive sheet).
3. Place your hands on the conductive sheet. (This makes them the same potential as the sheet).
4. Remove the optical pick-up block.
5. Perform work on top of the conductive sheet. Be careful that clothing does not touch the optical pick-up block.

Printed Matter Included in the Repair Parts

When opening or repairing a BU-1, the procedure for grounding as follows is required to prevent damage caused by static electricity.

1. Grounding for the human body.
Be sure to put on a wrist-strap for grounding (with impedance lower than $10^8 \Omega$) whose other end is grounded. The strap works to drain away the static electricity built-up on the human body.
2. Grounding for the work table.
Be sure to lay on the table a conductive sheet (with impedance lower than $10^9 \Omega$) such as sheet of copper which is grounded.
3. As static electricity built-up on clothes is not drained away, be careful not to let your clothes touch the BU-1.

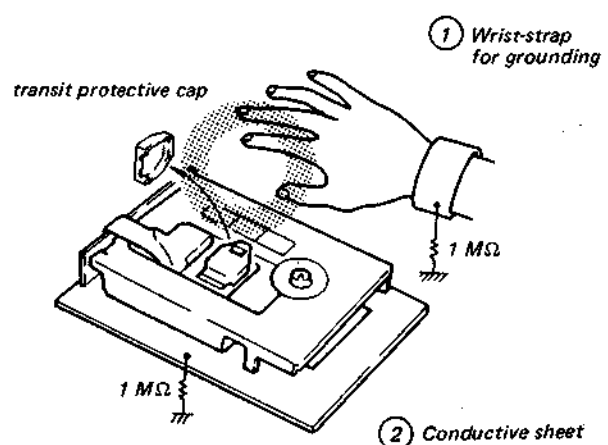
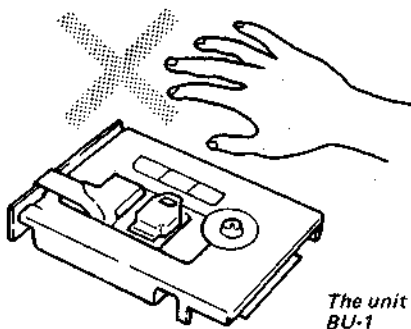

NOTE ON REPAIR

- Are reset signals applied to each IC?
During power ON, a "L" signal is made momentarily at R999 and C995 and applied to the RESET pin of each IC. During power OFF, a "L" signal is made by Q991.
- Are clock signals applied to each IC?
The microcomputer clocks except for remote control are made at IC352 (67.7376 MHz) and then divided into ④ (16.9344 MHz) and output from pin ③.
The clock signals from pin 3 are wave shaped at IC351 and applied to IC603 pin ①. Here they are further divided into two and 8.4672 MHz clocks are applied to IC601. The other microcomputers use the 4.2336 MHz signal (divided at IC603 and output from pin ②).
- Are the optical block and servo operating?
If power is turned on when a disc is not inserted, the laser goes up and down three times. Correct optical block and servo system operation can be checked by confirming by eye that the laser is lit up at this time.

NOTES ON LASER DIODE EMISSION CHECK

The laser beam on this model is concentrated so as to be focused on the disc reflective surface by the objective lens in the optical pick-up block. Therefore, when checking the laser diode emission, observe, from more than 30 cm away from the objective lens.

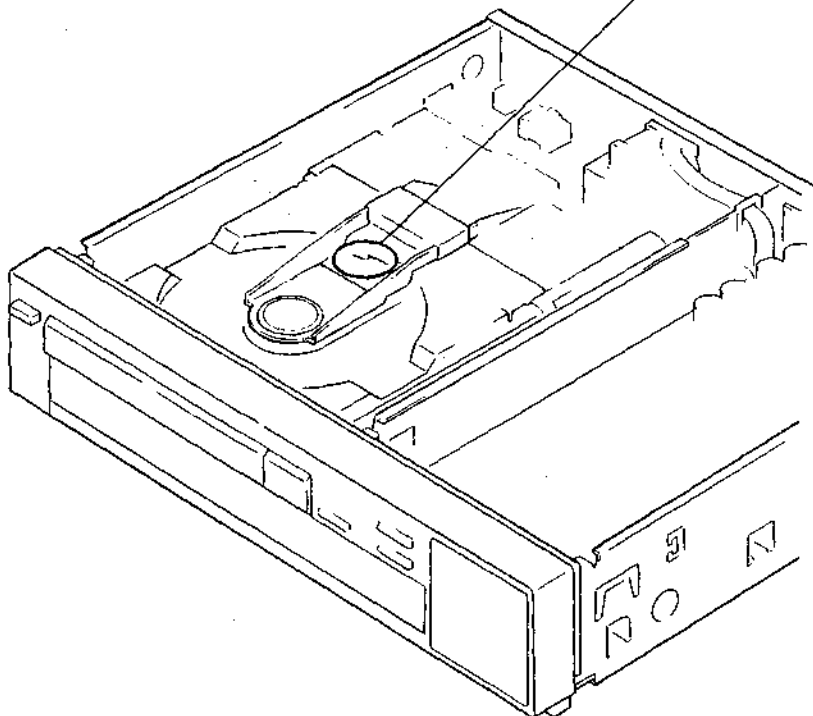
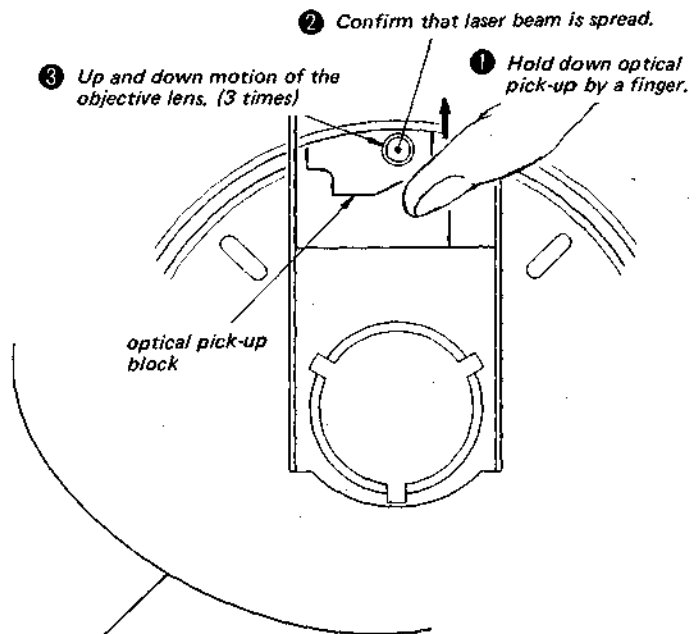

LOCATION AND FUNCTION OF CONTROLS

Front panel

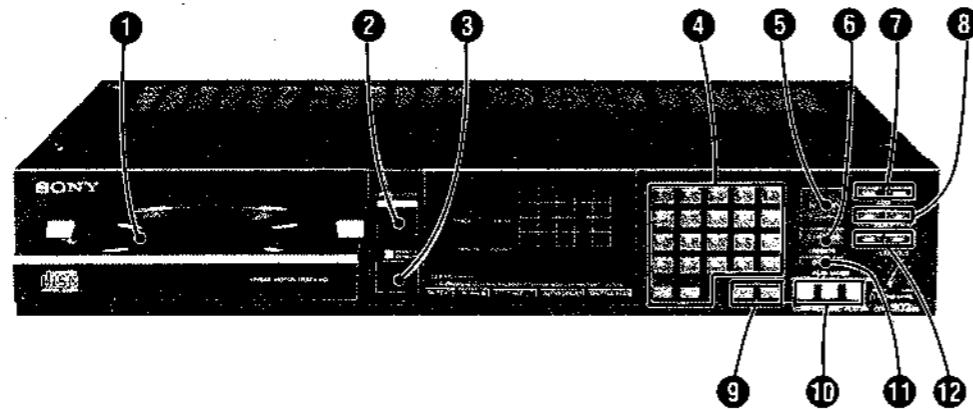

Photo: CDP-502ES

1 Disc compartment

The disc compartment opens when the OPEN/CLOSE key **2** is pressed. The disc compartment can be closed by pressing the front of it lightly, by pressing the OPEN/CLOSE key again or by pressing the ► PLAY key **6**.

2 OPEN/CLOSE key

The disc compartment opens when this key is pressed, and closes when it is pressed again.

3 REMOTE SENSOR and indicator

The signal transmitted by the supplied RM-D502 remote commander is received here. The indicator blinks to indicate that a function key on the remote commander has been pressed.

4 Direct selection keys

The keys numbered **1** - **20**, **+10** and **0** are used to select the desired selection directly by number. Except during the PROGRAM mode (page 15), the selection will begin to play when the numbered key is pressed.

5 ► PLAY key

Press to start disc play. The ► indicator will be lit up during play.

6 || PAUSE key

Press to pause during play. The || indicator will light up. To release the pause mode, press this key again. The || indicator will go off and play will resume.

7 AMS (Automatic Music Sensor) keys

The desired selection can be located by pressing one of these keys during play or during pause.

◀◀: Press once to go back to the beginning of the selection being played. To go back to the previous selection, press two times, and so on.

▶▶: Press once to skip ahead to the beginning of the next selection. Press twice to skip to the following selection, and so on.

8 INDEX keys

Press one of these keys to search for a particular index number (signals prerecorded on the disc, indicating divisions within a selection), to start play from the desired point within a selection. The index numbers are displayed in the display window.

←: Press once to return to the previous index number.

→: Press once to skip to the next index number.

If the key is pressed during playback of a disc on which no index numbers have been recorded, play will start from the beginning of the current selection.

9 CHECK key, CLEAR key

CHECK: This key is for checking the order of the programmed selections.

CLEAR: In order to clear the programmed selections one by one, first display the selection number with the CHECK key, then press this key. Also, press this key to clear **+10** if it is pressed by mistake.

10 PLAY MODE keys

CONTINUE: Press this key to play continuously from the first (or desired) to last selection, in order from the lowest number.

SINGLE: Press to play one selection only.

PROGRAM: Press to program the desired selections in the desired order continuously.

11 STOP (RESET) key

When this key is pressed during play, play will stop and the player will stand by, waiting for your instructions. All selection numbers are displayed in the display window and the TRACK and the INDEX indicators show **0**.

12 Manual search keys

These keys are used to search for a particular point. You can monitor the sound while going in fast forward or fast reverse during search.

◀◀: Keep pressed to go backwards at high speed.

▶▶: Keep pressed to go forward at high speed.

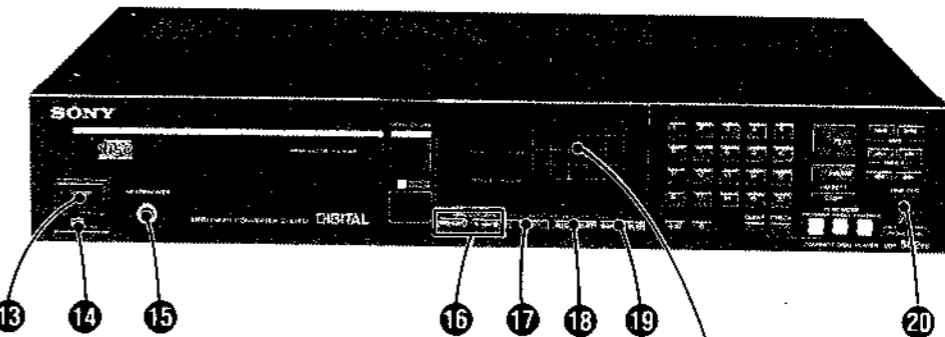

Photo: CDP-502ES

13 POWER switch**14 TIMER switch**

Using an optional timer, the player can be set to start playing automatically at a particular time.

15 HEADPHONES jack (stereo phone jack)

Accepts any stereo headphones equipped with a stereo phone plug.

16 REPEAT key

Press to repeat play. There are five types of repeat play: one selection, all selections, A → B, program and shuffle repeat.

17 TIME (elapsed or remaining time) key

When this key is pressed during play, the time remaining for this selection or the time remaining on the disc is displayed.

18 AUTO DELAY key

When this key is pressed, two seconds of blank space are inserted before play of the first selection begins. This function is cancelled by pressing the key again.

19 SHUFFLE PLAY key

Selections are shuffled and played in a random order when this key is pressed. When all of the selections on the disc have been played once, the shuffle play is cancelled.

Display window

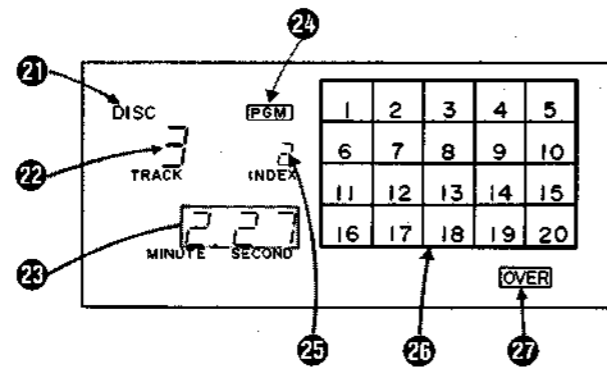

21 LINE OUT/PHONE LEVEL control

This control adjusts the output levels for both the LINE OUT VARIABLE jacks 28 on the rear panel and the HEADPHONES jack 16 on the front panel. Output level increases when it is turned to MAX. This control also turns automatically when operated using the supplied remote commander RM-D502.

22 DISC Indicator

This indicator lights up when the disc compartment is moving, when the disc compartment has closed with a disc in place and during disc playing. You can tell whether a disc is inserted or not even when the disc compartment is closed by checking this indicator.

23 TRACK indicator

When the disc is inserted using the OPEN/CLOSE key 2 or by pressing on the front of the disc compartment 1, the number of selections on the disc is displayed for several seconds. When play begins, the number of the selection being played is displayed. When the ►► key 7 is pressed continuously and you go past the end of the last selection, 77 is displayed. If the ◀◀ key 8 is kept pressed and you go past the beginning of the first selection, LL is displayed.

24 Time counter

When the disc is inserted and the disc compartment closed, the total time of all the selections on the disc is displayed for several seconds. (When the ►► PLAY key 5 is used, this display does not appear.) When play begins, the elapsed time the selection has been playing is displayed. When the TIME key 17 is pressed, the time remaining until the selection ends is displayed after a minus "-" symbol. When this key is pressed again, the play time remaining is displayed after a minus symbol. The display varies depending on the setting of the PLAY MODE key 10 and SHUFFLE PLAY key 19.

25 PGM indicator

This indicator lights up when the PLAY MODE PROGRAM key 10 is pressed in stop mode, then goes out after the disc has begun to play. The indicator also lights up when the programmed selections are being checked even during play.

26 INDEX indicator

This displays the index numbers of the selection being played. After programming but before play, or when checking the programmed selections, the INDEX indicator displays the order the selection currently displayed on the TRACK indicator 22 was programmed. (At this time the red PGM indicator 25 lights up.)

27 Music calendar display window

When a disc is inserted and the player is on stand-by, the number of selections on the disc is displayed. For a disc with 21 or more selections, 1 - 20 light up, as well as the OVER indicator 27. The display changes according to the mode and which function keys are pressed.

28 OVER indicator

This indicator lights up when a disc with more than 21 selections is inserted.

Rear panel

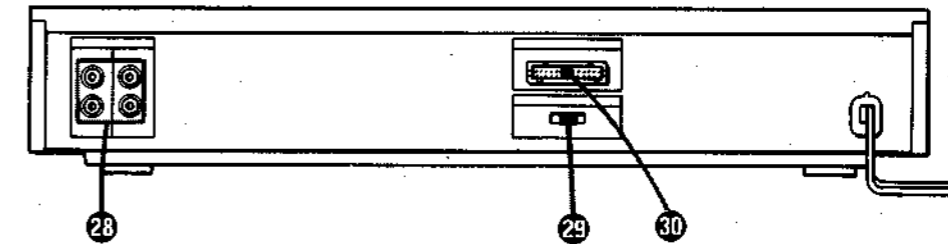

28 LINE OUT jacks

This unit is equipped with two pairs of LINE OUT jacks. The FIXED jacks have a constant output level and the VARIABLE jacks output level can be changed with the LINE OUT control 21. The VARIABLE jacks are convenient to use for matching the playback sound levels of a tuner or other audio equipment and the CD player without having to adjust the volume control of the amplifier. The VARIABLE jacks output level can be also adjusted with supplied remote commander.

29 PLAY MODE initializing switch

This switch performs the same function as the PLAY MODE keys 10 on the front panel. The setting of this switch—CONTINUE, SINGLE or PROGRAM—determines the mode when power is turned on, so set this switch to the mode most often used. After the power is turned on, change the mode with the PLAY MODE keys 10, as this switch does not work once the power is turned on.

30 ACCESSORY CONNECTOR

This connector can be used to connect an optional equipment which will be available in the future.

SECTION 1 OUTLINE

CIRCUIT DESCRIPTION

1-1. OUTLINE

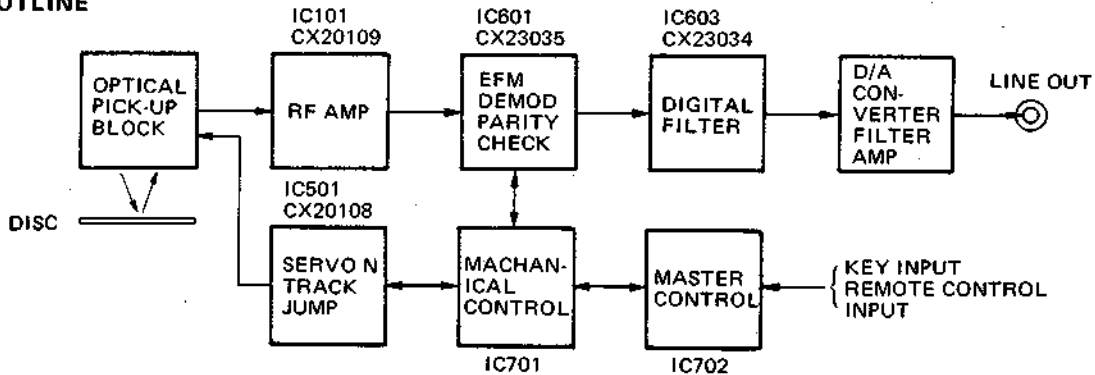

Above block diagram shows configuration of this set. Master control IC (IC702) serves as the center of all operation. Master control IC (IC702) assumes interface between man and machine like key input and remote control input. Mechanical control IC (IC701) assumes interface between master control IC (IC702) and machine.

For example, if PLAY button is pressed from key input, master control (IC702) gives mechanical control IC (IC701) a command to make PLAY mode. When this command is given, mechanical control IC (IC701) works in routine operation to make PLAY mode. It gives every kind of commands for IC501, 601 and they are in PLAY mode.

Through IC501 and IC601 use common data bus, they distinguish a command for IC501 or IC601 by a higher rank 4 bit value of each command from mechanical control IC (IC701).

Command for IC501: higher rank 4 bit 0000-0011 (0-3 with hexadecimal number system) are used.

Command for IC601: higher rank 4 bit 1010-1110 (A-E with hexadecimal number system) are used.

IC501 controls servo (focus, tracking, sled) mainly. IC601 checks EFM demodulation and CRC.

The illustration below shows flow chart of simple operation after power is ON.

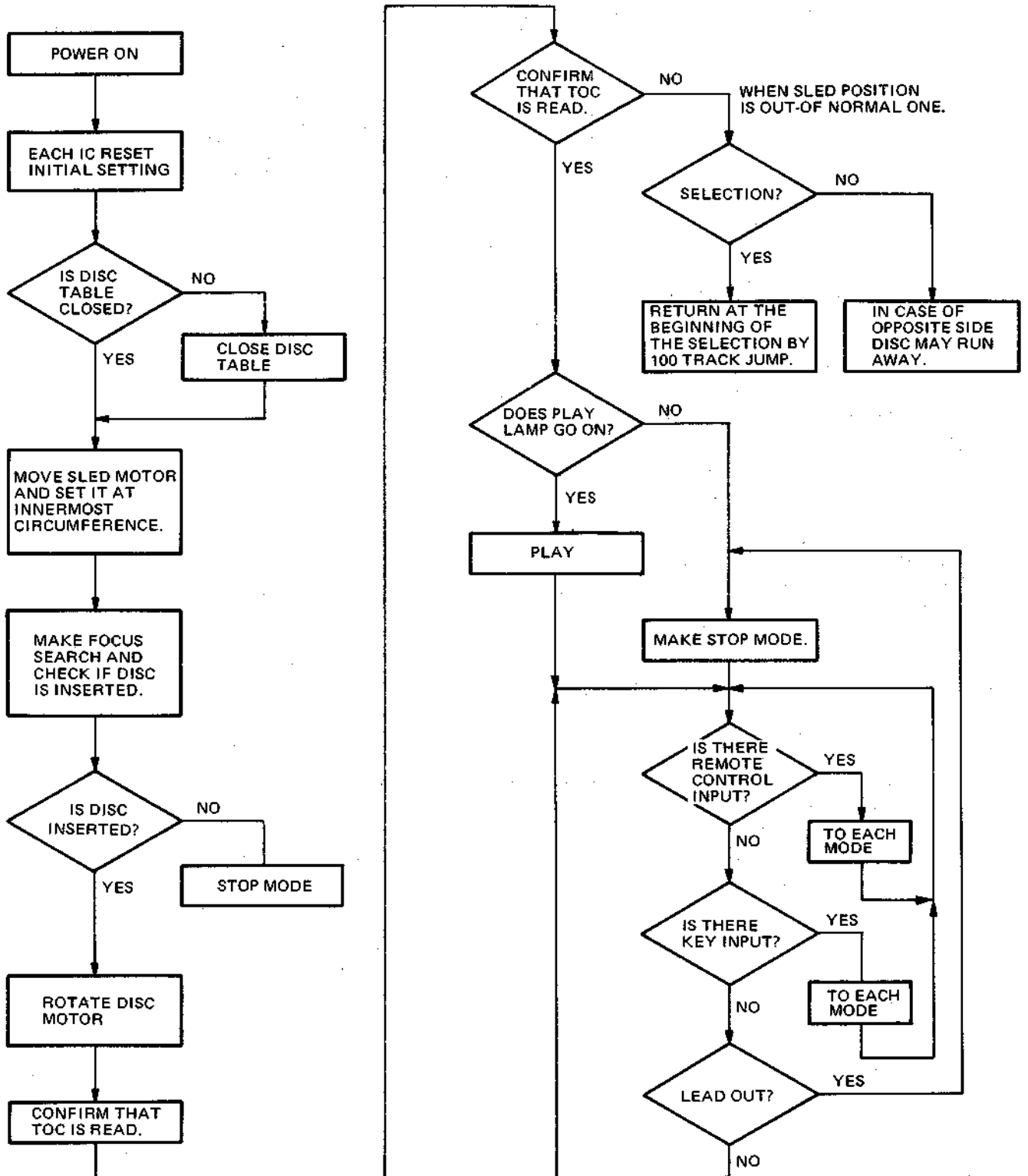

1-2. SIGNAL FLOW

The compact disc player applies a laser beam to the pits on the compact disc, which represent recorded music information, and extracts the changes in the reflected light and converts them into analog signals.

The following is an explanation of the signal flow on this model.

The changes in laser light reflection are extracted as current changes by the pick-up section photodiode. (The current flow changes according to the amount of light hitting the photodiode.) This signal is applied to IC101 RF amp. At the same time, tracking error and focus error detection is done by the photodiode, and those signals are also applied to the RF amp.

The signal is amplified at IC101 and output from pin (20). This signal is called the EFM signal, and besides music data, includes time and location data called the sync signal and Q data, as well as CRC check signal and others.

This signal is applied to IC601, and these signals are written in to the RAM all at once. Next the signals are read out from this RAM and divided into the different types of data mentioned above.

Then CRC check is done and if there are any errors they are corrected.

The music data only is then sent out to IC603 digital filter circuit.

The digital filter removes the sampling frequency component which is contained in the music data, and the sampling frequency is normally more than double the frequency range which is to be sampled. For CD, signals up to 20 kHz are sampled at 44.1 kHz. In order to pass this signal through the low pass filter and play it back, a low pass filter with a sharp curve for cutting the components above 20 kHz is required.

So, the digital filter is used, and by making the intermediate value from the sampled data, it is as if the sampling frequency were doubled, and the sampling frequency becomes 88.2 kHz. Therefore the low pass filter does not need such a sharp curve and circuit structure is easier. After passing the digital filter, the signal goes to IC352 D/A converter.

The D/A converter on this model is the integrated type, and integrates a uniform current at a time width in proportion to input data, to obtain an analog voltage value which corresponds to the data.

This voltage is sample extracted at the analog switch and applied to the low pass filter. This is done alternately for L-CH and R-CH, and the music is played.

Data other than music data is sent to the mechanical computer after CRC check at IC601. Among these data, Q is used as direct search data, and gives high speed access.

The various IC's are explained below.

The role of the master microcomputer IC702:

The master controls all of the operations. It controls key input and remote control input and display, and also sends commands to the mechanical computer, IC701.

Pin Functions

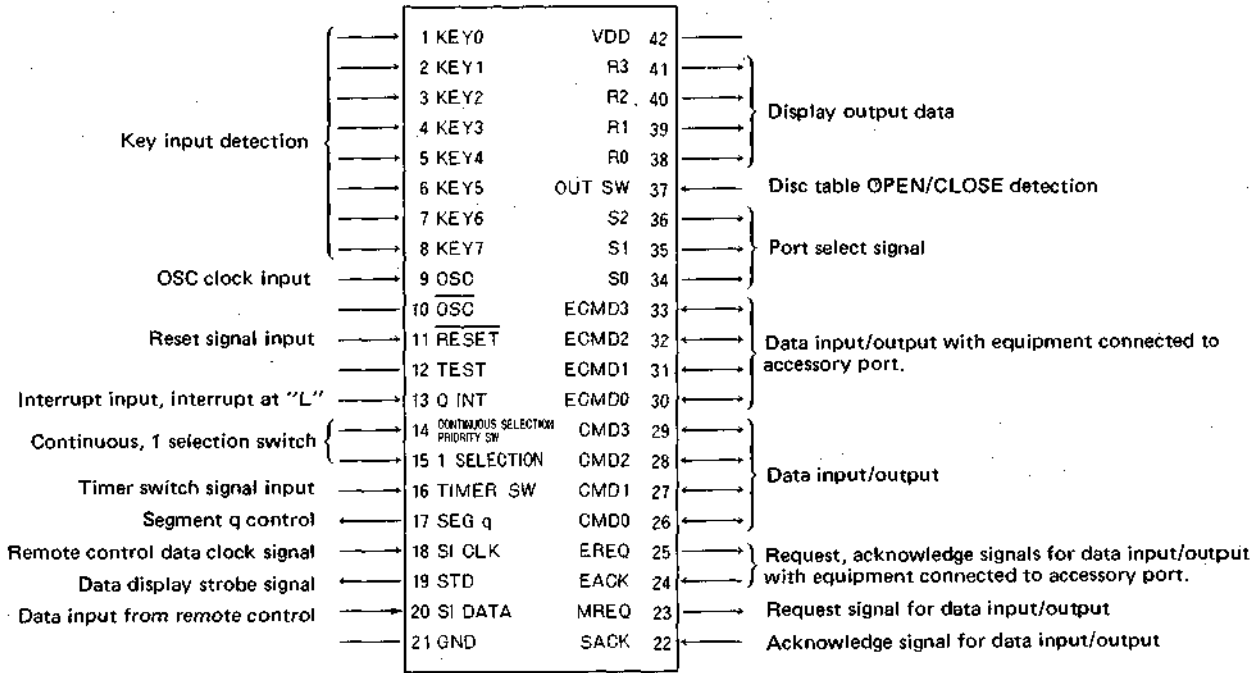

When commands are sent from the master control IC (IC702) to the mechanism control IC, the master control IC sets the data to be sent and makes the M REQ pin go low from high, as shown in the figure. When the M REQ pin goes low, the mechanism control IC (IC701) makes the S ACK pin go low from high. At the time data is taken in to the mechanism control IC (IC701).

When the master control IC (IC702) confirms that the S ACK pin has gone low, it sets the next data and makes the M REQ pin high. When the M REQ pin goes high, the mechanism control IC (IC701) makes the S ACK pin high and reads in the data.

Example: CLOSE command. (CF)

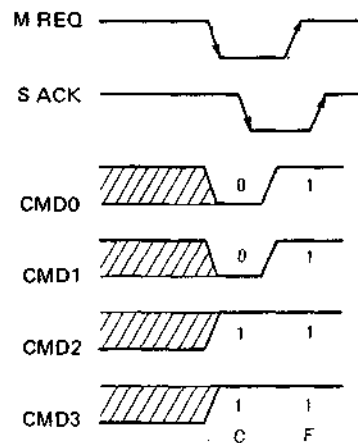

Command from master control IC (IC702) to mechanism control IC (IC701).

Command	
OPEN	DF Opens disc compartment.
CLOSE	CF Closes disc compartment.
AMS	A * * 01F Perform AMS. If for the 5th selection: A0501F <div style="margin-left: 40px;"> * * </div> TRACK NO
INDEX	A * * * * F <div style="margin-left: 40px;"> * * * * </div> TRACK NO INDEX NO Performs index search. When the INDEX key is pressed, TRACK NO and INDEX NO are input and sent.
LOCATION	B * * * * * * * OF <div style="margin-left: 40px;"> * * * * * * * </div> TRACK NO INDEX NO MIN SEC FRAME Performs A → B repeat. The place for A is memorized, that data is put into the * section and set out, the pick-up is returned to the place with that value, and repeats play between that point and the point where B was pressed.
STOP	1F Stops spindle motor and sled motor.
manual search	4F-9F Sends out during FF and REW. 4F FF during PAUSE. Performs 40 track jump after a certain time passes. 5F REW during PAUSE. 6F FF Performs 40 track jump after a certain time passes. 7F REW 8F, 9F not used
PAUSE	3F PAUSE
PLAY	2F normal PLAY command
TOC REQ	* * * * * * * (F) <div style="margin-left: 40px;"> * * * * * * * * * </div> H L MIN SEC MIN SEC (Selection N) (Selection N + 1) This command is sent out when the TOC data in the mechanism control IC is desired, and is sent out during random access, when selection changes, etc.

The above signals are sent from CMD0-CMD3 to the mechanism control IC.

The mechanism control IC executes these commands.

Commands sent from the mechanism control IC (IC701) to the master control IC (IC702).

TOC, Q data	C * * * * * * * * * * F <div style="margin-left: 40px;"> * * * * * * * * * * * </div> TRACK NO INDEX NO MIN SEC FRAME MIN SEC <div style="margin-left: 80px;"> * * * * * </div> elapsed time in the track elapsed time from beginning of disc TOC data or Q data is sent.
TOC READ END	A (F) Sent out when TOC data read-in is finished.
LEAD OUT	B (F) Sent out when disc ends.
NO DISC	E (F) Sent out when there is no disc in the disc compartment.
OPEN	D (F) Sent out when the disc compartment is open.

The mechanism control IC (IC701) keeps the TOC data and Q data read in from the disc, and sends it to the master control IC (IC702) as required.

CDP-502ES/620ES

Display control is done by master microcomputer pins ③④ - ③⑥ (S0 - S2), ③⑧ - ④① (R0 - R3) and 17 (SEG q). R0 - R3 are for data, S0 - S2 are for port select signals of the expansion IC (IC801) and SEG q is for segment q control. Data is displayed by the trigger of pin ①⑨ (STD) signal.

Mechanical Microcomputer (IC701)

This IC controls IC501 and IC601 and commands using pins ②⑥ (DATA), ②⑦ (CLOCK) and ②④ (LATCH). Also, this IC memorizes TOC data and Q data, and direct search, etc. are performed based on this data.

Pin Functions

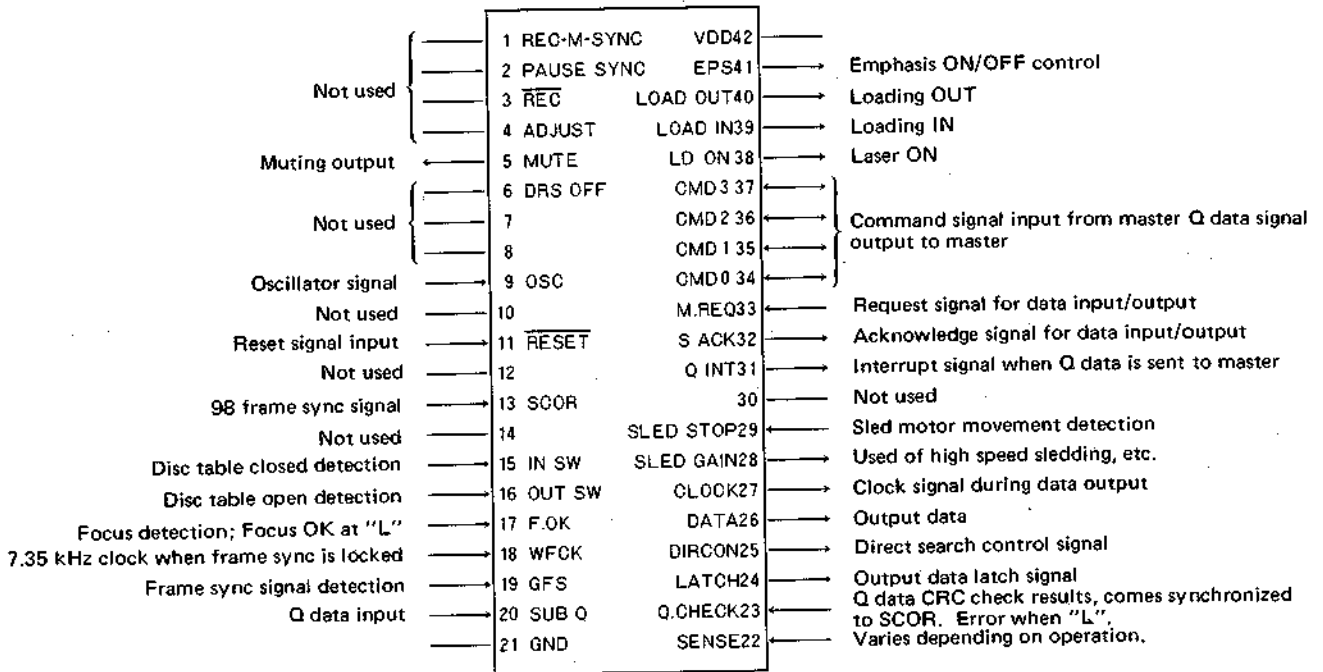

The Q data called subcode Q is used for TOC (Table of Contents) at the lead-in area and mode control signals for preemphasis, etc. and also for display and address data of track number (TNO) and index number, playing time and other information during a selection.

This data is input to mechanism control IC (IC701) SUB Q pin from IC601 and is written in to the RAM in 8 bit units.

The data is sent out as needed from the mechanism control IC701 to the master control IC (IC702) and is displayed on the display tube. Data is sent from the mechanism control IC to the master control IC about 8 times in one second.

1-3. DIRECT SEARCH

On this set, a linear motor is used for the sled motor, so that besides 100, 10 and 1 track jump, the optical pick-up can be moved directly to the address specified by the microcomputer. (direct search). (On the conventional CD player, only the objective lens moves, and the optical pick-up follows it by servo in order to perform 100, 10 and 1 track jump only.) Higher performance access is enabled on this set.

On the conventional CD player, only three data, A0 (MNR of first selection on the disc), A1 (MNR of last selection on the disc) and A2 (leadout track start point) were memorized when TOC data was read in to the microcomputer. However, on this model, the absolute time from the first to the 21st selection is memorized in the microcomputer. This absolute time is converted to track numbers inside the microcomputer, and the track number to be jumped is obtained by subtracting the current address track number from the track number of the selection to be jumped to.

Frame number	POINT	PMIN, PSEC, RFRAME
n	01	00, 02, 32
n+1	01	00, 02, 32
n+2	01	00, 02, 32
n+3	02	10, 15, 12
n+4	02	10, 15, 12
n+5	02	10, 15, 12
n+6	03	16, 28, 63
n+7	03	16, 28, 63
n+8	03	16, 28, 63
n+9	04	. .
n+10	04	. .
n+11	04	. .
n+12	05	. .
n+13	05	. .
n+14	05	. .
n+15	06	49, 10, 03
n+16	06	49, 10, 03
n+17	06	49, 10, 03
n+18	A0	01, 00, 00
n+19	A0	01, 00, 00
n+20	A0	01, 00, 00
n+21	A1	06, 00, 00
n+22	A1	06, 00, 00
n+23	A1	06, 00, 00
n+24	A2	52, 48, 41
n+25	A2	52, 48, 41
n+26	A2	52, 48, 41
n+27	01	00, 02, 32
n+28	01	00, 03, 32
.	.	. .
.	.	. .
.	.	. .

- Frame number: 98 symbol, 1 block No.
- POINT = For A0, PMIN indicates MNR of first selection on the disc. PSEC, PFRAME are "00".
- POINT = For A1, PMIN indicates MNR of last selection on the disc. PSEC, PFRAME are "00".
- POINT = For A2, PSEC, PFRAME indicate lead-out track start point.
- POINT = For 01-06, PMIN, PSEC indicate the absolute time of the selection.

Table A. TOC Structure (Example of a 6 selection disc)

Direct search is performed as follows:

When the search command is input to the mechanism control to (IC303) from the master control IC (IC302) due to key input or remote control input, the mechanism control IC303 converts the current address to track number from the data Q of the current address channel Q (Figure 1) data. (This data Q is always input from pin 20 SUB Q during play.) The address to be jumped to is also converted to a track number, the track numbers are compared, and the number of tracks to be jumped is calculated.

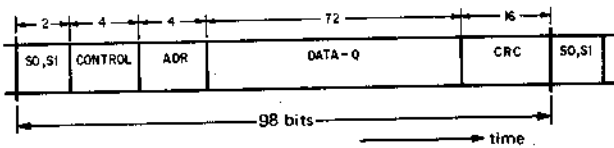

- S0, S1: parts of sync pattern.
- CONTROL: Indicates channel number and preemphasis ON/OFF.
Output from MSB
0000 - 2CH, no preemphasis
1000 - 4CH, no preemphasis
0001 - 2CH, preemphasis
1001 - 4CH, preemphasis
LSB = 0 at lead-in and lead-out portions.
- ADR: Control bit for DATA-Q. Output from MSB.
- DATA-Q: 72 bits of data; output from MSB.
- CRC: CRC for CONTROL, ADR, DATA-Q. Refer to PCM-F1 Operation Manual for details on CRC.
Output from MSB.
Generation multinominal is
 $P(x) = x^{16} + x^{12} + x^5 + 1$

Figure 1. Channel Q Structure

- Data Form on Lead-in Track (indicate TOC) -

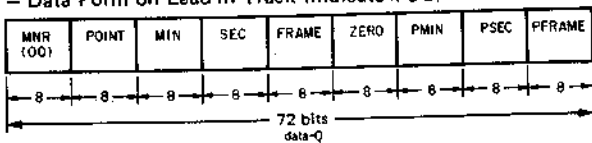

- Data Form of Music Signal and Lead-out Track -

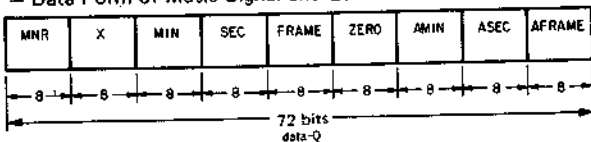

- MNR: Expresses Music Number as 2 digits of BCD.
00 → Lead-in track
01-99 → Music number
AA → Lead-out track
- X: MNR index, expressed as 2 digits of BCD.
1 MNR is divided into 100. The method of division is determined by the software, and numbering is in order from "00-99". Does not exist on lead-in track.
00 → Pause encoding
Applies pause. There is 2-3 seconds of pause encoding at the top of the selection.

01-99 → Sub-division number.

X = 01 on the lead-out track, MNR = 01-99 and X ≠ 00 during a selection. Initial value is "01", then increases by ones.

ZERO: All these 8 bits are "0".

MIN, SEC, FRAME: Selection running time is expressed by BCD 6 digits. All "0" at beginning of selection. Time increases during the selection, stops at pause. Become "0" at end of pause. Time increases on lead-in and lead-out tracks. 1MIN = 60 SEC, 1SEC = 75 FRAME (00-74)

AMIN, ASEC, AFRAME: Disc running time is expressed as BCD 6 digits. At start of disc program area, time is "0" and MNR is the first value of that disc.
1AMIN = 60 ASEC, 1ASEC = 75 AFRAME (00-74)

POINT, PMIN, PSEC, PFRAME: Disc table of contents is on this part of the lead-in track. As shown in the table, it is recorded continuously and repeatedly on the lead-in track, or MNR = 00 portion. Also, each content is recorded 3 times each.

PMIN, PSEC, PFRAME values each express selection start point. There is ±1 second precision on AMIN, ASEC, AFRAME time axes.

Figure 2. Data Q Structure

Next, the mechanism control IC puts the digital signal processing/CLV servo IC (IC307) CX23035 into counter set mode. By doing this, CX23035 outputs the CNIN pin (17) input signal CNIN/2h (Hz) signal from SENSE pin (18) (COUNT). At this time 41 is set in n, so a signal which is the input signal divided by 82 is output from the SENSE pin.

Then tracking and sled servo go off, focus servo goes on and the optical pick-up is moved quickly by the linear (sled) motor. When this happens the RF amp (IC201) CX20109 MIRR pin (18) mirror output is as shown in Figure 3. (For example, if there are 20000 tracks from the innermost to outermost circumference, and access is done in 0.5 seconds, mirror output is 40 kHz, which is too fast for the mechanism control IC to read.)

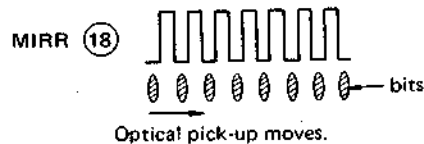

Figure 3. Mirror Output for Direct Search

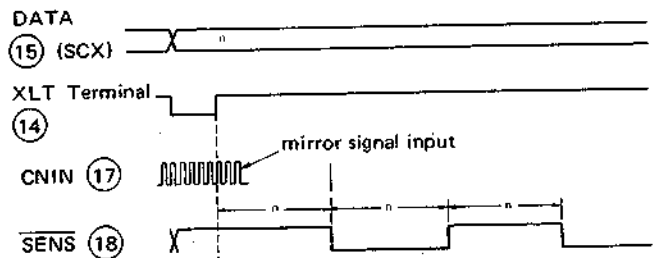
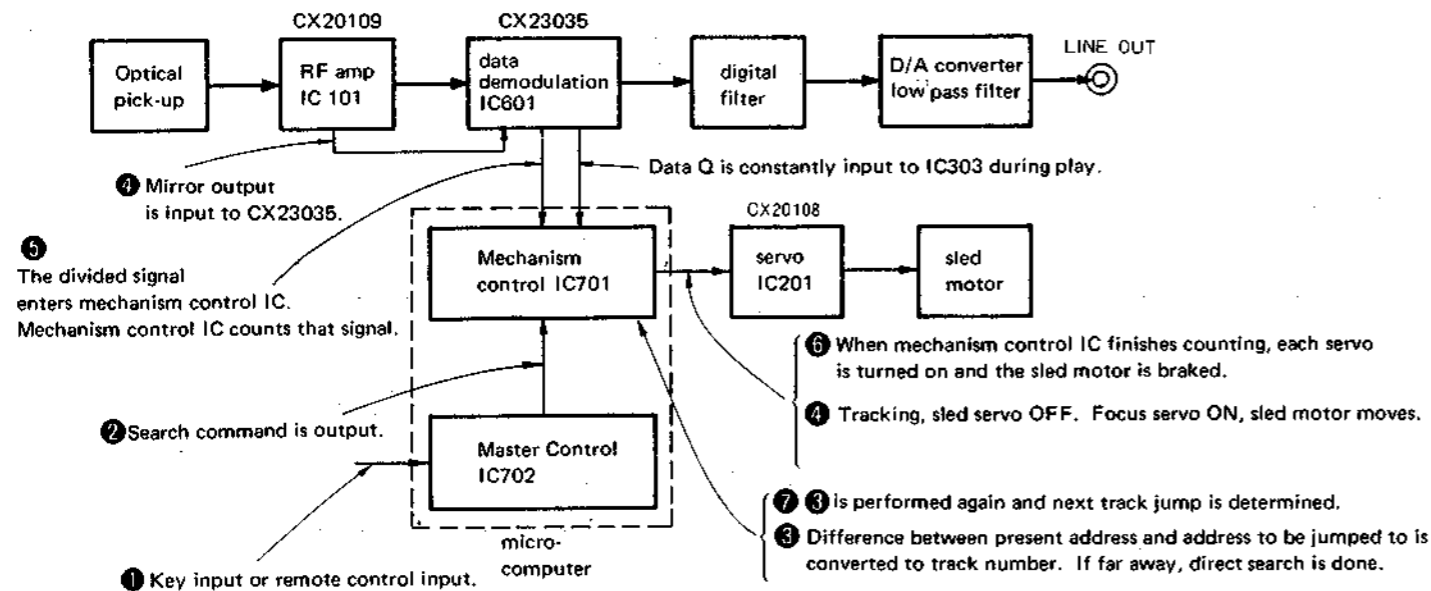
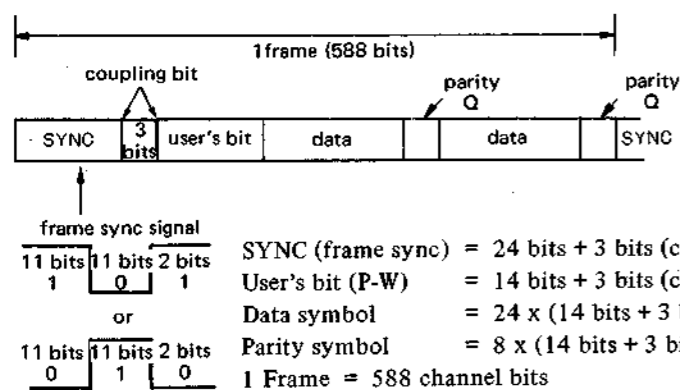

Figure 4. Count Signal Timing

This mirror output is input to CX23035 CNIN pin 17, then is divided into 41 and output from SENSE pin 18 to the mechanism control IC SENS pin 22. (At this time, it is divided and can be read.) This input signal is counted by the mechanism control IC at rise or fall and is converted to the number of tracks to be jumped. For example, for a 1000 track jump, consecutive comparison, such as $1000/82 \approx 12$ is done and when that value is reached, each servo is turned on and the optical pick-up is braked. Then DATA-Q is read, converted to track number, and if within a certain range, 100, 10, 1 track jump are performed and convergence is done. Outside of that range, direct search is performed again.



Frame Structure of EFM Modulated Recorded Signal



The CD player can read out (1 frame (588 bits) x 98 frames x 75) in one second. $98 \text{ frames} \times 75 = 7350$ SYNC (frame sync signal) identifies the beginning of the frame during playback, and is for frame sync, and a 24 bit pattern is used so that it will not be generated during other signals.

The time of 1 frame is $136.05 \mu\text{sec} (1/7350)$, so the frame repeat frequency is 7.35 kHz. This sync signal is applied to mechanism control pin 18 during frame sync lock.

The channel bit frequency is $7.35 \text{ kHz} \times 588 = 4.3218 \text{ MHz}$.

The user's bit, of which there is one symbol in each frame, is called a subcode, and 98 symbols are gathered to form one data block (subcode frame).

The subcode has 8 channels, P, Q and R - W, and the 8 bits in one symbol are composed of one bit from each channel.

P is used as selection dividing mark, and Q is used for TOC (Table of Contents) at the lead-in area and for the mode control signal preemphasis and also for display and address data of track number (TNO), index number, playing time and other information during a selection.

The data is renewed for each of these every 98 frames, or every 1/75 seconds.

EFM converts 8 bit data to 14 bits and modulates. For 8 bit data 1 and 0, there are $2^8 = 256$ combinations, and for 14 bit data, it is $2^{14} = 16384$.

For EFM, relative to the 8 bit data pattern, "more than 2 0's between bit 1 and 1, but less than 10" is selected from the 14 bit data pattern.

3 bit coupling bits are inserted between the converted 14 bit blocks. 1 symbol 8 bit data bit includes a coupling bit and is converted to 17 bits. The converted bit is called a channel bit.

When 14 bits and 14 bits are coupled, the coupling bit has more than two 0's.

IC352 D/A Converter

A 16 bit serial signal is input to pin 10 (DIN) as the data. The data synchronizes to the rise of pin 9 (BCLK) and is taken into the IC from the MSB, in order.

At the 17th fall of BCLK, if pin 8 (WCLK) goes from high to low, the 16 bit data is transferred from the shift register to the latch.

Each channel's data is taken in from the 17th one. When pin 11 (LRCK) is low, R-CH data is taken in. When pin 11 (LRCK) is high, L-CH data is taken in.

Data output is R-CH signal output from pins 18 (IOUTL) and 23 (DCL) when LRCK is low.

When LRCK is high, R-CH signal is output from pins 17 (IOUTR) and 15 (DCR).

The data transferred to the latch is set in the counter.

Current flows from IOUTL or IOUTR by integrated current start signal, but the counter determines the flow time.

Data is preset in the counter, and counting is started from that value. After counting, and after counting offset, output is stopped by the integrated current stop signal.

In this way the digital signal is converted to analog.

DCR and DCL are for discharging the voltage charged during integration and are output before integrated current start.

Q301 and Q401 are FET for discharging.

IC355

IC355 performs signal switching, and switches L-CH and R-CH alternately at high speed.

The truth table is shown below. On this set A and C are connected, so there are only two methods of use, 1 and 2.

IC352 pin 11 (LRCK OUT) is connected to IC355 pins 9 (C) and 11 (A), and LRCK OUT signal is output synchronized with LRCK, and this signal switches L-CH and R-CH.

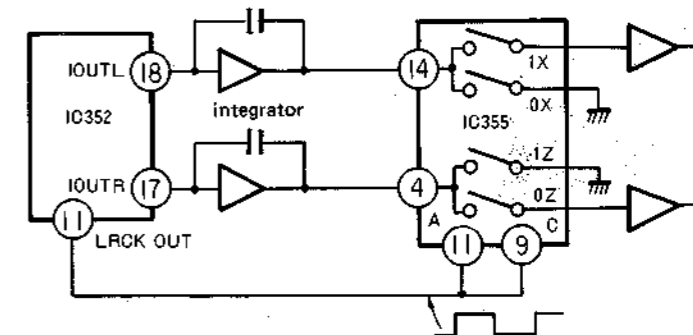

Truth Table

	CONTROL INPUTS				Pins which go ON
	INHIBIT	C	B	A	
①	L	L	L	L	0X, 0Y, 0Z
	L	L	L	H	1X, 0Y, 0Z
	L	L	H	L	0X, 1Y, 0Z
	L	L	H	H	1X, 1Y, 0Z
	L	H	L	L	0X, 0Y, 1Z
②	L	H	L	H	1X, 0Y, 1Z
	L	H	H	L	0X, 1Y, 1Z
	L	H	H	H	1X, 1Y, 1Z
	H	*	*	*	NONE

SECTION 2
BLOCK DIAGRAM

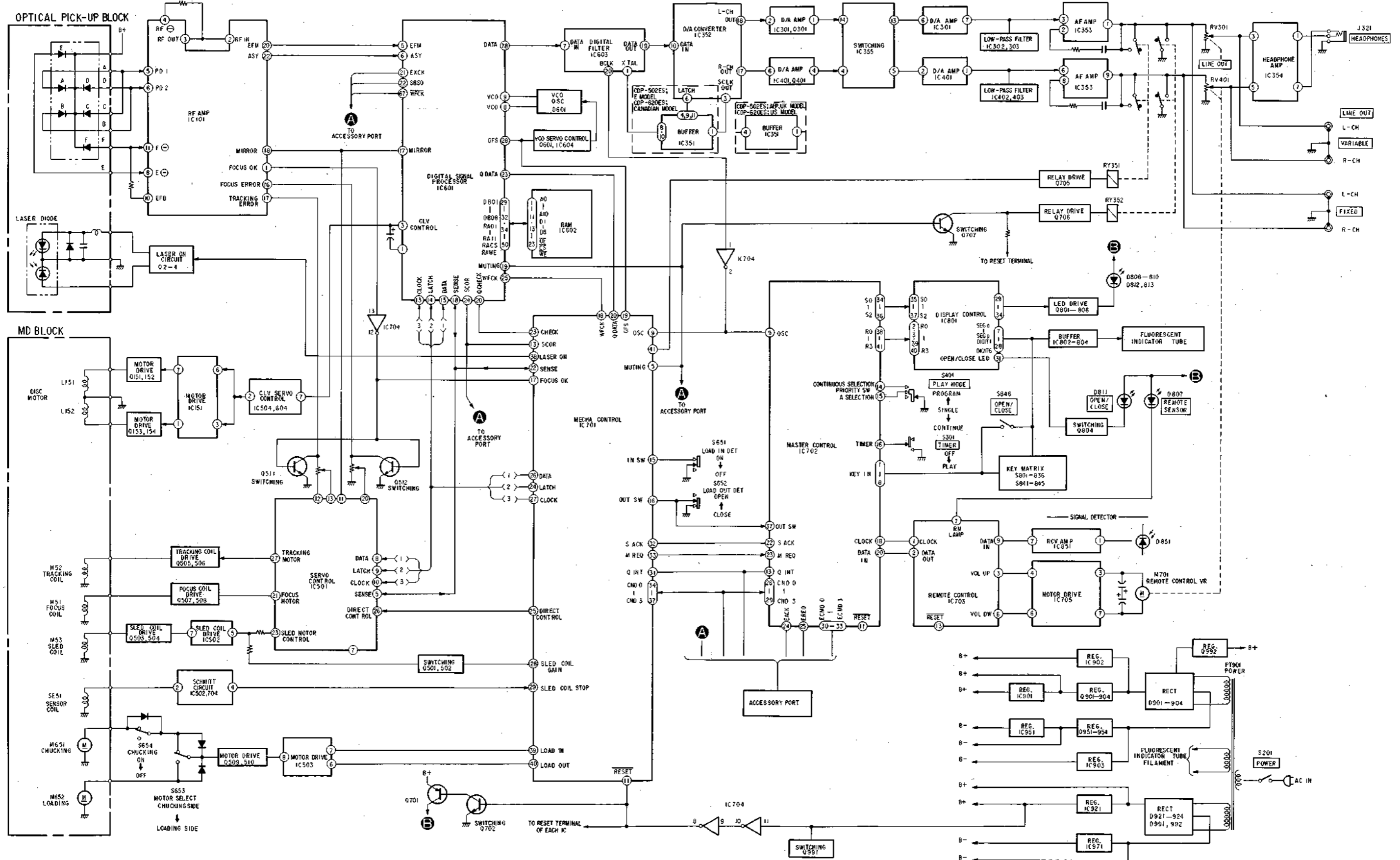

SECTION 3
DISASSEMBLY

3-1. DISASSEMBLY

Note: Follow the disassembly procedure in the numerical order given.

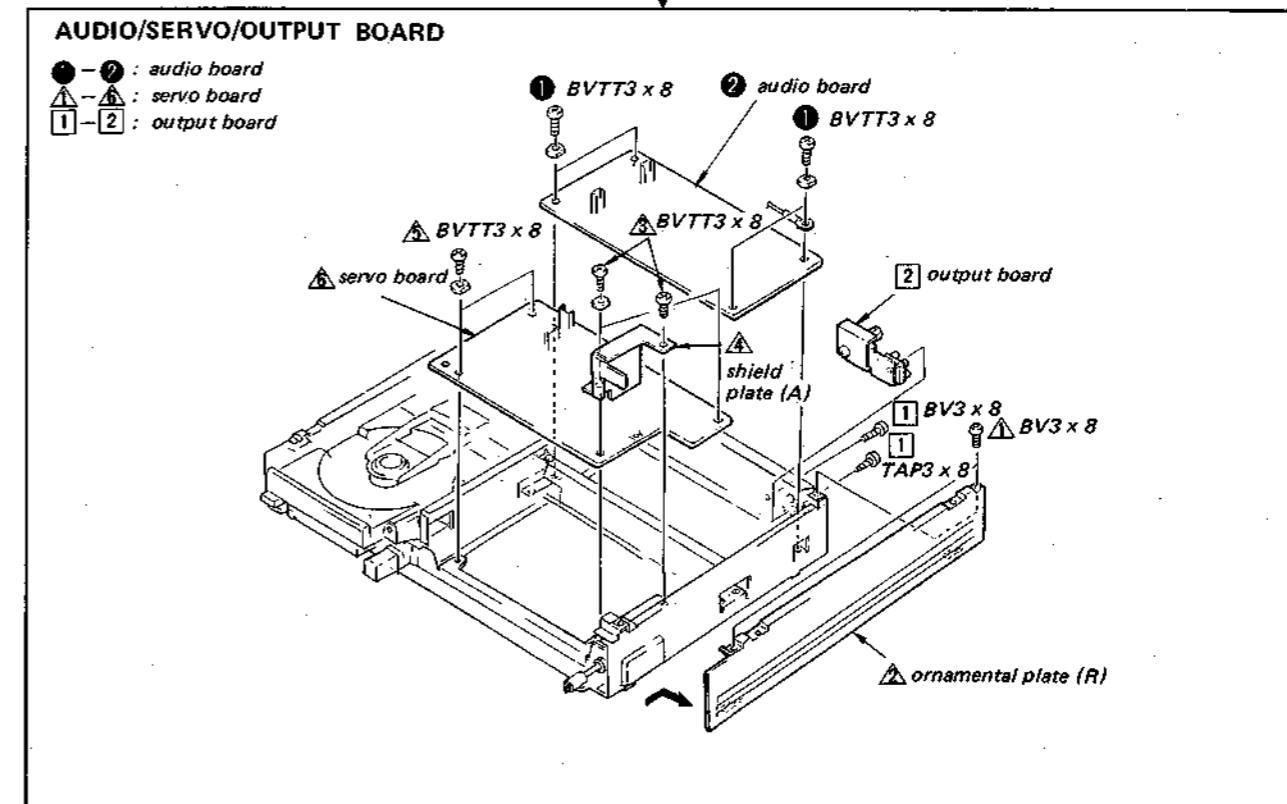
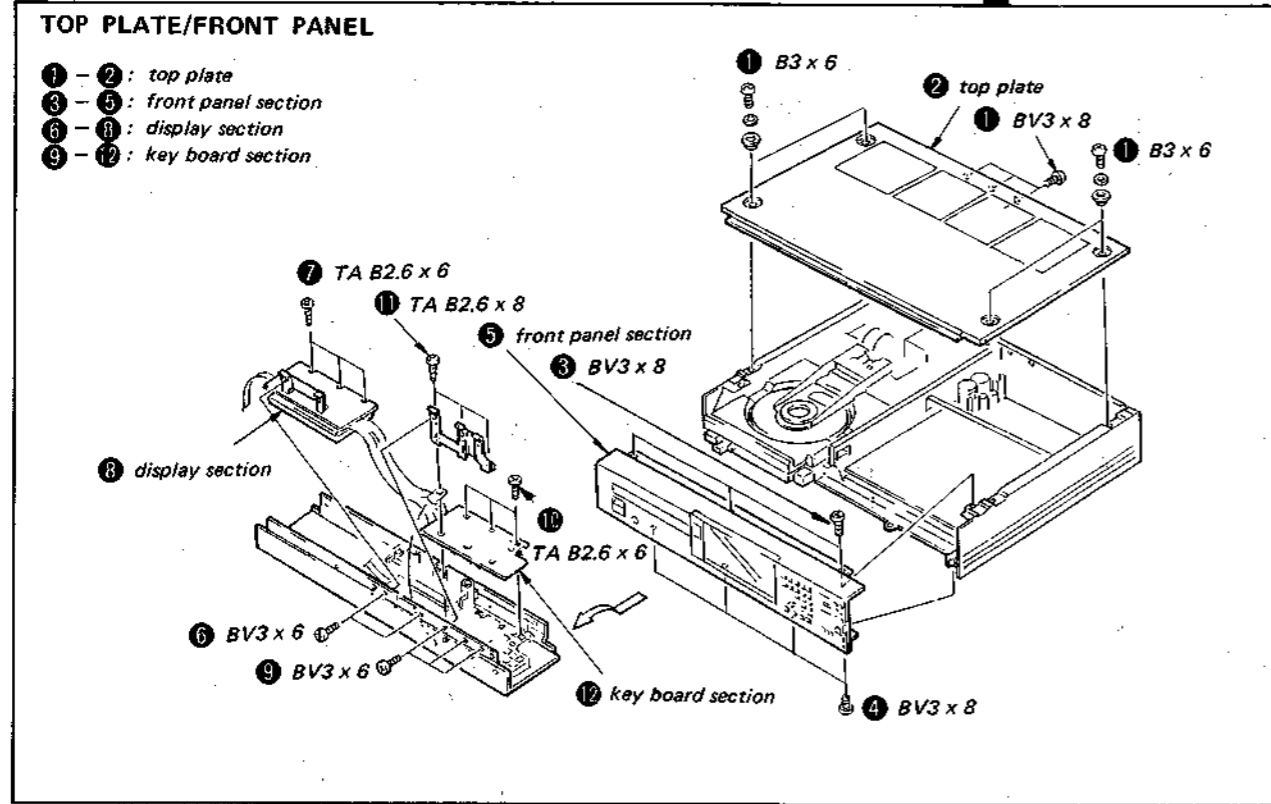

• Remove bottom plate.

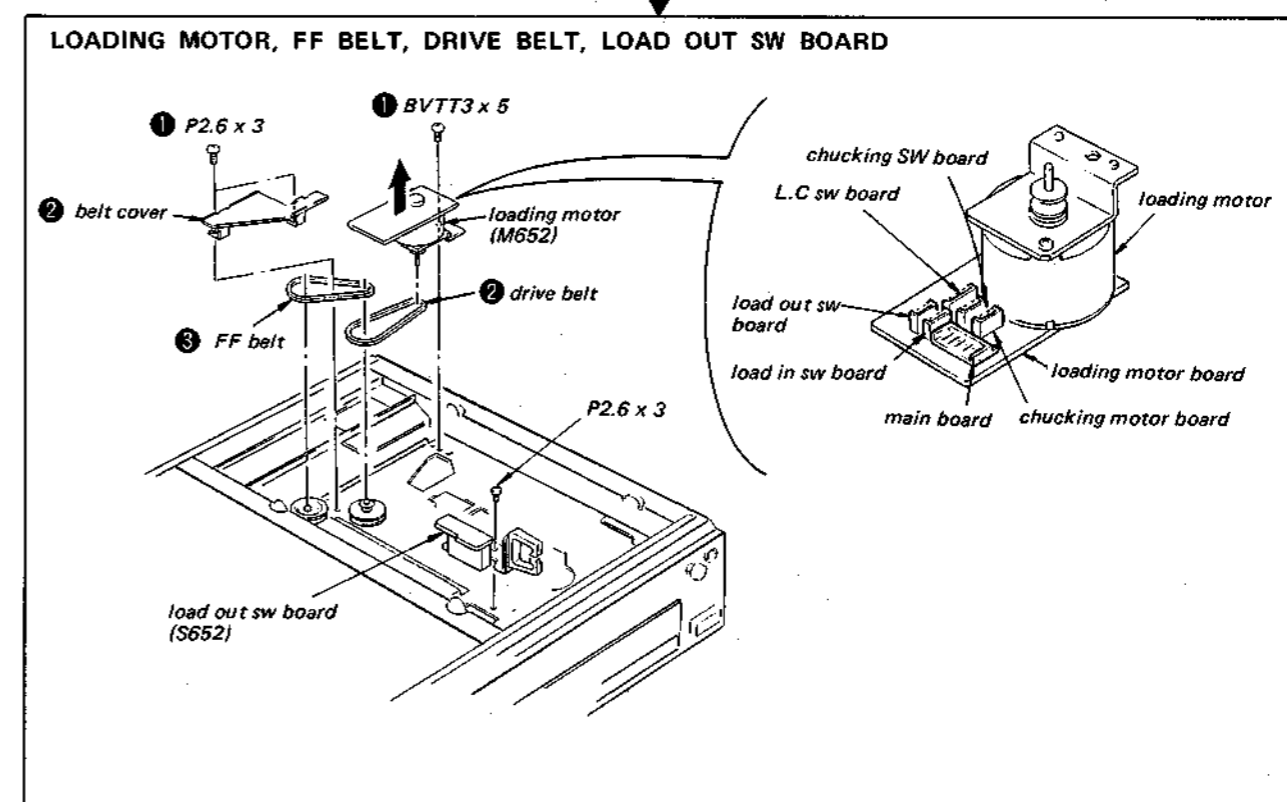
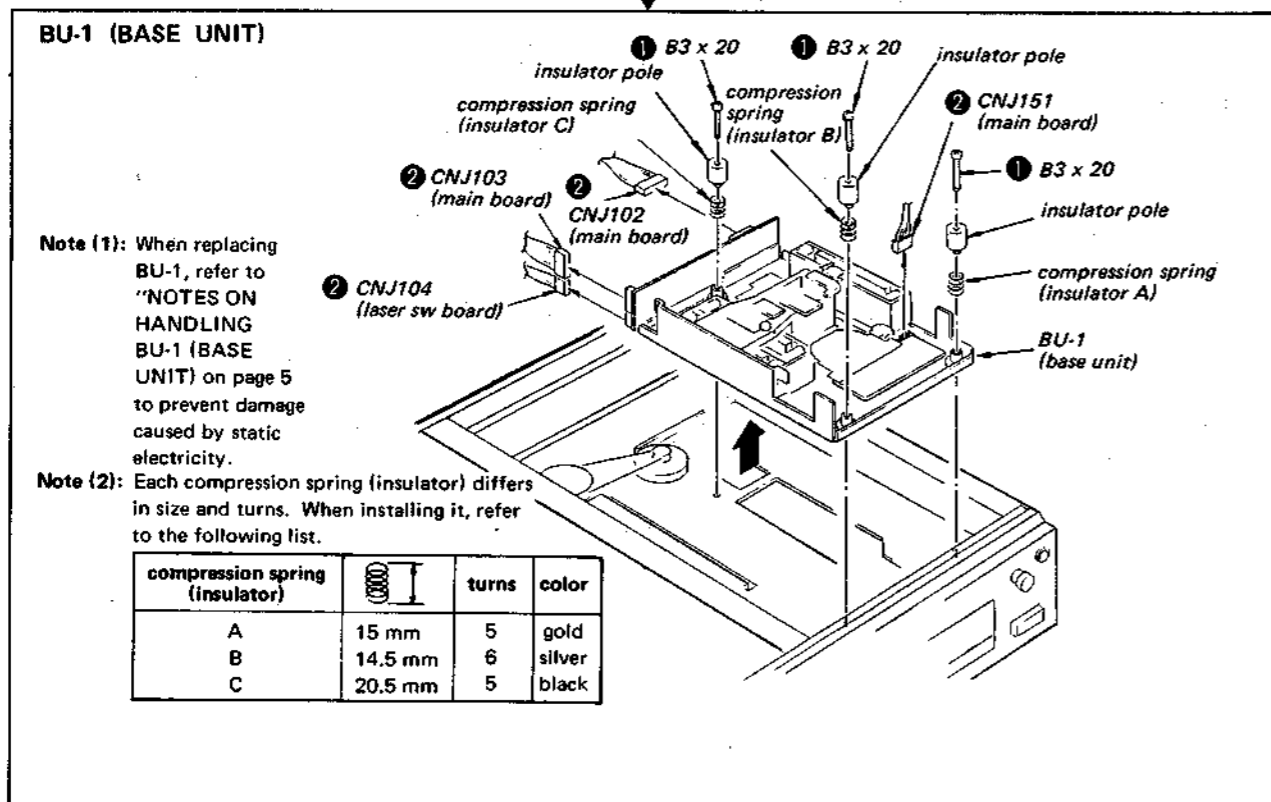

SWITCH BOARD

- All wires of each sw board are connected to loading motor board (page 26).

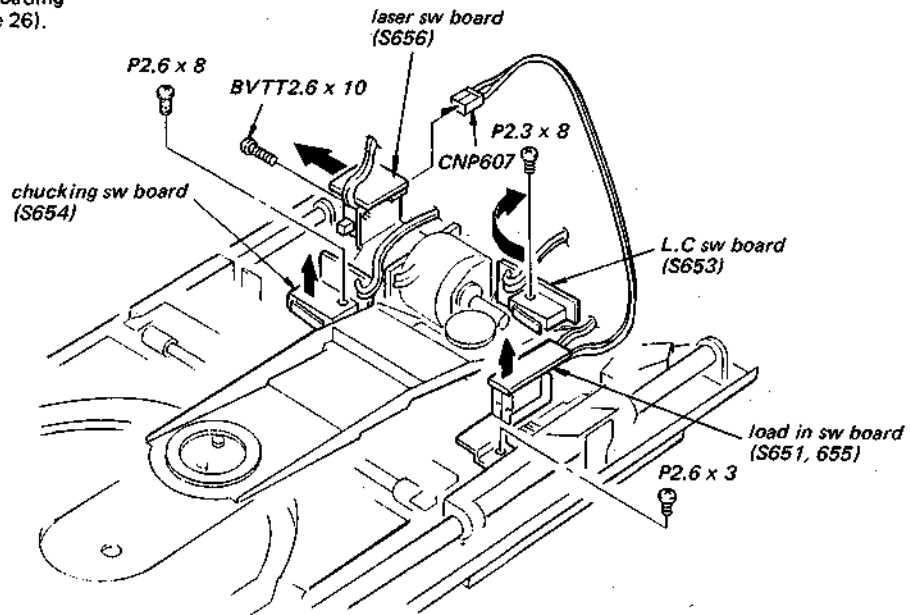

BSL MOTOR BOARD

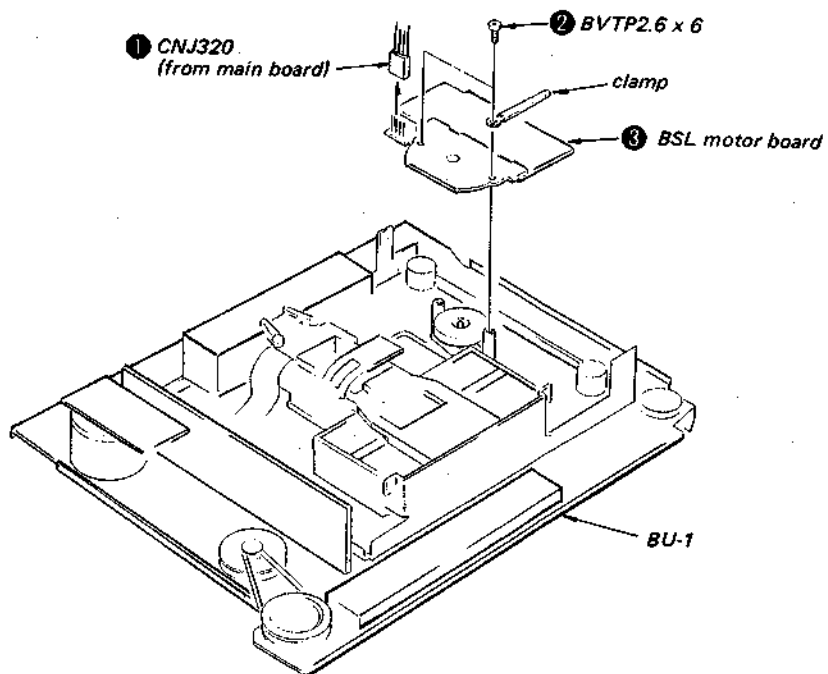

MD SECTION

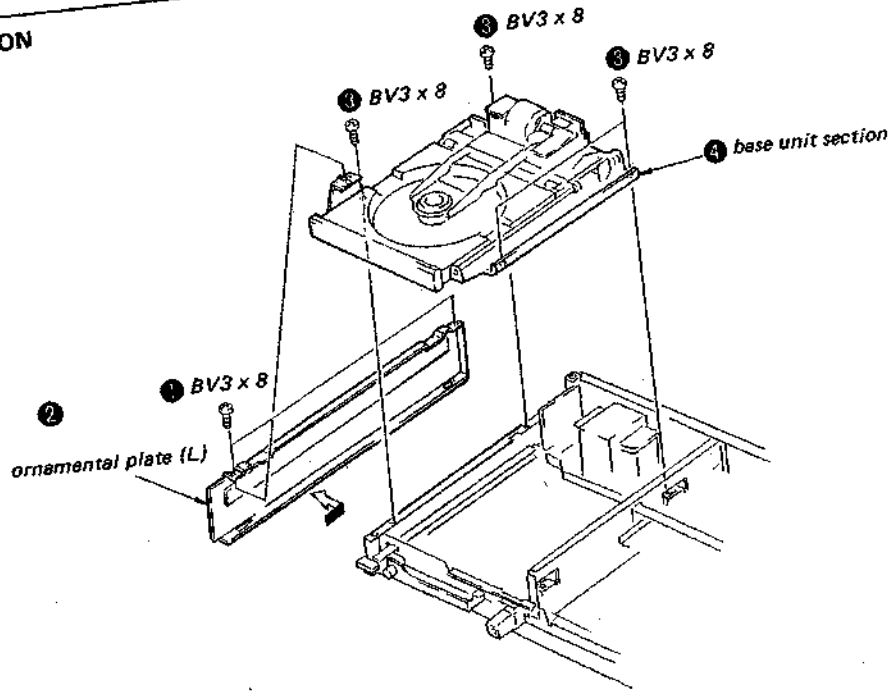

CHUCKING MOTOR

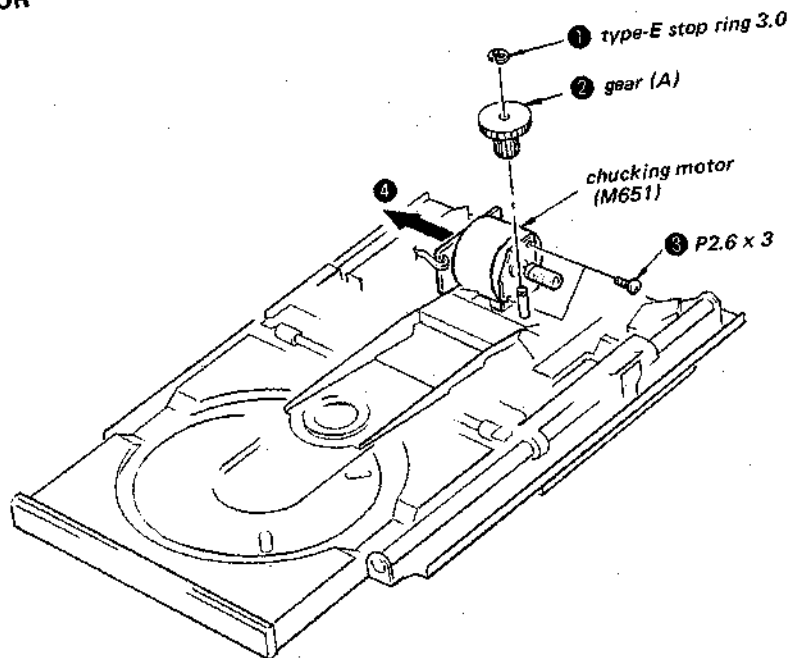

ROPE STRINGING

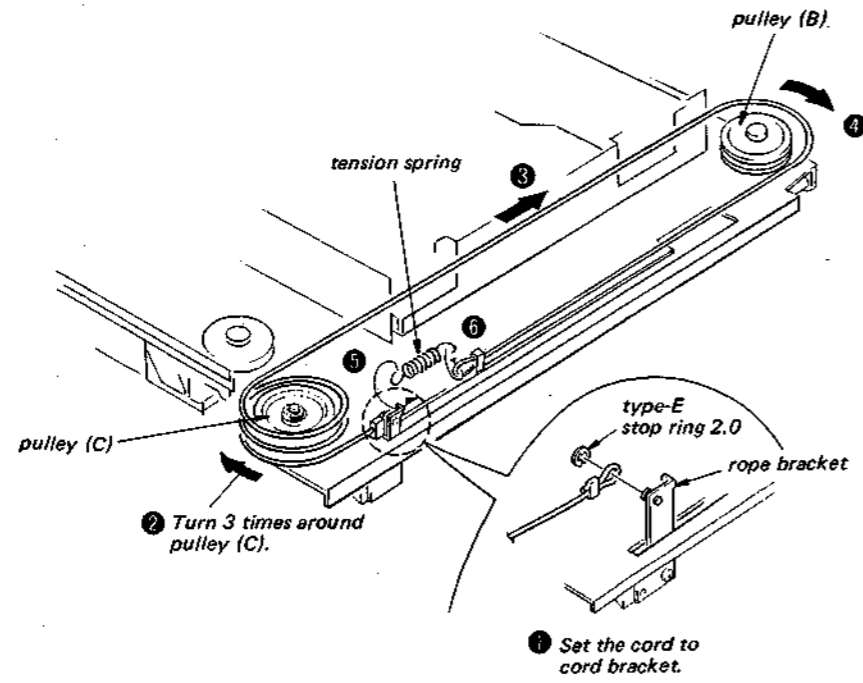

FLEXIBLE BOARD

Unsolder • marked portion of ref. no. 3, 5, and 6 and remove flexible board.

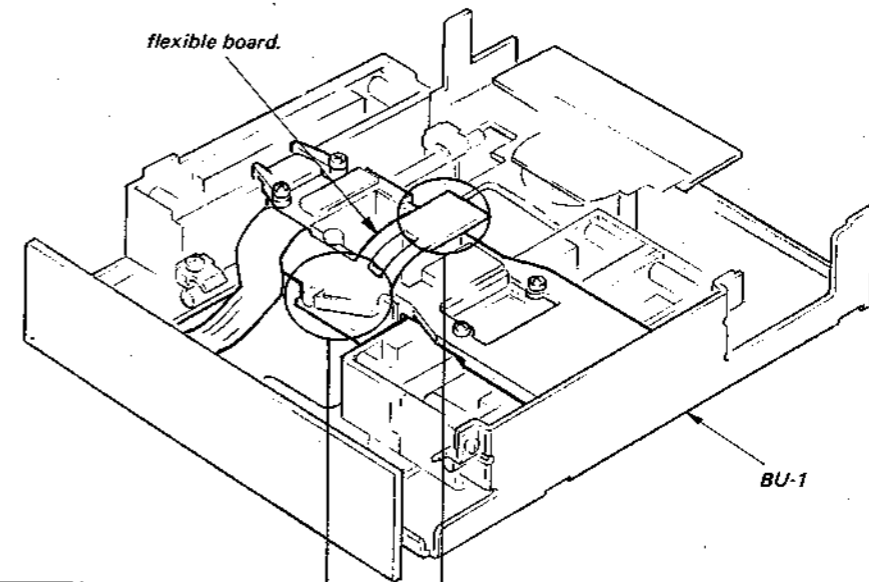
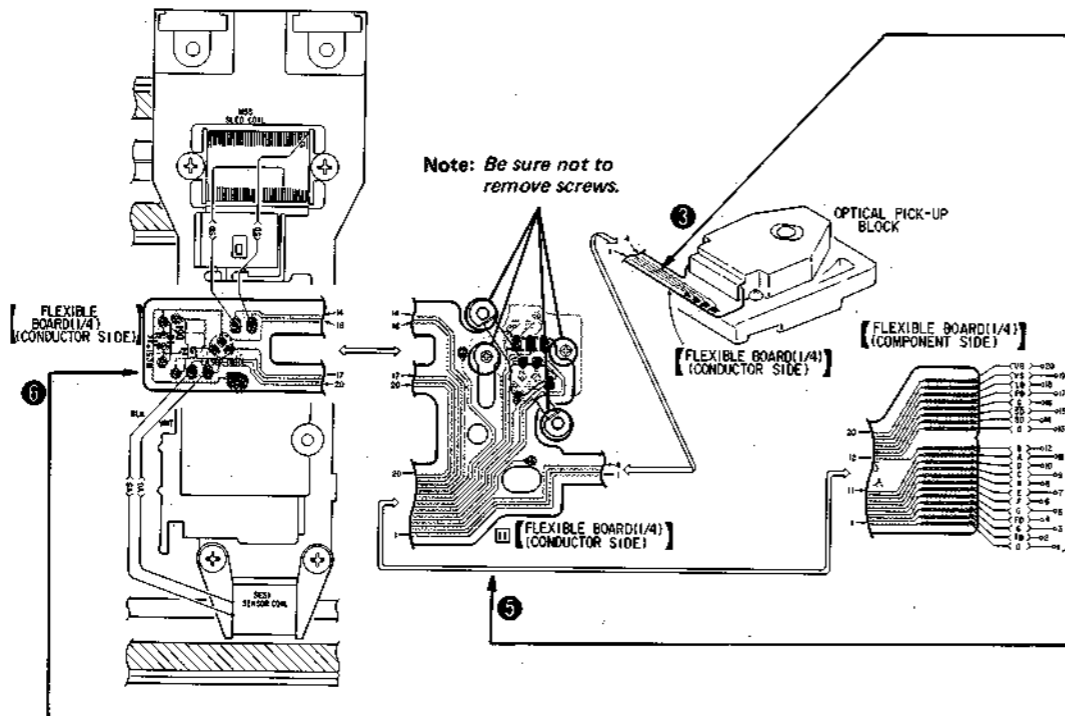
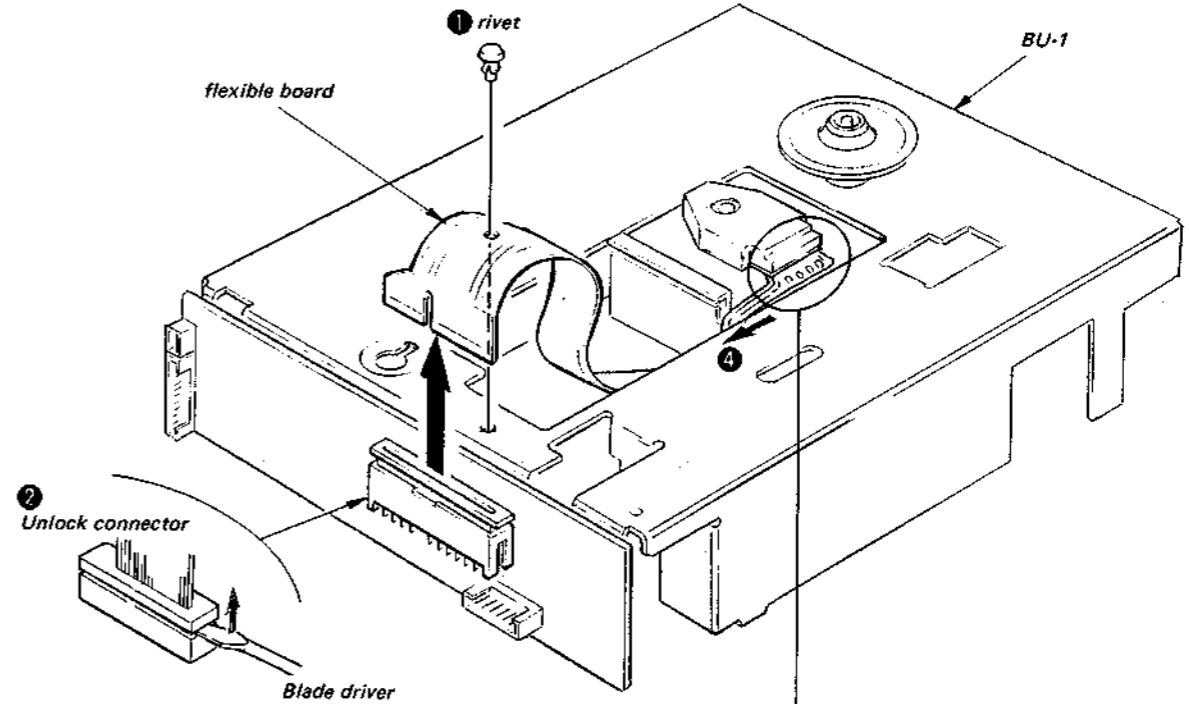

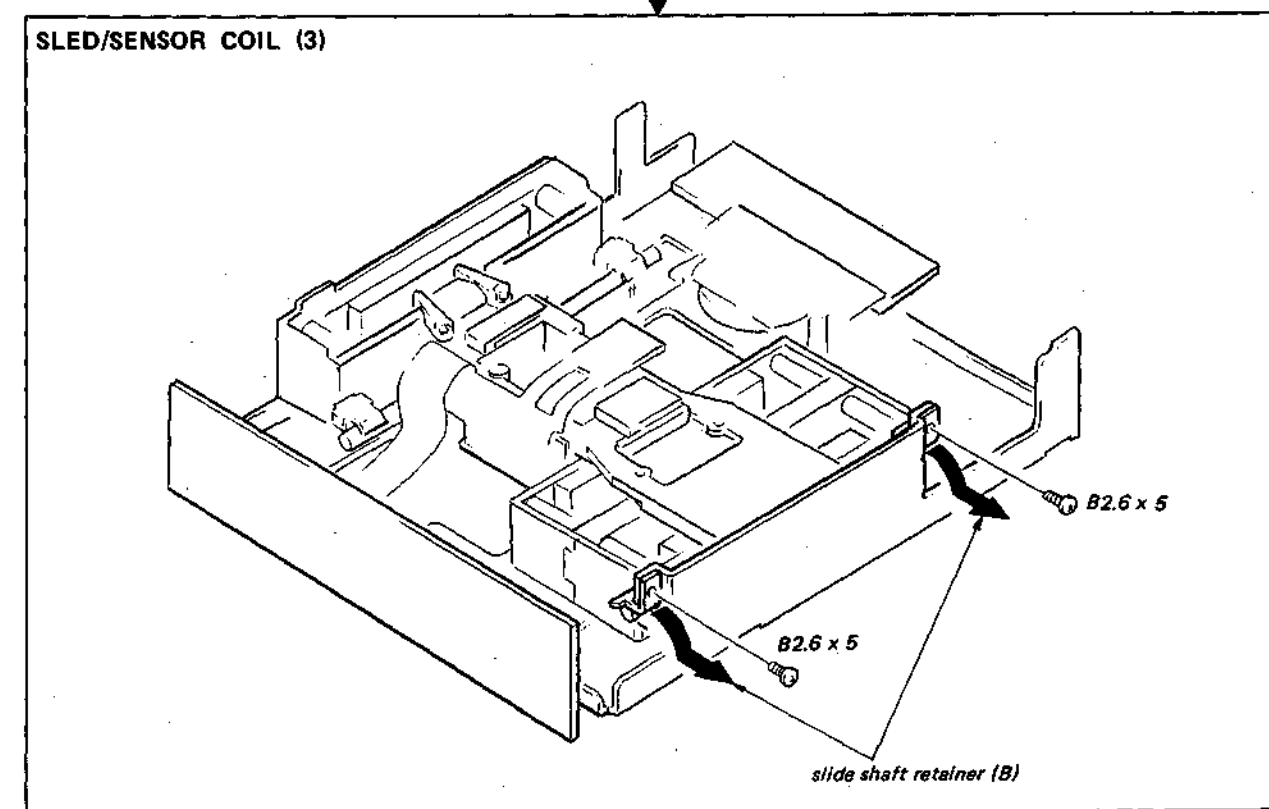
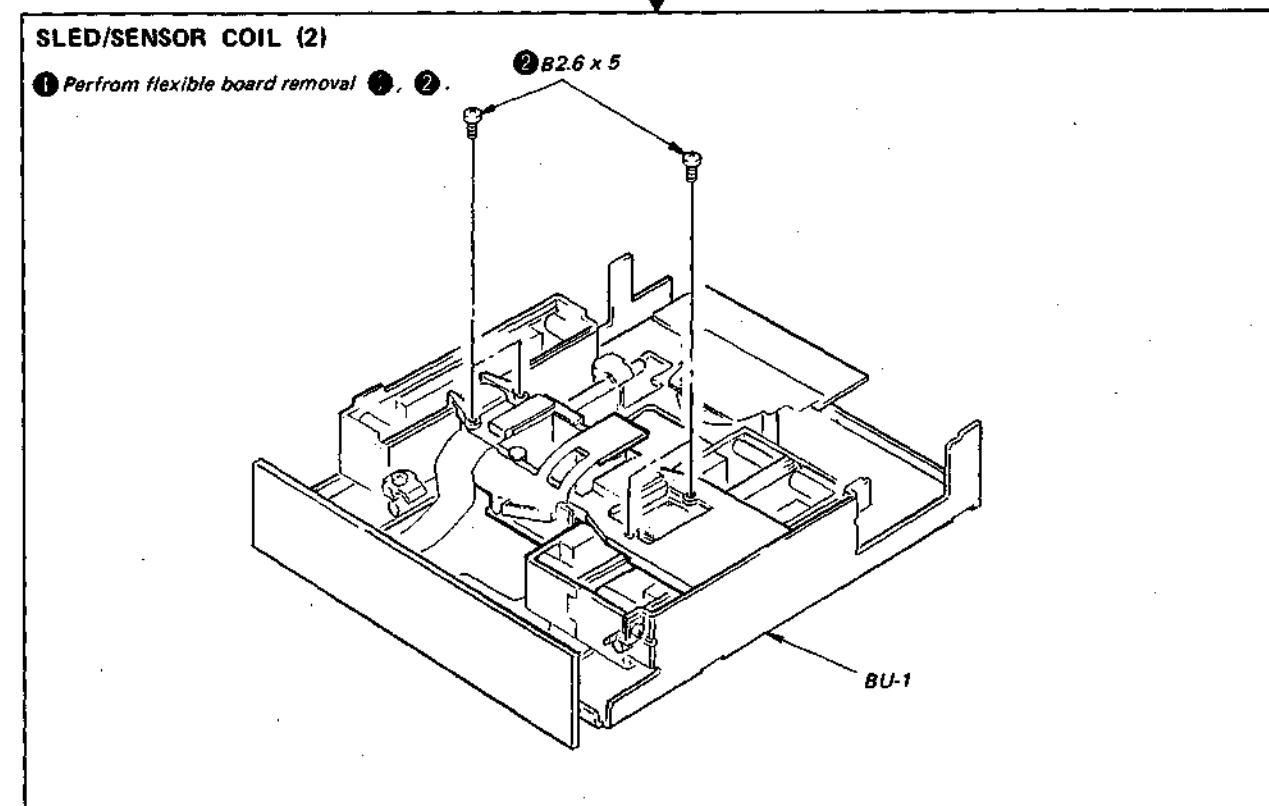
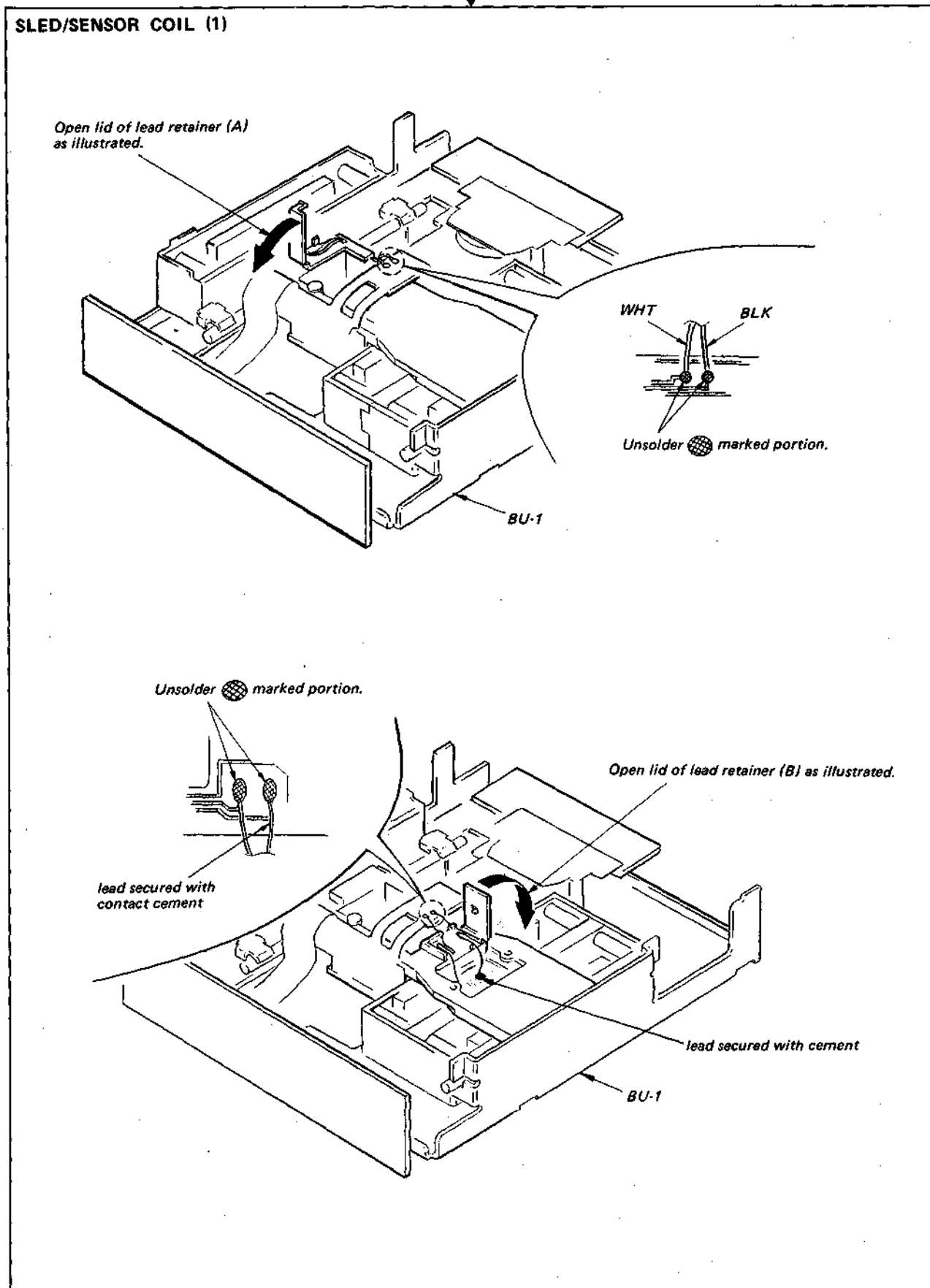

SLED/SENSOR COIL (5)

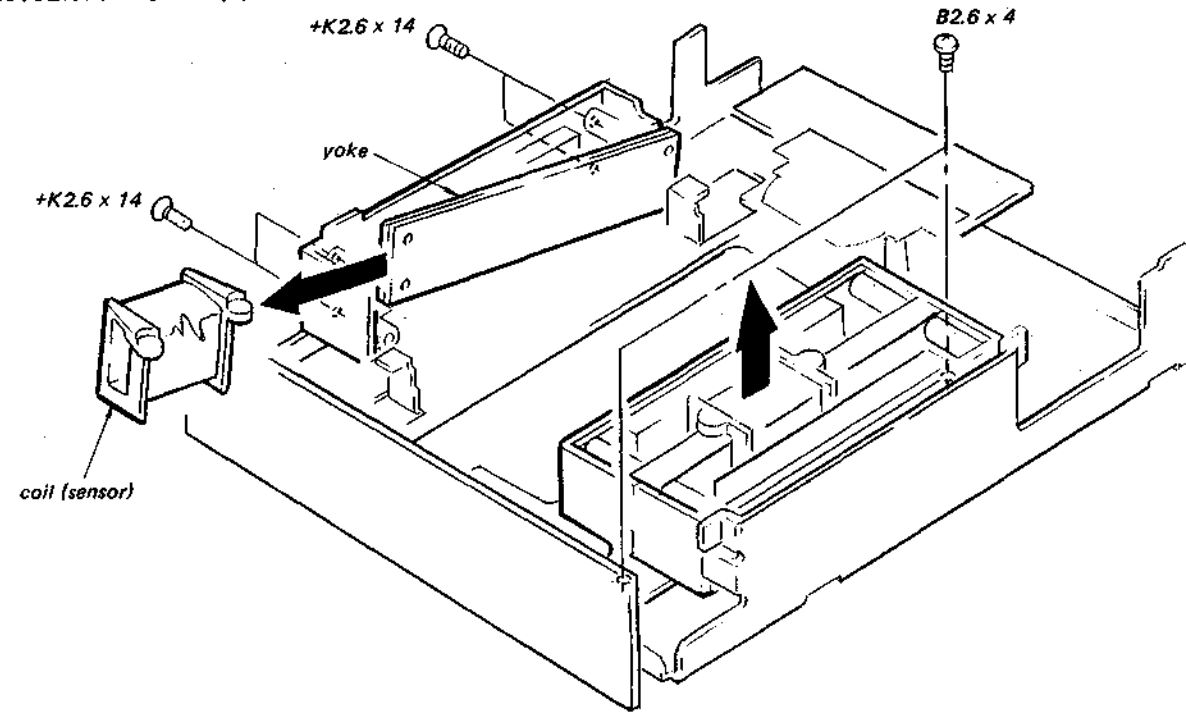

Note: When installing sled coil, install as illustrated. If it is installed incorrectly, it will not operate.

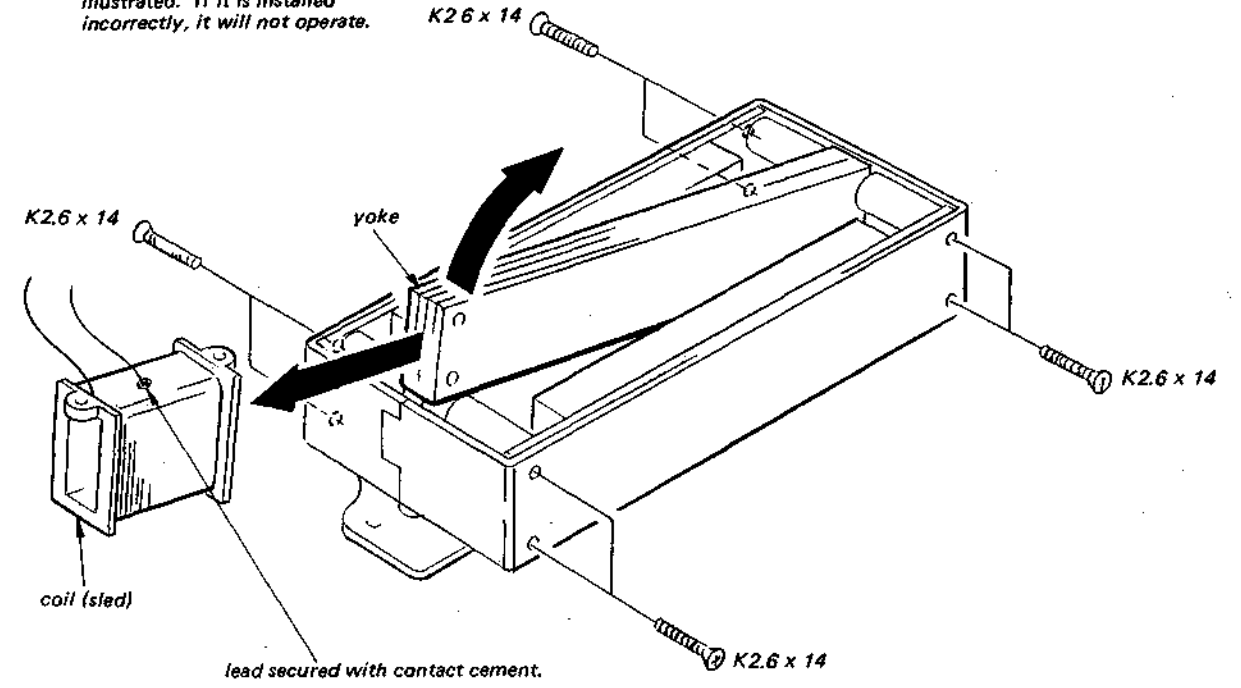

SLED/SENSOR COIL (4)

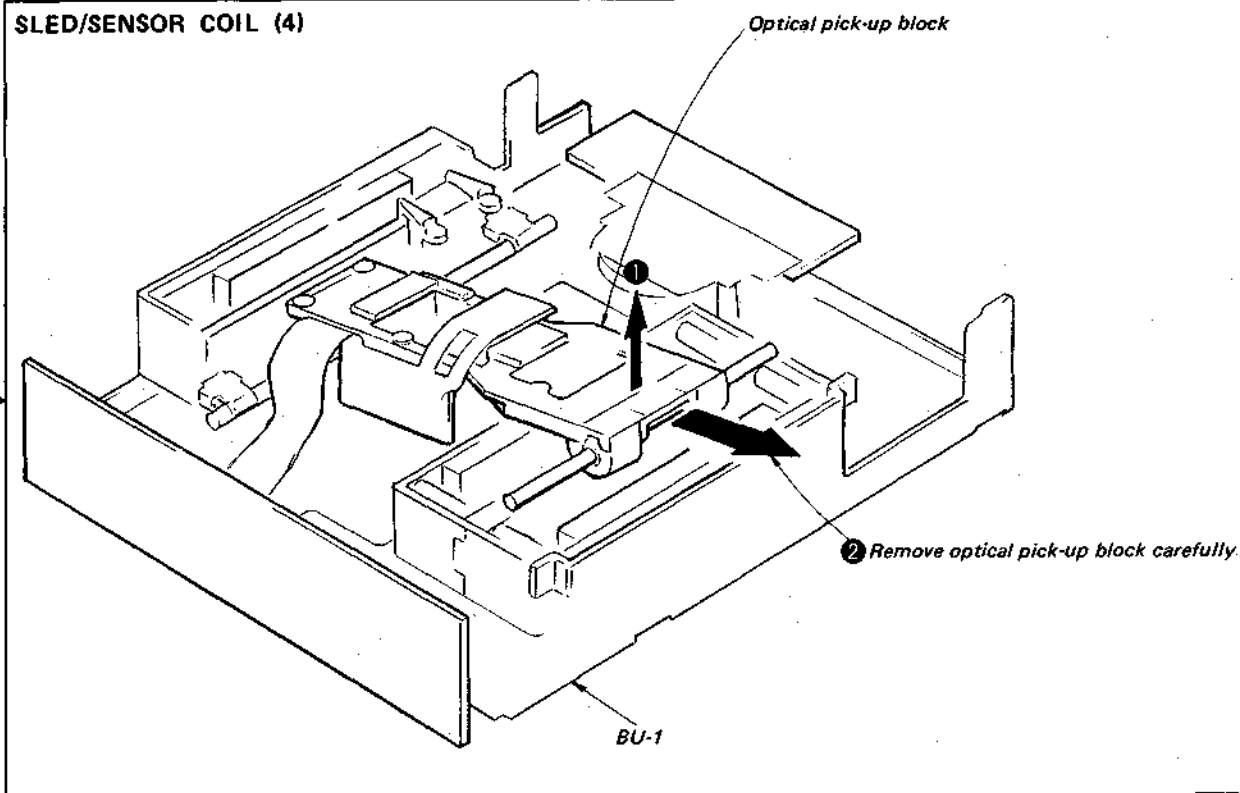

3-2. PC BOARD LAYOUTS

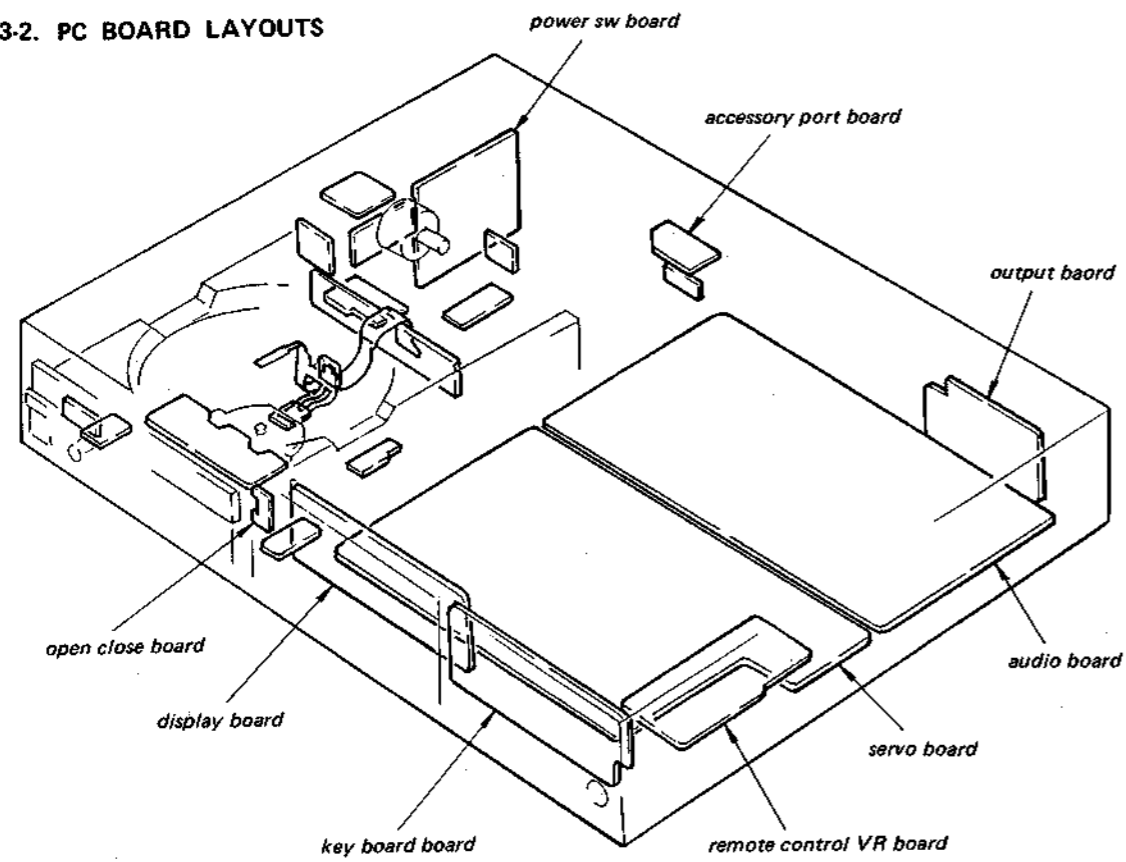

MECHANICAL SECTION

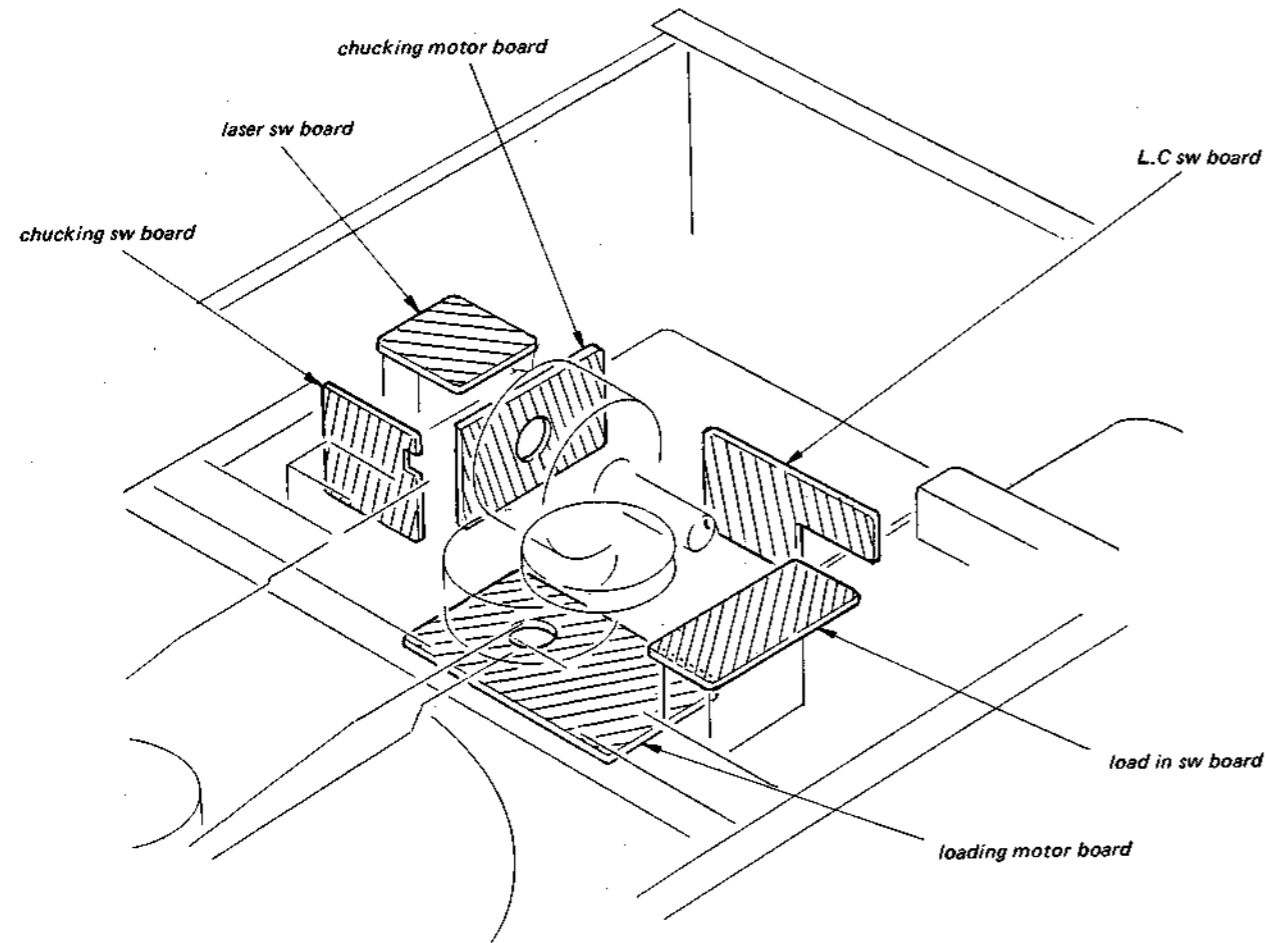

4-1. MECHANICAL ADJUSTMENT
DISC TABLE POINT ADJUSTMENT

Setting:

- Turn power on.
- Keep disc table closed.

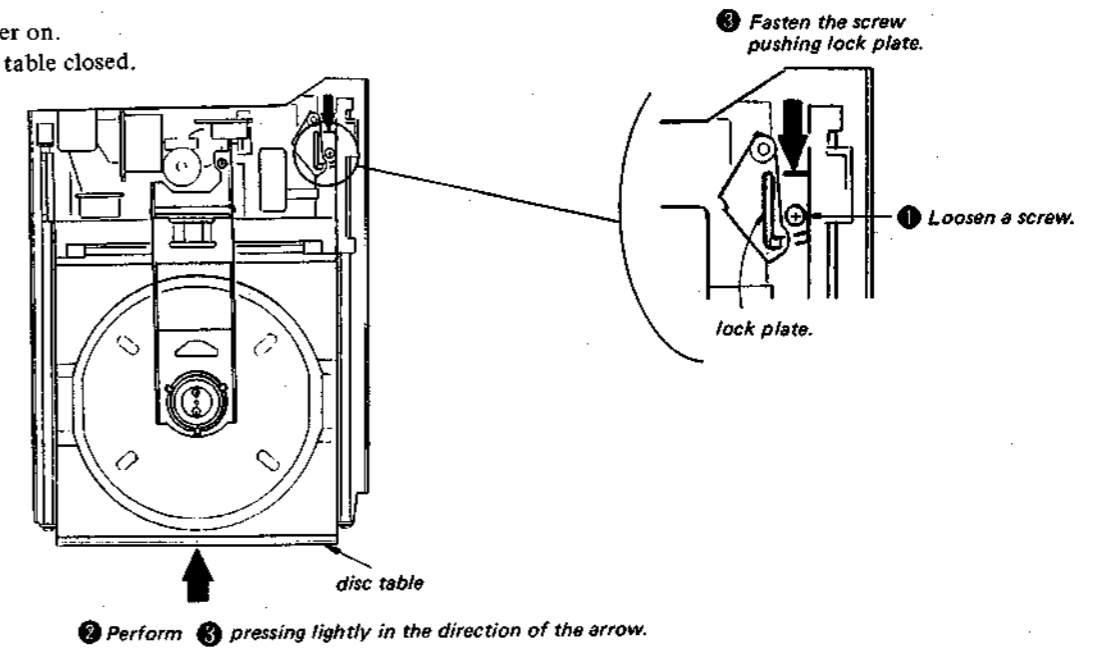

CHUCKING ARM HEIGHT ADJUSTMENT

Adjust the height of portion (A) with disc inserted and disc table closed.

Repeat loading and confirm that chucking arm does not touch disc pulley.

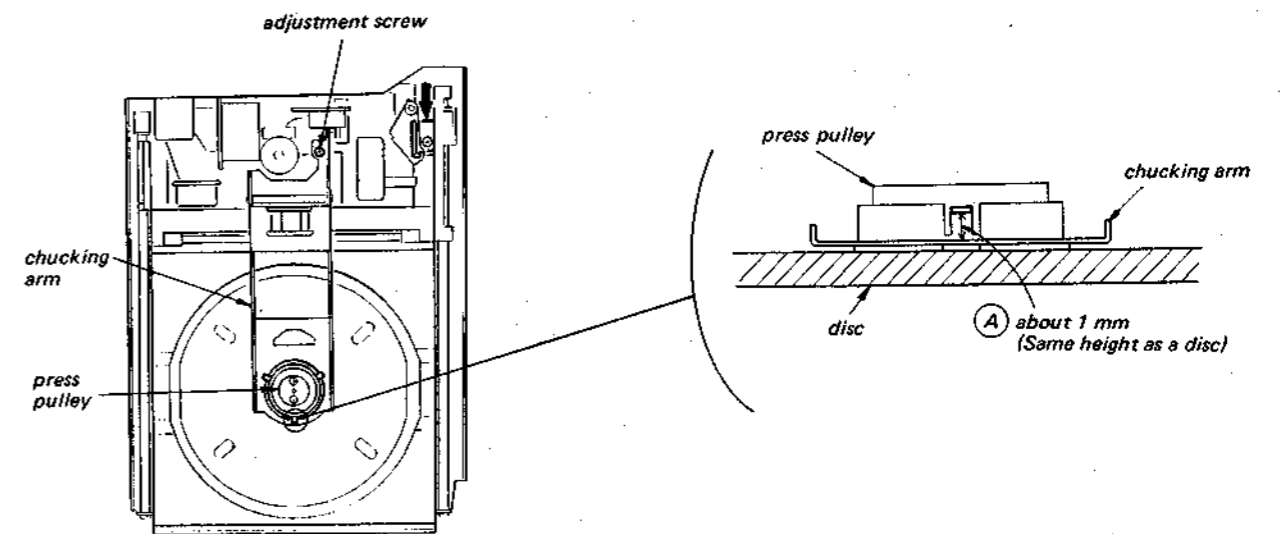

4-2. ELECTRICAL ADJUSTMENTS

1. Perform adjustments in the order given.
2. Use YEDS-1 disc unless otherwise indicated.
3. Use the oscilloscope with more than $10M\Omega$ impedance.

Adjustment Mode

1. Connect main amp board test point TP701 (TEST) and GND.

[This is to prevent the disc table from opening even though pits are not read, by making micro-computer IC701 pin (4) low.]

2. Turn POWER switch on.
(To reset micromputer.)

After adjustment, remove the lead wire connecting test points TP701 (TEST) and GND.

Adjustment Location: main board

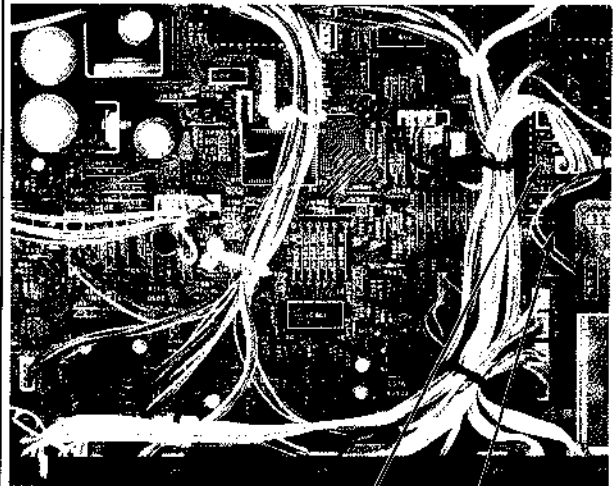

TP701 GND
TEST

Connect test points
TP701 (TEST) and GND.

RF PLL Adjustment

Procedure:

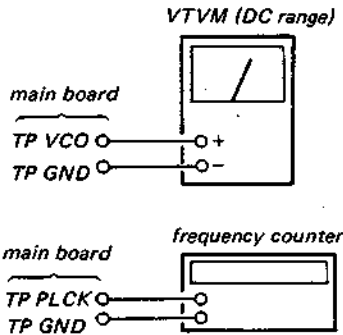

1. Turn POWER switch ON. (stop mode).
2. Keep disc table opened.
3. Put set into adjustment mode. (See page 37)
4. Connect VTVM to main board test points TP VCO and TP GND.
5. Adjust main board RV601 so that reading on VTVM is $0V \pm 50 \text{ mV}$.
6. Connect the frequency counter to main board test points TP PLCK and TP GND.
7. Adjust main board T701 so that reading on frequency counter is $4.2818 \text{ MHz} \pm 10 \text{ KHz}$.
8. Reconnect lead wires connected in adjustment mode.
9. Put disc (YEDS-1) in and press ▷ PLAY button.
10. Confirm that reading on frequency counter is 4.3218 MHz .

Adjustment Location: main board.

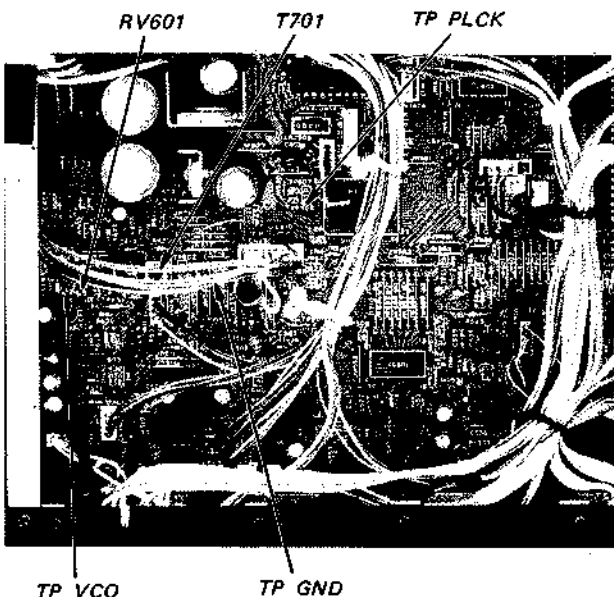

CLV Phase Lock Check

Perform this check when replacing BU-1 (base unit) and press pully in chucking arm section.)

Procedure:

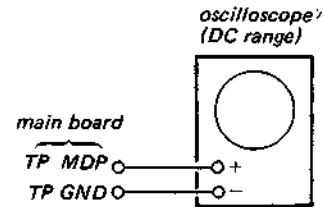

1. Put disc (YEDS-1) in.
2. Connect oscilloscope to main board test points TP MDP and TP GND.
3. Press ▷ PLAY button in TRACK 1 mode.
4. Confirm that the waveform is as shown in the figure below.

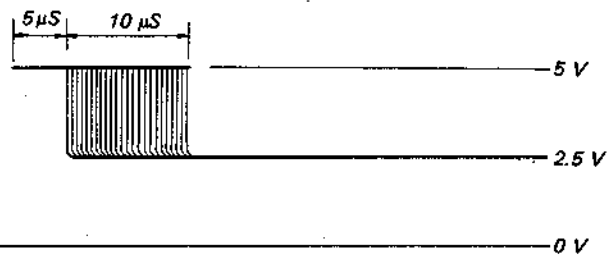

Adjustment Location: main board.

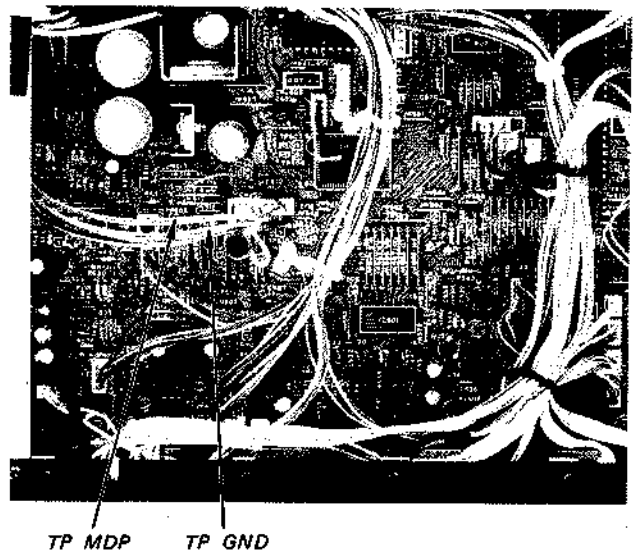

SECTION 5
DIAGRAMS

CDP-502ES/620ES CDP-502ES/620ES

5-1. MOUNTING DIAGRAM - BU-1 (BASE UNIT) SECTION -

414P 16 14 12 7 15 13 11 5 6 7 8 9 10 (Top view)	M5218L 1 8	KV1236Z cathode 2 anode 2 cathode 1 anode 1	2SA1175 2SC2785
L 1 2 3 4 5 6 7 8	CX20106 1 2 3 4 5 6 7 8	EBG3432S AA3432S anode cathode	LB1245 20 18 16 14 12 19 17 15 13 11 1 2 3 4 5 6 7 8 9 10 (Top view)
5A 1 2 3 4 5 6 7 8	LF353H 1 2 3 4 5 6 7 8	PG222SY BR2222S cathode anode	
10D-D 18D-FA P 1 2 3 4 5 6 7 8 (Top view)	UPC78M12H 1 2 3 4 5 6 7 8 (Top view)	2SK152-3 D S G	
CU04P 04P 1 2 3 4 5 6 7 8 (Top view)	NJM79M12A NJM79M05A COMMON IN OUT	2SC2001 2SB740 E C B	
53BC 1 2 3 4 5 6 7 8 (Top view)	1SS119 1 2 3 4 5 6 7 8 (Top view)	DTC143TS DTC144ES DTC114ES E C B	
2SP 1 2 3 4 5 6 7 8 (Top view)	HZ6B2L 10YD1.3 HZ5CLL RD2.7EL1 10E2 RD12EB2 10YD2.4A RD5.1EB2 RD30EB2 cathode anode	2SC2275 2SA985 B C E	
MM05A COMMON OUT	PH302B 1 2 3 4 5 6 7 8 (Top view)	2SD774-5 2SC2676 2SA1138 E C B	

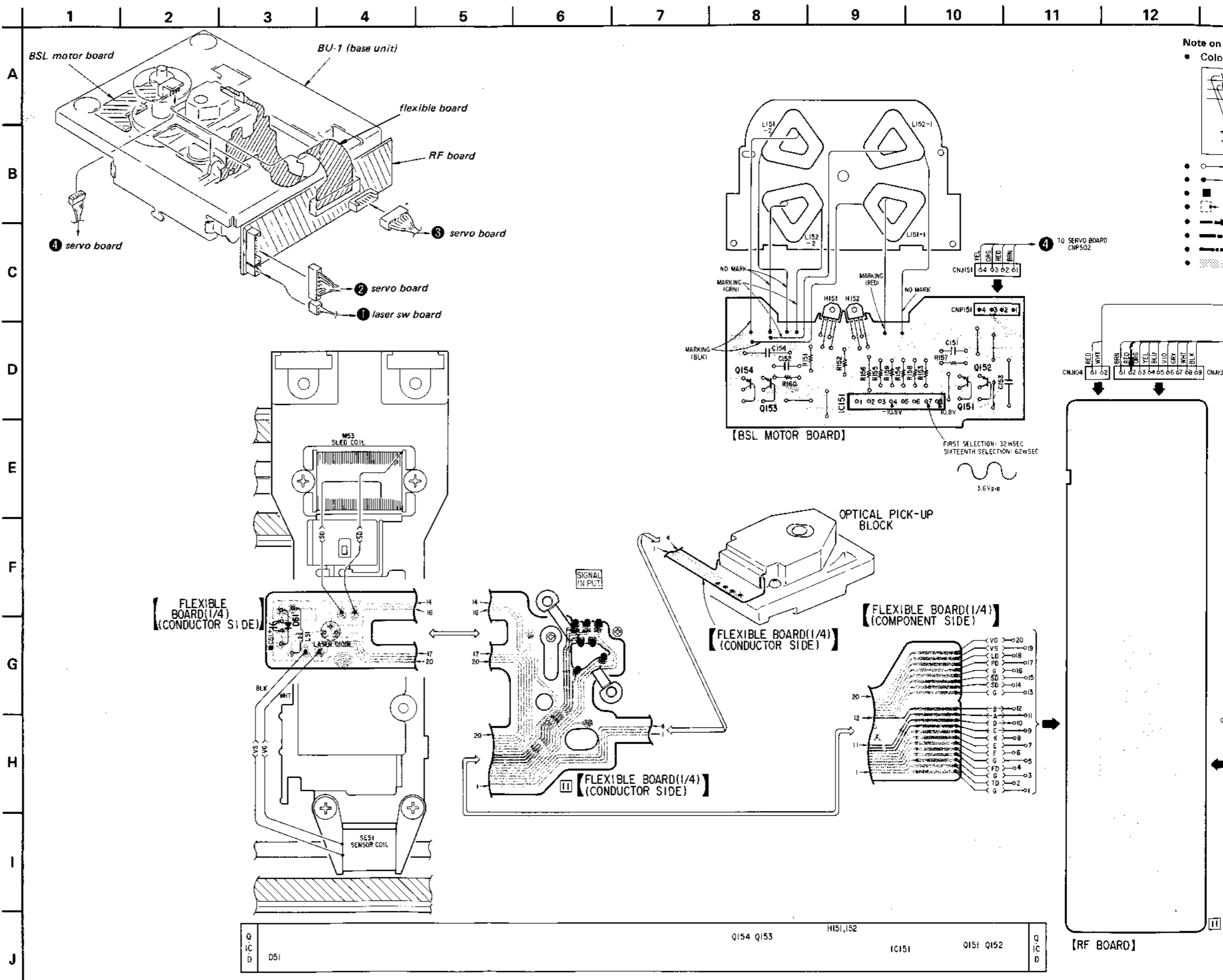

DIAGRAMS 5-1. MOUNTING DIAGRAM - BU-1 (BASE UNIT) SECTION -

2SA1175
2SC2785

LB1245

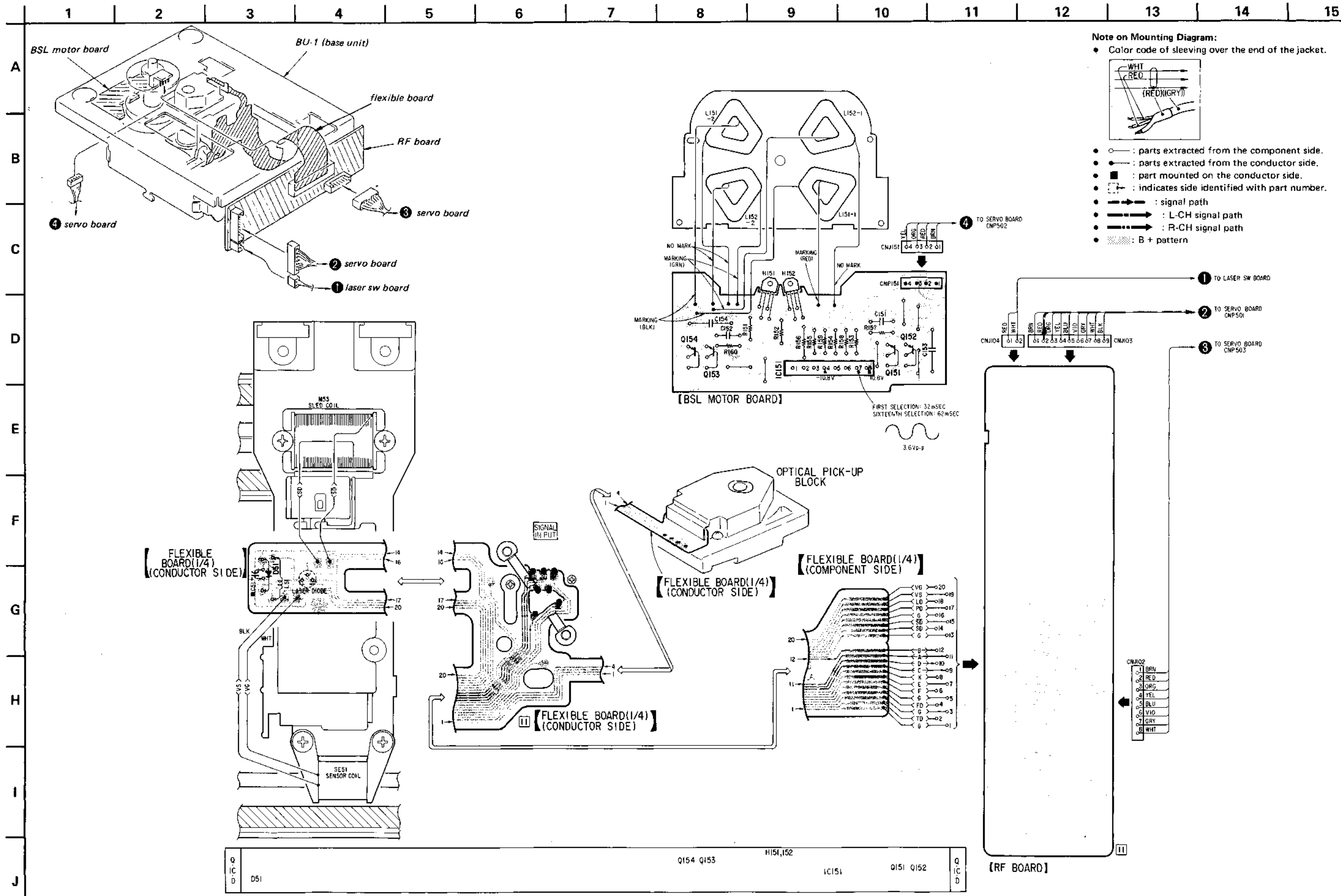
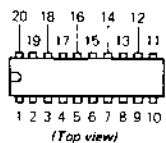

Q	D51	Q154	Q153	H151,152	IC151	Q151	Q152	Q
IC								IC
D								D

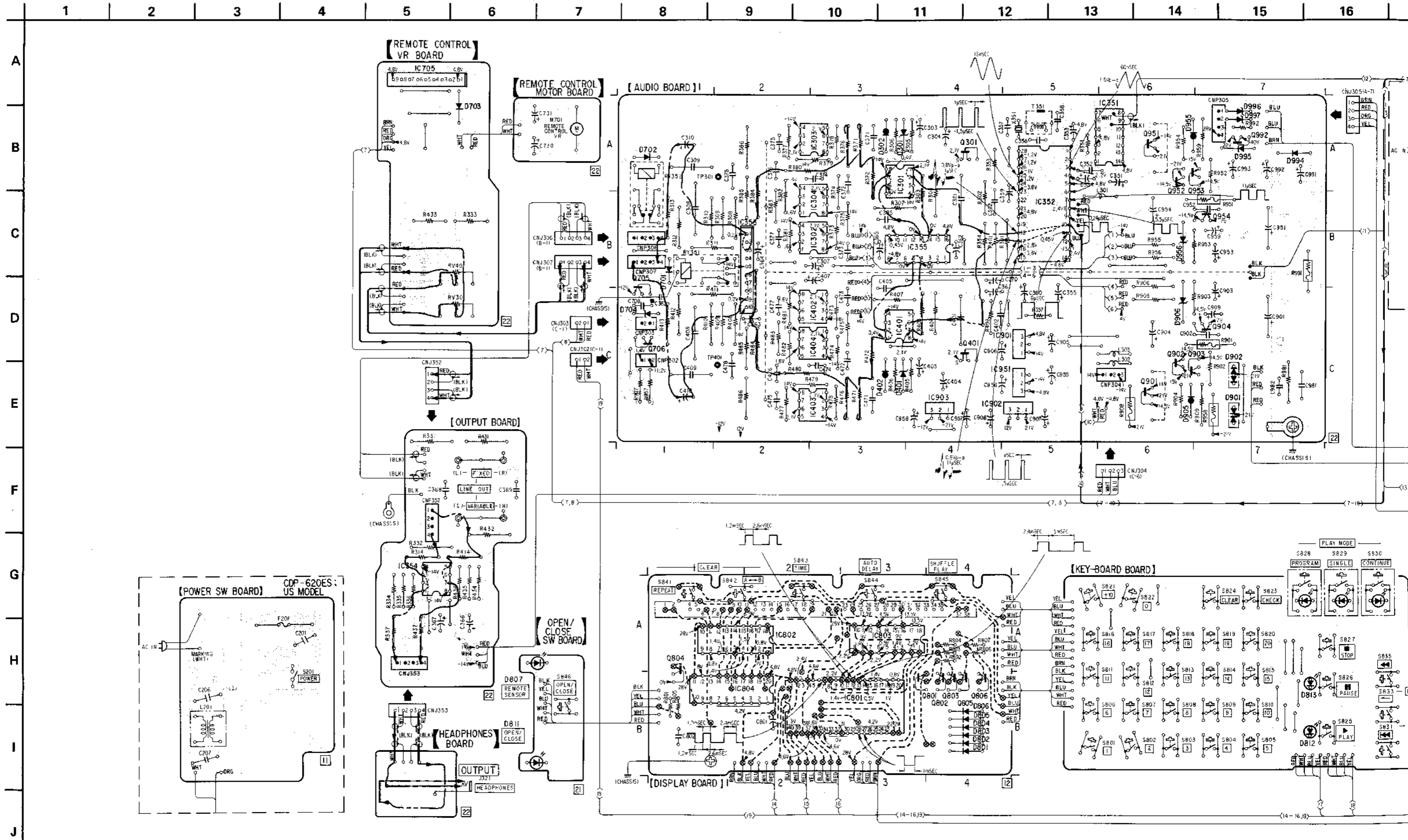

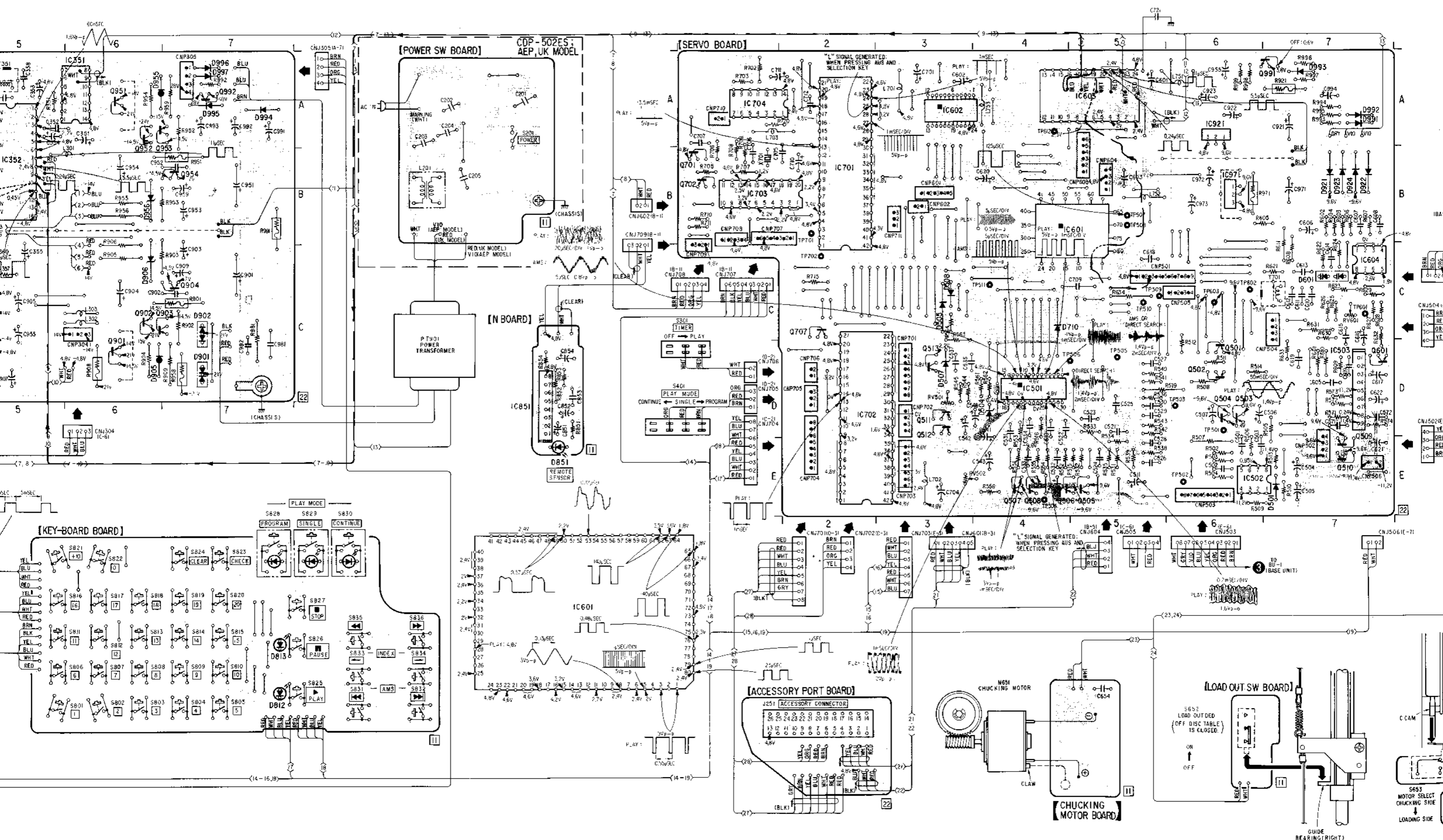

BOARD] CDP-502ES; AEP, UK MODEL

[SERVO BOARD]

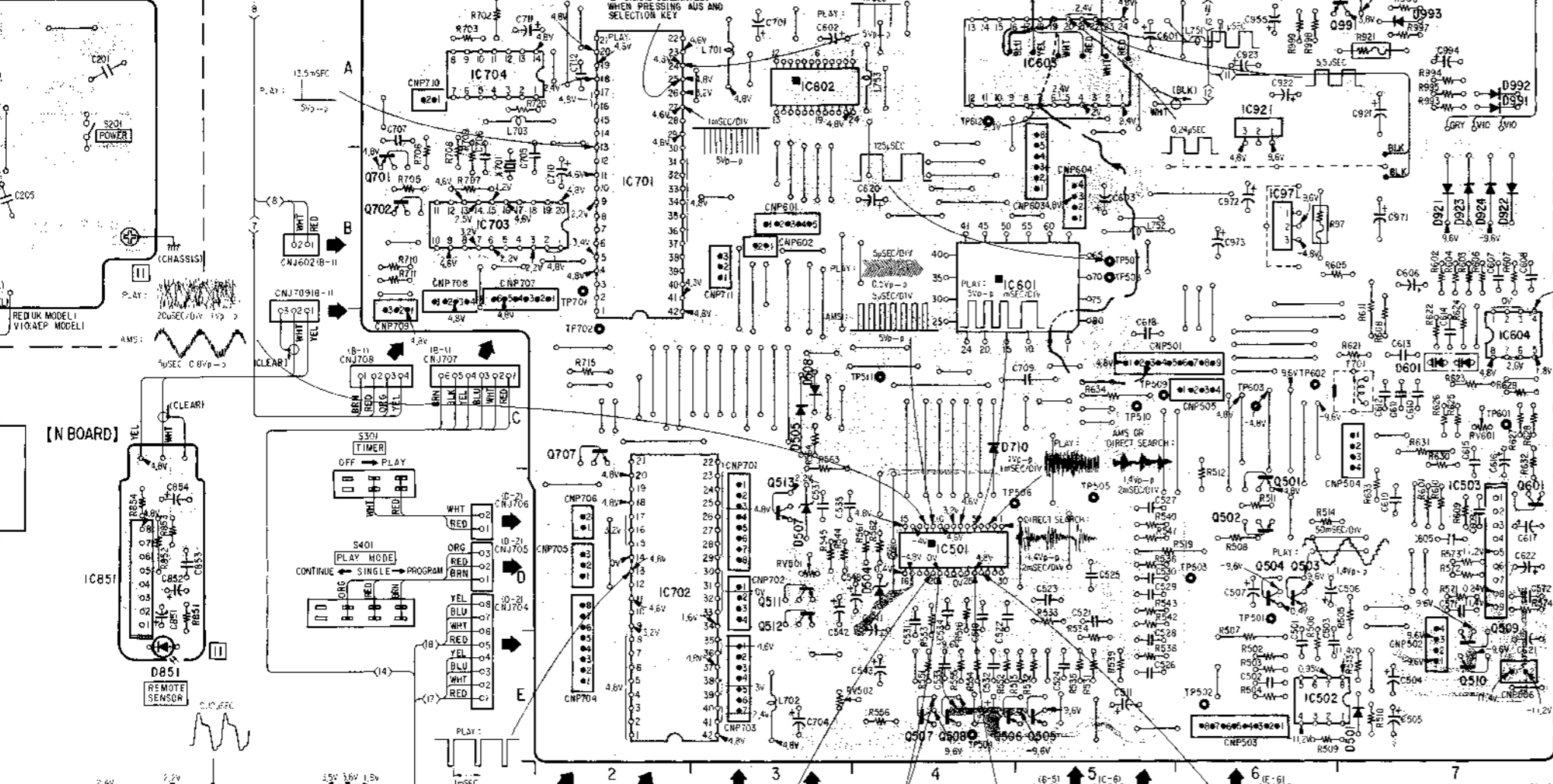

[N BOARD]

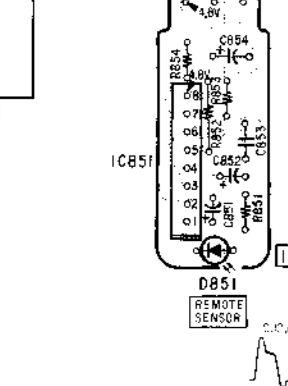

[ACCESSORY PORT BOARD]

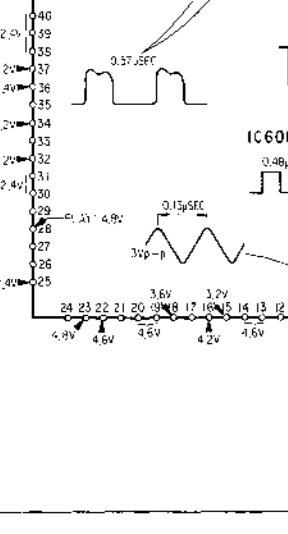

[ACCESSORY PORT BOARD]

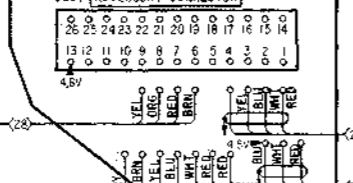

[CHUCKING MOTOR BOARD]

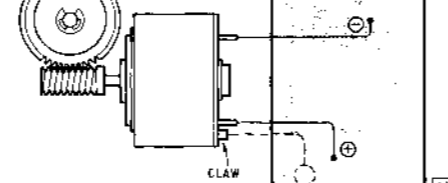

[LOAD OUT SW BOARD]

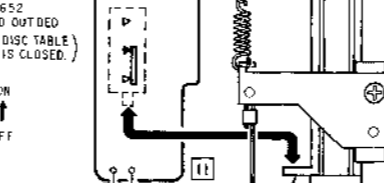

[L.C SW BOARD]

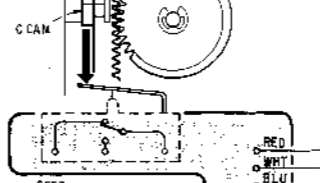

[CHUCKING SW BOARD]

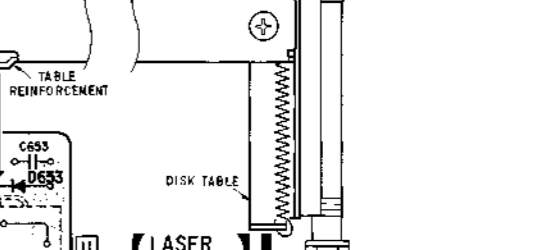

[LASER SW BOARD]

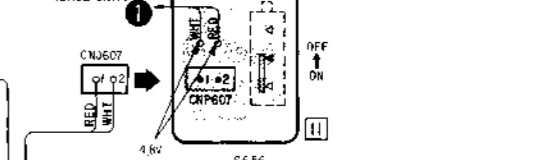

[LOAD IN SW BOARD]

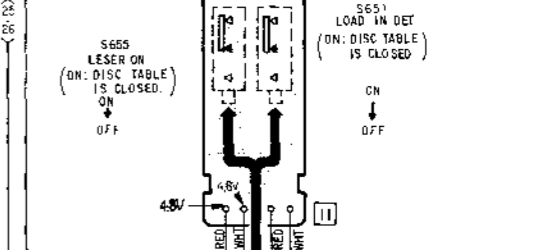

[LOADING MOTOR BOARD]

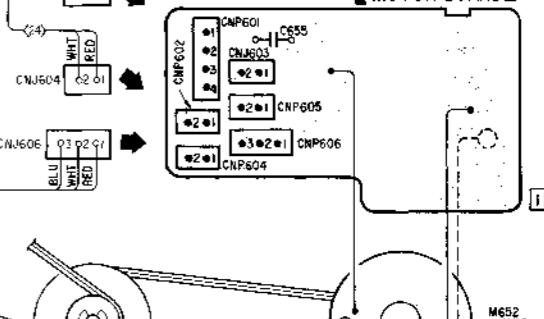

5.3. SCHEMATIC DIAGRAM - CDP502ES (AEP, UK model), CDP620ES (US model) - See page 66 for notes.

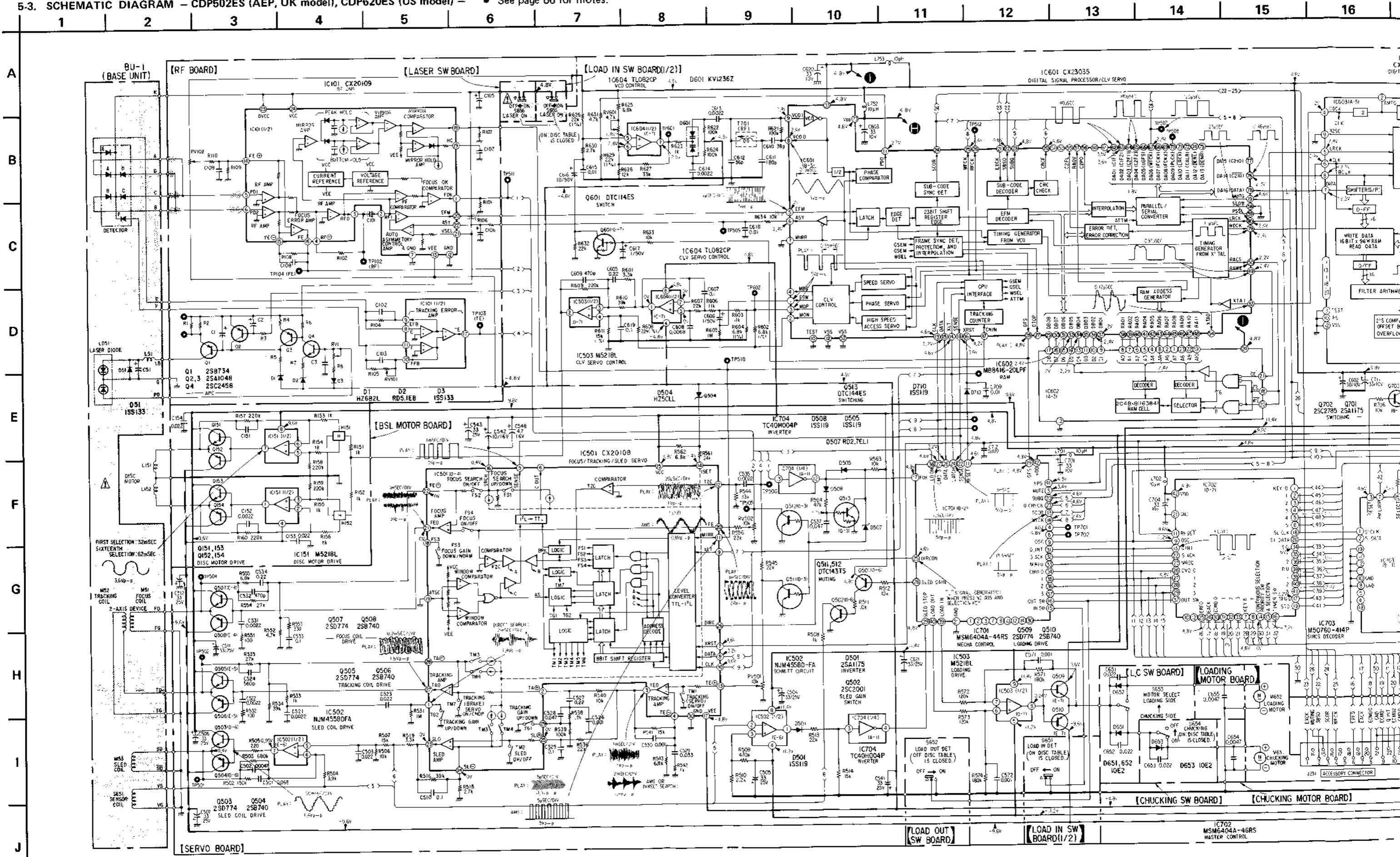

1 CX23035
DIGITAL PROCESSOR/CLV SERVO

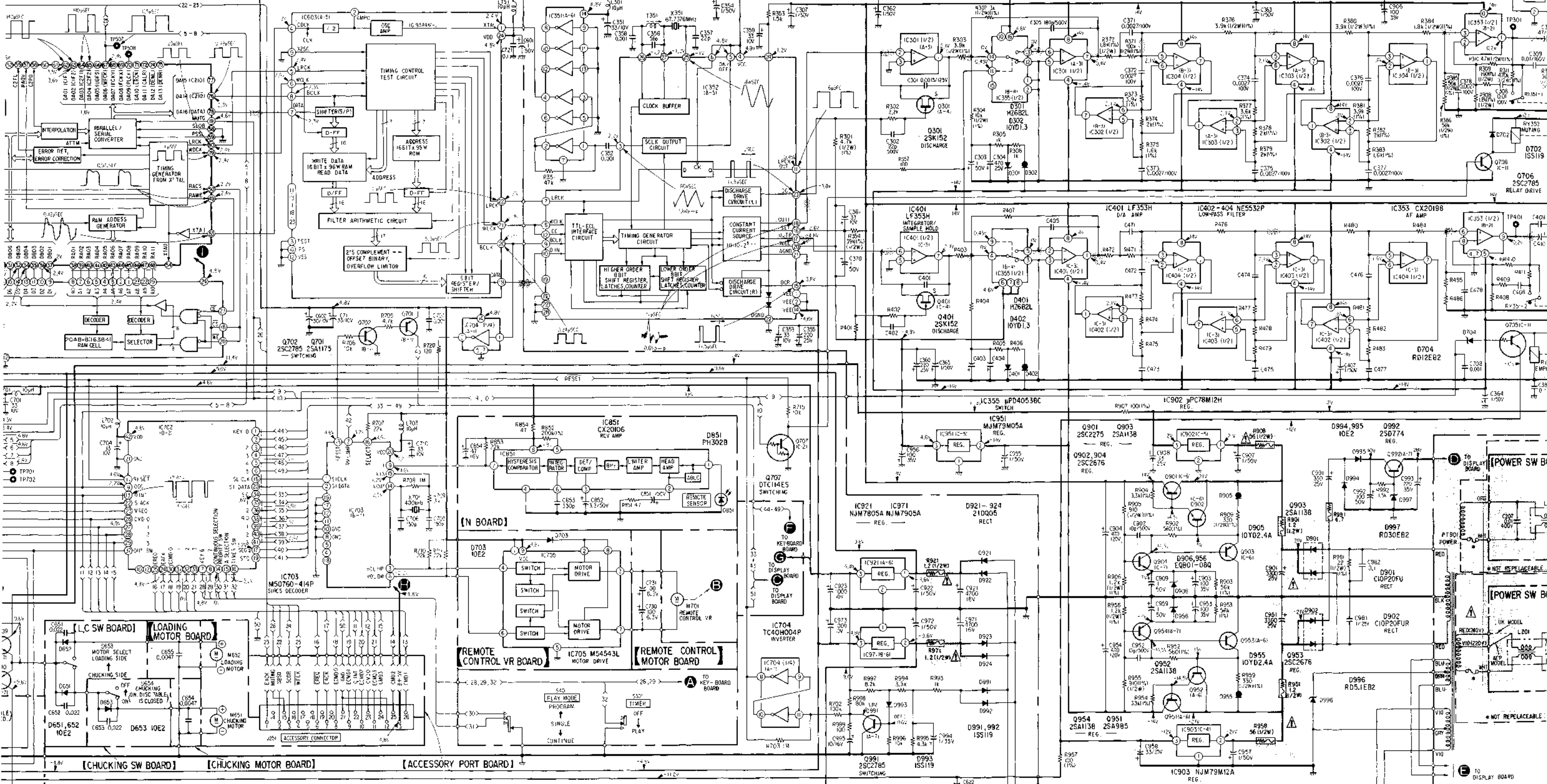

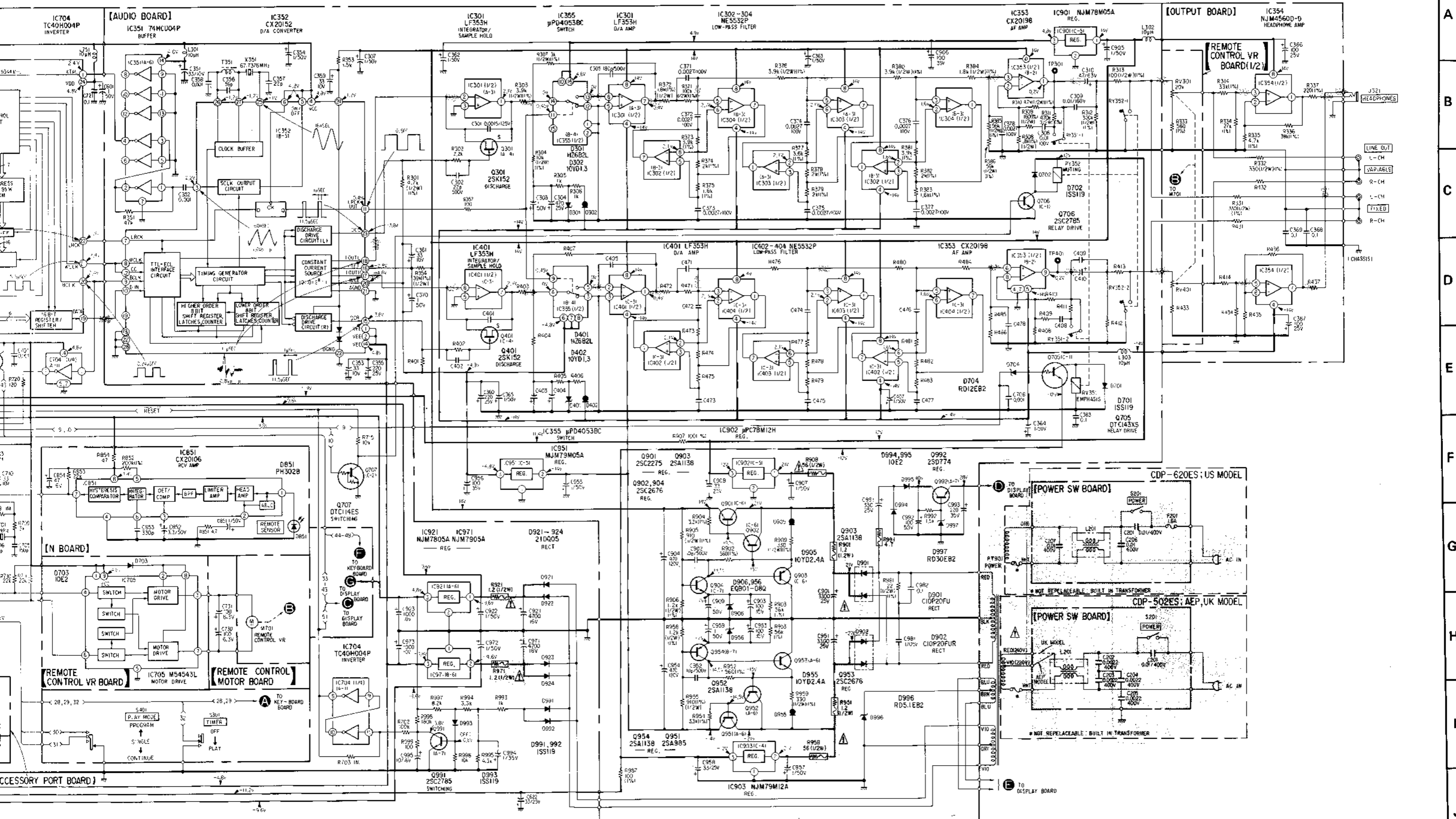

A
B
C
D
E
F
G
H
I
J

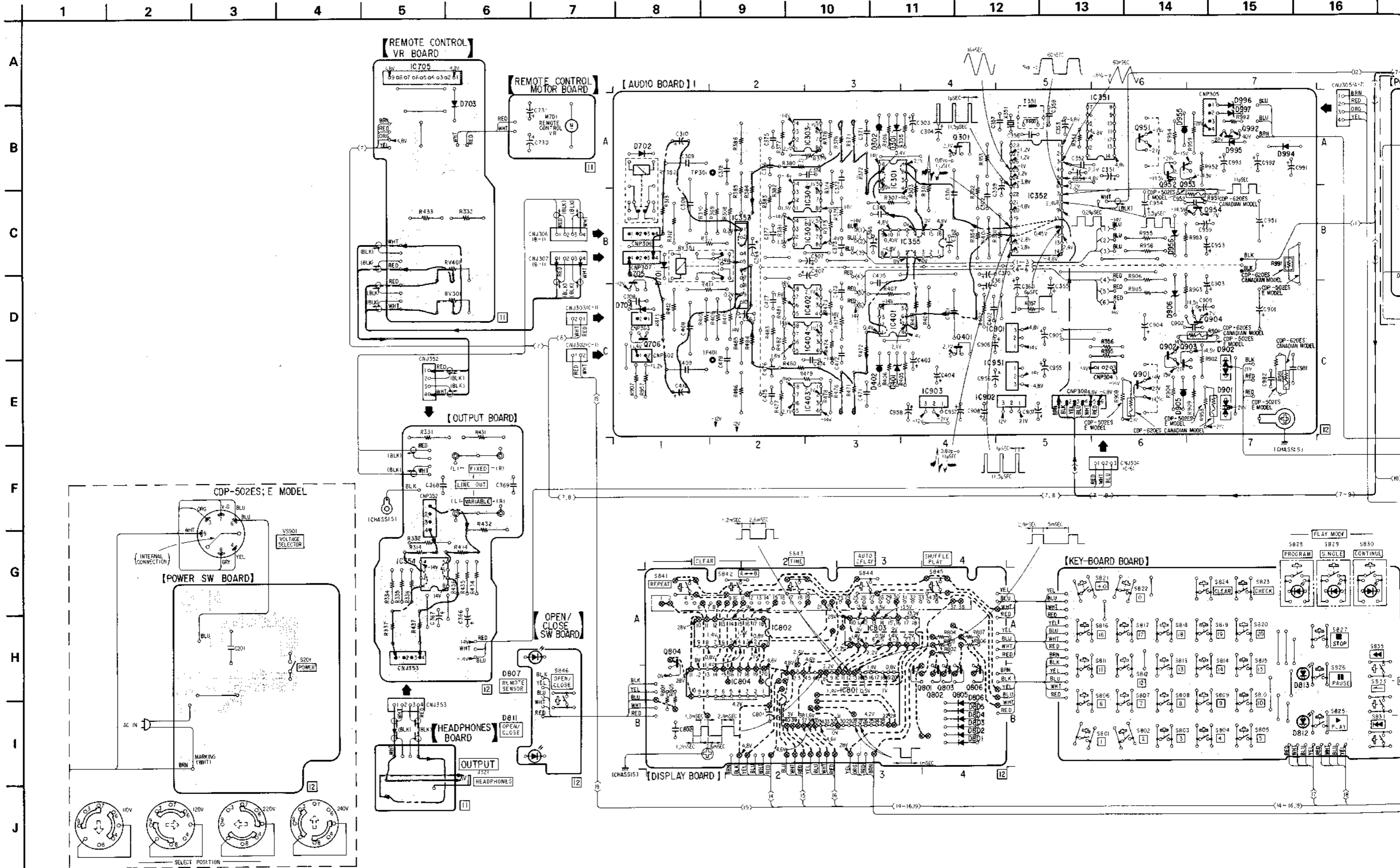

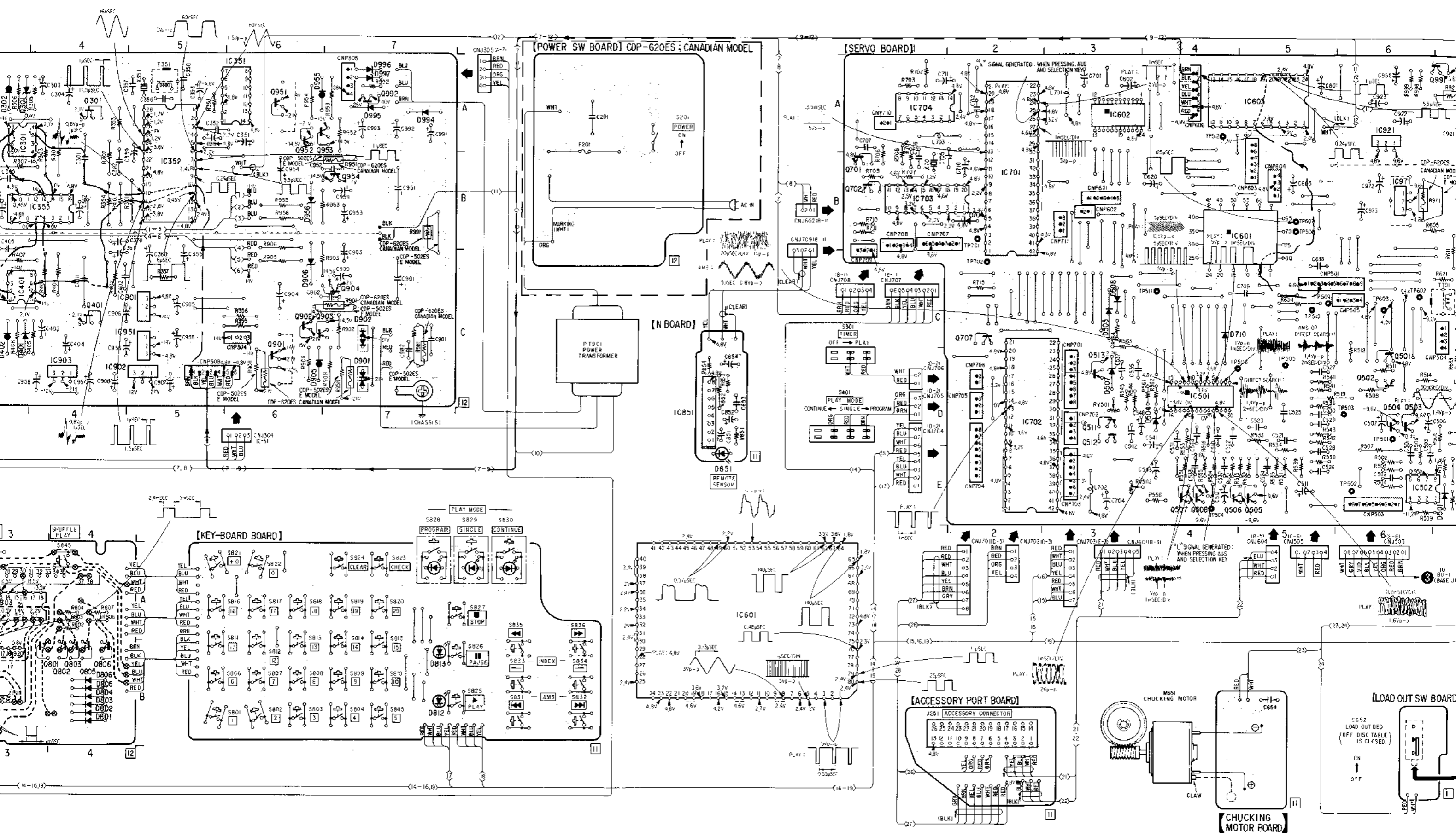

D) CDP-620ES; CANADIAN MODEL

[SERVO BOARD]

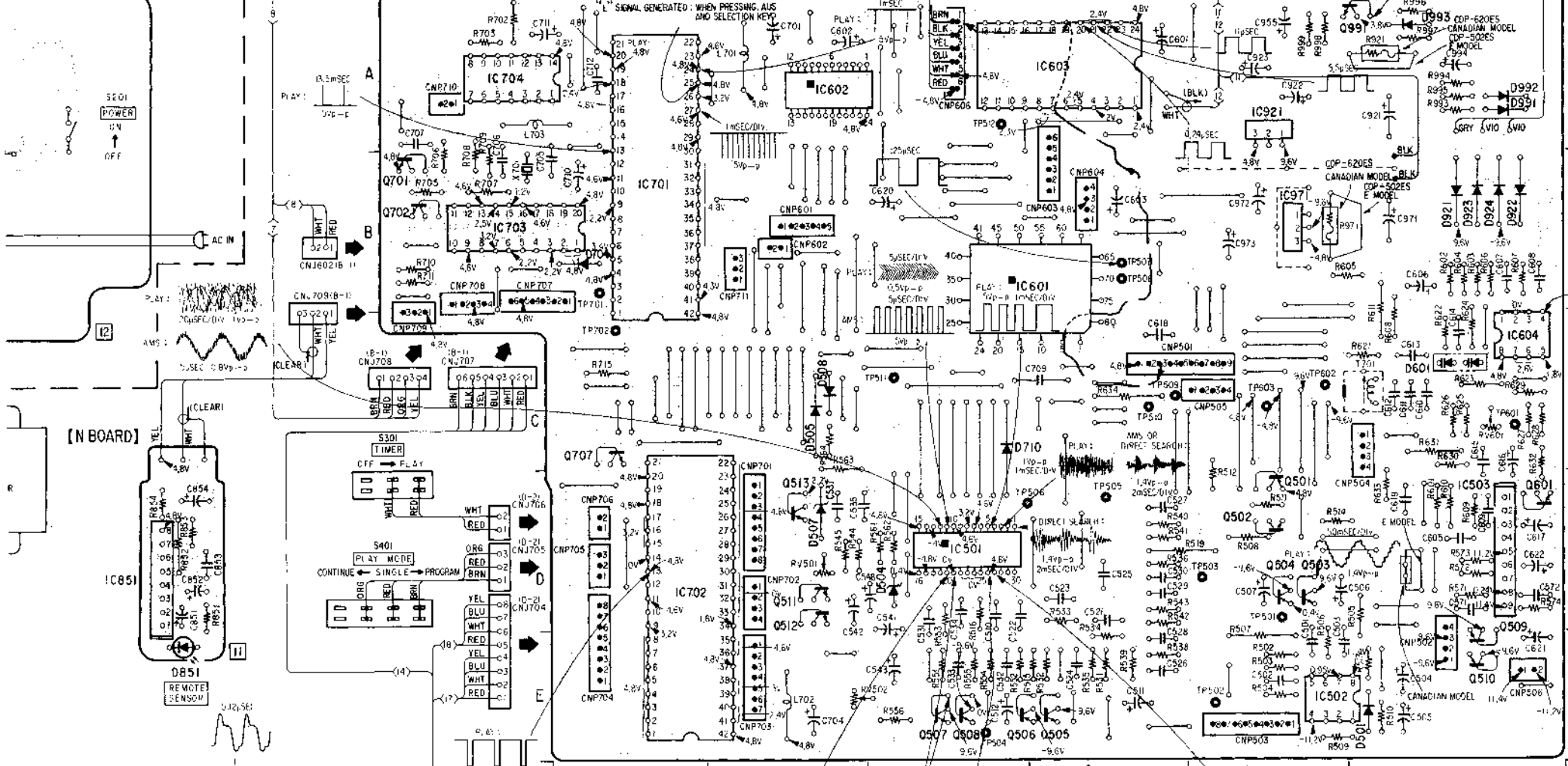

[N BOARD]

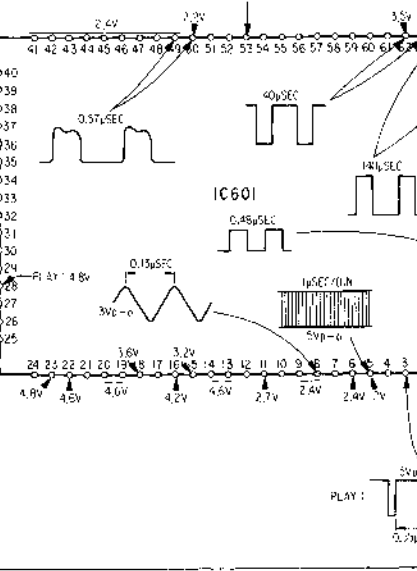
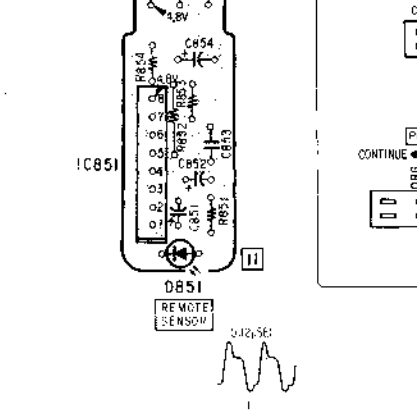

[ACCESSORY PORT BOARD]

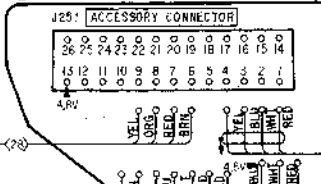

[CHUCKING MOTOR BOARD]

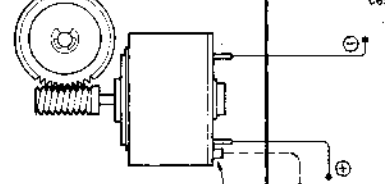

[LOAD OUT SW BOARD]

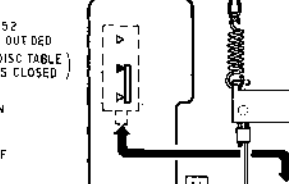

[L.C. SW BOARD]

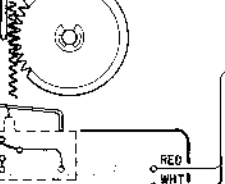

[LOADING MOTOR BOARD]

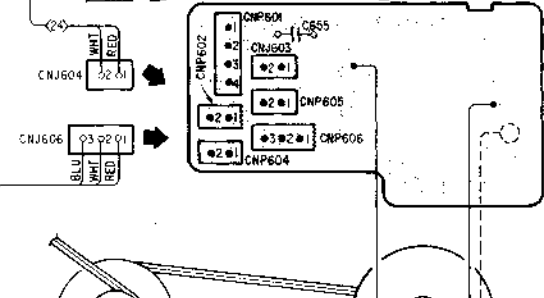

[CHUCKING SW BOARD]

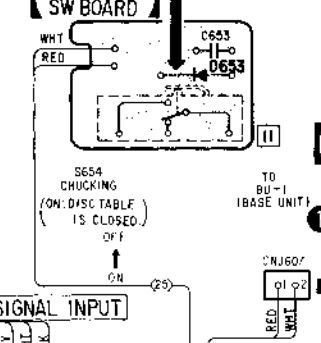

[LASER SW BOARD]

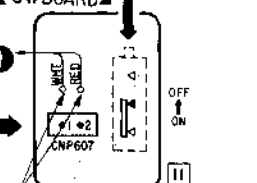

[LOAD IN SW BOARD]

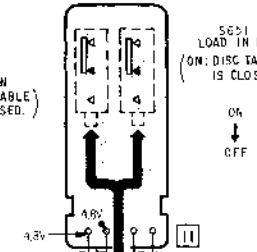

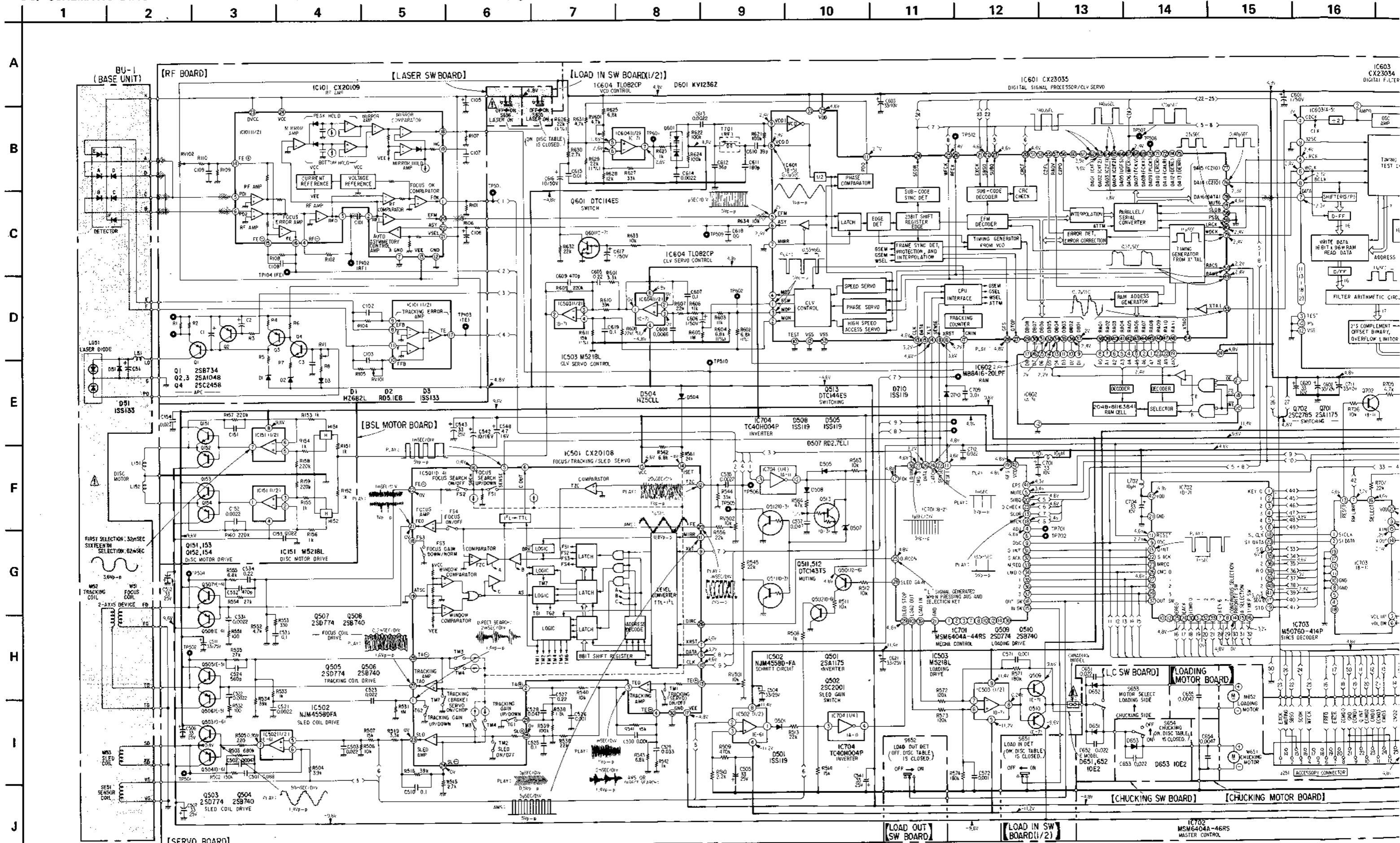

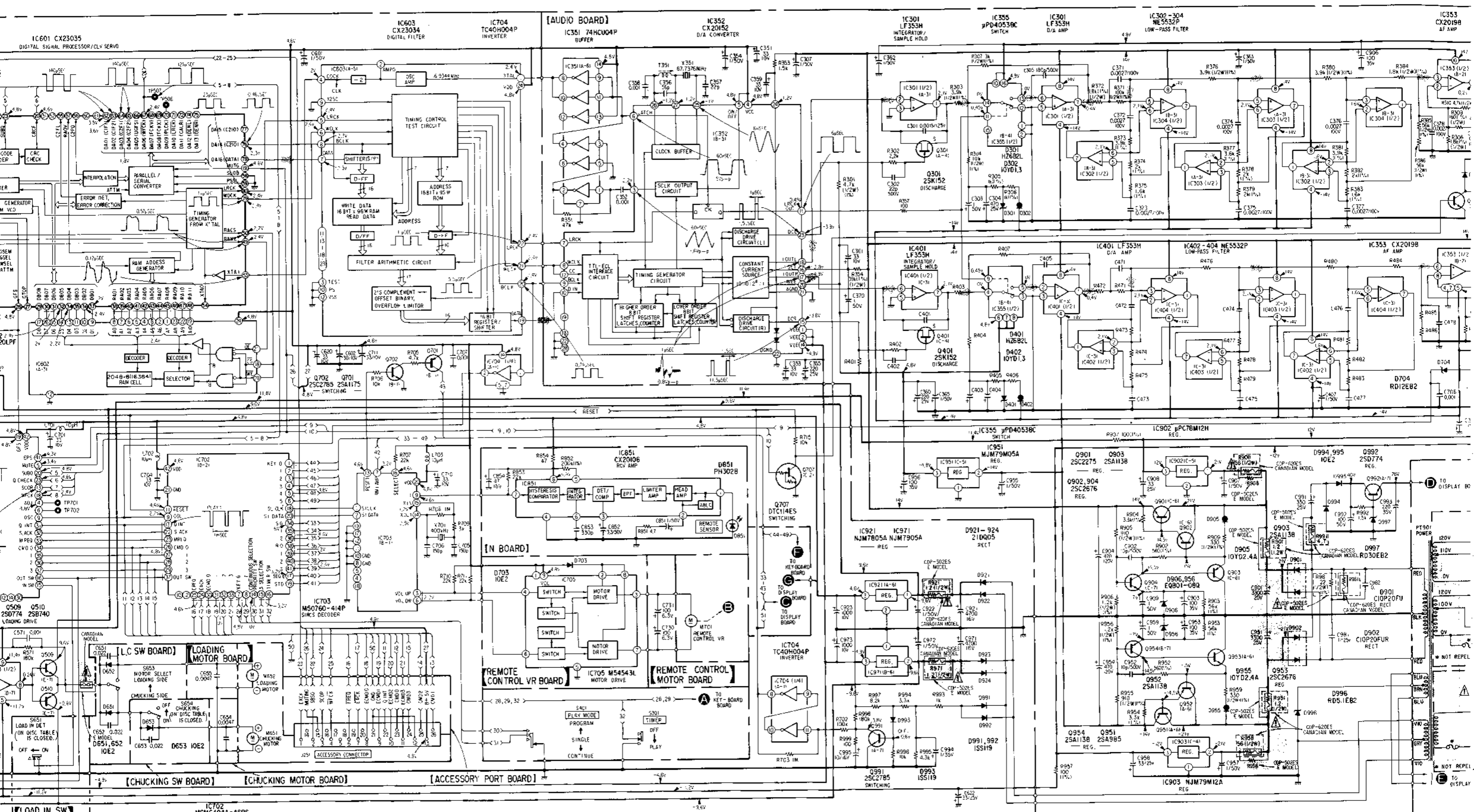

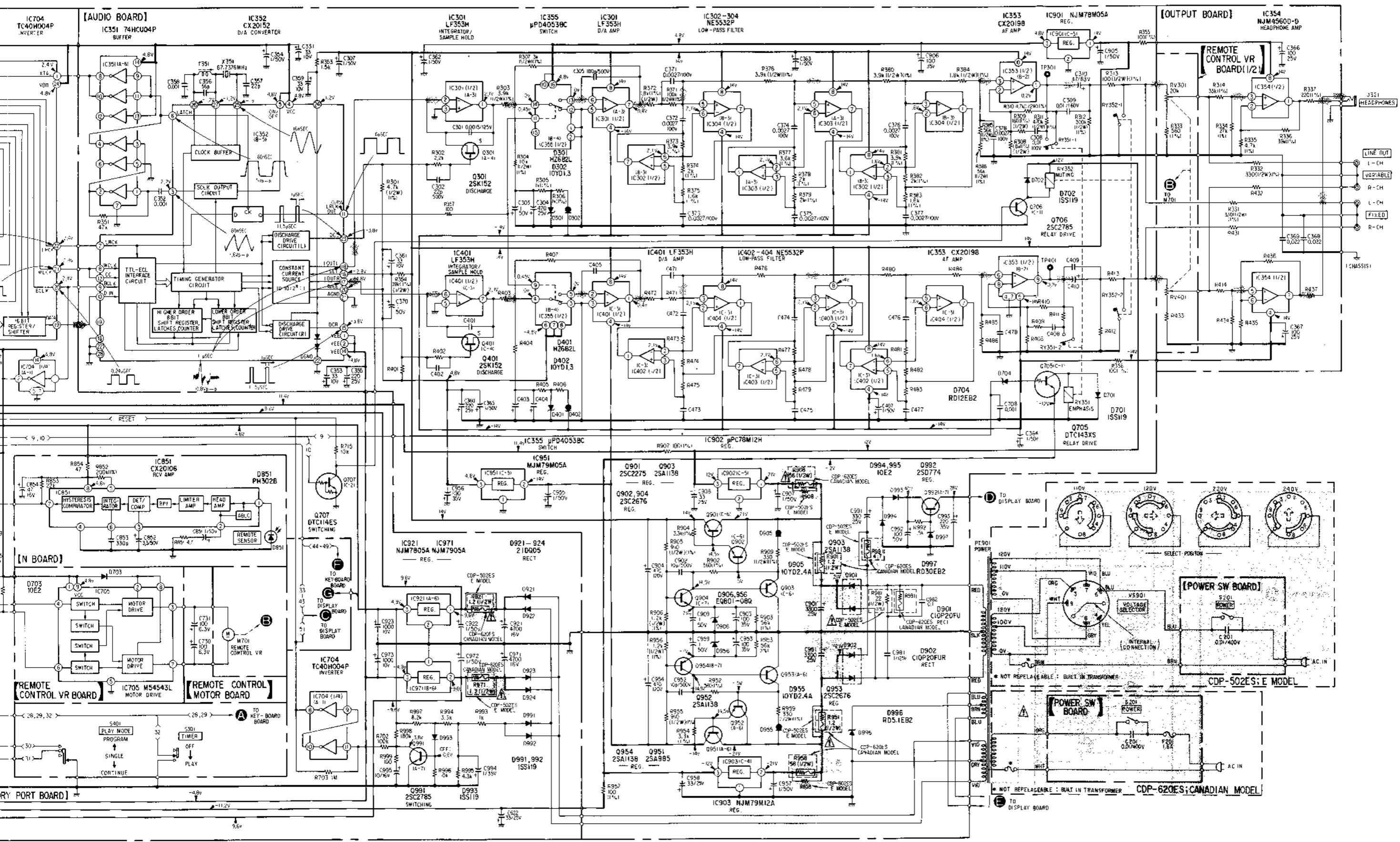

5-6. SCHEMATIC DIAGRAM - DISPLAY/KEY BOARD SECTION -

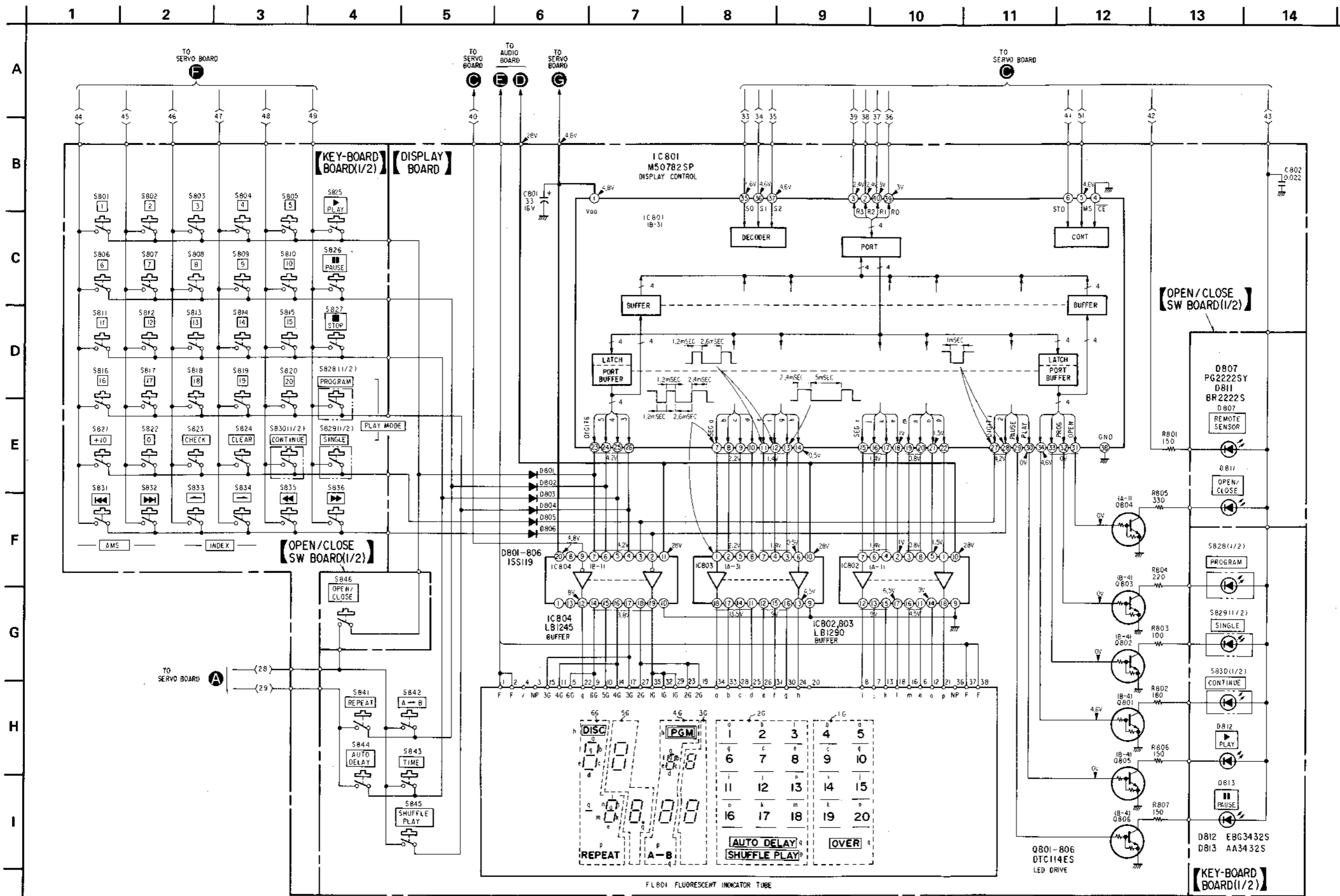

- Note on Schematic Diagram:**
- All capacitors are in μF unless otherwise specified.
 - All resistors are in Ω and $\frac{1}{4}\text{W}$ unless specified.
 - \square : signal path.
 - Components for right channel have no mark.
 - \square : nonflammable resistor.
 - --- : B+ bus.
 - --- : B- bus.
 - Readings are taken under no load with a VOM (50 $\text{k}\Omega/\text{V}$).
no mark: STOP
(): PLAY
 - Waveforms are taken to ground with an oscilloscope.
Voltage variations may be noted in the tolerance.
 - Switch

Ref. No.	Switch
S201	POWER
S301	TIMER
S401	PLAY MODE
S651	LOAD IN DET
S652	LOAD OUT DET
S653	MOTOR SWITCHING
S654	CHUCKING
S655	LASER ON (LOAD)
S656	LASER ON (LASE)
S801	(1)
S802	(2)
S803	(3)
S804	(4)
S805	(5)
S806	(6)
S807	(7)
S808	(8)
S809	(9)
S810	(10)
S811	(11)
S812	(12)
S813	(13)
S814	(14)
S815	(15)
S816	(16)
S817	(17)
S818	(18)
S819	(19)
S820	(20)
S821	(+10)
S822	(0)
S823	(CHECK)
S824	(CLEAR)
S825	(▶ PLAY)
S826	(■ PAUSE)
S827	(■ STOP)
S828	(PROGRAM)
S829	(SINGLE)
S830	(CONTINUE)
S831	(◀◀)
S832	(▶▶)
S833	(←)
S834	(→)
S835	(◀◀)
S836	(▶▶)
S841	(REPEAT)
S842	(A - B)
S843	(TIME)
S844	(AUTO DELAY)
S845	(SHUFFLE PLAY)
S846	(OPEN/CLOSE)

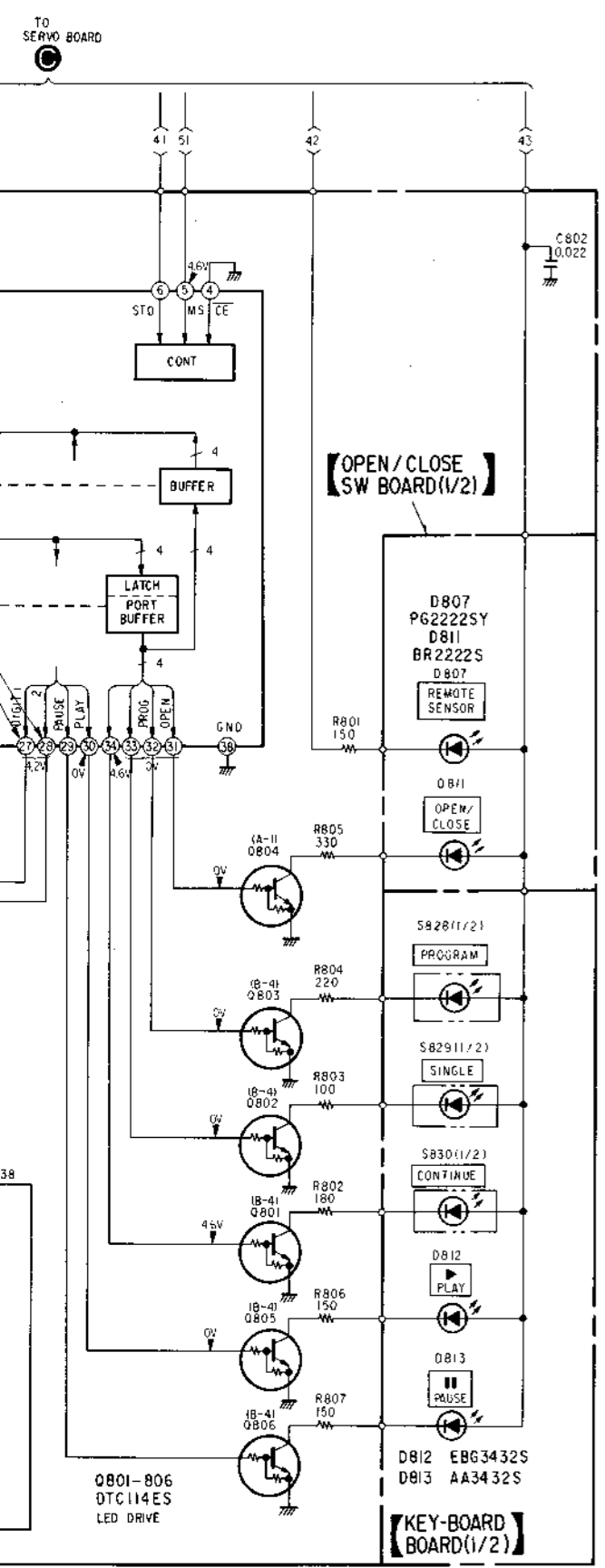

Note on Schematic Diagram:

- All capacitors are in μF unless otherwise noted. pF : μF 50WV or less are not indicated except for electrolytics and tantalums.
- All resistors are in Ω and $1/4\text{W}$ or less unless otherwise specified.
- : signal path.
- Components for right channel have same values as for left channel.
- : nonflammable resistor.
- : B+ bus.
- - -: B- bus.
- Readings are taken under no-signal conditions with a VOM (50 k Ω /V). no mark: STOP (): PLAY
- Waveforms are taken to ground in play mode by using oscilloscope. Voltage variations may be noted due to normal production tolerances.
- Switch

Ref. No.	Switch	Position
S201	POWER	OFF
S301	TIMER	OFF
S401	PLAY MODE	OFF
S651	LOAD IN DET	OFF
S652	LOAD OUT DET	OFF
S653	MOTOR SWITCHING	OFF
S654	CHUCKING	OFF
S655	LASER ON (LOADING SIDE)	OFF
S656	LASER ON (LASER SIDE)	OFF
S801	(1)	OFF
S802	(2)	OFF
S803	(3)	OFF
S804	(4)	OFF
S805	(5)	OFF
S806	(6)	OFF
S807	(7)	OFF
S808	(8)	OFF
S809	(9)	OFF
S810	(10)	OFF
S811	(11)	OFF
S812	(12)	OFF
S813	(13)	OFF
S814	(14)	OFF
S815	(15)	OFF
S816	(16)	OFF
S817	(17)	OFF
S818	(18)	OFF
S819	(19)	OFF
S820	(20)	OFF
S821	(+10)	OFF
S822	(0)	OFF
S823	(CHECK)	OFF
S824	(CLEAR)	OFF
S825	(▶ PLAY)	OFF
S826	(■ PAUSE)	OFF
S827	(■ STOP)	OFF
S828	(PROGRAM)	OFF
S829	(SINGLE)	OFF
S830	(CONTINUE)	OFF
S831	(◀◀)	OFF
S832	(▶▶)	OFF
S833	(←)	OFF
S834	(→)	OFF
S835	(◀)	OFF
S836	(▶)	OFF
S841	(REPEAT)	OFF
S842	(A - B)	OFF
S843	(TIME)	OFF
S844	(AUTO DELAY)	OFF
S845	(SHUFFLE PLAY)	OFF
S846	(OPEN/CLOSE)	OFF

EXPLODED VIEWS AND PARTS LIST

NOTE:

- The mechanical parts with no reference number in the exploded views are not supplied.
- Items marked " * " are not stocked since they are seldom required for routine service. Some delay should be anticipated when ordering these items.
- The construction parts of an assembled part are indicated with a collation number in the remark column.

The components identified by shading and mark A are critical for safety. Replace only with part number specified.

Les composants identifiés par une trame et une marque A sont critiques pour la sécurité. Ne les remplacer que par une pièce portant le numéro spécifié.

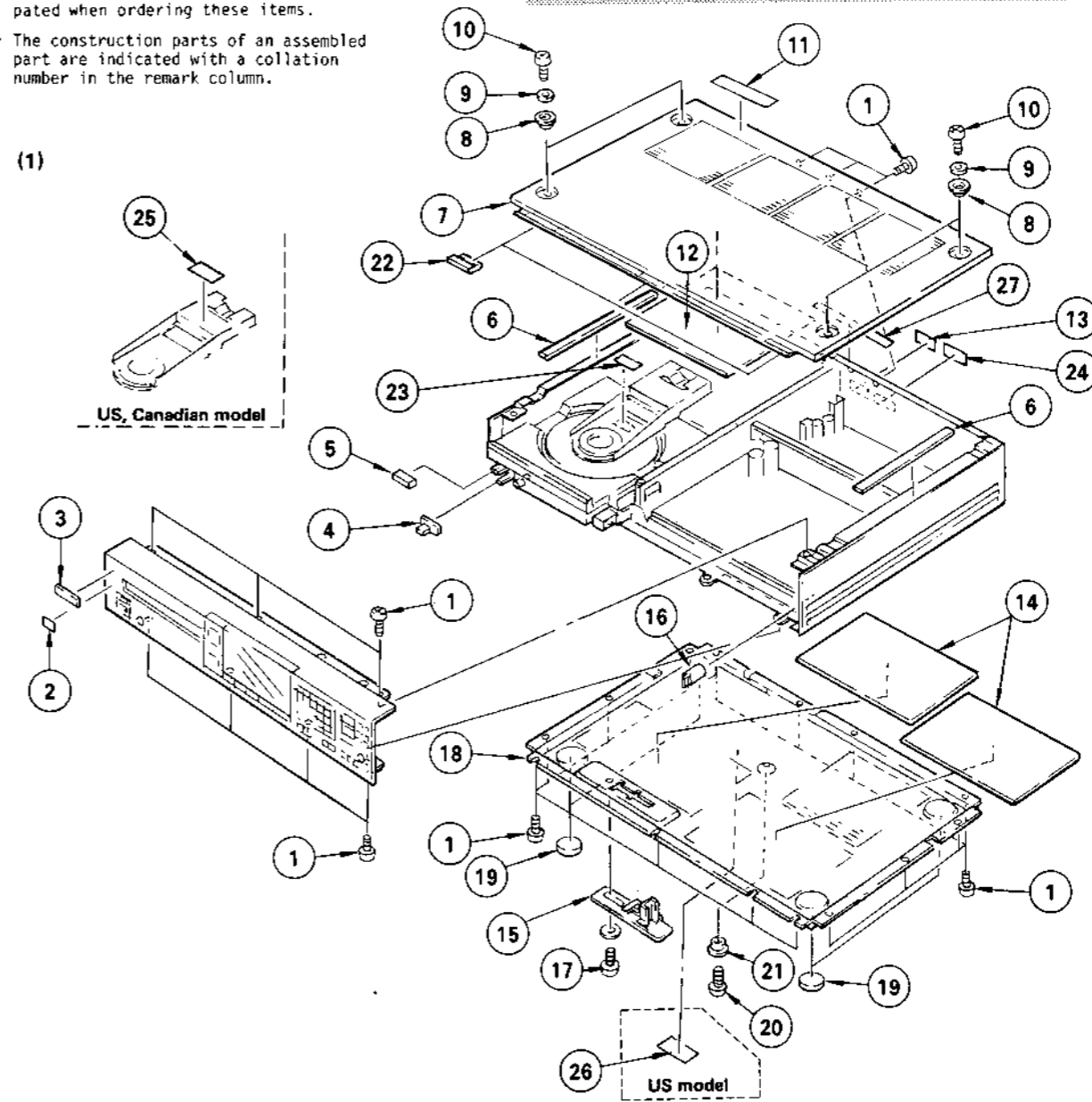

No.	Part No.	Description	Remarks	No.	Part No.	Description	Remarks
1	3-703-685-31	SCREW (+BV 3X8)		14	*4-908-960-01	SHEET, PS	
2	3-703-710-41	STICKER, SONY SYMBOL (12)		15	*4-908-600-01	LEVER, LOCK, TRANSPORT	
3	3-304-974-01	EMBLEM, SONY		16	4-908-908-01	KNOB, CONTROL	
4	4-887-131-00	KNOB, SLIDE SWITCH		17	3-323-470-01	SCREW (B3X6), (+ -)	4-886-538-31
5	X-4887-104-0	KNOB ASSY, POWER		18	4-908-948-01	(Canadian,E)...PLATE, BOTTOM	59 *4-908-958-01
6	3-831-441-11	(Canadian,E)...SPACER (10X16X0.5)		19	4-908-948-11	(US,AEP,UK)...PLATE, BOTTOM	60 3-703-685-31
7	4-886-578-01	(AEP,UK,US)...SPACER (A), CONDUCTIVE		19	4-908-922-01	FOOT	61 *4-908-915-01
7	4-908-925-01	(Canadian,E)...PLATE, TOP		20	7-687-510-31	(Canadian,E)...SCREW (+BYTT M3S)	62 *4-902-345-01
7	4-908-925-11	(US,AEP,UK)...PLATE, TOP		20	3-703-685-31	(US,AEP,UK)...SCREW +BV 3X8	63 *4-879-920-00
8	3-576-298-11	ESCUTCHEON		21	2-371-561-00	(E,Canadian)...BUSHING (P), INSULATING	64 2-259-121-00
9	7-688-003-12	W 3, MIDDLE		22	3-831-441-11	SHEET, PROTECTION	65 7-685-873-01
10	7-682-547-09	SCREW +B 3X6		23	4-908-404-01	LABEL, APARTURE, LASER, DHHS	66 *4-886-555-00
11	4-885-831-00	LABEL, CAUTION		24	*4-885-838-00	LABEL, CLASS 1	67 4-870-272-00
12	*4-908-959-01	DAMPER (B)		25	3-323-294-01	(US,Canadian)...LABEL, DHHS INTERLOCK	68 4-887-707-00
13	4-908-980-01	(AEP)...LABEL, MODEL NUMBER		26	3-703-680-00	LABEL, CAUTION, SUB, NEW UL (US)	
	4-908-981-01	(G-AEP)...LABEL, MODEL NUMBER					
	4-908-982-01	(UK)...LABEL, MODEL NUMBER					
	4-908-464-01	(Canadian,US)...LABEL, MODEL NUMBER					
	*4-908-979-01	(E)...LABEL, MODEL NUMBER					

SECTION 6

CDP-502ES/620ES CDP-502ES/620ES

EXPLODED VIEWS AND PARTS LIST

NOTE:
 • The mechanical parts with no reference number in the exploded views are not supplied.
 • Items marked "★" are not stocked since they are seldom required for routine service. Some delay should be anticipated when ordering these items.
 • The construction parts of an assembled part are indicated with a collation number in the remark column.

The components identified by shading and mark Δ are critical for safety. Replace only with part number specified.
 Les composants identifiés par une trame et une marque Δ sont critiques pour la sécurité. Ne les remplacer que par une pièce portant le numéro spécifié.

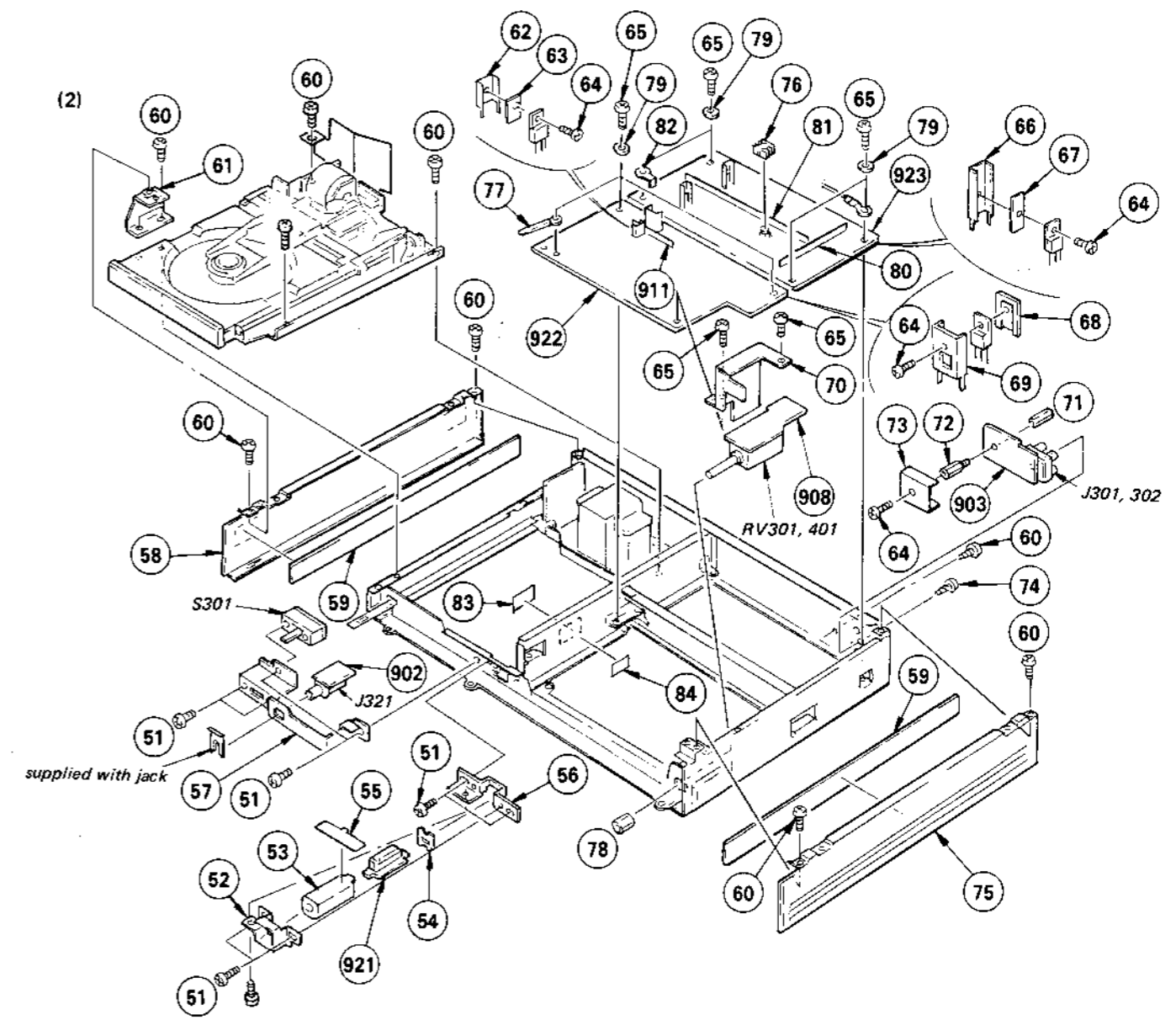
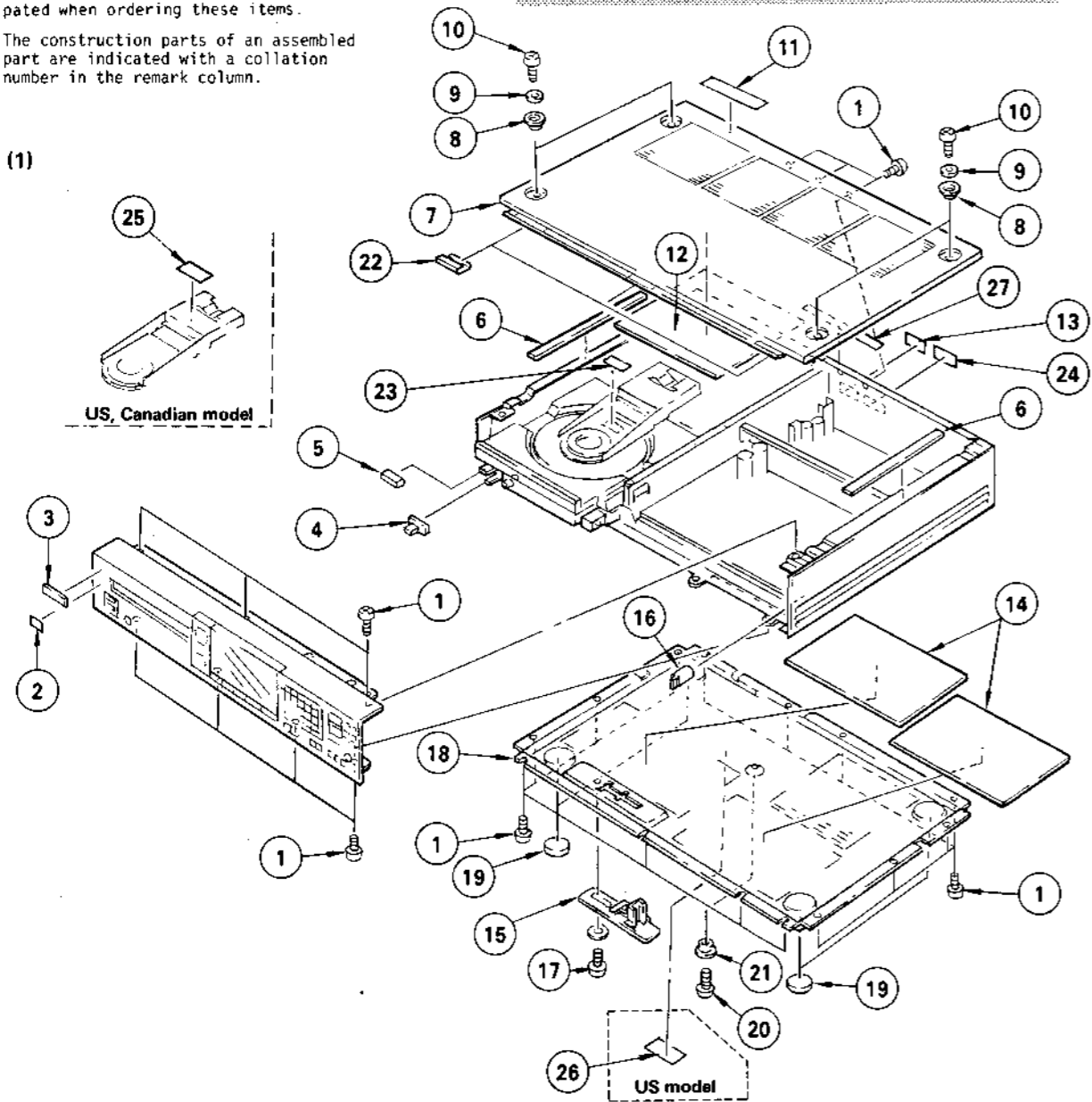

No.	Part No.	Description	Remarks	No.	Part No.	Description	Remarks
1	3-703-685-31	SCREW (+BV 3X8)		14	*4-908-960-01	SHEET, P5	
2	3-703-710-41	STICKER, SONY SYMBOL (12)		15	*4-908-600-01	LEVER, LOCK, TRANSPORT	
3	3-304-974-01	EMBLEM, SONY		16	4-908-908-01	KNOB, CONTROL	
4	4-887-131-00	KNOB, SLIDE SWITCH		17	3-323-470-01	SCREW (B3X6), (+ -)	
5	X-4887-104-0	KNOB ASSY, POWER		18	4-908-948-01	(Canadian,E)...PLATE, BOTTOM	
6	3-831-441-11	(Canadian,E)...SPACER (10X16X0.5)		19	4-908-948-11	(US,AEP,UK)...PLATE, BOTTOM	
7	4-886-578-01	(AEP,UK,US)...SPACER (A), CONDUCTIVE		20	4-908-922-01	FOOT	
8	4-908-925-01	(Canadian,E)...PLATE, TOP		21	7-687-510-31	(Canadian,E)...SCREW (+BVTT M3S)	
9	4-908-925-11	(US,AEP,UK)...PLATE, TOP		22	3-703-685-31	(US,AEP,UK)...SCREW +BV 3X8	
10	3-576-298-11	ESCUTCHEON		23	2-371-561-00	(E,Canadian)...BUSHING (P), INSULATING	
11	7-688-003-12	W 3, MIDDLE		24	3-831-441-11	SHEET, PROTECTION	
12	7-682-547-09	SCREW +B 3X6		25	4-908-404-01	LABEL, APARTURE, LASER, DHHS	
13	4-885-831-00	LABEL, CAUTION		26	*4-885-838-00	LABEL, CLASS 1	
14	*4-908-959-01	DAMPER (B)		25	3-323-294-01	(US,Canadian)...LABEL, DHHS INTERLOCK	
15	4-908-980-01	(AEP).....LABEL, MODEL NUMBER		26	3-703-680-00	LABEL, CAUTION, SUB, NEW UL (US)	
16	4-908-981-01	(G-AEP).....LABEL, MODEL NUMBER					
17	4-908-982-01	(UK).....LABEL, MODEL NUMBER					
18	4-908-464-01	(Canadian,US)...LABEL, MODEL NUMBER					
19	*4-908-979-01	(E).....LABEL, MODEL NUMBER					

No.	Part No.	Description	Remarks	No.	Part No.	Description	Remarks
51	7-685-871-01	SCREW +BVTT 3X6 (S)		69	*4-908-954-01	HEAT SINK, TR	
52	*4-908-930-01	BRACKET (B), CATCHER, RAY		70	*4-908-953-01	PLATE (A), SHIELD	
53	*4-342-117-00	CASE, SHIELD (MAIN), R		71	*2-280-622-41	SUPPORT (M3), HEXAGON	
54	*4-342-118-00	LID, SHIELD CASE, R		72	*4-870-266-00	SUPPORT, BLOCK	
55	*4-908-931-01	SHEET (A), INSULATING		73	*4-908-952-01	PLATE, SHIELD	
56	*4-908-929-01	BRACKET (A), CATCHER, RAY		74	7-685-146-19	SCREW +P 3X8 TYPE2 NON-SLIT	
57	*4-908-935-01	BRACKET, SWITCH		75	4-886-539-21	(Canadian,E)...PLATE (RIGHT), SIDE ORNAMENTAL	
58	4-886-538-21	(Canadian,E)...PLATE (LEFT), SIDE ORNAMENTAL			4-886-539-31	(US,AEP,UK)...PLATE (RIGHT), SIDE ORNAMENTAL	
59	*4-908-958-01	DAMPER (A)		76	2-269-798-01	HEAT SINK, TO-39	
60	3-703-685-31	SCREW (+BV 3X8)		77	*3-701-822-00	HOLDER, WIRE	
61	*4-908-915-01	BRACKET (LEFT), PANEL		78	4-908-963-01	NUT, SPECIAL	
62	*4-902-345-01	HEAT SINK		79	4-908-961-01	WASHER	
63	*4-879-920-00	SPACER, HEAT SINK		80	*4-908-951-01	REINFORCEMENT (B), PWB	
64	2-259-121-00	SCREW, TR		81	*4-908-950-01	REINFORCEMENT (A), PWB	
65	7-685-873-01	SCREW +BVTT 3X10 (S)		82	4-870-539-00	PLATE, GROUND	
66	*4-886-555-00	HEAT SINK		83	*4-885-843-02	LABEL, CAUTION, LASER	
67	4-870-272-00	HEAT SINK		84	*3-701-030-00	LABEL, SERIAL NUMBER	
68	4-887-707-00	RETAINER, TRANSFORMER		905	*1-614-475-11	PC BOARD, KEY BOARD	
				906	*1-614-476-11	PC BOARD, DISPLAY	
				907	*1-614-480-11	(Canadian,E)...PC BOARD, OPEN CLOSE SWITCH	
					*1-614-480-21	(US,AEP,UK)...PC BOARD, OPEN CLOSE SWITCH	

CDP-502ES/620ES

CDP-502ES/620ES

(3)

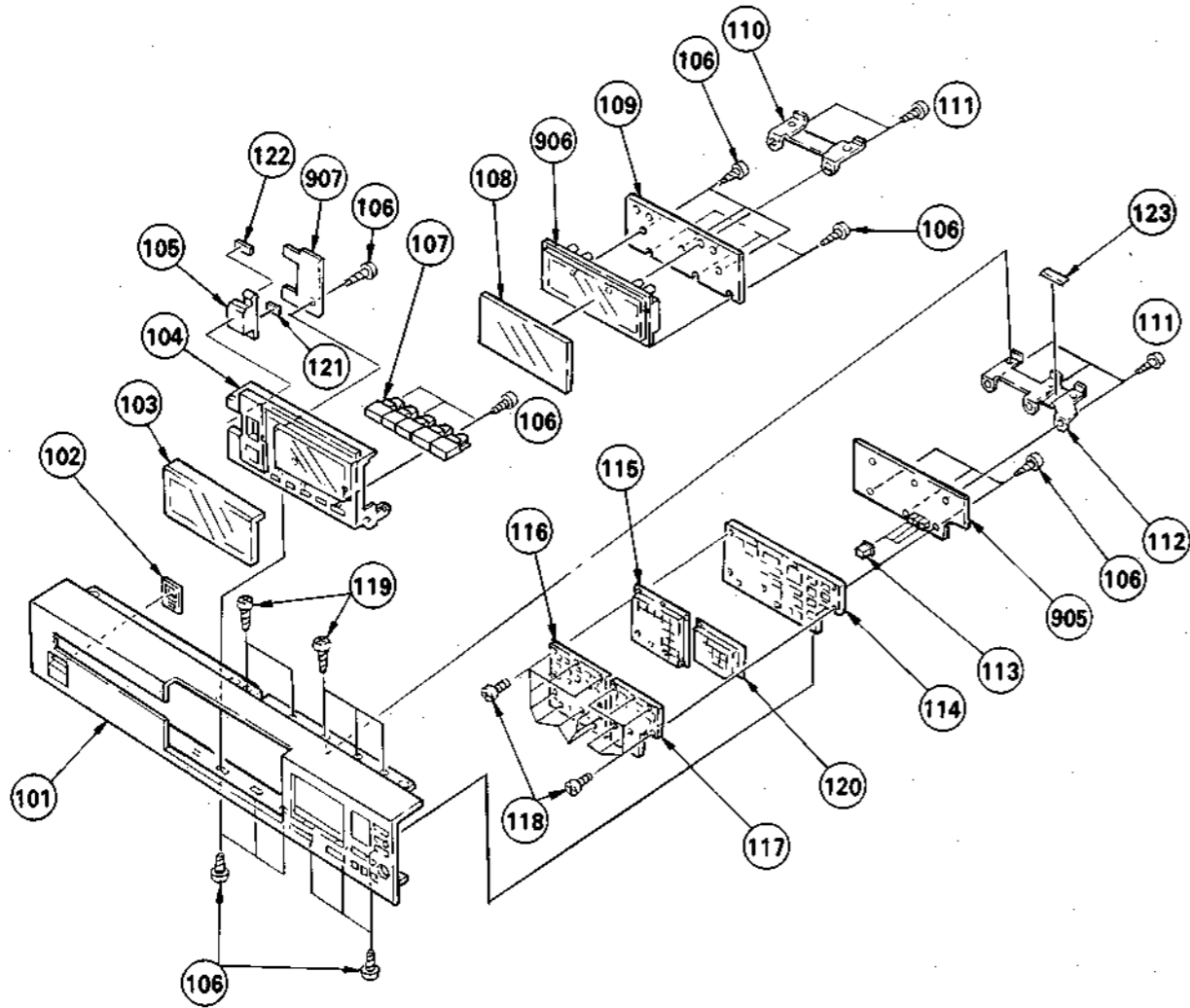

No.	Part No.	Description	Remarks	No.	Part No.	Description	Remarks
101	4-908-946-01	(E).....PANEL, FRONT		119	3-703-108-21	SCREW +BV 3X6, S TIGHT	
	4-908-946-21	(US,Canadian)...PANEL, FRONT		120	X-4908-907-1	KNOB (B) ASSY	
102	X-4908-901-1	ESCUTCHEON ASSY, POWER SWITCH		121	9-911-815-02	CUSHION	
103	4-908-904-01	PLATE, FROSTED		122	9-911-837-XX	SPACER	
104	X-4908-905-1	ESCUTCHEON ASSY, FROSTED PLATE		123	9-911-839-XX	PACKING, KNOB	
105	X-4908-904-1	BUTTON ASSY, O/C		902	*1-614-472-11	(Canadian,E)...PC BOARD, HEADPHONE JACK	
106	7-685-533-19	SCREW +BTP 2.6X6 TYPE2 N-S			*1-614-472-21	(US,AEP,UK)...PC BOARD, HEADPHONE JACK	
107	X-4908-902-1	KNOB (C) ASSY		903	*1-614-473-11	(Canadian,E)...PC BOARD, OUTPUT	
108	4-908-916-01	FILTER			*1-614-473-21	(US,AEP,UK)...PC BOARD, OUTPUT	
109	*4-908-937-01	HOLDER, INDICATION TUBE		908	*1-614-481-11	(Canadian,E)...PC BOARD, REMOTE CONTROL VR	
110	*4-908-912-01	RETAINER (A)			*1-614-481-21	(US,AEP,UK)...PC BOARD, REMOTE CONTROL VR	
111	7-685-134-14	SCREW +BTP 2.6X8 TYPE2 N-S		911	*1-560-242-11	BUS BAR 3P	
112	*4-908-913-01	RETAINER (B)		921	*1-611-717-11	PC BOARD, N	
113	4-908-955-01	BUTTON, MODE		922	A-4619-265-A	(US,AEP,UK)...MOUNTED, PCB, SERVO	
114	*4-908-945-01	RETAINER, KEY BOARD			A-4619-272-A	(Canadian)...MOUNTED, PCB, SERVO	
115	4-908-938-01	KNOB (A)			*A-4619-274-A	(E).....MOUNTED, PCB, SERVO	
116	4-908-932-01	ESCUTCHEON (A)		923	*A-4651-035-A	(E).....MOUNTED PCB, AUDIO	
117	4-908-933-01	ESCUTCHEON (B)			*A-4651-037-A	(US,AEP,UK)...MOUNTED PCB, AUDIO	
118	2-387-701-11	TAPPING (B)(1.4X5)			*A-4651-641-A	(Canadian)...MOUNTED PCB, AUDIO	

(4)

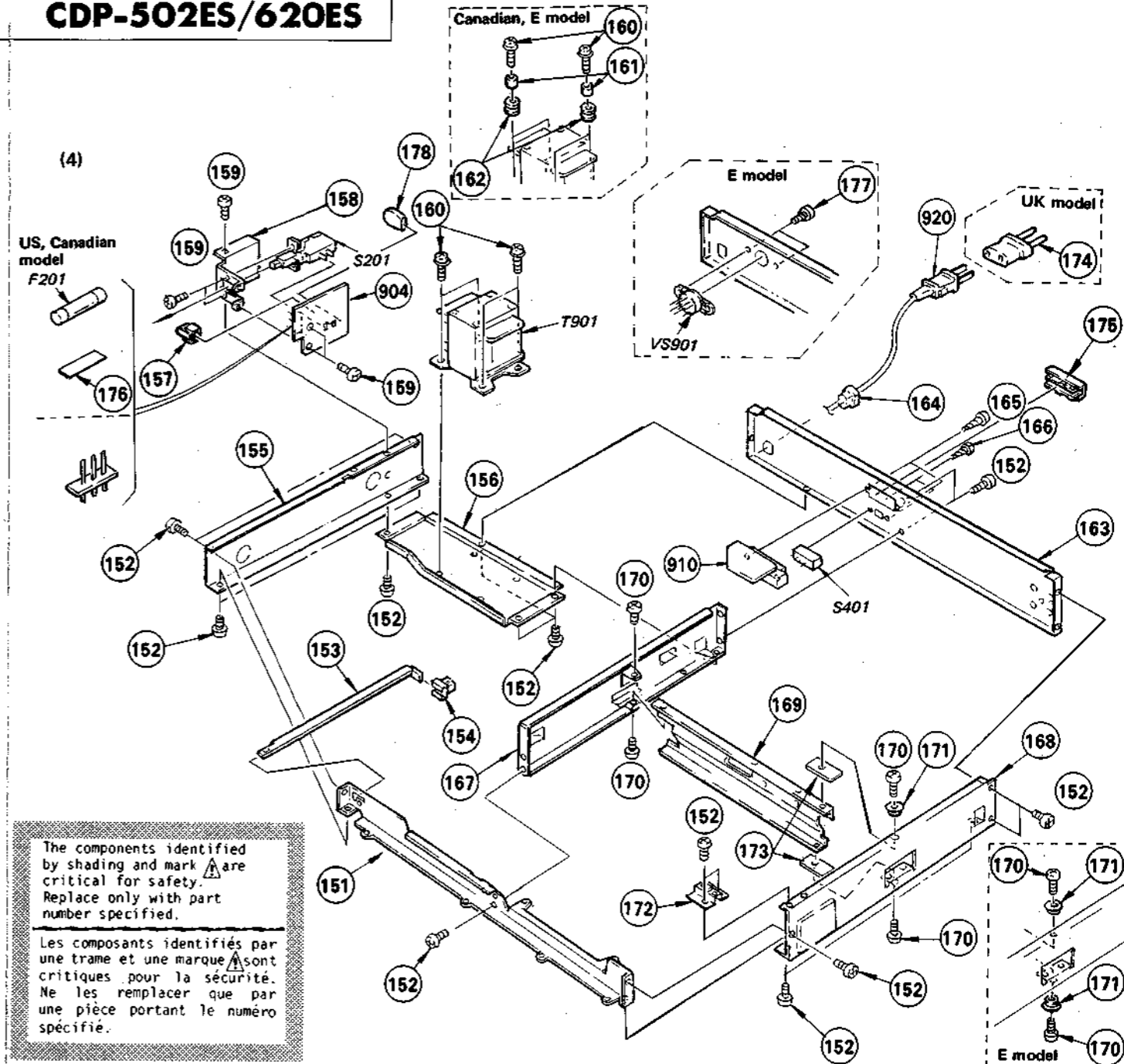

The components identified by shading and mark  are critical for safety. Replace only with part number specified.

Les composants identifiés par une trame et une marque  sont critiques pour la sécurité. Ne les remplacer que par une pièce portant le numéro spécifié.

No.	Part No.	Description	Remarks	No.	Part No.	Description	Remarks
151	*4-908-947-01	(Canadian,E)...ANGLE (F)		168	*4-908-941-01	(Canadian,E)...ANGLE (LEFT)	
	*4-908-947-11	(US,AEP,UK)...ANGLE (F)			4-908-941-11	(US,AEP,UK)...ANGLE (LEFT)	
152	3-703-685-31	SCREW (+BV 3X8)		169	*4-908-936-01	HEAT SINK	
153	*4-908-924-01	LEVER, POWER SWITCH		170	7-685-646-79	SCREW +BVTP 3X8 TYPE2 N-S	
154	4-866-342-00	JOINT (B), KNOB		171	2-371-561-00	(E,Canadian)...BUSHING (P), INSULATING	
155	*4-908-942-01	ANGLE (RIGHT)		172	*4-908-914-01	BRACKET (RIGHT), PANEL	
156	*4-908-934-01	CHASSIS, TRANSFORMER		173	*4-908-962-01	SHEET (C), INSULATING	
157	4-886-828-00	(AEP,UK)...COVER, LFT		174	1-526-565-00	AC PLUG ADAPTOR	
158	*4-908-911-01	BRACKET, POWER SWITCH		175	4-884-633-00	COVER, CONNECTOR	
159	7-685-871-01	SCREW +BVTT 3X6 (S)		176	3-701-946-22	(Canadian,US)...LABEL, FUSE	
160	4-820-330-41	(Canadian,E)...SCREW, BW, PLUS MINUS		177	7-621-775-10	SCREW +B 2.6X4	
	4-820-330-21	(US,AEP,UK)...SCREW, BW, PLUS MINUS		178	4-374-846-01	(AEP,UK)...COVER, CAPACITOR	
161	*4-886-511-00	(Canadian,E)...COLLAR, TRANSFORMER		904	*1-614-474-11	(Canadian,E)...PC BOARD, POWER SWITCH	
162	3-630-837-00	(E,Canadian)...BUSHING, STAND BY LAMP			*1-615-817-11	(US,AEP,UK)...PC BOARD, POWER SWITCH	
163	4-908-944-01	(Canadian)...PLATE, JACK			*1-614-483-11	(Canadian,E,UK)...PC BOARD, ACCESSORY PORT	
	4-908-944-11	(E).....PLATE, JACK			*1-614-483-21	(US,AEP)...PC BOARD, ACCESSORY PORT	
	4-908-944-31	(US,AEP,UK)...PLATE, JACK					
164	3-703-244-00	BUSHING (2104), CORD		924	1-533-131-00	(US,Canadian)...HOLDER, FUSE	
165	7-685-146-19	SCREW +P 3X8 TYPE2 NON-SLIT					
166	7-621-284-30	SCREW +P 2.6X8					
167	*4-908-943-01	ANGLE (C)					

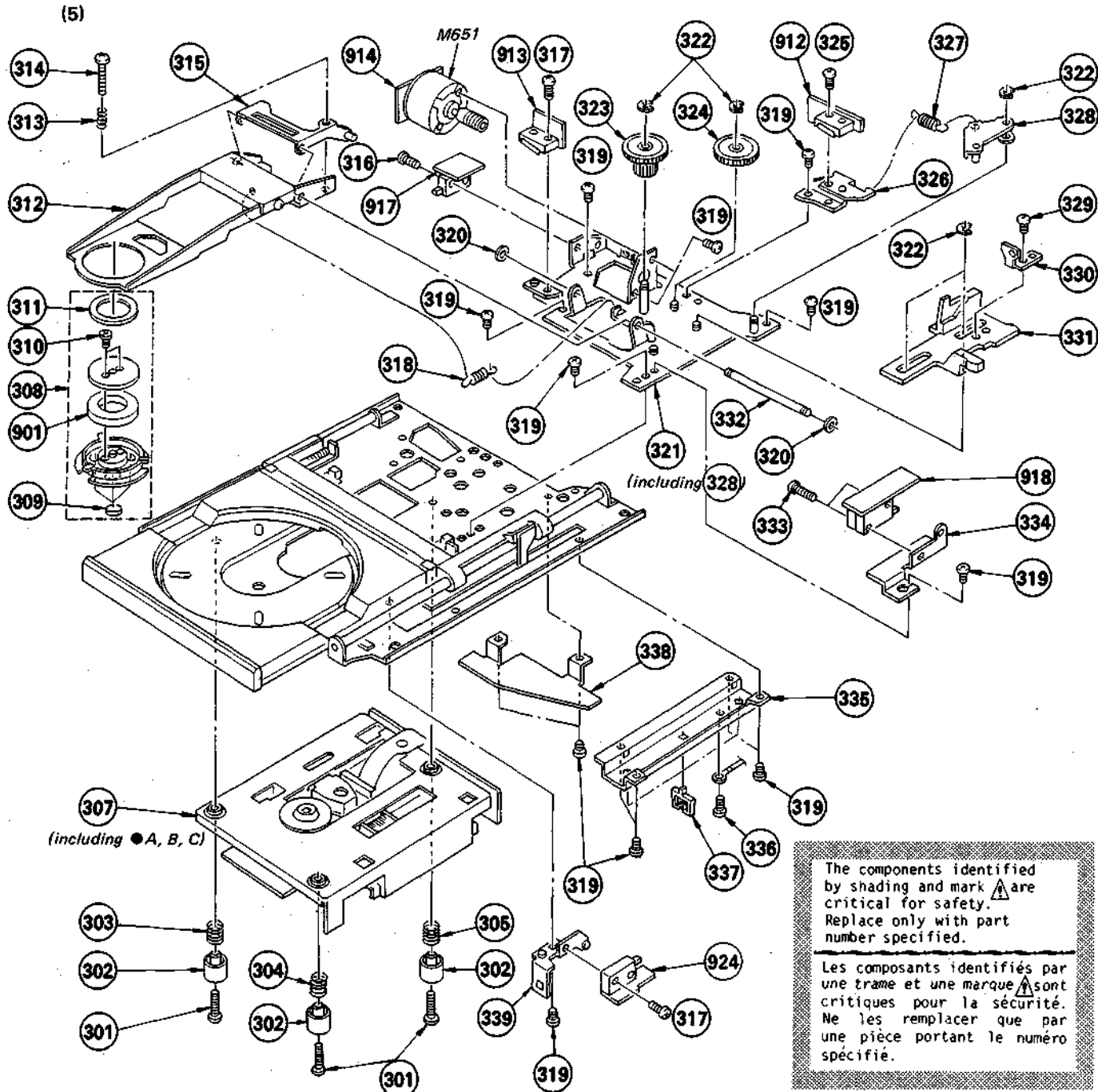

No.	Part No.	Description	REMARKS	No.	Part No.	Description	REMARKS
301	7-682-553-09	SCREW +B 3X20		325	7-621-257-55	SCREW +P 2.3X8	
302	4-908-592-01	POLE (A), INSULATOR		326	*4-908-522-01	BRACKET (B), SWITCH	
303	4-908-594-01	SPRING, COMPRESSION		327	4-908-556-01	SPRING, TENSION (LOCK LEVER)	
304	4-908-595-01	SPRING, COMPRESSION		328	*X-4908-504-1	LEVER ASSY, LOCK	
305	4-908-596-01	SPRING, COMPRESSION		329	7-685-132-19	SCREW +BTP 2.6X8 TYPE2 N-S	
306	4-908-597-01	SCREW +BTP 2.6X10 (S)		330	*4-908-521-01	PLATE, SWITCH	
308	A-4675-077-A	PULLEY ASSY, PRESS		331	4-908-570-01	CAM, C	
309	4-908-537-01	FELT, PRESS		332	4-908-513-01	SHAFT, FULCRUM, C ARM	
310	4-908-618-01	SCREW (+BTP)(2X4)		333	7-621-259-80	SCREW +P 2.6X14	
311	4-908-551-01	CUSHION		334	*4-908-532-01	BRACKET (A), SWITCH	
312	*X-4908-510-1	ARM ASSY, C		335	*4-908-508-01	COVER, ROPE	
313	4-908-559-01	SPRING, COMPRESSION		336	7-685-751-04	SCREW +PTT 3X6 (S)	
314	7-621-775-80	SCREW +B 2.6X16		337	4-308-840-00	HOLDER, WIRE	
315	X-4908-513-1	PLATE ASSY, ADJUSTMENT, ARM		338	*4-908-597-01	COVER, BELT	
316	7-685-864-01	SCREW +BVT 2.6X10 (S)		339	*4-908-541-01	BRACKET (C), SWITCH	
317	7-621-284-30	SCREW +P 2.6X8		340	4-908-621-01	SHEET	
318	4-908-555-01	SPRING, TENSION (C ARM)		901	1-452-340-11	MAGNET	
319	7-621-259-10	SCREW +P 2.6X3		912	*1-614-023-11	PC BOARD, L.C SW	
320	3-558-708-21	WASHER, STOPPER		913	*1-614-024-11	PC BOARD, CHUCKING SW	
321	*X-4908-509-1	CHASSIS ASSY, SUB		914	*1-614-025-11	PC BOARD, CHUCKING MOTOR	
322	7-624-106-04	STOP RING 3.0, TYPE -E		917	*1-614-028-11	PC BOARD, LASER SW	
323	4-908-528-01	GEAR (A)		918	*1-614-029-11	PC BOARD, LOAD IN SW	
324	4-908-529-01	GEAR (B)		924	*1-614-030-11	PC BOARD, LOAD OUT SW	

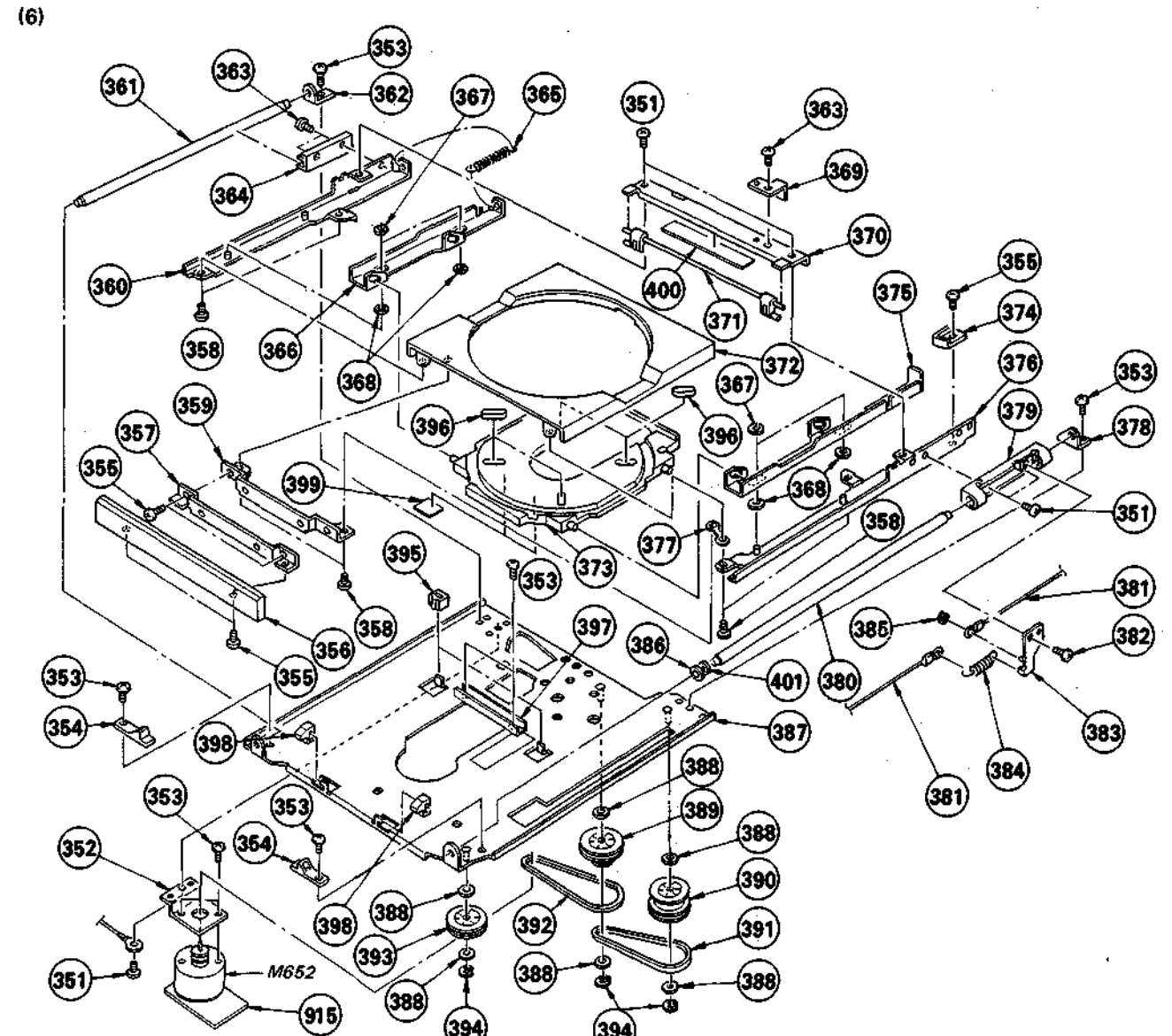

No.	Part No.	Description	REMARKS	No.	Part No.	Description	REMARKS
351	7-685-870-09	SCREW +BVT 3X5 (S)		377	*4-908-608-01	PLATE (A), GROUND	
352	*4-908-523-01	BRACKET, MOTOR		378	*4-908-531-01	PLATE (RIGHT), BEARING	
353	7-621-259-10	SCREW +P 2.6X3		379	4-908-574-01	BEARING (RIGHT), GUIDE	
354	4-908-540-01	GUIDE, ASSIST		380	4-908-503-01	SHAFT (RIGHT), GUIDE	
355	7-621-775-20	SCREW +B 2.6X5		381	4-908-544-01	ROPE	
356	4-908-571-11	PANEL, LOADING		382	7-685-132-19	SCREW +BTP 2.6X5 TYPE2 N-S	
357	*4-908-539-01	BRACKET (B), LOADING PANEL		383	*X-4908-502-1	BRACKET ASSY, ROPE	
358	7-685-646-29	SCREW +BVT 3X8 TYPE2 SLIT		384	4-908-553-01	SPRING, COMPRESSION (ROPE)	
359	*4-908-538-01	BRACKET (A), LOADING PANEL		385	7-624-104-04	STOP RING 2.0, TYPE -E	
360	X-4908-508-1	PLATE ASSY (LEFT), SIDE, TABLE		386	4-908-550-01	STOPPER, RUBBER	
361	4-908-505-01	SHAFT (LEFT), GUIDE		387	*X-4908-511-1	CHASSIS ASSY, MECHANICAL	
362	*4-908-530-01	PLATE (LEFT), BEARING		388	3-701-441-21	WASHER	
363	7-685-861-09	SCREW +BVT 2.6X5 (S)		389	4-908-519-01	PULLEY (A)	
364	4-908-572-01	BEARING (LEFT), GUIDE		390	4-908-525-01	PULLEY (C)	
365	4-908-552-01	SPRING, COMPRESSION		391	3-671-077-00	BELT, FF	
366	*4-908-562-01	PLATE (LEFT), CAM, DISK		392	4-908-591-01	BELT, DRIVING	
367	3-558-708-21	WASHER, STOPPER		393	4-908-524-01	PULLEY (B)	
368	3-701-439-11	WASHER		394	7-624-106-04	STOP RING 3.0, TYPE -E	
369	*4-908-609-01	PLATE (B), GROUND		395	4-887-175-00	RUBBER, STOPPER	
370	*4-908-533-01	REINFORCEMENT, TABLE		396	4-908-543-01	RETAINER, DISK	
371	4-908-534-01	LEVER, FUNCTION		397	*4-908-598-01	REINFORCEMENT, CHASSIS	
372	4-908-584-01	TABLE, DISK		398	4-908-590-01	RETAINER, TABLE	
373	X-4908-506-1	PLATE ASSY, DISK		399	*4-908-964-01	SHEET, PS, DT	
374	4-908-520-01	PLATE, LOCK		400	*4-908-965-01	SHEET	
375	*4-908-561-01	PLATE (RIGHT), CAM, DISK		401	4-908-622-01	CUSHION (S)	
376	X-4908-507-1	PLATE ASSY (RIGHT), SIDE, TABLE		915	*1-614-026-11	PC BOARD, LOADING MOTOR	

(7)

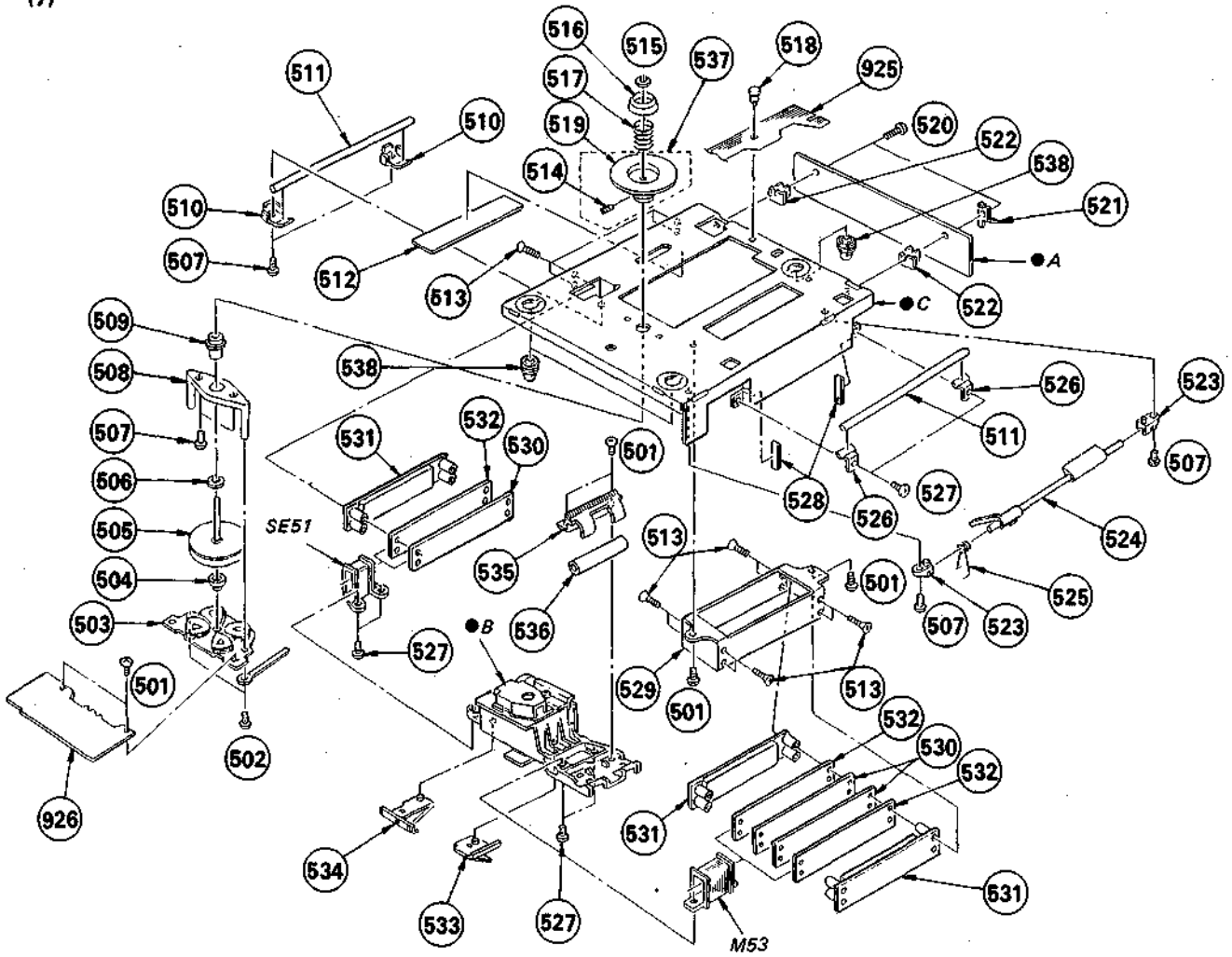

No.	Part No.	Description	REMARKS	No.	Part No.	Description	REMARKS
501	7-621-775-10	SCREW +B 2.6X4		521	*4-908-232-01	LUG	
502	7-685-533-19	SCREW +BTP 2.6X6 TYPE2 N-S		522	4-908-222-01	HOLDER, PC BOARD	
503	A-4675-068-A	BRACKET ASSY, MOTOR (L151,152)		523	4-908-220-01	HOLDER, ROD	
504	2-622-105-01	RETAINER, THRUST		524	4-908-227-01	LEVER, LOCK	
505	A-4675-069-A	ROTOR ASSY		525	4-908-230-01	SPRING	
506	3-701-439-21	WASHER		526	4-908-217-01	RETAINER (B), SLIDE SHAFT	
507	7-621-773-95	SCREW +B 2.6X6		527	7-621-775-20	SCREW +B 2.6X5	
508	4-908-216-01	HOLDER, STATOR		528	*3-548-366-02	CUSHION	
509	4-908-206-01	BEARING, SPINDLE		529	4-908-203-01	YOKE (A)	
510	4-908-205-01	RETAINER (A), SLIDE SHAFT		530	4-908-214-01	YOKE (C)-1	
511	4-908-201-01	SHAFT, SLIDE		531	A-4675-070-A	MAGNET ASSY, LINEAR	
512	2-270-836-00	RUBBER, RETAINER		532	4-908-215-01	YOKE (C)-2	
513	7-621-559-80	SCREW +K 2.6X14		533	4-908-225-01	RETAINER (A), LEAD	
514	7-621-734-09	SET-SCT, HEX. 2.6X3		534	4-908-219-01	RETAINER (B), LEAD	
515	3-558-708-21	WASHER, STOPPER		535	4-908-224-01	HOLDER, BEARING	
516	4-908-212-01	CAP, CENTERING		536	4-908-221-01	BEARING	
517	4-908-213-01	SPRING, COMPRESSION		537	X-4908-202-1	PULLEY ASSY, DISK	
518	3-531-576-01	RIVET		538	4-908-593-01	INSULATOR	
519	4-908-211-02	PULLEY, DISK		925	A-4646-215-A	MOUNTED PCB, FLEXIBLE	
520	7-621-259-65	SCREW +P 2.6X10		926	1-614-086-11	PC BOARD, BSL MOTOR	

SECTION 7
ELECTRICAL PARTS LIST

NOTE:

- Items marked " * " are not stocked since they are seldom required for routine service. Some delay should be anticipated when ordering these items.
- If there are two or more same circuits in a set such as a stereophonic machine, only typical circuit parts may be indicated and capacitors and resistors in other same circuits may be omitted.

CAPACITORS:

MF:µF, PF:µµF.

RESISTORS

- All resistors are in ohms.
- F : nonflammable

COILS

MMH : mH, UH : µH

SEMICONDUCTORS

In each case, U : µ, for example:
UA....: µA...., UPA....: µPA...., UPC....: µPC,
UPD....: µPD...

The components identified by shading and mark Δ are critical for safety. Replace only with part number specified.

Les composants identifiés par une trame et une marque Δ sont critiques pour la sécurité. Ne les remplacer que par une pièce portant le numéro spécifié.

ELECTRICAL PARTS

Ref.No.	Part No.	Description
901	1-452-340-11	MAGNET
902	*1-614-472-11	(Canadian,E)...PC BOARD, HEADPHONE JACK
	*1-614-472-21	(US,AEP,UK)...PC BOARD, HEADPHONE JACK
903	*1-614-473-11	(Canadian,E)...PC BOARD, OUTPUT
	*1-614-473-21	(US,AEP,UK)...PC BOARD, OUTPUT
904	*1-614-474-11	(Canadian,E)...PC BOARD, POWER SWITCH
	*1-615-817-11	(US,AEP,UK)...PC BOARD, POWER SWITCH
905	*1-614-475-11	PC BOARD, KEY BOARD
906	*1-614-476-11	PC BOARD, DISPLAY
907	*1-614-480-11	(Canadian,E)...PC BOARD, OPEN CLOSE SWITCH
	*1-614-480-21	(US,AEP,UK)...PC BOARD, OPEN CLOSE SWITCH
908	*1-614-481-11	(Canadian,E)...PC BOARD, REMOTE CONTROL VR
	*1-614-481-21	(US,AEP,UK)...PC BOARD, REMOTE CONTROL VR
909	*1-614-482-11	(Canadian,E)...PC BOARD, REMOTE CONTROL MOTOR
	*1-614-482-21	(US,AEP,UK)...PC BOARD, REMOTE CONTROL MOTOR
910	*1-614-483-11	(Canadian,E,UK)...PC BOARD, ACCESSORY PORT
	*1-614-483-21	(US,AEP)...PC BOARD, ACCESSORY PORT
911	*1-560-242-11	BUS BAR 3P
912	*1-614-023-11	PC BOARD, L.C SW
913	*1-614-024-11	PC BOARD, CHACKING SW
914	*1-614-025-11	PC BOARD, CHACKING MOTOR
915	*1-614-026-11	PC BOARD, LOADING MOTOR
916	1-535-416-00	TERMINAL
917	*1-614-028-11	PC BOARD, LASER SW
918	*1-614-029-11	PC BOARD, LOAD IN SW
919	*1-614-030-11	PC BOARD, LOAD OUT SW
920	1-535-386-00	CORD, POWER
	*1-535-701-00	(US,Canadian)...CORD, POWER
	*1-535-795-00	(AEP)...CORD, POWER
	*1-656-035-00	(UK)...CORD, POWER
921	*1-611-717-11	PC BOARD, N
922	A-4619-265-A	(US,AEP,UK)...MOUNTED, PCB, SERVO
	A-4619-272-A	(Canadian)...MOUNTED, PCB, SERVO
	*A-4619-274-A	(E).....MOUNTED, PCB, SERVO
923	*A-4651-035-A	(E).....MOUNTED PCB, AUDIO
	*A-4651-037-A	(US,AEP,UK)...MOUNTED PCB, AUDIO
	*A-4651-641-A	(Canadian)...MOUNTED PCB, AUDIO
924	1-533-131-00	(US,Canadian)...HOLDER, FUSE
925	A-4646-215-A	MOUNTED PCB, FLEXIBLE
926	1-614-086-11	PC BOARD, BSL MOTOR
C51	1-135-008-00	TANTALUM (CHIP)2.2MF 20% 6.3V
C151	1-162-302-31	CERAMIC 0.0022MF 20% 16V
C152	1-162-302-31	CERAMIC 0.0022MF 20% 16V
C153	1-161-494-00	CERAMIC 0.0022MF 30% 25V
C154	1-161-494-00	CERAMIC 0.0022MF 30% 25V
C201	1-161-744-00	CERAMIC 0.01MF 400V

ELECTRICAL PARTS

Ref.No.	Part No.	Description
C202	1-161-742-51	(AEP,UK)...CERAMIC 0.0022MF 20% 400V
C203	1-161-742-51	(AEP,UK)...CERAMIC 0.0022MF 20% 400V
C204	1-161-742-51	(AEP,UK)...CERAMIC 0.0022MF 20% 400V
C205	1-161-742-51	(AEP,UK)...CERAMIC 0.0022MF 20% 400V
C206	1-161-744-00	(US)...CAP, CERAMIC 0.01MF 400V
C207	1-161-744-00	(US)...CAP, CERAMIC 0.01MF 400V
C301	1-104-239-00	POLYSTYRENE 0.0015MF 5% 125V
C302	1-107-322-00	MICA 22PF 5% 500V
C303	1-131-450-00	TANTALUM 1MF 20% 50V
C304	1-123-336-00	ELECT 470MF 20% 25V
C305	1-104-266-00	POLYSTYRENE 180PF 5% 500V
C307	1-131-450-00	TANTALUM 1MF 20% 50V
C308	1-130-960-00	FILM 0.01MF 2% 100V
C309	1-110-213-00	MYLAR 0.01MF 20% 160V
C310	1-123-373-00	ELECT 47MF 20% 63V
C351	1-131-380-00	TANTALUM 33MF 10% 10V
C352	1-162-294-31	CERAMIC 0.001MF 10% 50V
C353	1-131-526-00	TANTALUM 33MF 20% 10V
C354	1-131-450-00	TANTALUM 1MF 20% 50V
C355	1-123-334-00	ELECT 220MF 20% 25V
C356	1-102-523-00	CERAMIC 56PF 5% 50V
C357	1-102-514-00	CERAMIC 22PF 5% 50V
C358	1-162-294-31	CERAMIC 0.001MF 10% 50V
C359	1-131-526-00	TANTALUM 33MF 20% 10V
C360	1-123-334-00	ELECT 220MF 20% 25V
C361	1-131-526-00	TANTALUM 33MF 20% 10V
C362	1-131-450-00	TANTALUM 1MF 20% 50V
C363	1-131-450-00	TANTALUM 1MF 20% 50V
C364	1-131-450-00	TANTALUM 1MF 20% 50V
C365	1-131-450-00	TANTALUM 1MF 20% 50V
C366	1-123-333-00	ELECT 100MF 20% 25V
C367	1-123-333-00	ELECT 100MF 20% 25V
C368	1-101-005-00	(Canadian,E)...CERAMIC 0.022MF 50V
C368	1-161-974-00	(US,AEP,UK)...CAP, CERAMIC 0.1MF 20% 16V
C369	1-101-005-00	(Canadian,E)...CERAMIC 0.022MF 50V
C369	1-161-974-00	(US,AEP,UK)...CAP, CERAMIC 0.1MF 20% 16V
C370	1-131-450-00	TANTALUM 1MF 20% 50V
C371	1-136-327-11	FILM 0.0027MF 2% 100V
C372	1-130-967-00	FILM 0.0027MF 3% 100V
C373	1-130-967-00	FILM 0.0027MF 3% 100V
C374	1-130-967-00	FILM 0.0027MF 3% 100V
C375	1-130-967-00	FILM 0.0027MF 3% 100V
C376	1-130-967-00	FILM 0.0027MF 3% 100V
C377	1-130-967-00	FILM 0.0027MF 3% 100V
C378	1-136-327-11	FILM 0.0027MF 2% 100V

ELECTRICAL PARTS

Ref.No.	Part No.	Description			
C379	1-107-328-00	MICA	47PF	5%	500V
C383	1-161-974-00	(US,AEP,UK)...CAP, CERAMIC	0.1MF	20%	16V
C501	1-136-163-00	FILM	0.068MF	5%	50V
C502	1-162-304-31	CERAMIC	0.0047MF	30%	16V
C503	1-130-487-00	MYLAR	0.022MF	5%	50V
C504	1-123-343-00	ELECT	33MF	20%	25V
C505	1-123-343-00	ELECT	33MF	20%	25V
C506	1-123-343-00	ELECT	33MF	20%	25V
C507	1-123-343-00	ELECT	33MF	20%	25V
C510	1-136-165-00	FILM	0.1MF	5%	50V
C511	1-123-343-00	ELECT	33MF	20%	25V
C512	1-123-343-00	ELECT	33MF	20%	25V
C521	1-130-475-00	MYLAR	0.0022MF	5%	50V
C522	1-130-475-00	MYLAR	0.0022MF	5%	50V
C523	1-130-487-00	MYLAR	0.022MF	5%	50V
C524	1-162-291-31	CERAMIC	560PF	10%	50V
C525	1-136-165-00	FILM	0.1MF	5%	50V
C526	1-130-471-00	MYLAR	0.001MF	5%	50V
C527	1-136-169-00	FILM	0.22MF	5%	50V
C528	1-136-161-00	FILM	0.047MF	5%	50V
C529	1-136-159-00	FILM	0.033MF	5%	50V
C530	1-162-294-31	CERAMIC	0.001MF	10%	50V
C531	1-130-475-00	MYLAR	0.0022MF	5%	50V
C532	1-162-290-31	CERAMIC	470PF	10%	50V
C533	1-136-165-00	FILM	0.1MF	5%	50V
C534	1-136-169-00	FILM	0.22MF	5%	50V
C535	1-130-475-00	MYLAR	0.0022MF	5%	50V
C537	1-136-161-00	FILM	0.047MF	5%	50V
C541	1-123-343-00	ELECT	33MF	20%	25V
C542	1-131-371-00	TANTALUM	10MF	10%	16V
C543	1-123-343-00	ELECT	33MF	20%	25V
C548	1-131-369-00	TANTALUM	4.7MF	10%	16V
C571	1-162-294-31	CERAMIC	0.001MF	10%	50V
C572	1-162-294-31	CERAMIC	0.001MF	10%	50V
C601	1-131-450-00	TANTALUM	1MF	20%	50V
C602	1-131-380-00	TANTALUM	33MF	20%	10V
C603	1-131-380-00	TANTALUM	33MF	20%	10V
C605	1-136-169-00	FILM	0.22MF	5%	50V
C606	1-123-228-00	ELECT	1MF	20%	50V
C607	1-136-165-00	FILM	0.1MF	5%	50V
C608	1-130-481-00	MYLAR	0.0068MF	5%	50V
C609	1-162-290-31	CERAMIC	470PF	10%	50V
C610	1-102-647-00	CERAMIC	39PF	5%	50V
C611	1-102-658-00	CERAMIC	180PF	5%	50V
C612	1-102-725-00	CERAMIC	36PF	5%	50V
C613	1-162-302-31	CERAMIC	0.0022MF	30%	16V
C614	1-162-302-31	CERAMIC	0.0022MF	30%	16V
C615	1-136-153-00	FILM	0.01MF	5%	50V
C616	1-124-186-00	ELECT	10MF	20%	50V
C617	1-123-611-00	ELECT	1MF	20%	50V
C618	1-136-153-00	FILM	0.01MF	5%	50V
C619	1-136-165-00	FILM	0.1MF	5%	50V
C620	1-131-380-00	TANTALUM	33MF	20%	10V
C621	1-124-080-00	ELECT	33MF	20%	25V

ELECTRICAL PARTS

Ref.No.	Part No.	Description			
C622	1-123-343-00	ELECT	33MF	20%	25V
C651	1-136-157-00	FILM	0.022MF	5%	50V
C652	1-136-157-00	FILM	0.022MF	5%	50V
C653	1-136-157-00	FILM	0.022MF	5%	50V
C654	1-130-479-00	MYLAR	0.0047MF	5%	50V
C655	1-130-479-00	MYLAR	0.0047MF	5%	50V
C701	1-131-380-00	TANTALUM	33MF	20%	10V
C704	1-131-380-00	TANTALUM	33MF	20%	10V
C705	1-162-284-31	CERAMIC	150PF	10%	50V
C706	1-162-284-31	CERAMIC	150PF	10%	50V
C707	1-162-294-31	CERAMIC	0.001MF	10%	50V
C708	1-162-294-31	CERAMIC	0.001MF	10%	50V
C709	1-162-306-31	CERAMIC	0.01MF	20%	16V
C710	1-131-380-00	TANTALUM	33MF	20%	10V
C711	1-131-380-00	TANTALUM	33MF	20%	10V
C712	1-161-055-00	CERAMIC	0.022MF	20%	25V
C721	1-161-974-00	(US,AEP,UK)...CAP, CERAMIC	0.1MF	20%	16V
C730	1-123-307-00	ELECT	100MF	20%	6.3V
C731	1-123-307-00	ELECT	100MF	20%	6.3V
C801	1-131-374-00	TANTALUM	33MF	20%	16V
C802	1-161-055-00	CERAMIC	0.022MF	20%	25V
C851	1-123-611-00	ELECT	1MF	20%	50V
C852	1-123-613-00	ELECT	3.3MF	20%	50V
C853	1-162-288-31	CERAMIC	330PF	10%	50V
C854	1-123-821-00	ELECT	47MF	20%	16V
C901	1-123-842-00	ELECT	330MF	20%	25V
C902	1-107-325-00	MICA	10PF	0.5PF	500V
C903	1-123-345-00	ELECT	100MF	20%	35V
C904	1-123-624-00	ELECT	470MF	20%	120V
C905	1-123-380-00	ELECT	1MF	20%	50V
C906	1-123-345-00	ELECT	100MF	20%	35V
C907	1-123-380-00	ELECT	1MF	20%	50V
C908	1-123-343-00	ELECT	33MF	20%	25V
C909	1-131-450-00	TANTALUM	1MF	20%	50V
C921	1-123-327-00	ELECT	4700MF	20%	16V
C922	1-131-450-00	TANTALUM	1MF	20%	50V
C923	1-123-311-00	ELECT	1000MF	20%	10V
C981	1-130-691-00	FILM	1MF	10%	125V
C982	1-136-165-00	FILM	0.1MF	5%	50V
C991	1-123-335-00	ELECT	330MF	20%	25V
C992	1-124-530-00	ELECT	100MF	20%	50V
C993	1-124-346-00	ELECT	220MF	20%	35V
C994	1-131-347-00	TANTALUM	1MF	10%	35V
C995	1-123-617-00	ELECT	10MF	20%	16V
CNJ302*	1-564-505-11	PLUG, CONNECTOR	2P		
CNJ303*	1-564-505-21	PLUG, CONNECTOR	2P		
CNJ304*	1-564-506-11	PLUG, CONNECTOR	3P		
CNJ305*	1-564-507-11	PLUG, CONNECTOR	4P		
CNJ306*	1-564-507-11	PLUG, CONNECTOR	4P		
CNJ307*	1-564-507-21	PLUG, CONNECTOR	4P		
CNJ353*	1-564-519-21	PLUG, CONNECTOR	4P		
CNJ354*	1-564-519-11	PLUG, CONNECTOR	4P		
CNJ501	1-564-711-11	PIN, CONNECTOR (SMALL TYPE)	9P		
CNJ502*	1-564-706-11	PIN, CONNECTOR (SMALL TYPE)	4P		
CNJ503	1-564-710-11	PIN, CONNECTOR (SMALL TYPE)	8P		
CNJ504*	1-564-706-31	PIN, CONNECTOR (SMALL TYPE)	4P		

The components identified by shading and mark **▲** are critical for safety. Replace only with part number specified.

Les composants identifiés par une trame et une marque **▲** sont critiques pour la sécurité. Ne les remplacer que par une pièce portant le numéro spécifié.

CDP-502ES/620ES

ELECTRICAL PARTS

Ref.No.	Part No.	Description
	CNJ505*1-564-706-11	PIN, CONNECTOR (SMALL TYPE) 4P
	CNJ506*1-564-505-11	PLUG, CONNECTOR 2P
	CNJ601*1-564-707-11	PIN, CONNECTOR (SMALL TYPE) 5P
	CNJ602*1-564-704-11	PIN, CONNECTOR (SMALL TYPE) 2P
	CNJ603*1-564-708-11	PIN, CONNECTOR (SMALL TYPE) 6P
	CNJ604*1-564-706-11	PIN, CONNECTOR (SMALL TYPE) 4P
	CNJ701*1-564-710-11	PIN, CONNECTOR (SMALL TYPE) 8P
	CNJ702*1-564-706-41	PIN, CONNECTOR (SMALL TYPE) 4P
	CNJ703*1-564-709-11	PIN, CONNECTOR (SMALL TYPE) 7P
	CNJ704 1-564-710-11	PIN, CONNECTOR (SMALL TYPE) 8P
	CNJ705*1-564-705-11	PIN, CONNECTOR (SMALL TYPE) 3P
	CNJ706*1-564-704-11	PIN, CONNECTOR (SMALL TYPE) 2P
	CNJ707*1-564-708-11	PIN, CONNECTOR (SMALL TYPE) 6P
	CNJ708*1-564-706-11	PIN, CONNECTOR (SMALL TYPE) 4P
	CNJ709*1-564-705-31	PIN, CONNECTOR (SMALL TYPE) 3P
	CNJ710*1-564-704-11	PIN, CONNECTOR (SMALL TYPE) 2P
	CNJ711*1-564-705-11	PIN, CONNECTOR (SMALL TYPE) 3P
	CNP601*1-564-519-11	PLUG, CONNECTOR 4P
	CNP602*1-564-505-11	PLUG, CONNECTOR 2P
	CNP603*1-564-505-21	PLUG, CONNECTOR 2P
	CNP604*1-564-505-31	PLUG, CONNECTOR 2P
	CNP605*1-564-505-41	PLUG, CONNECTOR 2P
	CNP606*1-564-506-11	PLUG, CONNECTOR 3P
	CNP607*1-564-517-11	PLUG, CONNECTOR 2P
D51	8-719-911-19	DIODE 1SS119
D301	8-719-910-65	DIODE HZ6B2L
D302	8-719-224-12	DIODE 10YD1.3
D401	8-719-910-65	DIODE HZ6B2L
D402	8-719-224-12	DIODE 10YD1.3
D501	8-719-911-19	DIODE 1SS119
D504	8-719-951-13	DIODE HZ5CLL
D505	8-719-911-19	DIODE 1SS119
D507	8-719-101-32	DIODE RD2.7EL1
D508	8-719-911-19	DIODE 1SS119
D601	8-719-902-79	DIODE KW1236Z
D651	8-719-290-02	DIODE 10E-2
D652	8-719-200-02	DIODE 10E-2
D653	8-719-200-02	DIODE 10E-2
D701	8-719-911-19	DIODE 1SS119
D702	8-719-911-19	DIODE 1SS119
D703	8-719-200-02	DIODE 10E-2
D704	8-719-100-65	DIODE RD12EB2
D710	8-719-911-19	DIODE 1SS119
D801	8-719-911-19	DIODE 1SS119
D802	8-719-911-19	DIODE 1SS119
D803	8-719-911-19	DIODE 1SS119
D804	8-719-911-19	DIODE 1SS119
D805	8-719-911-19	DIODE 1SS119
D806	8-719-911-19	DIODE 1SS119
D807	8-719-922-25	DIODE PG2222SY
D811	8-719-922-24	DIODE BR2222S
D812	8-719-900-28	DIODE EBG3432S
D813	8-719-934-34	DIODE AA3432S
D851	8-719-110-32	DIODE PH302B

ELECTRICAL PARTS

Ref.No.	Part No.	Description
D901	8-719-200-68	DIODE EQB01-08Q
D902	8-719-200-89	DIODE 21DQ05
D905	8-719-224-11	DIODE 10YD2.4A
D906	8-719-902-87	DIODE EQB01-08Q
D921	8-719-200-31	DIODE 21DQ05
D922	8-719-200-31	DIODE 21DQ05
D923	8-719-200-31	DIODE 21DQ05
D924	8-719-200-31	DIODE 21DQ05
D955	8-719-224-11	DIODE 10YD2.4A
D956	8-719-902-87	DIODE EQB01-08Q
D991	8-719-911-19	DIODE 1SS119
D992	8-719-911-19	DIODE 1SS119
D993	8-719-911-19	DIODE 1SS119
D994	8-719-200-02	DIODE 10E-2
D995	8-719-200-02	DIODE 10E-2
D996	8-719-100-35	DIODE RD5.1EB2
D997	8-719-100-98	DIODE RD30EB2
FL201	1-519-333-00	INDICATOR TUBE, FLUORESCENT
FL801	1-519-333-11	INDICATOR TUBE, FLUORESCENT
IC301	8-759-903-53	IC LF353H
IC302	8-759-900-72	IC NE5532P
IC303	8-759-900-72	IC NE5532P
IC304	8-759-900-72	IC NE5532P
IC351	8-759-202-13	IC TC74HC04P
IC352	8-752-015-20	IC CX20152
IC353	8-759-801-74	IC CX20198
IC354	8-759-745-61	IC NJM4560D-D
IC355	8-759-140-53	IC UPD4053BC
IC401	8-759-903-53	IC LF353H
IC402	8-759-900-72	IC NE5532P
IC403	8-759-900-72	IC NE5532P
IC404	8-759-900-72	IC NE5532P
IC501	8-752-010-80	IC CX20108
IC502	8-759-700-58	IC NJM4558D-FA
IC503	8-759-600-02	IC M5218L
IC601	8-759-912-52	IC CX23035
IC602	8-759-913-72	IC MB8416-20LPF
IC603	8-759-912-53	IC CX23034
IC604	8-759-990-82	IC TL082CP
IC701	8-759-914-69	IC MSM6404A-44RS
IC702	8-759-915-52	IC MSM6404A-40RS
IC703	8-759-602-25	IC M50760-414P
IC704	8-759-220-04	IC TC40H004P
IC705	8-759-600-24	IC M54543L
IC801	8-759-600-48	IC M50732SP
IC802	8-759-812-90	IC LB1290
IC803	8-759-812-90	IC LB1290
IC804	8-759-800-76	IC LB1245
IC851	8-752-010-60	IC CX20106
IC901	8-759-700-11	IC NJM78M05A
IC902	8-759-170-12	IC NJM78M12A
IC903	8-759-700-24	IC NJM79M12A
IC921	8-759-700-51	IC NJM7805A
IC951	8-759-700-20	IC NJM79M05A
IC971	8-759-700-28	IC NJM7905A

The components identified by shading and mark Δ are critical for safety. Replace only with part number specified.

Les composants identifiés par une trame et une marque Δ sont critiques pour la sécurité. Ne les remplacer que par une pièce portant le numéro spécifié.

ELECTRICAL PARTS

Ref.No.	Part No.	Description
J251	1-562-042-00	SOCKET,CONNECTOR 26P
J321	1-507-863-21	JACK, LARGE TYPE
L51	1-408-563-00	MICRO INDUCTOR 10UH
L201	1-421-340-00	(US,Canadian,AEP,UK)...MICRO INDUCTOR 10UH
L202	1-421-400-01	(AEP,HK)...MICRO INDUCTOR 10UH
L201	1-421-580-01	(US)...TRANSFORMER, LINE FILTER
L301	1-408-117-00	(US,AEP,UK)...MICRO INDUCTOR 10UH
L302	1-408-117-00	(US,AEP,UK)...MICRO INDUCTOR 10UH
L303	1-408-117-00	(US,AEP,UK)...MICRO INDUCTOR 10UH
L701	1-408-117-00	MICRO INDUCTOR 10UH
L702	1-408-117-00	MICRO INDUCTOR 10UH
L703	1-408-117-00	MICRO INDUCTOR 10UH
L751	1-408-117-00	(US,AEP,UK)...MICRO INDUCTOR 10UH
L752	1-408-117-00	(US,AEP,UK)...MICRO INDUCTOR 10UH
L753	1-408-117-00	(US,AEP,UK)...MICRO INDUCTOR 10UH
M53	1-422-197-13	COIL (SLED)
M651	X-4902-019-1	MOTOR ASSY, CHUCKING
M652	A-4608-303-A	MOTOR ASSY, LOADING
Q551	1-532-085-00	(Canadian)...LINK, 1K
Q301	8-769-163-00	TRANSISTOR 2SK152-3
Q401	8-769-163-00	TRANSISTOR 2SK152-3
Q501	8-729-117-54	TRANSISTOR 2SA1175
Q502	8-729-100-13	TRANSISTOR 2SC2001
Q503	8-729-177-44	TRANSISTOR 2SD774-5
Q504	8-729-374-02	TRANSISTOR 2SB740
Q505	8-729-177-44	TRANSISTOR 2SD774-5
Q506	8-729-374-02	TRANSISTOR 2SB740
Q507	8-729-177-44	TRANSISTOR 2SD774-5
Q508	8-729-374-02	TRANSISTOR 2SB740
Q509	8-729-177-44	TRANSISTOR 2SD774-5
Q510	8-729-374-02	TRANSISTOR 2SB740
Q511	8-729-900-74	TRANSISTOR DTC143TS
Q512	8-729-900-74	TRANSISTOR DTC143TS
Q513	8-729-900-89	TRANSISTOR DTC144ES
Q601	8-729-900-80	TRANSISTOR DTC114ES
Q701	8-729-117-54	TRANSISTOR 2SA1175
Q702	8-729-178-55	TRANSISTOR 2SC2785
Q705	8-729-901-57	TRANSISTOR DTC143XS
Q706	8-729-178-55	TRANSISTOR 2SC2785
Q707	8-729-900-80	TRANSISTOR DTC114ES
Q801	8-729-900-80	TRANSISTOR DTC114ES
Q802	8-729-900-80	TRANSISTOR DTC114ES
Q803	8-729-900-80	TRANSISTOR DTC114ES
Q804	8-729-900-80	TRANSISTOR DTC114ES
Q805	8-729-900-80	TRANSISTOR DTC114ES
Q806	8-729-900-80	TRANSISTOR DTC114ES
Q901	8-729-127-53	TRANSISTOR 2SC2275-P
Q902	8-729-167-62	TRANSISTOR 2SC2676
Q903	8-729-113-82	TRANSISTOR 2SA1138
Q904	8-729-167-62	TRANSISTOR 2SC2676
Q951	8-729-118-53	TRANSISTOR 2SA985-P
Q952	8-729-113-82	TRANSISTOR 2SA1138
Q953	8-729-167-62	TRANSISTOR 2SC2676
Q954	8-729-113-82	TRANSISTOR 2SA1138
Q991	8-729-178-55	TRANSISTOR 2SC2785
Q992	8-729-177-44	TRANSISTOR 2SD774-5

ELECTRICAL PARTS

Ref.No.	Part No.	Description			
R151	1-247-831-00	CARBON	1K	5%	1/6W
R152	1-247-831-00	CARBON	1K	5%	1/6W
R153	1-247-831-00	CARBON	1K	5%	1/6W
R154	1-247-831-00	CARBON	1K	5%	1/6W
R155	1-247-831-00	CARBON	1K	5%	1/6W
R156	1-247-831-00	CARBON	1K	5%	1/6W
R157	1-247-887-00	CARBON	33K	5%	1/6W
R158	1-247-887-00	CARBON	33K	5%	1/6W
R159	1-247-887-00	CARBON	33K	5%	1/6W
R160	1-247-887-00	CARBON	33K	5%	1/6W
R301	1-214-880-00	METAL	4.7K	1%	1/2W
R302	1-214-737-00	METAL	2.2K	1%	1/4W
R303	1-214-878-00	METAL	3.9K	1%	1/2W
R304	1-214-888-00	METAL	10K	1%	1/2W
R305	1-214-729-00	METAL	1K	1%	1/4W
R306	1-214-729-00	METAL	1K	1%	1/4W
R307	1-214-875-00	METAL	3K	1%	1/2W
R308	1-214-870-00	METAL	1.8K	1%	1/2W
R309	1-214-845-11	METAL	160	1%	1/2W
R310	1-214-880-00	METAL	4.7K	1%	1/2W
R311	1-214-929-00	METAL	470K	1%	1/2W
R312	1-214-924-00	METAL	300K	1%	1/2W
R313	1-214-840-00	METAL	100	1%	1/2W
R314	1-214-765-00	METAL	33K	1%	1/4W
R331	1-214-852-00	METAL	330	1%	1/2W
R332	1-214-852-00	METAL	330	1%	1/2W
R333	1-214-723-00	METAL	560	1%	1/4W
R334	1-214-763-00	METAL	27K	1%	1/4W
R335	1-214-745-00	METAL	4.7K	1%	1/4W
R336	1-214-767-00	METAL	39K	1%	1/4W
R337	1-214-713-00	METAL	220	1%	1/4W
R351	1-247-871-00	CARBON	47K	5%	1/6W
R353	1-214-733-00	METAL	1.5K	1%	1/4W
R354	1-214-903-00	METAL	39K	1%	1/2W
R355	1-214-705-00	(Canadian,E)...METAL	100	1%	1/4W
R356	1-214-705-00	(Canadian,E)...METAL	100	1%	1/4W
R357	1-247-807-00	CARBON	100	5%	1/6W
R371	1-214-913-00	METAL	100K	1%	1/2W
R372	1-214-870-00	METAL	1.8K	1%	1/2W
R373	1-214-743-00	METAL	3.9K	1%	1/4W
R374	1-214-736-00	METAL	2K	1%	1/4W
R375	1-214-734-00	METAL	1.6K	1%	1/4W
R376	1-214-878-00	METAL	3.9K	1%	1/2W
R377	1-214-742-00	METAL	3.6K	1%	1/4W
R378	1-214-736-00	METAL	2K	1%	1/4W
R379	1-214-736-00	METAL	2K	1%	1/4W
R380	1-214-878-00	METAL	3.9K	1%	1/2W
R381	1-214-743-00	METAL	3.9K	1%	1/4W
R382	1-214-736-00	METAL	2K	1%	1/4W
R383	1-214-734-00	METAL	1.6K	1%	1/4W
R384	1-214-870-00	METAL	1.8K	1%	1/2W
R385	1-214-907-00	METAL	56K	1%	1/2W
R386	1-214-907-00	METAL	56K	1%	1/2W
R502	1-247-883-00	CARBON	150K	5%	1/6W
R503	1-247-899-00	CARBON	680K	5%	1/6W
R504	1-247-845-00	CARBON	3.9K	5%	1/6W
R505	1-247-815-00	CARBON	220	5%	1/6W

The components identified by shading and mark **A** are critical for safety. Replace only with part number specified.

Les composants identifiés par une trame et une marque **A** sont critiques pour la sécurité. Ne les remplacer que par une pièce portant le numéro spécifié.

ELECTRICAL PARTS

Ref.No.	Part No.	Description			
R506	1-247-855-00	CARBON	10K	5%	1/6W
R507	1-247-859-00	CARBON	15K	5%	1/6W
R508	1-247-831-00	CARBON	1K	5%	1/6W
R509	1-247-895-00	CARBON	470K	5%	1/6W
R510	1-249-421-11	CARBON	2.2K	5%	1/6W
R511	1-247-855-00	CARBON	10K	5%	1/6W
R512	1-247-855-00	CARBON	10K	5%	1/6W
R513	1-247-863-00	CARBON	22K	5%	1/6W
R514	1-247-859-00	CARBON	15K	5%	1/6W
R515	1-247-841-00	CARBON	2.7K	5%	1/6W
R516	1-247-869-00	CARBON	39K	5%	1/6W
R519	1-247-843-00	CARBON	3.3K	5%	1/6W
R531	1-247-903-00	CARBON	1M	5%	1/6W
R532	1-247-807-00	CARBON	100	5%	1/6W
R533	1-247-831-00	CARBON	1K	5%	1/6W
R534	1-247-869-00	CARBON	39K	5%	1/6W
R535	1-247-865-00	CARBON	27K	5%	1/6W
R536	1-247-863-00	CARBON	22K	5%	1/6W
R538	1-247-837-00	CARBON	1.2K	5%	1/6W
R539	1-247-879-00	CARBON	100K	5%	1/6W
R540	1-247-855-00	CARBON	10K	5%	1/6W
R541	1-247-859-00	CARBON	15K	5%	1/6W
R542	1-247-831-00	CARBON	1K	5%	1/6W
R543	1-247-851-00	CARBON	6.8K	5%	1/6W
R544	1-247-867-00	CARBON	33K	5%	1/6W
R545	1-247-863-00	CARBON	22K	5%	1/6W
R551	1-247-807-00	CARBON	100	5%	1/6W
R552	1-247-847-00	CARBON	4.7K	5%	1/6W
R553	1-247-819-00	CARBON	330	5%	1/6W
R554	1-247-865-00	CARBON	27K	5%	1/6W
R555	1-247-851-00	CARBON	6.8K	5%	1/6W
R556	1-247-863-00	CARBON	22K	5%	1/6W
R561	1-247-864-00	CARBON	24K	5%	1/6W
R562	1-247-851-00	CARBON	6.8K	5%	1/6W
R563	1-247-855-00	CARBON	10K	5%	1/6W
R564	1-247-871-00	CARBON	47K	5%	1/6W
R571	1-247-885-00	CARBON	180K	5%	1/6W
R572	1-247-881-00	CARBON	120K	5%	1/6W
R573	1-247-881-00	CARBON	120K	5%	1/6W
R574	1-247-885-00	CARBON	180K	5%	1/6W
R601	1-247-843-00	CARBON	3.3K	5%	1/6W
R602	1-215-441-00	METAL	6.8K	1%	1/6W
R603	1-247-856-00	CARBON	11K	5%	1/6W
R604	1-215-441-00	METAL	6.8K	1%	1/6W
R605	1-247-903-00	CARBON	1M	5%	1/6W
R606	1-247-856-00	CARBON	11K	5%	1/6W
R607	1-247-863-00	CARBON	22K	5%	1/6W
R608	1-215-453-00	METAL	22K	1%	1/6W
R609	1-247-887-00	CARBON	220K	5%	1/6W
R610	1-247-869-00	CARBON	39K	5%	1/6W
R611	1-215-449-00	METAL	15K	1%	1/6W
R621	1-247-879-00	CARBON	100K	5%	1/6W
R622	1-247-879-00	CARBON	100K	5%	1/6W
R623	1-247-831-00	CARBON	1K	5%	1/6W

ELECTRICAL PARTS

Ref.No.	Part No.	Description			
R624	1-247-879-00	CARBON	100K	5%	1/6W
R625	1-247-851-00	CARBON	6.8K	5%	1/6W
R626	1-215-453-00	METAL	22K	1%	1/6W
R627	1-247-867-00	CARBON	33K	5%	1/6W
R628	1-247-857-00	CARBON	12K	5%	1/6W
R629	1-215-453-00	METAL	22K	1%	1/6W
R630	1-247-841-00	CARBON	2.7K	5%	1/6W
R631	1-247-847-00	CARBON	4.7K	5%	1/6W
R632	1-247-863-00	CARBON	22K	5%	1/6W
R633	1-247-855-00	CARBON	10K	5%	1/6W
R634	1-247-855-00	CARBON	10K	5%	1/6W
R702	1-247-879-00	CARBON	100K	5%	1/6W
R703	1-247-903-00	CARBON	1M	5%	1/6W
R705	1-247-847-00	CARBON	4.7K	5%	1/6W
R706	1-247-855-00	CARBON	10K	5%	1/6W
R707	1-247-863-00	CARBON	22K	5%	1/6W
R708	1-247-903-00	CARBON	1M	5%	1/6W
R709	1-247-842-00	CARBON	3K	5%	1/6W
R710	1-247-863-00	CARBON	22K	5%	1/6W
R711	1-247-863-00	CARBON	22K	5%	1/6W
R715	1-247-855-00	CARBON	10K	5%	1/6W
R720	1-247-809-00	(US,AEP,UK)...CARBON	120	5%	1/6W
R801	1-247-811-00	CARBON	150	5%	1/6W
R802	1-247-813-00	CARBON	180	5%	1/6W
R803	1-247-807-00	CARBON	100	5%	1/6W
R804	1-247-815-00	CARBON	220	5%	1/6W
R805	1-247-819-00	CARBON	330	5%	1/6W
R806	1-247-811-00	CARBON	150	5%	1/6W
R807	1-247-811-00	CARBON	150	5%	1/6W
R851	1-247-775-00	CARBON	4.7	5%	1/6W
R852	1-214-784-00	METAL	200K	1%	1/4W
R853	1-247-863-00	CARBON	22K	5%	1/6W
R854	1-247-799-00	CARBON	47	5%	1/6W
R900	1-214-936-00	(US,AEP,UK)...FUSE	32	5%	1/2W
R902	1-214-723-00	METAL	560	1%	1/4W
R903	1-214-771-00	METAL	56K	1%	1/4W
R904	1-214-741-00	METAL	3.3K	1%	1/4W
R905	1-214-863-00	METAL	910	1%	1/2W
R906	1-214-866-00	METAL	1.2K	1%	1/2W
R907	1-214-705-00	METAL	100	1%	1/4W
R909	1-214-852-00	METAL	330	1%	1/2W
R981	1-212-865-00	(US,Canadian,AEP,UK)...FUSE	4.7	5%	1/4W
R981	1-214-824-11	(E)... METAL	22	1%	1/2W
R992	1-247-835-00	CARBON	1.5K	5%	1/6W
R993	1-247-831-00	CARBON	1K	5%	1/6W
R994	1-247-843-00	CARBON	3.3K	5%	1/6W
R995	1-247-846-00	CARBON	4.3K	5%	1/6W
R996	1-247-855-00	CARBON	10K	5%	1/6W
R997	1-247-853-00	CARBON	8.2K	5%	1/6W
R998	1-247-885-00	CARBON	180K	5%	1/6W
R999	1-247-807-00	CARBON	100	5%	1/6W

The components identified by shading and mark **A** are critical for safety. Replace only with part number specified.

Les composants identifiés par une trame et une marque **A** sont critiques pour la sécurité. Ne les remplacer que par une pièce portant le numéro spécifié.

ELECTRICAL PARTS

Ref.No.	Part No.	Description
RV301	1-230-674-11	RES, VAR, CARBON 20K/20K
RV401	1-230-674-11	RES, VAR, CARBON 20K/20K
RV501	1-226-703-00	RES, ADJ, METAL GLAZE 10K
RV502	1-226-703-00	RES, ADJ, METAL GLAZE 10K
RV601	1-230-522-11	RES, ADJ, METAL GLAZE 4.7K
RY351	1-515-547-11	RELAY
RY352	1-515-547-11	RELAY
S301	1-554-421-00	SWITCH, PUSH (POWER)
S301	1-554-421-00	SWITCH, SLIDE (TIMER)
S401	1-570-100-11	SWITCH, SLIDE (PLAY MODE)
S651	1-554-205-00	SWITCH, PUSH (CHUCKING DET)
S652	1-554-205-00	SWITCH, PUSH (DISC TABLE POSITIONDET)
S653	1-553-636-00	SWITCH, MICRO (MOTOR)
S654	1-553-636-00	SWITCH, MICRO (CHUCKING)
S655	1-554-205-00	SWITCH, PUSH (CHUCKING)
S656	1-554-205-00	SWITCH, PUSH (CHUCKING)
S801	1-554-303-00	SWITCH, KEY BOARD (1)
S802	1-554-303-00	SWITCH, KEY BOARD (2)
S803	1-554-303-00	SWITCH, KEY BOARD (3)
S804	1-554-303-00	SWITCH, KEY BOARD (4)
S805	1-554-303-00	SWITCH, KEY BOARD (5)
S806	1-554-303-00	SWITCH, KEY BOARD (6)
S807	1-554-303-00	SWITCH, KEY BOARD (7)
S808	1-554-303-00	SWITCH, KEY BOARD (8)
S809	1-554-303-00	SWITCH, KEY BOARD (9)
S810	1-554-303-00	SWITCH, KEY BOARD (10)
S811	1-554-303-00	SWITCH, KEY BOARD (11)
S812	1-554-303-00	SWITCH, KEY BOARD (12)
S813	1-554-303-00	SWITCH, KEY BOARD (13)
S814	1-554-303-00	SWITCH, KEY BOARD (14)
S815	1-554-303-00	SWITCH, KEY BOARD (15)
S816	1-554-303-00	SWITCH, KEY BOARD (16)
S817	1-554-303-00	SWITCH, KEY BOARD (17)
S818	1-554-303-00	SWITCH, KEY BOARD (18)
S819	1-554-303-00	SWITCH, KEY BOARD (19)
S820	1-554-303-00	SWITCH, KEY BOARD (20)
S821	1-554-303-00	SWITCH, KEY BOARD (+10)
S822	1-554-303-00	SWITCH, KEY BOARD (0)
S823	1-554-303-00	SWITCH, KEY BOARD (CHECK)
S824	1-554-303-00	SWITCH, KEY BOARD (CLEAR)
S825	1-554-303-00	SWITCH, KEY BOARD (▶ PLAY)
S826	1-554-303-00	SWITCH, KEY BOARD (■ PAUSE)
S827	1-554-303-00	SWITCH, KEY BOARD (■ STOP)
S828	1-570-101-11	SWITCH, KEY BOARD (PROGRAM)
S829	1-570-101-31	SWITCH, KEY BOARD (SINGLE)
S830	1-570-101-21	SWITCH, KEY BOARD (CONTINUE)
S831	1-554-303-00	SWITCH, KEY BOARD (⏮)
S832	1-554-303-00	SWITCH, KEY BOARD (⏪)
S833	1-554-303-00	SWITCH, KEY BOARD (⏩)
S834	1-554-303-00	SWITCH, KEY BOARD (⏭)
S835	1-554-303-00	SWITCH, KEY BOARD (⏮)
S836	1-554-303-00	SWITCH, KEY BOARD (⏭)
S841	1-554-303-00	SWITCH, KEY BOARD (REPEAT)
S842	1-554-303-00	SWITCH, KEY BOARD (A-B)
S843	1-554-303-00	SWITCH, KEY BOARD (TIME)

ELECTRICAL PARTS

Ref.No.	Part No.	Description
S844	1-554-303-00	SWITCH, KEY BOARD (AUTO DELAY)
S845	1-554-303-00	SWITCH, KEY BOARD (SHUFFLE PLAY)
S846	1-554-303-00	SWITCH, KEY BOARD (OPEN/CLOSE)
T351	1-406-123-11	COIL (OSC)
T701	1-426-212-11	COIL (RF)
T901	1-448-023-11	(E).....TRANSFORMER, POWER
	1-448-022-11	(Canadian)...TRANSFORMER, POWER
	1-448-254-11	(US).....TRANSFORMER, POWER
	1-448-021-11	(AEP,UK)....TRANSFORMER, POWER
VS901	1-552-963-00	(E)...SWITCH, POWER/VOLTAGE SELECT
X351	1-567-336-11	VIBRATOR, CRYSTAL
X701	1-527-532-00	OSCILLATOR, CERAMIC

ACCESSORY & PACKING MATERIAL

Part No.	Description
1-528-027-11	BATTERY, NEW SUPER (SUM-3)(NS)
1-551-315-00	CORD, CONNECTION
1-564-085-00	(UK)....PLUG, AC
3-304-973-00	(US,Canadian,AEP,UK)...SHEET, PROTECTION
3-536-825-00	BAG, PROTECTING
3-701-630-00	BAG, POLYETHYLENE
3-703-390-01	INSTRUCTION (US)
3-760-188-11	(E).....MANUAL, INSTRUCTION
3-760-188-11	(AEP,UK)....MANUAL, INSTRUCTION
3-760-188-42	(AEP).....MANUAL, INSTRUCTION
3-760-403-31	(Canadian)...MANUAL, INSTRUCTION
*3-795-629-11	INSTRUCTION
4-884-695-03	CLEANER, DISK
4-907-610-01	JOINT
4-908-440-51	(AEP,UK,E).....INDIVIDUAL CARTON
4-908-440-61	(US,Canadian)...INDIVIDUAL CARTON
4-908-441-01	CUSHION (RIGHT), UPPER
4-908-442-01	CUSHION (LEFT), UPPER
4-908-443-01	CUSHION, LOWER
4-908-602-01	HOLDER, COMMANDER

The components identified by shading and mark A are critical for safety. Replace only with part number specified.	Les composants identifiés par une trame et une marque A sont critiques pour la sécurité. Ne les remplacer que par une pièce portant le numéro spécifié.
--------------------------------------------------------------------------------------------------------------------------	----------------------------------------------------------------------------------------------------------------------------------------------------------------