

CDP-490

SERVICE MANUAL

*Canadian Model
AEP Model*

Model CDP-490 is almost same as CDP-590.
As only the difference from CDP-590 is described in this manual,
please refer to the CDP-590 service manual for the other sections.

● SECTION 6 EXPLODED VIEWS AND PARTS LIST

Page on CDP-590 Service Manual	No.	Part No.	Description
21	1	4-933-208-31	(AEP)... PANEL, LOADING
	1	4-933-208-41	(Canadian)... PANEL, LOADING
	4	*3-703-244-00	(Canadian)... BUSHING(2104), CORD
	5	*4-933-201-51	(Canadian)... PANEL, BACK
	5	*4-933-201-61	(AEP)... PANEL, BACK
	8	X-4885-950-1	(Canadian)... FOOT ASSY
	901	*A-4617-494-A	(Canadian)... MOUNTED PCB, MAIN
	907	△1-575-105-11	(Canadian)... CORD, POWER
22	T701	△1-449-921-11	(Canadian)... TRANSFORMER, POWER
	51	X-4933-205-1	(Canadian)... PANEL ASSY, FRONT
	51	A-4604-399-A	(AEP)... PANEL ASSY, FRONT

● SECTION 7 ELECTRICAL PARTS LIST ACCESSORY & PACKING MATERIAL

Page on CDP-590 Service Manual	Part No.	Description
27	3-750-792-11	(Canadian)... MANUAL, INSTRUCTION
	*4-933-231-21	INDIVIDUAL CARTON

Note: The CDP-490 has not been supplied with remote commander.

COMPACT DISC PLAYER
SONY®



9-955-801-11

Sony Corporation
Audio Group

English
90D1850-1
Printed in Japan
©1990.4
Published by Customer Relations and Service Group.

CDP-590

SERVICE MANUAL

US Model
AEP Model
E Model
Australian Model

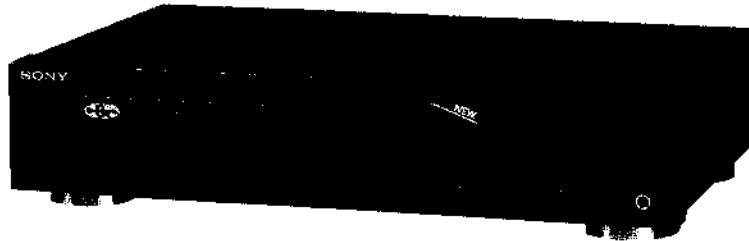

SPECIFICATIONS

Compact disc player

Frequency response	2Hz - 20 kHz \pm 0.5 dB
Signal to noise ratio	More than 100 dB
Dynamic range	More than 92 dB
Harmonic distortion	Less than 0.008%
Channel separation	More than 95 dB

Outputs

LINE OUT (phono jacks)	Output level 2 V (at 50 kilohms) Load impedance over 10 kilohms
PHONES (stereo phone jack)	Output level max. 10 mW Load impedance 32 ohms

General

Power requirements	120 V AC, 60Hz
Power consumption	11W
Dimensions (approx., including projections)	430 \times 100 \times 280 mm (w/h/d) (17 \times 4 \times 11 $\frac{1}{8}$ inches)
Weight (approx.)	3.5 kg (7 lbs 12 oz)

Supplied accessories

Audio cord	1 (2 phono plugs - 2 phono plugs)
Remote commander	1
R6 (size AA) batteries	2

Remote commander

Remote control system	Infrared control
Power requirements	3 V DC with two R6 (size AA) batteries
Dimensions	Approx. 43 \times 20 \times 175 mm (w/h/d) (1 $\frac{3}{4}$ \times 1 $\frac{9}{16}$ \times 7 inches)
Weight	Approx. 105 g (4 oz) Including batteries

Design and specifications subject to change without notice.

SAFETY-RELATED COMPONENT WARNING!!

COMPONENTS IDENTIFIED BY MARK Δ OR DOTTED LINE WITH MARK Δ ON THE SCHEMATIC DIAGRAMS AND IN THE PARTS LIST ARE CRITICAL TO SAFE OPERATION. REPLACE THESE COMPONENTS WITH SONY PARTS WHOSE PART NUMBERS APPEAR AS SHOWN IN THIS MANUAL OR IN SUPPLEMENTS PUBLISHED BY SONY.

ATTENTION AU COMPOSANT AYANT RAPPORT À LA SÉCURITÉ!

LES COMPOSANTS IDENTIFIÉS PAR UNE MARQUE Δ SUR LES DIAGRAMMES SCHEMATIQUES ET LA LISTE DES PIÈCES SONT CRITIQUES POUR LA SÉCURITÉ DE FONCTIONNEMENT. NE REMPLACER CES COMPOSANTS QUE PAR DES PIÈCES SONY DONT LES NUMÉROS SONT DONNÉS DANS CE MANUEL OU DANS LES SUPPLÉMENTS PUBLIÉS PAR SONY.



COMPACT DISC PLAYER
SONY

TABLE OF CONTENTS

<u>Section</u>	<u>Title</u>	<u>Page</u>
Specifications		1
1. GENERAL		4
2. IC FUNCTION DESCRIPTION		5
3. DISSASSEMBLY OF BASE UNIT		6
4. ADJUSTMENTS		7
5. DIAGRAMS		11
5-1.	Waveforms	11
5-2.	Printed Wiring Boards	12
5-3.	Schematic Diagram	15
5-4.	IC Block Diagrams	19
6. EXPLODED VIEWS		21
6-1.	Cabinet Section	21
6-2.	Front Panel Section	22
6-3.	MD Section-1(CDM 14-5BD1)	23
6-4.	MD Section-2(BU-5BD1)	24
7. ELECTRICAL PARTS LIST		25

SAFETY CHECK-OUT

After correcting the original service problem, perform the following safety check before releasing the set to the customer:

Check the antenna terminals, metal trim, "metallized" knobs, screws, and all other exposed metal parts for AC leakage. Check leakage as described below.

LEAKAGE TEST

The AC leakage from any exposed metal part to earth ground and from all exposed metal parts to any exposed metal part having a return to chassis, must not exceed 0.5 mA (500 microamperes). Leakage current can be measured by any one of three methods.

1. A commercial leakage tester, such as the Simpson 229 or RCA WT-540A. Follow the manufacturers' instructions to use these instruments.
2. A battery-operated AC milliammeter. The Data Precision 245 digital multimeter is suitable for this job.

3. Measuring the voltage drop across a resistor by means of a VOM or battery-operated AC voltmeter. The "limit" indication is 0.75 V, so analog meters must have an accurate low-voltage scale. The Simpson 250 and Sanwa SH-63Trd are examples of a passive VOM that is suitable. Nearly all battery operated digital multimeters that have a 2V AC range are suitable. (See Fig. A)

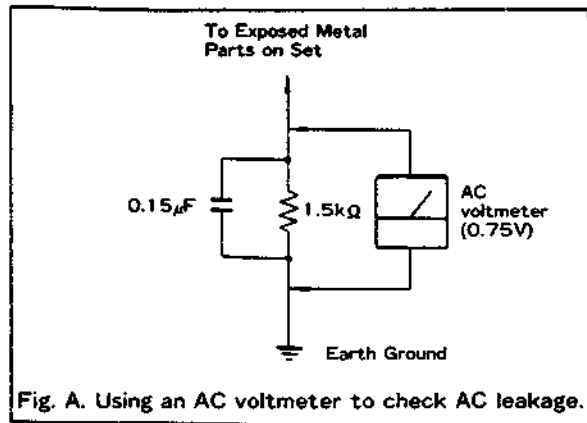

Fig. A. Using an AC voltmeter to check AC leakage.

SERVICING NOTE

NOTES ON HANDLING THE OPTICAL PICK-UP BLOCK OR BASE UNIT

The laser diode in the optical pick-up block may suffer electrostatic breakdown because of the potential difference generated by the charged electrostatic load, etc. on clothing and the human body.

During repair, pay attention to electrostatic breakdown and also use the procedure in the printed matter which is included in the repair parts.

The flexible board is easily damaged and should be handled with care.

CAUTION

Use of controls or adjustments or performance of procedures other than those specified herein may result in hazardous radiation exposure.

NOTES ON LASER DIODE EMISSION CHECK

The laser beam on this model is concentrated so as to be focused on the disc reflective surface by the objective lens in the optical pick-up block. Therefore, when checking the laser diode emission, observe from more than 30 cm away from the objective lens.

PROTECTION OF EYES FROM LASER BEAM DURING SERVICING

This set employs a laser. Therefore, be sure to follow carefully the instructions below when servicing.

CAUTION

Use of controls or adjustments or performance of procedures other than those specified herein may result in hazardous radiation exposure.

1. Laser Diode Properties

- Material: GaAlAs
- Wavelength: 780 nm
- Emission Duration: continuous
- Laser Output: max. 44.6 μ W*

* This output is the value measured at a distance of about 200 mm from the objective lens surface on the Optical Pick-up Block.

2. During service, do not take the Optical Pick-up Block apart, and do not adjust the APC circuit. If there is a breakdown in the APC circuit (including laser diode), replace the entire Optical Pick-up Block (including APC board).

BESKYTTELSE AF ØJNE MOD LASERSTRÅLING UNDER SERVICE

I dette apparat anvendes laserlys. Derfor skal nedenstående instruktioner nøje følges under service.

Følg iverigt instruktionerne i servicemanualen.

ADVARSEL!!

Under service må øjnene ikke komme nær objektiv-linsen på den optiske pick-up enhed. I tilfælde af at det er nødvendigt at kontrollere udsendelsen af laserlys, skal det ske i en afstand af mere end 25 cm fra den optiske pick-up.

1. Laser-dioe data

- Materiale: GaAlAs
- Bølgelængde: 780 nm
- Udstråling: Kontinuerlig
- Laseroutput: Max. 0,4 mW*

* Målt i 1,6 mm afstand fra overfladen af objektiv-linsen på den optiske pick-up enhed.

- Klassifikation: Klasse IIIb.

2. Adskil aldrig den optiske pick-up enhed under service, og juster ikke APC kredsløbet (Automatic Power Control). Hvis APC kredsløbet (incl. laser-dioden) bryder ned, skal hele den optiske pick-up enhed (incl. APC printkortet) udskiftes.

SECTION 1 GENERAL

Location of Controls

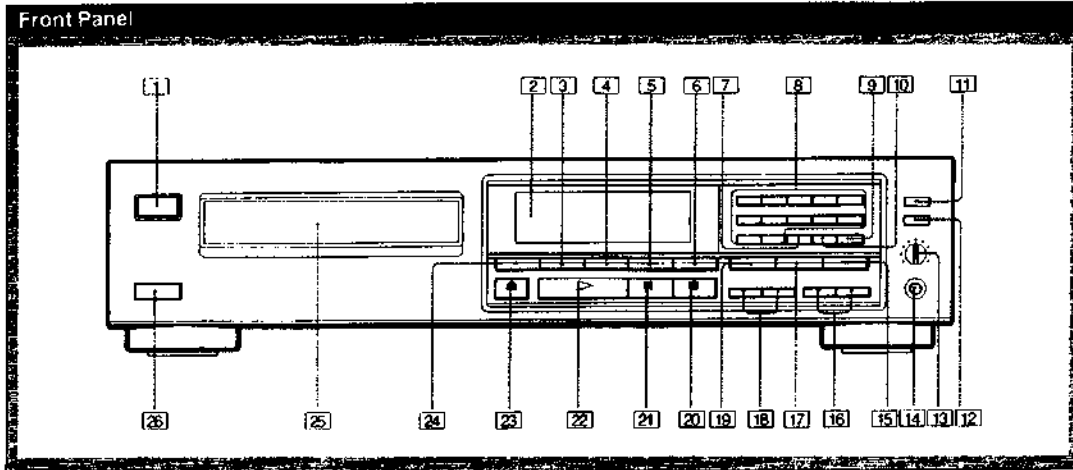

Refer to the pages indicated in ● for details.

- | | |
|--|---|
| <ul style="list-style-type: none"> 1 POWER switch ● 2 Display window 3 TIME button ● 4 AUTO SPACE button ● 5 REPEAT button ● 6 FADER (FADE IN/FADE OUT) button ● 7 CHECK (program check) button ● 8 Numeric buttons ●, ●, ● 9 > 12 (over 12) button ● 10 CLEAR (program clear) button ● 11 EDIT/TIME FADE button ●, ● 12 TIME SET button ●, ● 13 PHONE LEVEL control 14 PHONES jack | <ul style="list-style-type: none"> 15 PROGRAM button ● 16 ◀▶ (manual search) buttons ●, ● 17 SHUFFLE button ● 18 ◀▶▶ (AMS*/RMS**) buttons ●, ● 19 CONTINUE button ● 20 ■ (stop) button ● 21 (pause) button ● 22 ▶ (play) button ● 23 ▲ (open/close) button ● 24 PEAK SEARCH button ● (except for AEP model) 25 Disc tray ● 26 Remote sensor ● <p>* AMS is the abbreviation of Automatic Music Sensor.
** RMS is the abbreviation of Random Music Sensor.</p> |
|--|---|

Remote Commander

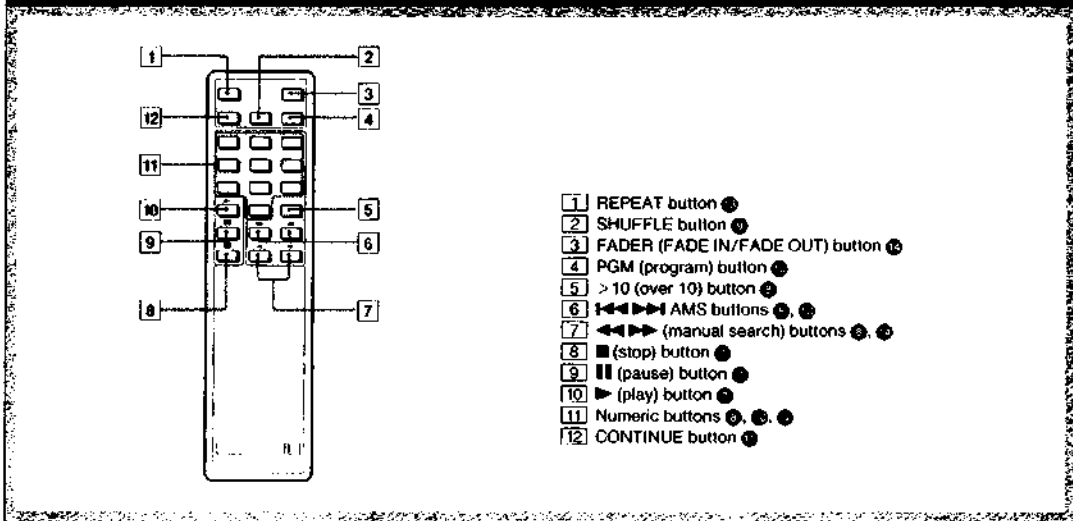

- 1 REPEAT button ●
- 2 SHUFFLE button ●
- 3 FADER (FADE IN/FADE OUT) button ●
- 4 PGM (program) button ●
- 5 > 10 (over 10) button ●
- 6 ◀▶▶ AMS buttons ●, ●
- 7 ◀▶▶ (manual search) buttons ●, ●
- 8 ■ (stop) button ●
- 9 || (pause) button ●
- 10 ▶ (play) button ●
- 11 Numeric buttons ●, ●, ●
- 12 CONTINUE button ●

SECTION 2 IC FUNCTION DESCRIPTION

IC101 (CXA1372Q) PIN DESIGNATION

Pin No.	Pin Name	I/O	Pin Description
1	VC		GND when two (\pm) dual power supplies are in use, or the center voltage (2.5 V) when a single power supply is in use.
2	FGD	I	Time constants for gain switching in normal mode/down mode and for focus gain are connected between the FGD and FS3 pins.
3	FS3	I	
4	FLB	I	The capacitor for low frequency boost in the focus servo loop is connected.
5	FEO	O	Focus drive output
6	FE-	I	Inverted input to focus amplifier
7	SRCH	I	Time constants to generate the focus search waveform are connected.
8	TGU	I	Time constants for gain switching in normal mode/up mode and for tracking gain are connected between TGU pin and TG2 pin.
9	TG2	I	
10	AVCC		Analog power supply (5 V when \pm dual power supplies are in use, 5 V when a single power supply is in use.)
11	TAO	O	Tracking drive output
12	TA-	I	Inverted input to tracking amplifier
13	SL+	I	Non-inverted input to sled amplifier
14	SLO	O	Sled drive output
15	SL-	I	Non-inverted input to sled amplifier
16	ESET	I	The 610-k Ω phase compensator resistor is connected to this pin.
17	ISET	I	The current setting resistor is connected to this pin.
18	SSTOP	I	The limit switch is connected to this pin.
19	AVEE		Analog power supply (-5V when \pm dual power supplies are in use, or GND when a single power supply is in use.)
20	DIRC	I	Direct control pin.
21	LOCK	I	Sled run-away prevention circuit operates when this signal is "L".
22	CLK	I	Serial data transfer clock input that is supplied from CPU (or DSP).
23	XLT	I	Latch input from CPU (or DSP).
24	DATA	I	Serial data input from CPU (or DSP).
25	XRST	I	System reset. "L" to reset.
26	C.OUT	O	Output to tracking counter.
27	SENS	O	SENS output
28	DGND		Digital ground (GND). (GND when \pm dual power supplies are in use. GND when a single power supply is in use.)
29	MIRR	O	Mirror output.
30	DFCT	O	Defect output. "H" when defective.
31	ASY	I	Auto-assymetry control input.
32	EFM	O	EFM comparator output.
33	FOK	O	Focus OK.
34	CC2	I	Defect-bottom-hold input (input by capacitive coupling).
35	CC1	O	Defect-bottom-hold output.
36	DVCC		Digital power supply (+5 V when \pm dual power supplies in use. +5 V when a single power supply is in use.)
37	CB	I	The defect-bottom-hold capacitor is connected to this pin.
38	CP	I	The mirror hold capacitor is connected to this pin.
39	RF1	I	RF signal input (input by capacitive coupling).
40	RF0	I	RF signal input (input by DC coupling).
41	DVEE		Digital power supply (-5 V when \pm dual power supplis are in use. GND when a single power supply is in use.)
42	TZC	I	Tracking zero cross comparator input.
43	TE	I	Tracking error input.
44	TDFCT	I	The defect prevention hold capacitor is connected to this pin.
45	ATSC	I	Anti-shock input.
46	FZC	I	Focus zero-cross comparator input.
47	FE	I	Focus error input.
48	FDFCT	I	The defect prevention hold capacitor is connected to this pin.

SECTION 3 DISSASSEMBLY OF BASE UNIT

Note:

Follow the disassembly procedure in the numerical order given.

- ① Turn the cam to the direction of arrow (Counter clock wise) by minus screw driver.
- ② Take off the disc table.
- ③ Remove the bracket yoke.
- ④ Remove the MD (BU-5BD1) to the direction of arrow.

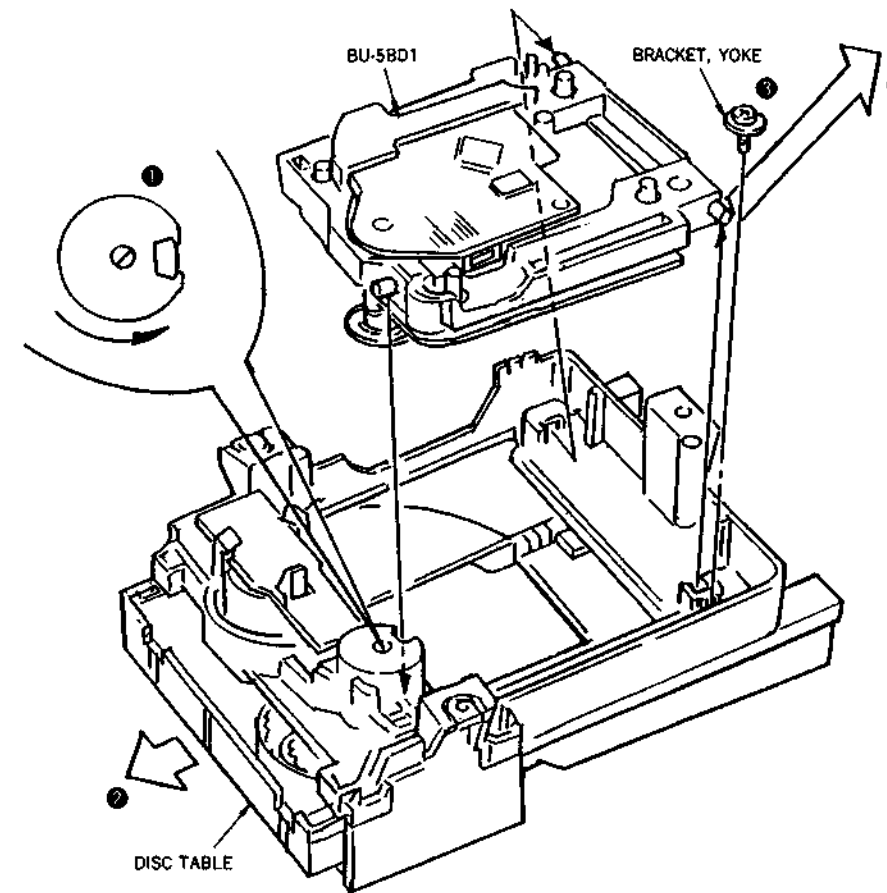

ELECT

1. Perform
2. Use Y
- wise
3. Use t

RF LE

This
Optical
Procedu

1. Conn
- TP (
2. Turn
3. Put t
4. Conf
- Optim
- clear

RF L

E-F B

This
Optical
Procedu

1. Conn
- and
2. Grou
3. Turn

SECTION 3 DISSASSEMBLY OF BASE UNIT

Note:

Follow the disassembly procedure in the numerical order given.

- ① Turn the cam to the direction of arrow (Counter clock wise) by minus screw driver.
- ② Take off the disc table.
- ③ Remove the bracket yoke.
- ④ Remove the MD (BU-5BD1) to the direction of arrow.

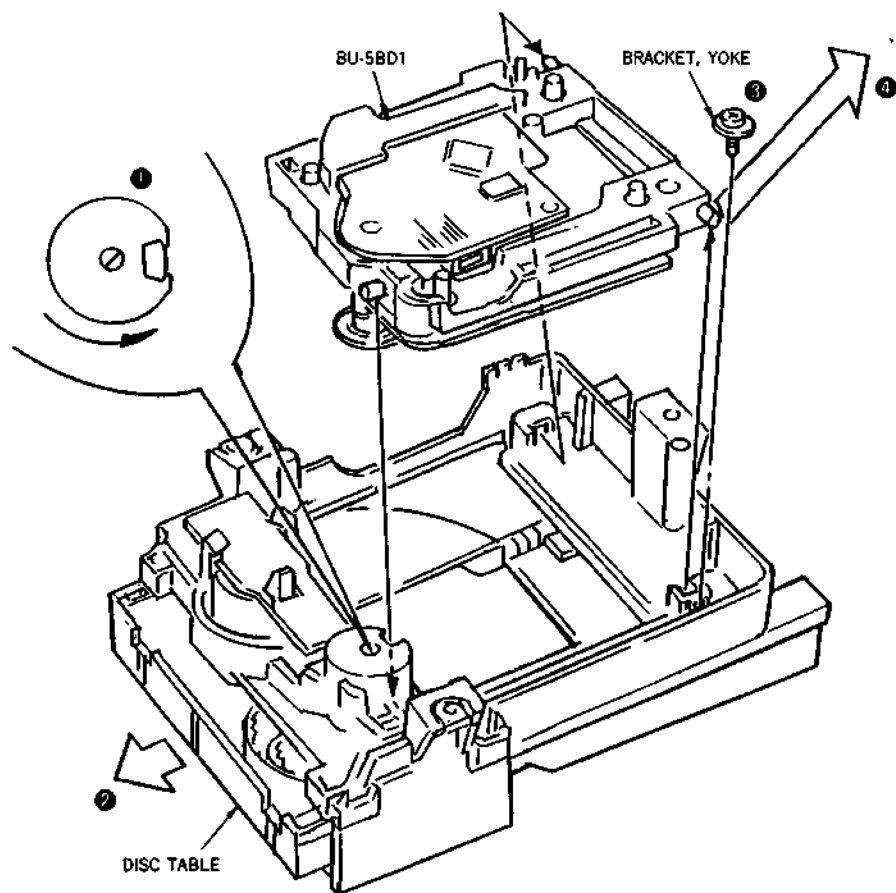

SECTION 4 ADJUSTMENTS

ELECTRICAL ADJUSTMENTS

1. Perform adjustments in the order given.
2. Use YEDS-18 (Part No. 3-702-101-01) disc unless otherwise indicated.
3. Use the oscilloscope with more than 10MΩ impedance.

RF LEVEL check

This adjustment should be made after replacing the Optical Pick-up Block.

Procedure:

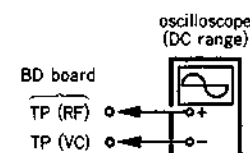

1. Connect oscilloscope to the test points TP (RF) and TP (VC).
2. Turn POWER switch on.
3. Put the disc (YEDS-18) in and press ▷ button.
4. Confirm that an optimum waveform eye pattern. Optimum eye pattern means that shape "◇" can be clearly distinguished at the center of the waveform.

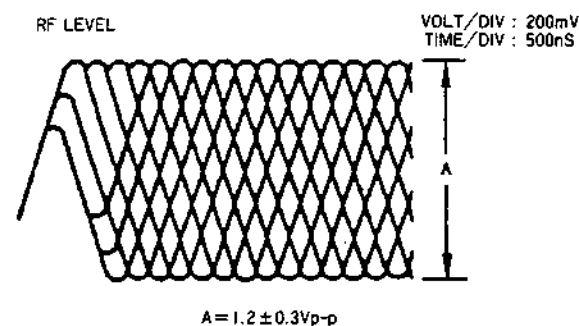

E-F Balance Check

This adjustment should be made after replacing the Optical Pick-up Block.

Procedure:

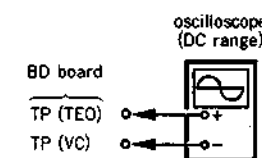

1. Connect the oscilloscope to the test points TP (TEO) and TP (VC).
2. Ground TP (ADJ), TP (TES).
3. Turn POWER switch on.

4. Put the disc (YEDS-18) in and press ▷ button.
5. Confirm that the traverse waveform is symmetrical above and below.
6. After adjustment, remove the TP(ADJ), TP(TES) in ground.

NOTE: Take sweep time as long as possible to obtain best waveform.

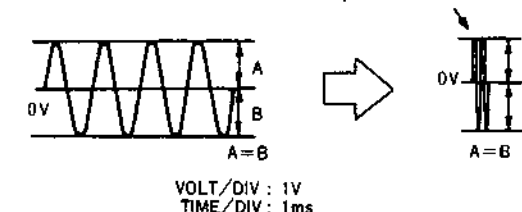

RF PLL Free-run Frequency Check

Procedure:

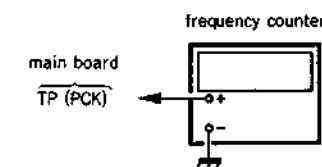

1. Connect the frequency counter to the test points TP (PCK) and TP (GND).
2. Turn POWER switch on.
3. Put the disc (YEDS-18) in and press ▷ button.
4. Confirm that the reading on the frequency counter is locked at 4.3218 MHz.

Focus/Tracking Gain Adjustment

A frequency response analyzer is necessary in order to perform this adjustment exactly.

However, this gain has a margine, so even if it is slightly off, there is no problem. Therefore, this adjustment is not recommended generally to be performed.

Focus/tracking gains determine the pick-up follow-up (vertical and horizontal) relative to mechanical noise and mechanical shock when the 2-axis device operate.

However, as these reciprocate, the adjustment is at the point where both are satisfied.

- When gain is raised, the noise when the 2-axis device operates increases.
- When gain is lowered, it is more susceptible to mechanical shock and skipping occurs more easily.
- When gain adjustment is off, the symptoms below appear.

SECTION 4 ADJUSTMENTS

- Put the disc (YEDS-18) in and press \triangleright button.
- Confirm that the traverse waveform is symmetrical above and below.
- After adjustment, remove the TP(ADJ), TP(TES) in ground.

NOTE: Take sweep time as long as possible to obtain best waveform.

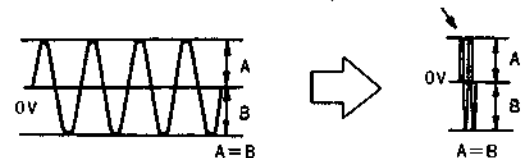

VOLT/DIV : 1V
TIME/DIV : 1ms

RF PLL Free-run Frequency Check

Procedure:

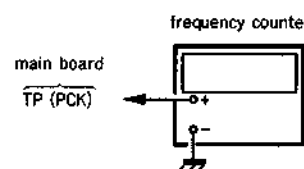

- Connect the frequency counter to the test points TP (PCK) and TP (GND).
- Turn POWER switch on.
- Put the disc (YEDS-18) in and press \triangleright button.
- Confirm that the reading on the frequency counter is locked at 4.3218 MHz.

Focus/Tracking Gain Adjustment

A frequency response analyzer is necessary in order to perform this adjustment exactly.

However, this gain has a margin, so even if it is slightly off, there is no problem. Therefore, this adjustment is not recommended generally to be performed.

Focus/tracking gains determine the pick-up follow-up (vertical and horizontal) relative to mechanical noise and mechanical shock when the 2-axis device operate.

However, as these reciprocate, the adjustment is at the point where both are satisfied.

- When gain is raised, the noise when the 2-axis device operates increases.
- When gain is lowered, it is more susceptible to mechanical shock and skipping occurs more easily.
- When gain adjustment is off, the symptoms below appear.

Symptoms	Gain	Focus	Tracking
• The time until music starts becomes longer for STOP \rightarrow \triangleright PLAY or automatic selection (\lll \ggg buttons) pressed. (Normally takes about 2 seconds.)		low	low or high
• Music does not start and disc continues to rotate for STOP \rightarrow \triangleright PLAY or automatic selection (\lll \ggg buttons) pressed.)		—	low
• Sound is interrupted during PLAY. Or time counter display stops progressing.		—	low
• More noise during 2-axis device operation.		high	high

The following is a simple adjustment method.

Simple Adjustment

Note: Since exact adjustment cannot be performed, remember the positions of the controls before performing the adjustment. If the positions after the simple adjustment are only a little different, return the controls to the original position.

Procedure:

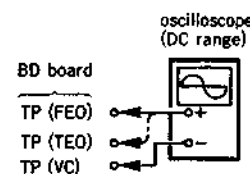

- Keep the set flat.
If the set is not horizontal, this adjustment cannot be performed due to the gravity against the 2 axis device.
- Insert the disc (YEDS-18) and press \triangleright PLAY button.
- Connect the oscilloscope to TP (FEO) and TP (VC).
- Adjustment RV102 so that the waveform is as shown in the picture below. (focus gain adjustment)

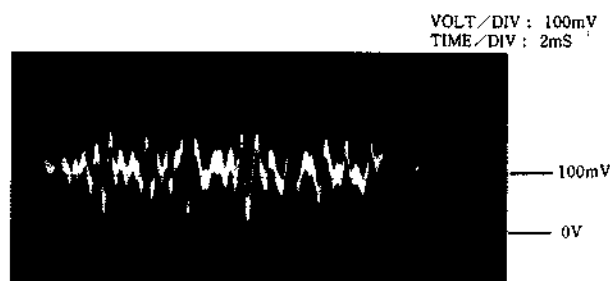

- Incorrect Examples (DC level is quite different from the adjusted waveform) (below)

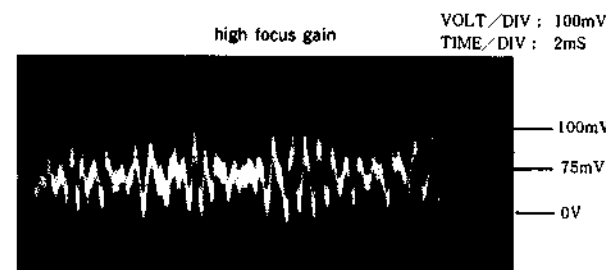
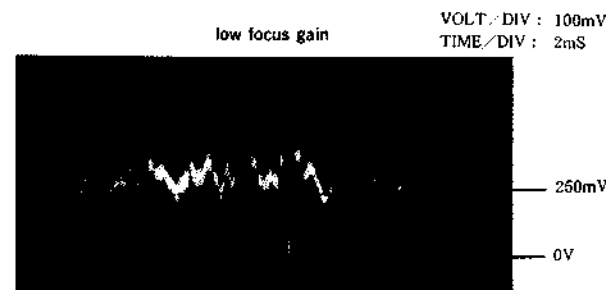

- Connect the oscilloscope to BD BOARD, TP (TEO).
- Adjust RV101 so that the waveform is as shown in the picture below. (tracking gain adjustment)



- Incorrect Examples (fundamental wave appears)

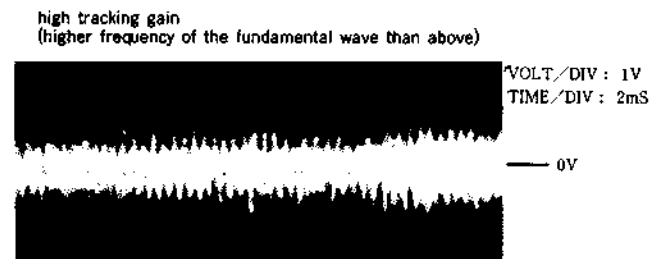
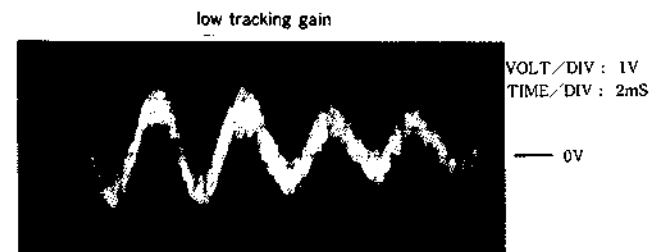

Adjustment Location : MAIN BOARD (Component side)

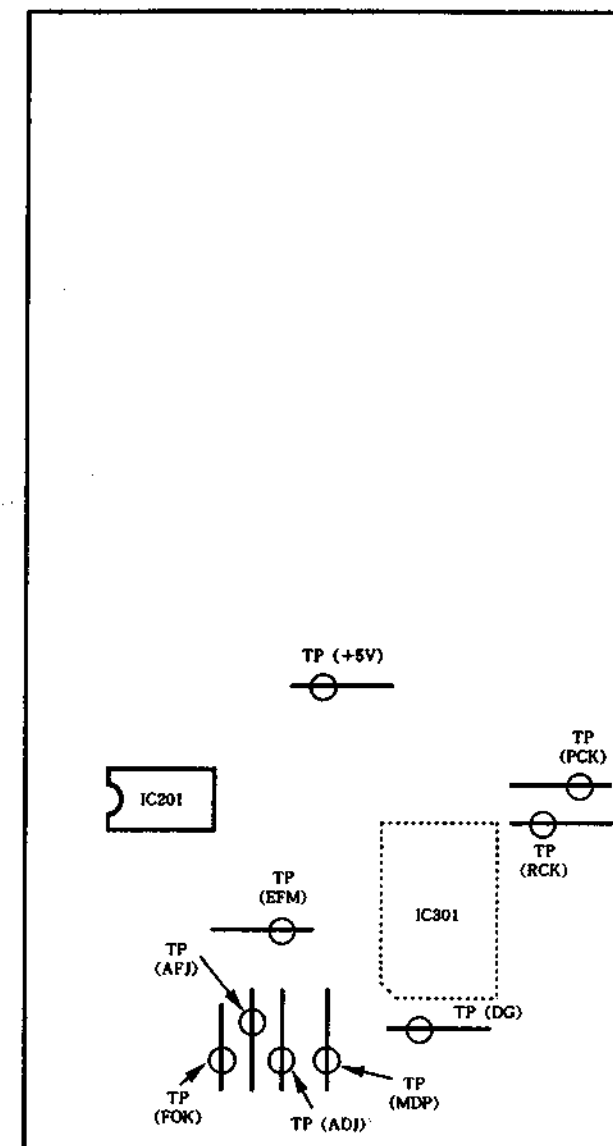

SECTION 5 DIAGRAMS

5-1. WAVEFORMS

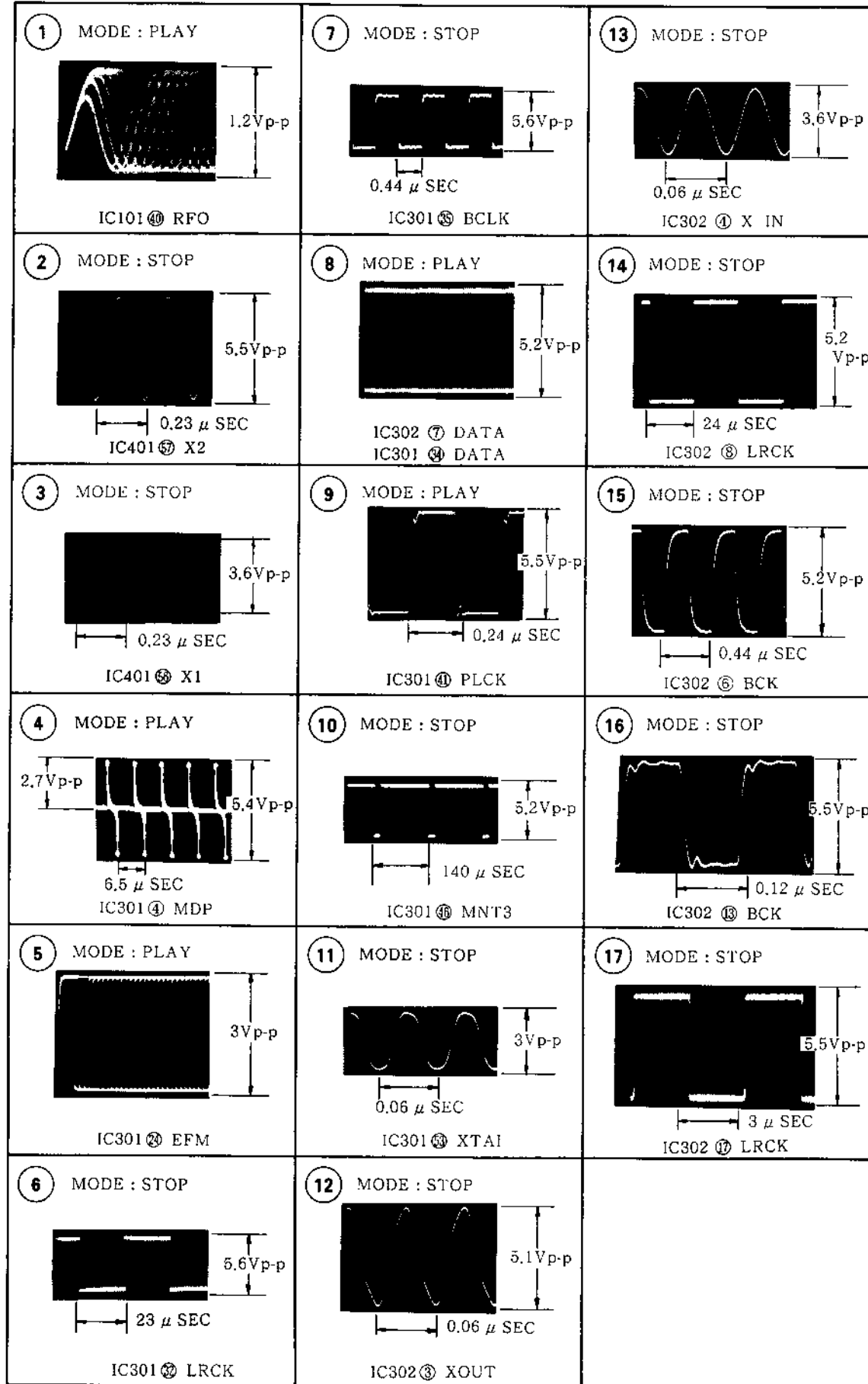

BD BOARD (Component side)

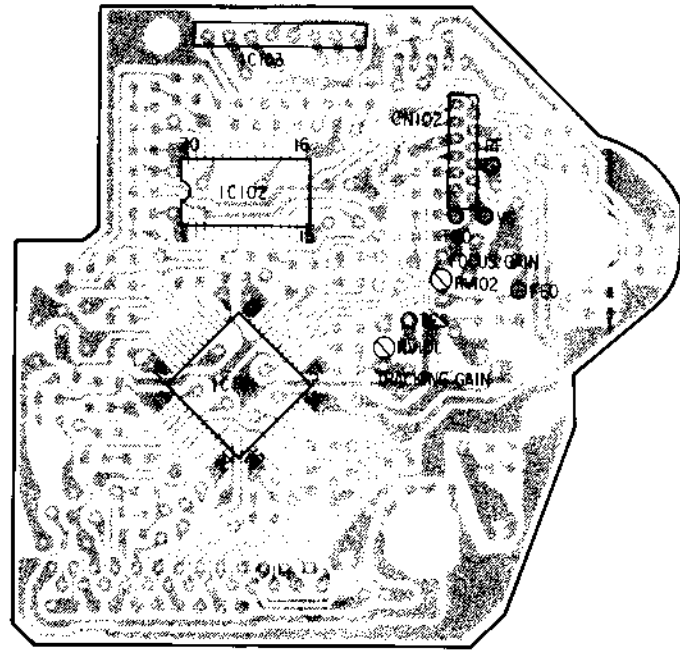

● Semiconductor Lead Layouts

GP1U52XB

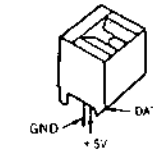

2SB1094-L

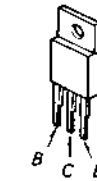

M5293L



2SC2458-YGR



M54641L

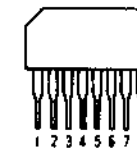

2SD774-34



2SA1175-HFE

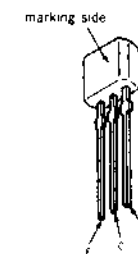

11ES2
1SS202-1
HZS9B2L
RD6.2ES-B2
RD6.3ES-L3
RD8.2ES-B2

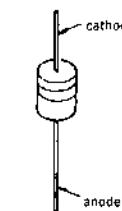

5-2. PRINTED WIRING

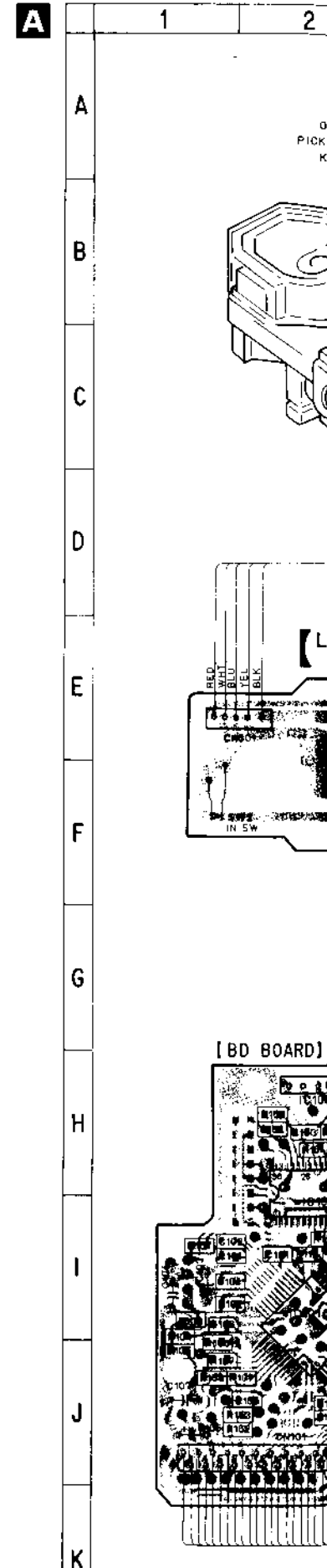

ION 5
RAMS

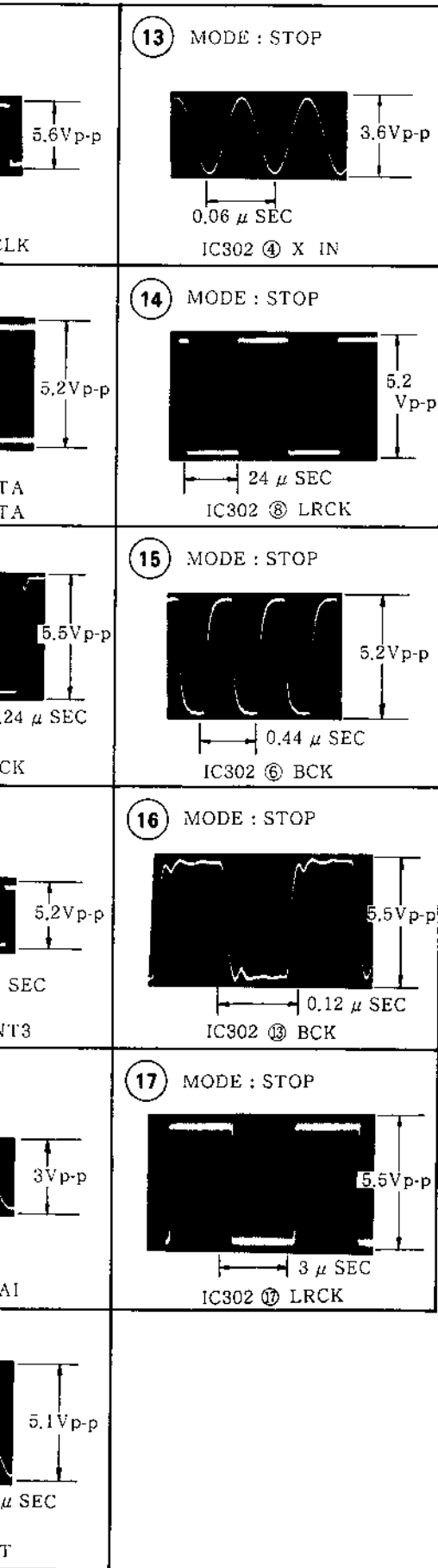

● Semiconductor Lead Layouts

GP1U52XB

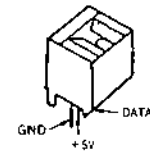

2SB1094-L



M5293L



2SC2458-YGR



M54641L

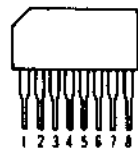

2SD774-34



2SA1175-HFE

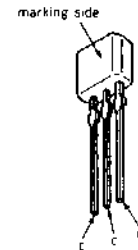

11ES2
1SS202-1
HZS9B2L
RD6.2ES-B2
RD6.3ES-L3
RD8.2ES-B2

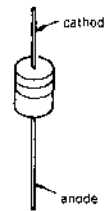

5-2. PRINTED WIRING BOARDS

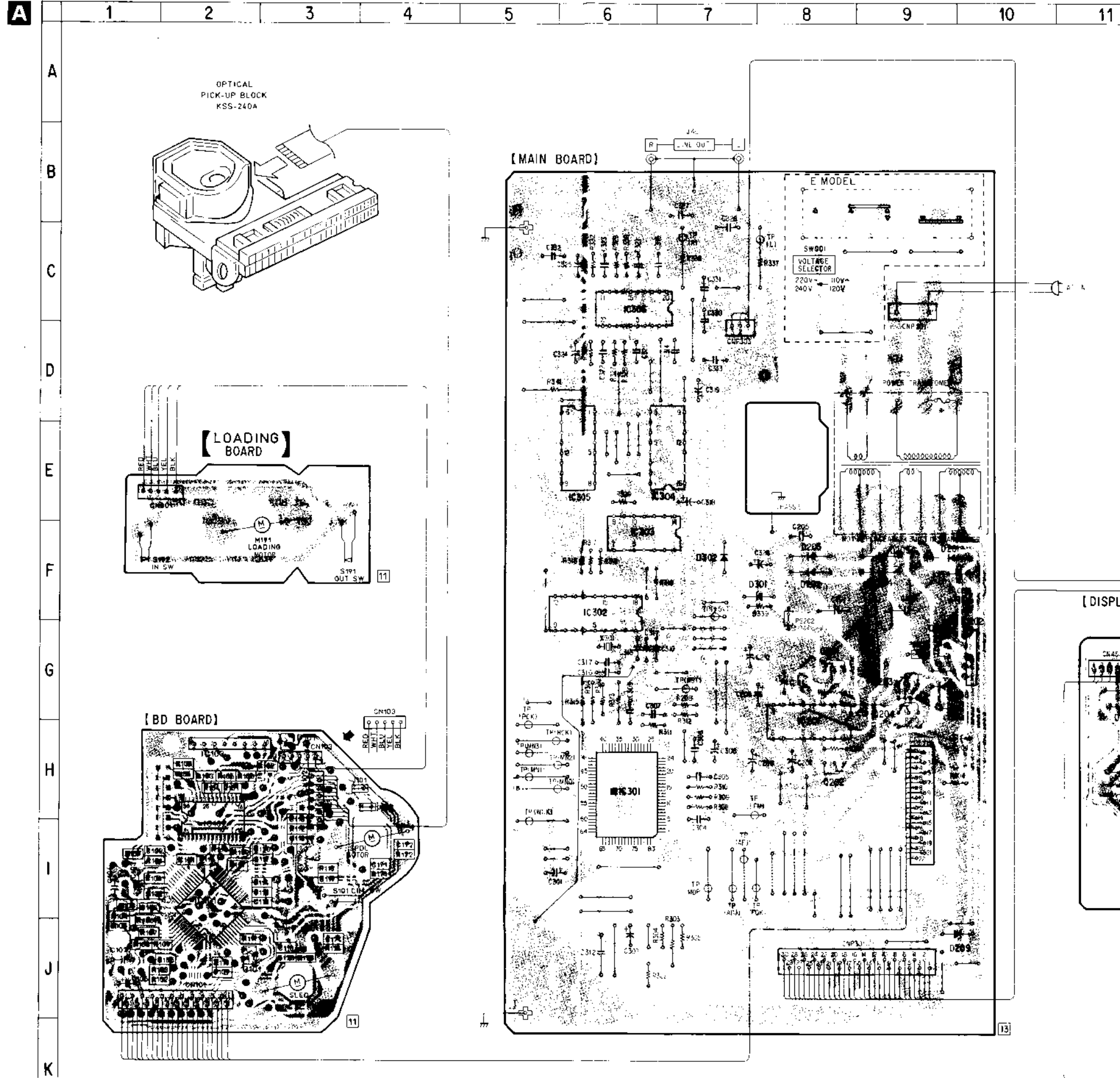

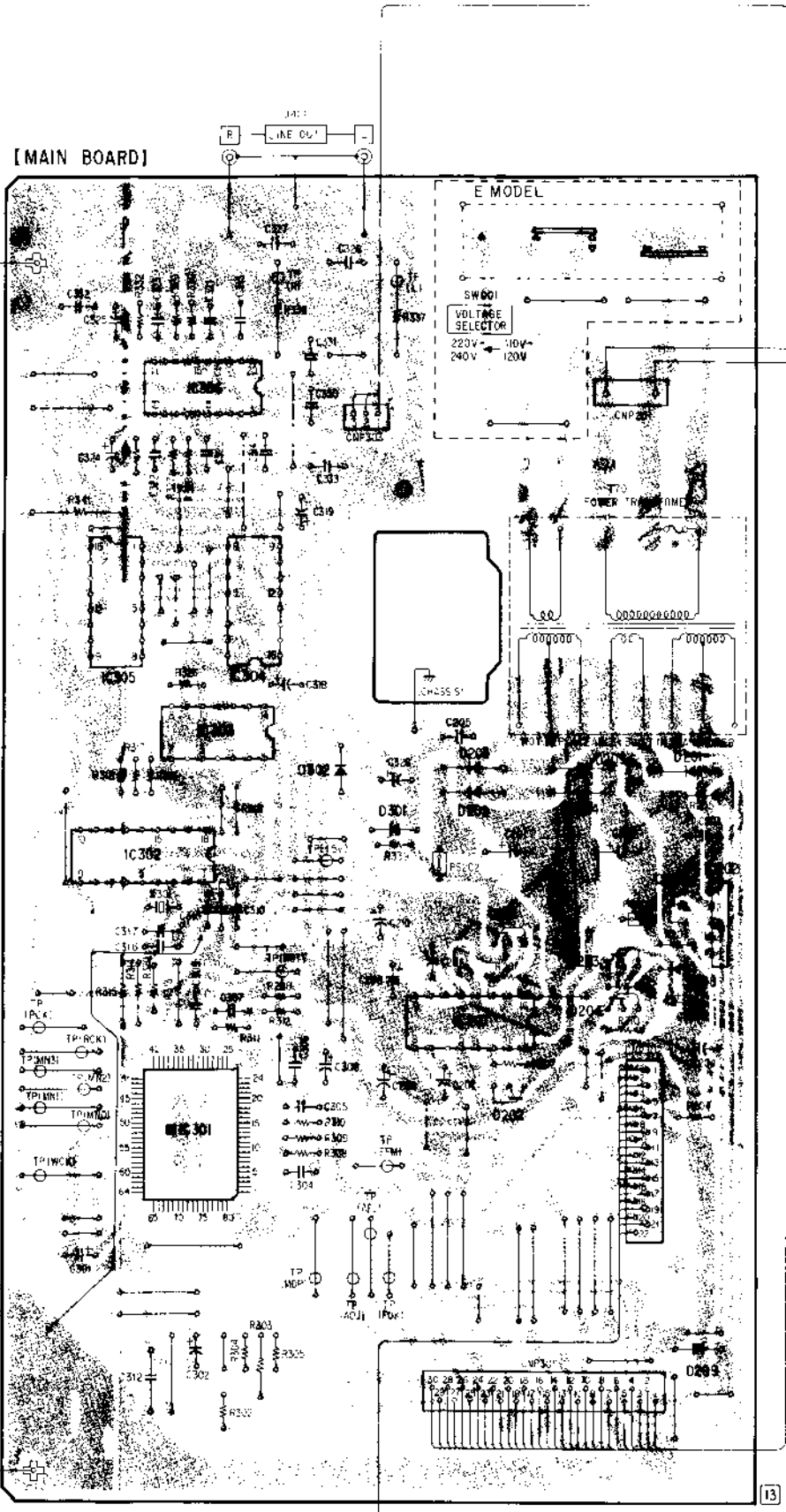

Note:

- : parts extracted from the component side.
- : parts mounted on the conductor side.
- : Through hole.
- : Pattern on the side which is seen.
- : Pattern of the rear side.

● Semiconductor Locations

Ref. No.	Location	Ref. No.	Location
D101	H-3	IC101	I-2
D201	F-9	IC102	H-2
D202	F-8	IC103	H-2
D203	F-8	IC201	G-8
D204	F-9	IC202	G-10
D205	F-9	IC301	H-6
D208	G-8	IC302	F-6
D209	J-9	IC303	F-6
D301	F-8	IC304	E-7
D302	F-7	IC305	E-6
D401	I-14	IC306	C-6
D402	I-15	IC401	H-13
D403	I-15	IC451	J-22
D404	I-15		
D405	I-15	Q101	J-2
D406	I-15	Q201	G-8
D407	I-14	Q202	H-8
D408	I-14	Q203	G-9
D409	I-14	Q204	G-9
D410	G-11	Q206	G-9

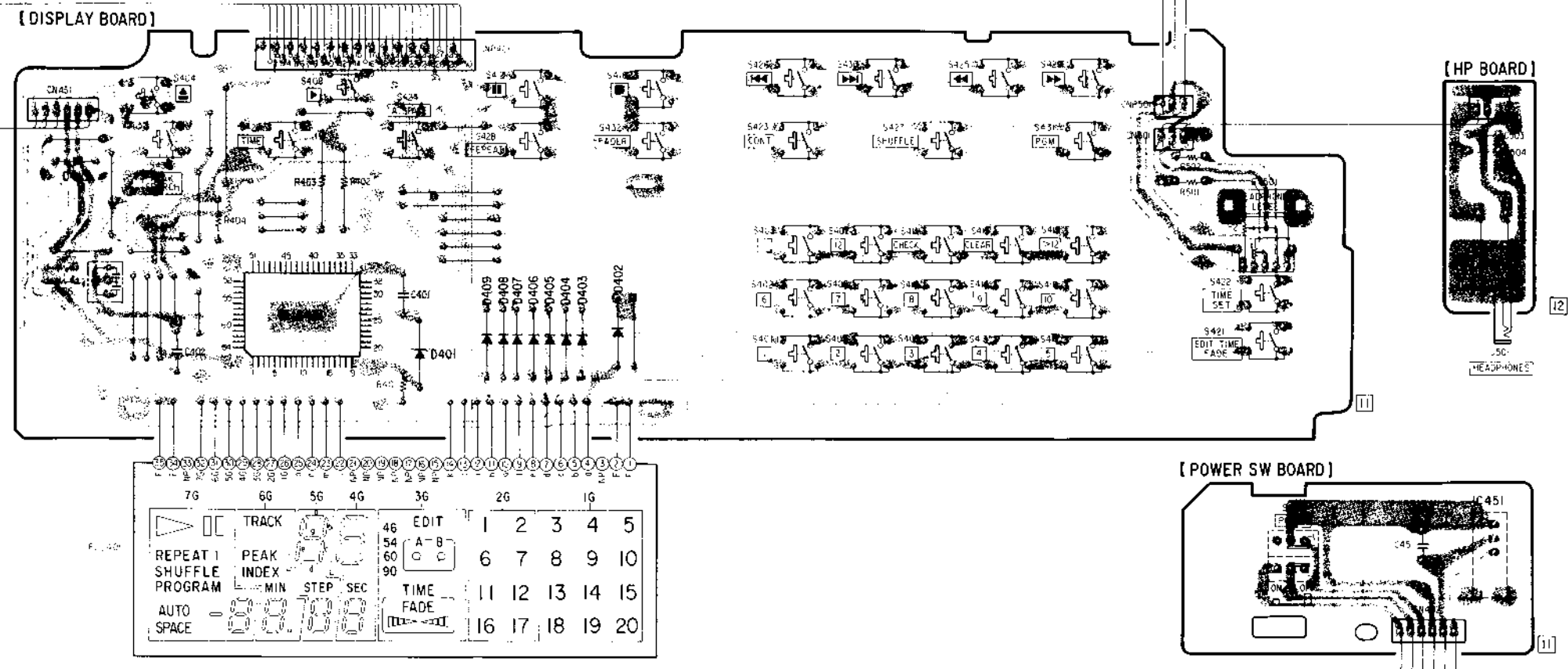

5-3. SCHEMATIC DIAGRAM

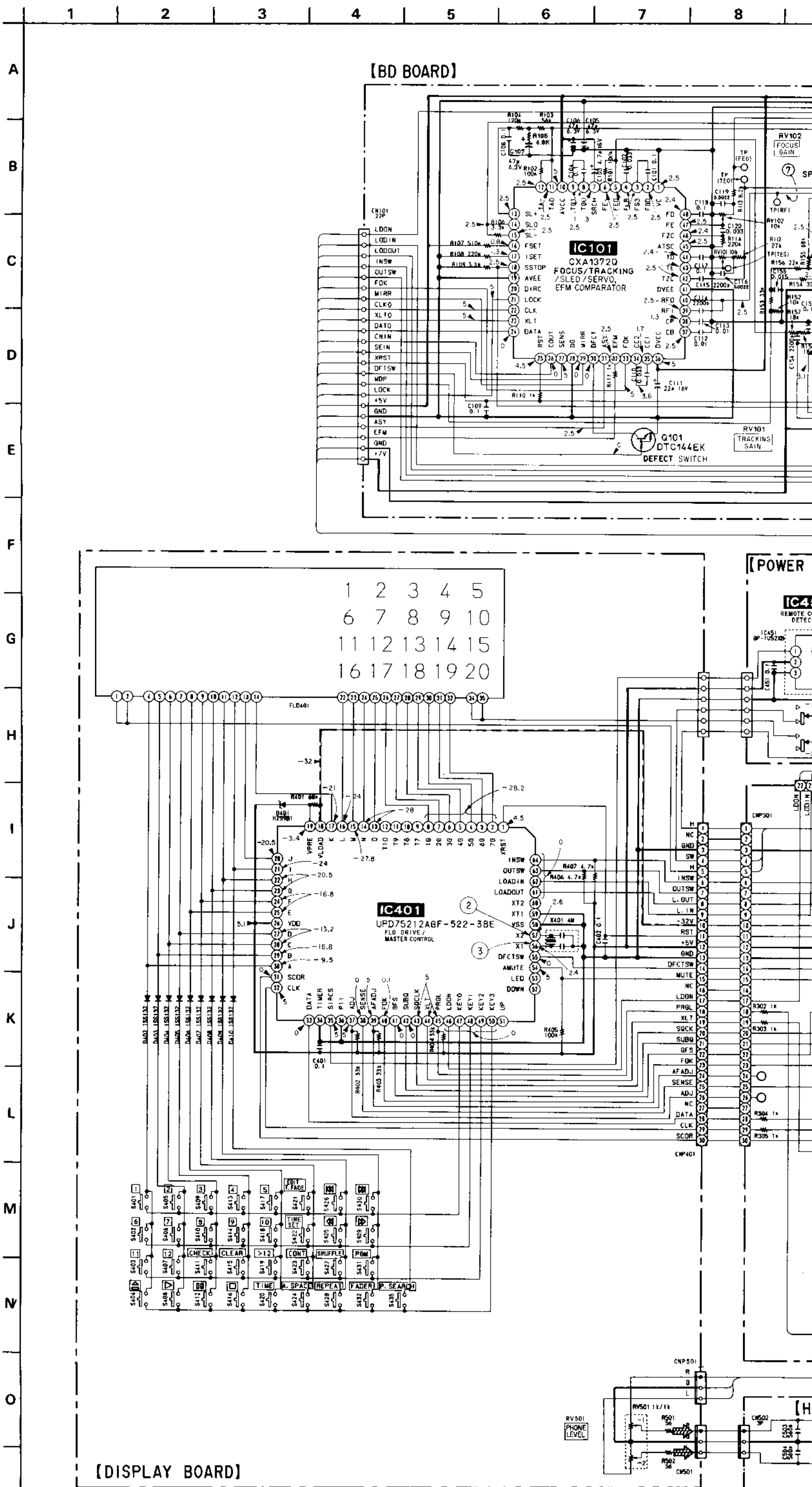

OPTICAL PICK-UP BLOCK (KSS-240A) Δ

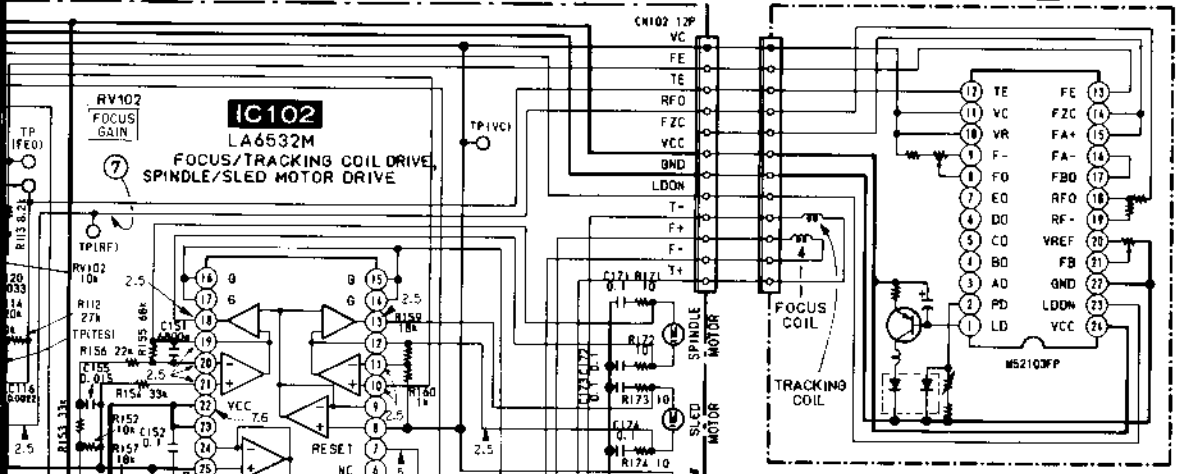

[LOADING BOARD]

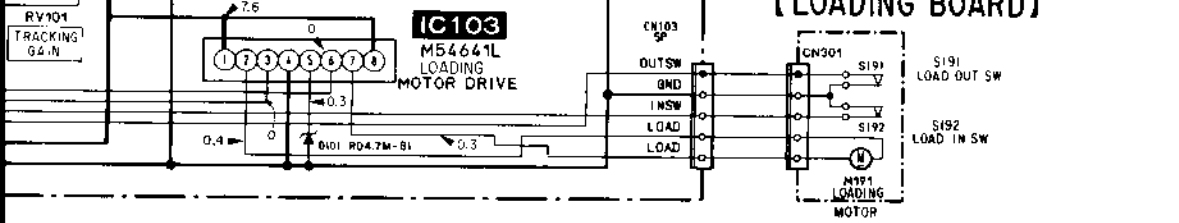

[MAIN BOARD]

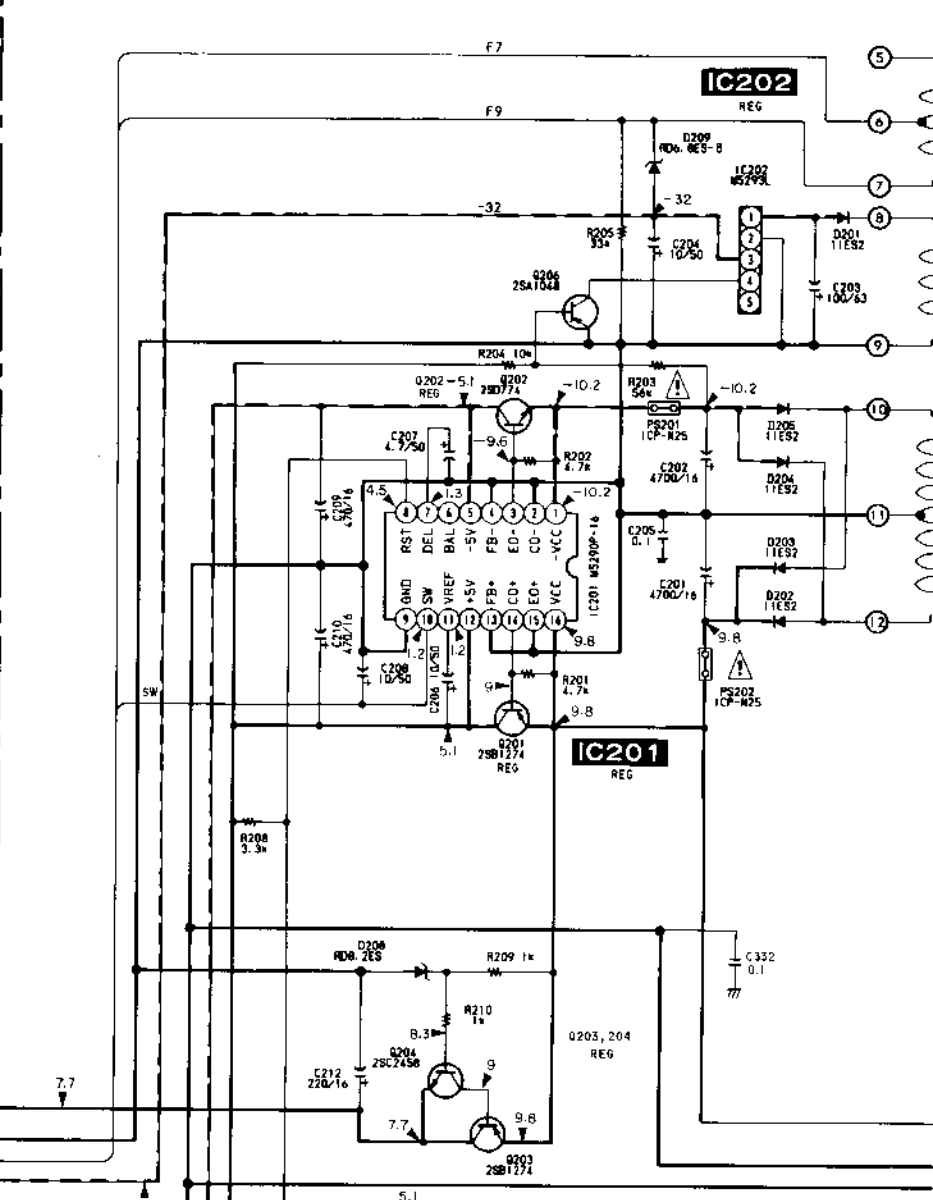

[POWER SW BOARD]

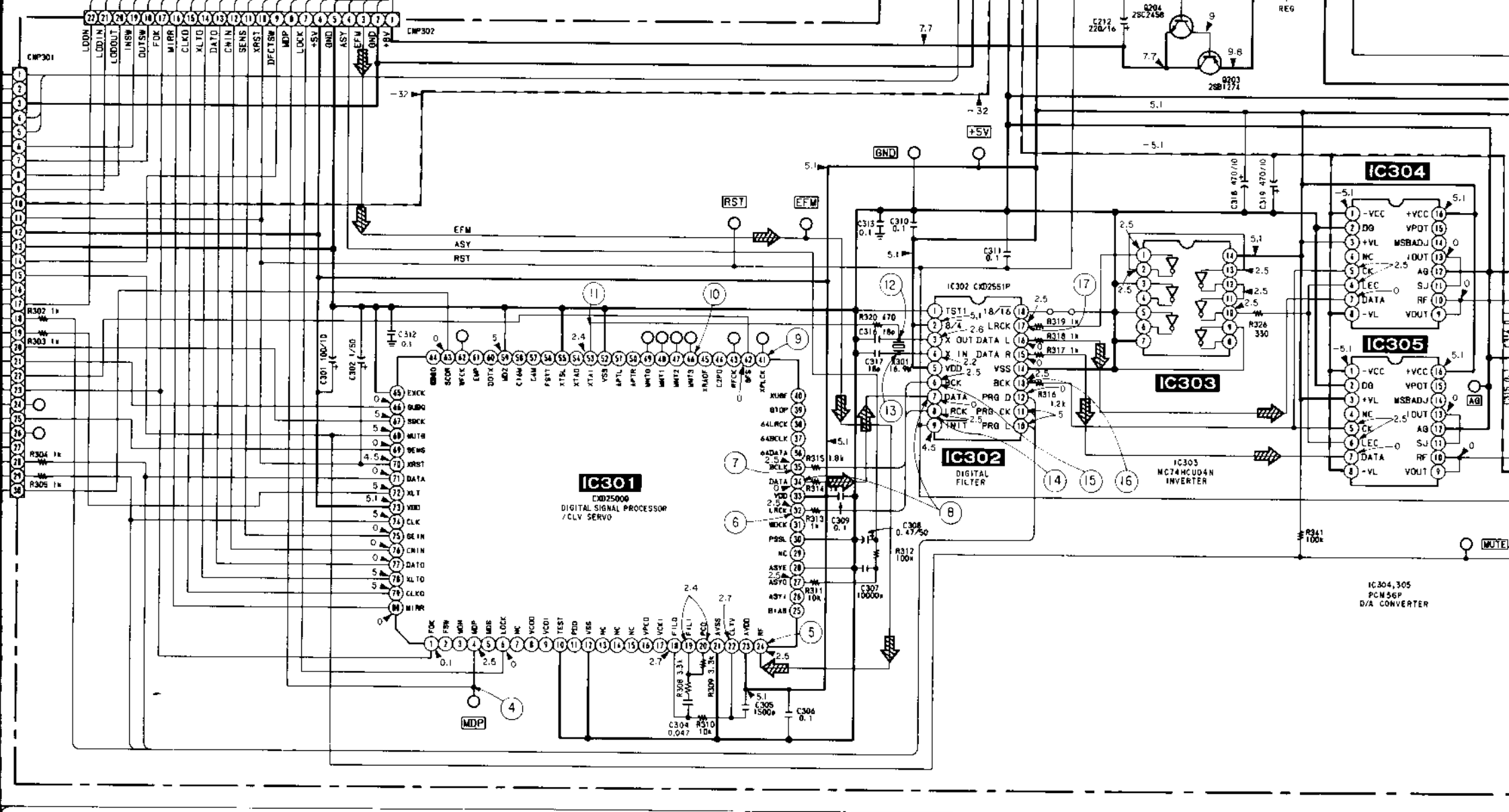
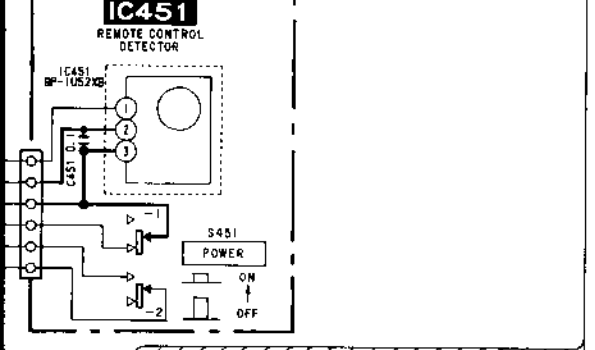

[HP BOARD]



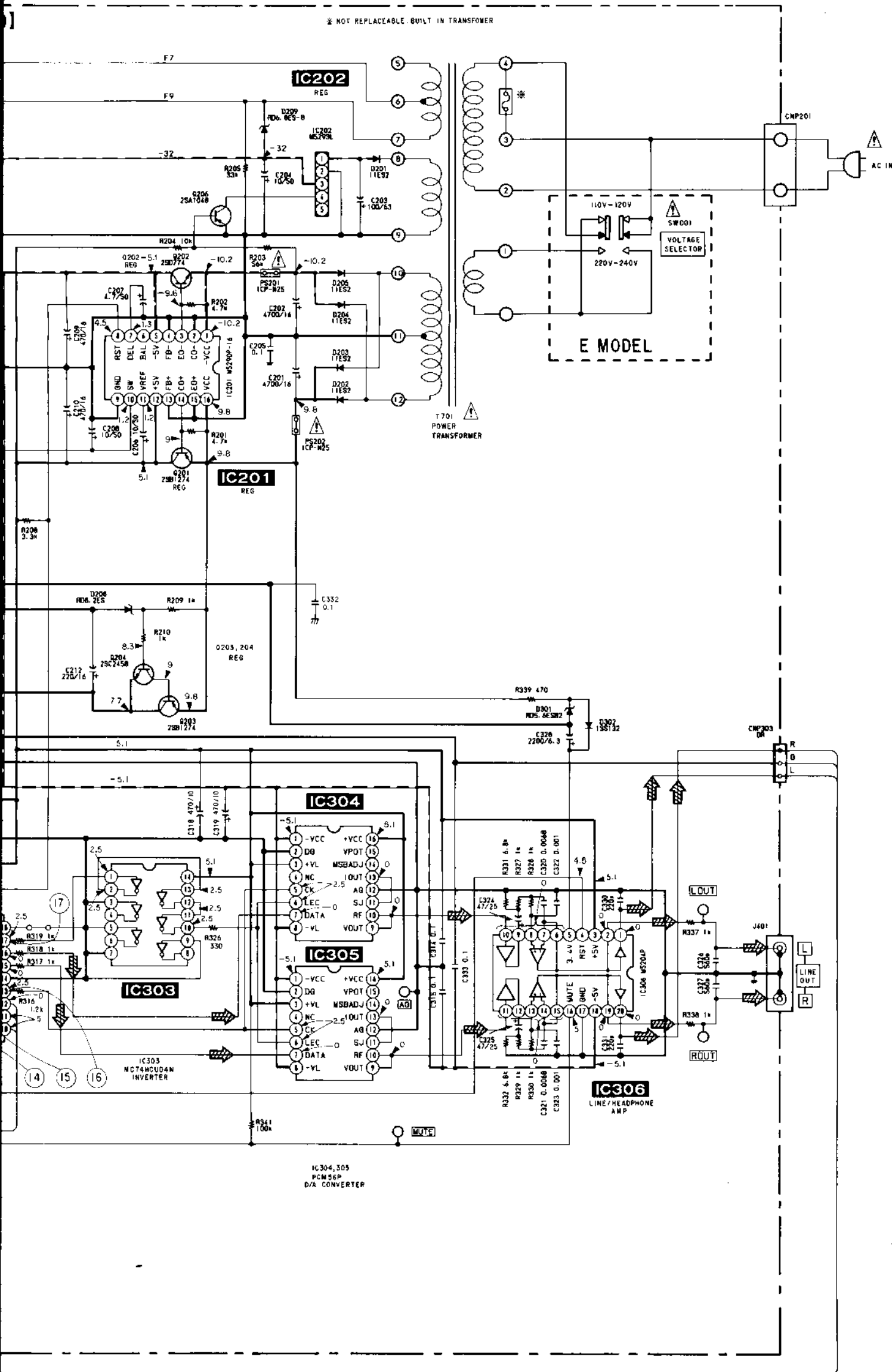

Note:

- All capacitors are in μF unless otherwise noted. ρF : μF 50VV or less are not indicated except for electrolytics and tantalums.
- All resistors are in Ω and $\frac{1}{4}\text{W}$ or less unless otherwise specified.
- % : indicates tolerance.
- Δ : internal component.

Note:

The components identified by mark Δ or dotted line with mark Δ are critical for safety. Replace only with part number specified.

Note:

Les composants identifiés par une marque Δ sont critiques pour la sécurité. Ne les remplacer que par une pièce portant le numéro spécifié.

- — : B+ Line
- - - - : B- Line
- : adjustment for repair.
- Voltage and waveforms are dc with respect to ground under no-signal (detuned) conditions. no mark : STOP
- Voltages are taken with a VOM (Input Impedance $10\text{M}\Omega$). Voltage variations may be noted due to normal production tolerances.
- Waveforms are taken with a oscilloscope. Voltage variations may be noted due to normal production tolerances.
- Circled numbers refer to waveforms.
- Signal path.
- \Rightarrow : CO

5-4. IC BLOCK DIAGRAMS

IC102
LA6532M

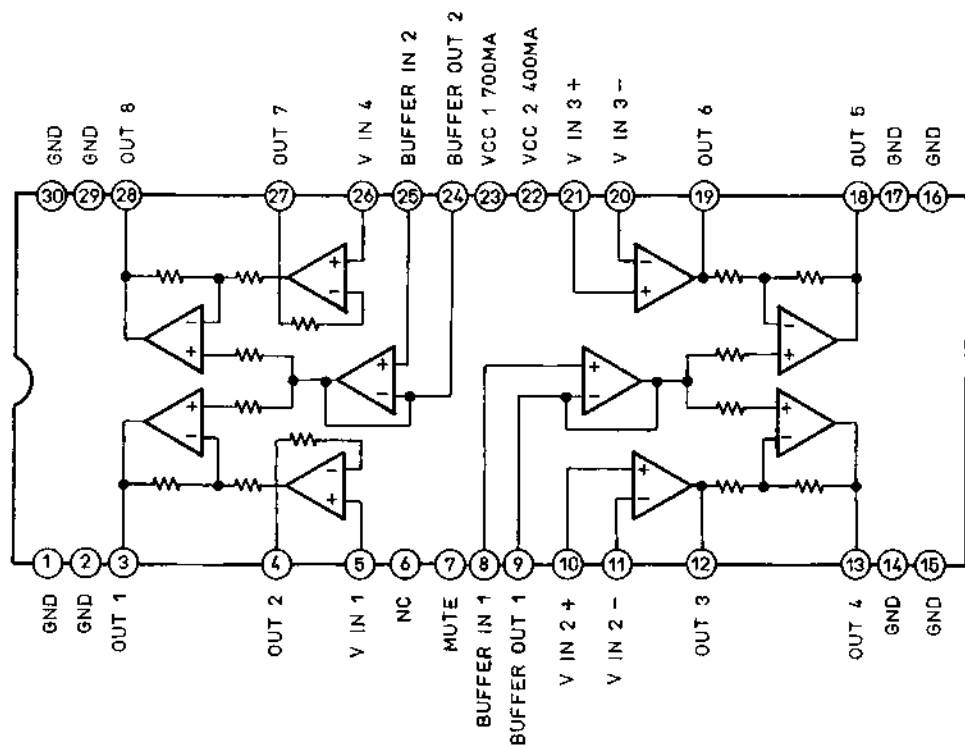

IC103
M54641L

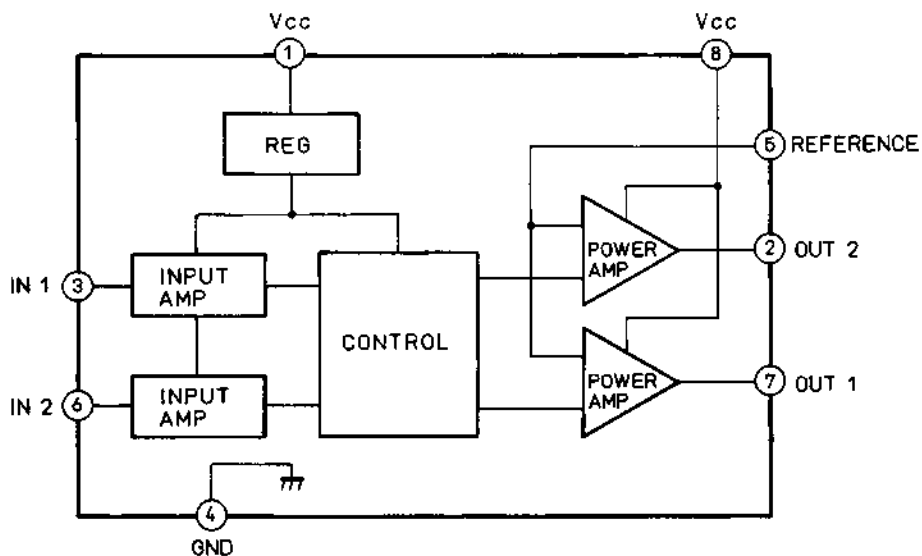

IC201
M5290P-16

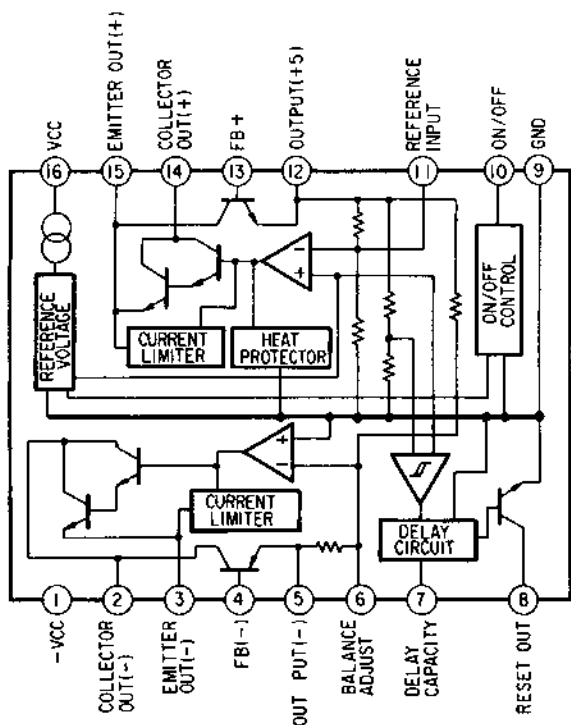

IC301
CXD2500Q

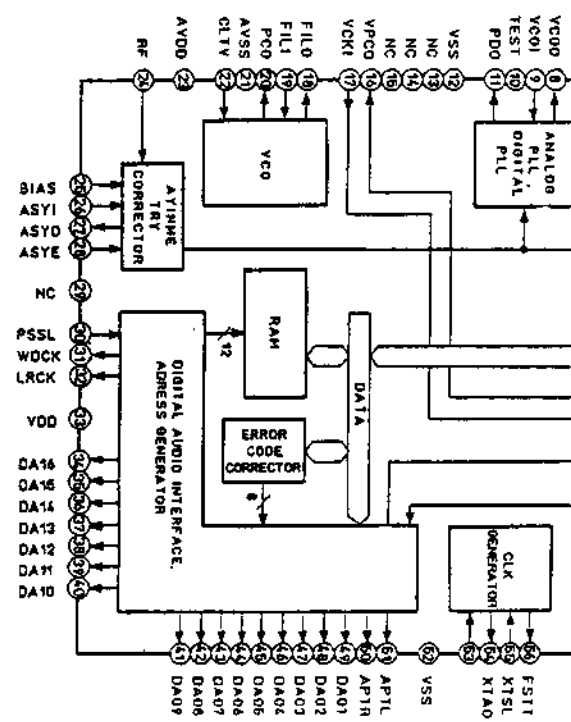

IC302
CXD2551P

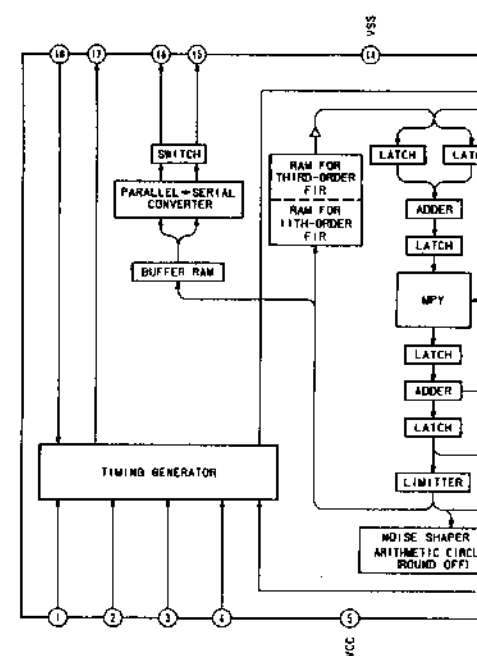

IC304, 305
PCM56

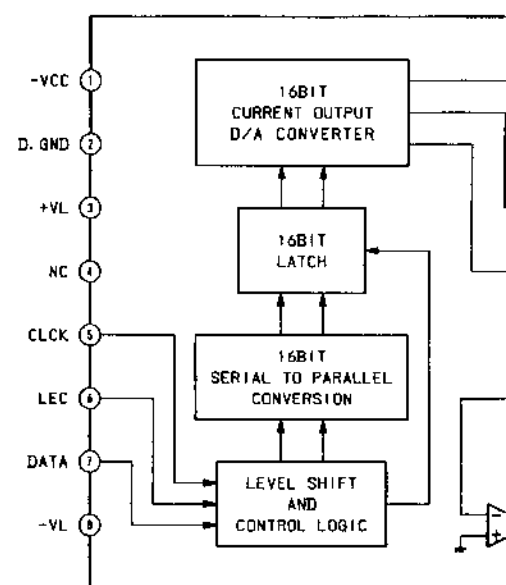

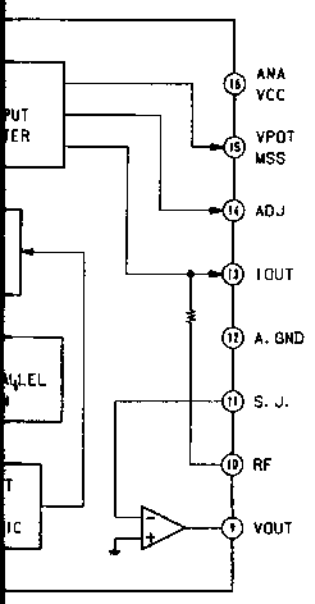
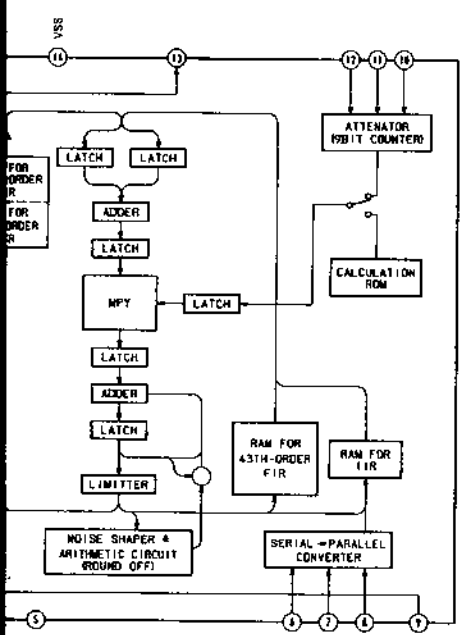
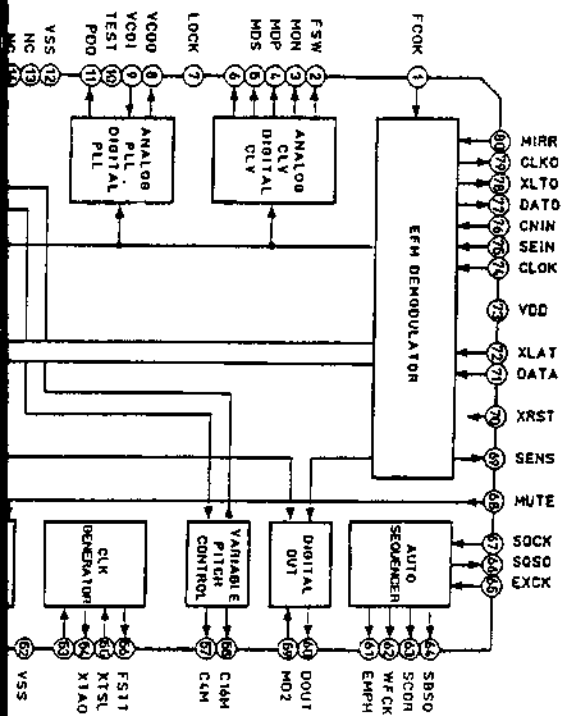

SECTION 6 EXPLODED VIEWS

NOTE:

- The mechanical parts with no reference number in the exploded views are not supplied.
- The construction parts of an assembled part are indicated with a collation number in the remark column.
- Items marked "*" are not stocked since they are seldom required for routine service. Some delay should be anticipated when ordering these items.

- Due to standardization, parts with part number suffix -XX and -X may be different from the parts specified in the components used on the set.
- Color Indication of Appearance Parts
Example:
(RED) ... KNOB, BALANCE (WHITE)
↑ Cabinet's Color ↑ Parts' Color

The components identified by mark Δ or dotted line with mark Δ are critical for safety. Replace only with part number specified.

Les composants identifiés par une marque Δ sont critiques pour la sécurité. Ne les remplacer que par une pièce portant le numéro spécifié.

6-1. CABINET SECTION

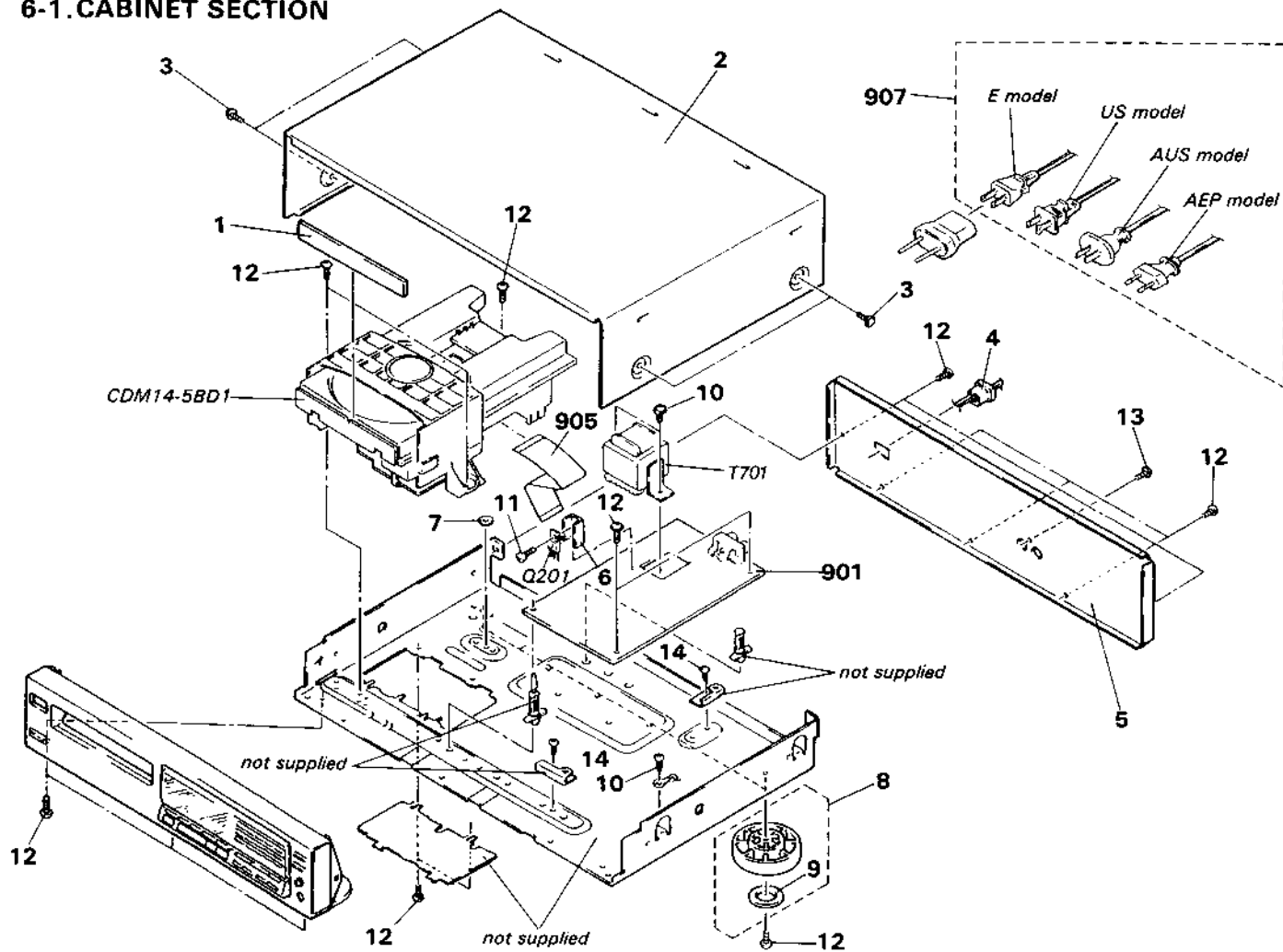

No.	Part No.	Description	Remarks	No.	Part No.	Description	Remarks
1	4-933-208-03	(E,AEP,AUS)...PANEL, LOADING		9	4-923-836-11	CUSHION	
	4-933-208-51	(US).....PANEL, LOADING		10	2-383-566-00	SCREW	
2	4-929-035-31	CASE		11	7-682-547-09	SCREW +B 3X6	
3	3-704-366-31	SCREW (CASE) (M3X6)		12	7-682-548-09	SCREW +BVTT 3X8 (S)	
				13	7-685-646-79	SCREW +BVTP 3X8 TYPE2 N-S	
4	*3-703-244-00	(US,AEP,AUS)...BUSHING (2104), CORD		14	7-682-547-04	SCREW +BVTT 3X6 (S)	
	*3-703-571-11	(E).....BUSHING (S)(4516), CORD		901	*A-4617-315-A	(E).....MOUNTED PCB, MAIN	
	*4-933-201-11	(US)....PANEL, BACK		*A-4617-494-A	(US,AEP,AUS)...MOUNTED PCB, MAIN		
	*4-933-201-31	(AEP)...PANEL, BACK		905	1-575-002-11	WIRE, FLAT TYPE (22 CORE)	
5	*4-933-201-41	(E)....PANEL, BACK		907	Δ .1-575-104-11	(E).....CORD, POWER	
	*4-933-201-91	(AUS)...PANEL, BACK		Δ .1-575-105-11	(US)....CORD, POWER		
	6	4-902-345-01	HEAT SINK	Δ .1-575-453-11	(AEP)...CORD, POWER		
	7	*4-933-220-01	SPACER (MD)	Δ .1-575-677-11	(AUS)...CORD, POWER		
8	X-3304-938-2	(E,AEP,AUS)...FOOT ASSY		908	Δ .1-526-565-00	(E)...AC PLUG ADAPTOR	
	X-4885-950-1	(US).....FOOT ASSY		9	Q201 8-729-111-67	TRANSISTOR 2SB1094-L	
				T701	Δ .1-449-921-11	(US).....TRANSFORMER, POWER	
				T701	Δ .1-449-922-11	(AEP,AUS)...TRANSFORMER, POWER	
				T701	Δ .1-449-923-11	(E).....TRANSFORMER, POWER	

SECTION 6 VIEWS

ation, parts with part
K and -X may be dif-
parts specified in the
on the set.

of Appearance Parts

, BALANCE (WHITE)

↑
Parts' Color

The components identified by
mark Δ or dotted line with mark
 Δ are critical for safety.
Replace only with part
specified.

Les composants identifiés par une
marque Δ sont critiques pour la
sécurité.
Ne les remplacer que par une
pièce portant le numéro spécifié.

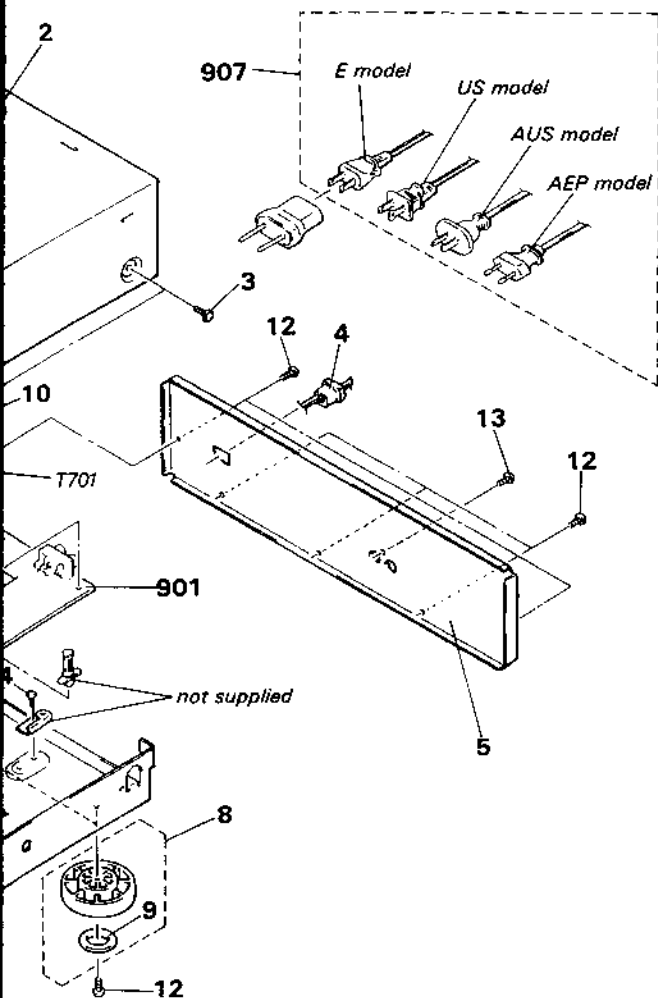

6-2. FRONT PANEL SECTION

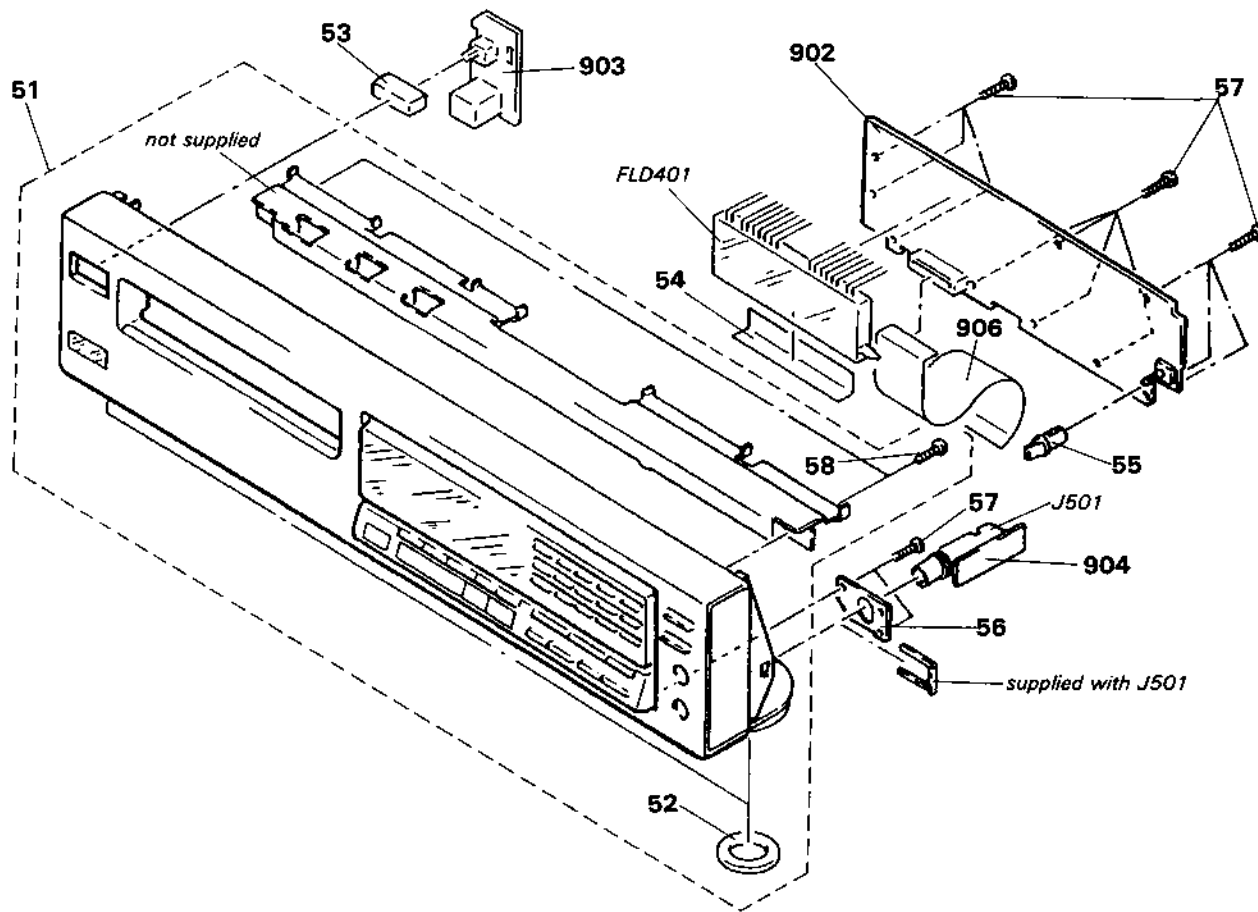

No.	Part No.	Description	Remarks	No.	Part No.	Description	Remarks	No.	Part No.	Description	Remarks
9	4-923-836-11	CUSHION		51	X-4604-397-1	(AEP).....PANEL ASSY, FRONT	52,58	57	4-928-635-01	SCREW, +BY (2.6X8) TAPPING	
10	2-383-566-00	SCREW			X-4604-404-1	(E,AUS)...PANEL ASSY, FRONT	52,58	58	7-685-134-19	SCREW +BTP 2.6X8 TYPE2 N-S	
11	7-682-547-09	SCREW +B 3X6			X-4933-214-1	(US).....PANEL ASSY, FRONT	52,58	902	*1-632-243-11	PC BOARD, DISPLAY	
12	7-682-548-09	SCREW +BYTT 3X8 (S)		52	4-923-836-11	CUSHION		903	*1-632-245-11	PC BOARD, POWER SW	
13	7-685-646-79	SCREW +BYTP 3X8 TYPE2 N-S		53	4-922-921-01	BUTTON (POWER)		904	*1-632-244-11	PC BOARD, HP	
14	7-682-547-04	SCREW +BYTT 3X6 (S)		54	*4-927-353-01	SHEET (FL)		906	1-575-120-11	WIRE, FLAT TYPE (30 CORE)	
01	*A-4617-315-A	(E).....MOUNTED PCB, MAIN		55	4-933-116-11	KNOB (C, TYPE), LOV		FLD401	1-519-556-11	INDICATOR TUBE, FLUORESCENT	
	*A-4617-494-A	(US,AEP,AUS)...MOUNTED PCB, MAIN		56	*4-933-204-01	BRACKET (H.P)		J501	1-568-519-21	JACK, LARGE TYPE	
05	1-575-002-11	WIRE, FLAT TYPE (22 CORE)									
07	Δ 1-575-104-11	(E)....CORD, POWER									
	Δ 1-575-105-11	(US)....CORD, POWER									
	Δ 1-575-453-11	(AEP)...CORD, POWER									
	Δ 1-575-677-11	(AUS)...CORD, POWER									
08	Δ 1-526-565-00	(E)...AC PLUG ADAPTOR									
201	8-729-111-67	TRANSISTOR 2SB1094-L									
701	Δ 1-449-921-11	(US).....TRANSFORMER, POWER									
701	Δ 1-449-922-11	(AEP,AUS)...TRANSFORMER, POWER									
701	Δ 1-449-923-11	(E).....TRANSFORMER, POWER									

6-3.MD SECTION-1 (CDM14-5BD1)

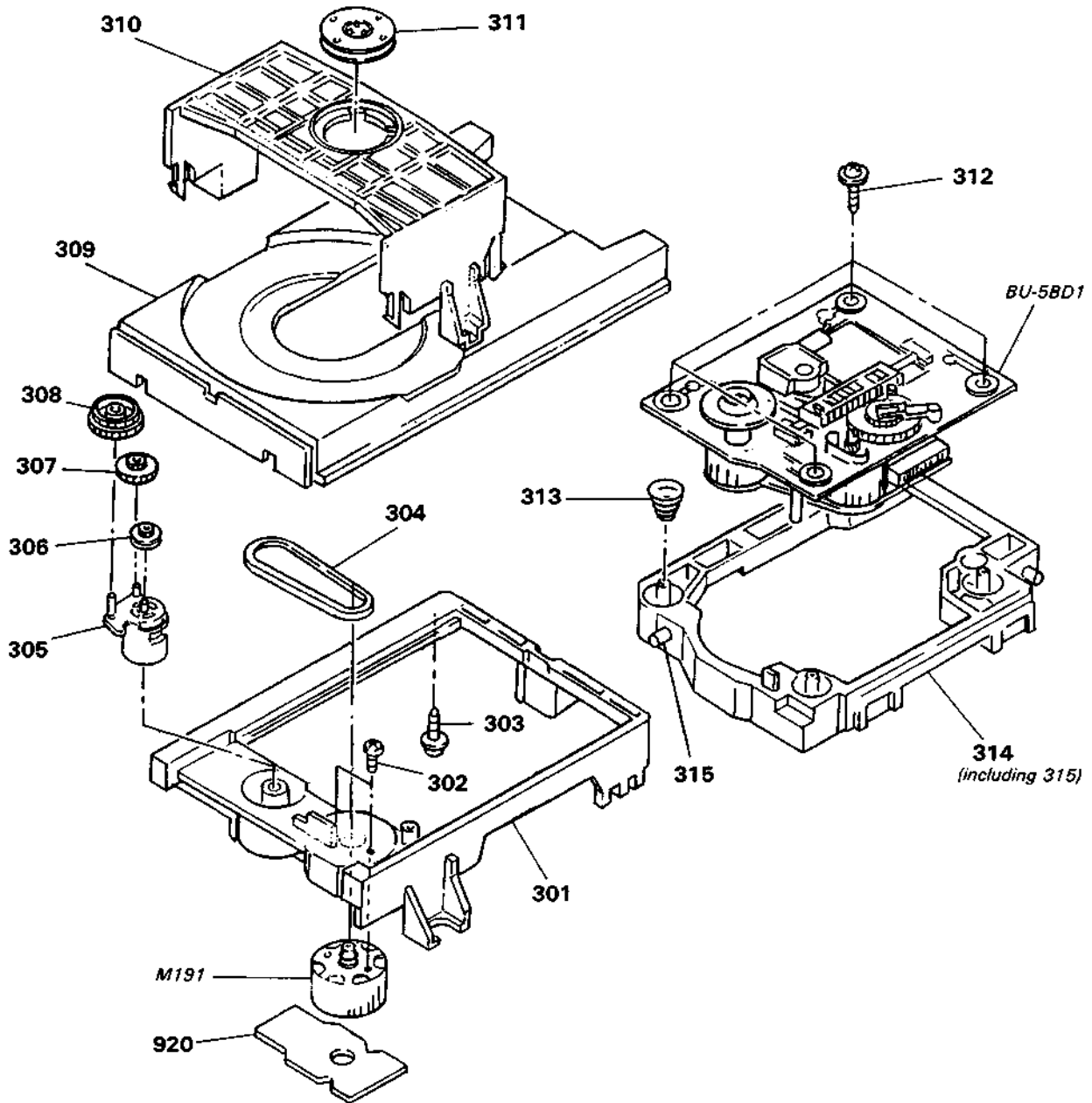

No.	Part No.	Description	Remarks	No.	Part No.	Description	Remarks
301	4-933-111-01	CHASSIS (MD)		310	4-933-110-01	HOLDER (MG)	
302	7-621-775-10	SCREW +B 2.6X4		311	A-4675-347-A	MG ASSY	
303	*4-917-583-21	BRACKET, YOKE		312	4-933-134-01	SCREW (+PTPWH M2.6X6)	
304	4-927-649-01	BELT		313	4-917-541-01	SPRING (B)	
305	4-933-109-01	CAM		314	4-933-129-01	HOLDER (BU)	
306	4-927-651-01	PULLEY (S)		315	4-933-108-01	SHAFT (CAM)	
307	4-927-628-01	GEAR (C)		M191	A-4604-363-A	MOTOR (L) ASSY	
308	4-933-107-01	GEAR (PL)		920	*1-632-202-11	PC BOARD, LOADING	
309	4-933-112-01	TABLE, DISK					

6-4.MD SECTION-2 (BU-5BD1)

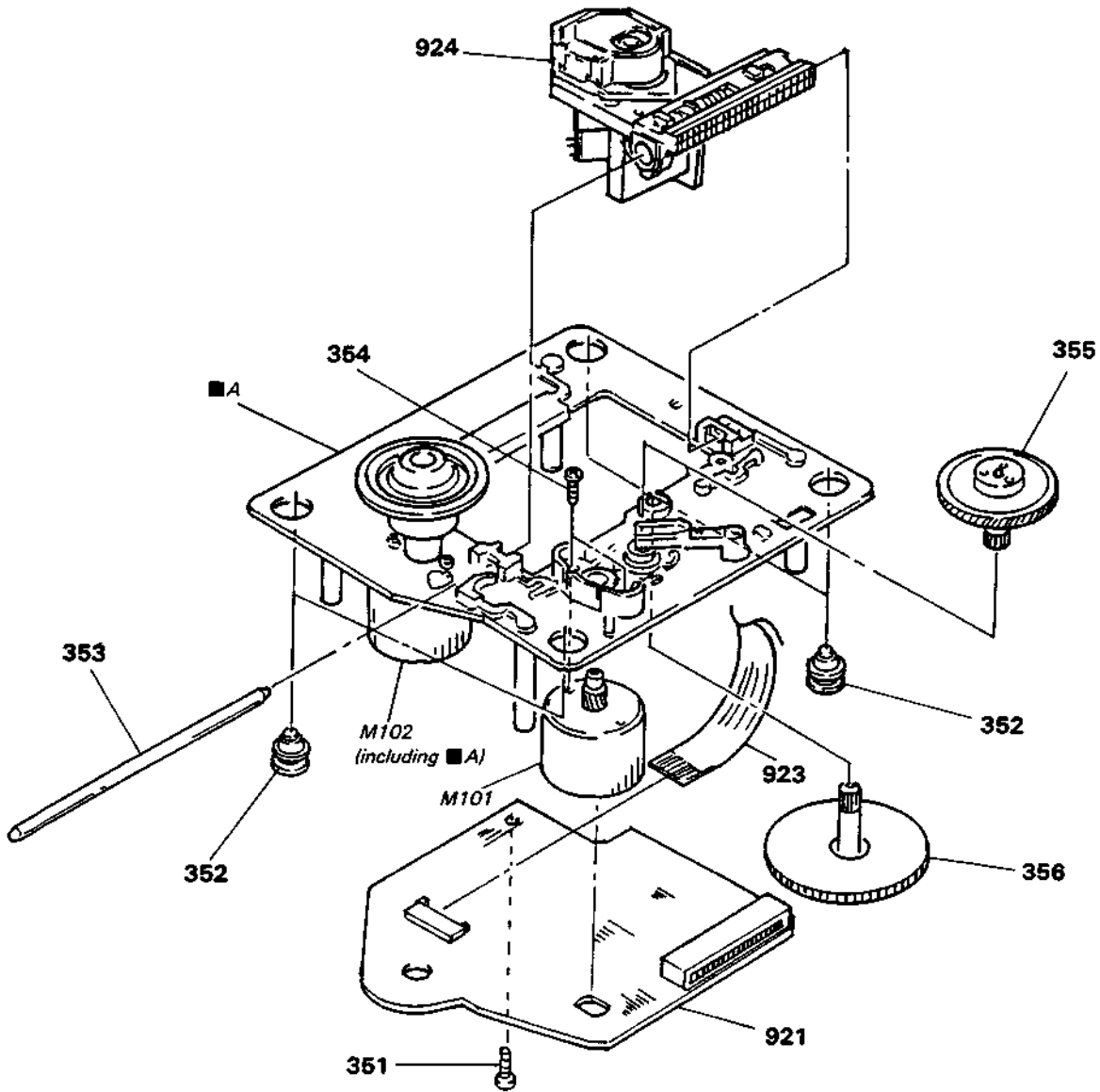

<p>Note: The components identified by mark \triangle or dotted line with mark \triangle are critical for safety. Replace only with part number specified.</p>	<p>Note: Les composants identifiés par une marque \triangle sont critiques pour la sécurité. Ne les remplacer que par une pièce portant le numéro spécifié.</p>
--	---

No.	Part No.	Description	Remarks	No.	Part No.	Description	Remarks
351	7-685-134-19	SCREW +BTP 2.6X8 TYPE2 N-S		921	*A-4617-161-A	MOUNTED PCB, BD	
352	4-933-126-01	INSULATOR (A)		923	1-575-001-11	WIRE, FLAT TYPE (12 CORE)	
353	4-917-565-01	SHAFT, SLED		924	\triangle 8-848-144-11	DEVICE, OPTICAL KSS-240A	
354	7-621-255-15	SCREW +P 2X3		M101	X-4917-504-1	MOTOR ASSY (SLED)	
355	4-917-567-01	GEAR (M)		M102	X-4917-523-3	MOTOR ASSY (SPINDLE)	
356	4-917-564-01	GEAR (P), FLATNESS					

SECTION 7 ELECTRICAL PARTS LIST

NOTE:

- Due to standardization, replacements in the parts list may be different from the parts specified in the diagrams or the components used on the set.
- Items marked "*" are not stocked since they are seldom required for routine service. Some delay should be anticipated when ordering these items.
- If there are two or more same circuits in a set such as a stereophonic machine, only typical circuit parts may be indicated and capacitors and resistors in other same circuits may be omitted.

CAPACITORS:

MF: μ F, PF: μ PF.

RESISTORS

- All resistors are in ohms.
- F: nonflammable

COILS

- MMH: mH, UH: μ H

SEMICONDUCTORS

In each case, U: μ , for example:
 UA...: μ A..., UPA...: μ PA...,
 UPC...: μ PC, UPD...: μ PD...

The components identified by mark Δ or dotted line with mark Δ are critical for safety. Replace only with part number specified.

Les composants identifiés par une marque Δ sont critiques pour la sécurité. Ne les remplacer que par une pièce portant le numéro spécifié.

Ref.No.	Part No.	Description	Ref.No.	Part No.	Description
901	*A-4617-315-A	(E).....MOUNTED PCB, MAIN	C173	1-163-038-00	CERAMIC CHIP 0.1MF 25V
	*A-4617-494-A	(US,AEP,AUS)...MOUNTED PCB, MAIN	C174	1-163-038-00	CERAMIC CHIP 0.1MF 25V
902	*1-632-243-11	PC BOARD, DISPLAY	C201	1-126-842-11	ELECT 4700MF 20% 16V
903	*1-632-245-11	PC BOARD, POWER SW	C202	1-126-842-11	ELECT 4700MF 20% 16V
904	*1-632-244-11	PC BOARD, HP	C203	1-126-880-11	ELECT 100MF 20% 63V
905	1-575-002-11	WIRE, FLAT TYPE (22 CORE)	C204	1-126-059-11	ELECT 10MF 20% 50V
906	1-575-120-11	WIRE, FLAT TYPE (30 CORE)	C205	1-162-851-11	CERAMIC 0.1MF 20% 16V
907	Δ .1-575-104-11	(E).....CORD, POWER	C206	1-126-059-11	ELECT 10MF 20% 50V
	Δ .1-575-105-11	(US)....CORD, POWER	C207	1-124-045-00	ELECT 4.7MF 20% 50V
	Δ .1-575-453-11	(AEP)...CORD, POWER	C208	1-126-059-11	ELECT 10MF 20% 50V
	Δ .1-575-677-11	(AUS)...CORD, POWER	C209	1-126-012-11	ELECT 470MF 20% 16V
908	.1-526-565-00	(E)...AC PLUG ADAPTOR	C210	1-126-012-11	ELECT 470MF 20% 16V
920	*1-632-202-11	PC BOARD, LOADING	C212	1-126-024-11	ELECT 220MF 20% 16V
921	*A-4617-161-A	MOUNTED PCB, BD	C301	1-124-994-11	ELECT 100MF 20% 10V
923	1-575-001-11	WIRE, FLAT TYPE (12 CORE)	C302	1-126-301-11	ELECT 1MF 20% 50V
924	Δ .8-848-144-11	DEVICE, OPTICAL KSS-240A	C304	1-136-161-00	FILM 0.047MF 5% 50V
C101	1-163-038-00	CERAMIC CHIP 0.1MF 25V	C305	1-161-374-11	CERAMIC 0.0015MF 30% 16V
C102	1-163-989-11	CERAMIC CHIP 0.033MF 10% 25V	C306	1-164-159-11	CERAMIC 0.1MF 50V
C103	1-126-094-11	ELECT 4.7MF 20% 16V	C307	1-162-306-11	CERAMIC 0.01MF 20% 16V
C104	1-163-038-00	CERAMIC CHIP 0.1MF 25V	C308	1-126-300-11	ELECT 0.47MF 20% 50V
C105	1-126-154-11	ELECT 47MF 20% 6.3V	C309	1-164-159-11	CERAMIC 0.1MF 50V
C106	1-126-154-11	ELECT 47MF 20% 6.3V	C310	1-164-159-11	CERAMIC 0.1MF 50V
C107	1-126-154-11	ELECT 47MF 20% 6.3V	C311	1-164-159-11	CERAMIC 0.1MF 50V
C108	1-163-038-00	CERAMIC CHIP 0.1MF 25V	C312	1-164-159-11	CERAMIC 0.1MF 50V
C109	1-163-038-00	CERAMIC CHIP 0.1MF 25V	C313	1-164-159-11	CERAMIC 0.1MF 50V
C110	1-163-989-11	CERAMIC CHIP 0.033MF 10% 25V	C314	1-164-159-11	CERAMIC 0.1MF 50V
C111	1-131-367-00	TANTALUM 22MF 20% 16V	C315	1-164-159-11	CERAMIC 0.1MF 50V
C112	1-164-232-11	CERAMIC CHIP 0.01MF 10% 50V	C316	1-162-205-31	CERAMIC 18PF 5% 50V
C113	1-164-232-11	CERAMIC CHIP 0.01MF 10% 50V	C317	1-162-205-31	CERAMIC 18PF 5% 50V
C114	1-164-161-11	CERAMIC CHIP 0.0022MF 10% 50V	C318	1-124-997-11	ELECT 470MF 20% 10V
C115	1-164-161-11	CERAMIC CHIP 0.0022MF 10% 50V	C319	1-124-997-11	ELECT 470MF 20% 10V
C116	1-164-161-11	CERAMIC CHIP 0.0022MF 10% 50V	C320	1-130-481-00	MYLAR 0.0068MF 5% 50V
C117	1-163-038-00	CERAMIC CHIP 0.1MF 25V	C321	1-130-481-00	MYLAR 0.0068MF 5% 50V
C118	1-163-038-00	CERAMIC CHIP 0.1MF 25V	C322	1-130-471-00	MYLAR 0.001MF 5% 50V
C119	1-164-161-11	CERAMIC CHIP 0.0022MF 10% 50V	C323	1-130-471-00	MYLAR 0.001MF 5% 50V
C120	1-163-989-11	CERAMIC CHIP 0.033MF 10% 25V	C324	1-123-332-00	ELECT 47MF 20% 25V
C151	1-163-019-00	CERAMIC CHIP 0.0068MF 10% 50V	C325	1-123-332-00	ELECT 47MF 20% 25V
C152	1-163-038-00	CERAMIC CHIP 0.1MF 25V	C326	1-162-291-31	CERAMIC 560PF 10% 50V
C153	1-163-006-11	CERAMIC CHIP 560PF 10% 50V	C327	1-162-291-31	CERAMIC 560PF 10% 50V
C154	1-164-161-11	CERAMIC CHIP 0.0022MF 10% 50V	C328	1-124-893-11	ELECT 2200MF 20% 6.3V
C155	1-163-023-00	CERAMIC CHIP 0.015MF 10% 50V	C330	1-162-286-31	CERAMIC 220PF 10% 50V
C171	1-163-038-00	CERAMIC CHIP 0.1MF 25V	C331	1-162-286-31	CERAMIC 220PF 10% 50V
C172	1-163-038-00	CERAMIC CHIP 0.1MF 25V	C332	1-164-159-11	CERAMIC 0.1MF 50V
			C333	1-164-159-11	CERAMIC 0.1MF 50V
			C401	1-164-159-11	CERAMIC 0.1MF 50V
			C402	1-164-159-11	CERAMIC 0.1MF 50V

Ref.No.	Part No.	Description
C451	1-164-159-11	CERAMIC 0.1MF 50V
C503	1-162-291-31	CERAMIC 560PF 10% 50V
C504	1-162-291-31	CERAMIC 560PF 10% 50V
CN101	1-568-796-11	SOCKET, CONNECTOR 22P
CN102	1-568-795-11	SOCKET, CONNECTOR 12P
CN103	*1-564-721-11	PIN, CONNECTOR (SMALL TYPE) 5P
CN301	*1-564-707-11	PIN, CONNECTOR (SMALL TYPE) 5P
CN502	*1-564-337-00	PIN, CONNECTOR 3P
CNP201	*1-564-321-00	PIN, CONNECTOR 2P
CNP301	*1-568-933-11	SOCKET, CONNECTOR 30P
CNP302	*1-568-822-11	SOCKET, CONNECTOR 22P
CNP303	*1-564-337-61	PIN, CONNECTOR 3P
CNP401	*1-568-933-11	SOCKET, CONNECTOR 30P
D101	8-719-105-72	DIODE RD4.7M-B1
D201	8-719-200-82	DIODE 11ES2
D202	8-719-200-82	DIODE 11ES2
D203	8-719-200-82	DIODE 11ES2
D204	8-719-200-82	DIODE 11ES2
D205	8-719-200-82	DIODE 11ES2
D208	8-719-110-08	DIODE RD8.2ES-B2
D209	8-719-120-90	DIODE RD6.8ES-L3
D301	8-719-123-54	DIODE RD6.2ES-B2
D302	8-719-107-94	DIODE 1SS202-1
D401	8-719-933-57	DIODE HZS9B2L
D402	8-719-107-94	DIODE 1SS202-1
D403	8-719-107-94	DIODE 1SS202-1
D404	8-719-107-94	DIODE 1SS202-1
D405	8-719-107-94	DIODE 1SS202-1
D406	8-719-107-94	DIODE 1SS202-1
D407	8-719-107-94	DIODE 1SS202-1
D408	8-719-107-94	DIODE 1SS202-1
D409	8-719-107-94	DIODE 1SS202-1
D410	8-719-107-94	DIODE 1SS202-1
FLD401	1-519-556-11	INDICATOR TUBE, FLUORESCENT
IC101	8-752-037-33	IC CXA1372Q
IC102	8-759-821-94	IC LA6532M
IC103	8-759-633-65	IC M54641L
IC201	8-759-630-21	IC M5290P-16
IC202	8-759-633-42	IC M5293L
IC301	8-752-333-31	IC CXD2500Q
IC302	8-752-334-06	IC CXD2551P
IC303	8-759-917-18	IC SN74HC04M
IC304	8-759-998-22	IC PCM56P
IC305	8-759-998-22	IC PCM56P
IC306	8-759-631-39	IC M5204P
IC401	8-759-150-29	IC UPD75212AGF-522-3BE
IC451	8-749-920-83	IC GP1U52XB
J101	1-216-295-00	METAL GLAZE 0 5% 1/10W
J102	1-216-295-00	METAL GLAZE 0 5% 1/10W
J401	1-566-921-11	JACK, PIN 2P (LINE OUT L/R)
J501	1-568-519-21	JACK, LARGE TYPE (PHONES)
M101	X-4917-504-1	MOTOR ASSY (SLED)
M102	X-4917-523-3	MOTOR ASSY (SPINDLE)
M191	A-4604-363-A	MOTOR (L) ASSY
PS201A	1-532-685-00	LINK, IC
PS202A	1-532-637-00	LINK, IC
Q101	8-729-901-01	TRANSISTOR DTC144EK
Q201	8-729-111-67	TRANSISTOR 2SB1094-L
Q202	8-729-140-96	TRANSISTOR 2SD774-34

Ref.No.	Part No.	Description
Q203	8-729-111-67	TRANSISTOR 2SB1094-L
Q204	8-729-230-45	TRANSISTOR 2SC2458-YGR
Q206	8-729-119-76	TRANSISTOR 2SA1175-HFE
R101	1-216-097-00	METAL GLAZE 100K 5% 1/10W
R102	1-216-097-00	METAL GLAZE 100K 5% 1/10W
R103	1-216-091-00	METAL GLAZE 56K 5% 1/10W
R104	1-216-099-00	METAL GLAZE 120K 5% 1/10W
R105	1-216-069-00	METAL GLAZE 6.8K 5% 1/10W
R106	1-216-061-00	METAL GLAZE 3.3K 5% 1/10W
R107	1-216-114-00	METAL GLAZE 510K 5% 1/10W
R108	1-216-105-00	METAL GLAZE 220K 5% 1/10W
R109	1-216-061-00	METAL GLAZE 3.3K 5% 1/10W
R110	1-216-049-00	METAL GLAZE 1K 5% 1/10W
R111	1-216-049-00	METAL GLAZE 1K 5% 1/10W
R112	1-216-083-00	METAL GLAZE 27K 5% 1/10W
R113	1-216-071-00	METAL GLAZE 8.2K 5% 1/10W
R114	1-216-105-00	METAL GLAZE 220K 5% 1/10W
R152	1-216-073-00	METAL GLAZE 10K 5% 1/10W
R153	1-216-085-00	METAL GLAZE 33K 5% 1/10W
R154	1-216-085-00	METAL GLAZE 33K 5% 1/10W
R155	1-216-093-00	METAL GLAZE 68K 5% 1/10W
R156	1-216-081-00	METAL GLAZE 22K 5% 1/10W
R157	1-216-079-00	METAL GLAZE 18K 5% 1/10W
R158	1-216-079-00	METAL GLAZE 18K 5% 1/10W
R159	1-216-079-00	METAL GLAZE 18K 5% 1/10W
R160	1-216-049-00	METAL GLAZE 1K 5% 1/10W
R171	1-216-001-00	METAL GLAZE 10 5% 1/10W
R172	1-216-001-00	METAL GLAZE 10 5% 1/10W
R173	1-216-001-00	METAL GLAZE 10 5% 1/10W
R174	1-216-001-00	METAL GLAZE 10 5% 1/10W
R201	1-249-425-11	CARBON 4.7K 5% 1/4W
R202	1-249-425-11	CARBON 4.7K 5% 1/4W
R203	1-249-438-11	CARBON 56K 5% 1/4W
R204	1-249-429-11	CARBON 10K 5% 1/4W
R205	1-249-435-11	CARBON 33K 5% 1/4W
R208	1-249-423-11	CARBON 3.3K 5% 1/4W
R209	1-249-417-11	CARBON 1K 5% 1/4W
R210	1-249-417-11	CARBON 1K 5% 1/4W
R302	1-249-417-11	CARBON 1K 5% 1/4W
R303	1-249-417-11	CARBON 1K 5% 1/4W
R304	1-249-417-11	CARBON 1K 5% 1/4W
R305	1-249-417-11	CARBON 1K 5% 1/4W
R308	1-249-423-11	CARBON 3.3K 5% 1/4W
R309	1-249-423-11	CARBON 3.3K 5% 1/4W
R310	1-249-429-11	CARBON 10K 5% 1/4W
R311	1-249-429-11	CARBON 10K 5% 1/4W
R312	1-249-441-11	CARBON 100K 5% 1/4W
R313	1-249-417-11	CARBON 1K 5% 1/4W
R314	1-249-417-11	CARBON 1K 5% 1/4W
R315	1-249-420-11	CARBON 1.8K 5% 1/4W
R316	1-249-418-11	CARBON 1.2K 5% 1/4W
R317	1-249-417-11	CARBON 1K 5% 1/4W
R318	1-249-417-11	CARBON 1K 5% 1/4W
R319	1-249-417-11	CARBON 1K 5% 1/4W

Note:
The components identified by mark Δ or dotted line with mark Δ are critical for safety. Replace only with part number specified.

Note:
Les composants identifiés par une marque Δ sont critiques pour la sécurité. Ne les remplacer que par une pièce portant le numéro spécifié.

Ref.No.	Part No.	Description			
R320	1-249-413-11	CARBON	470	5%	1/4W
R326	1-249-411-11	CARBON	330	5%	1/4W
R327	1-249-417-11	CARBON	1K	5%	1/4W
R328	1-249-417-11	CARBON	1K	5%	1/4W
R329	1-249-417-11	CARBON	1K	5%	1/4W
R330	1-249-417-11	CARBON	1K	5%	1/4W
R331	1-249-427-11	CARBON	6.8K	5%	1/4W
R332	1-249-427-11	CARBON	6.8K	5%	1/4W
R337	1-249-417-11	CARBON	1K	5%	1/4W
R338	1-249-417-11	CARBON	1K	5%	1/4W
R339	1-249-413-11	CARBON	470	5%	1/4W
R341	1-249-441-11	CARBON	100K	5%	1/4W
R401	1-249-439-11	CARBON	68K	5%	1/4W
R402	1-249-435-11	CARBON	33K	5%	1/4W
R403	1-249-435-11	CARBON	33K	5%	1/4W
R404	1-249-435-11	CARBON	33K	5%	1/4W
R405	1-249-441-11	CARBON	100K	5%	1/4W
R406	1-249-425-11	CARBON	4.7K	5%	1/4W
R407	1-249-425-11	CARBON	4.7K	5%	1/4W
R501	1-249-402-11	CARBON	56	5%	1/4W
R502	1-249-402-11	CARBON	56	5%	1/4W
RV101	1-238-016-11	RES, ADJ, CARBON 10K			
RV102	1-238-016-11	RES, ADJ, CARBON 10K			
RV501	1-238-748-11	RES, VAR, CARBON 1K/1K (PHONE LEVEL)			
S101	1-572-085-11	SWITCH, LEAF (LIMIT)			
S191	1-572-086-11	SWITCH, LEAF (LOAD OUT)			
S192	1-572-086-11	SWITCH, LEAF (LOAD IN)			
S401	1-554-303-21	SWITCH, KEY BOARD (1)			
S402	1-554-303-21	SWITCH, KEY BOARD (6)			
S403	1-554-303-21	SWITCH, KEY BOARD (11)			
S404	1-554-303-21	SWITCH, KEY BOARD (▲)			
S405	1-554-303-21	SWITCH, KEY BOARD (2)			
S406	1-554-303-21	SWITCH, KEY BOARD (7)			
S407	1-554-303-21	SWITCH, KEY BOARD (12)			
S408	1-554-303-21	SWITCH, KEY BOARD (▶)			
S409	1-554-303-21	SWITCH, KEY BOARD (3)			
S410	1-554-303-21	SWITCH, KEY BOARD (8)			
S411	1-554-303-21	SWITCH, KEY BOARD (CHECK)			
S412	1-554-303-21	SWITCH, KEY BOARD (■)			
S413	1-554-303-21	SWITCH, KEY BOARD (4)			
S414	1-554-303-21	SWITCH, KEY BOARD (9)			
S415	1-554-303-21	SWITCH, KEY BOARD (CLEAR)			
S416	1-554-303-21	SWITCH, KEY BOARD (■)			
S417	1-554-303-21	SWITCH, KEY BOARD (5)			
S418	1-554-303-21	SWITCH, KEY BOARD (10)			

Ref.No.	Part No.	Description
S419	1-554-303-21	SWITCH, KEY BOARD (>12)
S420	1-554-303-21	SWITCH, KEY BOARD (TIME)
S421	1-554-303-21	SWITCH, KEY BOARD (EDIT/TIME FADE)
S422	1-554-303-21	SWITCH, KEY BOARD (TIME SET)
S423	1-554-303-21	SWITCH, KEY BOARD (CONTINUE)
S424	1-554-303-21	SWITCH, KEY BOARD (AUTO SPECE)
S425	1-554-303-21	SWITCH, KEY BOARD (◀◀)
S426	1-554-303-21	SWITCH, KEY BOARD (◀◀)
S427	1-554-303-21	SWITCH, KEY BOARD (SHUFFLE)
S428	1-554-303-21	SWITCH, KEY BOARD (REPEAT)
S429	1-554-303-21	SWITCH, KEY BOARD (▶▶)
S430	1-554-303-21	SWITCH, KEY BOARD (▶▶)
S431	1-554-303-21	SWITCH, KEY BOARD (PROGRAM)
S432	1-554-303-21	SWITCH, KEY BOARD (FADER)
S435	1-554-303-21	SWITCH, KEY BOARD (PEAK SEARCH)
S451	1-571-305-11	SWITCH, PUSH (1 KEY){POWER}
SW001▲	1-571-722-11	(E)...SWITCH, VOLTAGE SELECTION
T701 ▲	1-449-921-11	(US).....TRANSFORMER, POWER
T701 ▲	1-449-922-11	(AEP,AUS)...TRANSFORMER, POWER
T701 ▲	1-449-923-11	(E).....TRANSFORMER, POWER
X301	1-567-926-11	VIBRATOR, CRYSTAL (16.9MHz)
X401	1-567-819-11	VIBRATOR, CERAMIC (4MHz)

ACCESSORY & PACKING MATERIAL

1-465-281-11	REMOTE COMMANDER
1-559-533-11	CORD, CONNECTION
3-750-792-11	(E,AUS)...MANUAL, INSTRUCTION
3-750-792-21	(US).....MANUAL, INSTRUCTION
3-750-792-41	(AEP).....MANUAL, INSTRUCTION
3-750-792-51	(AEP).....MANUAL, INSTRUCTION
*3-795-629-11	(AEP)...INSTRUCTION
4-384-285-01	COVER, BATTERY
*4-925-389-01	CUSHION
*4-933-231-11	INDIVIDUAL CARTON

<p>Note: The components identified by mark ▲ or dotted line with mark ▲ are critical for safety. Replace only with part number specified.</p>	<p>Note: Les composants identifiés par une marque ▲ sont critiques pour la sécurité. Ne les remplacer que par une pièce portant le numéro spécifié.</p>
--	--