

CDP-195/295/491

SERVICE MANUAL



Photo : CDP-295

US Model
CDP-195/491

Canadian Model

AEP Model

E Model
CDP-195/295

UK Model
CDP-491

Australian Model
CDP-295

Model Name Using Similar Mechanism	CDP-291/391
CD Mechanism Type	CDM14-5BD1
Optical Pick-Up Block Type	BU-5BD1

SPECIFICATIONS

Compact disc player

Frequency response	2 Hz - 20 kHz \pm 0.5 dB
Signal to noise ratio	More than 100 dB
Dynamic range	More than 97 dB
Harmonic distortion	Less than 0.005%
Channel separation	More than 95 dB

Outputs

LINE OUT (phono jacks)	Output level 2 V (at 50 kilohms) Load impedance over 10 kilohms
PHONES (stereo phone jack)	Output level max. 10 mW Load impedance 32 ohms

General

	CDP-195/295/491
Power requirements	Model for Continental Europe 220 - 230 V AC, 50/60 Hz Model for Canada 120 V AC, 60 Hz Model for Australia 240 V AC, 50 Hz Model for other countries 110, 120, 220 or 240 V AC, adjustable, 50/60 Hz
Power consumption	12 W
Dimensions (approx., including projections)	430 \times 100 \times 280 mm (w/h/d) (17 \times 4 \times 11 $\frac{1}{8}$ inches)
Weight (approx.)	3.5 kg (7 lbs 12 oz)

Supplied accessories

Audio cord	1 (2 phono plugs - 2 phono plugs)
Remote commander (CDP-295/491)	1
R6(size AA) batteries (CDP-295/491)	2
AC plug adaptor (for some areas)	1

Remote commander RM-D295 (CDP-295/491)

Remote control system	Infrared control
Power requirements	3 V DC with two R6 (size AA) batteries
Dimensions	Approx. 40 \times 20 \times 175 mm (w/h/d) (1 $\frac{3}{4}$ \times $\frac{1}{2}$ \times 7 inches)
Weight	Approx. 95 g (4 oz) Including batteries

Design and specifications subject to change without notice.

CLASS 1 LASER PRODUCT
LUOKAN 1 LASERLAITE
KLASS 1 LASERAPPARAT

This Compact Disc player is classified as a CLASS 1 LASER product. The CLASS 1 LASER PRODUCT label is located on the rear exterior.

COMPACT DISC PLAYER
SONY[®]



SAFETY-RELATED COMPONENT WARNING!!

COMPONENTS IDENTIFIED BY MARK \triangle OR DOTTED LINE WITH MARK \triangle ON THE SCHEMATIC DIAGRAMS AND IN THE PARTS LIST ARE CRITICAL TO SAFE OPERATION. REPLACE THESE COMPONENTS WITH SONY PARTS WHOSE PART NUMBERS APPEAR AS SHOWN IN THIS MANUAL OR IN SUPPLEMENTS PUBLISHED BY SONY.

ATTENTION AU COMPOSANT AYANT RAPPORT À LA SÉCURITÉ!

LES COMPOSANTS IDENTIFIÉS PAR UNE MARQUE \triangle SUR LES DIAGRAMMES SCHÉMATIQUES ET LA LISTE DES PIÈCES SONT CRITIQUES POUR LA SÉCURITÉ DE FONCTIONNEMENT. NE REMPLACER CES COMPOSANTS QUE PAR DES PIÈCES SONY DONT LES NUMÉROS SONT DONNÉS DANS CE MANUEL OU DANS LES SUPPLÉMENTS PUBLIÉS PAR SONY.

PROTECTION OF EYES FROM LASER BEAM DURING SERVICING

This set employs a laser. Therefore, be sure to follow carefully the instructions below when servicing.

CAUTION
Use of controls or adjustments or performance of procedures other than those specified herein may result in hazardous radiation exposure.

NOTES ON HANDLING THE OPTICAL PICK-UP BLOCK OR BASE UNIT

The laser diode in the optical pick-up block may suffer electrostatic breakdown because of the potential difference generated by the charged electrostatic load, etc. on clothing and the human body. During repair, pay attention to electrostatic breakdown and also use the procedure in the printed matter which is included in the repair parts.

The flexible board is easily damaged and should be handled with care.

1. Laser Diode Properties
 - Material: GaAlAs
 - Wavelength: 780nm
 - Emission Duration: continuous
 - Laser Output: max.44.6 μ W*
 - * This output is the value measured at a distance of about 200mm from the objective lens surface on the Optical Pick-up Block.
2. During service, do not take the Optical Pick-up Block apart, and do not adjust the APC circuit. If there is a breakdown in the APC circuit (including laser diode), replace the entire Optical Pick-up Block (including APC board).

TABLE OF CONTENTS

<u>Section</u>	<u>Title</u>	<u>Page</u>	<u>Section</u>	<u>Title</u>	<u>Page</u>
1. GENERAL		4	4-2. Block Diagram		10
Location of Controls		4	4-3. Waveforms		13
2. ELECTRICAL BLOCK CHECKING		5	4-4. Printing Wiring Boards		14
3. DISASSEMBLY OF BASE UNIT		7	4-5. Schematic diagram		17
4. DIAGRAMS		8	4-6. Semiconductor Lead Layouts		21
4-1. Pin Function of IC101 and IC401		8	4-7. IC Block Diagrams		22
			5. EXPLODED VIEWS		24
			6. ELECTRICAL PARTS LIST		28

MODEL IDENTIFICATION

- SPECIFICATION LABEL -

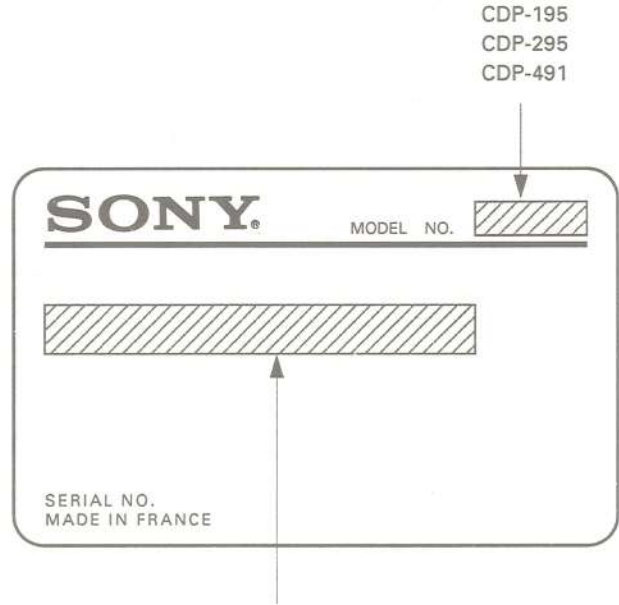
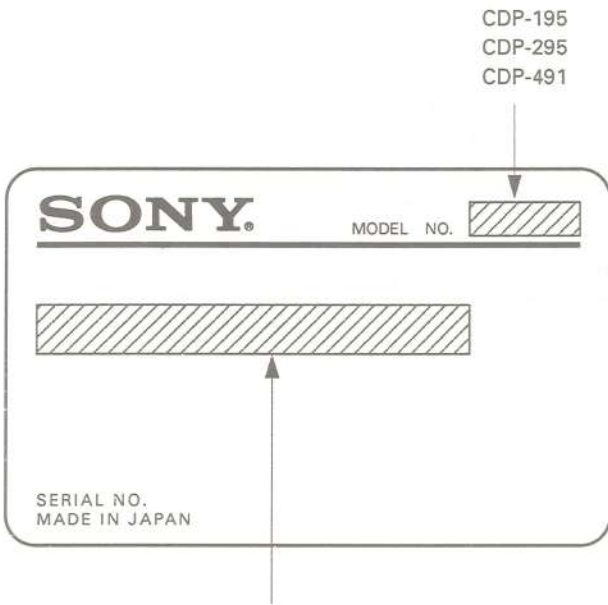

US, Canadian MODEL: AC120, 60Hz 12W
 AEP MODEL: AC220-230V, 50/60Hz
 Australian MODEL: AC240V, 50/60Hz
 E, Saudi Arabian MODEL: AC110-120, 220-240V, 50/60Hz, 12W

AEP MODEL: AC220-230V, 50/60Hz
 UK MODEL: AC240V, 50/60Hz

SAFETY CHECK-OUT

After correcting the original service problem, perform the following safety check before releasing the set to the customer: Check the antenna terminals, metal trim, "metallized" knobs, screws, and all other exposed metal parts for AC leakage. Check leakage as described below.

LEAKAGE TEST

The AC leakage from any exposed metal part to earth ground and from all exposed metal parts to any exposed metal part having a return to chassis, must not exceed 0.5mA (500 microamperes). Leakage current can be measured by any one of three methods.

1. A commercial leakage tester, such as the Simpson 229 or RCA WT-540A. Follow the manufacturers' instructions to use these instruments.
2. A battery-operated AC milliammeter. The Data Precision 245 digital multimeter is suitable for this job.

3. Measuring the voltage drop across a resistor by means of a VOM or battery-operated AC voltmeter. The "limit" indication is 0.75V, so analog meters must have an accurate low-voltage scale. The Simpson 250 and Sanwa SH-63Trd are examples of a passive VOM that is suitable. Nearly all battery operated digital multimeters that have a 2V AC range are suitable. (See Fig.A)

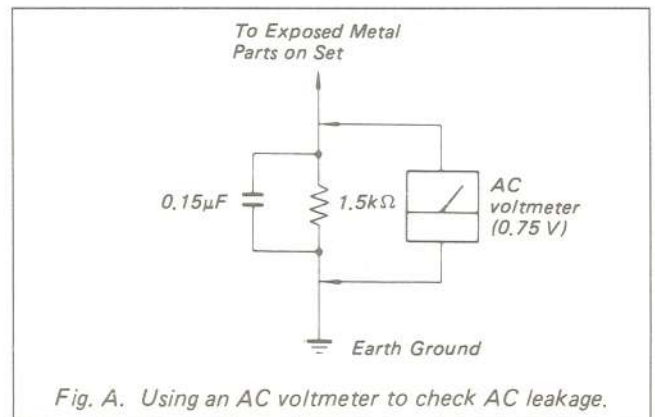

Fig. A. Using an AC voltmeter to check AC leakage.

SECTION 1

GENERAL

LOCATION OF CONTROLS

This section is extracted from instruction manual.

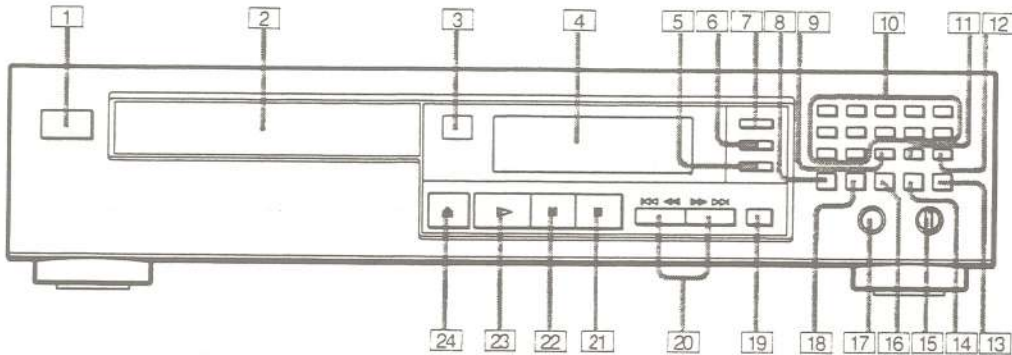

CDP-295

- 1 POWER switch
- 2 Disc tray
- 3 Remote sensor
- 4 Display window
- 5 PROGRAM button
- 6 SHUFFLE button
- 7 CONTINUE button
- 8 TIME button
- 9 CHECK (program check) button
- 10 Numeric buttons
- 11 CLEAR (program clear) button
- 12 > 12 (over 12) button
- 13 MUSIC SCAN button
- 14 PEAK SEARCH button
- 15 PHONE LEVEL control
- 16 FADER button
- 17 PHONES jack
- 18 REPEAT button
- 19 EDIT/TIME FADE button
- 20 ◀◀◀◀/▶▶▶▶ (AMS*/RMS**/manual search) buttons
- 21 ■ (stop) button
- 22 || (pause) button
- 23 ▶ (play) button
- 24 ▲ (open/close) button

* AMS is the abbreviation of Automatic Music Sensor.
 ** RMS is the abbreviation of Random Music Sensor.

SECTION 2

ELECTRICAL BLOCK CHECKING

Note :

1. CD Block basically constructed to operate without adjustment. Therefore, check each item in order given.
2. Use YEDS-18 disc (3-702-101-01) unless otherwise indicated.
3. Use the oscilloscope with more than $10M\Omega$ impedance.
4. Clean an object lens by an applicator with neutral detergent when the signal level is low than specified value with the following checks.

S Curve Check

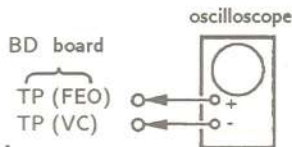

Procedure :

1. Connect oscilloscope to test point TP (FEO) on BD board.
2. Connect between test point TP (FES) and TP (VC) by lead wire.
3. Turned Power switch on and actuate the focus serch. (actuate the focus serch when disc table is moving in and out.)
4. Check the oscilloscope waveform (S curve) is symmetrical between A and B. And confirm peak to peak level within $3 \pm 1V_{p-p}$.

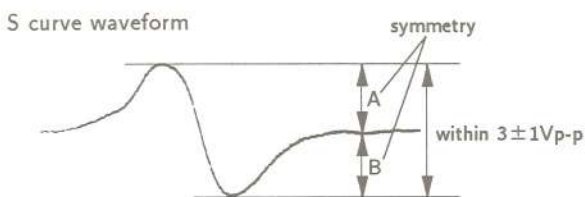

5. After check, remove the lead wire connected in step 2.

Note : • Try to mesure several times to make sure that the ratio of A : B or B : A is more than 10 : 7.

- Take sweep time as long as possible and light up the brightness to obtain best waveform.

RF Level Check

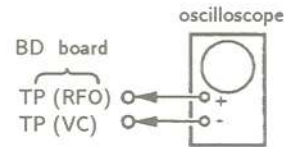

Procedure :

1. Connect oscilloscope to test point TP (RFO) on BD board.
2. Turn Power switch on.
3. Put disc (YEDS-18) in and playback.
4. Confirm that oscilloscope waveform is clear and check RF signal level is correct or not.

Note :

Clear RF signal waveform means that the shape “◇” can be clearly distinguished at the center of the waveform.

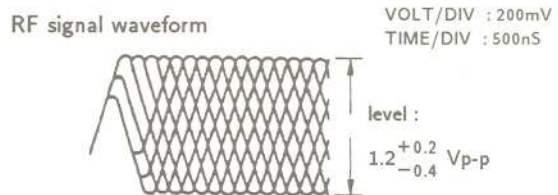

E-F Balance Check

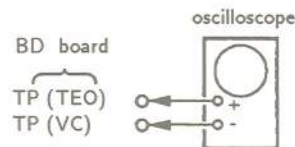

Procedure :

1. Connect test point TP (ADJ) to ground and TP (TES) to TP (VC) with lead wire.
2. Connect oscilloscope to test point TP (TEO) on BD board.
3. Turn Power switch on.
4. Put disc (YEDS-18) in and playback.
5. Confirm that the osilloscope waveform is symmetrical on the top and bottom in relation to 0V, and check this level.

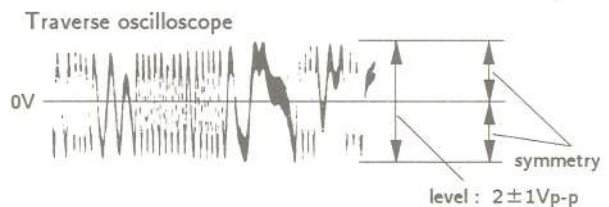

6. Remove the lead wire connected in step 1.

RF PLL Free-run Frequency Check

Procedure :

1. Connect frequency counter to test point (PLCK) with lead wire.

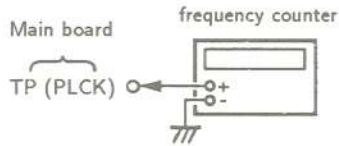

2. Turn Power switch on.
3. Confirm that reading on frequency counter is
4. 3218MHz.

Focus/Tracking Gain

This gain has a margin, so even if it is slightly off. There is no problem.

Therefore, do not perform, this adjustment.

Please note that it should be fixed to mechanical center position when you moved and do not know original position.

Adjustment Location ;

[MAIN BOARD] – Component Side –

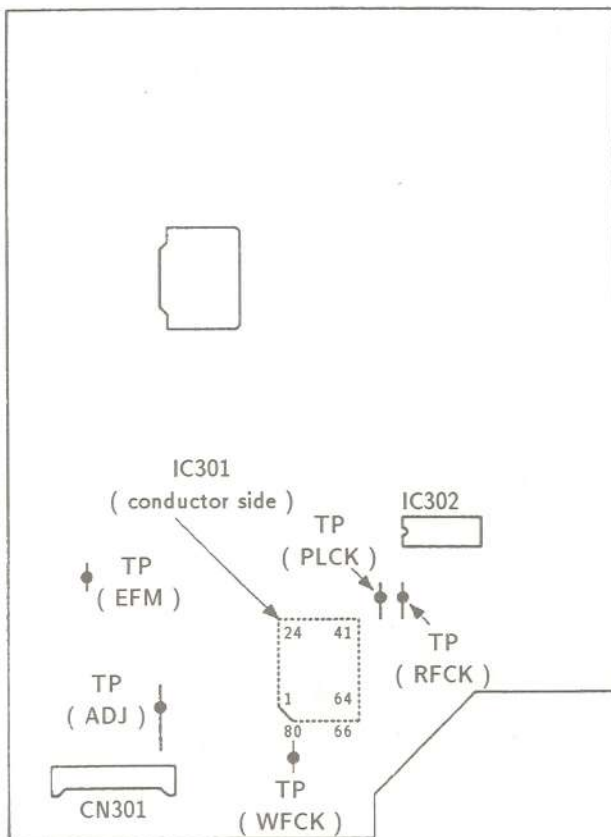

[BD BOARD] – Component Side –

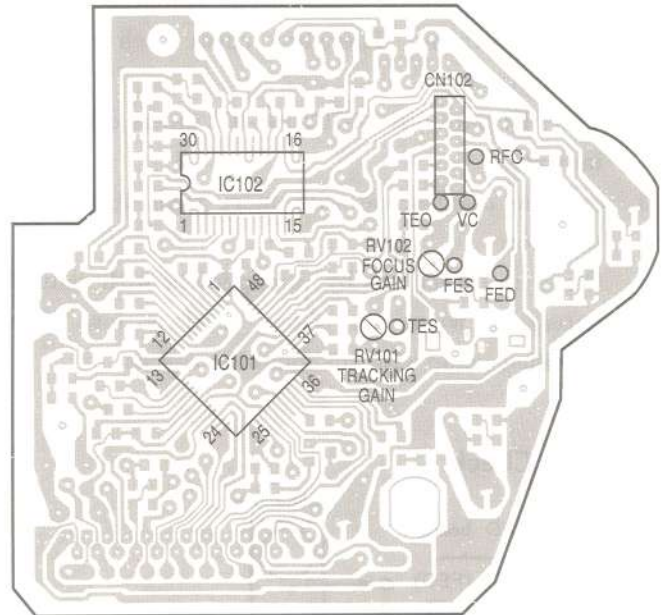

SECTION 3 DISASSEMBLY

Note :

Follow the disassembly procedure in the numerical order given.

- ① Turn the cam to the direction of arrow (Counter clock wise) by minus screw driver.
- ② Take off the disc table.
- ③ Remove the yoke bracket.
- ④ Remove the MD (BU-5BD1) to the direction of arrow.

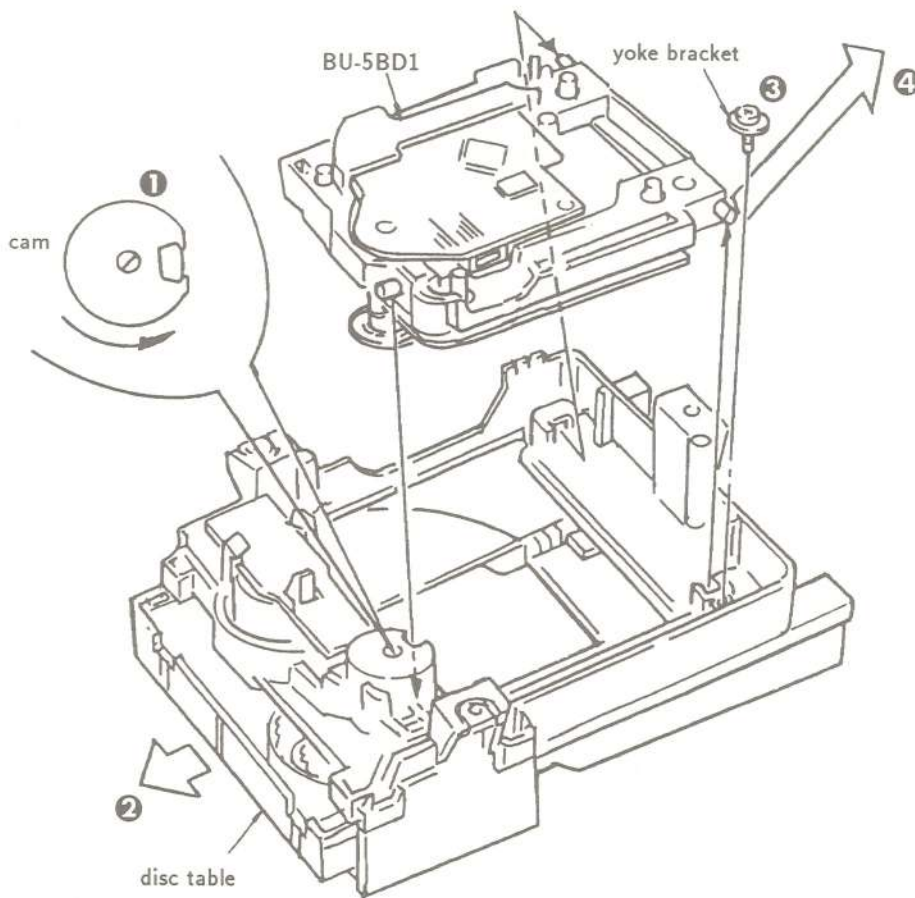

SECTION 4 DIAGRAMS

4-1. PIN FUNCTION OF IC101 AND IC401

● IC101 (CXA1372Q) PIN FUNCTION

Pin No.	Pin Name	I/O	Description
1	VC	—	GND when two (\pm) dual power supplies are in use, or the center voltage (2.5V) when a single power supply is in use.
2	FGD	I	Time constants for gain switching in normal mode/down mode and for focus gain are connected between the FGD and FS3 pins.
3	FS3	I	
4	FLB	I	The capacitor for low frequency boost in the focus servo loop is connected.
5	FEO	O	Focus drive output.
6	FE—	I	Inverted input to focus amplifier.
7	SRCH	I	Time constants to generate the focus search waveform are connected.
8	TGU	I	Time constants for gain switching in normal mode/up mode and for tracking gain are connected between TGU pin and TG2 pin.
9	TG2	I	
10	AVCC	—	Analog power supply (5V when \pm dual power supplies are in use, 5V when a single power supply is in use.)
11	TAO	O	Tracking drive output.
12	TA—	I	Inverted input to tracking amplifier.
13	SL+	I	Non-inverted input to sled amplifier.
14	SLO	O	Sled drive output.
15	SL—	I	Non-inverted input to sled amplifier.
16	ESET	I	The 610k Ω phase compensator resistor is connected to this pin.
17	ISET	I	The current setting resistor is connected to this pin.
18	SSTOP	I	The limit switch is connected to this pin.
19	AVEE	—	Analog power supply (–5V when \pm dual power supplies are in use, or GND when a single power supply is in use.)
20	DIRC	I	Direct control pin.
21	LOCK	I	Sled run-away prevention circuit operates when this signal is "L".
22	CLK	I	Serial data transfer clock input that is supplied from CPU (or DSP).
23	XLT	I	Latch input from CPU (or DSP).
24	DATA	I	Serial data input from CPU (or DSP).
25	XRST	I	System reset. "L" to reset.
26	C.OUT	O	Output to tracking counter.
27	SENS	O	SENS output.
28	DGND	—	Digital ground (GND). (GND when \pm dual power supplies are in use. GND when a single power supply is in use.)
29	MIRR	O	Mirror output.
30	DFCT	O	Defect output. "H" when defective.
31	ASY	I	Auto-assymmetry control input.
32	EFM	O	EFM comparator output.
33	FOK	O	Focus OK.
34	CC2	I	Defect-bottom-hold input (input by capacitive coupling).
35	CC1	O	Defect-bottom-hold output.
36	DVCC	—	Digital power supply. (+5V when \pm dual power supplies in use. +5V when a single power supply is in use.)
37	CB	I	The defect-bottom-hold capacitor is connected to this pin.
38	CP	I	The mirror hold capacitor is connected to this pin.
39	RF1	I	RF signal input (input by capacitive coupling).
40	RF0	I	RF signal input (input by DC coupling).
41	DVEE	—	Digital power supply (–5V when \pm dual power supplies are in use. GND when a single power supply is in use.)
42	TZC	I	Tracking zero-cross comparator input.
43	TE	I	Tracking error input.
44	TDFCT	I	The defect prevention hold capacitor is connected to this pin.
45	ATSC	I	Anti-shock input.
46	FZC	I	Focus zero-cross comparator input.
47	FE	I	Focus error input.
48	FDFCT	I	The defect prevention hold capacitor is connected to this pin.

● IC401 (CXP50112-097Q) PIN FUNCTION

Pin No.	Pin Name	I / O	Description
1 - 4	—	—	Not used (open).
5 - 20	S1 - S16	O	Segment output to FL tube.
21 - 28	1G - 8G	O	Common output to FL tube.
29	SCOR	I	Subcode sync signal S0 + S1 detection input from IC301 (CXD2500AQ).
30	—	—	Not used (open).
31	+5V	—	+5V
32	RST	I	Reset input.
33	+5V	—	+5V
34	VDD	—	Power voltage terminal (+5V).
35 - 40	KEY0 - KEY5	I	Key A/D input.
41	—	—	Not used (Ground).
42	TIMER SW	I	Auto play select input (Auto play "L").
43	—	—	Not used (Ground).
44	CLK	O	Serial data transfer clock output to IC301 (CXD2500AQ).
45	DATA	O	Serial data output to IC301 (CXD2500AQ).
46	—	—	Not used (Ground).
47	FOK	I	Focus OK signal input from IC101 (CXA1372Q).
48	GFS	I	Frame sync signal clock status input from IC301 (CXD2500AQ).
49	SUBQ	I	Sub code (Q data) serial input from IC301 (CXD2500AQ).
50	SQCLK	O	Sub code (Q data) readout clock output to IC301 (CXD2500AQ).
51	XLT	O	Serial data latch output.
52	PRGL	O	Attenuate data latch clock output to IC302 (CXD2554P).
53	LDON	O	Laser diode ON/OFF select output of optical pick-up.
54	AMUT	O	Muting output for IC301 (CXD2500AQ) and Q344 (2SC3399). Muting on by "H", Muting off by "L".
55 - 58	B0 - B3	—	Not used (+5V)
59	DEFECT SW	O	Defect circuit ON/OFF select output to IC101 (CXA1372Q).
60	—	—	Not used (open).
61	SENSE	I	SENS signal input from IC301 (CXD2500AQ).
62	RMC	I	Remote control signal input.
63	INSW	I	Input for loading out switch.
64	OUTSW	I	Output for loading in switch.
65	ADJ	I	Tset mode input. GFS check will not activate by "L".
66	AFADJ	I	Test mode input. All test operation will be activate by "L" mode when power on.
67	LODIN	O	Output for turn the loading motor to loading.
68	LODOUT	O	Output for turn the loading motor to un loading.
69	—	—	Not used (open).
70	—	—	Not used (open).
71	Vss	—	Ground.
72	XTAL	O	Clock output.
73	+5V	—	+5V
74	EXTAL	I	Clock input. (4MHz)
75	+5V	—	+5V
76	-30V	I	Power voltage -30V for built in FL tube controller.
77	—	—	Not used (open).
78	—	—	Not used (open).
79	—	—	Not used (open).
80	—	—	Not used (open).

4-2. BLOCK DIAGRAM

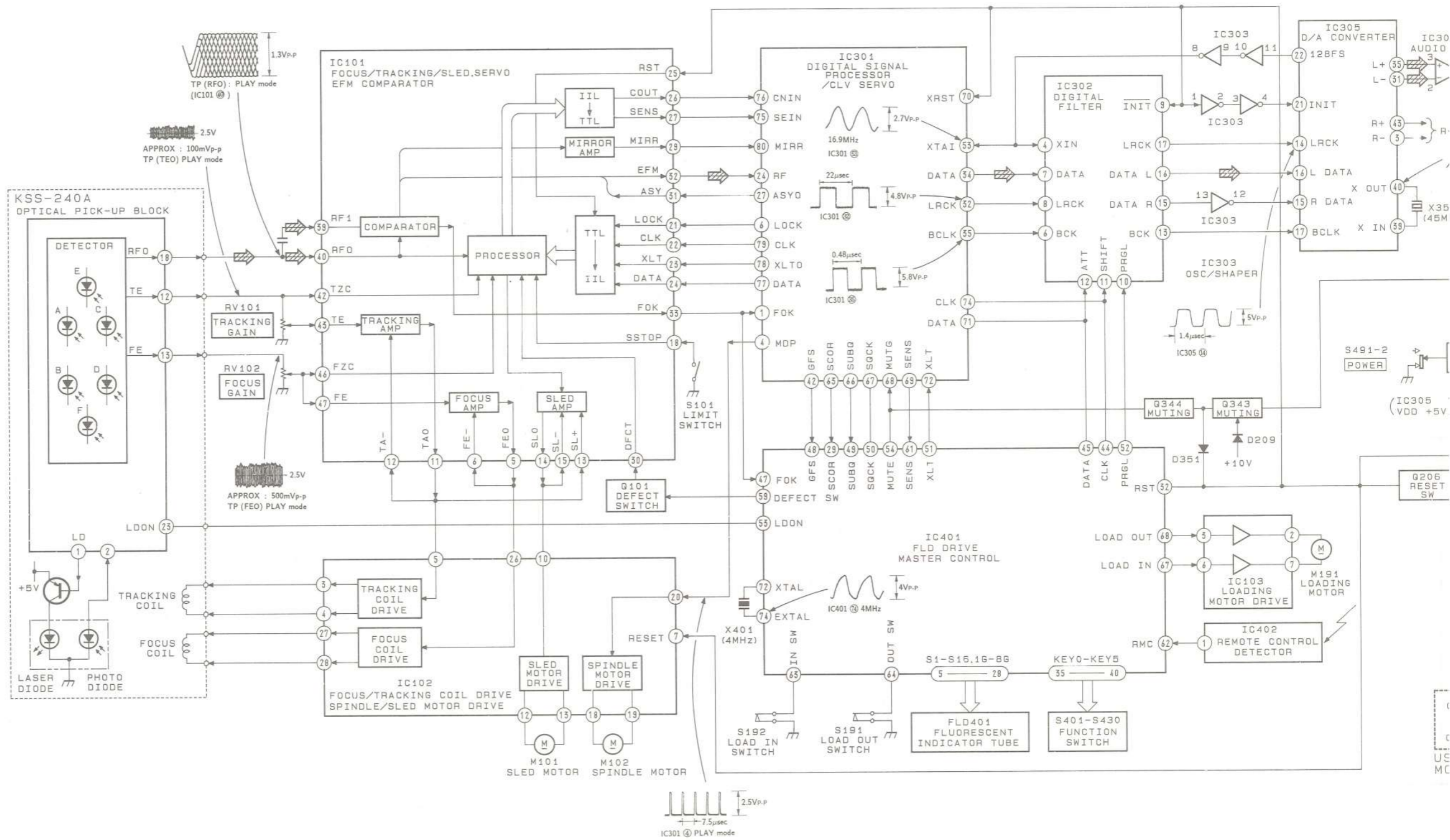

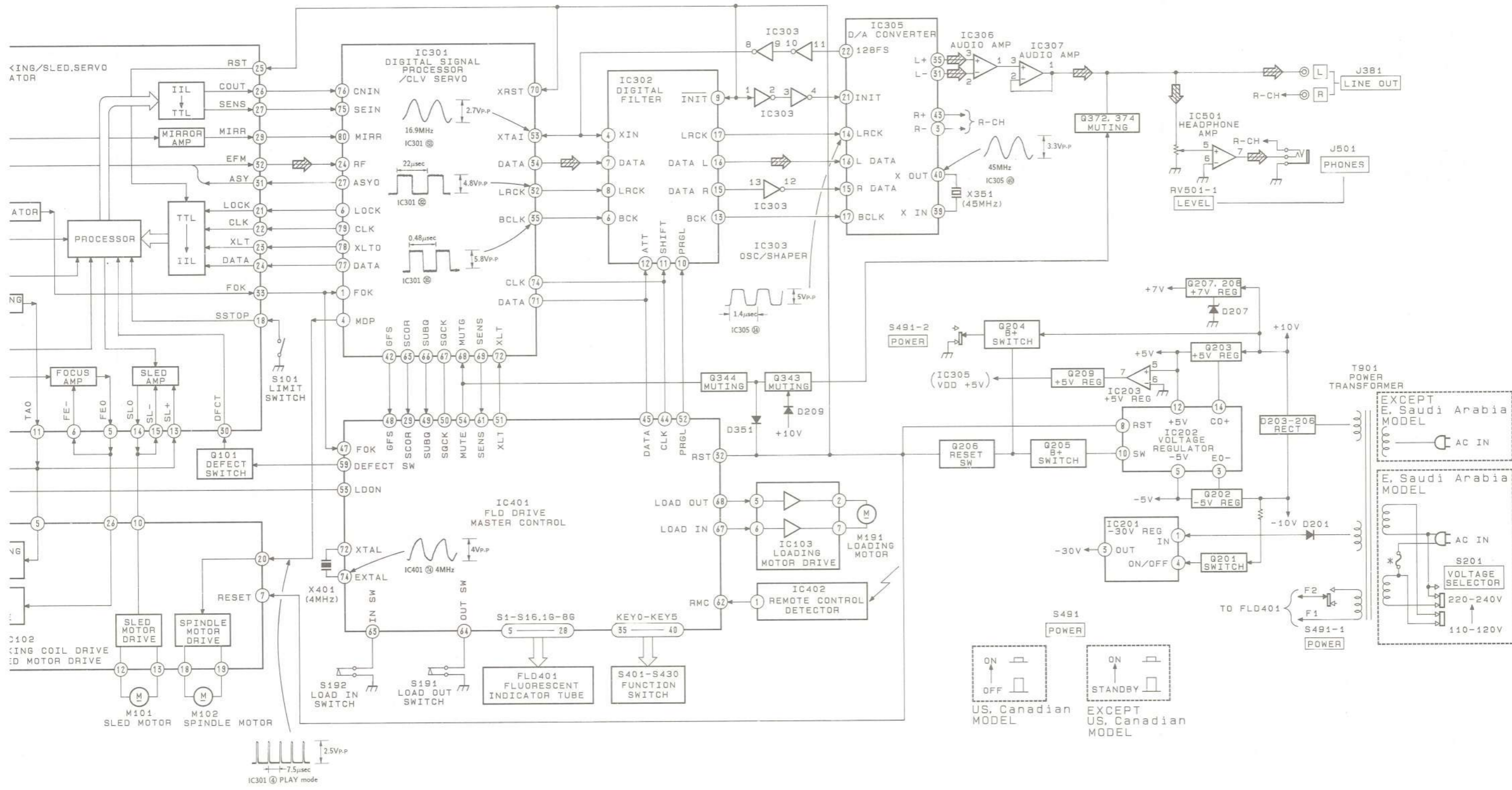

4-3. WAVEFORMS

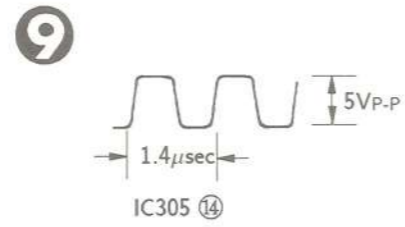
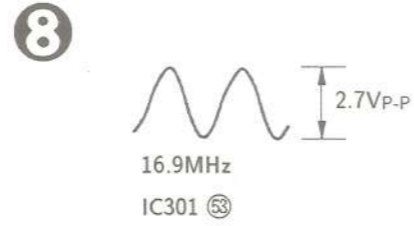
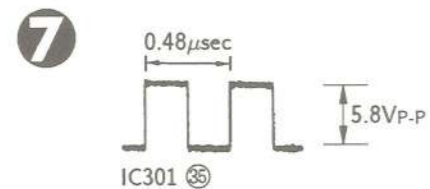
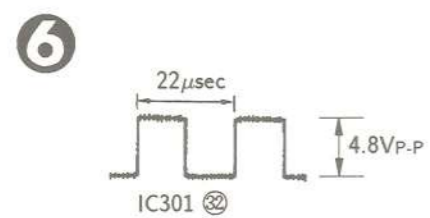
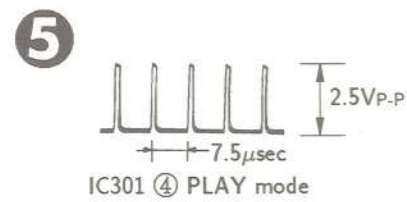
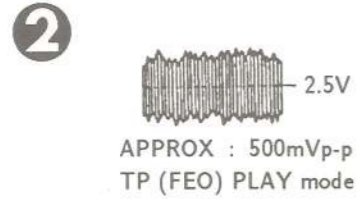
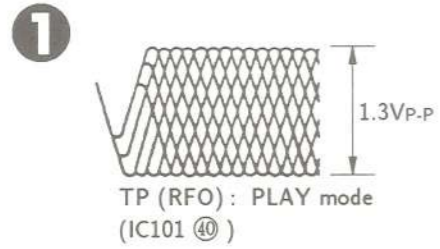

• SEMICONDUCTOR LOCATION

Ref. No.	LOCATION No.	Ref. No.	LOCATION No.
D101	F-3	IC306	D-14
D201	E-18	IC307	C-14
D202	I-18	IC401	C-4
D203	E-17	IC402	C-1
D204	E-17	IC501	G-10
D205	E-17		
D206	E-17	Q101	I-3
D207	G-18	Q201	F-18
D208	F-16	Q202	G-17
D209	F-16	Q203	F-17
D341	F-15	Q204	H-17
D351	G-13	Q205	H-17
		Q206	H-17
		Q207	G-18
IC101	H-2	Q208	G-18
IC102	G-2	Q209	F-15
IC103	F-3	Q343	D-13
IC201	F-18	Q344	G-12
IC202	G-17	Q371	B-14
IC203	G-15	Q372	C-15
IC301	H-15	Q373	B-14
IC302	G-14	Q374	C-15
IC303	G-13		
IC305	E-14		

Note:

- : indicated a lead wire mounted on the component side.
- : parts mounted on the conductor side.
- : Through hole.
- ▨ : Pattern from the side which enables seeing.
- (shaded) : Pattern of the rear side.

Semiconductor Lead Layouts is inserted on P21.

4-4. PRINTED WIRING BOARDS

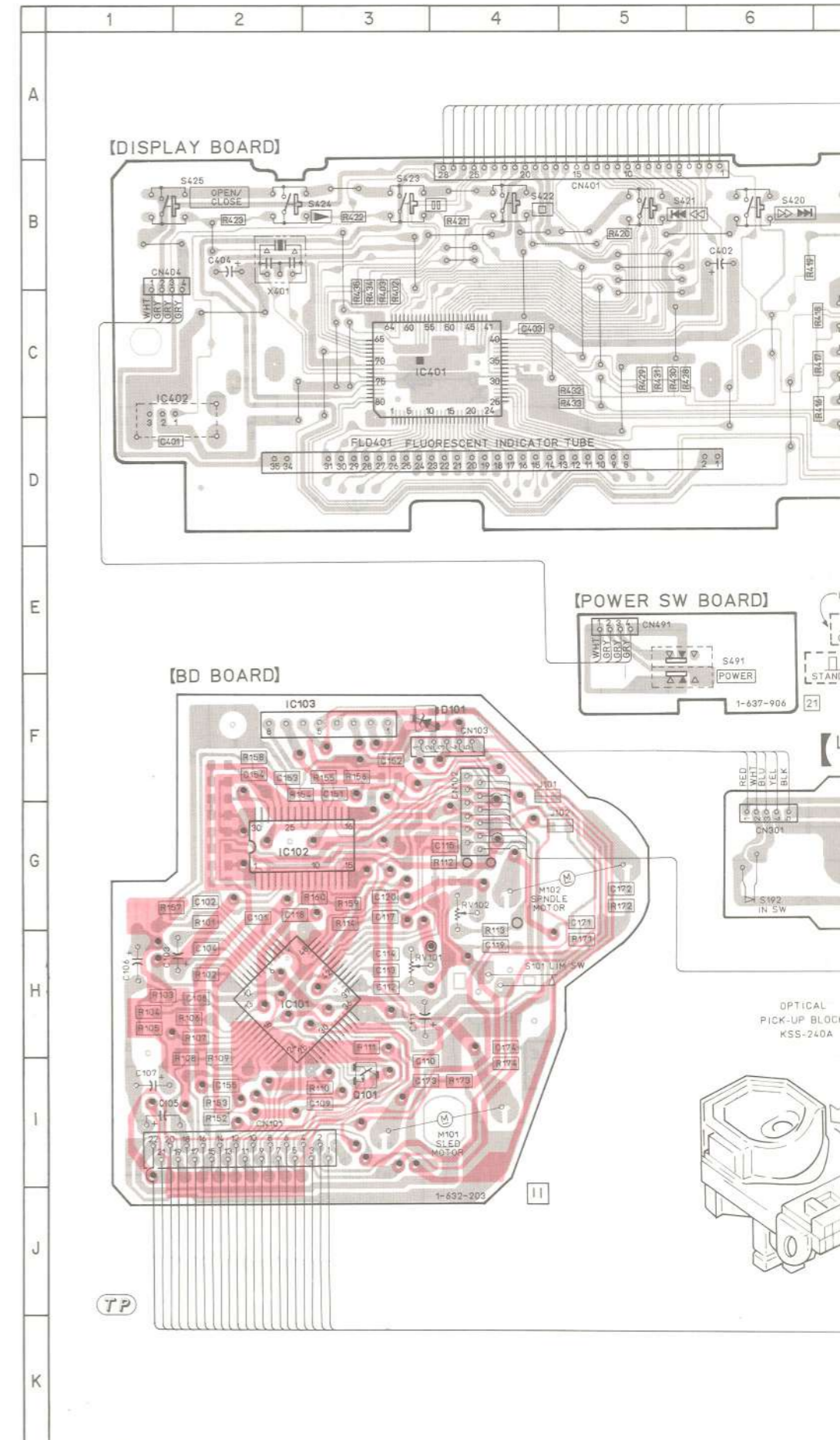

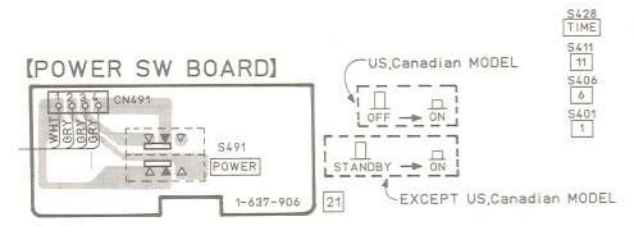
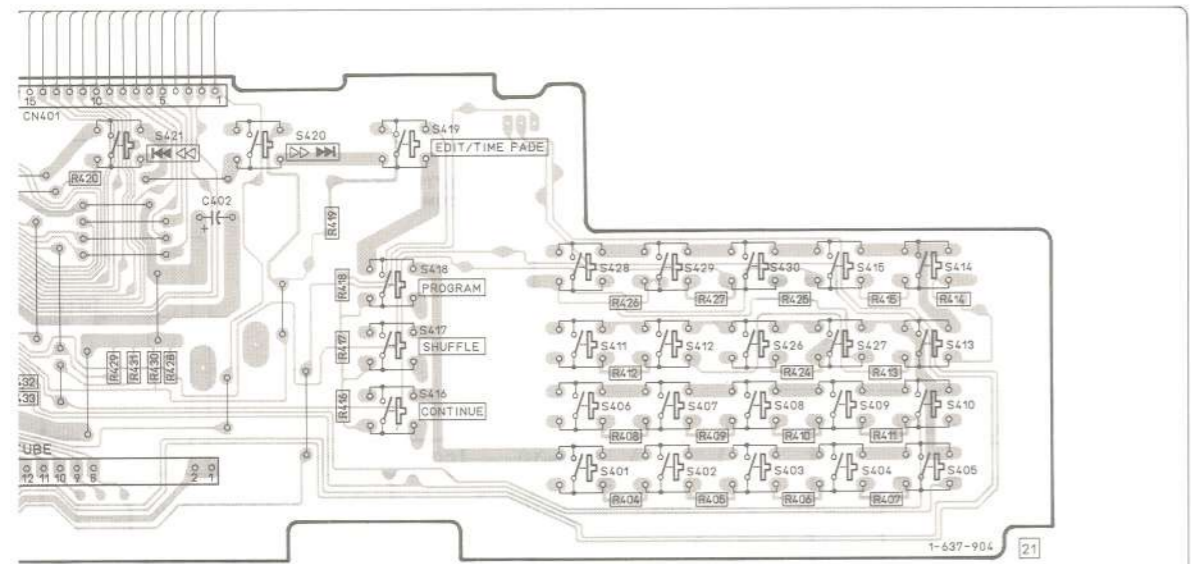

S428	S429	S430	S415	S414
TIME	REPEAT	FADER	PEAK SEARCH	MUSIC SCAN
S411	S412	S426	S427	S413
11	12	CHECK	CLEAR	> 12
S406	S407	S408	S409	S410
6	7	8	9	10
S401	S402	S403	S404	S405
1	2	3	4	5

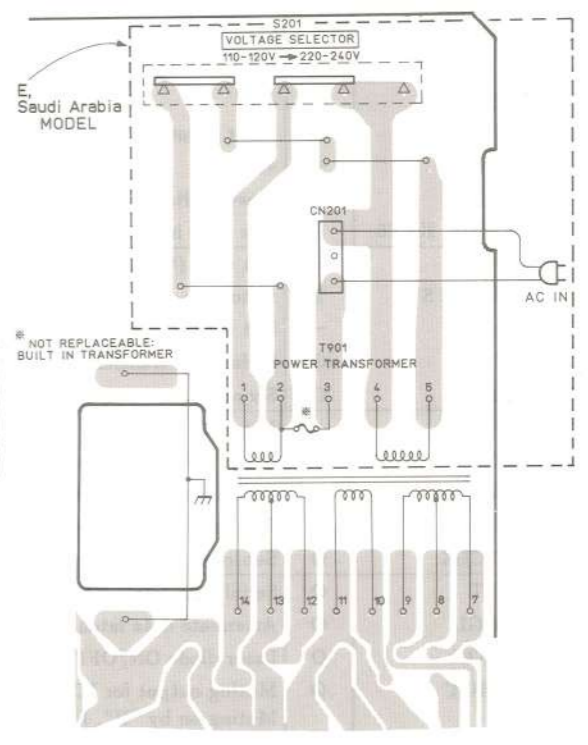
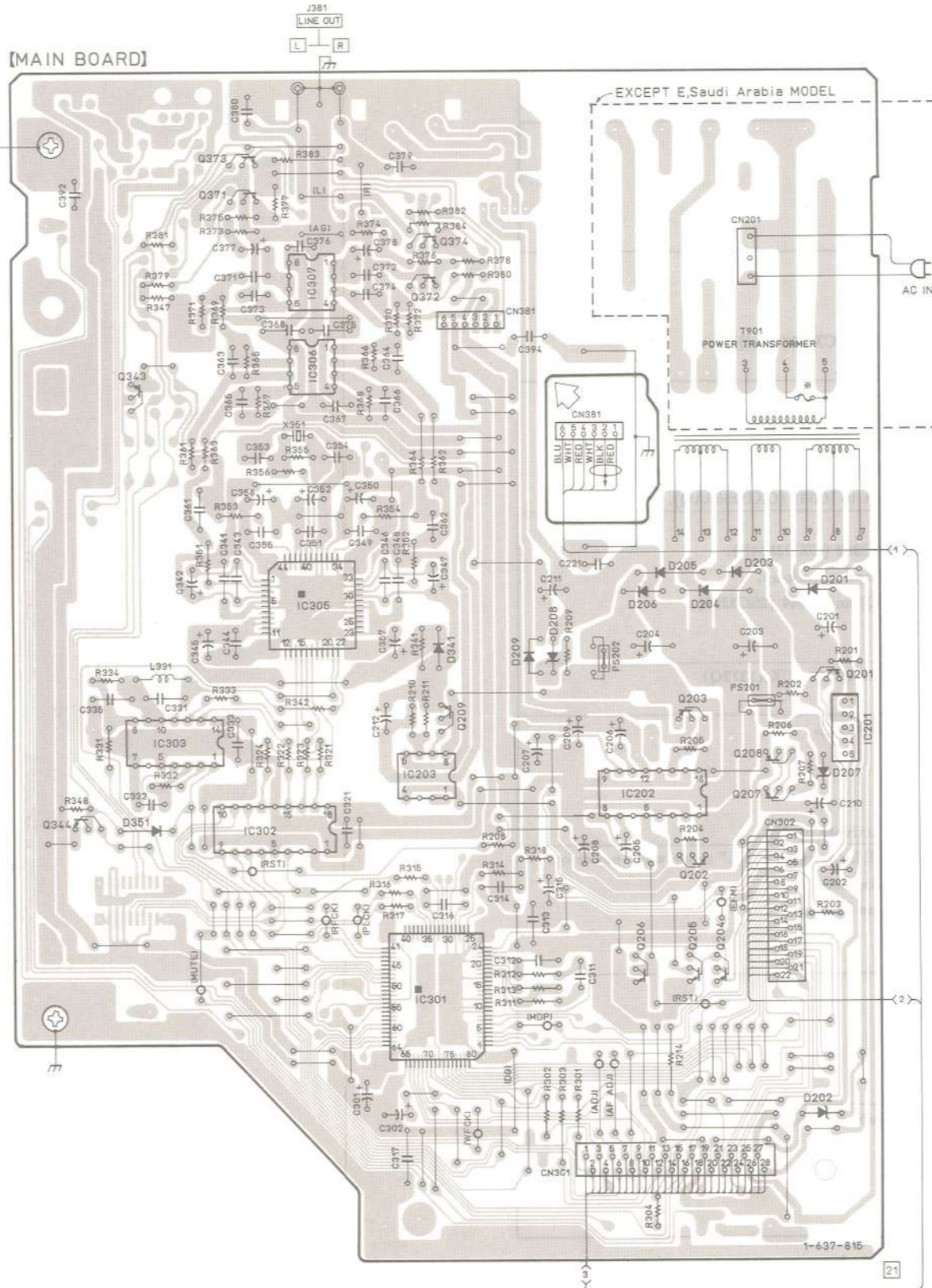
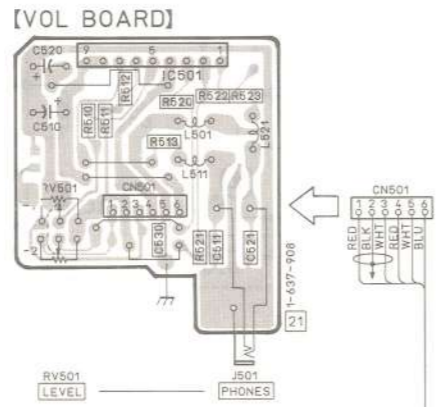
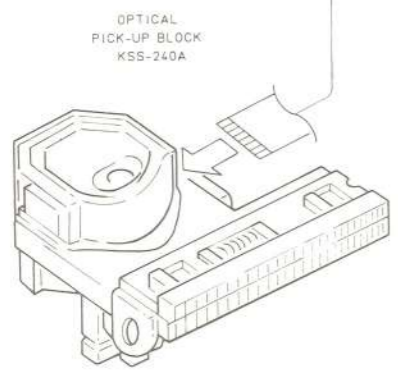
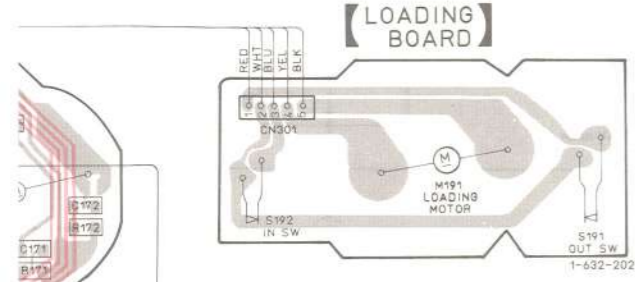

4-5. SCHEMATIC DIAGRAM

Note:

- All capacitors are in μF unless otherwise noted. pF: μF 50WV or less are not indicated except for electrolytics and tantalums.
- All resistors are in ohms, 1/4W or less unless otherwise noted.
- Δ : internal component.

The components identified by mark Δ or dotted line with mark Δ are critical for safety.
Replace only with part number specified.

Les composants identifiés par une marque Δ sont critiques pour la sécurité.
Ne les remplacer que par une pièce portant le numéro spécifié.

- — : B+ Line.
- - - - : B- Line.
- : adjustment for repair.
- Voltages are DC between measurement points and ground under no-signal (STOP) conditions.
- no make : PB mode
- Voltages are taken with a VOM (input impedance 10M Ω). Voltage variations may be noted due to normal production tolerances.
- Waveforms are taken with a oscilloscope. Voltage variations may be noted due to normal production tolerances.
- Circled numbers refer to waveforms.
- Signal path : CD

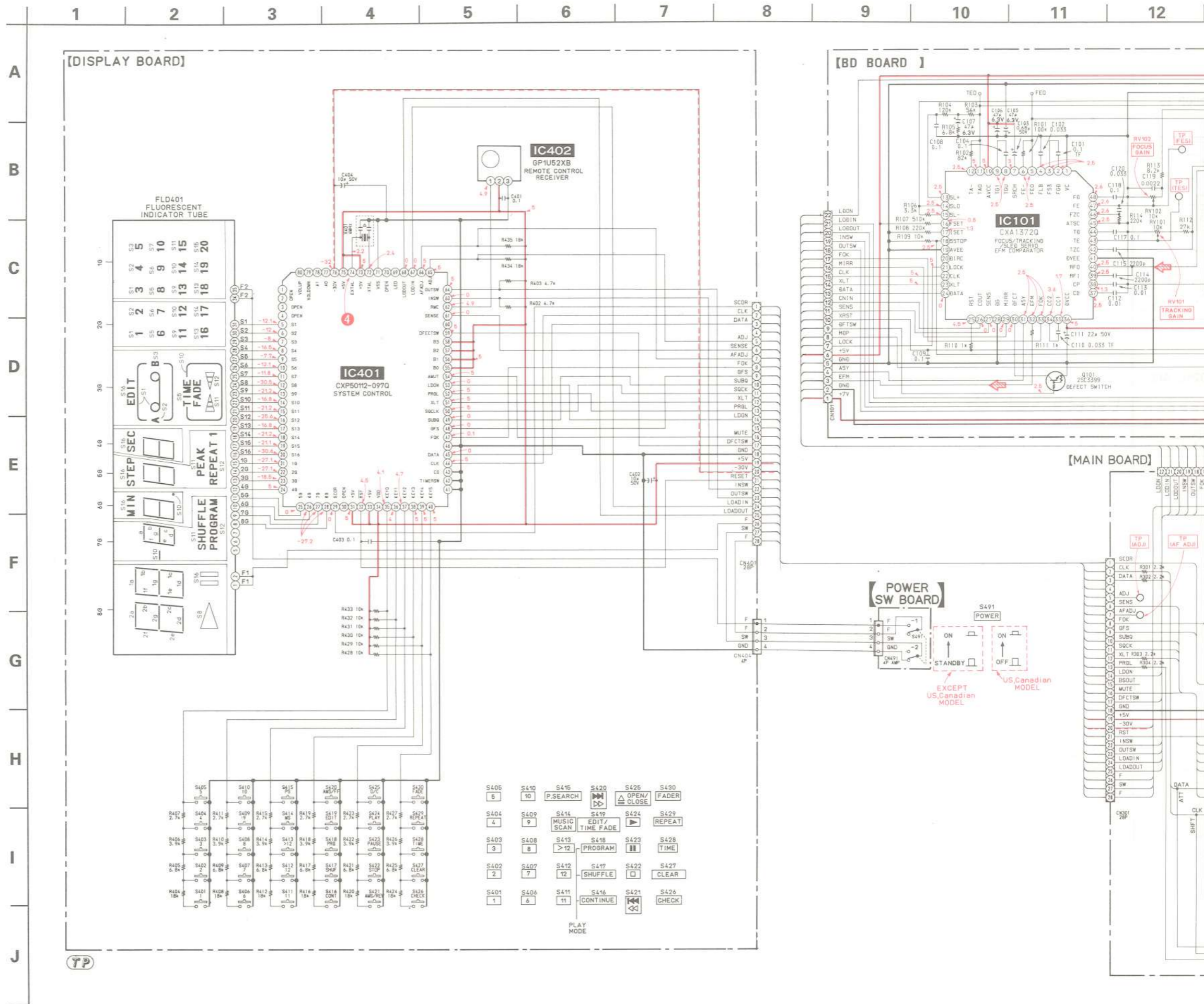

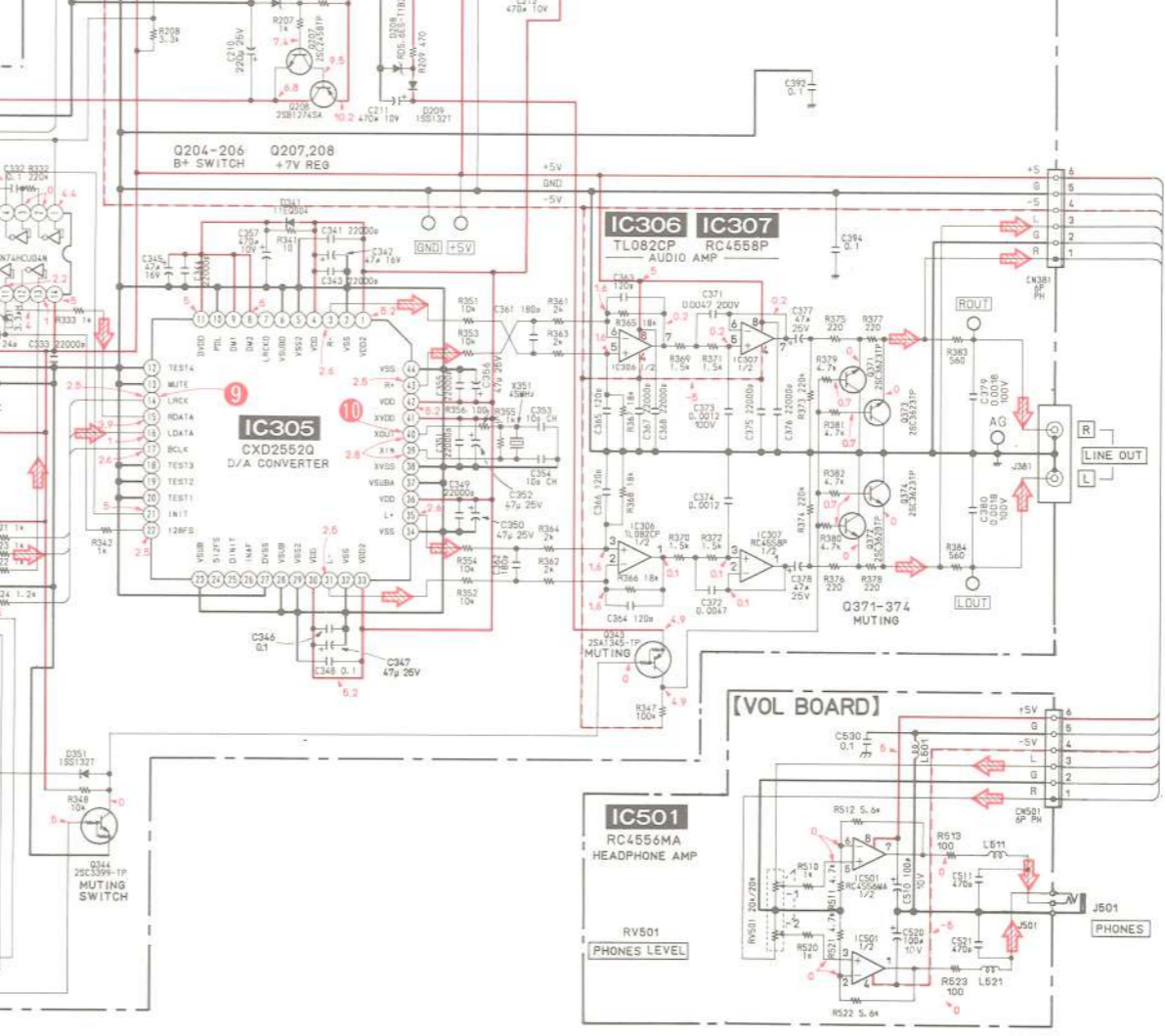
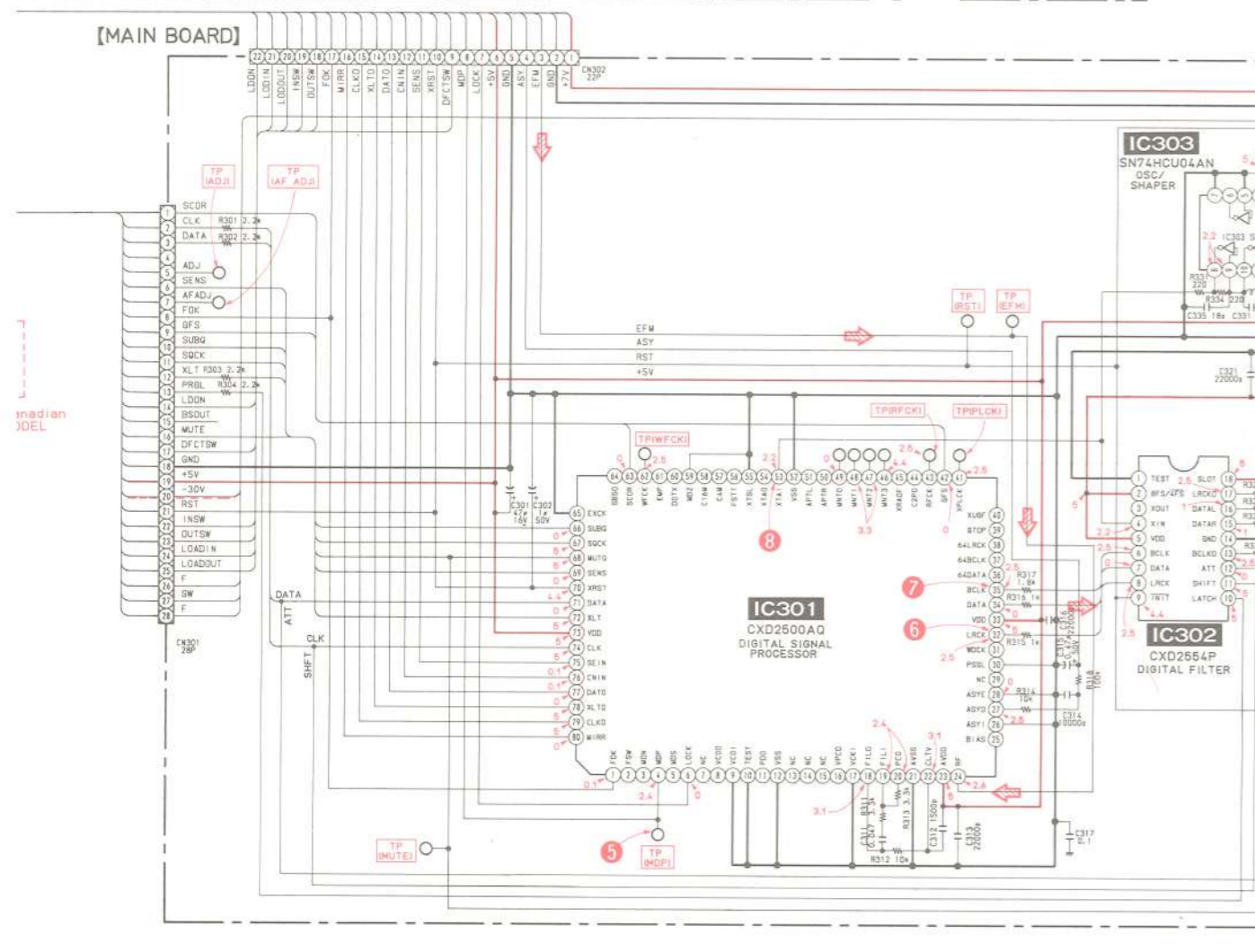
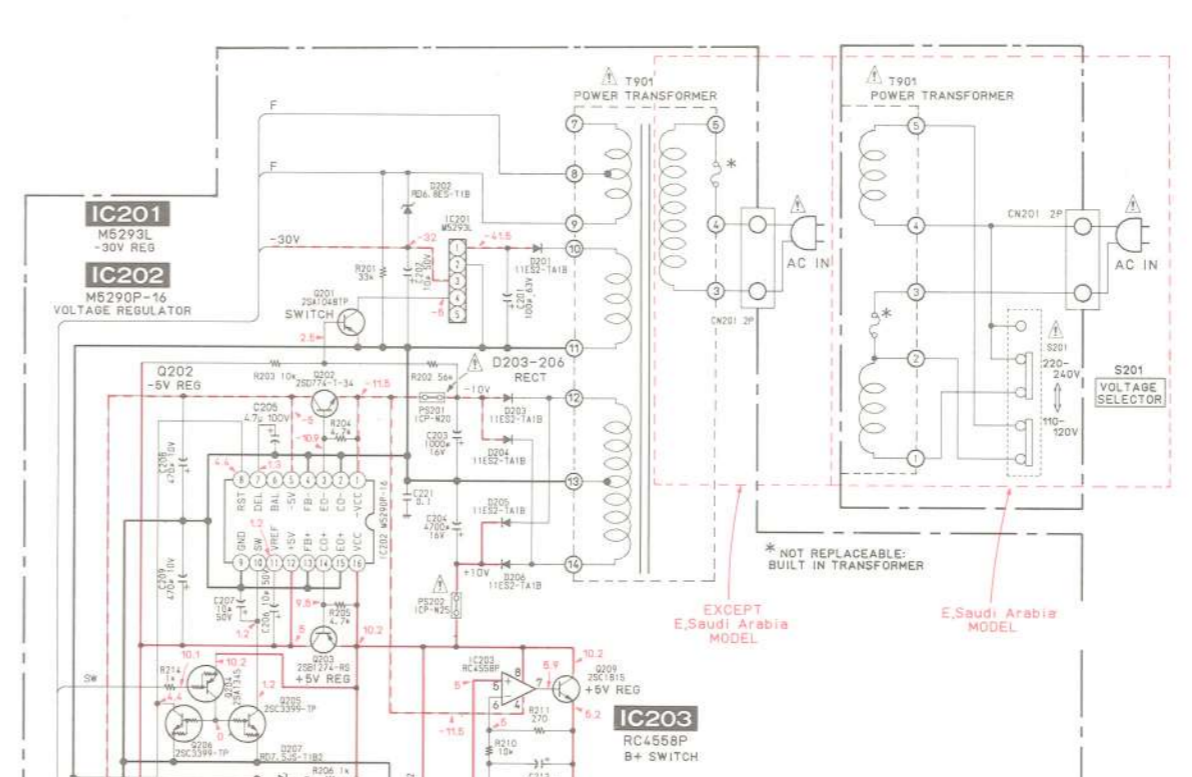
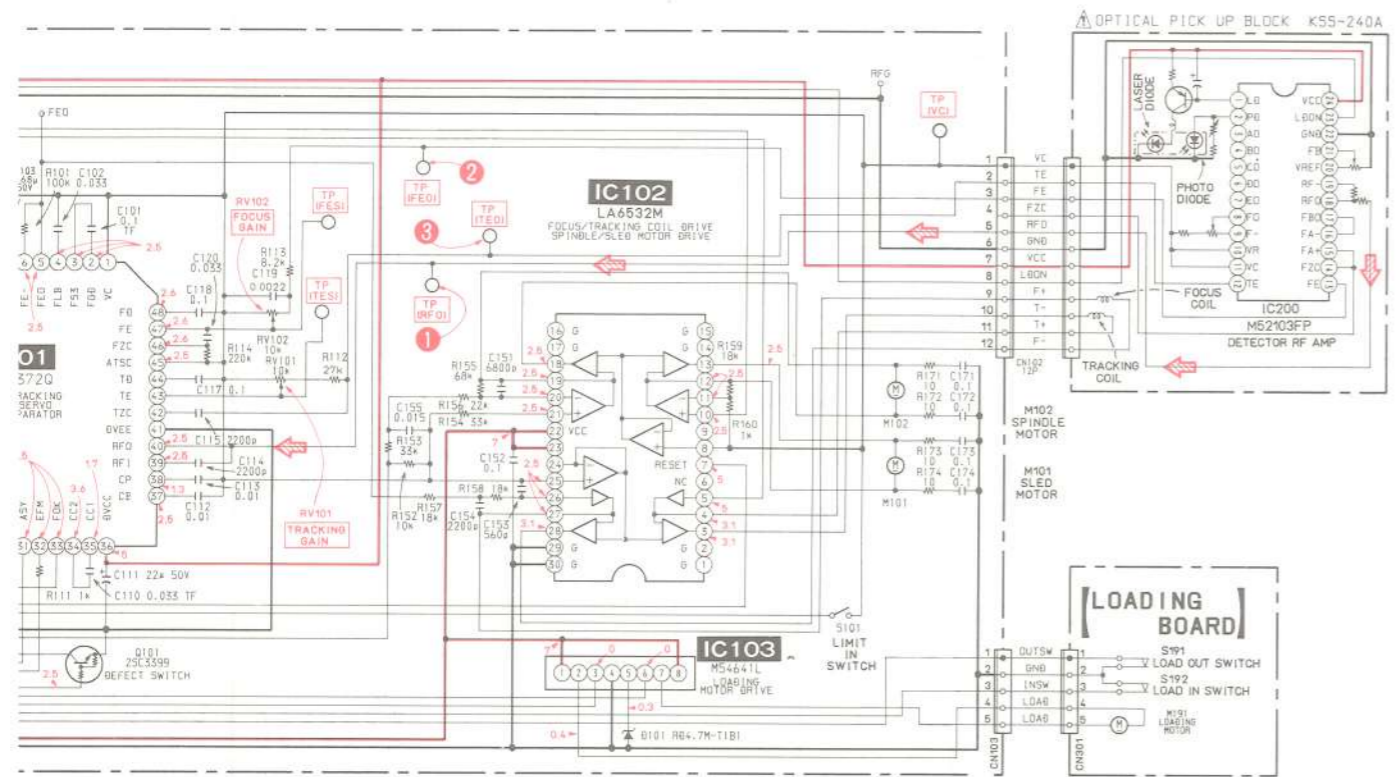

4-6. SEMICONDUCTOR LEAD LAYOUTS

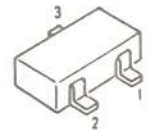
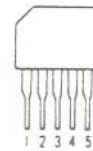
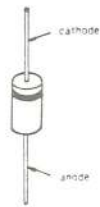
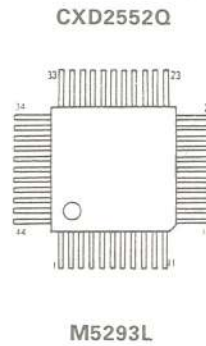
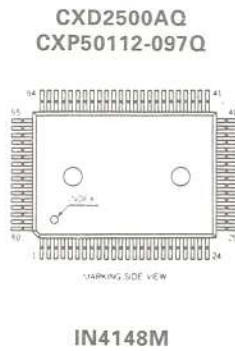
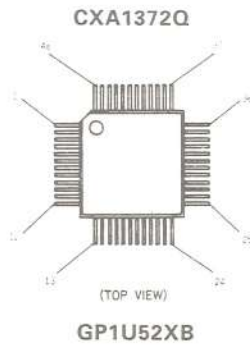

RD5.6ES-B2
RD6.8ES-B1
RD7.5JS-B2
ISS202-1
11ES2
11EQS04



2SA1175-HFE



2SB1094-L
2SB1274SA-RS



2SC1815-Y



2SD774-34

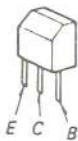

4-7. IC BLOCK DIAGRAMS

IC101 CXA1372Q

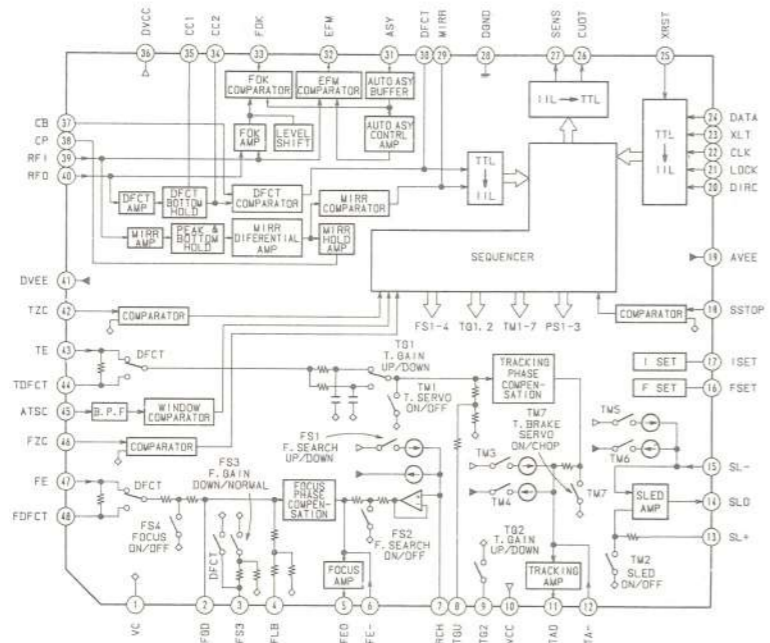

IC103 M54641L

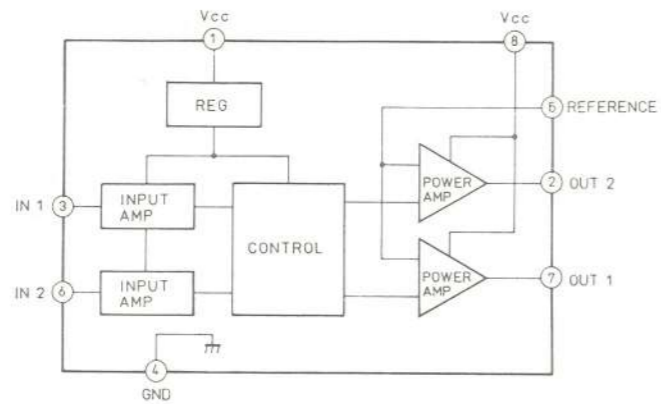

IC201 M5293L

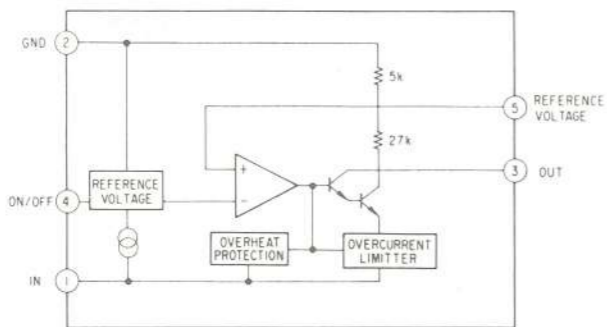

IC202 M5290P-16

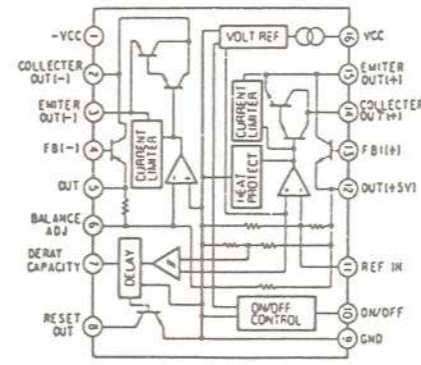

IC301 CXD2500AQ

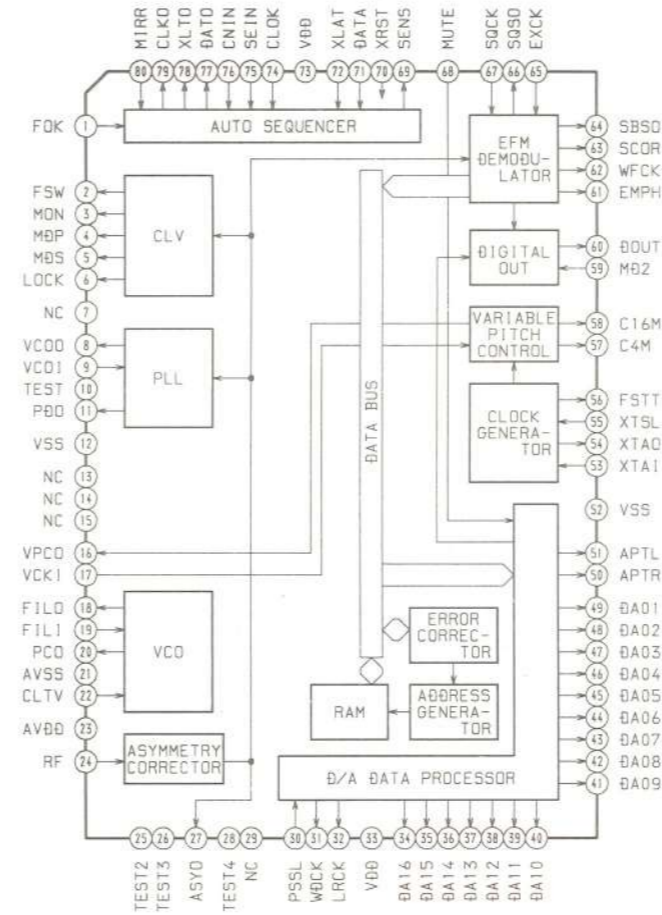

IC302 CXD2554P

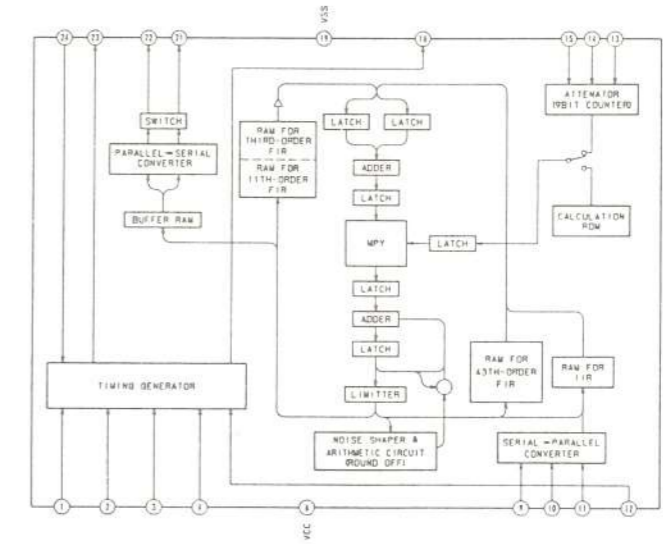

IC305 CXD2552AQ

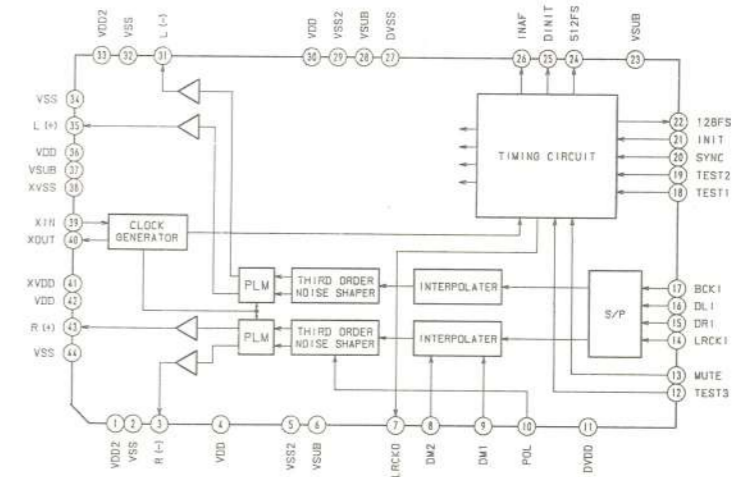

SECTION 5 EXPLODED VIEW

NOTE:

- -XX, -X mean standardized parts, so they may have some differences from the original one.
- The construction parts of an assembled part are indicated with a collation number in the remark column.
- Color Indication of Appearance Parts
Example:
KNOB,BALANCE(WHITE)...(RED)
↑ ↑
Parts color Cabinet's color
- Items marked "*" are not stocked since they are seldom required for routine service. Some delay should be anticipated when ordering these items.
- The mechanical parts with no reference number in the exploded views are not supplied.
- Hardware(# mark) list is given in the last of this parts list.

The components identified by mark Δ or dotted line with mark Δ are critical for safety.
Replace only with part number specified.

Les composants identifiés par une marque Δ sont critiques pour la sécurité.
Ne les remplacer que par une pièce portant le numéro spécifié.

(1) CABINET SECTION

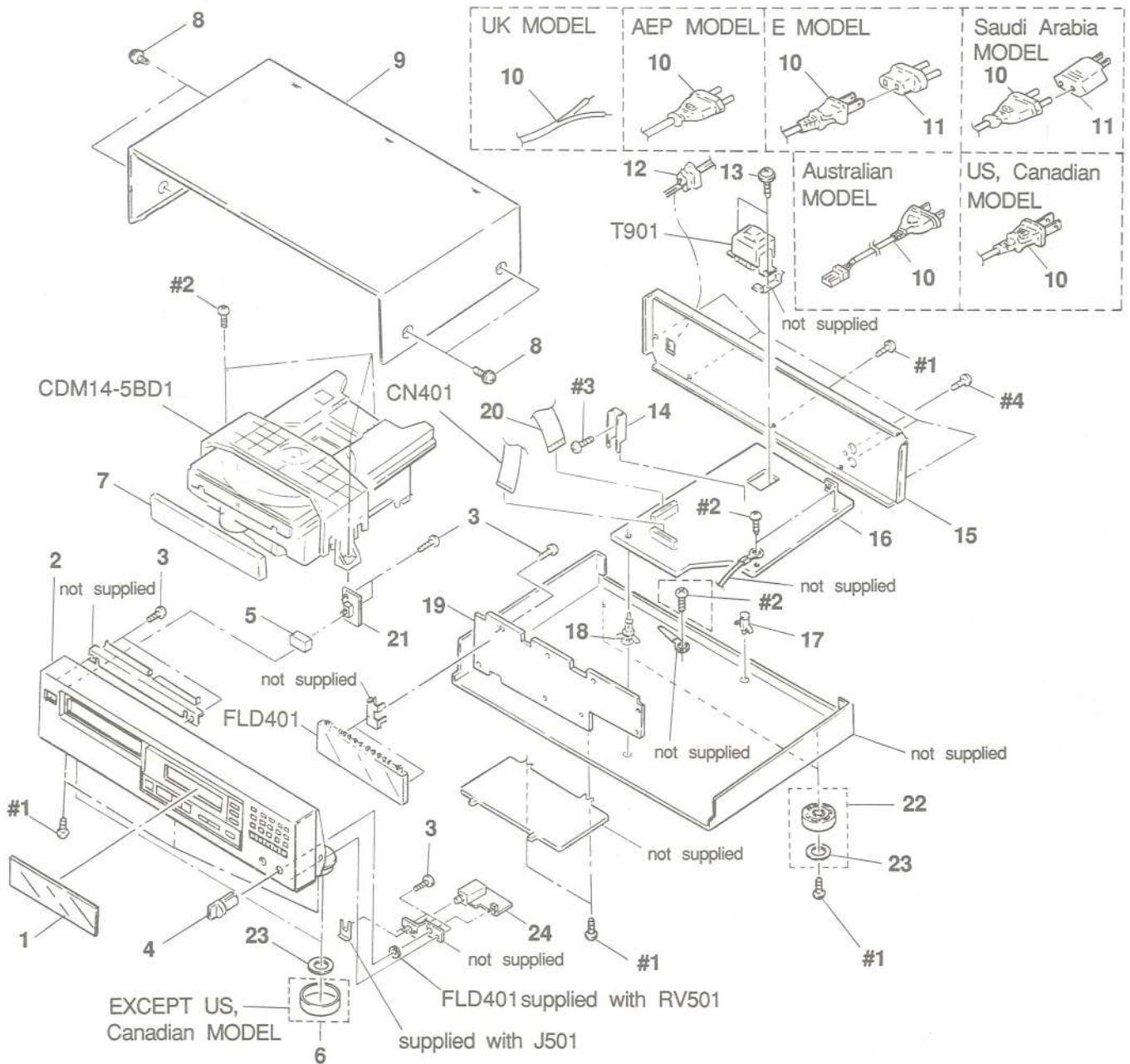

Ref. No.	Part No.	Description	Remark
1	4-942-767-11	PLATE, INDICATION (195)	
1	4-942-767-01	PLATE, INDICATION (295/491)	
2	X-4941-260-1	PANEL ASSY, FRONT (MADE IN FRANCE 295:AEP)	
2	X-4941-262-1	PANEL ASSY, FRONT (MADE IN JAPAN 195:AEP, E. Saudi Arabia, Australian)	
2	X-4941-261-1	PANEL ASSY, FRONT (MADE IN JAPAN 195:US, Canadian)	
2	X-4941-263-1	PANEL ASSY, FRONT (MADE IN FRANCE 195:AEP)	
2	X-4941-259-1	PANEL ASSY, FRONT (MADE IN JAPAN 295:AEP, E. Australian)	
2	X-4941-258-1	PANEL ASSY, FRONT (MADE IN JAPAN 295:Canadian)	
2	X-4941-430-1	PANEL ASSY, FRONT (MADE IN JAPAN 491:US)	
2	X-4941-456-1	PANEL ASSY, FRONT (MADE IN FRANCE 491:UK)	
3	4-928-635-01	SCREW, +BV (2.6X8) TAPPING	
4	4-922-531-01	KNOB (A TYPE), LOV	
5	4-922-921-01	BUTTON (POWER)	
6	4-933-135-01	RING (DIA. 58A), ORNAMENTAL (EXCEPT US, Canadian)	
7	4-942-763-01	PAENL, LOADING (MADE IN JAPAN 295/491)	
7	4-942-763-11	PAENL, LOADING (MADE IN FRANCE 295:AEP/491:UK)	
7	4-942-763-21	PAENL, LOADING (MADE IN JAPAN 195)	
7	4-942-763-31	PAENL, LOADING (MADE IN FRANCE 195)	
8	3-704-366-01	SCREW (CASE) (M3X8)	
9	4-929-035-31	CASE (MADE IN JAPAN 195/295/491)	
9	4-929-035-41	CASE (MADE IN FRANCE 195/295/491)	
10	△ 1-574-390-31	CORD, POWER (491:UK)	
10	△ 1-574-653-21	CORD, POWER (E)	
10	△ 1-558-945-21	CORD, POWER (POLAR, SPT-1) (US, Canadian)	
10	△ 1-574-127-31	CORD, POWER (MADE IN FRANCE 195/295:AEP)	
10	△ 1-574-358-31	CORD, POWER (WITH CONNECTOR) (195/295:Australian)	
10	△ 1-575-651-21	CORD, POWER (MADE IN JAPAN AEP, Saudi Arabia)	
11	△ 1-569-007-11	ADAPTOR, CONVERSION 2P (195/295:E)	
11	△ 1-569-008-11	ADAPTOR, CONVERSION 2P (195:Saudi Arabia)	
12	* 3-703-244-00	BUSHING (2104), CORD (EXCEPT E, US, Canadian)	
12	* 3-703-571-12	BUSHING (S) (4516), CORD (E, US, Canadian)	
13	4-886-821-11	SCREW, S TIGHT, +PTTWH 3X6	
14	4-902-345-01	HEAT SINK	

Ref. No.	Part No.	Description	Remark
15	* 4-942-769-21	PANEL, BACK (MADE IN JAPAN 295:AEP)	
15	* 4-942-770-21	PANEL, BACK (MADE IN JAPAN 195:AEP)	
15	* 4-942-770-41	PANEL, BACK (195:Australian)	
15	* 4-942-769-41	PANEL, BACK (295:Australian)	
15	* 4-942-770-31	PANEL, BACK (195:E, Saudi Arabia)	
15	* 4-942-769-11	PANEL, BACK (295:Canadian)	
15	* 4-942-770-11	PANEL, BACK (195:Canadian)	
15	* 4-942-769-02	PANEL, BACK (491:US)	
15	* 4-942-770-01	PANEL, BACK (195:US)	
15	* 4-942-769-31	PANEL, BACK (295:E)	
15	* 4-942-769-51	PANEL, BACK (MADE IN FRANCE 195, 295:AEP/491:UK)	
16	* A-4617-692-A	MAIN BOARD, COMPLETE (MADE IN FRANCE)	
16	* A-4617-706-A	MAIN BOARD, COMPLETE (MADE IN JAPAN AEP, US, Canadian, Australian)	
16	* A-4617-708-A	MAIN BOARD, COMPLETE (MADE IN JAPAN E, Saudi Arabia)	
17	* 3-349-025-41	HOLDER, PC BOARD	
18	* 4-924-098-01	HOLDER, PC BOARD	
19	* A-4617-713-A	DISPLAY BOARD, COMPLETE (MADE IN FRANCE)	
19	* A-4617-705-A	DISPLAY BOARD, COMPLETE (MADE IN JAPAN 195/295/491)	
20	1-575-002-11	WIRE, FLAT TYPE (22 CORE)	
21	* 1-637-906-11	POWER SW BOARD (MADE IN JAPAN)	
21	* 1-637-906-21	POWER SW BOARD (MADE IN FRANCE)	
22	X-3304-938-2	FOOT ASSY (EXCEPT US, Canadian)	
22	X-4885-950-2	FOOT ASSY (US, Canadian)	
23	4-923-836-11	CUSHION	
24	* 1-637-908-11	VOL BOARD (MADE IN JAPAN)	
24	* 1-637-908-21	VOL BOARD (MADE IN FRANCE)	
CN401	1-535-883-11	JUMPER, FILM (WITH TERMINAL)	
FLD401	1-519-611-11	INDICATOR TUBE, FLUORESCENT	
T901 △	1-449-923-11	TRANSFORMER, POWER (E, Saudi Arabia)	
T901 △	1-449-921-11	TRANSFORMER, POWER (US, Canadian)	
T901 △	1-449-925-11	TRANSFORMER, POWER (MADE IN FRANCE AEP, UK)	
T901 △	1-449-922-11	TRANSFORMER, POWER (MADE IN JAPAN AEP, Australian)	

(2) MD SECTION (CDM14-5BD1)

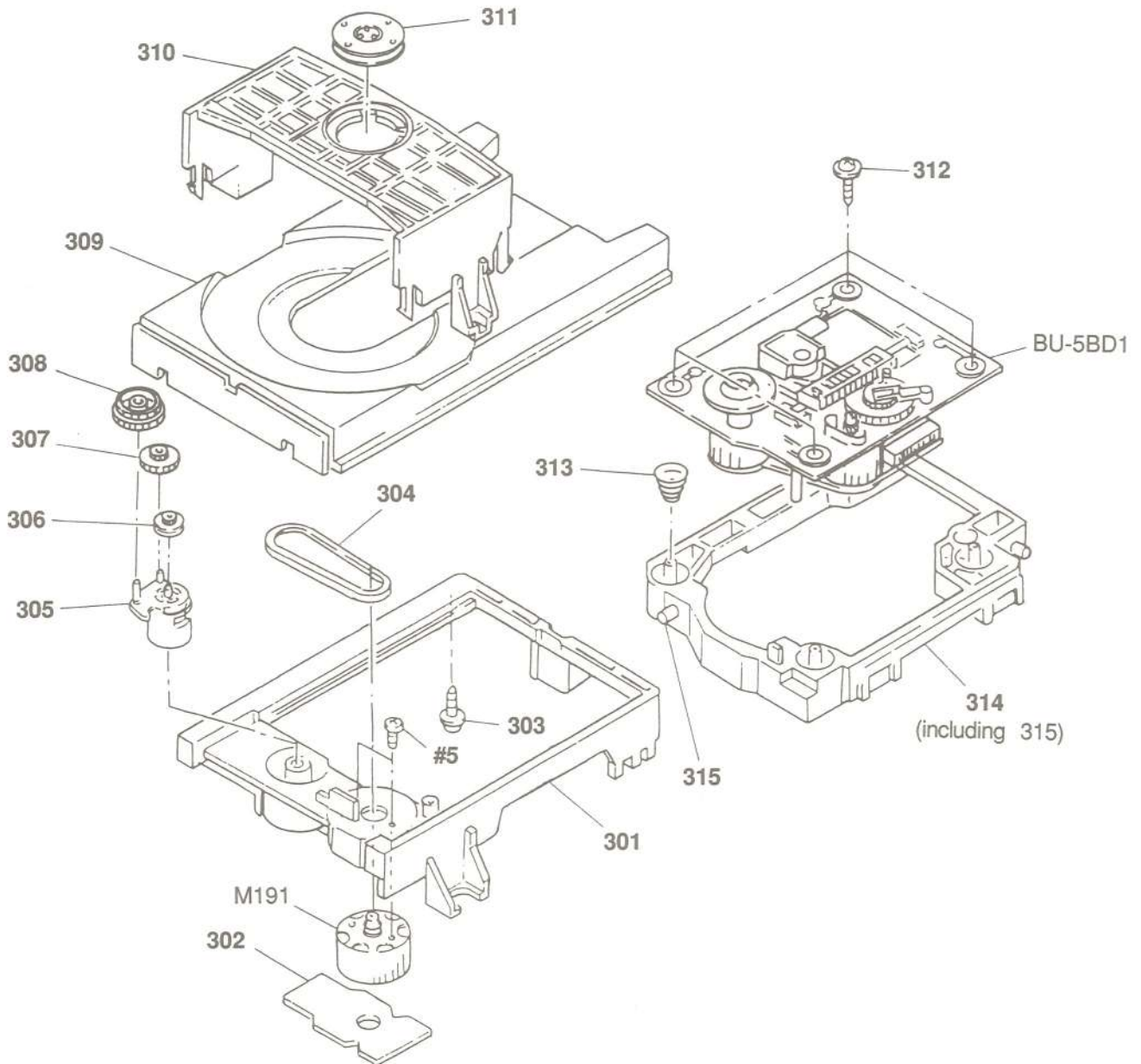

Ref.No.	Part No.	Description	Remark
301	4-933-111-01	CHASSIS (MD)	
302	* 1-632-202-11	LOADING BOARD	
303	* 4-917-583-21	BRACKET, YOKE	
304	4-927-649-01	BELT	
305	4-933-109-01	CAM	
306	4-927-651-01	PULLEY (S)	
307	4-927-628-01	GEAR (C)	
308	4-933-107-01	GEAR (PL)	

Ref.No.	Part No.	Description	Remark
309	4-933-112-01	TABLE, DISK	
310	4-933-110-01	HOLDER (MG)	
311	* 1-452-538-11	MAGNET	
312	4-933-134-01	SCREW (+PTPWH M2. 6X6)	
313	4-917-541-01	SPRING (B)	
314	4-933-129-01	HOLDER (BU) (INCLUDING 315)	
315	4-933-108-01	SHAFT (CAM)	
M191	A-4604-363-A	MOTOR (L) ASSY (LOADING)	

(3) PICK-UP BLOCK (BU-5BD1)

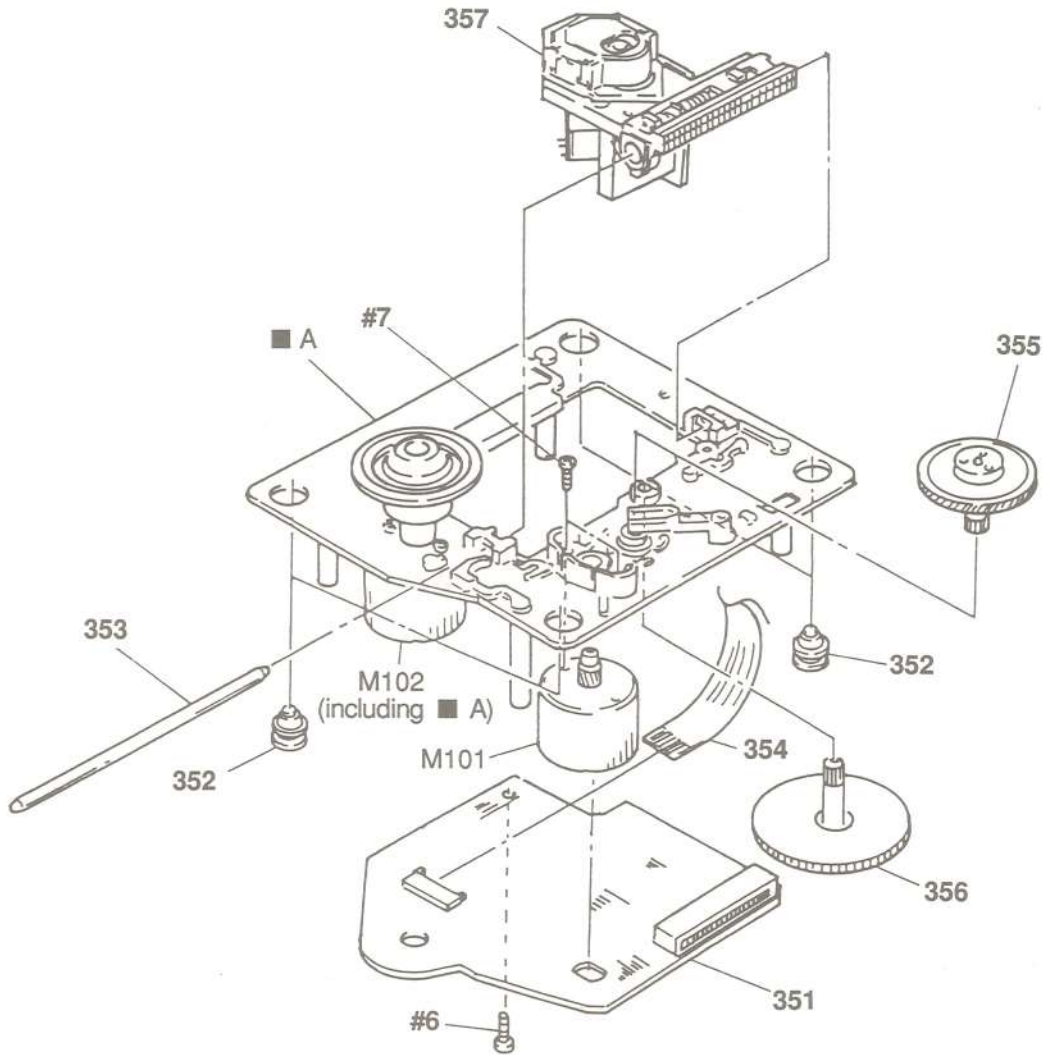

The components identified by mark \triangle or dotted line with mark \triangle are critical for safety.
Replace only with part number specified.

Les composants identifiés par une marque \triangle sont critiques pour la sécurité.
Ne les remplacer que par une pièce portant le numéro spécifié.

Ref. No.	Part No.	Description	Remark
351	A-4617-161-A	BD BOARD, COMPLETE	
352	4-933-126-01	INSULATOR (A)	
353	4-917-565-01	SHAFT, SLED	
354	1-575-001-11	WIRE, FLAT TYPE (12 CORE)	
355	4-917-567-01	GEAR (M)	
356	4-917-564-01	GEAR (P), FLATNESS	
357 \triangle	8-848-144-11	DEVICE, OPTICAL KSS-240A	
M101	X-4917-504-1	MOTOR ASSY (SLED)	
M102	X-4917-523-3	MOTOR ASSY (SPINDLE)	

SECTION 6

ELECTRICAL PARTS LIST

BD

NOTE:

The components identified by mark \triangle or dotted line with mark \triangle are critical for safety.
Replace only with part number specified.

Les composants identifiés par une marque \triangle sont critiques pour la sécurité.
Ne les remplacer que par une pièce portant le numéro spécifié.

When indicating parts by reference number, please include the board name.

- Due to standardization, replacements in the parts list may be different from the parts specified in the diagrams or the components used on the set.
- -XX, -X mean standardized parts, so they may have some difference from the original one.
- RESISTORS
All resistors are in ohms
METAL : Metal-film resistor
METAL OXIDE : Metal Oxide-film resistor
F : nonflammable
- Items marked "*" are not stocked since they are seldom required for routine service. Some delay should be anticipated when ordering these items.
- SEMICONDUCTORS
In each case, u : μ , for example :
uA...: μ A..., uPA...: μ PA...,
uPB...: μ PB..., uPC...: μ PC...,
uPD...: μ PD...
- CAPACITORS
uF : μ F
- COILS
uH : μ H
- Hardware(# mark) list is given in the last of this parts list.

Ref. No.	Part No.	Description	Remark	Ref. No.	Part No.	Description	Remark
	A-4617-161-A	BD BOARD, COMPLETE *****				< CONNECTOR >	
		< CAPACITOR >					
C101	1-163-038-00	CERAMIC CHIP 0.1uF	25V	CN101	1-568-796-11	SOCKET, CONNECTOR 22P	
C102	1-163-989-11	CERAMIC CHIP 0.033uF	10% 25V	CN102	1-568-795-11	SOCKET, CONNECTOR 12P	
C103	1-126-163-11	ELECT 4.7uF	20% 50V	CN103	* 1-564-721-11	PIN, CONNECTOR (SMALL TYPE) 5P	
C104	1-163-038-00	CERAMIC CHIP 0.1uF	25V			< DIODE >	
C105	1-126-154-11	ELECT 47uF	20% 6.3V	D101	8-719-105-72	DIODE RD4.7M-B1	
C106	1-126-154-11	ELECT 47uF	20% 6.3V			< IC >	
C107	1-126-154-11	ELECT 47uF	20% 6.3V	IC101	8-752-050-82	IC SC CXA1372Q	
C108	1-163-038-00	CERAMIC CHIP 0.1uF	25V	IC102	8-759-822-36	IC LA6532M	
C109	1-163-038-00	CERAMIC CHIP 0.1uF	25V	IC103	8-759-633-65	IC M54641L	
C110	1-163-989-11	CERAMIC CHIP 0.033uF	10% 25V			< JUMPER >	
C111	1-131-367-00	TANTALUM 22uF	10% 20V	J101	1-216-295-00	METAL CHIP 0 5% 1/10W	
C112	1-164-232-11	CERAMIC CHIP 0.01uF	50V	J102	1-216-295-00	METAL CHIP 0 5% 1/10W	
C113	1-164-232-11	CERAMIC CHIP 0.01uF	50V			< TRANSISTOR >	
C114	1-164-161-11	CERAMIC CHIP 0.0022uF	10% 100V	Q101	8-729-901-01	TRANSISTOR DTC144EK	
C115	1-164-161-11	CERAMIC CHIP 0.0022uF	10% 100V			< RESISTOR >	
C117	1-163-038-00	CERAMIC CHIP 0.1uF	25V	R101	1-216-097-00	METAL CHIP 100K 5% 1/10W	
C118	1-163-038-00	CERAMIC CHIP 0.1uF	25V	R102	1-216-095-00	METAL CHIP 82K 5% 1/10W	
C119	1-164-161-11	CERAMIC CHIP 0.0022uF	10% 100V	R103	1-216-091-00	METAL CHIP 56K 5% 1/10W	
C120	1-163-989-11	CERAMIC CHIP 0.033uF	10% 25V	R104	1-216-099-00	METAL CHIP 120K 5% 1/10W	
C151	1-163-019-00	CERAMIC CHIP 0.0068uF	10% 50V	R105	1-216-069-00	METAL CHIP 6.8K 5% 1/10W	
C152	1-163-038-00	CERAMIC CHIP 0.1uF	25V	R106	1-216-061-00	METAL CHIP 3.3K 5% 1/10W	
C153	1-163-006-11	CERAMIC CHIP 560PF	10% 50V	R107	1-216-114-00	METAL GLAZE 510K 5% 1/10W	
C154	1-164-161-11	CERAMIC CHIP 0.0022uF	10% 100V	R108	1-216-105-00	METAL CHIP 220K 5% 1/10W	
C155	1-163-023-00	CERAMIC CHIP 0.015uF	5% 50V	R109	1-216-061-00	METAL CHIP 3.3K 5% 1/10W	
C171	1-163-038-00	CERAMIC CHIP 0.1uF	25V	R110	1-216-049-00	METAL CHIP 1K 5% 1/10W	
C172	1-163-038-00	CERAMIC CHIP 0.1uF	25V				
C173	1-163-038-00	CERAMIC CHIP 0.1uF	25V				
C174	1-163-038-00	CERAMIC CHIP 0.1uF	25V				

Ref. No.	Part No.	Description	Remark		
R111	1-216-049-00	METAL CHIP	1K	5%	1/10W
R112	1-216-083-00	METAL CHIP	27K	5%	1/10W
R113	1-216-071-00	METAL CHIP	8.2K	5%	1/10W
R114	1-216-105-00	METAL CHIP	220K	5%	1/10W
R152	1-216-073-00	METAL CHIP	10K	5%	1/10W
R153	1-216-085-00	METAL CHIP	33K	5%	1/10W
R154	1-216-085-00	METAL CHIP	33K	5%	1/10W
R155	1-216-093-00	METAL CHIP	68K	5%	1/10W
R156	1-216-081-00	METAL CHIP	22K	5%	1/10W
R157	1-216-079-00	METAL CHIP	18K	5%	1/10W
R158	1-216-079-00	METAL CHIP	18K	5%	1/10W
R159	1-216-079-00	METAL CHIP	18K	5%	1/10W
R160	1-216-049-00	METAL CHIP	1K	5%	1/10W
R171	1-216-001-00	METAL CHIP	10	5%	1/10W
R172	1-216-001-00	METAL CHIP	10	5%	1/10W
R173	1-216-001-00	METAL CHIP	10	5%	1/10W
R174	1-216-001-00	METAL CHIP	10	5%	1/10W

< VARIABLE RESISTOR >

RV101	1-238-016-11	RES, ADJ, CARBON 10K (TRACKING GAIN)
RV102	1-238-016-11	RES, ADJ, CARBON 10K (FOCUS GAIN)

< SWITCH >

S101	1-572-085-11	SWITCH, LEAF (LIMIT IN)
------	--------------	-------------------------

- * A-4617-705-A DISPLAY BOARD, COMPLETE (MADE IN JAPAN)
- * A-4617-713-A DISPLAY BOARD, COMPLETE (MADE IN FRANCE)

4-944-482-11	SPACER (75X7)
--------------	---------------

< CAPACITOR >

C401	1-163-038-00	CERAMIC CHIP	0.1uF	25V
C402	1-124-261-00	ELECT	10uF	20% 50V
C403	1-163-038-00	CERAMIC CHIP	0.1uF	25V
C404	1-124-261-00	ELECT	10uF	20% 50V

< CONNECTOR >

CN401	1-535-883-11	JUMPER, FILM (WITH TERMINAL)
-------	--------------	------------------------------

< INDICATOR FLUORESCENT >

FLD401	1-519-611-11	INDICATOR TUBE, FLUORESCENT
--------	--------------	-----------------------------

Ref. No.	Part No.	Description	Remark		
< IC >					

IC401	8-752-817-41	IC CXP50112-097Q
IC402	8-749-920-83	IC GP1U52XB

< RESISTOR >

R402	1-216-065-00	METAL CHIP	4.7K	5%	1/10W
R403	1-216-065-00	METAL CHIP	4.7K	5%	1/10W
R404	1-216-079-00	METAL CHIP	18K	5%	1/10W
R405	1-216-069-00	METAL CHIP	6.8K	5%	1/10W
R406	1-216-063-00	METAL CHIP	3.9K	5%	1/10W

R407	1-216-059-00	METAL CHIP	2.7K	5%	1/10W
R408	1-216-079-00	METAL CHIP	18K	5%	1/10W
R409	1-216-069-00	METAL CHIP	6.8K	5%	1/10W
R410	1-216-063-00	METAL CHIP	3.9K	5%	1/10W
R411	1-216-059-00	METAL CHIP	2.7K	5%	1/10W

R412	1-216-079-00	METAL CHIP	18K	5%	1/10W
R413	1-216-069-00	METAL CHIP	6.8K	5%	1/10W
R414	1-216-063-00	METAL CHIP	3.9K	5%	1/10W
R415	1-216-059-00	METAL CHIP	2.7K	5%	1/10W
R416	1-216-079-00	METAL CHIP	18K	5%	1/10W

R417	1-216-069-00	METAL CHIP	6.8K	5%	1/10W
R418	1-216-063-00	METAL CHIP	3.9K	5%	1/10W
R419	1-216-059-00	METAL CHIP	2.7K	5%	1/10W
R420	1-216-079-00	METAL CHIP	18K	5%	1/10W
R421	1-216-069-00	METAL CHIP	6.8K	5%	1/10W

R422	1-216-063-00	METAL CHIP	3.9K	5%	1/10W
R423	1-216-059-00	METAL CHIP	2.7K	5%	1/10W
R424	1-216-079-00	METAL CHIP	18K	5%	1/10W
R425	1-216-069-00	METAL CHIP	6.8K	5%	1/10W
R426	1-216-063-00	METAL CHIP	3.9K	5%	1/10W

R427	1-216-059-00	METAL CHIP	2.7K	5%	1/10W
R428	1-216-073-00	METAL CHIP	10K	5%	1/10W
R429	1-216-073-00	METAL CHIP	10K	5%	1/10W
R430	1-216-073-00	METAL CHIP	10K	5%	1/10W
R431	1-216-073-00	METAL CHIP	10K	5%	1/10W

R432	1-216-073-00	METAL CHIP	10K	5%	1/10W
R433	1-216-073-00	METAL CHIP	10K	5%	1/10W
R434	1-216-079-00	METAL CHIP	18K	5%	1/10W
R435	1-216-079-00	METAL CHIP	18K	5%	1/10W

< SWITCH > (MADE IN JAPAN)

S401	1-554-303-81	SWITCH, KEY BOARD (1)
S402	1-554-303-81	SWITCH, KEY BOARD (2)
S403	1-554-303-81	SWITCH, KEY BOARD (3)
S404	1-554-303-81	SWITCH, KEY BOARD (4)
S405	1-554-303-81	SWITCH, KEY BOARD (5)

When indicating parts by reference number, please include the board name.

DISP LOADING MAIN

Ref. No.	Part No.	Description	Remark
S406	1-554-303-81	SWITCH, KEY BOARD (6)	
S407	1-554-303-81	SWITCH, KEY BOARD (7)	
S408	1-554-303-81	SWITCH, KEY BOARD (8)	
S409	1-554-303-81	SWITCH, KEY BOARD (9)	
S410	1-554-303-81	SWITCH, KEY BOARD (10)	
S411	1-554-303-81	SWITCH, KEY BOARD (11)	
S412	1-554-303-81	SWITCH, KEY BOARD (12)	
S413	1-554-303-81	SWITCH, KEY BOARD (>12)	
S414	1-554-303-81	SWITCH, KEY BOARD (MUSIC SCAN)	
S415	1-554-303-81	SWITCH, KEY BOARD (PEAK SEARCH)	
S416	1-554-303-81	SWITCH, KEY BOARD (CONTINUE)	
S417	1-554-303-81	SWITCH, KEY BOARD (SHUFFLE)	
S419	1-554-303-81	SWITCH, KEY BOARD (EDIT/TIME FADE)	
S420	1-554-303-81	SWITCH, KEY BOARD (▶▶▶.▶▶▶)	
S421	1-554-303-81	SWITCH, KEY BOARD (◀◀◀.◀◀◀)	
S422	1-554-303-81	SWITCH, KEY BOARD (■)	
S423	1-554-303-81	SWITCH, KEY BOARD (■■)	
S424	1-554-303-81	SWITCH, KEY BOARD (▶)	
S425	1-554-303-81	SWITCH, KEY BOARD (OPEN/CLOSE ▲)	
S426	1-554-303-81	SWITCH, KEY BOARD (CHECK)	
S427	1-554-303-81	SWITCH, KEY BOARD (CLEAR)	
S428	1-554-303-81	SWITCH, KEY BOARD (TIMER)	
S429	1-554-303-81	SWITCH, KEY BOARD (REPEAT)	
S430	1-554-303-81	SWITCH, KEY BOARD (FADER)	
S718	1-554-303-81	SWITCH, KEY BOARD (PROGRAM)	

< SWITCH > (MADE IN FRANCE)

S401	1-554-303-52	SWITCH, KEY BOARD (1)	
S402	1-554-303-52	SWITCH, KEY BOARD (2)	
S403	1-554-303-52	SWITCH, KEY BOARD (3)	
S404	1-554-303-52	SWITCH, KEY BOARD (4)	
S405	1-554-303-52	SWITCH, KEY BOARD (5)	
S406	1-554-303-52	SWITCH, KEY BOARD (6)	
S407	1-554-303-52	SWITCH, KEY BOARD (7)	
S408	1-554-303-52	SWITCH, KEY BOARD (8)	
S409	1-554-303-52	SWITCH, KEY BOARD (9)	
S410	1-554-303-52	SWITCH, KEY BOARD (10)	
S411	1-554-303-52	SWITCH, KEY BOARD (11)	
S412	1-554-303-52	SWITCH, KEY BOARD (12)	
S413	1-554-303-52	SWITCH, KEY BOARD (>12)	
S414	1-554-303-52	SWITCH, KEY BOARD (MUSIC SCAN)	
S415	1-554-303-52	SWITCH, KEY BOARD (PEAK SEARCH)	
S416	1-554-303-52	SWITCH, KEY BOARD (CONTINUE)	
S417	1-554-303-52	SWITCH, KEY BOARD (SHUFFLE)	
S419	1-554-303-52	SWITCH, KEY BOARD (EDIT/TIME FADE)	
S420	1-554-303-52	SWITCH, KEY BOARD (▶▶▶.▶▶▶)	
S421	1-554-303-52	SWITCH, KEY BOARD (◀◀◀.◀◀◀)	

Ref. No.	Part No.	Description	Remark
S422	1-554-303-52	SWITCH, KEY BOARD (■)	
S423	1-554-303-52	SWITCH, KEY BOARD (■■)	
S424	1-554-303-52	SWITCH, KEY BOARD (▶)	
S425	1-554-303-52	SWITCH, KEY BOARD (OPEN/CLOSE ▲)	
S426	1-554-303-52	SWITCH, KEY BOARD (CHECK)	
S427	1-554-303-52	SWITCH, KEY BOARD (CLEAR)	
S428	1-554-303-52	SWITCH, KEY BOARD (TIMER)	
S429	1-554-303-52	SWITCH, KEY BOARD (REPEAT)	
S430	1-554-303-52	SWITCH, KEY BOARD (FADER)	
S718	1-554-303-52	SWITCH, KEY BOARD (PROGRAM)	

< CRYSTAL >

X401 1-577-358-21 VIBRATOR, CERAMIC (4MHz)

* 1-632-202-11 LOADING BOARD

< CONNECTOR >

CN301 * 1-564-707-11 PIN, CONNECTOR (SMALL TYPE) 5P

< SWITCH >

S191 1-572-086-11 SWITCH, LEAF (LOAD OUT)
S192 1-572-086-11 SWITCH, LEAF (LOAD IN)

* A-4617-692-A MAIN BOARD, COMPLETE
(MADE IN FRANCE AEP, UK)
* A-4617-706-A MAIN BOARD, COMPLETE (MADE IN JAPAN:
AEP, US, Canadian, Australian)
* A-4617-708-A MAIN BOARD, COMPLETE (MADE IN JAPAN:
E, Saudi Arabia)

4-902-345-01 HEAT SINK
7-682-547-09 SCREW +B 3X6

< CAPACITOR >

C201	1-124-572-11	ELECT	100uF	20%	63V
C202	1-123-875-11	ELECT	10uF	20%	50V
C203	1-124-360-00	ELECT	1000uF	20%	16V
C204	1-124-898-11	ELECT	4700uF	20%	16V
C205	1-124-927-11	ELECT	4.7uF	20%	100V
C206	1-123-875-11	ELECT	10uF	20%	50V
C207	1-123-875-11	ELECT	10uF	20%	50V
C208	1-124-472-11	ELECT	470uF	20%	10V
C209	1-124-472-11	ELECT	470uF	20%	10V
C210	1-124-120-11	ELECT	220uF	20%	25V

When indicating parts by reference number, please include the board name.

Ref. No.	Part No.	Description			Remark
C211	1-124-472-11	ELECT	470uF	20%	10V
C212	1-124-472-11	ELECT	470uF	20%	10V
C221	1-164-159-11	CERAMIC	0.1uF		50V
C301	1-124-477-11	ELECT	47uF	20%	25V
C302	1-124-791-11	ELECT	1.0uF	20%	100V
C311	1-106-383-00	MYLAR	0.047uF	5%	200V
C312	1-161-374-11	CERAMIC	0.0015uF	20%	50V
C313	1-161-494-00	CERAMIC	0.022uF		25V
C314	1-162-306-11	CERAMIC	0.01uF	20%	16V
C315	1-124-902-00	ELECT	0.47uF	20%	50V
C316	1-161-494-00	CERAMIC	0.022uF		25V
C317	1-164-159-11	CERAMIC	0.1uF		50V
C321	1-161-494-00	CERAMIC	0.022uF		25V
C331	1-162-208-31	CERAMIC	24PF	5%	50V
C332	1-106-220-00	MYLAR	0.1uF	5%	100V
C333	1-161-494-00	CERAMIC	0.022uF		25V
C335	1-162-205-31	CERAMIC	18PF	5%	50V
C341	1-161-494-00	CERAMIC	0.022uF		25V
C342	1-124-477-11	ELECT	47uF	20%	25V
C343	1-161-494-00	CERAMIC	0.022uF		25V
C344	1-161-494-00	CERAMIC	0.022uF		25V
C345	1-124-477-11	ELECT	47uF	20%	25V
C346	1-164-159-11	CERAMIC	0.1uF		50V
C347	1-124-477-11	ELECT	47uF	20%	25V
C348	1-164-159-11	CERAMIC	0.1uF		50V
C349	1-161-494-00	CERAMIC	0.022uF		25V
C350	1-124-477-11	ELECT	47uF	20%	25V
C351	1-161-494-00	CERAMIC	0.022uF		25V
C352	1-124-477-11	ELECT	47uF	20%	25V
C353	1-162-199-31	CERAMIC	10PF	5%	50V
C354	1-162-199-31	CERAMIC	10PF	5%	50V
C355	1-161-494-00	CERAMIC	0.022uF		25V
C356	1-124-477-11	ELECT	47uF	20%	25V
C357	1-124-472-11	ELECT	470uF	20%	10V
C361	1-162-285-31	CERAMIC	180PF	10%	50V
C362	1-162-285-31	CERAMIC	180PF	10%	50V
C363	1-162-283-31	CERAMIC	120PF	10%	50V
C364	1-162-283-31	CERAMIC	120PF	10%	50V
C365	1-162-283-31	CERAMIC	120PF	10%	50V
C366	1-162-283-31	CERAMIC	120PF	10%	50V
C367	1-161-494-00	CERAMIC	0.022uF		25V
C368	1-161-494-00	CERAMIC	0.022uF		25V
C371	1-106-359-00	MYLAR	4700PF	5%	200V
C372	1-106-359-00	MYLAR	4700PF	5%	200V
C373	1-106-345-00	MYLAR	0.0012uF	5%	100V
C374	1-106-345-00	MYLAR	0.0012uF	5%	100V
C375	1-161-494-00	CERAMIC	0.022uF		25V
C376	1-161-494-00	CERAMIC	0.022uF		25V
C377	1-124-477-11	ELECT	47uF	20%	25V

Ref. No.	Part No.	Description			Remark
C378	1-124-477-11	ELECT	47uF	20%	25V
C379	1-106-349-00	MYLAR	0.0018uF	5%	100V
C380	1-106-349-00	MYLAR	0.0018uF	5%	100V
C392	1-164-159-11	CERAMIC	0.1uF		50V
C394	1-164-159-11	CERAMIC	0.1uF		50V
< CONNECTOR >					
CN201	* 1-580-230-11	PIN, CONNECTOR (PC BOARD)			3P
CN301	* 1-568-843-11	SOCKET, CONNECTOR			28P
CN302	* 1-568-822-11	SOCKET, CONNECTOR			22P
CN381	* 1-564-708-11	PIN, CONNECTOR (SMALL TYPE)			6P
< DIODE >					
D201	8-719-200-82	DIODE 11ES2			
D202	8-719-109-96	DIODE RD6.8ES-T1B			
D203	8-719-200-82	DIODE 11ES2			
D204	8-719-200-82	DIODE 11ES2			
D205	8-719-200-82	DIODE 11ES2			
D206	8-719-200-82	DIODE 11ES2			
D207	8-719-114-49	DIODE RD7.5JS-T1B2			
D208	8-719-109-89	DIODE RD5.6ES-B2			
D209	8-719-107-94	DIODE 1SS202-1 (MADE IN FRANCE)			
D209	8-719-987-63	DIODE 1N4148M (MADE IN JAPAN)			
D341	8-719-210-21	DIODE 11EQS04			
D351	8-719-107-94	DIODE 1SS202-1 (MADE IN FRANCE)			
D351	8-719-987-63	DIODE 1N4148M (MADE IN JAPAN)			
< IC >					
IC201	8-759-633-42	IC M5293L			
IC202	8-759-630-21	IC M5290P-16			
IC203	8-759-945-58	IC RC4558P			
IC301	8-752-337-26	IC CXD2500AQ			
IC302	8-752-337-09	IC CXD2554P			
IC303	8-759-917-18	IC SN74HCU04AN			
IC305	8-752-334-87	IC CXD2552Q			
IC306	8-759-990-82	IC TL082CP			
IC307	8-759-945-58	IC RC4558P			
< JACK >					
J381	1-569-442-11	JACK, PIN 2P (LINE OUT)			
< COIL >					
L331	1-408-403-00	INDUCTOR 3.3uH			
< IC LINK >					
PS201	△ 1-532-685-00	LINK, IC (ICP-N20)			
PS202	△ 1-532-637-00	LINK, IC 1.0A (ICP-N25)			

The components identified by mark △ or dotted line with mark △ are critical for safety.
Replace only with part number specified.

Les composants identifiés par une marque △ sont critiques pour la sécurité.
Ne les remplacer que par une pièce portant le numéro spécifié.

When indicating parts by reference number, please include the board name.

MAIN

POWER SW

Ref. No.	Part No.	Description	Remark
< TRANSISTOR >			
Q201	8-729-119-76	TRANSISTOR 2SA1175-HFE	
Q202	8-729-140-96	TRANSISTOR 2SD774-34	
Q203	8-729-111-67	TRANSISTOR 2SB1094-L	
Q204	8-729-900-65	TRANSISTOR DTA144ES	
Q205	8-729-900-89	TRANSISTOR DTC144ES	
Q206	8-729-900-89	TRANSISTOR DTC144ES	
Q207	8-729-230-45	TRANSISTOR 2SC2458-YGR	
Q208	8-729-821-73	TRANSISTOR 2SB1274SA-RS	
Q209	8-729-281-52	TRANSISTOR 2SC1815Y-Y	
Q343	8-729-900-65	TRANSISTOR DTA144ES	
Q344	8-729-900-89	TRANSISTOR DTC144ES	
Q371	8-729-141-30	TRANSISTOR 2SC3623A-LK	
Q372	8-729-141-30	TRANSISTOR 2SC3623A-LK	
Q373	8-729-141-30	TRANSISTOR 2SC3623A-LK	
Q374	8-729-141-30	TRANSISTOR 2SC3623A-LK	
< RESISTOR >			
R201	1-249-435-11	CARBON 33K	5% 1/4W
R202	1-249-438-11	CARBON 56K	5% 1/4W
R203	1-249-429-11	CARBON 10K	5% 1/4W
R204	1-249-425-11	CARBON 4.7K	5% 1/4W
R205	1-249-425-11	CARBON 4.7K	5% 1/4W
R206	1-249-417-11	CARBON 1K	5% 1/4W
R207	1-249-417-11	CARBON 1K	5% 1/4W
R208	1-249-423-11	CARBON 3.3K	5% 1/4W
R209	1-249-413-11	CARBON 470	5% 1/4W
R210	1-249-429-11	CARBON 10K	5% 1/4W
R211	1-249-410-11	CARBON 270	5% 1/4W
R214	1-249-417-11	CARBON 1K	5% 1/4W
R301	1-249-421-11	CARBON 2.2K	5% 1/4W
R302	1-249-421-11	CARBON 2.2K	5% 1/4W
R303	1-249-421-11	CARBON 2.2K	5% 1/4W
R304	1-249-421-11	CARBON 2.2K	5% 1/4W
R311	1-249-423-11	CARBON 3.3K	5% 1/4W
R312	1-249-429-11	CARBON 10K	5% 1/4W
R313	1-249-423-11	CARBON 3.3K	5% 1/4W
R314	1-249-429-11	CARBON 10K	5% 1/4W
R315	1-249-417-11	CARBON 1K	5% 1/4W
R316	1-249-417-11	CARBON 1K	5% 1/4W
R317	1-249-420-11	CARBON 1.8K	5% 1/4W
R318	1-249-441-11	CARBON 100K	5% 1/4W
R321	1-249-417-11	CARBON 1K	5% 1/4W
R322	1-249-417-11	CARBON 1K	5% 1/4W
R323	1-249-417-11	CARBON 1K	5% 1/4W
R324	1-249-418-11	CARBON 1.2K	5% 1/4W
R331	1-249-409-11	CARBON 220	5% 1/4W
R332	1-247-887-00	CARBON 220K	5% 1/4W

Ref. No.	Part No.	Description	Remark
R333	1-249-417-11	CARBON 1K	5% 1/4W
R334	1-249-409-11	CARBON 220	5% 1/4W
R341	1-249-393-11	CARBON 10	5% 1/4W
R342	1-249-417-11	CARBON 1K	5% 1/4W
R347	1-249-441-11	CARBON 100K	5% 1/4W
R348	1-249-429-11	CARBON 10K	5% 1/4W
R351	1-249-429-11	CARBON 10K	5% 1/4W
R352	1-249-429-11	CARBON 10K	5% 1/4W
R353	1-249-429-11	CARBON 10K	5% 1/4W
R354	1-249-429-11	CARBON 10K	5% 1/4W
R355	1-247-848-11	CARBON 5.1K	5% 1/4W
R356	1-249-405-11	CARBON 100	5% 1/4W
R361	1-247-838-00	CARBON 2K	5% 1/4W
R362	1-247-838-00	CARBON 2K	5% 1/4W
R363	1-247-838-00	CARBON 2K	5% 1/4W
R364	1-247-838-00	CARBON 2K	5% 1/4W
R365	1-249-432-11	CARBON 18K	5% 1/4W
R366	1-249-432-11	CARBON 18K	5% 1/4W
R367	1-249-432-11	CARBON 18K	5% 1/4W
R368	1-249-432-11	CARBON 18K	5% 1/4W
R369	1-249-419-11	CARBON 1.5K	5% 1/4W
R370	1-249-419-11	CARBON 1.5K	5% 1/4W
R371	1-249-419-11	CARBON 1.5K	5% 1/4W
R372	1-249-419-11	CARBON 1.5K	5% 1/4W
R373	1-247-887-00	CARBON 220K	5% 1/4W
R374	1-247-887-00	CARBON 220K	5% 1/4W
R375	1-249-409-11	CARBON 220	5% 1/4W
R376	1-249-409-11	CARBON 220	5% 1/4W
R377	1-249-409-11	CARBON 220	5% 1/4W
R378	1-249-409-11	CARBON 220	5% 1/4W
R379	1-249-425-11	CARBON 4.7K	5% 1/4W
R380	1-249-425-11	CARBON 4.7K	5% 1/4W
R381	1-249-425-11	CARBON 4.7K	5% 1/4W
R382	1-249-425-11	CARBON 4.7K	5% 1/4W
R383	1-249-414-11	CARBON 560	5% 1/4W
R384	1-249-414-11	CARBON 560	5% 1/4W

< SWITCH >

S201 Δ 1-571-722-11 SWITCH, VOLTAGE SELECTION
(E. Saudi Arabia)

< CRYSTAL >

X351 1-579-161-11 VIBRATOR, CRYSTAL (45MHz)

* 1-637-906-11 POWER SW BOARD (MADE IN JAPAN)

* 1-637-906-21 POWER SW BOARD (MADE IN FRANCE)

The components identified by mark Δ or dotted line with mark Δ are critical for safety.
Replace only with part number specified.

Les composants identifiés par une marque Δ sont critiques pour la sécurité.
Ne les remplacer que par une pièce portant le numéro spécifié.

When indicating parts by reference number, please include the board name.

POWER SW

VOL

Ref. No.	Part No.	Description	Remark
		< CONNECTOR >	
CN491	* 1-568-953-11	PIN, CONNECTOR 4P	
		< SWITCH >	
S491	1-554-118-00	SWITCH, PUSH (1 KEY) (POWER)	

	* 1-637-908-11	VOL BOARD (MADE IN JAPAN)	
	* 1-637-908-21	VOL BOARD (MADE IN FRANCE)	

		< CAPACITOR >	
C510	1-124-584-00	ELECT 100uF 20% 10V	
C511	1-163-133-00	CERAMIC CHIP 470PF 5% 50V	
C520	1-124-584-00	ELECT 100uF 20% 10V	
C521	1-163-133-00	CERAMIC CHIP 470PF 5% 50V	
C530	1-163-038-00	CERAMIC CHIP 0.1uF 25V	
		< CONNECTOR >	
CN501	* 1-564-708-11	PIN, CONNECTOR (SMALL TYPE) 6P	
		< IC >	
IC501	8-759-981-89	IC RC4556S	
		< JACK >	
J501	1-568-519-41	JACK, LARGE TYPE (PHONES)	
		< COIL >	
L501	1-424-090-11	COIL, LINE FILTER	
L511	1-424-090-11	COIL, LINE FILTER	
L521	1-424-090-11	COIL, LINE FILTER	
		< RESISTOR >	
R510	1-216-049-00	METAL CHIP 1K 5% 1/10W	
R511	1-216-065-00	METAL CHIP 4.7K 5% 1/10W	
R512	1-216-067-00	METAL CHIP 5.6K 5% 1/10W	
R513	1-216-025-00	METAL CHIP 100 5% 1/10W	
R520	1-216-049-00	METAL CHIP 1K 5% 1/10W	
R521	1-216-065-00	METAL CHIP 4.7K 5% 1/10W	
R522	1-216-067-00	METAL CHIP 5.6K 5% 1/10W	
R523	1-216-025-00	METAL CHIP 100 5% 1/10W	
		< VARIABLE RESISTOR >	
RV501	1-241-386-11	RES, VAR. CARBON 20K/20K (LEVEL)	

Ref. No.	Part No.	Description	Remark
		MISCELLANEOUS	

10	△ 1-558-945-21	CORD, POWER (POLAR, SPT-1) (US, Canadian)	
10	△ 1-574-127-31	CORD, POWER (MADE IN FRANCE 195/295:AEP)	
10	△ 1-574-358-31	CORD, POWER (WITH CONNECTOR)	
10	△ 1-574-390-31	CORD, POWER (491:UK)	
10	△ 1-574-653-21	CORD, POWER (E)	
10	△ 1-575-651-21	CORD, POWER (MADE IN JAPAN)	
11	△ 1-569-007-11	ADAPTOR, CONVERSION 2P (195/295:E)	
11	△ 1-569-008-11	ADAPTOR, CONVERSION 2P	
20	1-575-002-11	WIRE, FLAT TYPE (22 CORE)	
21	* 1-637-906-11	POWER SW BOARD (MADE IN JAPAN)	
21	* 1-637-906-21	POWER SW BOARD (MADE IN FRANCE)	
24	* 1-637-908-11	VOL BOARD (MADE IN JAPAN)	
24	* 1-637-908-21	VOL BOARD (MADE IN FRANCE)	
311	* 1-452-538-11	MAGNET	
354	1-575-001-11	WIRE, FLAT TYPE (12 CORE)	
357	△ 8-848-144-11	DEVICE, OPTICAL KSS-240A	
CN401	1-535-883-11	JUMPER, FILM (WITH TERMINAL)	
FLD401	1-519-611-11	INDICATOR TUBE, FLUORESCENT	
M101	X-4917-504-1	MOTOR ASSY (SLED)	
M102	X-4917-523-3	MOTOR ASSY (SPINDLE)	
M191	A-4604-363-A	MOTOR (L) ASSY (LOADING)	
T901	△ 1-449-921-11	TRANSFORMER, POWER (US, Canadian)	
T901	△ 1-449-922-11	TRANSFORMER, POWER (MADE IN JAPAN AEP, Australian)	
T901	△ 1-449-923-11	TRANSFORMER, POWER (E, Saudi Arabia)	
T901	△ 1-449-925-11	TRANSFORMER, POWER (MADE IN FRANCE AEP, UK)	

The components identified by mark △ or dotted line with mark △ are critical for safety.
Replace only with part number specified.

Les composants identifiés par une marque △ sont critiques pour la sécurité.
Ne les remplacer que par une pièce portant le numéro spécifié.

When indicating parts by reference number, please include the board name.

Ref. No.	Part No.	Description	Remark
ACCESSORY & PACKING MATERIAL			
	1-465-635-11	COMMANDER, REMOTE (RM-D295) (MADE IN JAPAN 295/491)	
	1-465-635-21	COMMANDER, REMOTE (RM-D295) (MADE IN FRANCE 295/491)	
	1-558-271-11	CORD, CONNECTION	
	2-181-754-01	COVER (MLY), BATTERY (295/491)	
*	3-750-090-01	INSTRUCTION (MADE IN JAPAN 195:AEP, Canadian/295:Canadian)	
*	3-795-629-15	INSTRUCTION (MADE IN JAPAN 295:AEP)	
	3-752-961-11	MANUAL, INSTRUCTION (ENGLISH, F, E, P) (MADE IN JAPAN 295)	
	3-752-961-21	MANUAL, INSTRUCTION (ENGLISH) (MADE IN JAPAN 491:US)	
	3-752-961-41	MANUAL, INSTRUCTION (D, NL, S, I) (MADE IN JAPAN 295:AEP)	
	3-752-961-51	MANUAL, INSTRUCTION (ENGLISH, F, E, P) (MADE IN FRANCE 295:AEP/491:UK)	
	3-752-961-61	MANUAL, INSTRUCTION (D, NL, S, I) (MADE IN FRANCE 295:AEP)	
	3-752-962-11	MANUAL, INSTRUCTION (ENGLISH, F, E, P) (MADE IN JAPAN 195:AEP, E. Canadian, Saudi Arabia)	
	3-752-962-21	MANUAL, INSTRUCTION (ENGLISH) (MADE IN JAPAN 195:US)	
	3-752-962-51	MANUAL, INSTRUCTION (ENGLISH, F, E, P) (MADE IN FRANCE 195:AEP)	
	3-752-962-41	MANUAL, INSTRUCTION (D, NL, S, I) (MADE IN JAPAN 195:AEP)	
	3-752-962-61	MANUAL, INSTRUCTION (D, NL, S, I) (MADE IN FRANCE 195:AEP)	
*	4-925-389-01	CUSHION (MADE IN JAPAN 195/295/491)	
*	4-929-506-02	CUSHION (MADE IN FRANCE 195/295/491)	
*	4-941-548-01	LABEL, CLASS 1 (EXCEPT US, Canadian)	
*	4-939-718-41	INDIVIDUAL CARTON (MADE IN JAPAN 295)	
*	4-939-718-51	INDIVIDUAL CARTON (MADE IN JAPAN 491)	
*	4-939-718-61	INDIVIDUAL CARTON (MADE IN JAPAN 195)	
*	4-942-897-11	INDIVIDUAL CARTON (MADE IN FRANCE 295:AEP)	
*	4-942-897-21	INDIVIDUAL CARTON (MADE IN FRANCE 195:AEP)	
*	4-942-897-31	INDIVIDUAL CARTON (MADE IN FRANCE 491:UK)	

HARDWARE LIST

# 1	7-682-548-09	SCREW +BVTT 3X8 (S)
# 2	7-682-547-04	SCREW +BVTT 3X6 (S)
# 3	7-682-547-09	SCREW +B 3X6
# 4	7-685-646-79	SCREW +BVTP 3X8 TYPE2 N-S
# 5	7-621-775-10	SCREW +B 2.6X4
# 6	7-685-134-19	SCREW +BTP 2.6X8 TYPE2 N-S
# 7	7-621-255-15	SCREW +P 2X3

D: GERMAN F: FRENCH NL: DUTCH S: SWEDISH
E: SPANISH I: ITALIAN P: PORTUGUESE

Sony Corporation
Audio Group

- 34 -

English
91C1996-1
Printed in Japan
© 1991.3
Published by Customer Relations and Service Group