

SONY®

VIDEOCASSETTE RECORDER

BVU-950P

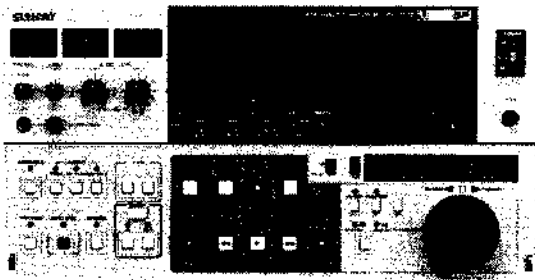

Professional **U-matic** **SP**
MAINTENANCE MANUAL
Volume 1 1st Edition (Revised 11)
Serial No.10001 and Higher

SAFETY CHECK-OUT

After correcting the original service problem, perform the following safety checks before releasing the set to the customer:

Check the metal trim, "metallized" knobs, screws, and all other exposed metal parts for AC leakage. Check leakage as described below.

LEAKAGE TEST

The AC leakage from any exposed metal part to earth ground and from all exposed metal parts to any exposed metal part having a return to chassis, must not exceed 3.5 mA. Leakage current can be measured by any one of three methods.

1. A commercial leakage tester, such as the Simpson 229 or RCA WT-540A. Follow the manufacturers' instructions to use these instruments.
2. A battery-operated AC milliammeter. The Data Precision 245 digital multimeter is suitable for this job.
3. Measuring the voltage drop across a resistor by means of a VOM or battery-operated AC voltmeter. The "limit" indication is 5.25 V, so analog meters must have an accurate low-voltage scale. The Simpson 250 and Sanwa SH-63Trd are examples of a passive VOM that is suitable. Nearly all battery operated digital multimeters that have a 20 V AC range are suitable. (See Fig. A)

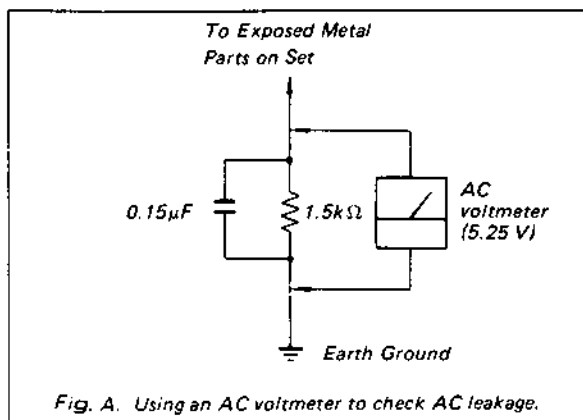

Fig. A. Using an AC voltmeter to check AC leakage.

このマニュアルに記載されている事柄の著作権は当社にあり、説明内容は機器購入者の使用を目的としています。従って、当社の許可なしに無断で複写したり、説明内容(操作、保守等)と異なる目的で本マニュアルを使用することを禁止します。

The material contained in this manual consists of information that is the property of Sony Corporation and is intended solely for use by the purchasers of the equipment described in this manual.

Sony Corporation expressly prohibits the duplication of any portion of this manual or the use thereof for any purpose other than the operation or maintenance of the equipment described in this manual without the express written permission of Sony Corporation.

Le matériel contenu dans ce manuel consiste en informations qui sont la propriété de Sony Corporation et sont destinées exclusivement à l'usage des acquéreurs de l'équipement décrit dans ce manuel.

Sony Corporation interdit formellement la copie de quelque partie que ce soit de ce manuel ou son emploi pour tout autre but que des opérations ou entretiens de l'équipement à moins d'une permission écrite de Sony Corporation.

Das in dieser Anleitung enthaltene Material besteht aus Informationen, die Eigentum der Sony Corporation sind, und ausschließlich zum Gebrauch durch den Käufer der in dieser Anleitung beschriebenen Ausrüstung bestimmt sind.

Die Sony Corporation untersagt ausdrücklich die Vervielfältigung jeglicher Teile dieser Anleitung oder den Gebrauch derselben für irgendeinen anderen Zweck als die Bedienung oder Wartung der in dieser Anleitung beschriebenen Ausrüstung ohne ausdrückliche schriftliche Erlaubnis der Sony Corporation.

TABLE OF CONTENTS

1. INSTALLATION

1-1.	Operational Environment	1-1
1-2.	Installation Space	1-1
1-3.	Input/Output Signal of the Connector	1-2
1-4.	Connection Connector	1-4
1-5.	Select Switch Setting	1-4
1-6.	Dial Menu Operation	1-6
1-6-1.	Button and Dial Settings	1-6
1-6-2.	Operation	1-6
1-6-3.	ITEM/DATA	1-9
1-6-4.	System Error	1-19
1-7.	Recording of Time Code Character and Title	1-21
1-7-1.	Setting the Time Code Character and the Title	1-21
1-7-2.	Insert the Characters on the Playback Picture	1-26
1-7-3.	Recording the Characters on the Tape ..	1-26
1-8.	Rack Mounting	1-27
1-9.	Function Control Panel Positioning	1-30
1-10.	Use of the Function Control Panel as a Remote Control Unit	1-30
1-11.	REMOTE 2 (24P) Connector	1-31
1-12.	Supplied Accessories	1-31
1-13.	Optional Accessories	1-32

2. TECHNICAL INFORMATION

2-1.	Specifications	2-1
2-2.	Location of Main Parts	2-3
2-2-1.	Location of the Mechanical Main Parts/Components	2-3
2-2-2.	Location of the Printed Circuit Boards ..	2-7
2-3.	Printed Circuit Boards	2-11
2-4.	Cassette Removal Procedure when Normal Ejection is not Possible	2-13
2-5.	The Tape Speed and Time in FF and REW Mode	2-14
2-6.	Timing Chart	2-16

3. PERIODIC CHECK AND MAINTENANCE

3-1.	System Control Operation Check	3-1
3-1-1.	Play Back, F.FWD, REW, SHUTTLE, JOG and Preroll Function Check	3-1
3-1-2.	Record Function Check	3-4
3-1-3.	Editing Function Check	3-6
3-2.	Hours Meter	3-8
3-3.	Cleaning Procedure	3-8
3-3-1.	Video Heads and Rotary Erase Heads	3-8
3-3-2.	Stationary Heads	3-8
3-3-3.	Tape Movement Areas	3-8

3-3-4.	Slip-rings and Brushes	3-8
3-4.	Head Degaussing	3-9
3-5.	Maintenance After Repairs	3-9
3-6.	Periodic Check and Maintenance Schedule	3-10

4. SERVICE INFORMATION

4-1.	Removal and Installation of the Cabinet	4-1
4-2.	Removal and Installation of the Function Control Panel	4-3
4-3.	Removal of the Cassette-up Compartment	4-3
4-4.	Service of the Special Printed Circuit Boards	4-4
4-4-1.	Service of the RP-30A Printed Circuit Board	4-4
4-4-2.	Replacement of Parts on the HN-80 Printed Circuit Board	4-4
4-4-3.	Removal of the PD-37 Printed Circuit Board	4-4
4-4-4.	Replacement of the MB-139 Printed Circuit Board	4-4
4-4-5.	Removal of the DR-53 and DR-59 Printed Circuit Boards	4-6
4-5.	Removal and Installation of the Power Block	4-6
4-6.	Extension Board	4-7
4-7.	Operation of the Unit Without Installing the Cassette-up Compartment and the Cassette Tape	4-7
4-8.	Spare Parts	4-7
4-9.	Fixture	4-8

5. REPLACEMENT OF MAJOR PARTS

5-1.	Replacement of the Upper Drum Assembly ..	5-1
5-2.	Replacement of the Drum Assembly	5-3
5-3.	Replacement of the Capstan Motor	5-3
5-4.	Replacement of the Reel Motor	5-4
5-5.	Replacement of the Head	5-5
5-5-1.	Replacement of the Audio/CTL Head ..	5-5
5-5-2.	Replacement of the Time Code Head ..	5-6
5-5-3.	Replacement of the Full Erase Head ..	5-7
5-6.	Replacement of the Tension Detector Block	5-7
5-6-1.	Replacement of the S Tension Detector	5-7
5-6-2.	Replacement of the T Tension Detector	5-8
5-6-3.	Replacement of the CDS of the S Tension Detector	5-9
5-6-4.	Replacement of the CDS of the T Tension Detector	5-9
5-7.	Replacement of the S Drawer Roller	5-10

5-8.	Replacement of the Threading Ring System	5-10
5-8-1.	Replacement of the Threading Ring	5-10
5-8-2.	Replacement/Adjustment of the TG-5 and TG-6	5-11
5-8-3.	Replacement/Adjustment of the Threading Roller	5-12
5-8-4.	Replacement of the Pinch Roller	5-12
5-9.	Replacement of the Threading Gear Box System	5-13
5-9-1.	Replacement of the Threading Gear Box	5-13
5-9-2.	Replacement of the Threading Motor	5-14
5-9-3.	Replacement of the Threading Belt	5-15
5-10.	Replacement of the Reel Table Rotation Detector Block	5-15
5-11.	Replacement of the Pinch Solenoid	5-16
5-12.	Items to be Adjusted After Main Parts Replacement	5-17

6. LINK AND DRIVE SYSTEM ALIGNMENT

Alignment Information	6-1
6-1. Reel Table System Adjustment	6-2
6-1-1. Cassette Holder Position Adjustment	6-2
6-1-2. Reel Table Height Adjustment	6-3
6-1-3. Reel Motor Shaft Slantness Adjustment	6-4
6-2. T Drawer Arm Block Adjustment	6-5
6-2-1. T Drawer Arm EJECT Position Adjustment	6-5
6-2-2. Unthread End Switch Position Adjustment	6-6
6-3. S Tension Detector Adjustment	6-7
6-3-1. S Tension Detector Rollor Azimuth/Zenith Adjustment	6-7
6-3-2. S Tension Detector Operating Point Adjustment	6-8
6-4. T Tension Detector Adjustment	6-9
6-4-1. T Tension Detector Guide Height Adjustment	6-9
6-4-2. T Tension Detector Guide Operating Position Adjustment	6-10
6-4-3. T Tension Detector Operating Point Adjustment	6-11
6-5. Threading System Adjustment	6-13
6-5-1. Threading Ring Rotation Adjustment	6-13
6-5-2. Gear Box Installing Position Adjustment	6-14
6-5-3. Pinch Rollor Self Alignment Adjustment	6-15
6-5-4. FR Detector Block Installing Position Adjustment	6-16
6-6. Pinch Lever Block Adjustment	6-17

6-6-1.	Pinch Lever Preset Adjustment	6-17
6-6-2.	Pinch Roller Preset Adjustment	6-18
6-6-3.	Pinch Solenoid Installing Position Adjustment	6-19
6-6-4.	Pinch Solenoid Block Position Adjustment	6-20
6-7.	T Tape Sensor Position Adjustment	6-21
6-8.	S Drawer Roller Block Limiter Adjustment	6-22
6-9.	Brake solenoid Position Adjustment	6-23
6-9-1.	T Brake Solenoid Position Adjustment ..	6-23
6-9-2.	S Brake Solenoid Position Adjustment ..	6-23
6-10.	Reel Table Rotation Detector Block Position Adjustment	6-24
6-11.	Cassette-up Compartment Adjustment	6-25
6-11-1.	Cassette-in Switch Position Adjustment ..	6-25
6-11-2.	Cassette-down Switch Position Adjustment	6-26
6-12.	Leaf Spring Position Adjustment	6-27
6-13.	Slip-ring Block Brush Position Adjustment	6-28

7. TORQUE SYSTEM ALIGNMENT

7-1.	S Brake Torque Adjustment	7-1
7-2.	T Brake Torque Adjustment	7-2
7-3.	Sub Brake Adjustment	7-3
7-3-1.	Sub Brake Torque Adjustment	7-3
7-3-2.	Sub Brake Release Adjustment	7-4
7-4.	Reel Motor Current Sensitive Adjustment	7-6
7-4-1.	S Reel Motor Current Sensitive Adjustment	7-6
7-4-1.	T Reel Motor Current Sensitive Adjustment	7-7
7-5.	FWD Back Tension Adjustment	7-8

8. TAPE RUN ALIGNMENT

8-1.	T Correction Guide Slantness Adjustment	8-1
8-2.	PLAY Mode Tape Path Adjustment (1)	8-2
8-3.	PLAY Mode Tape Path Adjustment (2)	8-3
8-4.	FF/REW Mode Tape Path Adjustment	8-4
8-5.	FWD×5/REV×5 Search Mode Tape Path Adjustment	8-5
8-6.	Full Erase Head Zenith Adjustment	8-6
8-7.	Audio Head Zenith Adjustment	8-7
8-8.	Time Code Head Adjustment	8-8
8-8-1.	Time Code Head Zenith Adjustment	8-8
8-8-2.	Time Code Head Azimuth Adjustment	8-9
8-8-3.	Time Code Head Head-to-tape Contact Adjustment	8-9
8-9.	Tracking Adjustment	8-10

8-9-1.	Video Tracking Adjustment	8-11
8-9-2.	Audio Head Height Adjustment	8-14
8-9-3.	Audio Head Azimuth Adjustment	8-15
8-9-4.	Audio Head Phase Adjustment	8-15
8-9-5.	Audio/CTL Head Position Adjustment	8-16
8-9-6.	Time Code Head Height Adjustment	8-17
8-9-7.	Time Code Head Position Adjustment	8-18
8-9-8.	Switching Position Adjustment	8-19
8-9-9.	Drum Phase Adjustment	8-20
8-10.	Video Head Dihedral Adjustment	8-24

9. POWER SUPPLY/SYSTEM CONTROL ALIGNMENT

9-1.	DC Voltage Regulator (UR-21) adjustment	9-1
9-2.	Tape Sensor Balance Adjustment	9-2

10. SERVO SYSTEM ALIGNMENT

10-1.	D/A Amplitude Adjustment	10-2
10-2.	Vertical Sep EN Pulse Adjustment	10-2
10-3.	Capstan FG Bias Adjustment	10-3
10-4.	Drum Free Speed Adjustment	10-4
10-5.	Tracking Control Adjustment	10-5
10-6.	SKEW Control Adjustment	10-5
10-7.	Reel FG Bias Adjustment	10-5
10-8.	Capstan Free Speed Adjustment	10-6
10-9.	Capstan Acceleration Compensation Adjustment	10-6
10-10.	Tracking Control Center Adjustment	10-6
10-11.	RE Muting Pulse Adjustment	10-7
10-12.	REF 135° Burst Pulse Adjustment	10-8
10-13.	PB 135° Burst Pulse Adjustment	10-8
10-14.	Picture Splitting Compensator Adjustment	10-9
10-15.	Reel FG Bias Adjustment	10-14
10-16.	SKEW Center Adjustment	10-15
10-17.	Capstan FG Duty Adjustment	10-16
10-18.	Drum Free Speed Adjustment	10-18
10-19.	Capstan Free Speed Adjustment	10-19
10-20.	135° Burst Pulse Adjustment	10-20
10-21.	Picture Splitting Compensator Adjustment	10-21

11. AUDIO SYSTEM ALIGNMENT

11-1.	Audio REC Level Setting	11-2
11-2.	Audio Output Level Adjustment	11-2
11-3.	Audio Monitor Output Level Adjustment	11-2
11-4.	Audio Level Meter Adjustment	11-3
11-5.	Limiters Level Adjustment	11-3
11-6.	PB Frequency Response Adjustment	11-3

11-7.	PB Output Level Adjustment	11-4
11-8.	Audio PB Level Setting	11-4
11-9.	Spectral Skewing Adjustment	11-4
11-10.	PB Pilot Tone Level Adjustment	11-5
11-11.	PB Pilot Tone Phase Adjustment	11-5
11-12.	Pilot Tone Detect DC Balance Adjustment	11-5
11-13.	Dolby Detect Level Adjustment	11-6
11-14.	Insert Mode Erase Current Adjustment	11-6
11-15.	Audio Erase Pre-adjustment	11-7
11-16.	Bias Level Pre-adjustment	11-7
11-17.	Bias Oscillator Tuning Adjustment	11-8
11-18.	Bias Trap Adjustment	11-8
11-19.	Insert Bias Trap Adjustment	11-8
11-20.	REC Bias Current Level Adjustment (SP)	11-9
11-21.	REC Bias Current Level Adjustment (Conventional)	11-9
11-22.	REC Frequency Response Adjustment (SP)	11-9
11-23.	REC Frequency Response Adjustment (Conventional)	11-10
11-24.	REC Level Adjustment (SP)	11-10
11-25.	REC Level Adjustment (Conventional)	11-10
11-26.	CH-1 Insert Crosstalk Cancel Adjustment	11-11
11-27.	CH-2 Insert Crosstalk Cancel Adjustment	11-11
11-28.	Dolby Detect Inhibit Adjustment	11-11
11-29.	Pilot Tone REC Level Adjustment	11-12
11-30.	Pilot Tone REC Phase Adjustment	11-12
11-31.	Insert 20kHz Trap Adjustment	11-13

12. VIDEO SYSTEM ALIGNMENT

12-1.	PB RF Frequency Response Adjustment (1)	12-2
12-2.	Audio Bias Trap Adjustment	12-3
12-3.	Dropout Compensation Sensitivity Adjustment	12-4
12-4.	RF Amplifier DC Balance Adjustment	12-4
12-5.	Y RF Output Balance Adjustment	12-5
12-6.	Y RF Output Level Adjustment	12-5
12-7.	PB Chroma RF Balance Adjustment	12-6
12-8.	PB RF Frequency Response Adjustment (2)	12-6
12-9.	Carrier Balance Adjustment	12-7
12-10.	SP Mode Detection Adjustment	12-7
12-11.	Y Phase Equalizing Pre-Adjustment (SP Mode)	12-8
12-12.	Y Phase Equalizing Pre-Adjustment	

SECTION 1 INSTALLATION

Ensure that the BVU-950P is installed in an area which has a working environment as described below. Only in this way can you be assured that the superior performance of the unit, together with ease of access for maintenance, will be maintained.

1-1. OPERATIONAL ENVIRONMENT

- . Avoid areas where the BVU-950P will be exposed to direct sunlight, or other strong direct lights.
- . Avoid installation in dusty areas or areas where it will be subject to vibration.
- . Avoid areas where strong electric or magnetic fields are to be found.
- . To prevent overheating of the BVU-950P, ensure that there is good air circulation around the unit. Ensure that the ventilation holes in the top and rear panels are not blocked.
- . Avoid installation in a location near heat sources. The unit should only be operated in a temperature range from 5°C to 40°C.

1-2. INSTALLATION SPACE

- . The dimensions of the unit are shown in the figure below.
- . The rear of the unit must be at least 40 cm away from the wall for ventilation and maintenance.
- . If the BVU-950P is operated on a desk or in a similar environment, ensure that the vertical clearance above the unit is at least 40 cm to allow for easy access to the printed circuit boards and mechanical parts. This space is not necessary if the unit is mounted in a 19-inch rack or console because the printed circuit boards can be repaired after the unit is pulled out.

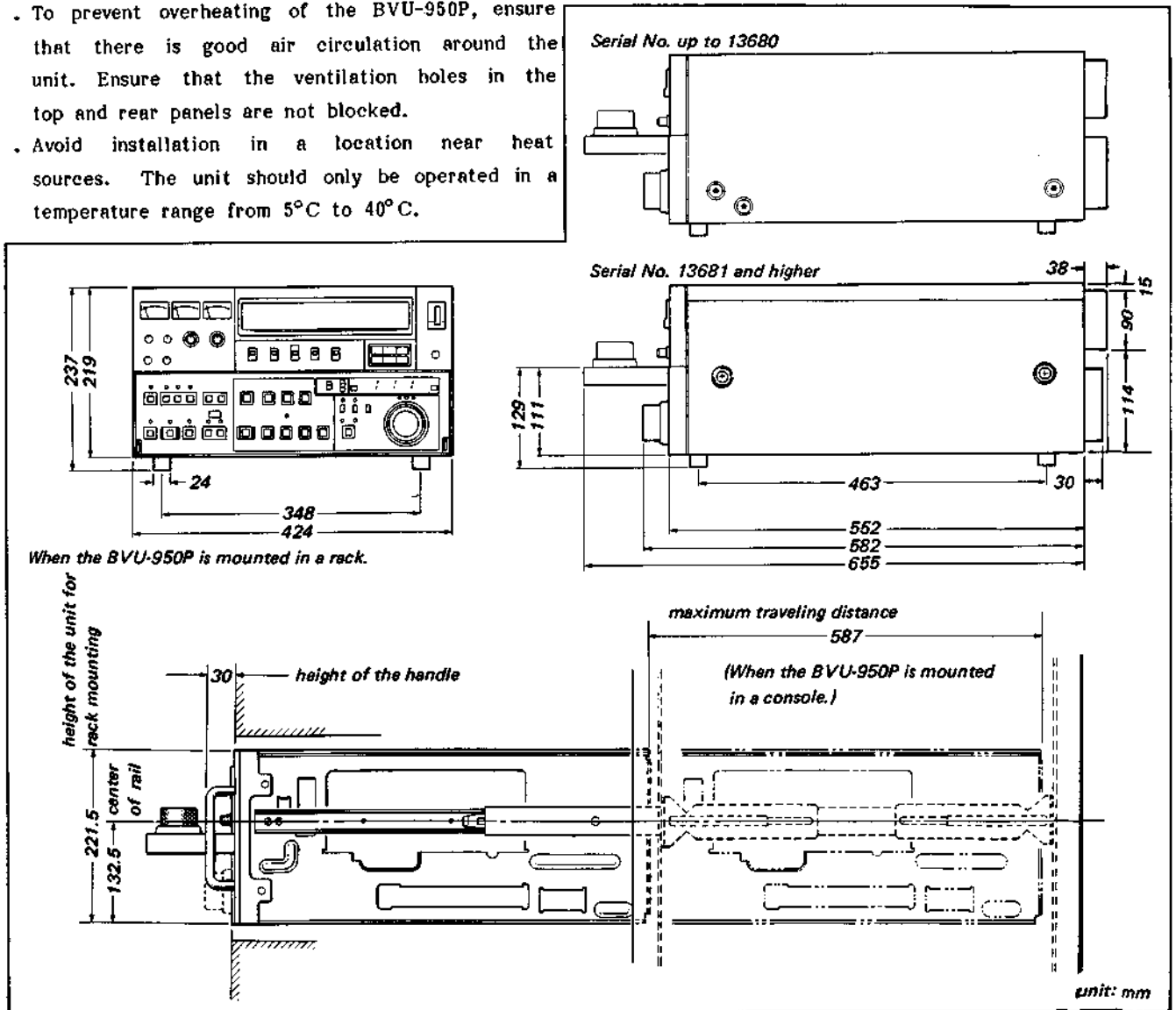

1-3. INPUT/OUTPUT SIGNAL OF THE CONNECTOR

The input and output signals of the main connectors on the connector panel are as follows:

INPUT

VIDEO IN : 1.0 \pm 0.3 Vp-p, sync negative, 75 Ohms, unbalanced

DUB IN : Luminance signal:
0.5 \pm 0.2 Vp-p,
sync negative,
impedance 75 Ohms \pm 10 %
Chroma signal:
0.5 \pm 0.1 Vp-p,
impedance 75 Ohms \pm 10 %

REF VIDEO IN : 1.0 \pm 0.2 Vp-p, 75 Ohms, unbalanced

(EXT SYNC IN : 0.2 Vp-p to 5 Vp-p, negative, 75 Ohms, unbalanced)

AUDIO IN : LOW:
-60 dB, 3 k Ohms, balanced
HIGH:
+4 dB, 10 k Ohms/600 Ohms, balanced

TIME CODE IN : 0 \pm 6 dB, 10 k Ohms, unbalanced (0 dB = 1.55 Vp-p pulse)

OUTPUT

VIDEO OUT 1/2 : 1.0 \pm 0.2 Vp-p, sync negative, 75 Ohms, unbalanced

DUB OUT : Luminance signal:
0.5 \pm 0.2 Vp-p,
sync negative,
impedance 75 Ohms \pm 10 %
Chroma signal:
0.5 \pm 0.1 Vp-p,
impedance 75 Ohms \pm 10 %

RF (OFF TAPE) : 0.5 Vp-p, 75 Ohms, unbalanced

AUDIO OUT : LINE:
+4 dBm, balanced,
600 Ohm load
MONITOR:
+4 dBm, balanced,
600 Ohm load

HEADPHONES:

-46 dB to -26 dB,
8 Ohm load, stereo

TIME CODE OUT : 0 \pm 3 dB, low impedance, unbalanced

(0 dB = 1.55 Vp-p pulse)

REF VIDEO OUT : Without the TBC Board:
No output

With the TBC Board and an input signal at REF VIDEO IN:
Same level as REF VIDEO IN
(1.0 \pm 0.2 Vp-p), 75 Ohms, unbalanced

With the TBC Board, but without an input signal at REF VIDEO IN:
B.S. (0.3 Vp-p/0.3 Vp-p),
75 Ohms, unbalanced

MONITOR

VIDEO : 1.0 \pm 0.2 Vp-p, sync negative, 75 Ohms, unbalanced

8P

Pin	I/O Signal
1	AUDIO MONITOR OUT (X)
2	VIDEO OUT (X)
3	NC
4	NC
5	AUDIO MONITOR OUT (G)
6	VIDEO OUT (G)
7	NC
8	NC

REMOTE CONTROL

REMOTE 1 (9P)

Pin	Description	I/O
1	FRAME GND	—
2	TRANSMIT A	O
3	RECEIVE B	I
4	RECEIVE COMMON	—
5	SPARE	—
6	TRANSMIT COMMON	—
7	TRANSMIT B	O
8	RECEIVE A	I
9	FRAME GND	—

REMOTE 2 (24P)

Pin	I/O Signal	Specification
1	+5 V OUT	MAX. 100 mA
2	L-STOP COMMAND IN	L: less than 1.5 V, H: more than 3.5 V, pulse width is more than 50 msec.
3	L-F FWD COMMAND IN	L: less than 1.5 V, H: more than 3.5 V, pulse width is more than 50 msec.
4	L-PLAY COMMAND IN	L: less than 1.5 V, H: more than 3.5 V, pulse width is more than 50 msec.
5	L-REW COMMAND IN	L: less than 1.5 V, H: more than 3.5 V, pulse width is more than 50 msec.
6	L-STANDBY COMMAND IN	L: less than 1.5 V, H: more than 3.5 V, pulse width is more than 50 msec.
7	L-EJECT COMMAND IN	L: less than 1.5 V, H: more than 3.5 V, pulse width is more than 50 msec.
8	L-REC COMMAND IN	L: less than 1.5 V, H: more than 3.5 V, pulse width is more than 50 msec.
9	L-STOP STATUS OUT	L: 0.8 V (less than 8 mA), H: 4.7 k Ohms pullup resistor
10	L-F FWD STATUS OUT	L: 0.8 V (less than 8 mA), H: 4.7 k Ohms pullup resistor
11	L-PLAY STATUS OUT	L: 0.8 V (less than 8 mA), H: 4.7 k Ohms pullup resistor
12	L-REW STATUS OUT	L: 0.8 V (less than 8 mA), H: 4.7 k Ohms pullup resistor
13	L-STANDBY STATUS OUT	L: 0.8 V (less than 8 mA), H: 4.7 k Ohms pullup resistor
14	L-CASSETTE IN STATUS OUT	L: 0.8 V (less than 8 mA), H: 4.7 k Ohms pullup resistor
15	L-REC STATUS OUT	L: 0.8 V (less than 8 mA), H: 4.7 k Ohms pullup resistor
16	L-FREEZE COMMAND IN	L: less than 1.5 V, H: more than 3.5 V, pulse width is more than 50 msec.
17	NC	
18	NC	
19	NC	
20	NC	
21	NC	
22	NC	
23	NC	
24	GND	

TBC REMOTE

Pin	I/O Signal
1	SYNC CONTROL IN
2	HUE CONTROL IN
3	SC CONTROL IN
4	VIDEO LEVEL CONTROL IN
5	SET UP CONTROL IN
6	CHROMA LEVEL CONTROL IN
7	-12 V OUT
8	GND
9	FRAME GND
10	NC
11	NC
12	NC
13	NC
14	NC
15	+12 V OUT

1-4. CONNECTION CONNECTOR

When external cables are connected to various connectors on the BVU-950P connector panel during installation or maintenance, the hardware listed below (or equivalent) must be used.

Panel Indication	Connector
VIDEO IN REF VIDEO IN VIDEO OUT 1/2 RF (OFF TAPE) REF VIDEO OUT MONITOR VIDEO	1-560-069-11 PLUG, BNC, MALE
TIME CODE	1-560-069-11 PLUG, BNC, MALE
DUB IN	1-561-055-00 PLUG, 7P, FEMALE
DUB OUT	1-508-948-00 PLUG, 7P, MALE
AUDIO IN	1-508-084-00 CONNECTOR, 3P, MALE
AUDIO OUT	1-508-083-00 CONNECTOR, 3P, FEMALE
MONITOR	1-506-161-00 CONNECTOR, 8P, MALE
TBC REMOTE	1-508-495-00 PLUG, 9P, MALE
REMOTE 1	1-560-651-00 PLUG, 9P(M) and 1-561-749-00 JUNCTION SHELL, 9P
REMOTE 2	1-506-897-11 CONNECTOR, 24P, MALE

1-5. SELECT SWITCH SETTING

Along with the select switches on the control panel and the connector panel, the switches listed below are on the circuit boards. These switches must be set according to operating conditions.

. DM-55 Board

(i) S301, S302: SP DET sw

These switches can select the detection speed in the automatic detection circuit of the playback video signals mode.

S301 and S302 are ON:

High speed detection mode

S301 and S302 are OFF:

Normal speed detection mode

When the unit is shipped, they are set to OFF position.

If they are set to ON positions and playback the tape which is inserted SP mode and conventional mode alternately, prevent the the DC shift at cut in/cut out point. However, the detection circuit may be malfunction by the video signals.

These switches should be set to OFF positions in the normal use.

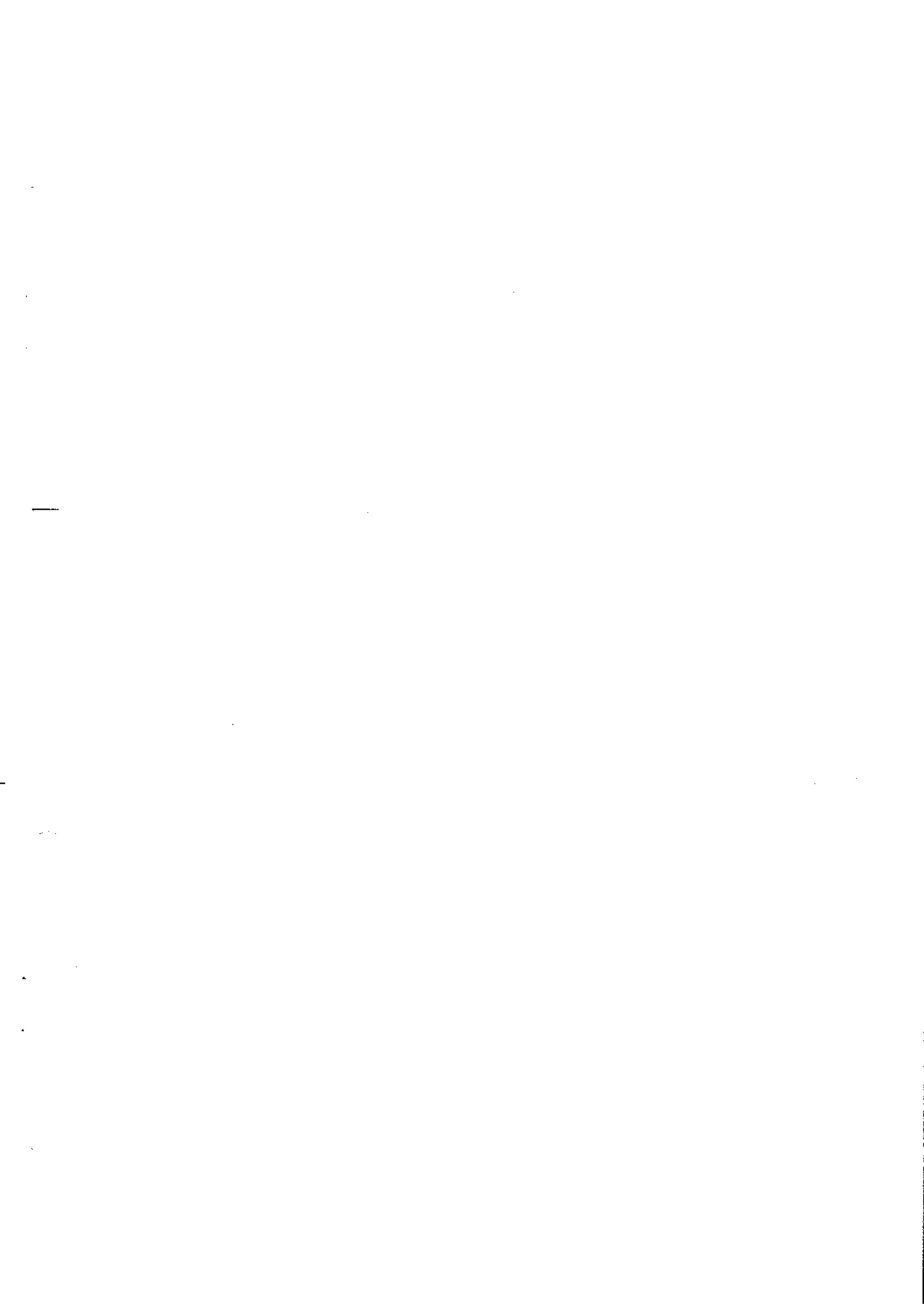

S/N UP TO 13730

. SV-88A Board

There are two switches, S201 and S202 on the SV-88A Board and they are closely related.

- (i) S201 Bit7: ON
Bit8: OFF

S202: OFF

A emergency circuit for reel stop, tape slack, capstan error, drum stop and so on is not functioned in this mode. This mode is used in the mechanical alignment.

This mode is not set at the same time as the following items (ii) and (iii).

- (ii) S201 Bit7: ON
Bit8: OFF

S202: ON

Set this mode, when operate the unit without installing the Cassette-up Compartment and cassette tape for the mechanical alignment.

This mode is not set at the same time as the items (i) and (iii).

- (iii) S201 Bit 7: OFF
Bit 8: ON

S202: OFF

This mode release the H-lock mode.

This mode is not set at the same time as the above items (i) and (ii).

- (iv) S201 Bit5: ON
Bit6: ON

S202: ON

This mode is set for the sensitive alignment of the reel torque without the cassette tape.

- (v) S201 Bit3: ON
Bit4: OFF

S202: OFF

Set this mode, when the tape without recording the CTL signal is played back, the capstan rotate under the same state as recorded.

- (vi) S201 Bit1: OFF
Bit2: ON

S202: OFF

This mode cancel the function of phi-square circuit.

When the unit is shipped, all switches, S201 and S202 are set to the OFF positions.

S/N 13731 AND HIGHER

- SV-113 Board

There are two switches, S101 and S301 on the SV-113 Board and they are closely related.

(i) S101 Bit7: ON

S301: OFF

A emergency circuit for reel stop, tape slack, capstan error, drum stop and so on is not functioned in this mode. This mode is used in the mechanical alignment.

This mode is not set at the same time as the following items (ii) and (iii).

(ii) S101 Bit7: ON

S301: ON

Set this mode, when operate the unit without installing the Cassette-up Compartment and cassette tape for the mechanical alignment.

This mode is not set at the same time as the items (i) and (iii).

(iii) S101 Bit7: OFF

S301: OFF

This mode release the H-lock mode.

This mode is not set at the same time as the above items (i) and (ii).

(iv) S101 Bit5: ON

Bit6: ON

S301: ON

This mode is set for the sensitive alignment of the reel torque without the cassette tape.

(v) S101 Bit3: ON

S301: OFF

Set this mode, when the tape without recording the CTL signal is played back, the capstan rotate under the same state as recorded.

(vi) S101 Bit2: ON

S301: OFF

This mode cancel the function of phi-square circuit.

When the unit is shipped, all switches, S101 and S301 are set to the OFF positions.

1-6. DIAL MENU OPERATION

Various select switches are provided on the Front Panel and printed circuit board (refer to Section 1-5 "Select Switch Setting"). The system controls (Still Timer, Preroll Time, etc.) initially set at the factory can be arbitrarily modified using the SEARCH dial, MENU button, DATA button, and SET button as in Section 1-5 Select Switch Setting.

The dial menu has the following functions:

- . BASIC FUNCTION
- . ENHANCED FUNCTION

1-6-1. Button and Dial Settings

Search dial: Selects the ITEM, Modifies the DATA, Moves the cursor.

MENU button: Selects the ITEM when used with a search dial.

DATA button: Selects the DATA when used with a search dial.

SET button : Writes the DATA into the memory.

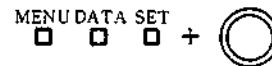

1-6-2. Operation

<Put the unit into DIAL MENU operation mode>

The DIAL MENU operation data appears on the Front Panel's time counter display and monitor television (the video signals should be connected to the VIDEO IN terminal and the monitor television should be connected to the MONITOR OUT terminal on the Connector Panel).

Do not communicate between two VTRs (the RECORDER/PLAYER lamp on the Front Panel is off).

- (1) Set the REMOTE/LOCAL switch on the front panel to LOCAL.
- (2) Put the unit into JOG mode (when the SHUTTLE lamp is on, press the SEARCH dial).
- (3) Press the STOP button and put into the STOP mode.

- (4) Set the CTL/TC/DIAL MENU switch on the Front Panel to DIAL MENU.
The unit is put into the DIAL MENU mode and the ◁□▷ lamp at the top of the SEARCH dial lights.

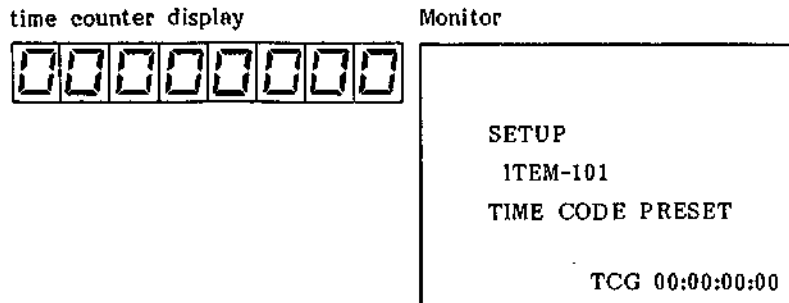

When the unit is put into the DIAL MENU mode after the power on sequence, the following ITEM is selected automatically.

When the optional time code (BKU-905) is installed into the unit :
ITEM-101

When the optional time code (BKU-905) is not installed into the unit :
ITEM-103

(NOTE) The VTR cannot be operated normally in the DIAL MENU operation mode.
However, the PB. PB/EE select switch can be used in this mode.

◁Select the ITEM▷

- (5) Turn the search dial while pressing the MENU button.

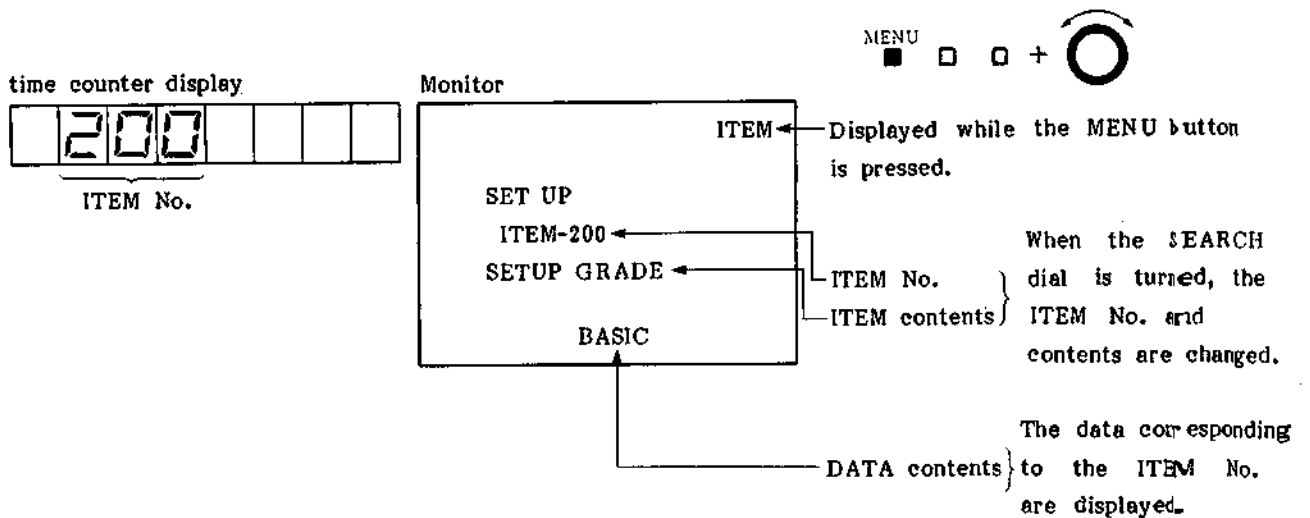

(6) Stop the dial when the desired ITEM is displayed, and then release the MENU button.

When the DATA No. on the time counter display and DATA contents on the monitor blink, they can be modified as following method.

<Modify the data>

(7) Turn the dial while pressing the DATA button.

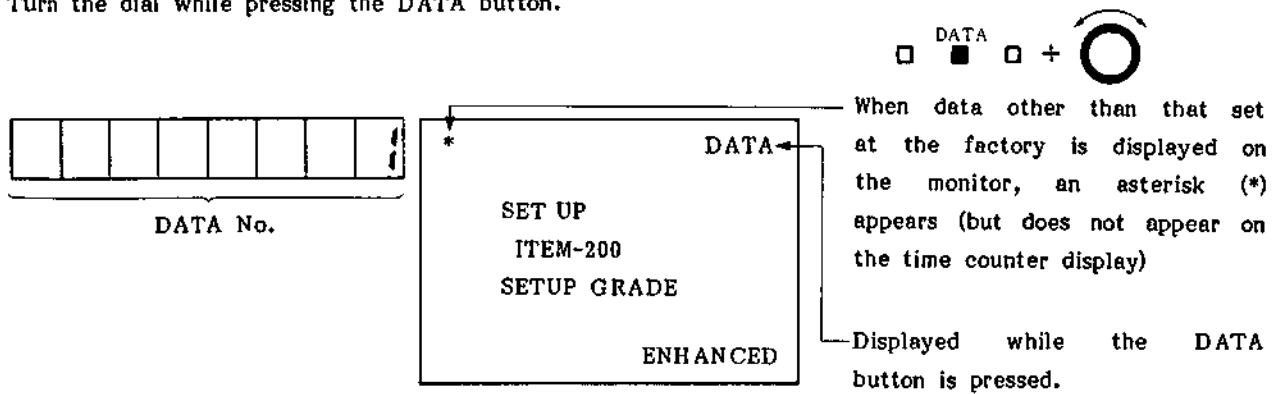

(8) Stop the dial when the desired data is displayed, and release the DATA button.

<Set the data>

(9) Press the SET button.

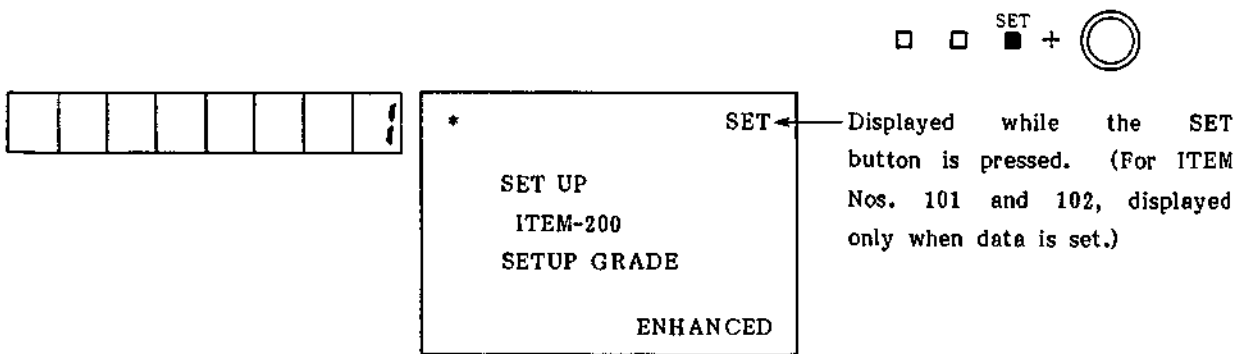

- . The displayed data is written into the memory, the data remains unchanged even if the POWER switch is turned OFF.
- . If the updated data is set, the <□> lamp at the top of the SEARCH dial flashes for one second when the SET button is pressed. The DATA No. and DATA content blinking stops at that time.

1-6-3. ITEM/DATA

(1) BASIC FUNCTION

(NOTE) ITEM Nos. 101 and 102 are displayed only when an optional time code, BKU-905 is installed into the VTR.

Item		Data		Item and Data Description
ITEM NO. time counter	ITEM content monitor display	DATA NO. time counter	DATA content monitor display	
101	TIME CODE PRESET	00000000 23595924	TCG 00:00 :00:00 TCG 23:59 :59:24	Time code setting. 00H00M00S00Fr through 23H59M59S24Fr can be set. Factory setting: DATA No.00000000 (TCG00:00:00:00)

Setting the data in the ITEM No. 101

(NOTE). Set the INT/EXT switch on the Sub-control Panel to INT.
. Set the SLAVE LOCK/PRESET switch on the Sub-control Panel to PRESET.

1. Turn the SEARCH dial and flash the desired digit.

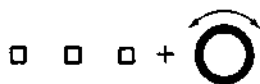

2. Turn the dial while pressing the DATA button to set the desired figures.

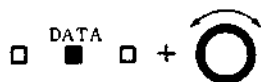

3. Repeat the steps 1, 2 to set the desired figures.
4. When completed, press the SET button.

Item		Data		Item and Data Description
ITEM NO. time counter	ITEM content monitor display	DATA NO. time counter	DATA content monitor display	
102	U-BIT PRESET	00000000 FFFFFFFF	00 00 00 00 FF FF FF FF	User bit setting. Eight-digit data (hexadecimal) can be recorded into a tape. Data setting is the same as in ITEM No.101. Factory setting: DATA No.00000000 (00 00 00 00)
103	TITLE (SMALL)	-----		The time code character and title are set in a small letter (for details, refer to Section 1-7).
104	TITLE (LARGE)	-----		The time code character and title are set in a capital letter (for details, refer to Section 1-7).
200	SETUP GRADE	0 1	BASIC ENHANCED	DATA No.0 BASIC:Enable to select ITEM from 101 to 200 in the DIAL MENU operation. DATA No.1 ENHANCED: Enable to select ITEM from 101 to 219 in the DIAL MENU operation. Factory setting: DATA No.0 (BASIC)

(2) ENHANCED FUNCTION

The ENHANCED FUNCTION can be used by setting data to ENHANCED in the ITEM No. 200.

(NOTE) ITEM Nos. 203, and 204 are displayed only when an optional time code, BKU-905 is installed into the VTR.

Item		Data		Item and Data Description
ITEM NO. time counter	ITEM content monitor display	DATA NO. time counter	DATA content monitor display	
201	ERROR STATUS	Error 01 Error 02 Error 03 Error 04 Error 05 Error 10 Error 20 Error 30	REEL STOP TAPE SLACK CAPSTAN ERROR DRUM STOP REEL ERROR HUMID SYSTEM ERROR SENSOR ERROR	<p>Self-diagnostic function. When trouble occurs during normal operation, message "ERROR CODE" appears on the Front Panel's time counter display in any mode. When the unit is put into the DIAL MENU mode to select this ITEM, error status corresponding to the error code are displayed on the monitor. (Refer to Section 1-6-4 for further details.)</p> <p>Note: The ITEM data content cannot be modified.</p> <p>Normal operation: ----- (NONE)</p>

mmmmmm

Item		Data		Item and Data Description
ITEM NO. time counter	ITEM content monitor display	DATA NO. time counter	DATA content monitor display	
203	PHASE CORRECTION	0 1	OFF ON	<p>Selects whether or not the phase correction of the LTC signal generated using a time code generator should be controlled.</p> <p>DATA No.0 OFF: No phase correction is controlled. DATA No.1 ON: The phase correction is controlled.</p> <p>Factory setting: DATA No.1 (ON)</p>
204	U-BIT BINARY GROUP FLAG	00 01 10 11	NOT SPECIFIED ISO CHARACTER UNASSIGNED1 UNASSIGNED2	<p>Sets the user bit status of the time code signal generated using a time code generator.</p> <p>DATA No.00 NOT SPECIFIED: Character setting is not specified.</p> <p>DATA No.01 ISO CHARACTER: 8-bit character setting based on ISO646 and ISO2022.</p> <p>DATA No.10 UNASSIGNED1: Undefined DATA No.11 UNASSIGNED2: Undefined</p> <p>Factory setting: DATA No.00 (NOT SPECIFIED)</p>

Item		Data		Item and Data Description
ITEM NO. time counter	ITEM content monitor display	DATA NO. time counter	DATA content monitor display	
205	HOUR METER (DRUM)	00000 15000H	00000H 15000H	Displays the rotation time of the upper drum. Head replacement can be detected at that time. Up to from 0H to 15000H can be displayed. Note: The ITEM data content cannot be modified.
206	HOUR METER	00000 15000	00000H 15000H	Displays the total time of the power on sequence. Up to from 0H to 15000H can be displayed. Note: The ITEM data content cannot be modified.
207	STILL TIMER	00 01 02 03 04 05 06 07 08 09 10 11 12 13 14 15	0.5 SEC 1 SEC 5 SEC 10 SEC 20 SEC 30 SEC 40 SEC 50 SEC 1 MIN 2 MIN 3 MIN 4 MIN 5 MIN 6 MIN 7 MIN 8 MIN	The unit automatically enters the tape PROTECTION mode after it has been in the tape STOP (or STILL) mode for a fixed time to prevent the video head from clogging (to reduce the tape damage). This item sets the transition time of the tape STOP to tape PROTECTION mode. The time can be set from 0.5 seconds to 8 minutes. Factory setting: DATA No.15 (8 MIN)
208	TAPE PROTECTION MODE	0 1	STEP FWD STANDBY OFF	When the time in the SEARCH STILL mode set using ITEM No.207 passes, selects the mode setting. DATA No.0 STEP FWD: The tape is sent repeatedly for one second at 1/30 times normal speed in the forward direction. DATA No.1 STANDBY OFF: Enters the STANDBY OFF mode. Factory setting: DATA NO.0 (STEP FWD)

Item		Data		Item and Data Description
ITEM NO. time counter	ITEM content monitor display	DATA NO. time counter	DATA content monitor display	
209	SELECTION FOR SEARCH DIAL ENABLE	0 1	DIAL DIRECT VIA SEARCH BUTTON	<p>When the SEARCH dial is turned or the SEARCH button is pressed, the unit enters the SEARCH mode. This item sets entering the SEARCH mode.</p> <p>DATA No.0 DIAL DIRECT: When the SEARCH dial is turned, the unit enters the SEARCH mode from any mode other than REC/EDIT.</p> <p>DATA No.1 VIA SEARCH BUTTON: When the SEARCH button is pressed, the unit enters the SEARCH mode.</p> <p>Factory setting: DATA No.0 (DIAL DIRECT)</p>
210	DRUM ROTATION IN STAND- BY OFF	0 1	OFF ON	<p>Sets the drum status in the STANDBY OFF mode.</p> <p>DATA No.0 OFF: The drum rotation stops. DATA No.1 ON: The drum is rotated.</p> <p>Factory setting: DATA NO.0 (OFF)</p>
211	TAPE TIMER DISPLAY	0 1	+/-12H 24H	<p>Selects whether the CTL counter should be displayed by ±12H or 24H.</p> <p>DATA No.0 +/-12H: Displayed by ±12H. DATA No.1 24H: Displayed by 24H.</p> <p>Factory setting: DATA No.0 (+/-12H)</p>

Item		Data		Item and Data Description
ITEM NO. time counter	ITEM content monitor display	DATA NO. time counter	DATA content monitor display	
212	AUTO EE SELECT	0 1	STOP/F FWD /REW STOP	<p>When the PB.PB/EE select switch on the Function Control Panel is set to PB/EE, sets the mode in which an EE picture appears on the monitor connected to the VTR.</p> <p>DATA No.0 STOP/F FWD /REW: The EE picture appears in the STOP, F FWD, and REW modes.</p> <p>DATA No.1 STOP: The EE picture appears only in the STOP mode.</p> <p>Factory setting: DATA No.0 (STOP/F FWD/REW)</p>
213	MONITORING SELECTION FOR VTR TO VTR EDIT	0 1	RECORDER ONLY AUTO SWITCH	<p>When one monitor television is connected to the recorder during tape editing with two VTRs, selects whether the picture from the player can be played back, irrespective of its PB.PB/EE select switch setting.</p> <p>DATA No.0 RECORDER ONLY: The picture cannot be played back.</p> <p>DATA No.1 AUTO SWITCH: When the PLAYER button on the Front Panel is pressed, the picture can be played back.</p> <p>(NOTE) When the two VTRs are connected through the dubbing connectors, unstabilized picture appears in the playback mode. Please connect the VTRs using by the VIDEO IN/OUT connectors.</p> <p>Factory setting: DATA No.0 (RECORDER ONLY)</p>

Item		Data		Item and Data Description
ITEM NO. time counter	ITEM content monitor display	DATA NO. time counter	DATA content monitor display	
214	PREROLL TIME	00 01 02 03 04 05 06 07 08 09 10 11 12 13 14 15	0 SEC 1 SEC 2 SEC 3 SEC 4 SEC 5 SEC 6 SEC 7 SEC 8 SEC 9 SEC 10 SEC 11 SEC 12 SEC 13 SEC 14 SEC 15 SEC	<p>Sets the preroll time during editing. The preroll time can be set from 0 to 15 seconds.</p> <p>Factory setting: DATA No.05 (5 SEC)</p>
215	AUTOMATIC PREROLL REFERENCE ENTRY	0 1	DISABLE ENABLE	<p>When the PREROLL button is pressed without pressing the IN point button during editing, the position is automatically entered as an IN point and prerolled for the time set using ITEM No.214.</p> <p>This item selects whether the IN point is automatically entered when the PREROLL button is pressed.</p> <p>DATA No.0 DISABLE: The IN point is not entered automatically.</p> <p>DATA No.1 ENABLE: The IN point is entered automatically.</p> <p>Factory setting: DATA No.1 (ENABLE)</p>
216	SYNCHRONIZE	0 1	OFF ON	<p>When communicate between two VTRs, synchronization can be done to correct the deviation at an IN point during preview or AUTO editing. This item selects whether or not the synchronization should be done.</p> <p>DATA No.0 OFF: Not synchronized.</p> <p>DATA No.1 ON: Synchronized.</p> <p>Factory setting: DATA No.0 (OFF)</p>

Item		Data		Item and Data Description
ITEM NO. time counter	ITEM content monitor display	DATA NO. time counter	DATA content monitor display	
217	EDIT DELAY	0 1	2FRAME 6FRAME	<p>Receives a recording command from the remote control unit during tape editing and selects the number of frames required until the VTR starts recording.</p> <p>DATA No.0 2 FRAME: Starts recording two frames after the command is received. The audio signal is double recorded on the tape at the cut-in point. The form as before.</p> <p>DATA No.1 6 FRAME: Starts recording six frames after the command is received. This compensates the edit timing of audio and video signals. The standard setting of BVU-950P.</p> <p>(NOTE) Set according to the editing machine.</p> <p>Factory setting: DATA No.1 (6 FRAME)</p>
218	PINCH ON DELAY	0 1 2 3 4 5 6 7 8 9 10 11 12 13 14 15	0 1 2 3 4 5 6 7 8 9 10 11 12 13 14 15	<p>Adjusts the time required from PLAY command sending to tape transport.</p> <p>Factory setting: DATA No.7 (7)</p>

Item		Data		Item and Data Description
ITEM NO. time counter	ITEM content monitor display	DATA NO. time counter	DATA content monitor display	
219	LOCAL FUNCTION ENABLE	0 1 2	STOP & EJECT ALL ENABLE ALL DISABLE	<p>When the REMOTE/LOCAL select switch is set to REMOTE, and REMOTE-1/REMOTE-2 switch is set to 9 pin position, selects the function which can be activated using function buttons on the front panel.</p> <p>DATA No.0 STOP & EJECT: Only STOP and EJECT buttons can be activated.</p> <p>DATA No.1 ALL ENABLE: All buttons can be activated.</p> <p>DATA No.2 ALL DISABLE: All buttons cannot be activated.</p> <p>Note: When the unit is remote-controlled using a 24-pin connector, this item does not apply to the above description.</p> <p>Factory setting: DATA No.0 (STOP & EJECT)</p>

Item		Data		Item and Data Description
ITEM NO. time counter	ITEM content monitor display	DATA NO. time counter	DATA content monitor display	
220	FREEZE MODE SW4 SW3 SW2 SW1			Selection of freeze mode
	SW4	1 0		Blank
	SW3	1 0		Blank
	SW2	1 0	ON OFF *	BVR-55 Freeze SW Selection IN Point Auto Freeze SW Manual Freeze SW
	SW1	1 0	ON OFF *	Choice of STAND-BY OFF AUTO FREEZE MODE ON or OFF (ON for freeze)
221	CHARACTER REC SELECT	1 0	ENABLE * DISABLE	Choice of recording of superimposed character (ENABLE for recording, DISABLE for inhibit)

* factory preset

NOTE: In order to utilize the function of ITEM NO.220 by BKU-902/904 or BVR-55, the following procedure should be performed.

1. BKU-902/904

	BKU-902/904	
	former	correction
SW. NO.	COR 301	COR 301
Position of jumper SW.	1	2

2. INT TBC Selector : AUTO

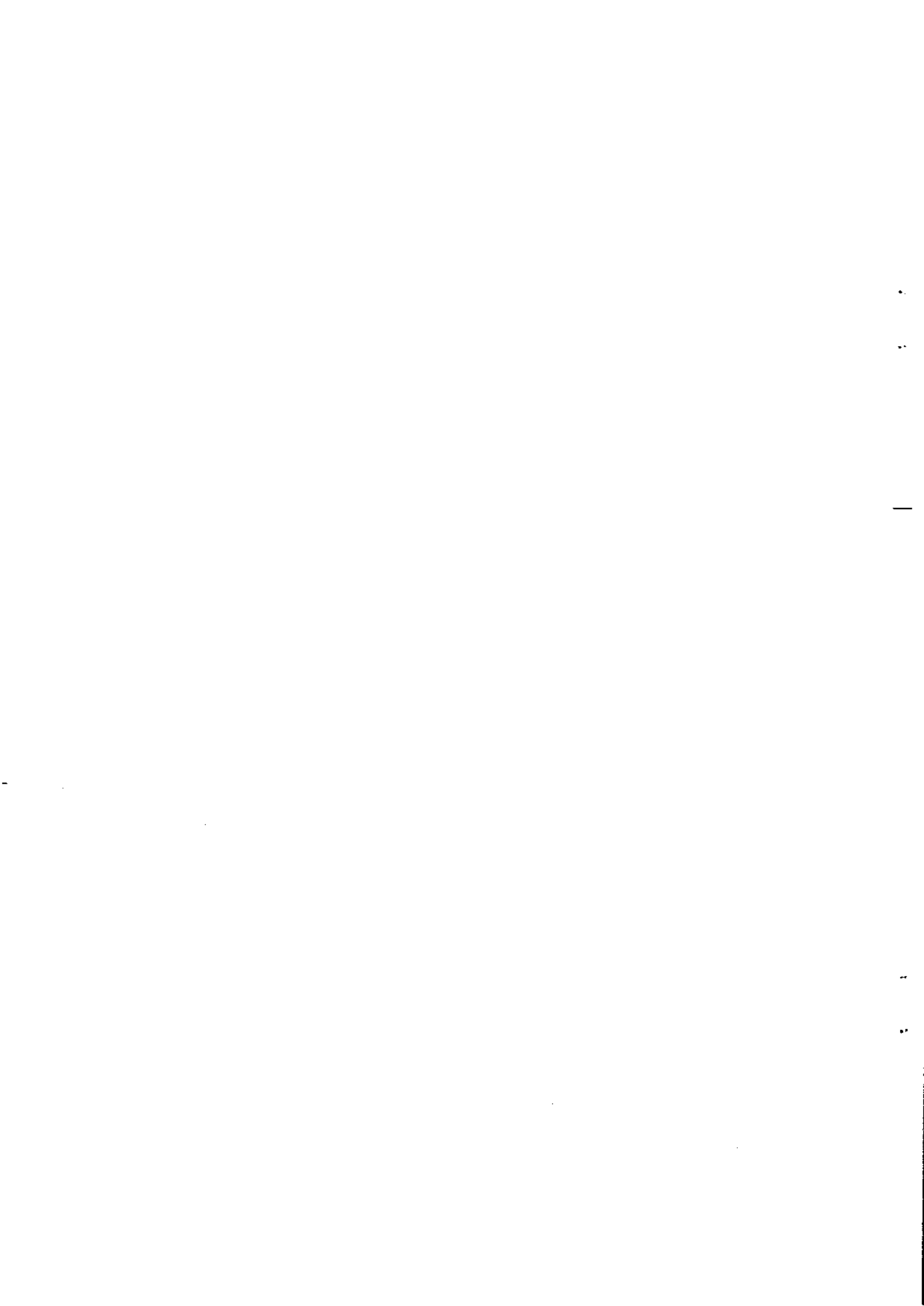

1-6-4. System Error

When a trouble occurs during normal operation and an error code appears on the time counter display of the Front Panel, the error status corresponding to the error code is displayed on the monitor by selecting the Item No. 201 on the dial menu. The error cause can be learned at that time.

counter display	monitor display	Description
Error 01	REEL STOP	In the mode except the STOP and STILL modes, stop rotating the reel motor or direction error.
Error 02	TAPE SLACK	Excessive tape tension
Error 03	CAPSTAN ERROR	In the REC or PLAY mode, speed over of the capstan or stopped it.
Error 04	DRUM STOP	When the drum rotation command is detected, the drum rotation stops.
Error 05	REEL ERROR	The tape runs in speed over.
Error 10	HUMID	The condensation
Error 20	SYSTEM ERROR	Mechanical error. Distinguished by the suberror code. (Refer to the following.)
Error 21	————	RAM error when the POWER is ON.
Error 30	SENSOR ERROR	LED error of the T or S Tension Detector.
Error 90	————	Communication error between SY board and KY board.
Error 99	————	Lacking the 1/2 VD pulse to supply for the SY board.

(NOTE) Displayed on the time counter display about ERROR 21, 90 99.

When Error 20 "SYSTEM ERROR" appears, a suberror code is displayed at the lower right corner on the monitor.

The suberror code is described below.

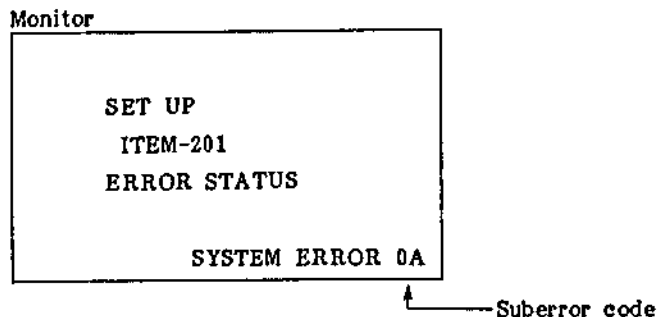

The suberror code is a two-digit hexadecimal number. Assume that the high-order digit is called Error 1 and the low-order digit called Error 0.

Error 0

0.	Normal operation
1.	Entering the FR STOP mode from threading exceeds the prescribed time (seven seconds).
2.	Entering the THREAD END 2 mode from threading exceeds the prescribed time.

3.	Entering the UNTHREAD END mode from the THREAD END 2 mode during unthreading exceeds the prescribed time.
4.	Returning from the FR STOP mode to the CASSETTE DOWN position during unthreading exceeds the prescribed time.
5.	When a cassette is inserted and the EJECT button is pressed before the cassette-up compartment is lowered, raising the cassette exceeds the prescribed time.
6.	The initial correction of a tension sensor is not completed.
7.	No command is sent from the servo block to stop the SHORT FF/REW mode.
8.	No command is sent from the servo block to start the SHORT FF/REW mode.
9.	An error command is sent from the servo block in the SHORT FF/REW mode.
A.	No command is sent from the servo block to turn on the pinch solenoid.
B.	No command is sent from the servo block to turn off the pinch solenoid.
C.	No command is sent from the servo block to stop the FF/REW mode.
D.	The capstan motor is not rotated in reverse to enter the STANDBY OFF mode.
E.	The drum is not rotated to change the mode from STANDBY OFF to STANDBY ON.
F.	No command is sent from the servo block to start threading in the FR STOP mode.

Error 1

0.	Normal operation
1.	Microcomputer M2 is not interrupted by the signal eight times the frequency of the 1/2 VD pulse.
2.	Communication error between microcomputers M2 and AV.
3.	Communication error between microcomputers M2 and SV.
4.	Communication error between microcomputers M1 and M2.

1-7. RECORDING OF TIME CODE CHARACTER AND TITLE

BVU-950P can superimpose the time code character and the title on the picture and then record on the tape in small or capital letter. Set the time code character and the title in the DIAL MENU operation.

1-7-1. Setting the Time Code Character and the Title

<Display the setup picture>

- . Connect the monitor TV to the MONITOR OUT terminal on the connector panel.
 - . Set the CHARACTER switch on the Sub-control Panel to ON.
1. Set the REMOTE/LOCAL switch to LOCAL.
 2. Put the unit into JOG mode.
 3. Press the STOP button and put the unit into STOP mode.
 4. Set the CTL/TC/DIAL MENU switch to DIAL MENU and put the unit into DIAL MENU mode.
 5. Turn the search dial on the Front Panel while pressing the MENU button. Select the ITEM No. 103 TITLE (SMALL).
 6. Release the MENU button. Display the setup picture on the monitor.

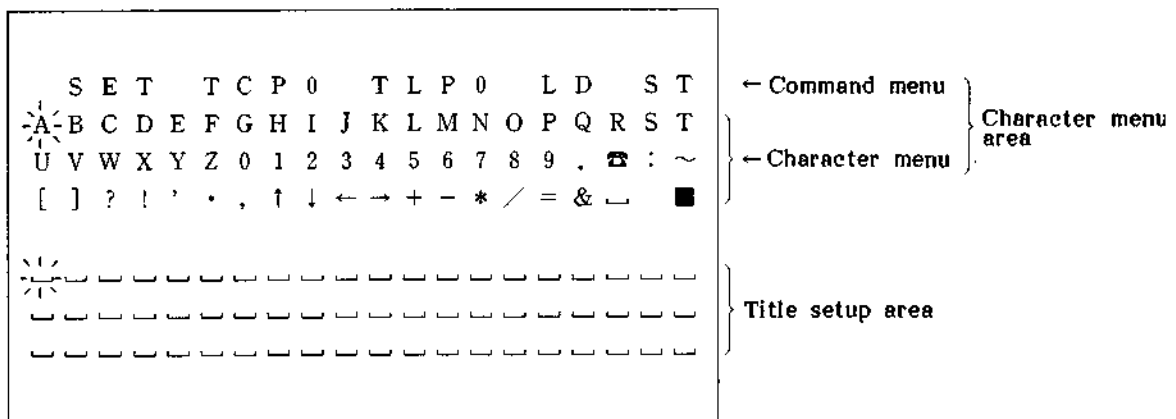

 indicate the cursor

.The setup picture consist of characer menu area and title setup area.

.Chareter menu area: Select the character. Command menu in this area signify.
(Refer to steps 11 to 16.)

.Title setup area: Set the desired title.

(NOTE) Move the cursor in the character menu area



Move the cursor in the title setup area

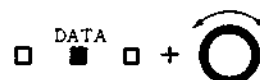

<Setting the title>

7. Turn the dial and move the cursor in the character menu area to the desired character.

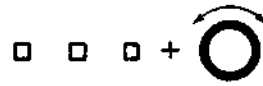
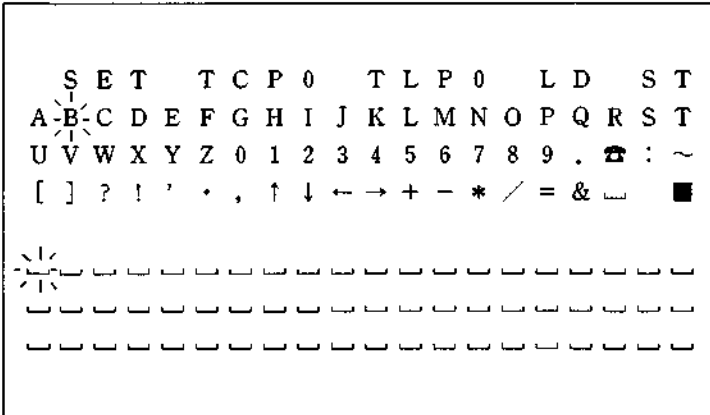

8. Turn the dial while pressing the DATA button.

Move the cursor in the title setup area to set the position where the character will be displayed.

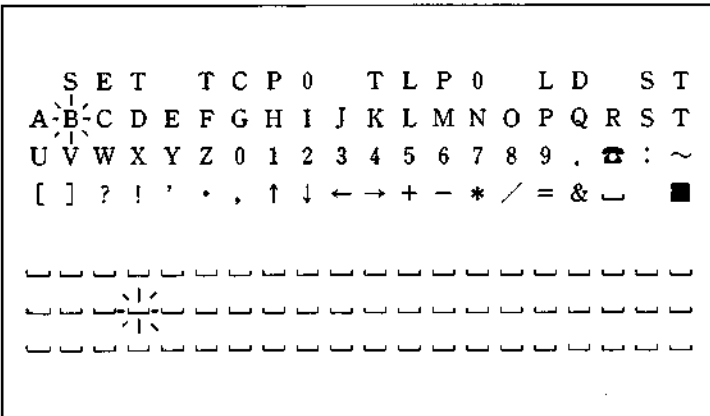

9. Press the SET button on the Front Panel.

The appointed character in the character menu area is displayed at the blinking cursor in the title setup area. The cursor in the title setup area move to right by one character.

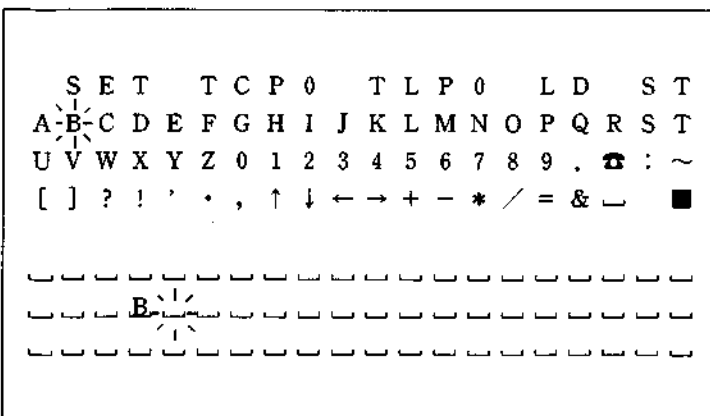

10. Repeat the steps 7 to 9 to set the title one by one.

<Set the position of the time code and title characters>

11. After the title setting is completed, turn the dial and move the cursor in the character menu area to TCP command or TLP command of the command menu.

TCP0

This set the position of the time code character on the display. (Time Code Position)

0 line to 9 lines.

(0 : not display the time code character)

TLP0

This set the position of the title characters on the display. (Title character Position)

0 line to 7 lines.

(0 : not display the title character)

12. Turn the dial while pressing the DATA button and set the position on the display for the characters.

TLP3

This set the position of the title characters on the display. (Title character Position)

0 line to 7 lines.

(0 : not display the title character)

<Decision the title>

13. Turn the dial and move the cursor in the character menu area to SET command.

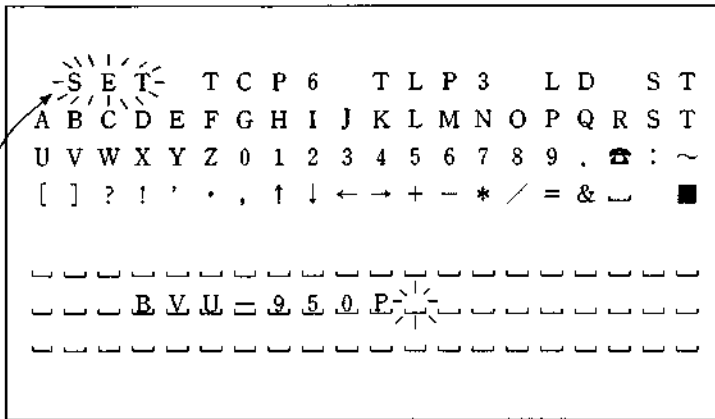

SET

This superimpose the time code character and title on the picture.

Check the characters on the display, then enable to record the characters on the tape.

14. Press the SET button on the Front Panel.
 The setup picture disappears, and the time code character and title are superimposed in the picture.
 Then, complete the setting of the time code character and title.

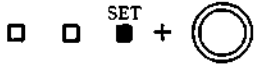
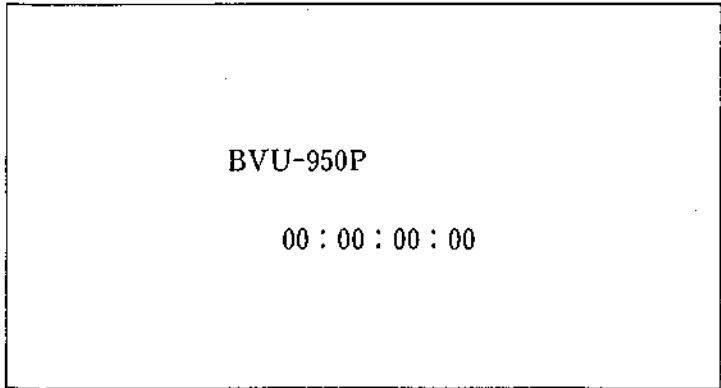

15. If press the SET button again or turn the dial, the setup picture will be displayed.
 This enable to set once again.

<Store and read-out the data>

16. In the case of the title and TCP, TLP store in the memory, move the cursor in the character menu area to the ST command and press the SET button on the Front Panel.
 In the case of the stored data display in the setup picture, move the cursor to the LD command and press the SET button.

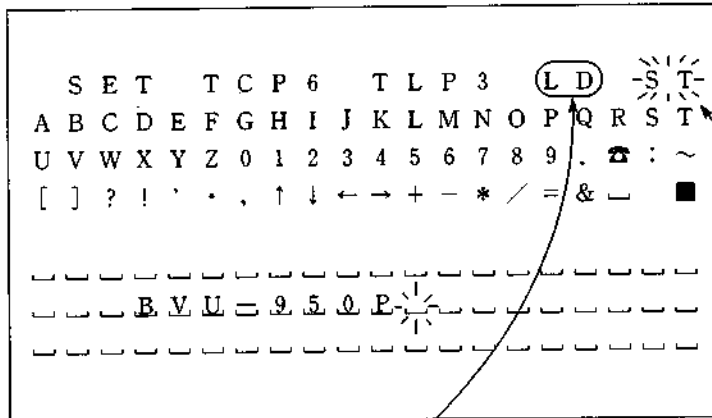

LD
 This read-out and display the stored data in the setup picture.

ST
 This store the title of the title setup area and TCP, TLP in the memory.
 These data are memorized in the memory even if the POWER switch is turned OFF. (The old data are cleared.)

- .When the data is stored once in the memory, these data can easily display on the setup picture by the following procedures.
1. Blink the LD command and press the SET button.
 2. Blink the SET command and press the SET button.

1111111111

(NOTE) 1. Setting of capital letters is performed by selecting the ITEM NO.104 TITLE (LARGE) in DIAL MENU.

The title setting and so on are the same procedures as above. However, TCP and TLP can set from 0 to 5 lines.

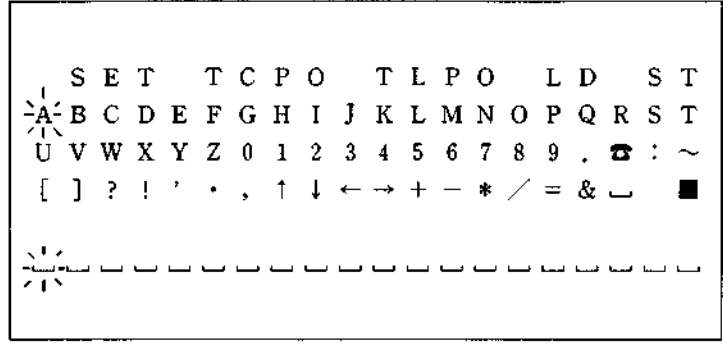

2. If the title characters and time code characters are set to the same position, the title characters have priority.

1-7-2. Insert the Characters on the Playback Picture

1. Set the CTL/TC/DIAL MENU switch to CTL or TC.

The time code character and the title set in sec. 1-7-1 are superimposed on the picture.

(NOTE) If the characters are not superimposed when the CTL/TC/DIAL MENU switch is set to CTL or TC, check that the CHARACTER switch on the Subcontrol Panel is set to ON.

2. Press the PLAY button.

1-7-3. Redording the Characters on the Tape

1. Set the CTL/TC/DIAL MENU switch to CTL or TC.

The time code character and the title set in sec. 1-7-1 are superimposed on the picture.

(NOTE) If the characters are not superimposed when the CTL/TC/DIAL MENU switch is set to CTL or TC, check that the CHARACTER switch on the Subcontrol Panel is set to ON.

2. Press the REC button and the PLAY button simultaneously.

3. In case of stopping the recoding partially, set the CHARACTER switch on the Subcontrol Panel to OFF while monitoring the picture.

The characters are not superimposed while the CHARACTER switch is set to OFF.

1-8. RACK MOUNTING

The BVU-950P can be rack-mounted in two ways.

(1) Rack-mounting of the BVU-950P in a console.

It is recommended that a RMM-501 Rack Mount Kit be used. This is an optional accessory which includes the Slide Rails and the Handle Brackets. If an RMM-501 is not available, use the following ACCURIDE slide rail:

RACK-MOUNT SLIDES MODEL 305
SLIDE LENGTH 20 INCH

1. Remove the Upper Case or Side Plate.
(Refer to Section 4-1)
2. Remove the two fixing screws on the Level Control Panel as shown in the figure.

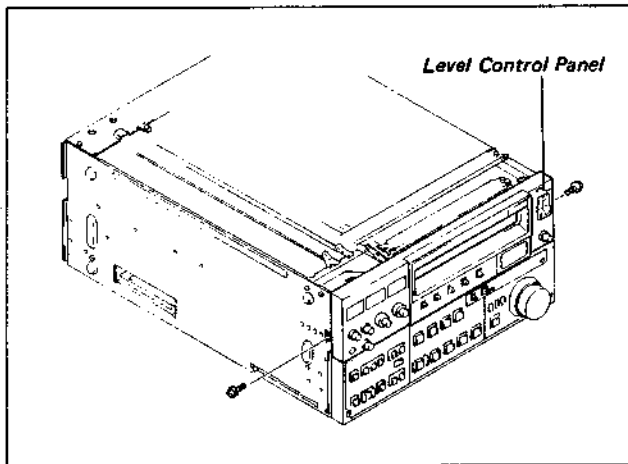

3. Remove the fixing screws (three each) on chassis (R) and chassis (L) as shown in the figure.

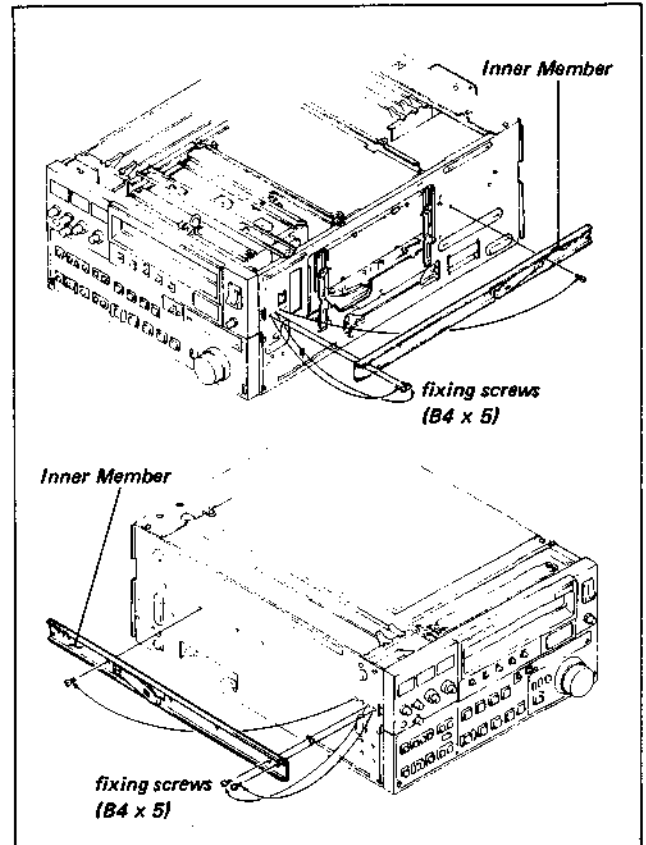

4. Attach the Inner Members of the Slide Rails to chassis (R) and chassis (L) with the screws removed in step 3.
 - . The installation screws must not be too long. If the screws supplied with the chassis are lost, screws 5 mm in length (B4 x 5) must be used.
 - . The Inner Member must be fastened at three points with the screws.

5. Remove the four legs located under the unit.
 - . If the unit is mounted in the console without removing the legs, they will hit the console and the unit cannot be pulled out.

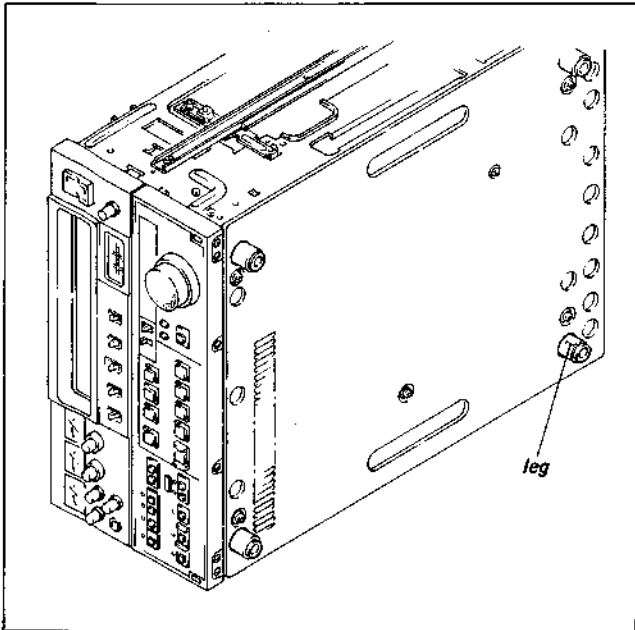

6. Attach the Outer Member Bracket of the Slide Rail to the console. Position the edge of the Slide Rail the specified distance from the outside of the console.
7. Attach the Handle Brackets.

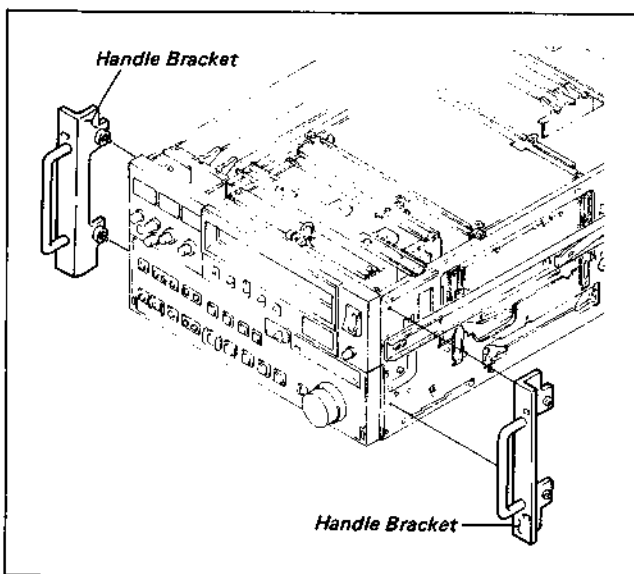

- (2) Rack-mounting of the BVU-950P on a 19-inch standard rack.

It is recommended that a RMM-950 Rack Mount Kit be used. This is an optional accessory which includes the Slide Rails, Handle Brackets and RMM-Brackets. If an RMM-950 is not available, use the following ACCURIDE slide rail:

RACK-MOUNT SLIDES MODEL 305
SLIDES LENGTH 22 INCH

1. Remove the Upper Case or Side Plate.
(Refer to Section 4-1)
2. Remove the fixing screws (three each) on chassis (R) and chassis (L) as shown in the figure.
3. Attach the Inner Members of the Slide Rails to chassis (R) and chassis (L) with the screws removed in Step 2.
 - . The installation screws must not be too long. If the screws supplied with the chassis are lost, screws 5 mm in length (B4 x 5) must be used.
 - . The Inner Member must be fastened at three points with the screws.

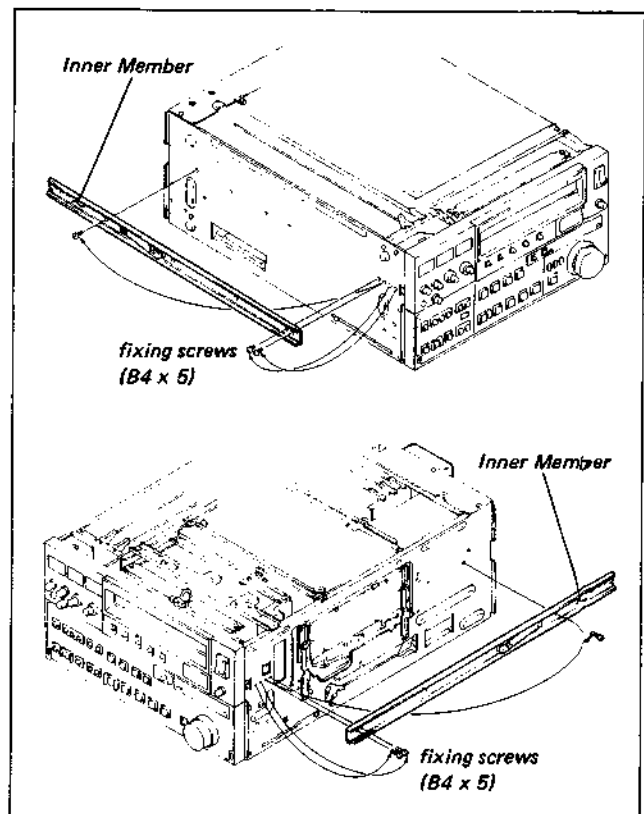

4. Remove the four the legs located under the unit.
 . If the unit is mounted in the rack without removing the legs, they will contact the lower unit, and the unit cannot be pulled out.
5. Remove the Bottom Plate and then attach it to the top of the unit with two fixing screws.
6. Attach the Outer Member Bracket of the Slide Rail to the rack. Position the edge of the Slide Rail specified distance from the outside of the rack.

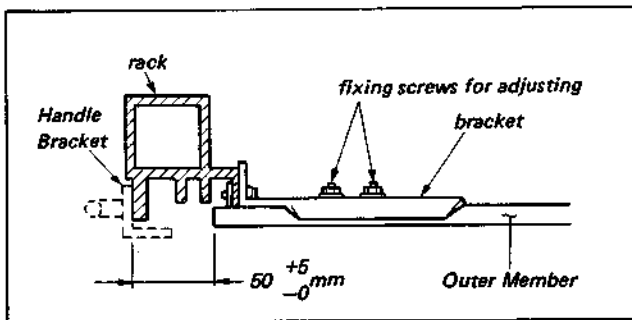

7. Thread the two fixing screws on the unit snugly, but do not tighten them. Install the RMM-Bracket as shown in the figure and then tighten the fixing screws. (When installing the RMM-Bracket on the right side of the unit, "R" on the RMM-Bracket is up. When installing the RMM-Bracket on the left side of the unit, "L" on the RMM-Bracket is up.)

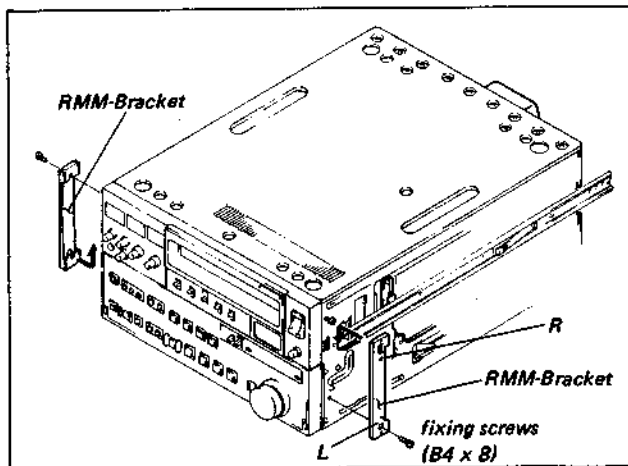

8. Attach the Handle Brackets.

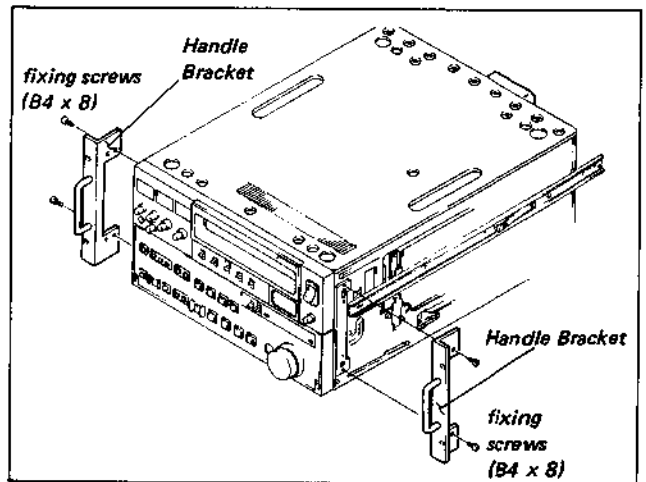

NOTE:

1. Seven BVU-950P units can be mounted on a 19-inch standard rack.
 When several units are mounted on the same rack, it is recommended that a fan is installed for ventilation. Good air circulation is essential to prevent internal heat build-up in the rack. The 5°C to 40°C environmental condition must be met for all units.
2. Be sure to secure the rack to the floor to avoid accidents when a BVU-950P is pulled out.

1-9. FUNCTION CONTROL PANEL POSITIONING

Raise the Function Control Panel while pushing down on the left and right knobs on the front of the panel.

To replace the Function Control Panel, push the Function Control Panel down to its original position while lifting the left and right arms.

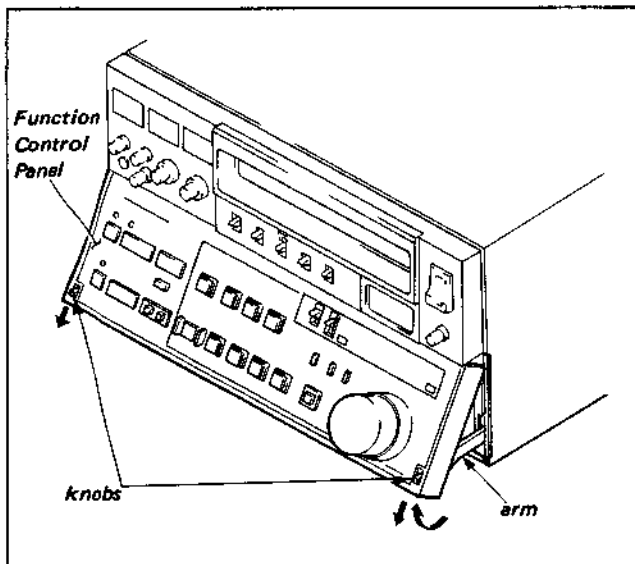

1-10. USE OF THE FUNCTION CONTROL PANEL AS A REMOTE CONTROL UNIT

When the Function Control Panel Unit is removed from the unit to be used for remote control, perform the following steps.

1. Remove the Function Control Panel. (Refer to Section 4-2)
2. Remove the three fixing screws and remove Sub-control Panel.

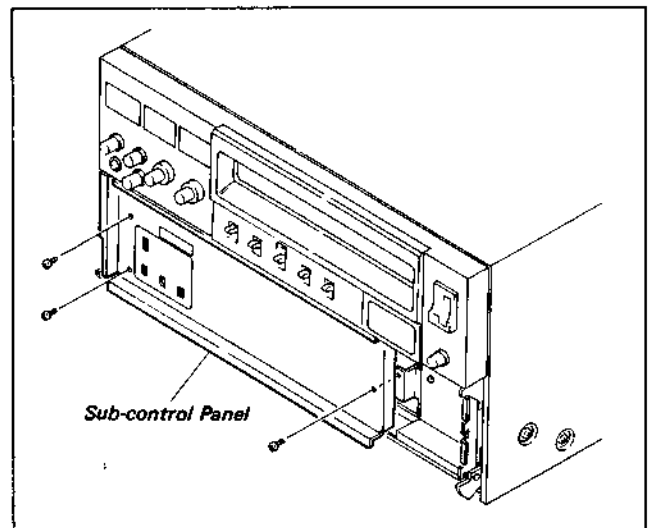

(Extraction of the cable from the front of the unit)

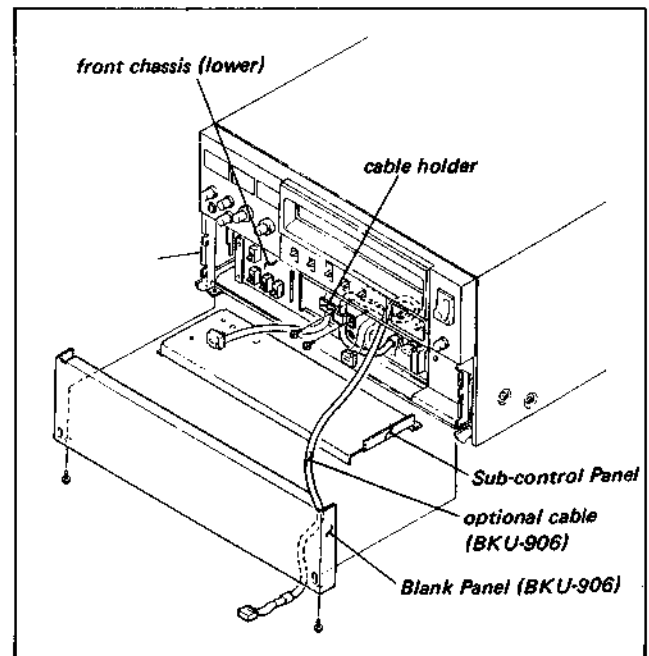

3. Disconnect the Flat Cable on the SY-102A Board, and then connect the optional Cable (5 m), BKU-906.
4. Loosen the fixing screw of the cable holder, slide the cable under the cable holder, and tighten the fixing screw.
5. Extract the cable from the notch in the top of the Front Chassis (lower) and attach Sub-control Panel with the three fixing screws.
6. Replace the Function Control Panel with the optional Blank Panel BKU-906. Pass the cable through the notch in the Blank Panel and attach it to the unit.

(Extraction of the cable from the rear of the unit)

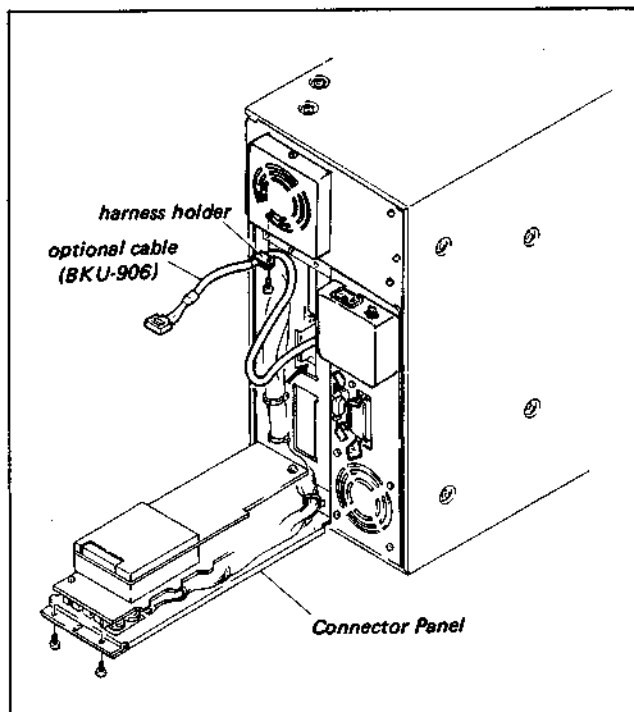

3. Set the unit on its left side, remove the two fixing screws and open the Connector Panel.
4. Insert the optional cable (5 m), BKU-906 in the unit from the rear. Position the cable along the wiring harness.
5. Disconnect the Flat Cable on the SY-102A Board and connect the optional cable.

6. Set the unit on its bottom and loosen the fixing screw of the Harness Holder as shown in the figure. Insert the cable in the harness holder and tighten the fixing screw.
7. Pass the cable through the corner at the lower left-end of the Connector Panel and attach the Connector Panel.
8. Attach the Sub-control Panel with the three fixing screws.
9. Attach the optional Blank Panel, BKU-906.

1-11. REMOTE 2 (24P) CONNECTOR

The REMOTE 2 (24P) connector is used for system expansion, depending on the way the unit is used. The signal at each pin is listed in Section 1-3. Since the remote cable is not provided as an optional accessory, prepare the cable according to the REMOTE 2 pin listing. The part number for the cable connector is listed in Section 1-4. The remote cable can be a maximum of 10 m.

1-12. SUPPLIED ACCESSORIES

Supplied BVU-950P accessories are as follows:

1. AC Power Cord
2. Dubbing Cable (VDC-5)

This cable is used for tape to tape editing and dubbing through the dubbing connector.
(length: 5 m)

Only the video signal passes through this cable. Different cables are required for audio signals. Cables should never be connected between units as illustrated in the figure.

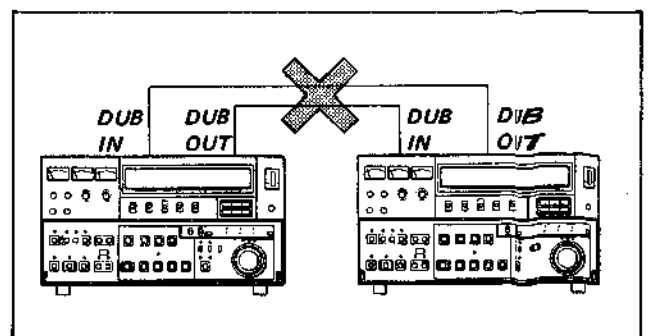

3. 9-Pin Remote Control Cable (RCC-5G)

This cable is used for remote control from one BVU-950P as a recorder to the other BVU-950P as a player when the two units are used for tape to tape editing and dubbing.

4. Extension Boards (EX-127, EX-128)

The BVU-950P main circuit boards are the plug-in type which are easy to remove and install. Extension Boards are used for alignment and maintenance of the plug-in boards.

Two kinds of the Extension Boards are provided. Suitable Extension Board is used for alignment and maintenance of the main board. (Refer to Section 4-6)

1-13. OPTIONAL ACCESSORIES

The following optional accessories are available.

The appropriate accessories should be used for each system.

1. Plug-in Time Base Corrector (BKU-903)

The TBC Board (TBC-6 Board) easily plugs into the BVU-950P.

The BKU-903 can be controlled by the BVR-50P Remote Control Unit (supplied) through the TBC Remote Connector. This provides a stable playback picture.

2. Plug-in Time Code Generator/Reader (BKU-905)

The BKU-905 enables the recording and reading of SMPTE LTC and user bits on the address track of the tape. The BKU-905 consists of a plug-in TC Board (TC-42) and Time Code Control Panel.

3. Control Panel Extension Kit (BKU-906)

The BKU-906 Blank Panel is a bracket which covers the exposed section of the BVU-950P when the Control Panel is removed.

The BKU-906 contains a Cord Retainer and 10-pin Remote Control Cable (5 m) to connect between the VTR and the Control Panel.

4. Control Panel Case (BK-803)

The BK-803 is a Control Panel Case to house the Remote Control Panel when it is removed from the BVU-950P.

5. Rack Mount Kit for the Sony System Console (RMM-501)

The RMM-501 is used for mounting the BVU-950P on the Sony System Console.

It consists of two Slide Rails and two Handle Brackets.

6. Rack Mount Kit for a 19-inch standard rack (RMM-950)

The RMM-950 is used for mounting the BVU-950P on a 19-inch standard rack.

It consists of two Slide Rails, two RMM-Brackets and two Handle Brackets.

7. 9-pin Remote Control Cable

Three kinds of 9-Pin Remote Control Cables are provided.

Type	Length
RCC-5G:	5 m
RCC-10G:	10 m
RCC-30G:	30 m

These Remote Cables are used for connecting to another BVU-950P through the 9-Pin Remote Connector.

The remote cable can be a maximum of 1200 m.

SECTION 2 TECHNICAL INFORMATION

2-1. SPECIFICATIONS

MECHANICAL

Weight : 28 Kg
 Dimensions : 424 x 237 x 590 mm (w/h/d)
 Operating position : Vertical (less than 30°)
 Tape transport mechanism : U-matic system
 Video cassette : U-matic KSP, KSP-S, KCA, KCS video cassettes or equivalent
 Tape speed : 9.53 cm/s
 Record/playback time : 60 min. max. with KSP-60 video cassette
 Wow/flutter : 0.18% (DIN)
 Fast forward time: : Less than 3 min. with KSP-60 video cassette
 Rewind time : Less than 2.5 min. with KSP-60 video cassette
 Search speed : SHUTTLE:
 Still, 1/30, 1/10, 1/5, 1/2, 1, 2, 5, and 10 times normal in forward and reverse direction
 JOG:
 Still to 1 time normal in forward and reverse direction
 Operating temperature : +5° C to +40° C
 Storage temperature : -20° C to +60° C

CONNECTORS:

AC IN : 3-pin AC connector
 VIDEO IN : BNC connectors (2)
 VIDEO OUT : BNC connectors (2)
 AUDIO IN CH-1/L, CH-2/R : XLR female connectors
 AUDIO OUT CH-1/L, CH-2/R : XLR male connectors

AUDIO OUT MONITOR

: XLR male connector
 TIME CODE IN : BNC connector
 TIME CODE OUT : BNC connector
 DUB IN : 7-pin male connector
 DUB OUT : 7-pin female connector
 REF VIDEO IN (EXT SYNC IN) : BNC connectors (2)
 REF VIDEO OUT : BNC connector
 RF (OFF TAPE) : BNC connector
 TBC REMOTE : 15-pin connector
 MONITOR : 8-pin connector and BNC connector
 REMOTE 1 : RS-422 9-pin connector
 REMOTE 2 : 24-pin connector
 HEADPHONES : JM-60 stereo phone jack

ELECTRICAL

Power requirements : AC 90 to 264V
 48 to 64 Hz
 Power consumption : 160 W

VIDEO

Video recording system : Luminance: FM
 Chroma: SC low-range conversion
 Input : PAL composite video, sync negative, 1.0 ± 0.3 Vp-p, 75 Ohms, unbalanced
 Output : PAL composite video, sync negative, 1.0 ± 0.2 Vp-p, 75 Ohms, unbalanced
 Dubbing input : Luminance signal: 0.5 ± 0.2 Vp-p, sync negative, impedance 75 Ohms ± 10%
 Chroma signal: 0.5 ± 0.1 Vp-p, impedance 75 Ohms ± 10%

Dubbing output : Luminance signal:
 0.5 ± 0.2 Vp-p,
 sync negative,
 impedance 75 Ohms ± 10%
 Chroma signal:
 0.5 ± 0.1 Vp-p,
 impedance 75 Ohms ± 10%

Horizontal resolution
 : SP mode: 300 lines
 (monochrome/color mode)
 Conventional mode: 260 lines
 (monochrome/color mode)

Signal to noise ratio
 : SP mode:
 Color mode: More than 46 dB
 Luminance(Y): More than 49 dB
 Conventional mode:
 Color mode: More than 46 dB

K-factor (2T pulse)
 : Less than 3% (SP mode)
 DG
 : Less than 3% (SP mode)
 DP
 : Less than 3° (SP mode)
 Y/C delay
 : Less than 25 ns (SP mode)

AUDIO

Input : (LOW) -60 dB, 3 k Ohms, balanced
 (matches 600 Ohm microphones)
 (HIGH) +4 dB, 10 k Ohms/600 Ohms,
 balanced
 Output : (LINE) +4 dBm, balanced
 (600 Ohm load permissible)
 (MONITOR) +4 dBm, 600 Ohm load,
 balanced
 (HEADPHONES) -46 dB to -26 dB,
 8 Ohm load, stereo

Distortion : Less than 2.0% (1 kHz reference level)

Frequency response
 : SP mode: 50 Hz to 15 kHz ± 3 dB
 Conventional mode:
 50 Hz to 15 kHz ± 4 dB

Signal to noise ratio
 : SP mode: More than 52 dB (at 3% distortion level, without audio NR system)
 Conventional mode:
 50 dB (at 3% distortion level)

TIME CODE

Input : 0 ± 6 dB, 10 k Ohms, unbalanced
 (0 dB = 1.55 Vp-p pulse)
 Output : 0 ± 3 dB, low impedance, unbalanced
 (0 dB = 1.55 Vp-p pulse)

REF VIDEO

Input : 1.0 ± 0.2 Vp-p, 75 Ohms, unbalanced
 (EXT SYNC IN : 0.2 Vp-p to 5 Vp-p, negative, 75 Ohms, unbalanced)
 Output : Without the TBC Board:
 No output
 With the TBC Board and an input signal at REF VIDEO IN:
 Same level as REF VIDEO IN (1.0 ± 0.2 Vp-p), 75 Ohms, unbalanced
 With the TBC Board, but without an input signal at REF VIDEO IN:
 B.S. (0.3 Vp-p/0.3 Vp-p), 75 Ohms, unbalanced

RF (OFF TAPE)

Output : 0.5 Vp-p, 75 Ohms, unbalanced

2-2. LOCATION OF MAIN PARTS

2-2-1. Location of the Mechanical Main Parts/Components

<TOP VIEW>

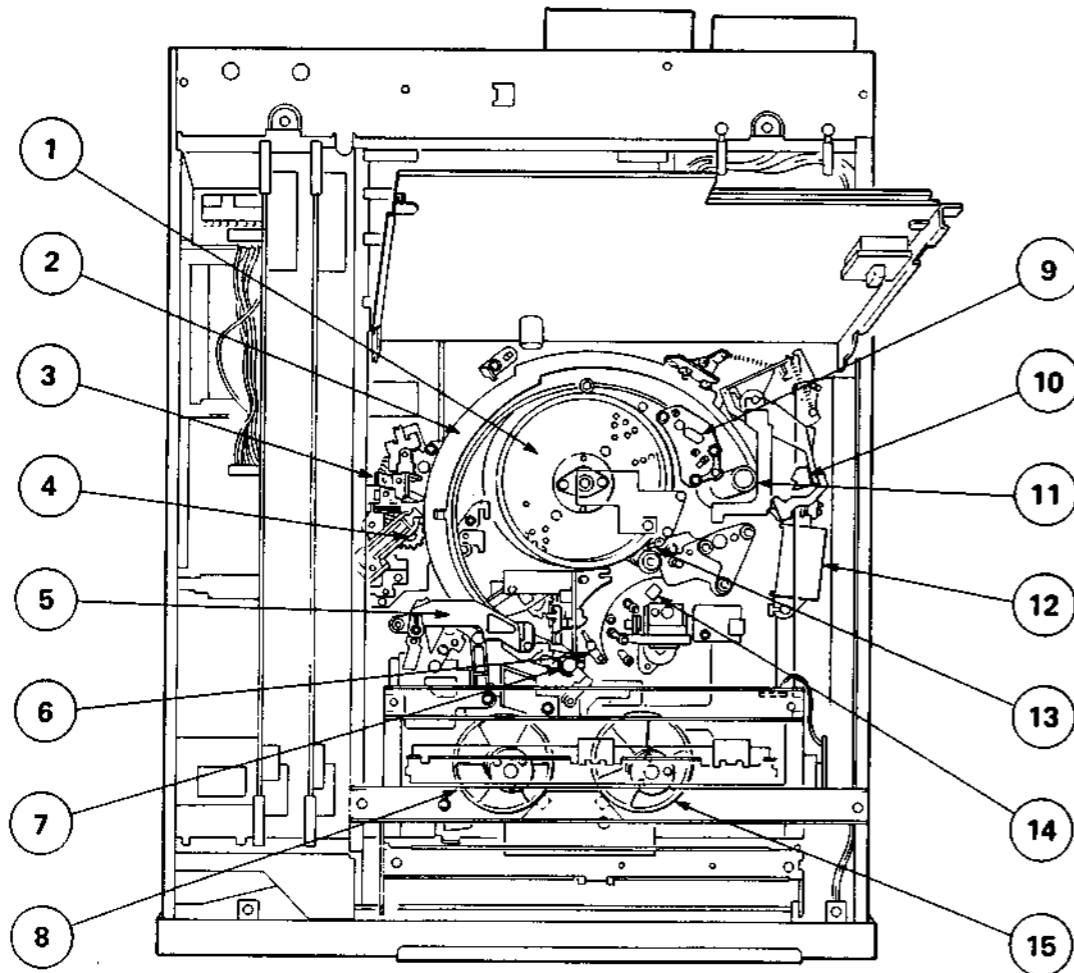

- | | |
|----------------------|---------------------|
| ① Drum | ⑨ Audio/CTL Head |
| ② Threading Ring | ⑩ Pinch Lever |
| ③ T Correction Guide | ⑪ Capstan Shaft |
| ④ Gear Box | ⑫ Pinch Solenoid |
| ⑤ T Drawer Arm | ⑬ Time Code Head |
| ⑥ S Drawer Arm | ⑭ Erase Head |
| ⑦ Pinch Roller | ⑮ Supply Reel Table |
| ⑧ Take-up Reel Table | |

<BOTTOM VIEW>

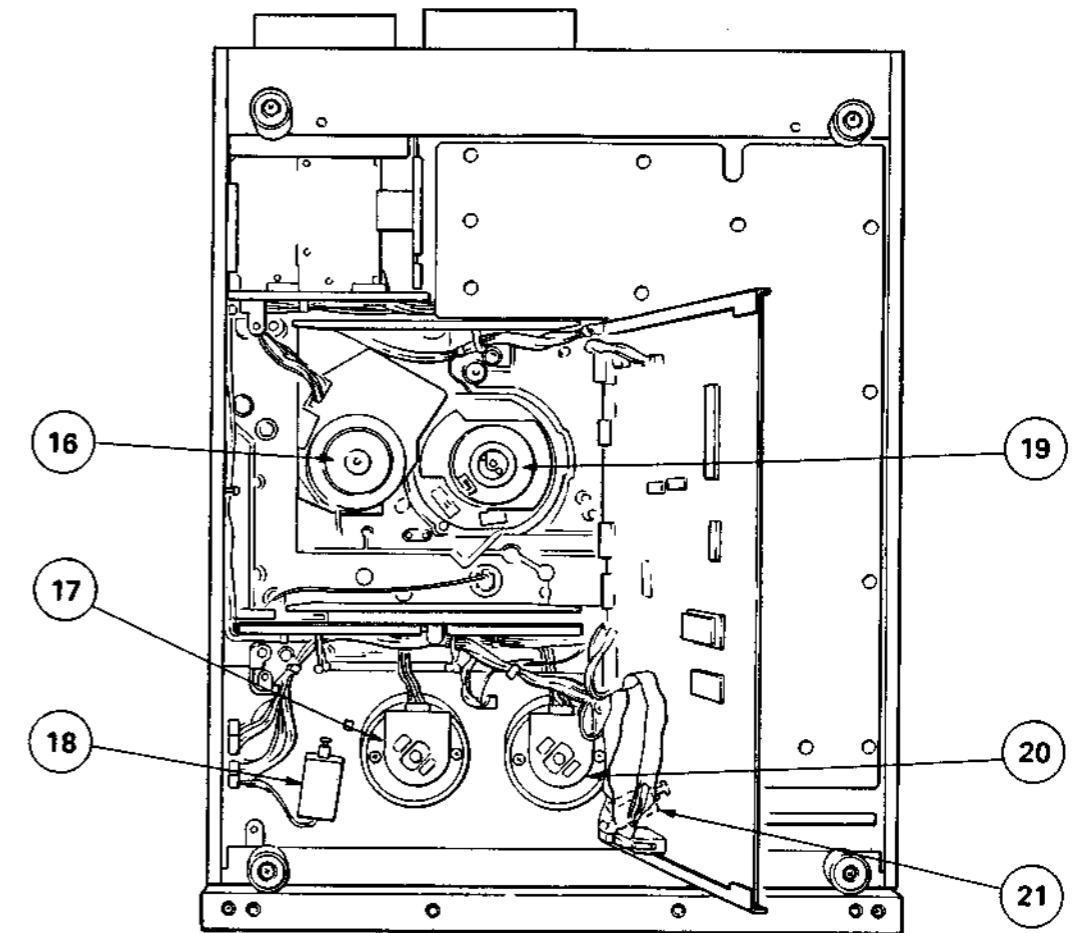

- | |
|-------------------------------|
| ⑯ Capstan Motor |
| ⑰ S Reel Motor |
| ⑱ Supply Reel Brake Solenoid |
| ⑲ Drum |
| ⑳ T Reel Motor |
| ㉑ Take-up Reel Brake Solenoid |

<SENSOR BLOCK>

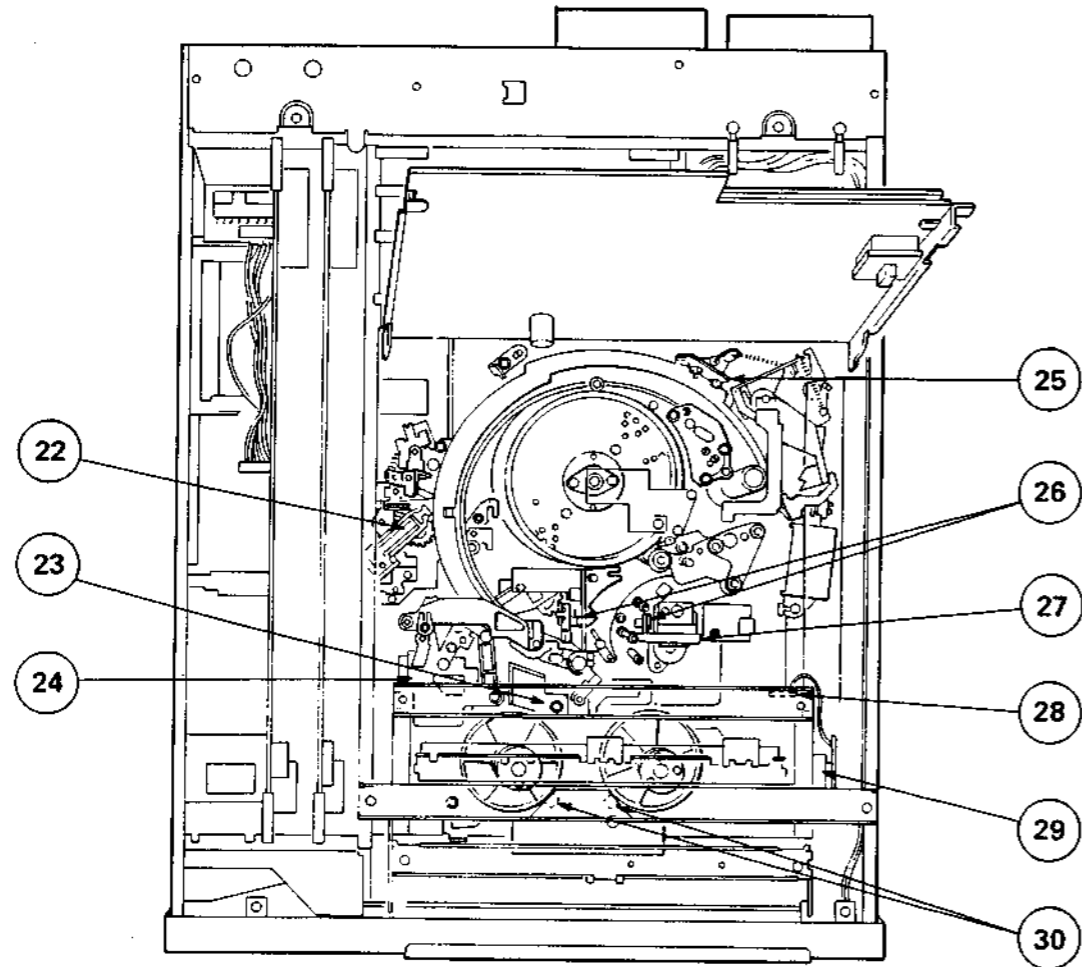

- ②② Tape Beginning sensor
- ②③ Take-up Side Tension Detector
- ②④ TRC Detector
- ②⑤ FR Detector
- ②⑥ Tape End Sensor
- ②⑦ Supply Side Tension Detector
- ②⑧ Cassette-in Detector
- ②⑨ Cassette-down Detector
- ③⑩ Reel Rotation Detector

2-2-2. Location of the Printed Circuit Boards

TOP VIEW >

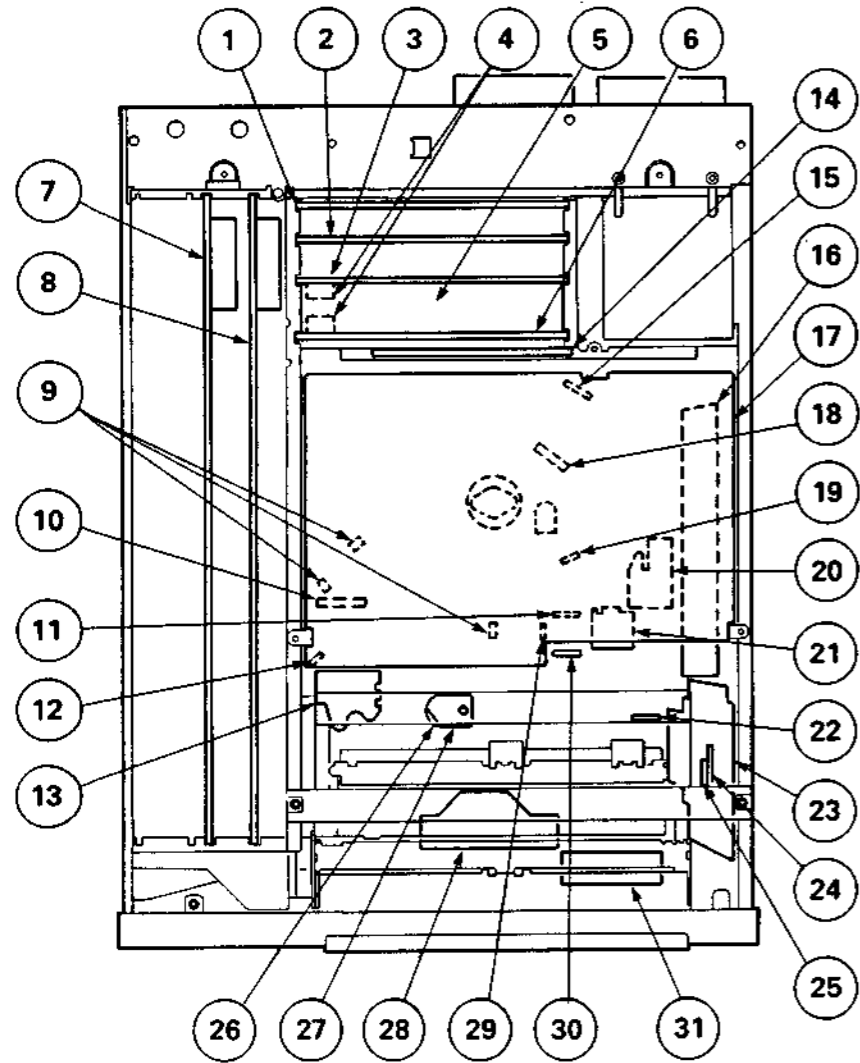

- | | | |
|-----------------------|-----------------|-----------------------|
| ① AU-85A Board | ⑪ LE-53 Board | ⑳ HN-83 Board |
| ② BC-11 Board | ⑫ PTC-34 Board | ㉑ CC-33 / CC-37 Board |
| ③ AU-84A Board | ⑬ PTC-30 Board | ㉒ PD-37 Board |
| ④ DUS-71 Board | ⑭ HN-80 Board | ㉓ CC-31 / CC-36 Board |
| ⑤ HN-77 Board | ⑮ PTC-33 Board | ㉔ CC-32 / CC-38 Board |
| ⑥ AU-83A Board | ⑯ RP-30A Board | ㉕ LE-54 Board |
| ⑦ DM-55 Board | ⑰ MD-45 Board | ㉖ PTC-29 Board |
| ⑧ SV-88A/SV-113 Board | ⑱ DUS-92 Board | ㉗ SE-48 Board |
| ⑨ PH-5 Board | ⑲ HN-84 Board | ㉘ PTC-26 Board |
| ⑩ LM-13 Board | ⑳ DUS-147 Board | ㉙ PTC-28 Board |
| | | ㉚ LP-41 Board |

<BOTTOM VIEW>

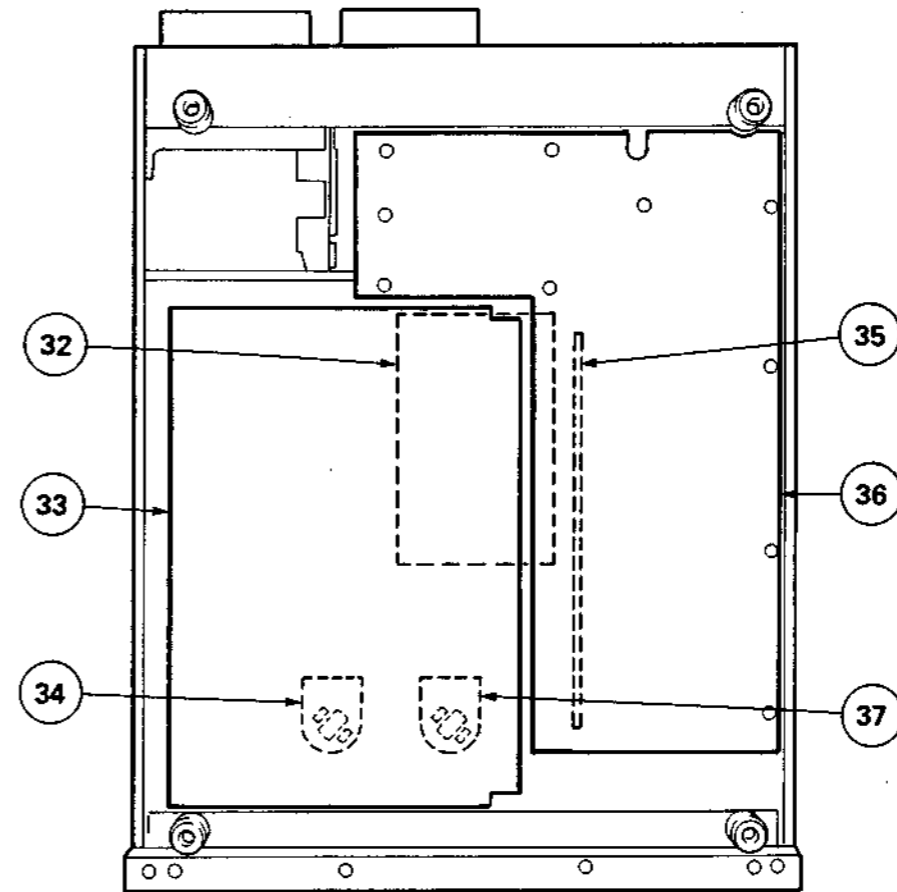

- | |
|-----------------|
| ㉛ DSC-44 Board |
| ㉜ SY-102A Board |
| ㉝ DUS-178 Board |
| ㉞ MB-139 Board |
| ㉟ MB-127 Board |
| ㊱ DUS-177 Board |

<FRONT VIEW>

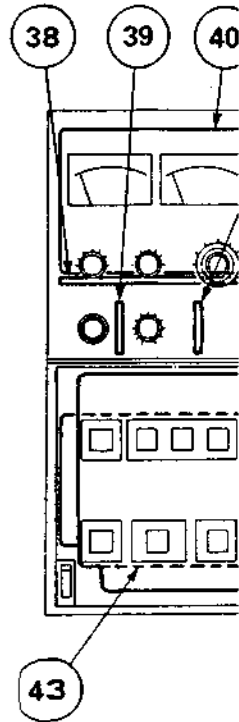

43

< FRONT VIEW >

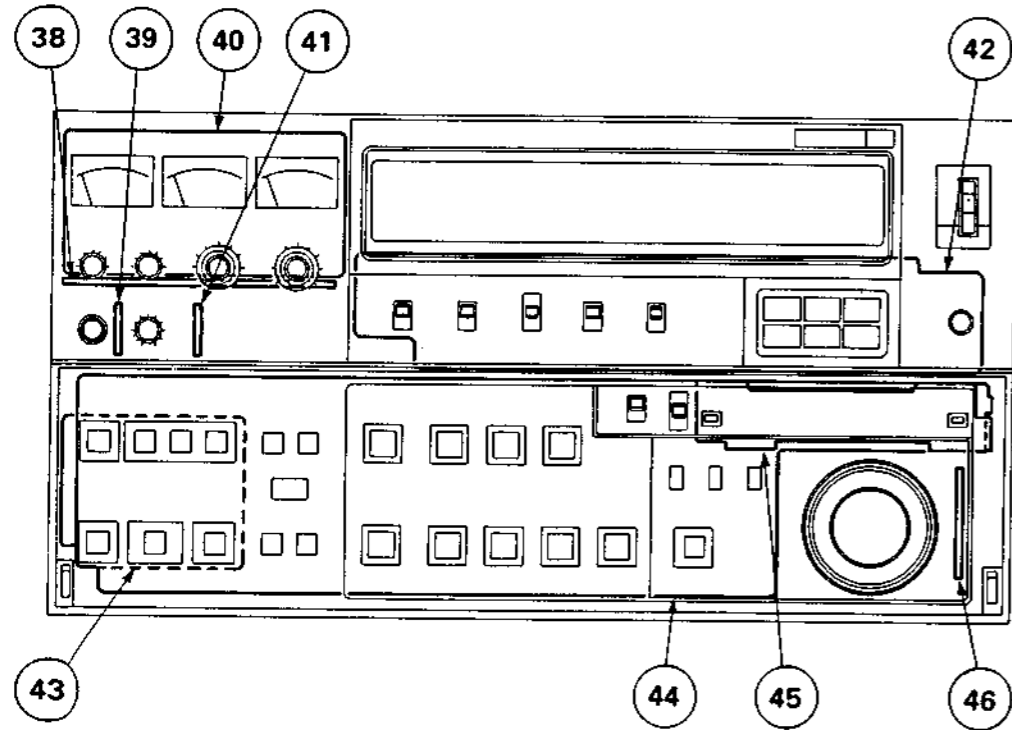

- ③⑧ VR-48 Board
- ③⑨ HP-28 Board
- ④⑩ MT-28 Board
- ④① VR-49 Board
- ④② SW-170 Board
- ④③ SW-171 Board
- ④④ KY-101 / KY-144 Board
- ④⑤ DP-62 Board
- ④⑥ PTC-32 Board

< REAR VIEW >

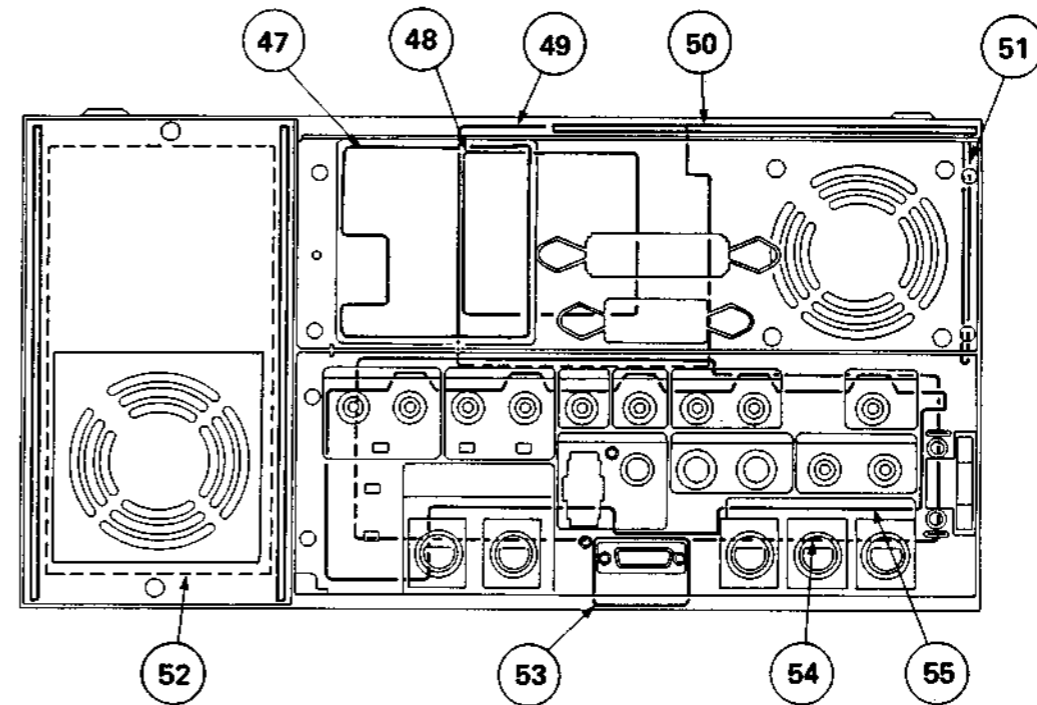

- ④⑦ AC-79 Board
- ④⑧ RM-44 Board
- ④⑨ AC-78A Board
- ⑤⑩ DR-53 Board
- ⑤① DR-59 Board
- ⑤② Switching Regulator (UR-21)
- ⑤③ RM-45 Board
- ⑤④ AU-87 Board
- ⑤⑤ CP-109 Board

2-3. PRINTED CIRCUIT BOARDS

Circuit information is provided below.

SYSTEM	CIRCUIT BOARD	CIRCUIT FUNCTION
VIDEO	RP-30A	RF REC/PB /rotary erase
	MD-45	Y/C modulator
	DM-55	Y/C demodulator
	SW-170	Video level MANU/AUTO select
	VR-48	Video level control
	MT-28	Video level meter
AUDIO	AU-83A	CH-1 REC/PB /DOLBY processor
	DUS-71	Variable coil
	AU-84A	CH-2 REC/PB
	DUS-71	Variable coil
	HN-77	Junction board
	AU-85A	DOLBY auto detector, bias oscillator
	SW-171	DOLBY ON/OFF switch
	AU-87	Mic/output/monitor amplifier
	VR-48	REC/PB level control
	MT-28	Audio level meter
	VR-49	Headphones level control
	HP-28	Headphones
	DUS-92	Audio head
	DUS-147	Junction board for audio head
	BC-11	Full erase oscillator
SW-170	Audio monitor select	
SERVO	SV-88A/SV-113	Drum/capstan/reel servo
	SE-48	Reel rotation detector
	DR-53	Motor driver for reel/capstan/drum
	DR-59	Motor driver for reel
	PTC-28	S-tension CDS
	LE-53	S-tension LED
	PTC-29	T-tension CDS
	LE-54	T-tension LED
	DUS-177	T-reel motor
	DUS-178	S-reel motor
	VR-48	Tracking control

SYSTEM	CIRCUIT BOARD	CIRCUIT FUNCTION
SYSCON	SY-102A	System control
	KY-101 / KY-144	Function key board
	DP-62	Display
	BC-11	Video/audio timing control
	HN-80	Threading motor driver
	LM-13	Threading motor
	PD-37	Cassette-up compartment motor driver /Solenoid driver
	CC-31 / CC-36	Cassette compartment driver
	CC-32 / CC-36	Cassette down detector
	CC-33 / CC-37	Cassette in detector
	PTC-30	SP, miss REC. KCA detector
	PTC-33	FR stop detector
	PTC-34	Uthread end detector
	PH-5(A)	Tape top LED
	PH-5(B)	Tape top sensor
	PH-5(C)	Tape end LED
	PTC-26	Tape end sensor
	SW-170	Select switch /warning indicator
	SW-171	Remote 1/2 Select /TBC ON/OFF /Character ON/OFF
	PTC-32	Search dial
RM-44	Remote control (9pin & 24pin)	
DSC-44	Character generator	
TIME CODE	TC-42	Time code (Option)
	BC-11	Time code REC/PB amplifier
	HN-84	Time code head
	SW-172	Time code control Switch (Option)
POWER	AC-78A	AC primary circuit
	AC-79	Line filter
	M1	Switching Regulator (UR-21)
	M2	
	C1	
	C2	
OTHERS	MB-127	Mother board
	MB-139	Sub mother for TC
	CP-109	Connector panel
	RM-45	TBC remote control
	EX-127	Extension board for Audio/Time code
	EX-128	Extension board for Video/Servo/TBC
	HN-80	Relay board for video/tape sensor/ threading motor driver
	HN-83	Relay board for time code head/erase head
	MT-28	Meter
	LP-41	Cassette compartment light
	TBC-6	Time base corrector (Option)

2-4. CASSETTE REMOVAL PROCEDURE WHEN NORMAL EJECTION IS NOT POSSIBLE

If the EJECT operation becomes impossible due to trouble or the Cassette-up Compartment does not rise when the EJECT operation takes place, the cassette tape can be removed from the unit by following the procedures described below.

1. Turn the POWER OFF.
2. Remove the Upper Case or Top Plate.
(Refer to Section 4-1)
3. Remove the SV-88A/SV-113 and DM-55
(and TBC-6) Boards.
4. Turn the white pulley of the Gear Box by hand in a clockwise direction until the Threading Ring is in the unthread end position. (The Threading Ring moves in the unthreading direction. However, the tape remains at the position of threading completion.)

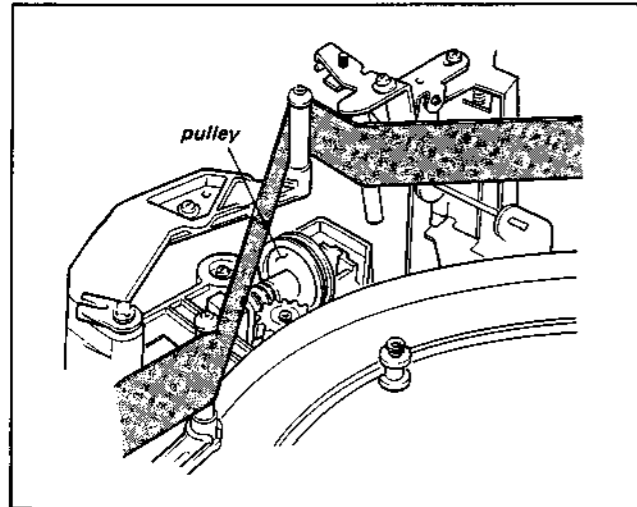

5. Disconnect the connector CN1 on the CC-31 /CC-36 Board of the Cassette-up Compartment.
6. Remove the Cassette-up Compartment Stay.
(Refer to Section 4-3)
7. Slowly lift the Cassette-up Compartment with the cassette tape in it. Remove the tape remaining in the unit carefully so that it is not damaged.
8. Hold the Cassette Tape Lid so that it does not close. Wind the tape into the cassette by turning the reel hub on the bottom of the cassette by hand.

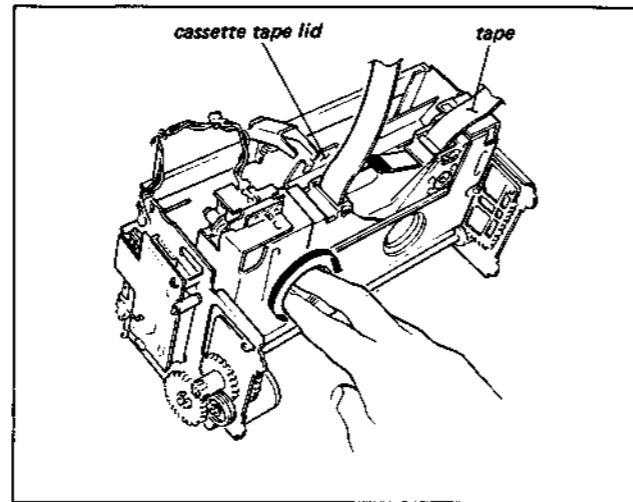

9. Raise the Cam for opening the lid and close the Cassette Tape Lid.

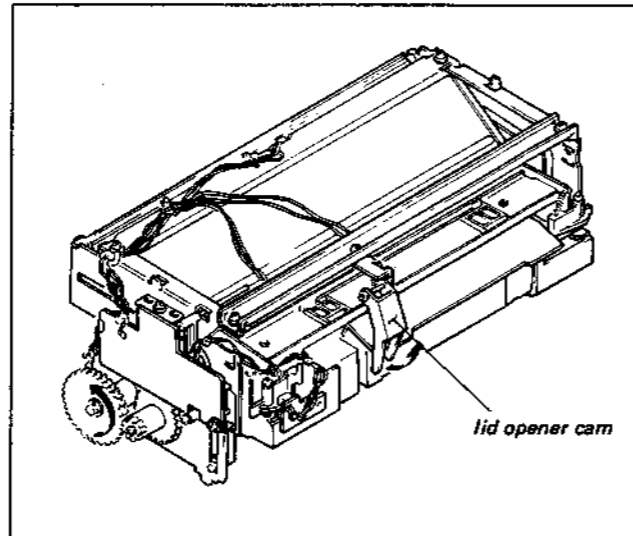

10. Remove the tape from the Cassette-up Compartment.
11. Turn the white gear on the right side of the Cassette-up Compartment by hand in a counterclockwise direction in order to place the Cassette-up Compartment into the up-state.
12. Locate the cause of the trouble and remedy the problem.

2-5. THE TAPE SPEED AND TIME IN FF AND REW MODE

1. KCA-60 (When the cassette tape is inserted at tape top, and the first time operation. Do not speed down at the tape middle after FF or REW operation is performed once.)

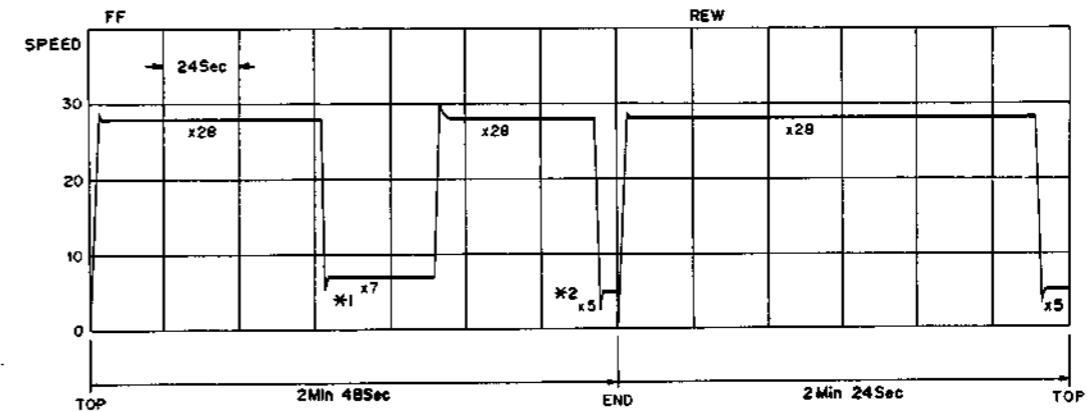

- *1 Detect the reel hub diameter. (The tape runs at seven times normal speed when S reel hub diameter is near the hub of large hub cassette.)
- *2 The tape runs at five times normal speed when the tape is near end.

2. KCA-60 (When the supply reel hub diameter is smaller than large hub once.)

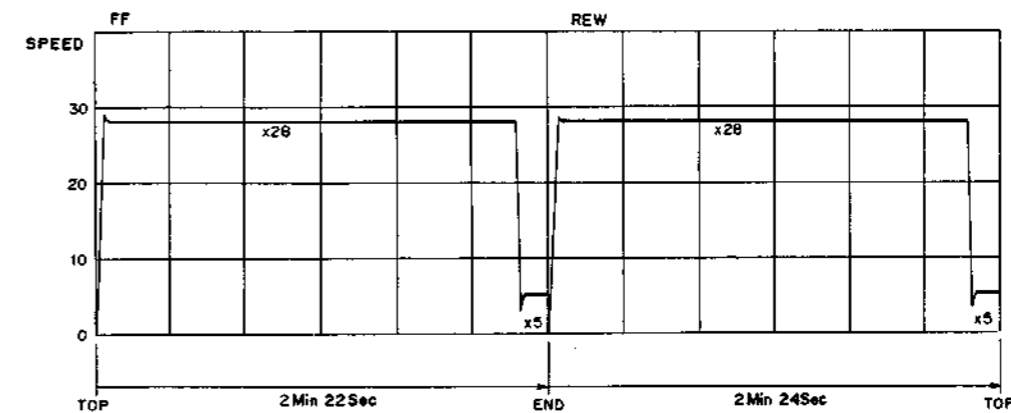

3. KCA-30 (Supply reel is large diameter hub.)

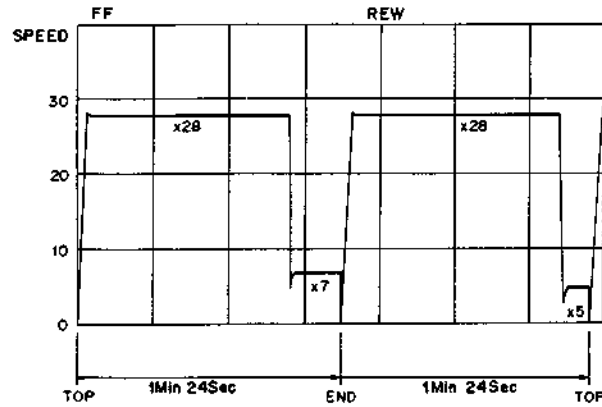

4. KCS-20

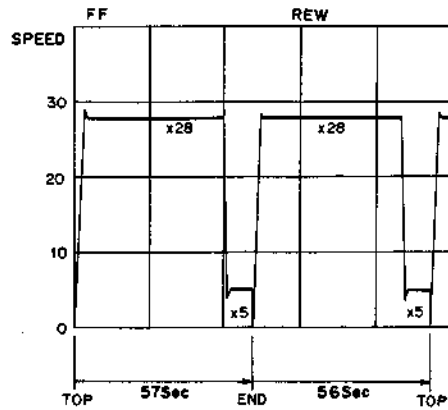

When the KCS-20 cassette tape is inserted at the middle of the tape, the tape runs at 7 times normal speed in FF and REW modes until T reel or S reel hub diameter is smaller than a large hub.

5. KCS-10 (Both Take-up reel and Supply reel are large hub.)

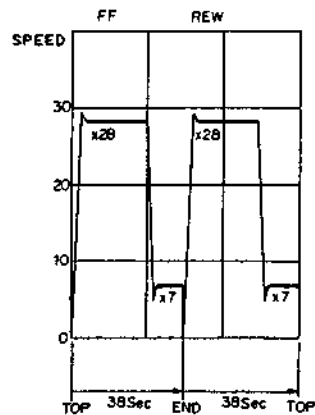

(NOTE) 1. When the unit is in TBC ON mode and the PB.PB/EE switch is set to PB, the tape runs at 22 times normal speed in FF mode. Therefore the fast forward time takes time.

2. The above figures are standard time.

2-6. TIMING CHART

※1 CASSETTE IN/CASSETTE DOWN

CASSETTE IN	CASSETTE DOWN	CASSETTE POSITION
L	L	During CASSETTE-IN
L	H	CASSETTE-UP State
H	L	During CASSETTE-DOWN
H	H	CASSETTE-DOWN State

※2 THREAD END1/THREAD END2

THREAD END1	THREAD END2	THREADING RING POSITION
H	H	Between CASSETTE-IN and FR-STOP
L	H	THREAD END position
L	L	Between FR-STOP and THREAD END
H	L	FR-STOP position

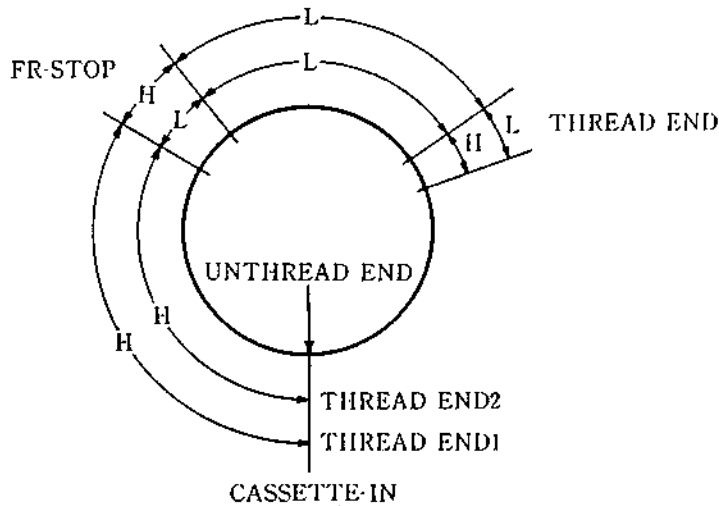

※3 THREADING MOTOR(+): H
 THREADING MOTOR(-): L } → THREADING OPERATION
 THREADING MOTOR(+): L
 THREADING MOTOR(-): H } → UNTHREADING OPERATION

※4 CASSETTE COM. MOTOR(+): L
 CASSETTE COM. MOTOR(-): H } → CASSETTE DOWN OPERATION
 CASSETTE COM. MOTOR(+): H
 CASSETTE COM. MOTOR(-): L } → CASSETTE UP OPERATION

1. CASSETTE IN → THREADING → STOP

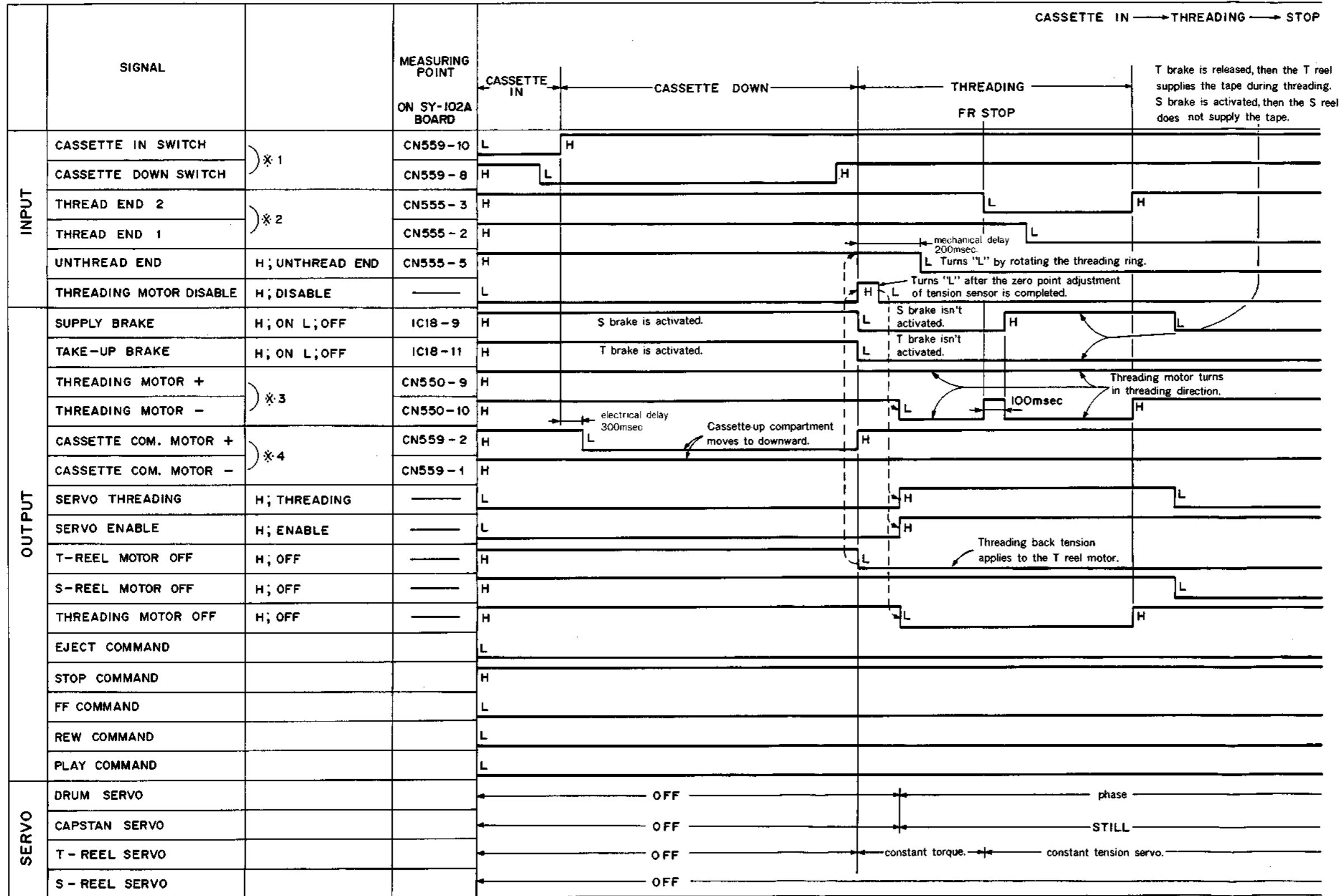

2. STOP → UNTHREADING → CASSETTE UP

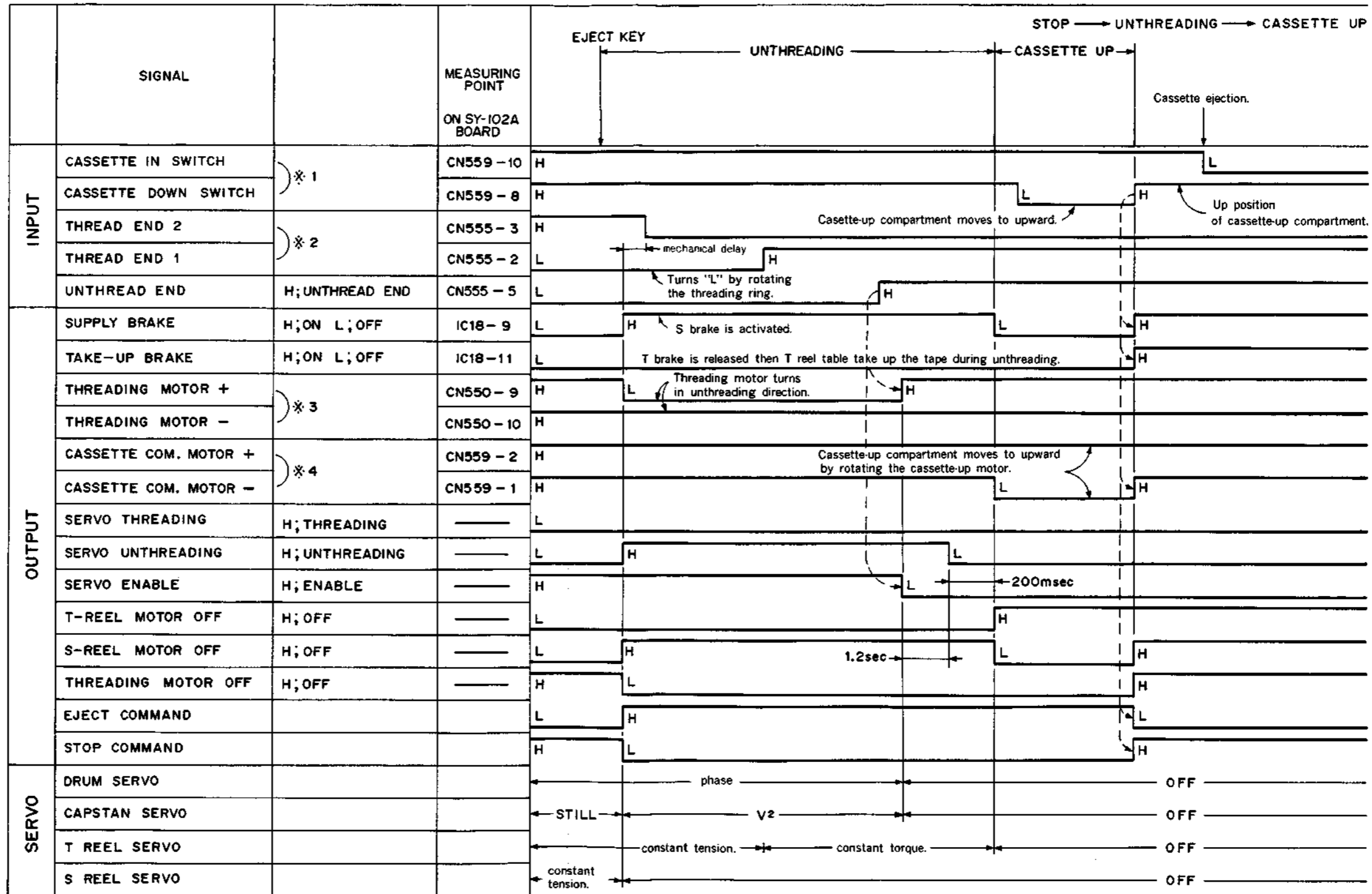

3. STOP → PLAY → STOP

				STOP → PLAY → STOP	
	SIGNAL		MEASURING POINT ON SY-102A BOARD	PLAY KEY	STOP KEY
IN-PUT	PINCH ON/OFF DISABLE	H; DISABLE	---	L	
	SUPPLY BRAKE	H; ON L; OFF	IC18-9	L	
	TAKE-UP BRAKE	H; ON L; OFF	IC18-11	L	
	L: PINCH ON	L; ON	TP9	L	
	SERVO ENABLE	H; ENABLE	---	H	
	CAPSTAN FWD	H; FWD L; REV	---	H	
	T-REEL MOTOR OFF	H; OFF	---	L	
	S-REEL MOTOR OFF	H; OFF	---	L	
	EJECT COMMAND			L	
	STOP COMMAND			H	L
	FF COMMAND			L	
	REW COMMAND			L	
	PLAY COMMAND			L	H
	SEARCH COMMAND			L	
SERVO	DRUM SERVO			phase	
	CAPSTAN SERVO			← STILL →	← INSTANT START →
	REEL SERVO			Phase (PB CTL)	
				constant tension.	

4. STOP → FF/REW → STOP

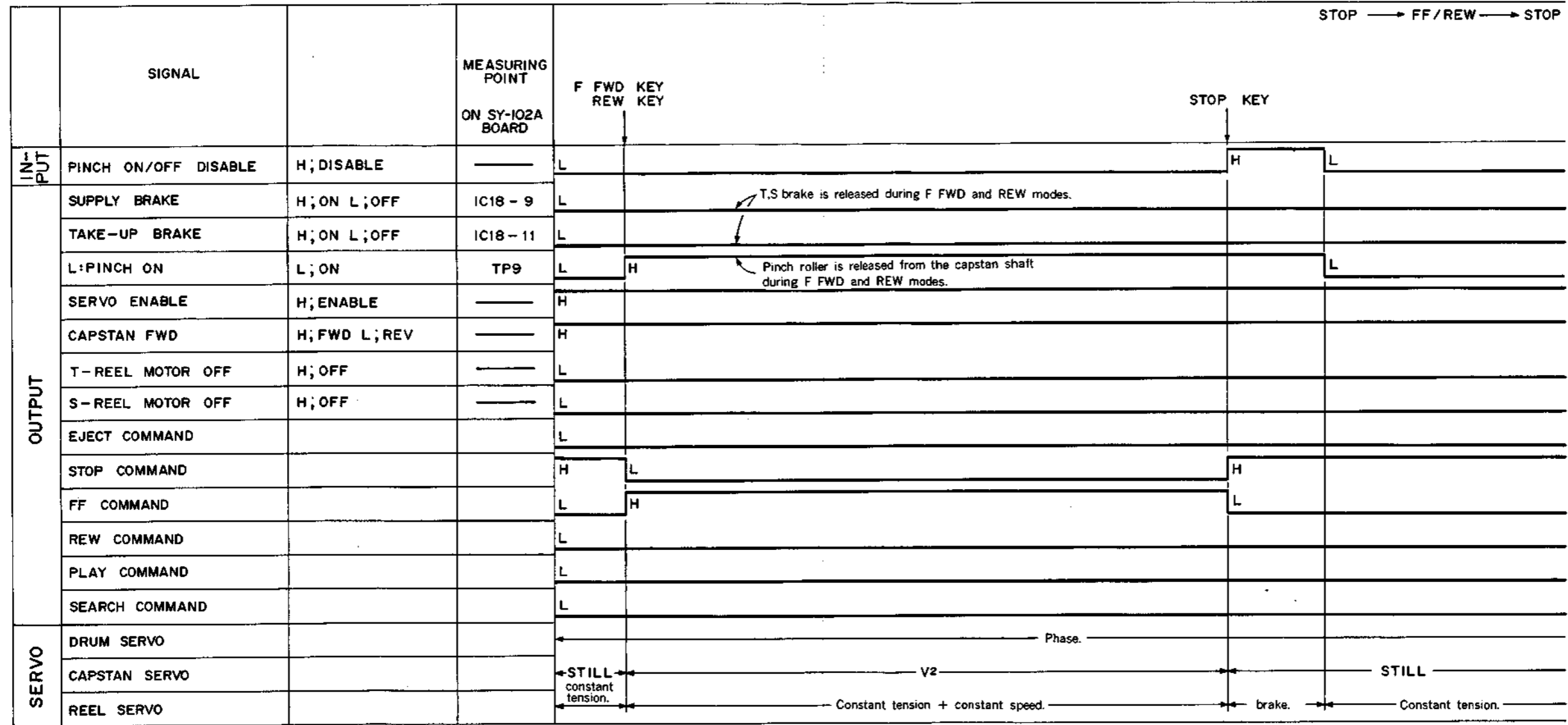

5. STOP → FWD SEARCH → REV SEARCH → STOP

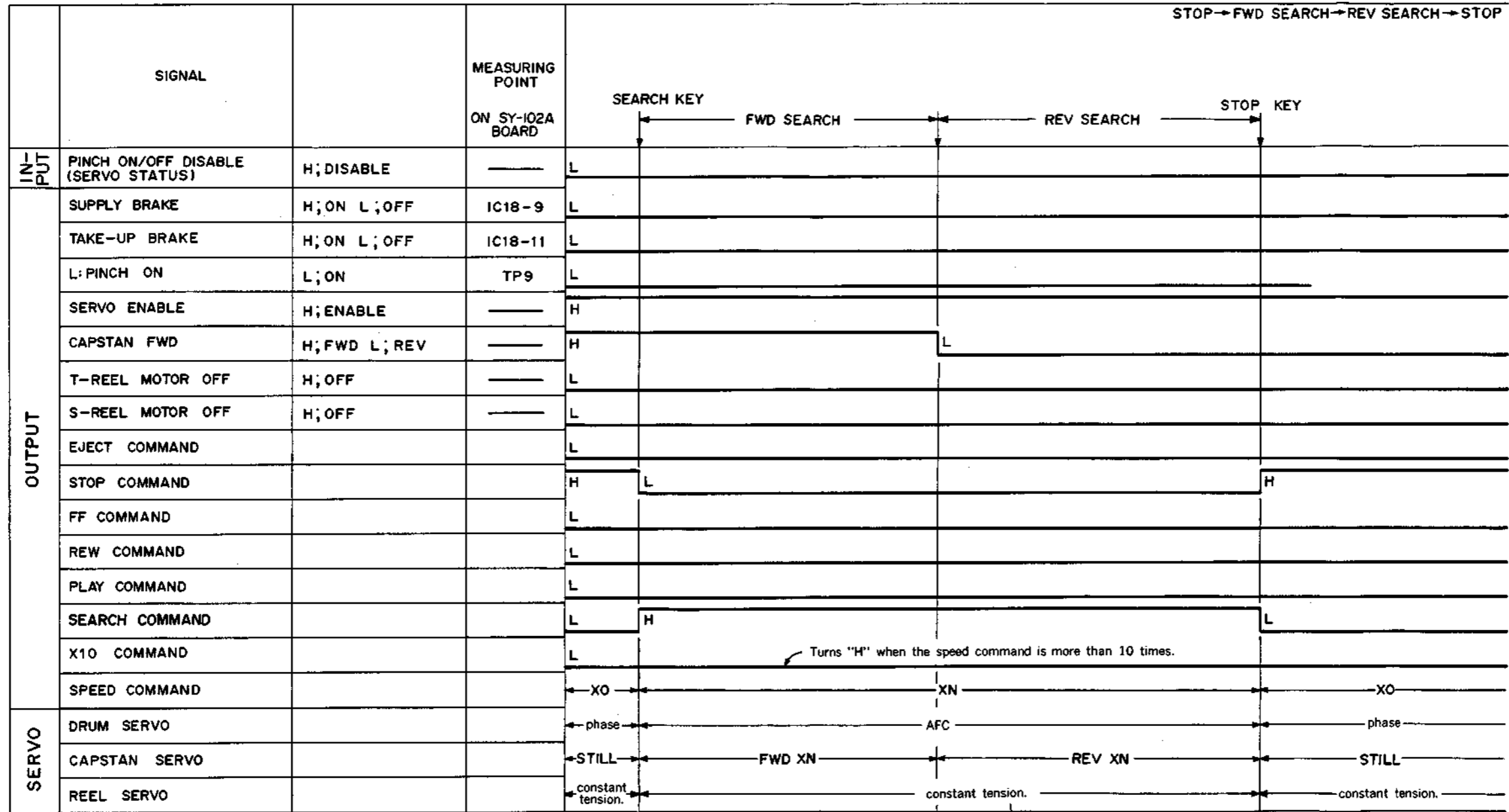

Turns "H" when the speed command is more than 10 times.

(when the speed command is 10 times, this period is constant tension + constant speed.)

6. STOP → STANDBY OFF → STOP

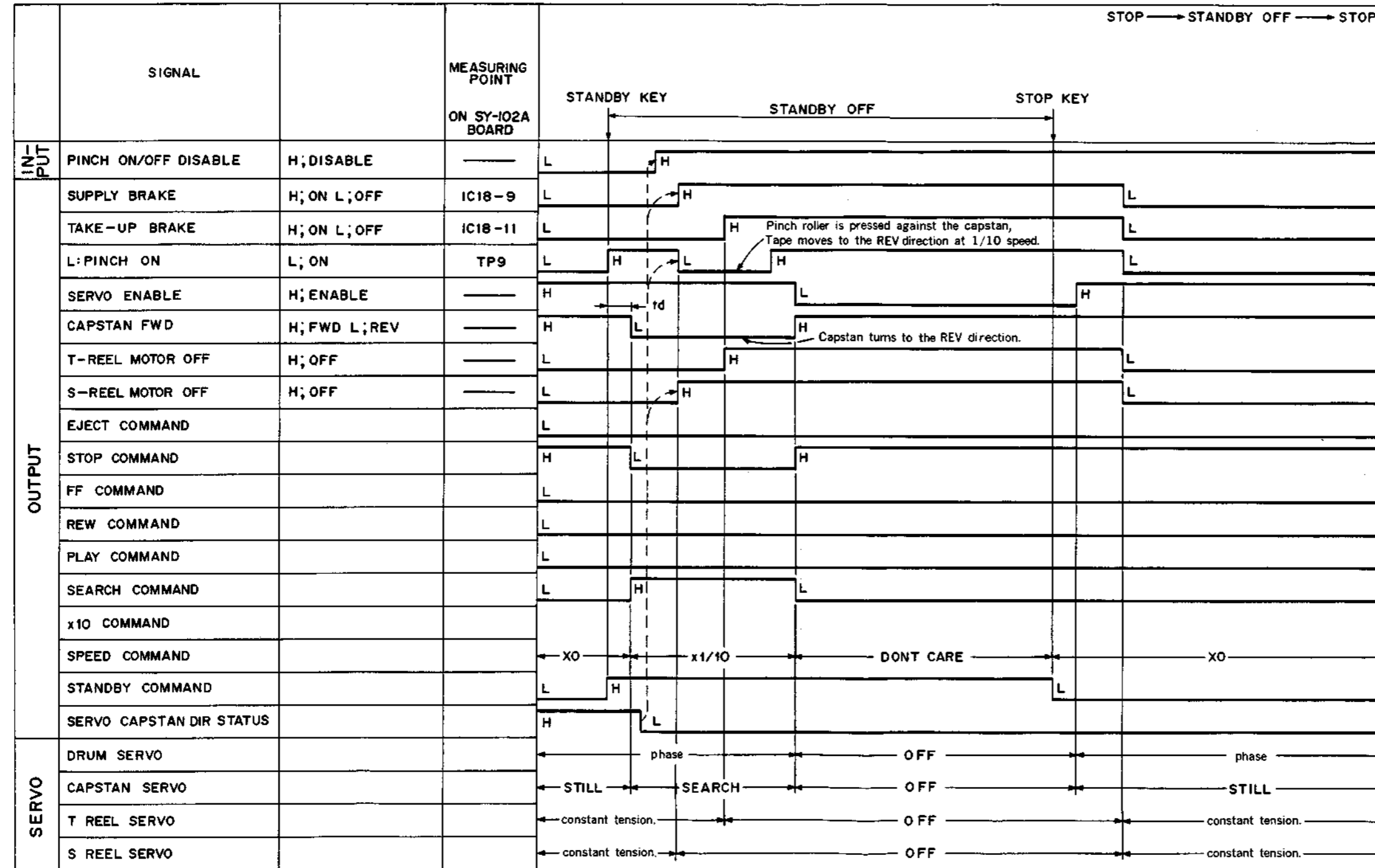

7. CASSETTE IN → SHORT FF → THREADING → STOP

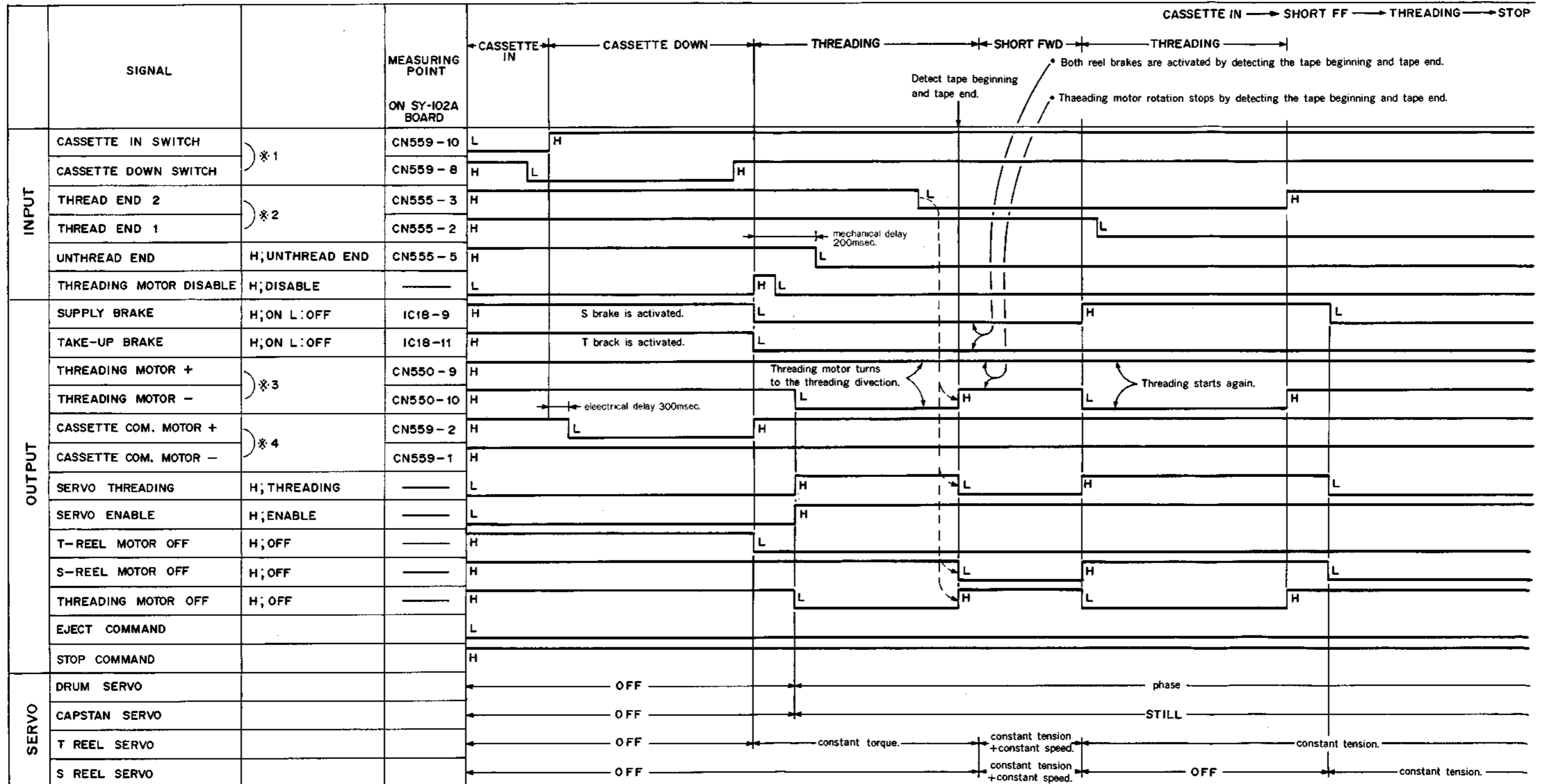



SECTION 3 PERIODIC CHECK AND MAINTENANCE

3-1. SYSTEM CONTROL OPERATION CHECK

It is recommended that the following checks are made daily before operating the unit. The check procedure described here is for the BVU-950P, with or without the remote control unit. Note that switches must be set the way the machine is used after the checks.

3-1-1. Play Back, F.FWD, REW, SHUTTLE, JOG and Preroll Function Check

- . Insert a recorded tape (Video, Audio CH-1/CH-2, Time Code). (Do not use an alignment tape.)
- . Connect a video and audio monitor.
- . The following procedures are used when ITEM NO.209, SELECTION FOR SEARCH DIAL ENABLE in DIAL MENU Operation is set to VIA SEARCH BUTTON. When it is set to DIAL DIRECT, the procedure indicated within double lines is not necessary. (Refer to Section 1-6 for further details.)

With switches set to :

POWER	: ON
REMOTE/LOCAL	: LOCAL
TC/CTL/DIAL MENU	: CTL
PB.PB/EE	: PB
AUDIO MONITOR	: MIX
TRACKING	: FIXED
SKEW	: DETENT POINT

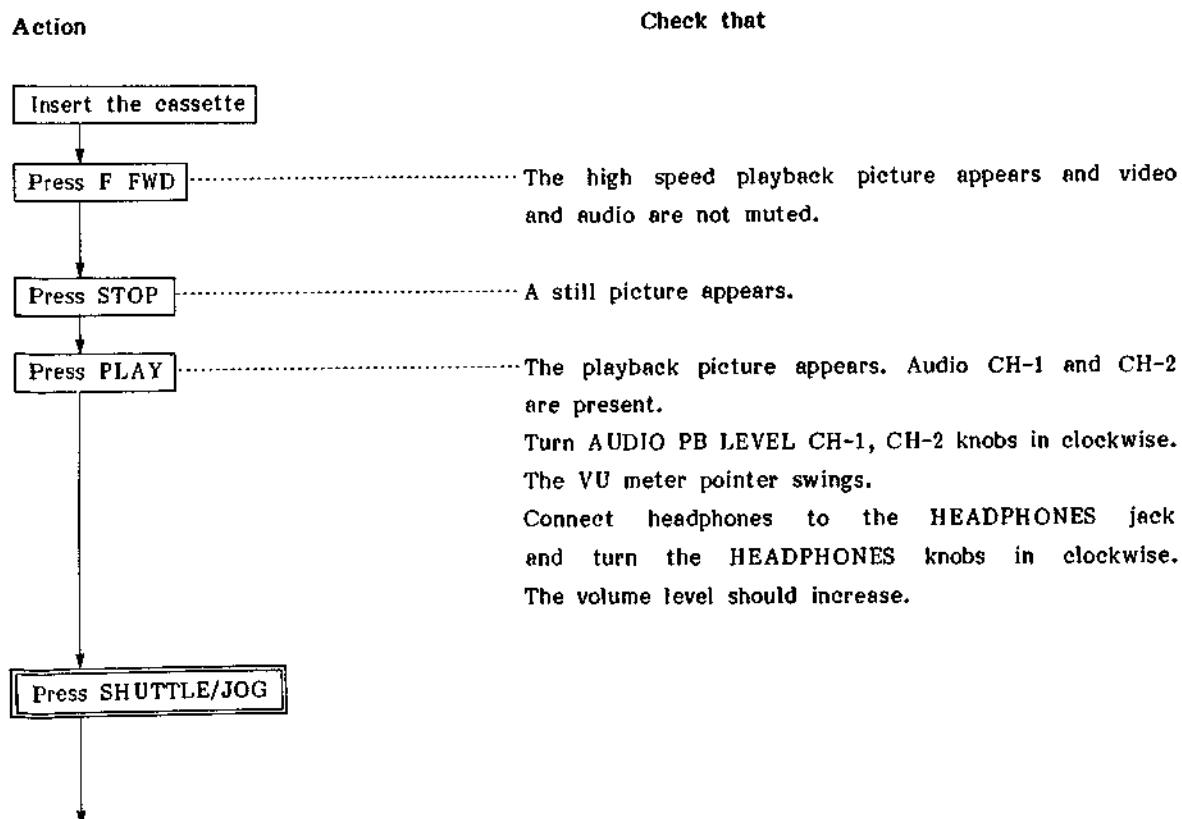

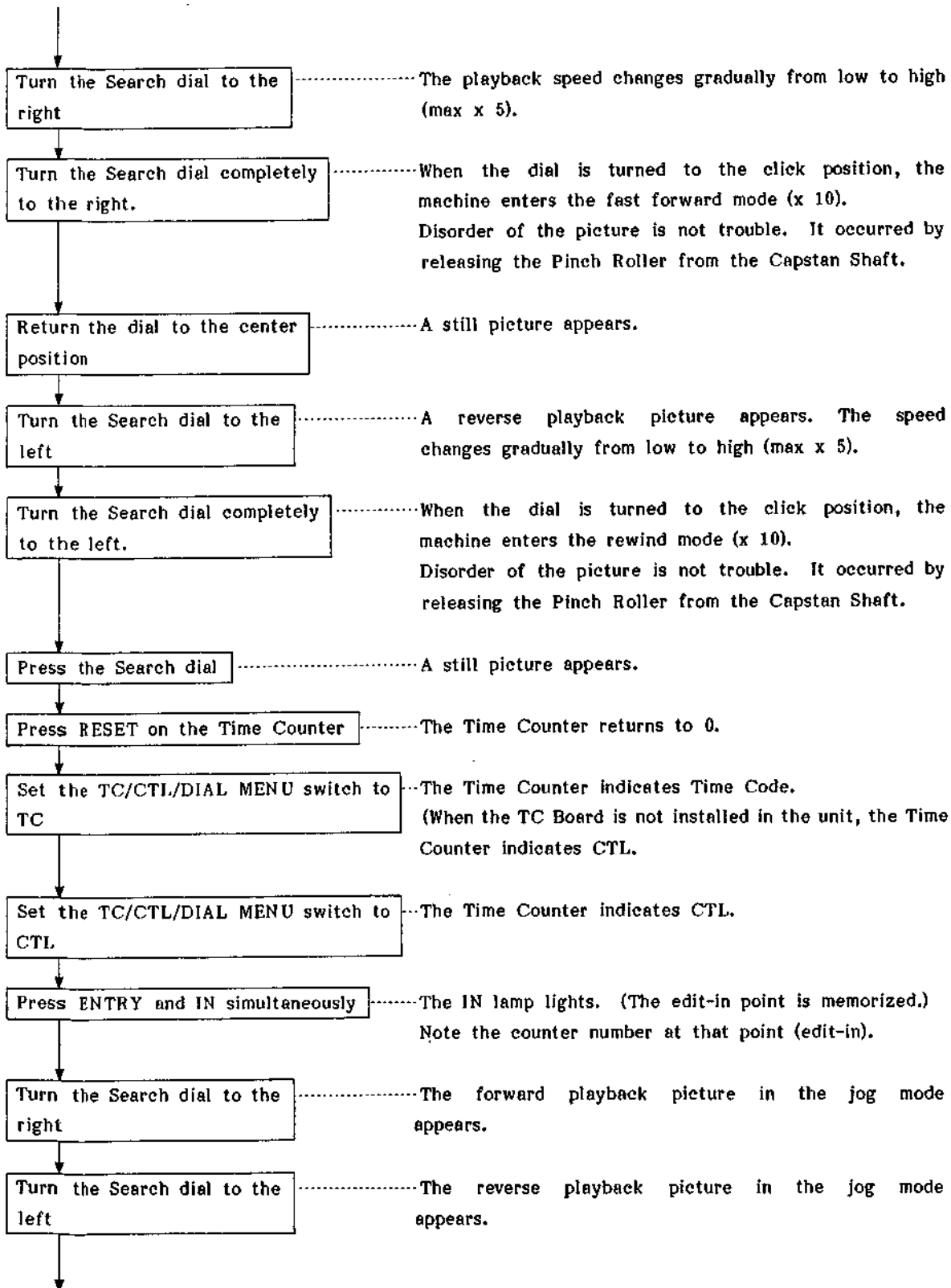

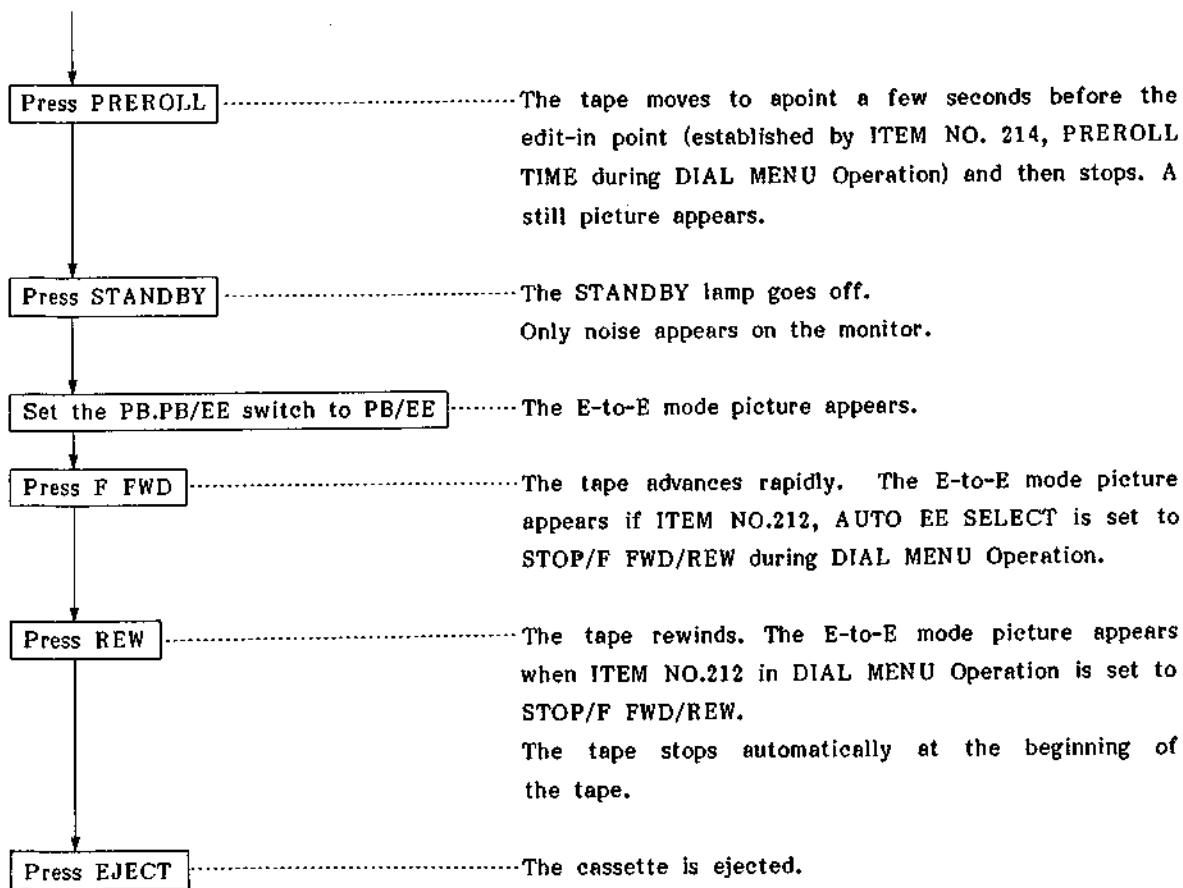

3-1-2. Record Function Check

- . Insert a video cassette tape on which a recording can be made.
- . Connect signals to the VIDEO IN, AUDIO IN CH-1 and CH-2 connectors.
- . Connect a video and audio monitor.

With switches set to : POWER : ON
 REMOTE/LOCAL : LOCAL
 INPUT SELECT : LINE
 PB.PB/EE : PB

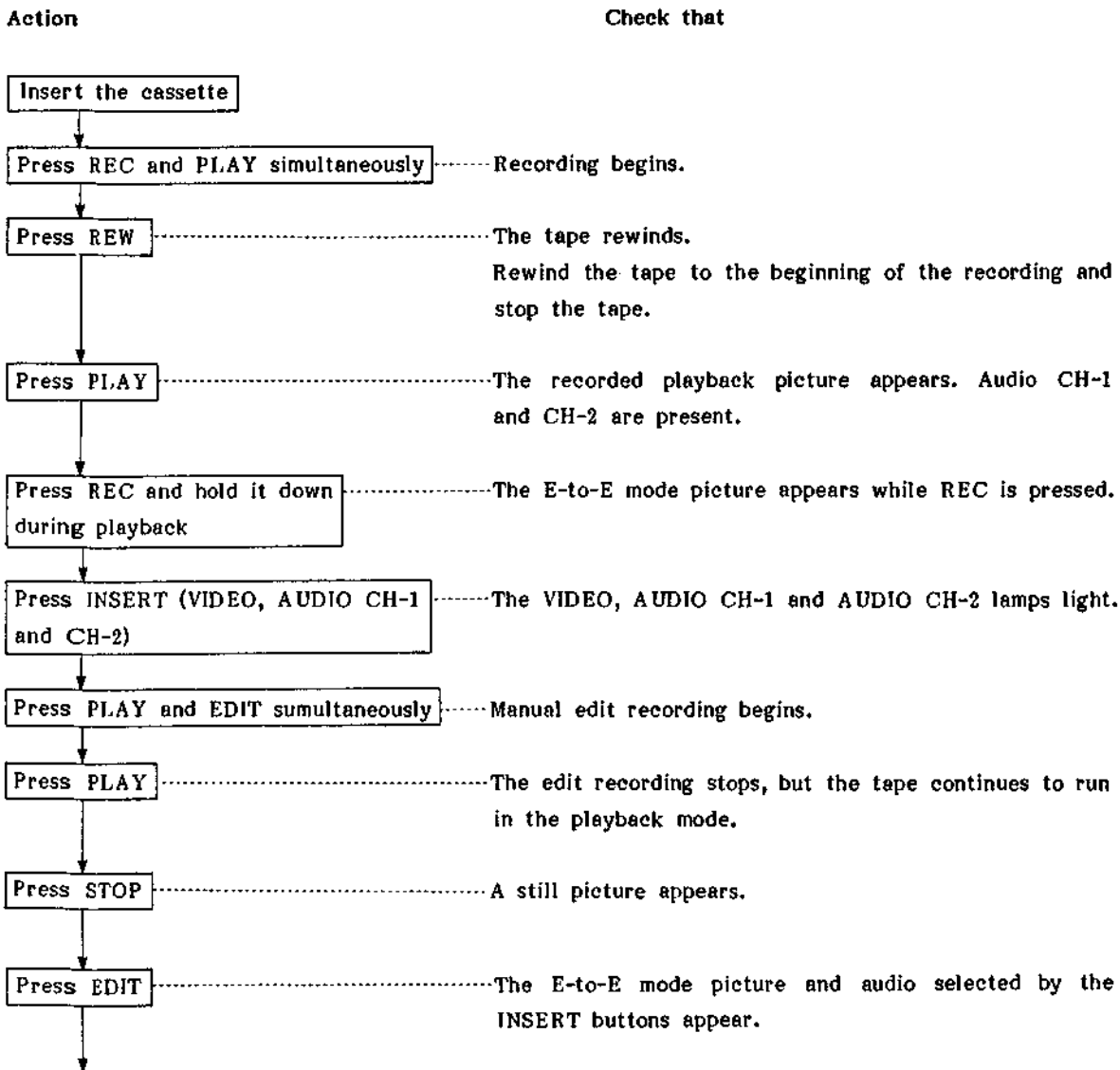

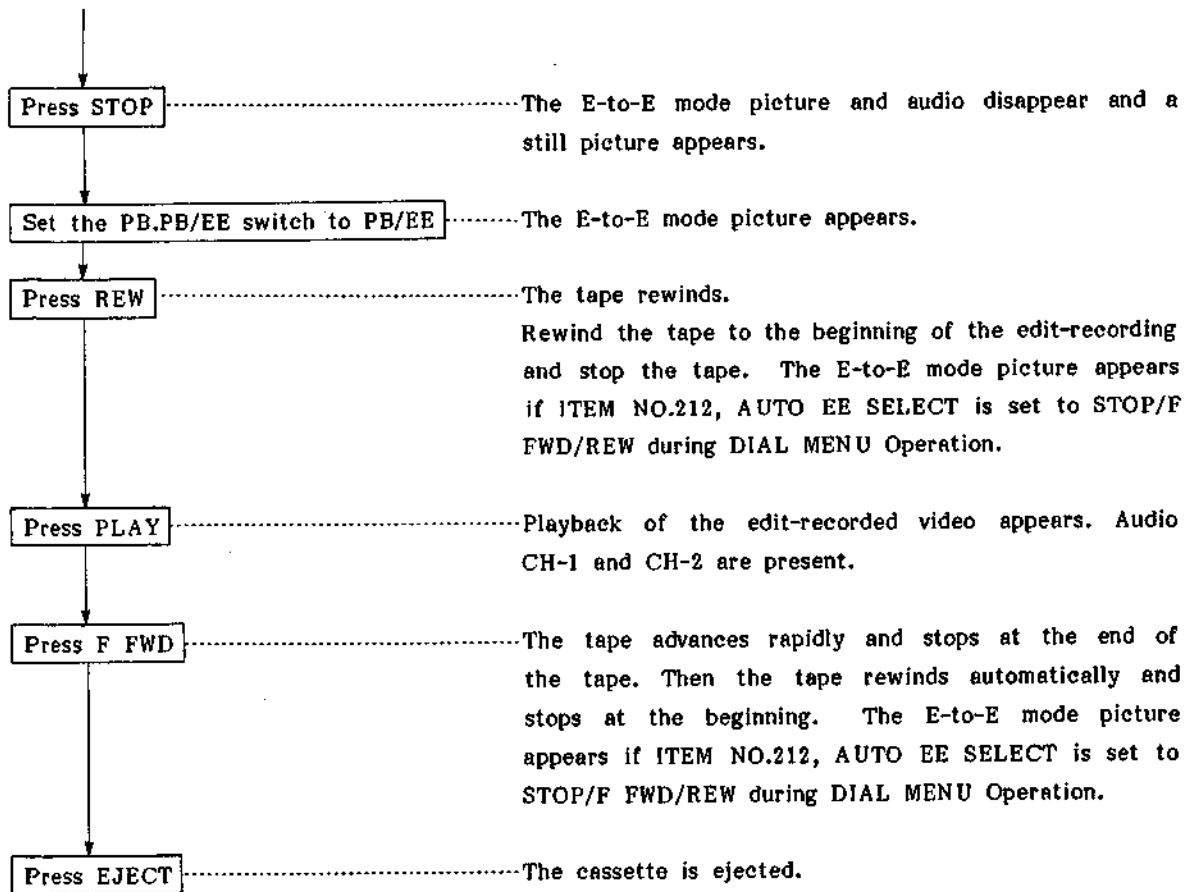

3-1-3. Editing Function Check

- Insert a recorded tape (Video, Audio CH-1/CH-2). (Do not use an alignment tape.)
- Connect signals to the VIDEO IN, AUDIO IN CH-1 and CH-2 connectors.
- Connect a video and audio monitor.
- The following procedures are used when ITEM NO.209, SELECTION FOR SEARCH DIAL ENABLE is set to VIA SEARCH BUTTON during DIAL MENU Operation.

(Refer to Section 1-6 for further details.)

With switches set to : POWER : ON
 REMOTE/LOCAL : LOCAL
 INPUT SELECT : LINE
 PB.PB/EE : PB

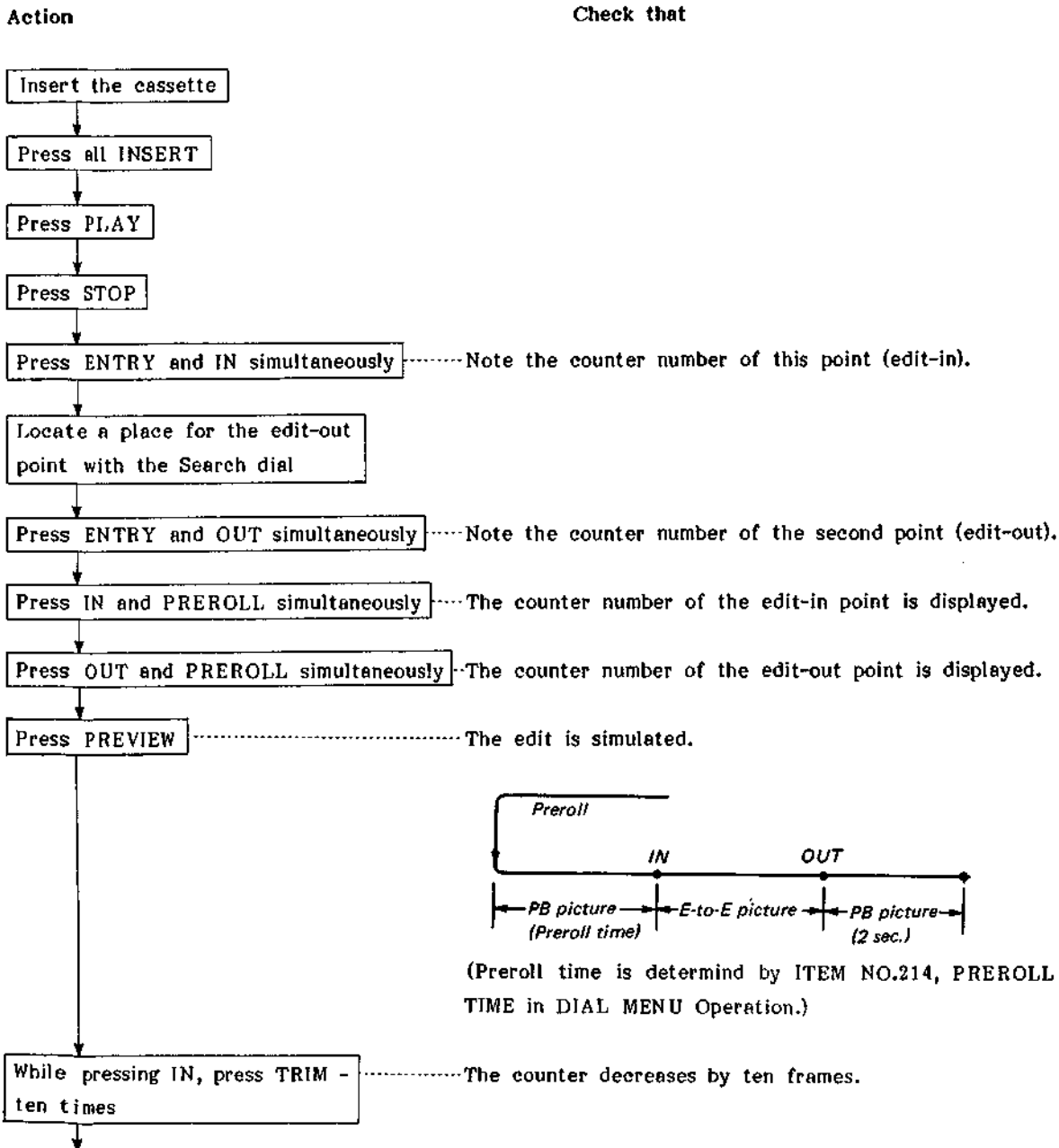

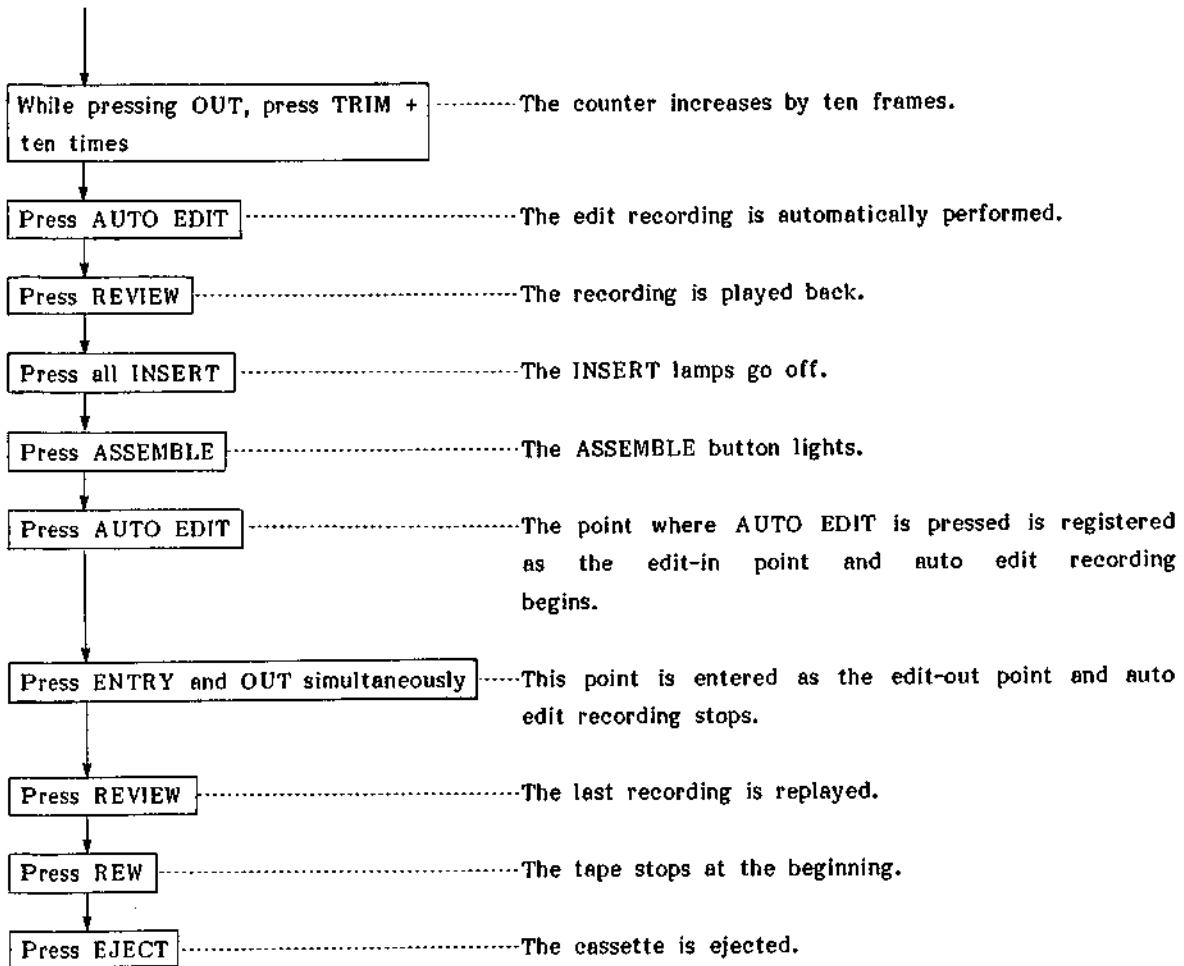

3-2. HOURS METER

The BVU-950P has an hours meter (DIAL MENU Operation, ITEM NO.205 and 206). It is recommended that the hours meter be used as a tool for scheduling periodic maintenance. (Refer to Section 1-6)

3-3. CLEANING PROCEDURE

Perform cleaning according to the following procedures. After cleaning, wait until the cleaning fluid completely evaporates before inserting a cassette.

3-3-1. Video Heads and Rotary Erase Heads

Press the cleaning piece moistened with cleaning fluid lightly against the drum and turn the drum slowly by hand.

(NOTE)

- 1 Never move the cleaning piece in a vertical direction with respect to the head during cleaning.
- 2 Always clean with the power OFF.

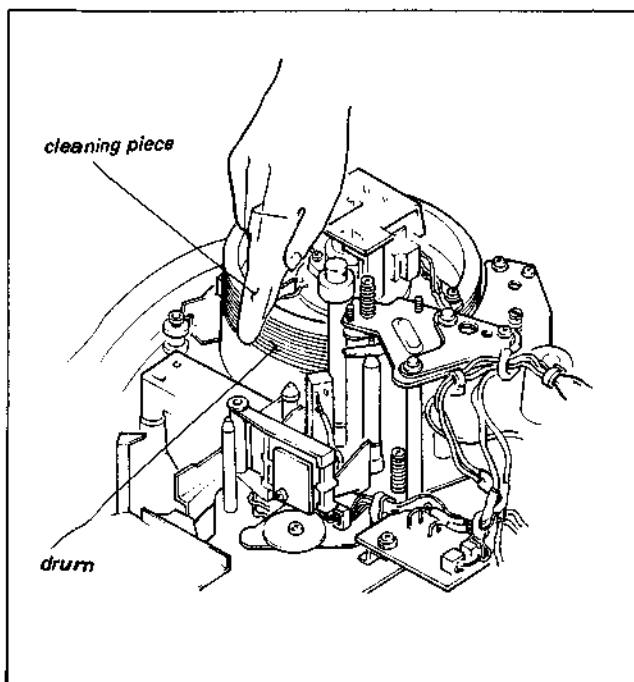

3-3-2. Stationary Heads

Clean with cleaning piece moistened with cleaning fluid.

3-3-3. Tape Movement Areas

Clean the tape bearing surface (tape guides, drum, capstan and pinch roller) with cleaning piece moistened with cleaning fluid.

(NOTE)

Do not clean the surface of the condensation sensor on the lower drum with cleaning fluid. Clean this surface with a dry cloth.

3-3-4. Slip-rings and Brushes

The Head Drum Assembly Slip-rings and Brushes do not require periodic cleaning. However, if dust adheres to the Slip-rings or Brushes, clean them as follows:

1. Clean the Slip-ring or Brush with a Soft Brush which has short hairs. If this Brush can not be obtained, use a Blower Brush and Cotton Swab.
2. Cleaning fluid is not especially necessary. However, if it is difficult to remove persistent debris, use Freon as a cleaning agent.

(NOTE)

1. Do not use alcohol as a cleaning fluid. If the Slip-ring and the Brushes are cleaned with alcohol, the surface tends to attract material which may increase the resistance at the contact area.
2. Do not use conductive grease.

3-4. HEAD DEGAUSSING

It is recommended to demagnetize the Rotary Heads and Stationary Heads with a demagnetizer when using the BVU-950P as a playback unit.

- . Bring the tip of the Demagnetizer as close as possible to the Head Tip without actually contacting it. Draw the Demagnetizer away from the head very slowly. Do not turn OFF the Demagnetizer until it is at least three feet away from the unit.

3-5. MAINTENANCE AFTER REPAIRS

Perform the following maintenance after repair (the unit operating hours are not important):

1. Clean the video heads, rotary erase heads and stationary heads.
(Refer to Section 3-3-1 and 3-3-2)
2. Clean the tape movement area.
(Refer to Section 3-3-3)



SECTION 4 SERVICE INFORMATION

S/N UP TO 13680

4-1. REMOVAL AND INSTALLATION OF THE CABINET

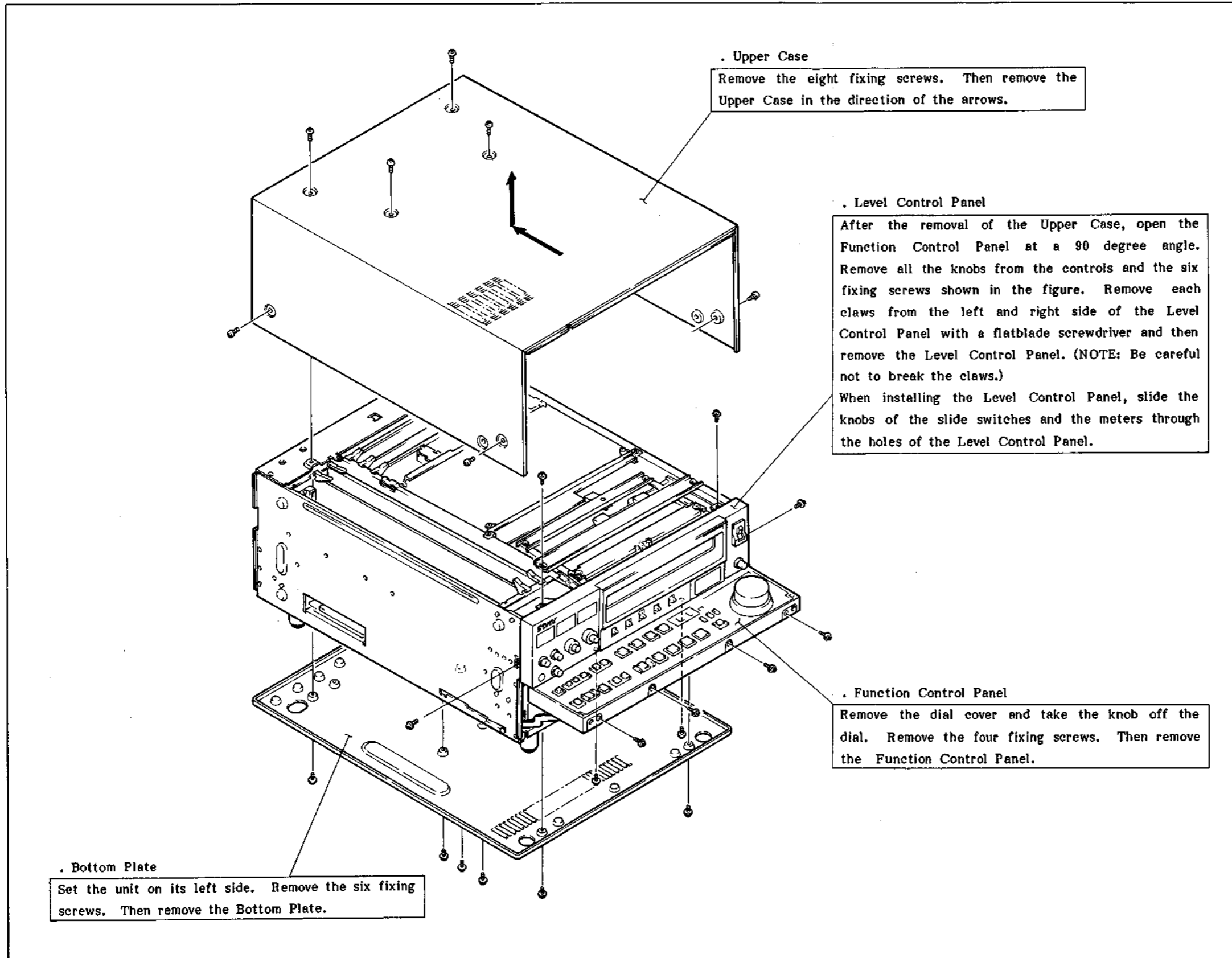

4-1 (a)

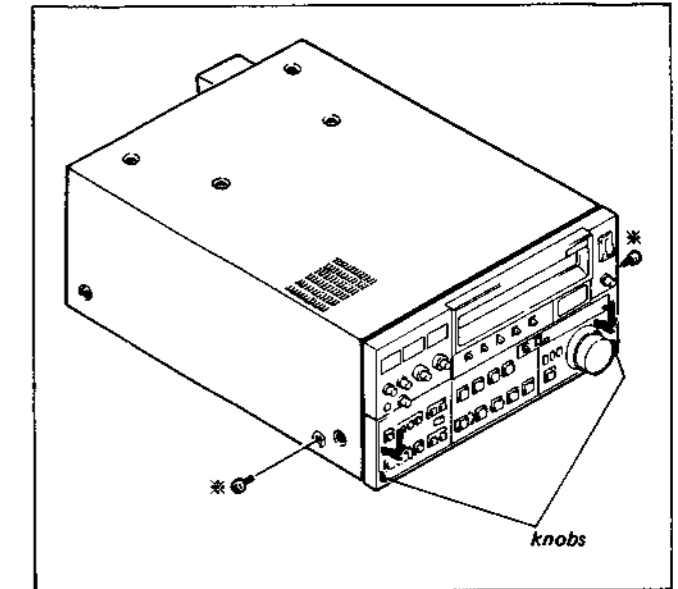

1. Remove the two fixing screws marked with * shown in the figure. These fixing screws secure the Function Control Panel to the unit for transport.

When transporting the unit, release the locks on the arms. Press the knobs on the front of the Function Control Panel in the direction of the arrows shown in the figure and tighten the fixing screws.

2. Remove the each claw on the left and right side of the Level Control Panel with a flatblade screwdriver.

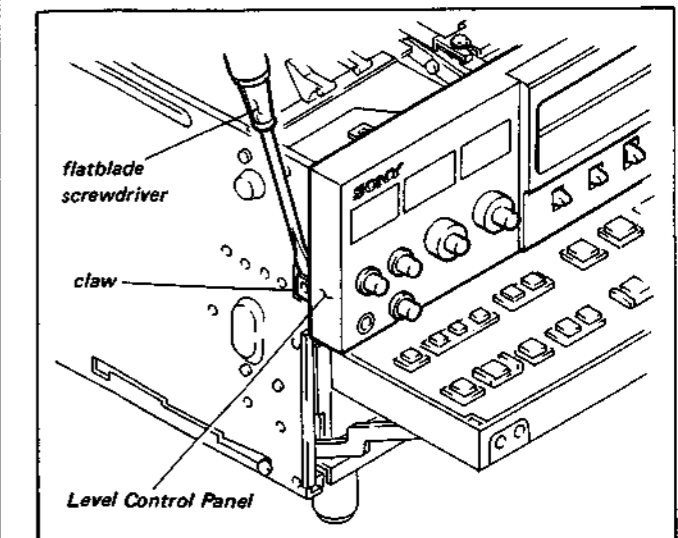

4-2 (a)

4-2. REMOVAL AND INSTALLATION OF THE FUNCTION CONTROL PANEL

. Removal

1. Push down the right and left knobs on the front of the Function Control Panel and open the Panel at a 90 degree angle.

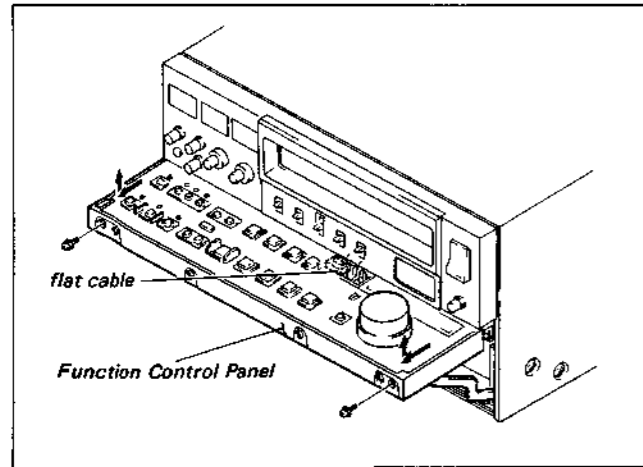

2. Disconnect the Flat Cable connected to the back of the Function Control Panel.
3. Remove the two fixing screws from the right and left ends of the Function Control Panel.
4. Slide the Function Control Panel in the direction of the arrows and remove it.

. Installation

5. Install the two hooks on the right and left arms of the unit to the Function Control Panel, and shift the Function Control Panel in the direction of the arrows. Then tighten the two fixing screws.

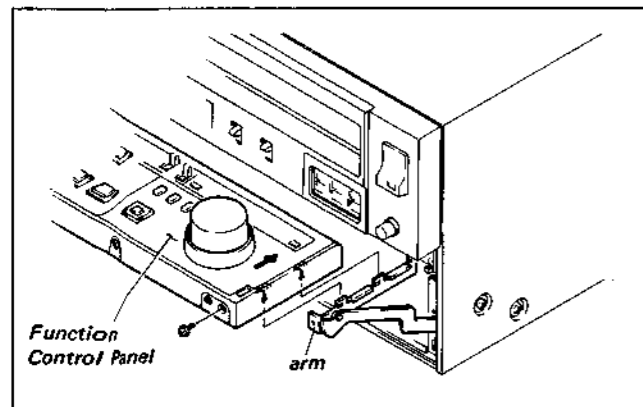

6. Connect the Flat Cable.

4-3 (a)

4-3. REMOVAL OF THE CASSETTE-UP COMPARTMENT

1. Remove the Upper Case.
2. Remove the two fixing screws and the Cassette-up Compartment Stay.
3. Lift the right side of the Cassette-up Compartment and disconnect connector CN1 on the CC-31 Board. The Cassette-up Compartment can now be removed from the unit.

(NOTE)

When the Cassette-up Compartment Stay is installed, position the right and left ends as shown in the figure.

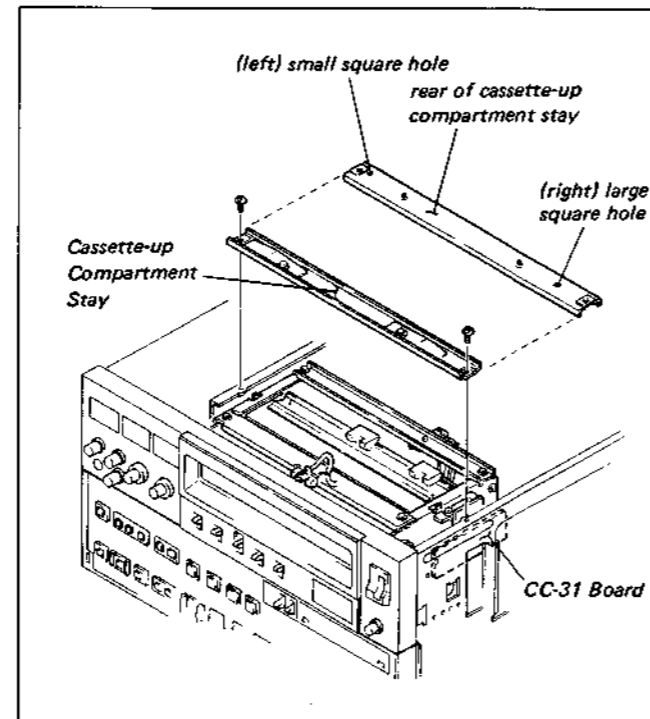

4-4. SERVICE OF THE SPECIAL PRINTED CIRCUIT BOARDS

4-4-1. SERVICE OF THE RP-30A PRINTED CIRCUIT BOARD

1. Remove the Upper Case.
2. Remove the two fixing screws as shown in the figure.

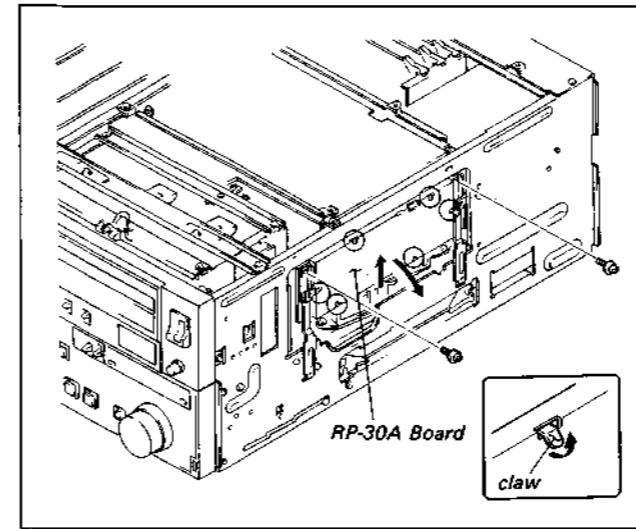

3. Lift up and then open the RP-30A Board. (When the RP-30A Board is put back, raise up the Board slightly to lock it in place.)
4. Lift the claws on the shield case and remove the lid.

Removal of the shield case on the component side: Lift the five claws and remove the lid.

Removal of the shield case on the soldering side: Lift the six claws and remove the lid.

(NOTE)

When the unit is rack-mounted, pull the unit from the rack. Remove the Inner Members of the Slides Rails and then service the unit.

4-4 (a)

4-4-2. REPLACEMENT OF PARTS ON THE HN-80 PRINTED CIRCUIT BOARD

1. Remove the Upper Case.
2. Remove the AU-83A, AU-84A, AU-85A and BC-11 Boards.
3. Open the MD-45 Board.
4. Unsolder and replace parts as necessary.

(NOTE)

Never remove the HN-80 Board from the unit when replacing parts on this Board.

4-4-3. REMOVAL OF THE PD-37 PRINTED CIRCUIT BOARD

1. Remove the Upper Case.
2. Remove the Cassette-up Compartment.
3. Remove the Bottom Plate and then open the SY-102A Board.
4. Disconnect the seven connectors on the PD-37 Board from the bottom of the unit.
5. Disconnect the four connectors on the PD-37 Board from the top of the unit.
6. Remove the two white fasteners. Pull up the PD-37 Board.
7. Install the PD-37 Board to the unit by reversing steps (1) to (6).

4-4-4. REPLACEMENT OF THE MB-139 PRINTED CIRCUIT BOARD

. Removal

1. Remove the Upper Case and all the plug-in boards.
2. Remove the Bottom Plate and open the SY-102A Board.
3. Disconnect all the connectors on the SY-102A Board and then remove the SY-102A Board.
4. Remove the twelve fixing screws in the holes on the MB-127 Board. (Be careful not to drop the screws into the unit.)

SECTION 4 SERVICE INFORMATION

S/N 13681 AND HIGHER

4-1. REMOVAL AND INSTALLATION OF THE CABINET

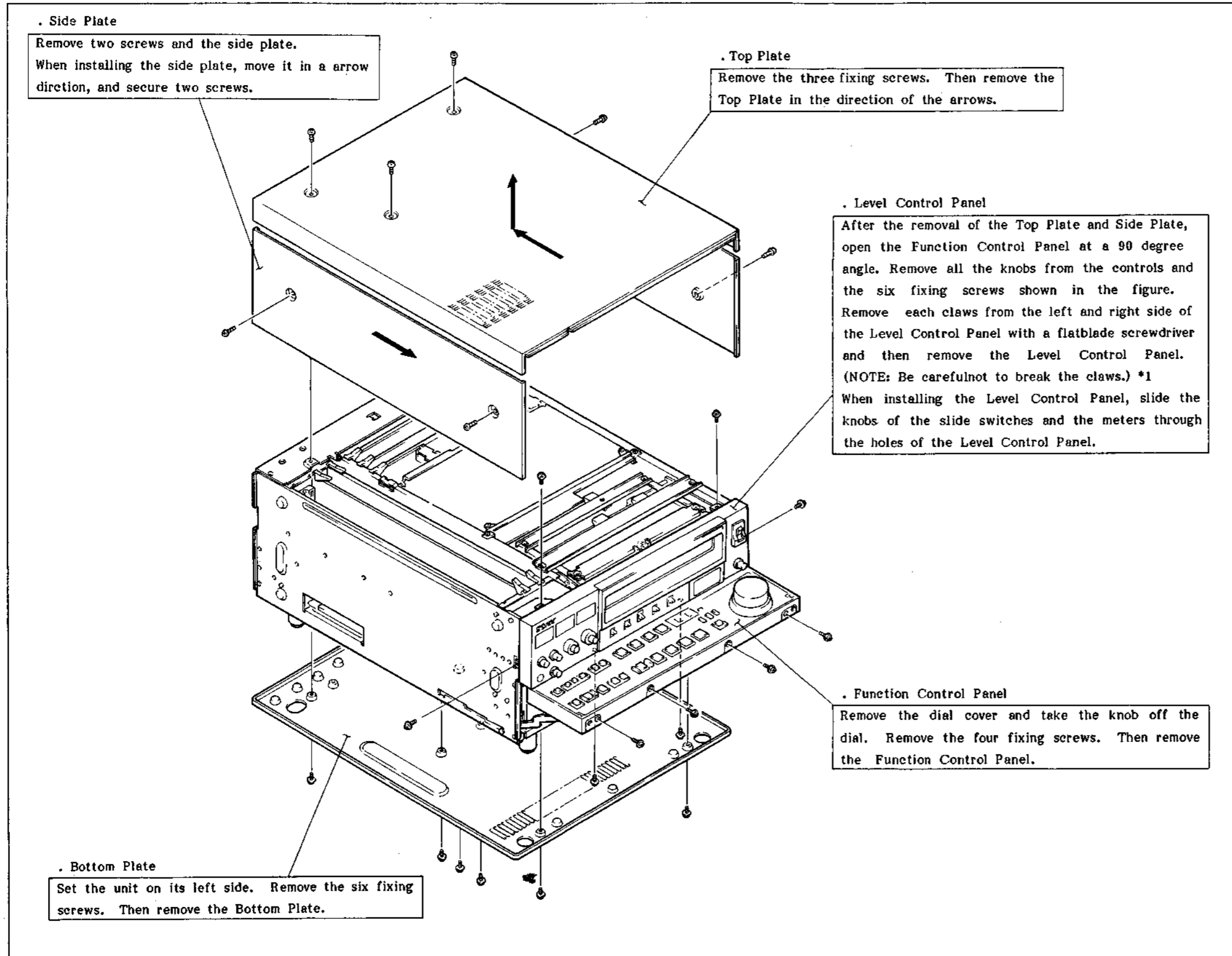

4-1(b)

*1. Remove the each claw on the left and right side of the Level Control Panel with a flatblade screwdriver.

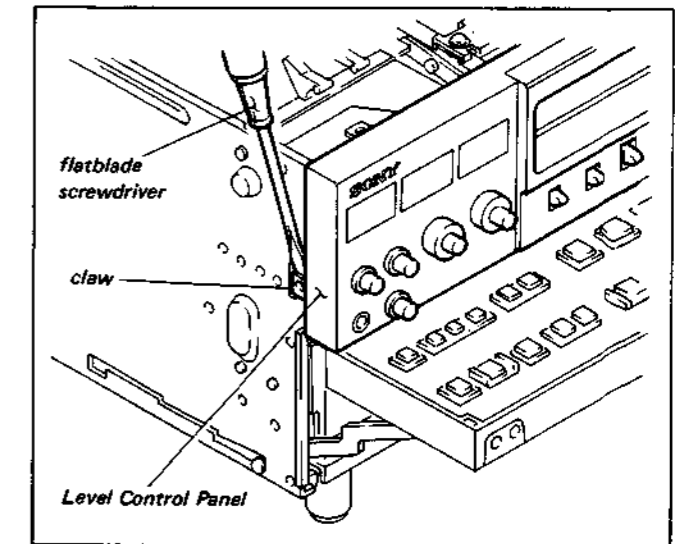

4-2(b)

4-2. REMOVAL AND INSTALLATION OF THE FUNCTION CONTROL PANEL

. Removal

1. Push down the right and left knobs on the front of the Function Control Panel and open the Panel at a 90 degree angle.

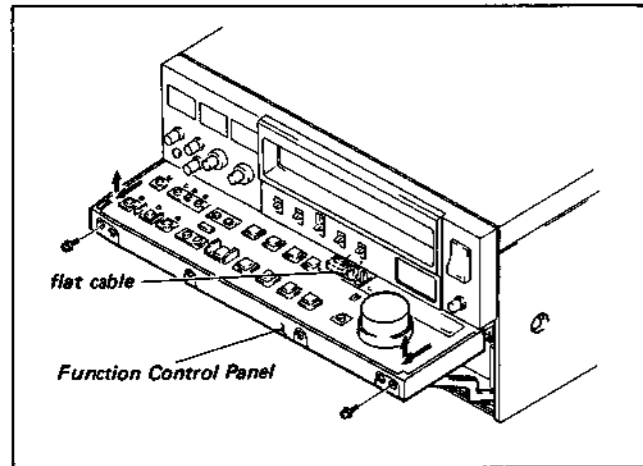

2. Disconnect the Flat Cable connected to the back of the Function Control Panel.
3. Remove the two fixing screws from the right and left ends of the Function Control Panel.
4. Slide the Function Control Panel in the direction of the arrows and remove it.

. Installation

5. Install the two hooks on the right and left arms of the unit to the Function Control Panel, and shift the Function Control Panel in the direction of the arrows. Then tighten the two fixing screws.

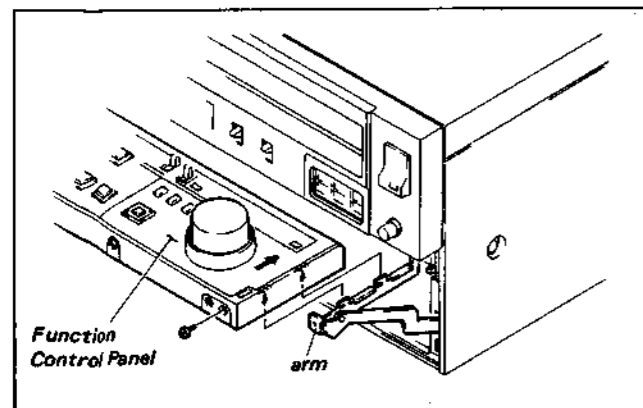

6. Connect the Flat Cable.

4-3 (b)

4-3. REMOVAL OF THE CASSETTE-UP COMPARTMENT

1. Remove the Top Plate.
2. Remove the two fixing screws and the Cassette-up Compartment Stay.
3. Lift the right side of the Cassette-up Compartment and disconnect connector CN1 on the CC-36 Board. The Cassette-up Compartment can now be removed from the unit.

(NOTE)

When the Cassette-up Compartment Stay is installed, position the right and left ends as shown in the figure.

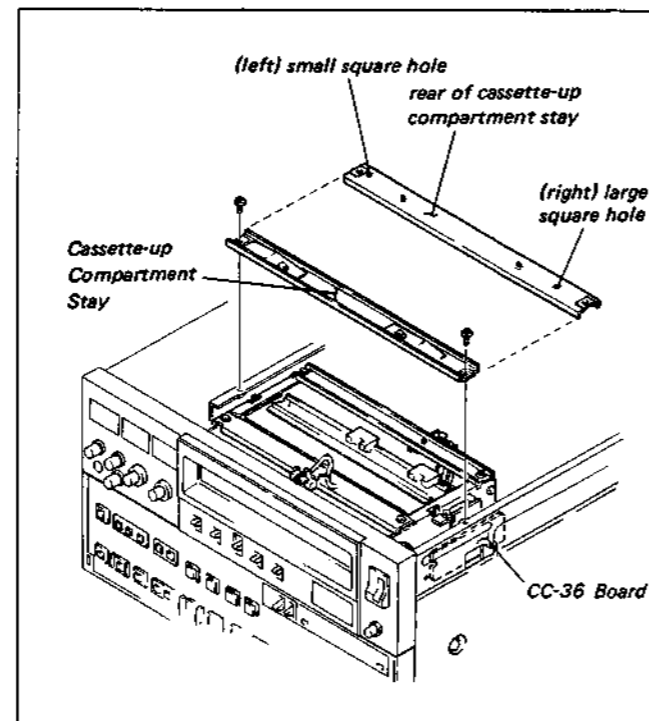

4-4. SERVICE OF THE SPECIAL PRINTED CIRCUIT BOARDS

4-4-1. SERVICE OF THE RP-30A PRINTED CIRCUIT BOARD

1. Remove the Top Plate.
2. Remove the two fixing screws as shown in the figure.

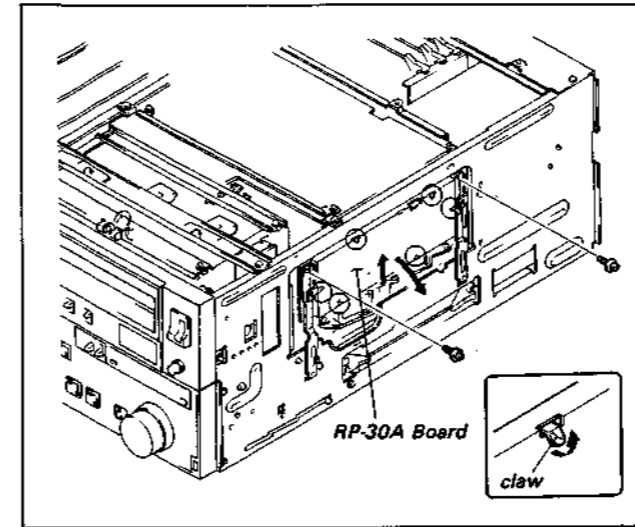

3. Lift up and then open the RP-30A Board. (When the RP-30A Board is put back, raise up the Board slightly to lock it in place.)
4. Lift the claws on the shield case and remove the lid.

Removal of the shield case on the component side:

Lift the five claws and remove the lid.

Removal of the shield case on the soldering side:

Lift the six claws and remove the lid.

(NOTE)

When the unit is rack-mounted, pull the unit from the rack. Remove the Inner Members of the Slides Rails and then service the unit.

4-4-2. REPLACEMENT OF PARTS ON THE HN-80 PRINTED CIRCUIT BOARD

1. Remove the Top Plate.
2. Remove the AU-83A, AU-84A, AU-85A and BC-11 Boards.
3. Open the MD-45 Board.
4. Unsolder and replace parts as necessary.

(NOTE)

Never remove the HN-80 Board from the unit when replacing parts on this Board.

4-4-3. REMOVAL OF THE PD-37 PRINTED CIRCUIT BOARD

1. Remove the Top Plate.
2. Remove the Cassette-up Compartment.
3. Remove the Bottom Plate and then open the SY-102A Board.
4. Disconnect the seven connectors on the PD-37 Board from the bottom of the unit.
5. Disconnect the four connectors on the PD-37 Board from the top of the unit.
6. Remove the two white fasteners. Pull up the PD-37 Board.
7. Install the PD-37 Board to the unit by reversing steps (1) to (6).

4-4-4. REPLACEMENT OF THE MB-139 PRINTED CIRCUIT BOARD

. Removal

1. Remove the Top Plate and all the plug-in boards.
2. Remove the Bottom Plate and open the SY-102A Board.
3. Disconnect all the connectors on the SY-102A Board and then remove the SY-102A Board.
4. Remove the twelve fixing screws in the holes on the MB-127 Board. (Be careful not to drop the screws into the unit.)

4-4 (b)

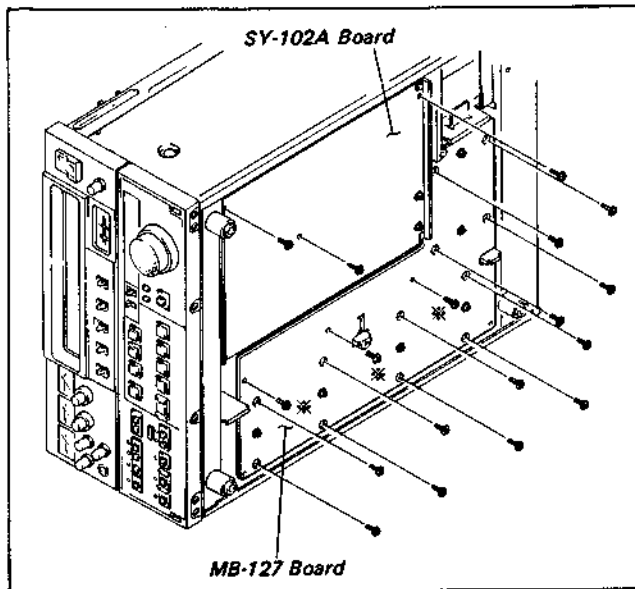

5. Remove the three fixing screws marked with * shown in the figure.
6. Remove the two fixing screws and then remove the V harness holder.
7. Remove the two fixing screws and the TC-Stay.

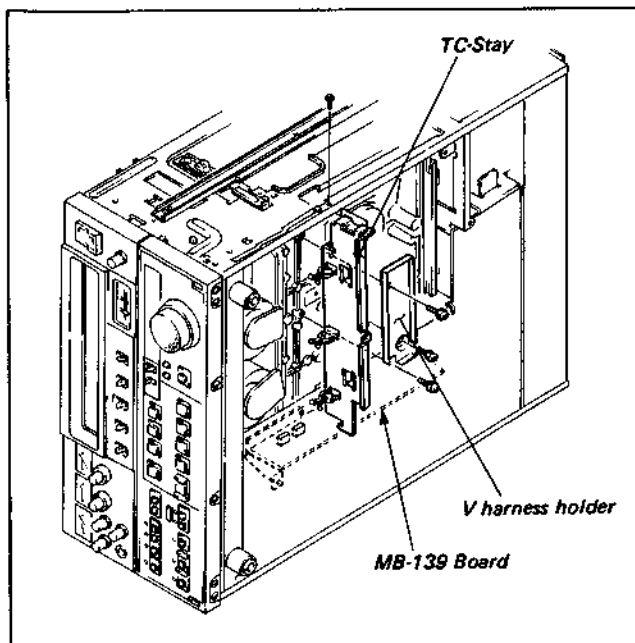

8. Disconnect the two connectors on the MB-139 Board.
9. Push the MB-139 Board toward the chassis while holding the MB-127 Board. Then disconnect the three connectors between the MB-127 Board and the MB-139 Board and remove the MB-139 Board.

. Installation

10. Replace the MB-139 Board with a new one and connect the three connectors with the MB-127 Board (CN241 to CN243).
11. Attach the MB-139 Board to the MB-127 board with three fixing screws.
12. Install the MB-127 Board with twelve fixing screws.
13. Attach the TC-Stay. Insert the projection of the TC-Stay in the square hole of the MB-139 Board Bracket as shown in the figure.

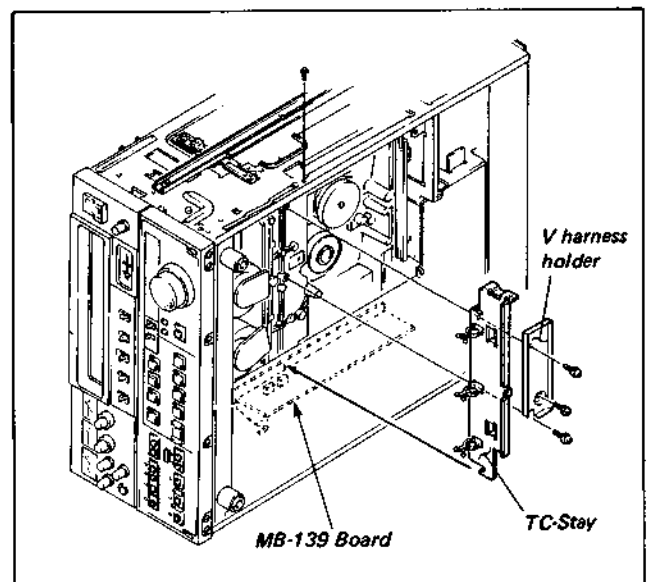

14. Install the V harness holder.
15. Connect the two connectors on the MB-139 Board (CN234, CN235).
16. Connect all the connectors on the SY-102A Board.
17. Install the SY-102A Board.
18. Attach the Bottom Plate.
19. Install the plug-in boards in the appropriate positions.
20. Install the Top Plate.

4-4-5. REMOVAL OF THE DR-53 AND DR-59 PRINTED CIRCUIT BOARDS

1. Remove the two fixing screws and open the Connector Panel.

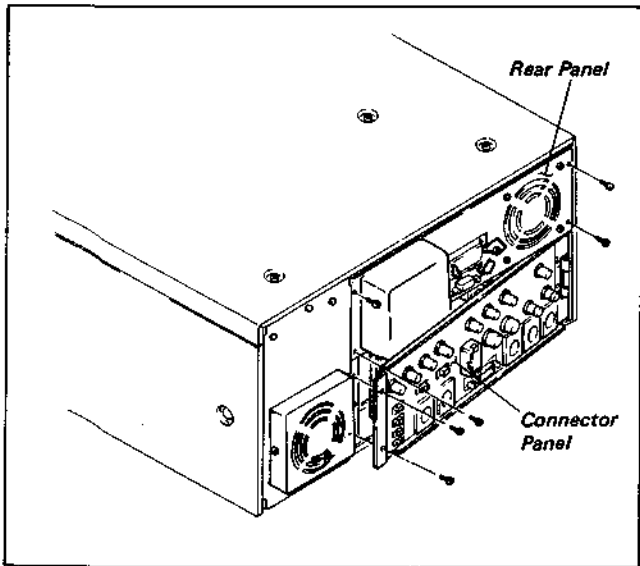

2. Remove four fixing screws and remove the Rear Panel.
3. Disconnect seven connectors on the DR-53 Board and one connector on the DR-59 Board.

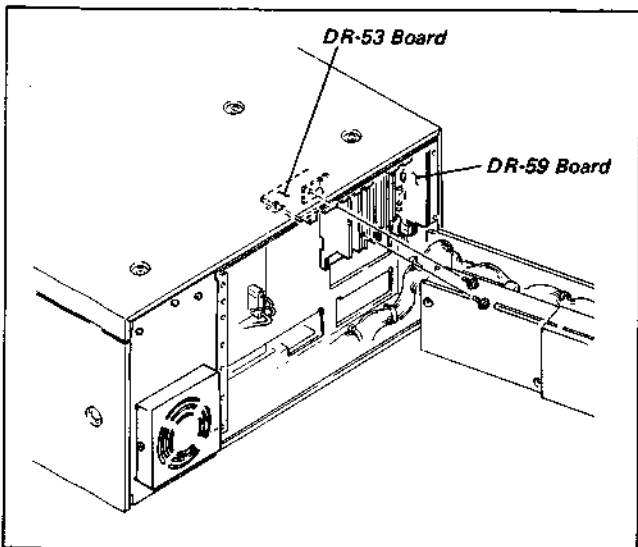

4. Remove the two fixing screws shown in the figure and remove the DR-53 and DR-59 Boards.

4-5. REMOVAL AND INSTALLATION OF THE POWER BLOCK

. Removal

1. Remove the Top Plate.
2. Remove the two fixing screws as shown in the figure.

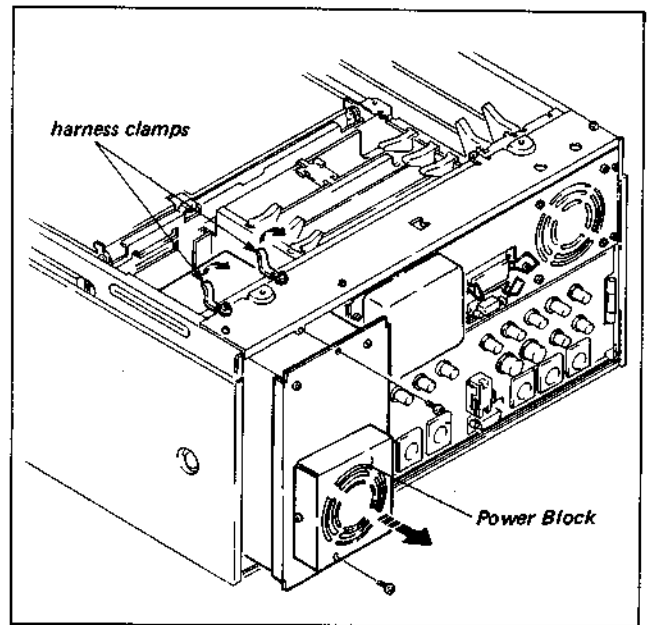

3. Lift the harness clamps.
4. Disconnect the three connectors on the top of the Power Block.
5. Lift up the harness.
6. Pull the Power Block out of the unit in the direction of the arrow.

. Installation

7. Install the Power Block in the unit and connect the connectors.
8. Secure the harness with the clampers.
9. Tighten the two fixing screws.

4-4-5. REMOVAL OF THE DR-53 AND DR-59 PRINTED CIRCUIT BOARDS

1. Remove the two fixing screws and open the Connector Panel.

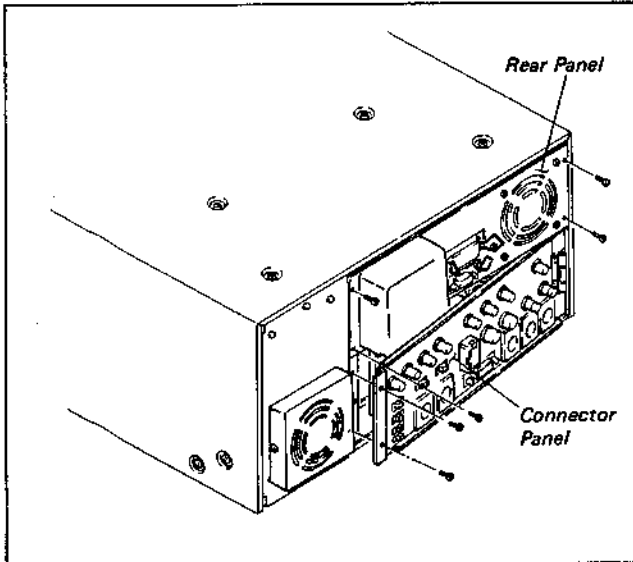

2. Remove four fixing screws and remove the Rear Panel.
3. Disconnect seven connectors on the DR-53 Board and one connector on the DR-59 Board.

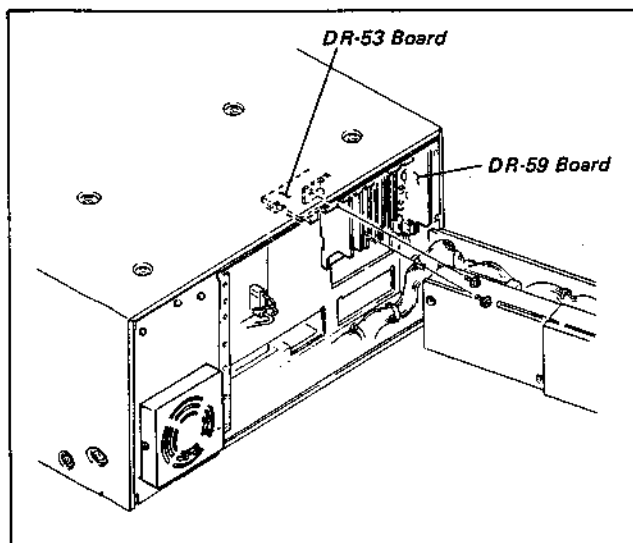

4. Remove the two fixing screws shown in the figure and remove the DR-53 and DR-59 Boards.

4-5. REMOVAL AND INSTALLATION OF THE POWER BLOCK

. Removal

1. Remove the Upper Case.
2. Remove the two fixing screws as shown in the figure.

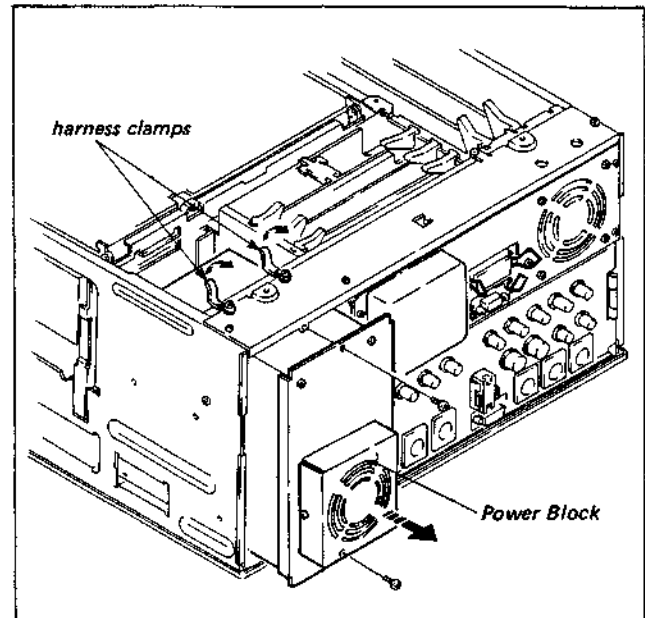

3. Lift the harness clamps.
4. Disconnect the three connectors on the top of the Power Block.
5. Lift up the harness.
6. Pull the Power Block out of the unit in the direction of the arrow.

. Installation

7. Install the Power Block in the unit and connect the connectors.
8. Secure the harness with the clampers.
9. Tighten the two fixing screws.

S/N UP TO 13730

4-6. EXTENSION BOARD

The Amp chassis printed circuit boards listed can be serviced by using two kinds of Extension Boards. Simply insert the Extension Board into the Amp chassis and connect the circuit board to be serviced to the end of the Extension Board.

(NOTE)

Be sure to turn OFF power before inserting or removing the Extension Board or printed circuit boards.

Printed circuit board	Extension Board
SV-88A DM-55 (TBC-6)	EX-128
AU-83A AU-84A AU-85A BC-11 (TC-42)	EX-127

4-7. OPERATION OF THE UNIT WITHOUT INSTALLING THE CASSETTE-UP COMPARTMENT AND THE CASSETTE TAPE

The unit have the tape beginning and tape end sensors so that detect the tape top and tape end. For operating the unit without installing the Cassette-up Compartment and the cassette tape, disable the Tape Beginning Sensor and the Tape End Sensor.

1. Remove the Upper Case or Top Plate and Side Plate. (Refer to Section 4-1)
2. Short between TP10 (location No. F-1) and GND on the SY-102A Board with a shorting clip from the entrance of the Time Code Board.
Tape Beginning Sensor and the Tape End Sensor stop their operation.

(NOTE)

Never forget to remove the shorting clip after the check and adjustment.

If the unit is placed into the F FWD or REW mode without removing the shorting clip, the unit cannot detect the tape beginning or tape end. So the unit cannot operate the AUTO STOP operation. The tape and the unit are put into the dangerous situation.

3. Set the Bit7 of S201 (location No. K-1) on the SV-88A Board to ON and the Bit8 to OFF. Set S202 (M-1) on the SV-88A Board to ON.

(NOTE)

After the check and adjustment, reset S201 and S202.

4. Turn the POWER ON.

The Threading Ring turns automatically, unit is put into the threading completion mode.

5. Press the button as request.

4-8. SPARE PARTS

1. The shaded and Δ -marked components are critical to safety.
Replace only with the same components as specified.

2. Replacement parts supplied from the Sony Parts Center will sometimes have a shape different from the original parts. These differences are for improved parts and/or engineering changes or standardization of genuine parts.
This manual's exploded views and electrical spare parts list indicate the part numbers of the standardized genuine parts at the present time. Regarding engineering part changes in our engineering department, refer to Sony service bulletins and service manual supplements.

S/N 13731 AND HIGHER

4-6. EXTENSION BOARD

The Amp chassis printed circuit boards listed can be serviced by using two kinds of Extension Boards. Simply insert the Extension Board into the Amp chassis and connect the circuit board to be serviced to the end of the Extension Board.

(NOTE)

Be sure to turn OFF power before inserting or removing the Extension Board or printed circuit boards.

Printed circuit board	Extension Board
SV-113 DM-55 (TBC-6)	EX-128
AU-83A AU-84A AU-85A BC-11 (TC-42)	EX-127

4-7. OPERATION OF THE UNIT WITHOUT INSTALLING THE CASSETTE-UP COMPARTMENT AND THE CASSETTE TAPE

The unit have the tape beginning and tape end sensors so that detect the tape top and tape end. For operating the unit without installing the Cassette-up Compartment and the cassette tape, disable the Tape Beginning Sensor and the Tape End Sensor.

1. Remove the Upper Case or Top Plate and Side Plate. (Refer to Section 4-1)
2. Short between TP10 (location No. F-1) and GND on the SY-102A Board with a shorting clip from the entrance of the Time Code Board.
Tape Beginning Sensor and the Tape End Sensor stop their operation.

(NOTE)

Never forget to remove the shorting clip after the check and adjustment.

If the unit is placed into the F FWD or REW mode without removing the shorting clip, the unit cannot detect the tape beginning or tape end. So the unit cannot operate the AUTO STOP operation. The tape and the unit are put into the dangerous situation.

3. Set the Bit7 of S101 (location No. C-1) on the SV-113 Board to ON. Set S301 (F-1) on the SV-113 Board to ON.

(NOTE)

After the check and adjustment, reset S101 and S301.

4. Turn the POWER ON.

The Threading Ring turns automatically, unit is put into the threading completion mode.

5. Press the button as request.

4-8. SPARE PARTS

1. The shaded and Δ -marked components are critical to safety.
Replace only with the same components as specified.

2. Replacement parts supplied from the Sony Parts Center will sometimes have a shape different from the original parts. These differences are for improved parts and/or engineering changes or standardization of genuine parts.
This manual's exploded views and electrical spare parts list indicate the part numbers of the standardized genuine parts at the present time. Regarding engineering part changes in our engineering department, refer to Sony service bulletins and service manual supplements.

4-9. FIXTURE

Part Number	Description	Application
J-6001-820-A	Drum Eccentricity Gauge (3)	Upper drum eccentricity adjustment
J-6001-830-A	Drum Eccentricity Gauge (2)	
J-6001-840-A	Drum Eccentricity Gauge (1)	
J-6001-930-A	Drum Eccentricity Gauge (4)	
J-6009-830-A	Flatness Plate	Stationary head slantness adjustment
J-6026-240-A	Adjustment driver	Electrical alignment
J-6130-010-A	Reel Table Height Check Base Gauge	Reel table height adjustment
J-6130-020-A	Reel Table Height Check Gauge	
J-6150-140-A	Eccentric Screwdriver (6 mm dia.)	Position adjustment
J-6153-020-A	Dihedral Adjustment Screwdriver	Video head dihedral adjustment
J-6153-720-A	Reel Motor Shaft Slantness Adjustment Gauge	Reel motor shaft slantness check and adjustment
J-6153-970-A	Hexagonal Screwdriver (1.5 mm)	Reel table height adjustment
J-6153-580-A	Pinch Lever Adjustment Tool	Pinch lever right angle adjustment
Y-2031-001-0	Cleaning Fluid	Cleaning
2-034-697-00	Cleaning Piece	
3-702-390-01	Eccentric Screwdriver (4 mm dia.)	Position adjustment
3-702-391-01	Eccentric Screwdriver (5 mm dia.)	Stationary head position adjustment
7-700-736-01	L-shaped Hexagonal Wrench (1.27 mm)	
7-700-736-05	L-shaped Hexagonal Wrench (1.5 mm)	
7-700-736-06	L-shaped Hexagonal Wrench (0.89 mm)	
7-723-902-00	Dental Mirror	For tape path adjustment
7-732-050-30	Tension Scale (100 g full scale)	Measurement of back tension and torque
7-732-050-40	Tension Scale (200 g full scale)	
7-732-050-50	Tension Scale (500 g full scale)	
8-960-012-83	Alignment Tape, RR5-3SB PAL	Conventional alignment tape
8-960-036-02	Alignment Tape, RR2-1SD PAL	Tracking, servo, audio and video adjustment
8-960-036-81	Alignment Tape, RR5-1SD PAL	
8-899-999-53	Torque Measurement Tape (100 mm dia.)	Measurement of torque
9-911-053-00	Thickness Gauge	For clearance check
Standard Products	Head Demagnetizer, HE-4	Degaussing of heads

SECTION 5 REPLACEMENT OF MAJOR PARTS

5-1. REPLACEMENT OF THE UPPER DRUM ASSEMBLY

- . The Rotary Video Heads cannot be replaced individually. The entire Upper Drum Assembly should be replaced when any of these heads fails.

Tool: Drum eccentricity gauge (1)
Drum eccentricity gauge (2)
Drum eccentricity gauge (3)
Drum eccentricity gauge (4)

Replacement procedure:

- (1) Disconnect the connector of the brush from the Slip Ring Block. Remove the Brush Assembly from the drum after removing the two fixing screws.
- (2) Unsolder the eight leads from the video head at the printed circuit board. Remove the two fixing screws and then remove the Upper Drum Assembly from the Head Drum Assembly.
- (3) Clean the matching surfaces of the flange and new Upper Drum Assembly with a cloth moistened with cleaning fluid. (If there is a spacer between the drum and the flange, it should be left on the flange. If the spacer is lost, correct interchangeability cannot be obtained.)
- (4) Place the Upper Drum Assembly so that the side with the three red leads matches side "B" of the printed circuit board as shown in the figure. Thread the two fixing screws snugly but do not tighten them.

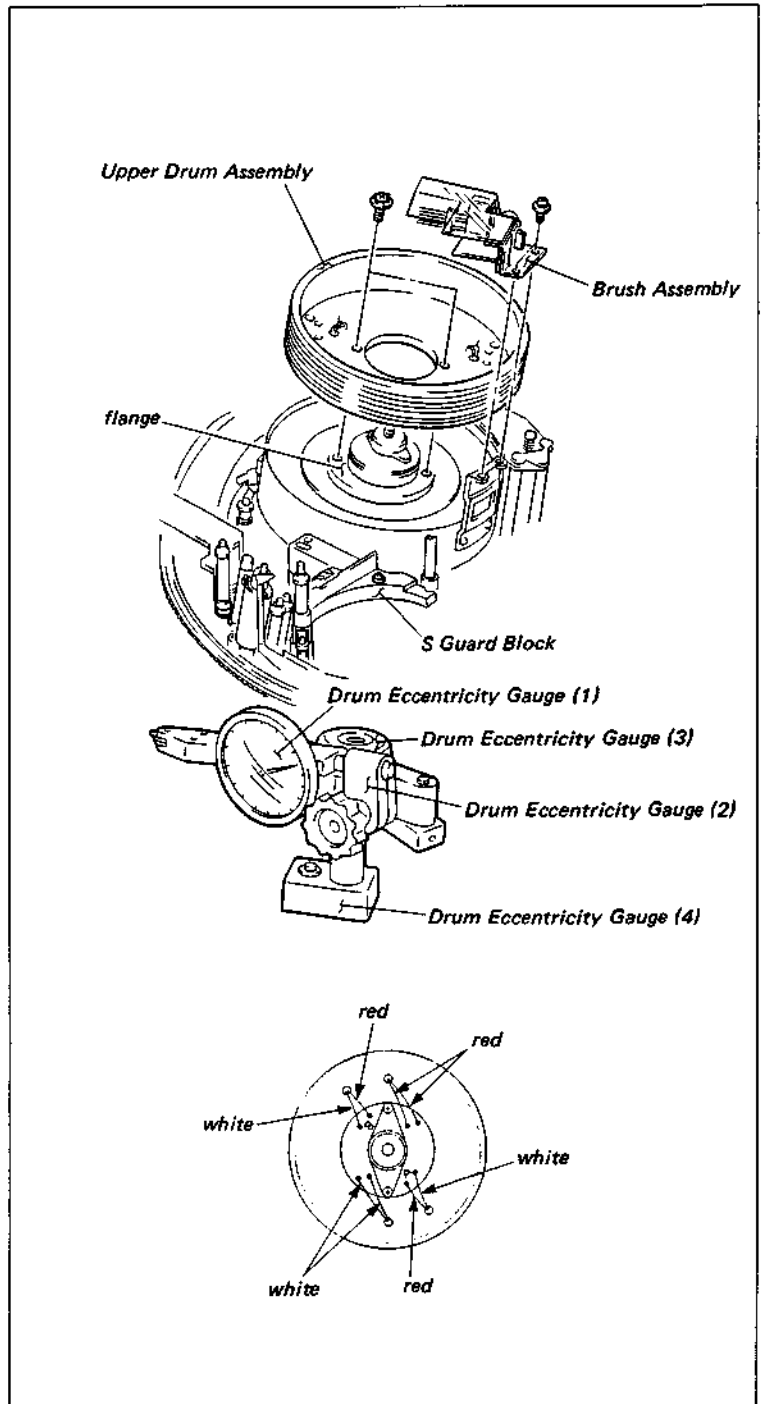

Adjustment procedure:

- (1) Remove the S Guard Block. (The connector at the bottom of the S Guard is inserted into the connector on the chassis.)
- (2) Assemble the Drum Eccentricity Gauges (1), (2), (3) and (4) as shown in the figure. Set the assembled gauges on the unit so that the probe tip is positioned at a point about 5 mm from the top edge of the Upper Drum.
- (3) Turn the Upper Drum slowly in the clockwise direction and check that the gauge deflection is within 5 microns during one complete revolution of the Upper Drum. If it is within specification, proceed with the Step (5). If it is not, perform Step (4).
- (4) Tap the inside of the Upper Drum with a nylon hammer or a screwdriver handle until the gauge deflection remains within 5 microns.
- (5) After the adjustment, alternately tighten the two fixing screws of the Upper Drum. (Tightening torque: 14 to 16 kg-cm)
- (6) After tightening the screws, check that the gauge deflection is within 5 microns.
- (7) Solder the eight leads from the video heads to the printed circuit board.
- (8) Remove the brush cover from the Brush Assembly.
- (9) Install the Brush Assembly. Check that the position of the brush is as shown in the figure.
- (10) Install the brush cover and connect the connector to the brush.
- (11) Install the S Guard Block. (Insert the connector on the bottom of the S Guard Block securely into the connector on the chassis.)
- (12) After replacement, adjust as described in Section 5-12.

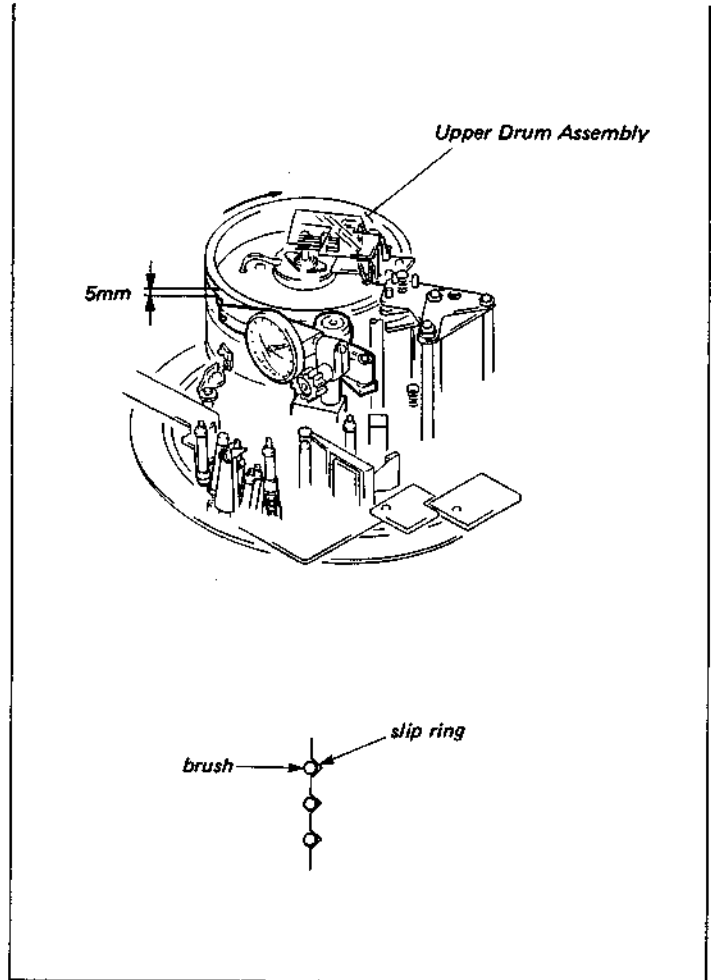

5-2. REPLACEMENT OF THE DRUM ASSEMBLY

Replacement procedure:

- (1) Disconnect the connector from the brush of the Slip Ring Block. Remove the Brush Assembly from the drum after removing the two fixing screws.
- (2) Open the SY-102A Board after removing the three fixing screws.
- (3) Disconnect the three connectors of the drum assembly from the back of the unit.
- (4) Remove the three fixing screws which hold the drum.
- (5) Install the drum on the base while turning the drum assembly in the counterclockwise direction when viewed from the top of the unit.
- (6) Connect the three connectors.
- (7) Install the SY-102A Board.
- (8) Install the Brush Assembly. Check that the position of the brush is as shown in the figure.
- (9) Adjust as described in Section 5-12.

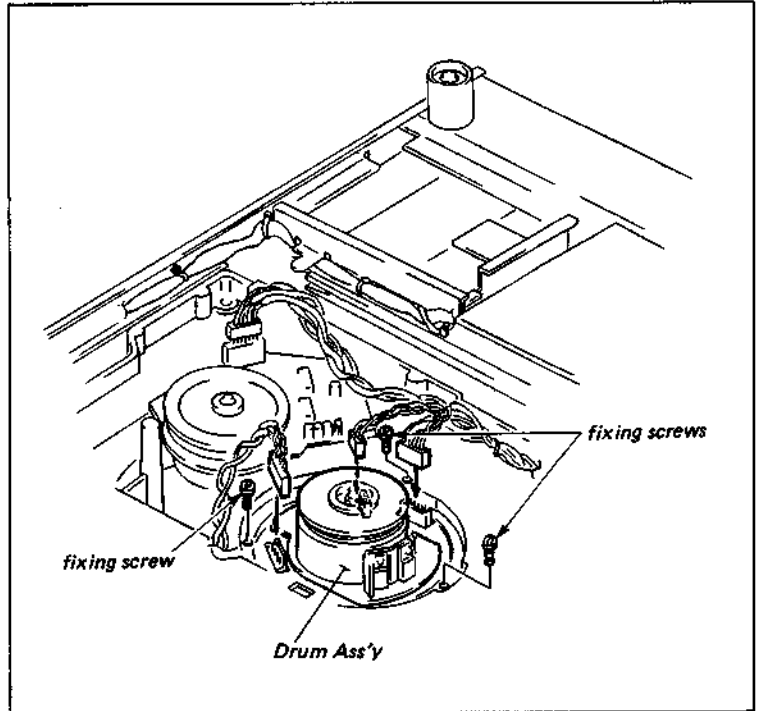

5-3. REPLACEMENT OF THE CAPSTAN MOTOR

Replacement procedure:

- (1) Open the SY-102A Board after removing the three fixing screws.
- (2) Disconnect the connector of the capstan motor from the back of the unit.
- (3) From the top of the unit, remove the three fixing screws and replace the capstan motor with a new one.
- (4) Position the new capstan motor and thread the three fixing screws snugly but do not tighten them.
- (5) Tighten the three fixing screws while turning the Capstan Motor in the direction of the arrow.
- (6) Connect the connector.
- (7) Install the SY-102A Board.
- (8) Adjust as described in Section 5-12.

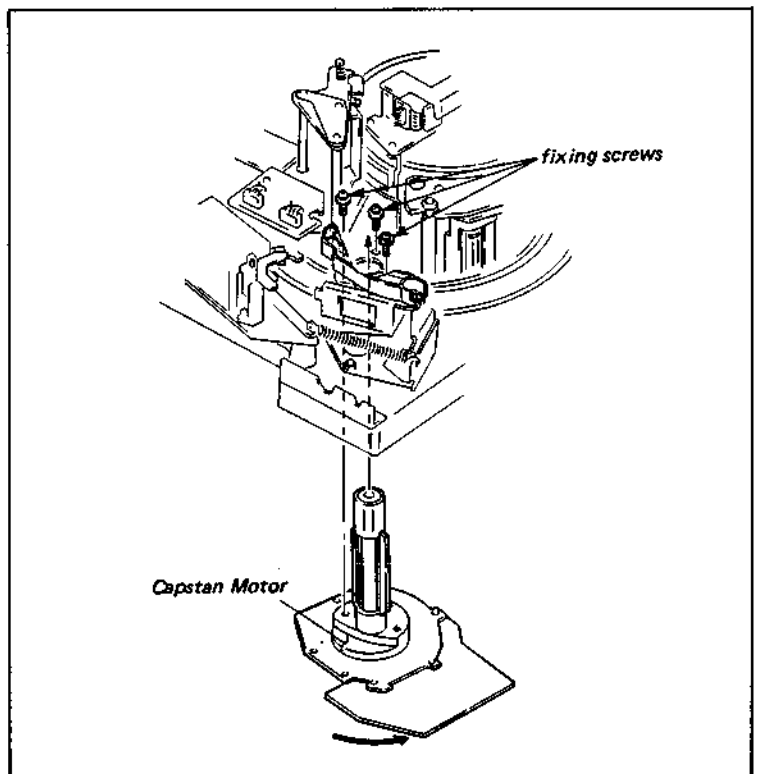

5-4. REPLACEMENT OF THE REEL MOTOR

Replacement procedure:

- (1) Loosen the two set screws in the reel table and remove the reel table and the spring from the reel shaft as shown in the figure.
- (2) Open the SY-102A Board after removing the three fixing screws.
- (3) Disconnect the connector of the printed circuit board of the reel motor from the back of the unit.
- (4) Remove the reel motor from the chassis after removing the three fixing screws from the top of the unit.
- (5) Remove the fixing screw of the M Band and then remove the M Band and M PC Board Holder from the motor.
- (6) Unsolder the printed circuit board from the reel motor.
- (7) Replace the reel motor. Remove the spacer from between the reel motor and chassis. This spacer is used for Section 6-1-3, Reel Motor Shaft Slantness Adjustment.
- (8) Adjust as described in Section 5-12.

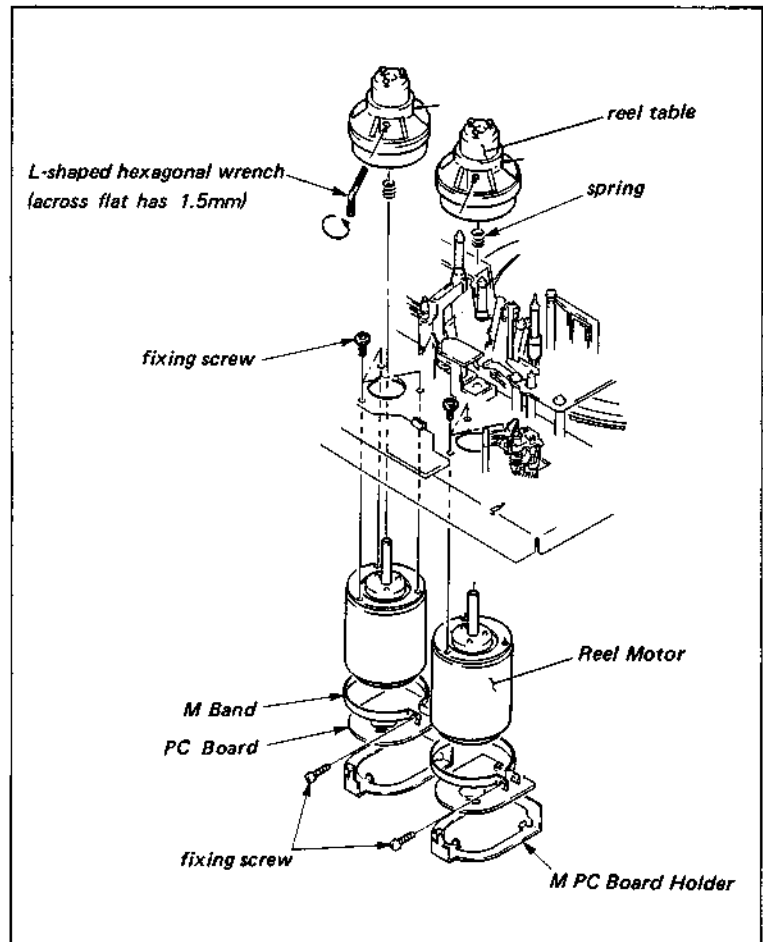

5-5. REPLACEMENT OF THE HEAD

5-5-1. Replacement of the Audio/CTL Head

Replacement procedure:

- (1) Remove the Audio/CTL Head Block from the unit after removing the three fixing screws as shown in the figure.
- (2) Remove the Audio/CTL Head and the shield case (F and B) after removing the two fixing screws as shown in the figure.
- (3) Remove the two fixing screws from the shield case.
- (4) Unsolder the ten leads from the printed circuit board and remove the DUS-92 Board from the head.
- (5) Replace the head with a new one and solder the leads to the DUS-92 Board as shown in the figure.
- (6) Perform steps (1) to (3) in reverse order.
- (7) Adjust as described in Section 5-12.

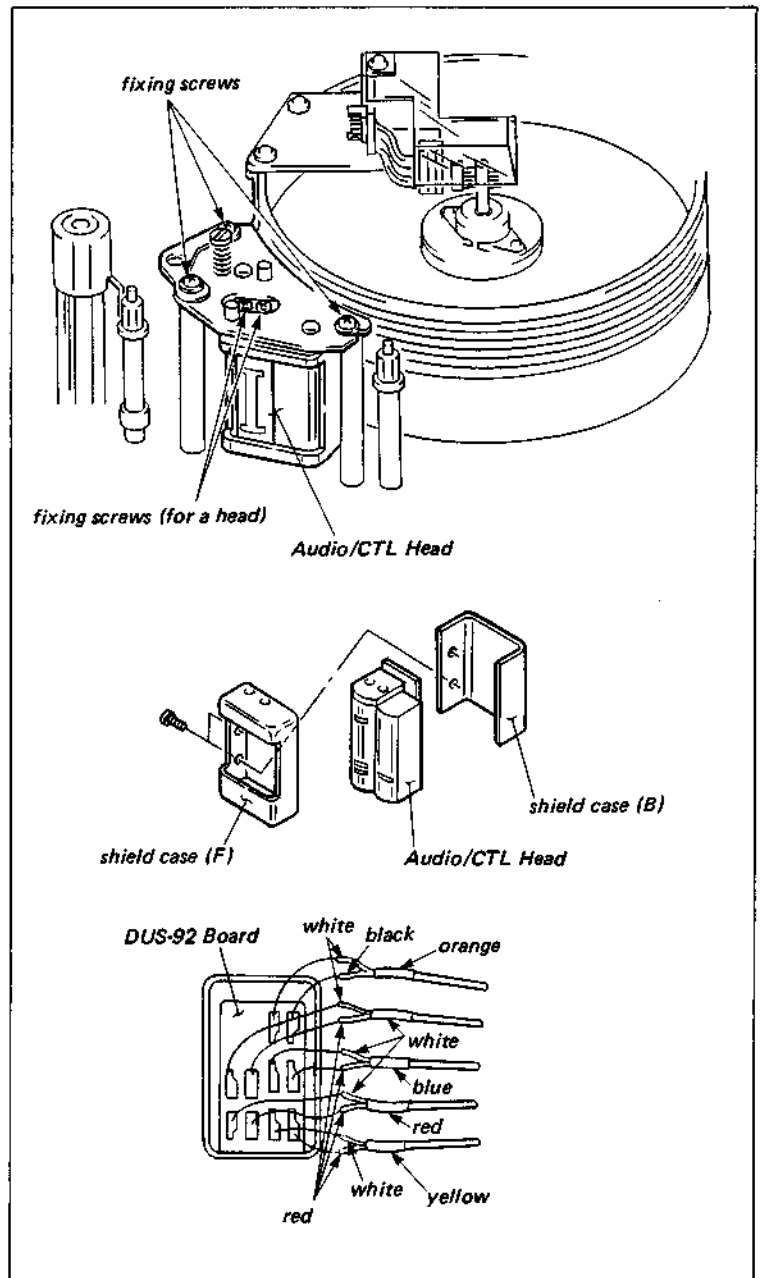

5-5-2. Replacement of the Time Code Head

Replacement procedure:

- (1) Remove the Time Code Head Block from the unit after removing the three fixing screws.
- (2) Remove the cap screw which holds the Time Code Head.
- (3) Unsolder the shield board from the HN-84 Board.
- (4) Unsolder the HN-84 Board from the Time Code Head and replace the head with a new one.
- (5) Solder the HN-84 Board to the Time Code Head and perform steps (1) to (3) in reverse order.

NOTE:

- (i) When the Time Code Head is replaced, be sure that the Drum Assembly is not damaged.
- (6) Adjust as described in Section 5-12.

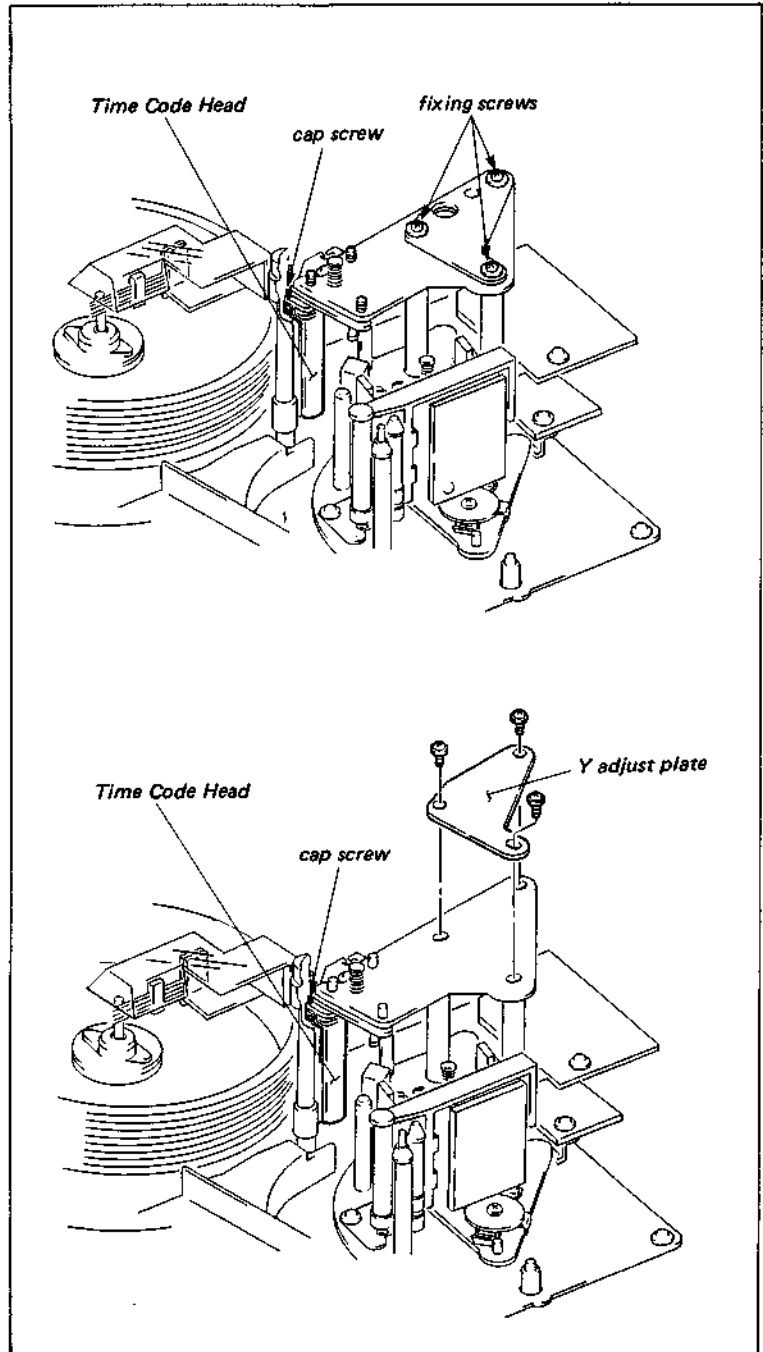

5-5-3. Replacement of the Full Erase Head

Replacement procedure:

- (1) Unsolder the two leads from the Full Erase Head.
- (2) Remove the Full Erase Head Block from the unit after removing the two fixing screws.
- (3) Remove the Full Erase Head from the bracket after removing the two fixing screws.
- (4) Replace the head with a new one and perform steps (1) to (2) in reverse order.
- (5) Adjust as described in the Section 5-12.

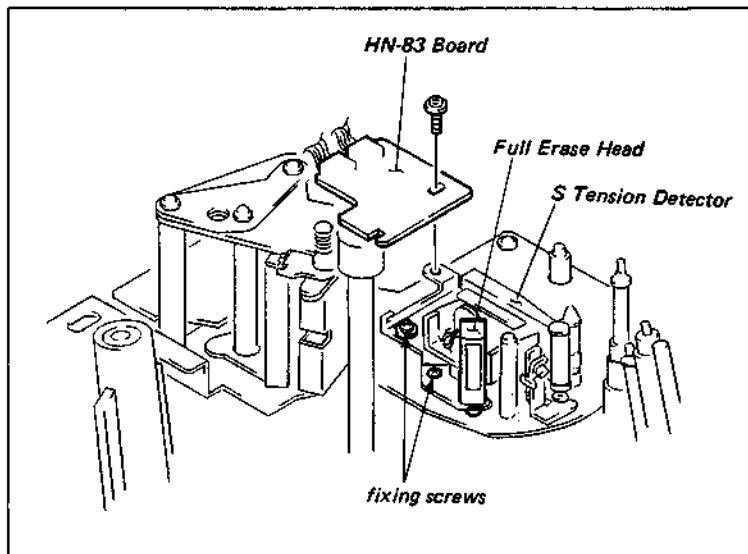

5-6. REPLACEMENT OF THE TENSION DETECTOR BLOCK

5-6-1. Replacement of the S Tension Detector

Replacement procedure:

- (1) Disconnect CN410 on the PD-37 Board.
- (2) Remove the S Tension Detector Block from the unit after removing the fixing screw.
- (3) Check that the adjustment screws of the new detector meet the required specification as shown in the figure.
- (4) Install the S Tension Detector Block to the unit. (Tightening torque: 5 to 7 kg-cm)
- (5) Adjust as described in Section 5-12.

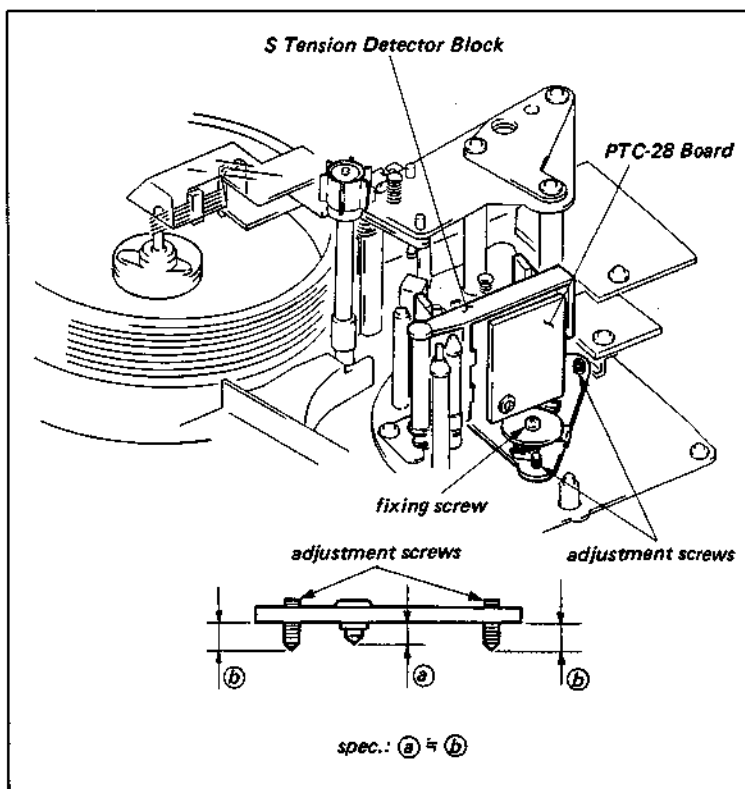

5-6-2. Replacement of the T Tension Detetector

Tool: L-shaped hexagonal wrench
(across flat has 1.5 mm)

Replacement procedure:

- (1) Disconnect CN234 on the MB-139 Board from the back of the unit.
- (2) Remove the fixing screw from the T Tension Detector.
- (3) Remove the TRC Detector Block.
- (4) Loosen the set screw of the Cassette Guide Block and remove the Cassette Holder.
- (5) Remove the T Tension Regulator Arm and the T Tension Detector Block from the shaft. (Note that there is a spring and a collar as shown in the figure.)
- (6) Replace the defective parts of the detector block with a new one.
- (7) Join the T Tension Detector Block with the T Tension Regulator Arm and put the assembly on the shaft. Be sure that the shaft of the tension detector is between the two Leaf Springs as shown in the figure.
- (8) Put the collar, spring and the Cassette Holder on the shaft.
- (9) Tighten the fixing screw and install the T Tension Detector to the unit.
- (10) Connect CN234 on the MB-139 Board from the back of the unit.
- (11) Position the notch of the TRC Detector Block in the groove of the Cassette Holder. While pushing the TRC Detector Block in the direction of the arrow, install it on the unit.
- (12) Adjust as described in Section 5-12.

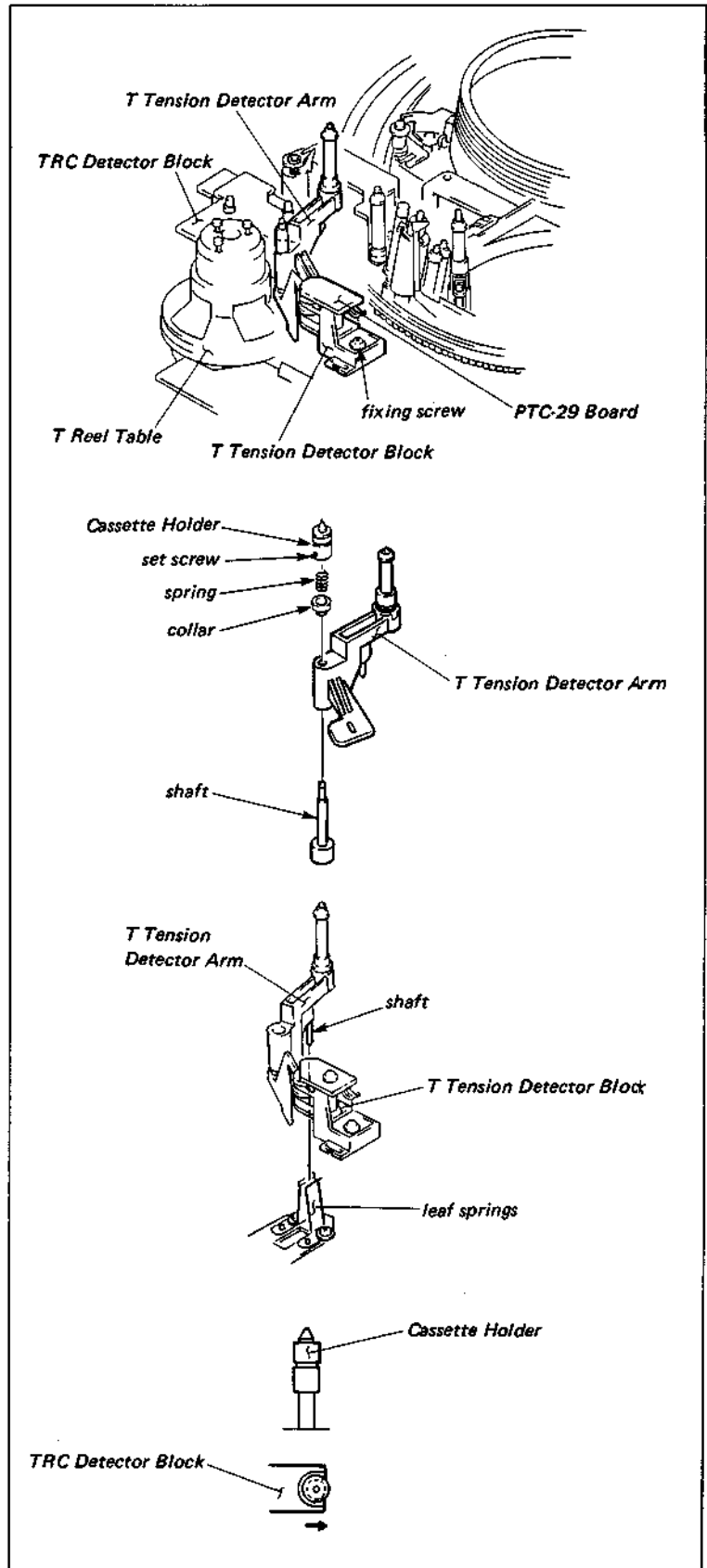

5-6-3. Replacement of the CDS of the S Tension Detector

Replacement procedure:

- (1) Remove the PTC-28 Board from the S Tension Detector Block.
- (2) Replace the CdS with a new one.
- (3) Adjust as described in Section 5-12.

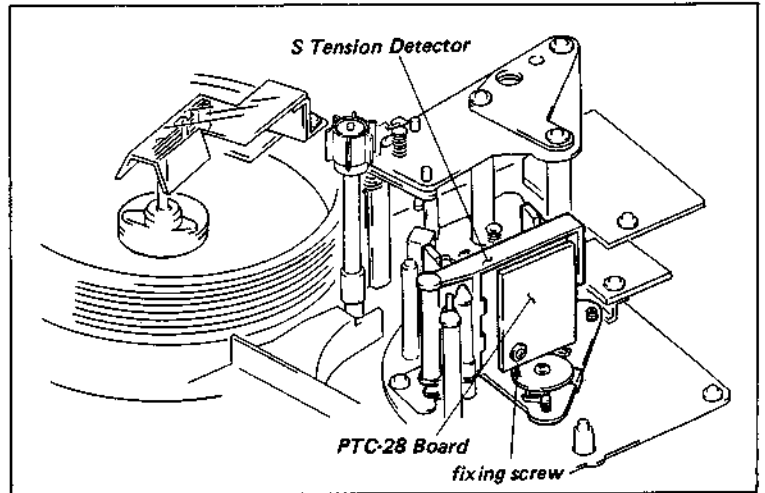

5-6-4. Replacement of the CDS of the T Tension Detector

Replacement procedure:

- (1) Remove the PTC-29 Board from the T Tension Detector Block.
- (2) Replace the CdS with a new one.
- (3) Adjust as described in Section 5-12.

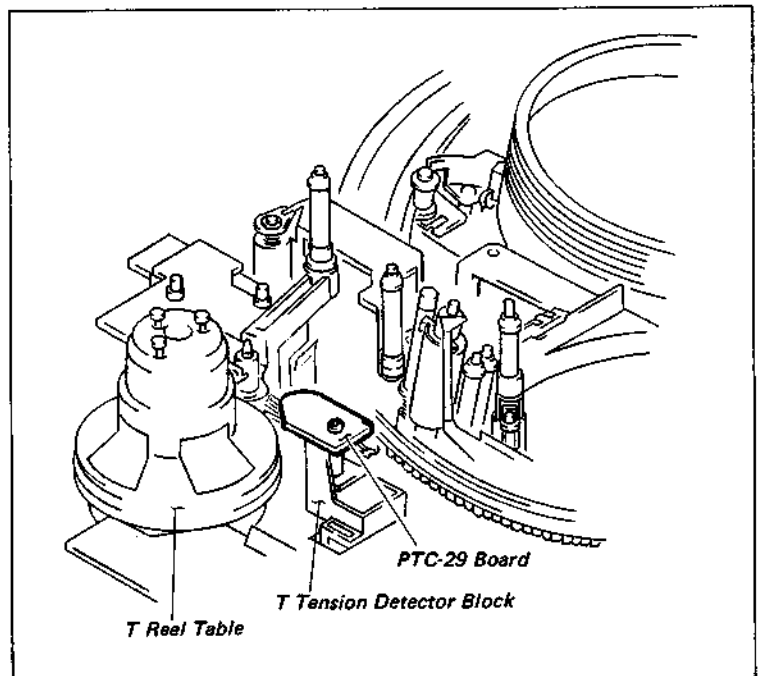

5-7. REPLACEMENT OF THE S DRAWER ROLLER

Tool: Sony grease

Replacement procedure:

- (1) Put the unit into the EJECT mode without a cassette tape.
- (2) Turn the pulley of the Gear Box Block until the S Drawer Roller is between the S Tension Roller and TG-2.
- (3) Remove the S Drawer Roller from the shaft while pushing the spring holder (red) in the direction of the arrow.
- (4) Smear a little Sony Grease in the notch at the bottom of the new S Drawer Roller.
- (5) While pushing the spring holder in the direction of the arrow, slide the new S Drawer Roller down the shaft until the S Drawer Roller locks to the shaft.
- (6) Adjust as described in Section 5-12.

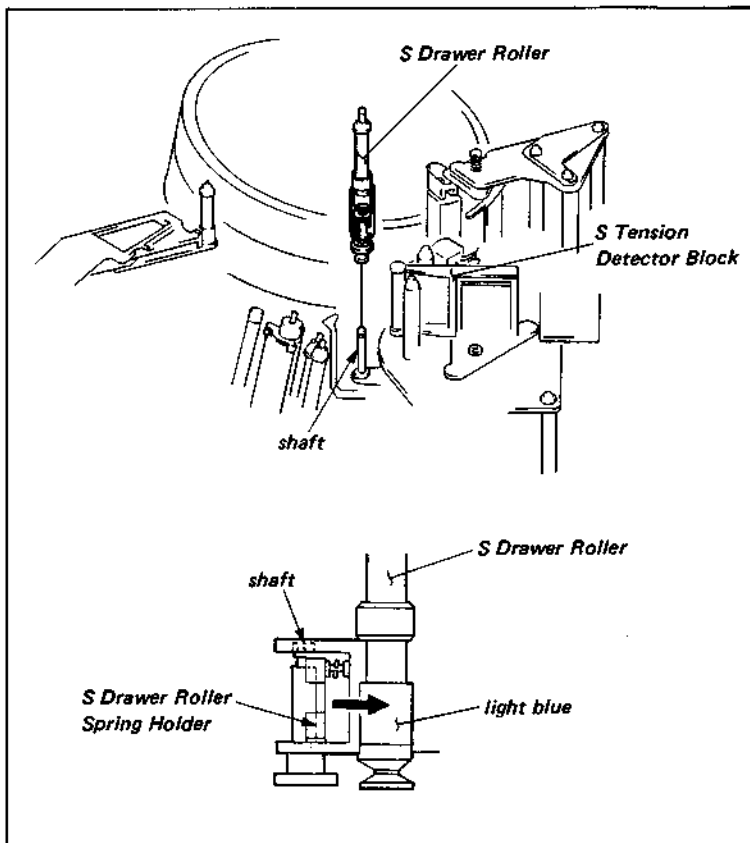

5-8. REPLACEMENT OF THE THREADING RING SYSTEM

5-8-1. Replacement of the Threading Ring

Replacement procedure:

- (1) Remove the E Head Base Block from the unit after removing the four fixing screws.
- (2) Remove the S Guard Assembly and the FR Detector from the unit.
- (3) Loosen the two fixing screws from the Threading Gear Block and remove it from the Threading Ring.
- (4) Loosen the fixing screw and then move the Ring Roller (C) and the P Offset Prevention Cam in the direction of the arrow.
- (5) Remove the Threading Ring from the unit and replace it with a new one.
- (6) Perform steps (1) to (4) in reverse order.
- (7) Adjust as described in Section 5-12.

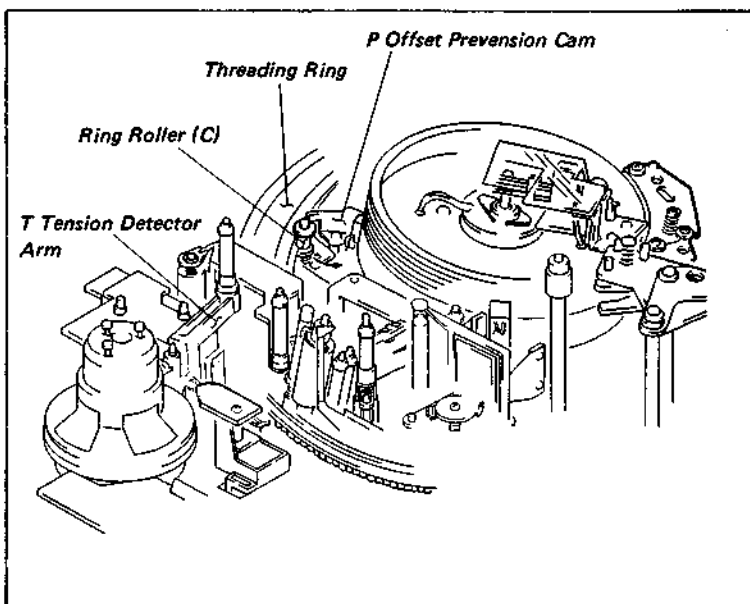

5-8-2. Replacement / Adjustment of the TG-5 and TG-6

. There are three tape guides on the Threading Ring. The replacement procedure for two of the guides (TG-5 and TG-6) is different from that of the Threading Guide.

Tool: L-shaped hexagonal wrench
(across flat has 1.27 mm)

Slide vernier callipers or equivalent

Replacement procedure:

- (1) Loosen the set screw in the Threading Ring boss. Remove the Tape Guide Block from the Threading Ring.
- (2) Replace the tape guide with a new one.
- (3) Assemble the guide roller as shown in the figure. Tighten the set screw of the boss so that the clearance between the upper flange and the boss to meets the required specification. Check that the guide roller turns smoothly.
- (4) Insert a cassette tape and put the unit into the PLAY mode. Check that the tape runs along the upper flange of the new tape guide without curling.
- (5) Adjust as described in Section 5-12.

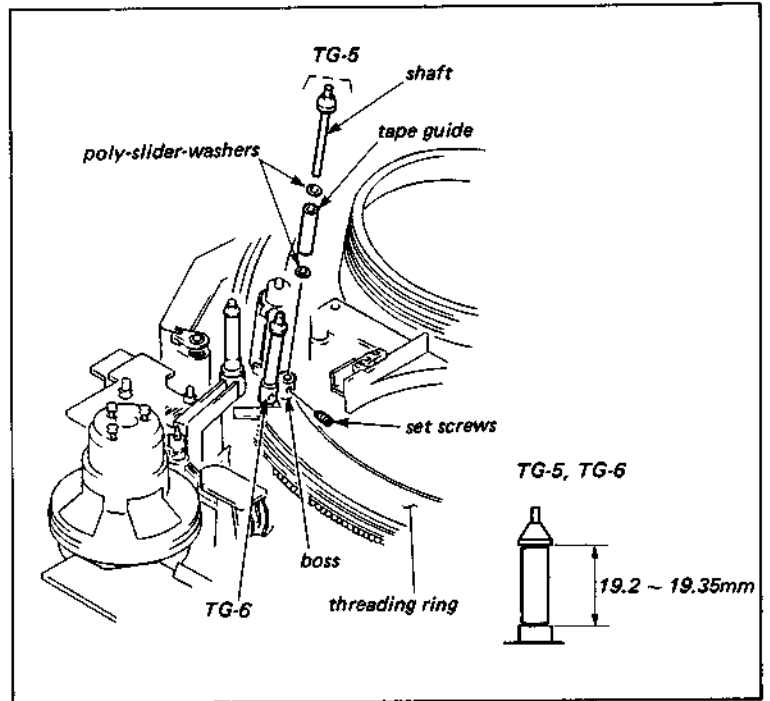

5-8-3. Replacement / Adjustment of the Threading Roller

Replacement procedure:

- (1) Loosen the set screw in the upper flange of the Threading Roller. Remove the Threading Roller by turning the upper flange.
- (2) Replace the guide with a new one. Be sure that the upper and lower sides of the Threading Guide match the figure (beveled end up).
- (3) Tighten the set screw at the top of the Threading Roller.
- (4) Adjust as described in Section 5-12.

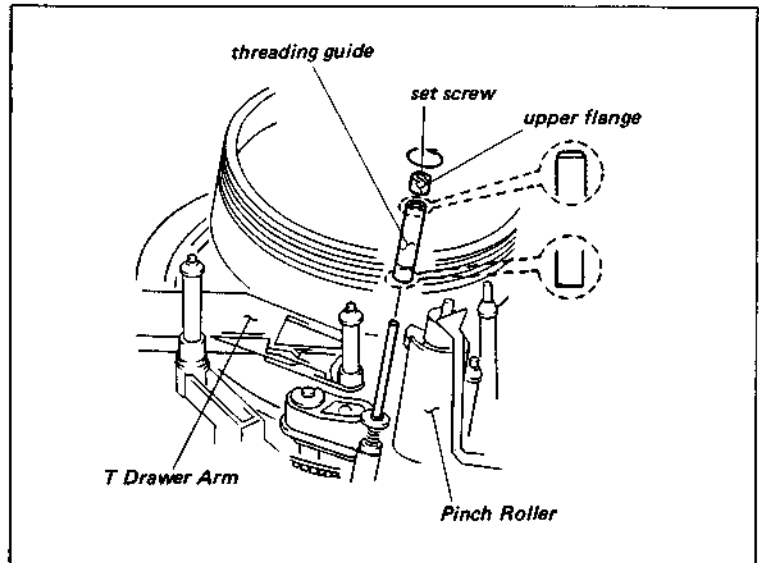

5-8-4. Replacement of the Pinch Roller

Replacement procedure:

- (1) Turn the pulley of the Gear Box until the S Drawer Roller is in front of the Full Erase Head.
- (2) Remove the Pinch Arm Assembly from the Threading Ring after removing the E ring.
- (3) Replace the Pinch Roller Assembly with a new one.
- (4) Install the Pinch Roller Assembly on the Threading Ring as shown in the figure.
- (5) Adjust as described in Section 5-12.

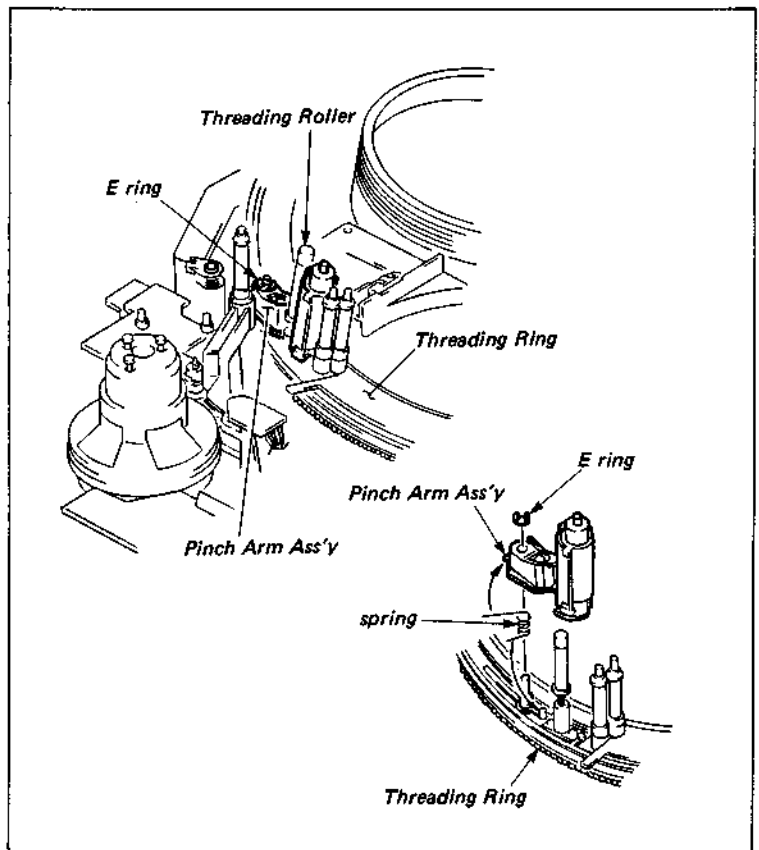

5-9. REPLACEMENT OF THE THREADING GEAR BOX SYSTEM

5-9-1. Replacement of the Threading Gear Box

Replacement procedure:

- (1) Put the unit into the EJECT mode and turn the power OFF.
- (2) Remove the T Tape Sensor from the gear box after removing the fixing screw.
- (3) Remove the two fixing screws of the gear box after turning the pulley 1 revolution in the direction of arrow A. Move the gear box in the direction of arrow B and remove it from the unit.
- (4) Remove the harness from the clasper and disconnect CN511 from the HN-80 Board.
- (5) Replace the gear box with a new one.
- (6) Perform steps (3) and (4) in reverse order.
- (7) Put the gear box on the chassis and thread the two fixing screws snugly but do not tighten them. Tighten the two fixing screws of the gear box after meshing the Threading Ring to the gear.
- (8) Adjust as described in Section 5-12.

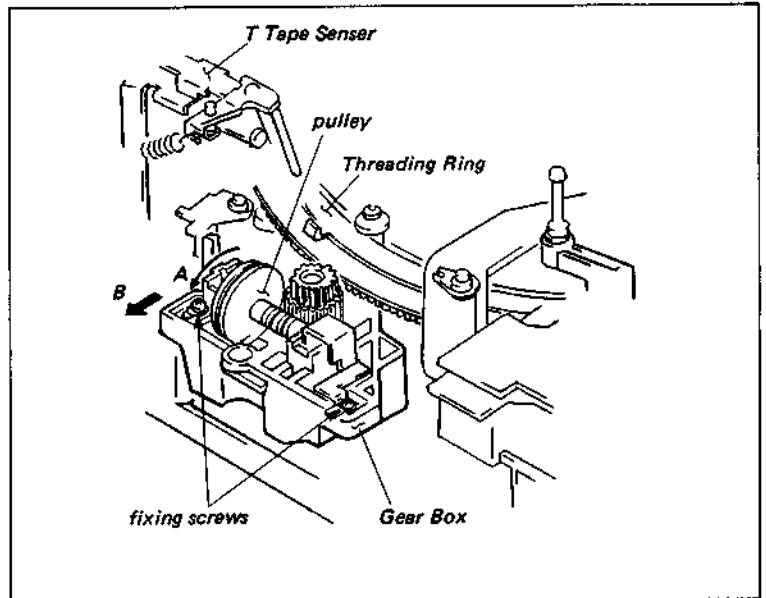

5-9-2. Replacement of the Threading Motor

Tool: L-shaped hexagonal wrench
(across flat has 1.5 mm)

Replacement procedure:

- (1) Perform steps (1) to (4) of Section 5-9-1, Replacement of the Threading Gear Box.
- (2) Remove the gear after removing the stop ring.
- (3) Remove the belt from the motor pulley. Remove the plate from the frame after removing the fixing screw.
- (4) Remove the pulley while pushing the hook in the direction of the arrow as shown in the figure.
- (5) Remove the motor block from the frame after removing the two fixing screws.
- (6) Loosen the set screw and remove the motor pulley.
- (7) Remove the motor from the motor bracket after removing the two fixing screws.
- (8) Remove the shield case and unsolder the LM-13 Board. Replace the motor with a new one.
- (9) The pole of the motor is as shown in the figure. Solder the plus terminal of the motor to the plus pad of the LM-13 Board.
- (10) Install the shield case to the motor.
- (11) Install the motor to the frame as shown in the figure. Perform steps (4) to (6) in reverse order. Check that the clearance between the motor pulley and the bracket meets the required specification.
- (12) Hook the belt to the pulley and install the pulley on the frame. Be sure that the orientation of the notch of the pulley shaft is as shown in the figure.
- (13) Hook the belt to the motor pulley. Check that the belt is not twisted.
- (14) Check as described in Section 5-12.

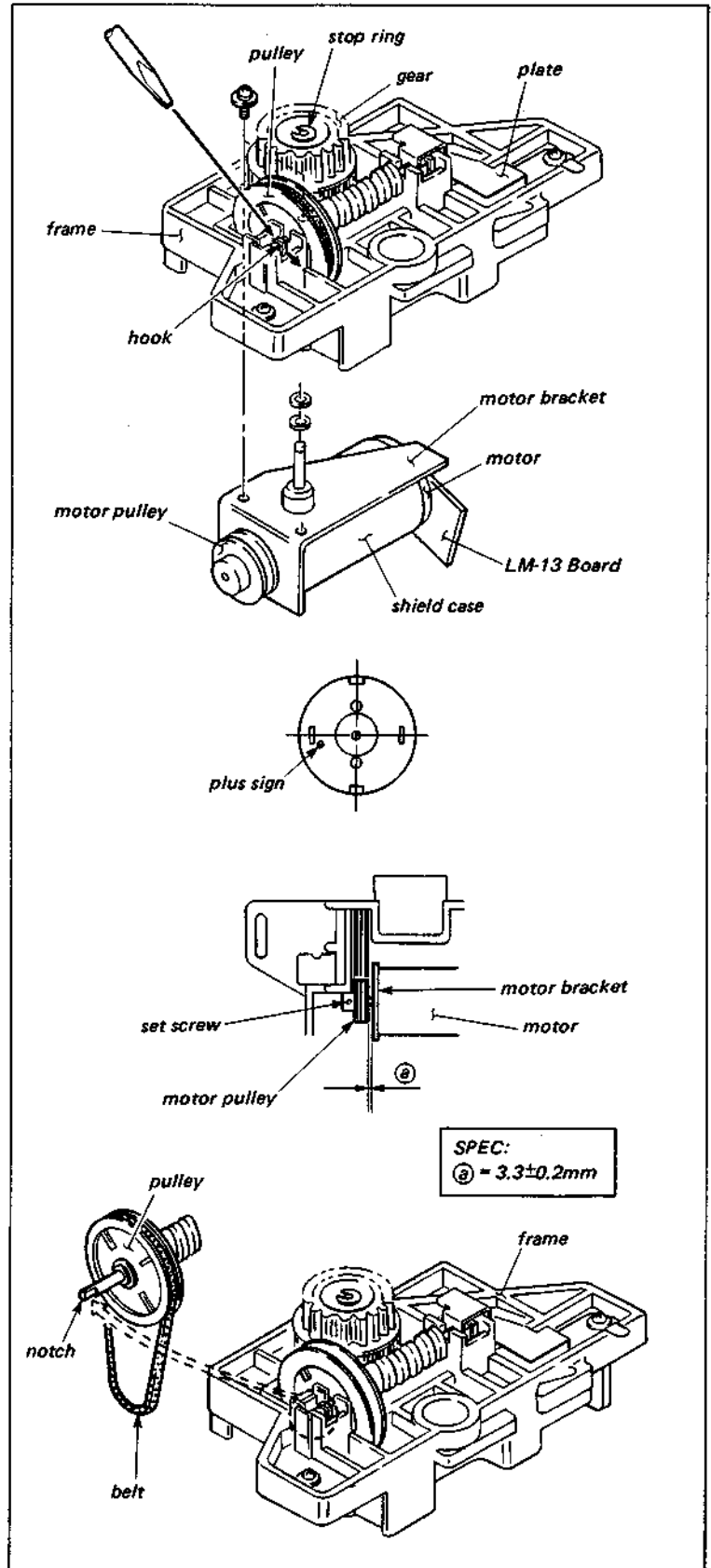

5-9-3. Replacement of the Threading Belt

Replacement procedure:

- (1) Perform steps (1) to (3) in Section 5-9-2, Replacement of the Threading Motor.
- (2) Clean the new belt and the groove of the pulley with a cloth moistened with cleaning fluid.
- (3) Hook the belt to the pulley and install them to the frame. Be sure that the orientation of the notch of the pulley shaft is as shown in the figure.
- (4) Install the plate to the frame and hook the belt to the Motor pulley. Check that the belt is not twisted.
- (5) Check as described in Section 5-12.

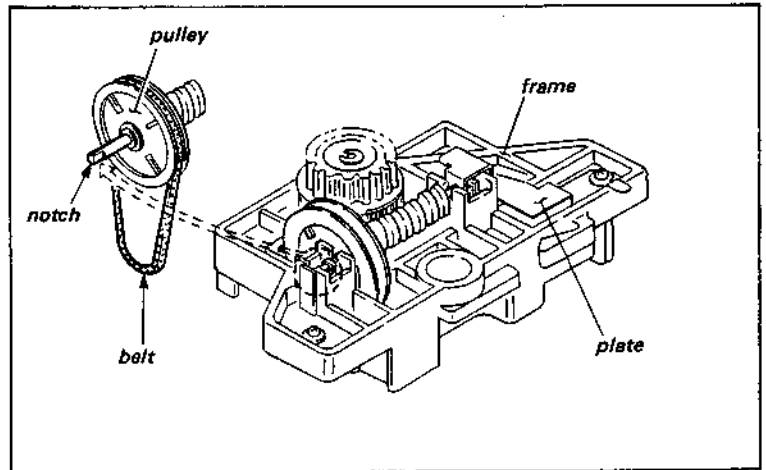

5-10. REPLACEMENT OF THE REEL TABLE ROTATION DETECTOR BLOCK

Mode: EJECT completion mode

Replacement procedure:

- (1) Remove the SE-48 Board from the DME stand after removing the two fixing screws.
- (2) Remove the DME holder from the SE-48 Board.
- (3) Replace the DME with a new one. When the DME is mounted, note that the leads of the DME are not bent.
- (4) Install the DME holder to the SE-48 Board and install them to the DME stand with two fixing screws.
- (5) Adjust as described in Section 5-12.

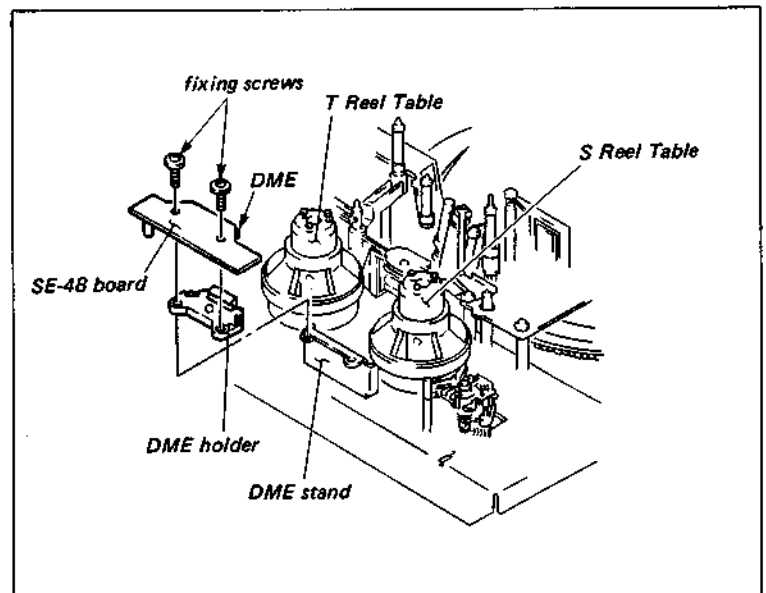

5-11. REPLACEMENT OF THE PINCH SOLENOID

Replacement procedure:

- (1) Open the RP-30A Board after removing the two fixing screws.
- (2) Disconnect CN407 from the PD-37 Board.
- (3) Remove the E ring of the Joint Plate and the Pre-set Adjustment Link.
- (4) Remove the Pinch Solenoid Block from the chassis after removing the two fixing screws.
- (5) Remove the two fixing screws and replace the Pinch Solenoid with a new one.
- (6) Perform steps (1) to (3) in reverse order.
- (7) Adjust as described in Section 5-12.

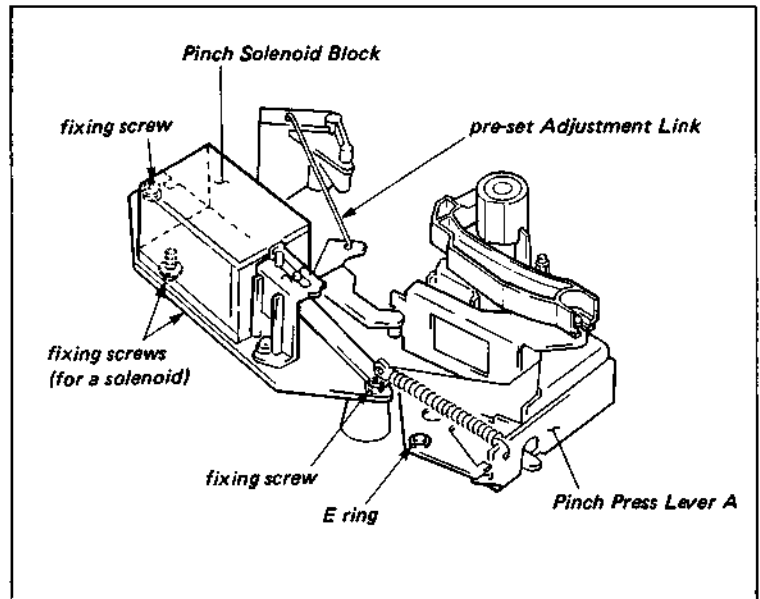

5-12. ITEMS TO BE ADJUSTED AFTER MAIN PARTS REPLACEMENT

(Numbers in parentheses refer to Section Nos.)

Replacement of the Threading Ring

Threading Ring Rotation Adjustment (6-5-1) → Gear Box Installing Position Adjustment (6-5-2) →
FR Detector Installing Position Adjustment (6-5-4) → Pinch Roller Self Alignment Adjustment (6-5-3) →
Pinch Lever Preset Adjustment (6-6-1) → Pinch Roller Preset Adjustment (6-6-2) → Sub Brake
Release Adjustment (7-3-2) → Leaf Spring Position Adjustment (6-12) → FF/REW Mode Tape Path
Adjustment (8-4) → FWD X 5 / REV X 5 Serch Mode Tape Path Adjustment (8-5) → PLAY Mode Tape
Path Adjustment (1) (8-2) → PLAY Mode Tape Path Adjustment (2) (8-3) → T Correction Guide
Slantness Adjustment (8-1) → Video Tracking Adjustment (check) (8-9-1) → Audio/CTL Head
Position Adjustment (8-9-5) → Time Code Head Position Adjustment (8-9-7)

Replacement of the Pinch Roller

Pinch Roller Self Alignment Adjustment (6-5-3) → Pinch Roller Preset Adjustment (6-6-2) → PLAY
Mode Tape Path Adjustment (2) (8-3) → FF/REW Mode Tape Path Adjustment (8-4) → FWD X 5 /
REV X 5 Serch Mode Tape Path Adjustment (8-5) → Video Tracking Adjustment (check) (8-9-1)

Replacement of the Reel Table

Reel Table Height Adjustment (6-1-2) → Reel Table Rotation Detector Block Position Adjustment
(6-10) → S Brake Torque Adjustment (7-1) or T Brake Torque Adjustment (7-2) → Sub Brake
Adjustment (7-3) (Only when the S Reel Table is replaced.) → Video Tracking Adjustment (check) (8-9-1)

Replacement of the Capstan Motor

Pinch Solenoid Block Position Adjustment (6-6-4) → PLAY Mode Tape Path Adjustment (1) (8-2) →
PLAY Mode Tape Path Adjustment (2) (8-3) → FF/REW Mode Tape Path Adjustment (8-4) → FWD X 5 /
REV X 5 Search Mode Tape Path Adjustment (8-5) → Video Tracking Adjustment (8-9-1) → Capstan Servo
System Adjustment

Replacement of the Threading Gear Box, Threading Motor and the Threading Belt

Gear Box Installing Position Adjustment (6-5-2)

Replacement of the Reel Motor

Reel Motor Shaft Slantness Adjustment (6-1-3) → Reel Table Height Adjustment (6-1-2) →
Brake Solenoid Position Adjustment (6-9) (6-9-1 or 6-9-2) → Reel Table Rotation Detector Block
Position Adjustment (6-10) → S Reel Motor Current Sensitive Adjustment (7-4-1) or T Reel Motor
Current Sensitive Adjustment (7-4-2) → S Brake Torque Adjustment (7-1) or T Brake Torque Adjustment (7-2)
→ Sub Brake Adjustment (7-3) (Only when the S Reel Motor is replaced.) → FWD Back Tension
Adjustment (7-5) → Video Tracking Adjustment (check) (8-9-1) → Reel Servo System Adjustment

Replacement of the Audio / CTL Head

T Tape Senser Position Adjustment (6-7) → Tracking Adjustment (8-9) → Audio System Adjustment

Replacement of the Drum Assembly

FWD Back Tension Adjustment (7-5) → Tracking Adjustment (8-9) → Slip Ring Block Brush Position
Adjustment (6-13) → Video Head Dihedral Adjustment (8-10) → Switching Position Adjustment
(8-9-8) → Drum Phase Adjustment (8-9-9) → Servo System Adjustment → Video System Adjustment

Replacement of the Upper Drum

Upper Drum Eccentricity Adjustment → FWD Back Tension Adjustment (7-5) → Tracking Adjustment (8-9)
Slip Ring Block Brush Position Adjustment (6-13) → Video Head Dihedral Adjustment (8-10) →
Switching Position Adjustment (8-9-8) → Drum Phase Adjustment (8-9-9) → Video System Adjustment

Replacement of the Reel Table Rotation Detector Block

Reel Table Rotation Detector Block Position Adjustment (6-10)

Replacement of the S Drawer Roller

S Drawer Roller Block Limiter Adjustment (6-8) → Video Tracking Adjustment (check) (8-9-1)

Replacement of the T Tension Detector CdS

T Tension Detector Operating Point Adjustment (6-4-3) → Reel Servo Adjustment

Replacement of the S Tension Detector CdS

S Tension Detector Operating Point Adjustment (6-3-2) → Reel Servo Adjustment

Replacement of the Full Erase Head

Full Erase Head Zenith Adjustment (8-6) → Video Tracking Adjustment (check) (8-9-1)

Replacement of the Time Code Head

Time Code Head Adjustment (8-8) → Tracking Adjustment (8-9) → Time Code System Adjustment

Replacement of the Threading Guide

PLAY Mode Tape Path Adjustment (2) (8-3) → FF/REW Mode Tape Path Adjustment (8-4) →
FWD X 5 / REV X 5 Search Mode Tape Path Adjustment (8-5)

Replacement of the TG-5 and TG-6

T Correction Guide Slatness Adjustment (8-1) → PLAY Mode Tape Path Adjustment (1) (8-2)
→ PLAY Mode Tape Path Adjustment (2) (8-3)

Replacement of the T Tension Detector

T Tension Detector Adjustment (6-4) → Video Tracking Adjustment (check) (8-9-1) → Reel Servo Adjustment

Replacement of the S Tension Detector

S Tension Detector Adjustment (6-3) → Video Tracking Adjustment (check) (8-9-1) → Reel Servo Adjustment

Replacement of the Pinch Solenoid

Pinch Solenoid Installing Position Adjustment (6-6-3) → Pinch Lever Preset Adjustment (6-6-1)
→ Pinch Roller Self Alignment Adjustment (6-5-3) → Pinch Roller Preset Adjustment (6-6-2)
→ Pinch Solenoid Block Position Adjustment (6-6-4)



SECTION 6 LINK AND DRIVE SYSTEM ALIGNMENT

S/N UP TO 13730

ALIGNMENT INFORMATION

1. Operation of the unit without installing the cassette-up compartment and tape

- (1) Short between TP10 and E1 of the SY-102A Board with a shorting clip from the entrance of the Time Code Board.
(The clip will disable the Tape Beginning and Tape End Sensors.)

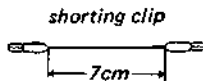

- (2) Set the Bit 7 of S201 on the SV-88A Board to ON and check that the Bit 8 is set to OFF. Set S202 on the SV-88A Board to ON.

NOTE :After check and adjustment, reset S201 and S202 on the SV-88A Board and remove the shorting clip from the SY-102A Board.

- (3) Turn the power ON. The Threading Ring turns automatically, unit is put into the Threading completion mode.
- (4) Press the button as request.

2. How to make a cassette tape without a lid

A cassette tape without a lid is used for Section 6-2-1, T Drawer Arm Position Adjustment. Make a cassette tape without a lid as follows:

- (1) Remove the * marked seven screws on the back of the cassette as shown in the figure, and remove the upper half of the cassette. (fig. 1)
- (2) Remove the molded portions of the cassette lid in the upper half with a flatblade screwdriver. (fig. 2)
- (3) Remove the cassette lid from the upper half.
- (4) Install the upper half on the lower half. At this time, properly position the two tape guides in the upper half with respect to the cassette tape. (fig. 3)
- (5) Tighten the seven screws of the cassette tape from the bottom.

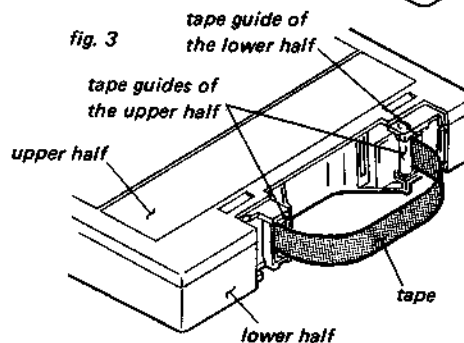
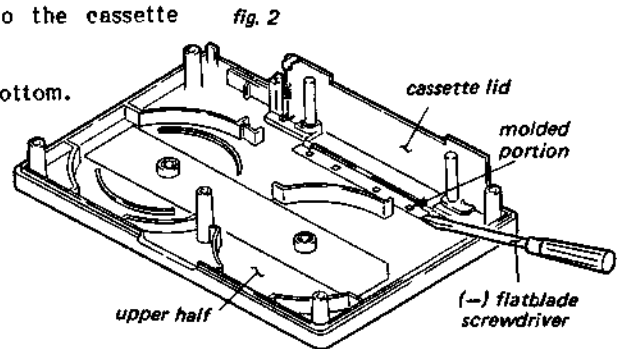
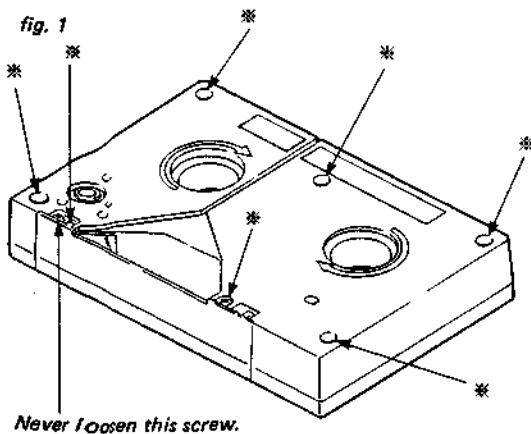

S/N 13731 AND HIGHER

ALIGNMENT INFORMATION

1. Operation of the unit without installing the cassette-up compartment and tape

- (1) Short between TP10 and E1 of the SY-102A Board with a shorting clip from the entrance of the Time Code Board.

(The clip will disable the Tape Beginning and Tape End Sensors.)

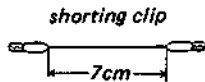

- (2) Set the Bit 7 of S101 on the SV-113 Board to ON. Set S301 on the SV-113 Board to ON.

NOTE: After check and adjustment, reset S101 and S301 on the SV-113 Board and remove the shorting clip from the SY-102A Board.

- (3) Turn the power ON. The Threading Ring turns automatically, unit is put into the Threading completion mode.
- (4) Press the button as request.

2. How to make a cassette tape without a lid

A cassette tape without a lid is used for Section 6-2-1, T Drawer Arm Position Adjustment. Make a cassette tape without a lid as follows:

- (1) Remove the * marked seven screws on the back of the cassette as shown in the figure, and remove the upper half of the cassette. (fig. 1)
- (2) Remove the molded portions of the cassette lid in the upper half with a flatblade screwdriver. (fig. 2)
- (3) Remove the cassette lid from the upper half.
- (4) Install the upper half on the lower half. At this time, properly position the two tape guides in the upper half with respect to the cassette tape. (fig. 3)
- (5) Tighten the seven screws of the cassette tape from the bottom.

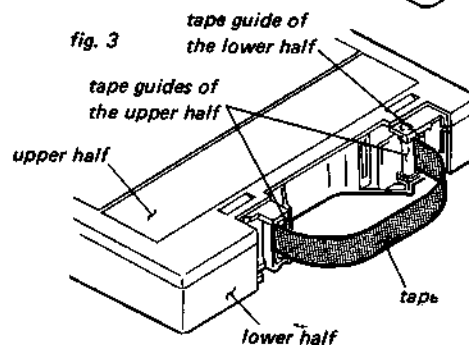
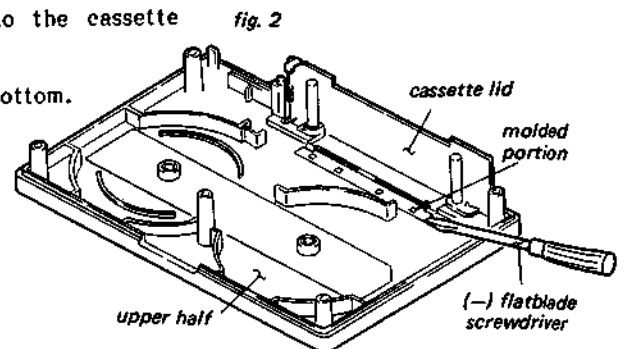
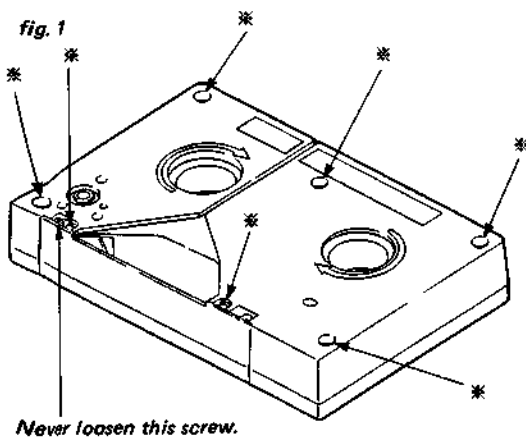

6-1. REEL TABLE SYSTEM ADJUSTMENT

6-1-1. Cassette Holder Position Adjustment

Tool: Reel table height check base jig
Thickness gauge
L-shaped hexagonal wrench
(across flat has 1.5 mm)

Mode: EJECT completion mode

Check procedure:

- (1) While lightly pushing the Reel Table Height Check Base Jig marked (A), (B) and (C) toward the chassis, check that the clearance between the base jig and the Cassette Holder meets the required specification.

Adjustment procedure:

- (1) Adjust the position of the Cassette Holder to meet the required specification.

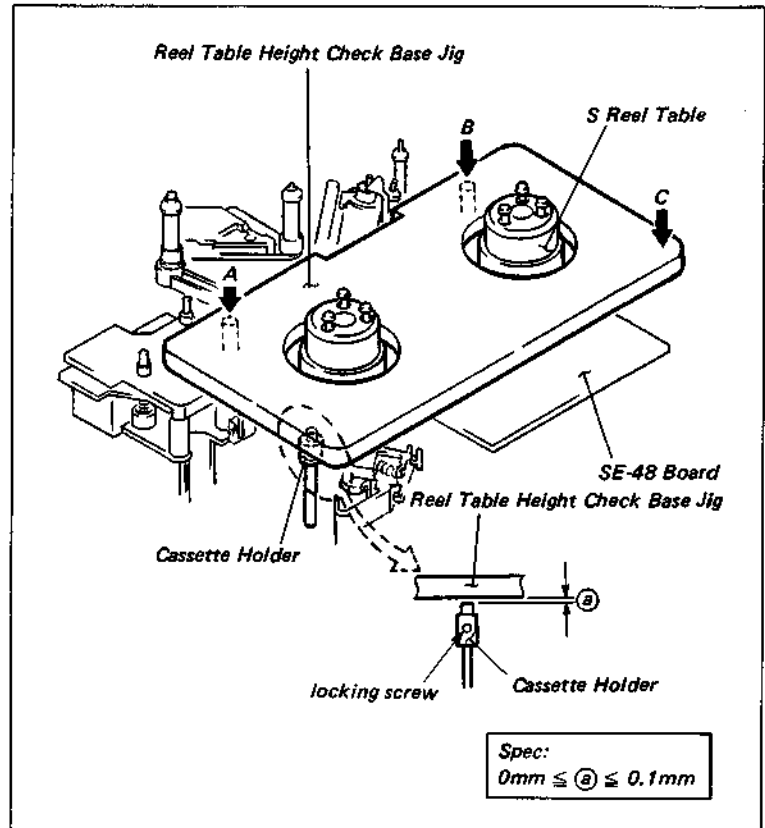

6-1-2. Reel Table Height Adjustment

. The height of the reel table is the reference for the tape threading system and the tape path system. This Adjustment should be performed very carefully.

Tools: Reel table height check base jig
Reel table height check jig
Hexagonal screwdriver
(across flat has 1.5 mm)

Mode: EJECT completion mode

Check procedure:

- (1) The probes of the Reel Table Height Check Jig marked "SO" and "TO" can slide over the reel table, leaving a clearance between the jig and the reel table. The probes marked "SX" and "TX" meet the flange and cannot slide over the reel table.
.Use the "SO" and "SX" probes for the Supply Reel Table.
.Use the "TO" and "TX" probes for the Take-up Reel Table.

Adjustment procedure:

. Supply Reel Table

- (1) Remove the front panel and insert a hexagonal screwdriver in the hole of the chassis as shown in the figure. Loosen the two set screws in the S Reel Table 1 to 2 turns. (The reel table is pushed up because a spring is under the reel table.)
- (2) While pressing down the reel table, adjust the height to meet the required specification. After adjustment, install the front panel to the unit.

. Take-up Reel Table

- (3) Remove the front panel and insert a hexagonal screwdriver in the hole of the chassis as shown in the figure. Loosen the two set screws in the T Reel Table 1 to 2 turns. (The reel table is pushed up because a spring is under the reel table.)
- (2) While pressing down the reel table, adjust the height to meet the required specification. After adjustment, install the front panel to the unit.

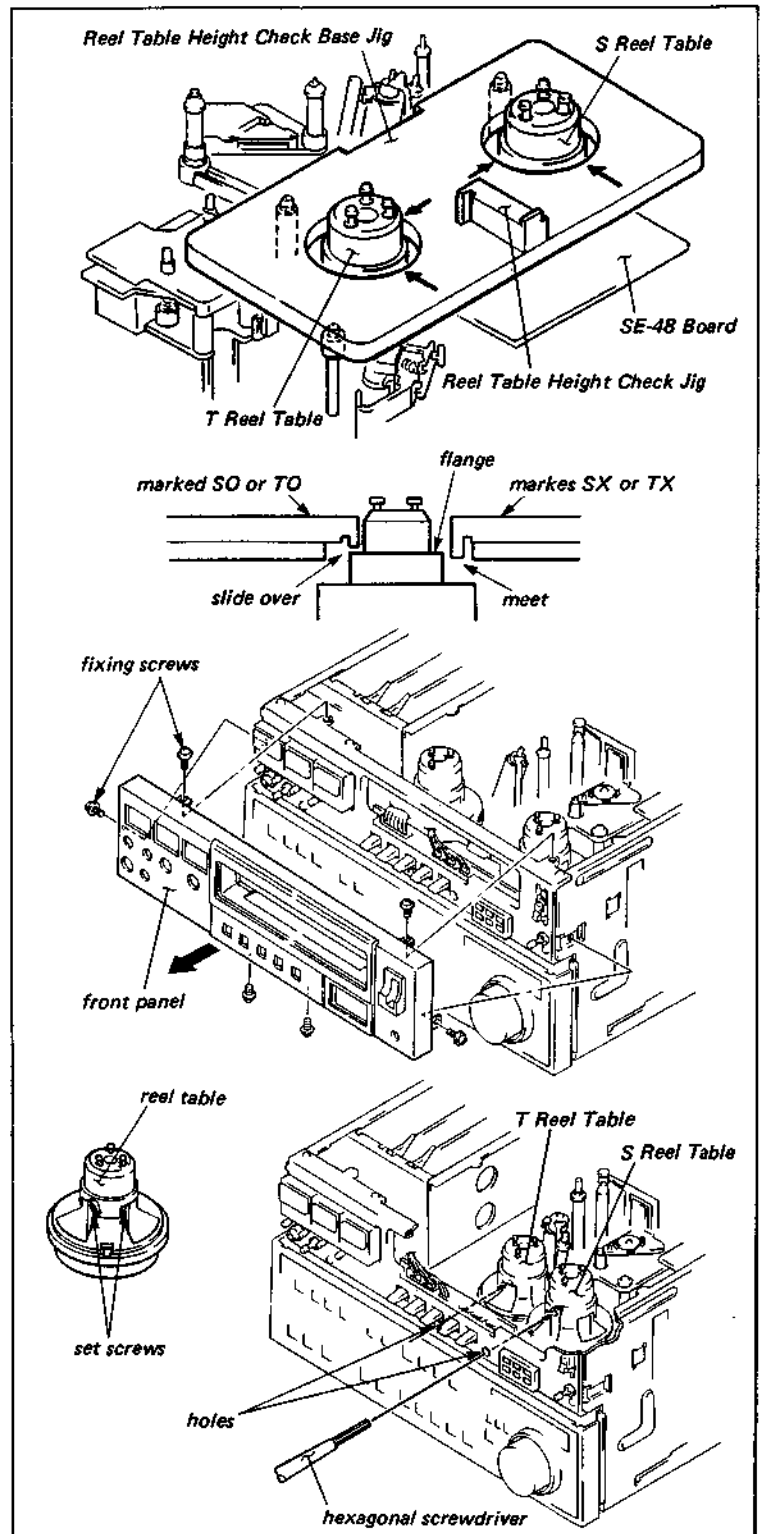

6-1-3. Reel Motor Shaft Slantness Adjustment

This adjustment is required only when the reel motor is replaced or removed.

Tool: Reel table height check base jig
Reel motor shaft slantness check jig

Mode: EJECT completion mode

Preparation:

- (1) Remove the reel table from the side of the Reel Motor requiring the adjustment.

Check procedure:

- (1) Place the Reel Table Height Check Base Jig as shown in the figure.
- (2) Set the Reel Motor Shaft Slantness Check Jig against the reel motor shaft from two directions as shown in the figure. Check that there is little clearance between the top or the bottom of the jig and the reel motor shaft.

Adjustment procedure:

- (1) Remove the three fixing screws of the motor. Insert a Reel Motor Spacer between the reel motor and the chassis and then adjust the slantness of the motor shaft to meet the required specification.

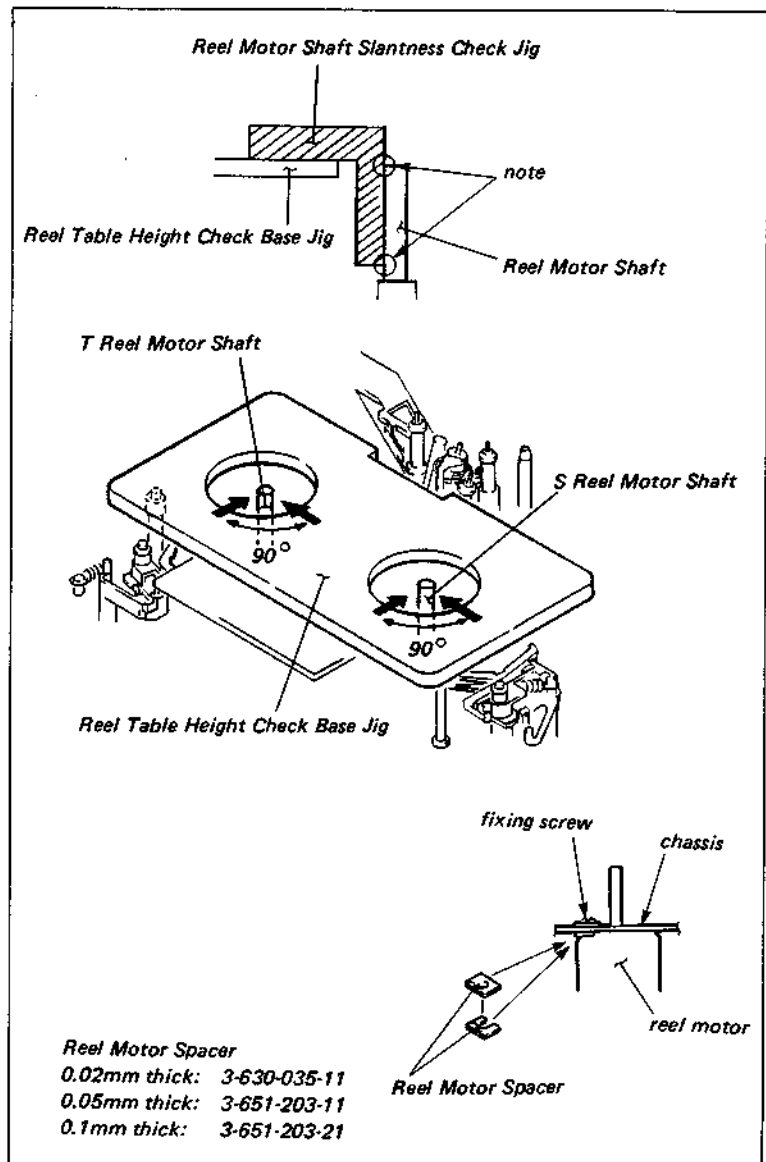

6-2. T DRAWER ARM BLOCK ADJUSTMENT

6-2-1. T Drawer Arm EJECT Position Adjustment

Tool: Cassette tape without a lid (Refer to the Alignment Information.)

Mode: EJECT completion mode

Check procedure:

- (1) Insert the cassette tape without a lid and put the unit into the threading mode. Press the EJECT button and put the unit into the EJECT completion mode.
- (2) Turn the power OFF.
- (3) Check that the clearance between the guide roller of the T Drawer Arm and a tape meets the required specification.

Adjustment procedure:

- (1) Perform check procedures (1) and (2).
- (2) Loosen the fixing screw of the Drive Link (B) Assembly 1/4 to 1/2 turn. Adjust the position of the Drive Link (B) Assembly to meet the required specification.
- (3) Tighten the fixing screw and check that the position of the Drive Link (B) Assembly meets the required specification.

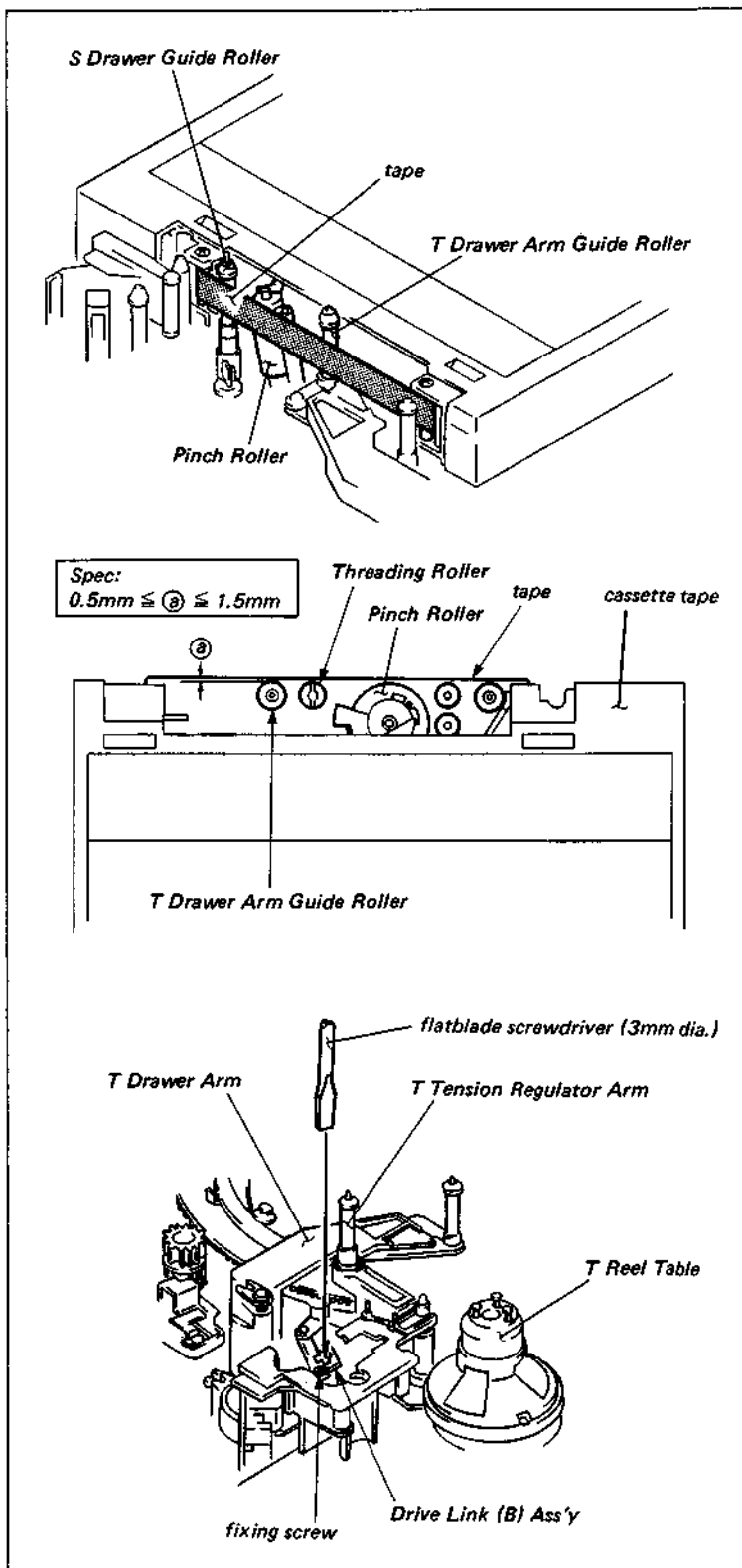

6-2-2. Unthread End Switch Position Adjustment

. Install the cassette-up compartment to the unit for this adjustment.

Tool: Thickness gauge

Mode: EJECT completion / POWER ON mode

Check procedure:

- (1) Turn the power ON and put the unit into the EJECT completion mode.
- (2) Turn the pulley of the Gear Box Block in the direction of arrow A until the T Brake Solenoid clicks. At this time, hold the pulley firmly by hand to stop its rotation.
- (3) Check that the clearance between the lower flange of the T Tension Regulator Arm and the T Drawer Arm meets the required specification.

Adjustment procedure:

- (1) Loosen the fixing screw of the Photo Interrupter Holder 1/4 to 1/2 turn.
- (2) Adjust the position of the Photo Interrupter Holder with a flatblade screwdriver (3 mm dia.) until clearance between the lower flange of the T Tension Regulator Arm and the T Drawer Arm meet the required specification.
- (3) After adjustment, perform the check procedure.
- (4) Turn the pulley of the Gear Box Block in the direction of arrow B by hand until the T Drawer Arm stops.

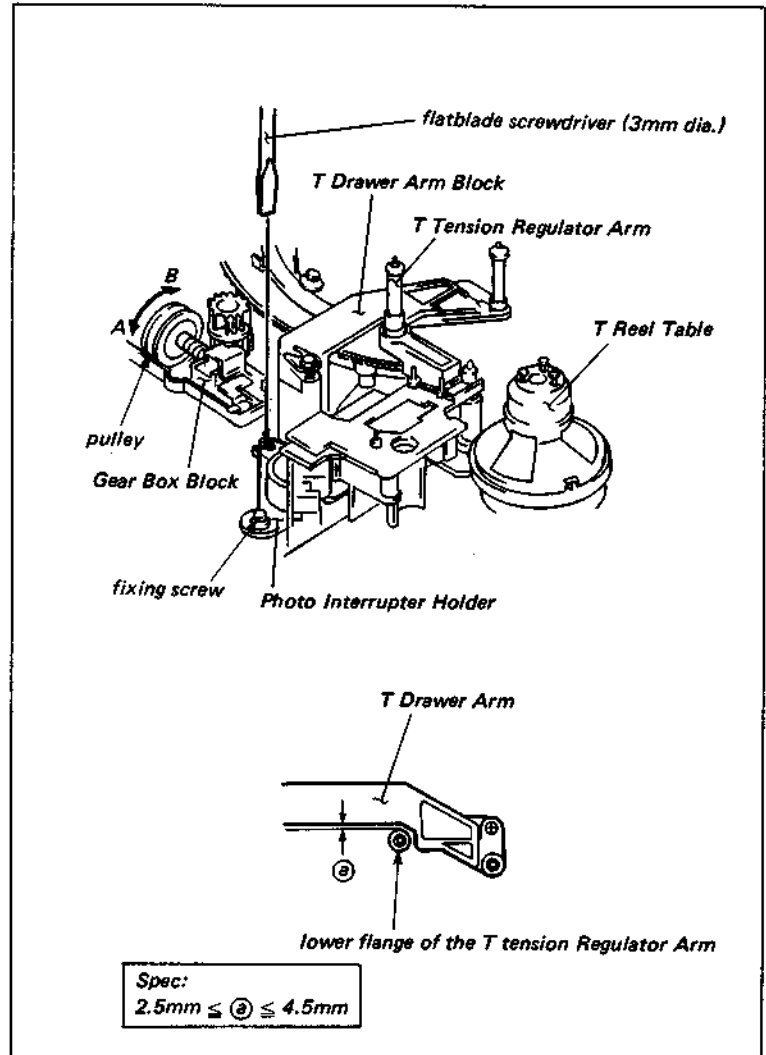

6-3. S TENSION DETECTOR ADJUSTMENT

6-3-1. S Tension Detector Roller Azimuth / Zenith Adjustment

Tool: Flatness plate

Mood: EJECT completion mode

Check procedure:

- (1) Hold the Flatness Plate against the TG-2 as shown in the figure and touch the Flatness Plate lightly against the S Tension Detector Roller. Check that the clearance between the detector roller and the Flatness Plate meets the required specification.
- (2) As viewed from the direction of arrow A, check that the S Tension detector roller is parallel to TG-2.

Adjustment procedure:

- (1) Loosen the fixing screw 1 to 2 turns.
- (2) Adjust the azimuth and the zenith adjustment screws of the S Tension Detector Roller to meet the required specifications.
- (3) Tighten the fixing screw and perform the check procedure.

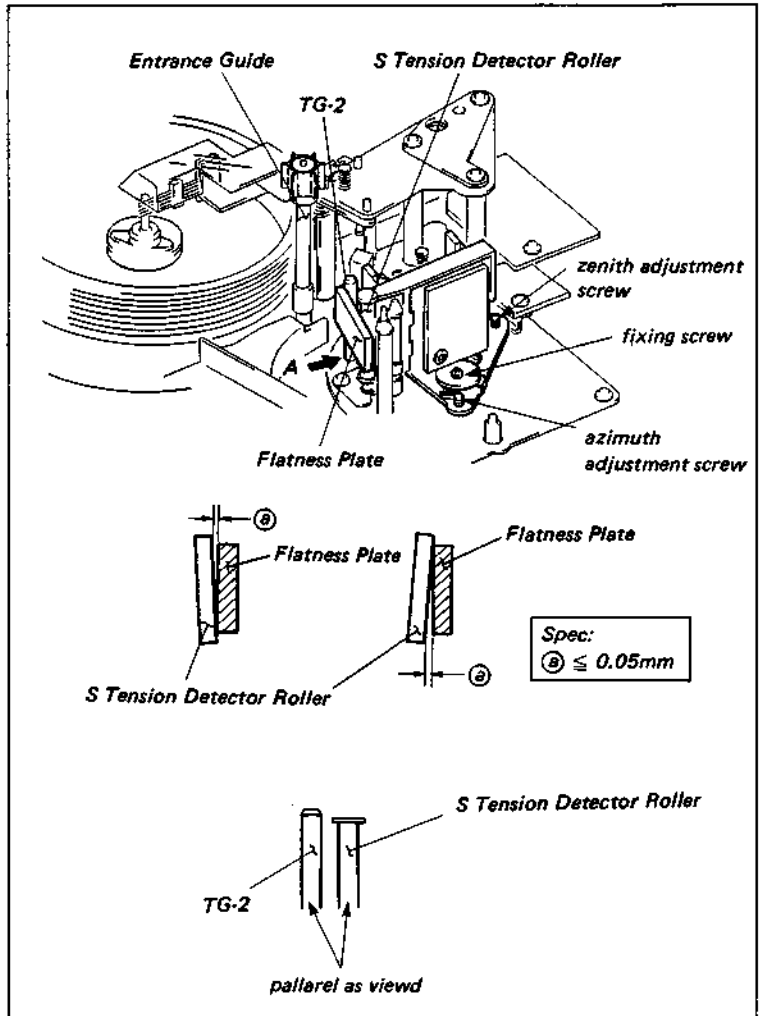

S/N UP TO 13730

6-3-2. S Tension Detector Operating Point Adjustment

Tool: Oscilloscope

Eccentric screwdriver (4φ)

Tension scale (100g full scale)

Extension board (EX-128)

Mode: EJECT completion mode without a cassette tape.

STAND BY OFF mode without a cassette tape.

Preparation:

- (1) Short between TP10 and E1 on the SY-102A Board with a shorting clip from the entrance of the Time Code Board. (The clip will disable the Tape Beginning and Tape End Sensors.)
- (2) Extend the SV-88A Board with an extension board.
- (3) Set the Bit 7 of S201 to ON and check that the Bit 8 is set to OFF. Set S202 to ON.
- (4) Connect the oscilloscope to TP602 on the SV-88A Board.

Check procedure:

- (1) Put the unit into the EJECT completion mode without a cassette tape.
- (2) Check that the voltage level at TP602 is $0 \pm 0.5V$. (spec. (1))
- (3) Put the unit the STAND BY OFF mode without a cassette tape.
- (4) Open the RP-30A Board. Tie a string to the S Tension Detector Leaf Spring as shown in the figure.
- (5) Hook a tension scale on the end of the string and pull it in the direction of the arrow.
- (6) When the voltage level at TP602 is 4 V, check that the tension scale reads $80.5 \pm 4 V$. (spec.(2))
- (7) If meets the required specification, reset S201 and S202 on the SV-88A Board and remove the shorting clip from the SY-102A Board.

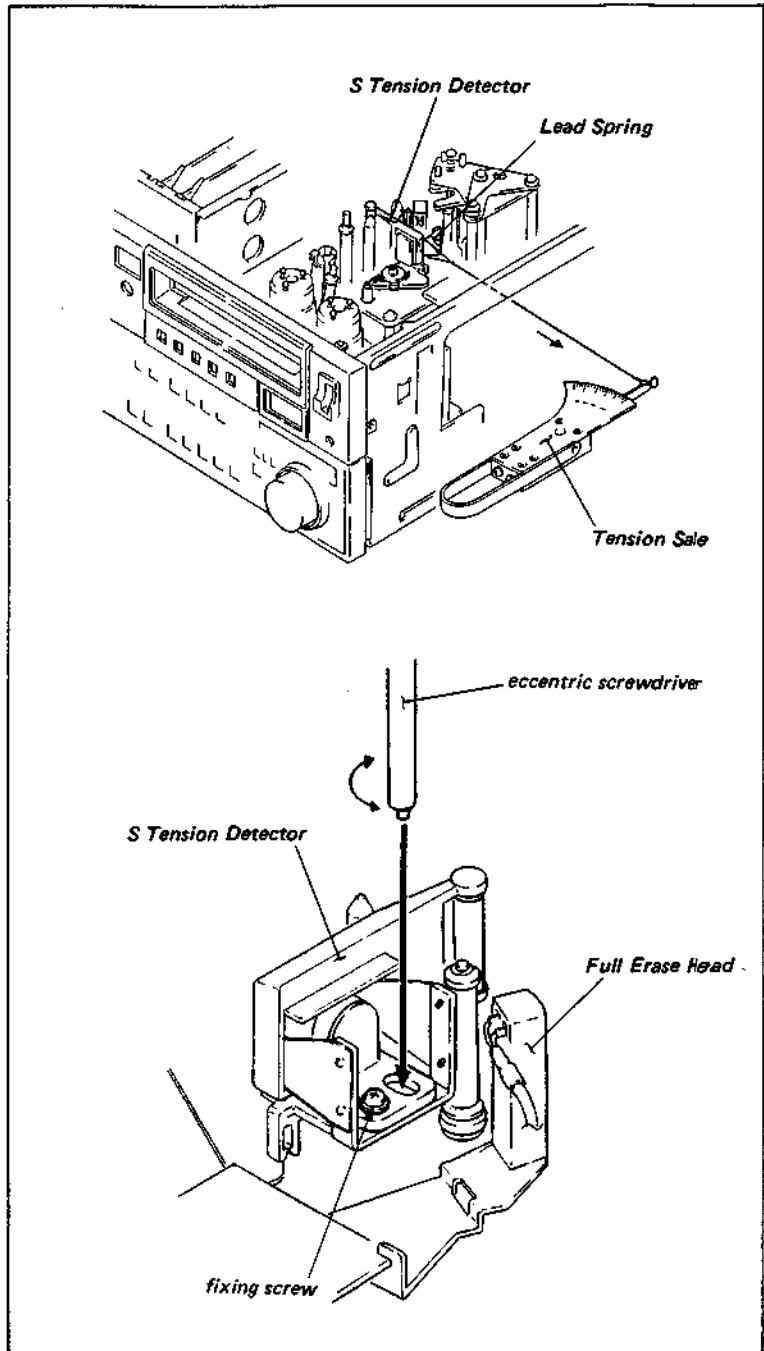

S/N 13731 AND HIGHER

6-3-2. S Tension Detector Operating Point Adjustment

Tool: Oscilloscope

Eccentric screwdriver (4#)

Tension scale (100g full scale)

Extension board (EX-128)

Mode: EJECT completion mode without a cassette tape.

STAND BY OFF mode without a cassette tape.

Preparation:

- (1) Short between TP10 and E1 on the SY-102A Board with a shorting clip from the entrance of the Time Code Board. (The clip will disable the Tape Beginning and Tape End Sensors.)
- (2) Extend the SV-113 Board with an extension board.
- (3) Set the Bit 7 of S101 to ON. Set S301 to ON.
- (4) Connect the oscilloscope to TP503 on the SV-113 Board.

Check procedure:

- (1) Put the unit into the EJECT completion mode without a cassette tape.
- (2) Check that the voltage level at TP503 is $0 \pm 0.5V$. (spec.(1))
- (3) Put the unit into the STAND BY OFF mode without a cassette tape.
- (4) Open the RP-30A Board. Tie a string to the S Tension Detector Leaf Spring as shown in the figure.
- (5) Hook a tension scale on the end of the string and pull it in the direction of the arrow.
- (6) When the voltage level at TP503 is 4 V, check that the tension scale reads 80.5 ± 4 V. (spec.(2))
- (7) If it meets the required specification, reset S101 and S301 on the SV-113 Board and remove the shorting clip from the SY-102A Board.

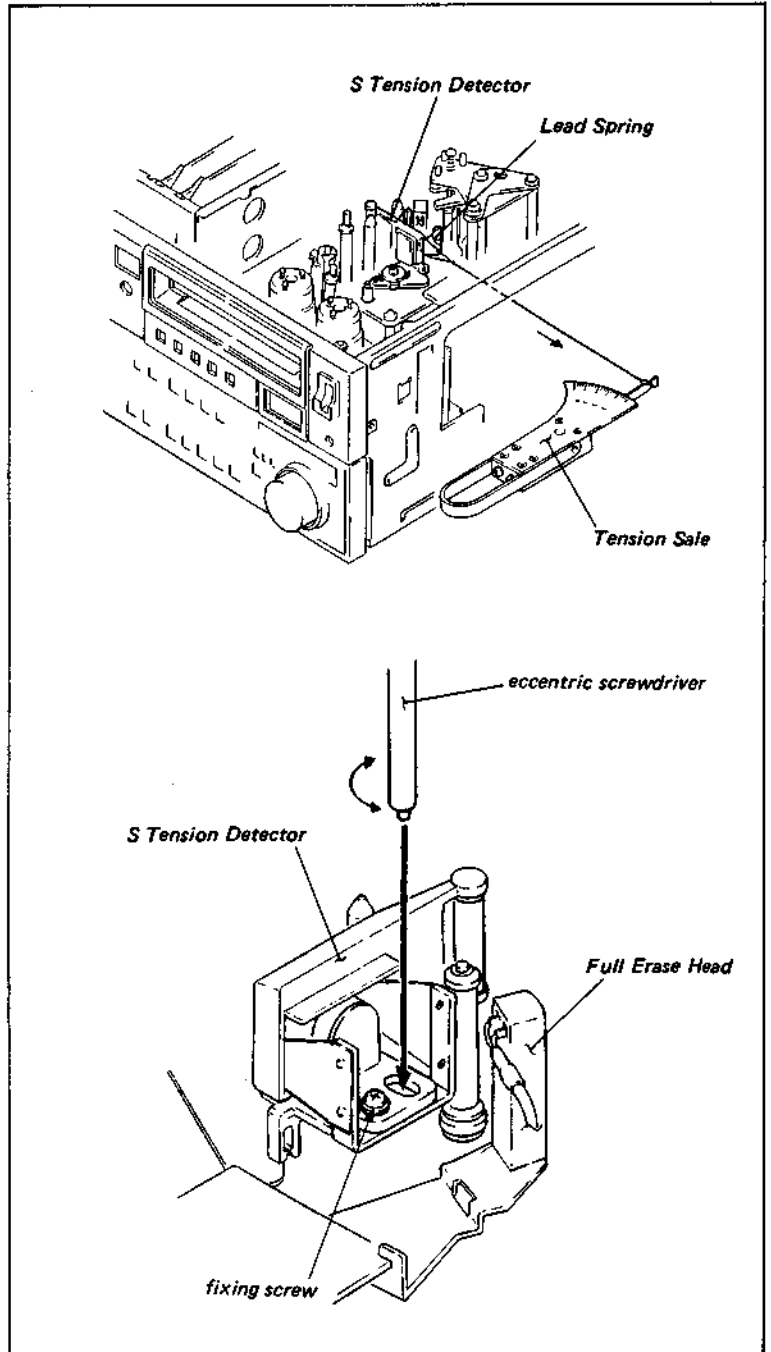



S/N UP TO 13730**Adjustment procedure:**

- . For spec. (1)
 - (1) Loosen the fixing screw 1/4 to 1/2 turn.
 - (2) Insert an eccentric screwdriver and adjust the position of the S Tension Detector to meet the required specification.
- . For spec. (2)
 - (3) Adjust the RV601 on the SV-88A Board to meet the required specification.
 - (4) After adjustment, perform the check procedure.
 - (5) Reset S201 and S202 on the SV-88A Board and remove the shorting clip from the SY-102A Board.

S/N 13731 AND HIGHER**Adjustment procedure:**

- . For spec. (1)
 - (1) Loosen the fixing screw 1/4 to 1/2 turn.
 - (2) Insert an eccentric screwdriver and adjust the position of the S Tension Detector to meet the required specification.
- . For spec. (2)
 - (3) Adjust the RV502 on the SV-113 Board to meet the required specification.
 - (4) After adjustment, perform the check procedure.
 - (5) Reset S101 and S301 on the SV-113 Board and remove the shorting clip from the SY-102A Board.

6-4. T TENSION DETECTOR ADJUSTMENT**6-4-1. T Tension Detector Guide Height Adjustment**

Tool: L-shaped hexagonal wrench
(across flat has 1.5 mm)

Mode: PLAY / F FWD mode with a cassette tape

Check procedure:

- (1) Insert a cassette tape and put the unit into the PLAY mode.
- (2) Check that the tape runs in the middle of the tape guide in the cassette.
- (3) Check that the tape runs in the middle of the T Tension Detector Guide.
- (4) Put the unit into the F FWD mode.
- (5) Check as described in steps (2) and (3).

Adjustment procedure:

- (1) Loosen the set screw in the lower flange of the T Tension Detector Roller.
- (2) Adjust the height of the T Tension Detector Roller to meet the required specification.

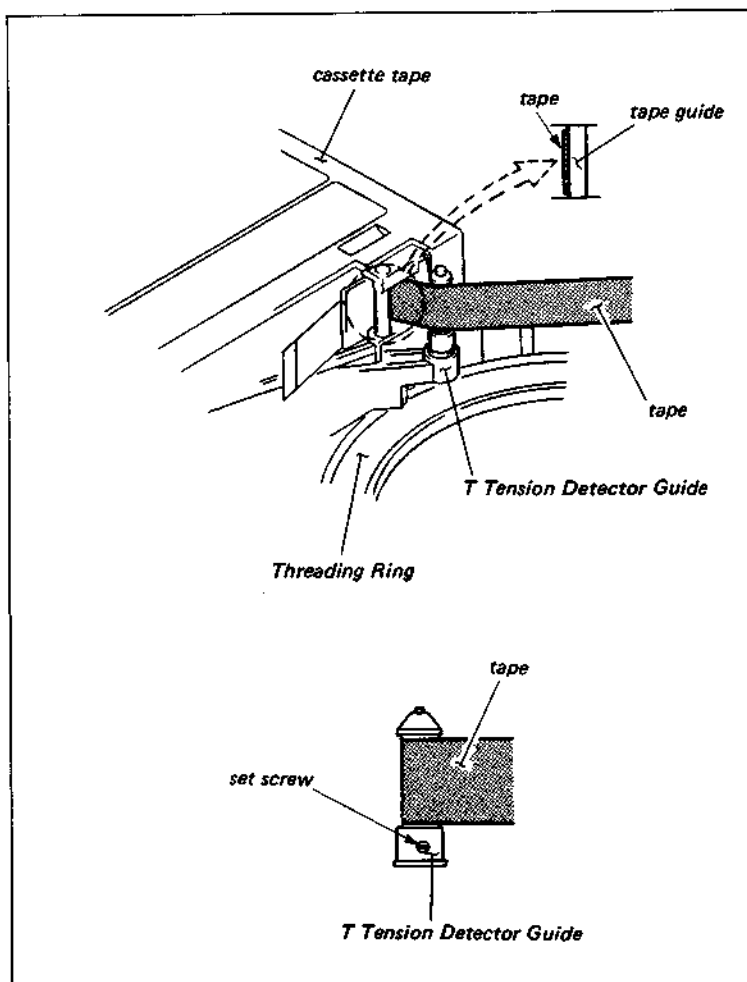

6-4-2. T Tension Detector Guide Operating Position Adjustment

Mode: EJECT completion mode

Check procedure:

- (1) Check that the clearance between the lower flange of the T Tension Detector Guide and the T Drawer Arm to meet the required specification.

Adjustment procedure:

- (1) Remove the TRC Detector Block after removing the fixing screw.
- (2) Loosen the fixing screw of the T Spring Base 1/4 to 1/2 turn.
- (3) While pushing the T Tension Detector Guide in the direction of the arrow, adjust the position of the guide with a flatblade screwdriver (3 mm dia.) to meet the required specification.
- (4) Put the notch of the TRC Detector Block in the groove of the Cassette Holder. While pushing the TRC Detector Block in the direction of the arrow, install it on the unit.
- (5) After adjustment, perform Section 6-4-3, T Tension Detector Operating Point Adjustment.

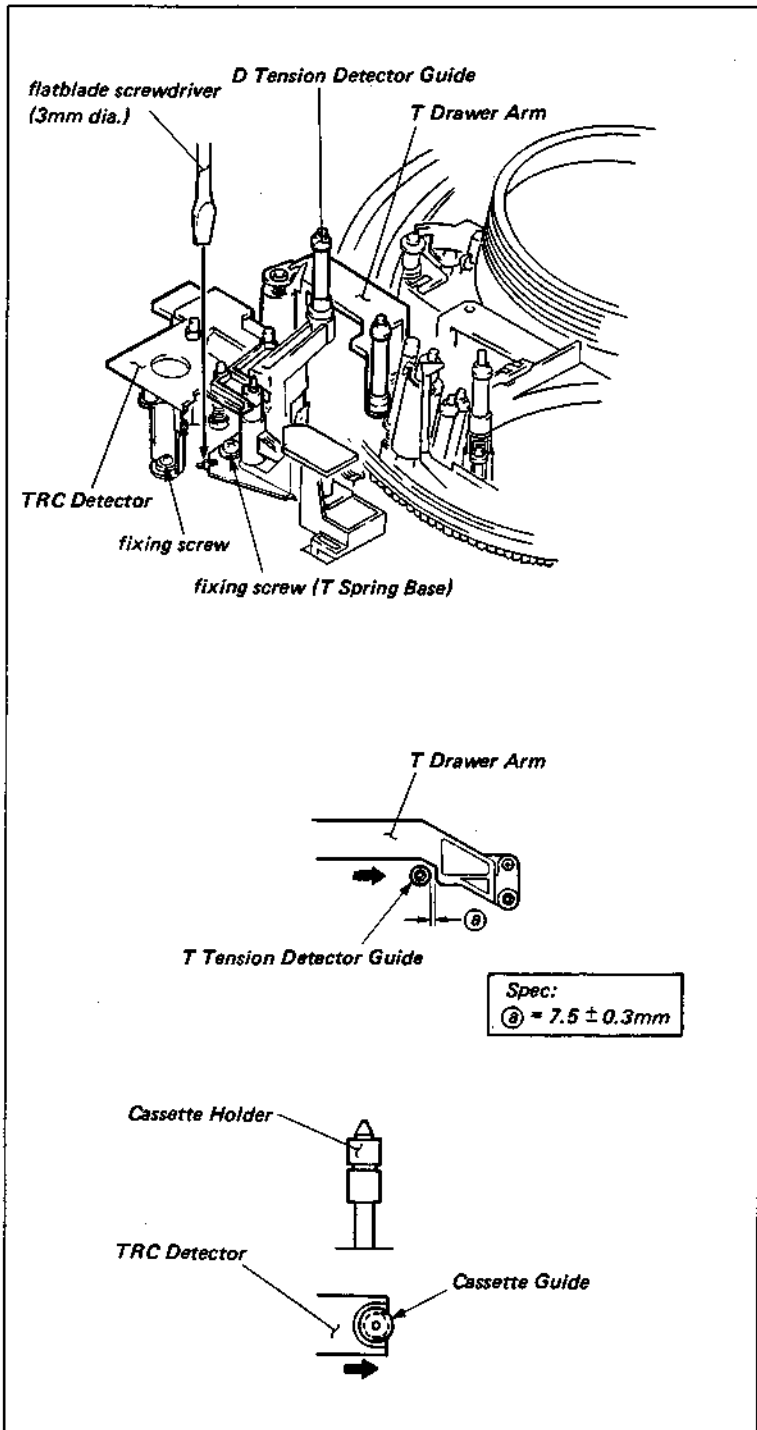



S/N UP TO 13730

6-4-3. T Tension Detector Operating Point Adjustment

. It is required that Section 6-4-2, T Tension Detector Guide Operating Position Adjustment is correct before initiating this adjustment.

Tool: Oscilloscope

Special jig tape

This tape should be prepared as follows:

. Cut a piece of video tape, 4 cm long. Form a loop as shown in the figure and secure the end of the loop with a small piece of adhesive tape. Put another piece of adhesive tape on the free end of the jig tape and make a hole through it. Lace a piece of string through the hole and tie a small loop.

Eccentric screwdriver (4 ϕ)

Tension scale (100g full scale)

Extension board (EX-128)

Mode: EJECT completion mode without a cassette tape.

STAND BY OFF mode without a cassette tape.

Preparation:

- (1) Short between TP10 and E1 on the SY-102A Board with a shorting clip from the entrance of the Time Code Board. (The clip will disable the Tape Beginning and Tape End Sensors.)
- (2) Extend the SV-88A Board with the extension board.
- (3) Set the Bit 7 of S201 to ON and check that the Bit 8 is set to OFF. Set S202 to ON.
- (4) Connect the oscilloscope to TP604 on the SV-88A Board.

Check procedure:

- (1) Put the unit into the EJECT completion mode without a cassette tape.
- (2) Check that the voltage level at TP604 is $0 \pm 0.5V$. (spec. (1))
- (3) Put the unit into the STAND BY OFF mode without a cassette tape.

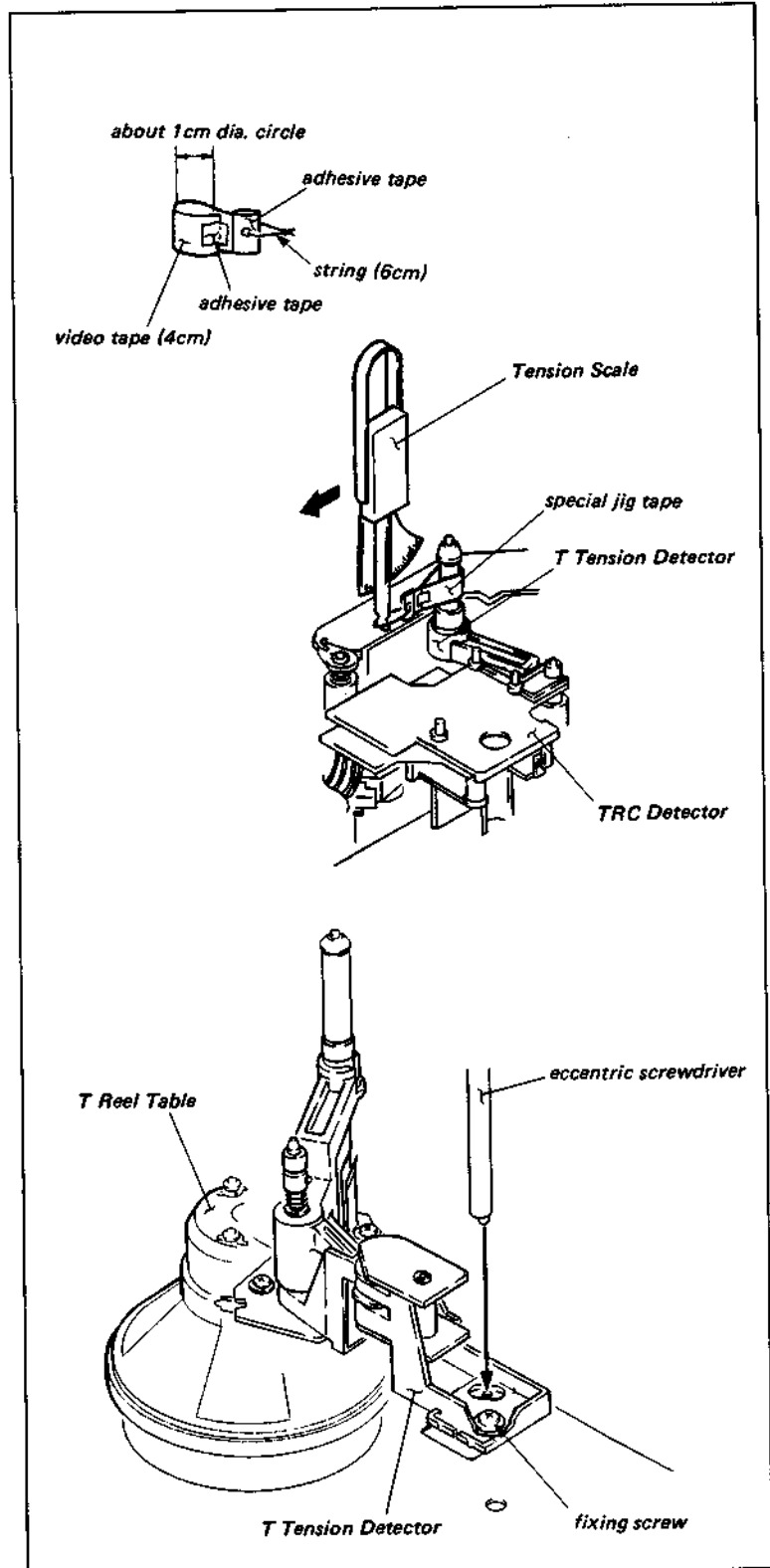

S/N 13731 AND HIGHER

6-4-3. T Tension Detector Operating Point Adjustment

. It is required that Section 6-4-2, T Tension Detector Guide Operating Position Adjustment is correct before initiating this adjustment.

Tool: Oscilloscope

Special jig tape

This tape should be prepared as follows:

. Cut a piece of video tape, 4 cm long. Form a loop as shown in the figure and secure the end of the loop with a small piece of adhesive tape. Put another piece of adhesive tape on the free end of the jig tape and make a hole through it. Lace a piece of string through the hole and tie a small loop.

Eccentric screwdriver (4 ϕ)

Tension scale (100g full scale)

Extension board (EX-128)

Mode: EJECT completion mode without a cassette tape.

STAND BY OFF mode without a cassette tape.

Preparation:

- (1) Short between TP10 and E1 on the SY-102A Board with a shorting clip from the entrance of the Time Code Board. (The clip will disable the Tape Beginning and Tape End Sensors.)
- (2) Extend the SV-113 Board with the extension board.
- (3) Set the Bit 7 of S101 to ON. Set S301 to ON.
- (4) Connect the oscilloscope to TP508 on the SV-113 Board.

Check procedure:

- (1) Put the unit into the EJECT completion mode without a cassette tape.
- (2) Check that the voltage level at TP508 is $0 \pm 0.5V$. (spec.(I))
- (3) Put the unit into the STAND BY OFF mode without a cassette tape.

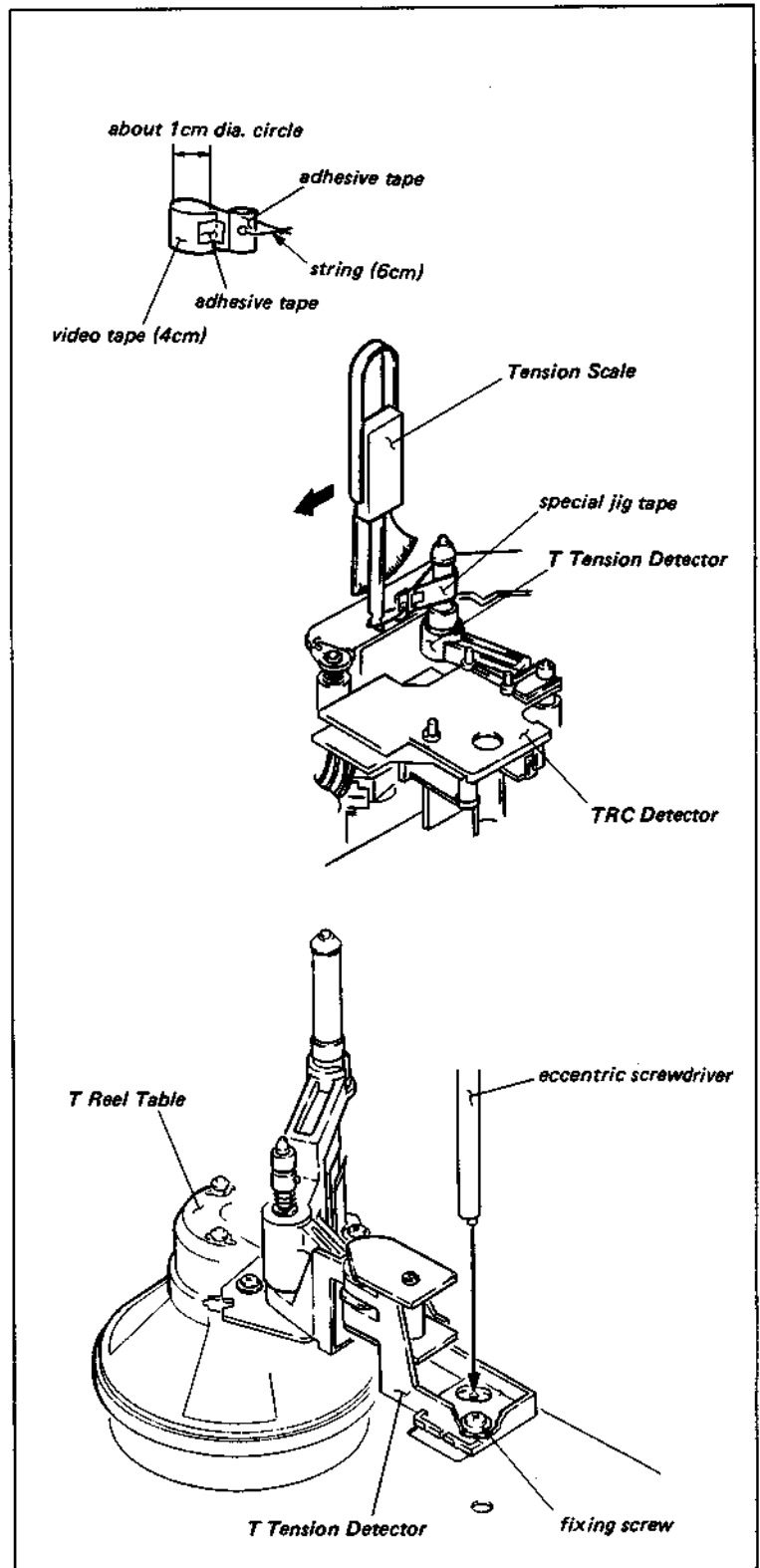

S/N UP TO 13730

- (4) Place the special jig tape on the T Tension Regulator.
- (5) Hook the tension scale to the string from the special jig tape and pull it in the direction of the arrow.
- (6) When the voltage level at TP604 is 4 V, check that the tension scale reads 51 56 g. (spec. (2))
- (7) If meets the required specificaiton, reset S201 and S202 on the SV-88A Board and remove the shorting clip from the SY-102A Board.

Adjustment procedure:

. For spec. (1)

- (1) Loosen the fixing screw of the T Tension Detector Block 1/4 to 1/2 turn.
- (2) Adjust the position of the T Tension Detector with an eccentric screwdriver to meet the required specification.

. For spec. (2)

- (3) Adjust the RV602 on the SV-88A Board to meet the required specification.
- (4) After adjustment, perform the check procedure.
- (5) Reset S201 and S202 on the SV-88A Board and remove the shorting clip from the SY-102A Board.

S/N 13731 AND HIGHER

- (4) Place the special jig tape on the T Tension Regulator.
- (5) Hook the tension scale to the string from the special jig tape and pull it in the direction of the arrow.
- (6) When the voltage level at TP508 is 4 V, check that the tension scale reads 51 56 g. (spec. (2))
- (7) If meets the required specificaiton, reset S101 and S301 on the SV-113 Board and remove the shorting clip from the SY-102A Board.

Adjustment procedure:

. For spec. (1)

- (1) Loosen the fixing screw of the T Tension Detector Block 1/4 to 1/2 turn.
- (2) Adjust the position of the T Tension Detector with an eccentric screwdriver to meet the required specification.

. For spec. (2)

- (3) Adjust the RV503 on the SV-113 Board to meet the required specification.
- (4) After adjustment, perform the check procedure.
- (5) Reset S101 and S301 on the SV-113 Board and remove the shorting clip from the SY-102A Board.

6-5. THREADING SYSTEM ADJUSTMENT

6-5-1. Threading Ring Rotation Adjustment

- . This adjustment is required only when the Threading Ring is replaced or removed.
- . If the Threading Ring is adjusted to a narrower clearance, the ring rotation becomes sluggish. If it is adjusted to a wider clearance, tape run during Threading, PLAY, F FWD, REW and REV modes will be unstable.

Mode: Check mode: EJECT completion/
Threading/Unthreading
Adjustment mode: EJECT completion mode

Check procedure:

- (1) Put the unit into the EJECT completion mode. Check that horizontal play meets the required specification when the Threading Ring is pushed in the direction of the arrow.
- (2) Check that the rotation of the Threading Ring during the threading and unthreading modes is smooth.

Adjustment procedure:

- (1) Put the unit into the EJECT completion mode.
- (2) Adjust the position of the Ring Roller (C) to meet the required specification.

Reference:

- . Insert a 0.3 mm thick piece of paper between the Threading Ring and the Ring Roller (C) as shown in the figure.
- . Three pages of this service manual are 0.3 mm thick.

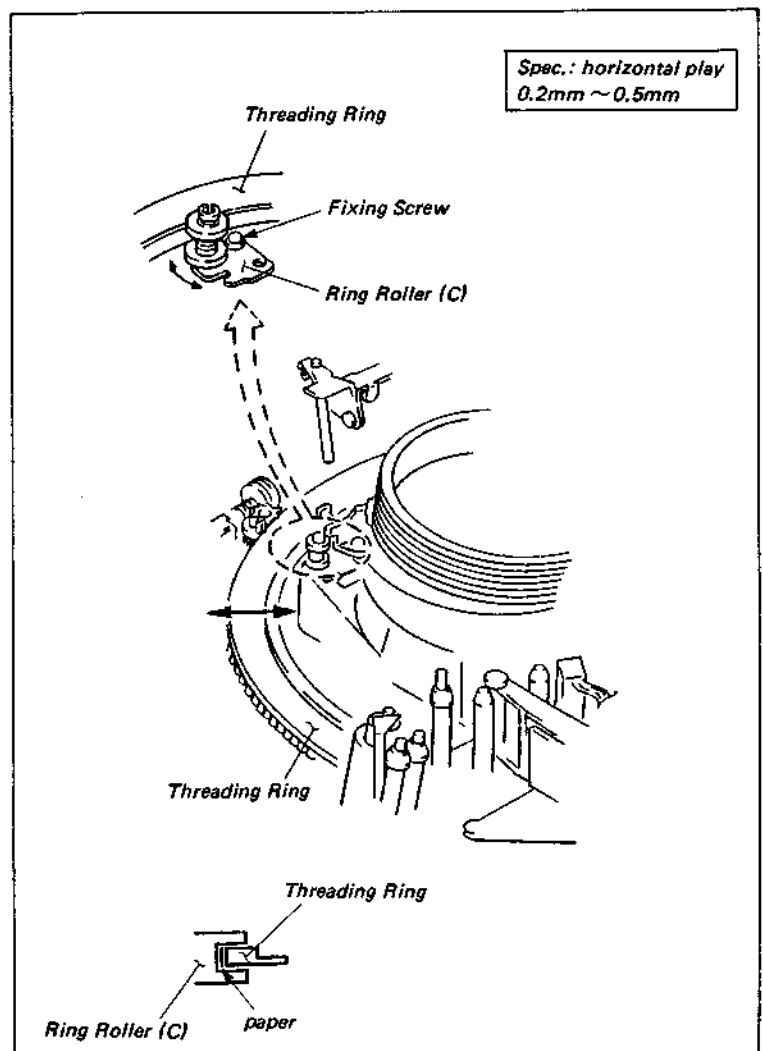

S/N UP TO 13730

6-5-2. Gear Box Installing Position Adjustment

It is required that Section 6-5-1, Threading Ring Rotation Adjustment is correct before initiating this adjustment.

Mode: Put the unit into the EJECT completion mode. Turn the pulley of the Gear Box 1/2 to 1 turn in the direction of arrow C.

Check procedure:

- (1) Put the unit into the EJECT completion mode and then turn the pulley of the Gear Box 1/2 to 1 turn in the direction of arrow C.
- (2) Mark two lines on the top surface of the gear with a black felt tip pen. (Two lines are easy to see during the adjustment.)
- (3) Turn the pulley in the direction of arrow C or D until one of the lines is roughly parallel to the outer circumference of the Threading Ring.
- (4) Check that the relationship between the outer circumference of the Threading Ring and the Gear meets the required specification.

Adjustment procedure:

- (1) Remove the SV-88A Board and the DM-55 Board.
- (2) Turn the pulley in the direction of arrow C or D until one of the lines is roughly parallel to the outer circumference of the Threading Ring.
- (3) Move the Gear Box in the direction of arrow E to meet the required specification.
- (4) Check that Section 6-5-1, Threading Ring Rotation Adjustment meets the required specification.
- (5) Check that \odot meets the required specification at the longitudinal hole of the gear block as shown in the figure.

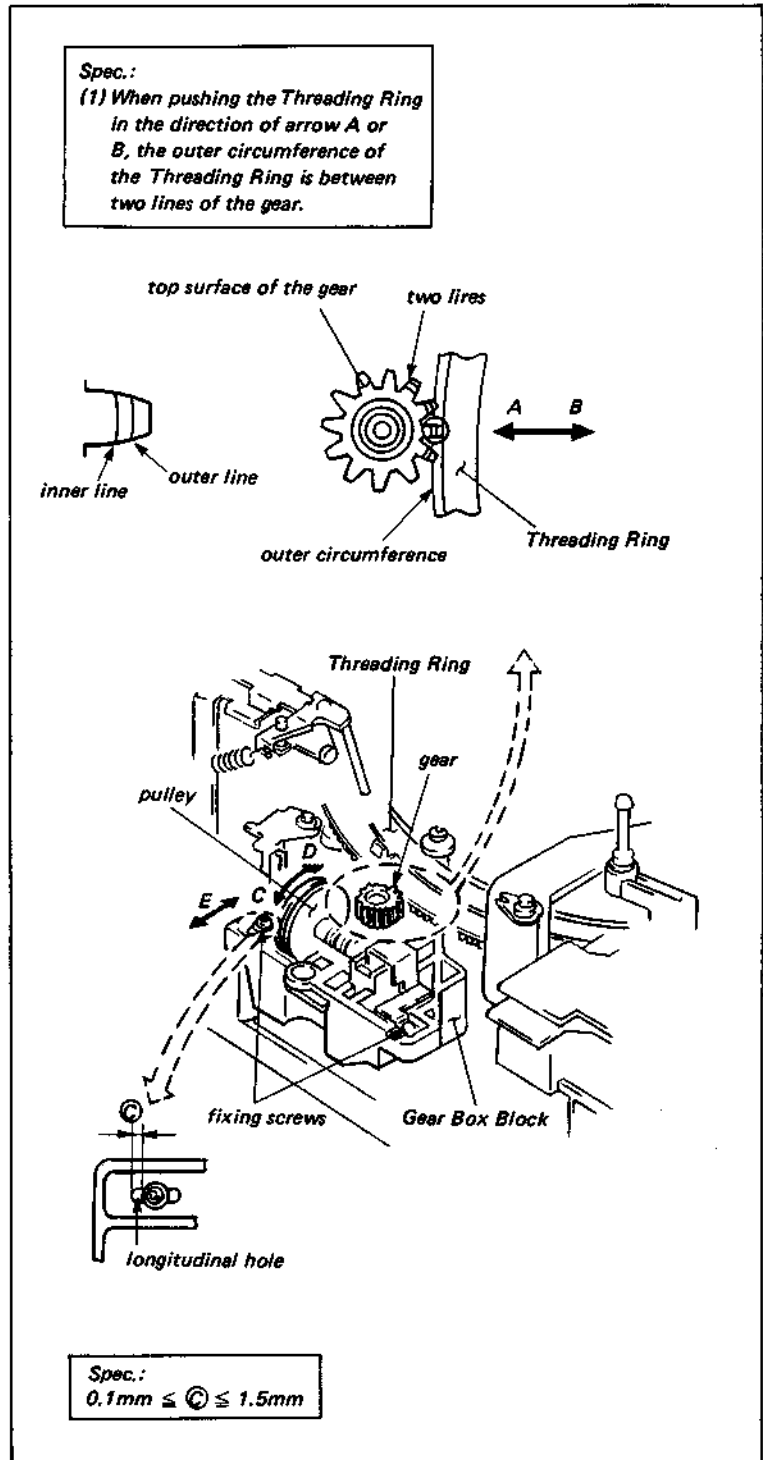

S/N 13731 AND HIGHER

6-5-2. Gear Box Installing Position Adjustment

It is required that Section 6-5-1, Threading Ring Rotation Adjustment is correct before initiating this adjustment.

Mode: Put the unit into the EJECT completion mode. Turn the pulley of the Gear Box 1/2 to 1 turn in the direction of arrow C.

Check procedure:

- (1) Put the unit into the EJECT completion mode and then turn the pulley of the Gear Box 1/2 to 1 turn in the direction of arrow C.
- (2) Mark two lines on the top surface of the gear with a black felt tip pen. (Two lines are easy to see during the adjustment.)
- (3) Turn the pulley in the direction of arrow C or D until one of the lines is roughly parallel to the outer circumference of the Threading Ring.
- (4) Check that the relationship between the outer circumference of the Threading Ring and the Gear meets the required specification.

Adjustment procedure:

- (1) Remove the SV-113 Board and the DM-55 Board.
- (2) Turn the pulley in the direction of arrow C or D until one of the lines is roughly parallel to the outer circumference of the Threading Ring.
- (3) Move the Gear Box in the direction of arrow E to meet the required specification.
- (4) Check that Section 6-5-1, Threading Ring Rotation Adjustment meets the required specification.
- (5) Check that \odot meets the required specification at the longitudinal hole of the gear block as shown in the figure.

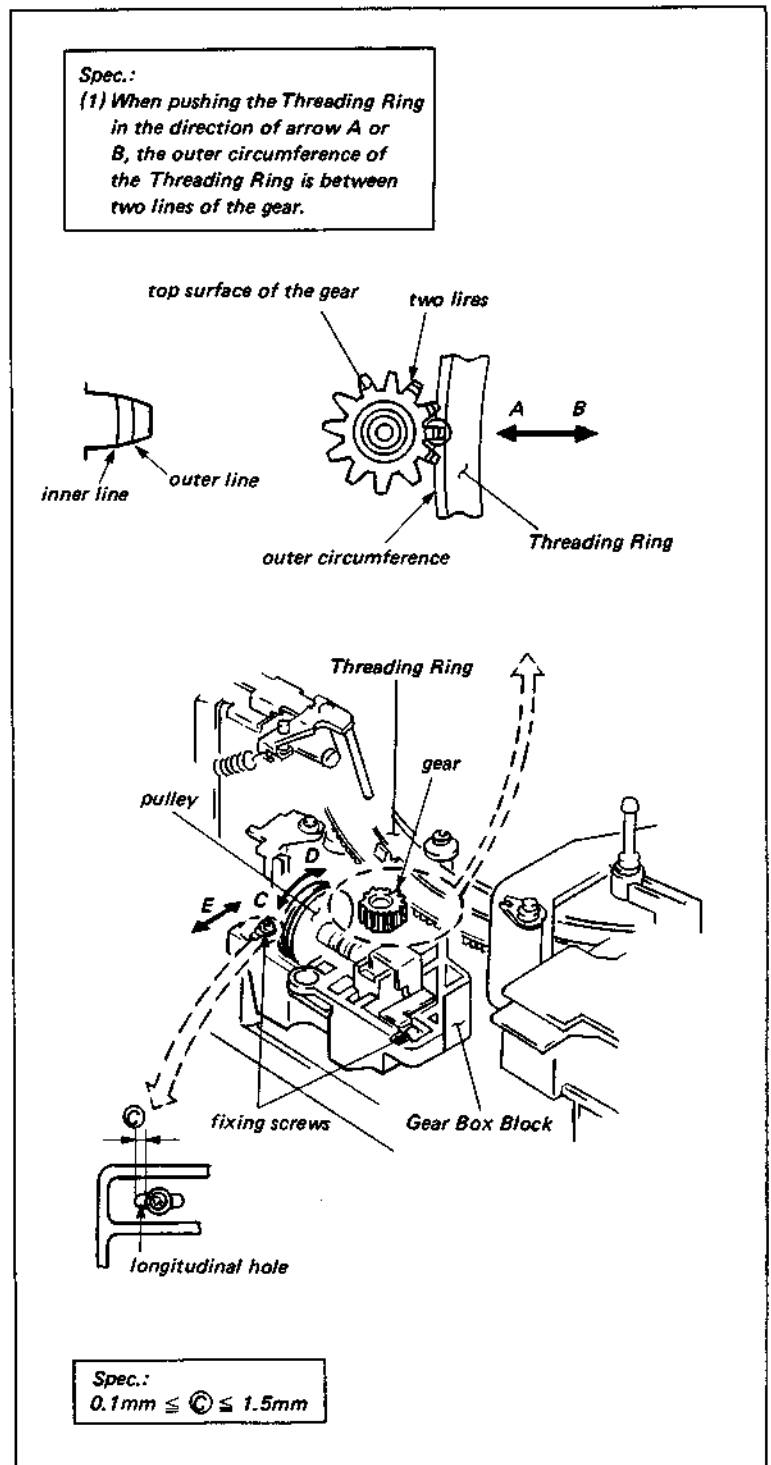

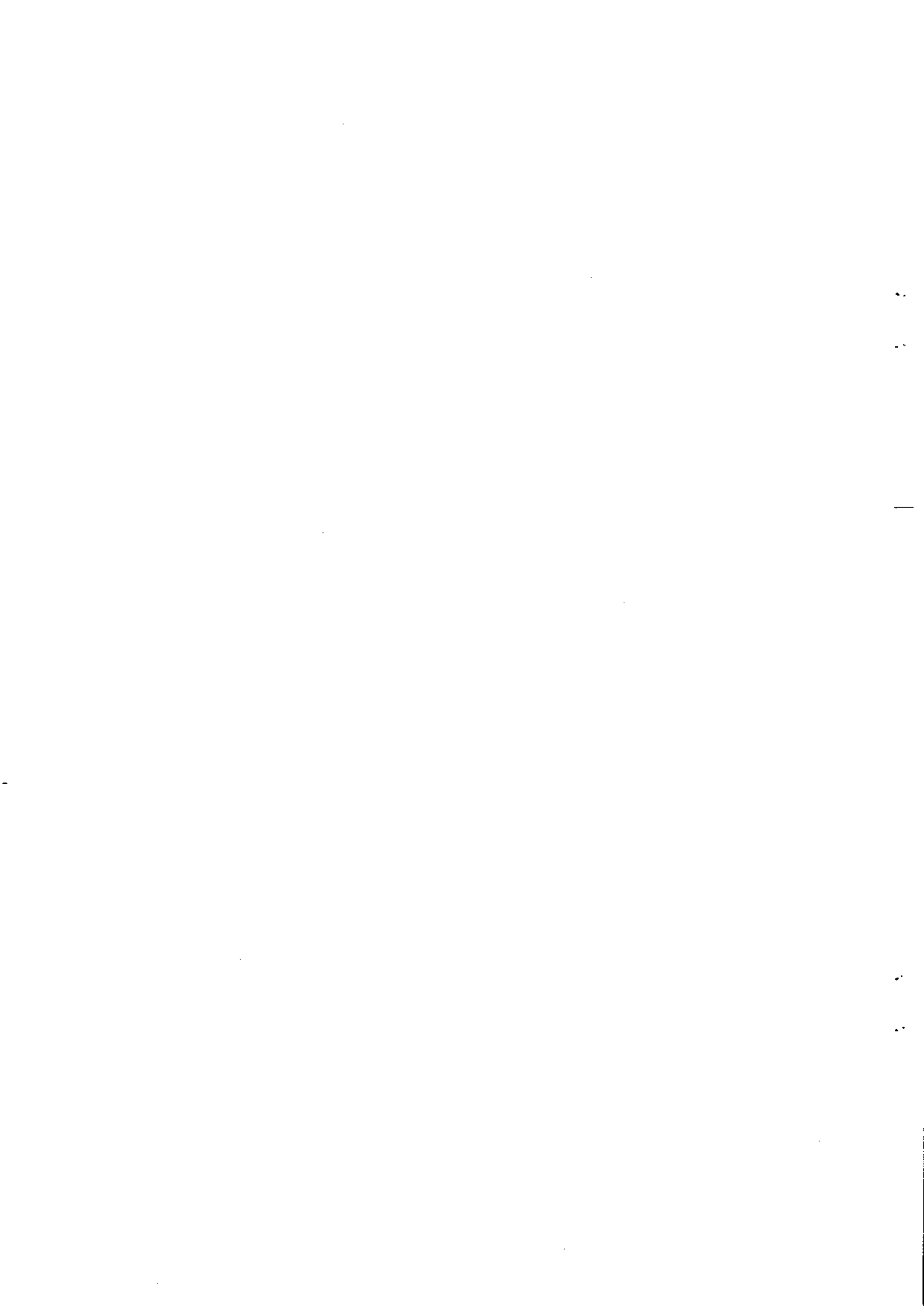

6-5-3. Pinch Roller Self Alignment Adjustment

- . If this adjustment is incorrect, the position and the slantness of the Pinch Roller will not be correct when the Pinch Roller is pressed against the Capstan Shaft. Incorrect adjustment will cause a tape to be damaged.
- . After adjustment, perform Section 6-6-2, Pinch Roller Preset Adjustment.

Mode: PLAY mode without a cassette tape

Check procedure:

- (1) Put the unit into the PLAY mode without a cassette tape.
- (2) Check that the relationship of Pinch Roller Arm (A) and Pinch Roller Arm (B) meets the required specification.

Adjustment procedure:

- (1) Open the MD-45 Board.
- (2) Put the unit into the PLAY mode without a cassette tape.
- (3) Loosen the fixing screw in the Sub-ring Stopper.
- (4) Turn the pulley of the Gear Box Block in the direction of the arrow to meet the required specification.
- (5) Push the Sub-ring Stopper gently in the direction of the arrow and tighten the fixing screw.
- (6) Put the unit into the EJECT completion mode and then perform the check procedure.
- (7) Install the MD-45 Board.

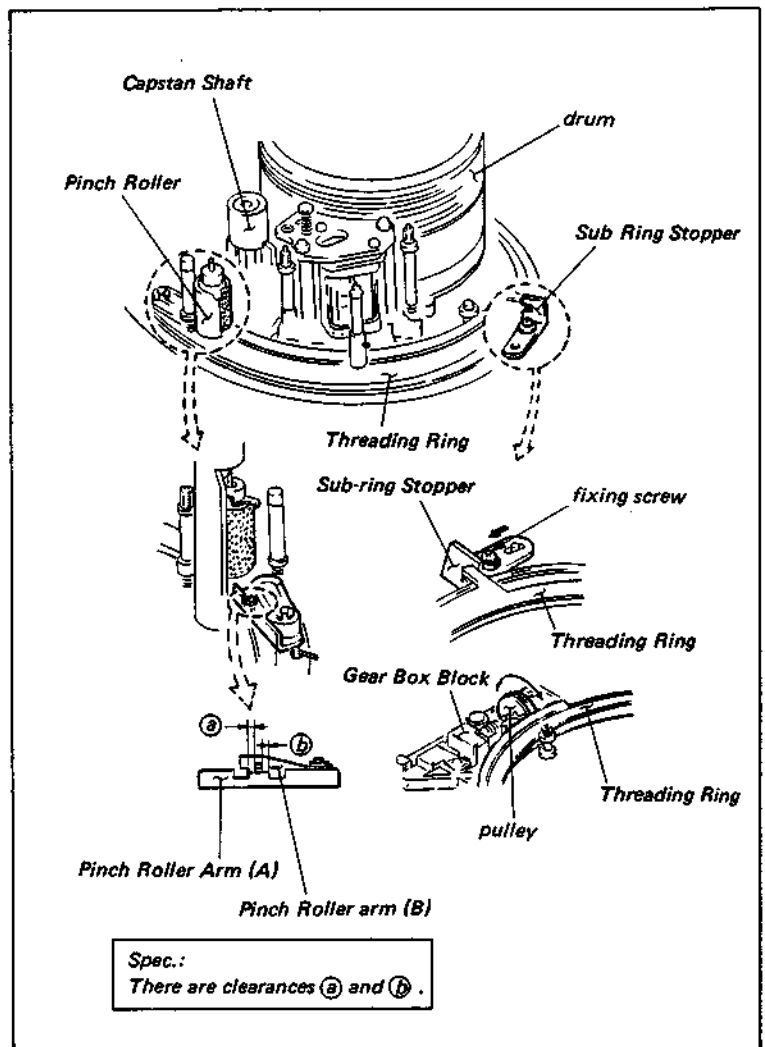

6-5-4. FR Detector Block Installing Position Adjustment

. It is required that Section 6-5-1, Threading Ring Rotation Adjustment is correct before initiating this adjustment.

Mode: Threading completion mode

Adjustment procedure:

- (1) Put the unit into the threading completion mode and turn the power OFF.
- (2) Open the MD-45 Board.
- (3) Remove the Pinch Press Lever Spring from the bracket of the FR Detector Block with tweezers.
- (4) Loosen the fixing screw of the FR Detector Block 1/4 to 1/2 turn.
- (5) Press the FR Detector Block against the Threading Ring and then pull it away about 1 mm (no more than 1.5 mm). (Spec. (1))
- (6) Move the FR Detector Block in the direction of the arrow to meet the required specification (2).
- (7) Check that the position of the FR Detector meets the required specification (1).
- (8) Hook the Pinch Press Lever Spring back on the bracket of the FR Detector Block with tweezers.
- (9) Install the MD-45 Board.

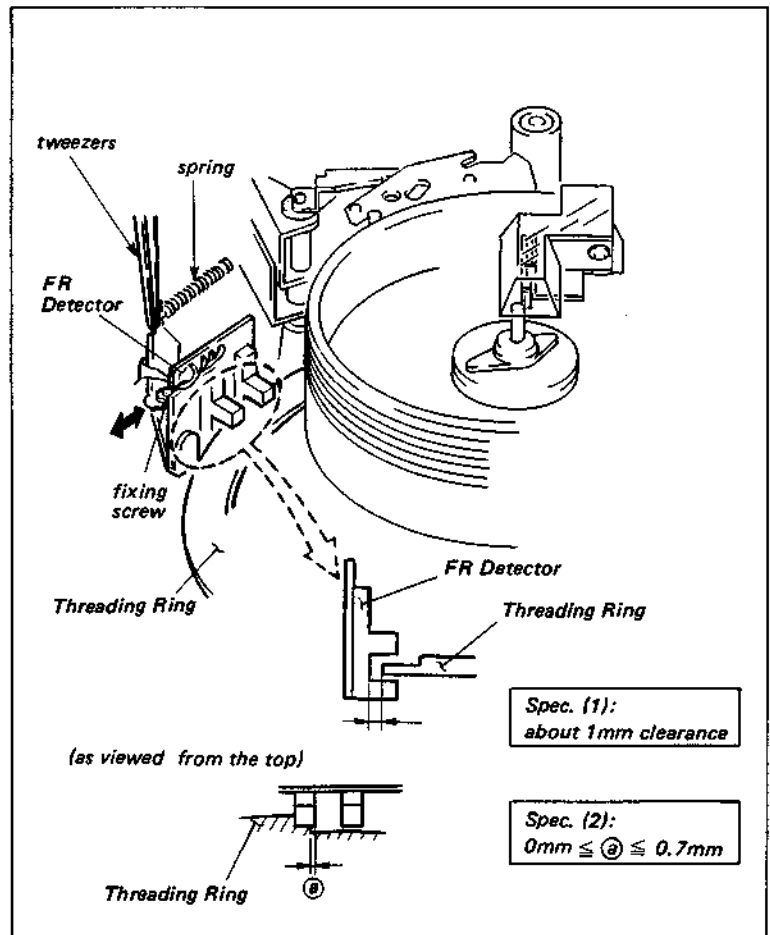

6-6. PINCH LEVER BLOCK ADJUSTMENT

6-6-1. Pinch Lever Preset Adjustment

- It is required that Section 6-5-1, Threading Ring Rotation Adjustment and Section 6-5-3, Pinch Roller Self Alignment Adjustment are correct before initiating this adjustment.

Mode: Turn the power OFF in the PLAY mode

Check procedure:

- (1) Open the RP-30A Board after removing the two fixing screws.
- (2) Put the unit into the PLAY mode and turn the power OFF. Check that the position of the Pinch Solenoid Pin meets the required specification.
- (3) Turn the power ON and press the PLAY button. After unthreading is complete, check as described in step (2).

Adjustment procedure:

- (1) Adjust the position of the Pinch Solenoid to meet the required specification, referring to Section 6-6-3, Pinch Solenoid Installing Position Adjustment.
- (2) If the specification in Step (1) cannot be obtained, adjust the position of the Sub-ring Stopper to meet the required specification, referring to Section 6-5-3, Pinch Roller Self Alignment Adjustment.
- (3) If the specification in Steps (1) and (2) cannot be obtained, insert the Pinch Lever Preset Adjustment Link into the appropriate hole of the Preset Lever Ass'y to meet the required specification. Perform Steps (1) and (2) again.

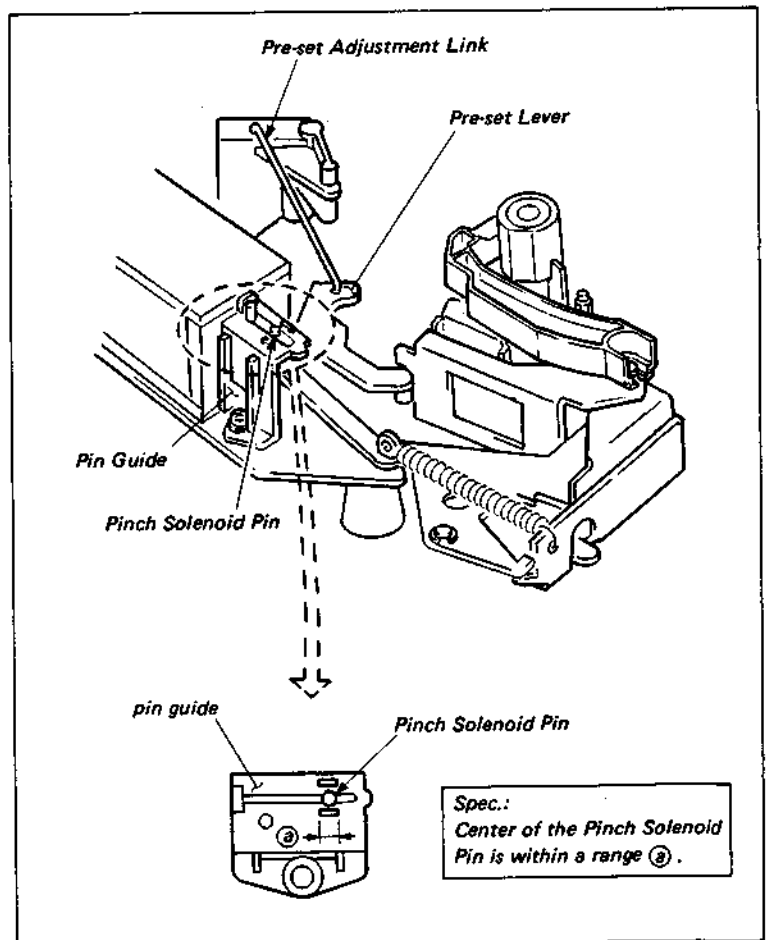

6-6-2. Pinch Roller Preset Adjustment

. It is required that Section 6-5-1, Threading Ring Rotation Adjustment and Section 6-5-3, Pinch Roller Self Alignment Adjustment are correct before initiating this adjustment.

mode: Threading completion mode without a cassette tape

Check procedure:

- (1) Put the unit into the Threading completion mode without the cassette tape.
- (2) Check that the clearance between Pinch Lever C and Pinch Lever Retainer meets the required specification.
- (3) Repeat the PLAY / STOP modes two or three times and check as described in step (2).

Adjustment procedure:

- (1) Loosen the fixing screw 1/4 to 1/2 turn.
- (2) Move the Pre-set Deck in the direction of the arrow to meet the required specification.
- (3) Tighten the fixing screw and perform the check procedures.

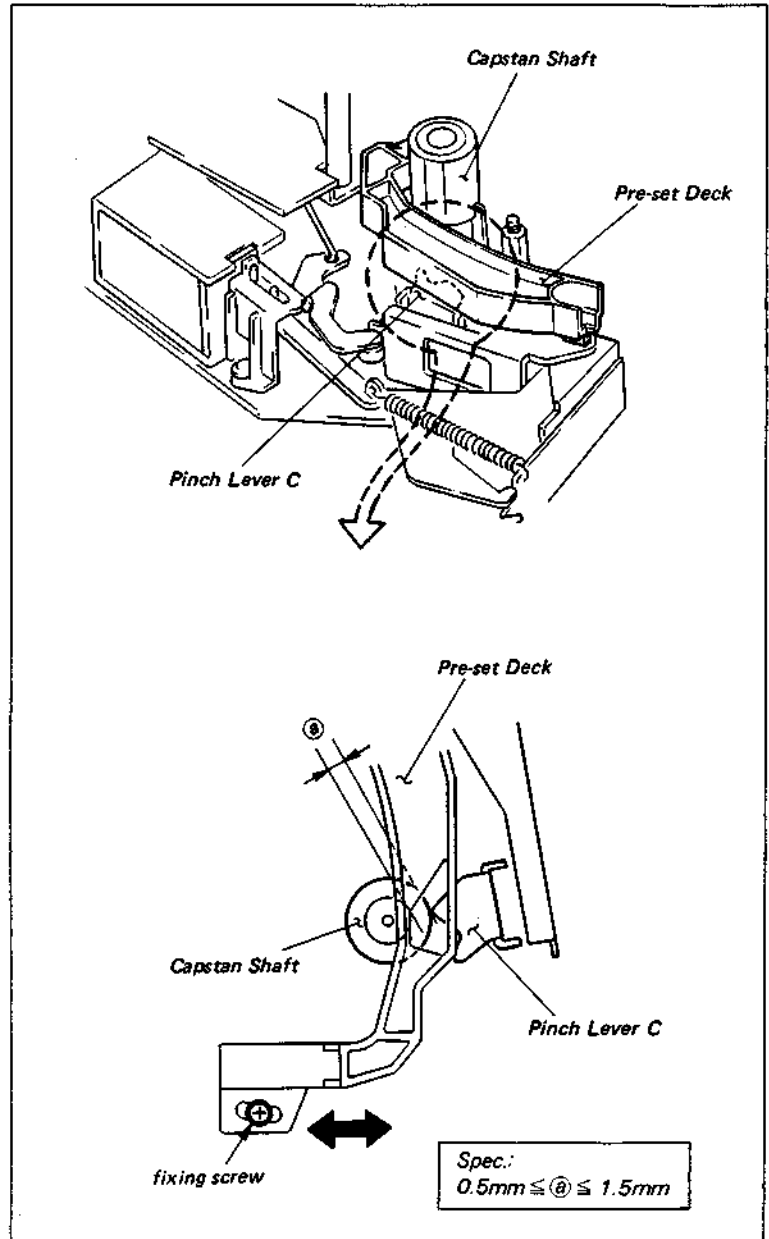

6-6-3. Pinch Solenoid Installing Position Adjustment

. This adjustment is required only when the Pinch Solenoid is replaced or removed.

Mode: PLAY mode with a cassette tape

Check procedure:

- (1) Open the RP-30A Board after removing the two fixing screws.
- (2) Insert a cassette tape and put the unit into the PLAY mode.
- (3) Check that the outer circumference of the Solenoid Pin meets the required specification.

Adjustment procedure:

- (1) Remove the E ring and the Joint Lever from the Pinch Press Lever B.
- (2) Remove the Pinch Solenoid Block from the chassis after removing the two fixing screws.
- (3) Move the Joint Lever to the fully energized position (as far as it will go in the direction of the arrow). Adjust the position of the solenoid so that the outer circumference of the Solenoid Pin to meet the required specification.
- (4) Install the Pinch Solenoid Block on the unit. Perform the check procedure.

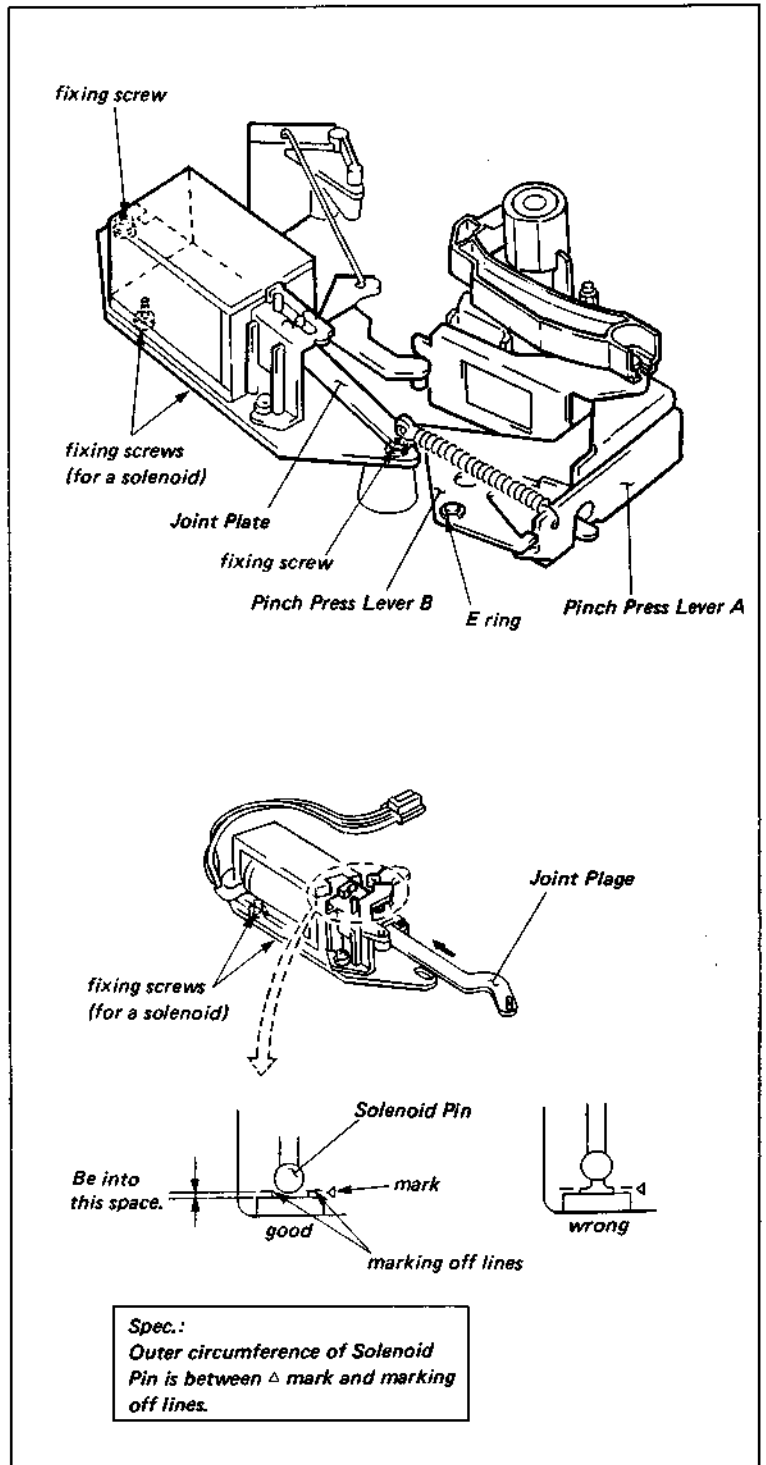

6-6-4. Pinch Solenoid Block Position Adjustment

Tool: Thickness gauge

Mode: PLAY mode with a cassette tape

Check procedure:

- (1) Insert a cassette tape and put the unit into the PLAY mode.
- (2) Check that the clearance between Pinch Press Levers A and B meets the required specification.
- (3) Repeat the unthreading and threading modes two or three times and check as described in step (2).

Adjustment procedure:

- (1) Open the RP-30A Board after removing the two fixing screws.
- (2) Put the unit into the PLAY mode. Adjust the position of the Pinch Solenoid Block with a flatblade screwdriver (3 mm dia.) to meet the required specification.
- (3) Perform the check procedures.

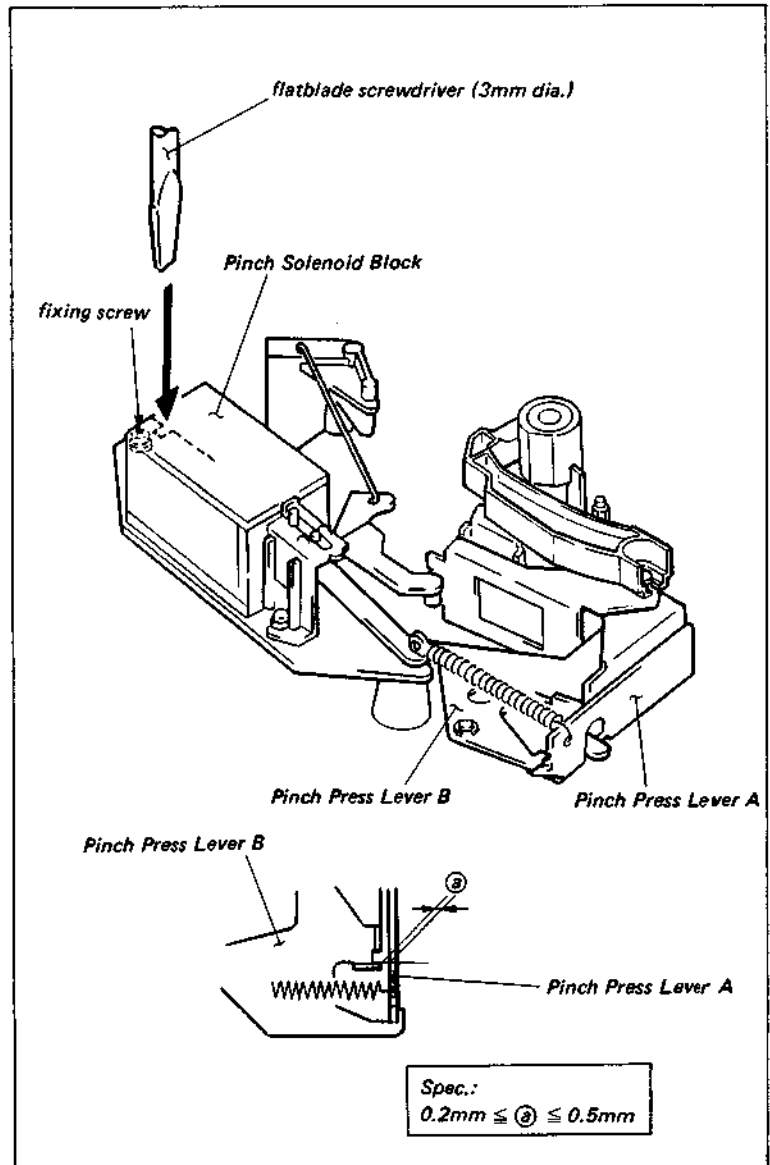

6-7. T TAPE SENSOR POSITION ADJUSTMENT

There are two adjustments in this section. The first is the height adjustment and the second is the adjustment of the clearance between the tape and LED.

Tool: Thickness gauge

Mode: PLAY mode with a cassette tape

Check procedure:

- (1) Turn the power ON. Put the unit into the PLAY mode and then put the unit into the EJECT mode. When the T Drawer Arm begins to move during unthreading, turn the power OFF. At this time, check that the clearance between the top edge of a tape and the bottom side of the T Photo Holder Block (black plastic) meets the required specification. (Spec. (1))
- (2) Put the unit into the PLAY mode.
- (3) As viewed from the top of the unit, check that the ** of the T Tape Sensor Block is above the upper flange of the T Drawer Arm (within the range "A"). (Spec. (2))

Adjustment procedure:

- (1) Bend the * with a pliers to meet the required specification (1). Perform check procedures (2) and (3).
- (2) Loosen the fixing screw of the T Tape Sensor Block 1/2 to 1 turn.
- (3) As viewed from the top of the unit in the PLAY mode, adjust the position of the T Tape Sensor Block with a flatblade screwdriver so that the ** of the T Tape Sensor Block is above the shaft of the T Drawer Arm (within the range "B").
- (4) Check that it meets the required specification (1).

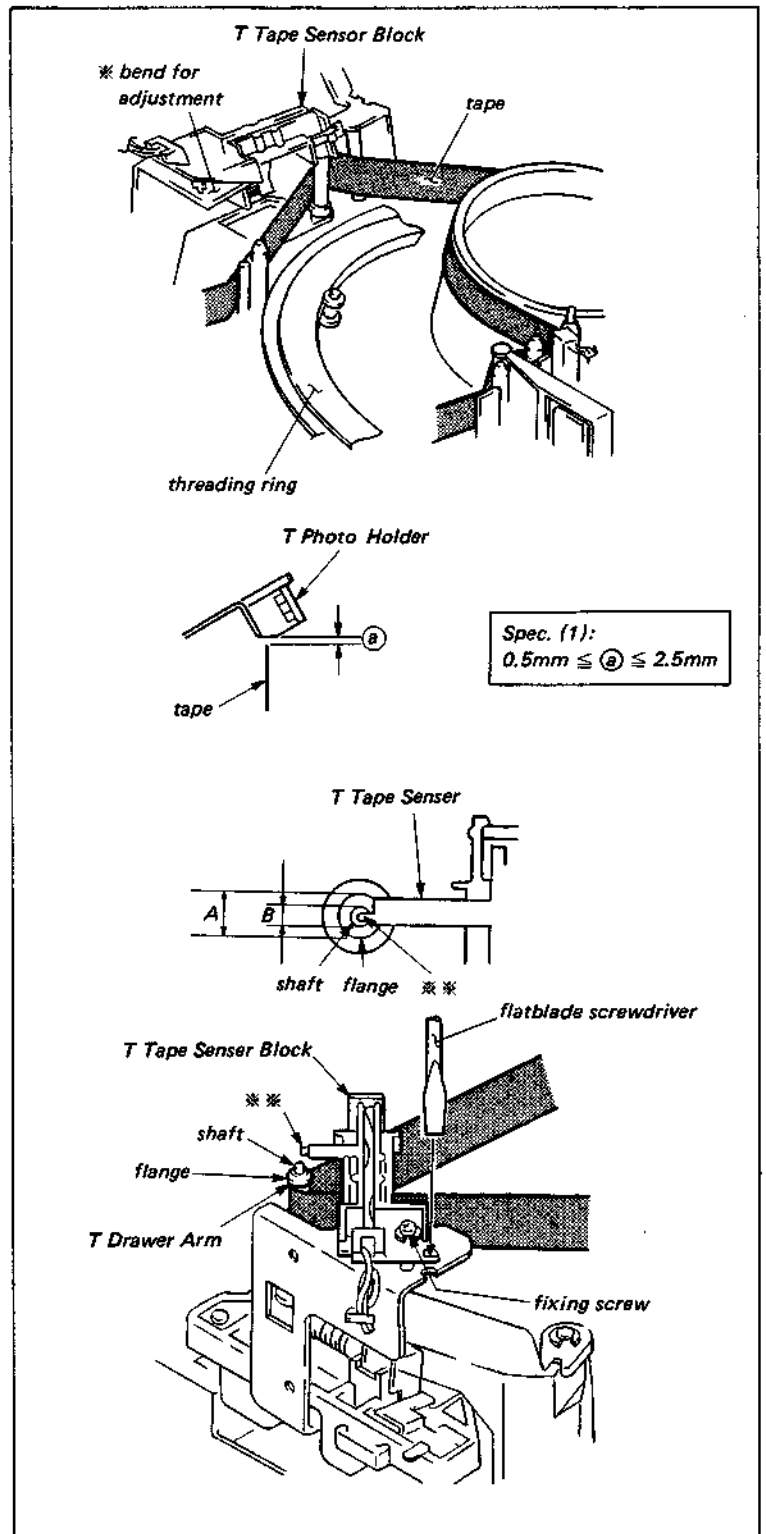

6-8. S DRAWER ROLLER BLOCK LIMITER ADJUSTMENT

Mode: Threading completion mode without a cassette tape

Check procedure:

- (1) Check that " b " of the S Drawer Spring Holder in the S Drawer Roller Block fits into notch " a " of the S Guide Holder M.

Adjustment procedure:

- (1) Loosen the fixing screw of the S Drawer Arm Ass'y 1/4 to 1/2 turn.
- (2) Adjust the position of the S Drawer Arm Ass'y with a flatblade screwdriver (3 mm dia.) to meet the required specification.

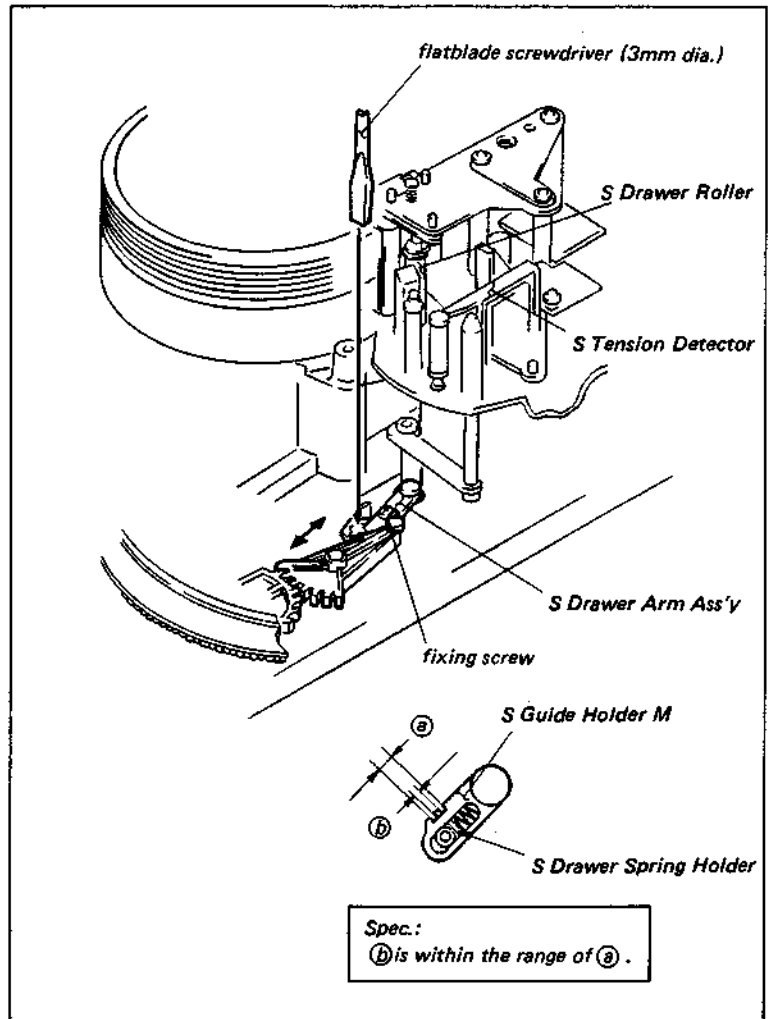

6-9. BRAKE SOLENOID POSITION ADJUSTMENT

6-9-1. T Brake Solenoid Position Adjustment

Tool: Eccentric screwdriver (6 ϕ)

Mode: PLAY mode without a cassette tape

Check procedure:

- (1) Check that the relationship between the Brake Release Arm and the Brake Arm meets the required specification.

Adjustment procedure:

- (1) Adjust the position of the T Brake Solenoid with an eccentric screwdriver to meet the required specification.

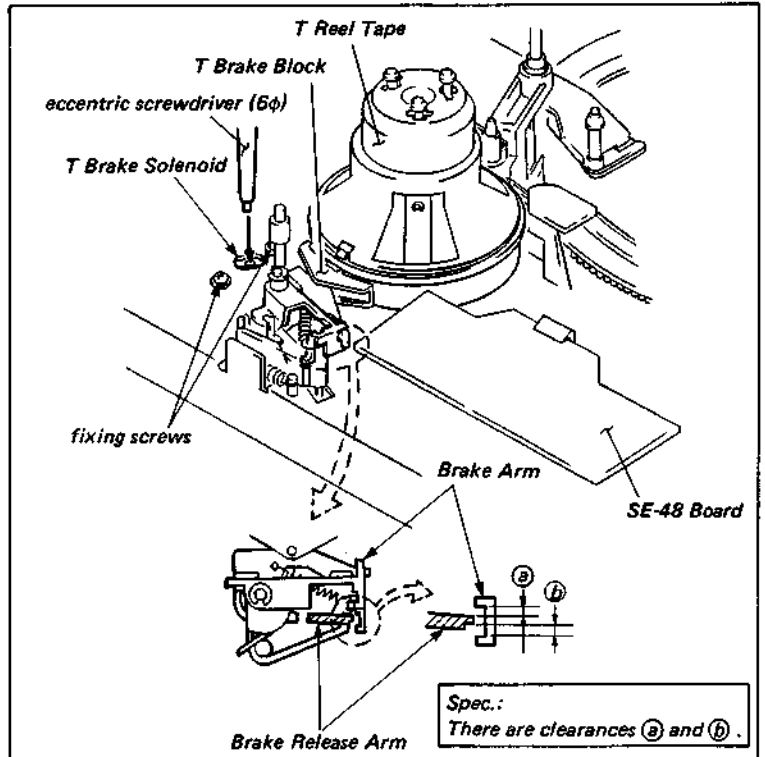

6-9-2. S Brake Solenoid Position Adjustment

Tool: Eccentric screwdriver (6 ϕ)

Mode: PLAY mode without a cassette tape

Check procedure:

- (1) Check that the relationship between the Brake Release Arm and the Brake Arm meets the required specification.

Adjustment procedure:

- (1) Adjust the position of the S Brake Solenoid with an eccentric screwdriver to meet the required specification.

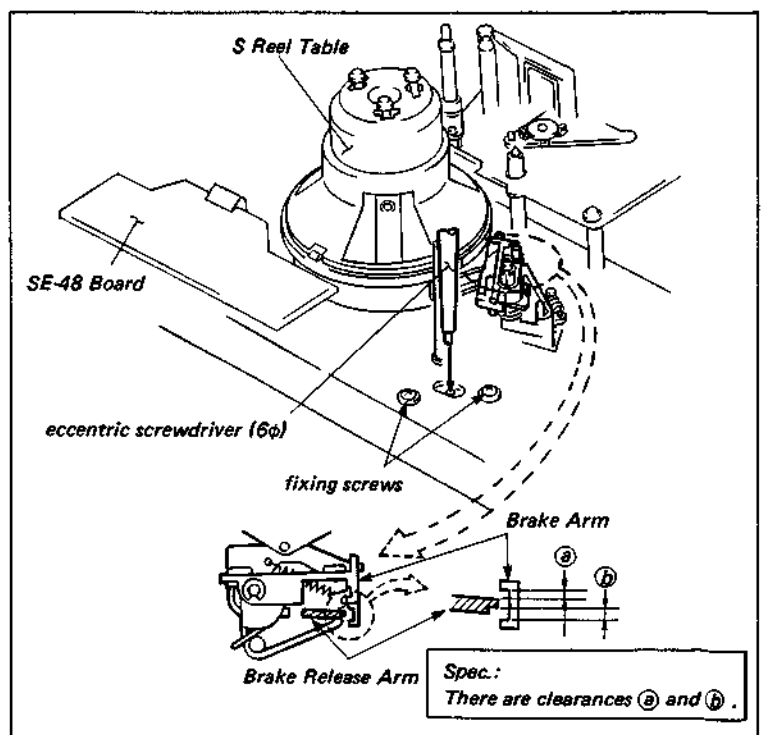

6-10. REEL TABLE ROTATION DETECTOR BLOCK POSITION ADJUSTMENT

Tool: Thickness gauge

Mode: EJECT completion mode

Check procedure:

- (1) Check that the clearances between the S/T Reel Tables and the DME on the SE-48 Board meet the required specification.

Adjustment procedure:

- (1) Loosen the two fixing screws and adjust the position of the SE-48 Board.
- (2) After adjustment, perform the check procedure.

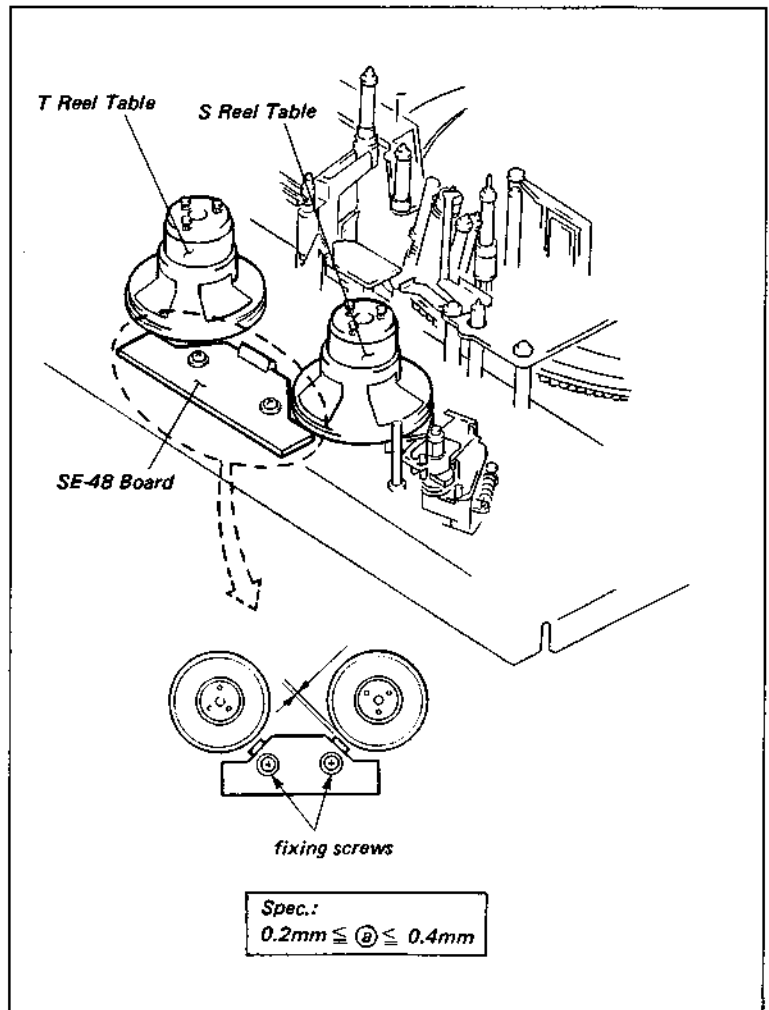

6-11. CASSETTE-UP COMPARTMENT ADJUSTMENT

- The Cassette-up Compartment has two photo-electric switches. The ON/OFF timing of these switches is adjusted in this procedures.
- Remove the Cassette-up Compartment from the unit for this adjustment.

6-11-1. Cassette-in Switch Position Adjustment

Tool: KCA type cassette tape

Circuit tester

Thickness gauge

Preparation:

- (1) Connect jumpers from the harness plug for the Cassette-up Compartment to terminals on the CC-31 / CC-36 Board as follows:

plug of harness (CN1)	terminal on CC-31/36 Board
pin 4 (5V) ←	→ pin 4/CN401
pin 5 or 2 (GND) ←	→ pin 5 or 2/CN401

- (2) Turn the power ON.

Check procedure:

- (1) Connect the circuit tester to pin 1 (H; CASSETTE IN) of CN401 on the CC-31 / CC-36 Board.
- (2) Slowly insert a KCA-60 type cassette tape.
- (3) When the circuit tester indicates "H" (about 5V), check that the clearance between the front side of the cassette tape and the bracket of the Cassette-up Compartment meets the required specification.

Adjustment procedure:

- (1) Move the Cassette-in Switch in the direction of the arrow to meet the required specification.

References:

Insert a 3.3 mm thickness gauge between the cassette tape and the bracket. Adjust the position of the Cassette-in Switch until the circuit tester indicates to "H".

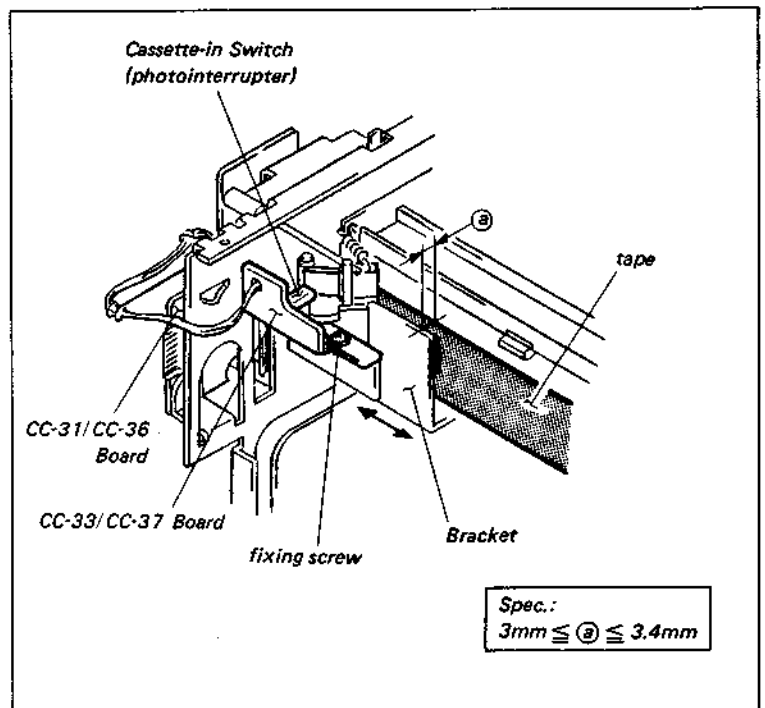

6-11-2. Cassette-down Switch Position Adjustment

Tool: Circuit tester

Preparation:

- (1) Connect jumpers from the harness plug of the Cassette-up Compartment to terminal on the CC-31 / CC-36 Board as follows:

plug of harness (CN1)	terminal on CC-31/36 Board
pin 4 (5V) ←	→ pin 4/CN401
pin 5 or 2 (GND) ←	→ pin 5 of 2/CN401

- (2) Turn the power ON.

Check procedure:

- (1) Connect the circuit tester to pin 3 (H; CASSETTE DOWN) of CN401 on the CC-31 / CC-36 Board.
- (2) Insert a KCA-60 type cassette tape and turn the white gear slowly in the direction of the arrow.
- (3) When the circuit tester indicates "H", check that the clearance between the roller and the guide meets the required specification.

Adjustment procedure:

- (1) Move the Cassette-down switch in the direction of the arrow to meet the required specification.

Reference:

Turn the white gear on the right side until the clearance between the roller and the guide is 2.2 mm. Adjust the position of the Cassette-down Switch so that the circuit tester indicates "H" in this position.

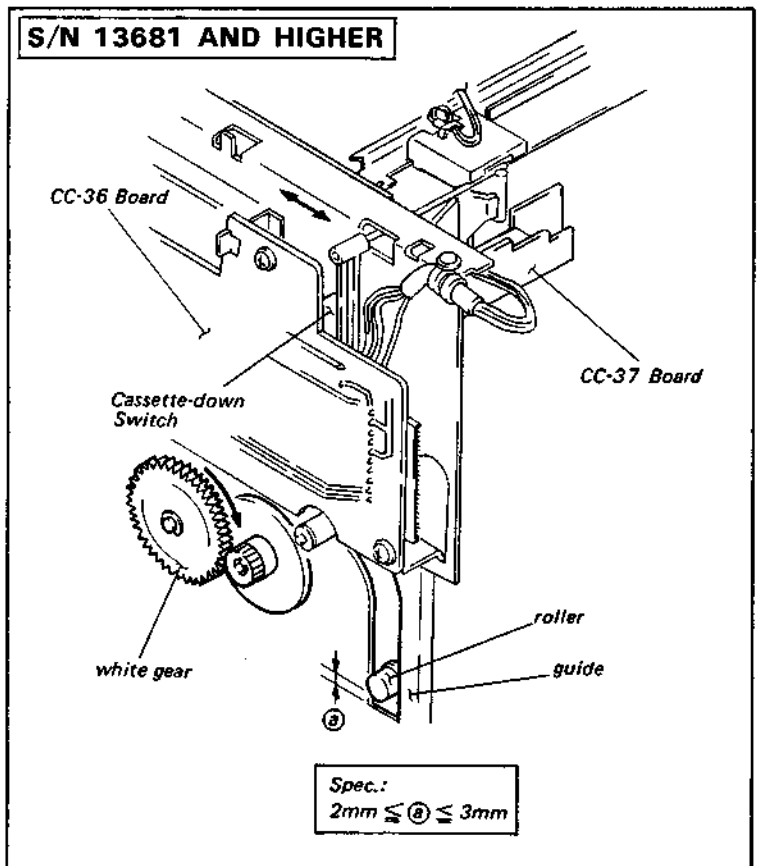
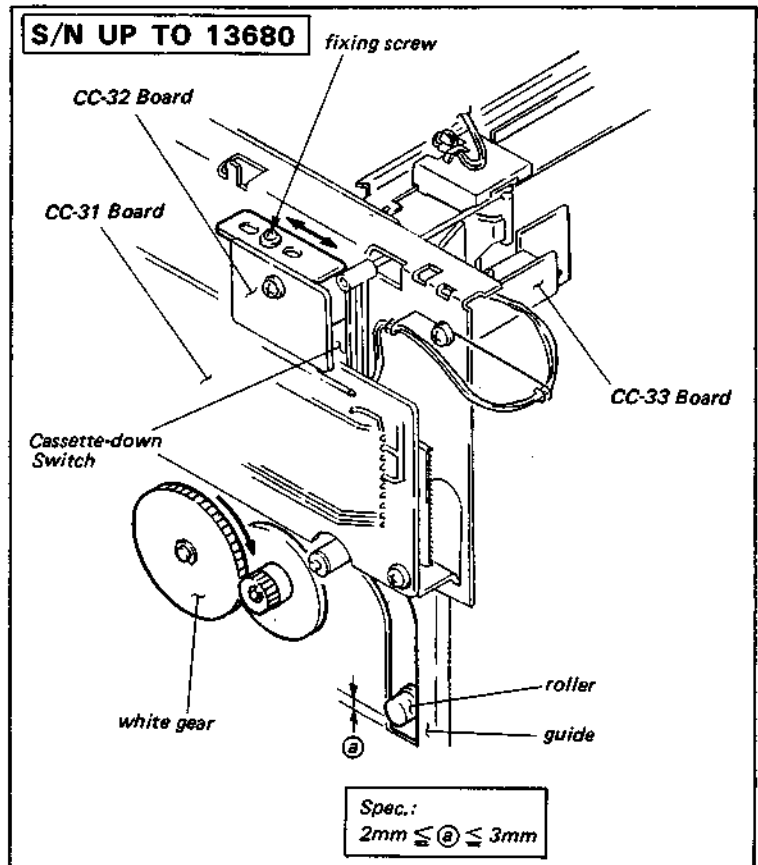

6-12. LEAF SPRING POSITION ADJUSTMENT

Check procedure:

- (1) Put the unit into the PLAY mode without a cassette tape, and then put the unit into the EJECT mode.
- (2) Turn the Pulley of the Gear Box by hand until the edge of the T Drawer Arm is at the center of the shaft as shown in the figure.
- (3) Check that the clearance between the Leaf Spring and the Pinch Roller Shaft meets the required specification (1).
- (4) Put the unit into the PLAY mode without a cassette tape, and then put the unit into the EJECT completion mode.
- (5) Check that the Leaf Spring touches the Pinch Roller Shaft, and that the clearance between the Leaf Spring and the Pinch Roller meets the required specification (2).

Adjustment procedure:

- (1) Adjust the position of the Leaf Spring to meet the required specifications (1) and (2). If specification (2) cannot be obtained, bend the * of the Leaf Spring to meet the required specification.

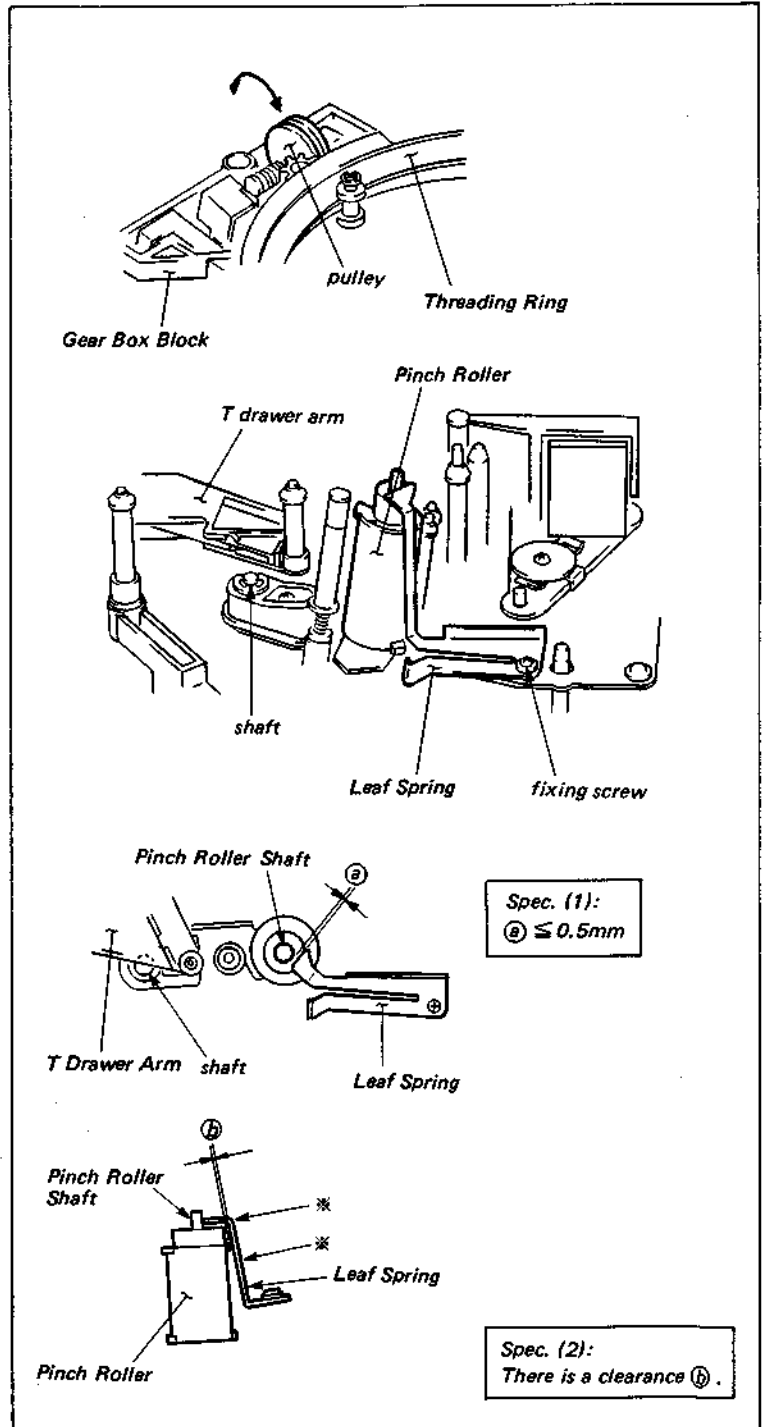

6-13. SLIP-RING BLOCK BRUSH POSITION ADJUSTMENT

Adjustment procedure:

- (1) Loosen the two fixing screws of the Brush Bracket 1/2 to 1 turn.
- (2) Position the brush on the ring to meet the required specification, and then tighten the fixing screws.

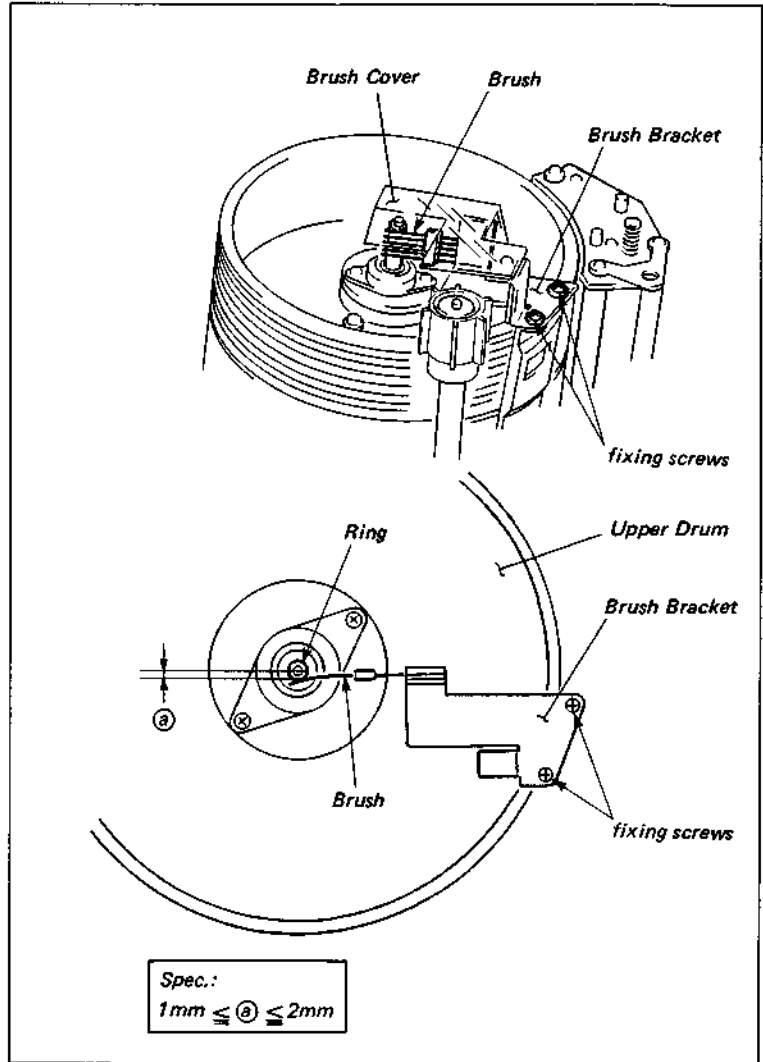

SECTION 7 TORQUE SYSTEM ALIGNMENT

7-1. S BRAKE TORQUE ADJUSTMENT

Tool: Reel table torque measurement tape
(100 mm dia.)

Tension scale (200 g full scale)

Mode: EJECT completion / power OFF mode

Check procedure:

- (1) Remove the spring and release the Sub Brake.
- (2) Grasp the top of the S Reel Table. While turning it in the clockwise direction approx. 30 degrees, check that the clearance between the Brake Arm and the Lining Holder meets the required specification (1) as shown in the figure.
- (3) Place the jig tape on the S Reel Table and hook a tension scale to the end of the jig tape. Pull out the tape at a constant speed of approx. 9.5cm/sec. in the direction of the arrow. Check that the scale reading meets the required specification (2).
- (4) If meets the required specification, hook the spring of the Sub Brake.

Adjustment procedure:

For Spec. (1)

- (1) Bend the Brake Block Shaft toward the reel table (or in the opposite direction) by hand.

For Spec. (2)

- (2) Clean the surface of the reel table with a cloth moistened with cleaning fluid.
- (3) If does not meet the specification (2), replace the Lining Holder and check again.
- (4) If does not meet the specification in Step (3), replace the reel table and check again.
- (5) After adjustment, hook the spring of the Sub Brake.

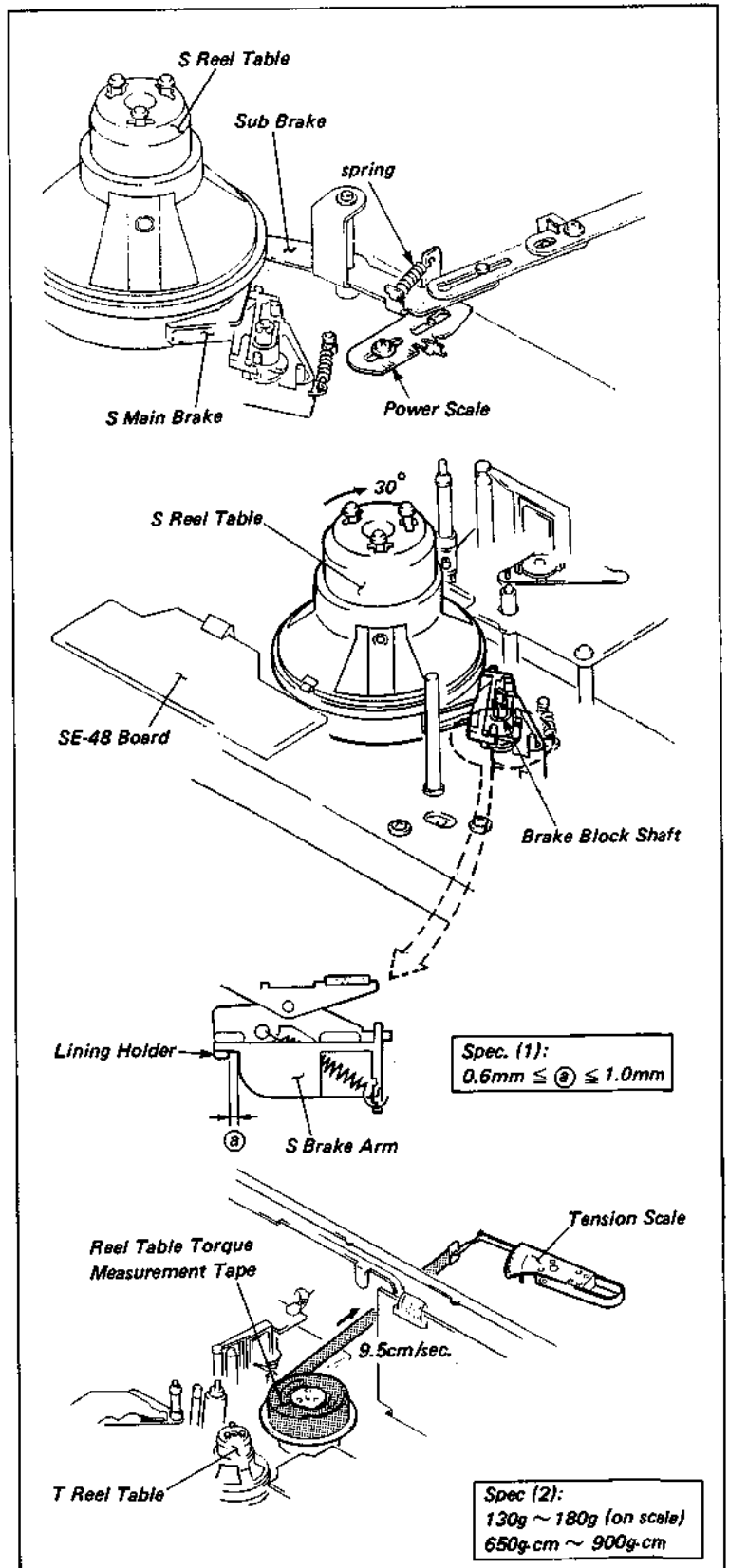

7-2. T BRAKE TORQUE ADJUSTMENT

Tool: Reel table torque measurement tape
(100 mm dia.)

Tension scale (200 g full scale)

Mode: EJECT completion / power OFF mode

Check procedure:

- (1) Grasp the top of the T Reel Table. While turning it in the clockwise direction approx. 30 degrees, check that the clearance between the Brake Arm and the Lining Holder meets the required specification (1) as shown in the figure.
- (2) Install the jig tape on the T Reel Table and hook a tension scale to the end of the jig tape. Pull out the tape at a constant speed of approx. 9.5cm/sec. in the direction of the arrow. Check that the scale reading meets the required specification (2).

Adjustment procedure:

For Spec. (1)

- (1) Bend the Brake Block Shaft toward the reel table (or in the opposite direction) by hand.

For Spec. (2)

- (2) Clean the surface of the reel table with a cloth moistened with cleaning fluid.
- (3) If does not meet the specification (2), replace the Lining Holder and check again.
- (4) If does not meet the specification in Step (3), replace the reel table and check again.

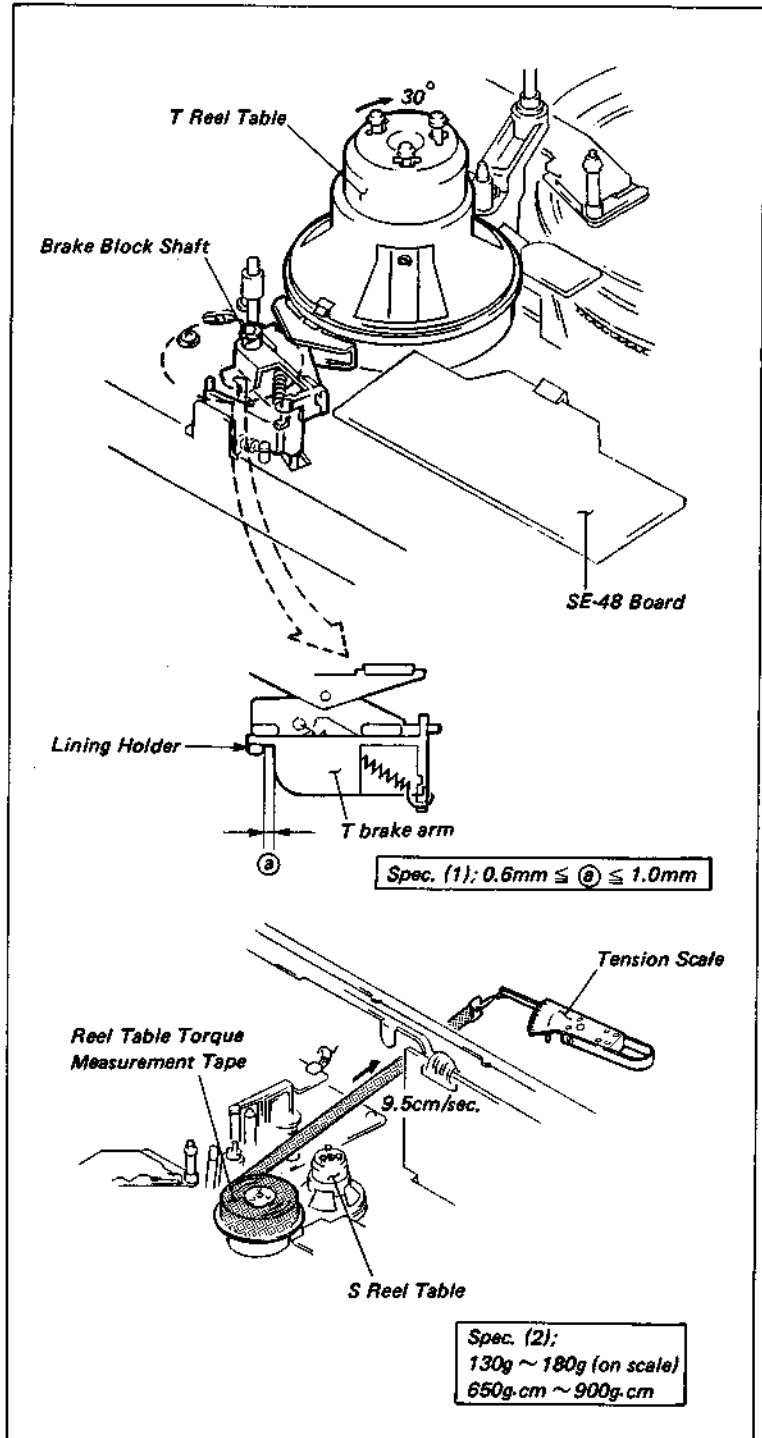

7-3. SUB BRAKE ADJUSTMENT

7-3-1. Sub Brake Torque Adjustment

Tool: Reel table torque measurement tape
(100 mm dia.)

Tension scale (200 g full scale)

Mode: EJECT completion / POWER OFF

Check procedure:

- (1) Remove the spring of the S Main Brake from the shaft.
- (2) Install the jig tape on the S Reel Table and hook a tension scale to the end of the jig tape. Pull out the tape at a constant speed of approx. 9.5cm/sec. in the direction of the arrow. Check that the scale reading meets the required specification.
- (3) When the scale reading is within the specification, hook the spring to the shaft as it was before.

Adjustment procedure:

- (1) Clean the surface of the reel table with a cloth moistened with cleaning fluid.
- (2) Loosen the fixing screw of the Power Scale 1/4 to 1/2 turn.
- (3) Inset a flatblade screwdriver in the adjustment hole and adjust the position of the Power Scale.

. If the scale reading is more than the specification, move the Power Scale in the direction of arrow A.

. Reference:

One scale (1 mm) of the Power Scale changes the tension reading about 20 g (100g - cm).

- (4) After adjustment, hook the spring to the shaft as it was before.

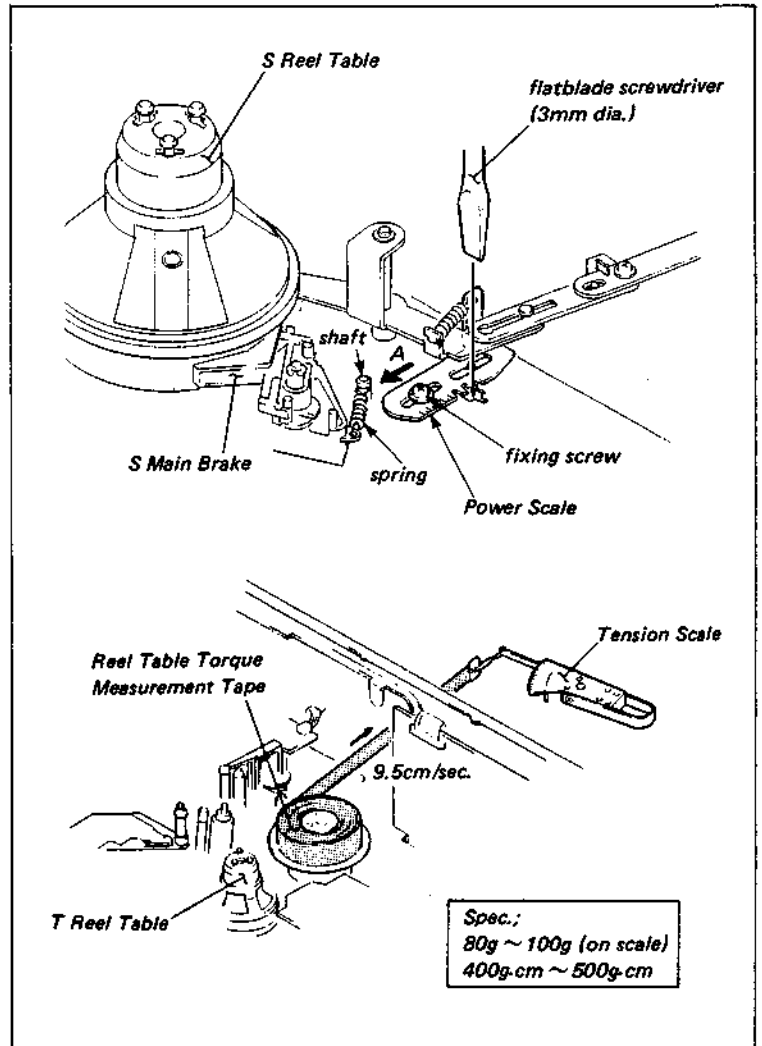

7-3-2. Sub Brake Release Adjustment

Mode: Threading completion mode
(POWER OFF)

Check procedure:

- (1) Put the unit into the Threading completion mode.
- (2) Check that the Sub Brake is released from the S Reel Table.

Adjustment procedure:

- (1) Put the unit into the Threading completion mode and turn the Power OFF.
- (2) Move the Threading Ring in the direction of the arrow by turning the pully of the gear box block to meet the required specification.
- (3) Loosen the fixing screw of the Brake Release Link (A).
- (4) Push the Brake Release Link (A) in the direction of the arrow until the notch touches the shaft as shown in the figure. Tighten the fixing screw.
- (5) Perform the check procedure.

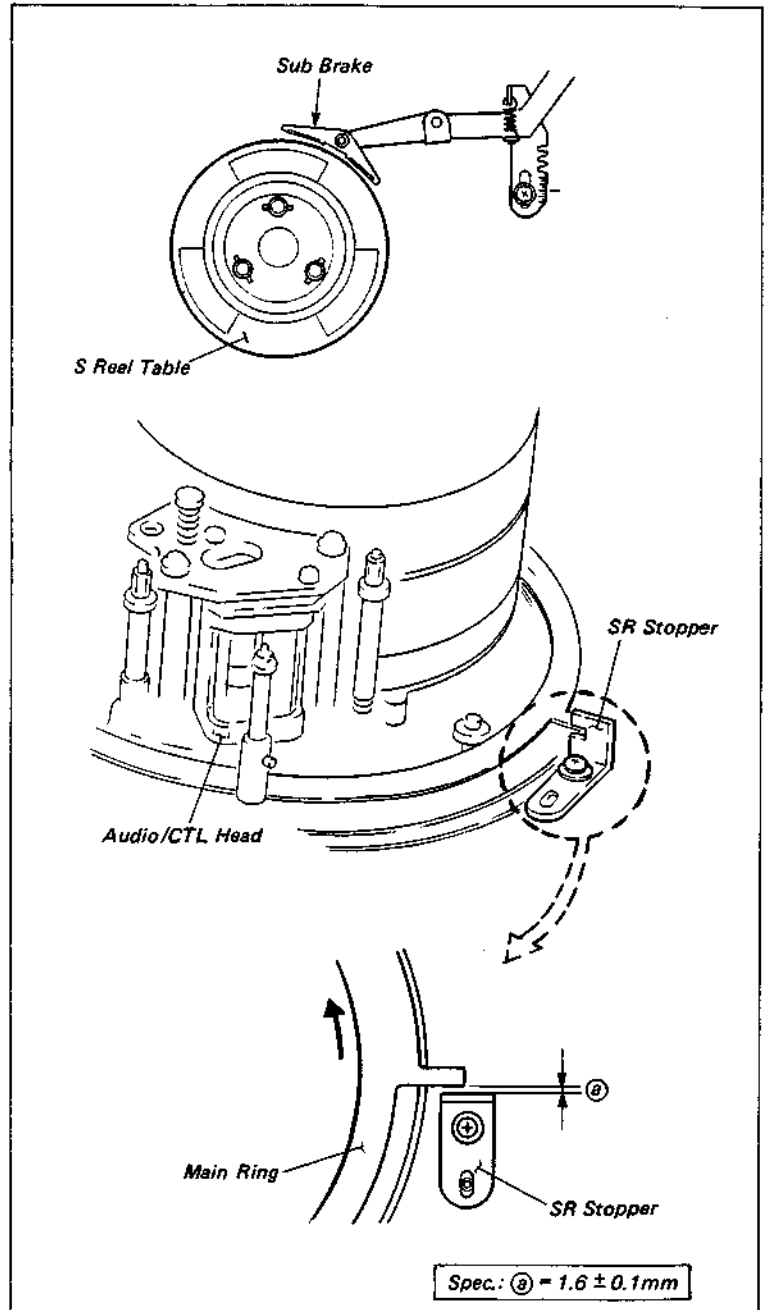

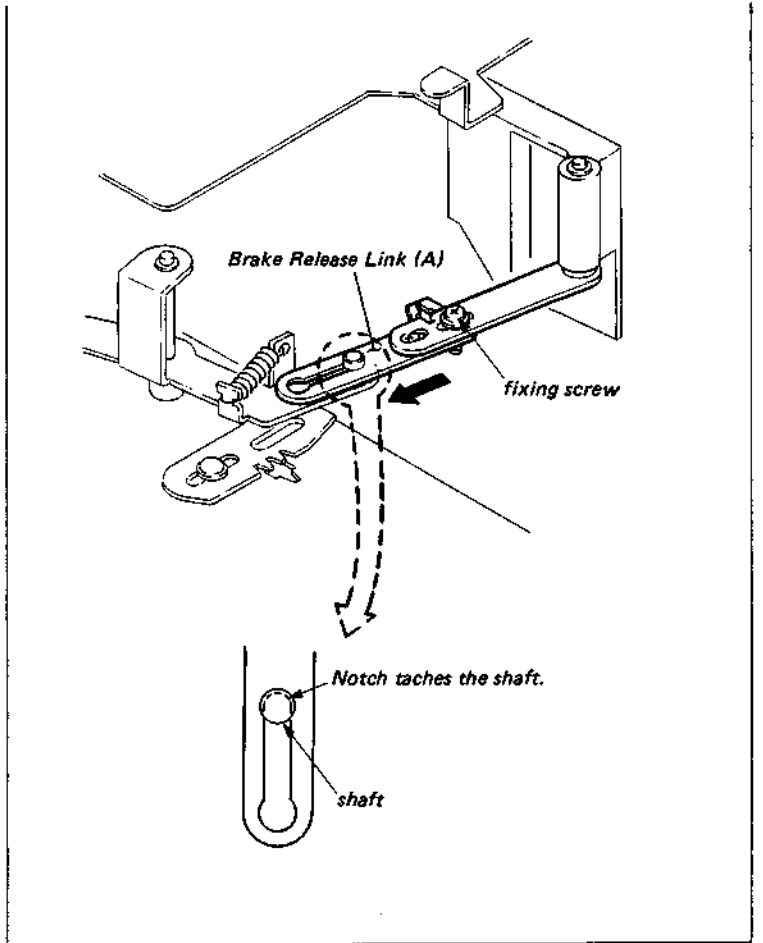

S/N UP TO 13730

7-4. REEL MOTOR CURRENT SENSITIVE ADJUSTMENT

7-4-1. S Reel Motor Current Sensitive Adjustment

Tool: Reel table torque measurement tape
(100 mm dia.)
Tension scale (500 g full scale)
Extension board (EX-128, EX-127)

Mode: STANDBY ON mode

Check procedure:

- (1) Set the Bit 5, Bit 6, Bit 7 of S201 and S202 on the SV-88A Board to ON.
- (2) Turn the POWER ON.
- (3) Put the unit into the Threading completion mode, press the STANDBY button.
- (4) Place the jig tape on the S Reel Table and hook the tension scale to the end of the jig tape. Pull out the tape as shown in the figure.
- (5) Press the STANDBY button and put the unit into the STANDBY ON mode. Check that the scale reading meets the required specification.
- (6) If it meets the required specification, press the STANDBY button and then remove the jig tape. Put the unit into the Threading completion mode, set the Bit 5, Bit 6, Bit 7 of S201 and S202 on the SV-88A Board to OFF.

Adjustment procedure:

- (1) Extend the DR-53 Board with an extension board. Adjust the RV2 to meet the required specification.
- (2) After adjustment, press the STANDBY button and remove the jig tape. Put the unit into the Threading completion mode, set the Bit 5, Bit 6, Bit 7 of S201 and S202 on the SV-88A Board to OFF.

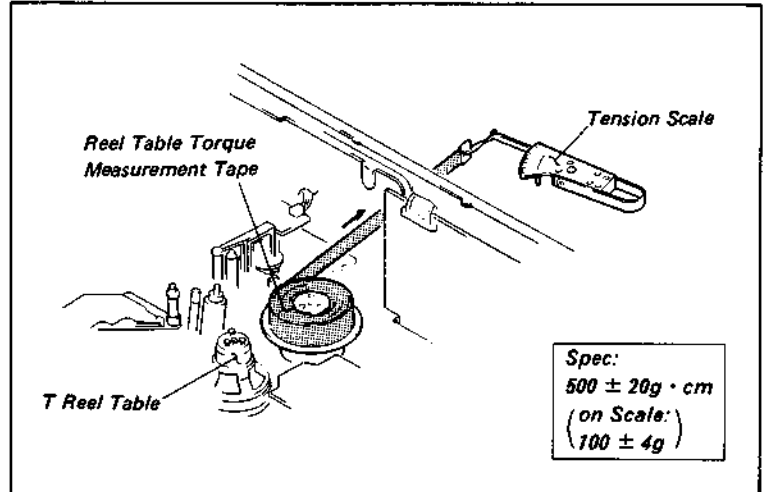

S/N 13731 AND HIGHER

7-4. REEL MOTOR CURRENT SENSITIVE ADJUSTMENT

7-4-1. S Reel Motor Current Sensitive Adjustment

Tools: Reel table torque measurement tape
(100 mm dia.)
Tension scale (500 g full scale)
Extension board (EX-128, EX-127)

Mode: STANDBY ON mode

Check procedure:

- (1) Set the Bit 5, Bit 6 of S101 and S301 on the SV-113 Board to ON.
- (2) Turn the POWER ON.
- (3) Put the unit into the Threading completion mode, press the STANDBY button.
- (4) Place the jig tape on the S Reel Table and hook the tension scale to the end of the jig tape. Pull out the tape as shown in the figure.
- (5) Press the STANDBY button and put the unit into the STANDBY ON mode. Check that the scale reading meets the required specification.
- (6) If it meets the required specification, press the STANDBY button and then remove the jig tape. Put the unit into the Threading completion mode, set the Bit 5, Bit 6 of S101 and S301 on the SV-113 Board to OFF.

Adjustment procedure:

- (1) Extend the DR-53 Board with an extension board. Adjust the RV2 to meet the required specification.
- (2) After adjustment, press the STANDBY button and remove the jig tape. Put the unit into the Threading completion mode, set the Bit 5, Bit 6, of S101 and S301 on the SV-113 Board to OFF.

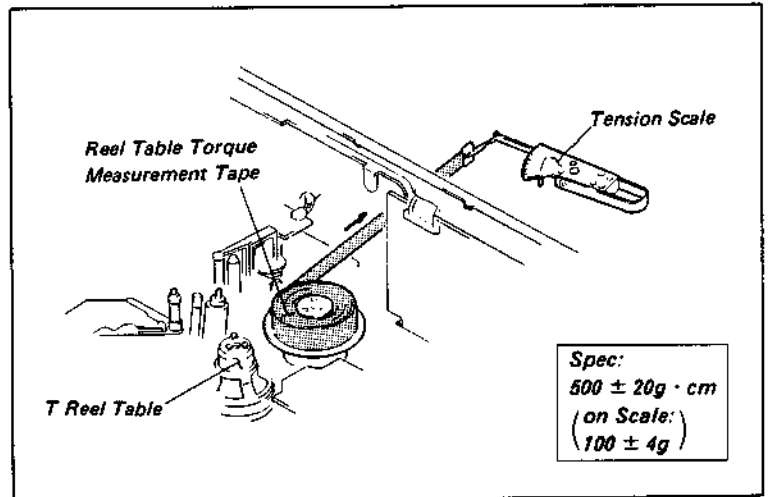

S/N UP TO 13730

7-4-2. T Reel Motor Current Sensitive Adjustment

Tools: Reel table torque measurement tape
(100 mm dia.)
Tension scale (500 g full scale)
Extension board (EX-128, EX-127)

Modes: STANDBY ON mode

Check procedure:

- (1) Set the Bit 5, Bit 6, Bit 7 of S201 and S202 on the SV-88A Board to ON.
- (2) Turn the POWER ON.
- (3) Put the unit into the Threading completion mode, press the STANDBY button.
- (4) Place the jig tape on the T Reel Table and hook the tension scale to the end of the jig tape. Pull out the tape as shown in the figure.
- (5) Press the STANDBY button and put the unit into the STANDBY ON mode. Check that the scale reading meets the required specification.
- (6) If it meets the required specification, press the STANDBY button and then remove the jig tape. Put the unit into the Threading completion mode, set the Bit 5, Bit 6, Bit 7 of S201 and S202 on the SV-88A Board to OFF.

Adjustment procedure:

- (1) Extend the DR-53 Board with an extension board. Adjust the RV1 to meet the required specification.
- (2) After adjustment, press the STANDBY button and remove the jig tape. Put the unit into the Threading completion mode, set the Bit 5, Bit 6, Bit 7 of S201 and S202 on the SV-88A Board to OFF.

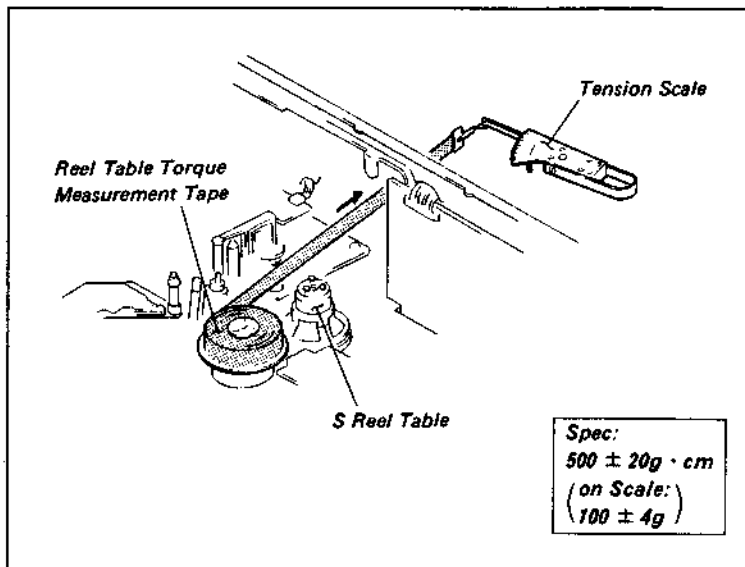

S/N 13731 AND HIGHER

7-4-2. T Reel Motor Current Sensitive Adjustment

Tools: Reel table torque measurement tape
(100 mm dia.)
Tension scale (500 g full scale)
Extension board (EX-128, EX-127)

Mode: STANDBY ON mode

Check procedure:

- (1) Set the Bit 5, Bit 6 of S101 and S301 on the SV-113 Board to ON.
- (2) Turn the POWER ON.
- (3) Put the unit into the Threading completion mode, press the STANDBY button.
- (4) Place the jig tape on the T Reel Table and hook the tension scale to the end of the jig tape. Pull out the tape as shown in the figure.
- (5) Press the STANDBY button and put the unit into the STANDBY ON mode. Check that the scale reading meets the required specification.
- (6) If it meets the required specification, press the STANDBY button and then remove the jig tape. Put the unit into the Threading completion mode, set the Bit 5, Bit 6 of S101 and S301 on the SV-113 Board to OFF.

Adjustment procedure:

- (1) Extend the DR-53 Board with an extension board. Adjust the RV1 to meet the required specification.
- (2) After adjustment, press the STANDBY button and remove the jig tape. Put the unit into the Threading completion mode. set the Bit 5, Bit 6 of S101 and S301 on the SV-113 Board to OFF.

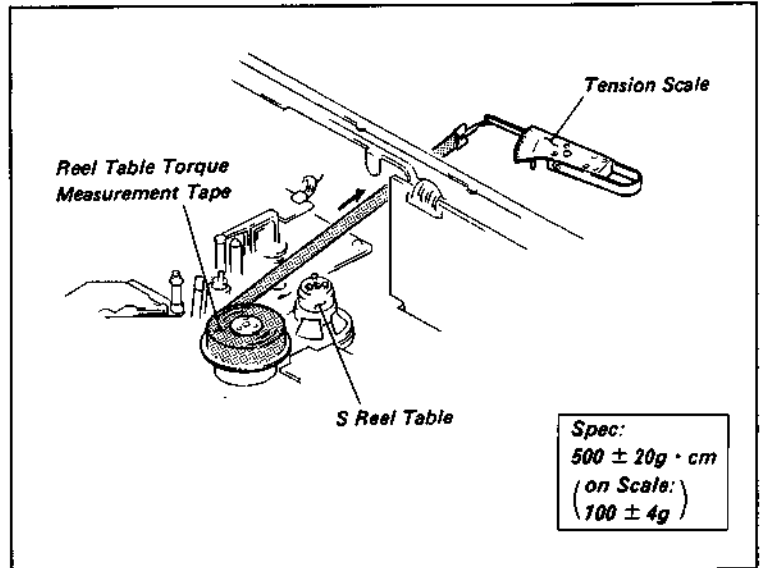

S/N UP TO 13730

7-5. FWD BACK TENSION ADJUSTMENT

Tool: Back tension measurement special cassette tape

This cassette should be prepared as follows:

Wind up tape to the S Reel and remove the * marked seven fixing screws on the back of the cassette as shown in the figure. Remove the upper half of the cassette. (fig.1) Cut the cassette tape and put a piece of adhesive tape on the end of the cassette tape, and then make a hole through it. Lace a piece of string through the hole and tie a small loop. (fig.2)

Tension scale (100 g full scale)

Extension board (EX-128)

Preparation:

(1) Set the Bit 7 of S201 on the SV-88A Board to ON. Short between TP10 and E1 on the SY-102A Board with a shorting clip from the entrance of the Time Code Board.

Check procedure:

- (1) Turn the SKEW control knob to center detent portion.
- (2) Place the special cassette tape on the reel tables and pull out the tape as shown in the figure.
- (3) Hold the special tape with a hand securely at the position as shown in the figure. Turn the power ON and put the unit into the STOP mode.
- (4) Put the unit into the STANDBY OFF mode and hook the tension scale to the end of the special tape. Be sure that the tape does not curl at the upper or lower flange of the S Drawer Roller.

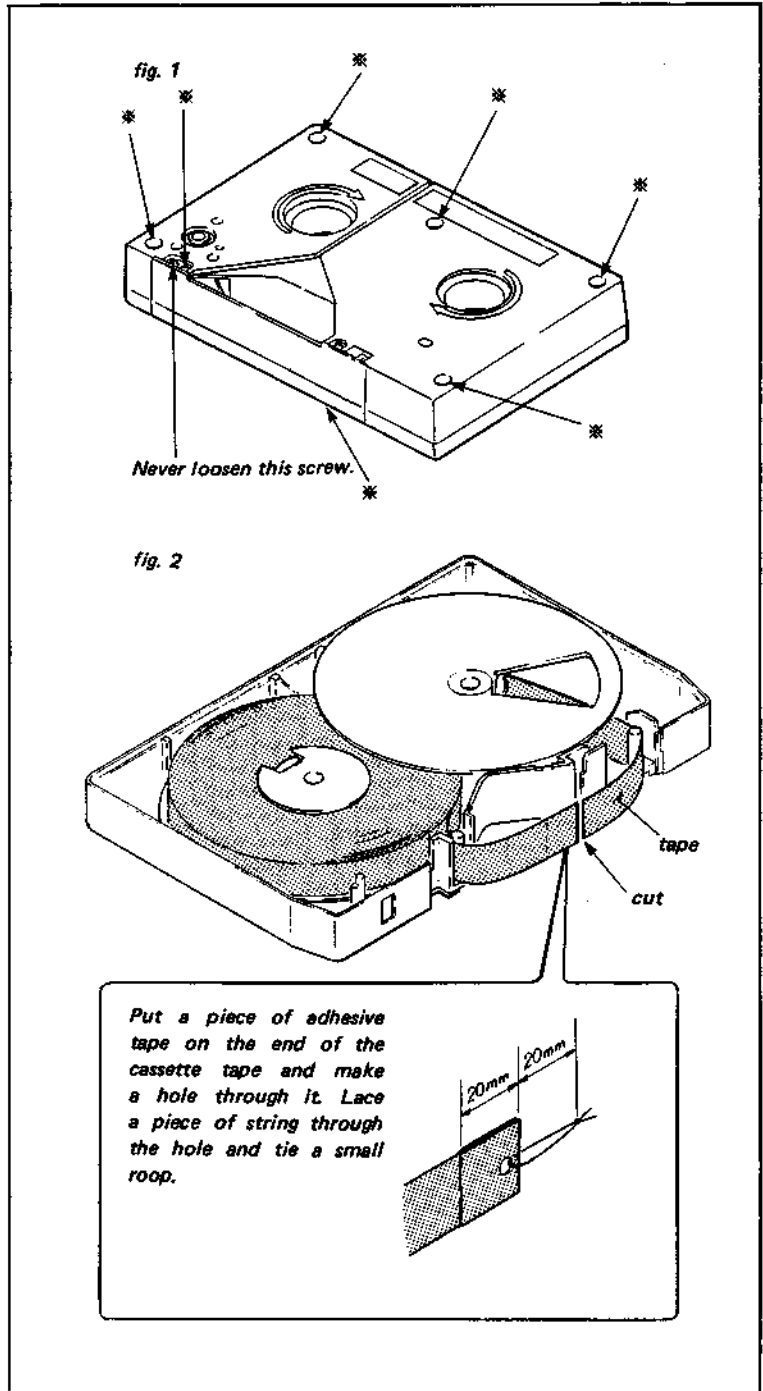

S/N 13731 AND HIGHER

7-5. FWD BACK TENSION ADJUSTMENT

Tool: Back tension measurement special cassette tape

This cassette should be prepared as follows:

- Wind up tape to the S Reel and remove the * marked seven fixing screws on the back of the cassette as shown in the figure. Remove the upper half of the cassette. (fig.1) Cut the cassette tape and put a piece of adhesive tape on the end of the cassette tape, and then make a hole through it. Lace a piece of string through the hole and tie a small loop. (fig.2)

Tension scale (100 g full scale)

Extension board (EX-128)

Preparation:

- (1) Set the Bit 7 of S101 on the SV-113 Board to ON. Short between TP10 and E1 on the SY-102A Board with a shorting clip from the entrance of the Time Code Board.

Check procedure:

- (1) Turn the SKEW control knob to center detent portion.
- (2) Place the special cassette tape on the reel tables and pull out the tape as shown in the figure.
- (3) Hold the special tape with a hand securely at the position as shown in the figure. Turn the power ON and put the unit into the STOP mode.
- (4) Put the unit into the STANDBY OFF mode and hook the tension scale to the end of the special tape. Be sure that the tape does not curl at the upper or lower flange of the S Drawer Roller.

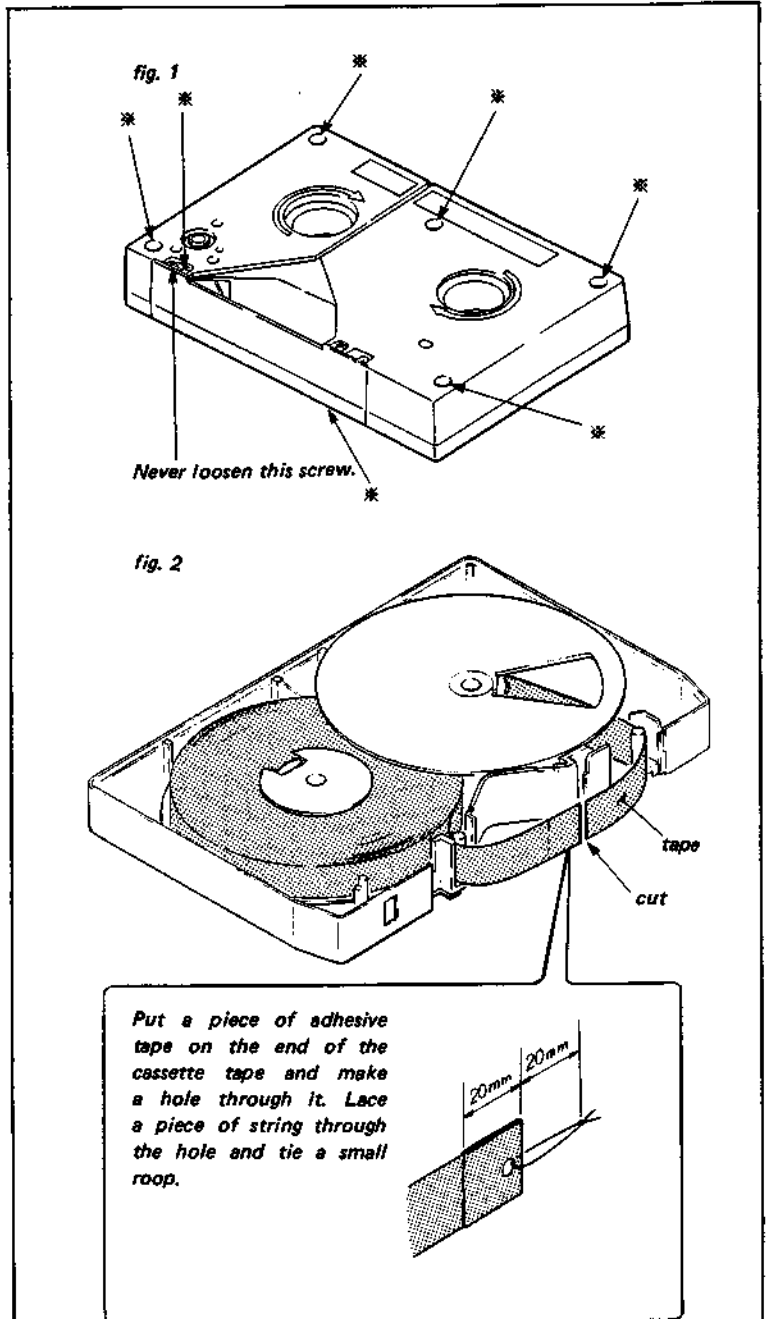

S/N UP TO 13730

- (5) Put the unit into the PLAY mode. Pull out the tape at a constant speed of approx. 1cm/sec. in the direction of the arrow. Check that the scale reading meets the required specification.
- (6) If it is within the specification, put the unit into the STANDBY OFF mode. Remove the tension scale from the special tape.
- (7) Remove the special tape from the reel tables and put the unit into the EJECT mode.
- (8) Set the Bit 7 of S201 on the SV-88A Board to OFF and remove the shorting clip from the SY-102A Board.

Adjustment procedure:

- (1) Adjust the RV401 on the SV-88A Board to meet the required specification.

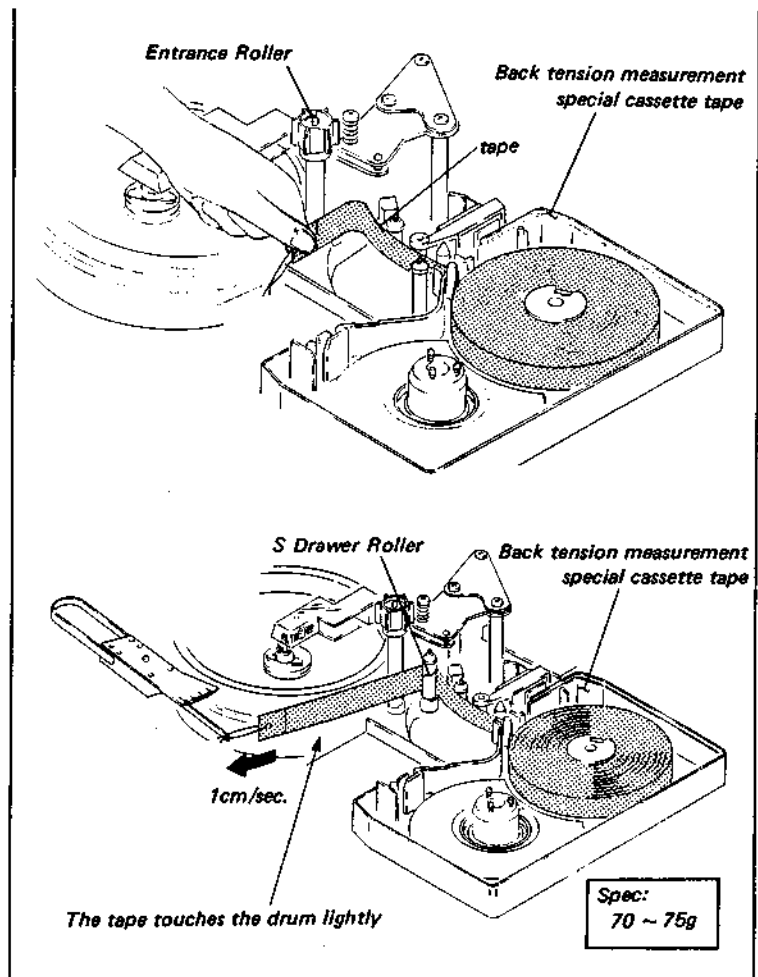

S/N 13731 AND HIGHER

- (5) Put the unit into the PLAY mode. Pull out the tape at a constant speed of approx. 1cm/sec. in the direction of the arrow. Check that the scale reading meets the required specification.
- (6) If it is within the specification, put the unit into the STANDBY OFF mode. Remove the tension scale from the special tape.
- (7) Remove the special tape from the reel tables and put the unit into the EJECT mode.
- (8) Set the Bit 7 of S101 on the SV-113 Board to OFF and remove the shorting clip from the SY-102A Board.

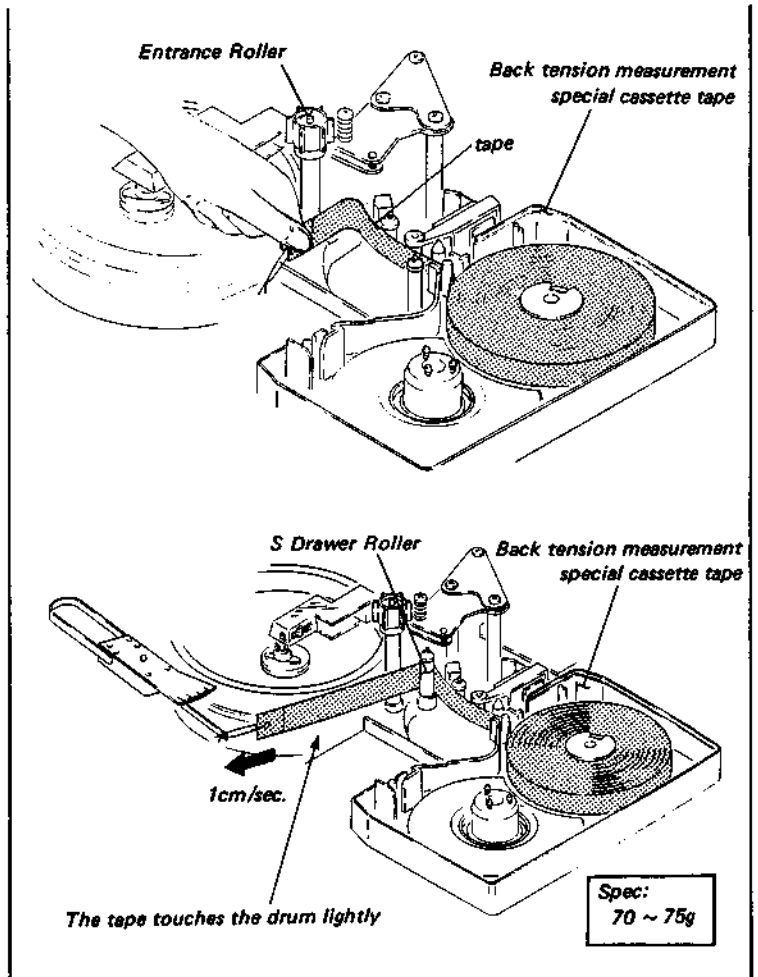

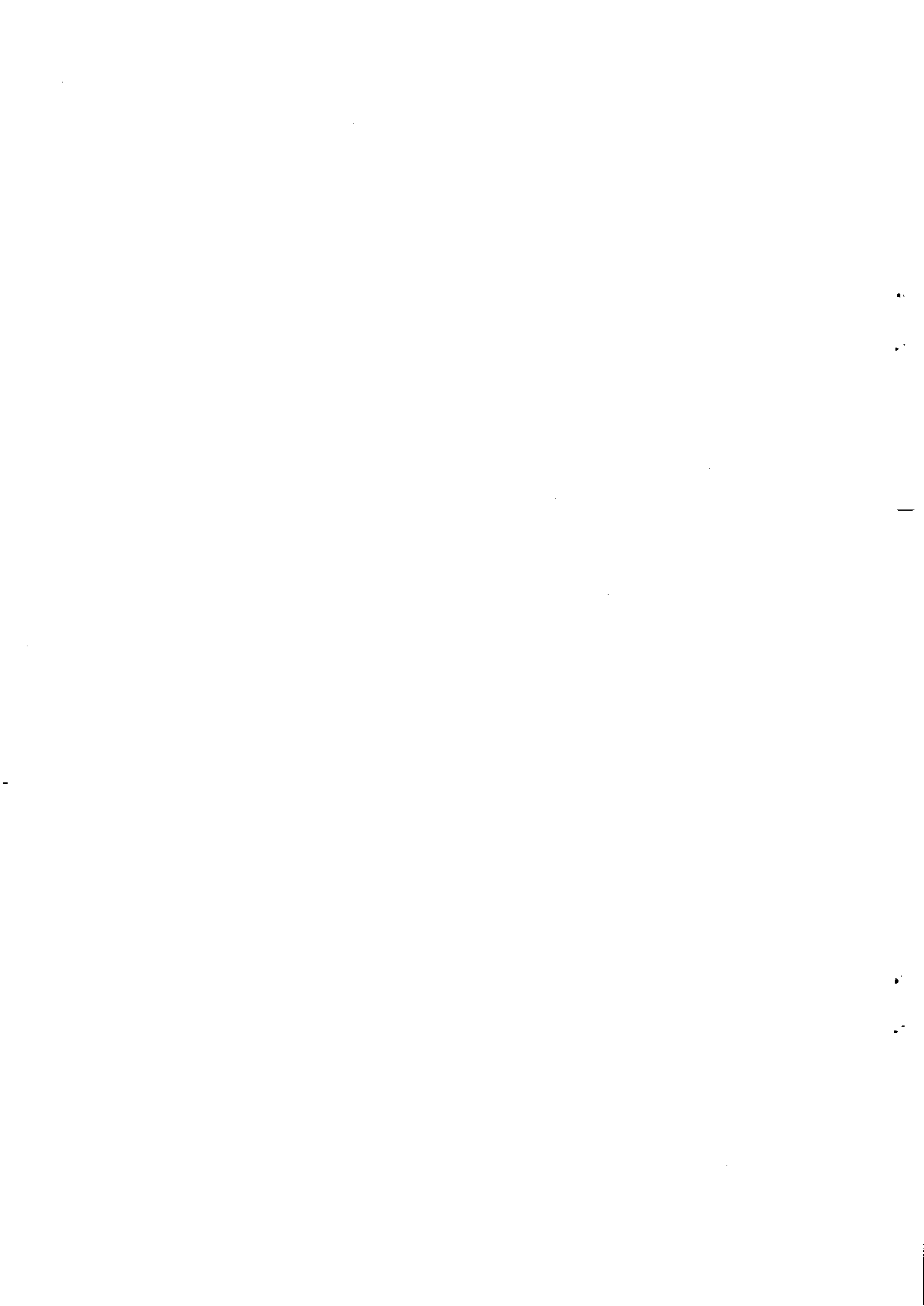

SECTION 8 TAPE RUN ALIGNMENT

8-1. T CORRECTION GUIDE SLANTNESS ADJUSTMENT

Tool: Dental mirror

Check procedure:

- (1) Insert a KCA-60 cassette tape and put the unit into the Threading mode. Just as the Pinch Roller passes in front of the T Correction Guide, quickly turn the power OFF.
- (2) Check that the clearance between the upper bracket of the T Correction Guide and the top edge of the tape meets the required specification.

Adjustment procedure:

- (1) Loosen the fixing screw of the T Correction Guide 1/4 to 1/2 turn.
- (2) Adjust the position of the T Correction Guide with a flatblade screwdriver (3 mm dia.) to meet the required specification.
- (3) After adjustment, perform Section 8-2, Play Mode Tape Path Adjustment (1).

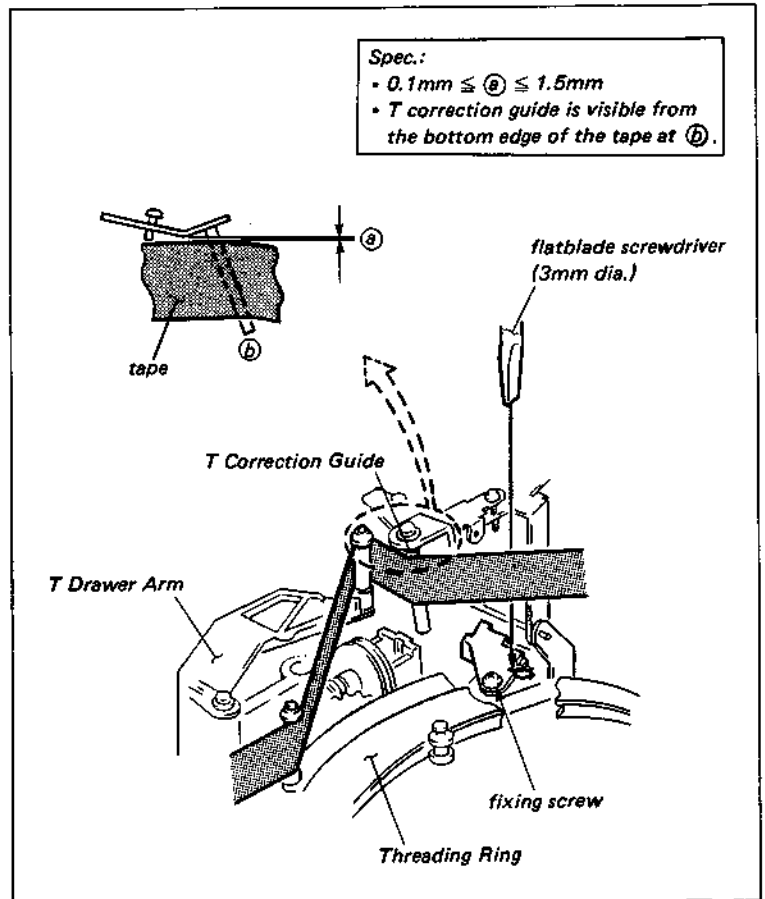

8-2. PLAY MODE TAPE PATH ADJUSTMENT (1)

. It is required that Section 8-1, T Correction Guide Slantness Adjustment and Section 8-4, FF/FWD Mode Tape Path Adjustment are correct before initiating this adjustment.

Mode: PLAY mode with a cassette tape

Check procedure:

- (1) Insert a KCA-60 cassette tape which has been advanced about half way through (30 minutes). Put the unit into the PLAY mode.
- (2) Check that the tape runs without any curling at the upper or lower flange of the T Drawer Guide. (Spec. (1))
- (3) Check that tape tension is equal at the top and bottom of the tape around the T Drawer Guide, and that the tape runs without any curling at the lower flange of the T Drawer Guide. (Spec.(2))

Adjustment procedure:

For Spec.1

- (1) Adjust the height of the T Drawer Arm by turning the T Drawer Arm Height Adjustment Screw.

For Spec.2

- (2) Bend the T Correction Guide in the direction of the arrow. Turn the adjustment screw if necessary to meet the required specification.

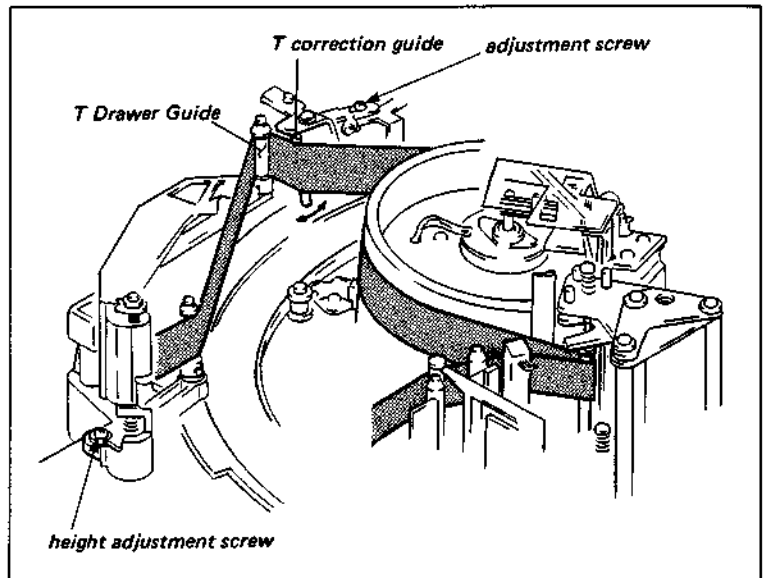

8-3. PLAY MODE TAPE PATH ADJUSTMENT (2)

Tool: Dental mirror

Hexagonal screwdriver

(across flat has 0.89mm)

Mode: PLAY mode with a cassette tape

Check procedure:

- (1) Open the RP-30A Board after removing the two fixing screws.
- (2) Insert a KCA-60 cassette tape which has been advanced about half way through (30 minutes). Put the unit into the PLAY mode.
- (3) At the * marks (two positions) in the figure, check that tape tension is equal at the top and bottom of the tape. (Spec.(1))
- (4) Check that the clearance between the lower flange of the Threading Roller and the bottom edge of the tape meets the required specification (2).

Adjustment procedure:

- (1) Loosen the set screw at the top of the Threading Roller 1/2 to 1 turn.

For Spec.1

- (2) Adjust the slantness of the Threading Roller by turning the slantness adjustment screw.

NOTE:

- (i) After adjustment, perform Section 8-4, FF/REW Mode Tape Path Adjustment.

For Spec.2

- (3) Adjust the height of the Threading Roller by turning the upper flange of the Threading Roller.
- (4) Check that the slantness and the height meet the required specifications (1) and (2).
- (5) After adjustment, tighten the set screw and perform the check procedure.

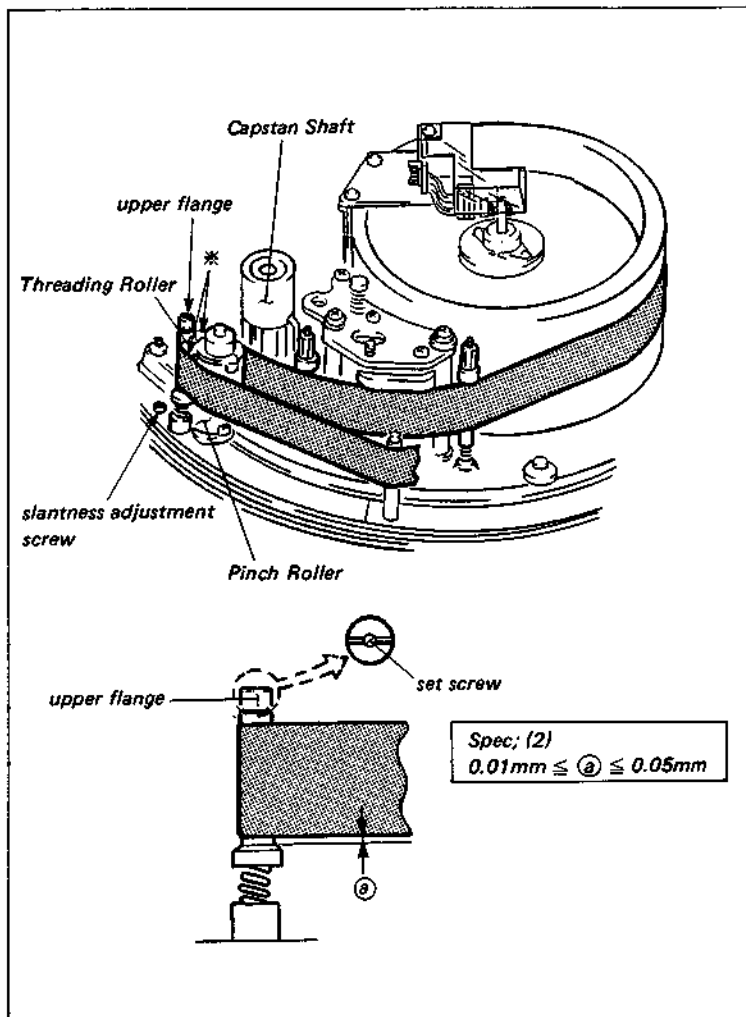

8-4. FF/REW MODE TAPE PATH ADJUSTMENT

Tool: Dental mirror

Mode: FF/REW mode with a cassette tape

Check procedure:

- (1) Open the RP-30A Board after removing the two fixing screws.
- (2) Insert a KCA-60 cassette tape which has been advanced about half way through (30 minutes).
- (3) Put the unit into the REW mode. Check that the tape contacts the lower flange of the Threading Roller without any curling. Check that tape tension is equal between the Capstan Shaft and TG-4.
- (4) Put the unit into the FF mode. Check that the clearance between the lower flange of the Threading Roller and the bottom edge of the tape meets the required specification and that the tape does not curl at the lower or upper flange of TG-4.

Adjustment procedure:

- (1) Loosen the set screw at the top of the Threading Roller 1/2 to 1 turn.

For Spec.1

- (2) If the tape does not contact the flange "a" of the Threading Guide, turn the slantness adjustment screw in the clockwise direction until the tape contacts the flange.
- (3) If tape tension is not equal between the Capstan Shaft and TG-4, turn the upper flange of the Threading Roller until tape tension is equal.

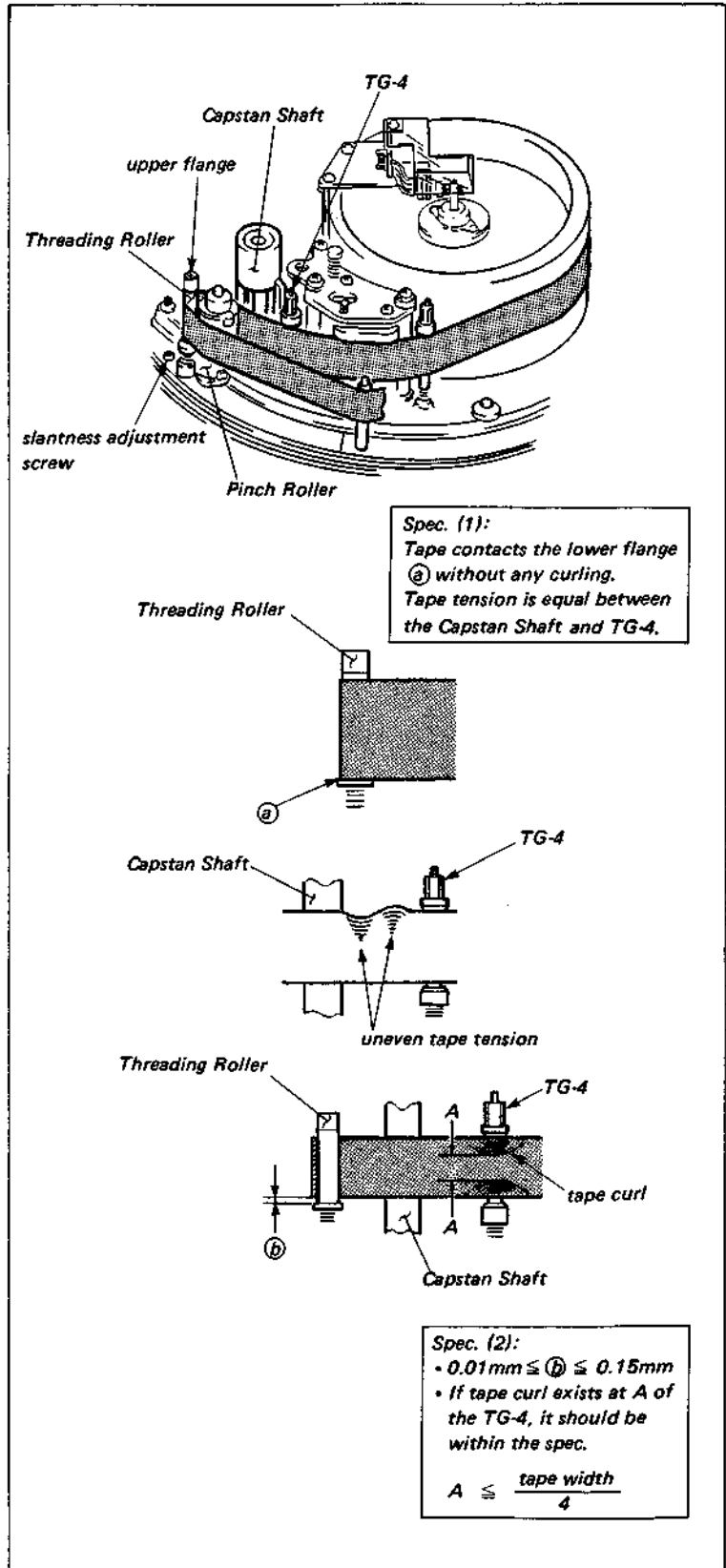

For Spec.2

- (4) When there is no clearance at the Threading Roller "b", turn the upper flange of the Threading Roller to meet the required specification. (If spec.(2) is contradictory to spec.(1), then spec.(1) has priority over spec.(2).)
- (5) If the tape curls at the upper flange of the Threading Roller, note clearance "b" at the Threading Roller. When there is clearance at "b", put the unit into the PLAY mode. Note that the tape curls at TG-4.
- (6) If the tape curls at TG-4 in the PLAY mode, perform Section 8-9, Tracking Adjustment.
- (7) If the tape runs without any curling in the PLAY mode, replace the Pinch Roller Block with a new one.
- (8) After adjustment, perform Section 8-3, PLAY Mode Tape Pass Adjustment (2).

8-5. FWD X 5 / REV X 5 SERCH MODE TAPE PATH ADJUSTMENT

Check procedure:

- (1) Open the RP-30A Board after removing the two fixing screws.
- (2) Insert a KCA-60 cassette tape which has been advanced about half way through (30 minutes).
- (3) When the unit is switches directly from the REV X 5 mode to the FWD X 5 mode (or the reverse), check that tape tension is equal between the Capstan Shaft and TG-4. If tape tension is not equal, check that the wrinkle disappears within 2 seconds.

Adjustment procedure:

- (1) Perform Section 8-3, PLAY Mode Tape Pass Adjustment (2) and Section 8-4, FF / REW Mode Tape Pass Adjustment to meet the required specification.

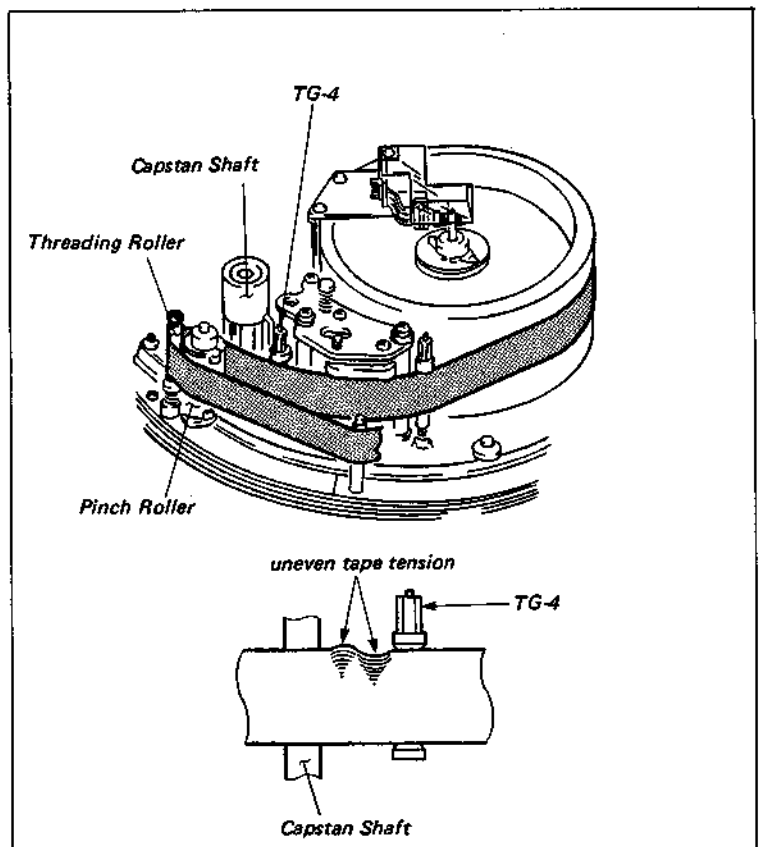

8-8. TIME CODE HEAD ADJUSTMENT

- The Time Code Head is located near the drum. During adjustment of the Time Code Head, be sure to not damage the video head or scratch the drum.
- The Time Code Head Zenith Adjustment is closely related to the Azimuth Adjustment and the Height Adjustment. When performing any of these adjustments, always perform the other two adjustments at the same time.

8-8-1. Time Code Head Zenith Adjustment

Tool: Flatness plate

Mode: EJECT completion mode

Check procedure:

- (1) Place the Flatness Plate against the Entrance Roller and the Time Code Head. Check that the clearance between the Entrance Roller and the Flatness Plate meets the required specification.

Adjustment procedure:

- (1) Loosen the fixing screw 1/4 to 1/2 turn.
- (2) Adjust the zenith of the Time Code Head by turning the zenith adjustment screw to meet the required specification.
- (3) Tighten the fixing screw and perform the check procedure.
- (4) After adjustment, perform the Time Code Head Azimuth Adjustment and the Height Adjustment.

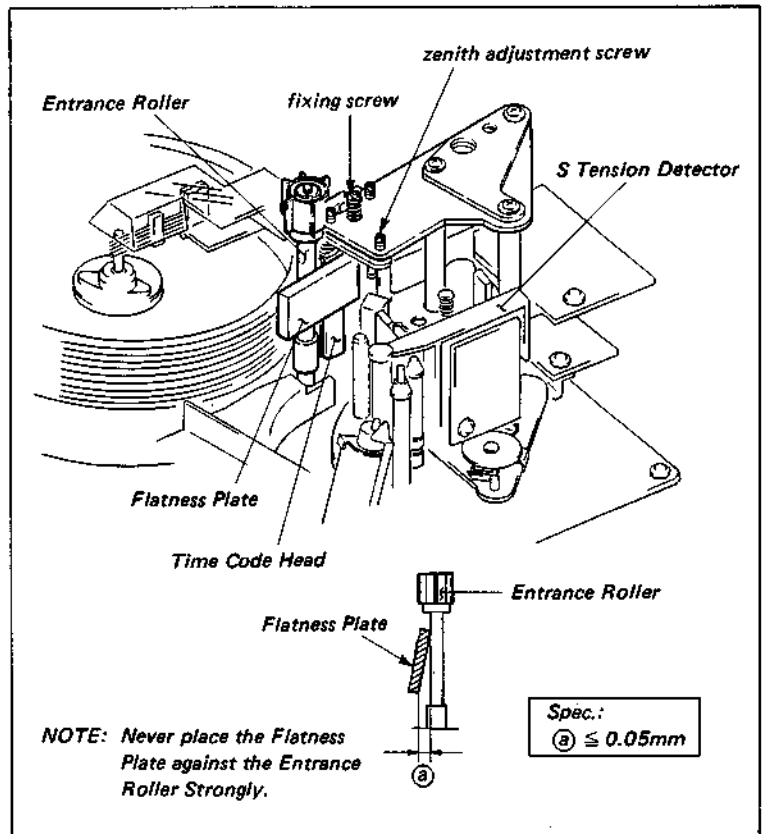

8-8-2. Time Code Head Azimuth Adjustment

Mode: EJECT completion mode

Check procedure:

- (1) Check that the clearance between the top or the bottom of the Time Code Head and the Entrance Roller is parallel.

Adjustment procedure:

- (1) Loosen the fixing screw 1/4 to 1/2 turn.
- (2) Adjust the azimuth of the Time Code Head by turning the azimuth adjustment screw to meet the required specification.
- (3) Tighten the fixing screw and perform the check procedure.
- (4) After adjustment, perform the Time Code Head Zenith Adjustment and the Height Adjustment.

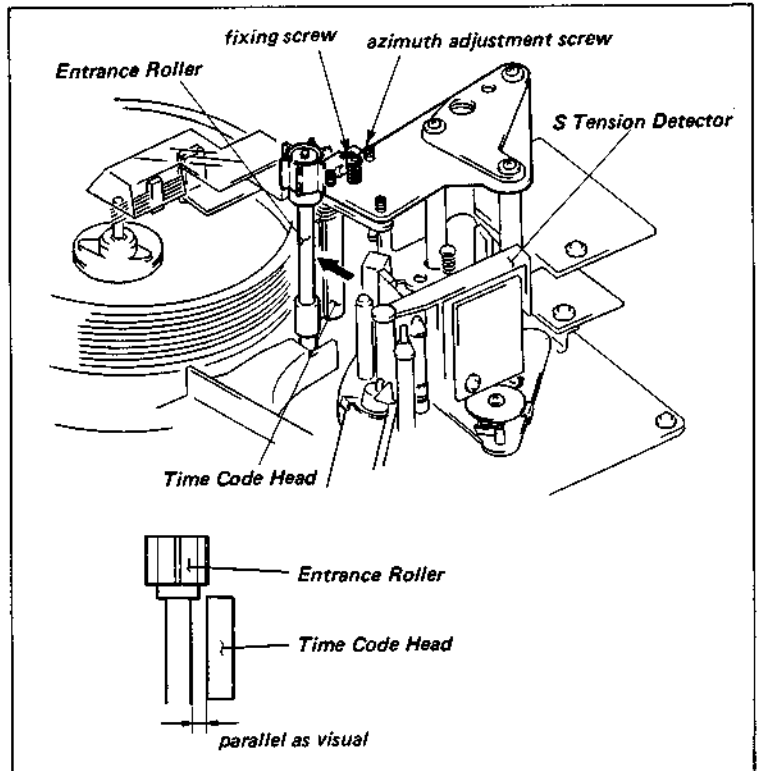

8-8-3. Time Code Head Head-to-tape Contact Adjustment

Tool: Alignment tape, RR5-1SD PAL
Oscilloscope

Preparation:

- (1) Connect the oscilloscope to TP102 on the BC-11 Board.
- (2) Playback the time code signal portion of the alignment tape.

Adjustment procedure:

- (1) Loosen the fixing screw of the head-to-tape contact adjustment 1/4 to 1/2 turn.
- (2) Insert a flatblade screwdriver (3mm dia.) into the notch as shown in the figure. Find the two points where the output waveform is at maximum and just starts to decrease.
- (3) Adjust the position of the Time Code Head Block with a flatblade screwdriver (3 mm dia.) to the center of these two points. After adjustment, tighten the fixing screw.

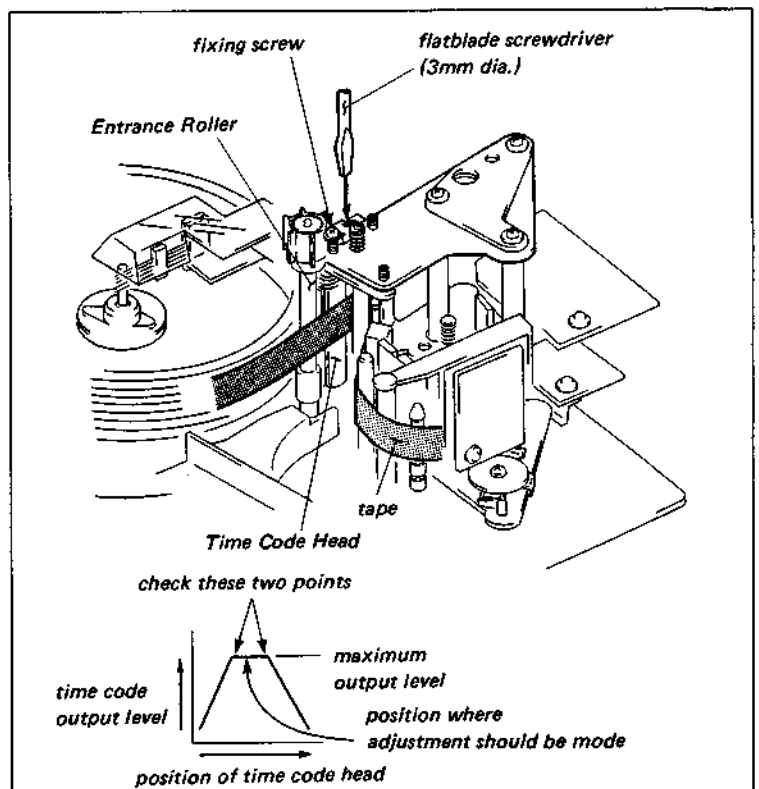

8-9. TRACKING ADJUSTMENT

The Tracking Adjustment is required to be performed in the following order:

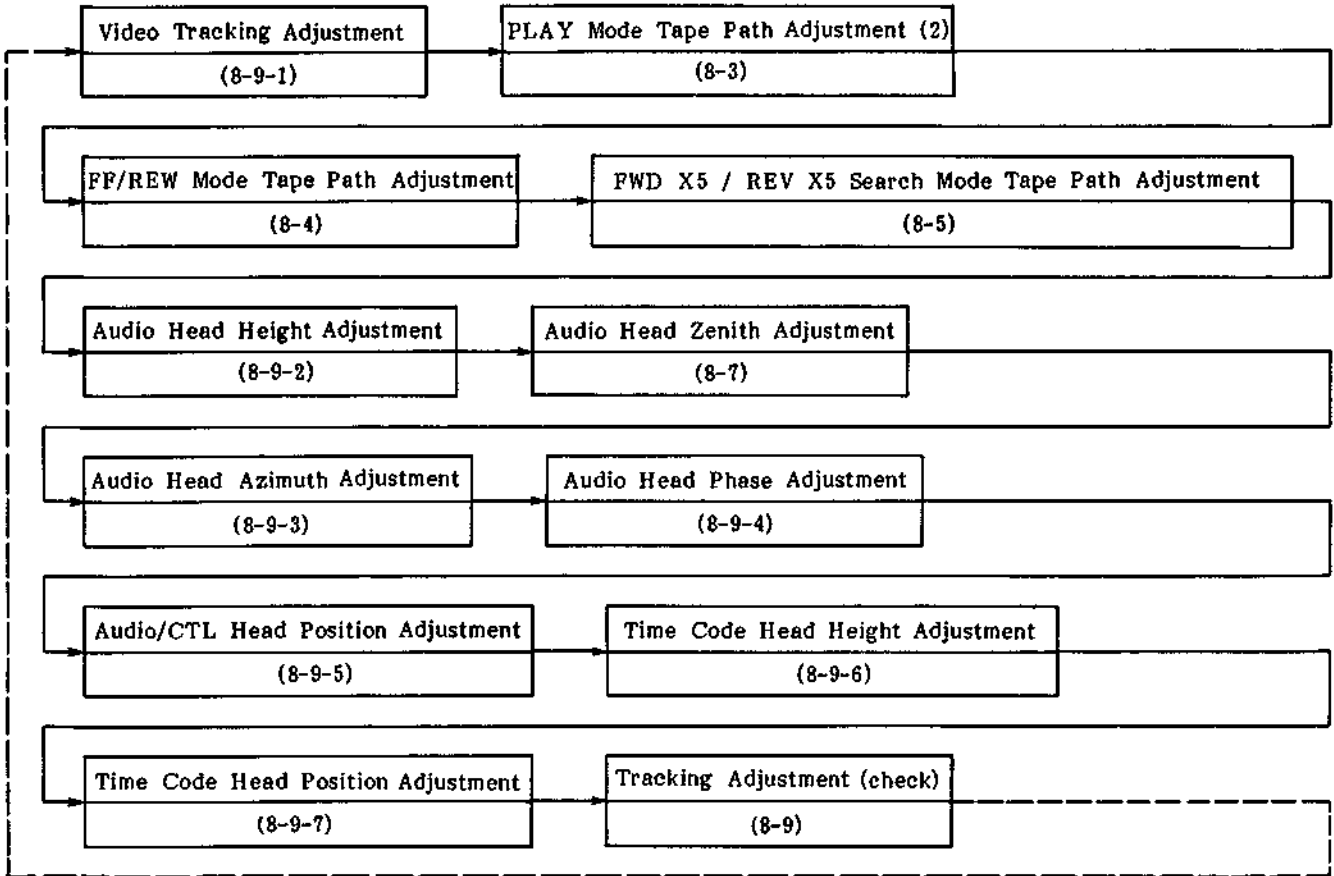

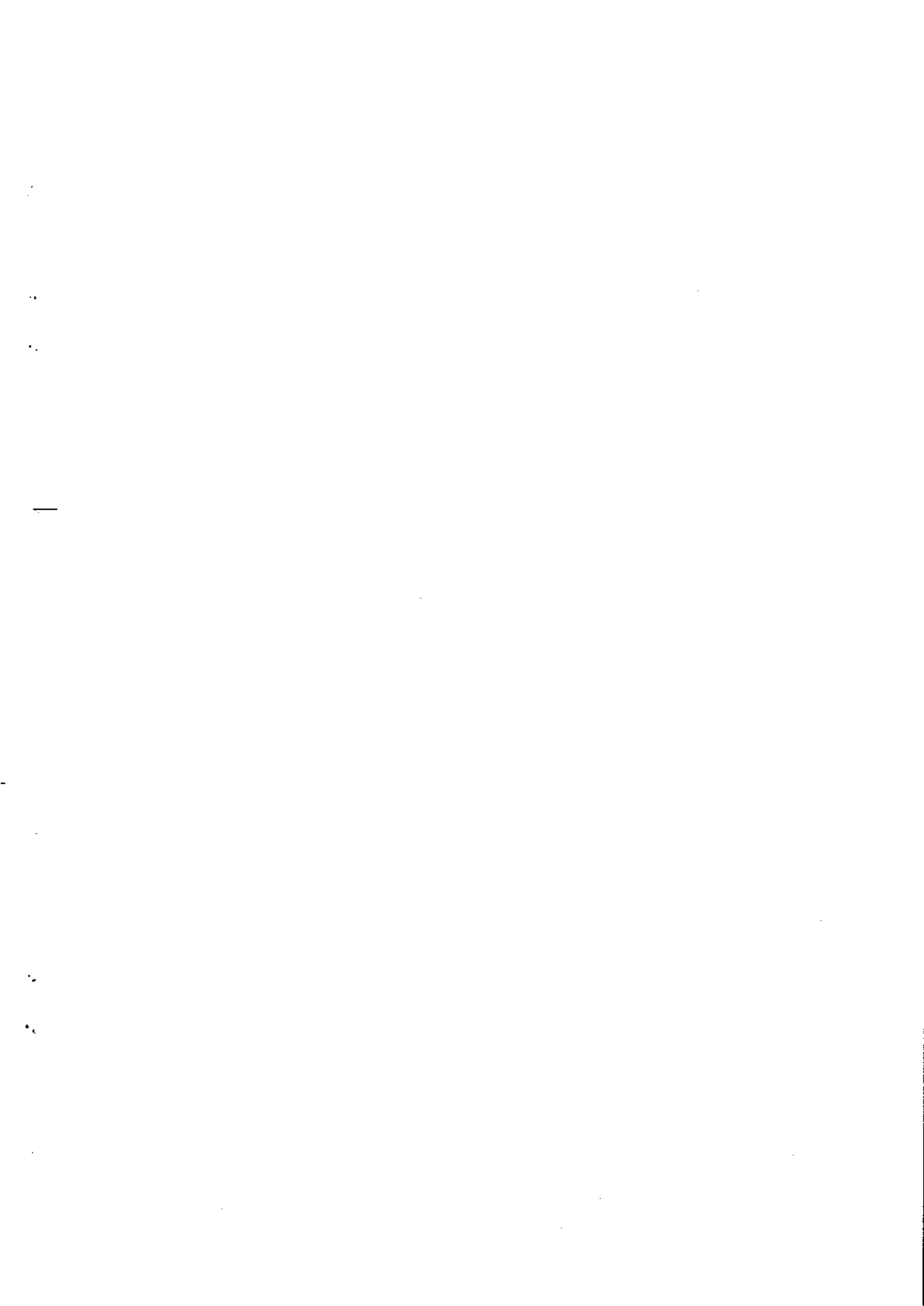

S/N UP TO 13730

8-9-1. Video Tracking Adjustment

Tool: Alignment tape, RR2-1SD PAL
Flatness plate
Dental mirror
Extension board (EX-128)
Oscilloscope

Preparation:

- (1) Set the Bit 8 of S201 on the SV-88A Board to ON and check that the Bit 7 is set to OFF. Check that the S202 is set to OFF.
- (2) Extend the DM-55 Board with the extension board.
- (3) Connect the oscilloscope to TP18 on the DM-55 Board and EXT.TRIG to TP4 on the DM-55 Board.
- (4) Playback the alignment tape.

Check procedure:

- (1) While turning the TRACKING control knob, check that the RF waveform maintains a flat envelope while the amplitude increases and decreases.
- (2) Check that fluctuation and head-to-tape contact of the RF envelope are within the specification at the center detent position of the TRACKING control knob.
- (3) After check, if meets the required specification, reset the S201 and S202 on the SV-88A Board.

Adjustment procedure:

The S Drawer Roller Block has three adjustment screws. These three adjustment screws function as follows:

(i) Slantness adjustment screw (a)

Turn this screw in the clockwise direction, and the S Drawer Roller slants in the direction of arrow A.

(ii) Slantness adjustment screw (b)

Turn this screw in the counterclockwise direction, and the S Drawer Roller slants in the direction of arrow B. This screw is used for removing tape curl at the upper flange of the S Drawer Roller. However, this screw is used only when the tape curls at the flange of the S Drawer

Spec.: Turn the SKEW
Volume to center
click.

$$\frac{A}{B} \geq 0.80 \quad \frac{D}{B} \geq 0.80$$

(fluctuation)

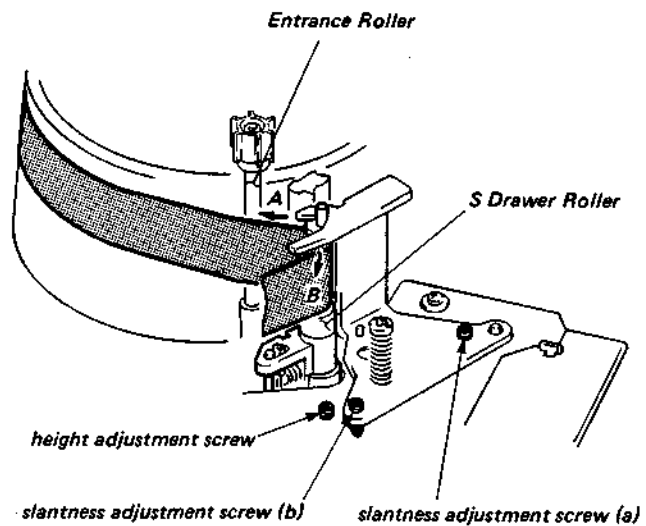
$$\frac{C}{B} \geq 0.90$$

S/N 13731 AND HIGHER

8-9-1. Video Tracking Adjustment

Tool: Alignment tape, RR2-1SD PAL
Flatness plate
Dental mirror
Extension board (EX-128)
Oscilloscope

Preparation:

- (1) Set the Bit 8 of S101 on the SV-113 Board to ON. Check that the S301 is set to OFF.
- (2) Extend the DM-55 Board with the extension board.
- (3) Connect the oscilloscope to TP18 on the DM-55 Board and EXT.TRIG to TP4 on the DM-55 Board.
- (4) Playback the alignment tape.

Check procedure:

- (1) While turning the TRACKING control knob, check that the RF waveform maintains a flat envelope while the amplitude increases and decreases.
- (2) Check that fluctuation and head-to-tape contact of the RF envelope are within the specification at the center detent position of the TRACKING control knob.
- (3) After check, if meets the required specification, reset the S101 and S301 on the SV-113 Board.

Adjustment procedure:

The S Drawer Roller Block has three adjustment screws. These three adjustment screws function as follows:

- (i) Slantness adjustment screw (a)
Turn this screw in the clockwise direction, and the S Drawer Roller slants in the direction of arrow A.
- (ii) Slantness adjustment screw (b)
Turn this screw in the counterclockwise direction, and the S Drawer Roller slants in the direction of arrow B. This screw is used for removing tape curl at the upper flange of the S Drawer Roller. However, this screw is used only when the tape curls at the flange of the S Drawer

Spec.: Turn the SKEW
Volume to center
click.

$$\frac{A}{B} \geq 0.80 \quad \frac{D}{B} \geq 0.80$$

(fluctuation)

$$\frac{C}{B} \geq 0.90$$

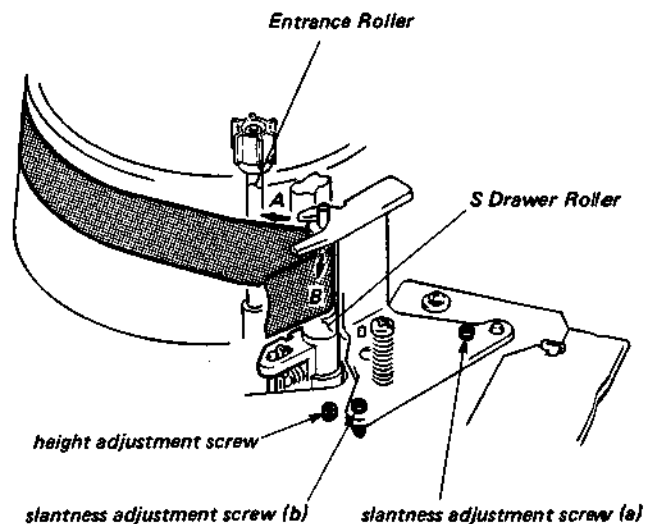

Roller, even though the RF output waveform meets the required specification.

(iii) Height adjustment screw

Turn this screw in the clockwise direction, and the height of the S Drawer Roller lowers.

- . When tape guides (TG-3, TG-4) are adjusted, loosen the locking screw about 1 turn and adjust the height by turning the height adjustment nut.

. When tracking at the entrance side of the drum is not good.

- (1) Turn the TRACKING control knob until the RF envelope amplitude is 70 to 80 % of maximum.
- (2) Adjust the height and the slantness of the S Drawer Roller by turning the height adjustment screw and the slantness adjustment screw (a) until the RF envelope of the entrance side is flat.

NOTE:

- (i) Check the surface of the running tape very carefully around the S Drawer Roller. Check that tape tension is equal at the top and bottom of the tape.
 - (ii) Check that the tape runs in contact with the upper flange of the S Drawer Roller without any curling.
- . When tracking at the center of the drum is not good.
(It is required that the Tracking adjustment at the entrance side of the drum is correct before initiating this adjustment.)
- (3) Turn the TRACKING control knob until the RF envelope amplitude is 70 to 80% of maximum.
 - (4) Adjust the height and the slantness of the S Drawer Roller by turning the height adjustment screw and the slantness adjustment screw (a) until the RF envelope at the center of the drum is flat.

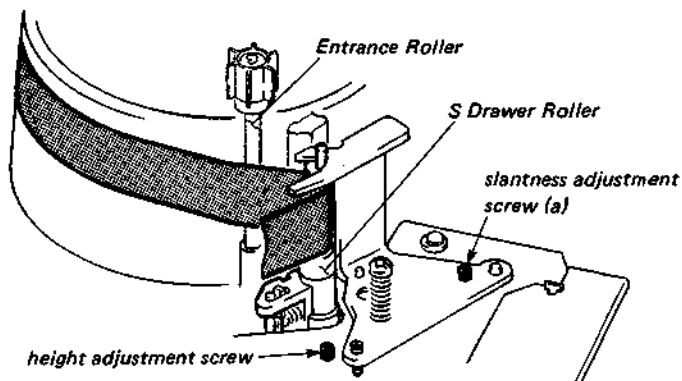
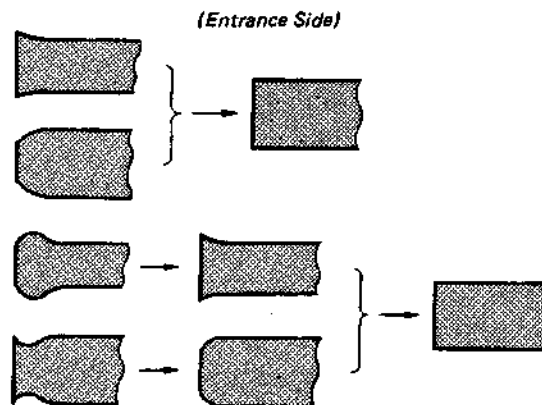
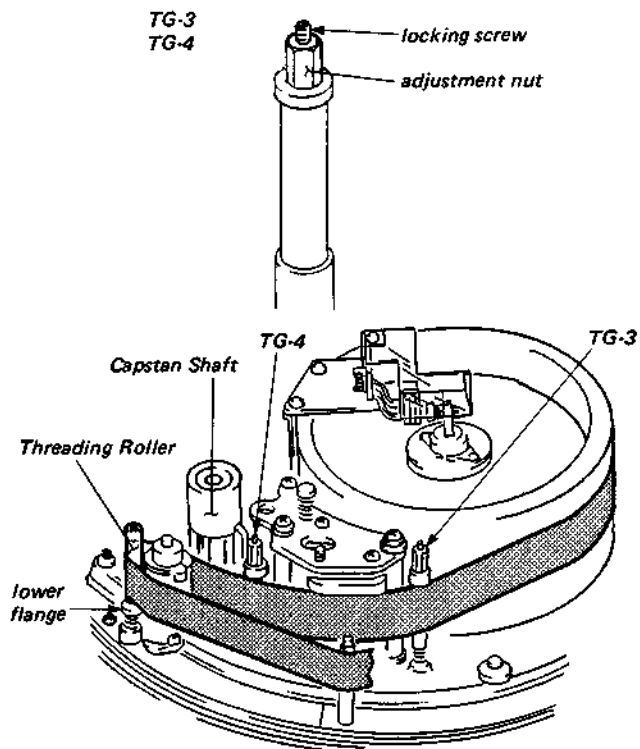

NOTE:

- (i) Adjust the slantness adjustment screw (a) in the clockwise direction within a 10 degree angle.
 - (ii) When the tracking of the center of the drum is adjusted, the RF envelope at the entrance side of the drum should remain flat.
 - (iii) Check that the tape runs in contact with the upper flange of the S Drawer Roller without any curling.
- (5) If the RF envelope is not flat in Step (4), adjust the height of TG-3 and TG-4.
- (6) If the RF envelope is not flat in Steps (4) and (5), adjust the zenith of the Audio/CTL Head within the allowable range. Adjust the height of TG-3 and TG-4 again.
- (7) Check that the clearance between the bottom edge of the tape and the lower flange of the Threading Roller is 0.01 mm to 0.05 mm. If it is out of the specification, adjust the height of the Threading Roller by turning the upper flange of the Threading Roller.
- . When tracking at the exit side of the drum is not good.
- (8) Turn the TRACKING control knob until the RF envelope amplitude is 70 to 80% of maximum.
- (9) If the RF envelope is not flat as shown in the figure 1, adjust the height of TG-4 until the RF envelope is flat. After this adjustment, adjust the height of TG-3 so that the tape runs in contact with the upper flange. If the RF envelope is not flat as shown in the figure 2, adjust the height of TG-3 and TG-4 until the RF envelope is flat. If it is not, adjust the zenith of the Audio/CTL Head within the allowable range. Adjust the height of TG-3 and TG-4 again.

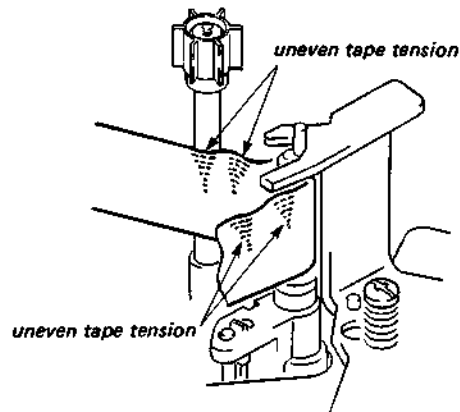

(Audio/CTL Head Zenith Adjustment)

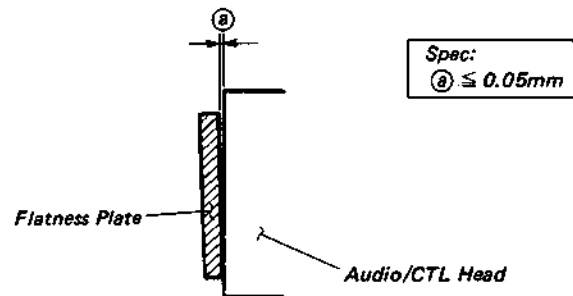

(Exit Side)

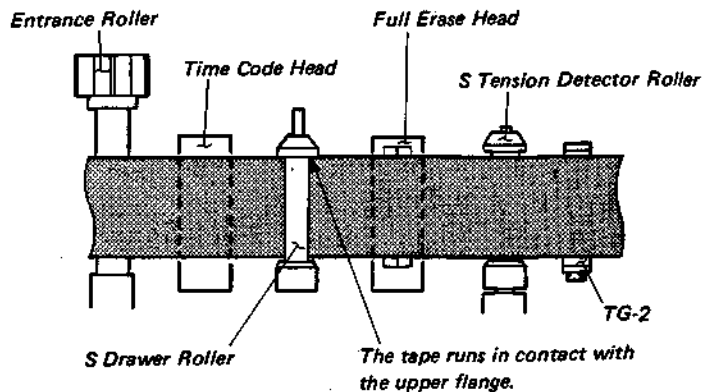
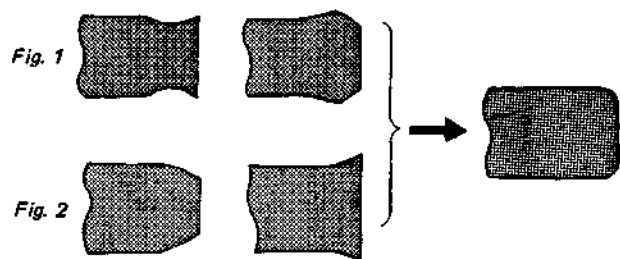

S/N UP TO 13730

- (10) Check that the clearance between the bottom edge of the tape and the lower flange of the Threading Roller is 0.01 mm to 0.05 mm. If it is out of the specification, adjust the height of the Threading Roller by turning the upper flange of the Threading Roller.
- (11) After adjustment, if meets the required specification, reset S201 and S202 on the SV-88A Board.

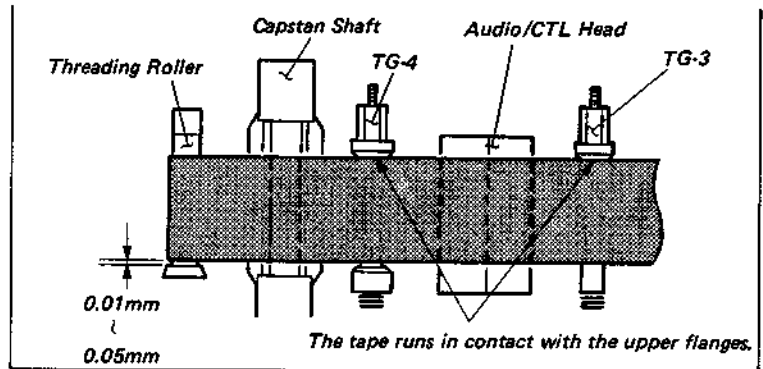

8-9-2. Audio Head Height Adjustment

Tool: Alignment tape, RR5-1SD PAL
VTVM or oscilloscope

Preparation:

- (1) Connect the VTVM or oscilloscope to the AUDIO OUT CH-1 and CH-2 connectors of the connector panel.
- (2) Playback the audio 1 kHz signal portion of the alignment tape.

Check procedure:

- (1) Check that the CH-1 output level increase is less than 0.5 dB when pressing down at A. If it is out of the specification, perform adjustment procedures (1) and (2).
- (2) Check that the CH-2 output level increase is less than 0.5 dB when pushing up at B. If it is out of the specification, perform adjustment procedures (3) and (4).

Adjustment procedure:

- (1) Loosen the locking screw and turn adjustment screws (R) and (A) an equal amount in the counterclockwise direction. Turn adjustment screw (C) the same amount in the clockwise direction.
- (2) Tighten the locking screw and check the height of the Audio Head again.
- (3) Loosen the locking screw and turn adjustment screws (R) and (A) an equal amount in the clockwise direction. Turn the adjustment screw (C) the same amount in the counterclockwise direction.
- (4) Tighten the locking screw and check the height of the Audio Head as described in the check procedure.

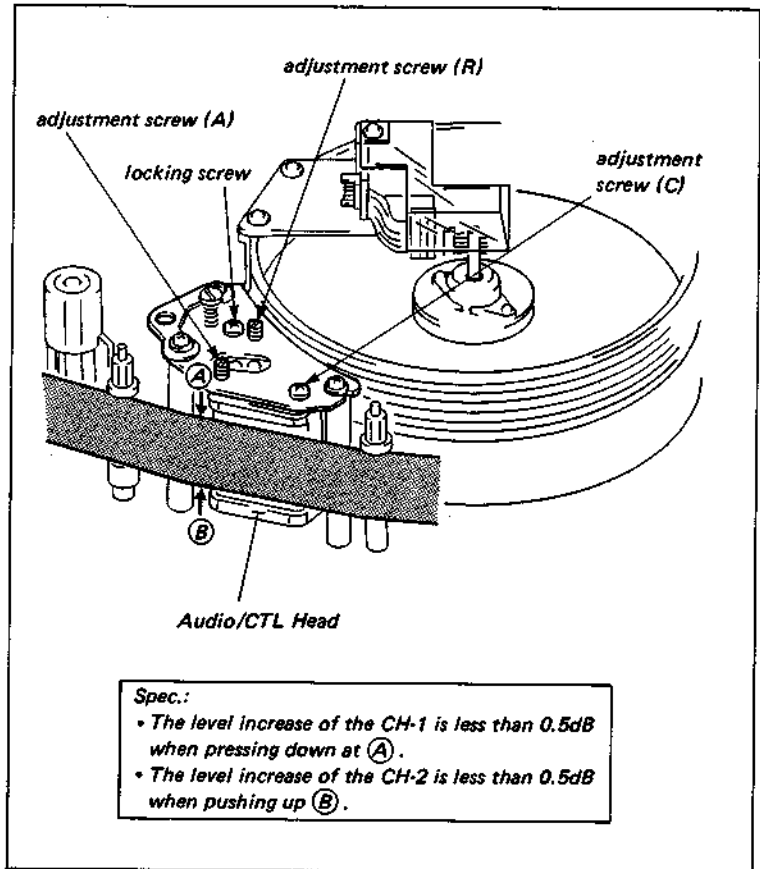

S/N 13731 AND HIGHER

- (10) Check that the clearance between the bottom edge of the tape and the lower flange of the Threading Roller is 0.01 mm to 0.05 mm. If it is out of the specification, adjust the height of the Threading Roller by turning the upper flange of the Threading Roller.
- (11) After adjustment, if it meets the required specification, reset S101 and S301 on the SV-113 Board.

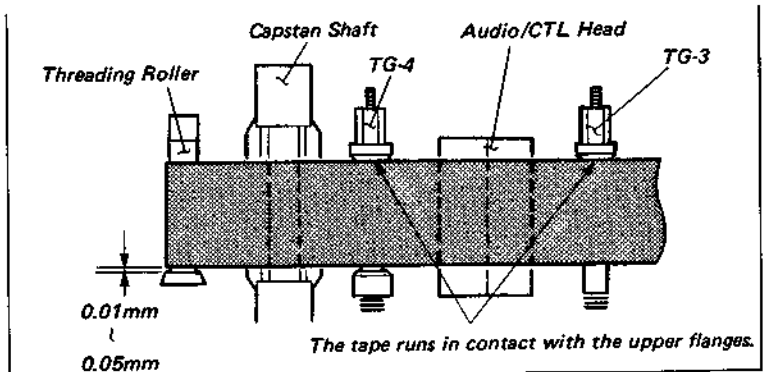

8-9-2. Audio Head Height Adjustment

Tool: Alignment tape, RR5-1SD PAL
VTVM or oscilloscope

Preparation:

- (1) Connect the VTVM or oscilloscope to the AUDIO OUT CH-1 and CH-2 connectors of the connector panel.
- (2) Playback the audio 1 kHz signal portion of the alignment tape.

Check procedure:

- (1) Check that the CH-1 output level increase is less than 0.5 dB when pressing down at A. If it is out of the specification, perform adjustment procedures (1) and (2).
- (2) Check that the CH-2 output level increase is less than 0.5 dB when pushing up at B. If it is out of the specification, perform adjustment procedures (3) and (4).

Adjustment procedure:

- (1) Loosen the locking screw and turn adjustment screws (R) and (A) an equal amount in the counterclockwise direction. Turn adjustment screw (C) the same amount in the clockwise direction.
- (2) Tighten the locking screw and check the height of the Audio Head again.
- (3) Loosen the locking screw and turn adjustment screws (R) and (A) an equal amount in the clockwise direction. Turn the adjustment screw (C) the same amount in the counterclockwise direction.
- (4) Tighten the locking screw and check the height of the Audio Head as described in the check procedure.

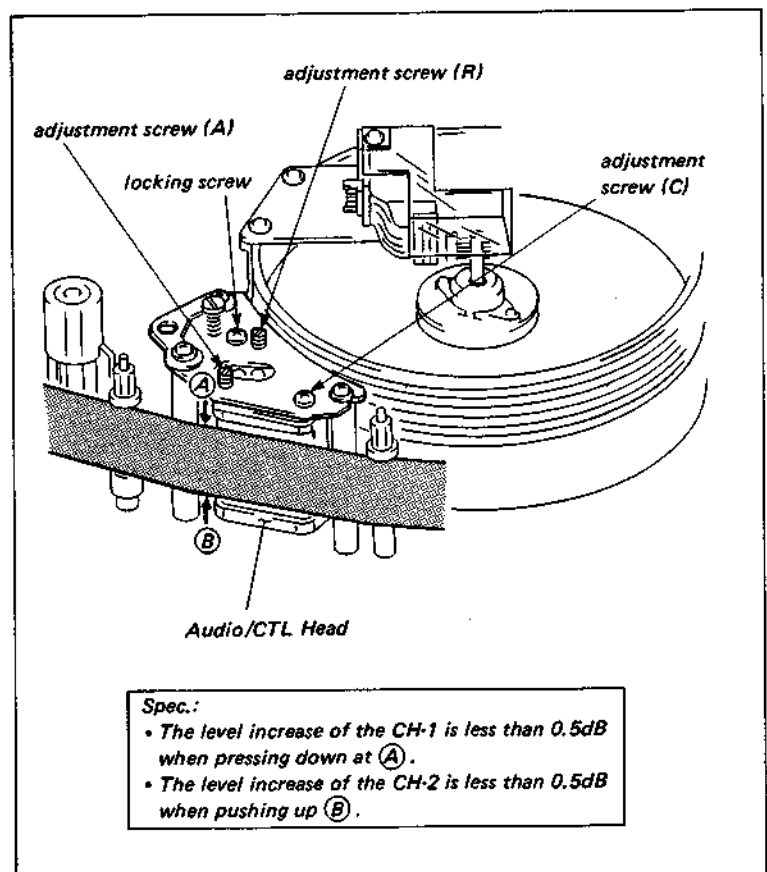

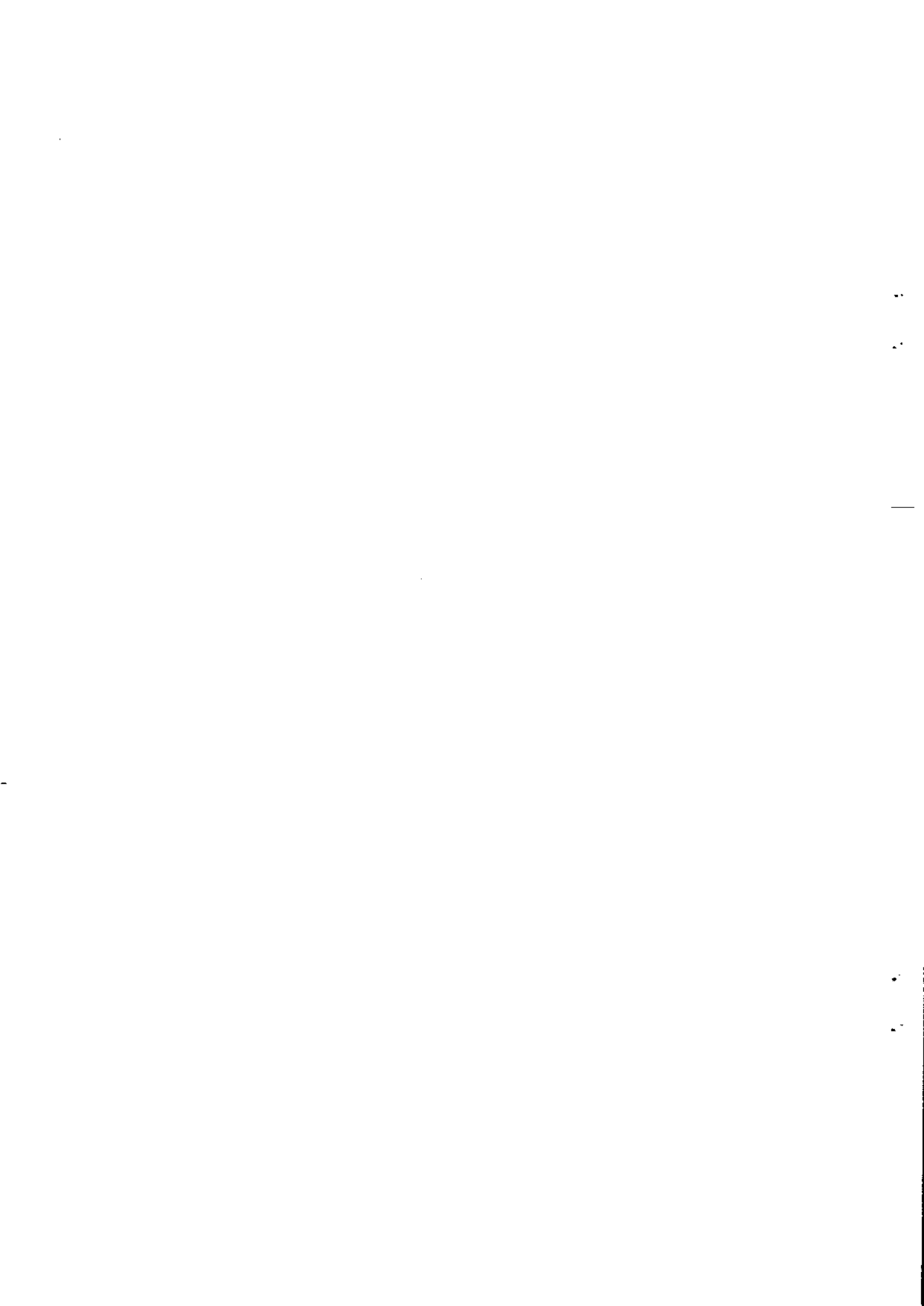

8-9-3. Audio Head Azimuth Adjustment

Tool: Alignment tape, RR5-1SD PAL
VTVM or oscilloscope

Preparation:

- (1) Connect the VTVM or oscilloscope to the AUDIO OUT CH-1 or CH-2 connector of the connector panel.
- (2) Playback the audio 10 kHz signal portion of the alignment tape.

Adjustment procedure:

- (1) Loosen the locking screw and adjust the audio output level to maximum by turning the adjustment screw.
- (2) Tighten the locking screw and perform the check procedure.

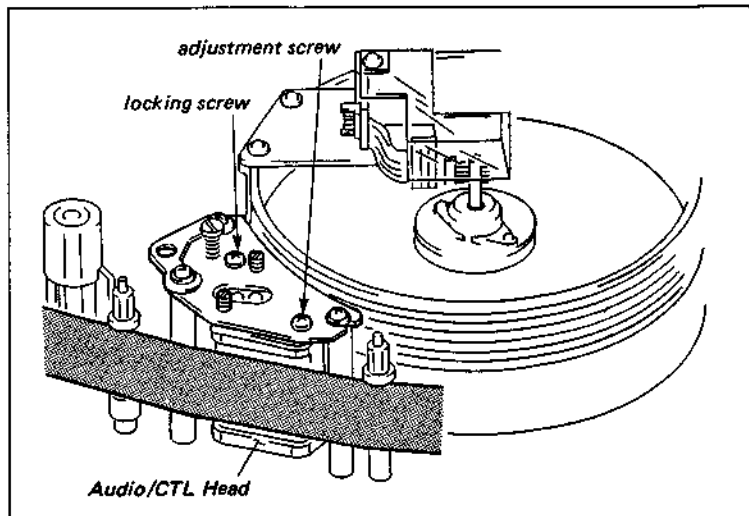

8-9-4. Audio Head Phase Adjustment

Tool: Alignment tape, RR5-1SD PAL
Oscilloscope

Preparation:

- (1) Connect the horizontal and vertical terminals of the oscilloscope to the AUDIO OUT CH-1 and CH-2 connectors of the connector panel.
- (2) Playback the audio 10 kHz signal portion of the alignment tape.
- (3) Adjust the scope for a lissajous waveform with horizontal and vertical amplitudes of 6 cm.

Check procedure:

- (1) Playback the audio 10 kHz signal portion of the alignment tape, and check that the vertical amplitude at the center in the horizontal direction meets the required specification.
- (2) Playback the audio 1 kHz signal portion of the alignment tape, and check that the lissajous waveform meets the required specification.

Adjustment procedure:

- (1) Loosen the locking screw 1/4 to 1/2 turn and adjust the phase by turning the adjustment screw.
- (2) Tighten the locking screw and check the phase again.

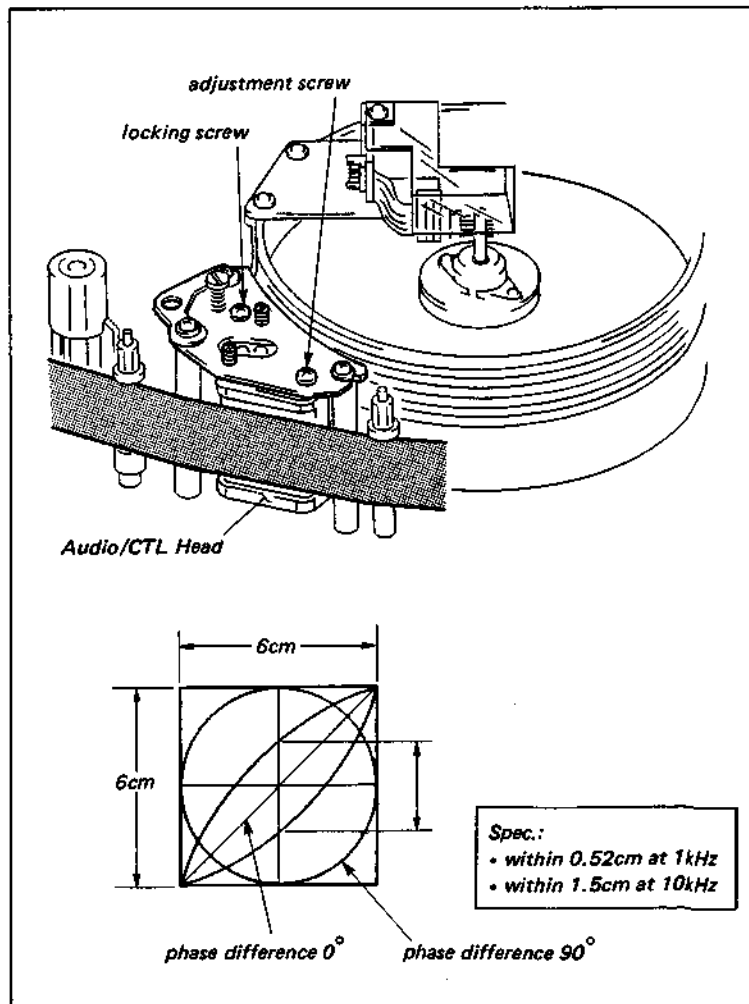

8-9-5. Audio/CTL Head Position Adjustment

Tool: Alignment tape, RR2-1SD PAL
Eccentric screwdriver (5 ϕ)
Extension board (EX-128)
Oscilloscope

Preparation:

- (1) Extend the DM-55 Board with the extension board.
- (2) Connect the oscilloscope to TP18 on the DM-55 Board and the EXT.TRIG to TP4 on the DM-55 Board.
- (3) Playback the alignment tape.

Check procedure:

- (1) While turning the TRACKING control knob, check that the RF envelope has maximum amplitude at the center detent position of the TRACKING control knob.

Adjustment procedure:

- (1) Loosen the three fixing screws 1/4 to 1/2 turn.
- (2) Move the Audio/CTL Head with an eccentric screwdriver (5 ϕ) in the direction of the arrow to meet the required specification.

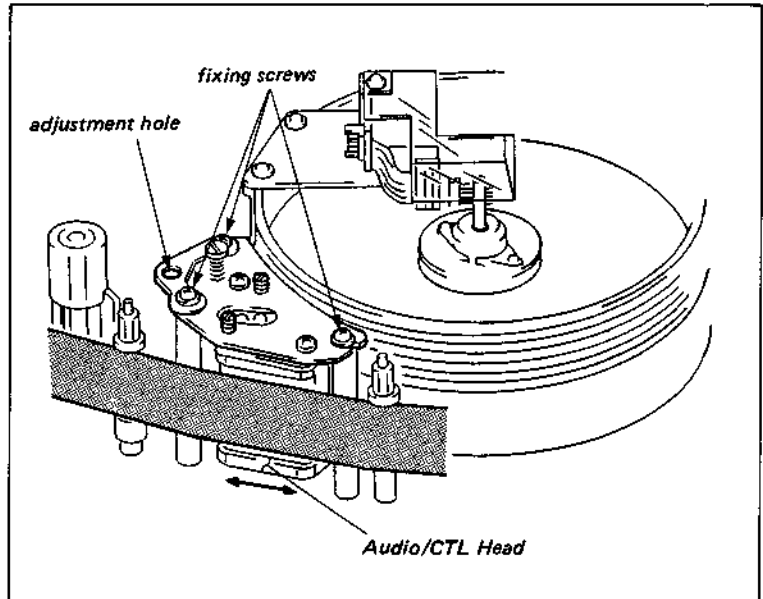

8-9-6. Time Code Head Height Adjustment

Tool: Alignment tape, RR5-1SD PAL
Oscilloscope

Preparation:

- (1) Connect the oscilloscope to TP102 on the BC-11 Board.
- (2) Playback the time code signal portion of the alignment tape.

Check procedure:

- (1) Check that the level increase is less than 0.5 dB when lightly pressing down or pushing up the fixing screw by hand.

Adjustment procedure:

- (1) Loosen the fixing screw 1/4 to 1/2 turn.
• The level increase is more than 0.5 dB when pushing up the fixing screw.
- (2) Turn the three adjustment screws (Height, Azimuth and Zenith) an equal amount in the counterclockwise direction.
• The level increase is more than 0.5 dB when pressing down the fixing screw.
- (3) Turn the three adjustment screws an equal amount in the clockwise direction.
- (4) Tighten the fixing screws and perform the check procedure.
- (5) After adjustment, perform the Time Code Head Zenith Adjustment and Azimuth Adjustment.

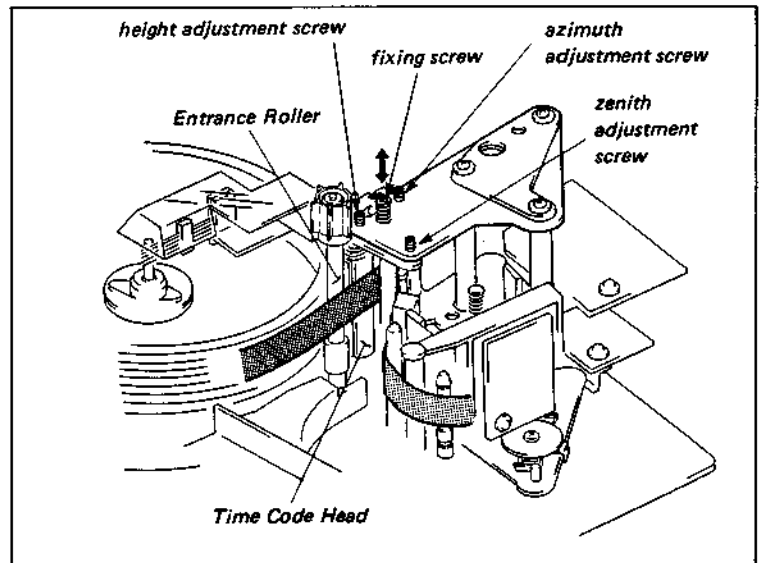

S/N UP TO 13730

8-9-7. Time Code Head Position Adjustment

Tool: Alignment tape, RR5-1SD PAL
Oscilloscope
Eccentric screwdriver (5 ϕ)
Extension board (EX-128, 127)

Preparation:

- (1) Connect the oscilloscope as follows.
CH-1 : TP102 on the BC-11 Board
CH-2 : TP203 / SV-88A
TRIG : TP203 / SV-88A
- (2) Playback the time code signal portion of the alignment tape.

Check procedure:

- (1) Check that the phase relationship between the CTL signal and the Time Code signal meets the required specification.

Adjustment procedure:

- (1) Loosen the three fixing screws of the Time Code Head Block 1/4 to 1/2 turn.
- (2) Adjust the position of the Time Code Head Block with an eccentric screwdriver to meet the required specification.

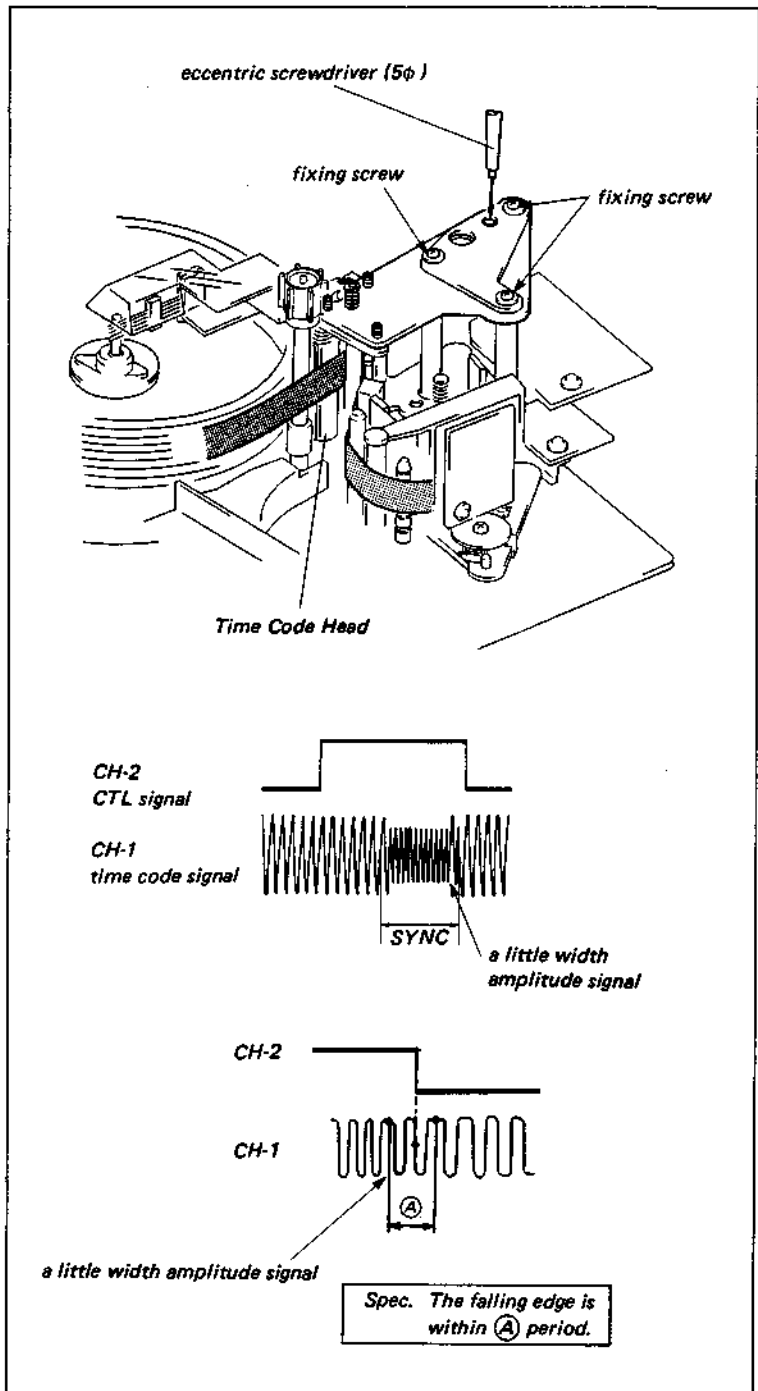

S/N 13731 AND HIGHER

8-9-7. Time Code Head Position Adjustment

Tools: Alignment tape, RR5-1SD PAL
Oscilloscope
Eccentric screwdriver (5 φ)
Extension board (EX-128, 127)

Preparation:

- (1) Connect the oscilloscope as follows.
CH-1 : TP102 on the BC-11 Board
CH-2 : TP103/SV-113
TRIG : TP103/SV-113
- (2) Playback the time code signal portion of the alignment tape.

Check procedure:

- (1) Check that the phase relationship between the CTL signal and the Time Code signal meets the required specification.

Adjustment procedure:

- (1) Loosen the three fixing screws of the Time Code Head Block 1/4 to 1/2 turn.
- (2) Adjust the position of the Time Code Head Block with an eccentric screwdriver to meet the required specification.

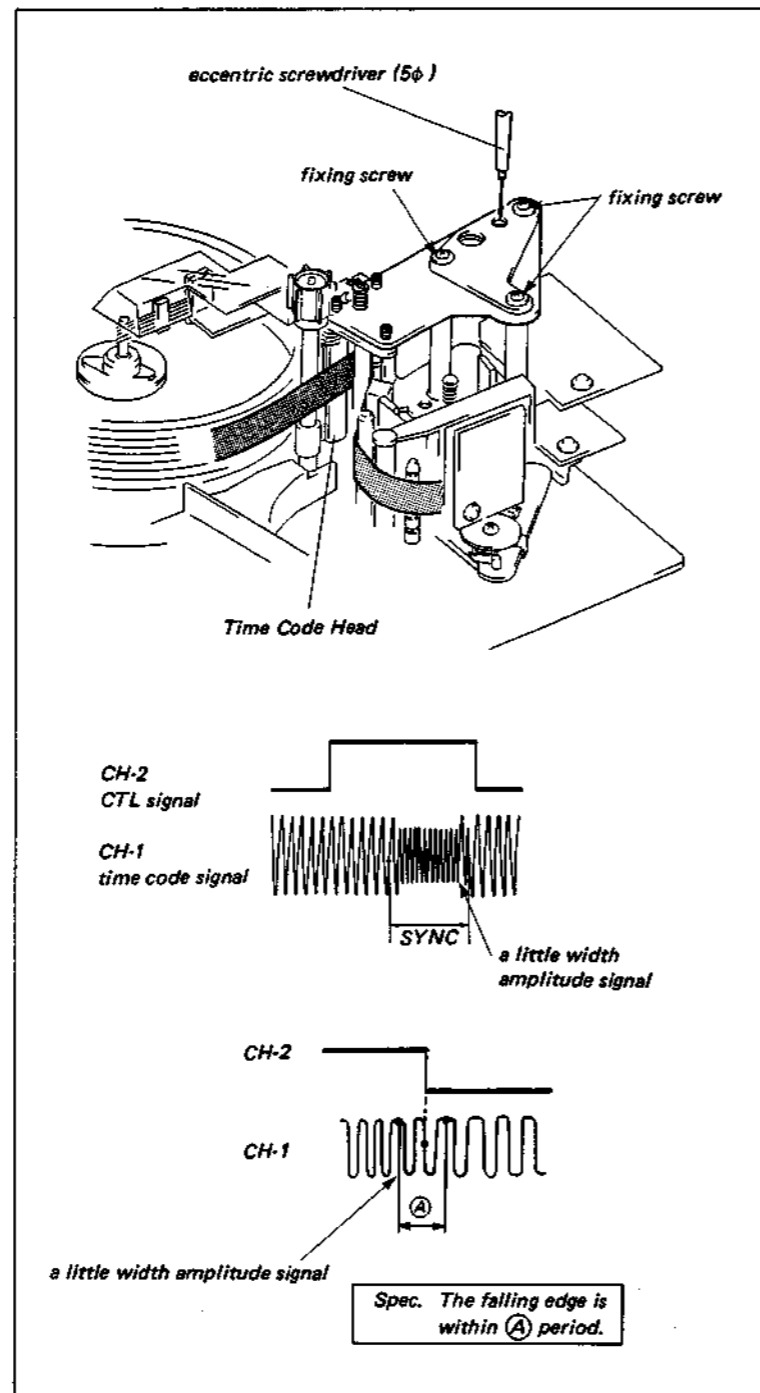

S/N UP TO 13730

8-9-8. Switching Position Adjustment

Tool: Alignment tape, RR5-1SD PAL
Oscilloscope
Extension board (EX-128)

Preparation:

- (1) Connect the oscilloscope as follows:
CH1: TP104/SV-88A
CH2: TP106/SV-88A
EXT.TRIG: TP-106/SV-88A
- (2) Set the Bit 8 of S201 on the SV-88A Board to ON. Check that the Bit 7 of S201 and S202 on the SV-88A Board are set to OFF. (Release the H Lock.)
- (3) Turn the TRACKING volume to FIXED.
- (4) Set the Bit 2 of S201 on the SV-88A Board to ON. Check that the Bit 1 of S201 and S202 on the SV-88A Board are set to OFF. (Mute the phi-square circuit.)
- (5) Playback the color-bar signal portion of the alignment tape.

Check procedure:

- (1) Check that switching pulse waveform meets the required specification.
- (2) If it meets the required specification, reset S201 and S202 on the SV-88A Board.

Adjustment procedure:

- (1) Adjust RV103 and RV104 on the SV-88A Board to meet the required specification.
- (2) After adjustment, reset S201 and S202 on the SV-88A Board to the original positions.

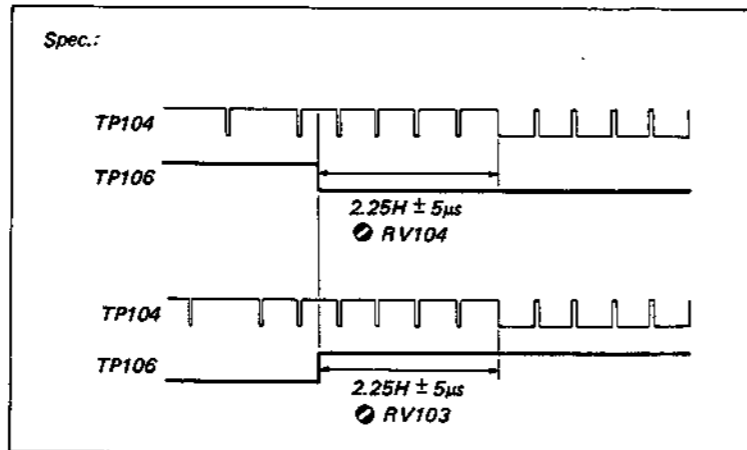

S/N UP TO 13730

8-9-9. Drum Phase Adjustment

Tool: Alignment tape, RR5-1SD PAL
Oscilloscope
Extension Board (EX-128)

Check procedure:

- (1) Insert a KCA-60 tape and put the unit into the REC mode.
- (2) Connect the oscilloscope as follows:
CH1: TP102/SV-88A
CH2: TP106/SV-88A
EXT.TRIG: TP106/SV-88A
Check that the waveforms meet the required specification (1).
- (3) Set the TBC switch of the connector panel to OFF.
- (4) If the TBC is inserted in the set, open the Function Control Panel and set the INT TBC switch to BYPASS.
- (5) Connect the oscilloscope to TP104 on the SV-88A Board.
- (6) Playback the color-bar signal portion of the alignment tape.
- (7) Magnify the playback H period and adjust the edge of first H signal to center of the oscilloscope.
- (8) Check that timing difference of the falling edge between the SEARCH STILL mode and PLAY mode meets the required specification (2).
- (9) Insert a KCA-60 tape wound to the tape beginning portion and put the unit into the SEARCH X 10 mode. Check that H difference is within the specification (3).
- (10) After adjustment, reset the TBC switch, INT TBC switch and S201, S202 on the SV-88A Board.

Adjustment procedure:

- (1) Set the TBC switch of the connector panel to OFF.
- (2) If the TBC is inserted in the set, open the Function Control Panel and set the INT TBC switch to BYPASS. Short between TP509 and GND with shorting clip.

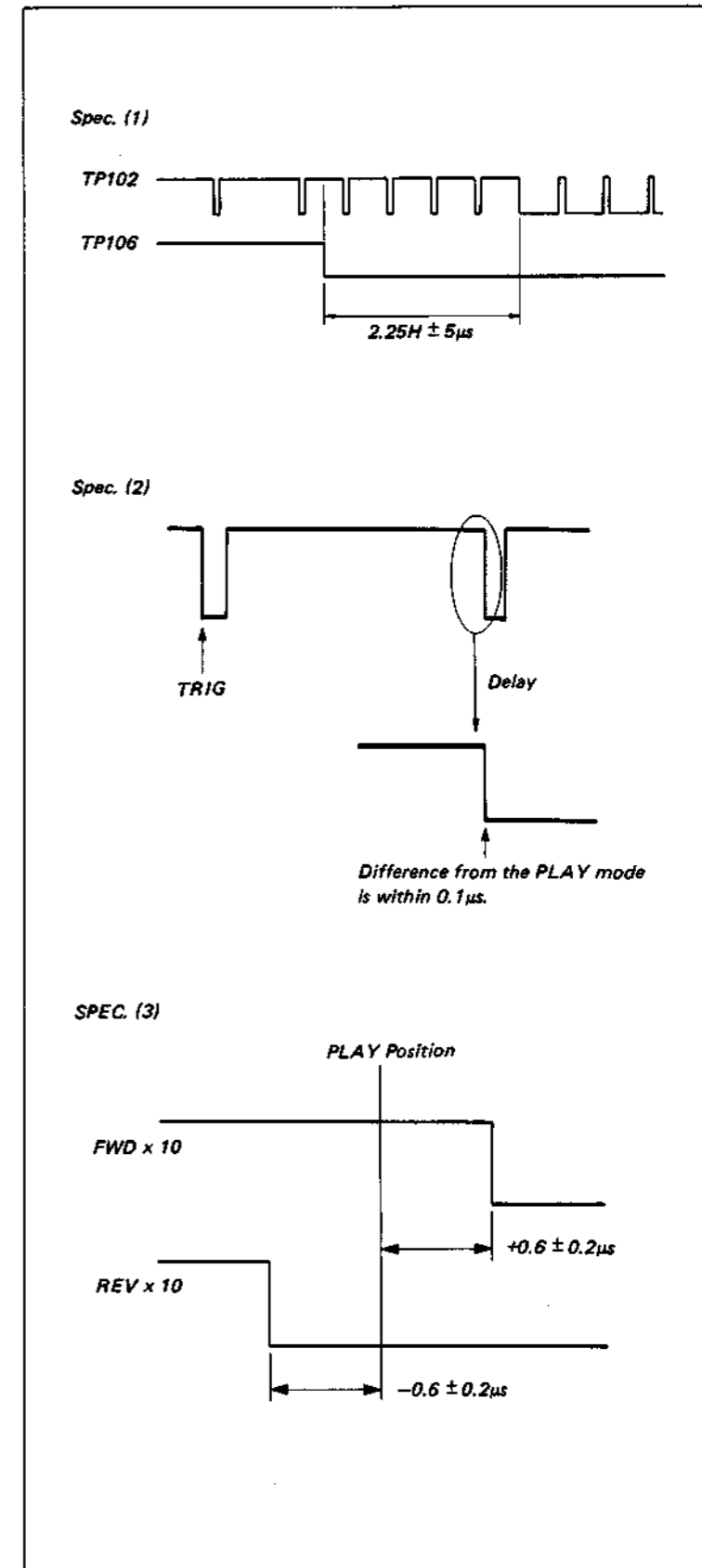

S/N 13731 AND HIGHER

8-9-8. Switching Position Adjustment

Tools: Alignment tape, RR5-1SD PAL
Oscilloscope
Extension board (EX-127, 128)

Preparation:

- (1) Set the Bit8 of S101 on the SV-113 Board to ON. (Release the H-Lock.)
- (2) Connect the oscilloscope as follows:
CH1: TP306/SV-113
CH2: TP106/SV-113

Check procedure:

- (1) Playback the color bar signal portion and check switching pulse waveform meets the required specification. If it meets the required specification, reset the Bit8 of S101 to OFF.

Adjustment Procedure:

- (1) Set the S301 and Bit7 of S101 pm the SV-113 Board to ON.
- (2) Raise the Function Control Panel and remove the Sub Control Panel. Short between TP11 and E1 on the SY-102A Board with a shorting clips. (Refer to Section 4-7)
- (3) Set the CTL/TC/DIAL MENU switch to "DIAL MENU" and set the REMOTE/LOCAL switch to "LOCAL".
- (4) Press the Search Dial and put the unit into the JOG mode.
- (5) While pressing the MENU button, turn the search dial so that the counter value is set to "505".
- (6) Turn the Search Dial and blink the left column of the Time Counter. While pressing the DATA button, turn the dial and adjust to "8".
Adjust the second column from the left of the Time Counter to "b" as described in step (5). (fig.1)
- (7) Press the S102 or S103 and adjust the waveform (CH-B) to meet the required specification.

- (3) Set the Bit 2 of S201 on the SV-88A Board to ON. Check that the Bit 1 of S201 and S202 is set to OFF.
- (4) Insert the alignment tape and put the unit into the STILL mode.
- (5) Connect the oscilloscope as follows:
CH1: TP505/SV-88A
CH2: TP512/SV-88A
Adjust the RV507 so that the voltage of TP505 and TP512 are the same.
- (6) Put the unit into the PLAY and STILL modes alternately, adjust RV506 until the voltage levels of TP505 at the PLAY mode and STILL mode are the same. After the adjustment is completed, remove the shorting clip from TP509.
- (7) Perform the check procedure. If dose not meet spec.(1), perform the adjustment procedure (4) to (6).
- (8) Connect the oscilloscope to TP104 on the SV-88A Board.
- (9) Playback the color-bar signal portion of the alignment tape.
- (10) Magnify the playback H period and adjust the edge of first H signal to senter of the oscilloscope.
- (11) Check that timing difference of the falling edge between the SEARCH STILL mode and PLAY mode meets the required specification (2).
- (12) If does not meet the spec.(2), perform the steps (3) to (7).
- (13) Insert a KCA-60 tape wound to the tape beginning portion and put the unit into the SEARCH X 10 mode. Check that H difference is within the specification (3).
- (14) After adjustment, reset the TBC switch, INT TBC switch and S201, S202 on the SV-88A Board.

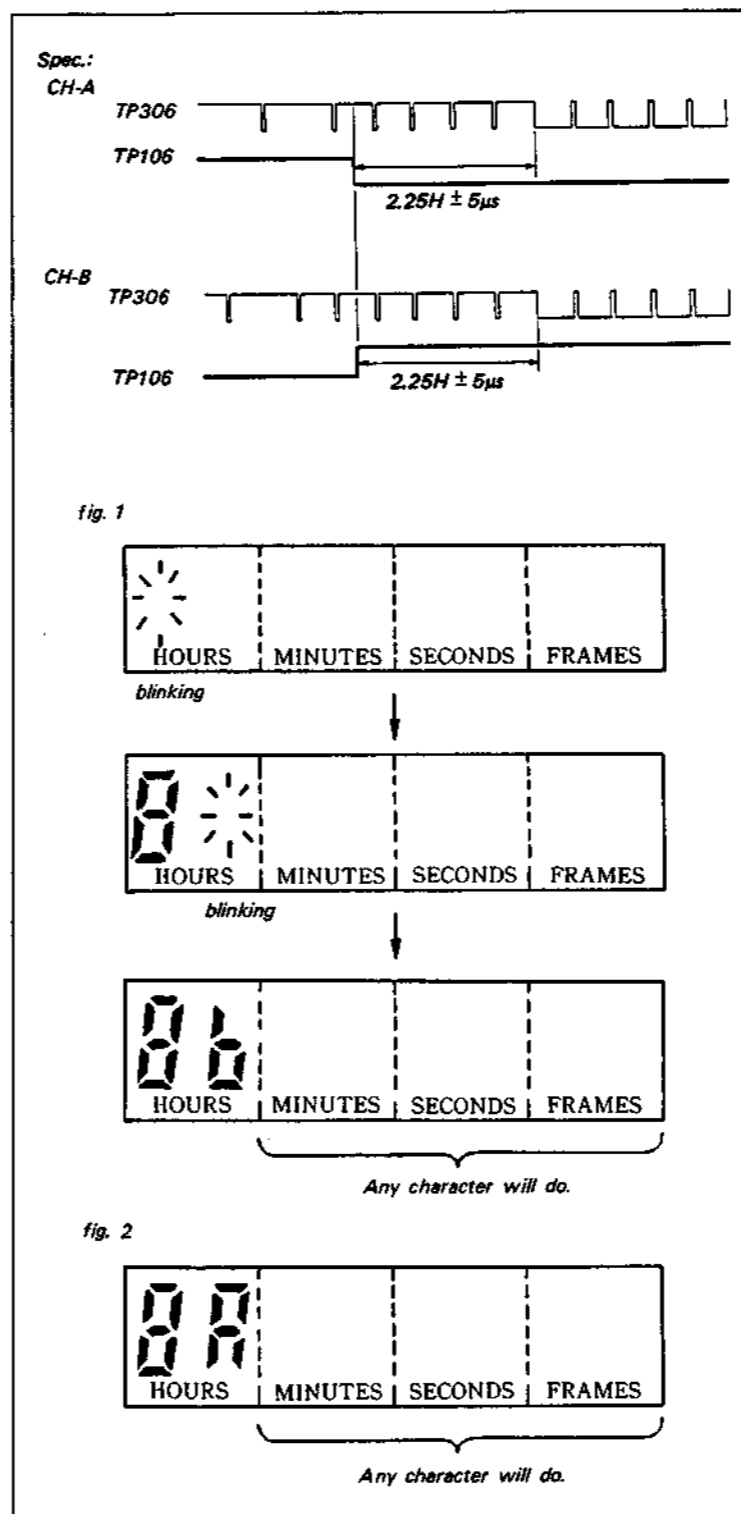

- (8) When it meets the required specification, press the S302 and keep the adjustment data.
- (9) Adjust the left column of the Time Counter to "8" and second column from the left to "A" as described in step (5). (fig.2)
- (10) Press the S102 or S103 and adjust the waveform (CH-A) to meet the required specification.
- (11) When it meets the required specification, press the S302 and keep the adjustment data.
- (12) Set the S301 and Bit7 of S101 on the SV-113 Board to OFF. Set the Bit8 of S101 on the SV-113 Board to OFF. Remove the shorting clips from the SY-102A Board Set the CTL/TC/DIAL MENU switch to "CTL" or "TC".

8-10. VIDEO HEAD DIHEDRAL ADJUSTMENT

. When a TBC Board is installed in the unit, remove it so that the video signal may be output without the TBC Board.

Tool: Dihedral adjustment screwdriver
Alignment tape, RR5-1SD PAL
Monitor TV

Preparation:

- (1) Connect the video monitor TV to the VIDEO OUT connector on the connector panel.
- (2) Playback the monoscope signal portion of the alignment tape.

Check procedure

- (1) Check the distortion of the monoscope signal under the switching pulse. If the clearance between the separate lines is within the width of a single vertical line, adjustment is not necessary. If the clearance of the separate lines is more than the width of a vertical line, then adjustment is necessary.

Adjustment procedure:

- (1) Press the STOP button and then press the STANDBY button. The rotation of the drum is stopped.
- (2) Insert an eccentric screwdriver into the adjustment hole which is near "A" on the printed circuit board at the center of the drum, and perform the dihedral adjustment.
- (3) Press the PLAY button.
- (4) If the distortion has become worse, insert an eccentric screwdriver in the other adjustment hole and perform the dihedral adjustment.

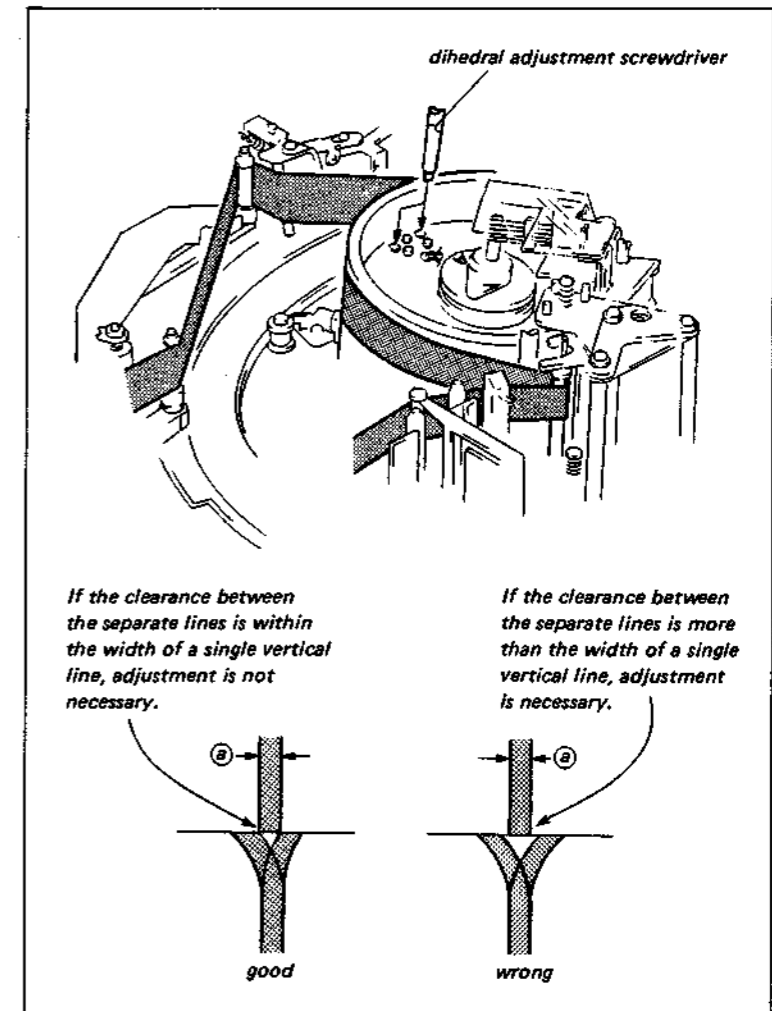

SECTION 9 POWER SUPPLY/SYSTEM CONTROL ALIGNMENT

[Equipment Required]

- DC Voltmeter.

9-1. DC VOLTAGE REGULATOR (UR-21B) ADJUSTMENT

Load for adjustment

- +12V: CN251-5, 6/UR-21B, 2.4Ω 80W
- 12V: CN251-7/UR-21B, 6.2Ω 30W
- +5V: CN201-1, 2/UR-21B, 1.2Ω 30W
- 5V: CN201-7/UR-21B, 2Ω 15W

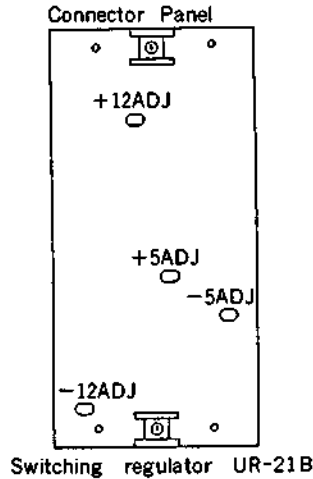

machine conditions for adjustment	spec.	adjustment
<ul style="list-style-type: none"> • Remove the power panel on the connector panel. • Remove the switching regulator connectors (CN430, 431 and 432) from the main unit. • Attach the load. • Connect the AC connector and turn on the power. • Using an alignment tool, adjust the voltage from the outside of the switching regulator's outer cabinet. (NOTE) After the voltage is stabilized, adjust quickly in short time. • After the adjustment is completed, install the switching regulator and power panel. 	<ul style="list-style-type: none"> • +12V adjustment <p style="text-align: center;">$+12.1 \pm 0.1\text{Vdc}$</p>	switching regulator ●RV51/UR-21B-C2
	<ul style="list-style-type: none"> • -12V adjustment <p style="text-align: center;">$-12.1 \pm 0.1\text{Vdc}$</p>	switching regulator ●RV251/UR-21B-M2
	<ul style="list-style-type: none"> • +5V adjustment <p style="text-align: center;">$+5.1 \pm 0.1\text{Vdc}$</p>	switching regulator ●RV51/UR-21B-C1
	<ul style="list-style-type: none"> • -5V adjustment <p style="text-align: center;">$-5.1 \pm 0.1\text{Vdc}$</p>	switching regulator ●RV201/UR-21B-M1

9-2. TAPE SENSOR BALANCE ADJUSTMENT

machine conditions for adjustment	spec.	adjustment
<ul style="list-style-type: none"> • POWER sw : OFF • Short between TP4/SY-102A and GND with a shorting clip. • POWER sw : ON • After the adjustment is completed, remove the shorting clip. • DC Voltmeter 	<p>TP3/SY-102A</p> <p style="text-align: center;">$6.0 \pm 0.2Vdc$</p>	<p>RV1/SY-102A</p>

SECTION 10 SERVO SYSTEM ALIGNMENT

S/N UP TO 13730

[Equipment Required]

- Dual Trace Oscilloscope.
- Frequency Counter.
- DC Voltmeter.
- Cassette tape: KCA-60 or KSP-60
- Alignment Tape: RR5-1SD PAL (Parts No. 8-960-036-81) —SP tape—

TIME	VIDEO	AUDIO	TIME CODE
5	color bars	—	—
3	Gated sweep (B/W)	1kHz, 0dB	—
3	Gated sweep (color)	10kHz, -10dB	—
3	Pulse & bar (color) (MOD 10T and inverted 2T)	1kHz, -20dB (NR: OFF) 40Hz, -20dB (NR: OFF) 7kHz, -20dB (NR: OFF) 10kHz, -20dB (NR: OFF) 15kHz, -20dB (NR: OFF)	—
3	Monoscope (color)	1kHz, -20dB (NR: OFF) 15Hz, -20dB (NR: OFF)	—
3	Pseudo color bars	—	TIME CODE

- For the reel servo adjustment, refer to Section 6 Link and Drive System Alignment and Section 7 Torque System Alignment.

RV601/SV-88A (O-5) 6-3-2 Supply Tension Detector Sensitivity Adjustment

RV602/SV-88A (P-5) 6-4-3 Take-up Tension Detector Sensitivity Adjustment

RV1/DR-53 7-4-1. S Reel Motor Current Sensitive Adjustment

RV2/DR-53 7-4-2. T Reel Motor Current Sensitive Adjustment

- For the switching position adjustment and drum lock phase and drum AFC check, refer to Section 8 Tape Run Alignment.

RV103/SV-88A(D-1) }
RV104/SV-88A(E-1) } 8-9-8. Switching Position Adjustment

- Extend by using the EX-128 Extension Board to adjust the SV-88A board.
- VIDEO IN connector: Color-bar

10-1. D/A AMPLITUDE ADJUSTMENT

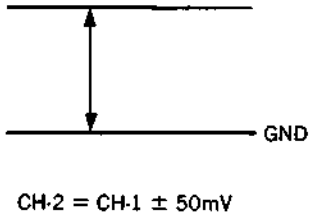
machine conditions for adjustment	spec.	adjustment
<ul style="list-style-type: none"> • Fully turn RV402/SV-88A(G-4) counterclockwise (when viewed from the component side). • S201/SV-88A(K-1): Nos.5 and 6 ON • S202/SV-88A(M-1): ON • EJECT mode • After the adjustment is completed, return S201 and S202 to the former positions. 	<p>CH-1: TP403/SV-88A(Q-5) CH-2: TP405/SV-88A(I-5)</p>  <p style="text-align: center;">$CH-2 = CH-1 \pm 50mV$</p>	<p>RV402/SV-88A(G-4)</p>

10-2. VERTICAL SEP EN PULSE ADJUSTMENT

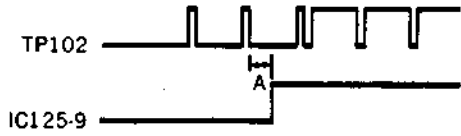
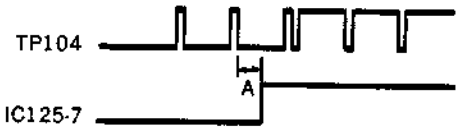
machine conditions for adjustment	spec.	adjustment
<ul style="list-style-type: none"> • EJECT mode 	<p>Step 1 CH-1: TP102/SV-88A(D-3) CH-2: IC125-⑨ pin/SV-88A(E-3)</p>  <p style="text-align: center;">$A = 14 \pm 1 \mu s$</p> <p style="text-align: right;">TRIG: CH-1(V Sync)</p>	<p>RV101/SV-88A(E-3)</p>
	<p>Step 2 CH-1: TP104/SV-88A(D-6) CH-2: IC125-⑦ pin/SV-88A(E-3)</p>  <p style="text-align: center;">$A = 14 \pm 1 \mu s$</p> <p style="text-align: right;">TRIG: CH-1(V Sync)</p>	<p>RV102/SV-88A(E-4)</p>

10-3. CAPSTAN FG BIAS ADJUSTMENT

Step 1. (FG-A)

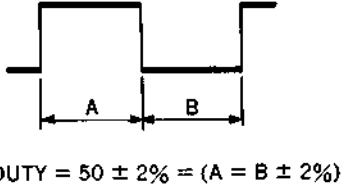
machine conditions for adjustment	spec.	adjustment
<ul style="list-style-type: none"> • S201/SV-88A(K-1): No.3 ON • PB mode • After the adjustment is completed, return S201 to the former position. 	<p>TP501/SV-88A(L-6)</p>  <p>DUTY = 50 ± 2% = (A = B ± 2%)</p>	<p>RV502/SV-88A(L-7)</p>

Step 2. (FG-B)

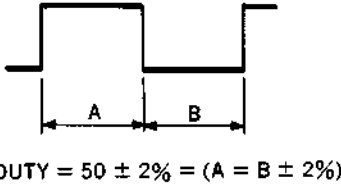
machine conditions for adjustment	spec.	adjustment
<ul style="list-style-type: none"> • S201/SV-88A(K-1): No.3 ON • PB mode • After the adjustment is completed, return S201 to the former position. 	<p>TP502/SV-88A(M-6)</p>  <p>DUTY = 50 ± 2% = (A = B ± 2%)</p>	<p>RV503/SV-88A(L-6)</p>

10-4. DRUM FREE SPEED ADJUSTMENT

Step 1.

machine conditions for adjustment	spec.	adjustment
<ul style="list-style-type: none"> • Insert the alignment tape RR5-1SD PAL • SEARCH • STILL mode • Measure the voltage at TP505 and TP512 using a dc voltmeter. • INT TBC sw: BYPASS • EXT TBC sw: OFF 	TP505/SV-88A(H-6) TP512/SV-88A(H-6) $(TP505) = (TP512) \pm 10mV$ * The voltage at TP505 and TP512 should be $2.5 \pm 0.15V_{dc}$ relative to ground.	ⒶRV507/SV-88A(H-6)

Step 2.

machine conditions for adjustment	spec.	adjustment
<ul style="list-style-type: none"> • Short between TP509/SV-88A (E-6) and GND with shorting clip. • Insert the alignment tape RR5-1SD PAL • S201/SV-88A(K-1): No.2 ON • Repeat the mode from STILL to PLAY and vice versa. • INT TBC sw: BYPASS • EXT TBC sw: OFF • After the adjustment is completed, return S201 to the former position and remove the shorting clip. 	TP505/SV-88A(H-6) The voltage difference in the STILL and PLAY modes should be within $\pm 50mV$.	ⒶRV506/SV-88A(H-5)

10-5. TRACKING CONTROL ADJUSTMENT

machine conditions for adjustment	spec.	adjustment
<ul style="list-style-type: none"> Set the TRACKING control on the front panel to the center click position. STOP mode Connect a dc voltmeter between TP407/SV-88A(Q-6)(+) and GND(-). 	<p>Between TP407/SV-88A(Q-6) and GND</p> <p>$2.5 \pm 0.1 \text{Vdc}$</p>	<ul style="list-style-type: none"> RV404/SV-88A(Q-8)

10-6. SKEW CONTROL ADJUSTMENT

machine conditions for adjustment	spec.	adjustment
<ul style="list-style-type: none"> Set the SKEW control on the Front Panel to the center click position. STOP mode Connect a dc voltmeter between TP408/SV-88A(Q-6)(+) and GND(-). 	<p>Between TP408/SV-88A(Q-6) and GND</p> <p>$2.5 \pm 0.1 \text{Vdc}$</p>	<ul style="list-style-type: none"> RV403/SV-88A(Q-7)

10-7. REEL FG BIAS ADJUSTMENT

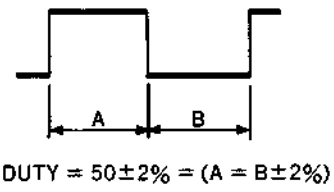
machine conditions for adjustment	spec.	adjustment
<ul style="list-style-type: none"> S201/SV-88A(K-1): No.7 ON S202/SV-88A(M-1): ON STOP mode <p>After the adjustment is completed, return S201 and S202 to the former positions.</p>	<p>Take-up reel(A): TP607/SV-88A(0-6) Take-up reel(B): TP608/SV-88A(0-6) Supply reel(A): TP609/SV-88A(0-6) Supply reel(B): TP610/SV-88A(0-5)</p>  <p>$\text{DUTY} = 50 \pm 2\% = (A = B \pm 2\%)$</p>	<ul style="list-style-type: none"> RV3/SE-48: Take-up reel(A) RV4/SE-48: Take-up reel(B) RV2/SE-48: Supply reel(A) RV1/SE-48: Supply reel(B)

10-8. CAPSTAN FREE SPEED ADJUSTMENT

machine conditions for adjustment	spec.	adjustment
<ul style="list-style-type: none"> • Insert the alignment tape RR5-1SD PAL • S201/SV-88A(K-1): No.3 ON • STILL mode ↔ PLAY mode • Oscilloscope • INT TBC sw: BYPASS • EXT TBC sw: OFF • After the adjustment is completed, return S201 to the former position. 	<p>TP505/SV-88A(I-6)SEARCH • STILL mode TP503/SV-88A(G-7)PLAY mode</p> <p>The voltage difference in the STILL and PLAY modes should be $0 \pm 50\text{mV}$</p>	<p>RV501/SV-88A(F-5)</p>

10-9. CAPSTAN ACCELERATION COMPENSATION ADJUSTMENT

machine conditions for adjustment	spec.	adjustment
<ul style="list-style-type: none"> • Insert the cassette tape KCA-60 or KSP-60 (at the tape center). • Alternately repeat the SEARCH FWD mode at five times and two times normal speed. 	<p>TP602/SV-88A(O-4)</p> <p>$A \approx 2.5\text{Vdc}(\text{reference})$ $B = A \pm 0.25\text{Vdc}$</p>	<p>RV603/SV-88A(E-5)</p>

10-10. TRACKING CONTROL CENTER ADJUSTMENT

machine conditions for adjustment	spec.	adjustment
<ul style="list-style-type: none"> • Set the TRACKING control on the Front Panel to the center click position. • Play back the color bars signal portion of the alignment tape RR5-1SD PAL. 	<p>CH-1: TP204/SV-88A(O-1) CH-2: TP203/SV-88A(J-6)</p> <p>Adjust the trailing edge (Within $\pm 30\mu\text{sec}$). * Adjust at the jitter center.</p> <p>TRIG: CH-1</p>	<p>RV404/SV-88A(Q-8)</p>

10-11. RE MUTING PULSE ADJUSTMENT

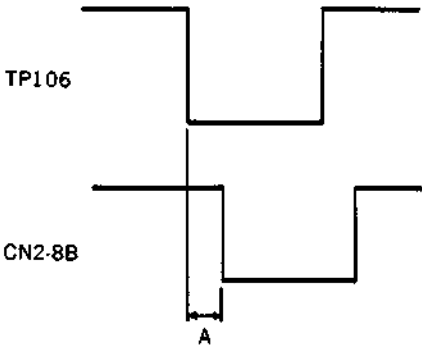
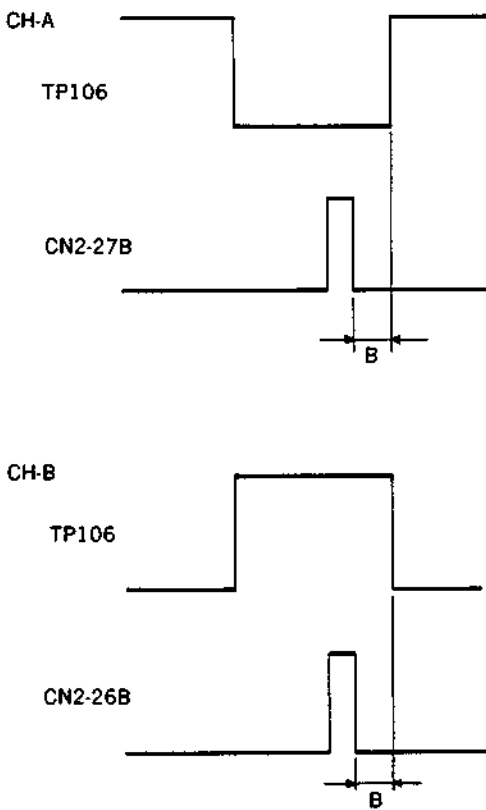
machine conditions for adjustment	spec.	adjustment
<ul style="list-style-type: none"> • Connect between pins 16 and 13 of IC123/SV-88A(B-1) with 1K ohms resistor. • STOP mode 	<p>CH-1: TP106/SV-88A(C-3) CH-2: CN2-8B/SV-88A(C-8)</p>  <p>A = 5.0 ± 0.05 msec</p> <p>TRIG: CH-1</p>	<p>RV105/SV-88A(E-2)</p>
<ul style="list-style-type: none"> • After the adjustment is completed, remove the resistor. 	<p>CH-1: TP106/SV-88A(C-3) CH-2: CN2-27B/SV-88A(F-8), CH-A CN2-26B/SV-88A(F-8), CH-B</p>  <p>B = 3.0 ± 0.05 msec</p> <p>TRIG: CH-1</p>	<p>CH-A: RV107/SV-88A(B-1) CH-B: RV106/SV-88A(B-1)</p>

10-12. REF 135° BURST PULSE ADJUSTMENT

S/N UP TO 10980(EK)

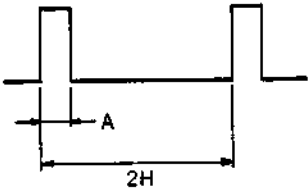
machine conditions for adjustment	spec.	adjustment
<ul style="list-style-type: none"> • EE mode. 	<p>TP702/SV-88A(C-6)</p>  <p style="text-align: center;">$A = 10 \pm 5 \mu s$</p>	<p>RV702/SV-88A(C-6)</p>

10-13. PB 135° BURST PULSE ADJUSTMENT

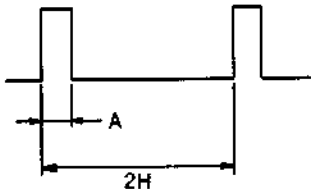
machine conditions for adjustment	spec.	adjustment
<ul style="list-style-type: none"> • Playing back the color bar segment of Alignment tape. 	<p>TP701/SV-88A(B-6)</p>  <p style="text-align: center;">$A = 15 \begin{matrix} +5 \\ -10 \end{matrix} \mu s$</p>	<p>RV701/SV-88A(B-6)</p>

10-14. PICTURE SPLITTING COMPENSATOR ADJUSTMENT

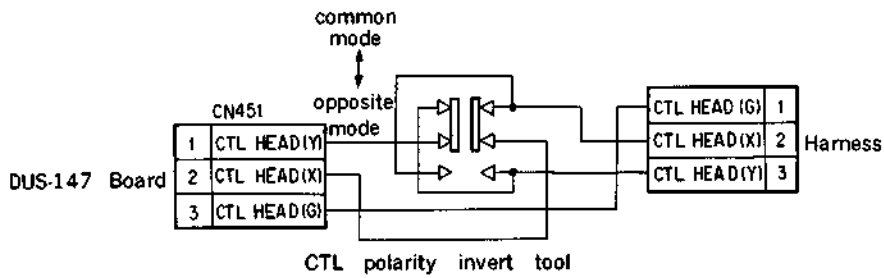

[CONNECTION]

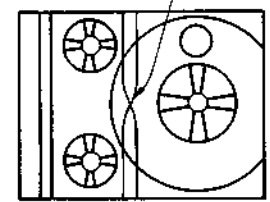

Step 1.

machine conditions for adjustment	spec.	adjustment
<ul style="list-style-type: none"> • VIDEO IN connector: monoscope(B/W) • CTL polarity invert tool: common mode • Play back the self recorded tape. • Set the KCA or KSP cassette tape. • REC mode 	<p>TP507/SV-88A(H-5) Oscilloscope</p>  <p>$A \approx 5\text{mV}_{p-p}$</p>	<p>RV505/SV-88A(H-5)</p>
<ul style="list-style-type: none"> • After the adjustment is completed, keep on the REC mode. • CTL polarity invert tool: opposite mode. • Play back the self recorded portion. 	<p>Monitor</p>  <p>Check the cross point of the vertical line.</p>	

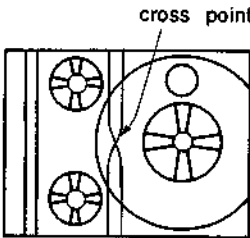
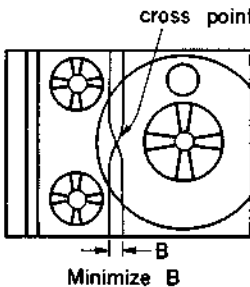
Step 2.

machine conditions for adjustment	spec.	adjustment
<ul style="list-style-type: none"> • VIDEO IN connector: monoscope(B/W) • CTL polarity invert tool: opposite mode • Play back the self recorded tape. 	<p>Monitor</p>  <ol style="list-style-type: none"> 1. Extend the picture splitting by turning RV505/SV-88A(H-5) temporarily. 2. Set the cross point of the vertical line to the position checked in the Step 1. 	<p>RV504/SV-88A(H-5)</p>
	<p>Monitor</p>  <p>note: Check the level of TP507/SV-88A(H-5). This level is CVp-p.</p>	<p>RV505/SV-88A(H-5)</p>
	<p>TP507/SV-88A(H-5)</p>  $D = \frac{1}{2} CV_{p-p}$	<p>RV505/SV-88A(H-5)</p>

Step 3.

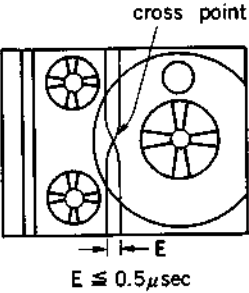
machine conditions for adjustment	spec.	adjustment
<ul style="list-style-type: none"> • VIDEO IN connector: monoscope(B/W) • Set the KCA or KSP cassette Tape. • Record the monoscope signal in the common mode of the CTL polarity invert tool, then play back this tape in the opposite mode of the CTL polarity invert tool. • After the adjustment is completed, remove the CTL polarity invert tool and return the connector to the former position. 	<p>Monitor</p>  <p style="text-align: center;">$E \cong 0.5\mu\text{sec}$</p>	

- If the specification is not satisfied, readjust Step 1 and 2.



S/N 13731 AND HIGHER

[Equipment Required]

- Dual Trace Oscilloscope.
- DC Voltmeter.
- Alignment Tape: RR2-1SD PAL (Parts No. 8-960-036-02) —SP tape—
- Alignment Tape: RR5-1SD PAL (Parts No. 8-960-036-81) —SP tape—

TIME	VIDEO	AUDIO	NR	TIME CODE
5	color bars	—	OFF	—
3	Gated sweep (B/W)	1kHz, 0dB		—
3	Gated sweep (color)	10kHz, -10dB		—
3	Pulse & bar (color) (MOD 10T and inverted 2T)	1kHz, -20dB		—
		40Hz, -20dB		—
		7kHz, -20dB		—
		10kHz, -20dB	—	
		15kHz, -20dB	—	
3	Monoscope (color)	1kHz, -20dB	ON	—
		15 kHz, -20dB		—
3	Pseudo color bars	—	OFF	TIME CODE

- For the reel servo adjustment, refer to Section 6 Link and Drive System Alignment and Section 7 Torque System Alignment.

- RV502/SV-113 (R-7) 6-3-2 Supply Tension Detector Operating Point Adjustment
- RV503/SV-113 (S-7) 6-4-3 Take-up Tension Detector Operating Point Adjustment
- RV1/DR-53 7-4-1. S Reel Motor Current Sensitive Adjustment
- RV2/DR-53 7-4-2. T Reel Motor Current Sensitive Adjustment

- Extend the SV-113 Board with the EX-128 Board.
- REF VIDEO IN connector: Color-bar

10-15. REEL FG BIAS ADJUSTMENT

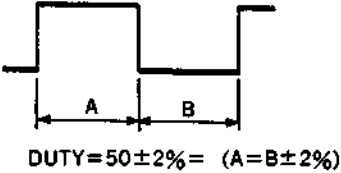
machine conditions for adjustment	spec.	adjustment
<ul style="list-style-type: none"> • S301/SV-113(F-1): ON • S101/SV-113(C-1): No. 6 ON • Connect as follows with shorting clips: TP4/SY-102A(A-5) → GND TP11/SY-102A(K-1) → GND • After the adjustment is completed, return S101 and S301 to the former position and remove the shorting clip. 	<p>Take-up reel(A): TP509/SV-113(R-4) Take-up reel(B): TP510/SV-113(S-5) Supply reel(A): TP511/SV-113(R-5) Supply reel(B): TP512/SV-113(R-4)</p>  <p>DUTY = 50 ± 2% = (A = B ± 2%)</p>	<ul style="list-style-type: none"> ⊙RV3/SE-48: Take-up reel(A) ⊙RV4/SE-48: Take-up reel(B) ⊙RV2/SE-48: Supply reel(A) ⊙RV1/SE-48: Supply reel(B)

[Setting of the Servo Menu]

1. Raise the Key Panel and remove the Sub Control Panel.
2. Set the switches of the Front Panel as follows :
 CTL/TC/DIAL MENU switch => DIAL MENU
 REMOTE/LOCAL switch => LOCAL
3. Connect the TP11 on the SY-102A board and GND with a shorting clip, and select the ITEM 505 in the DIAL MENU MODE.
4. Set the S301 on the SV-113 board to ON.
5. Turn the Search Dial and blink the left column of the Time Counter.



blink

6. While pressing the DATA button, adjust the first figure to 8 and then take off the hand.
7. Turn the Search Dial and blink the second column of the Time Counter.

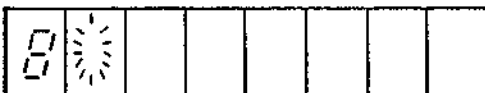

blink

8. While pressing the DATA button, turn the Search Dial and select the adjustment item following the list.
9. Perform the check and adjustment following the adjustment procedures of the each item.
 (The adjustment DATA is renewed when the S302 on the SV-113 board is pressed and the data is written into the memory. While the data is written, the D321 on the SV-113 board is lighting.)
10. Disconnect the shorting clip and set the S301 on the SV-113 board to OFF.
11. Release the DIAL MENU MODE.

< Note >

If the adjustment item is selected with setting ON the S301 on the SV-113 board, the DATA set on the EE-PROM is displayed in the last four columns of the CTL Counter.
 If the adjustment item is changed or the adjustment mode is cancelled without pressing the S302 on the SV-113 board after each adjustment is completed, the preset DATA is set.

ADJUST CONTENTS TABLE



Setting	Adjustment Item	VTR Mode	Display
8100	TRACON/SKEW CENTER	EJECT	VR A/D DATA
8200	DRUM FREE SPEED (MANUAL)	PLAY	PHASE ERROR DATA
8300	CAPSTAN FG(A) DUTY (MANU.)	PLAY	D/A OUTPUT DATA
8400	CAPSTAN FG(B) DUTY (MANU.)	PLAY	D/A OUTPUT DATA
8500	CAPSTAN FREE SPEED (MANU.)	PLAY	PHASE ERROR DATA
8600	CAPSTAN FG DUTY (AUTO)	PLAY	
8700	DRUM FREE SPEED (AUTO)	PLAY	
8800	CAPSTAN FREE SPEED (AUTO)	PLAY	
8900			
8A00	SW POSITION (A)	PLAY	ADJUST DATA
8B00	SW POSITION (B)	PLAY	ADJUST DATA
8C00	PB BACK TENSION	PLAY	ADJUST DATA
8D00	PICTURE SPLITTING GAIN	PLAY	PHASE DATA, GAIN DATA
8E00	PICTURE SPLITTING PHASE	PLAY	PHASE DATA, GAIN DATA
8F00			

10-16. SKEW CENTER ADJUSTMENT

machine conditions for adjustment	spec.	adjustment
<ul style="list-style-type: none"> • Setting of the SERVO MENU. • TRACON VR/SKEW: center clicked position (Front Panel) • STOP mode • While pressing the MENU button, turn the search dial so that the counter value is set to "505". • Turn the search dial while pressing the DATA button to "8100". • Press the S102 on the SV-113 board (B-1) one time. • After the indication of DATA portion is changed, press the S302 on the SV-113 board (E-1) and keep the adjustment data. 	<p>TIME COUNTER</p>	<p>⊙ S102/SV-113(B-1)</p>

10-17. CAPSTAN FG DUTY ADJUSTMENT

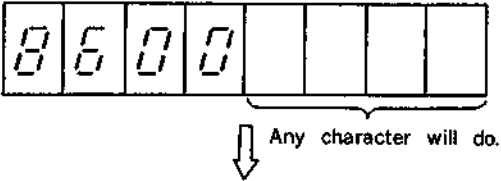
AUTO MODE

machine conditions for adjustment	spec.	adjustment
<ul style="list-style-type: none"> • Setting of the SERVO MENU. • Play back the optional portion of the alignment tape RR5-1SD PAL. • While pressing the MENU button, turn the search dial so that the counter value is set to "505". • Turn the search dial while pressing the DATA button to "8600". • Press the S102 on the SV-113 board (B-1). • When the DATA becomes "8888", press the S302 on the SV-113 board (E-1) and keep the adjustment data. • When the DATA becomes "FFAB", "FFAO" or "FFOB", the adjustment is incorrect. Press the S102 and when the DATA becomes "FFAB", "FFAO" or "FFOB" again, perform the Manual Adjustment. 	<p>TIME COUNTER</p>  	<p>AUTO Adjustment</p>

MANUAL MODE

Step 1. FG-A Adjustment (Error code: "FFAB" or "FFAO")

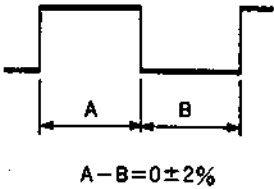
machine conditions for adjustment	spec.	adjustment
<ul style="list-style-type: none"> • Setting of the SERVO MENU. • Play back the optional portion of the alignment tape RR5-1SD PAL • While pressing the MENU button, turn the search dial so that the counter value is set to "505". • Turn the search dial while pressing the DATA button to "8300". • Press the S102 and S103 on the SV-113 board (B-1). • After the adjustment is completed, press the S302 on the SV-113 board (E-1) and keep the adjustment data. 	<p>TIME COUNTER</p>  <p>TP201/SV-113(P-5)</p>  <p>$A - B = 0 \pm 2\%$</p>	<ul style="list-style-type: none"> ⦿ S102/SV-113(B-1) ⦿ S103/SV-113(B-1)

Step 2. FG-B Adjustment (Error code: "FFAB" or "FFOB")

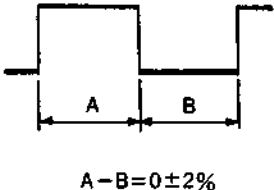
machine conditions for adjustment	spec.	adjustment
<ul style="list-style-type: none"> • Setting of the SERVO MENU. • Play back the optional portion of the alignment tape RR5-1SD PAL • While pressing the MENU button, turn the search dial so that the counter value is set to "505". • While pressing the DATA button, turn the search dial to "8400" • Press the S102 or S103 on the SV-113 board (B-1). • After the adjustment is completed, press the S302 on the SV-113 board (E-1) and keep the adjustment data. 	<p>TIME COUNTER</p>  <p>TP202/SV-113(M-4)</p>  <p>$A - B = 0 \pm 2\%$</p>	<ul style="list-style-type: none"> ⦿ S102/SV-113(B-1) ⦿ S103/SV-113(B-1)

10-18. DRUM FREE SPEED ADJUSTMENT AUTO MODE

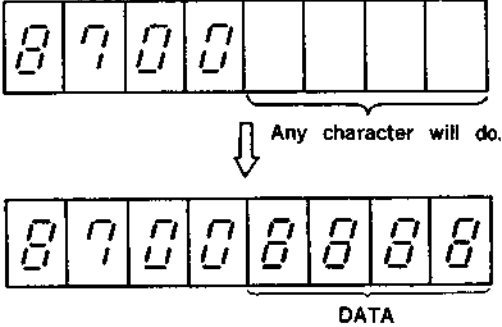
machine conditions for adjustment	spec.	adjustment
<ul style="list-style-type: none"> • Setting of the SERVO MENU. • Play back the optional portion of the alignment tape RR5-1SD PAL. • While pressing the MENU button, turn the search dial so that the counter value is set to "505". • While pressing the DATA button, turn the search dial to "8700". • Press the S102 on the SV-113 board (B-1). • When the DATA becomes "8888", press the S302 on the SV-113 board (E-1) and keep the adjustment data. • When the DATA becomes "FFFF", the adjustment is incorrect. Press the S102 and when the data becomes "FFFF" again, perform the Manual Adjustment. 	<p>TIME COUNTER</p>  <p style="text-align: center;">Any character will do.</p> <p style="text-align: center;">DATA</p>	<p>AUTO Adjustment</p>

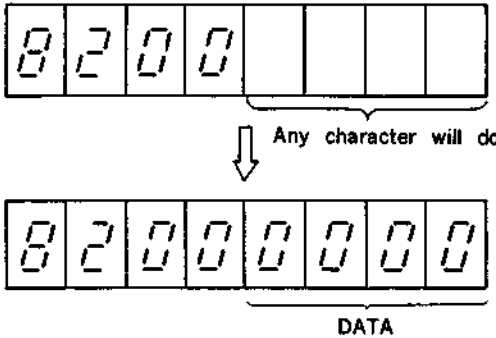

MANUAL MODE

machine conditions for adjustment	spec.	adjustment
<ul style="list-style-type: none"> • Setting of the SERVO MENU. • Play back the optional portion of the alignment tape RR5-1SD PAL. • While pressing the MENU button, turn the search dial so that the counter value is set to "505". • While pressing the DATA button, turn the search dial to "8200". • Press the S102 or S103 on the SV-113 board (B-1). • After the adjustment is completed, press the S302 on the SV-113 board (E-1) and keep the adjustment data. 	<p>TIME COUNTER</p>  <p style="text-align: center;">Any character will do.</p> <p style="text-align: center;">DATA</p> <p style="text-align: center;">DATA="0000±10"</p> <p style="text-align: center;">Adjust the DATA to change while "0000" as a center.</p>	<ul style="list-style-type: none"> ⦿ S102/SV-113(B-1) ⦿ S103/SV-113(B-1)

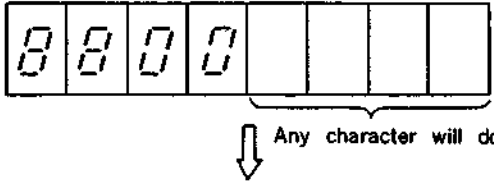
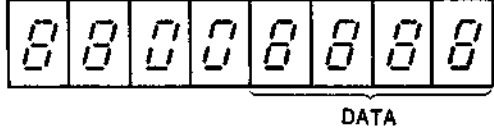
**10-19. CAPSTAN FREE SPEED ADJUSTMENT
AUTO MODE**

machine conditions for adjustment	spec.	adjustment
<ul style="list-style-type: none"> • Setting of the SERVO MENU. • Play back the optional portion of the alignment tape RR5-1SD PAL • While pressing the MENU button, turn the search dial so that the counter value is set to "505". • While pressing the DATA button, turn the search dial to "8800". • Press the S102 on the SV-113 board (B-1). • When the DATA becomes "8888", press the S302 on the SV-113 board (E-1) and keep the adjustment data. • When the DATA becomes "FFFF", the adjustment is incorrect. Press the S102 and when the data becomes "FFFF" again, perform the Manual Adjustment. 	<p>TIME COUNTER</p>  	<p>AUTO Adjustment</p>

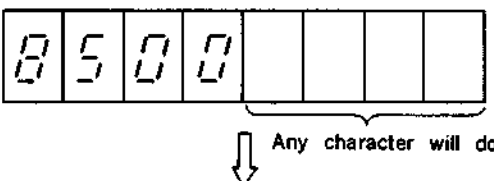
MANUAL MODE

machine conditions for adjustment	spec.	adjustment
<ul style="list-style-type: none"> • Setting of the SERVO MENU. • Play back the optional portion of the alignment tape RR5-1SD PAL • While pressing the MENU button, turn the search dial so that the counter value is set to "505". • While pressing the DATA button, turn the search dial to "8500". • Press the S102 or S103 on the SV-113 board (B-1). • After the adjustment is completed, press the S302 on the SV-113 board (E-1) and keep the adjustment data. 	<p>TIME COUNTER</p>   <p style="text-align: center;">DATA="0000±10"</p> <p style="text-align: center;">Adjust the DATA to change while "0000" as a center.</p>	<ul style="list-style-type: none"> Ⓞ S102/SV-113(B-1) Ⓞ S103/SV-113(B-1)

10-20. 135° BURST PULSE ADJUSTMENT

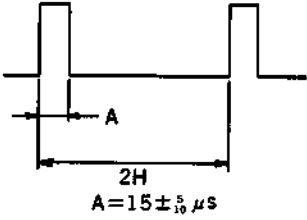
machine conditions for adjustment	spec.	adjustment
<ul style="list-style-type: none"> • Play back the color-bar segment of the alignment tape RR5-1SD PAL 	<p>TP601/SV-113(F-4)</p>  <p>$A = 15 \pm 0.5 \mu s$</p>	<p>RV601/SV-113(F-5)</p>

10-21. PICTURE SPLITTING COMPENSATOR ADJUSTMENT

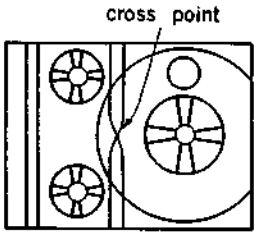
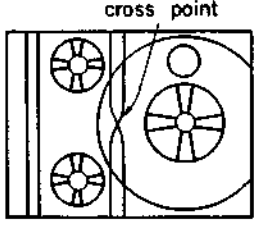
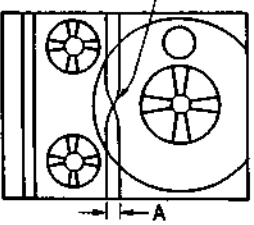
machine conditions for adjustment	spec.	adjustment
<p>Step 1.</p> <ul style="list-style-type: none"> • Setting of the SERVO MENU. • While pressing the MENU button, turn the search dial so that the counter value is set to "505". • While pressing the DATA button, turn the search dial to "8d00". • VIDEO IN connector: monoscope (B/W) • Play back the self recorded tape. • After check the cross point of the vertical line, press the S102 or S103 on the SV-113 board (B-1) and extend the picture splitting. 	<p>TIME COUNTER</p> <p>(1) </p> <p>(2) </p> <p>Check the cross point of the vertical line.</p> <p>(3) Extend the picture splitting purposely.</p>	<ul style="list-style-type: none"> ⚙ S102/SV-113(B-1) ⚙ S103/SV-113(B-1)
<p>Step 2.</p> <ul style="list-style-type: none"> • While pressing the DATA button, Turn the search dial to "8E00". 	<p>MONITOR</p> <p></p> <p>Set the cross point of the vertical line to the position checked in the STEP 1.</p>	<ul style="list-style-type: none"> ⚙ S102/SV-113(B-1) ⚙ S103/SV-113(B-1)
<p>Step 3.</p> <ul style="list-style-type: none"> • While pressing the DATA button, turn the search dial to "8d00". • After the adjustment is completed, press the S302 on the SV-113 board (E-1) and keep the adjustment data. 	<p>MONITOR</p> <p></p> <p>Minimize A</p>	<ul style="list-style-type: none"> ⚙ S102/SV-113(B-1) ⚙ S103/SV-113(B-1)

- If it is out of the specification, perform Step 1, 2 and 3 again.



SECTION 11 AUDIO SYSTEM ALIGNMENT

[Equipment Required]

- Dual Trace Oscilloscope.
- Frequency Counter.
- Audio Oscillator.
- AC Voltmeter.
- Audio Attenuator.
- Cassette Tape: KCA, KCS and KSP. (When adjusting, use KCA and KCS unless otherwise specifically indicated.)
- KSP Blank Tape (Blank Tape is no signal recorded tape.)
- Alignment Tape: RR5-1SD PAL (Part No. 8-960-036-81)—SP tape—

TIME	VIDEO	AUDIO	TIME CODE
5	color bars	—	—
3	Gated sweep (B/W)	1kHz, 0dB	—
3	Gated sweep (color)	10kHz, -10dB	—
3	Pulse & bar (color) (MOD 10T and inverted 2T)	1kHz, -20dB (NR: OFF) 40Hz, -20dB (NR: OFF) 7kHz, -20dB (NR: OFF) 10kHz, -20dB (NR: OFF) 15kHz, -20dB (NR: OFF)	—
3	Monoscope (color)	1kHz, -20dB (NR: ON) 15 kHz, -20dB (NR: ON)	—
3	Pseudo color bars	—	TIME CODE

[Switch/VR Setting]

Front Panel

- AUDIO LEVEL CH-1(PB, REC)VR Counterclockwise
- AUDIO LEVEL CH-2(PB, REC)VR Counterclockwise
- HEADPHONE LEVEL VR Counterclockwise
- AUDIO MONITOR sw MIX
- TRACKING VR FIXED
- AUDIO LIMITER sw OFF
- INPUT SELECT sw LINE
- REMOTE/LOCAL SELECT sw LOCAL
- PB, PB/EE SELECT sw PB/EE
- DOLBY NR sw (behind panel) OFF
- VIDEO LEVEL sw AUTO
- SKEW CLICK position

Rear Panel

- AUDIO IN LEVEL sw LOW

DO not move these switches and volumes unless otherwise specified.

VIDEO IN connector: Color-bar

11-1. AUDIO REC LEVEL SETTING

machine conditions for adjustment	spec.	adjustment
<ul style="list-style-type: none"> • AUDIO IN connector: 1kHz, -60dBm • EE mode 	CH-1: TP4/AU-83A(F-6) CH-2: TP4/AU-84A(E-1) $-10 \pm 0.2\text{dBs}$	Ⓐ REC LEVEL VR (Front panel)

NOTE: The AUDIO REC LEVEL control should not be touch until rest of Sec.11 Audio System Alignment completed.

11-2. AUDIO OUTPUT LEVEL ADJUSTMENT

machine conditions for adjustment	spec.	adjustment
<ul style="list-style-type: none"> • AUDIO IN connector: 1kHz, -60dBm • EE mode 	CH-1: AUDIO OUT connector CH-2: AUDIO OUT connector (terminated by 600Ω) $+4 \pm 0.5\text{dBm}$ (CH-1 level = CH-2 level)	CH-1: Ⓐ RV1/AU-87(E-2) CH-2: Ⓐ RV2/AU-87(D-2)

11-3. AUDIO MONITOR OUTPUT LEVEL ADJUSTMENT

machine conditions for adjustment	spec.	adjustment
<ul style="list-style-type: none"> • AUDIO IN connector: 1kHz, -60dBm • EE mode • AUDIO MONITOR sw: CH-1 	AUDIO OUT connector (terminated by 600Ω) $+4 \pm 0.5\text{dBm}$	Ⓐ RV3/AU-87(D-2)

11-4. AUDIO LEVEL METER ADJUSTMENT

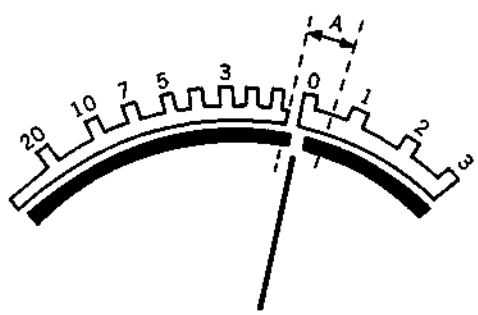
machine conditions for adjustment	spec.	adjustment
<ul style="list-style-type: none"> AUDIO IN connector: 1kHz, - 60dBm EE mode 	<p>AUDIO LEVEL meter</p>  <p>$A = 0 \pm 0.5\text{dB}$</p>	<p>CH-1: Ⓢ RV12/AU-83A(E-6) CH-2: Ⓢ RV12/AU-84A(E-1)</p>

11-5. LIMITER LEVEL ADJUSTMENT

machine conditions for adjustment	spec.	adjustment
<ul style="list-style-type: none"> Extend the AU-83A Board and the AU-84A Board by using the EX-127 Extension Board. AUDIO IN connector: 1kHz, - 30dBm EE mode LIMITER sw: ON 	<p>AUDIO OUT connector (terminated by 600Ω)</p> <p>$+ 7 \pm 0.5\text{dBm}$ (CH-1 level = CH-2 level)</p>	<p>CH-1: Ⓢ RV7/AU-83A(D-1) CH-2: Ⓢ RV7/AU-84A(D-5)</p>

11-6. PB FREQUENCY RESPONSE ADJUSTMENT

machine conditions for adjustment	spec.	adjustment
<ul style="list-style-type: none"> Extend the AU-83A Board and the AU-84A Board by using the EX-127 Extension Board. Play back the audio 1kHz, 7kHz, and 15kHz segments of alignment tape. 	<p>AUDIO OUT connector (terminated by 600Ω)</p> <p>1kHz Level = Ref, Level</p> <p>7kHz Level = (Ref, Level) $\pm 0.2\text{dB}$ 15kHz Level = (Ref, Level) $\pm 0.7\text{dB}$</p> <p>Repeat the sequence of checks and adjustment at 1kHz, 7kHz and 15kHz until specifications are satisfied at a same time.</p>	<p>7kHz CH-1: Ⓢ RV4/AU-83A(G-3) CH-2: Ⓢ RV4/AU-84A(A-4)</p> <p>15kHz CH-1: Ⓢ RV3/AU-83A(G-2) CH-2: Ⓢ RV3/AU-84A(A-4)</p> <p>CH-1: Ⓢ RV5/AU-83A(G-6) CH-2: Ⓢ RV5/AU-84A(B-1)</p>

11-7. PB OUTPUT LEVEL ADJUSTMENT

machine conditions for adjustment	spec.	adjustment
<ul style="list-style-type: none"> Play back the audio 1kHz, 0dB segment of alignment tape. 	CH-1: TP4/AU-83A(F-6) CH-2: TP4/AU-84A(E-1) $- 10 \pm 0.2\text{dBs}$	CH-1: ⓪ RV6/AU-83A(F-6) CH-2: ⓪ RV6/AU-84A(B-1)

11-8. AUDIO PB LEVEL SETTING

machine conditions for adjustment	spec.	adjustment
<ul style="list-style-type: none"> Play back the audio 1kHz, 0dB segment of alignment tape. 	AUDIO OUT connector (terminated by 600Ω) $+ 4 \pm 0.3\text{dBm}$	⓪ PB LEVEL VR (Front panel) Perform CH-1, CH-2

NOTE: The AUDIO PB LEVEL control should not be touch until rest of Sec.11 Audio System Alignment completed.

11-9. SPECTRAL SKEWING ADJUSTMENT

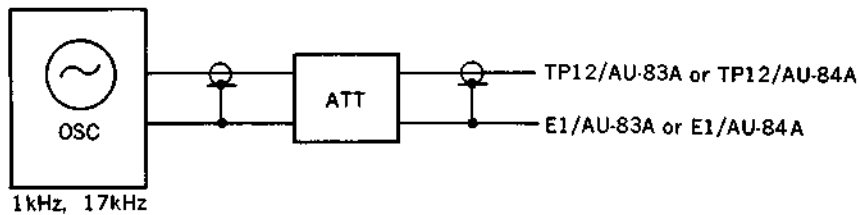

machine conditions for adjustment	spec.	adjustment
<ul style="list-style-type: none"> Extend the AU-83A Board and the AU-84A Board by using the EX-127 Extension Board. Connect the OSC and ATT. EE mode DOLBY NR sw: ON Before Adjustment, set the level at TP4/AU-83A(F-6) and TP4/AU-84A(E-1) by ATT to 1kHz, $- 10 \pm 0.1\text{dBs}$. 	CH-1: TP4/AU-83A(F-6) CH-2: TP4/AU-84A(E-1) $1\text{kHz} = - 10 \pm 0.1\text{dBs}$ $17\text{kHz} = - 18.3 \pm 0.1\text{dBs}$	CH-1: ⓪ LV5/AU-83A(E-4) CH-2: ⓪ LV5/AU-84A(D-3)

11-10. PB PILOT TONE LEVEL ADJUSTMENT

machine conditions for adjustment	spec.	adjustment
<ul style="list-style-type: none"> • Extend the AU-85A Board by using the EX-127 Extension Board. • AUDIO IN connector: 1kHz, - 60dBm • Play back the monoscope segment of alignment tape. 	CH-1: TP15/AU-85A(E-6) CH-2: TP16/AU-85A(D-6)  $A = 0.5 \begin{matrix} + 0.1 \\ - 0 \end{matrix} V_{pp}$	CH-1: Ⓢ RV3/AU-85A(E-6) CH-2: Ⓢ RV6/AU-85A(D-6)

11-11. PB PILOT TONE PHASE ADJUSTMENT

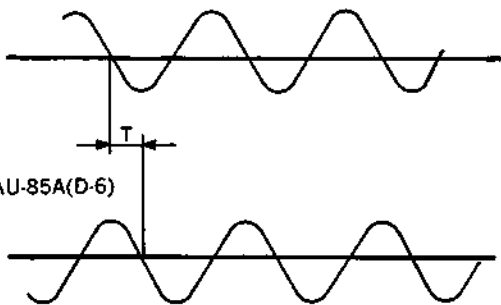
machine conditions for adjustment	spec.	adjustment
<ul style="list-style-type: none"> • Extend the AU-85A Board by using the EX-127 Extension Board. • AUDIO IN connector: 1kHz, - 60dBm • Play back the pulse & bar(B/W) segment of alignment tape. 	TP28/AU-85A(E-6)  TP16/AU-85A(D-6) $T = (0 \pm 15^\circ) \text{ or } (180 \pm 15^\circ)$ TRIG: TP28/AU-85A(E-6)	Ⓢ RV2/AU-85A(G-5)

11-12. PILOT TONE DETECT DC BALANCE ADJUSTMENT

machine conditions for adjustment	spec.	adjustment
<ul style="list-style-type: none"> • Extend the AU-85A Board by using the EX-127 Extension Board. • STOP mode 	CH-1: DC Level at TP17/AU-85A = (DC Level at TP18/AU-85A) ± 50mV CH-2: DC Level at TP20/AU-85A = (DC Level at TP21/AU-85A) ± 50mV	CH-1: Ⓢ RV4/AU-85A(E-4) CH-2: Ⓢ RV7/AU-85A(C-4)

11-13. DOLBY DETECT LEVEL ADJUSTMENT

machine conditions for adjustment	spec.	adjustment
<ul style="list-style-type: none"> • Extend the AU-85A Board by using the EX-127 Extension Board. • STOP mode 	TP19/AU-85A(F-5) $+ 4 \pm 0.05 \text{ Vdc}$	Ⓞ RV5/AU-85A(F-4)

11-14. INSERT MODE ERASE CURRENT ADJUSTMENT

machine conditions for adjustment	spec.	adjustment
<ul style="list-style-type: none"> • Extend the AU-85A Board by using the EX-127 Extension Board. • No signal is supplied to the AUDIO IN connector. • CH-1 INSERT mode • CH-2 INSERT mode 	CH-1: TP4/AU-85A(A-2) CH-2: TP22/AU-85A(G-2) $240 \pm 10 \text{ mVrms}$	CH-1: Ⓞ RV101/AU-85A(B-1) CH-2: Ⓞ RV102/AU-85A(G-1)

11-15. AUDIO ERASE PRE-ADJUSTMENT

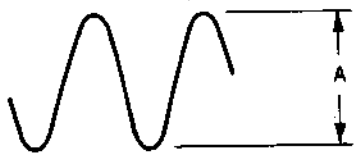
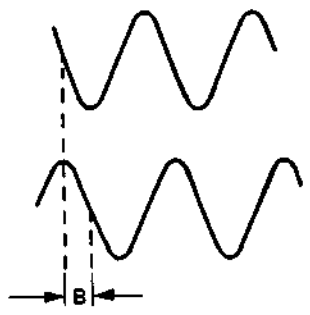
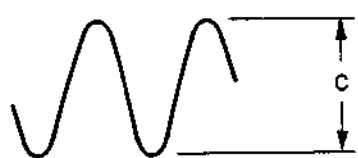
machine conditions for adjustment	spec.	adjustment
<ul style="list-style-type: none"> • Set the KSP cassette tape. • REC mode 	<p>Step. 1</p> <p>CH-1: TP1/AU-85A(B-1)</p> <p>CH-2: TP23/AU-85A(G-1)</p>  <p style="text-align: center;">$A = 12 \pm 0.5V_{p-p}$</p>	<ul style="list-style-type: none"> ⊗ CH-1: LV1/AU-85A(B-1) ⊗ CH-2: LV2/AU-85A(F-1)
	<p>Step. 2</p> <p>CH-1: TP1</p> <p>CH-2: TP23</p>  <p style="text-align: center;">$B = 0 \pm 15^\circ$ ($0 \pm 0.6\mu s$)</p>	
	<p>Step. 3</p>  <p style="text-align: center;">After Step2 is performed, $C = 12 \pm 1V_{p-p}$</p>	

11-16. BIAS LEVEL PRE-ADJUSTMENT

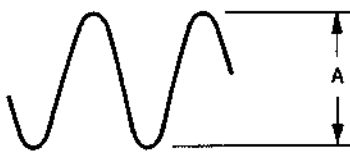
machine conditions for adjustment	spec.	adjustment
<ul style="list-style-type: none"> • Set the KSP cassette Tape. • REC mode 	<p>CH-1: TP7/AU-85A(C-1)</p> <p>CH-2: TP10/AU-85A(E-1)</p>  <p style="text-align: center;">$A = 12.0 \pm 0.5V_{p-p}$</p>	<ul style="list-style-type: none"> ⊗ CH-1: LV3/AU-85A(D-1) ⊗ CH-2: LV5/AU-85A(D-1)

11-17. BIAS OSCILLATOR TUNING ADJUSTMENT

machine conditions for adjustment	spec.	adjustment
<ul style="list-style-type: none"> • Extend the AU-85A Board by using the EX-127 Extension Board. • No signal is supplied to the AUDIO IN connector. • Set the KSP cassette tape. • REC mode 	CH-1: TP9/AU-85A(C-3) CH-2: TP12/AU-85A(E-3) Maximize the amplitude.	CH-1: Ⓐ LV4/AU-85A(C-3) CH-2: Ⓐ LV6/AU-85A(E-3)

11-18. BIAS TRAP ADJUSTMENT

machine conditions for adjustment	spec.	adjustment
<ul style="list-style-type: none"> • Extend the AU-83A Board and the AU-84A Board by using the EX-127 Extension Board. • No signal is supplied to the AUDIO IN connector. • Set the KSP blank tape. • REC mode. 	CH-1: TP11/AU-83A(G-1) CH-2: TP11/AU-84A(B-6) Minimize the Bias leak.	CH-1: Ⓐ LV1/AU-83A(G-1) CH-2: Ⓐ LV1/AU-84A(A-6)

11-19. INSERT BIAS TRAP ADJUSTMENT

machine conditions for adjustment	spec.	adjustment
<ul style="list-style-type: none"> • Extend the AU-83A Board and the AU-84A Board by using the EX-127 Extension Board. • No signal is supplied to the AUDIO IN connector. • Set the KSP blank tape. • CH-1, CH-2 INSERT mode 	CH-1: TP15/AU-83A(G-3)(CH-2 INSERT MODE) CH-2: TP15/AU-84A(B-6)(CH-1 INSERT MODE) Minimize the Bias leak.	CH-1: Ⓐ LV3/AU-83A(G-3) CH-2: Ⓐ LV3/AU-84A(A-4)

11-20. REC BIAS CURRENT LEVEL ADJUSTMENT (SP)

machine conditions for adjustment	spec.	adjustment
<ul style="list-style-type: none"> • AUDIO IN connector: 1kHz/7kHz, -80dBm • Set the KSP cassette tape. • Play back the self recorded tape. 	LINE OUT connector (terminated by 600Ω) 1kHz = 0(REF) 7kHz = 0 ± 0.5dB	CH-1: Ⓞ RV103/AU-85A(C-1) CH-2: Ⓞ RV105/AU-85A(E-1) REC mode → adj. PB mode → check

11-21. REC BIAS CURRENT LEVEL ADJUSTMENT (CONVENTIONAL)

machine conditions for adjustment	spec.	adjustment
<ul style="list-style-type: none"> • AUDIO IN connector: 1kHz/7kHz, -80dBm • Play back the self recorded tape. 	LINE OUT connector (terminated by 600Ω) 1kHz = 0 (REF) 7kHz = 0 ± 0.5dB	CH-1: Ⓞ RV104/AU-85A(C-1) CH-2: Ⓞ RV106/AU-85A(E-1) REC mode → adj. PB mode → check

11-22. REC FREQUENCY RESPONSE ADJUSTMENT (SP)

machine conditions for adjustment	spec.	adjustment
<ul style="list-style-type: none"> • AUDIO IN connector: 40Hz to 15kHz, -80dBm • Set the KSP cassette tape. • Play back the self recorded tape. 	LINE OUT connector (terminated by 600Ω) 40Hz = -1 ^{+1.5} / _{-3.5} dB 90Hz = 0 ± 1.5dB 1kHz = 0 (REF) 3kHz = 0 ± 0.5dB 7kHz = 0 ± 0.5dB 10kHz = 0 ± 0.5dB 15kHz = 0 ± 0.5dB	7kHz CH-1: Ⓞ RV103/AU-85A(C-1) CH-2: Ⓞ RV105/AU-85A(E-1) 10kHz CH-1: Ⓞ LV102/AU-83A(B-5) CH-2: Ⓞ LV203/AU-84A(F-2) 15kHz CH-1: Ⓞ RV11/AU-83A(B-6) CH-2: Ⓞ RV11/AU-84A(E-1) REC mode → adj. PB mode → check

11-23. REC FREQUENCY RESPONSE ADJUSTMENT (CONVENTIONAL)

machine conditions for adjustment	spec.	adjustment
<ul style="list-style-type: none"> • AUDIO IN connector: 40Hz to 15kHz, - 80dBm • Play back the self recorded tape. 	<p>LINE OUT connector (terminated by 600Ω)</p> <p>40Hz = -1 $\begin{matrix} +1.5 \\ -3.5 \end{matrix}$ dB 90Hz = 0 ± 1.5dB 1kHz = 0 (REF) 3kHz = 0 ± 0.5dB 7kHz = 0 ± 0.5dB 10kHz = 0 ± 0.5dB 15kHz = 0 ± 0.5dB</p>	<p>7kHz CH-1: Ⓞ RV104/AU-85A(C-1) CH-2: Ⓞ RV106/AU-85A(E-1)</p> <p>10kHz CH-1: Ⓞ LV103/AU-83A(B-5) CH-2: Ⓞ LV202/AU-84A(F-2)</p> <p>15kHz CH-1: Ⓞ RV10/AU-83A(B-6) CH-2: Ⓞ RV10/AU-84A(F-1)</p> <p>REC mode → adj. PB mode → check</p>

11-24. REC LEVEL ADJUSTMENT (SP)

machine conditions for adjustment	spec.	adjustment
<ul style="list-style-type: none"> • AUDIO IN connector: 1kHz, - 60dBm • Set the KSP cassette tape. • Play back the self recorded tape. 	<p>AUDIO OUT connector (terminated by 600Ω)</p> <p>+ 4 ± 0.3dBm</p>	<p>CH-1: Ⓞ RV8/AU-83A(B-6) CH-2: Ⓞ RV8/AU-84A(F-1)</p>

11-25. REC LEVEL ADJUSTMENT (CONVENTIONAL)

machine conditions for adjustment	spec.	adjustment
<ul style="list-style-type: none"> • AUDIO IN connector: 1kHz, - 60dBm • Play back the self recorded tape. 	<p>AUDIO OUT connector (terminated by 600Ω)</p> <p>+ 4 ± 0.3dBm</p>	<p>CH-1: Ⓞ RV9/AU-83A(C-6) CH-2: Ⓞ RV9/AU-84A(G-1)</p>

11-26. CH-1 INSERT CROSSTALK CANCEL ADJUSTMENT

machine conditions for adjustment	spec.	adjustment						
<ul style="list-style-type: none"> Extend the AU-84A Board by using the EX-127 Extension Board. AUDIO CH-1 IN connector: 500Hz/5kHz/15kHz, -60dBm Play back the no audio and video signals recorded tape. CH-1 INSERT mode 	<p>CH-2 AUDIO OUT connector (terminated by 600Ω)</p> <p>Minimize the level at the each frequency.</p> <table border="1"> <tr> <td>500Hz</td> <td>5kHz</td> <td>15kHz</td> </tr> <tr> <td>max - 25dBm</td> <td>max - 20dBm</td> <td>max + 3dBm</td> </tr> </table>	500Hz	5kHz	15kHz	max - 25dBm	max - 20dBm	max + 3dBm	<p>500Hz ⊗ RV1/AU-84A(B-2)</p> <p>5kHz ⊗ RV2/AU-84A(A-2)</p> <p>15kHz ⊗ LV2/AU-84A(A-3)</p>
500Hz	5kHz	15kHz						
max - 25dBm	max - 20dBm	max + 3dBm						

11-27. CH-2 INSERT CROSSTALK CANCEL ADJUSTMENT

machine conditions for adjustment	spec.	adjustment						
<ul style="list-style-type: none"> Extend the AU-83A Board by using the EX-127 Extension Board. AUDIO CH-2 IN connector: 500Hz/5kHz/15kHz, -60dBm Play back the no audio and video signals recorded tape. CH-2 INSERT mode 	<p>CH-1 AUDIO OUT connector (terminated by 600Ω)</p> <p>Minimize the level at the each frequency.</p> <table border="1"> <tr> <td>500Hz</td> <td>5kHz</td> <td>15kHz</td> </tr> <tr> <td>max - 25dBm</td> <td>max - 20dBm</td> <td>max + 3dBm</td> </tr> </table>	500Hz	5kHz	15kHz	max - 25dBm	max - 20dBm	max + 3dBm	<p>500Hz ⊗ RV1/AU-83A(G-5)</p> <p>5kHz ⊗ RV2/AU-83A(G-5)</p> <p>15kHz ⊗ LV2/AU-83A(G-4)</p>
500Hz	5kHz	15kHz						
max - 25dBm	max - 20dBm	max + 3dBm						

11-28. DOLBY DETECT INHIBIT ADJUSTMENT

machine conditions for adjustment	spec.	adjustment
<ul style="list-style-type: none"> Play back the pulse & bar (B/W) segment of the alignment tape RR5-1SD PAL PB mode 	<p>CH-1: TP25/AU-85A(B-4) CH-2: TP27/AU-85A(B-4)</p> <p>+4.5±0.2Vdc</p>	<p>⊗ CH-1: RV10/AU-85A(A-5) ⊗ CH-2: RV11/AU-85A(C-4)</p>

11-29. PILOT TONE REC LEVEL ADJUSTMENT

machine conditions for adjustment	spec.	adjustment
<ul style="list-style-type: none"> • Extend the AU-85A Board by using the EX-127 Extension Board. • No signal is supplied to the AUDIO IN connector. • DOLBY NR sw: ON • Play back the self recorded tape. 	<p>CH-1: TP15/AU-85A(E-6) CH-2: TP16/AU-85A(D-6)</p> <p style="text-align: center;">$0.6 \pm 0.05V$</p>	<ul style="list-style-type: none"> ⊗ CH-1: RV8/AU-85A(B-6) ⊗ CH-2: RV9/AU-85A(C-6) <p>REC mode → adj. PB mode → check</p>

11-30. PILOT TONE REC PHASE ADJUSTMENT

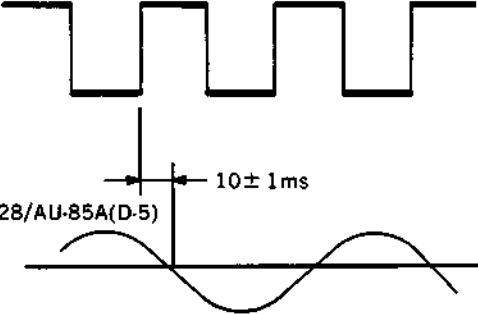
machine conditions for adjustment	spec.	adjustment
<ul style="list-style-type: none"> • Extend the AU-85A Board by using the EX-127 Extension Board. • No signal is supplied to the AUDIO IN connector. • DOLBY NR sw: ON • REC mode 	<p>CH-1; TP13/AU-85A(F-7)</p>  <p>CH-2; TP28/AU-85A(D-5)</p> <p style="text-align: center;">$10 \pm 1ms$</p>	<ul style="list-style-type: none"> ⊗ RV1/AU-85A(G-5)

11-31. INSERT 20kHz TRAP ADJUSTMENT

machine conditions for adjustment	spec.	adjustment
<ul style="list-style-type: none"> • Extend the AU-83A Board and the AU-84A Board by using the Extension Board. • AUDIO IN connector: 20kHz, - 80dBm • Play back the self recorded tape. 	<p>LINE OUT connector (terminated by 600Ω)</p> <p style="text-align: center;">Memorize the CH-1 level and CH-2 level. CH-1 level = A CH-2 level = B</p>	
<p>CH-1 adj.</p> <ul style="list-style-type: none"> • No signal is supplied to the AUDIO IN connector. • Play back the self recorded portion. • CH-2 INSERT mode 	<p>LINE OUT connector(CH-1) (terminated by 600Ω)</p> <p style="text-align: center;">Level of 20kHz = A - 8 ± 0.5dB</p>	<p>⊙ LV4/AU-83A(G-6)</p>
<p>CH-2 adj.</p> <ul style="list-style-type: none"> • No signal is supplied to the AUDIO IN connector. • Play back the self recorded portion. • CH-1 INSERT mode 	<p>LINE OUT connector (CH-2) (terminated by 600Ω)</p> <p style="text-align: center;">Level of 20kHz = B - 8 ± 0.5dB</p>	<p>⊙ LV4/AU-84A(A-1)</p>



SECTION 12 VIDEO SYSTEM ALIGNMENT

[Equipment Required]

- Dual Trace Oscilloscope
- NTSC Signal Generator
- Vectorscope
- DC Voltmeter
- Frequency Counter
- Video Sweep Generator
- Spectrum Analyzer
- Cassette Tape: KCA, KCS and KSP.
- Alignment Tape: RR5-1SD PAL (Part No. 8-960-036-81)—SP tape—

TIME	VIDEO	AUDIO	TIME CODE
5	color bars	—	—
3	Gated sweep (B/W)	1kHz, 0dB	—
3	Gated sweep (color)	10kHz, -10dB	—
3	Pulse & bar (MOD 10T and inverted 2T)	1kHz, -20dB (NR: OFF) 40kHz, -20dB (NR: OFF) 7kHz, -20dB (NR: OFF) 10kHz, -20dB (NR: OFF) 15kHz, -20dB (NR: OFF)	—
3	Monoscope (color)	1kHz, -20dB (NR: ON) 15kHz, -20dB (NR: ON)	—
3	Pseudo color bars	—	TIME CODE

RR5-3SB PAL (Parts No. 8-960-012-83)—conventional tape—

TIME	VIDEO	AUDIO	TIME CODE
5	color bars	3kHz, 0dB	1kHz
5	R-F sweep	—	—
5	Monoscope	1kHz, 0dB	—
2.5	Modulated 20T pulse	10kHz, -10dB	—

[Switch Setting]

Front Panel

- VIDEO LEVEL swAUTO
- INPUT SELECT swLINE

Connector Panel

- VIDEO IN 75Ω swON
- REF VIDEO IN 75Ω swON
- EXT TBC swOFF

Do not move these switches unless otherwise specified.

Extend by using the EX-128 Extension Board to adjust the DM-55 board.

Extend by using the EX-127 Extension Board to adjust the BC-11 board.

12-1. PB RF FREQUENCY RESPONSE ADJUSTMENT (1)

Before starting this adjustment, no cassette should be inserted to stop the head drum rotation, and the sweep signal is L-coupled to the video head using an inductor (approximately 100 μ H).

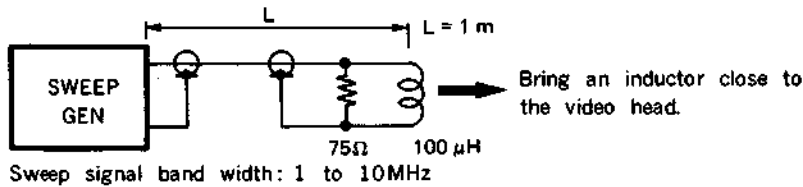

Step 1. CH-A RF frequency response adjustment

machine conditions for adjustment	spec.	adjustment				
<ul style="list-style-type: none"> • Short between CN104-10B/DM-55 (D-7) and GND; and CN604-3/MD-45 (G-8) and GND with shorting clips. • Adjust the sweep generator output so that the signal level is 250 mVp-p. • Couple the sweep signal to the video head (CH-A). • Adjust the coupling so that the amplitude is maximized. • After the adjustment is completed, remove the shorting clips. 	<p>TP7/PR-30A (D-2)</p> <table border="1" style="margin-left: auto; margin-right: auto;"> <tr> <td>2MHz</td> <td>8MHz</td> </tr> <tr> <td>100% (REF)</td> <td>130%</td> </tr> </table>	2MHz	8MHz	100% (REF)	130%	<p>RV4/RP-30A (D-2)</p> <p>TRIG: TRIG OUT of SWEEP GEN</p>
2MHz	8MHz					
100% (REF)	130%					

Step 2. CH-B RF frequency response adjustment

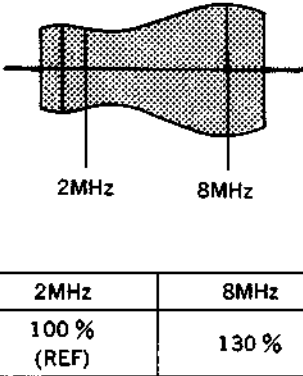
machine conditions for adjustment	spec.	adjustment				
<ul style="list-style-type: none"> • Short between CN104-10B/DM-55 (D-7) and GND; and CN604-3/MD-45 (G-8) and GND with shorting clips. • Adjust the sweep generator output so that the signal level is 250 mVp-p. • Couple the sweep signal to the video head (CH-B). • Adjust the coupling so that the amplitude is maximized. • After the adjustment is completed, remove the shorting clips. 	<p>TP10/RP-30A(D-1)</p>  <table border="1" data-bbox="667 965 1046 1070"> <tr> <td>2MHz</td> <td>8MHz</td> </tr> <tr> <td>100 % (REF)</td> <td>130 %</td> </tr> </table>	2MHz	8MHz	100 % (REF)	130 %	<p>RV6/RP-30A(D-1)</p> <p>TRIG : TRIG OUT of SWEEP GEN</p>
2MHz	8MHz					
100 % (REF)	130 %					

12-2. AUDIO BIAS TRAP ADJUSTMENT

machine conditions for adjustment	spec.	adjustment
<ul style="list-style-type: none"> • Insert the tape on which only a CTL signal is recorded (a video signal is not being recorded on the tape). • AUDIO CH-1 INSERT mode. 	<p>TP511/DM-55(L-6)</p> <p>Minimize bias leak A.</p> 	<p>LV501/DM-55(M-6)</p>

12-3. DROPOUT COMPENSATION SENSITIVITY ADJUSTMENT

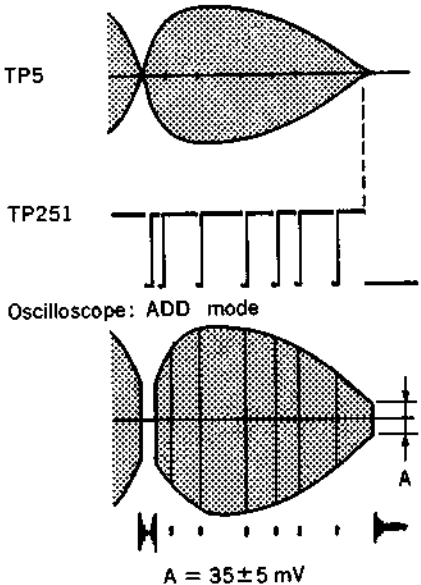
machine conditions for adjustment	spec.	adjustment
<ul style="list-style-type: none"> • Play back the RF sweep segment of the alignment tape RR5-3SB PAL. 	<p>CH-1: TP5/DM-55(R-3) CH-2: TP251/DM-55(Q-3)</p>  <p>Oscilloscope: ADD mode</p> <p>A = 35 ± 5 mV</p>	<p>RV251/DM-55(Q-3)</p>

12-4. RF AMPLIFIER DC BALANCE ADJUSTMENT

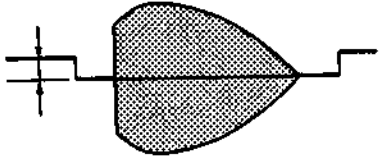
machine conditions for adjustment	spec.	adjustment
<ul style="list-style-type: none"> • Play back the RF sweep segment of the alignment tape RR5-3SB PAL • Fully turn RV1/DM-55 (Q-6) clockwise. (when viewed from component side) • S2O1/SV-88A(K-1): No.8 ON • S2O2/SV-88A(M-1): ON 	<p>TP17/DM-55(R-5)</p>  <p>Equalize the DC level in both channels.</p> <p>TRIG: TP4/DM-55(R-5)</p>	<p>RV1/DM-55(Q-6)</p>

12-5. Y RF OUTPUT BALANCE ADJUSTMENT

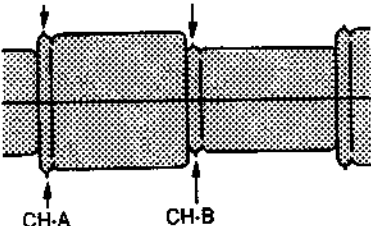
machine conditions for adjustment	spec.	adjustment
<ul style="list-style-type: none"> • Play back the color bars segment of the alignment tape RR5-3SB PAL. • Adjust the TRACKING control so that the RF level at TP5/DM-55(R-3) is maximized. 	<p>TP5/DM-55(R-3)</p>  <p>CH-A CH-B</p> <p>Sync tip level in CH-A = Sync tip level in CH-B(±5%)</p> <p>TRIG: TP4/DM-55(R-5)</p>	<p>RV17/DM-55(R-5)</p>

12-6. Y RF OUTPUT LEVEL ADJUSTMENT

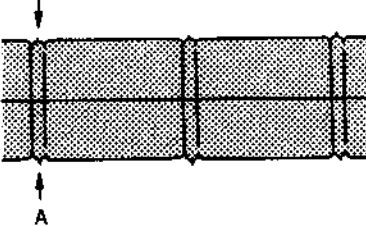
machine conditions for adjustment	spec.	adjustment
<ul style="list-style-type: none"> • Play back the color bars segment of the alignment tape RR5-3SB PAL. • Adjust the TRACKING control so that the RF level at TP5/DM-55(R-3) is maximized. 	<p>TP5/DM-55(R-3)</p>  <p>A</p> <p>$A = 0.32 \pm 0.04 \text{ V}_{pp}$</p> <p>TRIG : TP4/DM-55(R-5)</p>	<p>RV5/DM-85(Q-6)</p>

12-7. PB CHROMA RF BALANCE ADJUSTMENT

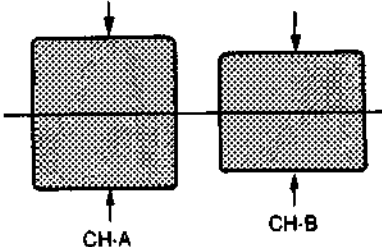
machine conditions for adjustment	spec.	adjustment
<ul style="list-style-type: none"> • Play back the color bars segment of the alignment tape RR5-3SB PAL • Adjust the TRACKING control so that the RF level at TP511/DM-55(L-6) is maximized. 	<p>TP511/DM-55(L-6)</p>  <p>CH-A level=CH-B level</p> <p>TRIG; TP4/DM-55(R-5)</p>	<p>RV4/DM-55(R-5)</p>

12-8. PB RF FREQUENCY RESPONSE ADJUSTMENT (2)

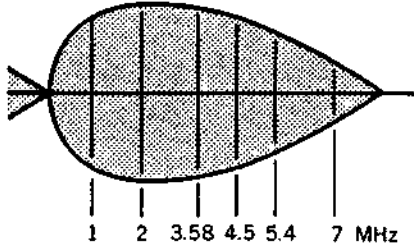
machine conditions for adjustment	spec.	adjustment										
<ul style="list-style-type: none"> • Play back the RF sweep segment of the alignment tape RR5-3SB PAL • Adjust the TRACKING control so that the RF level at TP5/DM-55(R-3) is maximized. • S201/SV-88A(K-1): No.8 ON • After the adjustment is completed, return the TRACKING control to the center click position. 	<p>TP5/DM-55(R-3)</p>  <table border="1" data-bbox="526 1534 1093 1646"> <thead> <tr> <th>2MHz</th> <th>3.58MHz</th> <th>4.5MHz</th> <th>5.4MHz</th> <th>7MHz</th> </tr> </thead> <tbody> <tr> <td>100% REF</td> <td>100 ±10%</td> <td>95 ±10%</td> <td>80 ±10%</td> <td>60 ±5%</td> </tr> </tbody> </table> <p>TRIG : TP4/DM-55(R-5)</p>	2MHz	3.58MHz	4.5MHz	5.4MHz	7MHz	100% REF	100 ±10%	95 ±10%	80 ±10%	60 ±5%	<p>CH-A: RV2/DM-55(Q-6) CH-B: RV3/DM-55(R-6)</p>
2MHz	3.58MHz	4.5MHz	5.4MHz	7MHz								
100% REF	100 ±10%	95 ±10%	80 ±10%	60 ±5%								

12-9. CARRIER BALANCE ADJUSTMENT

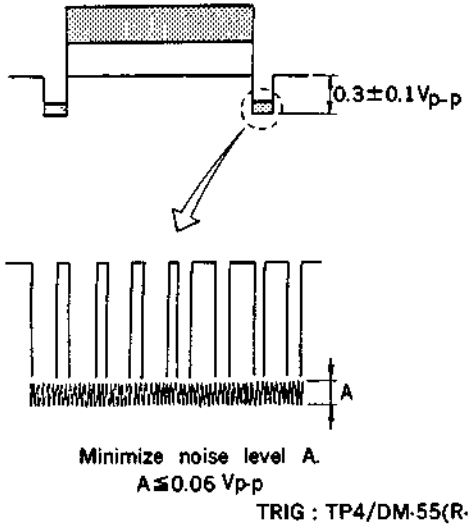
machine conditions for adjustment	spec.	adjustment
<ul style="list-style-type: none"> • Play back the color bars segment of the alignment tape RR5-3SB PAL 	<p>TP13/DM-55(M-3)</p>  <p>Minimize noise level A. $A \leq 0.06 V_{p-p}$ TRIG : TP4/DM-55(R-5)</p>	<ul style="list-style-type: none"> • RV8/DM-55(R-3)

12-10. SP MODE DETECTION ADJUSTMENT

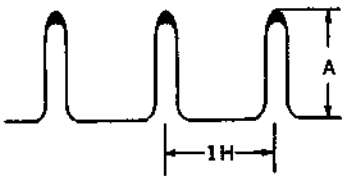
machine conditions for adjustment	spec.	adjustment
<ul style="list-style-type: none"> • S301/DM-55(F-1): ON • Play back the color-bar segment of the alignment tape RR5-3SB PAL • After the adjustment is completed, return S301 to the OFF. 	<p>TP301/DM-55(M-5) SPEC. 1</p>  <p>Maximum the A level</p> <p>SPEC. 2 $A = 2.3 \pm 0.5 V_{p-p}$ TRIG: TP509/DM-55(F-1)</p>	<p>SPEC. 1 • LV301/DM-55(N-5)</p> <p>SPEC. 2 • RV301/DM-55(M-5)</p>
<ul style="list-style-type: none"> • Play back the color-bar segment of the alignment tape RR5-1SD PAL 	<p>Confirm that the SP lamp on the Front Panel lights.</p>	

12-11. Y PHASE EQUALIZING PRE-ADJUSTMENT (SP MODE)

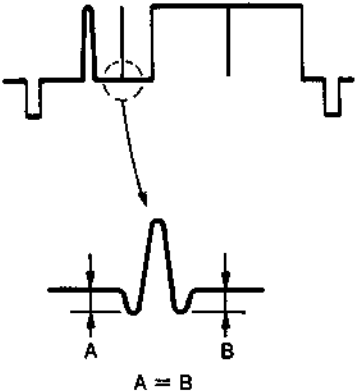
machine conditions for adjustment	spec.	adjustment
<ul style="list-style-type: none"> • Play back the pulse & bar segment of the alignment tape RR5-1SD PAL 	<p>TP15/DM-55(D-2)</p>  <p>A = B</p>	<ul style="list-style-type: none"> • LV1/DM-55(N-4)

12-12. Y PHASE EQUALIZING PRE-ADJUSTMENT (CONVENTIONAL MODE)

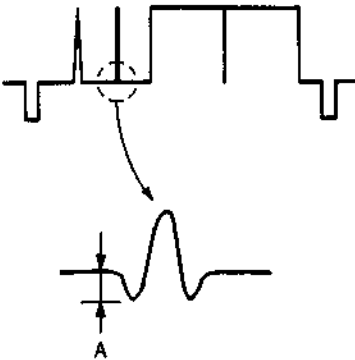
machine conditions for adjustment	spec.	adjustment
<ul style="list-style-type: none"> • Play back the MOD 20T pulse segment of the alignment tape RR5-3SB PAL. 	<p>TP15/DM-55(D-2)</p>  <p>Minimize A.</p>	<ul style="list-style-type: none"> • RV12/DM-55(M-2)

12-13. DUB Y PB FREQUENCY RESPONSE ADJUSTMENT (SP MODE)

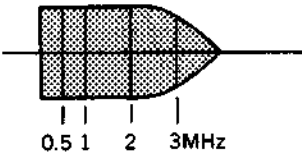
machine conditions for adjustment	spec.	adjustment								
<ul style="list-style-type: none"> • Play back the gated sweep (color) segment of the alignment tape RR5-1SD PAL 	<p>TP801/DM-55(K-5)</p>  <table border="1" data-bbox="624 864 1075 987"> <thead> <tr> <th>0.5MHz</th> <th>1MHz</th> <th>2MHz</th> <th>3MHz</th> </tr> </thead> <tbody> <tr> <td>100% (REF)</td> <td>100 ±5%</td> <td>100 ±5%</td> <td>90 ±5%</td> </tr> </tbody> </table>	0.5MHz	1MHz	2MHz	3MHz	100% (REF)	100 ±5%	100 ±5%	90 ±5%	<p>⊗ CV2/DM-55(M-3)</p>
0.5MHz	1MHz	2MHz	3MHz							
100% (REF)	100 ±5%	100 ±5%	90 ±5%							

NOTE: After the adjustment is completed, repeat Sec. 12-11. Y PHASE EQUALIZING ADJUSTMENT (SP MODE).

12-14. DUB Y PB FREQUENCY RESPONSE ADJUSTMENT (CONVENTIONAL MODE)

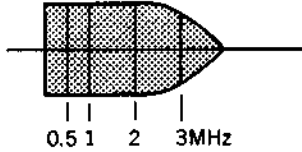
machine conditions for adjustment	spec.	adjustment								
<ul style="list-style-type: none"> • Insert a KCA or KCS cassette tape. • VIDEO IN connector: Gated sweep (color) • Play back the self-recorded portion. 	<p>TP801/DM-55(K-5)</p>  <table border="1" data-bbox="624 1630 1075 1731"> <thead> <tr> <th>0.5MHz</th> <th>1MHz</th> <th>2MHz</th> <th>3MHz</th> </tr> </thead> <tbody> <tr> <td>100% (REF)</td> <td>102 ±6%</td> <td>102 ±6%</td> <td>90 ±10%</td> </tr> </tbody> </table>	0.5MHz	1MHz	2MHz	3MHz	100% (REF)	102 ±6%	102 ±6%	90 ±10%	<p>⊗ CV1/DM-55(M-2)</p>
0.5MHz	1MHz	2MHz	3MHz							
100% (REF)	102 ±6%	102 ±6%	90 ±10%							

NOTE: After the adjustment is completed, repeat Sec. 12-12. Y PHASE EQUALIZING ADJUSTMENT (CONVENTIONAL MODE).

12-15. Y OUTPUT LEVEL ADJUSTMENT (SP MODE)

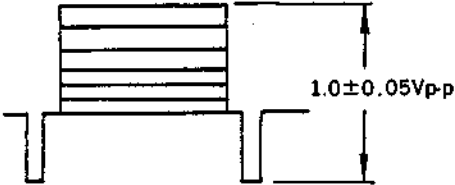
machine conditions for adjustment	spec.	adjustment
<p>• Play back the color bars segment of the alignment tape RR5-1SD PAL</p>	<p>TP15/DM-55(D-2)</p>  <p>NOTE: When noises appear at TP15/DM-55, read the level at the center of the noise.</p> <p>TRIG: TP4/DM-55(R-5)</p>	<p>RV11/DM-55(M-2)</p>

12-16. Y OUTPUT LEVEL ADJUSTMENT (CONVENTIONAL MODE)

machine conditions for adjustment	spec.	adjustment
<p>• Play back the color bars segment of the alignment tape RR5-3SB PAL</p>	<p>TP15/DM-55(D-2)</p>  <p>NOTE: When noises appear at TP15/DM-55, read the level at the center of the noise.</p> <p>TRIG: TP4/DM-55(R-5)</p>	<p>RV16/DM-55(M-1)</p>

12-17. DOC LEVEL ADJUSTMENT

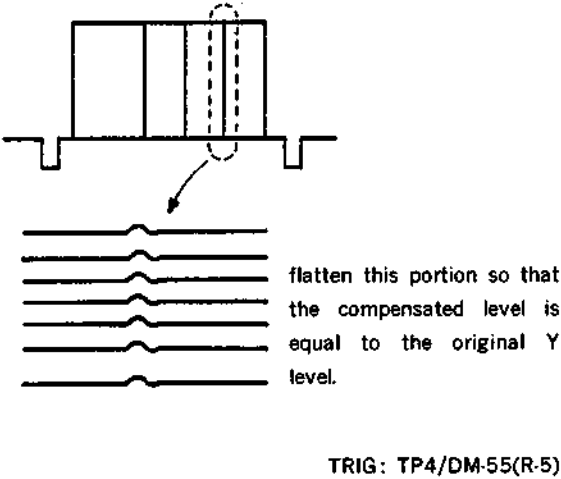
machine conditions for adjustment	spec.	adjustment
<ul style="list-style-type: none"> • Play back the pseudo color bars segment of the alignment tape RR5-1SD PAL 	<p>TP801/DM-54(K-5)</p>  <p>flatten this portion so that the compensated level is equal to the original Y level.</p> <p>TRIG: TP4/DM-55(R-5)</p>	<ul style="list-style-type: none"> ● RV13/DM-55(K-3) ● RV201/DM-55(K-2)

12-18. HORIZONTAL CORRELATOR BALANCE ADJUSTMENT

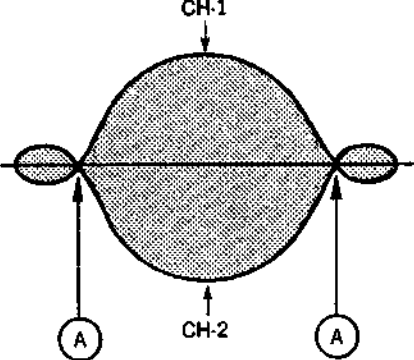
machine conditions for adjustment	spec.	adjustment
<ul style="list-style-type: none"> • VIDEO IN connector: Locked Sweep • EE mode • Oscilloscope CH-2: INV mode 	<p>CH-1/CH-2: TP12/MD-45(L-6) Oscilloscope: CHOP mode</p>  <p>Must be conformed to A point, adjust so that the waveform is symmetrical pattern.</p> <p>TRIG: TP4/DM-55(R-5)</p>	<ul style="list-style-type: none"> ● RV1/MD-45(L-6)

12-19. Y PHASE EQUALIZING ADJUSTMENT

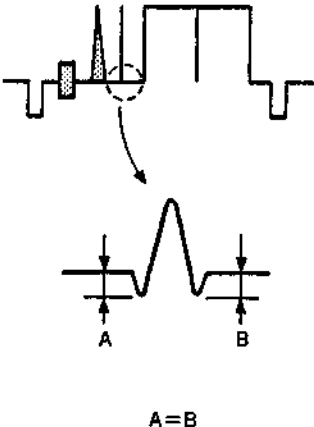
machine conditions for adjustment	spec.	adjustment
<ul style="list-style-type: none"> • VIDEO IN connector: MOD 10T • EE mode 	<p>TP101/MD-45(J-3)</p>  <p style="text-align: center;">A=B</p>	<p>RV6/MD-45(J-5)</p>

12-20. CHROMA DELAY ADJUSTMENT

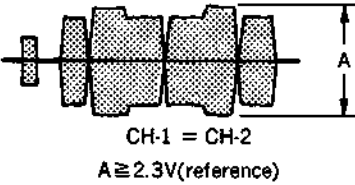
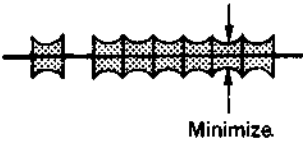
machine conditions for adjustment	spec.	adjustment
<ul style="list-style-type: none"> • VIDEO IN connector: PAL color bars • EE mode • Oscilloscope: CHOP mode 	<p>CH-1: TP14/MD-45(K-4) CH-2: TP15/MD-45(L-4)</p>  <p style="text-align: center;">CH-1 = CH-2 A ≅ 2.3V(reference)</p> <p style="text-align: center;">TRIG: TP11/MD-45(K-7)</p>	<p>RV3/MD-45(L-4)</p>
<ul style="list-style-type: none"> • VIDEO IN connector: PAL color bars • EE mode • Oscilloscope: ADD mode (CH-2: INVERT) 	 <p style="text-align: center;">Minimize</p> <p style="text-align: center;">TRIG: TP11/MD-45(K-7)</p>	<p>RV2/MD-45(L-5)</p>

12-21. MIX LEVEL ADJUSTMENT

Step 1.

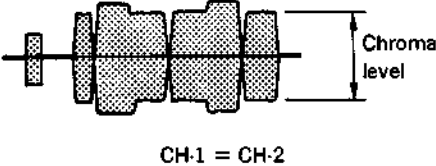
machine conditions for adjustment	spec.	adjustment
<ul style="list-style-type: none"> • VIDEO IN connector: PAL color bars • EE mode • Oscilloscope: CHOP mode 	<p>CH-1: TP12/MD-45(L-6) CH-2: TP18/MD-45(K-2)</p>  <p>CH-1 = CH-2</p> <p>TRIG: TP11/MD-45(K-7)</p>	<p>Chroma level adj. calibrator of Oscilloscope</p>

NOTE: When the center of the CH-1 waveform does not coincide with that of the CH-2, adjust in Step 2 first off.

Step 2.

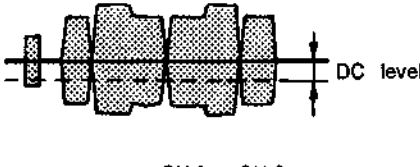
machine conditions for adjustment	spec.	adjustment
<ul style="list-style-type: none"> • VIDEO IN connector: PAL color bars • EE mode • Oscilloscope: CHOP mode 	<p>CH-1: TP12/MD-45(L-6) CH-2: TP18/MD-45(K-2)</p>  <p>CH-1 = CH-2</p> <p>TRIG: TP11/MD-45(K-7)</p>	<p>DC level adj. RV7/MD-45(L-2)</p>

12-22. SYNC TIP CARRIER FREQUENCY ADJUSTMENT (SP MODE)

machine conditions for adjustment	spec.	adjustment
<ul style="list-style-type: none"> • VIDEO IN connector: no signal • Insert a KSP cassette tape. • EE mode 	<p>TP207/MD-45(E-7)</p> <p>5.6±0.05MHz</p>	<p>RV202/MD-45(F-4)</p>

12-23. SYNC TIP CARRIER FREQUENCY ADJUSTMENT (CONVENTIONAL MODE)

machine conditions for adjustment	spec.	adjustment
<ul style="list-style-type: none"> • VIDEO IN connector: no signal • Insert a KCA or KCS cassette tape. • EE mode 	<p>TP207/MD-45(E-7)</p> <p>$4.8 \pm 0.05 \text{MHz}$</p>	<p>RV203/MD-45(F-4)</p>

12-24. FM DEVIATION ADJUSTMENT

machine conditions for adjustment	spec.	adjustment
<ul style="list-style-type: none"> • VIDEO IN connector: PAL color bars • EE mode 	<p>VIDEO OUT (terminated by 75 ohms.)</p>  <p>$A = 1.00 \pm 0.01 \text{V}_{p-p}$</p>	<p>RV101/MD-45(G-6)</p>

12-25. MODULATOR BALANCE ADJUSTMENT

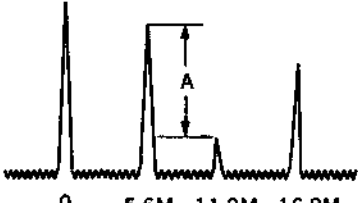
machine conditions for adjustment	spec.	adjustment
<ul style="list-style-type: none"> • VIDEO IN connector: no signal • Insert a KSP cassette tape. • EE mode • INPUT SELECT sw: DUB 	<p>TP204/MD-45(E-3)</p> <p>Spectrum analyzer</p>  <p>0 5.6M 11.2M 16.8M</p> <p>Minimize this 2nd component.</p> <p>$A \geq 45 \text{dB}$</p>	<p>RV201/MD-45(F-3)</p>

12-26. REC HF BALANCE ADJUSTMENT

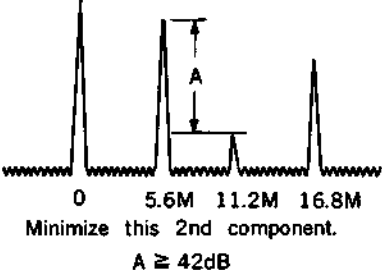
machine conditions for adjustment	spec.	adjustment
<ul style="list-style-type: none"> • VIDEO IN connector: no signal • Insert a KSP cassette tape. • EE mode • INPUT SELECT sw: DUB 	<p>TP207/MD-45(E-7) Spectrum analyzer</p>  <p>0 5.6M 11.2M 16.8M Minimize this 2nd component. $A \geq 42\text{dB}$</p>	<p>RV208/MD-45(E-4)</p>

12-27. WHITE CLIP ADJUSTMENT (SP MODE)

machine conditions for adjustment	spec.	adjustment
<ul style="list-style-type: none"> • VIDEO IN connector: pulse & bar • Insert a KSP cassette tape. • EE mode 	<p>TP205/MD-45(G-4)</p>  <p>When B is set as 100% reference, $A = 230 \pm 5\%$ TRIG: TP11/MD-45(K-7)</p>	<p>RV206/MD-45(F-5)</p>

12-28. WHITE CLIP ADJUSTMENT (CONVENTIONAL MODE)

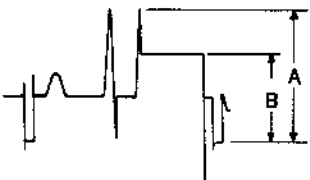
machine conditions for adjustment	spec.	adjustment
<ul style="list-style-type: none"> • VIDEO IN connector: pulse & bar • Insert a KCA or KCS cassette tape. • EE mode 	<p>TP205/MD-45(G-4)</p>  <p>When B is set as 100% reference, $A = 220 \pm 0\%$ TRIG: TP11/MD-45(K-7)</p>	<p>RV207/MD-45(F-6)</p>

12-29. DARK CLIP ADJUSTMENT (SP MODE)

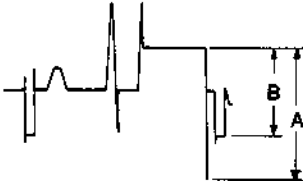
machine conditions for adjustment	spec.	adjustment
<ul style="list-style-type: none"> • VIDEO IN connector: pulse & bar • Insert a KSP cassette tape. • EE mode 	<p>TP205/MD-45(G-4)</p>  <p>When B is set as 100% reference, $A = 220 \pm 5\%$ TRIG: TP11/MD-45(K-7)</p>	<p>RV204/MD-45(F-4)</p>

12-30. DARK CLIP ADJUSTMENT (CONVENTIONAL MODE)

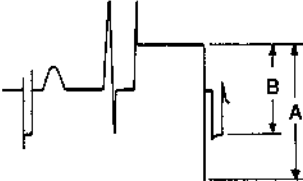
machine conditions for adjustment	spec.	adjustment
<ul style="list-style-type: none"> • VIDEO IN connector: pulse & bar • Insert a KCS or KCA cassette tape. • EE mode 	<p>TP205/MD-45(G-4)</p>  <p>When B is set as 100% reference, $A = 200 \pm 5\%$ TRIG: TP11/MD-45(K-7)</p>	<p>RV205/MD-45(F-5)</p>

12-31. SUB-CARRIER TRAP ADJUSTMENT

machine conditions for adjustment	spec.	adjustment
<ul style="list-style-type: none"> • Short between TP202/MD-45(G-3) and GND; and TP203/MD-45(F-3) and GND with shorting clips. • VIDEO IN connector: PAL color bars • EE mode • After the adjustment is completed, remove the shorting clips. 	<p>TP205/MD-45(G-4)</p>  <p>Minimize A. $(A \leq 40\text{mV}_{pp})$</p>	<p>LV201/MD-45(F-6)</p>

12-32. REC ACC ADJUSTMENT

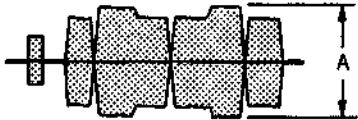
machine conditions for adjustment	spec.	adjustment
<ul style="list-style-type: none"> • VIDEO IN connector: PAL color bars • Insert a KSP cassette tape. • EE mode 	<p>TP509/MD-45(D-3)</p>  <p>$A = 0.8 \pm 0.05V$ TRIG: TP11/MD-45(K-7)</p>	<p>RV504/MD-45(C-4)</p>

12-33. APC DC ADJUSTMENT

machine conditions for adjustment	spec.	adjustment
<ul style="list-style-type: none"> • INPUT SELECT sw: DUB • EE mode • DC voltmeter 	<p>TP506/MD-45(C-5)</p> <p>$8.0 \pm 0.1V_{dc}$</p>	<p>RV505/MD-45(B-4)</p>

12-34. REC APC ADJUSTMENT

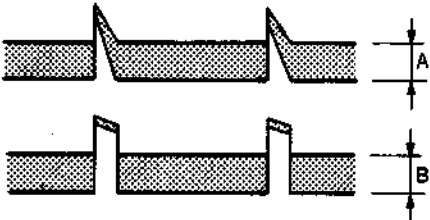
machine conditions for adjustment	spec.	adjustment
<ul style="list-style-type: none"> • VIDEO IN connector: PAL color bars • EE mode 	<p>TP506/MD-45(C-5)</p>  <p>$A = B$</p>	<p>T501/MD-45(A-3)</p>

NOTE: After the adjustment is completed, repeat Sec. 12-32. REC ACC ADJUSTMENT.

12-35. PILOT BURST ADJUSTMENT

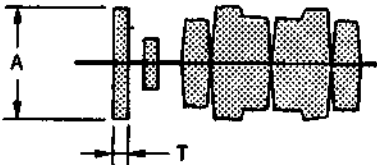
machine conditions for adjustment	spec.	adjustment
<ul style="list-style-type: none"> • VIDEO IN connector: PAL color bars • EE mode 	<p>TP508/MD-45(D-3)</p>  <p>$T = 3.5 \pm 0.1 \mu s$ $(A = 0.8 \pm 0.1 V)$</p> <p>TRIG: TP11/MD-45(K-7)</p>	<ul style="list-style-type: none"> • RV801/MD-45(G-2): T • RV802/MD-45(E-2): A

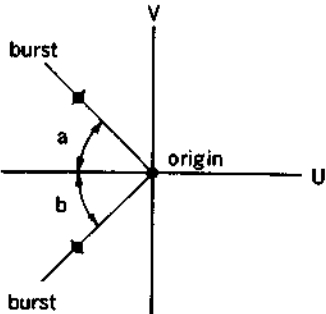

12-36. PILOT BURST PHASE ADJUSTMENT

machine conditions for adjustment	spec.	adjustment
<ul style="list-style-type: none"> • VIDEO IN connector: PAL color bars • EE mode • Vectorscope 	<p>TP508/MD-45(D-3)</p>  <p>$a = b = 45^\circ$</p> <p>TRIG: TP11/MD-45(K-7)</p>	<ul style="list-style-type: none"> • LV801/MD-45(F-2)

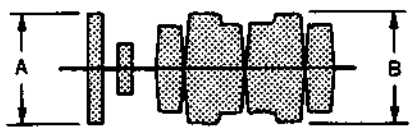
12-37. PILOT BURST LEVEL ADJUSTMENT

machine conditions for adjustment	spec.	adjustment
<ul style="list-style-type: none"> • VIDEO IN connector: PAL color bars • EE mode 	<p>TP508/MD-45(D-3)</p>  <p>$A = B$</p> <p>TRIG: TP11/MD-45(K-7)</p>	<ul style="list-style-type: none"> • RV802/MD-45(E-2)

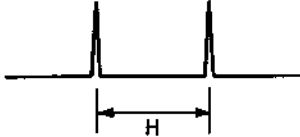
12-38. AFC PHASE ADJUSTMENT

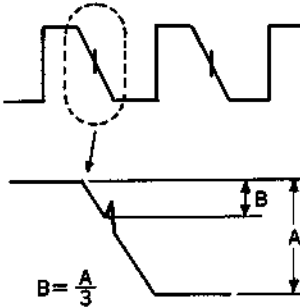
machine conditions for adjustment	spec.	adjustment
<ul style="list-style-type: none"> • VIDEO IN connector: PAL color bars • EE mode • Oscilloscope: ADD mode 	<p>CH-1: TP502/MD-45(C-5) CH-2: TP503/MD-45(C-6)</p> <p>TP502 </p> <p>TP503 </p> <p>ADD mode </p> <p style="text-align: center;">$B = \frac{A}{3}$</p>	<p>RV502/MD-45(B-7)</p>

12-39. 5.35MHz LEVEL ADJUSTMENT

machine conditions for adjustment	spec.	adjustment
<ul style="list-style-type: none"> • VIDEO IN connector: PAL color bars • EE mode 	<p>TP507/MD-45(D-4)</p> <p></p> <p style="text-align: right;">0.6Vp-p</p>	<p>RV503/MD-45(D-5)</p>

12-40. REC CHROMA RF LEVEL ADJUSTMENT

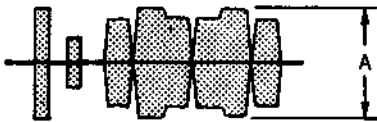
machine conditions for adjustment	spec.	adjustment
<ul style="list-style-type: none"> • VIDEO IN connector: PAL color bars • EE mode 	<p>TP501/MD-45(A-7)</p>  <p style="text-align: center;">$A = 0.5 \pm 0.025V_{p-p}$</p> <p style="text-align: right;">TRIG: TP11/MD-45(K-7)</p>	<p>RV501/MD-45(A-6)</p>

12-41. REF 135° BURST PULSE LEVEL ADJUSTMENT

machine conditions for adjustment	spec.	adjustment
<ul style="list-style-type: none"> • VIDEO IN connector: PAL color bars • EE mode 	<p>TP801/MD-45(D-8)</p>  <p style="text-align: center;">$A = 1.0 \pm 0.1V_{p-p}$</p> <p style="text-align: right;">TRIG: TP802/MD-45(C-8)</p>	<p>RV803/MD-45(D-7)</p>

12-42. PB CHROMA RF LEVEL ADJUSTMENT

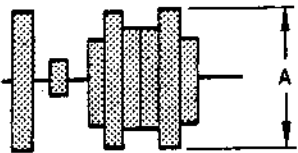
machine conditions for adjustment	spec.	adjustment
<ul style="list-style-type: none"> • Play back the color bars segment of the alignment tape RR5-1SD PAL • Adjust the TRACKING control so that the RF level at TP501/DM-55(A-7) is maximized. 	<p>TP501/DM-55(K-7)</p>  <p style="text-align: center;">$A = 0.2 \pm 0.01V$</p> <p style="text-align: right;">TRIG: TP509/DM-55(H-1)</p>	<p>RV501/DM-55(K-7)</p>

12-43. REFERENCE OSC ADJUSTMENT

machine conditions for adjustment	spec.	adjustment
<ul style="list-style-type: none"> • Play back the color bars segment of the alignment tape RR5-1SD PAL 	TP805/DM-55(E-5) $4433.619 \pm 0.005 \text{kHz}$	Ⓞ T501/DM-55(G-3)

12-44. VCO DC LEVEL ADJUSTMENT

machine conditions for adjustment	spec.	adjustment
<ul style="list-style-type: none"> • VIDEO IN connector: PAL color bars • EE mode • DC voltmeter 	TP514/DM-55(F-5) $8.4 \pm 0.1 \text{Vdc}$	Ⓞ RV505/DM-55(G-1)

12-45. 5.35MHz LEVEL ADJUSTMENT

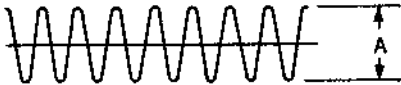
machine conditions for adjustment	spec.	adjustment
<ul style="list-style-type: none"> • EE mode 	TP513/DM-55(J-4)  $A = 0.6 \pm 0.03 \text{V}$	Ⓞ RV517/DM-55(J-3)

12-46. PB ACC BURST GATE ADJUSTMENT

Step 1. Burst flag level adjustment

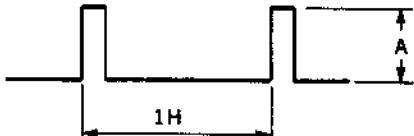
machine conditions for adjustment	spec.	adjustment
<ul style="list-style-type: none"> Play back the color bars segment of the alignment tape RR5-1SD PAL 	<p>TP509/DM-55(F-1)</p>  <p>$A = 4.5 \pm 0.1V$ TRIG: TP506/DM-55(F-1)</p>	<p>RV511/DM-55(E-1)</p>

Step 2. Burst flag width adjustment

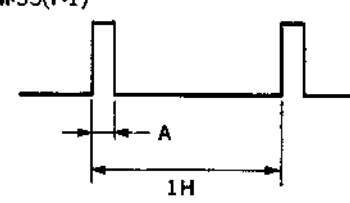
machine conditions for adjustment	spec.	adjustment
<ul style="list-style-type: none"> Play back the color bars segment of the alignment tape RR5-1SD PAL 	<p>TP509/DM-55(F-1)</p>  <p>$A = 2.2 \pm 0.1 \mu s$ TRIG: TP506/DM-55(F-1)</p>	<p>RV509/DM-55(E-1)</p>

Step 3. Burst flag phase adjustment

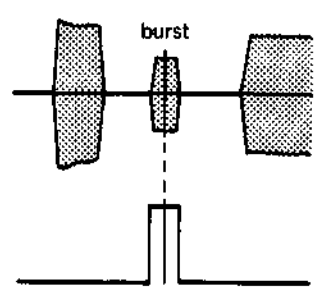
machine conditions for adjustment	spec.	adjustment
<ul style="list-style-type: none"> Play back the color bars segment of the alignment tape RR5-1SD PAL 	<p>TP802/DM-55(E-4)</p>  <p>Adjust the center of both waves. TRIG: TP506/DM-55(F-1)</p>	<p>RV508/DM-55(E-1)</p>

12-47. PB APC BURST GATE ADJUSTMENT

Step 1. Burst flag level adjustmest

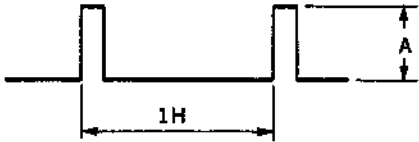
machine conditions for adjustment	spec.	adjustment
<ul style="list-style-type: none"> • Play back the color bars segment of the alignment tape RR5-1SD PAL 	<p>TP508/DM-55(F-1)</p>  <p>$A = 3.4 \pm 0.1V$</p> <p>TRIG: TP506/DM-55(F-1)</p>	<ul style="list-style-type: none"> • RV510/DM-55(D-1)

Step 2. Burst flag width adjustment

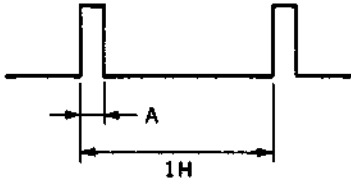
machine conditions for adjustment	spec.	adjustment
<ul style="list-style-type: none"> • Play back the color bars segment of the alignment tape RR5-1SD PAL 	<p>TP508/DM-55(F-1)</p>  <p>$A = 2.2 \pm 0.1 \mu s$</p> <p>TRIG: TP506/DM-55(F-1)</p>	<ul style="list-style-type: none"> • RV507/DM-55(D-2)

Step 3. Burst flag phase adjustment

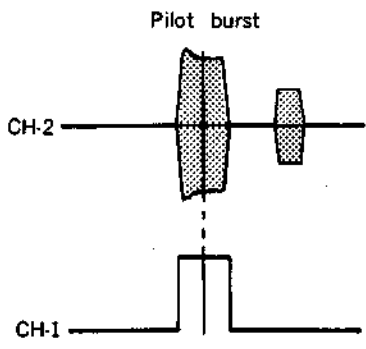
machine conditions for adjustment	spec.	adjustment
<ul style="list-style-type: none"> Play back the color bars segment of the alignment tape RR5-1SD PAL. 	<p>CH-1: TP508/DM-55(F-1) CH-2: TP802/DM-55(E-4)</p>  <p>Adjust the center of both waves.</p> <p>TRIG: TP506/DM-55(F-1)</p>	<p>RV804/DM-55(E-1)</p>

12-48. PB ACC LEVEL ADJUSTMENT

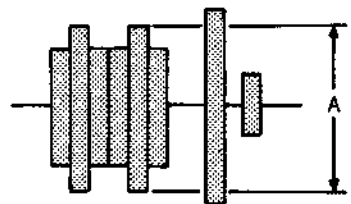
machine conditions for adjustment	spec.	adjustment
<ul style="list-style-type: none"> Play back the color bars segment of the alignment tape RR5-1SD PAL. 	<p>TP515/DM-55(G-5)</p>  <p>$A = 0.8 \pm 0.05V_{p-p}$</p> <p>TRIG: TP506/DM-55(F-1)</p>	<p>RV518/DM-55(G-3)</p>

12-49. DG COMPENSATOR PRE-ADJUSTMENT

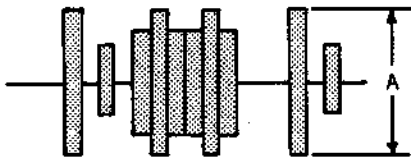
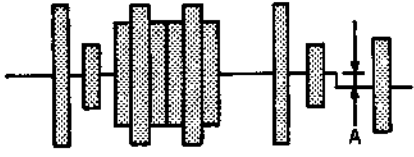
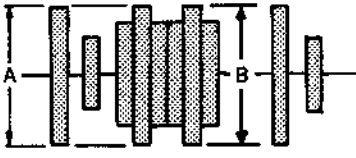
machine conditions for adjustment	spec.	adjustment
<ul style="list-style-type: none"> Fully turn RV514/DM-55(H-7) counterclockwise. Play back the color bars segment of the alignment tape RR5-1SD PAL 	<p>TP516/DM-55(G-5)</p>  <p>$A = 0.8 \pm 0.05V_{p-p}$</p> <p>TRIG: TP506/DM-55(F-1)</p>	<p>RV514/DM-55(H-7)</p>
<ul style="list-style-type: none"> Play back the color bars segment of the alignment tape RR5-1SD PAL 	<p>TP515/DM-55(G-5)</p>  <p>Equalize the DC level ($A = 0$).</p> <p>TRIG: TP506/DM-55(F-1)</p>	<p>RV516/DM-55(G-7)</p>
<ul style="list-style-type: none"> Fully turn RV513/DM-55(H-6) clockwise. Play back the color bars segment of the alignment tape RR5-1SD PAL 	<p>TP515/DM-55(G-5)</p>  <p>$A = B$</p> <p>TRIG: TP506/DM-55(F-1)</p>	<p>RV513/DM-55(H-6)</p>

12-50. CONVERTER BALANCE ADJUSTMENT

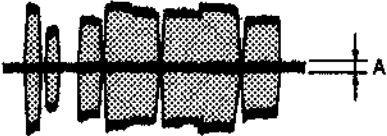
machine conditions for adjustment	spec.	adjustment
<ul style="list-style-type: none"> • Play back the color bars segment of the alignment tape RR5-1SD PAL • Wait for more than five minutes after power is turned on. 	<p>TP802/DM-55(E-4)</p>  <p>$A \leq 30\text{mV}$ Minimize the carrier leak.</p> <p>TRIG: TP506/DM-55(F-1)</p>	<p>RV519/DM-55 (G-6)</p>

12-51. DUB CHROMA LEVEL ADJUSTMENT

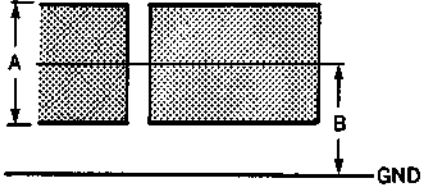
machine conditions for adjustment	spec.	adjustment
<ul style="list-style-type: none"> • Play back the color bars segment of the alignment tape RR5-1SD PAL 	<p>TP504/DM-55(C-6)</p>  <p>$A = 0.47 \pm 0.02\text{Vp-p}$ $B = 6.0 \pm 1.0\text{Vdc}$</p> <p>TRIG: TP4/DM-55(R-5)</p>	<p>RV504/DM-55(C-6)</p>

12-52. INVERT ED CHROMA INPUT LEVEL ADJUSTMENT

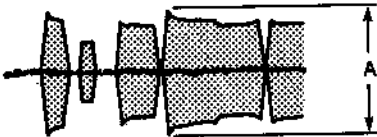
machine conditions for adjustment	spec.	adjustment
<p>• Play back the color bars segment of the alignment tape RR5-1SD PAL</p>	<p>TP802/DM-55(E-4)</p>  <p>$A = 0.5 \pm 0.05 V_{p-p}$</p> <p>TRIG: TP509/DM-55(F-1)</p>	<p>RV806/DM-55(E-5)</p>

12-53. PILOT BURST GATE PULSE ADJUSTMENT

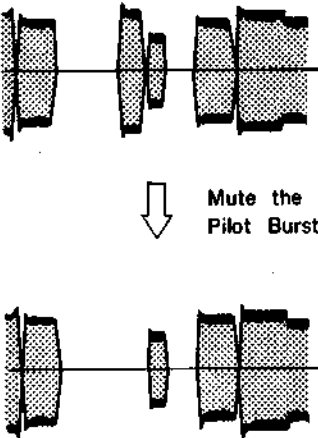
machine conditions for adjustment	spec.	adjustment
<p>• Play back the color bars segment of the alignment tape RR5-1SD PAL</p>	<p>TP803/DM-55(C-4)</p>  <p>TRIG: TP506/DM-55(F-1)</p>	<p>RV506/DM-55(D-1)</p>

12-54. PILOT BURST DC BALANCE ADJUSTMENT

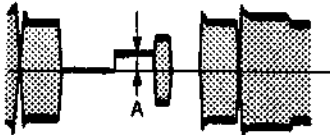
machine conditions for adjustment	spec.	adjustment
<ul style="list-style-type: none"> • Play back the color bars segment of the alignment tape RR5-1SD PAL 	<p>TP803/DM-55(C-4)</p>  <p>A = 0</p> <p>TRIG: TP506/DM-55(F-1)</p>	<ul style="list-style-type: none"> • RV805/DM-55(D-4)

12-55. HIGH SPEED ACC LEVEL ADJUSTMENT

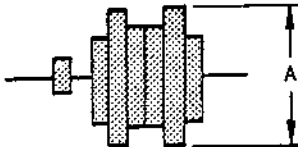
machine conditions for adjustment	spec.	adjustment
<ul style="list-style-type: none"> • Play back the color bars segment of the alignment tape RR5-1SD PAL 	<p>TP523/DM-55(E-3)</p>  <p>A = $0.45 \pm 0.02V_{p-p}$</p> <p>TRIG: TP506/DM-55(F-1)</p>	<ul style="list-style-type: none"> • RV522/DM-55(E-3)

12-56. HIGH SPEED ACC GAIN ADJUSTMENT

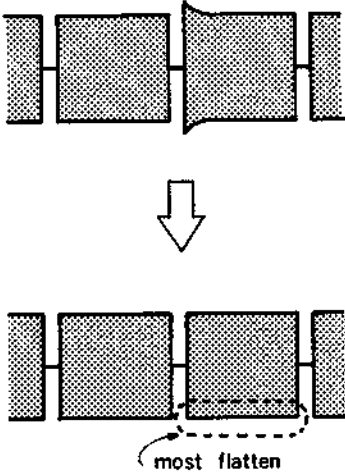
machine conditions for adjustment	spec.	adjustment
<ul style="list-style-type: none"> • Play back the color bars segment of the alignment tape RR5-1SD PAL. 	<p>TP523/DM-55(E-3)</p>  <p>TRIG: TP4/DM-55(R-5)</p>	<ul style="list-style-type: none"> • RV521/DM-55(D-4)

12-57. CHROMA NOISE CANCELLER ADJUSTMENT

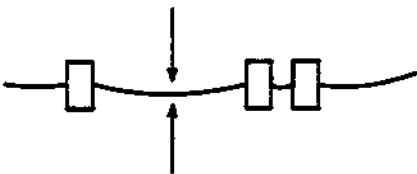
machine conditions for adjustment	spec.	adjustment
<ul style="list-style-type: none"> • Play back the color bars segment of the alignment tape RR5-1SD PAL 	<p>TP524/DM-55(D-2)</p>  <p>Minimize the amplitude.</p> <p>TRIG: TP509/DM-55(F-1)</p>	<ul style="list-style-type: none"> • RV523/DM-55(D-3)

12-58. TBC Y OUTPUT LEVEL ADJUSTMENT

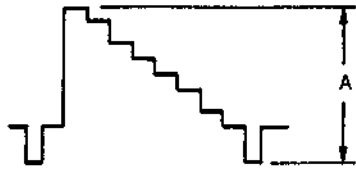
machine conditions for adjustment	spec.	adjustment
<ul style="list-style-type: none"> • Play back the color bars segment of the alignment tape RR5-1SD PAL. • Insert the TBC-6 board into the unit. 	<p>TP15/DM-55(D-2)</p>  <p>1.0±0.05Vp-p</p>	<p>RV15/DM-55(C-2)</p>

12-59. REC CURRENT FREQUENCY RESPONSE ADJUSTMENT

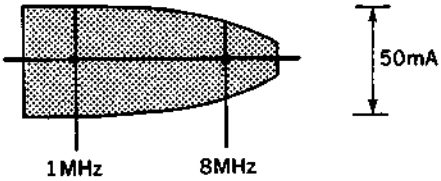
machine conditions for adjustment	spec.	adjustment										
<ul style="list-style-type: none"> • Desolder the bridge between TP5/RP-30A(D-2) and TP6/RP-30A(D-2). • Desolder the bridge between TB8/RP-30A(D-1) and TP9/RP-30A(D-1). • Short between TP3/RP-30A(B-2) and E2/RP-30A(B-2) with shorting clips. Connect between TP5(D-2) and TP6(D-2); and TP8(D-1) and TP9(D-1) on the RP-30A with shorting clips. • Supply an RF sweep signal to TP4/RP-30A(C-2). • Insert a KSP cassette tape. • VIDEO IN connector: PAL pulse & bars(B/W) • REC mode • After the adjustment is completed, remove the shorting clips and resolder the solder bridges. 	<p>CH-A: TP5/RP-30A(D-2) and TP6/RP-30A(D-2) CH-B: TP8/RP-30A(D-1) and TP9/RP-30A(D-1)</p>  <table border="1" data-bbox="523 1388 1088 1496"> <thead> <tr> <th>1 MHz</th> <th>4.43MHz</th> <th>7MHz</th> <th>8MHz</th> <th>10MHz</th> </tr> </thead> <tbody> <tr> <td>100% (REF)</td> <td>97 +3% -5%</td> <td>90 ±5%</td> <td>90 ±5%</td> <td>80 ±5%</td> </tr> </tbody> </table> <p>• Using a currentprobe, observe the current waveform.</p> <p>TRIG: VD/SWEEP GEN</p>	1 MHz	4.43MHz	7MHz	8MHz	10MHz	100% (REF)	97 +3% -5%	90 ±5%	90 ±5%	80 ±5%	<p>CH-A: RV3/RP-30A(C-2) CH-B: RV5/RP-30A(C-1)</p>
1 MHz	4.43MHz	7MHz	8MHz	10MHz								
100% (REF)	97 +3% -5%	90 ±5%	90 ±5%	80 ±5%								

12-60. Y REC CURRENT ADJUSTMENT

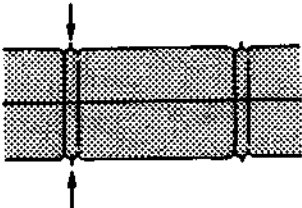
machine conditions for adjustment	spec.	adjustment
<ul style="list-style-type: none"> • Desolder the bridge between TP5/RP-30A(D-2) and TP6/RP-30A(D-2). • Connect between TP5/RP-30A and TP6/RP-30A with shorting clips. • Short between TP1/RP-30A(B-2) and GND with shorting clips. • VIDEO IN connector: PAL color bars <p>SP Mode Adjustment</p> <ul style="list-style-type: none"> • Insert a KSP cassette tape. • REC mode <p>Conventional Mode Adjustment</p> <ul style="list-style-type: none"> • Insert a KCA or KCS cassette tape. • REC mode • After the adjustment is completed, remove the shorting clips and resolder the solder bridge. 	<p>TP5/RP-30A(D-2) and TP6/RP-30A(D-2)</p>  <p>A(at sync)</p> <p>SP mode adjustment: $A=55\pm 5\text{mA}_{p-p}$ Conventional mode adjustment: $A=67\pm \frac{6}{5}\text{mA}_{p-p}$</p> <ul style="list-style-type: none"> • Using a currentprobe, observe the current waveform. <p>TRIG: TP101/MD-45(J-3)</p>	<p>SP mode adj. ⓄRV2/RP-30A(B-2) Conventional mode adj. ⓄRV209/MD-45(E-6)</p>

12-61. CHROMA REC CURRENT ADJUSTMENT

Step 1.

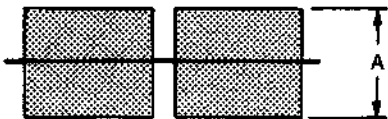
machine conditions for adjustment	spec.	adjustment
<ul style="list-style-type: none"> • Desolder the bridge between TP5/RP-30A(D-2) and TP6/RP-30A(D-2). • Connect between TP5/RP-30A and TP6/RP-30A with shorting clip. • Short between TP202/MD-45(G-3) and TP203/MD-45(F-3). • VIDEO IN connector: PAL color bars • Insert a KSP cassette tape. • REC mode • After the adjustment is completed, remove the shorting clips and resolder the solder bridge. 	<p>TP5/RP-30A(D-2) and TP6/RP-30A(D-2)</p>  <p style="text-align: center;">$A = 15 \pm 5 \text{mA}$</p> <ul style="list-style-type: none"> • Using a currentprobe, observe the current waveform. <p style="text-align: right;">TRIG: TP101/MD-45(J-3)</p>	<p>RV1/RP-30A(B-2)</p>

Step 2. (check procedure)

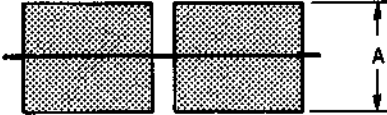
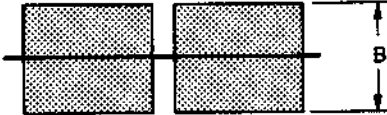
machine conditions for adjustment	spec.	adjustment
<ul style="list-style-type: none"> • Play back the color bars segment of the alignment tape RR5-1SD PAL • Adjust the TRACKING control so that the RF level at TP501/DM-55(K-7) is maximized. 	<p>TP501/DM-55(K-7)</p>  <p>Record the measured value at A.</p> <p>TRIG: TP4/DM-55(R-5)</p>	
<ul style="list-style-type: none"> • Set the TRACKING control to the center click position. • VIDEO IN connector: PAL color bars • Insert a KSP cassette tape and play back the self-recorded portion. 	<p>TP501/DM-55(K-7)</p>  <p>$B = A \pm 20\%$</p> <p>TRIG: TP4/DM-55(R-5)</p>	

NOTE: If the specification is not satisfied, readjust Step 1.

12-62. PB CHROMA FREQUENCY RESPONSE ADJUSTMENT

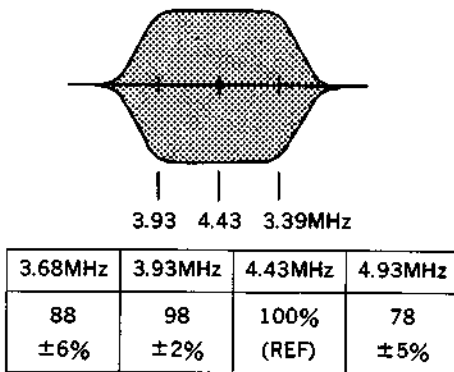
machine conditions for adjustment	spec.	adjustment								
<p>• Play back the gated sweep (color) segment of the alignment tape RR5-1SD PAL.</p>	<p>TP505/DM-55(D-2)</p>  <table border="1" data-bbox="574 795 1029 918"> <tr> <td>3.68MHz</td> <td>3.93MHz</td> <td>4.43MHz</td> <td>4.93MHz</td> </tr> <tr> <td>88 ±6%</td> <td>98 ±2%</td> <td>100% (REF)</td> <td>78 ±5%</td> </tr> </table>	3.68MHz	3.93MHz	4.43MHz	4.93MHz	88 ±6%	98 ±2%	100% (REF)	78 ±5%	<p>RV801/DM-55(L-7)</p>
3.68MHz	3.93MHz	4.43MHz	4.93MHz							
88 ±6%	98 ±2%	100% (REF)	78 ±5%							

12-63. PB Y/C DELAY ADJUSTMENT (SP MODE)

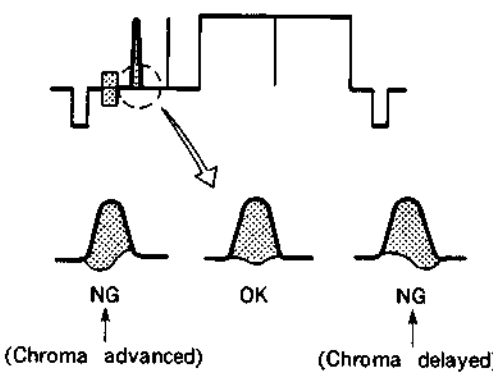
machine conditions for adjustment	spec.	adjustment
<p>• Play back the pulse & bar segment of the alignment tape RR5-1SD PAL.</p>	<p>VIDEO OUT 1 connector (terminated by 75 ohms.)</p> 	<p>RV802/DM-55(K-6)</p> <p>When the adjustment is not possible with RV802, adjust using DL802/DM-55(L-6) (at SP side) (When the chroma signal is advanced, adjust the tap to the higher number.)</p>

12-64. PB Y/C DELAY ADJUSTMENT(CONVENTIONAL MODE)

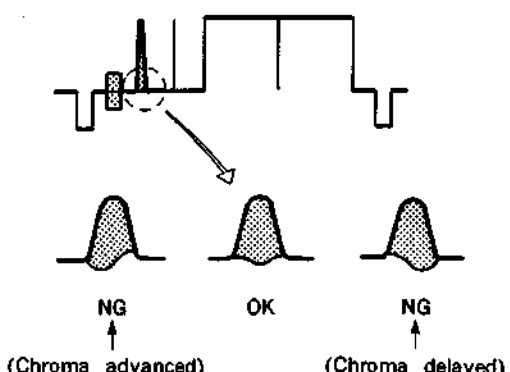
machine conditions for adjustment	spec.	adjustment
<p>• Play back the MOD 20T pulse segment of the alignment tape RR5-3SB PAL</p>	<p>VIDEO OUT 1 connector (terminated by 75 ohms.)</p> 	<p>● RV803/DM-55(J-6)</p> <p>When the adjustment is not possible with RV803, adjust using DL802/DM-55(L-6) (at conventional side) (When the chroma signal is advanced, adjust the tap to the higher number.)</p>

12-65. DUB Y/C DELAY ADJUSTMENT(SP MODE)

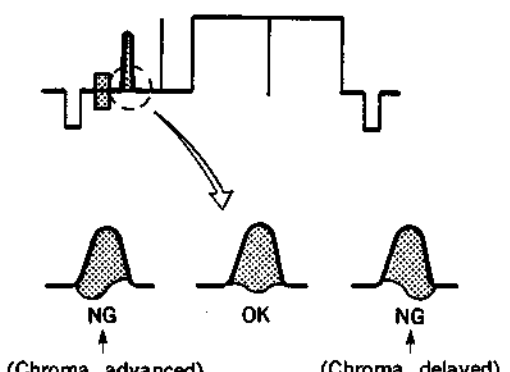
machine conditions for adjustment	spec.	adjustment
<p>• Play back the pulse & bar segment of the alignment tape RR5-1SD PAL</p>	<p>CH-1: TP801/DM-55(K-5) CH-2: TP504/DM-55(C-6) oscilloscope: ADD mode.</p> 	<p>● RV811/DM-55(E-7)</p>

12-66. REC Y/C DELAY ADJUSTMENT(SP MODE)

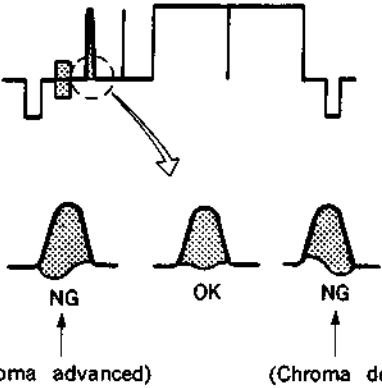
machine conditions for adjustment	spec.	adjustment																								
<ul style="list-style-type: none"> • VIDEO IN connector: MOD 10T pulse • Insert a KSP cassette tape and play back the self-recorded portion. 	<p>VIDEO OUT 1 connector (terminated by 75 ohms.)</p> 	<p>● DL501/MD-45(A-3)</p> <p>(When the chroma is advanced, adjust the tap to the higher number.)</p> <p>DL501(on soldering side)</p> <table border="0" style="margin-left: auto; margin-right: auto;"> <tr> <td>⊙</td> <td>● 6</td> <td>⊙</td> </tr> <tr> <td>⊙</td> <td>● 5</td> <td>⊙</td> </tr> <tr> <td>⊙</td> <td>● 4</td> <td>⊙</td> </tr> <tr> <td>⊙</td> <td>● 3</td> <td>⊙</td> </tr> <tr> <td>⊙</td> <td>● 2</td> <td>⊙</td> </tr> <tr> <td>⊙</td> <td>● 1</td> <td>⊙</td> </tr> <tr> <td>↑</td> <td></td> <td>↑</td> </tr> <tr> <td>Slits for SP</td> <td></td> <td>Slits for CONV</td> </tr> </table>	⊙	● 6	⊙	⊙	● 5	⊙	⊙	● 4	⊙	⊙	● 3	⊙	⊙	● 2	⊙	⊙	● 1	⊙	↑		↑	Slits for SP		Slits for CONV
⊙	● 6	⊙																								
⊙	● 5	⊙																								
⊙	● 4	⊙																								
⊙	● 3	⊙																								
⊙	● 2	⊙																								
⊙	● 1	⊙																								
↑		↑																								
Slits for SP		Slits for CONV																								

12-67. EE MODE Y/C DELAY ADJUSTMENT(SP MODE)

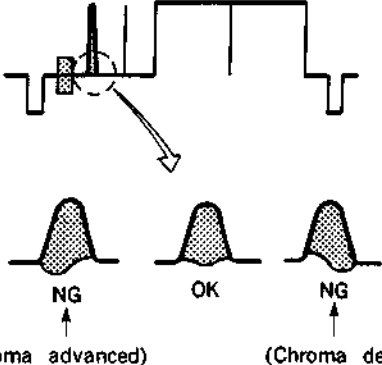
machine conditions for adjustment	spec.	adjustment
<ul style="list-style-type: none"> • VIDEO IN connector: MOD 10T pulse • Insert a KSP cassette tape. • EE mode 	<p>VIDEO OUT 1 connector (terminated by 75 ohms.)</p> 	<p>● RV809/DM-55(M-7)</p>

12-68. COLOR MODE Y OUTPUT LEVEL ADJUSTMENT

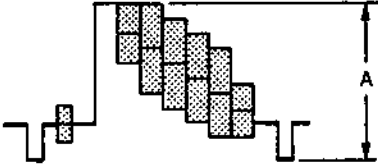
machine conditions for adjustment	spec.	adjustment
<ul style="list-style-type: none"> • VIDEO IN connector: PAL color bars • Insert a KSP cassette tape. • EE mode 	<p>VIDEO OUT 1 connector (terminated by 75 ohms.)</p>  <p style="text-align: center;">$A = 1.0 \pm 0.1V_{p-p}$</p>	<p>RV402/DM-55(C-3)</p>

12-69. Y/C MIX ADJUSTMENT

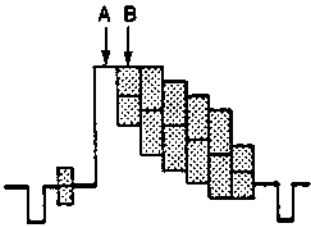
machine conditions for adjustment	spec.	adjustment
<ul style="list-style-type: none"> • VIDEO IN connector: PAL color bars • Insert a KSP cassette tape and play back the self-recorded portion. 	<p>VIDEO OUT 1 connector (terminated by 75 ohms.)</p>  <p style="text-align: center;">Equalize the level at A and B</p> <p style="text-align: center;">TRIG: TP506/DM-55(F-1)</p>	<p>RV401/DM-55(C-3)</p>

12-70. TIME CODE GATE PULSE LEVEL ADJUSTMENT

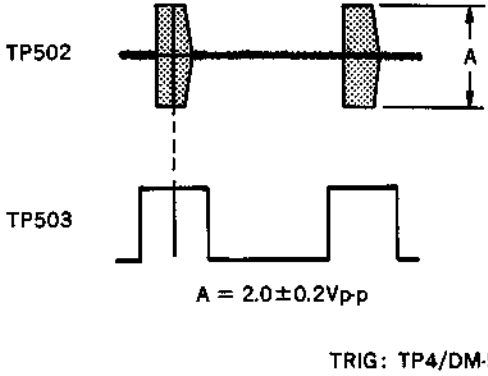
machine conditions for adjustment	spec.	adjustment
<ul style="list-style-type: none"> • Play back the color bars segment of the alignment tape RR5-3SB PAL. • Fully turn RV503/DM-55(K-7) counterclockwise. 	<p>CH-1: TP502/DM-55(K-7) CH-2: TP503/DM-55(J-7)</p>  <p>$A = 2.0 \pm 0.2V_{pp}$</p> <p>TRIG: TP4/DM-55(R-5)</p>	<p>RV503/DM-55(K-7)</p>

12-71. ROTARY ERASE CURRENT ADJUSTMENT

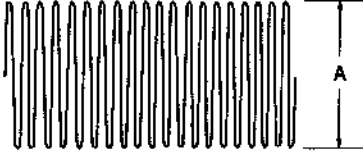
machine conditions for adjustment	spec.	adjustment
<ul style="list-style-type: none"> • VIDEO IN connector: PAL color bars • VIDEO INSERT mode 	<p>CH-A: TP102/RP-30A(A-2) CH-B: TP103/RP-30A(A-1)</p>  <p>$A = 1.0 \pm 0.05V$</p>	<p>CH-A: RV102/RP-30A(A-2) CH-B: RV101/RP-30A(A-2)</p>

12-72. NOISE CANCELLER ADJUSTMENT

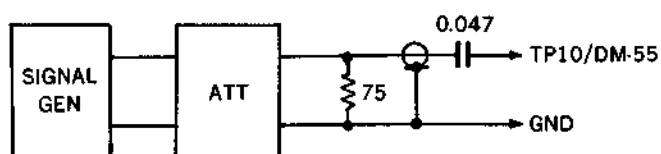

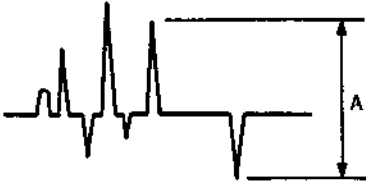
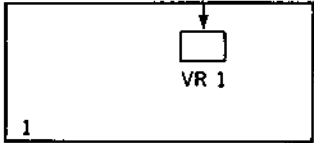
machine conditions for adjustment	spec.	adjustment
<ul style="list-style-type: none"> • Desolder the bridge at SL1/DM-55(B-1). • Connect a signal generator. • Output an MOD 20T pulse signal from the signal generator. <ul style="list-style-type: none"> • After the adjustment is completed, resolder the solder bridge. 	<p>TP10/DM-55(A-1)</p>  <p style="text-align: center;">$A = 100 \pm 5 \text{ mV}$</p>	<ul style="list-style-type: none"> • Attenuator
	<p>TP11/DM-55(B-2)</p>  <p style="text-align: center;">$A = 360 \pm 10 \text{ mV}$</p>	<ul style="list-style-type: none"> • VR1(IC12)/DM-55(B-2) 

12-73. Y PHASE EQUALIZING ADJUSTMENT(SP MODE)

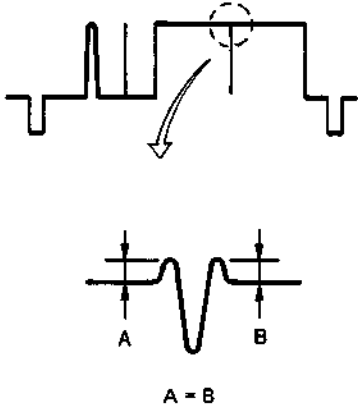
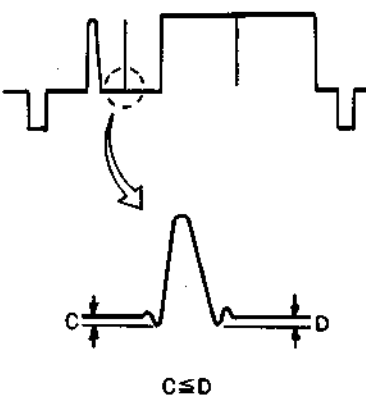
machine conditions for adjustment	spec.	adjustment
<ul style="list-style-type: none"> • Short between TP501/DM-55(K-7) and GND with shorting clip. • Play back the MOD 10T segment of the alignment tape RR5-1SD PAL 	<p>Step 1 VIDEO OUT 1 connector (terminated by 75 ohms.)</p>  <p>A = B</p> <p>TRIG: TP509/DM-55(F-1)</p>	<p>● LV1/DM-55(N-4)</p>
<ul style="list-style-type: none"> • After the adjustment is completed, remove the shorting clip. 	<p>Step 2 If the specification is not satisfied in Step 1, adjust Step 2.</p>  <p>C ≦ D</p>	<p>● RV810/DM-55(R-6)</p>

12-74. Y PHASE EQUALIZING ADJUSTMENT(CONVENTIONAL MODE)

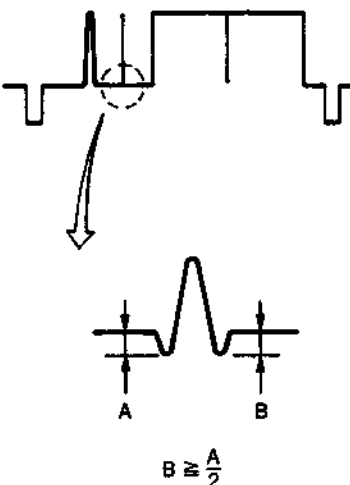
machine conditions for adjustment	spec.	adjustment
<ul style="list-style-type: none"> • Short between TP501/DM-55(K-7) and GND with shorting clip. • Play back the MOD 20T segment of the alignment tape RR5-3SB PAL • After the adjustment is completed, remove the shorting clip. 	<p>VIDEO OUT 1 connector (terminated by 75 ohms.)</p>  <p style="text-align: center;">$B \approx \frac{A}{2}$</p>	<p>RV12/DM-55(M-2)</p>

12-75. SP-CONV DC LEVEL DIFFERENCE ADJUSTMENT

machine conditions for adjustment	spec.	adjustment
<ul style="list-style-type: none"> • INPUT SELECT sw: DUB • Play back the color bars segment of the alignment tape RR5-3SB PAL • Record DC level "A" at TP8/DM-55(P-1). • Play back the color bars segment of the alignment tape RR5-1SD PAL • Read the DC level "B" at TP8/PM-55. 	<p>TP8/DM-55(P-1)</p> <p style="text-align: center;">B = A (adjust B level)</p>	<p>RV9/DM-55(R-1)</p>
<ul style="list-style-type: none"> • Play back the color bars segment of the alignment tape RR5-1SD PAL • Record DC level "C" at TP13/DM-55(N-4). • Play back the color bars segment of the alignment tape RR5-3SB PAL • Read the DC level "D" at TP13/DM-55. 	<p>TP13/DM-55(N-4)</p> <p style="text-align: center;">D = C (adjust D level)</p>	<p>RV10/DM-55(R-2)</p>

12-76. SLICE LEVEL ADJUSTMENT (1)

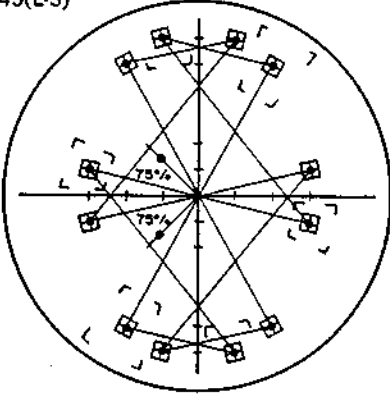
machine conditions for adjustment	spec.	adjustment
<ul style="list-style-type: none"> • VIDEO IN connector: PAL color bars • EE mode • Using a vectorscope's PHASE control and GAIN control, set the burst level to 75 % marked position. 	<p>TP17/MD-45(L-3)</p>  <ul style="list-style-type: none"> • Set the burst level to 75 %. • Set each spot to "田". 	<p>RV5/MD-45(L-3)</p>

12-77. SLICE LEVEL ADJUSTMENT (2)

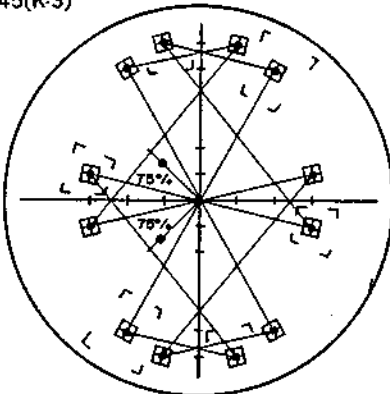
machine conditions for adjustment	spec.	adjustment
<ul style="list-style-type: none"> • VIDEO IN connector: PAL color bars • EE mode • Using a vectorscope's PHASE control and GAIN control, set the burst level to 75 % marked position. 	<p>TP16/MD-45(K-3)</p>  <ul style="list-style-type: none"> • Set the burst level to 75 %. • Set each spot to "田". 	<p>RV4/MD-45(K-3)</p>

12-78. TBC MODE APC ADJUSTMENT

Step 1.

machine conditions for adjustment	spec.	adjustment
<ul style="list-style-type: none"> • EXT TBC sw: ON • Play back the color bars segment of the alignment tape RR5-1SD PAL • DC voltmeter 	<p>TP514/DM-55(F-5)</p> <p style="text-align: center;">$8.4 \pm 0.1Vdc$</p>	<p>⊗ RV505/DM-55(G-1)</p>

Step 2.

machine conditions for adjustment	spec.	adjustment
<ul style="list-style-type: none"> • EXT TBC sw: ON • Play back the color bars segment of the alignment tape RR5-1SD PAL • Put the unit into the SEARCH mode and change the mode from FWD SEARCH X1/30 to STILL • DC voltmeter 	<p>TP514/DM-55(F-5)</p> <p style="text-align: center;">$9.15 \pm 0.05Vdc$</p>	<p>⊗ RV807/DM-55(E-2)</p>

Step 3.

machine conditions for adjustment	spec.	adjustment
<ul style="list-style-type: none"> • EXT TBC sw: ON • Play back the color bars segment of the alignment tape RR5-1SD PAL • Put the unit into the SEARCH mode and change the mode from REV SEARCH X1/30 to STILL • DC voltmeter 	<p>TP514/DM-55(F-5)</p> <p style="text-align: center;">$7.8 \pm 0.05Vdc$</p>	<p>⊗ RV808/DM-55(E-2)</p>

12-79. TIME CODE OUTPUT LEVEL ADJUSTMENT

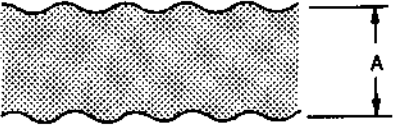
machine conditions for adjustment	spec.	adjustment
<ul style="list-style-type: none"> • Play back the pseudo color bars segment of the alignment tape RR5-1SD PAL. 	<p>TP102/BC-11(B-1) GND: E201/BC-11(C-4)</p>  <p>$A = 1.4 \pm 0.1V_{p-p}$</p>	<p>RV101/BC-11(B-6)</p>

12-80. TIME CODE REC CURRENT ADJUSTMENT

machine conditions for adjustment	spec.	adjustment
<ul style="list-style-type: none"> • VIDEO IN connector: PAL color bars • TIME CODE IN connector: 1.2 kHz, 1V_{p-p} square wave • Play back the self-recorded tape. 	<p>TP102/BC-11(B-1)</p>  <p>$A = 1.4 \pm 0.1V$</p> <p>Adjust in REC mode and check the level in PB mode.</p>	<p>RV102/BC-11(B-2)</p>

12-81. DG COMPENSATION ADJUSTMENT (SP MODE)

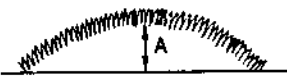
machine conditions for adjustment	spec.	adjustment
<ul style="list-style-type: none"> • VIDEO IN connector: MOD 5-step • Insert a KSP cassette tape and play back the self-recorded portion. • Calibrate the vectorscope's GAIN control so that the luminescent of vectorspot is located on the circumference. 	<p>VIDEO OUT</p> <p>Vectorscope</p>  <p>Minimize A. $DG \leq 3\%$</p>	<p>RV513/DM-55(H-6)</p>

12-82. VIDEO METER ADJUSTMENT

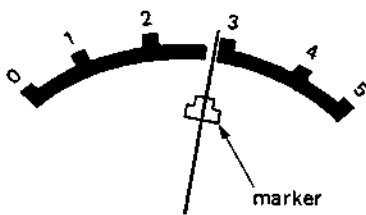
machine conditions for adjustment	spec.	adjustment
<ul style="list-style-type: none"> • VIDEO IN connector: PAL color bars • EE mode • Wait for more than five minutes after power is turned on. 	<p>Video meter</p>  <p>Adjust the pointer so that it reads the left of scale 3.</p>	<p>● RV302/MD-45(F-7)</p>

12-83. TRACKING METER ADJUSTMENT

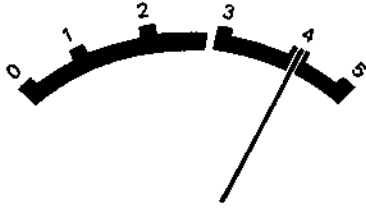
machine conditions for adjustment	spec.	adjustment
<ul style="list-style-type: none"> • Set the TRACKING control to the center click position. • VIDEO IN connector: PAL color bars • Insert a KSP cassette tape and play back the self-recorded portion. • Wait for more than five minutes after power is turned on. 	<p>Video/RF meter</p>  <p>Adjust the pointer so that it reads scale 4.</p>	<p>● RV301/MD-45(F-7)</p>

12-84. PB CHARACTER MIX ADJUSTMENT

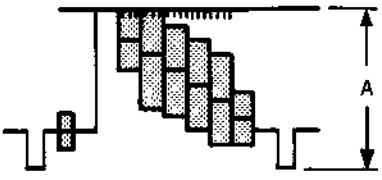
machine conditions for adjustment	spec.	adjustment
<ul style="list-style-type: none"> • VIDEO IN connector: Color-bar • Indicate the ITEM No.104, TITLE (LARGE) in the DIAL MENU operation on the monitor (Refer to Section 1-6.) • Select the ■ in the character menu area and set it one line in the title setup area. • Superimpose the title on the monitor. 	<p>TP404/DM-55(B-7)</p>  <p>A: Adjust the character signal portion to the white level.</p>	<p>RV403/DM-55(B-4)</p>

12-85. REC CHARACTER MIX ADJUSTMENT

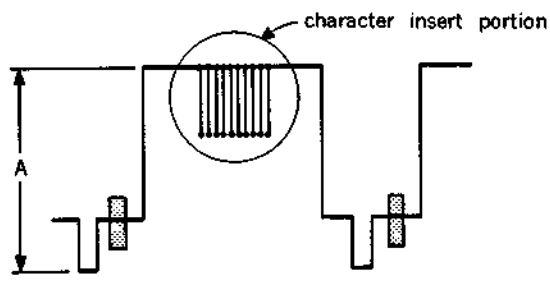
machine conditions for adjustment	spec.	adjustment
<ul style="list-style-type: none"> • VIDEO IN connector: 100% WHITE • Indicate the ITEM No.104, TITLE (LARGE) in the DIAL MENU operation on the monitor. (Refer to Section 1-6.) • Select the ■ in the character menu area and set it one line in the title setup area. • Superimpose the title on the monitor. • Set the CTL/TC/DIAL MENU switch to CTL 	<p>TP201/MD-45(G-5)</p>  <p>1. Adjust the high level portion of the character signal to the white portion of the video signal.</p> <p>2. Adjust so that same position when the REF VIDEO IN 75Ω switch on the connector panel is set to ON or OFF.</p>	<p>RV8/MD-45(L-7) RV9/MD-45(K-7)</p>

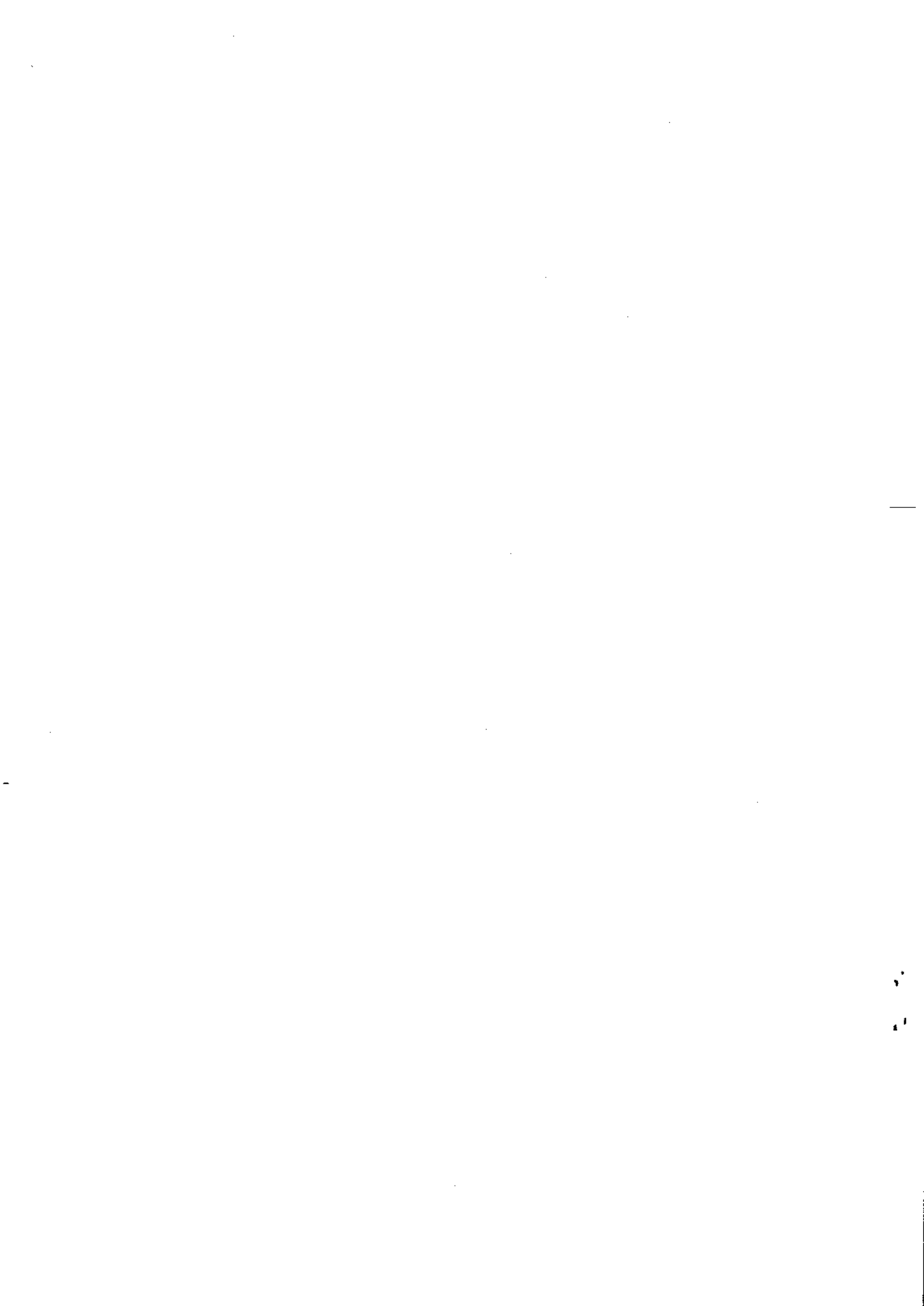

SECTION 13

TIME CODE SYSTEM ALIGNMENT AND OTHERS

[Equipment Required]

- Dual Trace Oscilloscope
- Square Wave Oscillator
- KSP or KSP-S Blank Tape (Blank Tape is no signal recorded Tape)
- Alignment Tape: RR5-1SD PAL (Part No. 8-960-036-81) -SP tape

TIME	VIDEO	AUDIO	TIME CODE
5	color bars	—	—
3	Gated sweep (B/W)	1kHz, 0dB	—
3	Gated sweep (color)	10kHz, -10dB	—
3	Pulse & bar (MOD 10T and inverted 2T)	1kHz, -20dB (NR: OFF) 40Hz, -20dB (NR: OFF) 7kHz, -20dB (NR: OFF) 10kHz, -20dB (NR: OFF) 15kHz, -20dB (NR: OFF)	—
3	Monoscope (color)	1kHz, -20dB (NR: ON) 15 kHz, -20dB (NR: ON)	—
3	Pseudo color bars	—	TIME CODE

[Switch/VR Setting]

Subcontrol Panel

- EXT/INT SELECT swEXT
- SLAVE LOCK/PRESET SELECT sw.....PRESET

13-1. TC PB LEVEL ADJUSTMENT

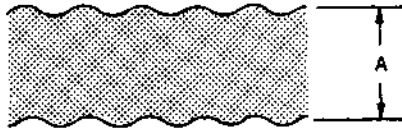
machine conditions for adjustment	spec.	adjustment
<ul style="list-style-type: none"> • Play back the time code signal on alignment tape RR-5-1SD PAL 	<p>TP102/BC-11(B-1) GND: E201/BC-11(C-4)</p>  <p style="text-align: center;">$A = 1.4 \pm 0.1V_{p-p}$</p> <p style="text-align: right;">TRIG: TP4/DM-55(R-5)</p>	<p>RV101/BC-11(B-6)</p>

13-2. TC REC LEVEL ADJUSTMENT

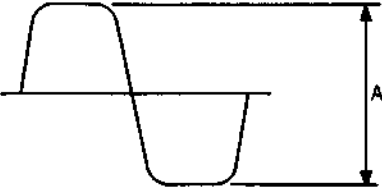
machine conditions for adjustment	spec.	adjustment
<ul style="list-style-type: none"> • Extend the BC-11 Board by using the EX-127 Extension Board. • TIME CODE IN connector: 1.2 kHz, square wave, 1 Vpp • VIDEO IN connector: video signal • Play back the self recorded tape. 	<p>TP102/BC-11(B-1)</p>  <p style="text-align: center;">$A = 1.4 \pm 0.1 \text{ Vpp}$</p>	<p>RV102/BC-11(B-2)</p> <p>REC mode → adj PB mode → check</p>

13-3. CHARACTER SIZE ADJUSTMENT

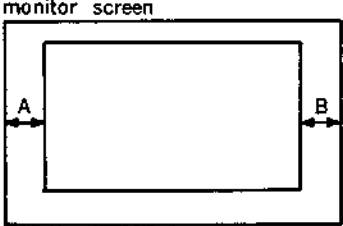
machine conditions for adjustment	spec.	adjustment
<ul style="list-style-type: none"> • Indicate the ITEM No.104, TITLE (LARGE) in the Dial Menu Operation on the screen. (Refer to Section 1-6) • Extend the DSC-44 Board by using the EX-127 Extension Board. • VIDEO IN connector: PAL Color-bar • EE mode 	<p>Balance the characters</p>  <p style="text-align: center;">$A \approx B$</p>	<p>CV1/DSC-44(B-2)</p>

13-4. CHARACTER POSITION ADJUSTMENT

machine conditions for adjustment	spec.	adjustment
<ul style="list-style-type: none">• Extend the DSC-44 Board by using the EX-127 Extension Board. • Set the title by the ITEM No. 104, TITLE (LARGE) in the Dial Menu Operation and record the title for 30 sec. • Play back the self recorded tape.	Clear the shifted characters.	●RV1/DSC-44(C-1)

