

BM-246

SERVICE MANUAL

AEP Model
UK Model

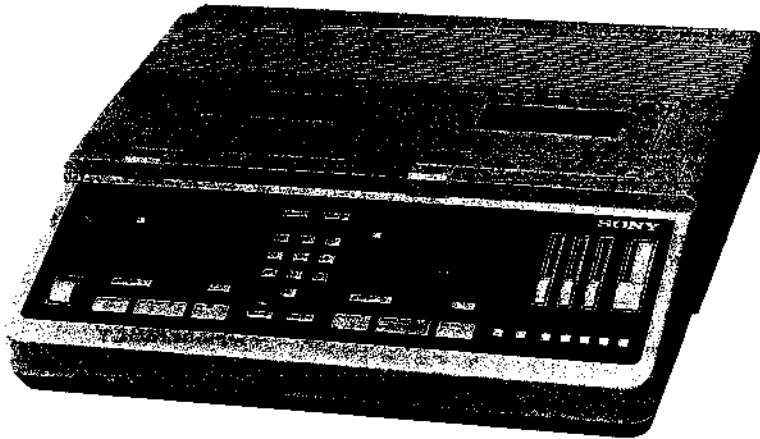

SPECIFICATIONS

Recording system	4-track, 4-channel monaural, one-way
Fast winding time	Approx. 2 min. 20 sec. with Sony C-90 cassette
Frequency response	200–6,000 Hz (2.4 cm/sec) 200–4,000 Hz (1.2 cm/sec)
Tape speed	2.4 cm/sec. ($1\frac{3}{16}$ ips) and 1.2 cm/sec. ($\frac{1}{2}$ ips)
Playback speed control range	Approx. +50% to -10% of normal speed at 2.4 cm/sec and 1.2 cm/sec.
Speaker	Approx. 7.7 cm ($3\frac{1}{16}$ inches) dia.
Power output	800 mW (at 10% harmonic distortion)
Inputs	Eight microphone inputs (type XLR-3) Sensitivity 0.2 mV (-72 dB) for low impedance microphone
Outputs	Earphone jack (mini jack) for 8-ohm earphone Public address connector (phone jack) for 10-kilohm amplifier Display connector for external digital counter display
Other connectors	Transcribing connector for the optional FS-75 foot control unit Recording remote control connector for the optional RM-45A remote control unit
Power requirements	220V AC, 50Hz (AEP Model) 240V AC, 50Hz (UK Model)
Power consumption	30W

Model Name Using Similar Mechanism	DECK A: BM-147
	DECK B: BM-147
Tape Transport Mechanism Type	DECK A: ME-246A-57
	DECK B: ME-246B-57

Dimensions	Approx. 351 × 86.5 × 342 mm (w/h/d) ($13\frac{7}{8}$ × $3\frac{3}{8}$ × $13\frac{1}{2}$ inches)
Weight	Approx. 5.72 kg (12 lb 10 oz) including projecting parts and controls
Accessories supplied	Cassette (2) Security key (2)



CONFER-CORDER
SONY®

FEATURES

Specially designed for recording courtroom proceedings, conferences or meetings.

Dual-deck confer-corder

With the AUTO CHANGE switch ON, long uninterrupted recording is possible. Before the end of tape on deck A (B), recording on deck B (A) starts automatically.

With the AUTO CHANGE switch OFF, both decks A and B can be operated simultaneously or separately.

4-track, 4-channel recording system

Eight microphone inputs into four channels can be recorded simultaneously. (The sound input from two microphones is mixed and recorded on one channel.)

Any channel or all can be selected for monitoring.

Search functions

A particular recorded segment of the tape can be quickly located and the end of the last recorded segment on the tape can easily be located.

Fail-safe warning system

Alarm sound and indication on the counter display prevent recording errors.

Recorded cassette protection

Built-in circuitry makes it impossible to record over a recorded segment on the cassette.

Digital tape counter and alarm indicator

The tape position (4-digit readout 0000 to 9999) cassette number (1, 2, 3, etc.) during continuous recording and alarm indication appear for easy reference.

Transcribing capability

With the use of the optional FS-75 foot control unit, deck B can be used for transcribing.

Recording of telephone calls

With the use of the optional RDI-246 telephone interface, up to four telephone lines can be connected for long uninterrupted recording of calls.

Public address and display jacks

A PA (public address) jack and DISPLAY connector (for optional remote display) are provided.

Security key lock



A security key locks the cassette holders of both decks A and B.

TABLE OF CONTENTS

<u>Section</u>	<u>Title</u>	<u>Page</u>
	Specifications	1
	Features	2
	Servicing Note	3
SECTION 1. GENERAL		4
1-1.	Location and Function of Controls	4
1-2.	Recording	5
1-3.	Tape Playback	6
1-4.	Public Address	6
1-5.	Search Function	7
1-6.	Information Display	7
1-7.	Alarm System	7
1-8.	Transcribing	8
1-9.	Remote Control Operation	8

<u>Section</u>	<u>Title</u>	<u>Page</u>
SECTION 2. OUTLINE		9
2-1.	IC901 (μ PD75108CW-151) Pin Functions	9
2-2.	IC901 (μ PD75108CW-151) Output Port and Mode	11
2-3.	Serial Signal	13
2-4.	Communication with RDI-246	14
2-5.	Fluorescent Display Drive (Dynamic) ..	15
2-6.	Detectors of Take-up Reel and Supply Reel Signals	16
2-7.	On the Key Matrix	17
SECTION 3. DISASSEMBLY		18
SECTION 4. MECHANICAL ADJUSTMENT ..		20
4-1.	Torque Measurement	20
4-2.	Tape Path Adjustment	20
4-3.	Rotor Thrust Adjustment	20
4-4.	Forward-Solenoid Position Adjustment ..	21
4-5.	F/R (Fast-Forward/Rewind) Solenoid Position Adjustment	21
SECTION 5. ELECTRICAL ADJUSTMENT ..		22
5-1.	Tape Speed Adjustment	22
5-2.	Motor Output Level Adjustment	22
5-3.	Record/Playback Head Azimuth Adjustment	23
5-4.	Monitor Head Azimuth Adjustment	23
5-5.	Tape Monitor Level Adjustment	24
5-6.	Frequency Response Check and Record Bias Adjustment	24
5-7.	Record Inhibit Azimuth Adjustment ..	25
SECTION 6. DIAGRAMS		26
6-1.	Circuit Boards Location	26
6-2.	Block Diagram	27
6-3.	Printed Wiring Boards (1) Servo Control Section	30
6-4.	Schematic Diagram (1) Servo Control Section	33
6-5.	Semiconductors Lead Layouts	39
6-6.	Printed Wiring Boards (2) Audio Section	41
6-7.	Schematic Diagram Audio Section	43
SECTION 7. EXPLODED VIEWS		47
SECTION 8. ELECTRICAL PARTS LIST ...		52

SAFETY-RELATED COMPONENT WARNING!!

COMPONENTS IDENTIFIED BY MARK  OR DOTTED LINE WITH MARK  ON THE SCHEMATIC DIAGRAMS AND IN THE PARTS LIST ARE CRITICAL TO SAFE OPERATION. REPLACE THESE COMPONENTS WITH SONY PARTS WHOSE PART NUMBERS APPEAR AS SHOWN IN THIS MANUAL OR IN SUPPLEMENTS PUBLISHED BY SONY.

Caution for Repair

1. Unless AC cord is plugged to power outlet and standby key switch turned to on mode, the cassette holder will not open.
2. This unit provides no eraser. Also, the unit provides protector for double recording: when it detects a recorded section on a tape, the mechanism shuts off and makes an alarm sound. Be sure to use an unrecorded tape.
3. Standby key switch does not turn power off. And unplug AC cord from power outlet to turn power off.

MODEL IDENTIFICATION

—Specifications Labels—

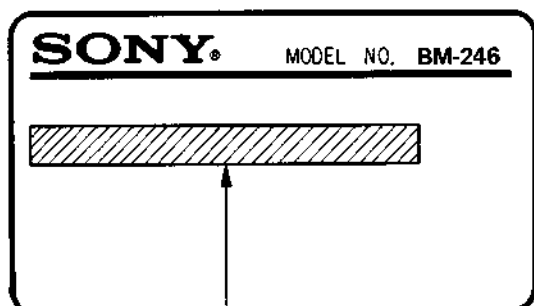

AEP model: AC: 220V~50Hz 30W
UK model: AC: 240V~50Hz 30W

SECTION 1 GENERAL

1-1. LOCATION AND FUNCTION OF CONTROLS

FRONT PANEL SIDE

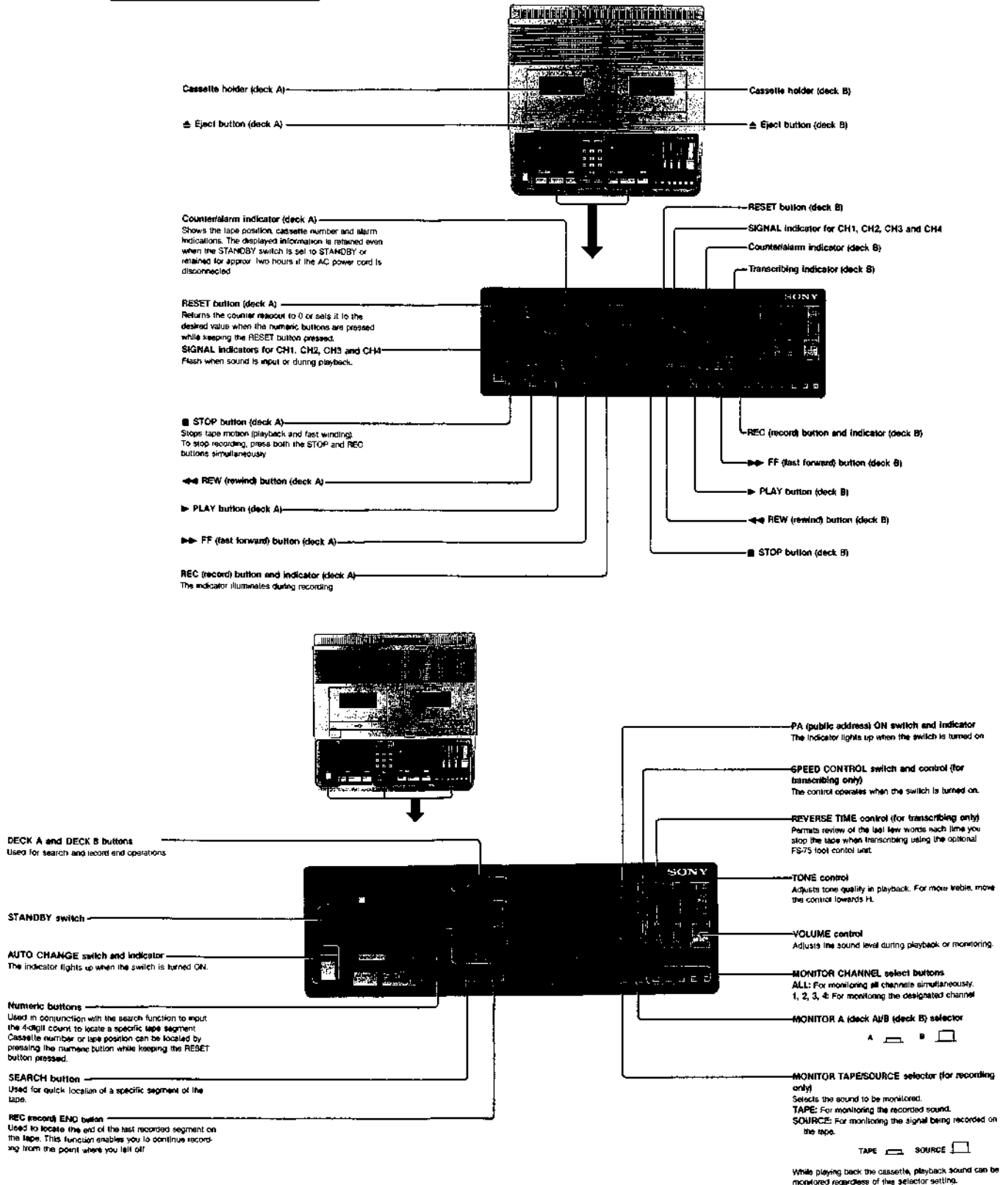

Rear panel

Microphone connectors (Cannon XLR-331 type)
Accepts microphones with XLR-312D type connector.



PA (public address) jack (phone jack)
Accepts the system to be connected to a public address system.

DISPLAY connector
Used for connection of an external counter unit.

CONTROL UNIT connector
Not used.

Left side

REMOTE jack

For connecting the optional RM-45A remote control unit. This enables remote start and stop of the tape on the deck which is in the record mode. For details, refer to the instruction manual of the RM-45A.

EARPHONE jack

Used for monitoring or listening in private.

TAPE SPEED selector

1.2 cm: 180 minutes of recording is possible with a DC90 cassette.
2.4 cm: 90 minutes of recording is possible with a DC90 cassette.
For playback, set this selector to the same position as was used when the cassette was recorded.

Right side

Connector for FS-75 foot control unit

Accepts the optional FS-75 foot control unit for transcribing.

TRANSCRIBE switch (for deck B only)

Activates the transcribing mode when the optional FS-75 foot control unit is connected.

1-2. RECORDING

Connection

Up to eight microphones can be connected.

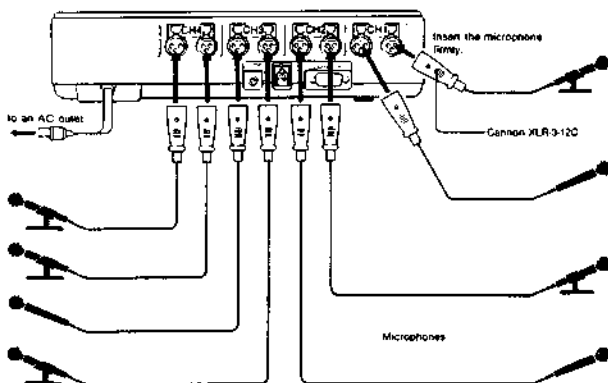

Note on continuous recording (See next page).
The AUTO CHANGE indicator lights up when the AUTO CHANGE switch is turned ON.

The indicator flickers rapidly to indicate that continuous recording is impossible even though the AUTO CHANGE switch is turned ON while recording both decks A and B or the TRANSCRIBE switch is turned ON.

The indicator flickers slowly to indicate that no cassette is in the cassette compartment of the deck for recording or that the deck is in the playback, fast forward or rewind mode.

To Continuously Record from Deck A to B or Vice Versa—Continuous Recording

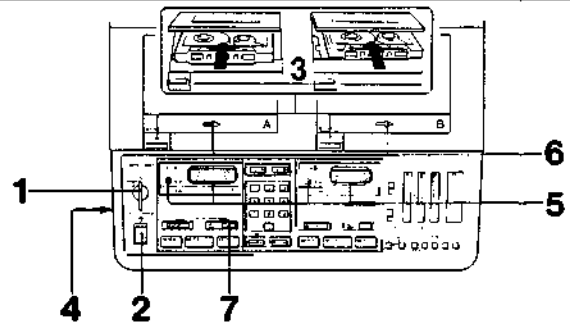

- 1 Insert the supplied security key and set it to ON.
- 2 Turn AUTO CHANGE ON.
- 3 Press Δ EJECT of both decks A and B and insert blank cassettes into the cassette holders.
- 4 Set TAPE SPEED.
- 5 Press RESET of both decks A and B. Cassette number and 0 (zero) for tape position appear on the counter.
- 6 Close the lid of both decks.
- 7 Press REC of deck A. Recording starts.

Approx. three minutes before the end of tape (when the tape approaches the end of tape)
The other deck starts recording automatically.

To stop recording
Press \square STOP and REC simultaneously.

For relay recording of more than three cassettes successively
Change the cassette in one deck while recording with the other. Endless recording can be done in this way.

Deck A and B can independently be operated
Tape playback and fast winding tape operations can be performed on one deck while recording on the other.

Cassette number is displayed
The leftmost digit of the counter indicates the cassette number when the AUTO CHANGE switch is turned ON. Cassette number increases each time the Δ EJECT button is pressed.

A Long time recording is possible
Recording time is prolonged corresponding to the setting of the TAPE SPEED selector and the cassette to be used.

Resetting of cassette number
When the RESET button is pressed and no cassette is in the cassette compartment, both the cassette number and tape segment can be reset.

Monitoring while recording

Insert an earphone into the EARPHONE jack.

MONITOR TAPE/SOURCE selector	Some (S) be monitored
TAPE	Recorded sound
SOURCE	Sound being recorded

Microphone input sound can also be monitored through the connected PA (public address) system if it is connected to this unit.

SIGNAL indicators

Blink when sound from a microphone is input.

To Record on a Deck—Single Recording

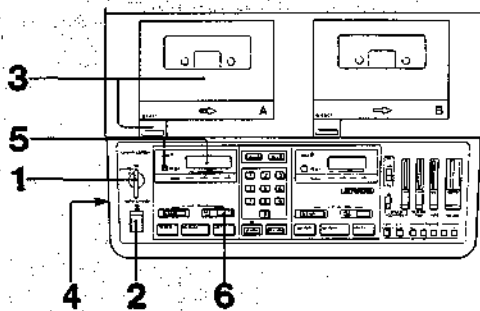

- 1 Insert the supplied security key and set the key to ON.
- 2 Turn AUTO CHANGE off.
- 3 Press Δ EJECT of either deck A or B and insert a blank cassette into the cassette holder. Close the lid.
- 4 Set TAPE SPEED.
- 5 Press RESET to set the counter to 0.
- 6 Press REC.

To stop recording
Press \blacksquare STOP and REC simultaneously.

To Record on Both Decks A and B Simultaneously—Dual Recording

Deck A and B can record the same input source simultaneously.

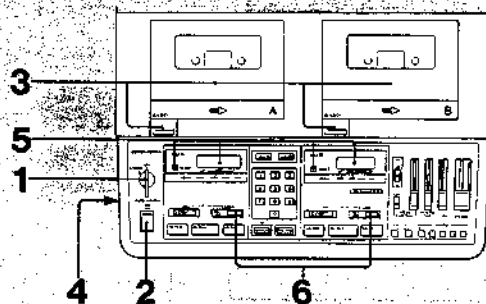

- 1 Insert the supplied security key and set the key to ON.
- 2 Turn AUTO CHANGE off.
- 3 Press Δ EJECT of both decks A and B and insert blank cassettes into the cassette holders. Close the lids.
- 4 Set TAPE SPEED.
- 5 Press RESET of both decks to set the counters to 0.
- 6 Press REC of both decks.

To stop recording
Press \blacksquare STOP and REC simultaneously.

1-3. TAPE PLAYBACK

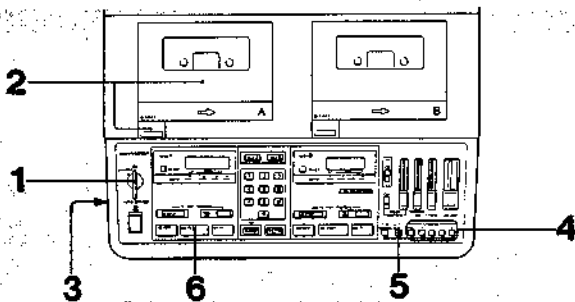

- 1 Insert the supplied security key and set the key to ON.
- 2 Press Δ EJECT and insert a recorded cassette into the cassette holder (deck A or B). Close the lid.
- 3 Set TAPE SPEED to the same position as that used for recording.
- 4 Depress the desired MONITOR CHANNEL.
- 5 Set MONITOR A/B to the desired position.
- 6 Press \blacktriangleright PLAY.

To stop playback
Press \blacksquare STOP.

For personal listening
Connect an earphone to the EARPHONE jack.

Sound adjustment
Adjust volume and tone with the VOLUME and TONE controls.

1-4. PUBLIC ADDRESS

Connection

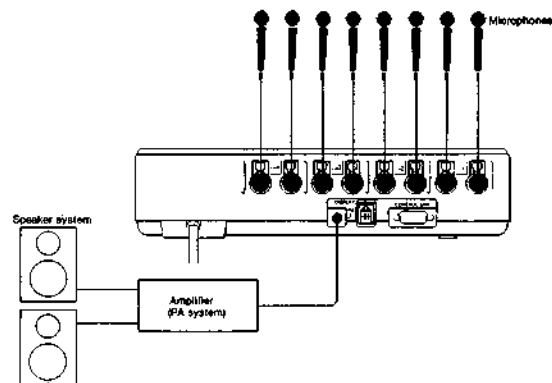

Operation

- 1 Turn ON PA.
- 2 Turn on the connected PA system.
- 3 Proceed with the operation steps described in "Tape Playback" to monitor during playback. Proceed with the operation steps described in "Recording" to monitor during recording.

Sound adjustment
Adjust the volume and tone on the PA system.
While recording
Input to a microphone in a courtroom, conference or meeting can be amplified.

Microphone testing
It can be performed through the connected PA system while stopping the tape motion.

1-5. SEARCH FUNCTION

To Quickly Locate a Specific Segment of Tape

You can quickly locate a specific segment of the tape when the counter readout has been reinitialized.

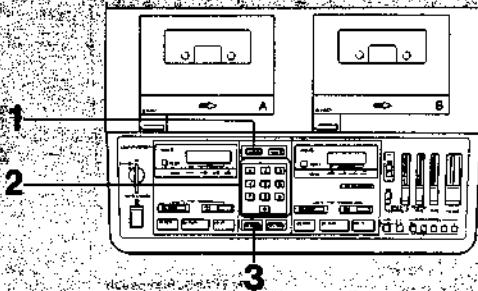

- 1 Press DECK A (or DECK B). The counter readout flickers.
- 2 Press the numeric buttons to set the counter readout to the specific tape segment you wish to find.
- 3 Press SEARCH. Tape is wound quickly to locate the specific tape segment.

The counter readout flickers
While searching for the specific segment.
To stop the search operation, press the DECK button again. Flickering stops.

To Quickly Find the Recording End

You can quickly find the recording end of the tape.

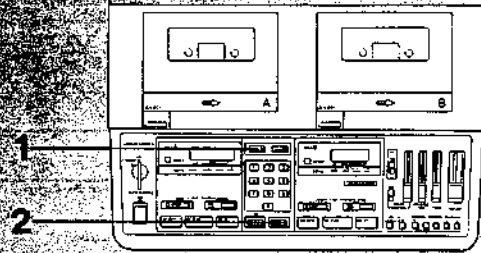

- 1 Press DECK A (or DECK B). The counter readout flickers.
- 2 Press REC END. The tape will stop automatically at the count number which corresponds to the end of the recording.

Note on record end function
If the count number on the counter is reset or a cassette is ejected once, the record-end memory is cleared and the record-end function does not operate.

1-6. INFORMATION DISPLAY

AUTO CHANGE OFF	
To select the deck	
To reset the counter readout	
For search operation	
For record-end operation	
For random reeling	
AUTO CHANGE ON	
To change the cassette number	

1-7. ALARM SYSTEM

An alarm sounds and indication appears on the display.

Alarm system	Situation	To release alarm system
	A tape operation button is pressed when no cassette is placed in the cassette compartment.	
	A deck starts recording automatically when no cassette is in the cassette compartment (during continuous recording).	
	Broken tape End of tape	

Alarm system	Situation	To release alarm system
	Approx. three minutes before the end of tape (while recording)	
	Record on the pre-recorded portion. A deck starts recording automatically when the counter deck is set in the play/deck, fast forward or rewind mode.	

1-8. TRANSCRIBING

The deck B can be used as a transcriber by connecting the optional FS-75 foot control unit.

Connection

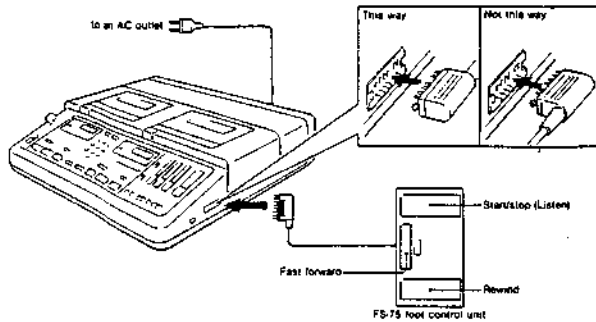

Operation

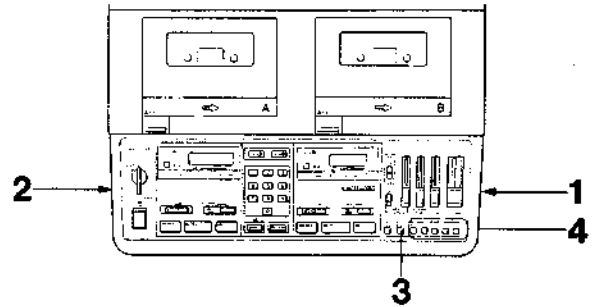

- 1 Set TRANSCRIBE to ON.
- 2 Set TAPE SPEED to the same position as that used for recording.
- 3 Keep MONITOR A/B released (B).
- 4 Depress the desired MONITOR CHANNEL.

To control transcribing speed
Transcribing speed can be controlled.

- 1 Turn ON the SPEED CONTROL switch.
- 2 Set the SPEED CONTROL to your preference.
To increase playback speed, move the control toward +.
To decrease the speed, move the control toward -.

To obtain the original speed
Turn off SPEED CONTROL.

Each time you resume listening
The last few words can be reviewed.
When the REVERSE TIME control is moved upwards, the last portion of the tape will be reviewed by using the start/stop function of the FS-75.
At + position, the BM-246 stops to review about the last six seconds.
At - position, this unit stops without reviewing.
Set the control so that it clicks into position.

Notes

- REVERSE TIME and SPEED CONTROL are operative only when the optional FS-75 foot control unit is connected.
- When the TRANSCRIBE switch is turned on, deck A is inoperative.

The TRANSCRIBE indicator blinks
To indicate that the transcribing mode is inoperative even though the TRANSCRIBE switch is turned ON when the AUTO CHANGE switch is turned ON or either deck is being operated.

1-9. REMOTE CONTROL OPERATION

You can remotely control the BM-246 by using the optional RM-45A remote control unit.
Remote control operation is performed when the BM-246 is set in record mode.

Connection

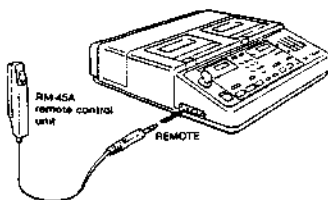

Operation

Press REC.

Then, start/stop operation can be performed on the RM-45A remote control unit.

The REC indicator flickers rapidly when the remote control unit stops the BM-246.

SECTION 2 OUTLINE

2-1. IC901 (μ PD75108CW-151) pin Functions

Pin No.	NAMING	SYMBOL	PORT NAME	PORT	I/O	FUNCTION
1	REC-INHI-B-IN	INHI-B	PORT 1	P13	I	INHIBIT-B signal input. "L": STOP.
2	REC-INHI-A-IN	INHI-A		P12	I	INHIBIT-A signal input. "L": STOP.
3	S-REEL-B-IN	SBI		P11	I	B deck S REEL drive signal input.
4	S-REEL-A-IN	SAI		P10	I	A deck S REEL drive signal input.
5	FS IN	FSI	PTH0	PTH03	I	FORWARD SPACE signal input. "L": actuate.
6	BS IN	BSI		PTH02	I	BACK SPACE signal input. "L": actuate.
7	F-LIS IN	LISI		PTH01	I	FOOT-LIS signal input. "L": actuate.
8	OPEN	M5V		PTH00	-	Not used.
9	T-REEL-A-IN	TAI	TI	T10	I	A deck T REEL drive signal input.
10	T-REEL-B-IN	TBI		T11	I	B deck T REEL drive signal input.
11	PG-FR-A	PGFR-A	PORT 2	P23	O	A deck PG (FF) output "L": actuate.
12	PG-FWD-A	PGF-A		P22	O	A deck PG (FWD) output. "L": actuate.
13	REC-A-CNT	REC-A		P21	O	A deck REC control output. "H": REC AMP MUTE, "L": REC AMP ON.
14	PG-FR-B	PGFR-B		P20	O	B deck PG (FF) output. "L": actuate.
15	REMOTE IN	RMTI	PORT 0	P03	I	REMOTE signal input. "H": stop, "L": actuate.
16	SERIAL OUT	DATA		P02	O	SERIAL DATA signal output. RDC \times 4, TRANSCRIBE LED (D945), RELAY output \times 2, ALARM "L": actuate. (See waveform on page 13.)
17	SERIAL CLOCK	SCK		P01	O	SERIAL CLOCK signal output. (See waveform on page 13)
18	STBY IN	STBY		P00	I	Detects power supply +12V. "L": Operation mode, "H": STANDBY mode.
19	PG-FWD-B	PGF-B	PORT 12	P123	O	B deck PG (FWD) output "L": actuate.
20	REC-B-CNT	REC-B		P122	O	B deck REC control output. "H": REC AMP MUTE, "L": REC AMP ON.
21	PB-A-CNT	PB-A		P121	O	A deck PB control output. "H": PB AMP MUTE, "L": PB AMP ON.
22	LED (REC-A)	LED RA		P120	O	A deck REC LED (D918) drive output. "L": actuate.
23	LED (AUTO)	LED RL	PORT 13	P133	O	AUTO CHANGE LED (D916) drive output. "L": actuate.
24	TEL DATA	T DATA1		P132	O	T DATA signal output to RDI-246. (See waveform on page 14).
25	PB-B-CNT	PB-B		P131	O	B deck PB control output. "H": PB AMP MUTE, "L": PB AMP ON.
26	LED (REC-B)	LED RB		P130	O	B deck REC LED (D917) drive output. "L": actuate.
27	TEL-REC-IN	TEL 1	PORT 14	P143	I	RDI-246 TEL-REC signal input. (See waveform on page 14.)
28	KSCAN IN 2	SCAN 2		P142	I	Key scan input. "H": actuate. (See a table on page 17.)
29	KSCAN IN 1	SCAN 1		P141	I	
30	KSCAN IN 0	SCAN 0		P140	I	
31	NC	M5V	-	-	-	Not connected.
32	VDD	M5V	-	-	-	+5V power supply.
33	SPD-CONTROL	VSI	PORT 3	P33	O	Regular speed/speed change switch. "H": speed change, "L": regular speed.
34	A OFF-B	A OFF B		P32	O	B deck AUTO OFF signal output. "H": STOP, "L": ON.
35	RVS-B	RVS-B		P31	O	B deck REVERSE signal output. "H": REVERSE (Same as FF), "L": FORWARD. (Same as FWD, REW).
36	1.2/2.4-B	SPD-B		P30	O	B deck tape speed switch. "H": 1.2cm/s, "L": 2.4cm/s.
37	1.2/2.4-A	SPD-A	PORT 4	P43	O	A deck tape speed switch. "H": 1.2cm/s, "L": 2.4cm/s.
38	DISP Bg	Bg 1		P42	O	B deck display segment output. "H": actuate.
39	DISP Bf	Bf 1		P41	O	
40	DISP Be	Be 1		P40	O	

Pin No.	NAMING	SYMBOL	PORT NAME	PORT	I/O	FUNCTION
41	DISP Bd	Bd 1	PORT 3 ↑ ↓	P53	O	B deck display segment output. "H": actuate.
42	DISP Bc	Bc 1		P52	O	
43	DISP Bb	Bb 1		P51	O	
44	DISP Ba	Ba 1		P50	O	
45	RESET	RESET	-	-	I	Microcomputer HARD RESET signal input.
46	X1	X1	-	-	-	Clock oscillator terminal. (4.19 MHz)
47	X2	X2	-	-	-	
48	STAND-BY-SW IN	PSW	PORT 6 ↑ ↓	P63	I	STANDBY switch (S935) detect input. "H": STANDBY switch off, "L": STANDBY switch on.
49	A OFF-A	A OFF-A		P62	O	A deck AUTO OFF signal output. "H": STOP, "L": ON.
50	RVS-A	RVS-A		P61	O	A deck REVERSE signal output. "H": REVERSE (Same as FF), "L": FORWARD (Same as FWD, REW).
51	DISP D0	D0-1		P60	O	Display digit output (1 figure). "H": actuate.
52	DISP D1	D1-1	PORT 7 ↑ ↓	P73	O	Display digit output (10 figures). "H": actuate.
53	DISP D2	D2-1		P72	O	Display digit output (100 figures). "H": actuate.
54	DISP D3	D3-1		P71	O	Display digit output (1000 figures). "H": actuate.
55	DISP D4	D4-1		P70	O	Display digit output (10000 figures). "H": actuate.
56	SERIAL LATCH	LAT	PORT 8 ↑ ↓	P83	O	SERIAL LATCH signal output. "L": actuate. (See waveform on page 13).
57	DISP Ag	Ag 1		P82	O	A deck display segment output. "H": actuate.
58	DISP Af	Af 1		P81	O	
59	DISP Ae	Ae 1		P80	O	
60	DISP Ad	Ad 1	PORT 9 ↑ ↓	P93	O	A deck display segment output. "H": actuate.
61	DISP Ac	Ac 1		P92	O	
62	DISP Ab	Ab 1		P91	O	
63	DISP Aa	Aa 1		P90	O	
64	VSS	GND	-	-	-	Ground terminal.

2-2. IC901 (μ PD75108CW-151) Output Port and Mode

A DECK									
Port	Pin No.	Function	STOP	REC	PLAY	FF	REW	AUTO OFF (note 1)	
P20	14	PG (FF) B	-						
P21	13	REC CONTROL A	H	L	H	H	H	H	
P22	12	PG (FWD) A	H	L	L	H	H	H	
P23	11	PG (FF) A	H	H	H	L	L	H	
P30	36	1.2/2.4 B	-						
P31	35	REVERSE B	-						
P32	34	AUTO OFF B	-						
P33	33	REGULAR SPEED /SPEED CHANGE	-						
P43	37	1.2/2.4 A	(note 2)	(note 2)	(note 2)	L	L	(note 2)	
P61	50	REVERSE A	L	L	L	H	L	L	
P62	49	AUTO OFF A	L	L	L	L	L	H (MOTOR STOP)	
P120	22	LED (REC) A	H (note 3)	L (note 4)	H	H	H	H (note 3)	
P121	21	PB CONTROL A	H	H	L	H	H	H	
P122	20	REC CONTROL B	-						
P123	19	PG (FWD) B	-						
P130	26	LED (REC) B	-						
P131	25	PB CONTROL B	-						
P01	17	SERIAL CLOCK	-						
P02	16	SERIAL DATA	H (note 5)	L (note 6)	H (note 5)	H (note 5)	H (note 5)	H (note 5)	
P83	56	SERIAL LATCH	-						
P132	24	RDI-246 SERIAL DATA	-						

(note 1) When STOP mode stays more than 3 minutes it goes to AUTO OFF.

(note 2) SPEED switch (S101) switches 1.2/2.4 cm/s.

(note 3) When RDI-246 is connected, TELEPHONE STANDBY: "L", REMOTE STOP: "H"/"L" and LED blinks.

(note 4) PRE-END alarm: "H"/"L", and LED blinks.

(note 5) SERIAL 0 bit: "H".

(note 6) SERIAL 0 bit: "L".

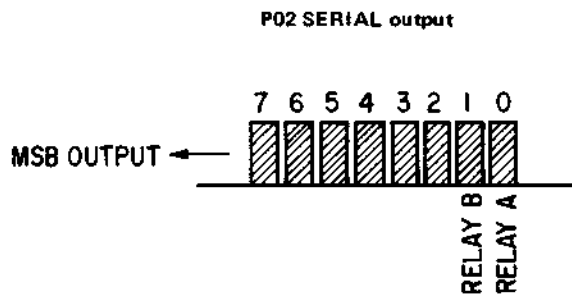

B DECK									
Port	Pin No.	Function	STOP	REC	PLAY FOOT LIS	FF FS	REW PR BS	AUTO OFF (note 1)	
P20	14	PG (FF) B	H	H	H	L	H	H	
P21	13	REC CONTROL A	-						
P22	12	PG (FWD) A	-						
P23	11	PG (FF) A	-						
P30	36	1.2/2.4 B	(note 2)	(note 2)	(note 2)	L	L (note 7)	(note 2)	
P31	35	REVERSE B	L	L	L	H	L	L	
P32	34	AUTO OFF B	L	L	L	L	L	H (MOTOR) STOP	
P33	33	REGULAR SPEED /CHANGE SPEED	L	L	(note 8)	L	L	L	
P43	37	1.2/2.4 A	-						
P61	50	REVERSE A	-						
P62	49	AUTO OFF A	-						
P120	22	LED REC A	-						
P121	21	PB CONTROL A	-						
P122	20	REC CONTROL B	H	L	H	H	H	H	
P123	19	PG (FWD) B	H	L	L	H	H	H	
P130	26	LED (REC) B	H (note 3)	L (note 4)	H	H	H	H (note 3)	
P131	25	PB CONTROL B	H	H	L	H	H	H	
P01	17	SERIAL CLOCK	-						
P02	16	SERIAL DATA	(note 10)	(note 9)	(note 10)	(note 10)	(note 10)	(note 10)	
P83	56	SERIAL LATCH	-						
P132	24	RDI-246 SERIAL DATA	-						

(note 1-6) See note on page 11.

(note 7) REW, BACK SPACE: Stays "L", PARTIAL REVERSE: Same as note 2.

(note 8) TRANSCRIBE (S934 ON) PLAY: Normally "L", FOOT LIS: "H".

(note 9) SERIAL 1 bit: "L".

(note 10) SERIAL 1 bit: "H".

2-3. SERIAL SIGNAL

IC901 Pin (17) (SERIAL CLOCK), Pin (16) (SERIAL DATA), Pin (56) (SERIAL LATCH) only serial signals to port extension IC μ PD4094BC (IC128).

Each waveform timing is shown below.

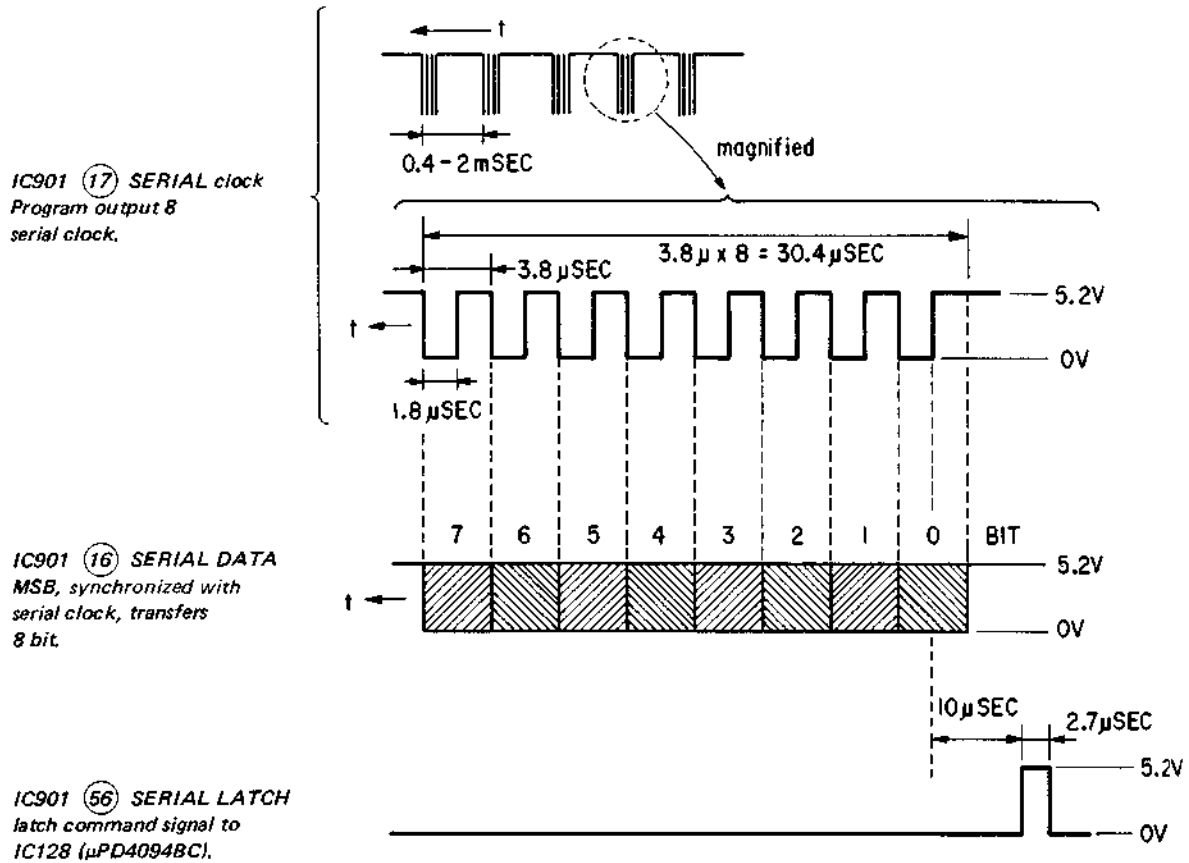

• SERIAL DATA

Bit	Naming	IC128 Output Port	Function	IC901 (16) pin	
				H	L
0	RELAY A	pin (4)	DECK A Relay, Bias drive.	OFF	RELAY ON
1	RELAY B	pin (5)	DECK B Relay, Bias drive	OFF	RELAY ON
2	ALARM	pin (6)	IC127 Alarm circuit drive.	OFF	ON
3	TRANSCRIBE LED	pin (7)	D945 drive.	ON	OFF
4	RDC RESET	pin (14)	External counter for RDC-146 reset.	RESET ON	-
5	RDC CLOCK	pin (13)	External counter for RDC-146 count pulse.	NORMAL	CLOCK OUTPUT
6	RDC U/D	pin (12)	External counter for RDC-146 count pulse.	DOWN	UP
7	RDC D	pin (11)	External counter for RDC-146 tape number increment.	INCREMENT	NORMAL

2-4. COMMUNICATION WITH RDI-246

(1) TEL REC input signal (IC901 pin 27).

TEL REC signal is an input signal from RDI-246 to the unit, which controls REC/STOP of the unit.

• Signal waveform (IC901 pin 27)

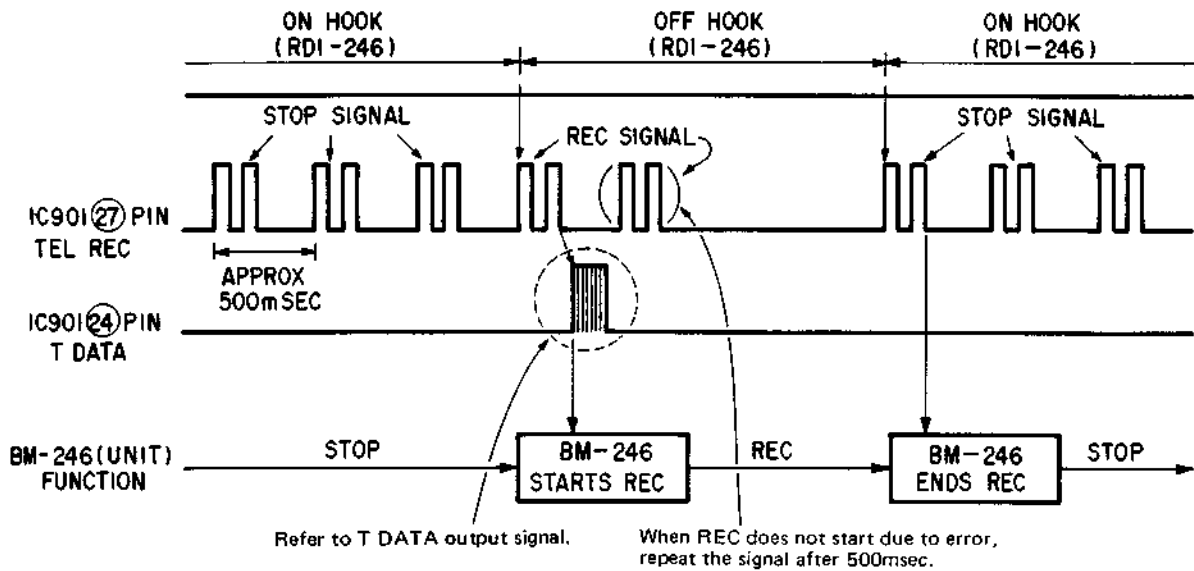
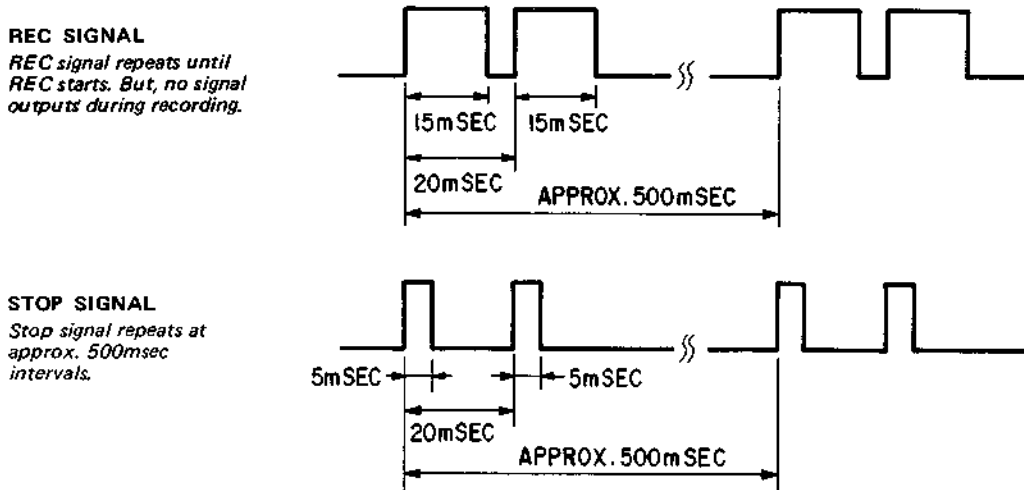

(2) T DATA output signal (IC901 pin 24)

T DATA signal is an output signal from the unit to RDI-246. When the unit goes to REC mode, it sends deck counter value and deck A/B to RDI-246.

• Signal waveform (IC901 pin 24)

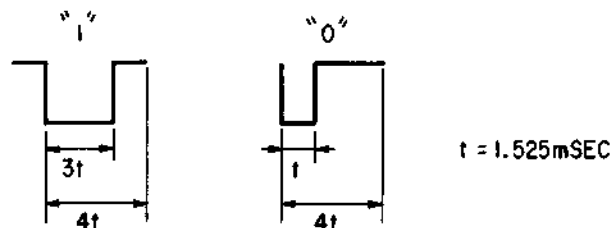

• DATA Format

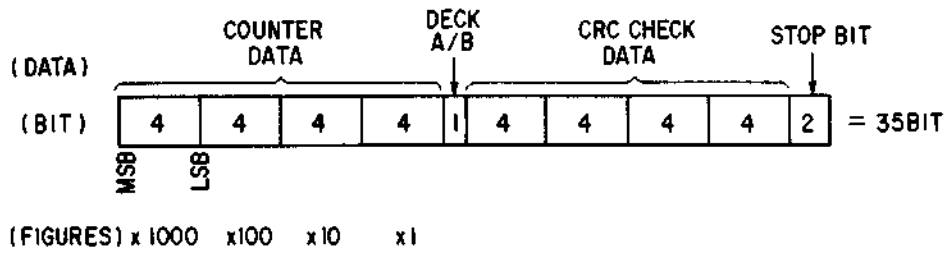

2-5. FLUORESCENT DISPLAY DRIVE (Dynamic)

SEGMENTS

	IC901 Pin No.						
A deck LED	63	62	61	60	59	58	57
B deck LED	44	43	42	41	40	39	38
Segment	a	b	c	d	e	f	g

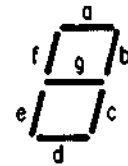

GRIDS

	10000 Figures	1000 Figures	100 Figures	10 Figures	1 Figures
Grid	G4	G3	G2	G1	G0
IC901 Pin No.	55	54	53	52	51

Relationship of Grid-drive Signals

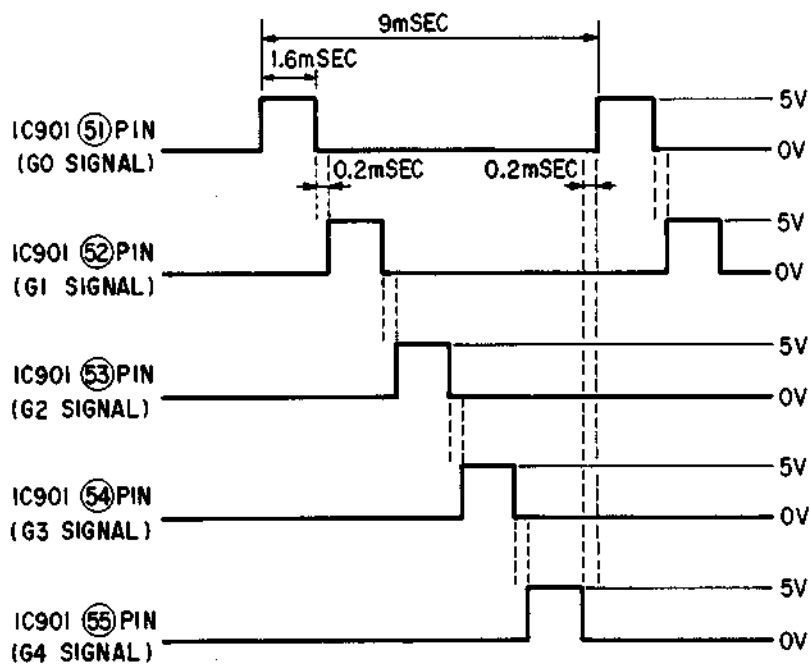

2-6. DETECTIONS OF TAKE-UP REEL AND SUPPLY REEL SIGNALS

IC901 (9) pin (A deck), (10) pin (B deck)
 ... TAKE-UP-REEL

IC901 (4) pin (A deck), (3) pin (B deck)
 ... SUPPLY REEL

• **Forward**

Take-up reel signal at start of tape and supply reel signal at end of tape, C-90.

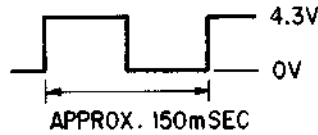

Supply reel signal at start of tape and take-up reel signal at end of tape, C-90.



Repetition rate changes according to tape position.

• **Fast-forward and Rewind**

Take-up reel signal at start of tape and supply reel signal at end of tape, C-90.

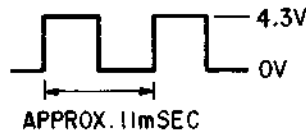

Supply reel signal at start of tape and take-up reel signal at end of tape, C-90.

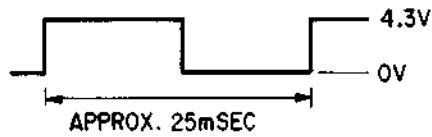

Repetition rate changes according to tape position.

Partial-reverse Amount Control-signal Inputs

Scan input IC901 (28) pin	REVERSE TIME (Digital) Switch S933	Position of S933									
		0	1	2	3	4	5	6	7	8	9
PR0	pin 1	H	L	H	L	H	L	H	L	H	L
PR1	pin 2	H	H	L	L	H	H	L	L	H	H
PR2	pin 3	H	H	H	H	L	L	L	L	H	H
PR3	pin 4	H	H	H	H	H	H	H	H	L	L

2-7. ON THE KEY MATRIX

On the key matrix table.

The key matrix of this set is configured as shown below.

KEY SCAN OUTPUT (COMMON PORT)			63 pin	62 pin	61 pin	60 pin	59 pin	58 pin	57 pin	
			P90	P91	P92	P93	P80	P81	P82	
			PORT 9				PORT 8			
			A deck segment							
KEY SCAN INPUT			a	b	c	d	e	f	g	
PORT 14	30 pin P140	KS0	STOP A	REW A	CASSETTE EMPTY A	AUTO CHANGE SW	1	4		
	29 pin P141	KS1	FF A	REC A	REST A	TRANS-SCRIBE SW	2	5		
	28 pin P142	KS2	PLAY A	PR0	DECK SW A	PR1	3	6		

KEY SCAN OUTPUT (COMMON PORT)			44 pin	43 pin	42 pin	41 pin	40 pin	39 pin	38 pin	
			P50	P51	P52	P53	P40	P41	P42	
			PORT 5				PORT 4			
			B deck segment							
KEY SCAN INPUT			a	b	c	d	e	f	g	
PORT 14	30 pin P140	KS0	STOP B	REW B	CASSETTE EMPTY B		7	0	OPEN	
	29 pin P141	KS1	FF B	REC B	RESET B		8	SEARCH	1.2/2.4 SW	
	28 pin P142	KS2	PLAY B	PR2	DECK SW B		9	REC END	PR3	

- Scan Direction

Deck A
d→c→b→a→f→e

Deck B
c→d→a→g→f→e

- RR0 - PR3 detects S933 (PARTIAL-REVERSE)
- "H": actuate

	"H"	"L"
1.2/2.4	1.2	2.4
REMOTE	actuate	STOP
CASSETTE EMPTY	NO cassette	Cassette loaded

- Alternately check PORT 9, 8 and 5, 4

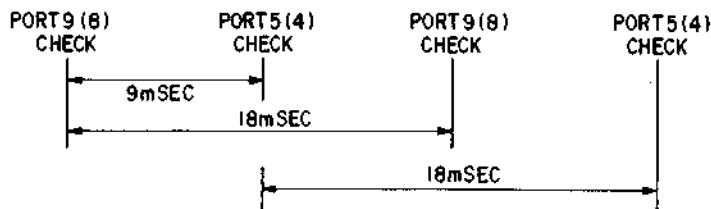

SECTION 3 DISASSEMBLY

Note: Follow the disassembly procedure in the numerical order given.

VERTICAL ADJUSTMENT COVER

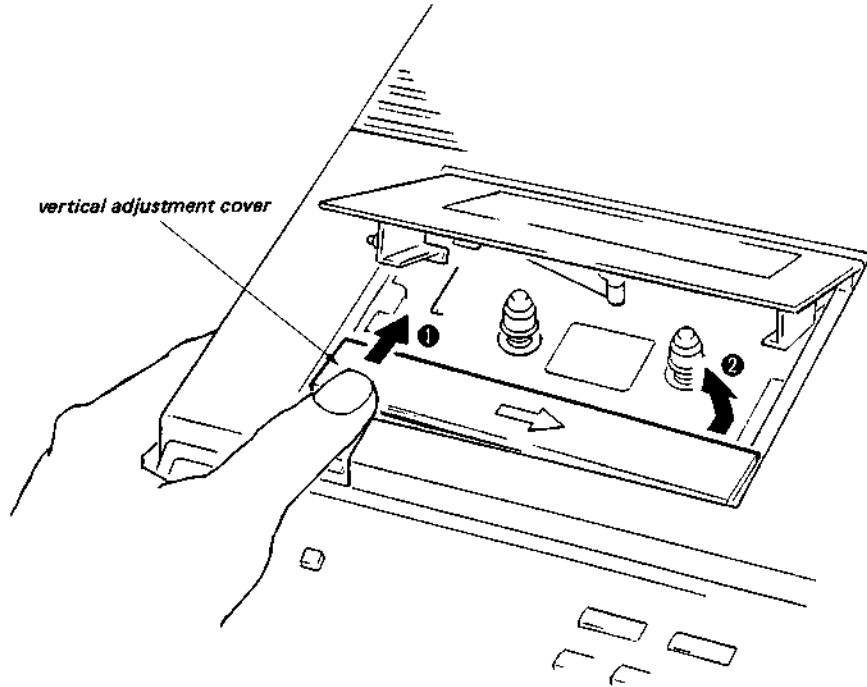

CONTROL BOARD

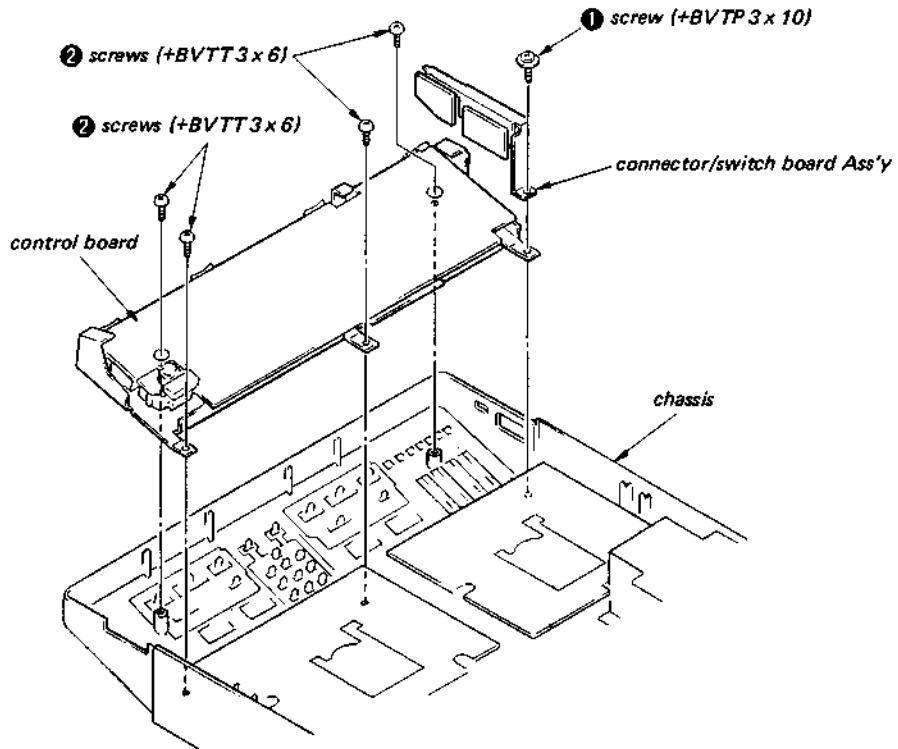

SERVO BOARD

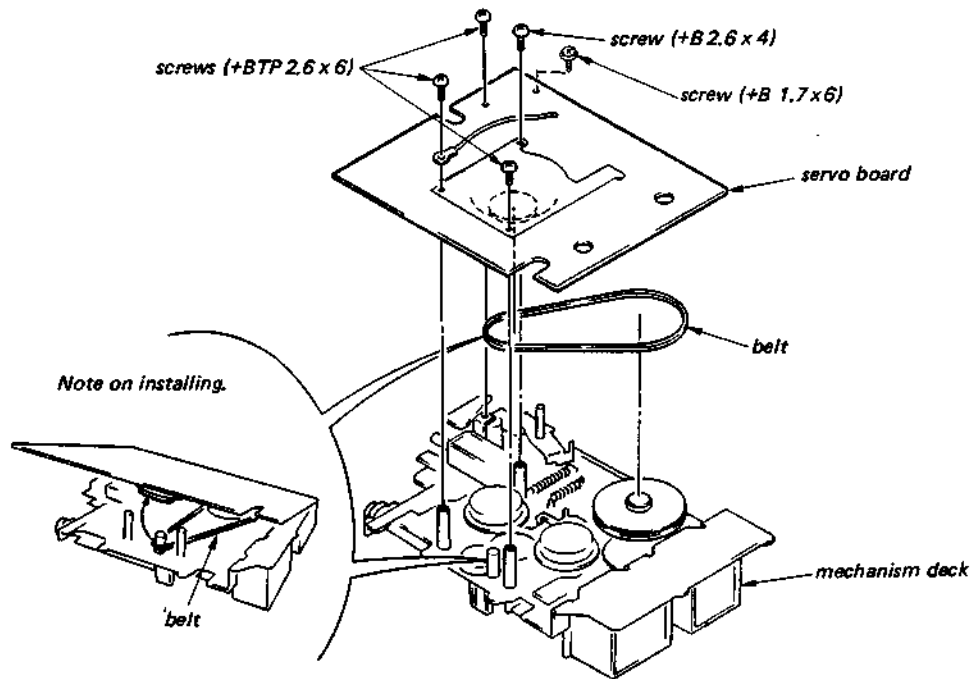

HEAD

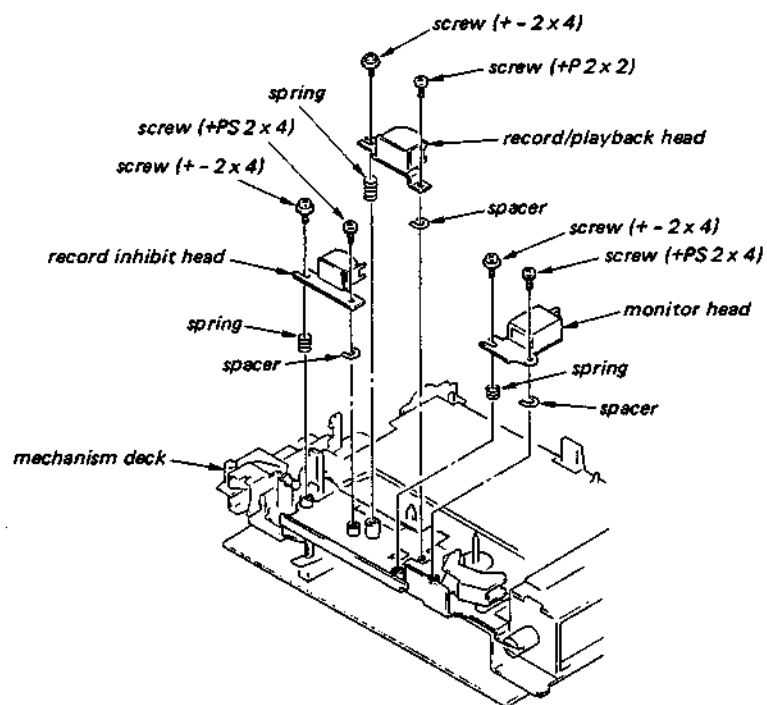

SECTION 4 MECHANICAL ADJUSTMENTS

PRECAUTION

1. Clean the following parts with a denatured-alcohol-moistened swab:

record/playback head	Pinch roller
monitor head	rubber belts
record inhibit head	idlers
capstan	
2. Demagnetize the record/playback head, monitor head and record inhibit head with a head demagnetizer.
3. Do not use a magnetized screwdriver for the adjustments.
4. After the adjustments, apply suitable locking compound to the parts adjusted.
5. The adjustments should be performed with the rated power supply voltage unless otherwise noted.

4-1. TORQUE MEASUREMENT DECK A/DECK B

Torque	Torque meter	Meter reading
FWD	CQ-102C	28 to 40 g·cm (0.39 to 0.56 oz·inch)
FWD Back tension	CQ-102C	1.5 to 4.5 g·cm (0.02 to 0.06 oz·inch)
FF, REW	CQ-201B	70 to 190 g·cm (0.98 to 2.66 oz·inch)

Tape Tension Measurement

Mode	Tension meter	Meter reading
FWD	CQ-403A	more than 100 g (more than 1.4 oz·inch)

4-2. TAPE PATH ADJUSTMENT DECK A/DECK B

Procedure:

1. Insert the mirror cassette (CQ-009 or CQ-012C).
2. Set TAPE SPEED switch to 2.4 cm.
3. In playback mode and viewing from the front, adjust the head heights to eliminate tape curl and tape twist at portions of arrows.
4. Make sure of head azimuth adjustments in electrical adjustments section.

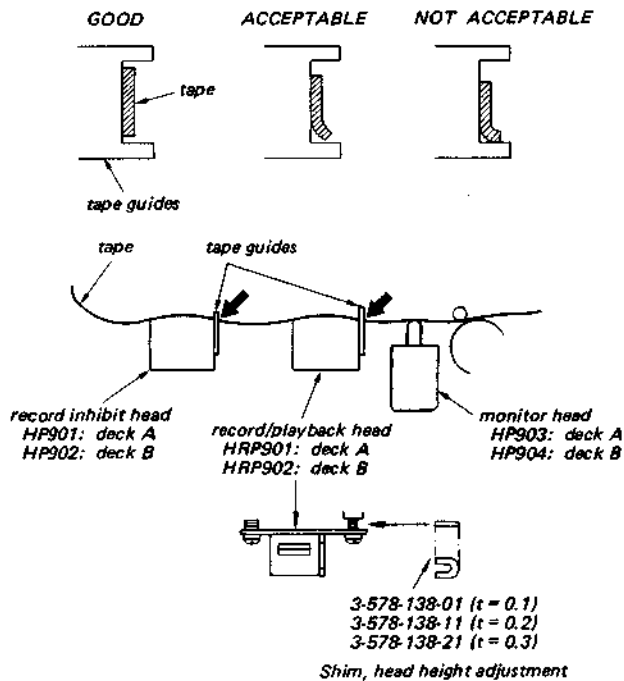

4-3. ROTOR THRUST ADJUSTMENT

DECK A/ DECK B

— Stop Mode —

Adjust thrust screw so that the specified clearance is obtained.

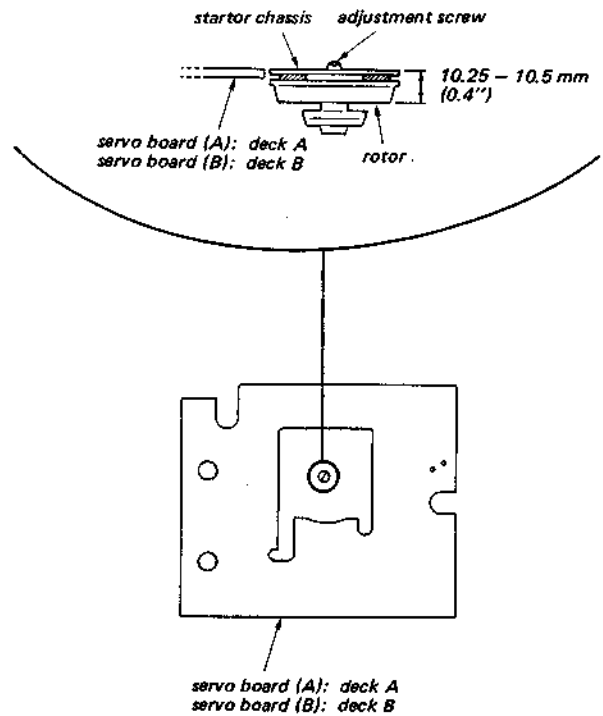

4-4. FORWARD-SOLENOID POSITION ADJUSTMENT

DECK A/ DECK B

Procedure:

1. Unplug CNJ603 (DECK A), CNJ703 (DECK B) for PM603 (DECK A), PM703 (DECK B) at servo board (A) and (B).
2. Apply 17V dc voltage to solenoid terminals. Red lead is positive side.
3. Loosen adjustment screws.
4. Move solenoid and tighten adjustment screws retaining the position of S cam as shown in Fig. A.
5. Plug CNJ603 (DECK A), CNJ703 (DECK B) to servo board (A) and (B) put the unit in playback mode.
At this time, clearance should exist between forward level and pinch lever as illustrated.
6. After adjustment, apply suitable locking compound to adjustment screws.

4-5. F/R (FAST-FORWARD/REWIND) SOLENOID POSITION ADJUSTMENT

DECK A/DECK B

Procedure:

1. Unplug CNJ602 (DECK A), CNJ702 (DECK B) for PM602 (DECK A), PM702 (DECK B) at servo board (A) and (B).
2. Apply 17V dc voltage to solenoid terminals. Red lead is positive side.
3. Loosen adjustment screws.
4. Move solenoid and tighten adjustment screws retaining the position of S cam as shown in Fig. B.
5. After adjustment, apply suitable locking compound to adjustment screws.

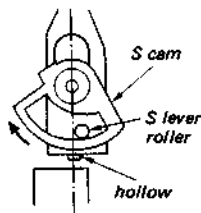

Fig. A Solenoid attracted

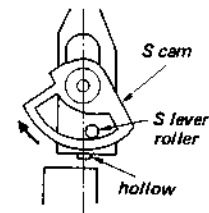
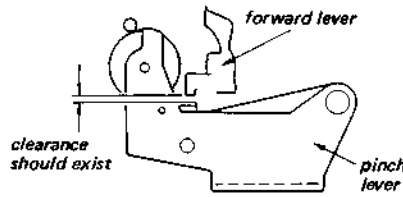
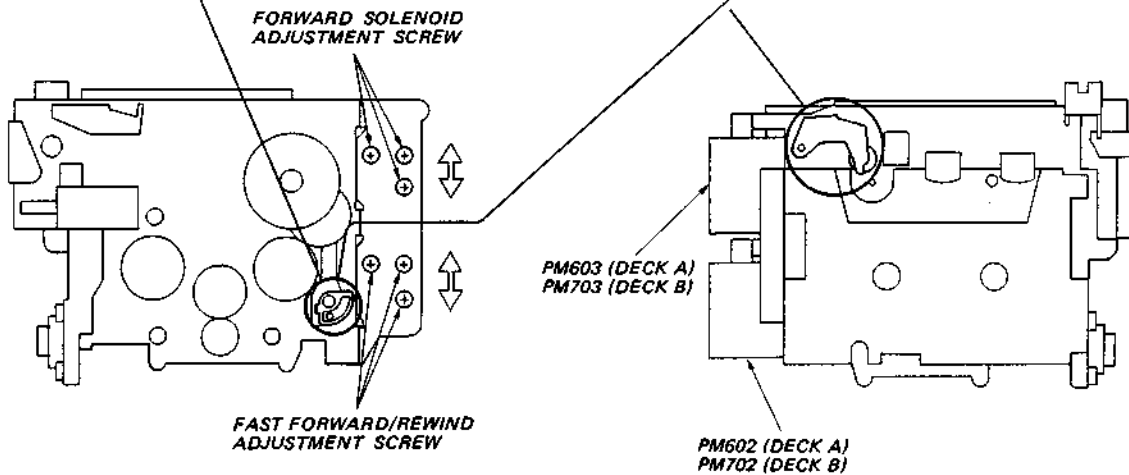

Fig. B Solenoid attracted



SECTION 5 ELECTRICAL ADJUSTMENTS

- The adjustments should be performed in the order given in this service manual. (As a general rule, playback circuit adjustment should be completed before performing recording circuit adjustment.)
- Switches and controls should be set as follows unless otherwise specified.

STANDBY/ON	ON
AUTO CHANGE	OFF
TAPE SPEED	2.4cm
PA	OFF
TRANSCRIBE	OFF
SPEED CONTROL	OFF
TAPE/SOURCE	SOURCE
CHANNEL SELECT	CH2
TONE	MAX
VOLUME	Mechanical mid
- Standard Record:

Deliver the standard input signal level to the input jack and control the attenuator to obtain the standard output signal level.

Mode: record

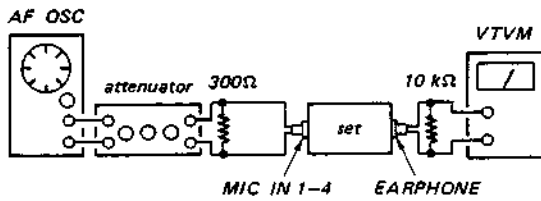

Standard Input Level

	MIC IN 1-4
source impedance	300Ω
input level	0.775 mV (-60 dB)

Standard Output Level

	Speaker	Earphone
load impedance	8Ω	10kΩ
output level	0.775 V (0 dB)	0.775 V (0 dB)

5-1. TAPE SPEED ADJUSTMENT DECK A/DECK B

Setting:

- CHANNEL SELECT switch: CH2
- TRANSCRIBE switch: OFF
- SPEED CONTROL switch: OFF

Procedure:

Mode: playback

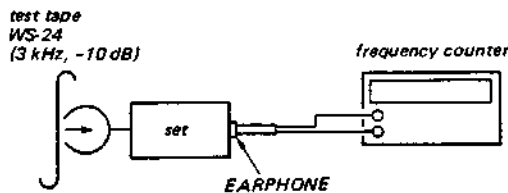

- TAPE SPEED switch: 2.4 cm
Adjust RV603 (DECK A), RV703 (DECK B) so that the reading on frequency counter is $3,000 \pm 8$ Hz.

- TAPE SPEED switch: 1.2 cm
Adjust RV604 (DECK A), RV704 (DECK B) so that the reading on frequency counter is $1,500 \pm 4$ Hz.
- DECK B ONLY
TRANSCRIBE switch: ON
SPEED CONTROL switch: ON
SPEED CONTROL knob: MAX
TAPE SPEED switch: 2.4 cm
Confirm that the reading on frequency counter is 4,500 - 5,400 Hz.
- DECK B ONLY
SPEED CONTROL knob: MIN
TAPE SPEED switch: 1.2 cm
Adjust RV702 so that the reading on frequency counter is $1,275 \pm 8$ Hz.

Adjustment Location:

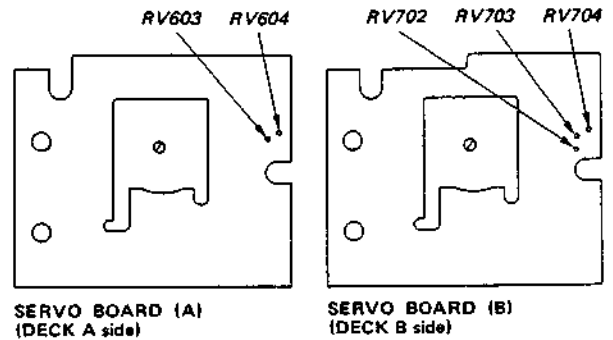

5-2. MOTOR OUTPUT LEVEL ADJUSTMENT

DECK A/DECK B

Setting:

TAPE SPEED switch: 2.4 cm

Procedure:

Mode: playback

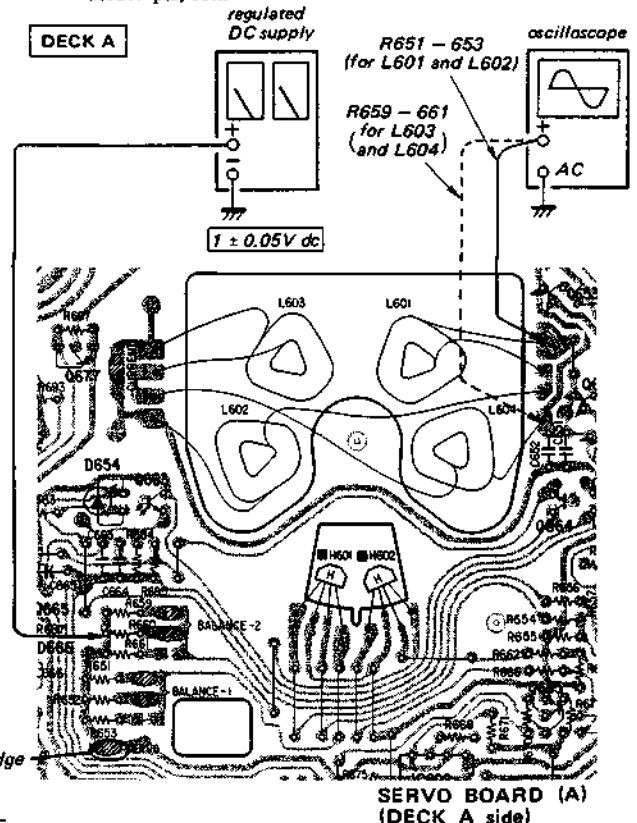

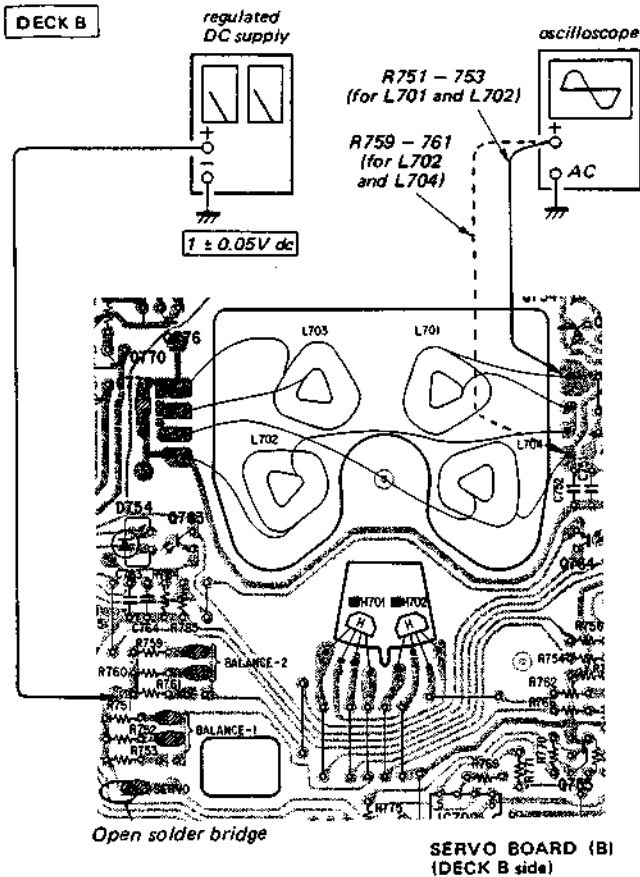

1. Adjust output voltage by selecting solder bridge for R651 through R653 (DECK A), R751 through R753 (DECK B) for L601 and L602 (DECK A), L701 and L702 (DECK B), and R659 through R661 (DECK A), R759 through R761 (DECK B) for L603 and L604 (DECK A), L703 and L704 (DECK B), to obtain an 8 ± 1 V_{p-p} level.
2. After the adjustment, remove external dc supply, and make a solder bridge again to the patterns opened at the setup above.

Adjustment Location:

SERVO BOARD (A) (DECK side)

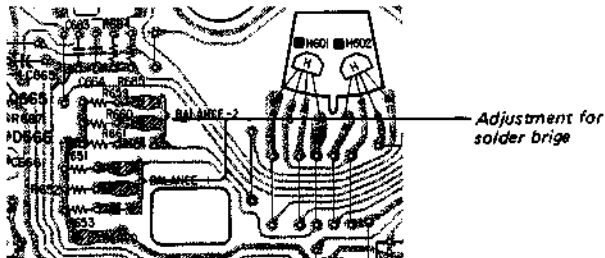

SERVO BOARD (B) (DECK side)

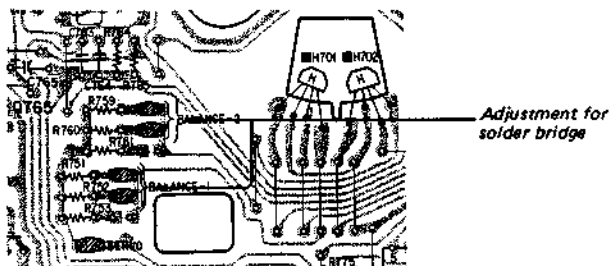

5-3. RECORD/PLAYBACK HEAD AZIMUTH ADJUSTMENT

DECK A/DECK B

Setting:

VOLUME control: mechanical mid

Procedure:

1. Mode: playback
TAPE SPEED switch: 2.4 cm
Channels: 1 and 4

test tape
P-4-A100
(10 kHz, -10 dB)

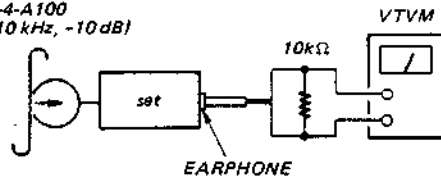

2. Turn the adjustment screw for the highest VTVM reading.
Note: Several peaks may appear, take the highest. Level difference between CH1 and CH4 should be within 0.5 dB.
3. After the adjustment, lock the adjustment screw with a suitable locking compound.

Adjustment Location:

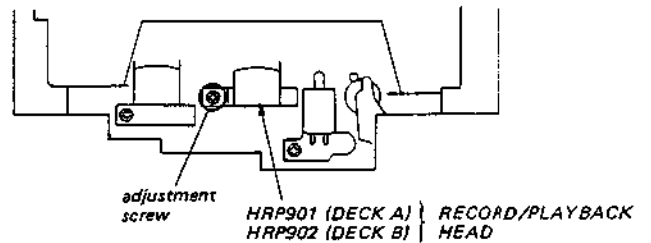

5-4. MONITOR HEAD AZIMUTH ADJUSTMENT

DECK A/DECK B

Setting:

Mode: record/simultaneous monitoring
TAPE SPEED switch: 2.4 cm
Channels: 1 and 4

AF OSC

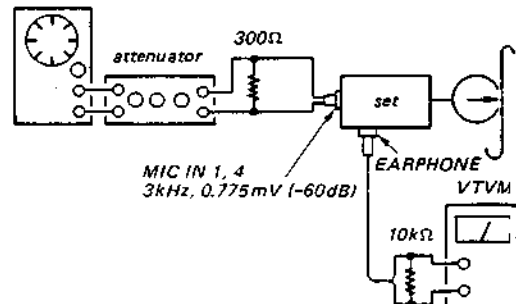

Procedure:

1. Set MONITOR CHANNEL SELECT switch to CH1.
2. Set MONITOR switch to SOURCE.

3. Set VOLUME control to obtain a 0.25 V(-10dB) VTVM reading.
4. Set MONITOR switch to TAPE.
5. Adjust adjustment screw to obtain a maximum VTVM reading. Set adjustment screw while adjusting in the clockwise direction.
6. Set MONITOR CHANNEL SELECT switch to CH4 and make sure the maximum output at CH4. Level difference between channels land 4 should be within 1 dB.
7. Fix adjustment screw with locking compound after adjustment.

Adjustment Location:

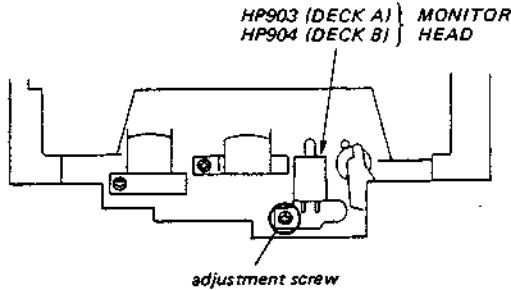

5.5. TAPE MONITOR LEVEL ADJUSTMENT

DECK A/DECK B

Setting:

Mode: record/simultaneous monitoring
TAPE SPEED switch: 2.4 cm and 1.2 cm
Channels: All

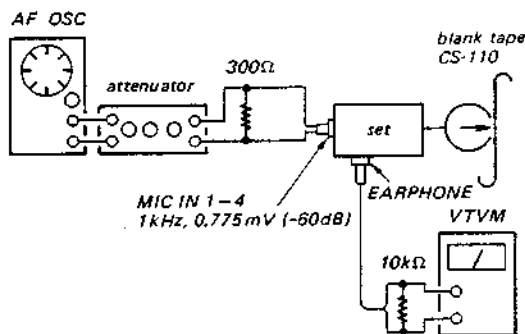

Procedure:

1. Set MONITOR switch to SOURCE.
2. Adjust VOLUME control to obtain a 0.775V (0 dB) at EARPHONE output.
3. Set MONITOR switch to TAPE.
4. Adjust EARPHONE output level by opening/bridging adjustment patterns to obtain a 0.775 V (0 dB) output, or within 0 ± 3 dB from SOURCE.
5. Make sure of above outputs for both TAPE SPEEDS.

Adjustment Location: AUDIO BOARD

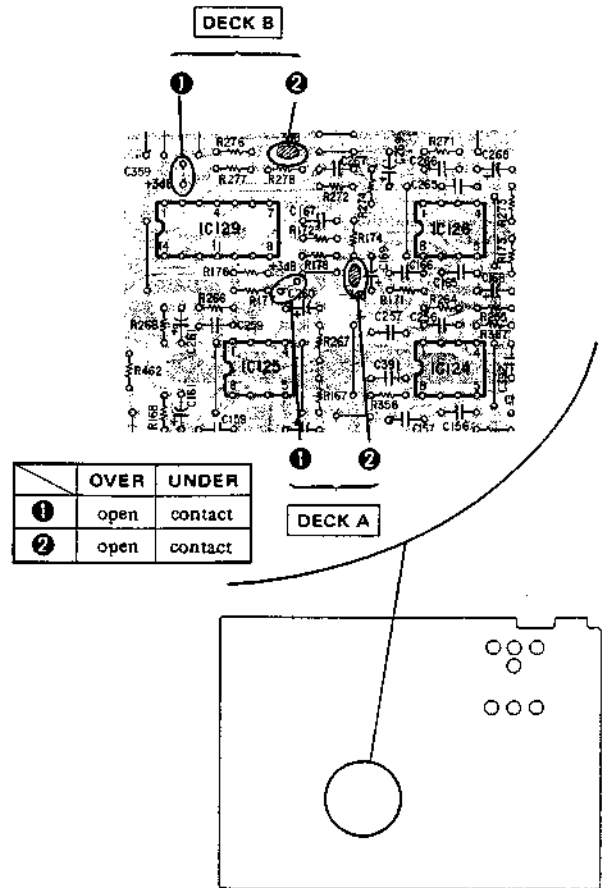

5.6. FREQUENCY RESPONSE CHECK AND RECORD BIAS ADJUSTMENT

DECK A/DECK B

Setting:

TONE control: max. H
TAPE SPEED switch: 2.4 cm

Procedure:

1. Mode: record

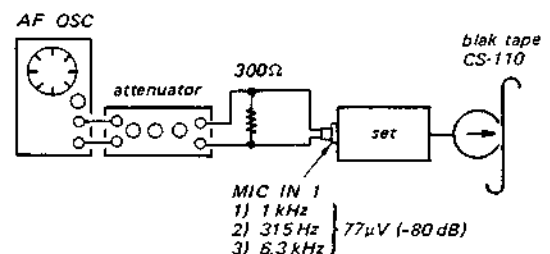

2. Mode: playback

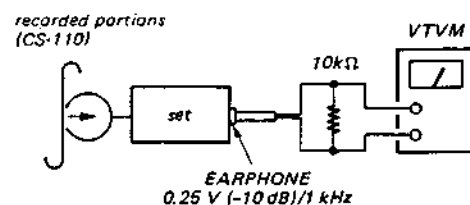

Recorded signals	VTVM reading
1 kHz	Adjust the VOLUME control for 0.25 V (-10 dB)
315 Hz	+1 dB
6.3 kHz	-7 dB

3. Playback both 315 Hz and 6.3 kHz signals. Output levels of them should be within 6 dB and 8 dB with respect to the that of 1 kHz signal.
4. Adjust higher-signal output level by opening/solder-bridging adjustment patterns shown below and repeating steps 1-3 above.
5. Check for all other channels.

Adjustment Location: AUDIO BOARD

Pattern Connection	6.3 kHz Signal Output Level
(A)	down
(B)	↑
(C)	up

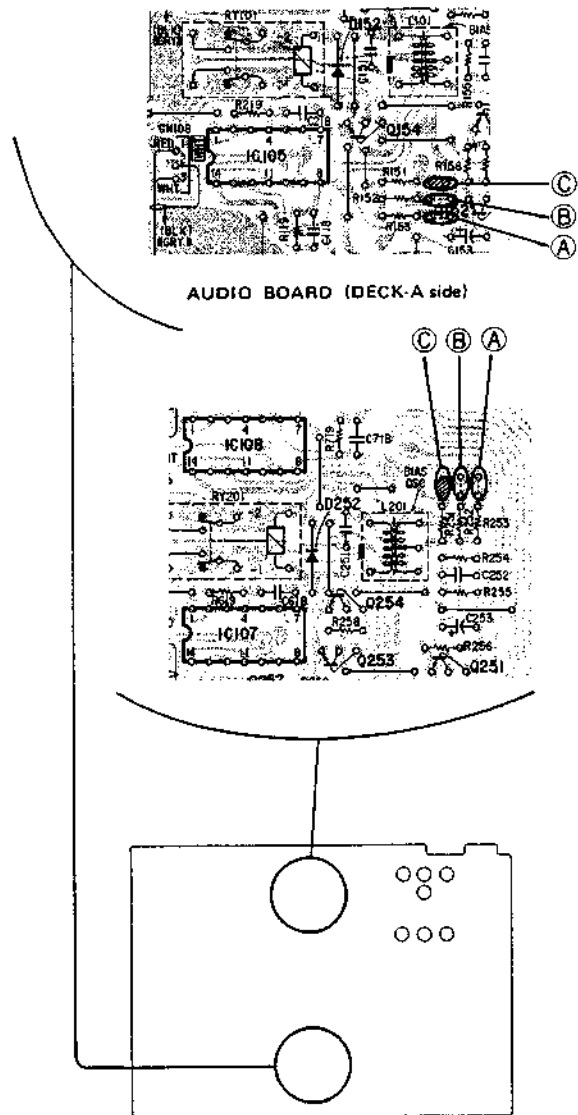

5-7. RECORD INHIBIT HEAD AZIMUTH ADJUSTMENT [DECK A/DECK B]

Setting:

TAPE SPEED switch: 2.4 cm

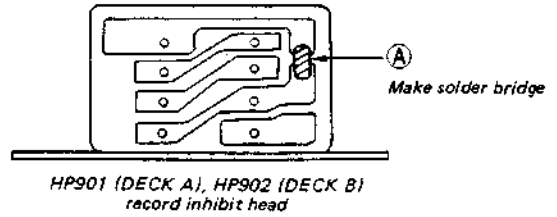

Procedure:

1. Mode: playback

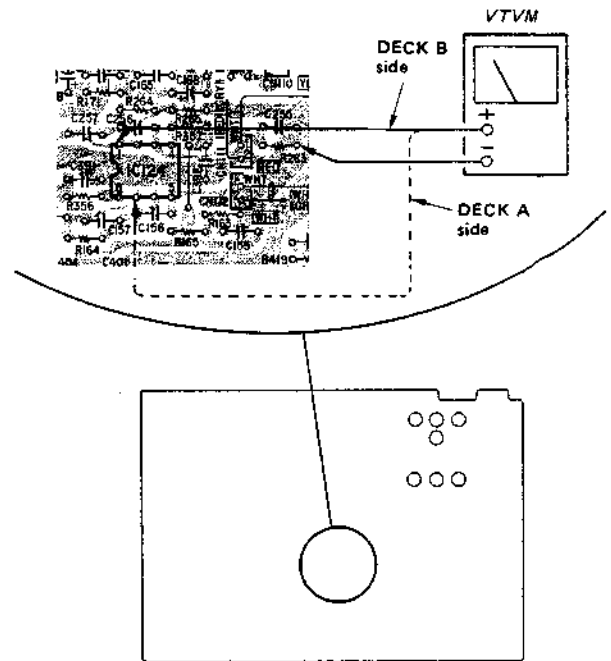
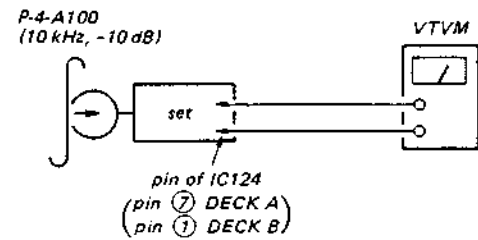

2. Adjust adjustment screw to obtain a maximum output. Adjustment should finish with a clockwise direction of adjustment. Lock adjustment screw with locking compound after adjustment.
3. After the adjustment, remove the (A) solder bridge.

Adjustment Location:

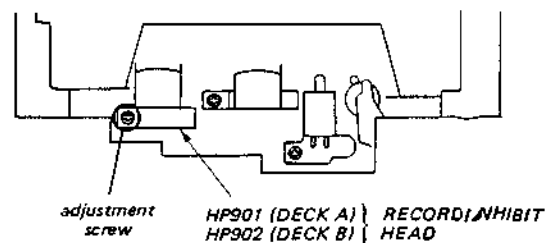

SECTION 6 DIAGRAMS

6-1. CIRCUIT BOARDS LOCATION

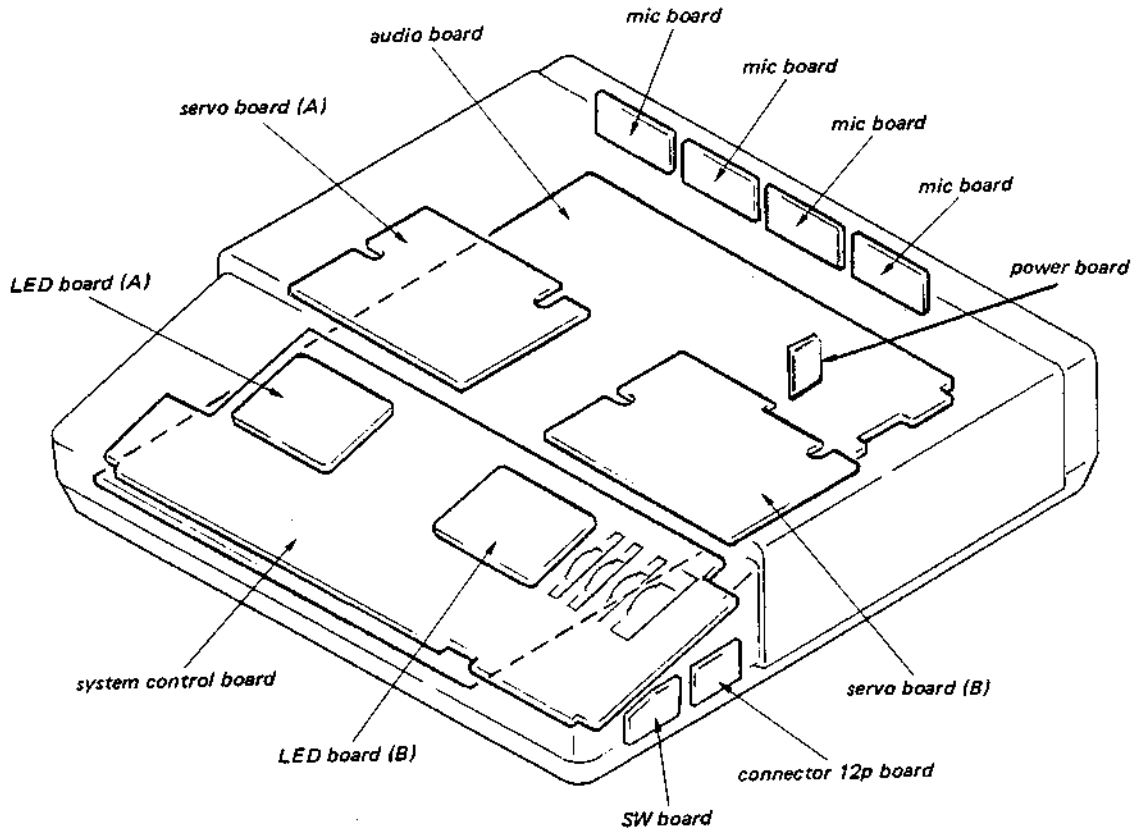

6-2. BLOCK DIAGRAM

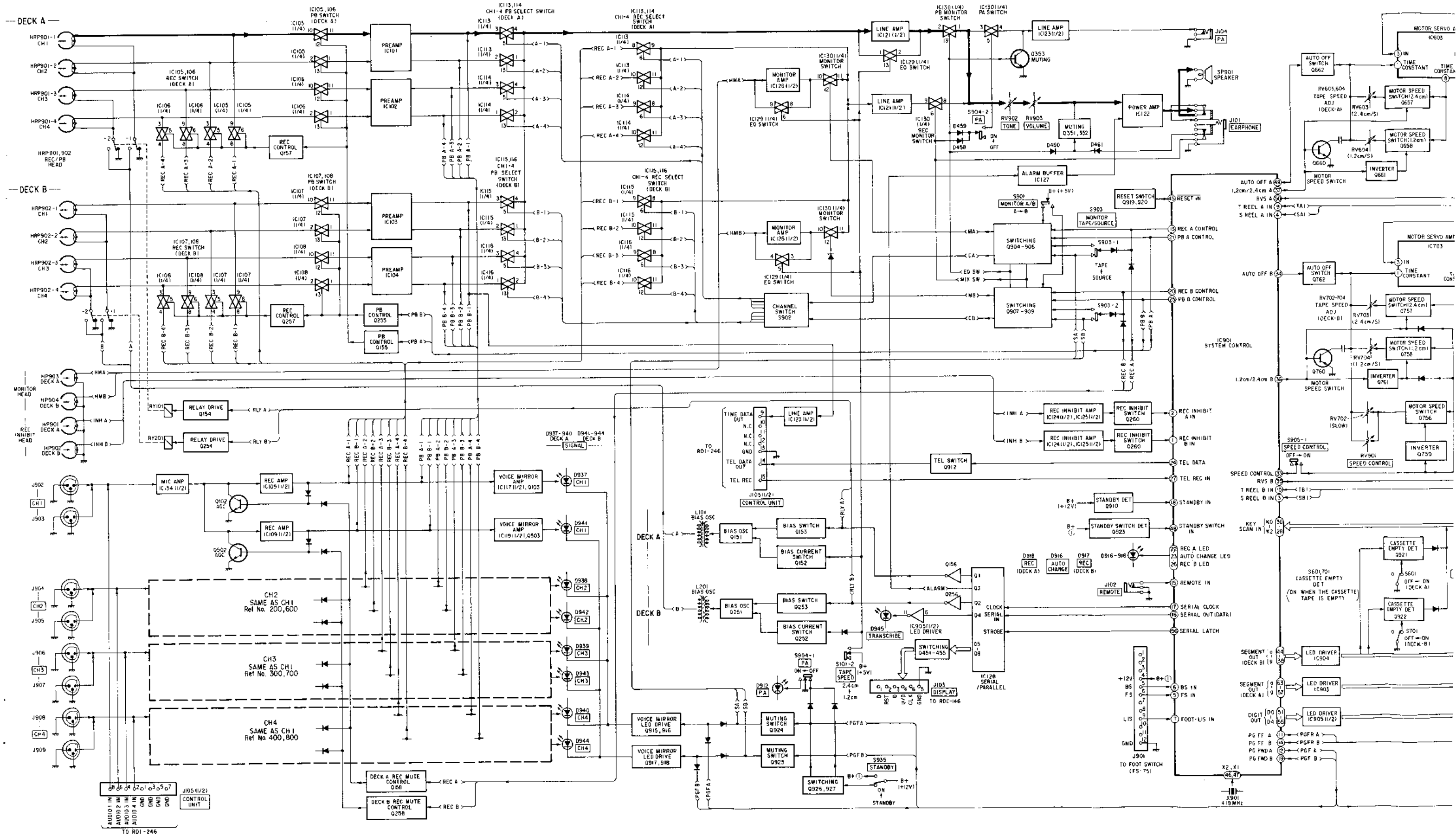

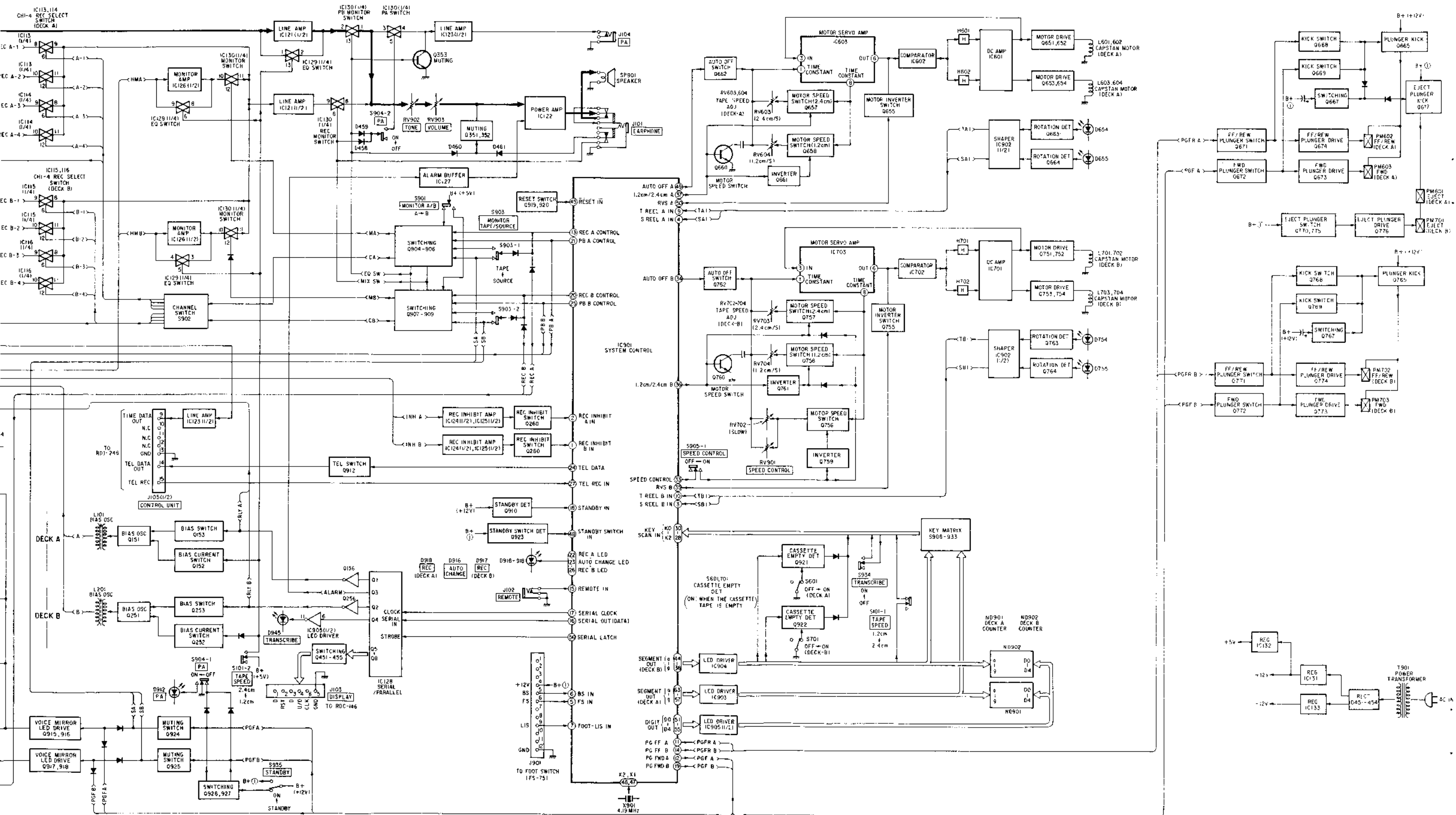

• Semiconductor Location

Ref. No.	Location	Ref. No.	Location	Ref. No.	Location
D651	E-20	D931	I-7	Q667	E-16
D654	C-17	D932	G-7	Q668	E-16
D655	C-20	D933	H-7	Q669	E-16
D656	E-17	D934	J-7	Q671	F-17
D658	F-17	D935	H-3	Q672	F-17
D659	C-16	D936	F-8	Q673	C-16
D660	B-16	D937	C-6	Q674	C-16
D661	B-16	D938	C-5	Q677	B-17
D662	A-19	D939	C-5	Q751	H-20
D663	B-16	D940	C-4	Q752	H-20
D664	D-16	D941	C-2	Q753	G-20
D665	A-18	D942	C-2	Q754	G-19
D666	D-17	D943	C-2	Q755	J-20
D751	J-20	D944	C-1	Q756	G-21
D752	G-20	D945	C-2	Q757	G-20
D753	G-21	D947	I-4	Q758	G-20
D754	H-17	D949	I-1	Q759	G-20
D755	H-20	D950	I-4	Q760	F-20
D756	J-17	D951	J-5	Q761	G-20
D757	J-17	D952	H-1	Q762	J-20
D758	K-16	D953	H-5	Q763	H-17
D759	I-16			Q764	H-20
D760	G-16	H601	D-18	Q765	I-17
D761	G-16	H602	D-19	Q767	I-16
D762	F-19	H701	I-18	Q768	J-16
D763	G-16	H702	I-19	Q769	J-16
D901	J-1			Q770	G-17
D902	I-1	ND901	B-5	Q771	J-17
D903	I-1	ND902	B-2	Q772	J-17
D904	I-1			Q773	H-16
D905	I-2	IC601	D-20	Q774	H-16
D906	J-1	IC602	E-19	Q775	G-17
D907	J-2	IC603	F-20	Q776	G-17
D908	J-3	IC701	I-20	Q904	I-3
D909	J-2	IC702	J-19	Q905	I-2
D910	J-4	IC703	K-20	Q906	I-2
D911	J-4	IC901	H-10	Q907	I-3
D912	F-3	IC902	H-6	Q908	I-2
D913	G-4	IC903	G-11	Q909	I-2
D914	G-5	IC904	G-10	Q910	J-12
D916	H-13	IC905	G-11	Q912	J-5
D917	I-6			Q915	G-5
D918	I-11	Q651	C-20	Q916	G-4
D919	G-9	Q652	C-20	Q917	G-5
D920	H-9	Q653	B-20	Q918	G-5
D921	H-8	Q654	B-20	Q919	H-12
D922	J-10	Q655	D-20	Q920	H-12
D923	J-11	Q657	B-20	Q921	F-10
D924	J-9	Q658	B-21	Q922	F-9
D925	H-7	Q660	A-20	Q923	J-12
D926	F-12	Q661	B-20	Q924	G-4
D927	J-13	Q662	F-21	Q925	H-4
D928	F-12	Q663	C-17	Q926	H-4
D929	G-8	Q664	C-20	Q927	H-4
D930	H-5	Q665	D-17		

- Note:
- Color code or sleeving over the end of the jacket.
 - (RED/CHEV) : parts extracted from the component side.
 - : parts extracted from the conductor side.
 - : parts mounted on the conductor side.
 - : Through hole.
 - : Pattern on the side which is seen.
 - : Pattern of the rear side.
 - **WHT** : Connector color.

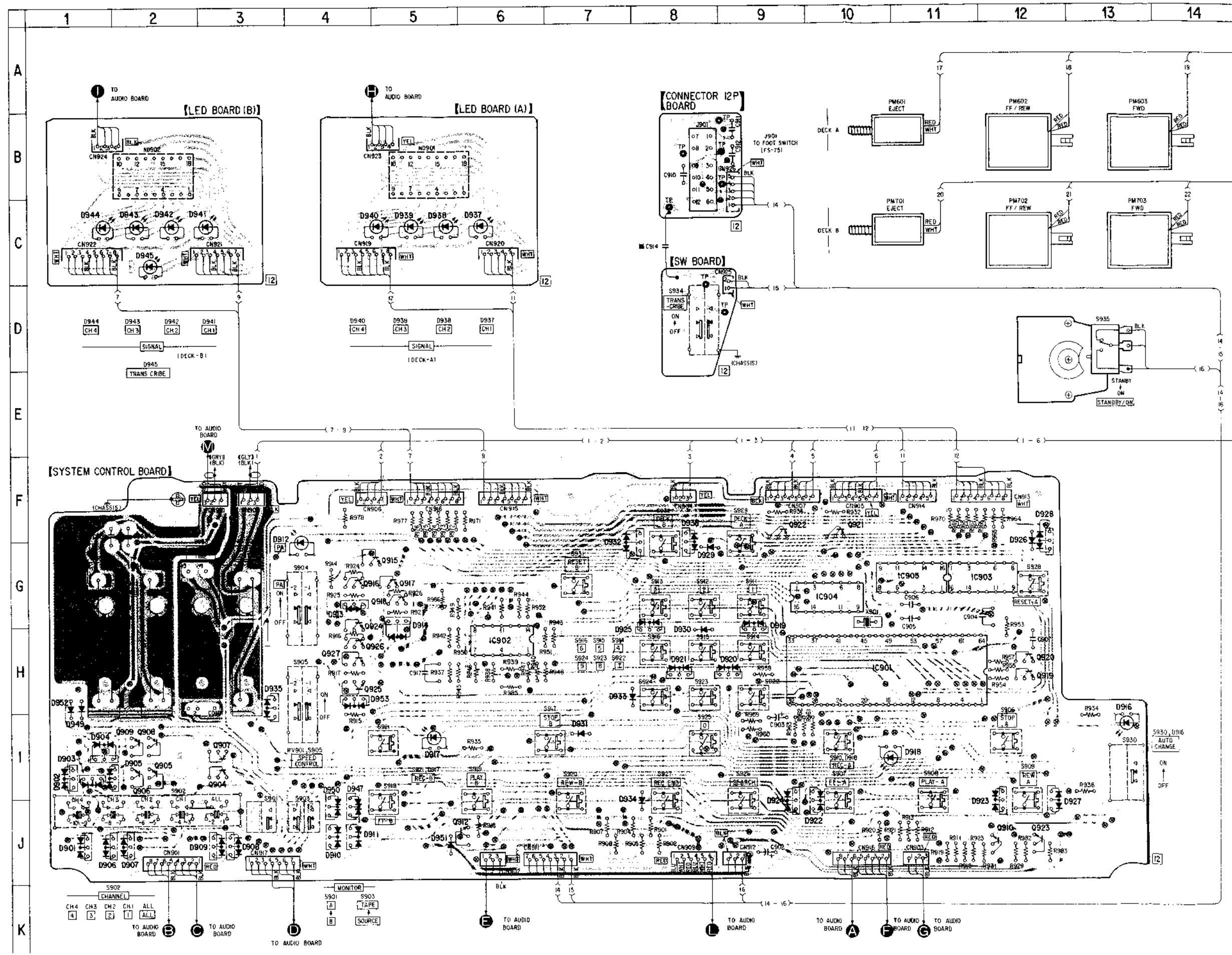

- See page 26 for circuit boards location.
- See page 39 for semiconductor lead layouts.

-SERVO CONTROL SECTION-

5	6	7	8	9	10	11	12	13	14	15	16	17	18	19	20	21
---	---	---	---	---	----	----	----	----	----	----	----	----	----	----	----	----

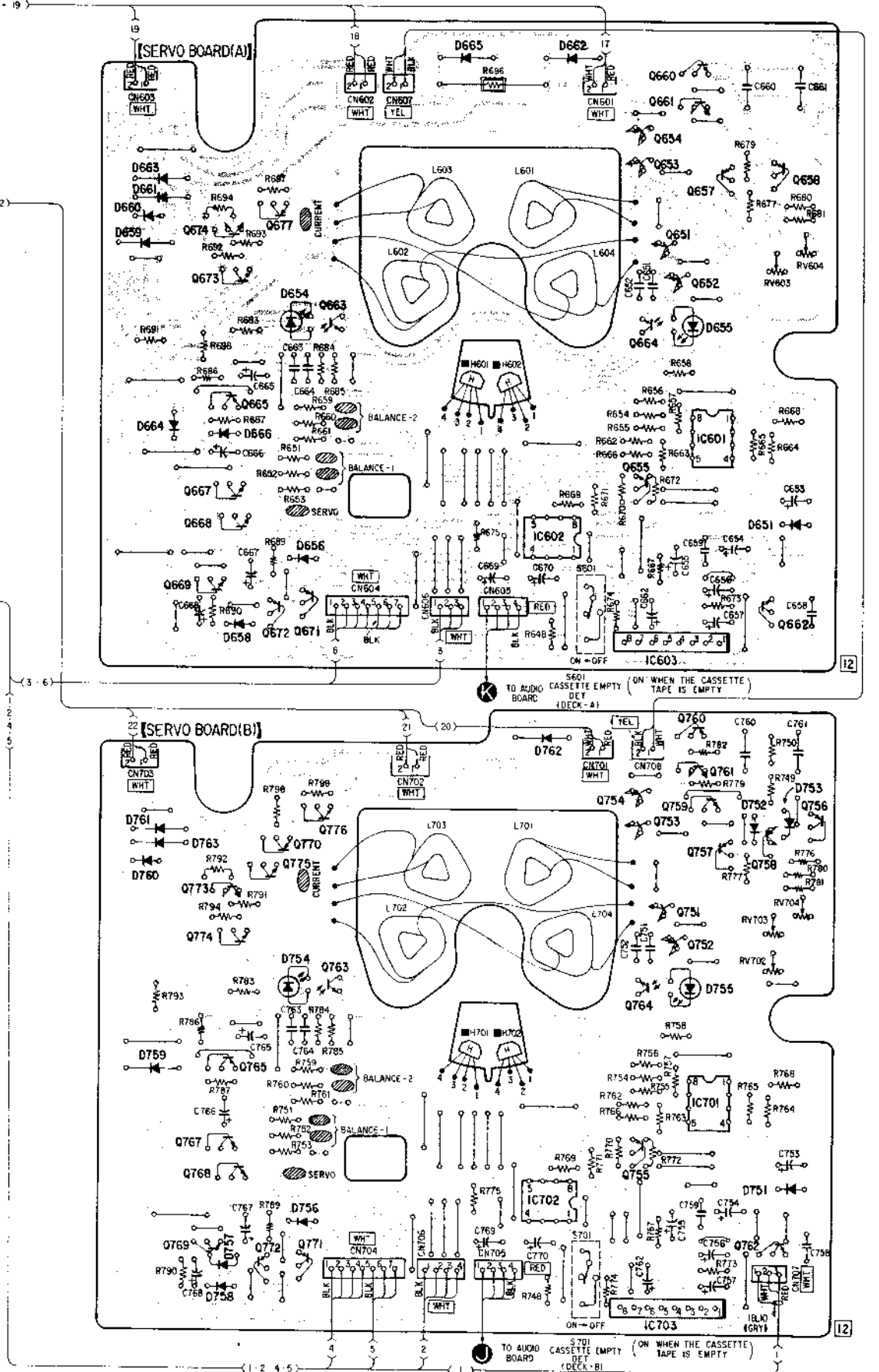
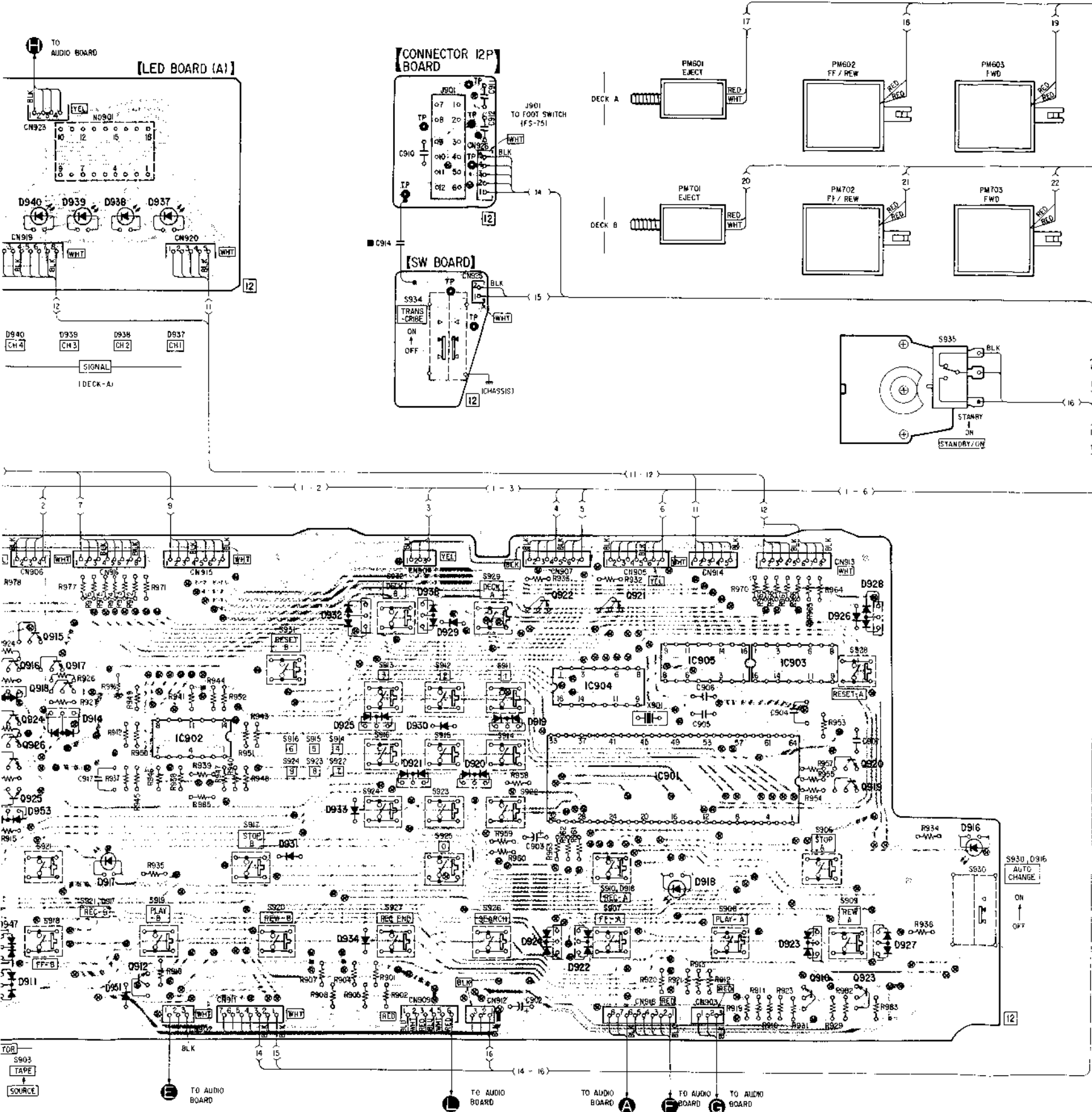

6-4. SCHEMATIC DIAGRAM (1) • See page 38 for switches note.

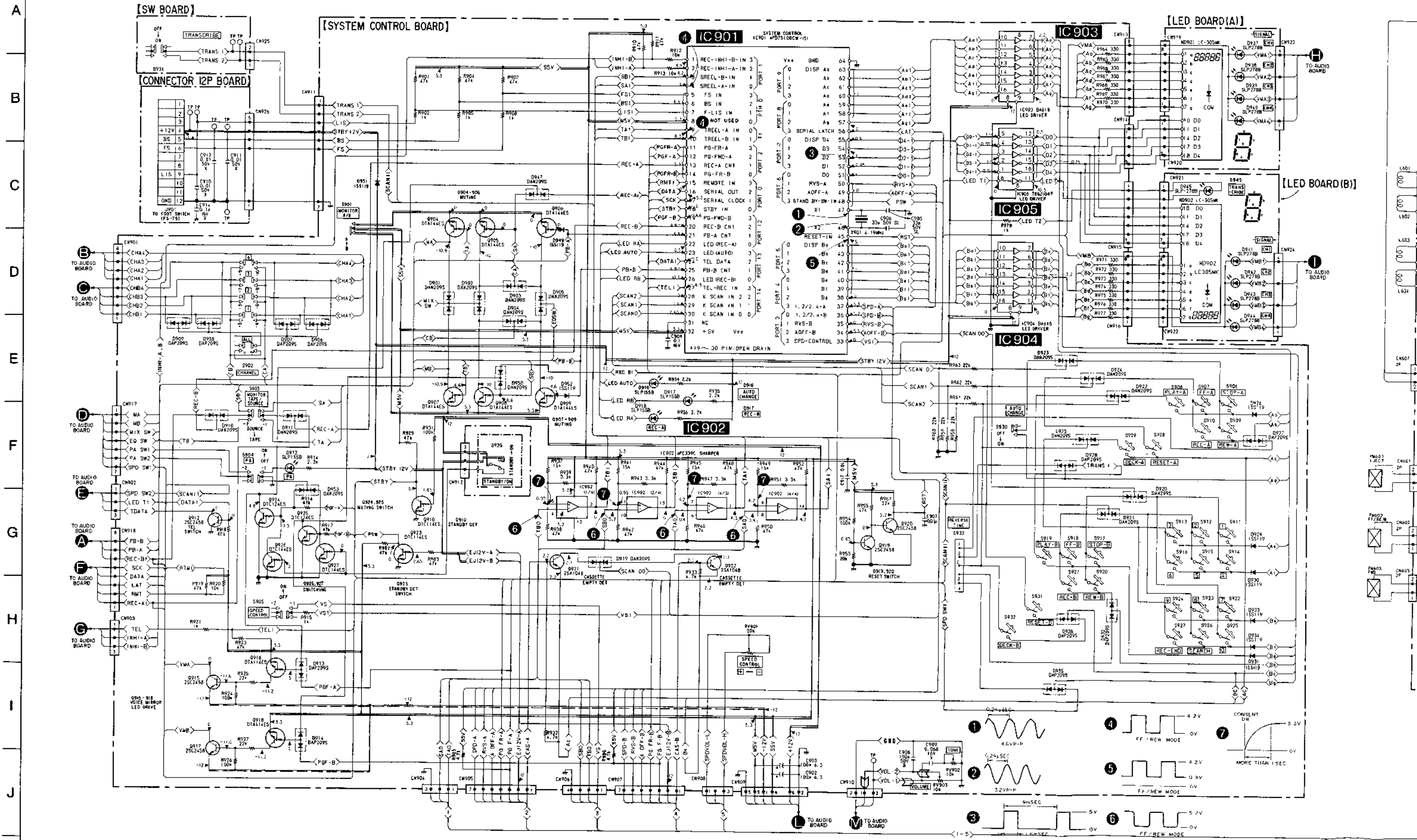

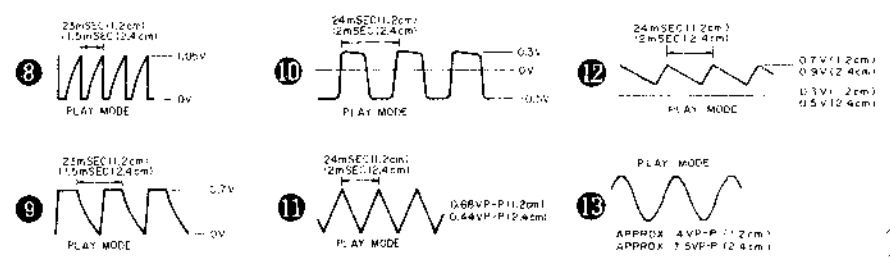
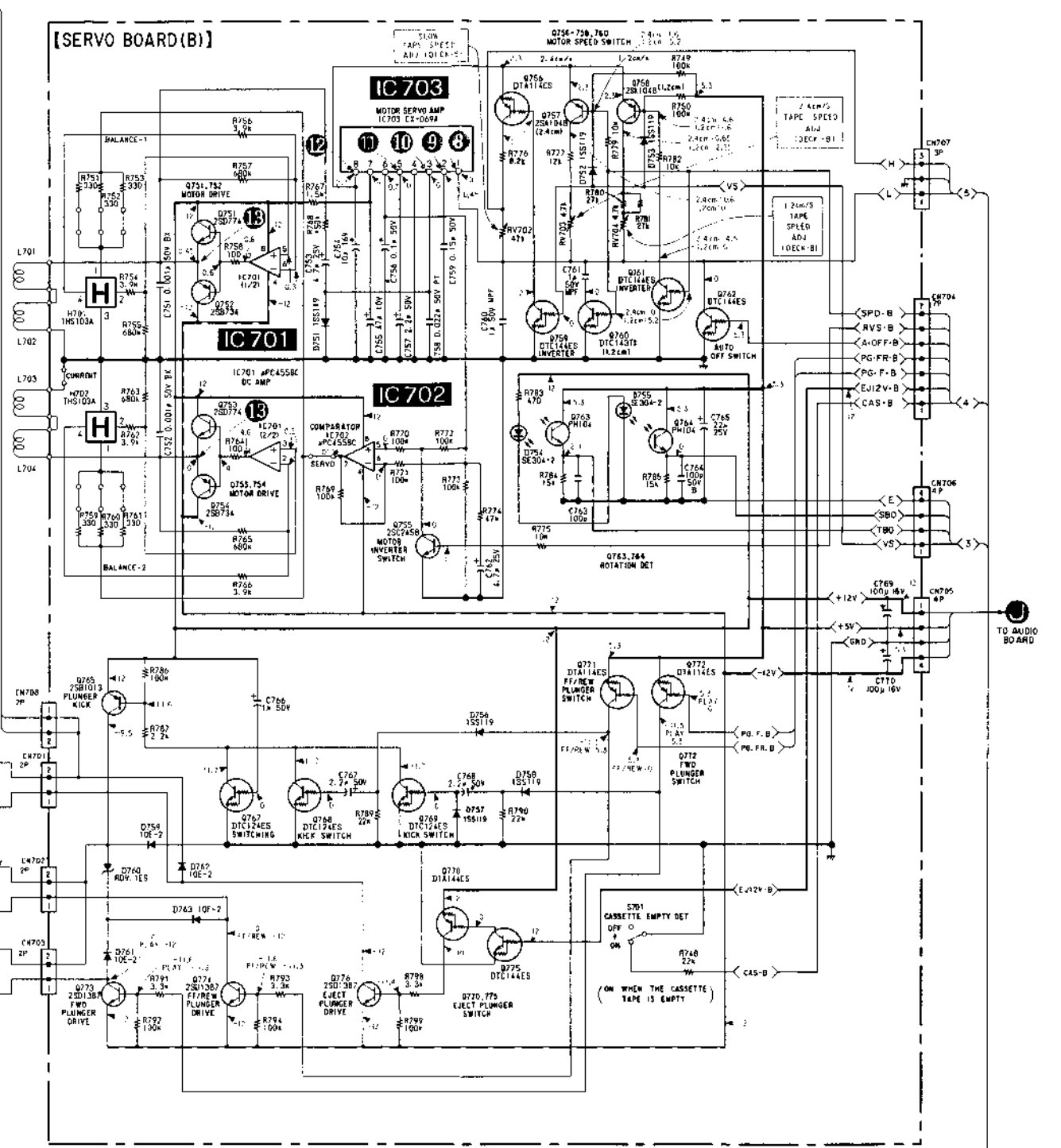
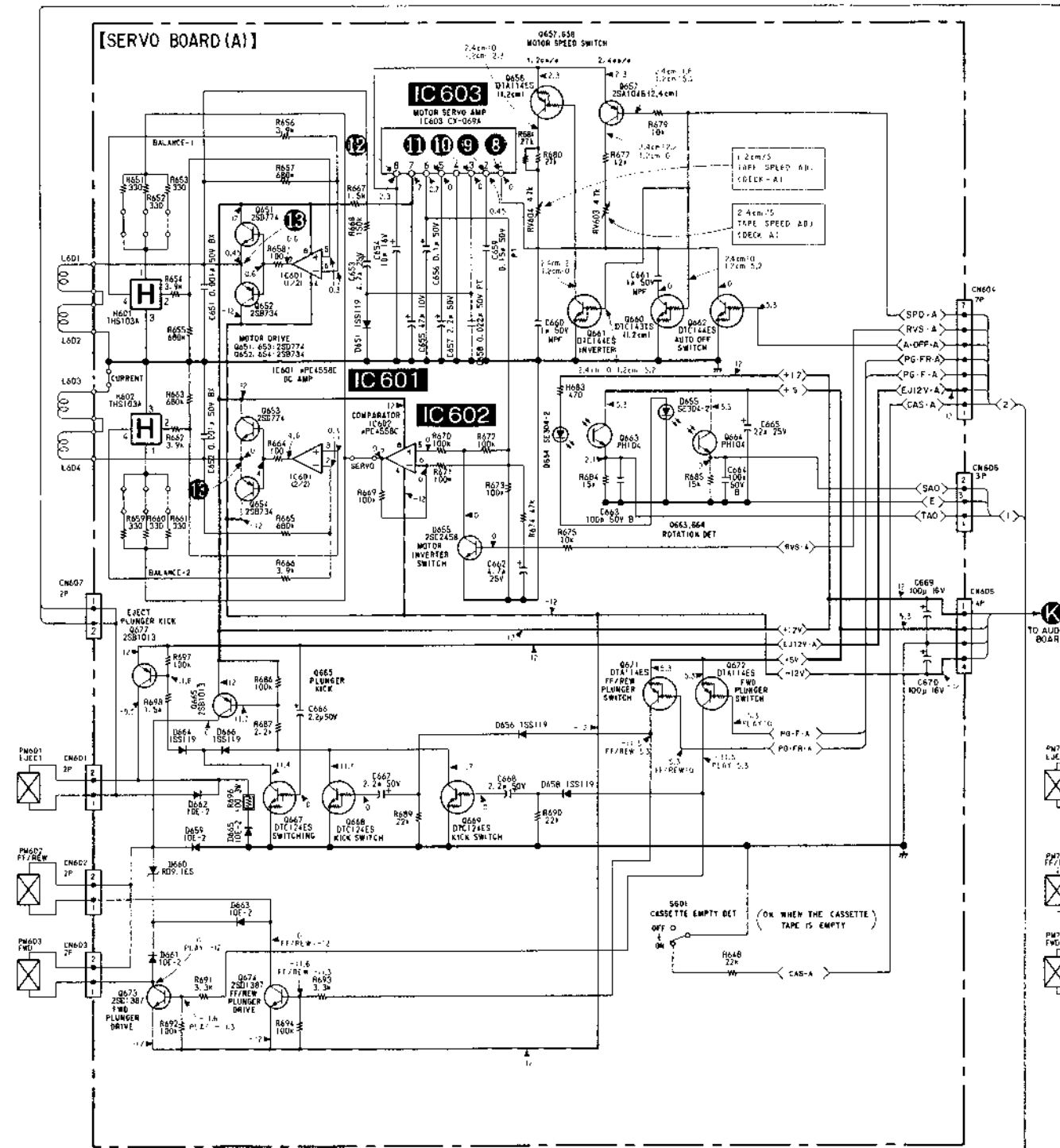
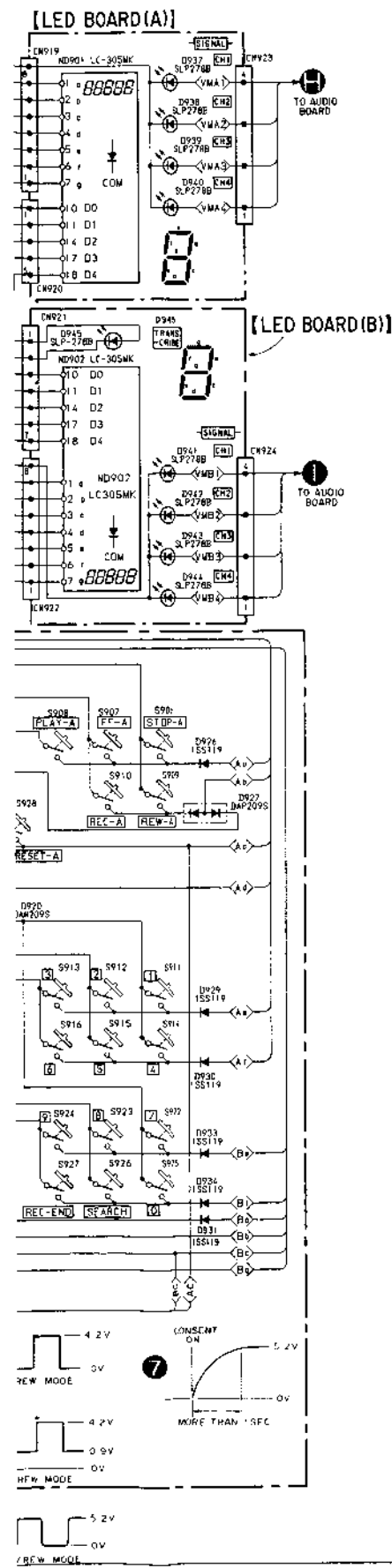

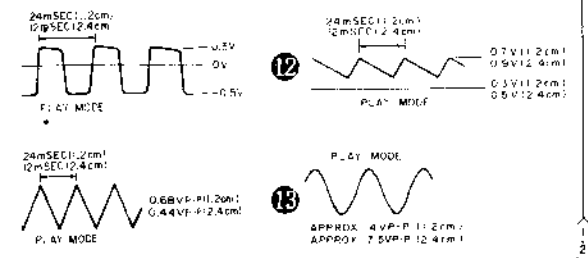
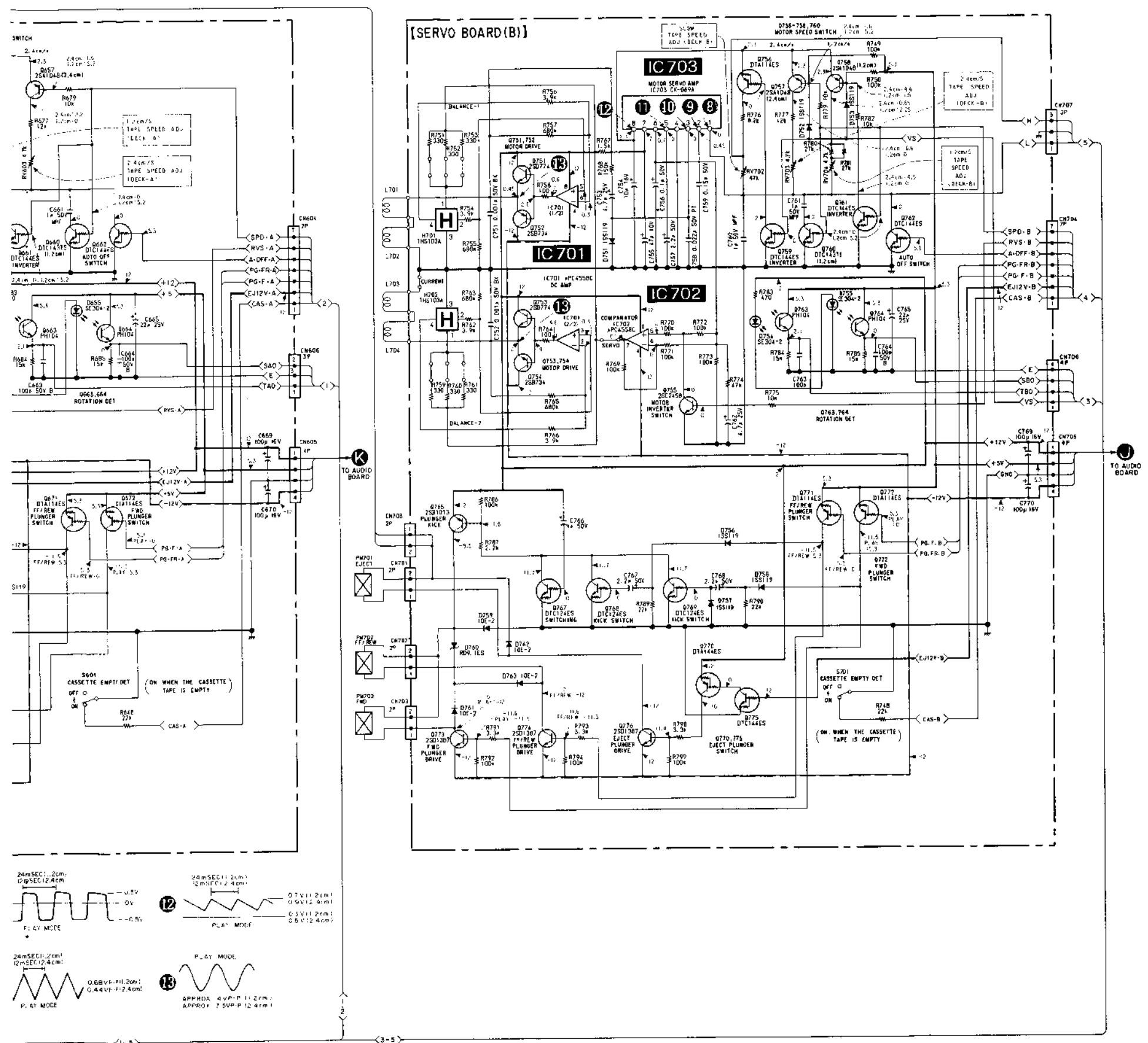

A
B
C
D
E
F
G
H
I
J
K

- Note:
- All capacitors are in μF unless otherwise noted. pF : μF 50WV or less are not indicated except for electrolytics and tantalums.
 - All resistors are in Ω and $1/4\text{W}$ or less unless otherwise specified.
 - : nonflammable resistor.
 - : B+ bus.
 - : B- bus.
 - : adjustment for repair.
 - Voltage and waveforms are dc with respect to ground under no-signal conditions.
no mark: STOP mode
 - Voltages are taken with a VOM (50 $\text{k}\Omega/\text{V}$). Voltage variations may be noted due to normal production tolerances.
 - Waveforms are taken with an oscilloscope. Voltage variations may be noted due to normal production tolerances.
 - Signal path.
 : PB (DECK A)

*See page 38 for switches note.

- IC BLOCK DIAGRAM
IC603, 703 CX-069A

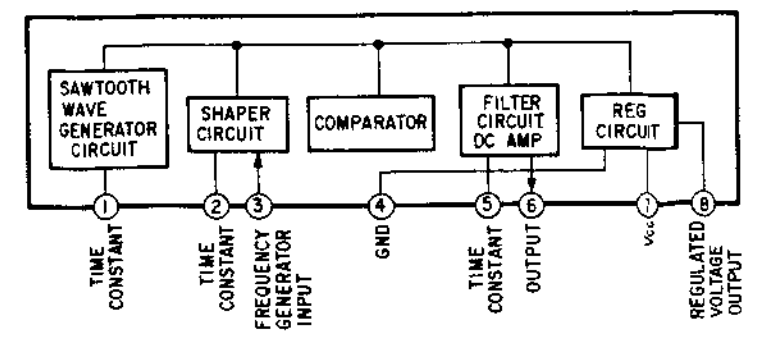

• Switches note (SERVO CONTROL SECTION)

Ref. No.	Switch	Position
S601	CASSETTE EMPTY DET (DECK A)	ON
S701	CASSETTE EMPTY DET (DECK B)	ON
S901	MONITOR A/B	B
S902-1, -2	CHANNEL ALL	OFF
S902-3, -4	CHANNEL 1	OFF
S902-5, -6	CHANNEL 2	OFF
S902-7, -8	CHANNEL 3	OFF
S902-9, -10	CHANNEL 4	OFF
S903	MONITOR TAPE/SOURCE	SOURCE
S904	PA	OFF
S905	SPEED CONTROL	OFF
S906	STOP-A	OFF
S907	FF-A	OFF
S908	PLAY-A	OFF
S909	REW-A	OFF
S910	REC-A	OFF
S911	1	OFF
S912	2	OFF
S913	3	OFF
S914	4	OFF
S915	5	OFF
S916	6	OFF
S917	STOP-B	OFF
S918	FF-B	OFF
S919	PLAY-B	OFF
S920	REW-B	OFF
S921	REC-B	OFF
S922	7	OFF
S923	8	OFF
S924	9	OFF
S925	0	OFF
S926	SEARCH	OFF
S927	REC END	OFF
S928	RESET-A	OFF
S929	DECK-A	OFF
S930	AUTO CHANGE	OFF
S931	RESET-B	OFF
S932	DECK-B	OFF
S933	REVERSE TIME	-
S934	TRANSCRIBE	OFF
S935	STANDBY/ON	STANDBY

6-5. SEMICONDUCTORS LEAD LAYOUTS

<p>NJM4560D-D μPC393C μPC4558C</p>	<p>μPC575C2</p>	<p>μPC339C μPD4066BC</p>	<p>BA618 MSM4094RS TD62104P</p>	<p>μPD75108CW-151</p>	<p>CX-069A</p>
<p>TA78L006AP</p>	<p>NJM7812B</p>	<p>μPC7912H</p>	<p>2SB1013 2SD1387 2SD1388</p>	<p>2SB740</p>	<p>DTA114ES DTA144ES DTC114ES DTC124ES DTC143TS DTC144ES 2SC634SP 2SD1012</p>
<p>2SD774</p>	<p>PH104</p>	<p>ZSA1175</p>	<p>RD9.1ES-B 1SS119</p>	<p>10E2</p>	<p>THS103A</p>
<p>DAP209S</p>	<p>DAN209S</p>	<p>SLP162B</p>	<p>SE304-2K</p>	<p>SLP278B</p>	<p>LC-305MK</p>

• Semiconductor Location

Ref. No.	Location	Ref. No.	Locat
D101	K-14	D601	H-1
D102	K-14	D602	H-1
D103	K-13	D603	H-1
D104	I-5	D604	C-4
D105	I-4	D605	D-4
D151	J-11	D701	G-1
D152	I-10	D702	G-1
D153	G-5	D703	G-1
D154	G-5	D704	B-5
D201	I-13	D705	C-4
D202	I-13	D801	F-1
D203	I-13	D802	F-1
D204	I-4	D803	F-1
D205	I-4	D804	B-4
D251	D-11	D805	B-5
D252	B-10		
D253	G-6	IC101	J-8
D254	G-5	IC102	I-8
		IC103	C-8
		IC104	B-8
D301	H-13	IC105	J-10
D302	H-13	IC106	I-10
D303	H-13	IC107	C-10
D304	H-5	IC108	B-10
D305	H-4	IC109	J-10
D351	E-5	IC110	I-10
D352	D-8	IC111	H-10
D353	E-7	IC112	G-11
D401	G-13	IC113	I-7
D402	G-13	IC114	H-7
D403	G-13	IC115	C-7
D404	H-4	IC116	B-7
D405	G-5	IC117	I-5
D451	B-15	IC118	H-5
D452	B-15	IC119	D-5
D453	B-15	IC120	B-5
D454	B-15	IC121	F-6
D455	D-13	IC122	E-10
D456	D-13	IC123	D-9
D458	F-4	IC124	H-9
D459	F-4	IC125	H-8
D460	F-5	IC126	G-9
D461	F-5	IC127	E-6
D501	J-14	IC128	D-4
D502	J-14	IC129	G-7
D503	J-13	IC130	D-7
D504	D-5	IC131	C-15
D505	D-4		

Note.

- Color code or sleeving

- ○ : parts extracted
- ● : parts extracted
- □ : indicates side ic
- ▨ : Pattern on the
- WHT : Connector co

6-6. PRINTED WIRING BOARDS (2) —Conductor Side—
 • See page 26 for circuit boards location.

• Semiconductor Location

Ref. No.	Location	Ref. No.	Location	Ref. No.	Location
D101	K-14	D601	H-14	IC132	D-13
D102	K-14	D602	H-14	IC133	C-13
D103	K-13	D603	H-13	IC134	I-14
D104	I-5	D604	C-4	IC135	H-14
D105	I-4	D605	D-4		
D151	J-11	D701	G-14	Q102	K-14
D152	I-10	D702	G-14	Q103	J-5
D153	G-5	D703	G-13	Q151	I-11
D154	G-5	D704	B-5	Q152	J-11
D201	I-13	D705	C-4	Q153	J-11
D202	I-13	D801	F-14	Q154	J-10
D203	I-13	D802	F-14	Q155	H-10
D204	I-4	D803	F-12	Q156	I-11
D205	I-4	D804	B-4	Q157	H-10
D251	D-11	D805	B-5	Q158	H-11
D252	B-10			Q160	G-5
D253	G-6	IC101	J-8	Q202	I-14
D254	G-5	IC102	I-8	Q203	I-5
		IC103	C-8	Q251	C-11
D301	H-13	IC104	B-8	Q252	D-11
D302	H-13	IC105	J-10	Q253	C-10
D303	H-13	IC106	I-10	Q254	C-10
D304	H-5	IC107	C-10	Q255	D-9
D305	H-4	IC108	B-10	Q256	E-10
D351	E-5	IC109	J-13	Q257	C-10
D352	D-8	IC110	I-13	Q258	H-11
D353	E-7	IC111	H-13	Q260	F-5
D401	G-13	IC112	G-13	Q302	H-14
D402	G-13	IC113	I-7	Q303	H-5
D403	G-13	IC114	H-7	Q351	E-12
D404	H-4	IC115	C-7	Q352	E-12
D405	G-5	IC116	B-7	Q353	D-8
D451	B-15	IC117	I-5	Q402	G-14
D452	B-15	IC118	H-5	Q403	G-5
D453	B-15	IC119	D-5	Q451	F-15
D454	B-15	IC120	B-5	Q452	F-16
D455	D-13	IC121	F-6	Q453	F-16
D456	D-13	IC122	E-13	Q454	G-15
D458	F-4	IC123	D-9	Q455	F-15
D459	F-4	IC124	H-9	Q502	J-14
D460	F-5	IC125	H-8	Q503	D-5
D461	F-5	IC126	G-9	Q602	H-14
D501	J-14	IC127	E-6	Q603	C-5
D502	J-14	IC128	D-4	Q702	G-14
D503	J-13	IC129	G-7	Q703	C-5
D504	D-5	IC130	D-7	Q802	F-14
D505	D-4	IC131	C-15	Q803	B-5

Note.

- Color code or sleeving over the end of the jacket.

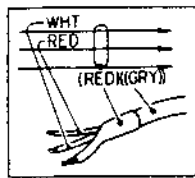

- —○— : parts extracted from the component side.
- —●— : parts extracted from the conductor side.
- □ : indicates side identified with part number.
- [Pattern] : Pattern on the side which is seen.
- WHT : Connector color.

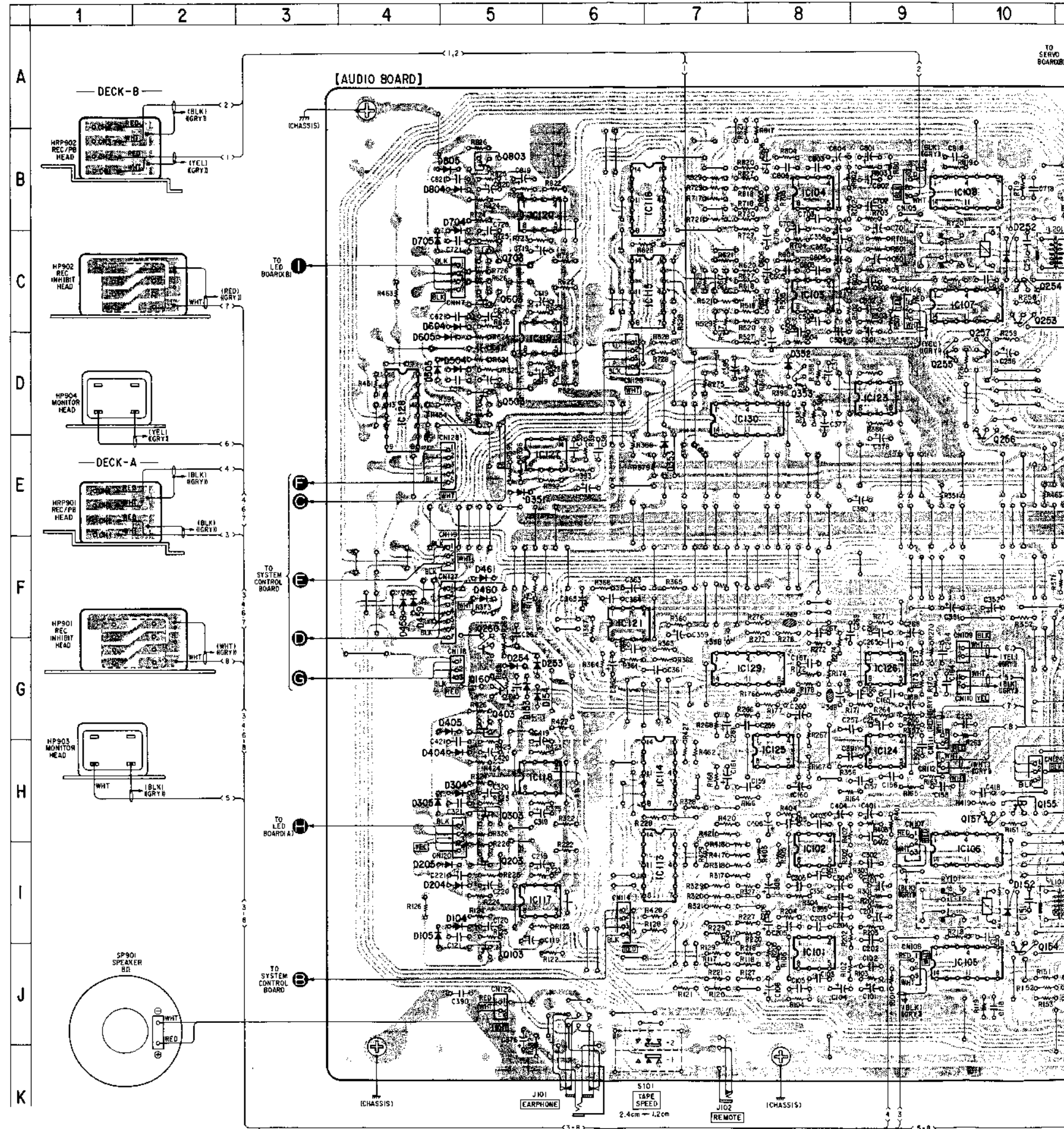

3 4 5 6 7 8 9 10 11 12 13 14 15 16 17 18 19

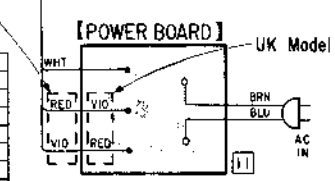
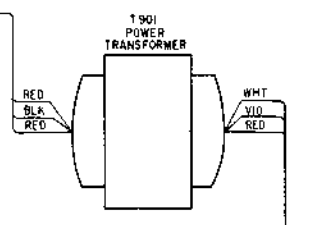
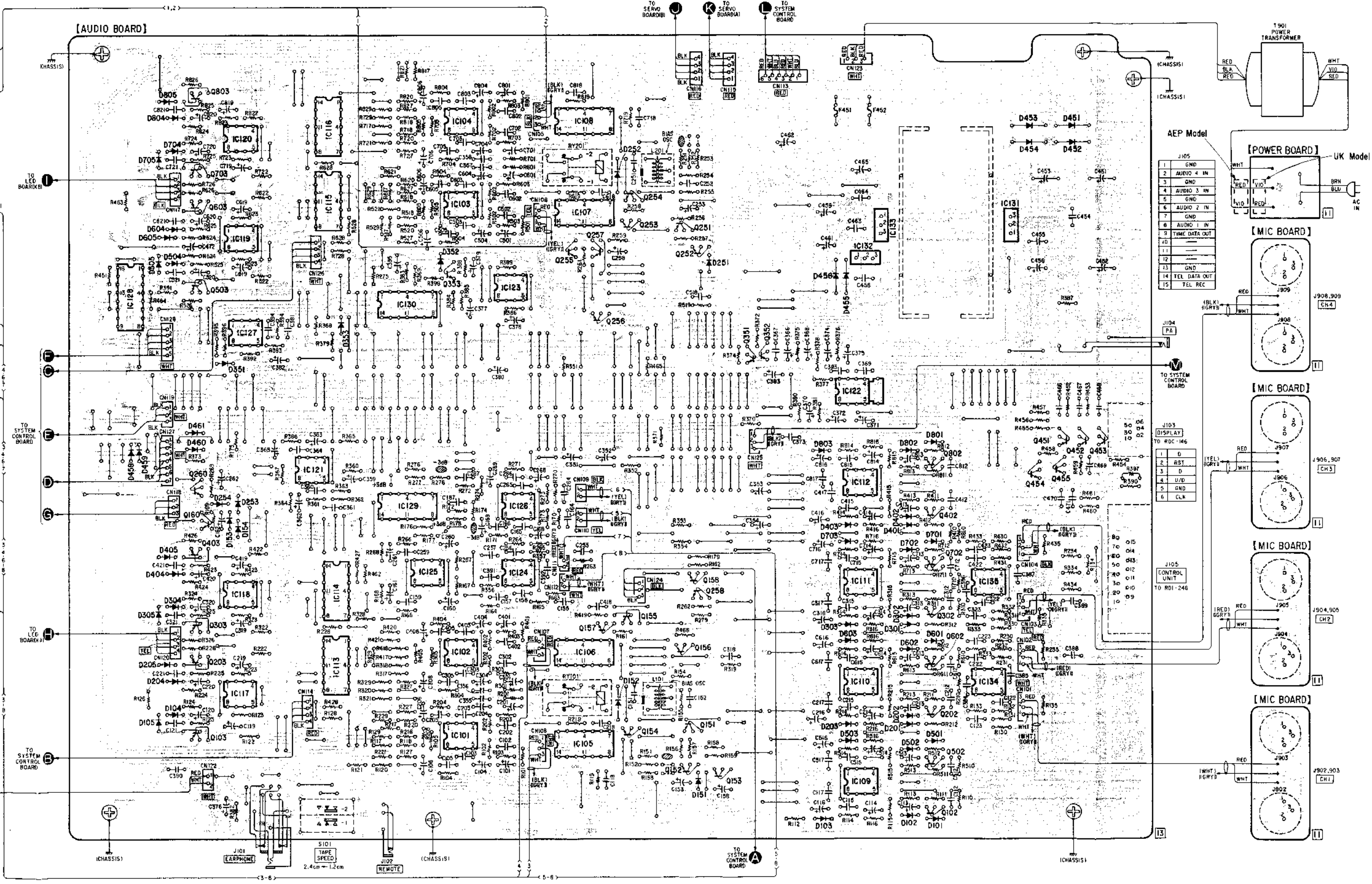

J105	1	2	3	4	5	6	7	8	9	10	11	12	13	14	15
	GND	AUDIO 4 IN	GND	AUDIO 3 IN	GND	AUDIO 2 IN	GND	AUDIO 1 IN	TIME DATA OUT	TEL DATA OUT	TEL REC				

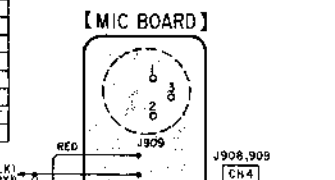

J103	1	2	3	4	5	6
DISPLAY	D	AST	U/D	GND	CLK	

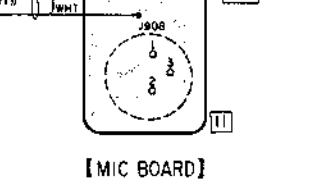

J105	1	2	3	4	5	6	7	8	9	10	11	12	13	14	15
CONTROL UNIT															

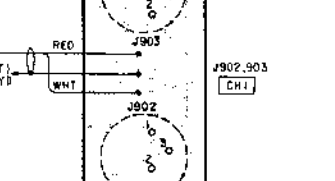
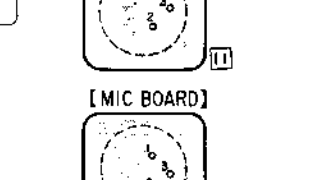
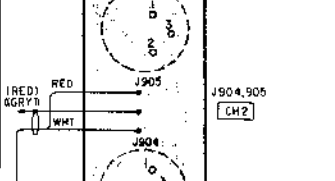
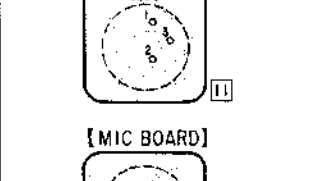
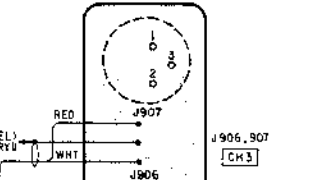

6-7. SCHEMATIC DIAGRAM (2)

• See page 46 for note.

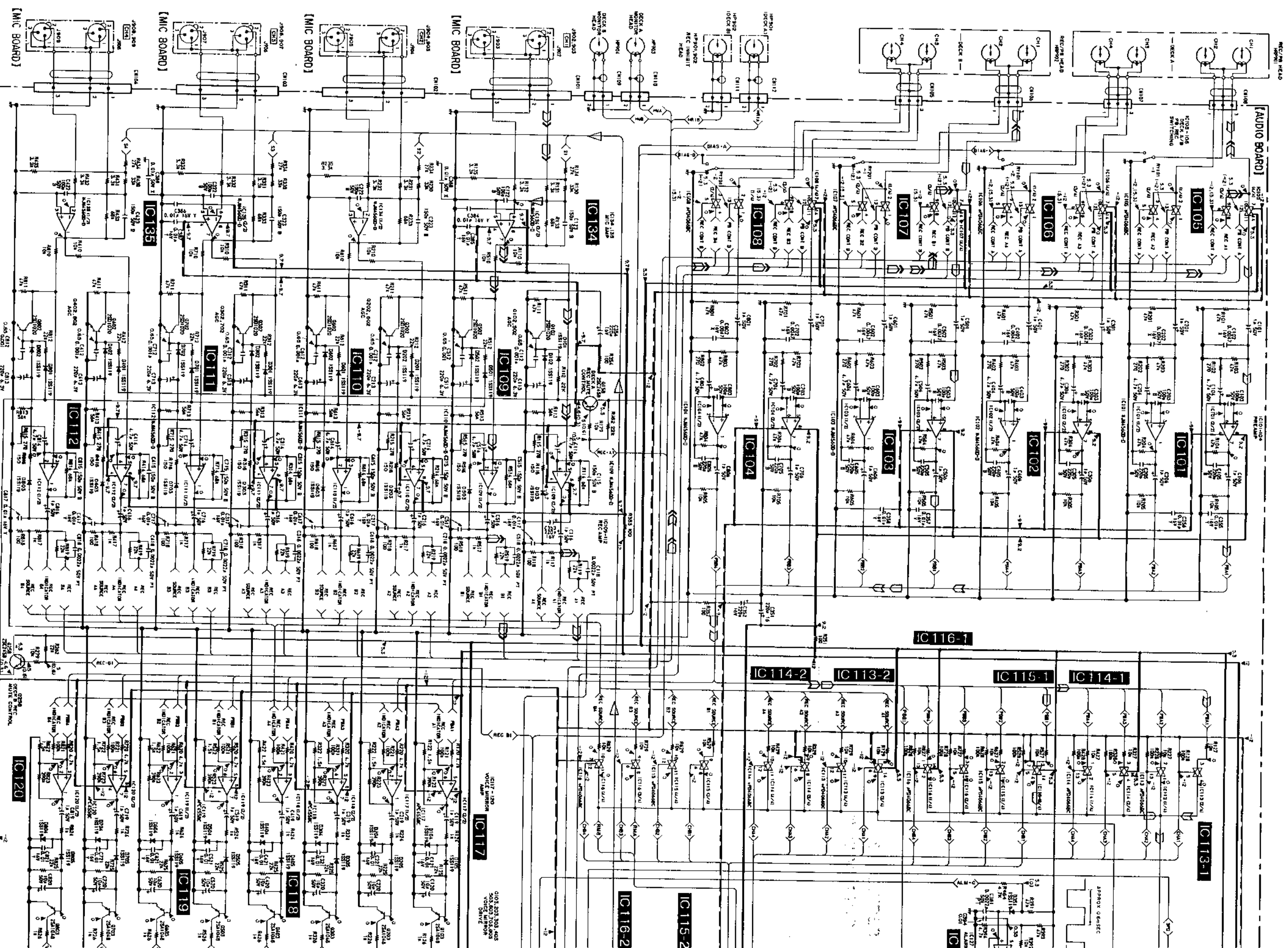

SECTION 7 EXPLODED VIEWS

7-2

NOTE:

- The mechanical parts with no reference number in the exploded views are not supplied.
- The construction parts of an assembled part are indicated with a collation number in the remark column.
- Items marked "*" are not stocked since they are seldom required for routine service. Some delay should be anticipated when ordering these items.

- Due to standardization, parts with part number suffix -XX and -X may be different from the parts specified in the components used on the set.
- Color Indication of Appearance Parts
Example:
(RED) ... KNOB, BALANCE (WHITE)
↑ Cabinet's Color ↑ Parts' Color

The components identified by mark or dotted line with mark are critical for safety. Replace only with part number specified.

Note:

- All capacitors are in μF unless otherwise noted. pF: $\mu\mu F$ 50WV or less are not indicated except for electrolytics and tantalums.
- All resistors are in Ω and $1/4W$ or less unless otherwise specified.
- : B+ bus.
- : B- bus.
- : adjustment for repair.
- Voltage and waveforms are dc with respect to ground under no-signal conditions.
- no mark: STOP mode (2.4 cm/s)
- () : REC (()) : REC TAPE MONITOR
- < > : PB << >> : PA ON
- [] : ALARM ([]) : 1.2 cm/s
- Voltages are taken with a VOM (50 k Ω/V). Voltage variations may be noted due to normal production tolerances.
- Waveforms are taken with an oscilloscope. Voltage variations may be noted due to normal production tolerances.
- Signal path.
- : PB (DECK A) (CHANNEL 1)
- : REC (DECK A) (CHANNEL 1)
- : PB (DECK B) (CHANNEL 1)
- : REC (DECK B) (CHANNEL 1)
- : PX (From RDI-246)

Switches:

Ref. No.	Switch	Position
S101	TAPE SPEED	1.2 cm

Note:
The components identified by mark or dotted line with mark are critical for safety. Replace only with part number specified.

7-1.

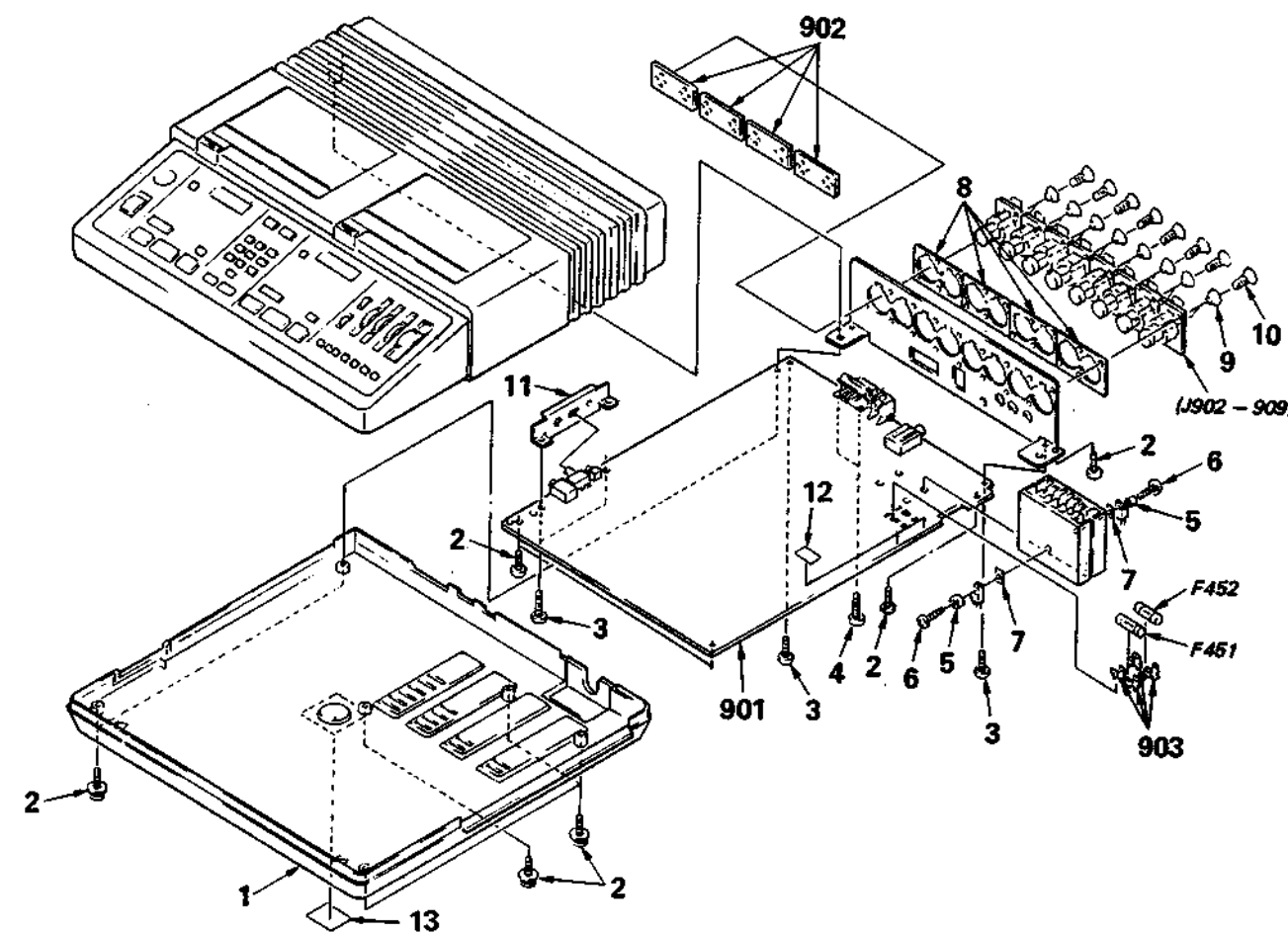

No.	Part No.	Description	Remarks	No.	Part No.	Description	Remarks	No.	Part No.	Description
1	X-3315-024-1	CABINET (REAR) ASSY		901	*A-3089-334-A	MOUNTED PCB, AUDIO		51	7-685-647-79	
2	7-682-949-09	SCREW +PSW 3X10		902	*1-625-939-11	PC BOARD, MIC		52	3-345-420-11	
3	7-682-147-01	SCREW +BVTT 3X6 (S)		903	*1-533-189-11	HOLDER, FUSE		53	3-669-480-21	
4	7-682-548-04	SCREW +B 3X8		F451	.1-532-259-00	FUSE, TIME-LAG (T1.6A)		54	3-703-358-04	
5	2-832-007-00	BUSHING (K), INSULATING		F452	.1-532-259-00	FUSE, TIME-LAG (T1.6A)		55	3-345-423-01	
6	7-628-254-20	SCREW +PS 2.6X8		J902	1-562-299-21	CONNECTOR (RECEPTACLE)(MIC CH1)		56	3-345-422-01	
7	4-875-726-00	SHEET, INSULATING		J903	1-562-299-21	CONNECTOR (RECEPTACLE)(MIC CH1)		57	X-3315-030-1	
8	3-345-438-01	SHEET, INSULATING		J904	1-562-299-21	CONNECTOR (RECEPTACLE)(MIC CH2)		58	3-845-110-00	
9	3-345-437-01	BUSHING, INSULATING		J905	1-562-299-21	CONNECTOR (RECEPTACLE)(MIC CH2)		59	7-682-661-09	
10	3-345-461-01	SCREW (+K) (2.6X6)		J906	1-562-299-21	CONNECTOR (RECEPTACLE)(MIC CH3)		60	3-556-081-00	
11	*3-345-433-01	PLATE, JACK		J907	1-562-299-21	CONNECTOR (RECEPTACLE)(MIC CH3)		62	7-623-508-01	
12	*3-701-948-16	LABEL (T1.6A), FUSE		J908	1-562-299-21	CONNECTOR (RECEPTACLE)(MIC CH4)		63	7-682-147-01	
13	*3-345-457-01	(UK)...LABEL, MODEL NUMBER (UK)		J909	1-562-299-21	CONNECTOR (RECEPTACLE)(MIC CH4)		64	7-685-647-79	
	*3-345-458-01	(AEP)...LABEL, MODEL NUMBER (AE)		S935	1-553-539-00	SWITCH, MICRO		65	3-345-417-01	
								66	7-621-775-80	

SECTION 7 EXPLODED VIEWS

NOTE:

- The mechanical parts with no reference number in the exploded views are not supplied.
- The construction parts of an assembled part are indicated with a collation number in the remark column.
- Items marked "*" are not stocked since they are seldom required for routine service. Some delay should be anticipated when ordering these items.

- Due to standardization, parts with part number suffix -XX and -X may be different from the parts specified in the components used on the set.
- Color Indication of Appearance Parts Example:
(RED) ... KNOB, BALANCE (WHITE)
↑ Cabinet's Color ↑ Parts' Color

The components identified by mark or dotted line with mark are critical for safety. Replace only with part number specified.

7-1.

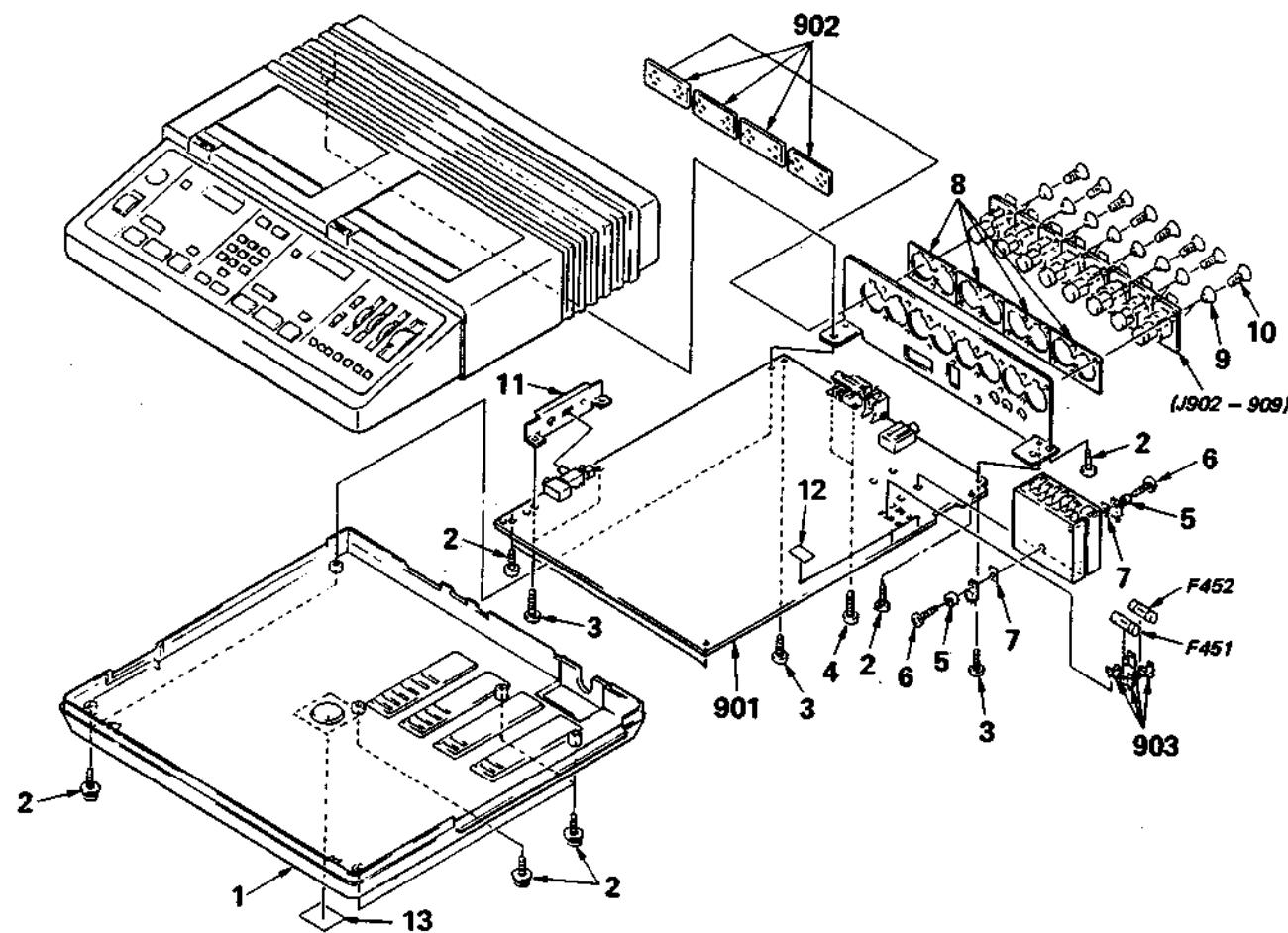

No.	Part No.	Description	Remarks	No.	Part No.	Description	Remarks
1	X-3315-024-1	CABIENT (REAR) ASSY		901	*A-3089-334-A	MOUNTED PCB, AUDIO	
2	7-682-949-09	SCREW +PSW 3X10		902	*1-625-939-11	PC BOARD, MIC	
3	7-682-147-01	SCREW +BVTY 3X6 (S)		903	*1-533-189-11	HOLDER, FUSE	
4	7-682-548-04	SCREW +B 3X8		F451	Δ.1-532-259-00	FUSE, TIME-LAG (T1.6A)	
5	2-832-007-00	BUSHING (K), INSULATING		F452	Δ.1-532-259-00	FUSE, TIME-LAG (T1.6A)	
6	7-628-254-20	SCREW +PS 2.6X8		J902	1-562-299-21	CONNECTOR (RECEPTACLE)(MIC CH1)	
7	4-875-726-00	SHEET, INSULATING		J903	1-562-299-21	CONNECTOR (RECEPTACLE)(MIC CH1)	
8	3-345-438-01	SHEET, INSULATING		J904	1-562-299-21	CONNECTOR (RECEPTACLE)(MIC CH2)	
9	3-345-437-01	BUSHING, INSULATING		J905	1-562-299-21	CONNECTOR (RECEPTACLE)(MIC CH2)	
10	3-345-461-01	SCREW (+K) (2.6X6)		J906	1-562-299-21	CONNECTOR (RECEPTACLE)(MIC CH3)	
11	*3-345-433-01	PLATE, JACK		J907	1-562-299-21	CONNECTOR (RECEPTACLE)(MIC CH3)	
12	*3-701-948-16	LABEL (T1.6A), FUSE		J908	1-562-299-21	CONNECTOR (RECEPTACLE)(MIC CH4)	
13	*3-345-457-01	(UK)...LABEL, MODEL NUMBER (UK)		J909	1-562-299-21	CONNECTOR (RECEPTACLE)(MIC CH4)	
	*3-345-458-01	(AEP)...LABEL, MODEL NUMBER (AE)		S935	1-553-539-00	SWITCH, MICRO	

7-2.

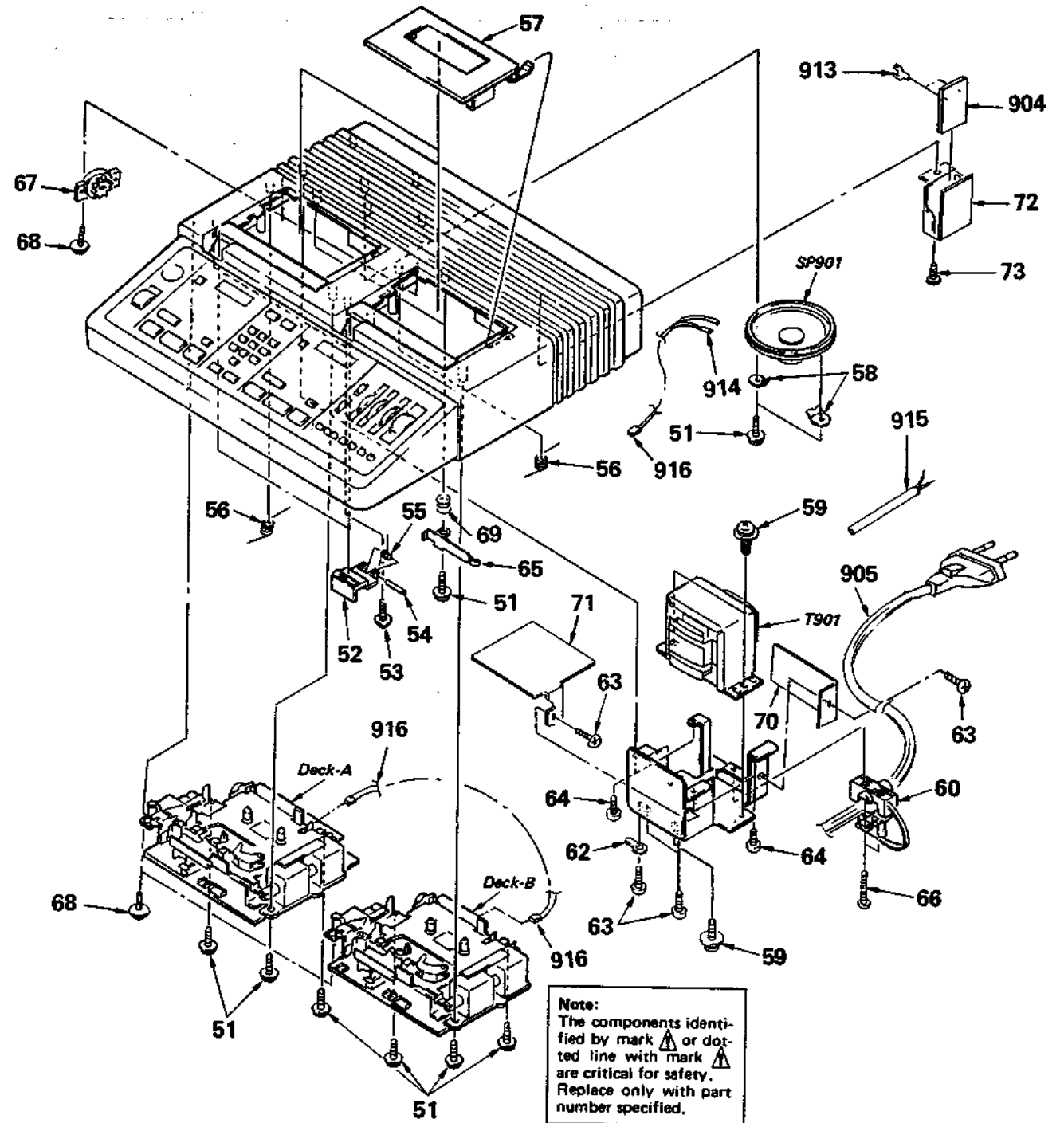

No.	Part No.	Description	Remarks	No.	Part No.	Description	Remarks
51	7-685-647-79	SCREW, TAPPING		67	3-319-224-31	DAMPER, SMALL	
52	3-345-420-11	BUTTON (EJECT)		68	7-685-647-79	SCREW (+ PTP DIA.12 WH 3)	
53	3-669-480-21	+ PTPWH 2		69	3-307-380-00	SPRING, COMPRESION	
54	3-703-358-04	PIN, PARALLEL (DIA. 2X22)		70	*3-345-460-01	PLATE (T2), SHIELD	
55	3-345-423-01	SPRING, TORSTION		71	*3-345-459-01	PLATE (T1), SHIELD	
56	3-345-422-01	SPRING, TORSTION		72	*3-335-231-01	COVER, POWER	
57	X-3315-030-1	HOLDER ASSY, CASSETTE		73	7-685-134-19	SCREW +BTP 2.6X8 TYPE2 N-S	
58	3-845-110-00	RETAINER, SPEAKER		904	*1-621-227-11	PC BOARD, POWER	
59	7-682-661-09	SCREW +PSW 4X8		905	Δ.1-558-245-11	(AEP)...CORD, POWER	
60	3-556-081-00	RETAINER (B), CORD		913	1-535-416-00	TERMINAL	
62	7-623-508-01	LUG, 3		914	1-535-047-00	FASTEN RECEPTACLE	
63	7-682-147-01	SCREW +BVTY 3X6 (S)		915	Δ.1-534-777-00	(UK)...CORD, POWER	
64	7-685-647-79	SCREW +BVTY 3X10 TYPE2 N-S		916	*1-562-147-11	HOUSING, CONNECTOR 2P	
65	3-345-417-01	SPRING (CASSETTE RETAINER)		T901	Δ.1-449-478-11	TRANSFORMER, POWER	
66	7-621-775-80	SCREW +B 2.6X16		SP901	1-503-344-21	SPEAKER	

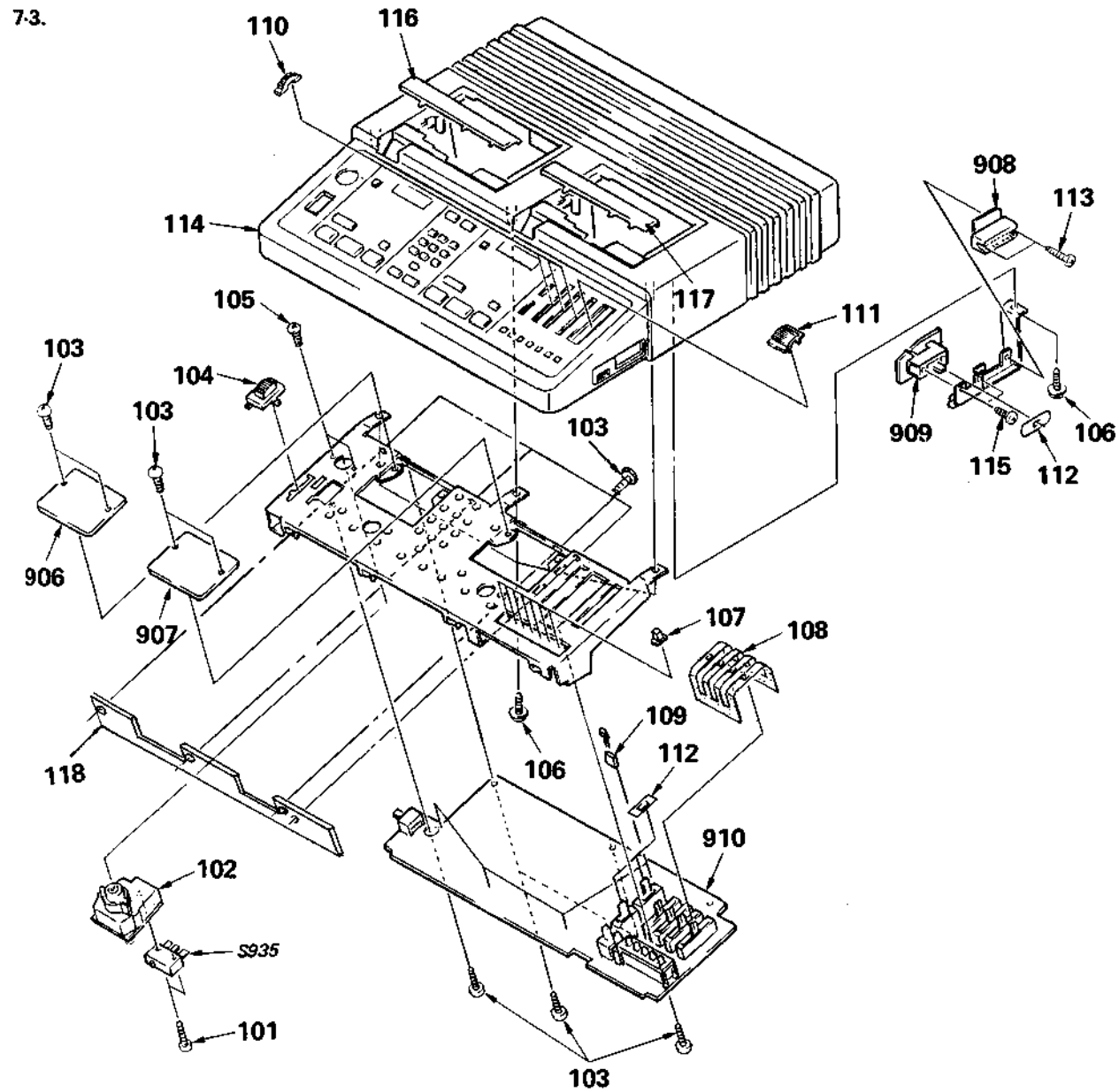

No.	Part No.	Description	Remarks	No.	Part No.	Description	Remarks
101	3-315-015-00	SCREW, TAPPING		113	7-621-770-XX	SCREW +P 2.6X8	
102	3-315-028-00	SWITCH, KEY		114	X-3315-029-1	CABINET (FRONT) ASSY	
103	7-682-147-01	SCREW +BVTI 3X6 (S)		115	7-628-254-00	SCREW +PS 2.6X5	
104	3-345-425-11	KNOB (SLIDE)		116	3-345-428-21	COVER (VERTICAL ADJUSTMENT)	
105	7-821-770-XX	SCREW +P 2.6 X 8		117	3-345-428-31	COVER (VERTICAL ADJUSTMENT)	
106	7-685-647-79	SCREW (+ PTP DIA.12 WH 3)		118	*3-345-451-01	REINFORCEMENT	
107	3-345-418-11	BUTTON		906	*1-625-466-11	PC BOARD, LED (A)	
108	*3-345-427-01	COVER (VOLUME)		907	*1-625-467-11	PC BOARD, LED (B)	
109	*3-345-439-01	HOLDER, LED		908	*1-625-463-11	PC BOARD, 12P CONNECTOR	
110	3-323-562-01	KNOB (B)		909	*1-625-464-11	PC BOARD, SWITCH	
111	3-323-561-01	KNOB (A)		910	*A-3089-330-A	MOUNTED PCB, SYSTEM CONTROL	
112	*3-315-010-00	COVER, SWITCH					

7-4. MECHANISM
DECK A: MB-246A-57
DECK B: MB-246B-57

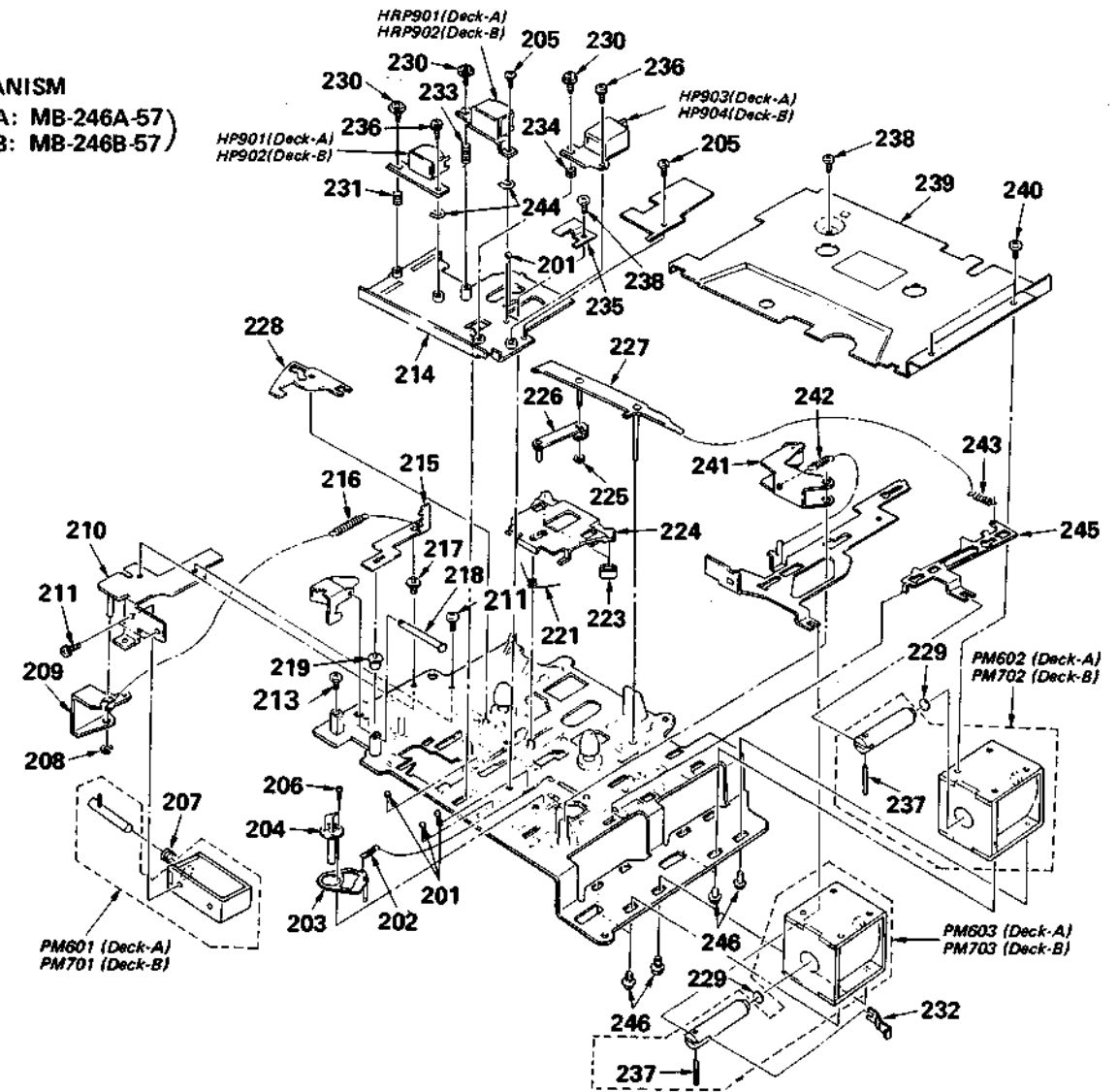

No.	Part No.	Description	Remarks	No.	Part No.	Description	Remarks
201	7-671-111-11	STEEL, BOUL 1.5MM		231	3-345-409-01	SPRING, COMPRESSION	
202	3-509-127-00	SPRING, TENSION		232	3-323-606-01	SPRING	
203	X-3323-501-1	LEVER ASSY, F.I		233	3-345-408-01	SPRING, COMPRESSION	
204	3-323-654-01	BEARING, CAPSTAN		234	3-345-407-01	SPRING, COMPRESSION	
				235	3-323-520-01	SPRING	
205	7-627-553-17	SCREW, PRECISION +P 2X2		236	7-628-253-00	SCREW +PS 2X4	
206	7-627-551-58	SCREW, PRECISION +P 1.4X3		237	7-626-320-21	PIN, SPRING 3X10	
207	3-315-098-01	SPRING, COMPRESSION		238	7-621-775-10	SCREW +B 2.6X4	
208	7-624-105-04	STOP RING 2.3, TYPE -E		239	*3-345-411-01	COVER, MD	
209	*3-315-097-01	PLATE, EJECT SELECT		240	7-682-546-09	SCREW +B 3X5	
210	*X-3315-017-1	BRACKET ASSY, SOLENOID		241	X-3323-503-1	PINCH LEVER ASSY	
211	7-628-253-90	SCREW +PS 2.6X4		242	3-527-189-00	SPRING, TENSION	
213	7-685-133-19	SCREW +BTP 2.6X6 TYPE 2 N-S		243	3-323-657-01	SPRING, TENSION	
214	*X-3315-018-1	CHASSIS ASSY, HEAD		244	3-578-138-01	SEAM t=0.1	
215	*3-315-092-01	PLATE, LOCK, CASSETTE HOLDER			3-578-138-11	SEAM t=0.2	
216	4-858-478-00	SPRING, TENSION		245	3-323-542-01	LEVER, FUNCTION, F/R	
217	*3-315-094-01	SHAFT (B), LOCK PLATE		246	7-682-647-09	SCREW +PSW 3X6	
218	3-323-551-01	SHAFT, FULCRUM, EJECT		HP901	1-543-497-12	(DECK-A)...HEAD, MAGNETIC (PLAYBACK)	
219	*3-315-093-01	SHAFT (A), LOCK PLATE		HP902	1-543-497-12	(DECK-B)...HEAD, MAGNETIC (PLAYBACK)	
221	3-323-508-01	SPRING		HP903	8-825-659-00	(DECK-A)...HEAD, MONITOR	
223	3-323-596-01	RUBBER, BRAKE		HP904	8-825-659-00	(DECK-B)...HEAD, MONITOR	
224	*3-323-511-01	LEVER, BRAKE		HRP901	1-543-498-11	(DECK-A)...HEAD, MAGNETIC (REC/PB)	
225	3-321-483-11	RING, RETAINING		HRP902	1-543-498-11	(DECK-B)...HEAD, MAGNETIC (REC/PB)	
226	X-3323-507-1	LEVER ASSY, F/R		PM601	1-454-179-21	(DECK-A)...SOLENOID, PLUNGER (EJECT)	
227	*X-3315-020-1	ARM ASSY, F/R		PM602	1-454-385-21	(DECK-A)...SOLENOID, PLUNGER (FF/REW)	
228	*3-323-518-01	PLATE, PREVENTION, EJECT		PM603	1-454-385-21	(DECK-A)...SOLENOID, PLUNGER (FWD)	
229	3-323-645-01	STOPPER		PM701	1-454-179-21	(DECK-B)...SOLENOID, PLUNGER (EJECT)	
230	3-701-468-00	SCREW (+- 2X4), LOCK		PM702	1-454-385-21	(DECK-B)...SOLENOID, PLUNGER (FF/REW)	
				PM703	1-454-385-21	(DECK-B)...SOLENOID, PLUNGER (FWD)	

7-5. MECHANISM
(DECK A: MB-246A-57)
(DECK B: MB-246B-57)

SECTION 8
ELECTRICAL PARTS LIST

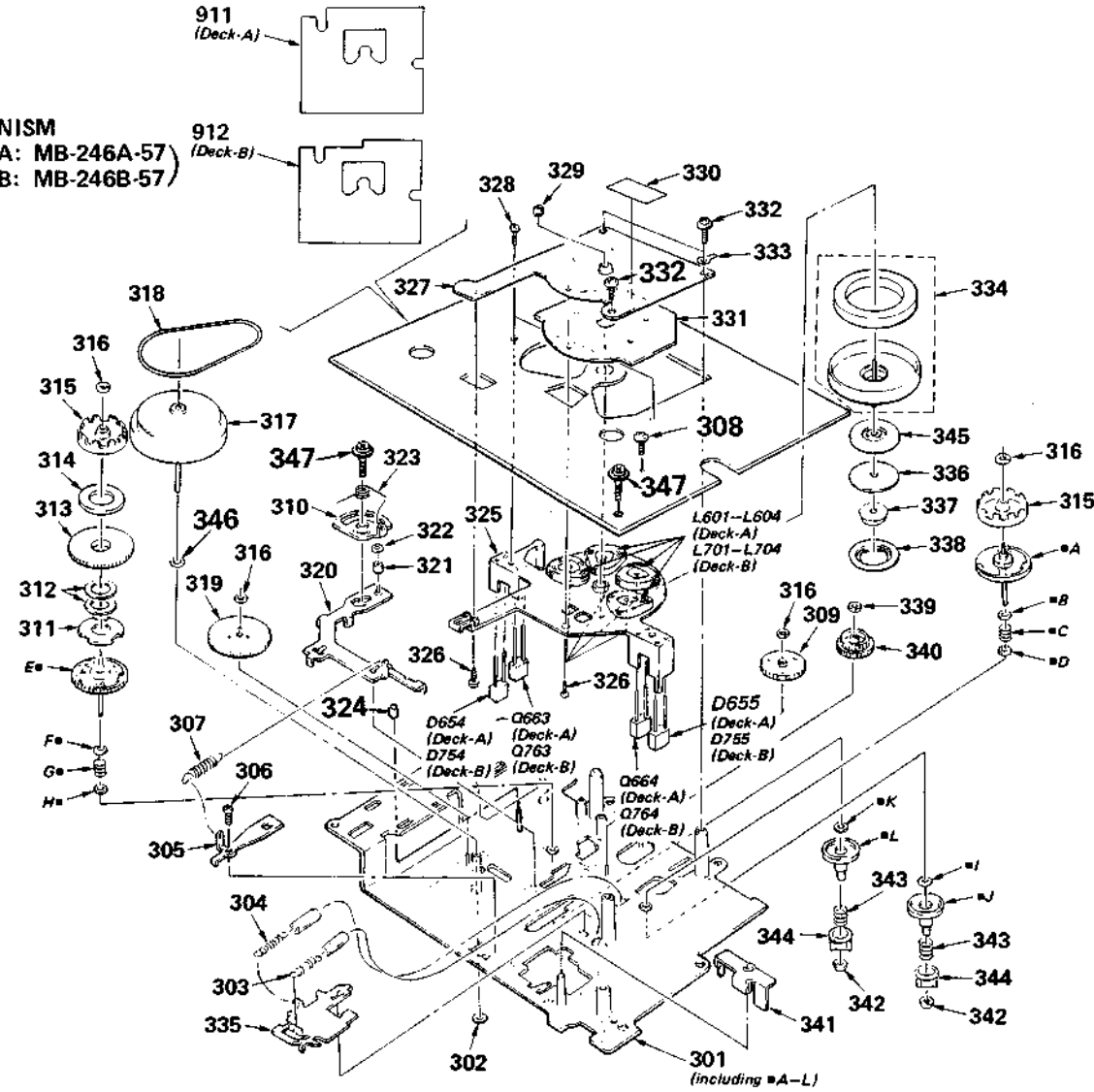

No.	Part No.	Description	Remarks	No.	Part No.	Description	Remarks
301	X-3316-028-1	CHASSIS ASSY, MECHANISM		328	7-685-104-19	SCREW +P 2X6 TYPE2 NON-SLIT	
302	3-325-698-01	RING, RETAINING		329	3-547-625-00	SCREW, THRUST ADJUST	
303	3-701-788-XX	SPRING, TENSION		330	3-846-312-00	SPACER	
304	3-305-903-00	SPRING, TENSION		331	3-323-601-01	SHEET, INSULATING, COIL	
305	X-3323-504-1	SPRING ASSY, LOCK		332	7-685-133-19	SCREW +BTP 2.6X6 TYPE2 N-S	
306	3-703-502-01	SCREW		333	7-623-507-01	LUG, 2.6	
307	4-858-478-00	SPRING, TENSION		334	X-3323-525-1	MAGNET ASSY, ROTOR	
308	7-621-775-10	SCREW +B 2.6X4		335	*3-323-506-01	CHASSIS (E), HEAD	
309	3-323-539-01	GEAR (B), F/R		336	3-323-656-01	WASHER	
310	X-3323-506-1	CAM ASSY, S		337	3-323-515-01	GEAR, M	
311	3-561-827-00	PLATE (A), HYSTERESIS		338	3-323-655-01	PLATE, CLUTCH	
312	3-307-493-01	SPACER (t=0.1)		339	3-321-483-11	RING, RETAINING	
	3-307-493-11	SPACER (t=0.15)		340	3-323-516-01	GEAR (A), F/R	
	3-307-493-21	SPACER (t=0.2)		341	*3-345-410-01	LEVER (A), EJECT	
313	3-307-953-00	MAGNET, REEL TABLE		342	3-307-362-00	CAP. REEL	
314	3-307-313-00	PLATE, YOKE		343	3-307-380-00	SPRING, COMPRESSION	
315	3-323-541-01	PLATE		344	3-307-363-00	CLAM (N), REEL	
316	3-307-948-01	WASHER, NYLON		345	3-310-071-21	TABLE (M), REEL	
317	X-3315-019-1	FLYWHEEL ASSY		346	3-701-437-01	WASHER (T=0.13)	
318	3-323-651-01	BELT		347	3-342-759-01	SCREW (B 1.7X6), TAPPING	
319	3-323-540-01	IDLER, FWD		911	*A-3089-335-A	MOUNTED PCB, SERVO (A)	
320	X-3323-510-1	LEVER ASSY, S		912	*A-3089-336-A	MOUNTED PCB, SERVO (B)	
321	3-323-534-01	ROLLER (S LEVER)		L601	1-462-196-21	(DECK-A)...COIL, MOTOR (STATOR)	
322	3-570-615-00	POLY-WASHER (DIA.1.2)		L602	1-462-196-21	(DECK-A)...COIL, MOTOR (STATOR)	
323	3-323-587-01	SPRING		L603	1-462-196-21	(DECK-A)...COIL, MOTOR (STATOR)	
324	3-319-662-01	RUBBER, BRAKE		L604	1-462-196-21	(DECK-A)...COIL, MOTOR (STATOR)	
325	*3-323-552-01	BRACKET, COIL		L701	1-462-196-21	(DECK-B)...COIL, MOTOR (STATOR)	
326	3-323-501-01	SCREW (M1.4X3)		L702	1-462-196-21	(DECK-B)...COIL, MOTOR (STATOR)	
327	*X-3323-502-1	CHASSIS ASSY, STATOR		L703	1-462-196-21	(DECK-B)...COIL, MOTOR (STATOR)	
				L704	1-462-196-21	(DECK-B)...COIL, MOTOR (STATOR)	

NOTE:

- Due to standardization, replacements in the parts list may be different from the parts specified in the diagrams or the components used on the set.
- Items marked "*" are not stocked since they are seldom required for routine service. Some delay should be anticipated when ordering these items.
- If there are two or more same circuits in a set such as a stereophonic machine, only typical circuit parts may be indicated and capacitors and resistors in other same circuits may be omitted.

CAPACITORS:
MF: μ F, PF: μ PF.

RESISTORS
• All resistors are in ohms.
• F: nonflammable

COILS
• MMH: mH, UH: μ H

SEMICONDUCTORS
In each case, U: μ , for example:
UA...: μ A..., UPA...: μ PA...,
UPC...: μ PC, UPD...: μ PD...

The components identified by mark Δ or dotted line with mark Δ are critical for safety. Replace only with part number specified.

Ref.No.	Part No.	Description	Ref.No.	Part No.	Description				
901	*A-3089-334-A	MOUNTED PCB, AUDIO	C166	1-162-290-31	CERAMIC	470PF	10%	50V	
902	*1-625-939-11	PC BOARD, MIC	C167	1-130-475-00	MYLAR	0.0022MF	5%	50V	
903	*1-533-189-11	HOLDER, FUSE	C168	1-123-611-00	ELECT	1MF	20%	50V	
904	*1-621-227-11	PC BOARD, POWER	C169	1-123-611-00	ELECT	1MF	20%	50V	
905	Δ 1-558-245-11	(AEP)...CORD, POWER	C201	1-123-611-00	ELECT	1MF	20%	50V	
906	*1-625-466-11	PC BOARD, LED (A)	C202	1-162-835-11	CERAMIC	0.0047MF	10%	16V	
907	*1-625-467-11	PC BOARD, LED (B)	C203	1-162-282-31	CERAMIC	100PF	10%	50V	
908	*1-625-463-11	PC BOARD, 12P CONNECTOR	C204	1-124-927-11	ELECT	4.7MF	20%	50V	
909	*1-625-464-11	PC BOARD, SWITCH	C205	1-162-286-31	CERAMIC	220PF	10%	50V	
910	*A-3089-330-A	MOUNTED PCB, SYSTEM CONTROL	C206	1-123-611-00	ELECT	1MF	20%	50V	
911	*A-3089-335-A	MOUNTED PCB, SERVO (A)	C212	1-162-294-31	CERAMIC	0.001MF	10%	50V	
912	*A-3089-336-A	MOUNTED PCB, SERVO (B)	C213	1-124-444-00	ELECT	220MF	20%	6.3V	
913	1-535-416-00	TERMINAL	C214	1-124-927-11	ELECT	4.7MF	20%	50V	
914	1-535-047-00	FASTEN RECEPTACLE	C215	1-162-284-31	CERAMIC	150PF	10%	50V	
915	Δ 1-534-777-00	(UK)...CORD, POWER	C216	1-123-611-00	ELECT	1MF	20%	50V	
916	*1-562-147-11	HOUSING, CONNECTOR 2P	C217	1-161-379-00	CERAMIC	0.01MF	20%	16V	
C101	1-123-611-00	ELECT	1MF	20%	50V				
C102	1-162-835-11	CERAMIC	0.0047MF	10%	16V				
C103	1-162-282-31	CERAMIC	100PF	10%	50V				
C104	1-124-927-11	ELECT	4.7MF	20%	50V				
C105	1-162-286-31	CERAMIC	220PF	10%	50V				
C106	1-123-611-00	ELECT	1MF	20%	50V				
C112	1-162-294-31	CERAMIC	0.001MF	10%	50V				
C113	1-124-444-00	ELECT	220MF	20%	6.3V				
C114	1-124-927-11	ELECT	4.7MF	20%	50V				
C115	1-162-284-31	CERAMIC	150PF	10%	50V				
C116	1-123-611-00	ELECT	1MF	20%	50V				
C117	1-161-379-00	CERAMIC	0.01MF	20%	16V				
C118	1-130-475-00	MYLAR	0.0022MF	5%	50V				
C119	1-123-611-00	ELECT	1MF	20%	50V				
C120	1-123-875-11	ELECT	10MF	20%	50V				
C121	1-161-379-00	CERAMIC	0.01MF	20%	16V				
C122	1-162-282-31	CERAMIC	100PF	10%	50V				
C123	1-162-284-31	CERAMIC	150PF	10%	50V				
C151	1-106-347-00	MYLAR	0.0015MF	5%	200V				
C152	1-130-483-00	MYLAR	0.01MF	5%	50V				
C153	1-123-611-00	ELECT	1MF	20%	50V				
C155	1-161-327-00	CERAMIC	0.0033MF	20%	16V				
C156	1-162-294-31	CERAMIC	0.001MF	10%	50V				
C157	1-162-286-31	CERAMIC	220PF	10%	50V				
C158	1-123-875-11	ELECT	10MF	20%	50V				
C159	1-162-286-31	CERAMIC	220PF	10%	50V				
C160	1-123-611-00	ELECT	1MF	20%	50V				
C161	1-123-611-00	ELECT	1MF	20%	50V				
C162	1-126-154-11	ELECT	4.7MF	20%	6.3V				
C164	1-161-379-00	CERAMIC	0.01MF	20%	16V				
C165	1-162-282-31	CERAMIC	100PF	10%	50V				
C252	1-130-483-00	MYLAR	0.01MF	5%	50V				
C253	1-123-611-00	ELECT	1MF	20%	50V				
C255	1-161-327-00	CERAMIC	0.0033MF	20%	16V				
C256	1-162-294-31	CERAMIC	0.001MF	10%	50V				
C257	1-162-286-31	CERAMIC	220PF	10%	50V				
C258	1-123-875-11	ELECT	10MF	20%	50V				
C259	1-162-286-31	CERAMIC	220PF	10%	50V				
C260	1-123-611-00	ELECT	1MF	20%	50V				
C261	1-123-611-00	ELECT	1MF	20%	50V				
C262	1-126-154-11	ELECT	4.7MF	20%	6.3V				
C264	1-161-379-00	CERAMIC	0.01MF	20%	16V				
C265	1-162-282-31	CERAMIC	100PF	10%	50V				
C266	1-162-290-31	CERAMIC	470PF	10%	50V				
C267	1-130-475-00	MYLAR	0.0022MF	5%	50V				
C268	1-123-611-00	ELECT	1MF	20%	50V				
C269	1-123-611-00	ELECT	1MF	20%	50V				
C301	1-123-611-00	ELECT	1MF	20%	50V				
C302	1-162-835-11	CERAMIC	0.0047MF	10%	16V				
C303	1-162-282-31	CERAMIC	100PF	10%	50V				
C304	1-124-927-11	ELECT	4.7MF	20%	50V				
C305	1-162-286-31	CERAMIC	220PF	10%	50V				
C306	1-123-611-00	ELECT	1MF	20%	50V				
C312	1-162-294-31	CERAMIC	0.001MF	10%	50V				
C313	1-124-444-00	ELECT	220MF	20%	6.3V				

Ref.No.	Part No.	Description				Ref.No.	Part No.	Description			
C314	1-124-927-11	ELECT	4.7MF	20%	50V	C404	1-124-927-11	ELECT	4.7MF	20%	50V
C315	1-162-284-31	CERAMIC	150PF	10%	50V	C405	1-162-286-31	CERAMIC	220PF	10%	50V
C316	1-123-611-00	ELECT	1MF	20%	50V	C406	1-123-611-00	ELECT	1MF	20%	50V
C317	1-161-379-00	CERAMIC	0.01MF	20%	16V	C412	1-162-294-31	CERAMIC	0.001MF	10%	50V
C318	1-130-475-00	MYLAR	0.0022MF	5%	50V	C413	1-124-444-00	ELECT	220MF	20%	6.3V
C319	1-123-611-00	ELECT	1MF	20%	50V	C414	1-124-927-11	ELECT	4.7MF	20%	50V
C320	1-123-875-11	ELECT	10MF	20%	50V	C415	1-162-284-31	CERAMIC	150PF	10%	50V
C321	1-161-379-00	CERAMIC	0.01MF	20%	16V	C416	1-123-611-00	ELECT	1MF	20%	50V
C322	1-162-282-31	CERAMIC	100PF	10%	50V	C417	1-161-379-00	CERAMIC	0.01MF	20%	16V
C323	1-162-284-31	CERAMIC	150PF	10%	50V	C418	1-130-475-00	MYLAR	0.0022MF	5%	50V
C351	1-124-120-11	ELECT	220MF	20%	16V	C419	1-123-611-00	ELECT	1MF	20%	50V
C352	1-124-120-11	ELECT	220MF	20%	16V	C420	1-123-875-11	ELECT	10MF	20%	50V
C353	1-124-120-11	ELECT	220MF	20%	16V	C421	1-161-379-00	CERAMIC	0.01MF	20%	16V
C354	1-124-120-11	ELECT	220MF	20%	16V	C422	1-162-282-31	CERAMIC	100PF	10%	50V
C355	1-161-379-00	CERAMIC	0.01MF	20%	16V	C423	1-162-284-31	CERAMIC	150PF	10%	50V
C356	1-161-379-00	CERAMIC	0.01MF	20%	16V	C451	1-124-563-11	ELECT	2200MF	20%	25V
C357	1-161-379-00	CERAMIC	0.01MF	20%	16V	C452	1-124-563-11	ELECT	2200MF	20%	25V
C358	1-161-379-00	CERAMIC	0.01MF	20%	16V	C453	1-124-563-11	ELECT	2200MF	20%	25V
C359	1-124-902-00	ELECT	0.47MF	20%	50V	C454	1-130-491-00	MYLAR	0.047MF	5%	50V
C360	1-162-290-31	CERAMIC	470PF	10%	50V	C455	1-130-491-00	MYLAR	0.047MF	5%	50V
C361	1-130-481-00	MYLAR	0.0068MF	5%	50V	C456	1-124-120-11	ELECT	220MF	20%	16V
C362	1-124-902-00	ELECT	0.47MF	20%	50V	C458	1-130-491-00	MYLAR	0.047MF	5%	50V
C363	1-124-902-00	ELECT	0.47MF	20%	50V	C459	1-124-472-11	ELECT	470MF	20%	6.3V
C364	1-162-282-31	CERAMIC	100PF	10%	50V	C461	1-124-472-11	ELECT	470MF	20%	6.3V
C365	1-124-902-00	ELECT	0.47MF	20%	50V	C462	1-125-447-11	DOUBLE LAYERS	1F		5.5V
C366	1-123-611-00	ELECT	1MF	20%	50V	C463	1-130-491-00	MYLAR	0.047MF	5%	50V
C367	1-162-294-31	CERAMIC	0.001MF	10%	50V	C464	1-130-491-00	MYLAR	0.047MF	5%	50V
C368	1-123-611-00	ELECT	1MF	20%	50V	C465	1-124-120-11	ELECT	220MF	20%	16V
C369	1-162-292-31	CERAMIC	680PF	10%	50V	C466	1-161-039-00	CERAMIC	0.001MF	10%	50V
C370	1-123-875-11	ELECT	10MF	20%	50V	C467	1-161-039-00	CERAMIC	0.001MF	10%	50V
C371	1-124-120-11	ELECT	220MF	20%	16V	C468	1-161-039-00	CERAMIC	0.001MF	10%	50V
C372	1-124-120-11	ELECT	220MF	20%	16V	C469	1-124-963-11	ELECT	33MF	20%	16V
C373	1-130-499-00	MYLAR	0.22MF	5%	50V	C470	1-161-051-00	CERAMIC	0.01MF	10%	50V
C374	1-124-927-11	ELECT	4.7MF	20%	50V	C471	1-161-051-00	CERAMIC	0.01MF	10%	50V
C375	1-124-477-11	ELECT	47MF	20%	16V	C472	1-124-224-00	ELECT	47MF	20%	6.3V
C376	1-123-875-11	ELECT	10MF	20%	50V	C501	1-123-611-00	ELECT	1MF	20%	50V
C377	1-123-611-00	ELECT	1MF	20%	50V	C502	1-162-835-11	CERAMIC	0.0047MF	10%	16V
C378	1-123-611-00	ELECT	1MF	20%	50V	C503	1-162-282-31	CERAMIC	100PF	10%	50V
C379	1-123-611-00	ELECT	1MF	20%	50V	C504	1-124-927-11	ELECT	4.7MF	20%	50V
C380	1-123-611-00	ELECT	1MF	20%	50V	C505	1-162-286-31	CERAMIC	220PF	10%	50V
C381	1-130-475-00	MYLAR	0.0022MF	5%	50V	C506	1-123-611-00	ELECT	1MF	20%	50V
C382	1-123-611-00	ELECT	1MF	20%	50V	C512	1-162-294-31	CERAMIC	0.001MF	10%	50V
C383	1-124-902-00	ELECT	0.47MF	20%	50V	C513	1-124-444-00	ELECT	220MF	20%	6.3V
C384	1-161-379-00	CERAMIC	0.01MF	20%	16V	C514	1-124-927-11	ELECT	4.7MF	20%	50V
C385	1-161-379-00	CERAMIC	0.01MF	20%	16V	C515	1-162-284-31	CERAMIC	150PF	10%	50V
C386	1-161-379-00	CERAMIC	0.01MF	20%	16V	C516	1-123-611-00	ELECT	1MF	20%	50V
C387	1-161-379-00	CERAMIC	0.01MF	20%	16V	C517	1-161-379-00	CERAMIC	0.01MF	20%	16V
C388	1-161-051-00	CERAMIC	0.01MF	10%	50V	C518	1-130-475-00	MYLAR	0.0022MF	5%	50V
C389	1-161-051-00	CERAMIC	0.01MF	10%	50V	C519	1-123-611-00	ELECT	1MF	20%	50V
C390	1-162-851-11	CERAMIC	0.1MF	10%	16V	C520	1-123-875-11	ELECT	10MF	20%	50V
C391	1-161-379-00	CERAMIC	0.01MF	20%	16V	C521	1-161-379-00	CERAMIC	0.01MF	20%	16V
C392	1-161-379-00	CERAMIC	0.01MF	20%	16V	C601	1-123-611-00	ELECT	1MF	20%	50V
C393	1-162-282-31	CERAMIC	100PF	10%	50V	C602	1-162-835-11	CERAMIC	0.0047MF	10%	16V
C394	1-161-379-00	CERAMIC	0.01MF	20%	16V	C603	1-162-282-31	CERAMIC	100PF	10%	50V
C395	1-123-611-00	ELECT	1MF	20%	50V	C604	1-124-927-11	ELECT	4.7MF	20%	50V
C401	1-123-611-00	ELECT	1MF	20%	50V	C605	1-162-286-31	CERAMIC	220PF	10%	50V
C402	1-162-835-11	CERAMIC	0.0047MF	10%	16V	C606	1-123-611-00	ELECT	1MF	20%	50V
C403	1-162-282-31	CERAMIC	100PF	10%	50V						

Ref.No.	Part No.	Description			
C612	1-162-294-31	CERAMIC	0.001MF	10%	50V
C613	1-124-444-00	ELECT	220MF	20%	6.3V
C614	1-124-927-11	ELECT	4.7MF	20%	50V
C615	1-162-284-31	CERAMIC	150PF	10%	50V
C616	1-123-611-00	ELECT	1MF	20%	50V
C617	1-161-379-00	CERAMIC	0.01MF	20%	16V
C618	1-130-475-00	MYLAR	0.0022MF	5%	50V
C619	1-123-611-00	ELECT	1MF	20%	50V
C620	1-123-875-11	ELECT	10MF	20%	50V
C621	1-161-379-00	CERAMIC	0.01MF	20%	16V
C651	1-162-294-31	CERAMIC	0.001MF	10%	50V
C652	1-162-294-31	CERAMIC	0.001MF	10%	50V
C653	1-124-245-00	ELECT	4.7MF	20%	25V
C654	1-124-462-00	ELECT	10MF	20%	16V
C655	1-124-236-00	ELECT	47MF	20%	10V
C656	1-124-463-00	ELECT	0.1MF	20%	50V
C657	1-124-257-00	ELECT	2.2MF	20%	50V
C658	1-130-487-00	MYLAR	0.022MF	5%	50V
C659	1-130-497-00	MYLAR	0.15MF	5%	50V
C660	1-136-177-00	FILM	1MF	5%	50V
C661	1-136-177-00	FILM	1MF	5%	50V
C662	1-124-245-00	ELECT	4.7MF	20%	25V
C663	1-162-282-31	CERAMIC	100PF	10%	50V
C664	1-162-282-31	CERAMIC	100PF	10%	50V
C665	1-124-908-11	ELECT	2.2MF	20%	25V
C666	1-124-257-00	ELECT	2.2MF	20%	50V
C667	1-124-257-00	ELECT	2.2MF	20%	50V
C668	1-124-257-00	ELECT	2.2MF	20%	50V
C669	1-126-101-11	ELECT	100MF	20%	16V
C670	1-126-101-11	ELECT	100MF	20%	16V
C701	1-123-611-00	ELECT	1MF	20%	50V
C702	1-162-835-11	CERAMIC	0.0047MF	10%	16V
C703	1-162-282-31	CERAMIC	100PF	10%	50V
C704	1-124-927-11	ELECT	4.7MF	20%	50V
C705	1-162-286-31	CERAMIC	220PF	10%	50V
C706	1-123-611-00	ELECT	1MF	20%	50V
C712	1-162-294-31	CERAMIC	0.001MF	10%	50V
C713	1-124-444-00	ELECT	220MF	20%	6.3V
C714	1-124-927-11	ELECT	4.7MF	20%	50V
C715	1-162-284-31	CERAMIC	150PF	10%	50V
C716	1-123-611-00	ELECT	1MF	20%	50V
C717	1-161-379-00	CERAMIC	0.01MF	20%	16V
C718	1-130-475-00	MYLAR	0.0022MF	5%	50V
C719	1-123-611-00	ELECT	1MF	20%	50V
C720	1-123-875-11	ELECT	10MF	20%	50V
C721	1-161-379-00	CERAMIC	0.01MF	20%	16V
C751	1-162-294-31	CERAMIC	0.001MF	10%	50V
C752	1-162-294-31	CERAMIC	0.001MF	10%	50V
C753	1-124-245-00	ELECT	4.7MF	20%	25V
C754	1-124-462-00	ELECT	10MF	20%	16V
C755	1-124-236-00	ELECT	47MF	20%	10V
C756	1-124-463-00	ELECT	0.1MF	20%	50V
C757	1-124-257-00	ELECT	2.2MF	20%	50V
C758	1-130-487-00	MYLAR	0.022MF	5%	50V
C759	1-130-497-00	MYLAR	0.15MF	5%	50V
C760	1-136-177-00	FILM	1MF	5%	50V
C761	1-136-177-00	FILM	1MF	5%	50V

Ref.No.	Part No.	Description			
C762	1-124-245-00	ELECT	4.7MF	20%	25V
C763	1-162-282-31	CERAMIC	100PF	10%	50V
C764	1-162-282-31	CERAMIC	100PF	10%	50V
C765	1-124-908-11	ELECT	22MF	20%	25V
C766	1-123-611-00	ELECT	1MF	20%	50V
C767	1-124-257-00	ELECT	2.2MF	20%	50V
C768	1-124-257-00	ELECT	2.2MF	20%	50V
C769	1-126-101-11	ELECT	100MF	20%	16V
C770	1-126-101-11	ELECT	100MF	20%	16V
C801	1-123-611-00	ELECT	1MF	20%	50V
C802	1-162-835-11	CERAMIC	0.0047MF	10%	16V
C803	1-162-282-31	CERAMIC	100PF	10%	50V
C804	1-124-927-11	ELECT	4.7MF	20%	50V
C805	1-162-286-31	CERAMIC	220PF	10%	50V
C806	1-123-611-00	ELECT	1MF	20%	50V
C812	1-162-294-31	CERAMIC	0.001MF	10%	50V
C813	1-124-444-00	ELECT	220MF	20%	6.3V
C814	1-124-927-11	ELECT	4.7MF	20%	50V
C815	1-162-284-31	CERAMIC	150PF	10%	50V
C816	1-123-611-00	ELECT	1MF	20%	50V
C817	1-161-379-00	CERAMIC	0.01MF	20%	16V
C818	1-130-475-00	MYLAR	0.0022MF	5%	50V
C819	1-123-611-00	ELECT	1MF	20%	50V
C820	1-123-875-11	ELECT	10MF	20%	50V
C821	1-161-379-00	CERAMIC	0.01MF	20%	16V
C902	1-123-661-00	ELECT	100MF	20%	6.3V
C903	1-123-661-00	ELECT	100MF	20%	6.3V
C904	1-162-851-11	CERAMIC	0.1MF	10%	16V
C905	1-162-211-31	CERAMIC	33PF	5%	50V
C906	1-162-211-31	CERAMIC	33PF	5%	50V
C907	1-161-379-00	CERAMIC	0.01MF	20%	16V
C908	1-162-282-31	CERAMIC	100PF	10%	50V
C909	1-161-023-00	CERAMIC	0.068MF	10%	16V
C910	1-161-051-00	CERAMIC	0.01MF	10%	50V
C911	1-161-051-00	CERAMIC	0.01MF	10%	50V
C912	1-161-051-00	CERAMIC	0.01MF	10%	50V
C914	1-162-851-11	CERAMIC	0.1MF	10%	16V
C917	1-161-051-00	CERAMIC	0.01MF	10%	25V
CNJ101*1	-562-148-11	HOUSING, CONNECTOR	3P		
CNJ102*1	-562-148-11	HOUSING, CONNECTOR	3P		
CNJ103*1	-562-148-11	HOUSING, CONNECTOR	3P		
CNJ104*1	-562-148-11	HOUSING, CONNECTOR	3P		
CNJ105*1	-562-148-11	HOUSING, CONNECTOR	3P		
CNJ106*1	-562-148-11	HOUSING, CONNECTOR	3P		
CNJ107*1	-562-148-11	HOUSING, CONNECTOR	3P		
CNJ108*1	-562-148-11	HOUSING, CONNECTOR	3P		
CNJ109*1	-562-147-11	HOUSING, CONNECTOR	2P		
CNJ110*1	-562-147-11	HOUSING, CONNECTOR	2P		
CNJ111*1	-562-147-11	HOUSING, CONNECTOR	2P		
CNJ112*1	-562-147-11	HOUSING, CONNECTOR	2P		
CNJ113*1	-562-151-11	HOUSING, CONNECTOR	6P		
CNJ117*1	-562-149-11	HOUSING, CONNECTOR	4P		
CNJ118*1	-562-148-11	HOUSING, CONNECTOR	3P		
CNJ120*1	-562-149-11	HOUSING, CONNECTOR	4P		
CNJ124*1	-562-148-11	HOUSING, CONNECTOR	3P		
CNJ128*1	-562-150-11	HOUSING, CONNECTOR	5P		

Ref.No.	Part No.	Description
CNJ903*	1-562-148-11	HOUSING, CONNECTOR 3P
CNJ909*	1-562-151-11	HOUSING, CONNECTOR 6P
CNJ912*	1-562-148-11	HOUSING, CONNECTOR 3P
CNJ913*	1-562-153-11	HOUSING, CONNECTOR 8P
CNJ914*	1-562-150-11	HOUSING, CONNECTOR 5P
CNJ915*	1-562-152-11	HOUSING, CONNECTOR 7P
CNJ916*	1-562-153-11	HOUSING, CONNECTOR 8P
CNJ918*	1-562-153-11	HOUSING, CONNECTOR 8P
CNJ919*	1-562-153-11	HOUSING, CONNECTOR 8P
CNJ920*	1-562-150-11	HOUSING, CONNECTOR 5P
CNJ921*	1-562-152-11	HOUSING, CONNECTOR 7P
CNJ922*	1-562-153-11	HOUSING, CONNECTOR 8P
CNJ923*	1-562-149-11	HOUSING, CONNECTOR 4P
CNJ924*	1-562-149-11	HOUSING, CONNECTOR 4P
CNP101*	1-564-002-00	PIN, CONNECTOR 3P
CNP102*	1-564-002-00	PIN, CONNECTOR 3P
CNP103*	1-564-002-00	PIN, CONNECTOR 3P
CNP104*	1-564-002-00	PIN, CONNECTOR 3P
CNP105*	1-564-002-00	PIN, CONNECTOR 3P
CNP106*	1-564-002-00	PIN, CONNECTOR 3P
CNP107*	1-564-002-00	PIN, CONNECTOR 3P
CNP108*	1-564-002-00	PIN, CONNECTOR 3P
CNP109*	1-564-001-11	PIN, CONNECTOR 2P
CNP110*	1-564-001-11	PIN, CONNECTOR 2P
CNP111*	1-564-001-11	PIN, CONNECTOR 2P
CNP112*	1-564-001-11	PIN, CONNECTOR 2P
CNP113*	1-564-005-00	PIN, CONNECTOR 6P
CNP114*	1-564-003-00	PIN, CONNECTOR 4P
CNP115*	1-564-003-00	PIN, CONNECTOR 4P
CNP116*	1-564-003-00	PIN, CONNECTOR 4P
CNP117*	1-564-003-00	PIN, CONNECTOR 4P
CNP118*	1-564-002-00	PIN, CONNECTOR 3P
CNP119*	1-564-002-00	PIN, CONNECTOR 3P
CNP120*	1-564-003-00	PIN, CONNECTOR 4P
CNP122*	1-564-001-11	PIN, CONNECTOR 2P
CNP123*	1-508-742-00	PIN, CONNECTOR 3P
CNP124*	1-564-002-00	PIN, CONNECTOR 3P
CNP125*	1-564-002-00	PIN, CONNECTOR 3P
CNP126*	1-564-003-00	PIN, CONNECTOR 4P
CNP127*	1-564-006-11	PIN, CONNECTOR 7P
CNP128*	1-564-004-00	PIN, CONNECTOR 5P
CNP601*	1-564-001-11	PIN, CONNECTOR 2P
CNP602*	1-564-001-11	PIN, CONNECTOR 2P
CNP603*	1-564-001-11	PIN, CONNECTOR 2P
CNP604*	1-564-017-00	PIN, CONNECTOR 7P
CNP605*	1-564-014-00	PIN, CONNECTOR 4P
CNP606*	1-564-013-00	PIN, CONNECTOR 3P
CNP607*	1-564-001-11	PIN, CONNECTOR 2P
CNP701*	1-564-001-11	PIN, CONNECTOR 2P
CNP702*	1-564-001-11	PIN, CONNECTOR 2P
CNP703*	1-564-001-11	PIN, CONNECTOR 2P
CNP704*	1-564-017-00	PIN, CONNECTOR 7P
CNP705*	1-564-014-00	PIN, CONNECTOR 4P
CNP706*	1-564-014-00	PIN, CONNECTOR 4P
CNP707*	1-564-013-00	PIN, CONNECTOR 3P
CNP708*	1-564-001-11	PIN, CONNECTOR 2P
CNP901*	1-564-018-11	PIN, CONNECTOR 8P
CNP902*	1-564-013-00	PIN, CONNECTOR 3P
CNP903*	1-564-013-00	PIN, CONNECTOR 3P

Ref.No.	Part No.	Description
CNP904*	1-564-002-00	PIN, CONNECTOR 3P
CNP905*	1-564-006-11	PIN, CONNECTOR 7P
CNP906*	1-564-003-00	PIN, CONNECTOR 4P
CNP907*	1-564-006-11	PIN, CONNECTOR 7P
CNP908*	1-564-002-00	PIN, CONNECTOR 3P
CNP909*	1-564-016-00	PIN, CONNECTOR 6P
CNP910*	1-564-002-00	PIN, CONNECTOR 3P
CNP911*	1-564-017-00	PIN, CONNECTOR 7P
CNP912*	1-564-013-00	PIN, CONNECTOR 3P
CNP913*	1-564-007-00	PIN, CONNECTOR 8P
CNP914*	1-564-004-00	PIN, CONNECTOR 5P
CNP915*	1-564-006-11	PIN, CONNECTOR 7P
CNP916*	1-564-007-00	PIN, CONNECTOR 8P
CNP917*	1-564-017-00	PIN, CONNECTOR 7P
CNP918*	1-564-018-11	PIN, CONNECTOR 8P
CNP919*	1-564-018-11	PIN, CONNECTOR 8P
CNP920*	1-564-015-00	PIN, CONNECTOR 5P
CNP921*	1-564-017-00	PIN, CONNECTOR 7P
CNP922*	1-564-018-11	PIN, CONNECTOR 8P
CNP923*	1-564-014-00	PIN, CONNECTOR 4P
CNP924*	1-564-014-00	PIN, CONNECTOR 4P
CNP925*	1-564-001-11	PIN, CONNECTOR 2P
CNP926*	1-564-004-00	PIN, CONNECTOR 5P
D101	8-719-911-19	DIODE 1SS119
D102	8-719-911-19	DIODE 1SS119
D103	8-719-911-19	DIODE 1SS119
D104	8-719-911-19	DIODE 1SS119
D105	8-719-911-19	DIODE 1SS119
D151	8-719-911-19	DIODE 1SS119
D152	8-719-200-02	DIODE 10E2
D153	8-719-911-19	DIODE 1SS119
D154	8-719-911-19	DIODE 1SS119
D201	8-719-911-19	DIODE 1SS119
D202	8-719-911-19	DIODE 1SS119
D203	8-719-911-19	DIODE 1SS119
D204	8-719-911-19	DIODE 1SS119
D205	8-719-911-19	DIODE 1SS119
D251	8-719-911-19	DIODE 1SS119
D252	8-719-200-02	DIODE 10E2
D253	8-719-911-19	DIODE 1SS119
D254	8-719-911-19	DIODE 1SS119
D301	8-719-911-19	DIODE 1SS119
D302	8-719-911-19	DIODE 1SS119
D303	8-719-911-19	DIODE 1SS119
D304	8-719-911-19	DIODE 1SS119
D305	8-719-911-19	DIODE 1SS119
D351	8-719-911-19	DIODE 1SS119
D352	8-719-911-19	DIODE 1SS119
D353	8-719-911-19	DIODE 1SS119
D401	8-719-911-19	DIODE 1SS119
D402	8-719-911-19	DIODE 1SS119
D403	8-719-911-19	DIODE 1SS119
D404	8-719-911-19	DIODE 1SS119
D405	8-719-911-19	DIODE 1SS119
D451	8-719-200-02	DIODE 10E2
D452	8-719-200-02	DIODE 10E2
D453	8-719-200-02	DIODE 10E2
D454	8-719-200-92	DIODE 10E2
D455	8-719-200-02	DIODE 10E2

Ref.No.	Part No.	Description
D456	8-719-200-02	DIODE 10E2
D458	8-719-911-19	DIODE 1SS119
D459	8-719-911-19	DIODE 1SS119
D460	8-719-911-19	DIODE 1SS119
D461	8-719-911-19	DIODE 1SS119
D501	8-719-911-19	DIODE 1SS119
D502	8-719-911-19	DIODE 1SS119
D503	8-719-911-19	DIODE 1SS119
D504	8-719-911-19	DIODE 1SS119
D505	8-719-911-19	DIODE 1SS119
D601	8-719-911-19	DIODE 1SS119
D602	8-719-911-19	DIODE 1SS119
D603	8-719-911-19	DIODE 1SS119
D604	8-719-911-19	DIODE 1SS119
D605	8-719-911-19	DIODE 1SS119
D651	8-719-911-19	DIODE 1SS119
D654	8-719-103-15	DIODE SE304-2K
D655	8-719-103-15	DIODE SE304-2K
D656	8-719-911-19	DIODE 1SS119
D658	8-719-911-19	DIODE 1SS119
D659	8-719-200-02	DIODE 10E2
D660	8-719-110-11	DIODE RD9.1ES-B
D661	8-719-200-02	DIODE 10E2
D662	8-719-200-02	DIODE 10E2
D663	8-719-200-02	DIODE 10E2
D664	8-719-911-19	DIODE 1SS119
D665	8-719-200-02	DIODE 10E2
D666	8-719-911-19	DIODE 1SS119
D701	8-719-911-19	DIODE 1SS119
D702	8-719-911-19	DIODE 1SS119
D703	8-719-911-19	DIODE 1SS119
D704	8-719-911-19	DIODE 1SS119
D705	8-719-911-19	DIODE 1SS119
D751	8-719-911-19	DIODE 1SS119
D752	8-719-911-19	DIODE 1SS119
D753	8-719-911-19	DIODE 1SS119
D754	8-719-103-15	DIODE SE304-2K
D755	8-719-103-15	DIODE SE304-2K
D756	8-719-911-19	DIODE 1SS119
D757	8-719-911-19	DIODE 1SS119
D758	8-719-911-19	DIODE 1SS119
D759	8-719-200-02	DIODE 10E2
D760	8-719-110-11	DIODE RD9.1ES-B
D761	8-719-200-02	DIODE 10E2
D762	8-719-200-02	DIODE 10E2
D763	8-719-200-02	DIODE 10E2
D801	8-719-911-19	DIODE 1SS119
D802	8-719-911-19	DIODE 1SS119
D803	8-719-911-19	DIODE 1SS119
D804	8-719-911-19	DIODE 1SS119
D805	8-719-911-19	DIODE 1SS119
D901	8-719-936-56	DIODE DAN209S
D902	8-719-936-56	DIODE DAN209S
D903	8-719-936-56	DIODE DAN209S
D904	8-719-936-56	DIODE DAN209S
D905	8-719-936-56	DIODE DAN209S
D906	8-719-933-28	DIODE DAP209S
D907	8-719-933-28	DIODE DAP209S
D908	8-719-933-28	DIODE DAP209S

Ref.No.	Part No.	Description
D909	8-719-933-28	DIODE DAP209S
D910	8-719-936-56	DIODE DAN209S
D911	8-719-936-56	DIODE DAN209S
D912	8-719-800-33	DIODE SLP162B
D913	8-719-933-28	DIODE DAP209S
D914	8-719-933-28	DIODE DAP209S
D916	8-719-800-33	DIODE SLP162B
D917	8-719-800-33	DIODE SLP162B
D918	8-719-800-33	DIODE SLP162B
D919	8-719-936-56	DIODE DAN209S
D920	8-719-936-56	DIODE DAN209S
D921	8-719-936-56	DIODE DAN209S
D922	8-719-936-56	DIODE DAN209S
D923	8-719-936-56	DIODE DAN209S
D924	8-719-936-56	DIODE DAN209S
D925	8-719-936-56	DIODE DAN209S
D926	8-719-911-19	DIODE 1SS119
D927	8-719-933-28	DIODE DAP209S
D928	8-719-933-28	DIODE DAP209S
D929	8-719-911-19	DIODE 1SS119
D930	8-719-911-19	DIODE 1SS119
D931	8-719-911-19	DIODE 1SS119
D932	8-719-933-28	DIODE DAP209S
D933	8-719-911-19	DIODE 1SS119
D934	8-719-911-19	DIODE 1SS119
D935	8-719-933-28	DIODE DAP209S
D936	8-719-933-28	DIODE DAP209S
D937	8-719-948-16	DIODE SLP278B
D938	8-719-948-16	DIODE SLP278B
D939	8-719-948-16	DIODE SLP278B
D940	8-719-948-16	DIODE SLP278B
D941	8-719-948-16	DIODE SLP278B
D942	8-719-948-16	DIODE SLP278B
D943	8-719-948-16	DIODE SLP278B
D944	8-719-948-16	DIODE SLP278B
D945	8-719-948-16	DIODE SLP278B
D947	8-719-936-56	DIODE DAN209S
D949	8-719-911-19	DIODE 1SS119
D950	8-719-936-56	DIODE DAN209S
D951	8-719-911-19	DIODE 1SS119
D952	8-719-911-19	DIODE 1SS119
D953	8-719-936-56	DIODE DAN209S
F451	△.1-532-259-00	FUSE, TIME-LAG (T1.6A)
F452	△.1-532-259-00	FUSE, TIME-LAG (T1.6A)
H601	8-719-800-18	DIODE THS103A
H602	8-719-800-18	DIODE THS103A
H701	8-719-800-18	DIODE THS103A
H702	8-719-800-18	DIODE THS103A
HP901	X-3315-027-1	(DECK-A)...HEAD, MAGNETIC (PLAYBACK)
HP902	X-3315-027-1	(DECK-B)...HEAD, MAGNETIC (PLAYBACK)
HP903	8-825-659-00	(DECK-A)...HEAD, MONITOR
HP904	8-825-659-00	(DECK-B)...HEAD, MONITOR
HRP901	1-543-498-11	(DECK-A)...HEAD, MAGNETIC (REC/PB)
HRP902	1-543-498-11	(DECK-B)...HEAD, MAGNETIC (REC/PB)
IC101	8-759-745-61	IC NJM45600-D
IC102	8-759-745-61	IC NJM45600-D
IC103	8-759-745-61	IC NJM45600-D

Note:
 The components identified by mark Δ or dotted line with mark Δ are critical for safety. Replace only with part number specified.

Ref.No.	Part No.	Description
IC104	8-759-745-61	IC NJM45600-D
IC105	8-759-140-66	IC UPD40668C
IC106	8-759-140-66	IC UPD40668C
IC107	8-759-140-66	IC UPD40668C
IC108	8-759-140-66	IC UPD40668C
IC109	8-759-745-61	IC NJM45600-D
IC110	8-759-745-61	IC NJM45600-D
IC111	8-759-745-61	IC NJM45600-D
IC112	8-759-745-61	IC NJM45600-D
IC113	8-759-140-66	IC UPD40668C
IC114	8-759-140-66	IC UPD40668C
IC115	8-759-140-66	IC UPD40668C
IC116	8-759-140-66	IC UPD40668C
IC117	8-759-145-58	IC UPC4558C
IC118	8-759-145-58	IC UPC4558C
IC119	8-759-145-58	IC UPC4558C
IC120	8-759-145-58	IC UPC4558C
IC121	8-759-145-58	IC UPC4558C
IC122	8-759-157-52	IC UPC575C
IC123	8-759-145-58	IC UPC4558C
IC124	8-759-745-61	IC NJM45600-D
IC125	8-759-145-58	IC UPC4558C
IC126	8-759-745-61	IC NJM45600-D
IC127	8-759-103-93	IC UPC393C
IC128	8-759-940-94	IC MSM4094RS
IC129	8-759-140-66	IC UPD40668C
IC130	8-759-140-66	IC UPD40668C
IC131	8-759-700-06	IC NJM7812B
IC132	8-759-278-06	IC TA78L006AP
IC133	8-759-179-12	IC UPC7912H
IC134	8-759-745-61	IC NJM45600-D
IC135	8-759-745-61	IC NJM45600-D
IC601	8-759-145-58	IC UPC4558C
IC602	8-759-145-58	IC UPC4558C
IC603	8-759-600-69	IC CX-069A
IC701	8-759-145-58	IC UPC4558C
IC702	8-759-145-58	IC UPC4558C
IC703	8-759-600-69	IC CX-069A
IC901	8-759-141-26	IC UPD75108CW-151
IC902	8-759-133-90	IC UPC339C
IC903	8-759-929-11	IC 8A618
IC904	8-759-929-11	IC 8A618
IC905	8-759-203-95	IC T062104P
J101	1-507-806-41	JACK (EARPHONE)
J102	1-507-922-00	JACK (REMOTE)
J103	1-565-114-11	JACK, MODULAR (DISPLAY)
J104	1-507-826-00	JACK, LARGE TYPE (PA)
J105	1-565-173-11	CONNECTOR, D-SUB (MOUNT TYPE 15P (CONTROL UNIT))
J901	*1-561-533-00	SOCKET, CONNECTOR 12P (FOOT SWITCH)
J902	1-562-299-21	CONNECTOR (RECEPTACLE) (MIC CH1)
J903	1-562-299-21	CONNECTOR (RECEPTACLE) (MIC CH1)
J904	1-562-299-21	CONNECTOR (RECEPTACLE) (MIC CH2)
J905	1-562-299-21	CONNECTOR (RECEPTACLE) (MIC CH2)
J906	1-562-299-21	CONNECTOR (RECEPTACLE) (MIC CH3)
J907	1-562-299-21	CONNECTOR (RECEPTACLE) (MIC CH3)
J908	1-562-299-21	CONNECTOR (RECEPTACLE) (MIC CH4)
J909	1-562-299-21	CONNECTOR (RECEPTACLE) (MIC CH4)

Ref.No.	Part No.	Description
L101	1-433-220-00	TRANSFORMER, BIAS
L201	1-433-220-00	TRANSFORMER, BIAS
L601	1-462-196-21	(DECK-A)...COIL, MOTOR (STATOR)
L602	1-462-196-21	(DECK-A)...COIL, MOTOR (STATOR)
L603	1-462-196-21	(DECK-A)...COIL, MOTOR (STATOR)
L604	1-462-196-21	(DECK-A)...COIL, MOTOR (STATOR)
L701	1-462-196-21	(DECK-B)...COIL, MOTOR (STATOR)
L702	1-462-196-21	(DECK-B)...COIL, MOTOR (STATOR)
L703	1-462-196-21	(DECK-B)...COIL, MOTOR (STATOR)
L704	1-462-196-21	(DECK-B)...COIL, MOTOR (STATOR)
ND901	8-719-938-24	DIODE LC-305MK
ND902	8-719-938-24	DIODE LC-305MK
PM601	1-454-179-21	(DECK-A)...SOLENOID, PLUNGER (EJECT)
PM602	1-454-385-11	(DECK-A)...SOLENOID, PLUNGER (FF/REW)
PM603	1-454-385-11	(DECK-A)...SOLENOID, PLUNGER (FWD)
PM701	1-454-179-21	(DECK-B)...SOLENOID, PLUNGER (EJECT)
PM702	1-454-385-11	(DECK-B)...SOLENOID, PLUNGER (FF/REW)
PM703	1-454-385-11	(DECK-B)...SOLENOID, PLUNGER (FWD)
Q102	8-729-811-24	TRANSISTOR 2SD1012
Q103	8-729-117-54	TRANSISTOR 2SA1175
Q151	8-729-802-34	TRANSISTOR 2SD1388
Q152	8-729-900-36	TRANSISTOR DTC124ES
Q153	8-729-600-27	TRANSISTOR 2SC634SP
Q154	8-729-900-36	TRANSISTOR DTC124ES
Q155	8-729-900-65	TRANSISTOR DTA144ES
Q156	8-729-900-65	TRANSISTOR DTA144ES
Q157	8-729-900-89	TRANSISTOR DTC144ES
Q158	8-729-600-27	TRANSISTOR 2SC634SP
Q160	8-729-600-27	TRANSISTOR 2SC634SP
Q202	8-729-811-24	TRANSISTOR 2SD1012
Q203	8-729-117-54	TRANSISTOR 2SA1175
Q251	8-729-802-34	TRANSISTOR 2SD1388
Q252	8-729-900-36	TRANSISTOR DTC124ES
Q253	8-729-600-27	TRANSISTOR 2SC634SP
Q254	8-729-900-36	TRANSISTOR DTC124ES
Q255	8-729-900-65	TRANSISTOR DTA144ES
Q256	8-729-900-65	TRANSISTOR DTA144ES
Q257	8-729-900-89	TRANSISTOR DTC144ES
Q258	8-729-600-27	TRANSISTOR 2SC634SP
Q260	8-729-600-27	TRANSISTOR 2SC634SP
Q302	8-729-811-24	TRANSISTOR 2SD1012
Q303	8-729-117-54	TRANSISTOR 2SA1175
Q351	8-729-600-27	TRANSISTOR 2SC634SP
Q352	8-729-811-24	TRANSISTOR 2SD1012
Q353	8-729-811-24	TRANSISTOR 2SD1012
Q402	8-729-811-24	TRANSISTOR 2SD1012
Q403	8-729-117-54	TRANSISTOR 2SA1175
Q451	8-729-600-27	TRANSISTOR 2SC634SP
Q452	8-729-600-27	TRANSISTOR 2SC634SP
Q453	8-729-600-27	TRANSISTOR 2SC634SP
Q454	8-729-900-89	TRANSISTOR DTC144ES
Q455	8-729-117-54	TRANSISTOR 2SA1175
Q502	8-729-811-24	TRANSISTOR 2SD1012
Q503	8-729-117-54	TRANSISTOR 2SA1175
Q602	8-729-811-24	TRANSISTOR 2SD1012
Q603	8-729-117-54	TRANSISTOR 2SA1175
Q651	8-729-177-43	TRANSISTOR 2SD774
Q652	8-729-374-02	TRANSISTOR 2SB740

Ref.No.	Part No.	Description
Q653	8-729-177-43	TRANSISTOR 2SD774
Q654	8-729-374-02	TRANSISTOR 2SB740
Q655	8-729-600-27	TRANSISTOR 2SC634SP
Q657	8-729-117-54	TRANSISTOR 2SA1175
Q658	8-729-900-61	TRANSISTOR DTA114ES
Q660	8-729-900-74	TRANSISTOR DTC143TS
Q661	8-729-900-89	TRANSISTOR DTC144ES
Q662	8-729-900-89	TRANSISTOR DTC144ES
Q663	8-729-102-10	TRANSISTOR PH104
Q664	8-729-102-10	TRANSISTOR PH104
Q665	8-729-801-83	TRANSISTOR 2SB1013
Q667	8-729-900-36	TRANSISTOR DTC124ES
Q668	8-729-900-36	TRANSISTOR DTC124ES
Q669	8-729-900-36	TRANSISTOR DTC124ES
Q671	8-729-900-61	TRANSISTOR DTA114ES
Q672	8-729-900-61	TRANSISTOR DTA114ES
Q673	8-729-801-93	TRANSISTOR 2SD1387
Q674	8-729-801-93	TRANSISTOR 2SD1387
Q677	8-729-801-83	TRANSISTOR 2SB1013
Q702	8-729-811-24	TRANSISTOR 2SD1012
Q703	8-729-117-54	TRANSISTOR 2SA1175
Q751	8-729-177-43	TRANSISTOR 2SD774
Q752	8-729-374-02	TRANSISTOR 2SB740
Q753	8-729-177-43	TRANSISTOR 2SD774
Q754	8-729-374-02	TRANSISTOR 2SB740
Q755	8-729-600-27	TRANSISTOR 2SC634SP
Q756	8-729-900-61	TRANSISTOR DTA114ES
Q757	8-729-117-54	TRANSISTOR 2SA1175
Q758	8-729-117-54	TRANSISTOR 2SA1175
Q759	8-729-900-89	TRANSISTOR DTC144ES
Q760	8-729-900-74	TRANSISTOR DTC143TS
Q761	8-729-900-89	TRANSISTOR DTC144ES
Q762	8-729-900-89	TRANSISTOR DTC144ES
Q763	8-729-102-10	TRANSISTOR PH104
Q764	8-729-102-10	TRANSISTOR PH104
Q765	8-729-801-83	TRANSISTOR 2SB1013
Q767	8-729-900-36	TRANSISTOR DTC124ES
Q768	8-729-900-36	TRANSISTOR DTC124ES
Q769	8-729-900-36	TRANSISTOR DTC124ES
Q770	8-729-900-65	TRANSISTOR DTA144ES
Q771	8-729-900-61	TRANSISTOR DTA114ES
Q772	8-729-900-61	TRANSISTOR DTA114ES
Q773	8-729-801-93	TRANSISTOR 2SD1387
Q774	8-729-801-93	TRANSISTOR 2SD1387
Q775	8-729-900-89	TRANSISTOR DTC144ES
Q776	8-729-801-93	TRANSISTOR 2SD1387
Q802	8-729-811-24	TRANSISTOR 2SD1012
Q803	8-729-117-54	TRANSISTOR 2SA1175
Q904	8-729-900-65	TRANSISTOR DTA144ES
Q905	8-729-900-65	TRANSISTOR DTA144ES
Q906	8-729-900-65	TRANSISTOR DTA144ES
Q907	8-729-900-65	TRANSISTOR DTA144ES
Q908	8-729-900-65	TRANSISTOR DTA144ES
Q909	8-729-900-65	TRANSISTOR DTA144ES
Q910	8-729-900-80	TRANSISTOR DTC114ES
Q912	8-729-600-27	TRANSISTOR 2SC634SP
Q915	8-729-600-27	TRANSISTOR 2SC634SP

Ref.No.	Part No.	Description				
Q916	8-729-900-61	TRANSISTOR DTA114ES				
Q917	8-729-600-27	TRANSISTOR 2SC634SP				
Q918	8-729-900-61	TRANSISTOR DTA114ES				
Q919	8-729-600-27	TRANSISTOR 2SC634SP				
Q920	8-729-600-27	TRANSISTOR 2SC634SP				
Q921	8-729-117-54	TRANSISTOR 2SA1175				
Q922	8-729-117-54	TRANSISTOR 2SA1175				
Q923	8-729-900-80	TRANSISTOR DTC114ES				
Q924	8-729-900-36	TRANSISTOR DTC124ES				
Q925	8-729-900-36	TRANSISTOR DTC124ES				
Q926	8-729-900-89	TRANSISTOR DTC144ES				
Q927	8-729-900-89	TRANSISTOR DTC144ES				
R101	1-249-437-11	CARBON	47K	5%	1/4W	
R102	1-249-410-11	CARBON	270	5%	1/4W	
R103	1-249-437-11	CARBON	47K	5%	1/4W	
R104	1-249-437-11	CARBON	47K	5%	1/4W	
R105	1-249-429-11	CARBON	10K	5%	1/4W	
R110	1-249-429-11	CARBON	10K	5%	1/4W	
R111	1-249-437-11	CARBON	47K	5%	1/4W	
R112	1-249-433-11	CARBON	22K	5%	1/4W	
R113	1-249-438-11	CARBON	56K	5%	1/4W	
R114	1-249-439-11	CARBON	68K	5%	1/4W	
R115	1-249-410-11	CARBON	270	5%	1/4W	
R116	1-249-407-11	CARBON	150	5%	1/4W	
R117	1-249-417-11	CARBON	1K	5%	1/4W	
R118	1-249-405-11	CARBON	100	5%	1/4W	
R119	1-249-433-11	CARBON	22K	5%	1/4W	
R120	1-249-425-11	CARBON	4.7K	5%	1/4W	
R121	1-249-441-11	CARBON	100K	5%	1/4W	
R122	1-249-419-11	CARBON	1.5K	5%	1/4W	
R123	1-215-483-00	CARBON	390K	5%	1/4W	
R124	1-249-417-11	CARBON	1K	5%	1/4W	
R125	1-249-433-11	CARBON	22K	5%	1/4W	
R126	1-249-417-11	CARBON	1K	5%	1/4W	
R127	1-249-429-11	CARBON	10K	5%	1/4W	
R128	1-249-441-11	CARBON	100K	5%	1/4W	
R129	1-249-429-11	CARBON	10K	5%	1/4W	
R130	1-249-435-11	CARBON	33K	5%	1/4W	
R131	1-249-423-11	CARBON	3.3K	5%	1/4W	
R132	1-249-423-11	CARBON	3.3K	5%	1/4W	
R133	1-249-439-11	CARBON	68K	5%	1/4W	
R134	1-249-434-11	CARBON	27K	5%	1/4W	
R135	1-249-423-11	CARBON	3.3K	5%	1/4W	
R151	1-249-426-11	CARBON	5.6K	5%	1/4W	
R152	1-249-424-11	CARBON	3.9K	5%	1/4W	
R153	1-249-422-11	CARBON	2.7K	5%	1/4W	
R154	1-249-410-11	CARBON	270	5%	1/4W	
R155	1-249-437-11	CARBON	47K	5%	1/4W	
R156	1-249-409-11	CARBON	220	5%	1/4W	
R157	1-249-404-00	CARBON	82	5%	1/4W	
R158	1-249-437-11	CARBON	47K	5%	1/4W	
R159	1-249-425-11	CARBON	4.7K	5%	1/4W	
R161	1-249-441-11	CARBON	100K	5%	1/4W	
R162	1-249-433-11	CARBON	22K	5%	1/4W	
R163	1-249-429-11	CARBON	10K	5%	1/4W	
R164	1-247-887-00	CARBON	220K	5%	1/4W	
R165	1-249-413-11	CARBON	470	5%	1/4W	

Ref.No.	Part No.	Description					
R166	1-249-441-11	CARBON	100K	5%	1/4W		
R167	1-249-413-11	CARBON	470	5%	1/4W		
R168	1-249-417-11	CARBON	1K	5%	1/4W		
R169	1-249-429-11	CARBON	10K	5%	1/4W		
R170	1-249-431-11	CARBON	15K	5%	1/4W		
R171	1-249-441-11	CARBON	100K	5%	1/4W		
R172	1-249-437-11	CARBON	47K	5%	1/4W		
R173	1-249-417-11	CARBON	1K	5%	1/4W		
R174	1-249-429-11	CARBON	10K	5%	1/4W		
R175	1-249-441-11	CARBON	100K	5%	1/4W		
R176	1-249-417-11	CARBON	1K	5%	1/4W		
R177	1-249-421-11	CARBON	2.2K	5%	1/4W		
R178	1-249-413-11	CARBON	470	5%	1/4W		
R179	1-249-429-11	CARBON	10K	5%	1/4W		
R201	1-249-437-11	CARBON	47K	5%	1/4W		
R202	1-249-410-11	CARBON	270	5%	1/4W		
R203	1-249-437-11	CARBON	47K	5%	1/4W		
R204	1-249-437-11	CARBON	47K	5%	1/4W		
R205	1-249-429-11	CARBON	10K	5%	1/4W		
R210	1-249-429-11	CARBON	10K	5%	1/4W		
R211	1-249-437-11	CARBON	47K	5%	1/4W		
R212	1-249-433-11	CARBON	22K	5%	1/4W		
R213	1-249-438-11	CARBON	56K	5%	1/4W		
R214	1-249-439-11	CARBON	68K	5%	1/4W		
R215	1-249-410-11	CARBON	270	5%	1/4W		
R216	1-249-407-11	CARBON	150	5%	1/4W		
R217	1-249-417-11	CARBON	1K	5%	1/4W		
R218	1-249-405-11	CARBON	100	5%	1/4W		
R219	1-249-433-11	CARBON	22K	5%	1/4W		
R220	1-249-425-11	CARBON	4.7K	5%	1/4W		
R221	1-249-441-11	CARBON	100K	5%	1/4W		
R222	1-249-419-11	CARBON	1.5K	5%	1/4W		
R223	1-215-483-00	CARBON	390K	5%	1/4W		
R224	1-249-417-11	CARBON	1K	5%	1/4W		
R225	1-249-433-11	CARBON	22K	5%	1/4W		
R226	1-249-417-11	CARBON	1K	5%	1/4W		
R227	1-249-429-11	CARBON	10K	5%	1/4W		
R228	1-249-441-11	CARBON	100K	5%	1/4W		
R229	1-249-429-11	CARBON	10K	5%	1/4W		
R230	1-249-435-11	CARBON	33K	5%	1/4W		
R231	1-249-423-11	CARBON	3.3K	5%	1/4W		
R232	1-249-423-11	CARBON	3.3K	5%	1/4W		
R233	1-249-439-11	CARBON	68K	5%	1/4W		
R234	1-249-434-11	CARBON	27K	5%	1/4W		
R235	1-249-423-11	CARBON	3.3K	5%	1/4W		
R251	1-249-426-11	CARBON	5.6K	5%	1/4W		
R252	1-249-424-11	CARBON	3.9K	5%	1/4W		
R253	1-249-422-11	CARBON	2.7K	5%	1/4W		
R254	1-249-410-11	CARBON	270	5%	1/4W		
R255	1-249-437-11	CARBON	47K	5%	1/4W		
R256	1-249-409-11	CARBON	220	5%	1/4W		
R257	1-249-404-00	CARBON	82	5%	1/4W		
R258	1-249-437-11	CARBON	47K	5%	1/4W		
R259	1-249-425-11	CARBON	4.7K	5%	1/4W		
R261	1-249-441-11	CARBON	100K	5%	1/4W		
R262	1-249-433-11	CARBON	22K	5%	1/4W		
R263	1-249-429-11	CARBON	10K	5%	1/4W		
R264	1-247-887-00	CARBON	220K	5%	1/4W		
R265	1-249-413-11	CARBON	470	5%	1/4W		
R266	1-249-441-11	CARBON	100K	5%	1/4W		
R267	1-249-413-11	CARBON	470	5%	1/4W		
R268	1-249-417-11	CARBON	1K	5%	1/4W		
R269	1-249-429-11	CARBON	10K	5%	1/4W		
R270	1-249-431-11	CARBON	15K	5%	1/4W		
R271	1-249-441-11	CARBON	100K	5%	1/4W		
R272	1-249-437-11	CARBON	47K	5%	1/4W		
R273	1-249-417-11	CARBON	1K	5%	1/4W		
R274	1-249-429-11	CARBON	10K	5%	1/4W		
R275	1-249-441-11	CARBON	100K	5%	1/4W		
R276	1-249-417-11	CARBON	1K	5%	1/4W		
R277	1-249-421-11	CARBON	2.2K	5%	1/4W		
R278	1-249-413-11	CARBON	470	5%	1/4W		
R279	1-249-429-11	CARBON	10K	5%	1/4W		
R301	1-249-437-11	CARBON	47K	5%	1/4W		
R302	1-249-410-11	CARBON	270	5%	1/4W		
R303	1-249-437-11	CARBON	47K	5%	1/4W		
R304	1-249-437-11	CARBON	47K	5%	1/4W		
R305	1-249-429-11	CARBON	10K	5%	1/4W		
R310	1-249-429-11	CARBON	10K	5%	1/4W		
R311	1-249-437-11	CARBON	47K	5%	1/4W		
R312	1-249-433-11	CARBON	22K	5%	1/4W		
R313	1-249-438-11	CARBON	56K	5%	1/4W		
R314	1-249-439-11	CARBON	68K	5%	1/4W		
R315	1-249-410-11	CARBON	270	5%	1/4W		
R316	1-249-407-11	CARBON	150	5%	1/4W		
R317	1-249-417-11	CARBON	1K	5%	1/4W		
R318	1-249-405-11	CARBON	100	5%	1/4W		
R319	1-249-433-11	CARBON	22K	5%	1/4W		
R320	1-249-425-11	CARBON	4.7K	5%	1/4W		
R321	1-249-441-11	CARBON	100K	5%	1/4W		
R322	1-249-419-11	CARBON	1.5K	5%	1/4W		
R323	1-215-483-00	CARBON	390K	5%	1/4W		
R324	1-249-417-11	CARBON	1K	5%	1/4W		
R325	1-249-433-11	CARBON	22K	5%	1/4W		
R326	1-249-417-11	CARBON	1K	5%	1/4W		
R327	1-249-429-11	CARBON	10K	5%	1/4W		
R328	1-249-441-11	CARBON	100K	5%	1/4W		
R329	1-249-429-11	CARBON	10K	5%	1/4W		
R330	1-249-435-11	CARBON	33K	5%	1/4W		
R331	1-249-423-11	CARBON	3.3K	5%	1/4W		
R332	1-249-423-11	CARBON	3.3K	5%	1/4W		
R333	1-249-439-11	CARBON	68K	5%	1/4W		
R334	1-249-434-11	CARBON	27K	5%	1/4W		
R335	1-249-423-11	CARBON	3.3K	5%	1/4W		
R351	1-249-405-11	CARBON	100	5%	1/4W		
R352	1-249-405-11	CARBON	100	5%	1/4W		
R353	1-249-405-11	CARBON	100	5%	1/4W		
R354	1-249-405-11	CARBON	100	5%	1/4W		
R356	1-249-409-11	CARBON	220	5%	1/4W		
R357	1-249-409-11	CARBON	220	5%	1/4W		
R360	1-249-437-11	CARBON	47K	5%	1/4W		
R361	1-247-883-00	CARBON	150K	5%	1/4W		
R362	1-249-438-11	CARBON	56K	5%	1/4W		
R363	1-249-434-11	CARBON	27K	5%	1/4W		

Ref.No.	Part No.	Description			
R364	1-249-433-11	CARBON	22K	5%	1/4W
R365	1-249-437-11	CARBON	47K	5%	1/4W
R366	1-249-431-11	CARBON	15K	5%	1/4W
R367	1-249-433-11	CARBON	22K	5%	1/4W
R368	1-249-441-11	CARBON	100K	5%	1/4W
R369	1-249-441-11	CARBON	100K	5%	1/4W
R370	1-249-433-11	CARBON	22K	5%	1/4W
R371	1-249-425-11	CARBON	4.7K	5%	1/4W
R372	1-249-433-11	CARBON	22K	5%	1/4W
R373	1-249-437-11	CARBON	47K	5%	1/4W
R374	1-249-433-11	CARBON	22K	5%	1/4W
R375	1-249-437-11	CARBON	47K	5%	1/4W
R376	1-249-437-11	CARBON	47K	5%	1/4W
R377	1-247-883-00	CARBON	150K	5%	1/4W
R378	1-247-881-00	CARBON	120K	5%	1/4W
R379	1-249-438-11	CARBON	56K	5%	1/4W
R380	1-249-409-11	CARBON	220	5%	1/4W
R381	1-249-411-11	CARBON	330	5%	1/4W
R382	1-249-405-11	CARBON	100	5%	1/4W
R383	1-249-441-11	CARBON	100K	5%	1/4W
R384	1-249-429-11	CARBON	10K	5%	1/4W
R385	1-249-437-11	CARBON	47K	5%	1/4W
R386	1-249-433-11	CARBON	22K	5%	1/4W
R387	1-249-429-11	CARBON	10K	5%	1/4W
R388	1-249-429-11	CARBON	10K	5%	1/4W
R389	1-249-434-11	CARBON	27K	5%	1/4W
R390	1-249-429-11	CARBON	10K	5%	1/4W
R391	1-249-437-11	CARBON	47K	5%	1/4W
R392	1-249-429-11	CARBON	10K	5%	1/4W
R393	1-249-437-11	CARBON	47K	5%	1/4W
R394	1-249-425-11	CARBON	4.7K	5%	1/4W
R395	1-249-441-11	CARBON	100K	5%	1/4W
R396	1-247-887-00	CARBON	220K	5%	1/4W
R397	1-249-417-11	CARBON	1K	5%	1/4W
R398	1-249-437-11	CARBON	47K	5%	1/4W
R401	1-249-437-11	CARBON	47K	5%	1/4W
R402	1-249-410-11	CARBON	270	5%	1/4W
R403	1-249-437-11	CARBON	47K	5%	1/4W
R404	1-249-437-11	CARBON	47K	5%	1/4W
R405	1-249-429-11	CARBON	10K	5%	1/4W
R410	1-249-429-11	CARBON	10K	5%	1/4W
R411	1-249-437-11	CARBON	47K	5%	1/4W
R412	1-249-433-11	CARBON	22K	5%	1/4W
R413	1-249-438-11	CARBON	56K	5%	1/4W
R414	1-249-439-11	CARBON	68K	5%	1/4W
R415	1-249-410-11	CARBON	270	5%	1/4W
R416	1-249-407-11	CARBON	150	5%	1/4W
R417	1-249-417-11	CARBON	1K	5%	1/4W
R418	1-249-405-11	CARBON	100	5%	1/4W
R419	1-249-433-11	CARBON	22K	5%	1/4W
R420	1-249-425-11	CARBON	4.7K	5%	1/4W
R421	1-249-441-11	CARBON	100K	5%	1/4W
R422	1-249-419-11	CARBON	1.5K	5%	1/4W
R423	1-215-483-00	CARBON	390K	5%	1/4W
R424	1-249-417-11	CARBON	1K	5%	1/4W
R425	1-249-433-11	CARBON	22K	5%	1/4W
R426	1-249-417-11	CARBON	1K	5%	1/4W
R427	1-249-429-11	CARBON	10K	5%	1/4W

Ref.No.	Part No.	Description			
R428	1-249-441-11	CARBON	100K	5%	1/4W
R429	1-249-429-11	CARBON	10K	5%	1/4W
R430	1-249-435-11	CARBON	33K	5%	1/4W
R431	1-249-423-11	CARBON	3.3K	5%	1/4W
R432	1-249-423-11	CARBON	3.3K	5%	1/4W
R433	1-249-439-11	CARBON	68K	5%	1/4W
R434	1-249-434-11	CARBON	27K	5%	1/4W
R435	1-249-423-11	CARBON	3.3K	5%	1/4W
R451	1-249-441-11	CARBON	100K	5%	1/4W
R452	1-249-405-11	CARBON	100	5%	1/4W
R453	1-249-405-11	CARBON	100	5%	1/4W
R454	1-249-405-11	CARBON	100	5%	1/4W
R455	1-249-437-11	CARBON	47K	5%	1/4W
R456	1-249-437-11	CARBON	47K	5%	1/4W
R457	1-249-437-11	CARBON	47K	5%	1/4W
R458	1-249-441-11	CARBON	100K	5%	1/4W
R459	1-249-429-11	CARBON	10K	5%	1/4W
R460	1-249-417-11	CARBON	1K	5%	1/4W
R461	1-249-417-11	CARBON	1K	5%	1/4W
R462	1-249-441-11	CARBON	100K	5%	1/4W
R463	1-249-425-11	CARBON	4.7K	5%	1/4W
R464	1-249-425-11	CARBON	4.7K	5%	1/4W
R465	1-249-425-11	CARBON	4.7K	5%	1/4W
R466	1-249-425-11	CARBON	4.7K	5%	1/4W
R501	1-249-437-11	CARBON	47K	5%	1/4W
R502	1-249-410-11	CARBON	270	5%	1/4W
R503	1-249-437-11	CARBON	47K	5%	1/4W
R504	1-249-437-11	CARBON	47K	5%	1/4W
R505	1-249-429-11	CARBON	10K	5%	1/4W
R510	1-249-429-11	CARBON	10K	5%	1/4W
R511	1-249-437-11	CARBON	47K	5%	1/4W
R512	1-249-433-11	CARBON	22K	5%	1/4W
R513	1-249-438-11	CARBON	56K	5%	1/4W
R514	1-249-439-11	CARBON	68K	5%	1/4W
R515	1-249-410-11	CARBON	270	5%	1/4W
R516	1-249-407-11	CARBON	150	5%	1/4W
R517	1-249-417-11	CARBON	1K	5%	1/4W
R518	1-249-405-11	CARBON	100	5%	1/4W
R519	1-249-433-11	CARBON	22K	5%	1/4W
R520	1-249-425-11	CARBON	4.7K	5%	1/4W
R521	1-249-441-11	CARBON	100K	5%	1/4W
R522	1-249-419-11	CARBON	1.5K	5%	1/4W
R523	1-215-483-00	CARBON	390K	5%	1/4W
R524	1-249-417-11	CARBON	1K	5%	1/4W
R525	1-249-433-11	CARBON	22K	5%	1/4W
R526	1-249-417-11	CARBON	1K	5%	1/4W
R527	1-249-429-11	CARBON	10K	5%	1/4W
R528	1-249-441-11	CARBON	100K	5%	1/4W
R529	1-249-429-11	CARBON	10K	5%	1/4W
R601	1-249-437-11	CARBON	47K	5%	1/4W
R602	1-249-410-11	CARBON	270	5%	1/4W
R603	1-249-437-11	CARBON	47K	5%	1/4W
R604	1-249-437-11	CARBON	47K	5%	1/4W
R605	1-249-429-11	CARBON	10K	5%	1/4W
R610	1-249-429-11	CARBON	10K	5%	1/4W
R611	1-249-437-11	CARBON	47K	5%	1/4W
R612	1-249-433-11	CARBON	22K	5%	1/4W

Ref.No.	Part No.	Description			
R613	1-249-438-11	CARBON	56K	5%	1/4W
R614	1-249-439-11	CARBON	68K	5%	1/4W
R615	1-249-410-11	CARBON	270	5%	1/4W
R616	1-249-407-11	CARBON	150	5%	1/4W
R617	1-249-417-11	CARBON	1K	5%	1/4W
R618	1-249-405-11	CARBON	100	5%	1/4W
R619	1-249-433-11	CARBON	22K	5%	1/4W
R620	1-249-425-11	CARBON	4.7K	5%	1/4W
R621	1-249-441-11	CARBON	100K	5%	1/4W
R622	1-249-419-11	CARBON	1.5K	5%	1/4W
R623	1-215-483-00	CARBON	390K	5%	1/4W
R624	1-249-417-11	CARBON	1K	5%	1/4W
R625	1-249-433-11	CARBON	22K	5%	1/4W
R626	1-249-417-11	CARBON	1K	5%	1/4W
R627	1-249-429-11	CARBON	10K	5%	1/4W
R628	1-249-441-11	CARBON	100K	5%	1/4W
R629	1-249-429-11	CARBON	10K	5%	1/4W
R648	1-249-433-11	CARBON	22K	5%	1/4W
R651	1-249-411-11	CARBON	330	5%	1/4W
R652	1-249-411-11	CARBON	330	5%	1/4W
R653	1-249-411-11	CARBON	330	5%	1/4W
R654	1-249-424-11	CARBON	3.9K	5%	1/4W
R655	1-215-489-00	CARBON	680K	5%	1/4W
R656	1-249-424-11	CARBON	3.9K	5%	1/4W
R657	1-215-489-00	CARBON	680K	5%	1/4W
R658	1-249-405-11	CARBON	100	5%	1/4W
R659	1-249-411-11	CARBON	330	5%	1/4W
R660	1-249-411-11	CARBON	330	5%	1/4W
R661	1-249-411-11	CARBON	330	5%	1/4W
R662	1-249-424-11	CARBON	3.9K	5%	1/4W
R663	1-215-489-00	CARBON	680K	5%	1/4W
R664	1-249-405-11	CARBON	100	5%	1/4W
R665	1-215-489-00	CARBON	680K	5%	1/4W
R666	1-249-424-11	CARBON	3.9K	5%	1/4W
R667	1-249-419-11	CARBON	1.5K	5%	1/4W
R668	1-247-883-00	CARBON	150K	5%	1/4W
R669	1-249-441-11	CARBON	100K	5%	1/4W
R670	1-249-441-11	CARBON	100K	5%	1/4W
R671	1-249-441-11	CARBON	100K	5%	1/4W
R672	1-249-441-11	CARBON	100K	5%	1/4W
R673	1-249-441-11	CARBON	100K	5%	1/4W
R674	1-249-437-11	CARBON	47K	5%	1/4W
R675	1-249-429-11	CARBON	10K	5%	1/4W
R677	1-249-430-11	CARBON	12K	5%	1/4W
R679	1-249-429-11	CARBON	10K	5%	1/4W
R680	1-249-434-11	CARBON	27K	5%	1/4W
R681	1-249-434-11	CARBON	27K	5%	1/4W
R683	1-249-413-11	CARBON	470	5%	1/4W
R684	1-249-431-11	CARBON	15K	5%	1/4W
R685	1-249-431-11	CARBON	15K	5%	1/4W
R686	1-249-441-11	CARBON	100K	5%	1/4W
R687	1-249-421-11	CARBON	2.2K	5%	1/4W
R689	1-249-433-11	CARBON	22K	5%	1/4W
R690	1-249-433-11	CARBON	22K	5%	1/4W
R691	1-249-423-11	CARBON	3.3K	5%	1/4W
R692	1-249-441-11	CARBON	100K	5%	1/4W

Ref.No.	Part No.	Description			
R693	1-249-423-11	CARBON	3.3K	5%	1/4W
R694	1-249-441-11	CARBON	100K	5%	1/4W
R696	1-215-911-11	METAL OXIDE	100	5%	3W F
R697	1-249-441-11	CARBON	100K	5%	1/4W
R698	1-249-419-11	CARBON	1.5K	5%	1/4W
R701	1-249-437-11	CARBON	47K	5%	1/4W
R702	1-249-410-11	CARBON	270	5%	1/4W
R703	1-249-437-11	CARBON	47K	5%	1/4W
R704	1-249-437-11	CARBON	47K	5%	1/4W
R705	1-249-429-11	CARBON	10K	5%	1/4W
R710	1-249-429-11	CARBON	10K	5%	1/4W
R711	1-249-437-11	CARBON	47K	5%	1/4W
R712	1-249-433-11	CARBON	22K	5%	1/4W
R713	1-249-438-11	CARBON	56K	5%	1/4W
R714	1-249-439-11	CARBON	68K	5%	1/4W
R715	1-249-410-11	CARBON	270	5%	1/4W
R716	1-249-407-11	CARBON	150	5%	1/4W
R717	1-249-417-11	CARBON	1K	5%	1/4W
R718	1-249-405-11	CARBON	100	5%	1/4W
R719	1-249-433-11	CARBON	22K	5%	1/4W
R720	1-249-425-11	CARBON	4.7K	5%	1/4W
R721	1-249-441-11	CARBON	100K	5%	1/4W
R722	1-249-419-11	CARBON	1.5K	5%	1/4W
R723	1-215-483-00	CARBON	390K	5%	1/4W
R724	1-249-417-11	CARBON	1K	5%	1/4W
R725	1-249-433-11	CARBON	22K	5%	1/4W
R726	1-249-417-11	CARBON	1K	5%	1/4W
R727	1-249-429-11	CARBON	10K	5%	1/4W
R728	1-249-441-11	CARBON	100K	5%	1/4W
R729	1-249-429-11	CARBON	10K	5%	1/4W
R748	1-249-433-11	CARBON	22K	5%	1/4W
R749	1-249-441-11	CARBON	100K	5%	1/4W
R750	1-249-441-11	CARBON	100K	5%	1/4W
R751	1-249-411-11	CARBON	330	5%	1/4W
R752	1-249-411-11	CARBON	330	5%	1/4W
R753	1-249-411-11	CARBON	330	5%	1/4W
R754	1-249-424-11	CARBON	3.9K	5%	1/4W
R755	1-215-489-00	CARBON	680K	5%	1/4W
R756	1-249-424-11	CARBON	3.9K	5%	1/4W
R757	1-215-489-00	CARBON	680K	5%	1/4W
R758	1-249-405-11	CARBON	100	5%	1/4W
R759	1-249-411-11	CARBON	330	5%	1/4W
R760	1-249-411-11	CARBON	330	5%	1/4W
R761	1-249-411-11	CARBON	330	5%	1/4W
R762	1-249-424-11	CARBON	3.9K	5%	1/4W
R763	1-215-489-00	CARBON	680K	5%	1/4W
R764	1-249-405-11	CARBON	100	5%	1/4W
R765	1-215-489-00	CARBON	680K	5%	1/4W
R766	1-249-424-11	CARBON	3.9K	5%	1/4W
R767	1-249-419-11	CARBON	1.5K	5%	1/4W
R768	1-247-883-00	CARBON	150K	5%	1/4W
R769	1-249-441-11	CARBON	100K	5%	1/4W
R770	1-249-441-11	CARBON	100K	5%	1/4W
R771	1-249-441-11	CARBON	100K	5%	1/4W
R772	1-249-441-11	CARBON	100K	5%	1/4W
R773	1-249-441-11	CARBON	100K	5%	1/4W
R774	1-249-437-11	CARBON	47K	5%	1/4W

Ref.No.	Part No.	Description			
R775	1-249-429-11	CARBON	10K	5%	1/4W
R776	1-249-428-11	CARBON	8.2K	5%	1/4W
R777	1-249-430-11	CARBON	12K	5%	1/4W
R779	1-249-429-11	CARBON	10K	5%	1/4W
R780	1-249-434-11	CARBON	27K	5%	1/4W
R781	1-249-434-11	CARBON	77K	5%	1/4W
R782	1-249-429-11	CARBON	10K	5%	1/4W
R783	1-249-413-11	CARBON	470	5%	1/4W
R784	1-249-431-11	CARBON	15K	5%	1/4W
R785	1-249-431-11	CARBON	15K	5%	1/4W
R786	1-249-441-11	CARBON	100K	5%	1/4W
R787	1-249-421-11	CARBON	2.2K	5%	1/4W
R789	1-249-433-11	CARBON	22K	5%	1/4W
R790	1-249-433-11	CARBON	22K	5%	1/4W
R791	1-249-423-11	CARBON	3.3K	5%	1/4W
R792	1-249-441-11	CARBON	100K	5%	1/4W
R793	1-249-423-11	CARBON	3.3K	5%	1/4W
R794	1-249-441-11	CARBON	100K	5%	1/4W
R798	1-249-423-11	CARBON	3.3K	5%	1/4W
R799	1-249-441-11	CARBON	100K	5%	1/4W
R801	1-249-437-11	CARBON	47K	5%	1/4W
R802	1-249-410-11	CARBON	270	5%	1/4W
R803	1-249-437-11	CARBON	47K	5%	1/4W
R804	1-249-437-11	CARBON	47K	5%	1/4W
R805	1-249-429-11	CARBON	10K	5%	1/4W
R810	1-249-429-11	CARBON	10K	5%	1/4W
R811	1-249-437-11	CARBON	47K	5%	1/4W
R812	1-249-433-11	CARBON	22K	5%	1/4W
R813	1-249-438-11	CARBON	56K	5%	1/4W
R814	1-249-439-11	CARBON	68K	5%	1/4W
R815	1-249-410-11	CARBON	270	5%	1/4W
R816	1-249-407-11	CARBON	150	5%	1/4W
R817	1-249-417-11	CARBON	1K	5%	1/4W
R818	1-249-405-11	CARBON	100	5%	1/4W
R819	1-249-433-11	CARBON	22K	5%	1/4W
R820	1-249-425-11	CARBON	4.7K	5%	1/4W
R821	1-249-441-11	CARBON	100K	5%	1/4W
R822	1-249-419-11	CARBON	1.5K	5%	1/4W
R823	1-215-483-00	CARBON	390K	5%	1/4W
R824	1-249-417-11	CARBON	1K	5%	1/4W
R825	1-249-433-11	CARBON	22K	5%	1/4W
R826	1-249-417-11	CARBON	1K	5%	1/4W
R827	1-249-429-11	CARBON	10K	5%	1/4W
R828	1-249-441-11	CARBON	100K	5%	1/4W
R829	1-249-429-11	CARBON	10K	5%	1/4W
R901	1-249-437-11	CARBON	47K	5%	1/4W
R902	1-249-417-11	CARBON	1K	5%	1/4W
R904	1-249-437-11	CARBON	47K	5%	1/4W
R905	1-249-417-11	CARBON	1K	5%	1/4W
R907	1-249-437-11	CARBON	47K	5%	1/4W
R908	1-249-417-11	CARBON	1K	5%	1/4W
R910	1-249-437-11	CARBON	47K	5%	1/4W
R911	1-249-437-11	CARBON	47K	5%	1/4W
R912	1-249-429-11	CARBON	10K	5%	1/4W
R913	1-249-429-11	CARBON	10K	5%	1/4W
R914	1-249-421-11	CARBON	2.2K	5%	1/4W



Ref.No.	Part No.	Description			
R915	1-249-417-11	CARBON	1K	5%	1/4W
R916	1-249-437-11	CARBON	47K	5%	1/4W
R917	1-249-437-11	CARBON	47K	5%	1/4W
R918	1-249-437-11	CARBON	47K	5%	1/4W
R919	1-249-437-11	CARBON	47K	5%	1/4W
R920	1-249-429-11	CARBON	10K	5%	1/4W
R921	1-249-417-11	CARBON	1K	5%	1/4W
R923	1-249-437-11	CARBON	47K	5%	1/4W
R924	1-249-441-11	CARBON	100K	5%	1/4W
R925	1-249-433-11	CARBON	22K	5%	1/4W
R926	1-249-441-11	CARBON	100K	5%	1/4W
R927	1-249-433-11	CARBON	22K	5%	1/4W
R929	1-249-437-11	CARBON	47K	5%	1/4W
R931	1-249-441-11	CARBON	100K	5%	1/4W
R932	1-249-425-11	CARBON	4.7K	5%	1/4W
R933	1-249-425-11	CARBON	4.7K	5%	1/4W
R934	1-249-421-11	CARBON	2.2K	5%	1/4W
R935	1-249-421-11	CARBON	2.2K	5%	1/4W
R936	1-249-421-11	CARBON	2.2K	5%	1/4W
R937	1-249-431-11	CARBON	15K	5%	1/4W
R938	1-249-437-11	CARBON	47K	5%	1/4W
R939	1-249-423-11	CARBON	3.3K	5%	1/4W
R940	1-249-437-11	CARBON	47K	5%	1/4W
R941	1-249-431-11	CARBON	15K	5%	1/4W
R942	1-249-437-11	CARBON	47K	5%	1/4W
R943	1-249-423-11	CARBON	3.3K	5%	1/4W
R944	1-249-437-11	CARBON	47K	5%	1/4W
R945	1-249-431-11	CARBON	15K	5%	1/4W
R946	1-249-437-11	CARBON	47K	5%	1/4W
R947	1-249-423-11	CARBON	3.3K	5%	1/4W
R948	1-249-437-11	CARBON	47K	5%	1/4W
R949	1-249-431-11	CARBON	15K	5%	1/4W
R950	1-249-437-11	CARBON	47K	5%	1/4W
R951	1-249-423-11	CARBON	3.3K	5%	1/4W
R952	1-249-437-11	CARBON	47K	5%	1/4W
R953	1-247-862-11	CARBON	20K	5%	1/4W
R954	1-249-441-11	CARBON	100K	5%	1/4W
R955	1-249-437-11	CARBON	47K	5%	1/4W
R957	1-249-433-11	CARBON	22K	5%	1/4W
R958	1-249-433-11	CARBON	22K	5%	1/4W
R959	1-249-433-11	CARBON	22K	5%	1/4W
R960	1-249-433-11	CARBON	22K	5%	1/4W
R961	1-249-433-11	CARBON	22K	5%	1/4W
R962	1-249-433-11	CARBON	22K	5%	1/4W
R963	1-249-433-11	CARBON	22K	5%	1/4W
R964	1-249-411-11	CARBON	330	5%	1/4W
R965	1-249-411-11	CARBON	330	5%	1/4W
R966	1-249-411-11	CARBON	330	5%	1/4W
R967	1-249-411-11	CARBON	330	5%	1/4W
R968	1-249-411-11	CARBON	330	5%	1/4W
R969	1-249-411-11	CARBON	330	5%	1/4W
R970	1-249-411-11	CARBON	330	5%	1/4W
R971	1-249-411-11	CARBON	330	5%	1/4W
R972	1-249-411-11	CARBON	330	5%	1/4W
R973	1-249-411-11	CARBON	330	5%	1/4W
R974	1-249-411-11	CARBON	330	5%	1/4W

Ref.No.	Part No.	Description
R975	1-249-411-11	CARBON 330 5% 1/4W
R976	1-249-411-11	CARBON 330 5% 1/4W
R977	1-249-411-11	CARBON 330 5% 1/4W
R978	1-249-417-11	CARBON 1K 5% 1/4W
R982	1-249-437-11	CARBON 47K 5% 1/4W
R983	1-249-437-11	CARBON 47K 5% 1/4W
R985	1-249-425-11	CARBON 4.7K 5% 1/4W
R986	1-249-425-11	CARBON 4.7K 5% 1/4W
RV603	1-226-772-11	RES. ADJ. METAL GLAZE 4.7K
RV604	1-226-772-11	RES. ADJ. METAL GLAZE 4.7K
RV703	1-226-772-11	RES. ADJ. METAL GLAZE 4.7K
RV704	1-226-772-11	RES. ADJ. METAL GLAZE 4.7K
RV702	1-226-774-11	RES. ADJ. METAL GLAZE 47K
RV901	1-230-566-11	RES. VAR, SLIDE 20K(SPEED CONTROL)
RV902	1-230-564-11	RES. VAR, SLIDE 10K(TONE)
RV903	1-230-564-11	RES. VAR, SLIDE 10K(VOLUME)
RY101	1-515-642-11	RELAY
RY201	1-515-642-11	RELAY
S101	1-552-334-00	SWITCH, BAND CHANGER (TAPE SPEED)
S601	1-570-503-11	SWITCH, MICRO (CASSETTE EMPTY DET, DECK-A)
S701	1-570-503-11	SWITCH, MICRO (CASSETTE EMPTY DET, DECK-B)
S901	1-554-118-00	SWITCH, PUSH (1 KEY){MONITOR A/B}
S902	1-570-550-11	SWITCH, PUSH (5 KEY){CHANNEL}
S903	1-554-118-00	SWITCH, PUSH (1 KEY) (MONITOR TAPE/SOURCE)
S904	1-571-083-21	SWITCH, SLIDE (PA)
S905	1-571-083-21	SWITCH, SLIDE (SPEED CONTROL)
S906	1-570-313-11	SWITCH, KEY BOARD (STOP-A)
S907	1-570-313-11	SWITCH, KEY BOARD (FF-A)
S908	1-570-313-11	SWITCH, KEY BOARD (PLAY-A)
S909	1-570-313-11	SWITCH, KEY BOARD (REW-A)
S910	1-570-313-11	SWITCH, KEY BOARD (REC-A)
S911	1-570-313-11	SWITCH, KEY BOARD (1)
S912	1-570-313-11	SWITCH, KEY BOARD (2)
S913	1-570-313-11	SWITCH, KEY BOARD (3)
S914	1-570-313-11	SWITCH, KEY BOARD (4)
S915	1-570-313-11	SWITCH, KEY BOARD (5)
S916	1-570-313-11	SWITCH, KEY BOARD (6)
S917	1-570-313-11	SWITCH, KEY BOARD (STOP-B)
S918	1-570-313-11	SWITCH, KEY BOARD (FF-B)
S919	1-570-313-11	SWITCH, KEY BOARD (PLAY-B)
S920	1-570-313-11	SWITCH, KEY BOARD (REW-B)
S921	1-570-313-11	SWITCH, KEY BOARD (REC-B)
S922	1-570-313-11	SWITCH, KEY BOARD (7)
S923	1-570-313-11	SWITCH, KEY BOARD (8)
S924	1-570-313-11	SWITCH, KEY BOARD (9)
S925	1-570-313-11	SWITCH, KEY BOARD (0)
S926	1-570-313-11	SWITCH, KEY BOARD (SEARCH)
S927	1-570-313-11	SWITCH, KEY BOARD (REC END)

Ref.No.	Part No.	Description
S928	1-570-313-11	SWITCH, KEY BOARD (RESET-A)
S929	1-570-313-11	SWITCH, KEY BOARD (DECK-A)
S930	1-552-334-00	SWITCH, BAND CHANGER (AUTO CHANGE)
S931	1-570-313-11	SWITCH, KEY BOARD (RESET-B)
S932	1-570-313-11	SWITCH, KEY BOARD (DECK-B)
S933	1-570-361-11	SWITCH, SLIDE (DIGITAL CORD) (REVERSE TIME)
S934	1-571-083-21	SWITCH, SLIDE (TRANSCRIBE)
S935	1-553-539-00	SWITCH, MICRO (STANDBY/ON)
SP901	1-503-344-21	SPEAKER
T901	△.1-449-478-11	TRANSFORMER, POWER
X901	1-567-160-21	OSCILLATOR, CERAMIC (4.19MHZ)

ACCESSORY & PACKING MATERIAL

- 3-315-007-02 KEY
- 3-345-444-01 CUSHION (LEFT)
- 3-345-445-01 CUSHION (RIGHT)
- 3-345-446-01 INDIVIDUAL CARTON
- 3-570-631-51 BAG, POLYETHYLENE
- 3-701-613-00 BAG, POLYETHYLENE
- 3-769-762-11 MANUAL INSTRUCTION
- 8-890-126-15 TAPE (DC-90N(S)E)

Note:
 The components identified by mark  or dotted line with mark  are critical for safety. Replace only with part number specified.

BM-246

SONY SERVICE MANUAL

AEP Model
UK Model

SUPPLEMENT-1

File this supplement with the service manual.

Subject: Change notice for audio circuit

(SPM-95014)

- Applicable Serial No.
AEP Model: 0502351 and after
UK Model: 0501299 and after

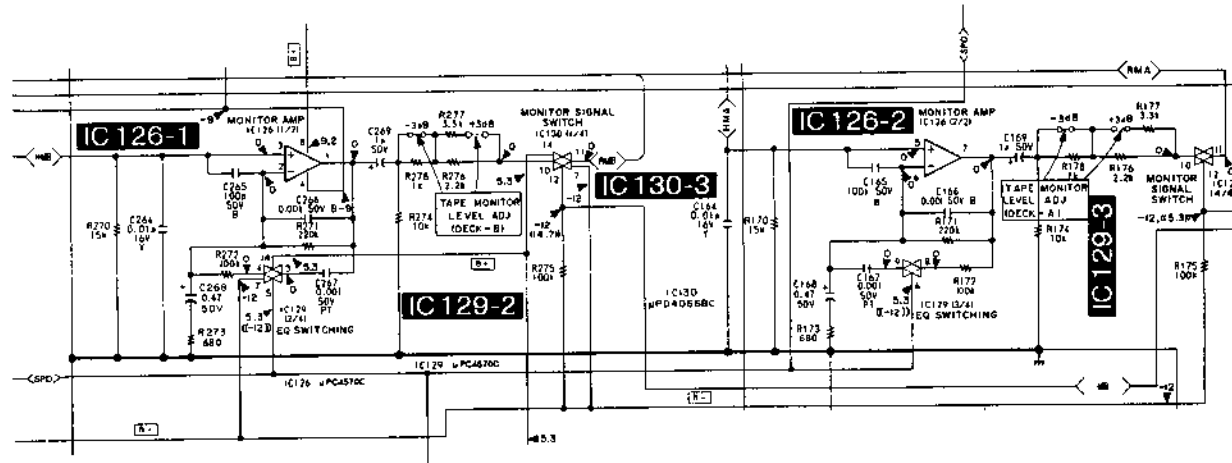

3. PRINTED WIRING BOARD (AUDIO BOARD)

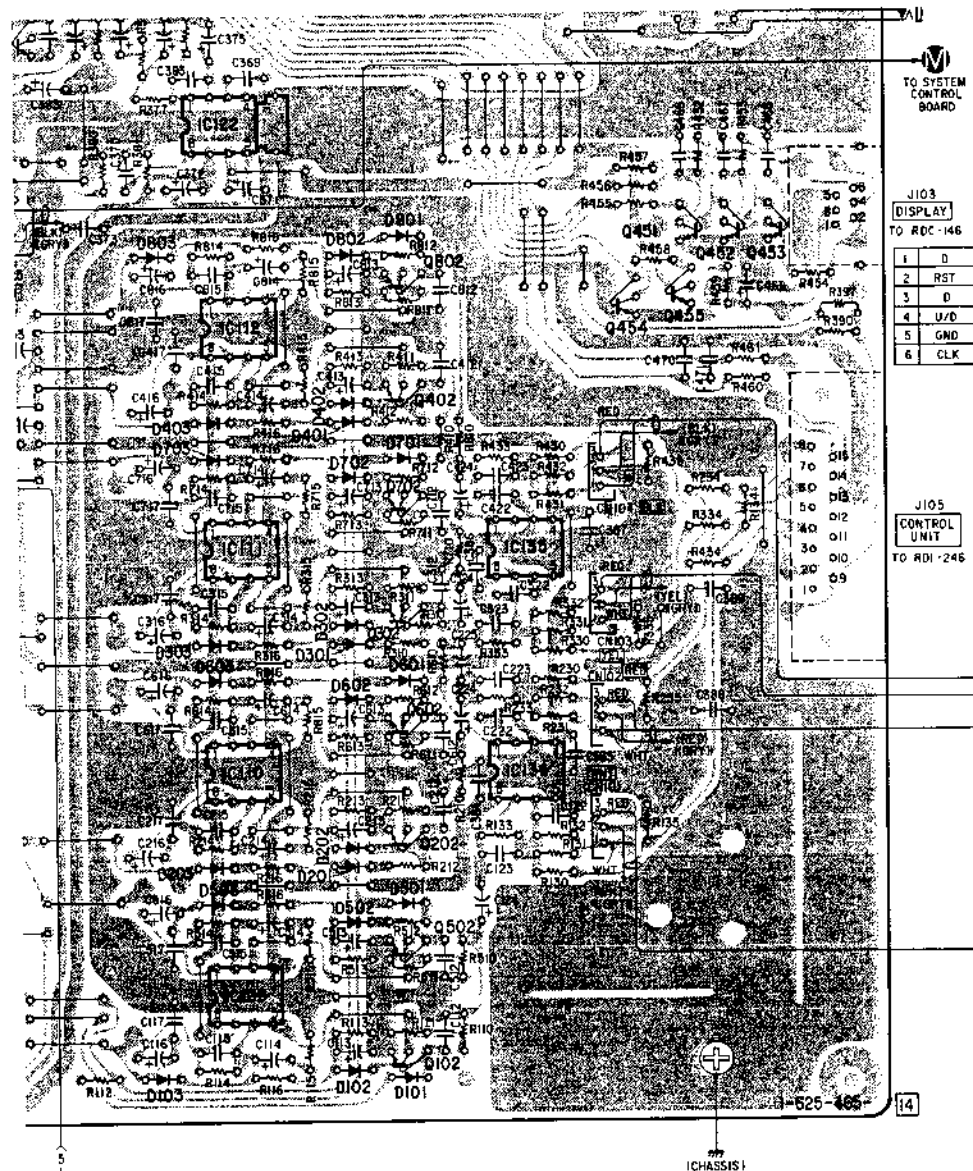

4. CHANGED PARTS

Ref. No.	Former Parts		New Parts		Remarks
	Description	Part No.	Description	Part No.	
C120	ELECT 10 μF 20% 50V	1-126-963-11	ELECT 4.7 μF 20% 50V	1-126-963-11	CHANGED
C124		1-126-301-11	ELECT 1 μF 20% 50V	1-126-301-11	ADDED
C166	CERAMIC 470PF 10% 50V	1-162-294-31	CERAMIC 0.001 μF 10% 50V	1-162-294-31	CHANGED
C167	MYLAR 0.0022 μF 5% 50V	1-162-294-31	CERAMIC 0.001 μF 10% 50V	1-162-294-31	CHANGED
C168	ELECT 1 μF 20% 50V	1-124-902-00	ELECT 0.47 μF 20% 50V	1-124-902-00	CHANGED
C220	ELECT 10 μF 20% 50V	1-126-963-11	ELECT 4.7 μF 20% 50V	1-126-963-11	CHANGED
C224		1-126-301-11	ELECT 1 μF 20% 50V	1-126-301-11	ADDED
C225		1-126-301-11	ELECT 1 μF 20% 50V	1-126-301-11	ADDED
C256	CERAMIC 470PF 10% 50V	1-162-294-31	CERAMIC 0.001 μF 10% 50V	1-162-294-31	CHANGED
C267	MYLAR 0.0022 μF 5% 50V	1-162-294-31	CERAMIC 0.001 μF 10% 50V	1-162-294-31	CHANGED
C268	ELECT 1 μF 20% 50V	1-124-902-00	ELECT 0.47 μF 20% 50V	1-124-902-00	CHANGED
C320	ELECT 10 μF 20% 50V	1-126-963-11	ELECT 4.7 μF 20% 50V	1-126-963-11	CHANGED
C324		1-126-301-11	ELECT 1 μF 20% 50V	1-126-301-11	ADDED
C420	ELECT 10 μF 20% 50V	1-126-963-11	ELECT 4.7 μF 20% 50V	1-126-963-11	CHANGED
C424		1-126-301-11	ELECT 1 μF 20% 50V	1-126-301-11	ADDED
C520	ELECT 10 μF 20% 50V	1-126-963-11	ELECT 4.7 μF 20% 50V	1-126-963-11	CHANGED
C620	ELECT 10 μF 20% 50V	1-126-963-11	ELECT 4.7 μF 20% 50V	1-126-963-11	CHANGED
C720	ELECT 10 μF 20% 50V	1-126-963-11	ELECT 4.7 μF 20% 50V	1-126-963-11	CHANGED
C820	ELECT 10 μF 20% 50V	1-126-963-11	ELECT 4.7 μF 20% 50V	1-126-963-11	CHANGED
IC101	IC NJM4560D-D	8-759-106-41	IC μPC4570C	8-759-106-41	CHANGED
IC102	IC NJM4560D-D	8-759-106-41	IC μPC4570C	8-759-106-41	CHANGED
IC103	IC NJM4560D-D	8-759-106-41	IC μPC4570C	8-759-106-41	CHANGED
IC104	IC NJM4560D-D	8-759-106-41	IC μPC4570C	8-759-106-41	CHANGED
IC124	IC NJM4560D-D	8-759-106-41	IC μPC4570C	8-759-106-41	CHANGED
IC126	IC NJM4560D-D	8-759-106-41	IC μPC4570C	8-759-106-41	CHANGED
IC134	IC NJM4560D-D	8-759-106-41	IC μPC4570C	8-759-106-41	CHANGED
IC135	IC NJM4560D-D	8-759-106-41	IC μPC4570C	8-759-106-41	CHANGED
R120	CARBON 4.7K 5% 1/4W	1-249-423-11	CARBON 3.3K 5% 1/4W	1-249-423-11	CHANGED
R121	CARBON 100K 5% 1/4W	1-247-887-00	CARBON 220K 5% 1/4W	1-247-887-00	CHANGED
R122	CARBON 1.5K 5% 1/4W	1-249-411-11	CARBON 330 5% 1/4W	1-249-411-11	CHANGED
R124	CARBON 1K 5% 1/4W	1-249-426-11	CARBON 5.6K 5% 1/4W	1-249-426-11	CHANGED
R125	CARBON 22K 5% 1/4W	1-249-441-11	CARBON 100K 5% 1/4W	1-249-441-11	CHANGED
R131	CARBON 3.3K 5% 1/4W	1-249-419-11	CARBON 1.5K 5% 1/4W	1-249-419-11	CHANGED
R132	CARBON 3.3K 5% 1/4W	1-249-419-11	CARBON 1.5K 5% 1/4W	1-249-419-11	CHANGED
R171	CARBON 100K 5% 1/4W	1-247-887-00	CARBON 220K 5% 1/4W	1-247-887-00	CHANGED
R172	CARBON 47K 5% 1/4W	1-249-441-11	CARBON 100K 5% 1/4W	1-249-441-11	CHANGED
R173	CARBON 1K 5% 1/4W	1-249-415-11	CARBON 680 5% 1/4W	1-249-415-11	CHANGED
R176	CARBON 1K 5% 1/4W	1-249-421-11	CARBON 2.2K 5% 1/4W	1-249-421-11	CHANGED
R177	CARBON 2.2K 5% 1/4W	1-249-423-11	CARBON 3.3K 5% 1/4W	1-249-423-11	CHANGED
R178	CARBON 470 5% 1/4W	1-249-417-11	CARBON 1K 5% 1/4W	1-249-417-11	CHANGED
R220	CARBON 4.7K 5% 1/4W	1-249-423-11	CARBON 3.3K 5% 1/4W	1-249-423-11	CHANGED
R221	CARBON 100K 5% 1/4W	1-247-887-00	CARBON 220K 5% 1/4W	1-247-887-00	CHANGED
R222	CARBON 1.5K 5% 1/4W	1-249-411-11	CARBON 330 5% 1/4W	1-249-411-11	CHANGED
R224	CARBON 1K 5% 1/4W	1-249-426-11	CARBON 5.6K 5% 1/4W	1-249-426-11	CHANGED
R225	CARBON 22K 5% 1/4W	1-249-441-11	CARBON 100K 5% 1/4W	1-249-441-11	CHANGED
R231	CARBON 3.3K 5% 1/4W	1-249-419-11	CARBON 1.5K 5% 1/4W	1-249-419-11	CHANGED
R232	CARBON 3.3K 5% 1/4W	1-249-419-11	CARBON 1.5K 5% 1/4W	1-249-419-11	CHANGED

Ref. No.	Former Parts		New Parts		Remarks
	Description	Part No.	Description	Part No.	
	<RESISTOR>		<RESISTOR>		
R271	CARBON 100K 5% 1/4W	1-247-887-00	CARBON 220K 5% 1/4W		CHANGED
R272	CARBON 47K 5% 1/4W	1-249-441-11	CARBON 100K 5% 1/4W		CHANGED
R273	CARBON 1K 5% 1/4W	1-249-415-11	CARBON 680 5% 1/4W		CHANGED
R276	CARBON 1K 5% 1/4W	1-249-421-11	CARBON 2.2K 5% 1/4W		CHANGED
R277	CARBON 2.2K 5% 1/4W	1-249-423-11	CARBON 3.3K 5% 1/4W		CHANGED
R278	CARBON 470 5% 1/4W	1-249-417-11	CARBON 1k 5% 1/4W		CHANGED
R320	CARBON 4.7K 5% 1/4W	1-249-423-11	CARBON 3.3K 5% 1/4W		CHANGED
R321	CARBON 100K 5% 1/4W	1-247-887-00	CARBON 220K 5% 1/4W		CHANGED
R322	CARBON 1.5K 5% 1/4W	1-249-411-11	CARBON 330 5% 1/4W		CHANGED
R324	CARBON 1K 5% 1/4W	1-249-426-11	CARBON 5.6K 5% 1/4W		CHANGED
R325	CARBON 22K 5% 1/4W	1-249-441-11	CARBON 100K 5% 1/4W		CHANGED
R331	CARBON 3.3K 5% 1/4W	1-249-419-11	CARBON 1.5K 5% 1/4W		CHANGED
R332	CARBON 3.3K 5% 1/4W	1-249-419-11	CARBON 1.5K 5% 1/4W		CHANGED
R420	CARBON 4.7K 5% 1/4W	1-249-423-11	CARBON 3.3K 5% 1/4W		CHANGED
R421	CARBON 100K 5% 1/4W	1-247-887-00	CARBON 220K 5% 1/4W		CHANGED
R422	CARBON 1.5K 5% 1/4W	1-249-411-11	CARBON 330 5% 1/4W		CHANGED
R424	CARBON 1K 5% 1/4W	1-249-426-11	CARBON 5.6K 5% 1/4W		CHANGED
R425	CARBON 22K 5% 1/4W	1-249-441-11	CARBON 100K 5% 1/4W		CHANGED
R431	CARBON 3.3K 5% 1/4W	1-249-419-11	CARBON 1.5K 5% 1/4W		CHANGED
R432	CARBON 3.3K 5% 1/4W	1-249-419-11	CARBON 1.5K 5% 1/4W		CHANGED
R520	CARBON 4.7K 5% 1/4W	1-249-423-11	CARBON 3.3K 5% 1/4W		CHANGED
R521	CARBON 100K 5% 1/4W	1-247-887-00	CARBON 220K 5% 1/4W		CHANGED
R522	CARBON 1.5K 5% 1/4W	1-249-411-11	CARBON 330 5% 1/4W		CHANGED
R524	CARBON 1K 5% 1/4W	1-249-426-11	CARBON 5.6K 5% 1/4W		CHANGED
R525	CARBON 22K 5% 1/4W	1-249-441-11	CARBON 100K 5% 1/4W		CHANGED
R620	CARBON 4.7K 5% 1/4W	1-249-423-11	CARBON 3.3K 5% 1/4W		CHANGED
R621	CARBON 100K 5% 1/4W	1-247-887-00	CARBON 220K 5% 1/4W		CHANGED
R622	CARBON 1.5K 5% 1/4W	1-249-411-11	CARBON 330 5% 1/4W		CHANGED
R624	CARBON 1K 5% 1/4W	1-249-426-11	CARBON 5.6K 5% 1/4W		CHANGED
R625	CARBON 22K 5% 1/4W	1-249-441-11	CARBON 100K 5% 1/4W		CHANGED
R720	CARBON 4.7K 5% 1/4W	1-249-423-11	CARBON 3.3K 5% 1/4W		CHANGED
R721	CARBON 100K 5% 1/4W	1-247-887-00	CARBON 220K 5% 1/4W		CHANGED
R722	CARBON 1.5K 5% 1/4W	1-249-411-11	CARBON 330 5% 1/4W		CHANGED
R724	CARBON 1K 5% 1/4W	1-249-426-11	CARBON 5.6K 5% 1/4W		CHANGED
R725	CARBON 22K 5% 1/4W	1-249-441-11	CARBON 100K 5% 1/4W		CHANGED
R820	CARBON 4.7K 5% 1/4W	1-249-423-11	CARBON 3.3K 5% 1/4W		CHANGED
R821	CARBON 100K 5% 1/4W	1-247-887-00	CARBON 220K 5% 1/4W		CHANGED
R822	CARBON 1.5K 5% 1/4W	1-249-411-11	CARBON 330 5% 1/4W		CHANGED
R824	CARBON 1K 5% 1/4W	1-249-426-11	CARBON 5.6K 5% 1/4W		CHANGED
R825	CARBON 22K 5% 1/4W	1-249-441-11	CARBON 100K 5% 1/4W		CHANGED