

BM-87DST

SERVICE MANUAL

Ver 1.1 2003.06

US Model
Australian Model



Model Name Using Similar Mechanism	NEW
Tape Transport Mechanism Type	MB-87-59

SPECIFICATIONS

Recording system	4-track 2-channel monaural (L channel for electronic index signals, R channel for sound signals)
Tape speed	4.8 cm/s or 2.4 cm/s
Fast winding time	Approx. 2 min. 20 sec. with Sony Cassette DC-90
Frequency response	200 – 8,000 Hz (4.8 cm/s) 200 – 5,000 Hz (2.4 cm/s)
Speaker	Approx. 5.7 cm (2 ¼ in.) dia.
Power output	350 mW (at 10% distortion)
Input	TELEPHONE PICKUP (minijack) Sensitivity 0.2 mV Input impedance 10 kilohms
Output	Ⓜ (headphones) jack (stereo minijack) for 8-300 ohms headphones Approx. 47-ohm
CONTROL UNIT connector	For HAND control unit or FOOT control unit Variable range of the tape speed From approx. -20% to +50%
Power requirements	9 V DC AC power adaptor 120 V AC, 60 Hz
Power consumption	14 W (with the supplied AC power adaptor)
Dimensions	Approx. 200 × 70 × 245 mm (w×h×d) (7 7/8 × 2 7/8 × 9 3/4 in.) including projecting parts and controls
Mass	Approx. 1.2 kg (2 lb. 11 oz.)
Supplied accessory	AC power adaptor (1) Foot control unit (1) Stereo Headphones (1)

Design and specifications are subject to change without notice.

The BM-87DST cannot be used with the Microcassette adaptor MA-50.

DICTATOR/ TRANSCRIBER

9-927-638-12
2003F02-1
© 2003.06

Sony Corporation
Personal Audio Company
Published by Sony Engineering Corporation

SONY®

SECTION 1 SERVICING NOTE

TABLE OF CONTENTS

Specifications	1
1. SERVICING NOTE	2
2. GENERAL	
Features	3
Precautions	3
Operation Flow Chart	4
Location and Function of Controls	5
Preparation	6
Dictating	7
Transcribing	9
Erasing	11
Alarm System	12
Telephone Recording	12
3. DISASSEMBLY	
3-1. Cabinet (Rear) Assy , Cabinet (Front) ASSY	13
3-2. Main Board, Connector (12P) Board	13
3-3. LED Board	14
3-4. Mechanism Deck	14
3-5. Servo Board, "Head Magnetic (REC/PB/Erase) (HRP901)", Motor (F/R) ASSY (M902)	15
3-6. Belt (FWD), Belt (F/R)	15
3-7. Motor (FWD) ASSY(M901)	16
4. MECHANICAL ADJUSTMENTS	17
5. ELECTRICAL ADJUSTMENTS	18
6. DIAGRAMS	
6-1. Explanation of IC Terminals	19
6-2. Block Diagram	21
6-3. Printed Wiring Boards (Servo Section)	23
6-4. Schematic Diagram (Servo Section)	25
6-5. Printed Wiring Boards (Main Section)	28
6-6. Schematic Diagram (Main Section)	31
7. EXPLODED VIEWS	
7-1. Cabinet Section	35
7-2. Mechanism Deck Section (1) (MB-87-59)	36
7-3. Mechanism Deck Section (2) (MB-87-59)	37
8. ELECTRICAL PARTS LIST	38

NOTES FOR REPAIRING

1. **POWER (S101) Switch**
The POWER switch is not for turning ON/OFF the power source. Pay attention when repairing even the POWER switch is turned off.
 - The states when turning off the POWER switch are as follows.
 - a. Motors (M901, 902) will be stopped.
 - b. Plungers (PM901 to 903) will be turned off.
 - c. Amplifier output will be cut-off by muting on.
 The above items from "a" to "c" are controlled by the microcomputer which makes the pin 38 of IC109 (microcomputer) become Low level.
2. **Be careful the short circuit when repairing since the power supply circuit does not have any protection devices.**
Please note that the current shut down (D108) will be work when the power connected to the opposite way.
3. **Crack of Flywheel Gear and Cam Gear**
Do not turn the Flywheel counterclockwise.
The flywheel gear and cam gear may be crack when turn the flywheel counterclockwise.

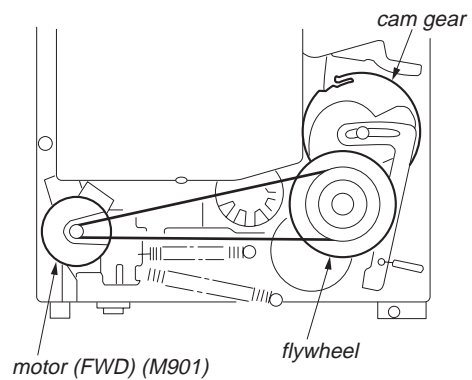

SAFETY-RELATED COMPONENT WARNING!!

COMPONENTS IDENTIFIED BY MARK \triangle OR DOTTED LINE WITH MARK \triangle ON THE SCHEMATIC DIAGRAMS AND IN THE PARTS LIST ARE CRITICAL TO SAFE OPERATION. REPLACE THESE COMPONENTS WITH SONY PARTS WHOSE PART NUMBERS APPEAR AS SHOWN IN THIS MANUAL OR IN SUPPLEMENTS PUBLISHED BY SONY.

Notes on chip component replacement

- Never reuse a disconnected chip component.
- Notice that the minus side of a tantalum capacitor may be damaged by heat.

Features

The Sony BM-87DST dictator/transcriber is designed to be used for both dictating and transcribing.

As a dictator

- The Sony HU-80 hand control unit (not supplied) remotely controls the BM-87DST dictator/transcriber.
- Electronic index signal — "LTK" (letter-end of document) signal — can be recorded on a tape while the unit is set in the recording (dictating), telephone recording, stop or playback mode.
- Alarm sound informs a recording error.
- Recording of telephone calls can be performed with the use of the optional telephonic recording adaptor.
- With the use of the supplied headphones, you can monitor the sound with the desired sound level during recording.

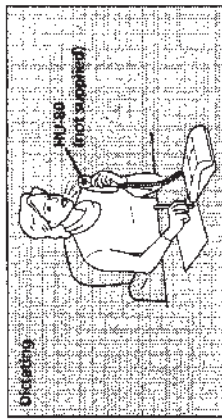

As a transcriber

- Auto stop function quickly accesses the dictated material.
- Auto backspace function with the REVERSE TIME control makes transcribing easy by enabling the reviewing of the last recorded words each time the playback is resumed.
- Rapid erasing function with the ● ERASE button and the ◀ REW button.

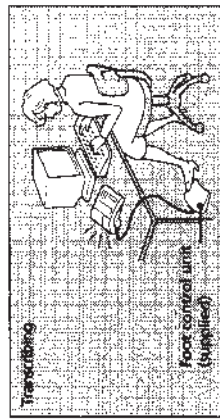

Precautions

- Operate the unit only on 9 V DC. For the AC operation, use the AC power adaptor supplied with the unit. Do not use any other AC power adaptor as it may cause a malfunction of the unit.
- Unplug the AC power adaptor from the wall outlet when it will not be used for an extended period of time. To disconnect the adaptor, pull it out by grasping the adaptor itself. Never pull it by the cord.
- Do not place the unit in a location near heat sources such as radiators or air ducts or in a place subject to direct sunlight, excessive dust, mechanical vibration or shock.
- Allow adequate air circulation to prevent an internal heat build-up. Do not place the unit near materials (curtains, draperies, etc.) that may block the ventilation holes.
- Should any solid object or liquid fall into the unit, unplug the unit and have it checked by qualified personnel before operating it any further.
- The supplied AC power adaptor becomes hot if it is connected to a wall outlet for a long period of time. However, this will not cause any mechanical problems.

If you have any questions or problems concerning your unit that are not covered in this manual, please consult the Sony dealer from whom you purchased the unit.

SECTION 2 GENERAL

This section is extracted from instruction manual.

Operation Flow Chart

For details, refer to the pages in ●.
 [] : Necessary step
 [] : Optional step

Dictating ●

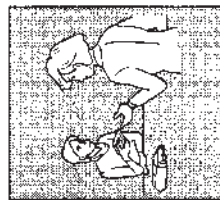
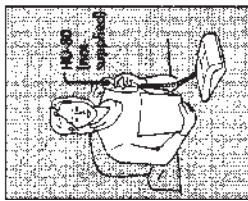
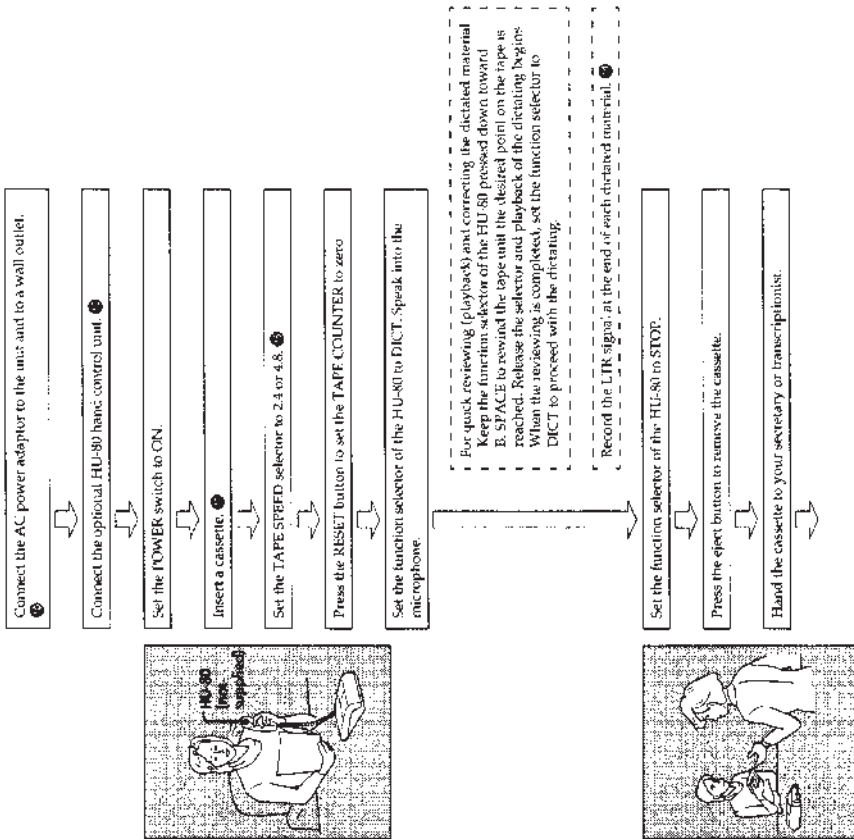

Transcribing ●

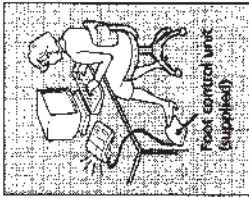
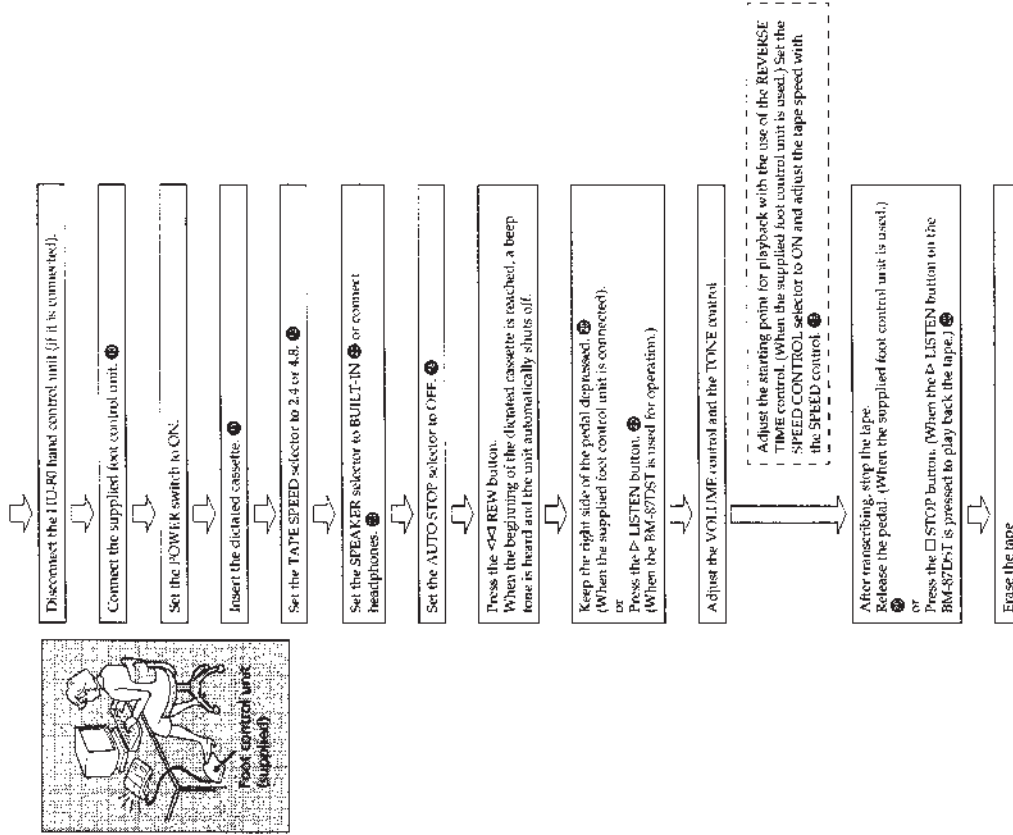

Location and Function of Controls

For details, refer to the pages indicated in ●.

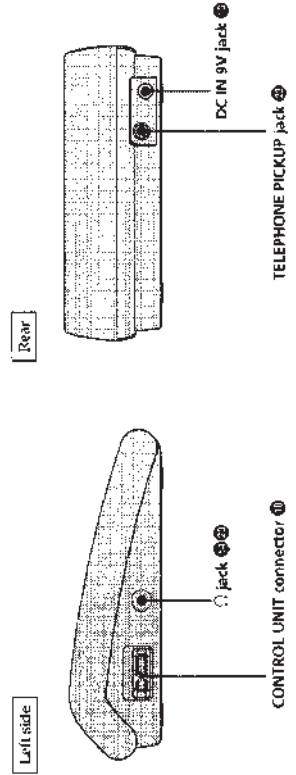
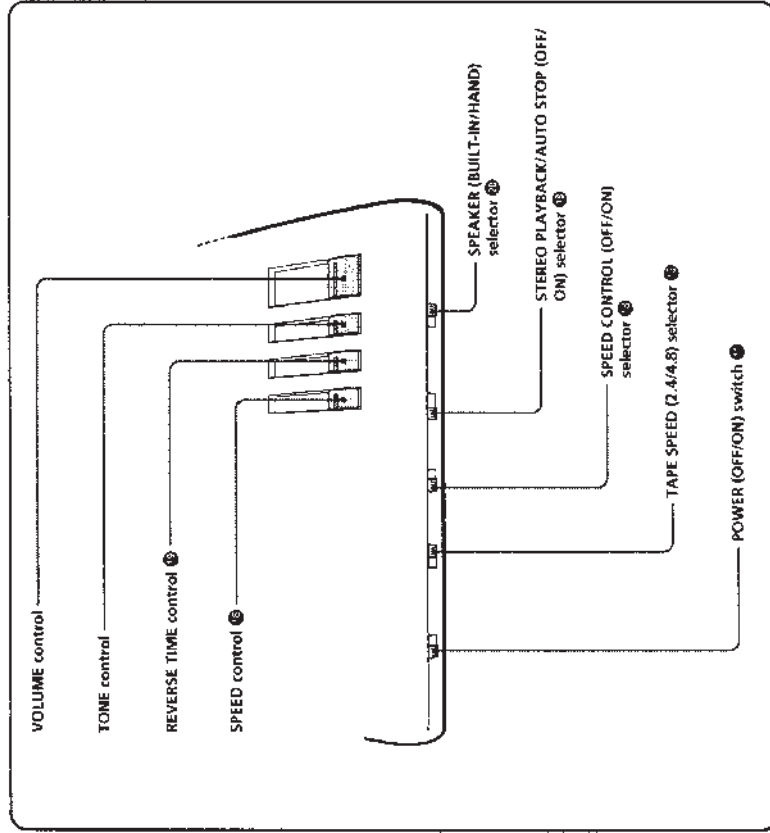
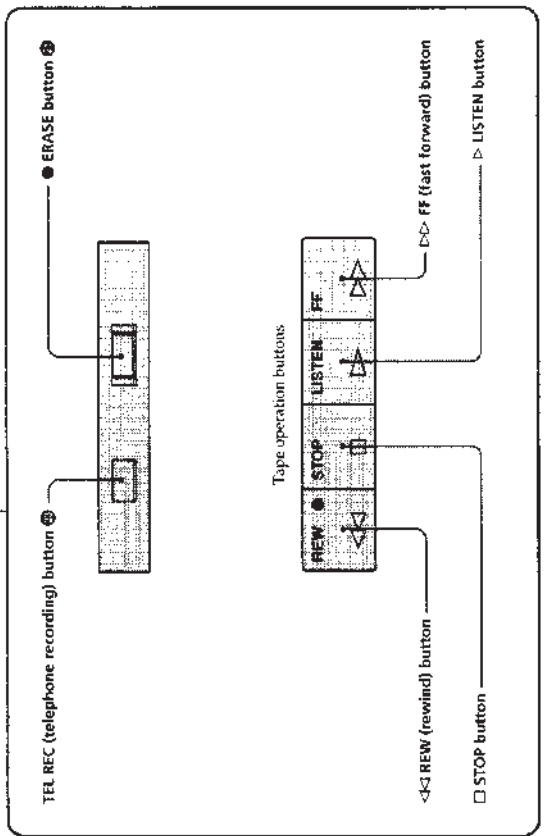
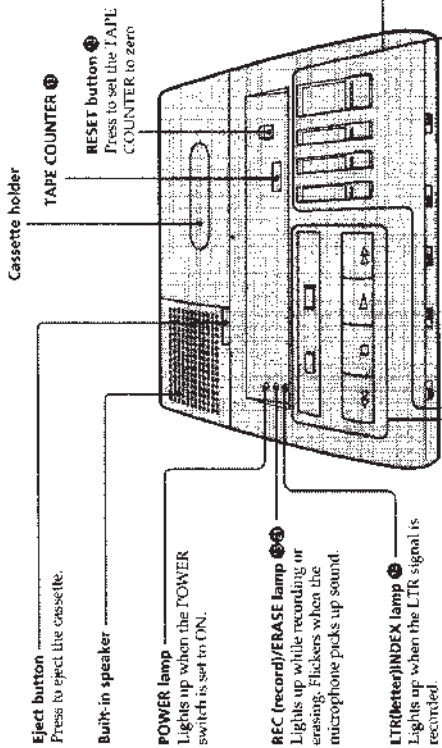

Preparation

Connecting the Power Source

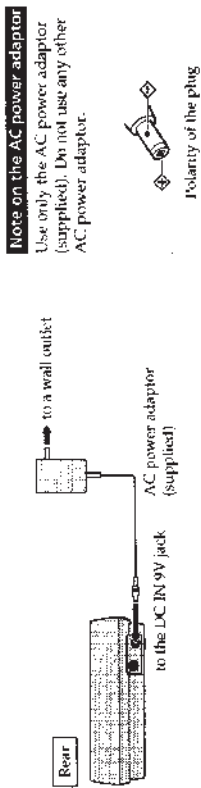

Connecting the HU-80 Hand Control Unit (not supplied)

For operation, refer to "Dictating" on page 13.

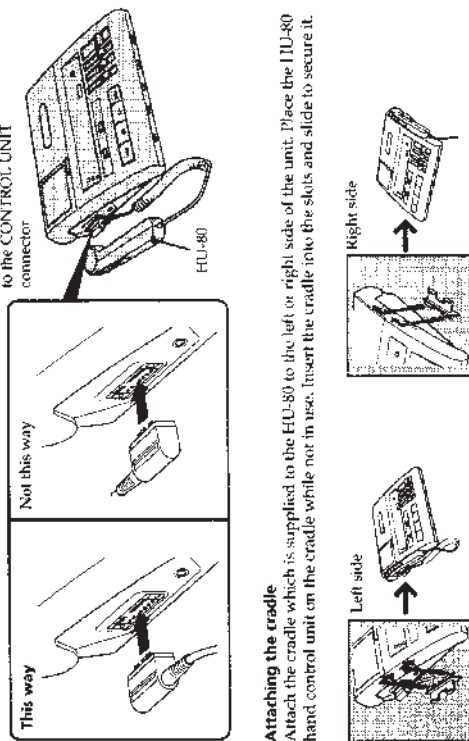

Connecting the Supplied Foot Control Unit.

For operation, refer to "Transcribing" on page 17.

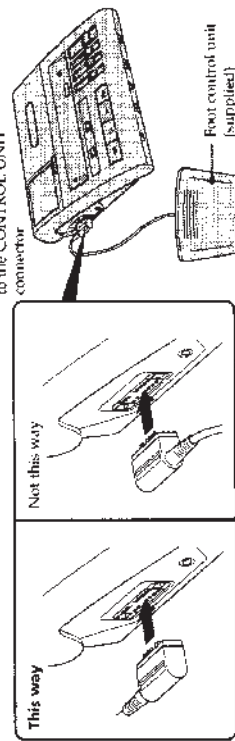

Inserting a Cassette

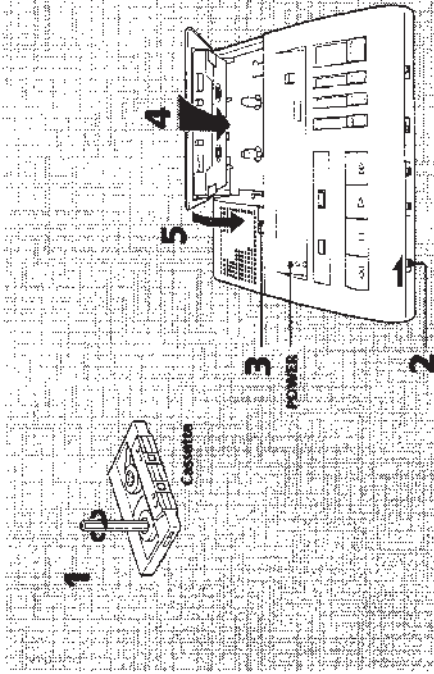

- 1 Take up any slack in the tape.
- 2 Set the **POWER** switch to **ON**.
The **POWER** lamp lights up.
- 3 Press the **eject** button to open the cassette holder.
- 4 Insert a cassette into the cassette holder with the side to be recorded or played back facing upward.
- 5 Close the cassette holder.

Preparation

■ Notes on cassettes

- Any standard cassette can be used, but the optional Sony leatherless cassette DC-60 or DC-90 is recommended. The use of a TYPE II (High Pleat) or TYPE IV (metal) cassette is not advisable.
- Choose a cassette of suitable length. The recording time on each side of these cassettes is as follows:
Sony DC-60 approx. 30 minutes (4.8 cm/s)
Sony DC-90 approx. 45 minutes (total time) are not advisable.
- The use of cassettes whose running time is longer than 90 minutes (total time) are not advisable.
- The letter A on the Sony cassette is embossed to help you distinguish that side of the cassette in a dimly lit area.

To prevent accidental erasure

When the unit is operated in the recording mode, any previous recordings will be automatically erased. For this reason, cassettes incorporate a safety device to prevent any accidental erasure. When the small tabs at the rear of a cassette are broken off, an interlock on the unit will be activated, preventing recording.*

To protect the recording on side A, break off the tab of that side.
To protect the recording on side B, break off the tab of that side.

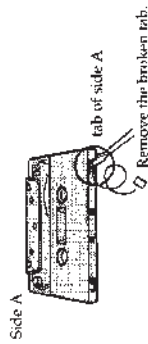

To reuse a cassette for recording after the tabs have been removed, simply cover each slot with a small piece of plastic tape. Do not stick any material on any other part of the cassette except the circled part, as illustrated below.

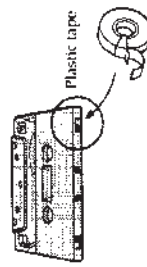

- When the cassette is loaded for telephone recording, with the tabs broken off and the TEL REC button is pressed, the beep tone is heard and the TEL REC button does not operate. When the cassette is loaded for dictating with the tabs broken off and the function selector is set to DICT, recording cannot be made and the beep tone is heard.

Dictating

To use the unit as a dictating machine, connect the HU-80 hand control unit (not supplied). For the connection instructions, see page 10.

Operation

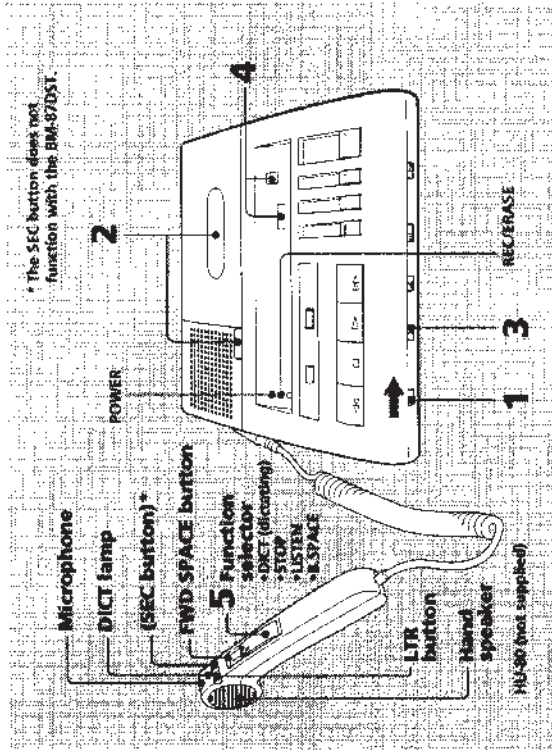

- 1 Set the POWER switch to ON.**
The POWER lamp lights up.
- 2 Insert a cassette.** (See page 11.)
- 3 Set the TAPE SPEED selector to 2.4 (cm/s) or 4.8 (cm/s).** (See page 15.)
- 4 Press the RESET button to set the TAPE COUNTER to zero.**
- 5 Set the function selector to DICT.**
Recording starts. Speak into the microphone.
The DICT lamp (HU-80) lights up and REC/ERASE lamp (BM-87DST) flickers when the microphone picks up the sound.

To stop the tape
Set the function selector to STOP.

Note

Keep the HU-80 away from the BM-87DST during recording. If not, noise may be recorded.

Useful Functions

■ LTR (letter) signal

You can record electronic index signals on the tape with the HL-80 while the unit is set in the recording (dictating), telephone recording, stop or playback mode.

LTR (letter-end of document) signal: Record at the end of each dictated material.

When the Auto stop function (page 18) is activated (AUTO STOP ON), the tape automatically stops at each index signal when it is rewound or fast forwarded. Dictated material can be located without the user's having to listen to the entire tape.

To record the LTR signal

Press the LTR button on the HL-80. Each time the button is pressed, the LTR INDEX lamp (BM-87DS1) lights up for about 3 seconds.

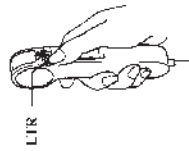

■ Notes

- The LTR signal should be recorded with the intervals of more than 6 seconds.
- Playback sound is muted while the LTR signal is recorded. However, the recorded material will be protected.
- While the LTR signal is being recorded with the SPEED CONTROL selector set to CN, the tape will run at the normal tape speed.

■ Monitoring while dictating

The recording can be monitored through the headphones. Connect the supplied stereo headphones to the ϕ jack located on the left side of the unit. You can hear the sound in stereo through the stereo headphones. The sound is monaural through the built-in speaker. Adjust the VOLUME monitor if necessary.

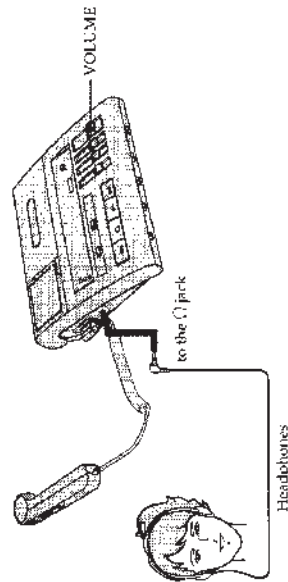

■ Quick reviewing (playback) and correcting the dictated material

You can easily play back the dictated material and correct it if necessary.

- 1 Keep the function selector of the HL-80 pressed down toward BSPACE to rewind the tape.
- 2 Release the selector. Playback of the dictating begins.
- 3 When the reviewing is completed, set the function selector to DICT to proceed with the dictating.

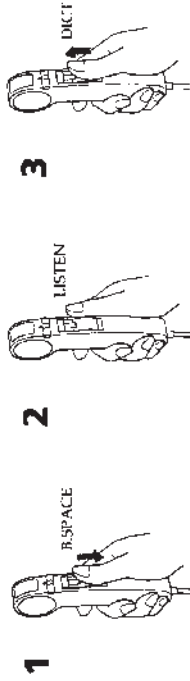

To fast forward the tape, keep the FWDSPACE button of the HL-80 pressed until the desired section is located.

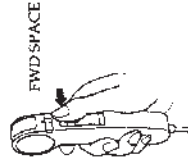

■ Tape speed selector

With the TAPE SPEED selector, you can change the length of recording time on a cassette. When the TAPE SPEED selector is set to 4.8 (centimeters/second), you can record the normal length on a cassette. (i.e. 60 minutes using both sides of a 60-minute cassette.)

When the TAPE SPEED selector is set to 2.4 (centimeters/second), you can record double the normal length on a cassette. (i.e. 120 minutes using both sides of a 60-minute cassette.)

■ Note

Tapes recorded in the TAPE SPEED 2.4 position cannot be played properly by a tape recorder without the TAPE SPEED selector function.

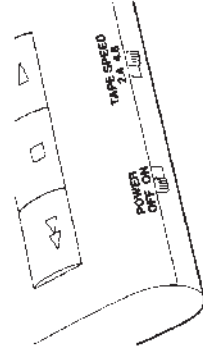

Tips for a More Efficient Dictating

Before you start dictating

- Organize your thoughts.
- Make notes or an outline of what you want to dictate.
- Check that the cassette is erased. (See page 21.)

When you start dictating

- Identify yourself. (Name, department, phone number, etc.)
- Indicate the type of dictating. (Memo, letter, etc.)
- Give transcribing instructions. (Type of stationery, number of copies, envelopes, etc.)
- Specify distribution. (Name, addresses, etc.)

During dictating

- Relax and speak clearly, at normal speed.
- Short sentences are best.
- Include punctuation.
- Spell difficult or unusual words.
- Correct your mistakes. (Review and redictate.) (See page 15.)
- At the end of each dictated material, record an LTR signal.

To use the unit as a transcribing machine, connect the supplied foot control unit. For the connection instructions, see page 10.

Operation

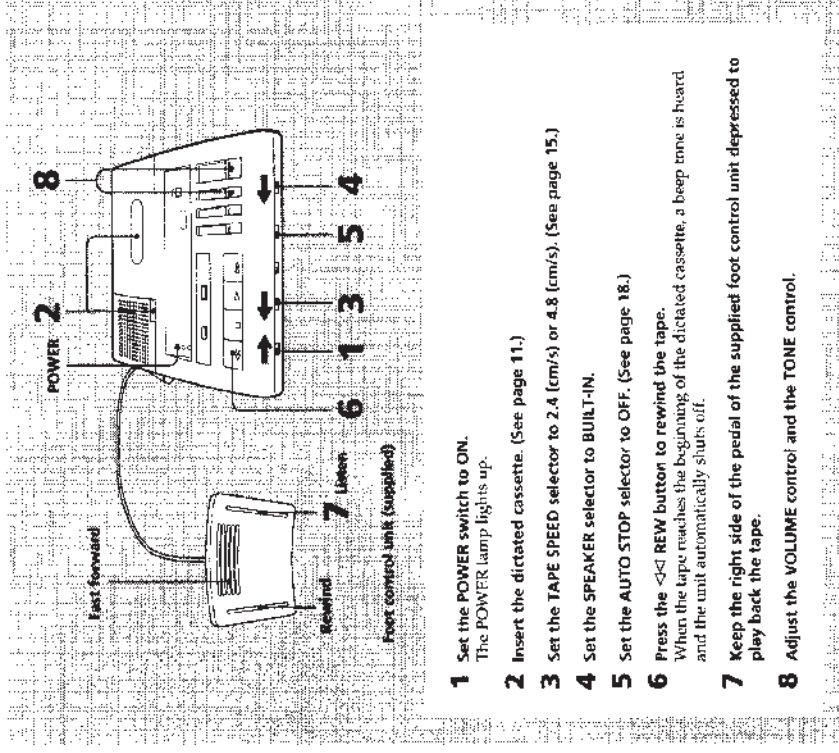

- 1 Set the POWER switch to ON.**
The POWER lamp lights up.
- 2 Insert the dictated cassette.** (See page 11.)
- 3 Set the TAPE SPEED selector to 2.4 (cm/s) or 4.8 (cm/s).** (See page 15.)
- 4 Set the SPEAKER selector to BUILT-IN.**
- 5 Set the AUTO STOP selector to OFF.** (See page 18.)
- 6 Press the << REW button to rewind the tape.**
When the tape reaches the beginning of the dictated cassette, a beep tone is heard and the unit automatically shuts off.
- 7 Keep the right side of the pedal of the supplied foot control unit depressed to play back the tape.**
- 8 Adjust the VOLUME control and the TONE control.**

To stop the tape
Release the pedal of the supplied foot control unit.

To rewind the tape
Keep the left side of the pedal of the supplied foot control unit depressed.

To fast forward the tape
Keep the center top of the pedal of the supplied foot control unit depressed.

Useful Functions

■ Auto stop function

With the Auto stop function, recorded documents can be located without the user's having to listen to the entire tape. This function activates only in the rewind or fast forward mode.

When the **AUTO STOP selector is set to ON**, the tape automatically stops at each LTR signal previously recorded on the tape. (See "LTR signal" on page 14.)

■ Notes

- The tape does not stop at the LTR signal even if the **AUTO STOP selector is set to ON** while the **▶▶** FF button or the **◀◀** REW button is continuously depressed.
- When the **AUTO STOP selector is set to ON**, the tape automatically stops at each SEC signal previously recorded on the tape with the Sony Professional Dictation Machine.

When the **AUTO STOP selector is set to OFF**, the tape does not stop even if the electronic index signals have been previously recorded.

■ Notes

- **E-INDEX** signal of the Sony conventional models corresponds to the LTR signal of BM-87DST.
- LTR signal and **E-INDEX** signal do not correspond to the cue signals used for the consumer type tape recorder.
- Set the **AUTO STOP selector to OFF** to transcribe either a music cassette or a cassette which has not been recorded with the Sony Professional Dictation Machine; otherwise the tape may automatically stop in the rewind or fast forward mode.

■ Controlling the speed

Set the **SPEED CONTROL selector to ON** to adjust the tape speed with the **SPEED** control. The tape can be played back at a speed faster or slower than normal. Set the **SPEED-CONTROL selector to OFF** to transcribe the dictated material at the normal speed.

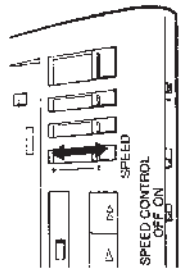

■ Auto backspace function

This function operates only when the supplied foot control unit is connected. With the use of the **REVERSE TIME** control, the tape is rewound a little each time it is stopped. Then, the last few reworded words can be reviewed when you resume playback. Adjust the **REVERSE TIME** control to determine the length of the tape to be rewound. At "9" position, the tape is rewound so that the dictated material can be reviewed for approximately 5 seconds*. At "0" position, the tape stops without being rewound at all.

- * Measured at some point near the middle of the tape. The reverse time will vary in accordance with the remaining length of the tape.

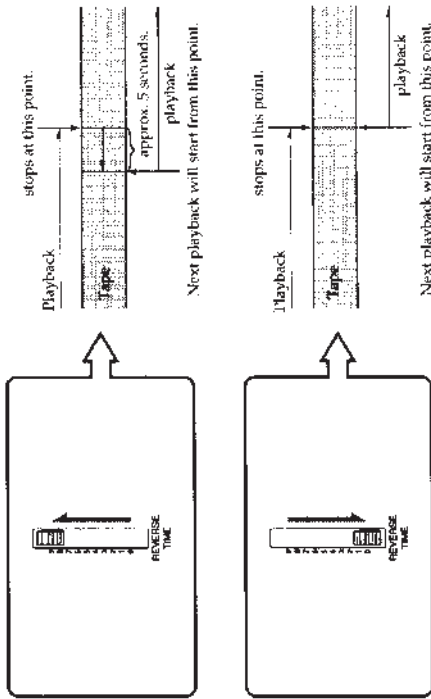

Set the **REVERSE TIME** control to the desired position and keep the right side of the pedal of the supplied foot control unit depressed to play back the tape.

■ Note

The reverse time will be different by a few seconds according to the remaining length or the total time of the tape.

■ Tape transport operation

	BM-8795ST	HU-80	Supplied foot control unit
Rewind	Press the << REW button.	Keep the function selector pressed down forward B. SPACE.	Keep the left side of the pedal depressed.
Stop	Press the □ STOP button.	Set the function selector to STOP.	Release the pedal.
Listen	Press the ▷ LISTEN button.	Set the function selector to LISTEN.	Keep the right side of the pedal depressed.
Fast Forward	Press the ▷▷ FF button.	Keep the FWD SPACE button pressed.	Keep the top center of the pedal depressed.

■ Private listening

Connect the supplied stereo headphones to the C jack. The sound will be heard through the stereo headphones and the speaker will be disconnected.

■ Selecting the speaker

You can play back the dictated material through the built-in speaker or the speaker on the HU-80 by setting the SPEAKER selector to BUILT-IN or HAND.



Tips on Transcribing

- Before typing, check the number of the dictated material and review the contents using the auto stop function.
- Erase the tape when transcribing is finished.

The recording can be erased as follows.

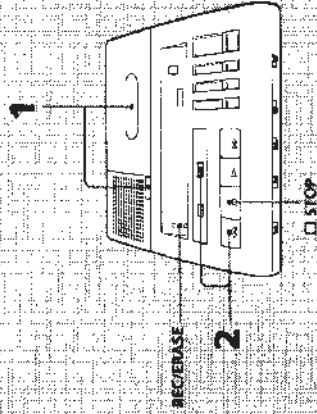



- 1** Insert the cassette with the side to be erased facing upward. Be sure not to rewind the tape after transcribing. The end section of the dictated material to be erased should be positioned at the recording head.
- 2** Keep the ● ERASE button pressed and then press the << REW button. The REC/ERASE lamp lights up. The section of the tape being rewound is erased.

To stop the tape
Press the □ STOP button.

Alarm System

The alarm system is activated in the following situations.

Alarm system	Situation	To release alarm system
When you press a button, 	<ul style="list-style-type: none"> No cassette is inserted The cassette's safety tabs have been removed. 	<p>First, release the button, then:</p> <ul style="list-style-type: none"> Insert a cassette. Insert a new cassette or cover the slot.
When the unit shuts off,  (about 2 seconds)	<ul style="list-style-type: none"> The end of the tape has been reached. The tape is torn. 	<p>Rewind the tape.</p> <p>Insert a new cassette.</p>
When the unit shuts off,  (about 0.5 second)	The LTR signal is detected while the tape is wound rapidly (in the fast forward or rewind mode) when the AUTO STOP selector is set to ON.	The beep tone stops after about 0.5 second.

Telephone Recording

To record a telephone conversation, connect the telephone recording adaptor (not supplied) to the TELEPHONE PICKUP jack. For further details, refer to the instruction manual of the telephone recording adaptor.

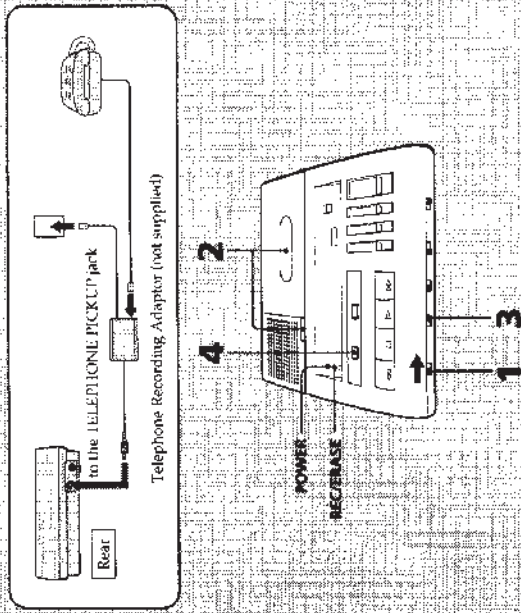

- 1 Set the POWER switch to ON.**
The POWER lamp lights up.
- 2 Insert a cassette.** (See page 11.)
- 3 Set the TAPE SPEED selector to 2.4 (cm/s) or 4.8 (cm/s).** (See page 15.)
- 4 Keep the TEL REC button pressed for more than a second.**
Telephone recording begins. The REC/ERASE lamp flickers when the telephone recording adaptor picks up the sound.

To stop the tape
Press the STOP button.

At the beginning of telephone recording

The LTR signal is automatically recorded. While the LTR signal is being recorded (for about 3 seconds), the unit cannot be stopped even though the STOP button is pressed.

During telephone recording

Only the LTR button (BU-88) and the STOP button (BM-87JST) are operative.

SECTION 3 DISASSEMBLY

●The equipment can be removed using the following procedure.

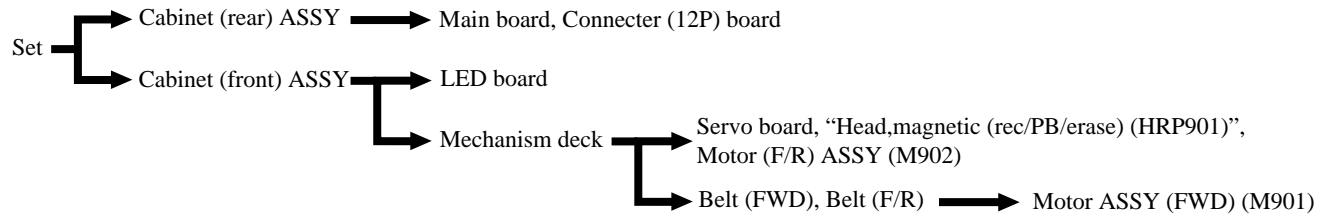

Note Follow the disassembly procedure in the numerical order given.

3-1. CABINET (REAR) ASSY, CABINET (FRONT) ASSY

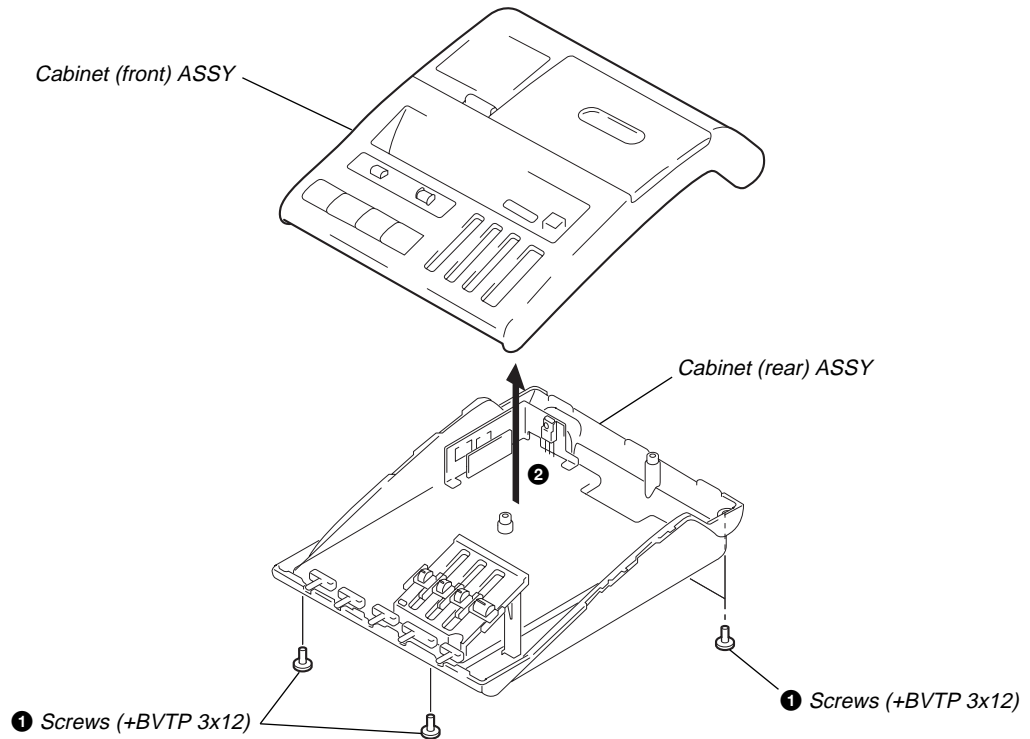

3-2. MAIN BOARD, CONNECTOR (12P) BOARD

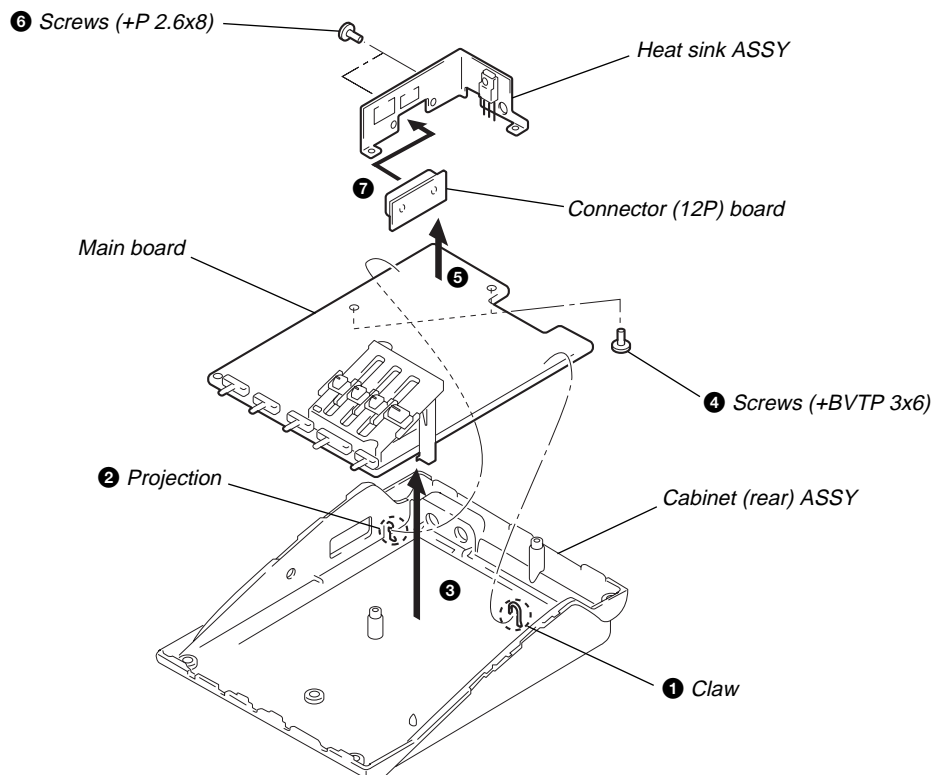

3-3. LED BOARD

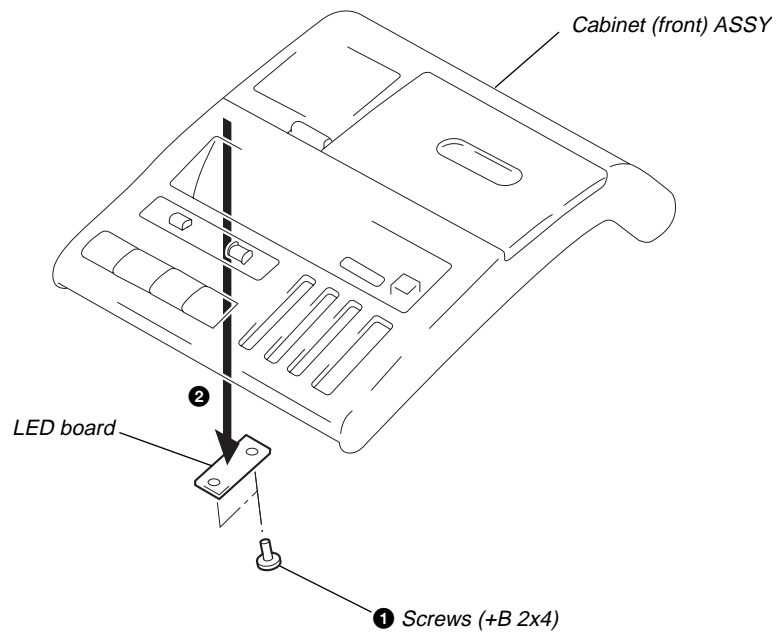

3-4. MECHANISM DECK

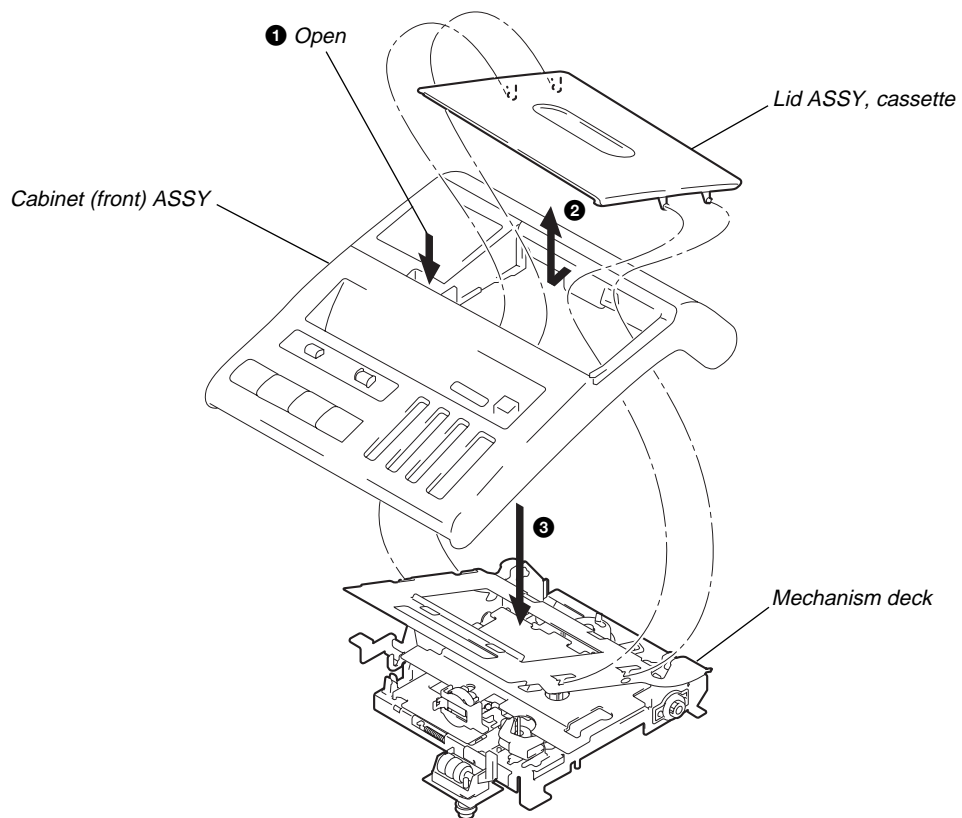

3-5. SERVO BOARD, "HEAD, MAGNETIC (REC / PB / ERASE) (HRP901)", MOTOR (F/R) ASSY (M902)

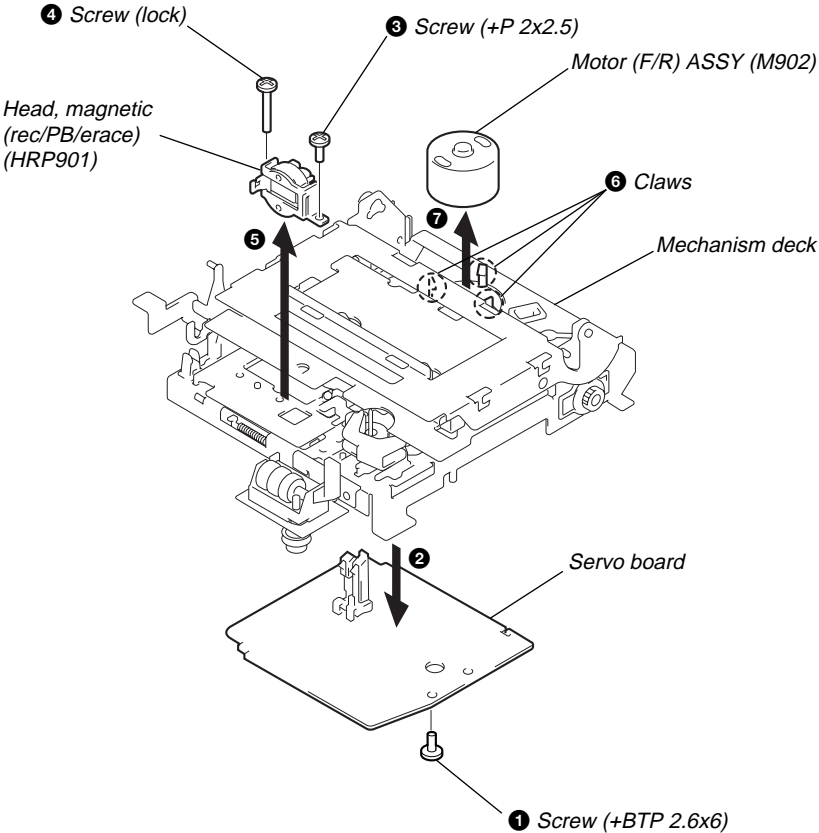

3-6. BELT (FWD), BELT (F/R)

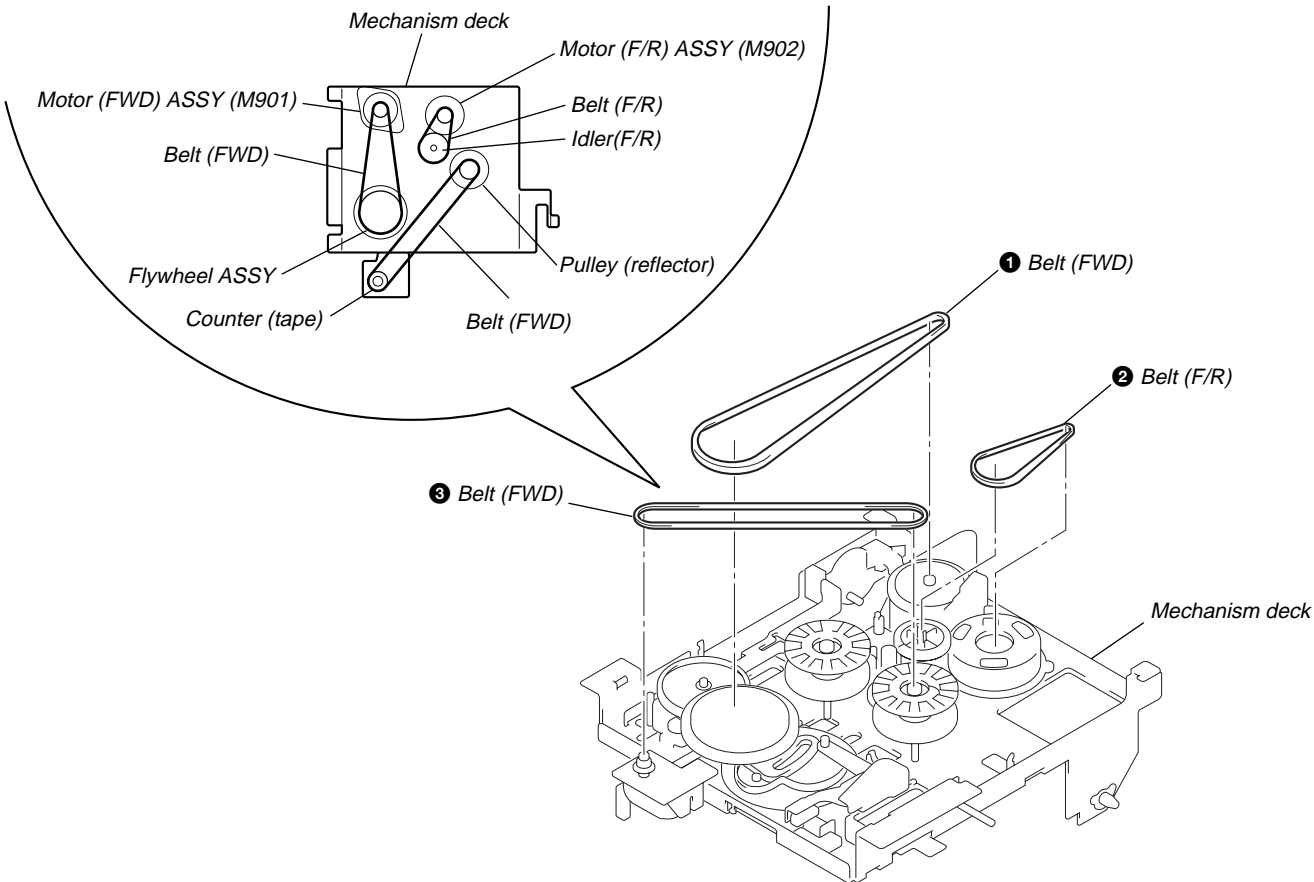

3-7. MOTOR (FWD) ASSY (M901)

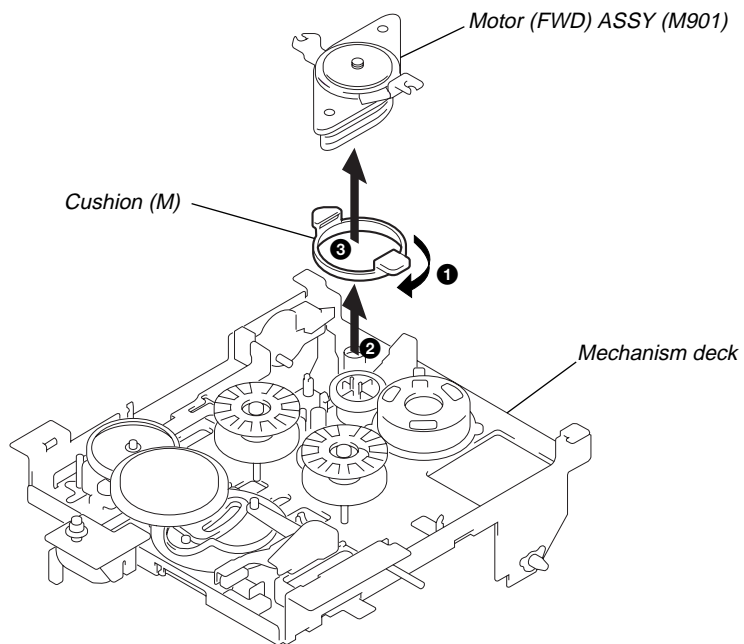

SECTION 4 MECHANICAL ADJUSTMENTS

PRECAUTION

1. Clean the following parts with a denatured alcohol moistened swab :

record/playback/erase head	pinch roller
rubber belts	capstan
2. Demagnetize the record/playback/erase head with a head demagnetizer.
3. Do not use a magnetized screwdriver for the adjustments.
4. After the head high adjustments, apply suitable locking compound to the parts adjusted.
5. The measurement and adjustments should be performed with the rated power supply voltage unless otherwise noted.

Torque Measurement

Mode	Torque Meter	Meter Reading
Forward	CQ-102C	20 to 45 g • cm (0.28 to 0.62 oz • inch)
Fast Forward Rewind	CQ-201B	80 to 200 g • cm (1.12 to 2.77 oz • inch)
Forward Back Tension	CQ-102C	4 to 8 g • cm (0.056 to 0.11 oz • inch)

Tape Tension Measurement

Mode	Tension Meter	Meter Reading
Forward	CQ-403A	100 to 170 g (3.53 to 5.99 oz)

Forward Torque Adjustment

Torque meter	Meter reading	Procedure
CQ-102C	20 to 45 g • cm (0.28 to 0.62 oz • inch)	Adjust the forward torque by replace the spacer in below chart.

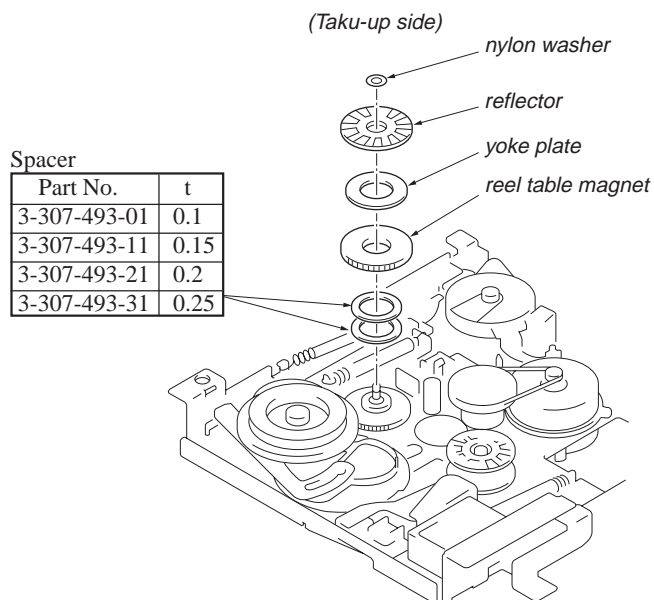

Head Height Adjustment

Procedure :

1. Insert the mirror cassette (CQ-009C).
2. In playback mode and viewing from the front, adjust the head heights to eliminate tape curl and tape twist at shown by arrows.
3. After the adjustments, apply suitable locking compound to screws.

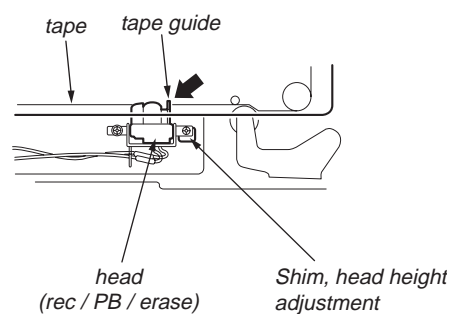

Part No.	t
3-578-138-01	0.1
3-578-138-11	0.2

SECTION 5

ELECTRICAL ADJUSTMENTS

PRECAUTION

1. Switches and controls should be set to the positions as follows unless otherwise specified.
 - Switch positions

POWER switch	: ON
AUTO STOP switch	: ON
SPEAKER switch	: BUILT-IN
TONE control	: max (H)
VOLUME control	: mechanical mid
SPEED CONTROL switch	: OFF
REVERSE TIME control	: 0
2. Standard Input Level :
TELEPHONE PICKUP jack : 300 Ω 0.77 mV (-60 dB)
3. Standard Output Level :
Speaker : 8 Ω 0.775 V (0 dB)

Record / playback / erase Head Azimuth Adjustment

Procedure :

1. Mode : Playback (LISTEN)

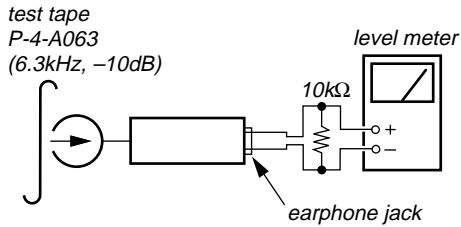

2. Turn the adjustment screw to obtain the maximum reading on level meter.
Adjustment should be finished with the screw in tightening direction.
3. After the adjustment, lock the adjustment screw with suitable locking compound.

Adjustment Location : record / playback / erase head

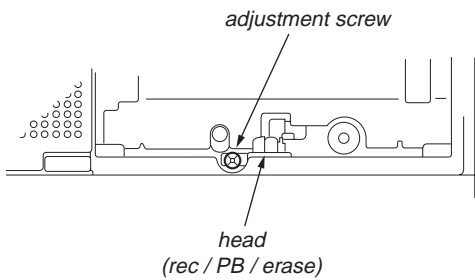

Tape Speed Adjustment

Setup :

Mode : Playback (LISTEN)

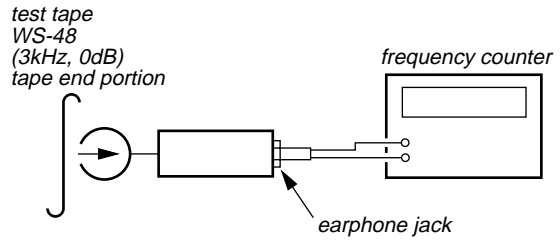

Procedure :

SPEED CONTROL switch : OFF

1. TAPE SPEED switch : 4.8cm/s
Adjust RV602 to obtain a 3,010Hz frequency reading.
Standard value : 3,000 - 3,020Hz
2. TAPE SPEED switch : 2.4cm/s
Adjust RV601 to obtain a 1,505Hz frequency reading.
Standard value : 1,500 - 1,510Hz

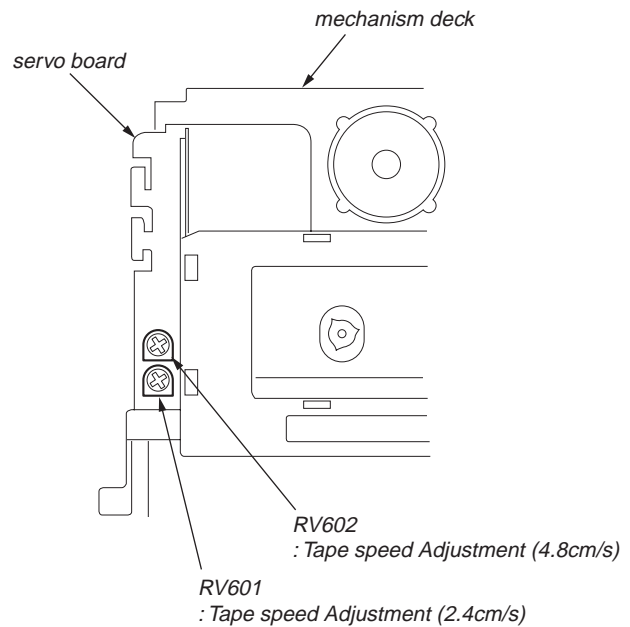

Adjustment Location : servo board



SECTION 6 DIAGRAMS

6-1. EXPLANATION OF IC TERMINALS

IC109 μ PD75308GF-J16-3B9 (SYSTEM CONTROL)

Pin No.	Pin name	I/O	Description												
1 – 12	S12 – S23	–	Not used (OPEN).												
13 – 16	KOUT 0 – KOUT 3	O	Key scan output.												
17	MA50 - OUT	–	Not used (OPEN).												
18	–	–	Not used (OPEN).												
19	4.8 / 2.4 - OUT	O	Tape speed change signal output.												
20	–	–	Not used (OPEN).												
21– 23	COM0 – COM2	–	Not used (OPEN).												
24	–	–	Not used (OPEN).												
25	LCD - BIAS	–	Conect to VSS.												
26 – 28	VLCD0 – VLCD2	–	Conect to VSS.												
29	$\overline{\text{FE}}$ -OUT	O	Fast-Erase control output. At Fast-Erase : “ L ” At the other : “ H ”												
30	$\overline{\text{BIAS}}$ -OUT	O	BIAS control output. At DICT, TEL-REC : 0V At the other : 5.9V												
31	$\overline{\text{BRK-PG}}$ -OUT	O	Brake plunger output. Normal : 6.0 V STOP from FF/REW : 												
32	$\overline{\text{STOP-PG}}$ -OUT	O	Stop plunger output. Normal : 0 V STOP from FWD : 												
33	VSS	–	GND												
34	$\overline{\text{FWD-PG}}$ -OUT	O	FWD plunger output. At FWD : “ H ” At the other : “ L ”												
35	$\overline{\text{FF-M}}$ -OUT	O	FF/REW motor output. <table border="1" style="margin-left: 20px;"> <thead> <tr> <th></th> <th>At motor FF</th> <th>At motor REW</th> <th>At the other</th> </tr> </thead> <tbody> <tr> <td>Pin35</td> <td>L</td> <td>H</td> <td>H</td> </tr> <tr> <td>Pin36</td> <td>H</td> <td>L</td> <td>H</td> </tr> </tbody> </table>		At motor FF	At motor REW	At the other	Pin35	L	H	H	Pin36	H	L	H
	At motor FF	At motor REW		At the other											
Pin35	L	H	H												
Pin36	H	L	H												
36	$\overline{\text{REW-M}}$ -OUT	O													
37	A-OFF-OUT	O	Motor Auto-off output. Motor Auto-off (no cassette or after three minutes after STOP) : “ H ” At the other : “ L ”												
38	STAND-BY	I	POWER switch input. POWER switch ON : “ H ” POWER switch OFF : “ L ”												
39	TAB-IN	I	TAB (erase proof) detection switch input. Cassette with TAB : “ L ” Cassette without TAB : “ H ”												
40	MC-IN	I	Cassette detection switch input. With a cassette : “ L ” Without a cassette : “ H ”												
41	CAS-IN	I	Cassette detection switch input. With a cassette : “ L ” Without a cassette : “ H ”												
42	SR	I	S reel signal input.												
43	TR	I	S reel signal input.												
44	$\overline{\text{DICT}}$ -IN	I	HU-DICT key input. At DICT key input of the hand control unit (HU-80) : “ L ” At the other : “ H ”												
45	LTR-DET	I	LTR signal input. Count the rectangular pulse with microcomputer <table border="1" style="margin-left: 20px;"> <thead> <tr> <th></th> <th>LTR</th> </tr> </thead> <tbody> <tr> <td>At FF/REW</td> <td>600 to 4,800HZ</td> </tr> </tbody> </table>		LTR	At FF/REW	600 to 4,800HZ								
	LTR														
At FF/REW	600 to 4,800HZ														

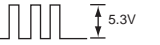
Pin No.	Pin name	I/O	Description
46	LTR-OUT	O	LTR signal output. At LTR oscillating :  Output 80Hz for three seconds. At the other : 5.3V
47	REC-OUT	O	DICT, TEL-REC control output. At DICT, TEL-REC : “ H ” At the other : “ L ”
48	TEL-OUT	O	TEL-REC control output. At TEL-REC : “ H ” At the other : “ L ”
49	ALM-OUT	O	Alarm output. At alarm oscillating :  2.05 kHz
50 – 53	KIN 0 – KIN 3	I	key scan input.
54	VDD	–	Positiv power source terminal of the microcomputer.
55	XT1	I	Microcomputer operation mode selection input. (Connect to VDD).
56	XT2	–	Not used (OPEN).
57	NC	–	Not used. Connect to VDD
58	X1	I	Input for clock oscillation (4.19MHz).
59	X2	O	Output for clock oscillation (4.19MHz).
60	$\overline{\text{HU-LIS-IN}}$	I	HU-LISTEN key input. At LISTEN key-in of the hand control unit (HU-80) : “ L ” At the other : “ H ”
61	BS-IN	I	HU-BS key input. At BS key-in of the hand unit (HU-80) : “ L ” At the other : “ H ”
62	PB-OUT	O	Playback control output. At LISTEN : “ H ” At the other : “ L ”
63	$\overline{\text{MUTE-OUT}}$	O	Amplifier mute output. At LISTEN, DICT, TEL-REC : “ H ” At the other : “ L ”
64	FS-IN	I	HU-FS key input. At FS key-in of the hand control unit (HU-80) : “ L ” At the other : “ H ”
65	PR-IN	I	Foot switch LISTEN key input. At LISTEN key-in of the foot control unit (FS-75) : “ L ” At the other : “ H ”
66	SEC-IN	–	Not used (Connect to VDD).
67	$\overline{\text{LTR-IN}}$	I	HU-LTR key input. At LTR key-in of the hand control unit (HU-80) : “ L ” At the other : “ H ”
68	$\overline{\text{RESET}}$	I	Microcomputer reset input. Normal : “ H ”
69 – 80	S0 – S11	–	Not used (OPEN).

6-2. BLOCK DIAGRAM

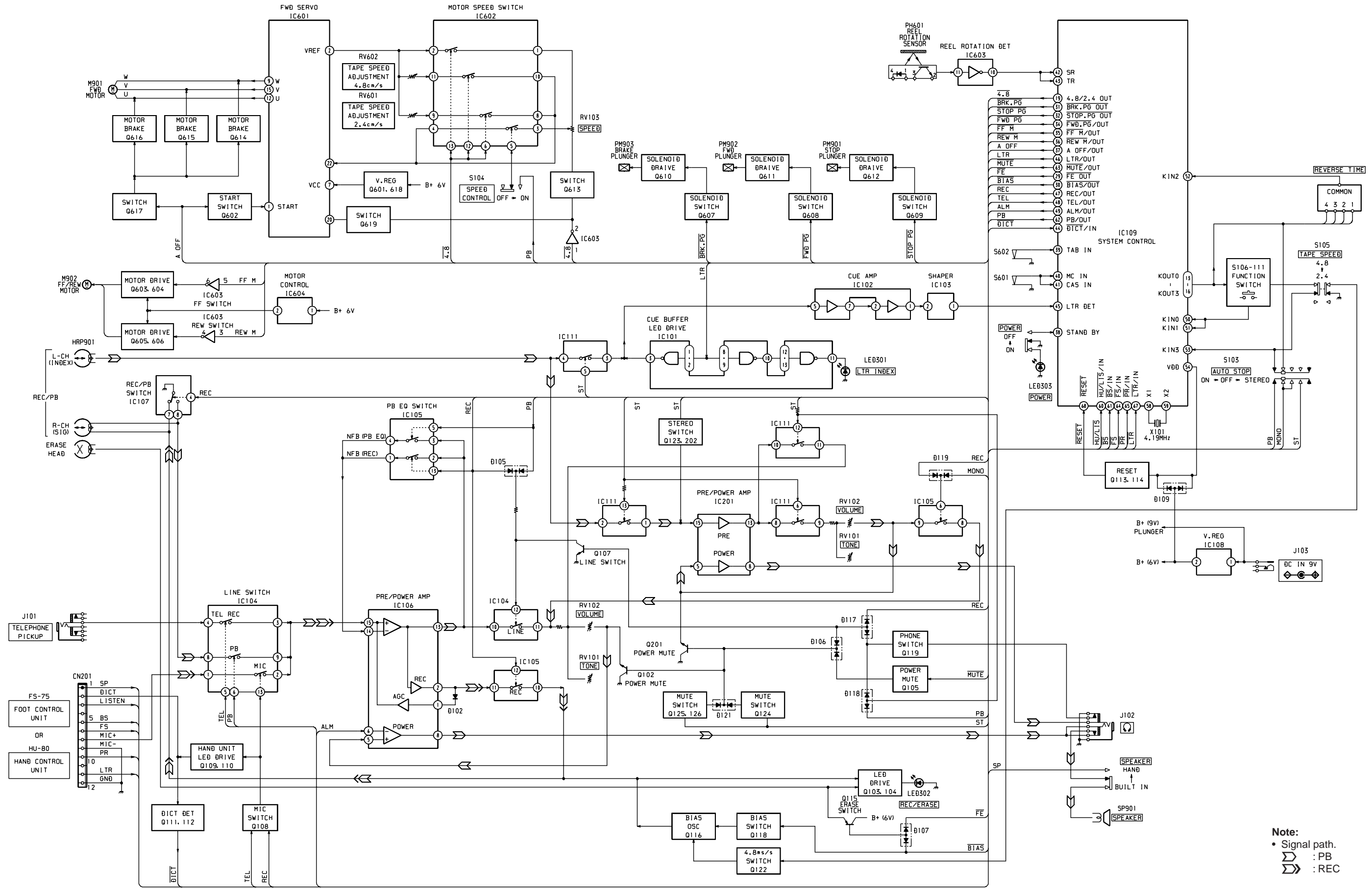

Note:
 • Signal path.
 $\langle \rangle$: PB
 $\langle \rangle$: REC

6-3. PRINTED WIRING BOARDS (SERVO SECTION)

● Semiconductor Location

Ref. No.	Location
D601	B-6
D604	G-6
D605	B-2
D606	G-6
IC601	B-4
IC602	E-6
IC603	F-3
IC604	D-4
Q601	B-6
Q602	C-2
Q603	E-3
Q604	E-3
Q605	E-3
Q606	E-3
Q607	G-4
Q608	C-2
Q609	G-2
Q610	F-6
Q611	B-2
Q612	G-5
Q613	E-5
Q614	C-3
Q615	C-3
Q616	C-3
Q617	C-2
Q618	B-6
Q619	B-6

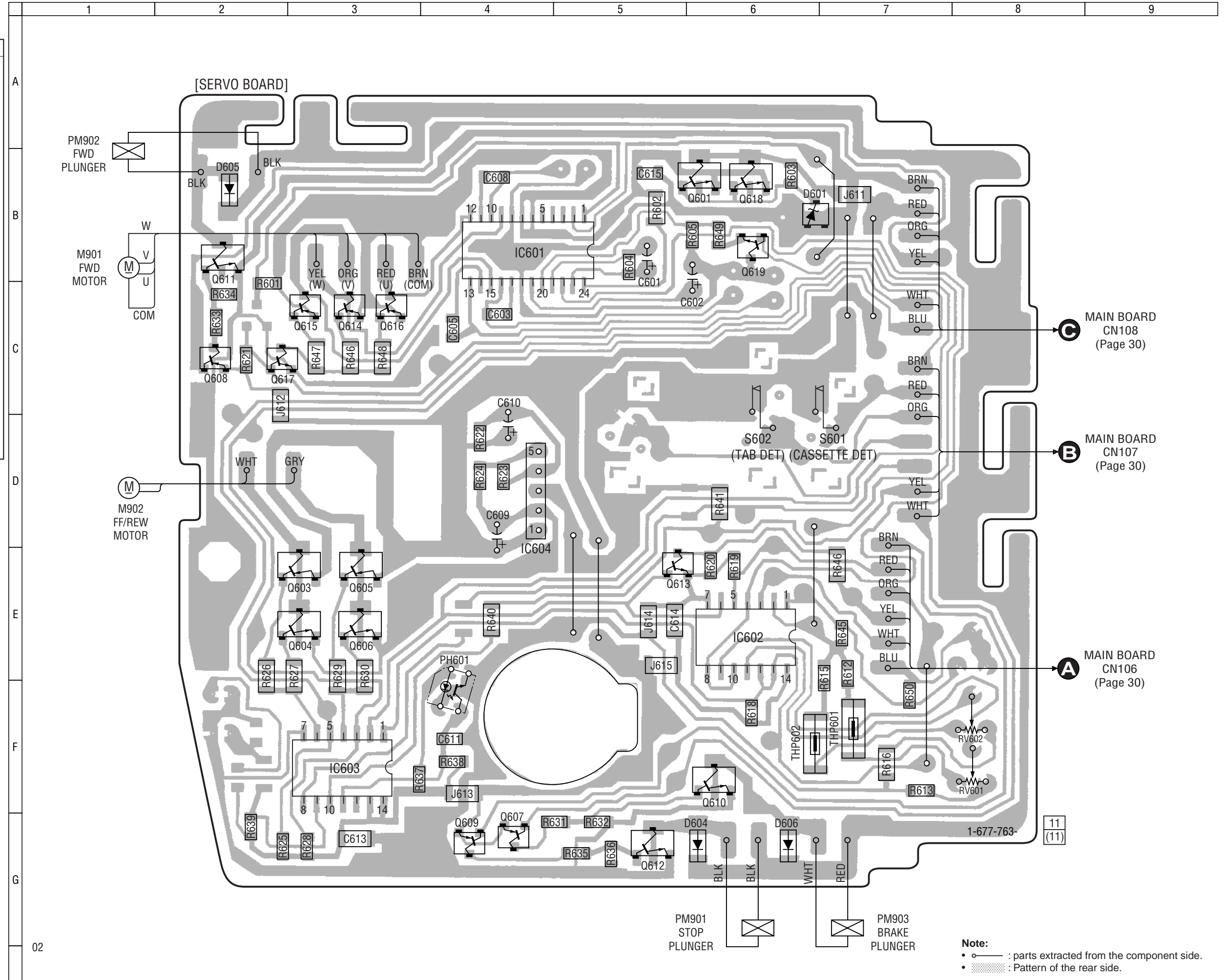

02

6-4. SCHEMATIC DIAGRAM (SERVO SECTION)

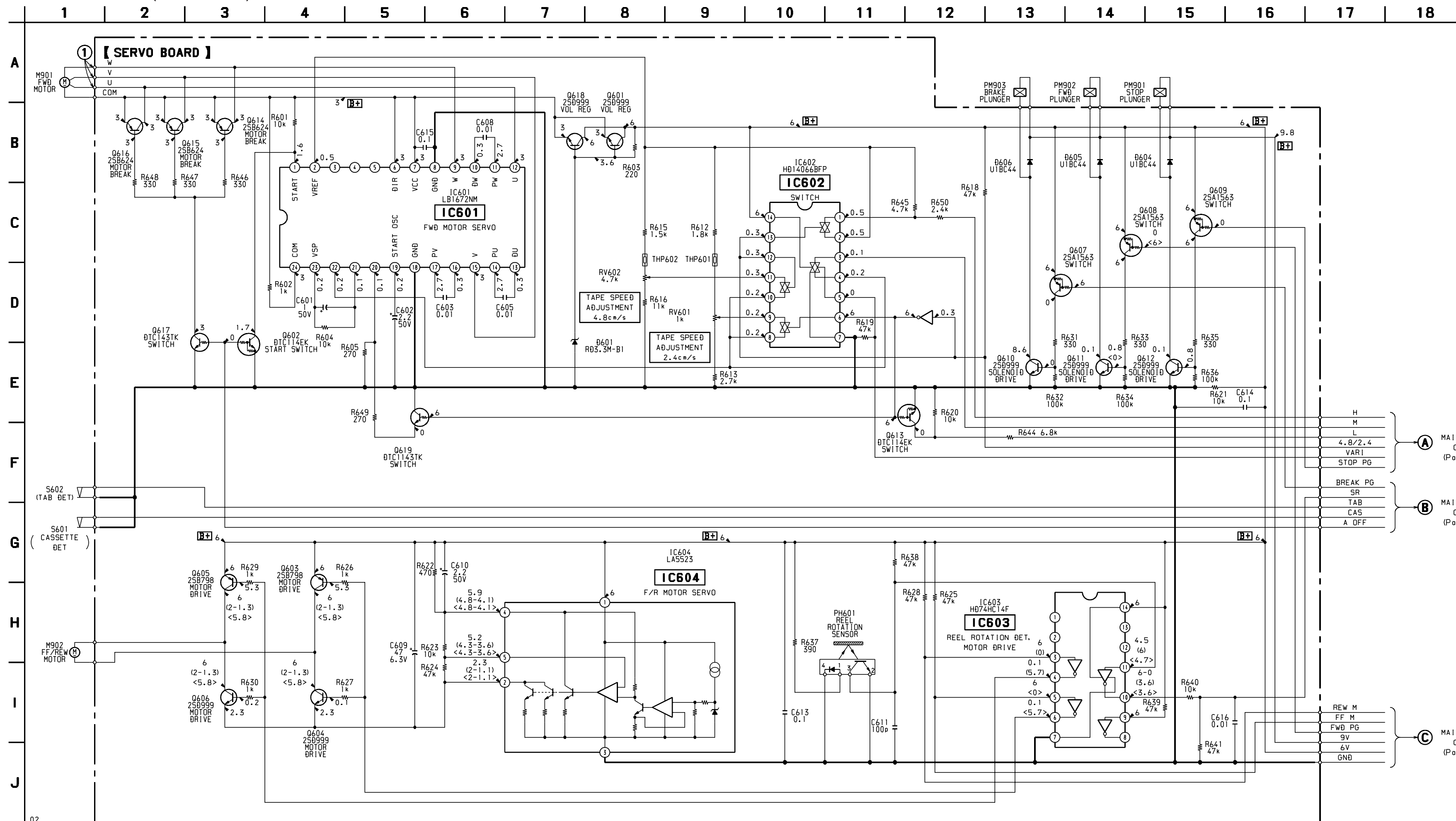

● Waveform

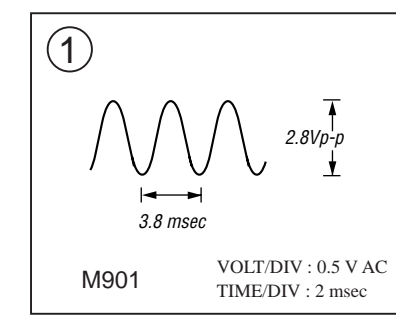

- Note:**
- All capacitors are in μF unless otherwise noted. pF: μF 50 WV or less are not indicated except for electrolytics and tantalums.
 - All resistors are in Ω and $\frac{1}{4}$ W or less unless otherwise specified.
 - [B+] : B+ Line.
 - [] : adjustment for repair.
 - Power voltage is dc 9 V and fed with regulated dc power supply from external power voltage jack (J103).
 - Voltages and waveforms are dc with respect to ground under no-signal conditions.
 - no mark : LISTEN
 - () : REW
 - < > : FF
 - Voltages are taken with a VOM (Input impedance 10 M Ω). Voltage variations may be noted due to normal production tolerances.
 - Waveforms are taken with an oscilloscope. Voltage variations may be noted due to normal production tolerances.
 - Circled numbers refer to waveforms.

6-5. PRINTED WIRING BOARDS (MAIN SECTION)

● Semiconductor Location

Ref. No.	Location	Ref. No.	Location
D101	F-4	IC108	C-2
D102	F-3	IC109	D-8
D104	C-3	IC110	G-3
D105	D-5		
D106	D-5	IC111	G-7
		IC201	G-6
D107	D-7		
D108	B-3		
D109	C-3	Q102	E-3
D110	C-10	Q103	C-6
D111	C-10	Q104	C-7
		Q105	C-5
D112	G-10	Q107	D-5
D113	D-10		
D114	C-11	Q108	C-6
D115	D-10	Q109	C-6
D116	D-11	Q110	C-6
		Q111	D-6
D117	D-5	Q112	D-6
D118	D-5		
D119	D-5	Q113	C-8
D120	C-10	Q114	C-8
D121	F-8	Q115	E-7
		Q116	E-7
		Q118	C-5
LE301	A-9		
LE302	A-8	Q119	G-9
LE303	A-8	Q120	C-9
		Q121	E-7
		Q122	G-8
		Q123	F-8
IC101	G-8		
IC102	H-5	Q124	F-8
IC103	H-4	Q125	F-8
IC104	F-5	Q126	F-8
IC105	E-4	Q201	G-6
		Q202	H-6
IC106	E-4		
IC107	F-7		

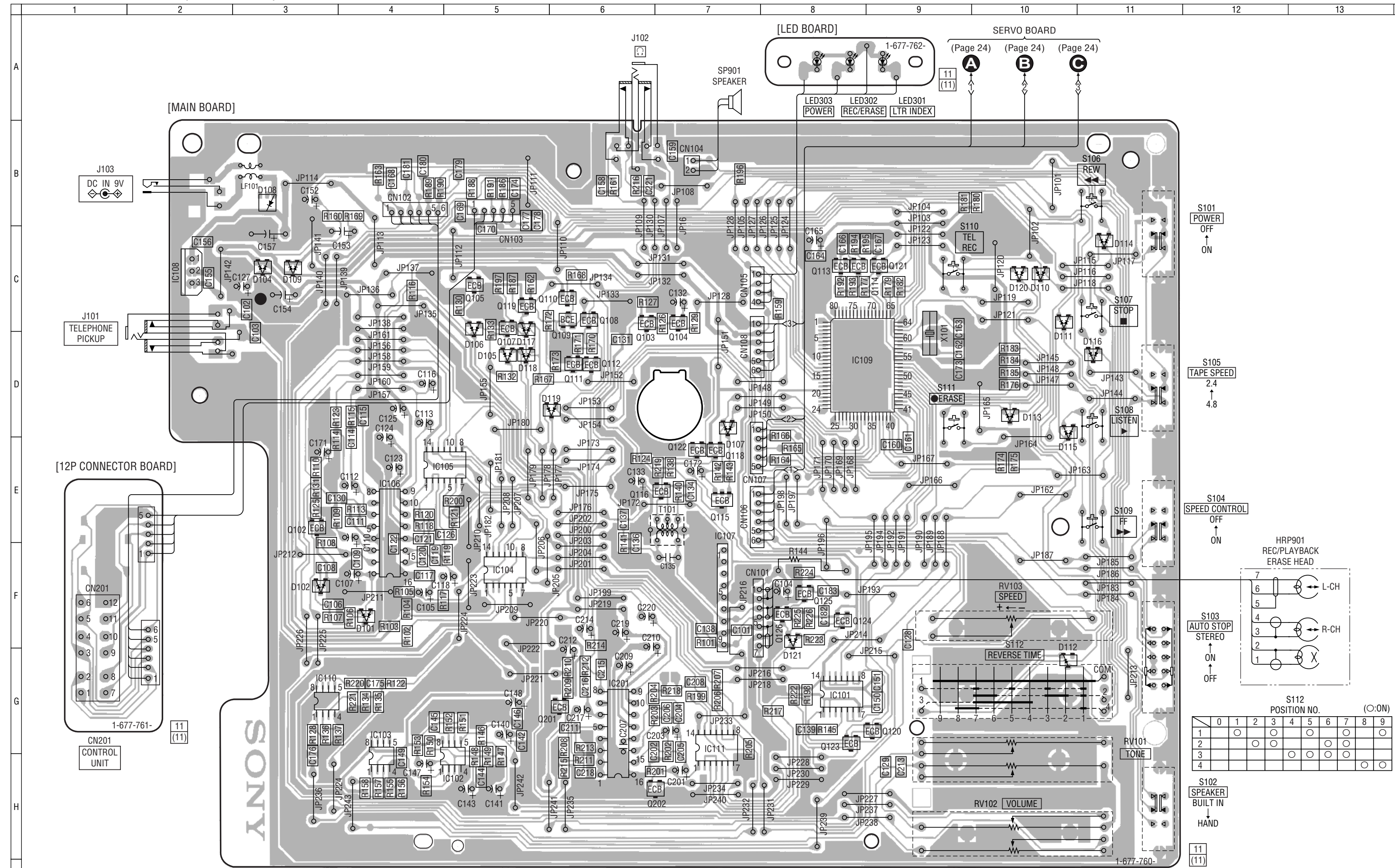

Note:
 ○ : parts extracted from the component side.
 ● : Pattern of the rear side.

S112 POSITION NO. (○:ON)

	0	1	2	3	4	5	6	7	8	9
1	○									
2		○								
3			○							
4				○						



6-6. SCHEMATIC DIAGRAM (MAIN SECTION)

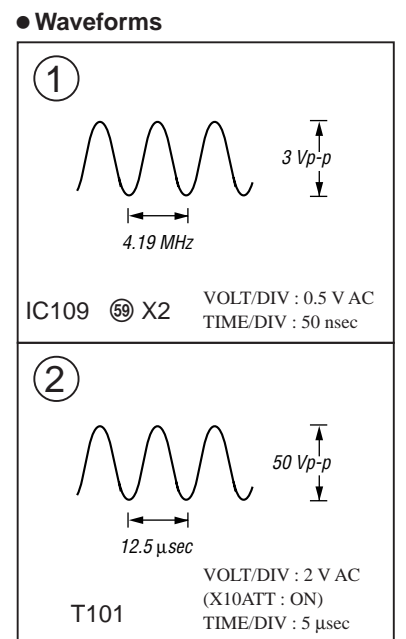
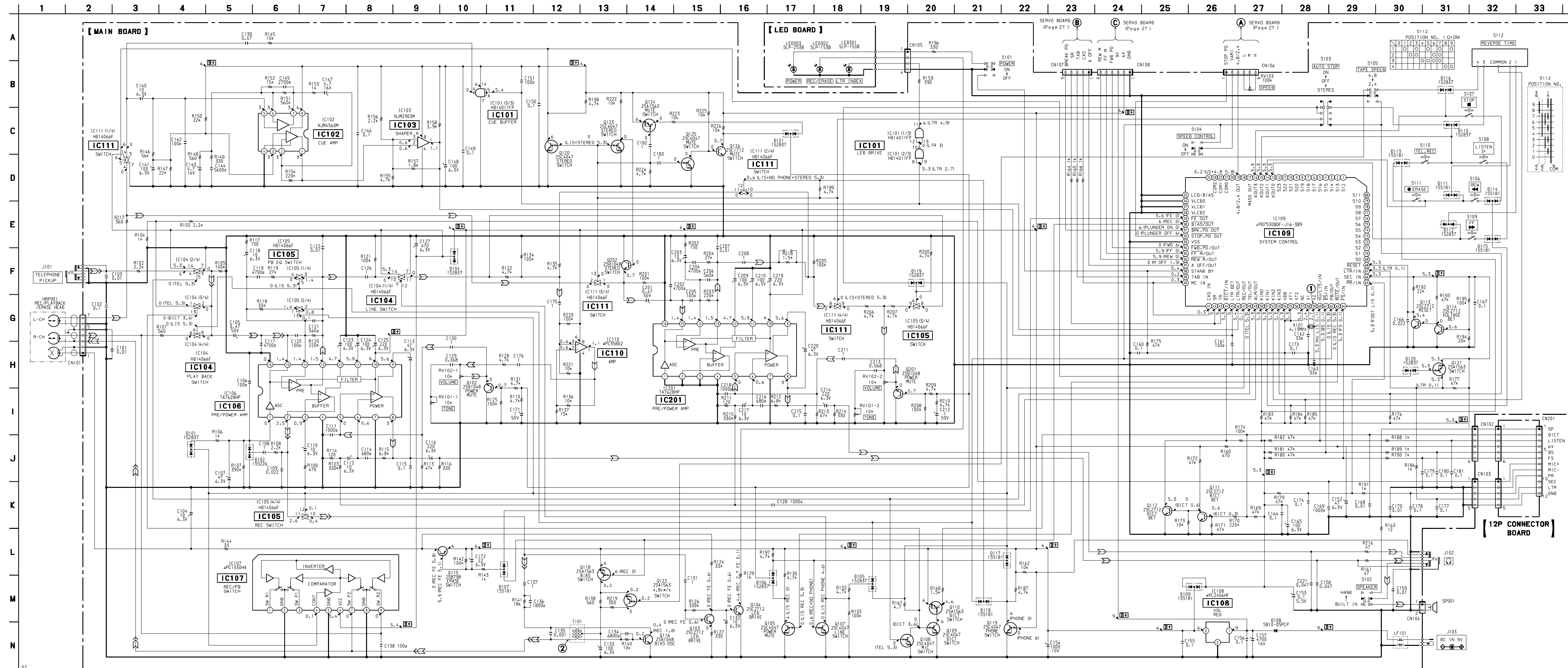

- Note:**
- All capacitors are in μF unless otherwise noted. pF: μF 50 WV or less are not indicated except for electrolytics and tantalums.
 - All resistors are in Ω and 1/4 W or less unless otherwise specified.
 - [B+]: B+ Line.
 - Power voltage is dc 9 V and fed with regulated dc power supply from external power voltage jack (J103).
 - Voltagess and waveforms are dc with respect to ground under no-signal conditions.
 - no mark : STOP
 - LIS : LISTEN
 - FE : FAST-ERASE
 - REC : DICT/TEL-REC
 - F : FF
 - R : REW
 - FWD : LISTN, DICT, TEL, LTR
 - M-OFF : MOTOR OFF
 - M-ON : MOTOR ON
 - NO-CAS : NO CASSETTE
 - HU-LIS : LISTN mode (HU-80)
 - FOOT-LIS : LISTN mode (FS-75)
 - Voltagess are taken with a VOM (Input impedance 10 MΩ). Voltage variations may be noted due to normal production tolerances.
 - Waveforms are taken with an oscilloscope. Voltage variations may be noted due to normal production tolerances.
 - Circled numbers refer to waveforms.
 - Signal path.
 - ⤴ : PB
 - ⤵ : REC

**SECTION 7
EXPLODED VIEWS**

NOTE :

- XX, -X mean standardized parts, so they may have some difference from the original one.
- Items marked " * " are not stocked since they are seldom required for routine service. Some delay should be anticipated when ordering these items.
- The mechanical parts with no reference number in the exploded views are not supplied.
- Hardware (# mark) list and accessories and packing materials are given in the last of this parts list.

7-1. CABINET SECTION

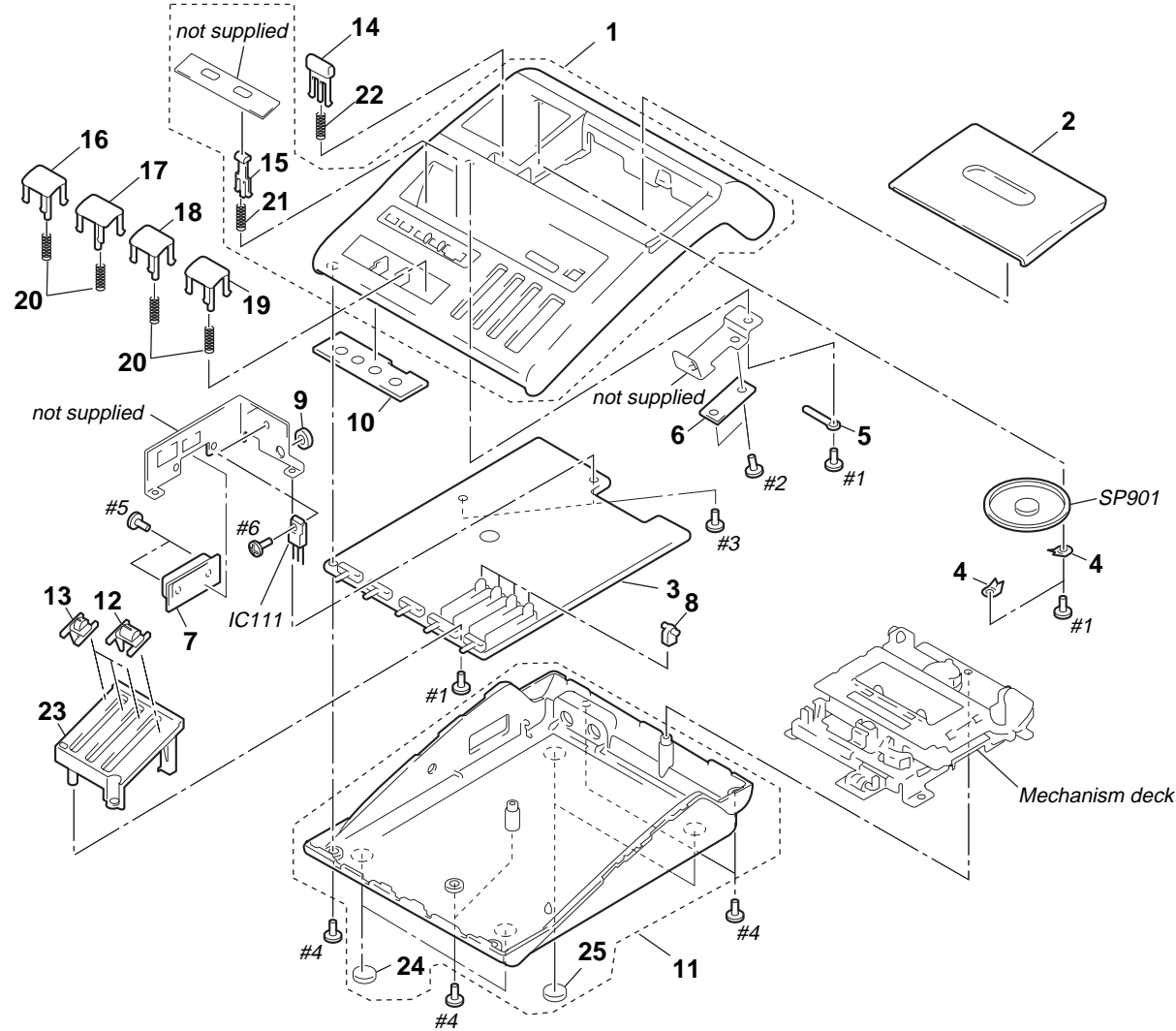

Ref. No.	Part No.	Description	Remark	Ref. No.	Part No.	Description	Remark
1	X-3378-708-1	CABINET (FRONT) ASSY		15	3-323-695-01	BUTTON	
2	X-3323-532-1	LID ASSY, CASSETTE		16	3-323-698-01	BUTTON (MD) (REW)	
* 3	A-3062-116-A	MAIN BOARD, COMPLETE		17	3-323-697-01	BUTTON (STOP)	
4	3-845-110-00	RETAINER, SPEAKER		18	3-323-698-11	BUTTON (MD) (LISTEN)	
5	3-701-822-01	HOLDER, WIRE		19	3-323-698-21	BUTTON (MD) (FF)	
* 6	1-677-762-11	LED BOARD		20	3-323-696-01	SPRING, COMPRESSION	
* 7	1-677-761-11	12P CONNECTOR BOARD		21	3-323-694-01	SPRING, COMPRESSION	
* 8	3-323-679-01	BUSHING		22	3-323-692-01	SPRING, COMPRESSION	
* 9	3-323-680-01	COVER, JACK		23	3-359-104-01	GUIDE, KNOB	
10	3-382-000-01	PLATE, MD BUTTON		24	3-343-250-01	CUSHION	
11	X-3378-709-1	CABINET (REAR) ASSY		25	3-329-013-01	FOOT, RUBBER	
12	X-3323-535-1	KNOB (VOL) ASSY		IC111	8-759-008-67	IC MC14066BF	
13	X-3323-536-1	KNOB (TONE) ASSY		SP901	1-544-282-11	SPEAKER	
14	3-323-693-01	BUTTON (EJECT)					

**7-2. MECHANISM DECK SECTION (1)
(MB-87-59)**

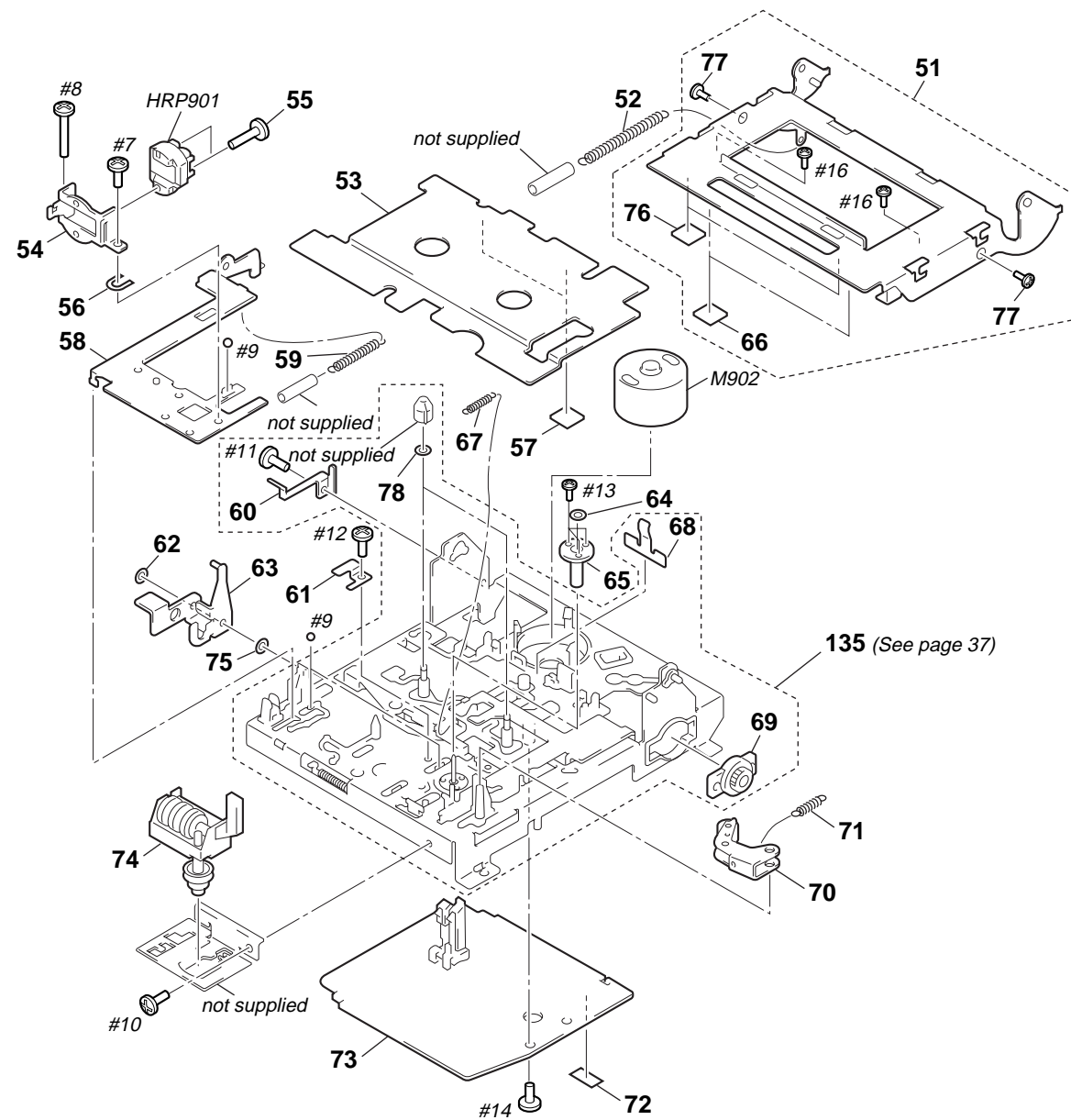

Ref. No.	Part No.	Description	Remark	Ref. No.	Part No.	Description	Remark
51	X-3323-552-1	HOLDER ASSY, CASSETTE		65	3-359-152-01	BEARING, CAPSTAN	
52	3-359-163-01	SPRING, TENSION		66	3-363-246-01	CUSHION (CH)	
53	3-359-159-01	PANEL (REEL)		67	3-305-902-00	SPRING, TENSION	
* 54	3-359-144-01	HOLDER (HEAD)		68	3-359-125-01	SPRING (CASSETTE RETAINER)	
55	4-920-347-01	SCREW, HEAD		69	3-343-248-01	DAMPER (P), SMALL	
56	3-578-138-01	SHIM (t=0.1)		70	X-3323-550-1	PINCH LEVER ASSY	
57	3-578-138-11	SHIM (t=0.2)		71	3-359-164-01	SPRING, TENSION	
58	3-831-441-99	CUSHION		72	3-831-441-11	LEVER (FWD)	
* 59	3-359-140-01	CHASSIS, HEAD		* 73	A-3021-329-A	SERVO BOARD, COMPLETE	
60	3-359-126-01	SPRING (CASSETTE HOLDER)		74	1-251-057-11	COUNTER, TAPE	
61	3-323-520-01	SPRING		75	3-701-439-11	WASHER	
62	3-307-948-21	WASHER, NYLON		* 76	2-387-601-01	CUSHION, RUBBER	
63	X-3323-551-1	LEVER (EJECT) ASSY		77	3-318-201-01	SCREW (B) (1.4X3), TAPPING	
64	3-325-698-01	RING, RETAINING		78	3-701-437-01	WASHER	
				HRP901	1-543-564-11	HEAD, MAGNETIC (REC/PB/ERASE)	
				M902	X-3362-206-1	MOTOR (F/R) ASSY	

**7-3. MECHANISM DECK SECTION (2)
(MB-87-59)**

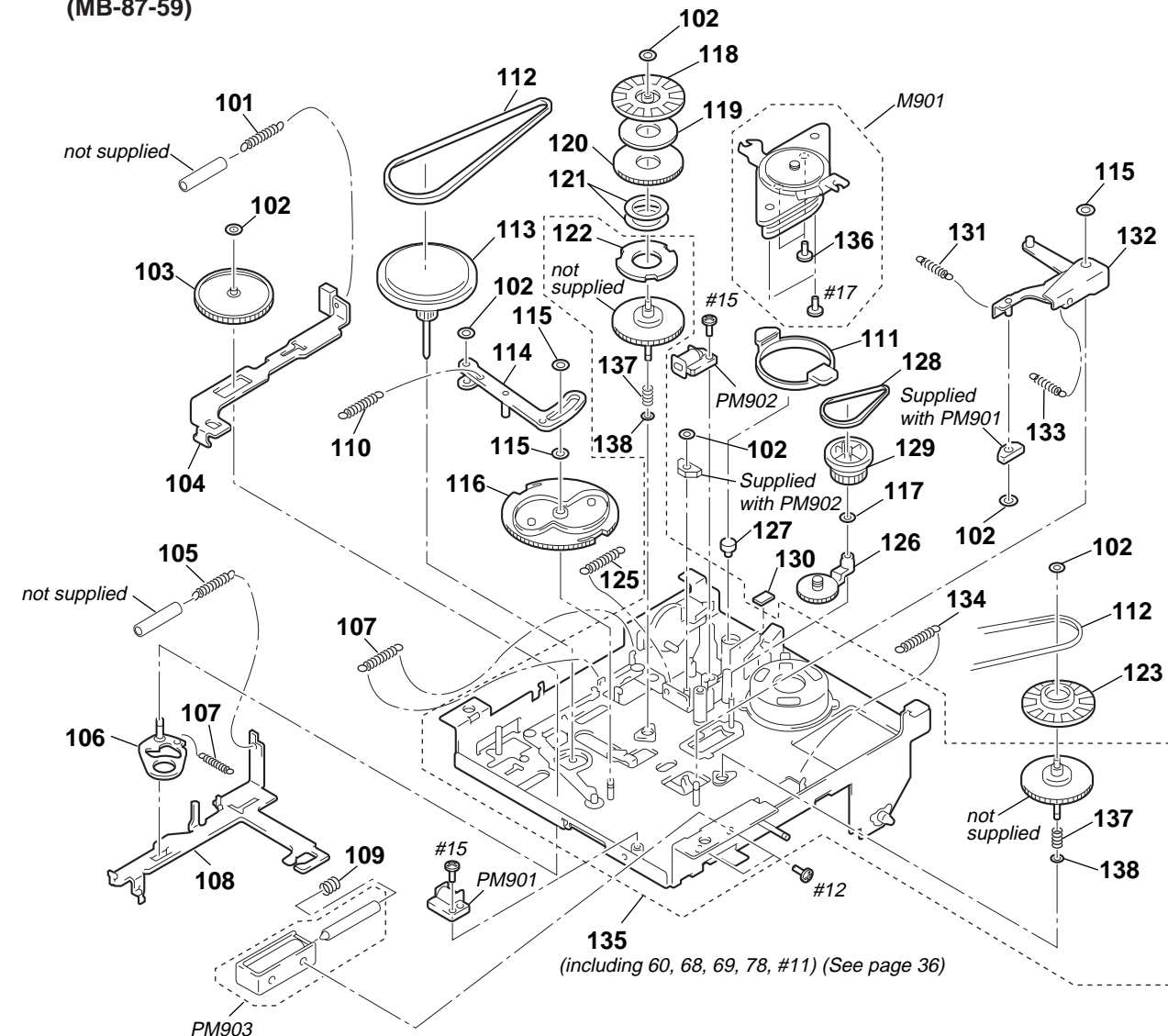

Ref. No.	Part No.	Description	Remark	Ref. No.	Part No.	Description	Remark
101	3-359-161-01	SPRING, TENSION		121	3-307-493-21	SPACER (t=0.15)	
102	3-307-948-01	WASHER, NYLON		122	3-561-827-00	PLATE (A), HYSTERESIS	
103	3-362-606-01	GEAR (FWD IDLER)		123	3-384-239-01	PULLEY (REFLECTOR)	
* 104	X-3323-544-1	PLATE ASSY, FUNCTION, FWD		125	3-309-031-00	SPRING, TENSION	
105	3-359-162-01	SPRING, TENSION		126	X-3323-547-1	GEAR (F/R) ASSY	
106	X-3323-501-1	LEVER ASSY, F1		* 127	3-362-434-01	CUSHION (M2)	
107	3-509-127-00	SPRING, TENSION		128	3-379-468-01	BELT (F/R)	
* 108	3-359-153-01	LEVER (FWD)		129	3-359-156-01	IDLER (F/R)	
109	3-359-160-01	SPRING, COMPRESSION		130	3-362-473-01	CUSHION (M3)	
110	3-555-212-00	SPRING, TENSION		131	3-533-223-00	SPRING, TENSION	
* 111	3-362-433-01	CUSHION (M)		* 132	X-3323-543-01	PLATE ASSY, FUNCTION, STOP	
112	3-359-158-01	BELT (FWD)		133	3-542-649-00	SPRING, COMPRESSION	
113	X-3362-056-1	FLYWHEEL ASSY		134	3-642-490-00	SPRING, TENSION	
* 114	X-3323-545-1	ARM (FWD DRIVING) ASSY		* 135	A-3035-282-A	CHASSIS ASSY	
115	3-307-948-21	WASHER, NYLON		136	3-727-902-01	SCREW (M1.4), SPECIAL	
116	3-359-154-01	GEAR (CAM)		137	3-323-519-01	SPRING, COMPRESSION	
117	3-701-437-01	WASHER		138	3-356-713-01	WASHER	
118	3-359-155-01	REFLECTOR		M901	X-3369-458-1	MOTOR (FWD) ASSY	
119	3-307-313-00	PLATE, YOKE		PM901	X-3362-935-1	SOLENOID ASSY (STOP)	
120	3-922-022-01	MAGNET, REEL TABLE		PM902	1-454-459-21	SOLENOID, PLUNGER (FWD)	
121	3-307-493-01	SPACER (t=0.1)		PM903	1-454-509-11	SOLENOID, PLUNGER (BRAKE)	
121	3-307-493-11	SPACER (t=0.15)					

12P CONNECTOR

LED MAIN

NOTE :

- Due to standardization, replacements in the parts list may be different from the parts specified in the diagrams or the components used on the set.
- XX, -X mean standardized parts, so they may have some difference from the original one.
- RESISTORS
All resistors are in ohms
METAL : Metal-film resistor
METAL OXIDE : Metal oxide-film resistor
F : nonflammable
- Items marked " * " are not stocked since they are seldom required for routine service. Some delay should be anticipated when ordering these items.

Ref. No.	Part No.	Description	Remark
* 1-677-761-11	12P CONNECTOR BOARD		
< CONNECTOR >			
* CN201	1-561-533-00	SOCKET, CONNECTOR 12P	
< DIODE >			
LED301	8-719-980-56	LED SLP-153B-51 (LTR INDEX)	
LED302	8-719-980-56	LED SLP-153B-51 (REC/ERASE)	
LED303	8-719-980-57	LED SLP-253B-51 (POWER)	
< CAPACITOR >			
C101	1-163-021-91	CERAMIC CHIP	0.01uF 10% 50V
C102	1-163-038-91	CERAMIC CHIP	0.1uF 20% 25V
C103	1-163-021-91	CERAMIC CHIP	0.01uF 10% 50V
C104	1-126-964-51	ELECT	10uF 20% 50V
C105	1-126-959-11	ELECT	0.47uF 20% 50V
C106	1-163-117-00	CERAMIC CHIP	100PF 5% 50V
C107	1-124-589-11	ELECT	47uF 20% 16V
C108	1-162-638-11	CERAMIC CHIP	1uF 16V
C109	1-163-037-11	CERAMIC CHIP	0.022uF 10% 25V
C110	1-126-964-51	ELECT	10uF 20% 50V
C111	1-163-009-11	CERAMIC CHIP	0.001uF 10% 50V
C112	1-126-964-51	ELECT	10uF 20% 50V
C113	1-124-589-11	ELECT	47uF 20% 16V
C114	1-163-007-11	CERAMIC CHIP	680PF 10% 50V
C115	1-164-004-11	CERAMIC CHIP	0.1uF 10% 25V
C116	1-124-635-00	ELECT	220uF 20% 6.3V
C117	1-162-625-11	CERAMIC CHIP	0.0047uF 5% 50V

**SECTION 8
ELECTRICAL PARTS LIST**

- SEMICONDUCTORS
In each case, u : μ , for example :
uA..... : μ A..... uPA..... : μ PA.....
uPB..... : μ PB..... uPC..... : μ PC.....
uPD..... : μ PD.....
uF : μ F
uH : μ H

The components identified by mark Δ or dotted line with mark Δ are critical for safety.
Replace only with part number specified.

When indicating parts by reference number, please include the board.

Ref. No.	Part No.	Description	Remark
C118	1-126-964-51	ELECT	10uF 20% 50V
C119	1-163-017-00	CERAMIC CHIP	0.0047uF 5% 50V
C120	1-163-117-00	CERAMIC CHIP	100PF 5% 50V
C121	1-163-006-11	CERAMIC CHIP	560PF 10% 50V
C122	1-163-021-91	CERAMIC CHIP	0.01uF 10% 50V
C123	1-124-584-00	ELECT	100uF 20% 10V
C124	1-124-584-00	ELECT	100uF 20% 10V
C125	1-124-635-00	ELECT	220uF 20% 6.3V
C126	1-162-638-11	CERAMIC CHIP	1uF 16V
C127	1-126-935-11	ELECT	470uF 20% 6.3V
C128	1-163-009-11	CERAMIC CHIP	0.001uF 10% 50V
C129	1-164-157-11	CERAMIC CHIP	0.068uF 10% 25V
C130	1-162-638-11	CERAMIC CHIP	1uF 16V
C131	1-162-638-11	CERAMIC CHIP	1uF 16V
C132	1-126-964-51	ELECT	10uF 20% 50V
C133	1-124-584-00	ELECT	100uF 20% 10V
C134	1-163-019-00	CERAMIC CHIP	0.0068uF 10% 50V
C135	1-106-343-00	MYLAR	1000PF 5% 200V
C136	1-163-012-00	CERAMIC CHIP	0.0018uF 10% 50V
C137	1-162-638-11	CERAMIC CHIP	1uF 16V
C138	1-163-117-00	CERAMIC CHIP	100PF 5% 50V
C139	1-162-637-11	CERAMIC CHIP	0.47uF 16V
C140	1-126-964-51	ELECT	10uF 20% 50V
C141	1-124-584-00	ELECT	100uF 20% 10V
C142	1-163-117-00	CERAMIC CHIP	100PF 5% 50V
C143	1-126-963-11	ELECT	4.7uF 20% 50V
C144	1-163-018-00	CERAMIC CHIP	0.0056uF 5% 50V
C145	1-163-014-00	CERAMIC CHIP	0.0027uF 10% 50V
C146	1-163-038-91	CERAMIC CHIP	0.1uF 25V
C147	1-126-963-11	ELECT	4.7uF 20% 50V
C148	1-124-584-00	ELECT	100uF 20% 10V
C149	1-163-038-91	CERAMIC CHIP	0.1uF 25V
C150	1-163-038-91	CERAMIC CHIP	0.1uF 25V
C151	1-163-117-00	CERAMIC CHIP	100PF 5% 50V
C152	1-124-589-11	ELECT	47uF 20% 16V
C153	1-125-710-11	DOUBLE LAYER	0.1F 5.5V
C154	1-126-926-11	ELECT	1000uF 20% 10V
C155	1-164-004-11	CERAMIC CHIP	0.1uF 25V
C156	1-164-004-11	CERAMIC CHIP	0.1uF 10% 25V
C157	1-126-937-11	ELECT	4700uF 20% 16V
C158	1-163-035-00	CERAMIC CHIP	0.047uF 50V
C159	1-163-021-91	CERAMIC CHIP	0.01uF 10% 50V
C160	1-163-077-00	CERAMIC CHIP	0.1uF 10% 25V

Ref. No.	Part No.	Description	Remark	Ref. No.	Part No.	Description	Remark
C161	1-163-117-00	CERAMIC CHIP	100PF 5% 50V	D104	8-719-914-43	DIODE DAN202K	
C162	1-163-239-11	CERAMIC CHIP	33PF 5% 50V	D105	8-719-914-43	DIODE DAN202K	
C163	1-163-239-11	CERAMIC CHIP	33PF 5% 50V	D106	8-719-914-43	DIODE DAN202K	
C164	1-164-004-11	CERAMIC CHIP	0.1uF 10% 25V	D107	8-719-820-05	DIODE 1SS181	
C165	1-124-584-00	ELECT	100uF 20% 10V	D108	8-719-938-78	DIODE SB10-05PCP	
C166	1-163-037-11	CERAMIC CHIP	0.022uF 10% 25V	D109	8-719-820-05	DIODE 1SS181	
C167	1-164-004-11	CERAMIC CHIP	0.1uF 10% 25V	D110	8-719-914-43	DIODE DAN202K	
C168	1-163-021-91	CERAMIC CHIP	0.01uF 10% 50V	D111	8-719-820-05	DIODE 1SS181	
C169	1-163-009-11	CERAMIC CHIP	0.001uF 10% 50V	D112	8-719-914-43	DIODE DAN202K	
C170	1-163-021-91	CERAMIC CHIP	0.01uF 10% 50V	D113	8-719-820-05	DIODE 1SS181	
C171	1-126-960-11	ELECT	1uF 20% 50V	D114	8-719-820-05	DIODE 1SS181	
C172	1-124-234-00	ELECT	22uF 20% 16V	D115	8-719-820-05	DIODE 1SS181	
C173	1-164-004-11	CERAMIC CHIP	0.1uF 10% 25V	D116	8-719-914-43	DIODE DAN202K	
C174	1-163-038-91	CERAMIC CHIP	0.1uF 25V	D117	8-719-820-05	DIODE 1SS181	
C175	1-162-638-11	CERAMIC CHIP	1uF 16V	D118	8-719-820-05	DIODE 1SS181	
C176	1-162-638-11	CERAMIC CHIP	1uF 16V	D119	8-719-914-43	DIODE DAN202K	
C177	1-163-038-91	CERAMIC CHIP	0.1uF 25V	D120	8-719-914-43	DIODE DAN202K	
C178	1-163-038-91	CERAMIC CHIP	0.1uF 25V	D121	8-719-914-43	DIODE DAN202K	
C179	1-163-077-00	CERAMIC CHIP	0.1uF 10% 25V			< IC >	
C180	1-163-077-00	CERAMIC CHIP	0.1uF 10% 25V	IC101	8-759-008-79	IC MC14011BF	
C181	1-163-077-00	CERAMIC CHIP	0.1uF 10% 25V	IC102	8-759-745-64	IC NJM4560M	
C182	1-162-638-11	CERAMIC CHIP	1uF 16V	IC103	8-759-700-07	IC NJM2903M	
C183	1-162-638-11	CERAMIC CHIP	1uF 16V	IC104	8-759-008-67	IC MC14066BF	
C201	1-126-959-11	ELECT	0.47uF 20% 50V	IC105	8-759-008-67	IC MC14066BF	
C202	1-162-625-11	CERAMIC CHIP	0.0047uF 5% 50V	IC106	8-759-230-04	IC TA7628HP	
C203	1-126-964-51	ELECT	10uF 20% 50V	IC107	8-759-143-54	IC uPC1330HA	
C204	1-163-017-00	CERAMIC CHIP	0.0047uF 5% 50V	IC108	8-759-390-48	IC uPC2406AHF	
C205	1-163-117-00	CERAMIC CHIP	100PF 5% 50V	IC109	8-759-081-10	IC uPD75308GF-J16-3B9	
C206	1-163-006-11	CERAMIC CHIP	560PF 10% 50V	IC110	8-759-510-71	IC BA10358F-E2	
C207	1-163-021-91	CERAMIC CHIP	0.01uF 10% 50V	IC111	8-759-008-67	IC MC14066BF	
C208	1-162-638-11	CERAMIC CHIP	1uF 16V	IC201	8-759-230-04	IC TA7628HP	
C209	1-124-584-00	ELECT	100uF 20% 10V			< JACK >	
C210	1-124-584-00	ELECT	100uF 20% 10V	J101	1-566-891-21	JACK (TELEPHONE PICK UP)	
C211	1-162-638-11	CERAMIC CHIP	1uF 16V	J102	1-566-891-11	JACK (⊕)	
C212	1-126-960-11	ELECT	1uF 20% 50V	J103	1-568-727-31	JACK, DC (DC IN 9V)	
C213	1-164-157-11	CERAMIC CHIP	0.068uF 10% 25V			< FILTER >	
C214	1-124-635-00	ELECT	220uF 20% 6.3V	LF101	1-424-361-11	FILTER, LINE	
C215	1-164-004-11	CERAMIC CHIP	0.1uF 10% 25V			< TRANSISTOR >	
C216	1-163-007-11	CERAMIC CHIP	680PF 10% 50V	Q102	8-729-800-37	TRANSISTOR 2SD1048-X7	
C217	1-126-964-51	ELECT	10uF 20% 50V	Q103	8-729-230-49	TRANSISTOR 2SC2712-YG	
C218	1-163-009-11	CERAMIC CHIP	0.001uF 10% 50V	Q104	8-729-230-49	TRANSISTOR 2SC2712-YG	
C219	1-124-635-00	ELECT	220uF 20% 6.3V	Q105	8-729-027-46	TRANSISTOR DTC114YKA-T146	
C220	1-124-589-11	ELECT	47uF 20% 16V	Q107	8-729-027-46	TRANSISTOR DTC114YKA-T146	
C221	1-163-035-00	CERAMIC CHIP	0.047uF 50V	Q108	8-729-027-46	TRANSISTOR DTC114YKA-T146	
		< CONNECTOR >		Q109	8-729-027-46	TRANSISTOR DTC114YKA-T146	
CN101	1-506-472-11	PIN, CONNECTOR 7P		Q110	8-729-901-46	TRANSISTOR DTA114YK	
* CN102	1-564-005-11	PIN, CONNECTOR 6P		Q111	8-729-230-49	TRANSISTOR 2SC2712-YG	
* CN103	1-564-004-11	PIN, CONNECTOR 5P		Q112	8-729-230-49	TRANSISTOR 2SC2712-YG	
* CN104	1-564-001-11	PIN, CONNECTOR 2P		Q113	8-729-230-49	TRANSISTOR 2SC2712-YG	
CN105	1-506-469-11	PIN, CONNECTOR 4P		Q114	8-729-230-49	TRANSISTOR 2SC2712-YG	
* CN106	1-564-005-11	PIN, CONNECTOR 6P		Q115	8-729-101-07	TRANSISTOR 2SB798-DL	
* CN107	1-564-004-11	PIN, CONNECTOR 5P		Q116	8-729-800-37	TRANSISTOR 2SD1048-X7	
CN108	1-506-471-11	PIN, CONNECTOR 6P		Q118	8-729-901-46	TRANSISTOR DTA114YK	
		< DIODE >					
D101	8-719-914-43	DIODE DAN202K					
D102	8-719-914-42	DIODE DA204K					

MAIN

Ref. No.	Part No.	Description	Remark	Ref. No.	Part No.	Description	Remark
Q119	8-729-027-46	TRANSISTOR	DTC114YKA-T146	R150	1-216-081-00	METAL CHIP	22K 5% 1/10W
Q120	8-729-027-46	TRANSISTOR	DTC114YKA-T146	R151	1-216-115-00	METAL CHIP	560K 5% 1/10W
Q121	8-729-901-46	TRANSISTOR	DTA114YK	R152	1-216-077-91	RES-CHIP	15K 5% 1/10W
Q122	8-729-901-46	TRANSISTOR	DTA114YK	R153	1-216-049-91	RES-CHIP	1K 5% 1/10W
Q123	8-729-027-46	TRANSISTOR	DTC114YKA-T146	R154	1-216-105-91	RES-CHIP	220K 5% 1/10W
Q124	8-729-901-46	TRANSISTOR	DTA114YK	R155	1-216-065-91	RES-CHIP	4.7K 5% 1/10W
Q125	8-729-027-46	TRANSISTOR	DTC114YKA-T146	R156	1-216-057-00	METAL CHIP	2.2K 5% 1/10W
Q126	8-729-230-49	TRANSISTOR	2SC2712-YG	R157	1-216-055-00	METAL CHIP	1.8K 5% 1/10W
Q201	8-729-800-37	TRANSISTOR	2SD1048-X7	R158	1-216-063-91	RES-CHIP	3.9K 5% 1/10W
Q202	8-729-800-37	TRANSISTOR	2SD1048-X7	R159	1-216-188-00	RES-CHIP	390 5% 1/8W
< RESISTOR >				R160	1-216-041-00	METAL CHIP	470 5% 1/10W
R101	1-216-043-91	RES-CHIP	560 5% 1/10W	R161	1-216-017-91	RES-CHIP	47 5% 1/10W
R102	1-216-057-00	METAL CHIP	2.2K 5% 1/10W	R162	1-216-073-00	METAL CHIP	10K 5% 1/10W
R103	1-216-057-00	METAL CHIP	2.2K 5% 1/10W	R163	1-216-152-11	RES-CHIP	12 5% 1/8W
R104	1-216-049-91	RES-CHIP	1K 5% 1/10W	R164	1-216-049-91	RES-CHIP	1K 5% 1/10W
R105	1-216-097-91	RES-CHIP	100K 5% 1/10W	R165	1-216-049-91	RES-CHIP	1K 5% 1/10W
R106	1-216-049-91	RES-CHIP	1K 5% 1/10W	R166	1-216-049-91	RES-CHIP	1K 5% 1/10W
R107	1-216-111-00	METAL CHIP	390K 5% 1/10W	R167	1-216-065-91	RES-CHIP	4.7K 5% 1/10W
R108	1-216-057-00	METAL CHIP	2.2K 5% 1/10W	R168	1-216-053-00	METAL CHIP	1.5K 5% 1/10W
R109	1-216-041-00	METAL CHIP	470 5% 1/10W	R169	1-216-089-91	RES-CHIP	47K 5% 1/10W
R110	1-216-065-91	RES-CHIP	4.7K 5% 1/10W	R170	1-216-105-91	RES-CHIP	220K 5% 1/10W
R113	1-216-089-91	RES-CHIP	47K 5% 1/10W	R171	1-216-089-91	RES-CHIP	47K 5% 1/10W
R114	1-216-027-00	METAL CHIP	120 5% 1/10W	R172	1-216-089-91	RES-CHIP	47K 5% 1/10W
R115	1-216-069-00	METAL CHIP	6.8K 5% 1/10W	R173	1-216-073-00	METAL CHIP	10K 5% 1/10W
R116	1-216-037-00	METAL CHIP	330 5% 1/10W	R174	1-216-097-91	RES-CHIP	100K 5% 1/10W
R117	1-216-029-00	METAL CHIP	150 5% 1/10W	R175	1-216-089-91	RES-CHIP	47K 5% 1/10W
R118	1-216-085-00	METAL CHIP	33K 5% 1/10W	R176	1-216-089-91	RES-CHIP	47K 5% 1/10W
R119	1-216-083-00	METAL CHIP	27K 5% 1/10W	R177	1-216-089-91	RES-CHIP	47K 5% 1/10W
R120	1-216-105-91	RES-CHIP	220K 5% 1/10W	R179	1-216-089-91	RES-CHIP	47K 5% 1/10W
R121	1-216-097-91	RES-CHIP	100K 5% 1/10W	R180	1-216-089-91	RES-CHIP	47K 5% 1/10W
R122	1-216-065-91	RES-CHIP	4.7K 5% 1/10W	R181	1-216-089-91	RES-CHIP	47K 5% 1/10W
R123	1-216-109-00	METAL CHIP	330K 5% 1/10W	R182	1-216-089-91	RES-CHIP	47K 5% 1/10W
R124	1-216-085-00	METAL CHIP	33K 5% 1/10W	R183	1-216-089-91	RES-CHIP	47K 5% 1/10W
R125	1-216-097-91	RES-CHIP	100K 5% 1/10W	R184	1-216-089-91	RES-CHIP	47K 5% 1/10W
R126	1-216-109-00	METAL CHIP	330K 5% 1/10W	R185	1-216-089-91	RES-CHIP	47K 5% 1/10W
R127	1-216-037-00	METAL CHIP	330 5% 1/10W	R186	1-216-049-91	RES-CHIP	1K 5% 1/10W
R128	1-216-065-91	RES-CHIP	4.7K 5% 1/10W	R187	1-216-065-91	RES-CHIP	4.7K 5% 1/10W
R129	1-216-049-91	RES-CHIP	1K 5% 1/10W	R188	1-216-049-91	RES-CHIP	1K 5% 1/10W
R130	1-216-065-91	RES-CHIP	4.7K 5% 1/10W	R189	1-216-049-91	RES-CHIP	1K 5% 1/10W
R131	1-216-065-91	RES-CHIP	4.7K 5% 1/10W	R190	1-216-049-91	RES-CHIP	1K 5% 1/10W
R132	1-216-065-91	RES-CHIP	4.7K 5% 1/10W	R191	1-216-049-91	RES-CHIP	1K 5% 1/10W
R133	1-216-097-91	RES-CHIP	100K 5% 1/10W	R192	1-216-081-00	METAL CHIP	22K 5% 1/10W
R134	1-216-097-91	RES-CHIP	100K 5% 1/10W	R193	1-216-089-91	RES-CHIP	47K 5% 1/10W
R135	1-216-065-91	RES-CHIP	4.7K 5% 1/10W	R194	1-216-080-00	METAL CHIP	20K 5% 1/10W
R136	1-216-073-00	METAL CHIP	10K 5% 1/10W	R195	1-216-097-91	RES-CHIP	100K 5% 1/10W
R137	1-216-077-91	METAL CHIP	15K 5% 1/10W	R196	1-216-186-00	RES-CHIP	330 5% 1/8W
R138	1-216-043-91	RES-CHIP	560 5% 1/10W	R197	1-216-065-91	RES-CHIP	4.7K 5% 1/10W
R140	1-216-073-00	METAL CHIP	10K 5% 1/10W	R198	1-216-065-91	RES-CHIP	4.7K 5% 1/10W
R141	1-216-079-00	METAL CHIP	18K 5% 1/10W	R199	1-216-065-91	RES-CHIP	4.7K 5% 1/10W
R142	1-216-097-91	RES-CHIP	100K 5% 1/10W	R200	1-216-065-91	RES-CHIP	4.7K 5% 1/10W
R143	1-216-049-91	RES-CHIP	1K 5% 1/10W	R201	1-216-097-91	RES-CHIP	100K 5% 1/10W
R144	1-215-883-11	METAL OXIDE	33 5% 2W	R202	1-216-029-00	METAL CHIP	150 5% 1/10W
R145	1-216-073-00	METAL CHIP	10K 5% 1/10W	R203	1-216-105-91	RES-CHIP	220K 5% 1/10W
R146	1-216-091-00	METAL CHIP	56K 5% 1/10W	R204	1-216-083-00	METAL CHIP	27K 5% 1/10W
R147	1-216-081-00	METAL CHIP	22K 5% 1/10W	R205	1-216-097-91	RES-CHIP	100K 5% 1/10W
R148	1-216-043-91	RES-CHIP	560 5% 1/10W	R206	1-216-065-91	RES-CHIP	4.7K 5% 1/10W
R149	1-216-037-00	METAL CHIP	330 5% 1/10W	R207	1-216-065-91	RES-CHIP	4.7K 5% 1/10W
				R208	1-216-097-91	RES-CHIP	100K 5% 1/10W

Ref. No.	Part No.	Description	Remark			Ref. No.	Part No.	Description	Remark		
R209	1-216-065-91	RES-CHIP	4.7K	5%	1/10W	C609	1-126-513-11	ELECT	47uF	20%	6.3V
R210	1-216-065-91	RES-CHIP	4.7K	5%	1/10W	C610	1-115-872-11	ELECT	2.2uF	20%	50V
R211	1-216-027-00	METAL CHIP	120	5%	1/10W	C611	1-163-251-11	CERAMIC CHIP	100PF	5%	50V
R212	1-216-069-00	METAL CHIP	6.8K	5%	1/10W	C613	1-163-077-00	CERAMIC CHIP	0.1uF	10%	25V
R213	1-216-089-91	RES-CHIP	47K	5%	1/10W	C614	1-163-077-00	CERAMIC CHIP	0.1uF	10%	25V
R214	1-216-037-00	METAL CHIP	330	5%	1/10W	C615	1-164-004-11	CERAMIC CHIP	0.1uF	10%	25V
R215	1-216-109-00	METAL CHIP	330K	5%	1/10W	C616	1-163-021-91	CERAMIC CHIP	0.01uF	10%	50V
R216	1-216-017-91	RES-CHIP	47	5%	1/10W	< DIODE >					
R217	1-216-043-91	RES-CHIP	560	5%	1/10W	D601	8-719-105-45	DIODE	RD3.3M-B1		
R218	1-216-053-00	METAL CHIP	1.5K	5%	1/10W	D604	8-719-054-58	DIODE	D1F20-TL		
R219	1-216-036-00	METAL CHIP	300	5%	1/10W	D605	8-719-054-58	DIODE	D1F20-TL		
R220	1-216-097-91	RES-CHIP	100K	5%	1/10W	D606	8-719-054-58	DIODE	D1F20-TL		
R221	1-216-073-00	METAL CHIP	10K	5%	1/10W	< IC >					
R222	1-216-222-00	RES-CHIP	10K	5%	1/8W	IC601	8-759-821-20	IC	LB1672M		
R223	1-216-073-00	METAL CHIP	10K	5%	1/10W	IC602	8-759-008-67	IC	MC14066BF		
R224	1-216-065-91	RES-CHIP	4.7K	5%	1/10W	IC603	8-759-925-80	IC	SN74HC14ANS		
R225	1-216-073-00	METAL CHIP	10K	5%	1/10W	IC604	8-759-801-12	IC	LA5523		
R226	1-216-073-00	METAL CHIP	10K	5%	1/10W	< JAMPER RESISTOR >					
< VARIABLE RESISTOR >						J611	1-216-296-91	SHORT	0		
RV101	1-237-901-11	RES, VAR, SLIDE	10K/10K		(TONE)	J612	1-216-296-91	SHORT	0		
RV102	1-237-901-11	RES, VAR, SLIDE	10K/10K		(VOLUME)	J613	1-216-296-91	SHORT	0		
RV103	1-237-364-11	RES, VAR, SLIDE	100K		(SPEED)	J614	1-216-296-91	SHORT	0		
< SWITCH >						J615	1-216-296-91	SHORT	0		
S101	1-572-251-11	SWITCH, SLIDE			(POWER)	< PHOTO INTERRUPTER >					
S102	1-572-251-11	SWITCH, SLIDE			(SPEAKER)	PH601	8-719-939-23	PHOTO	GP-2S09-C		
S103	1-571-212-11	SWITCH, SLIDE			(AUTO STOP)	< TRANSISTOR >					
S104	1-572-251-11	SWITCH, SLIDE			(SPEED CONTROL)	Q601	8-729-140-75	TRANSISTOR	2SD999-CLCK		
S105	1-572-251-11	SWITCH, SLIDE			(TAPE SPEED)	Q602	8-729-027-43	TRANSISTOR	DTC114EKA-T146		
S106	1-554-303-21	SWITCH, TACTILE			(REW)	Q603	8-729-101-07	TRANSISTOR	2SB798-DL		
S107	1-554-303-21	SWITCH, TACTILE			(STOP)	Q604	8-729-140-75	TRANSISTOR	2SD999-CLCK		
S108	1-554-303-21	SWITCH, TACTILE			(LISTEN)	Q605	8-729-101-07	TRANSISTOR	2SB798-DL		
S109	1-554-303-21	SWITCH, TACTILE			(FF)	Q606	8-729-140-75	TRANSISTOR	2SD999-CLCK		
S110	1-554-303-21	SWITCH, TACTILE			(TEL.REC)	Q607	8-729-901-46	TRANSISTOR	DTA114YK		
S111	1-554-303-21	SWITCH, TACTILE			(ERASE)	Q608	8-729-901-46	TRANSISTOR	DTA114YK		
S112	1-570-361-11	SWITCH, SLIDE			(DIGITAL CORD) (REVERS TIME)	Q609	8-729-901-46	TRANSISTOR	DTA114YK		
< TRANSFORMER >						Q610	8-729-140-75	TRANSISTOR	2SD999-CLCK		
T101	1-433-251-00	TRANSFORMER, BIAS			OSCILLATOR	Q611	8-729-140-75	TRANSISTOR	2SD999-CLCK		
< VIBRATOR >						Q612	8-729-140-75	TRANSISTOR	2SD999-CLCK		
X101	1-577-273-11	OSCILLATOR, CERAMIC			(4.19MHz)	Q613	8-729-027-43	TRANSISTOR	DTC114EKA-T146		

*	A-3021-329-A	SERVO BOARD, COMPLETE	*****								
< CAPACITOR >						Q614	8-729-141-48	TRANSISTOR	2SB624-BV345		
C601	1-126-960-11	ELECT	1uF	20%	50V	Q615	8-729-141-48	TRANSISTOR	2SB624-BV345		
C602	1-115-872-11	ELECT	2.2uF	20%	50V	Q616	8-729-141-48	TRANSISTOR	2SB624-BV345		
C603	1-163-021-91	CERAMIC CHIP	0.01uF	10%	50V	Q617	8-729-027-56	TRANSISTOR	DTC143TKA-T146		
C605	1-163-021-91	CERAMIC CHIP	0.01uF	10%	50V	Q618	8-729-140-75	TRANSISTOR	2SD999-CLCK		
C608	1-163-021-91	CERAMIC CHIP	0.01uF	10%	50V	Q619	8-729-027-56	TRANSISTOR	DTC143TKA-T146		
< RESISTOR >						R601	1-216-073-00	METAL CHIP	10K	5%	1/10W
R602	1-216-198-91	RES-CHIP	1K	5%	1/8W	R602	1-216-198-91	RES-CHIP	1K	5%	1/8W
R603	1-216-033-00	METAL CHIP	220	5%	1/10W	R603	1-216-033-00	METAL CHIP	220	5%	1/10W
R604	1-216-073-00	METAL CHIP	10K	5%	1/10W	R604	1-216-073-00	METAL CHIP	10K	5%	1/10W
R605	1-216-035-00	METAL CHIP	270	5%	1/10W	R605	1-216-035-00	METAL CHIP	270	5%	1/10W
R612	1-216-055-00	METAL CHIP	1.8K	5%	1/10W						

SERVO

Ref. No.	Part No.	Description	Remark
R613	1-216-059-00	METAL CHIP	2.7K 5% 1/10W
R615	1-216-053-00	METAL CHIP	1.5K 5% 1/10W
R616	1-216-223-00	RES-CHIP	11K 5% 1/8W
R618	1-216-089-91	RES-CHIP	47K 5% 1/10W
R619	1-216-089-91	RES-CHIP	47K 5% 1/10W
R620	1-216-073-00	METAL CHIP	10K 5% 1/10W
R621	1-216-073-00	METAL CHIP	10K 5% 1/10W
R622	1-216-041-00	METAL CHIP	470 5% 1/10W
R623	1-216-073-00	METAL CHIP	10K 5% 1/10W
R624	1-216-089-91	RES-CHIP	47K 5% 1/10W
R625	1-216-089-91	RES-CHIP	47K 5% 1/10W
R626	1-216-198-91	RES-CHIP	1K 5% 1/8W
R627	1-216-198-91	RES-CHIP	1K 5% 1/8W
R628	1-216-089-91	RES-CHIP	47K 5% 1/10W
R629	1-216-198-91	RES-CHIP	1K 5% 1/8W
R630	1-216-198-91	RES-CHIP	1K 5% 1/8W
R631	1-216-037-00	METAL CHIP	330 5% 1/10W
R632	1-216-097-91	RES-CHIP	100K 5% 1/10W
R633	1-216-037-00	METAL CHIP	330 5% 1/10W
R634	1-216-097-91	RES-CHIP	100K 5% 1/10W
R635	1-216-037-00	METAL CHIP	330 5% 1/10W
R636	1-216-025-91	RES-CHIP	100 5% 1/10W
R637	1-216-039-00	RES-CHIP	390 5% 1/10W
R638	1-216-089-91	RES-CHIP	47K 5% 1/10W
R639	1-216-089-91	RES-CHIP	47K 5% 1/10W
R640	1-216-222-00	RES-CHIP	10K 5% 1/8W
R641	1-216-238-91	RES-CHIP	47K 5% 1/8W
R644	1-216-218-00	RES-CHIP	6.8K 5% 1/8W
R645	1-216-065-91	RES-CHIP	4.7K 5% 1/10W
R646	1-216-186-00	RES-CHIP	330 5% 1/8W
R647	1-216-186-00	RES-CHIP	330 5% 1/8W
R648	1-216-186-00	RES-CHIP	330 5% 1/8W
R649	1-216-035-00	METAL CHIP	270 5% 1/10W
R650	1-216-058-00	RES-CHIP	2.4K 5% 1/10W
< VARIABLE RESISTOR >			
RV601	1-237-602-11	RES, ADJ, METAL GRAZE 1K (TAPE SPEED ADJUSTMENT 2.4cm/s)	
RV602	1-237-604-11	RES, ADJ, METAL GRAZE 4.7K (TAPE SPEED ADJUSTMENT 4.8cm/s)	
< SWITCH >			
S601	1-572-248-11	SWITCH, LEAF (CASSETTE DET)	
S602	1-571-281-11	SWITCH, LEAF (TAB DET)	
< THERMISTOR >			
THP601	1-809-132-11	THERMISTOR (POSITIVE)	
THP602	1-809-133-11	THERMISTOR (POSITIVE)	

MISCELLANEOUS			

74	1-251-057-11	COUNTER, TAPE	
IC111	8-759-008-67	IC MC14066BF	
HRP901	1-543-564-11	HEAD, MAGNETIC (REC/PB/ERASE)	
M901	X-3369-458-1	MOTOR (FWD) ASSY	
M902	X-3362-206-1	MOTOR (F/R) ASSY	

Ref. No.	Part No.	Description	Remark
PM901	1-454-459-31	SOLENOID, PLUNGER (STOP)	
PM902	1-454-459-21	SOLENOID, PLUNGER (FWD)	
PM903	1-454-509-11	SOLENOID, PLUNGER (BRAKE)	
SP901	1-544-282-11	SPEAKER	

ACCESSORIES & PACKING MATERIALS			

△	1-465-393-21	ADAPTOR, AC (AC-980F) (US)	
△	1-467-852-12	ADAPTOR, AC (AC-E90HG) (Australian)	
	1-473-066-11	REMOTE CONTROL UNIT	
	3-043-521-11	MANUAL, INSTRUCTION (ENGLISH)	
	8-953-342-92	HEADPHONE MDR-24	

HARDWARE LIST			

#1	7-685-646-79	SCREW +BVTP 3X8 TYPE2 N-S	
#2	7-621-772-10	SCREW +B 2X4	
#3	7-685-871-01	SCREW +BVTT 3X6 (S)	
#4	7-685-648-79	SCREW +BVTP 3X12 TYPE2 N-S	
#5	7-621-284-30	SCREW +P 2.6X8	
#6	7-682-548-04	SCREW +B 3X8	
#7	7-627-553-27	SCREW,PRECISION +P 2X2.5	
#8	7-621-771-06	SCREW, LOCK	
#9	7-671-111-11	STEEL, BALL 1.5MM	
#10	7-685-861-01	SCREW +BVTT 2.6X5 (S)	
#11	7-628-253-00	SCREW +PS 2X4	
#12	7-628-253-90	SCREW +PS 2.6X4	
#13	7-627-551-58	SCREW,PRECISION +P 1.4X3	
#14	7-685-533-14	SCREW +BTP 2.6X6 TYPE2 N-S	
#15	7-628-253-40	SCREW +PS 2X10	
#16	7-685-104-19	SCREW +P 2X6 TYPE2 NON-SLIT	
#17	7-628-253-35	SCREW +PS 2X8	

The components identified by mark △ or dotted line with mark △ are critical for safety.
Replace only with part number specified.

MEMO

