

SONY®
SERVICE MANUAL

AV-3600

VIDEOCODER

SONY CORPORATION

Schaltungsdienst Heinz Lange, Dng. grad. INH. M. TRAUTVETTER

CIRCUIT-DIAGRAM-SERVICE in GERMANY

SCHALTPLÄNE - SERVICEANLEITUNGEN - BEDIENUNGSANLEITUNGEN

SERVICE MANUAL

SONY®

SERVICE MANUAL

AV-3600

VIDEOCODER

SONY CORPORATION

SCHALTUNGSDIENST LANGE Berlin 47 Postfach 47 12 20 Tel. (030) 404 89 00
Postgiroamt Berlin-West Kto.Nr.726 60 - 100

SONY®

SERVICE MANUAL

AV-3600

VIDEOREORDER

U. S. PAT. 3,175,034
3,215,772
3,431,353

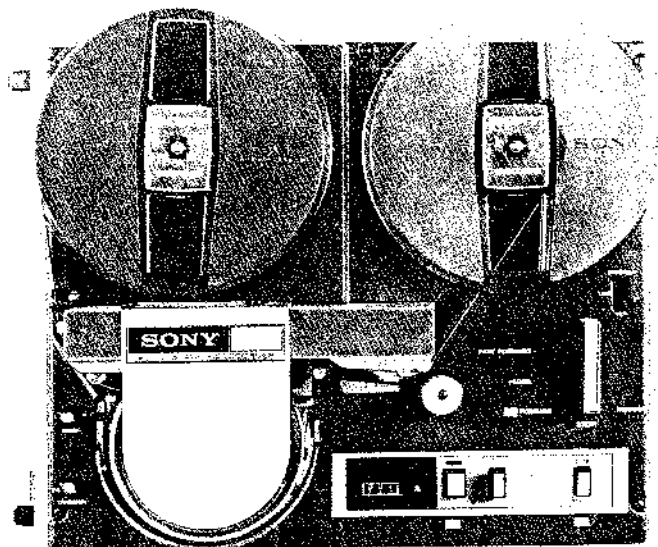

SONY CORPORATION

TABLE OF CONTENTS

<i>Section</i>	<i>Title</i>	<i>Page</i>	<i>Section</i>	<i>Title</i>	<i>Page</i>
1. GENERAL DESCRIPTION			5. VIDEO SYSTEM ALIGNMENT		
1-1.	Introduction	1-1	5-1.	Maximum Deviation Adjustment	5-2
1-2.	Specifications	1-1	5-2.	Carrier Leak Adjustment	5-4
1-3.	Operating Instructions	1-2	5-3.	Record Current Adjustment	5-4
1-4.	Input/Output Connections	1-3	5-4.	Playback Preamplifier Adjustment	5-5
2. CIRCUIT DESCRIPTION			6. SERVO SYSTEM ALIGNMENT		
2-1.	Video Circuits	2-1	6-1.	Free-Running Speed Check	6-2
2-2.	Servo Circuits	2-3	6-2.	Vertical Sync Separator Check	6-2
2-3.	Audio Circuits	2-6	6-3.	2 : 1 Frequency Divider Check	6-2
2-4.	Camera Control Circuits	2-6	6-4.	30-Hz Pulse Adjustment	6-3
2-5.	Power Supply Circuits	2-6	6-5.	30 PG Pulse Lock Phase Adjustment	6-3
	System Block Diagram	2-7	6-6.	Servo Response-Time Adjustment	6-3
3. DISASSEMBLY			6-7.	Playback Servo Check	6-4
3-1.	Cabinet Removal	3-1	6-8.	30 PG Pulse Position Check	6-4
3-2.	Removal of Control and Reel Panels	3-1	6-9.	30 PG Pulse Phase Check	6-6
4. MECHANICAL MAINTENANCE			6-10.	Servo-Reference Delay MV (Rec)	6-6
4-1.	Precautions	4-1	6-11.	Servo-Reference Delay MV (PB)	6-7
4-2.	Cleaning Heads and Slip Rings	4-1	6-12.	Tracking Control Check	6-7
4-3.	Lubrication	4-1	6-13.	Vertical Sync Former Check	6-8
4-4.	Drive-Belt Replacement	4-2	7. AUDIO SYSTEM ALIGNMENT		
4-5.	Drive Pulley Adjustment	4-2	7-1.	Audio/CTL Head Azimuth and Tilt Adjustments	1-2
4-6.	Video Head Replacement	4-3	7-2.	Playback Level Adjustment	1-2
4-7.	Tape Tension Brake Check	4-7	7-3.	Line Output Level Calibration	1-2
4-8.	Reel Table Height	4-8	7-4.	Bias/Erase Oscillator Check	1-3
4-9.	Audio/Control Head Replacement	4-8	7-5.	Audio Record Bias Setting	1-3
4-10.	Take-up Idler Adjustment	4-8	8. POWER SUPPLY ALIGNMENT		
4-11.	Rewind Idler Replacement	4-9	8-1.	Power Supply Adjustment	1-1
4-12.	Brake-System Adjustment	4-11	9. PRINTED CIRCUIT BOARD AND SCHEMATIC DIAGRAMS		
4-13.	Motor Replacement	4-13	9-1.	V2 Mod & Rec/PB Amp	1-3
4-14.	Record Button Latch Linkage	4-15	9-2.	V1 Limiter & Demod	1-5
4-15.	Automatic Shutoff Switch Adjustment	4-16			
4-16.	Capstan Bearing and Shaft Replacement	4-17			
4-17.	Capstan Deck Assembly Adjustment	4-19			
4-18.	Pinch Roller	4-19			
4-19.	Microswitch Maintenance and Adjustment	4-20			

<i>Section</i>	<i>Title</i>	<i>Page</i>
9-3.	SV Servo	9-7
9-4.	A Audio	9-9
9-5.	R2, R Voltage Regulator	9-11
9-6.	SY3 Vertical Sync Former	9-13
	Schematic Diagram	insert

10. ELECTRICAL PARTS LIST

10-1.	V2 Video Amp, Modulator & Rec/PB Amp	10-1
10-2.	V1 Limiter & Demodulator	10-3
10-3.	SV Servo	10-4
10-4.	A Audio	10-6
10-5.	R/R2 Voltage Regulator	10-7
10-6.	SY3 Sync Former	10-7
10-7.	Frame	10-8

<i>Section</i>	<i>Title</i>	<i>Page</i>
----------------	--------------	-------------

11. EXPLODED VIEWS WITH PART NUMBERS

11-1.	Cabinet Assembly	11-2
11-2.	Reel Panel and Sash	11-3
11-3.	Head Drum Assembly	11-4
11-4.	Capstan Deck Assembly and Motor	11-5
11-5.	Tape Transport 1	11-6
11-6.	Tape Transport 2	11-7
11-7.	Record Switch Linkage	11-8
11-8.	Power Supply Block and Microswitches	11-9
11-9.	Connector Panel and Others	11-10
11-10.	Hardware Parts List	11-11

SECTION 1

GENERAL DESCRIPTION

1-1. INTRODUCTION

This manual provides service information for the SONY AV-3600 Videocorder. It does not include information pertaining to special equipment applications, nor does it include instructions for performing factory-type repairs.

1-2. SPECIFICATIONS

Type EIA Japan type-1 video tape recorder

Video Recording System

Recording system: Rotary two-head slant-track scanning

Recording signal: 2 : 1 interlace composite video signal based on American TV standards using EIA or industrial sync.

Modulation system: Frequency modulation

Interchangeability: Recordings made on all AV series Videocorders are interchangeable.

Operating Characteristics

Tape: 1/2 inch (12.7 mm) width on 7-inch reel maximum.

Tape speed: 7.5 inches per second (19.05 cm per second)

Recording time: 60 minutes (continuous) using SONY V-32 tape
30 minutes (continuous) using SONY V-31 tape

Rewind time: Within 7 minutes for a full 7-inch reel

Operating position: Horizontal only

Video Characteristics

Input: 0.5 to 2 V (p-p), sync negative, 75 ohms unbalanced, internally terminated

Camera input: 0.5 to 2 V (p-p), sync negative, 75 ohms unbalanced, internally

terminated, for SONY AVC series cameras.

Output: 1.0 V (p-p), sync negative, for a 75-ohm load, unbalanced.

Resolution: Greater than 300 lines

Signal-to-noise ratio: Greater than 40 dB

Audio Characteristics

Microphone input: -65 dB, 600 ohms, unbalanced

TV input: -20 dB, high impedance, unbalanced

Auxiliary input: -0 dB, high impedance, unbalanced

Line output: 0 dB, 10 k ohms, unbalanced

Frequency range: 80 to 10,000 Hz

Signal-to-noise ratio: Greater than 40 dB

Flutter and wow: Less than 0.2%

Camera Control Signal

V. D.: 60 Hz, negative pulse, 2 V (p-p, with 75 ohm load), unbalanced

Rf Signal (When the RF unit is used)

Rf output: 80 dB (0 dB = 1 μ V), 75 ohms

General

Semiconductors: 5 IC s, 56 transistors (including 5 FETs) and 32 diodes

Power requirements: 117 V ac (\pm 10%), 60 Hz (\pm 0.5%)

Power consumption: 60 watts

AC outlet: 117 V, 500 watts maximum

Ambient temperature: 32° F (0°C) to 104° F (40° C)

Dimensions: 15-3/4" (W) x 9-1/16" (H) x 13-3/16" (D)
(400 x 233 x 335 mm)

Weight: 33 lb (15 kg)

1-3. OPERATING INSTRUCTIONS

PRECAUTIONS

1. To prevent accidental damage or needless wear to the video heads, observe the following.
 - a. Do not operate the motor (Function Lever in FAST FORWARD, PAUSE, FORWARD, or REWIND position) unless tape is threaded properly on the machine.
 - b. Never attempt to thread the tape while the motor is running.
 - c. At the end of record or playback operations, set the Function Lever to STOP.
 - d. Avoid leaving the motor running for extended periods while the tape is stationary.
 - e. Do not operate the Function Lever if the tape is slack anywhere in the tape path.
2. To prevent erasure of a prerecorded tape, do not put the VTR in the record mode while the prerecorded tape is on the machine. Tape erasure takes place when the RECORD button is down and the Function Lever is in the FORWARD position.

Preliminary Setup

1. Press the POWER button. The pilot lamp will light.
2. Set the Tape Counter to 000 by pressing the reset button at the right of the counter.
3. Set the CAMERA/LINE/TV Selector according to the input signal.

Record Mode

1. To put the VTR into the "E-to-E" mode, press the red RECORD button down until it locks in the "down" position. The red RECORD indicator button will light.
2. To start the recording, hold the RECORD button down while moving the Function Lever to FORWARD. This locks the RECORD button down in the record position. The automatic gain control system adjusts video and audio input levels automatically.
3. To stop the recording, move the Function Lever to the STOP position. The RECORD button is released and the VTR reverts to the playback mode.

Playback Mode

1. The VTR operates in the playback mode as long as the RECORD button is not depressed. Note that the monitor will display a snowy raster as the playback circuits have no input signals.
2. To play a prerecorded tape, set the Function Lever to FORWARD. The monitor will display the pictures previously recorded on the tape.
3. For stop-action, set the Function Lever to PAUSE. The tape transport will stop and the monitor will display a still picture.
4. To skip over a portion of tape, move the Function Lever to the FAST FORWARD position. The tape will advance rapidly. To resume normal playback, set the Function Lever to PAUSE and then to FORWARD. Tape will move again at the normal playing speed.
5. To stop the playback operation, set the Function Lever to STOP.

SKEW Control

Picture distortion in the upper part of the screen may be corrected by turning the SKEW control. This knob automatically returns to its center position when the RECORD button is pressed.

TRACKING Control

Noise in the picture due to improper tracking may be corrected by turning the TRACKING control. For normal playback, turn the knob fully counterclockwise to the FIX position.

Sound Dubbing

To insert (dub) new sound onto a prerecorded tape, proceed as follows.

1. Connect a microphone (or other audio source) to the VTR. Refer to Section 1-4 for audio input connection.

Note: When a microphone is connected, the auxiliary input at the AUX. IN jack is disabled.

2. Set the CAMERA/LINE/TV selector to CAMERA or LINE.
3. Play back the prerecorded tape. When the portion on which the new sound is to be added is seen or

the monitor screen, push the AUDIO DUB switch down. Sound dubbing will start.

4. At the end of the dub, set the Function Lever to STOP.

Playback on a Conventional TV

A conventional TV receiver can also be used for playback display by adapting the RF Unit (optional) to the Videocorder.

1. Remove the cover of the RF Unit compartment.
2. Insert the RF Unit (RFU-53W or 54W whichever channel is inactive in your area) into the compartment and connect the Videocorder, Antenna Selector and TV receiver as shown in Fig. 1-1.

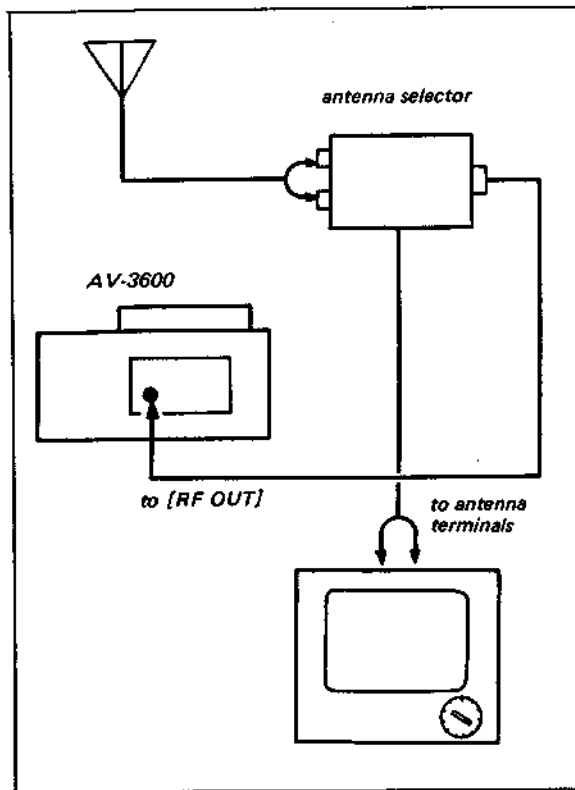

Fig. 1-1. RF Unit connections

3. Set the ANT/VTR switch on the Antenna Selector to VTR.
4. Set the TV channel selector to the channel to which the RF Unit is set.
5. Set the Videocorder to the playback mode.
6. Adjust the fine tuning knob for the best picture.

1-4. INPUT/OUTPUT CONNECTIONS

Figure 1-2 shows all input and output terminals, and output-signal characteristics. Normal connections to the monitor are made at 8-pin jack marked TV. Normal camera connections are made at the 6-pin CAMERA receptacle. Signal and power connections to other accessory equipment are as shown.

- A. Power Cord Receptacle [AC IN 117V 60 Hz]. Connects to a three-wire (parallel-ground) ac receptacle.
- B. Power Output Receptacle, unswitched [AC OUT 117V 500W]. Line output to power a monitor or camera. Max. rating 500 watts.
- C. TV-Monitor Jack [TV]. Provides all signal connections to and from the monitor. See detail.
- D. Fuse [1.5A] Contains a 1.5-ampere fuse.
- E. Audio Out Jack [LINE OUT]. Provides an additional audio-output feed to supply playback monitors or other audio components. Signal level: 0 dB (0.775V) across high impedance. This jack is in parallel with pins 1 and 5 (5 grounded) of the TV jack.
- F. Auxiliary Input Jack [AUX. IN]. Provides an alternative audio input for high impedance microphones, studio feeds, record players, and other audio sources. Signal level requirements: -20 dB across high impedance.
- G. Microphone Input Jack [MIC IN]. Signal feed point for a SONY microphone or other microphone with similar characteristics. Signal level requirements: -60 dB, 600 ohms, single ended.
- H. Camera Jack [CAMERA]. Provides video and sync connections to the camera. See detail.
- I. UHF Input Connector [VIDEO IN]. Provides video input connection for a camera or TV monitor equipped a video-output UHF connector.
- J. UHF Output Connector [VIDEO IN]. Provides an additional video-output feed to supply a monitor having a video-input UHF connector.
- K. RF Output Jack [RF OUT]. Supplies output to the antenna terminals of a conventional TV receiver when the RF unit is used.
- L. RF Unit Compartment [RF UNIT]. The RF Unit (optional) is inserted into this compartment.

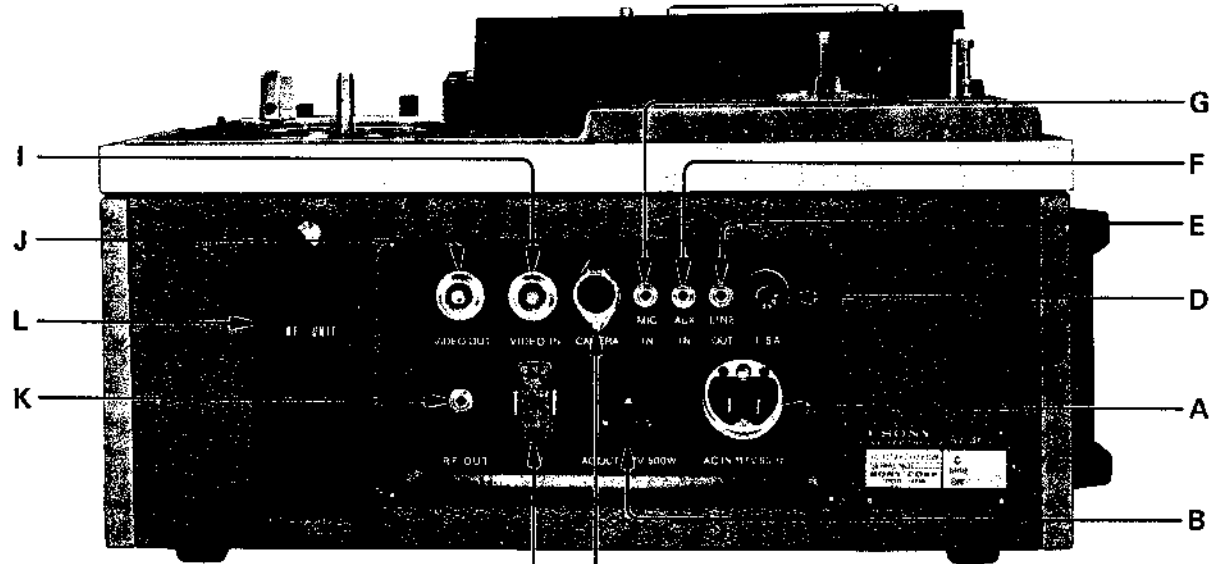
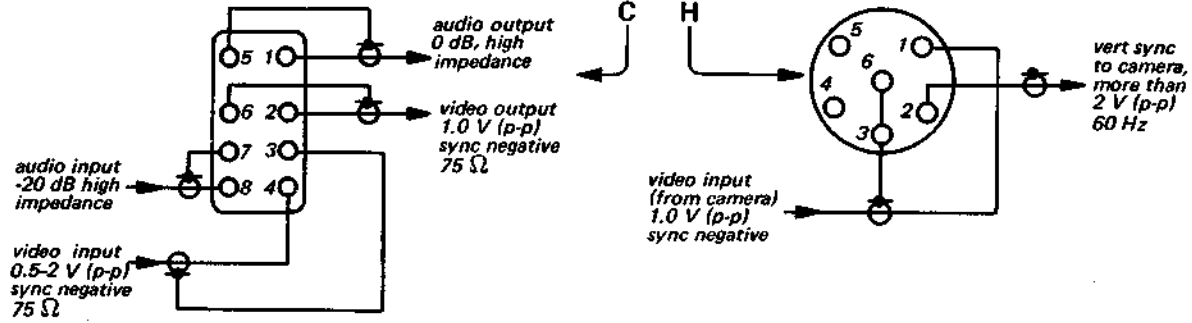

Fig. 1-2. Input/Output connections



SECTION 2

CIRCUIT DESCRIPTION

Refer to the block diagram on page 2-7 and the schematic diagram on page 9-15.

2-1. VIDEO CIRCUITS

Video information is recorded on the tape in the form of a frequency-modulated carrier. The video circuits on the V1 and V2 Boards process the video signal during record and playback operations.

In the record mode the video input is supplied to the V2 Board, where it is gain-controlled automatically, clamped, pre-emphasized, white-clipped, dark-clipped, fm modulated, and supplied to the record amplifier.

The video output signal from the record amplifier is supplied to the video heads through the slip rings and is recorded on the tape.

In the playback mode the recorded signals from the rotary heads are fed to the playback preamplifier on the V2 Board. The amplified video outputs are mixed together and these continuous fm signals are fed to the V1 Board.

The circuits located on the V1 Board include a limiter, differentiator, rectifier and demodulator. The video output from the V1 Board is a reproduction of the original video signal.

Video Input

PIN 4 of the TV (8-pin) jack for TV recording.

PIN 1 of the CAMERA (6-pin) jack for camera recording.

UHF connector for LINE (auxiliary) video input.

Video Amplifiers and AGC—Q101 to Q104

The incoming video signal is supplied to the first video amplifier Q102 through a pre-emphasis circuit consisting of R101 and C101. The input signal level for Q102 is controlled by AGC amplifier Q101 (FET), without manual video level control. Q102 and Q103 amplify the video signal and feed it to Q104. A sample of the video signal at the emitter of Q104 is fed to the peak detector consisting of C108, D101, and D102. The output of the rectifier is a positive dc voltage that is proportional to the peak white component of the video signal. This dc voltage controls the conduction of AGC amplifier Q101 and this controls the amount of input signal to Q102. R101 and C101 accomplish pre-emphasis so that the AGC circuit is effective for high frequency signals.

Low Pass Filter—L102, L103, C113

The low-pass filter rejects the video signals at the high end of the band, such as the 3.58 MHz color subcarrier and the 4.5 MHz audio i-f signal.

Deviation Setting and Clamp—Q105, R121, D103, R126

The output of the low pass filter is supplied to Q105 through R121.

R121 sets the video signal level to Q105 so that the following fm modulator produces an fm signal of 1.4 MHz deviation, from 3.2 MHz to 4.6 MHz. D103 clamps the sync tip of the composite video signal to the reference voltage picked off at the arm of R126. This reference voltage sets the sync tip (or no-signal) frequency of the fm modulator. R126 is set to establish the sync tip carrier frequency of 3.2 MHz.

Pre-emphasis and amplifiers—Q106, Q107, R130, R131, C118

The dc clamped video signal is applied through Q106 to the pre-emphasis circuit consisting of R130, R131, and C118 to improve the signal-to-noise ratio of the video information, and then to grounded-base amplifier Q107. Base-bias voltage for Q107 is supplied from the arm of R126.

White Clipper, Dark Clipper, and Mod. Driver—Q108, D104, R137, D107, R155

The pre-emphasized video signal contains overshoot in both the positive and negative directions. D104 limits the maximum positive signal (white peaks) of Q107 to the voltage picked off at the arm of R137. D107 clips negative spikes. Video from D104 is fed to the modulator through modulator driver Q108.

Modulator—Q109, Q110

The modulator is a free-running symmetrical multivibrator. Frequency control is achieved by returning both bases to the low-impedance source of modulating voltage—the emitter of Q108—through R140. Frequency varies from the tip-of-sync value of 3.2 MHz to a maximum 4.6 MHz for peak white signals. R148 and C122 are adjusted to obtain a symmetrical output waveform (equal pulse durations and slopes for each half cycle). Waveform symmetry is important as it determines

the extent to which carrier energy can be removed from the demodulated signal. The modulator output is approximately 4.0 V (p-p) at TP-106. The push-pull modulator output is converted to a single-ended feed by T101.

Record Amplifiers—Q210, Q211

The fm signals from the modulator is applied to record amplifiers Q210 and Q211. Q210 drives the video heads through driver transformer T203. The record amplifiers operate in the Record mode only, as B+ is switched off in all other modes. R225 adjusts the recording current applied to the video heads for optimum recording level. Video Heads A and B are connected in parallel to the secondary of transformer T203. R217 equalizes the recording current of Video Head B to that of Video Head A.

Video Heads

A slip-ring and brush assembly couples recording current to Video Heads A and B. The Video Heads supply signals during playback operations. The angle between the heads is $180^\circ \pm 20''$.

Playback Amplifiers—Q201, Q203, Q202, Q204

Outputs from the video heads are coupled through T201 and T202 (load ratio 1 : 1) to their respective playback amplifiers. The low-noise cascode amplifier Q201 (Q202, FETs) and Q203 (Q204) amplify the weak signals. A resonant circuit in the gate of Q201 (Q203), consisting of T201 (T202), R201 (R202), and C201 (C202), resonates with the reactance of the head and increases the output from the head at the resonant frequency to provide high frequency compensation for head-to-tape characteristics. Inductor L203 in the collector of Q203 (Q204) keeps the dc collector level constant, and also forms a trap with R205 to keep the audio bias/erase signal out of the playback amplifiers during audio dub operations.

Switchers and Mixer—Q205, Q206, Q207

The Channel A switching transistor, Q205, is employed in the source of Q201. Similarly, Channel B employs switching transistor Q206 in the source of Q202. The states of Q205 and Q206 are always opposite. For example, when Q205 is saturated, Q206 is cut off by the opposite-phase rectangular switching pulses from FF401 (hybrid IC). When Q205 is ON, the source of Q201 is shorted to ground, so that Q201 can amplify rf signals. Output from Head A is amplified by Q201 and Q203, and routed

to the following playback amplifiers during positive excursions of the switching waveform. While output of Video Head A is gated, the output of Video Head B is blocked from the playback amplifiers. This is done as follows:

When Q206 is cut off (Q205 ON), the cascode amplifier of Channel B can not amplify Head B output because of the high impedance (L202) in the source of Q202. The conditions described above are reversed with each 180° rotation of the head drum by the signals from two 30 PG coils mounted on the scanner. Thus, the output of each head is alternately coupled to Q207 and combined into a continuous rf signal without any noise. The timing relation of the switching pulses is shown in Fig. 2-1.

Equalizing amplifiers—Q208, Q209

The rf signal from Q207 is amplified by Q208 and fed to the limiters through Q209. The collector circuit of Q208 contains a resonant circuit consisting of R211, L204, and C211 which provides playback equalization. R211 and L204 set the resonant frequency to about 3.5 MHz for correct playback equalization.

Limiters—Q301 to Q305, D301 to D310

The limiter stages eliminate amplitude fluctuations caused by variations in head-to-tape contact. Limiting is accomplished by the four diode pairs with interstage amplification supplied by transistors Q301 to Q305. Each diode conducts when the signal across it reaches about 0.4 V (p-p) in the forward direction. Thus the signal is limited in both directions to 0.8 V (p-p). In the last stage D307/D308 (D309/D310) conduct when the signal exceeds 0.7 V (p-p) signal, so that 2.8 V (p-p) is developed across the combination D307 and D308 (D309 and D310). R305 in the base circuit of Q302 is adjusted for a correct operating point to produce a symmetrical limiter output waveform.

Demodulator—D311, D312, Q306, LPF

The input to the demodulator is differentiated by R324 and the primary winding of T301. The push-pull output of T301 is applied to a frequency doubler consisting of a pair of pulse detectors D311 and D312. They conduct on alternate half cycle to produce two positive output pulses per input cycle. Thus, carrier frequency is effectively doubled and placed outside the video passband. By integrating the pulse output in the low-pass filter that follows Q306, a video output is obtained that is proportional to pulse frequency. R326 is set to balance the pulse

output of the frequency doubler. R329 and C315 reduce high-frequency gain to provide de-emphasis.

Video Amplifiers—Q307 to Q310

Video output from the low-pass filter is amplified by Q307 and Q308 and then supplied to the video output stages (to Q309 for the rf adaptor and TV jack and to Q310 for VIDEO OUT.) R335 adjusts the video output level and is adjusted to provide 1.0 V (p-p) at the output terminals.

2-2. SERVO CIRCUITS

Basic principles of the servo and pulse system of the AV-3600 are shown in Fig. 2-1.

The rotational speed and angular position of the heads are controlled by means of a magnetic-brake servo system. In this system the head table is belt-driven at a speed greater than 30 rps by a synchronous motor. The servo system controls a magnetic brake that slows the head table to precisely 30 rps.

Each video head begins to scan the tape about 10 H (horizontal lines) before the vertical sync interval (rf signal) supplied to the video head and ends its scan about 10 H after the next vertical sync interval.

During TV record operations, separated 60-Hz sync signals serve as the timing reference for the servo. The arrival of every other 60-Hz sync pulse is compared with a 30-Hz pulse generated by 30 PG coil B in the Rotary-Head Drum Assembly. See Fig. 2-1. The comparator system of the servo controls brake current to maintain the correct time reference between the sync pulse and the 30 PG pulses.

In playback, the recorded control track pulses serve as the reference for the servo system.

Sync Separator and Pulse Amplifier—Q402, Q403

A sample of composite video signal from Q104 on the V2 Board is fed to Q402. Sync is separated from the composite video signal by Q402, and horizontal sync pulses are removed by the following integrator circuit (R424 through R426, C412 through C414). The separated vertical sync pulse is amplified by Q403 and then triggers monostable multivibrator MM402. During playback, Q401 amplifies control pulses from the recorded tape.

Frequency Divider—MM402, R433

A negative sync pulse from Q403, coupled through

D404, flips the monostable multivibrator MM402 (hybrid IC) into the unstable state. Pulse duration, determined by R433, is about 24 milliseconds, long enough for the circuit to ignore the next 60-Hz sync pulse. Thus the multivibrator runs at 30-Hz and is triggered by every other pulse. The 60-Hz sync pulse is fed to Pin 2 of MM402, and the divided 30-Hz pulse is obtained at the same Pin 2. Since the sync signal is referenced to the 30-Hz signal from 30 PG coil B, 60-Hz sync pulses must be halved.

Waveshaper—MM404, R441

During playback, the output from MM402 is supplied to monostable multivibrator MM404 via SW7-4 and D406, and triggers MM404 (hybrid IC). This multivibrator shapes the 30-Hz pulse from MM402 to form 30-Hz pulses with a 50% duty cycle so that a reference dc level may be obtained for the following gate circuit. R441 sets the duty cycle (pulse duration).

When the TRACKING control is ON (in playback) the output of MM403 triggers MM404.

Integrator and Gate—R446, C426, C427, Q405

The output from MM404 is integrated by R446 and C426 (or C427 in playback) to form the wave-shape shown at TP-410 of Fig. 2-1. The integrated pulse is fed to the gate circuit, Q405. The gate is turned on by the 30 PG pulse (from Q404) applied to its base. For the duration of 30 PG pulse, the integrated pulse applied to the emitter of Q405 is sampled and appears at the collector, and charges C432. Thus, the output of the gate is a function of the arrival time of the 30 PG pulse. The integrated pulse is gated on its leading edge by the 30 PG pulse as shown in TP-410 in Fig. 2-1. If the 30 PG pulse is early (servo too fast) the output of the gate is less. A late 30 PG pulse (servo too slow) results in greater output. During record the integrated 30-Hz pulse rises with a short time constant ($R446 \times C426$) as shown by the solid line in TP-410 in Fig. 2-1. Therefore, a slight deviation of the 30 PG pulse from its stable position on the 30-Hz integrated pulse ramp causes a large variation in gate output for the servo. This results in quick servo response, and also minimizes the variation of control track signals recorded on the tape.

In playback, the integrated 30-Hz pulse rises with a faster time constant ($R446 \times C427$) as shown by the dotted line in TP-410 in Fig. 2-1. A deviation of 30 PG pulses (from control track signals on the tape) on the ramp causes less of a variation in the gate output resulting in a slower servo response compared

with that in record and absorbs control track signal deviations caused by wow and flutter.

30 PG Coils A and B

Two PG coils are mounted on the scanner (upper drum) 180° apart. 30 PG coil A is at the front of the scanner and 30 PG coil B at the rear. Both PG coils are connected between B + and ground through R401 and R402 respectively, and biased at about 2 V dc. Their fields are cut once per revolution by a single vane (pole piece) mounted on the rotating head platform. Each 30 PG coil produces a pulse shown in Fig. 2-1.

Switching Pulse Former and 30 PG Pulse Shaper—FF401

Negative going pulses of the two 30 PG coils are coupled to bistable multivibrator FF401 (hybrid IC) through D401 and D402. A pulse supplied to Pin 1 flips FF401 and a pulse supplied to Pin 4 flips it back. The outputs from Pins 2 and 3, identical 30-Hz square waves opposite in phase, are applied to switchers Q205 and Q206 through integrators R406/C205 and R407/C206, respectively. A sample of the output from Pin 2 is supplied to a differentiator consisting of R408 and C404. The negative spike from the differentiator, which is in phase with the pulse generated by 30 PG coil B, triggers MM401 to supply the gate circuit.

30 PG Delay Multivibrator—MM401, R412, R413

Monostable multivibrator MM401 (hybrid IC) delays the 30 PG pulse (from 30 PG coil B) and sets the timing interval between the vertical sync signal (during record) and the 30 PG pulse from coil B. Since the sync signal serves as the timing reference, the time delay advances the angular position of the rotating-head platform with respect to the video signal. MM401 produces a positive pulse of 930 μ s duration during record and one of 1.9 msec duration during playback for each input pulse. This output pulse is differentiated by C428 and R448 and the negative spike, delayed by an amount equal to the pulse duration of MM401, is supplied to the gate circuit. The pulse duration, i.e. the delay time of MM401, is selected by SW7-8 according to the mode of operation. Thus, the differentiated pulse is able to gate the integrated reference 30-Hz pulse at the proper position on the ramp to produce the same gating output in record or playback regardless of the difference in 30-Hz pulse waveshapes. See Fig. 2-1. R412 and R413 adjust the pulse duration (delay

time) of MM401 in record and playback operations respectively.

Delayed 30 PG Pulse Shaper

The delayed 30 PG negative pulse is amplified and shaped by Q404. Output of Q404 feeds the gate circuit.

Dc Holder and Amplifiers—C432, Q406, Q407, R451, R454

Gate output appears across C432, which holds the level until the following gate output. C432 sets the gate-to-source voltage of Q406 and thus establishes Q406 output. Direct coupled dc amplifiers Q406 and Q407 supply control current to the servo brake coil. R451 sets the response time of the servo system by controlling the amount of feedback current from Q407 to Q406 and is adjusted for minimum response time without servo hunting. A large amount of feedback reduces the ac gain of the amplifiers and prevents servo hunting but it increases the response time. R454 adjusts the dc gain of Q406 to obtain optimum braking current.

Control Track Head—CTL Head

During record, an output from monostable multivibrator MM404 is applied to the Control-Track Head (CTL Head). This records a 30-Hz timing reference to be used during playback in place of the vertical sync pulse.

Control Track Pulse Amplifier—Q401

In playback, control track pulses picked up by the CTL head are amplified by Q401 and coupled to Q402 through a noise filter consisting of R418, C409, and C410.

Tracking Control Multivibrator—MM403

When the TRACKING control (R007) on the Control Panel is pulled out during playback, the 30-Hz pulse from MM402 is coupled to MM404 via the tracking multivibrator, MM403 (hybrid IC). Monostable multivibrator MM403 compensates for (a) variations in control track information between recorders, (b) tape stretching, and (c) tolerances in physical placement of the CTL head. For this purpose, MM403 delays the control track pulse and adjusts the timing interval between the video information and the recorded control track pulse. The delay time can be varied with the TRACKING control R007, which varies the pulse duration of MM403.

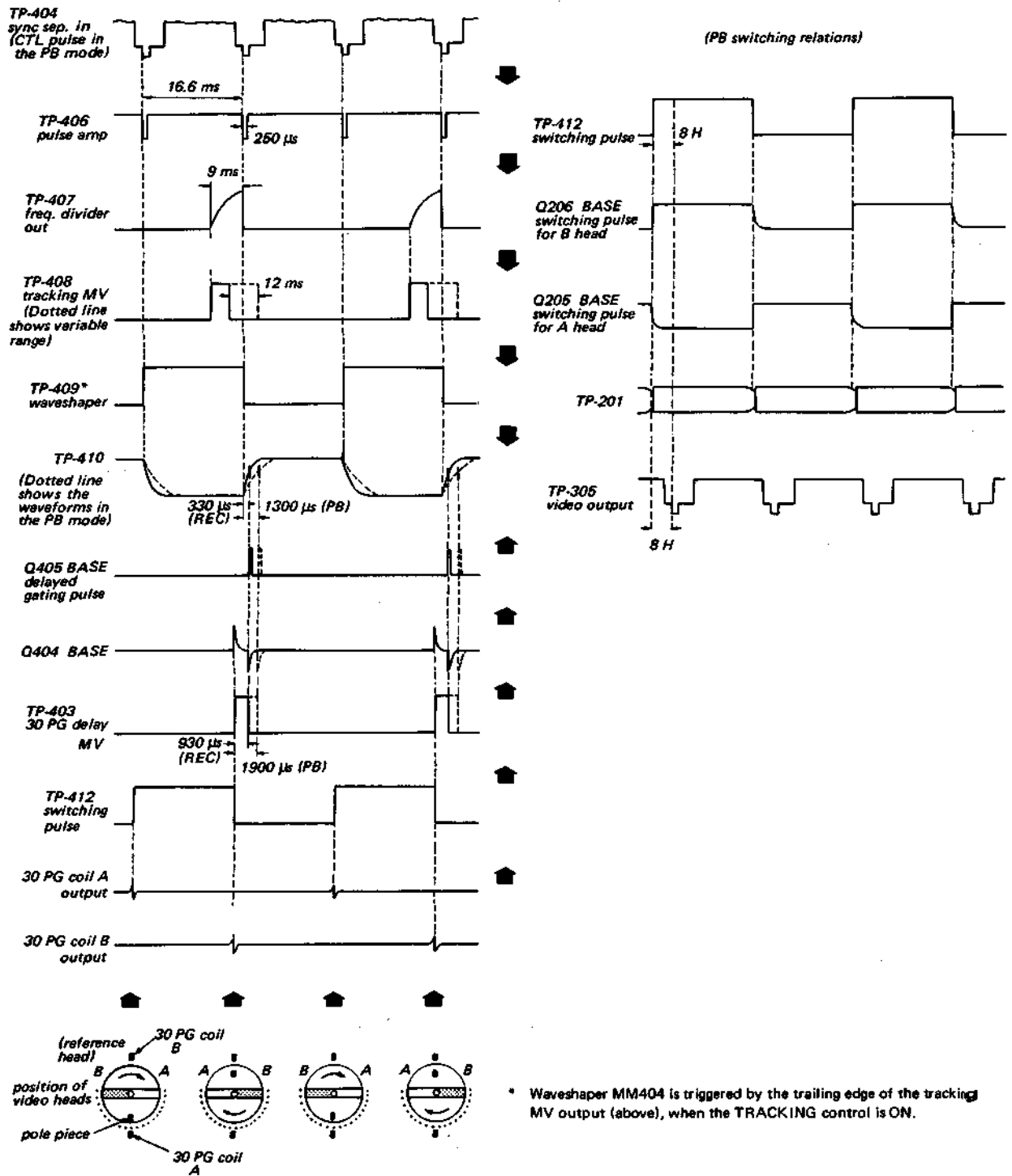

Fig. 2-1. Timing relations of pulse and servo system. (waveforms are not drawn to scale)

2-3. AUDIO CIRCUITS

Record

Audio input feeds through C501 to preamplifiers Q501 and Q502. The gain of Q502 is automatically controlled by AGC amplifier Q503 (FET). R510 and C506 provide negative feedback. Output of Q502 is applied to the driver amplifier Q504 and then to the audio output stage Q505. A sample of the output is fed to the audio level detector consisting of C528, C535, D501 and D502. The output dc voltage of the detector controls the conduction of AGC amplifier Q503. Thus Q503, in the feedback loop from the output stage Q505 to the input Q501, controls the amount of feedback current and the gain of Q501. R521 in the source of Q503 adjusts the audio output level.

Output from Q505 is applied to the audio record/play head. In addition, rf bias produced by the bias/erase oscillator Q506 is applied to the head through trimmer capacitor C532. This adjusts the bias signal level supplied to the head. Bias trap L502 and C525 eliminates the high-frequency bias signal from the audio output circuit. L501 and C512 in the base of Q504 and L503 and C519 in the collector of Q505 provide pre-emphasis.

Playback

In playback, the feedback network in the pre-amplifier is altered to take the path through R513, R514, and C510. This network changes preamplifier characteristics to provide de-emphasis and equalization. Preamplifier output appears across R515, which sets the drive to the output stage for playback. The driver and output stages, Q504 and Q505, function in the same way for both record and playback. The bias/erase oscillator Q506 is not energized as B + to this stage is switched off in playback.

2-4. CAMERA CONTROL CIRCUITS

The sync pulse former on the SY3 Board shapes the 60-Hz ac sine wave into vertical sync pulses to lock the horizontal deflection oscillator in the camera. The sine wave signal from the secondary winding of T001 is supplied to C902. Negative peaks are clamped to ground by D901 and C902. The clamped signal is amplified by Q901, differentiated by R905 and C904, and supplied to the pulse amplifiers Q902 and Q903. Q903 feeds negative vertical sync pulses through the CAMERA connector CN4 to the camera.

2-5. POWER SUPPLY CIRCUITS

The ac line voltage is stepped down by the power transformer T001 and supplied to full wave rectifiers D601 and D602. Dc output from the rectifiers is filtered by C601 and applied to the series regulator Q601. Transistor Q603 compares a sample of the output voltage, picked off at R604, with a reference voltage supplied by Zener diode D603. A change in output voltage, detected by Q603, results in a change in conduction of Q602 and Q601 that offsets the original voltage shift.

B+ for the RF adaptor is fed through a simple regulator consisting of R005 and D001.

Sets bearing Serial Number 12,201 and higher have a extra regulator for the rf adaptor consisting of Q604 and Q605 on an R2 board. This regulator operates the same way as the main regulator.

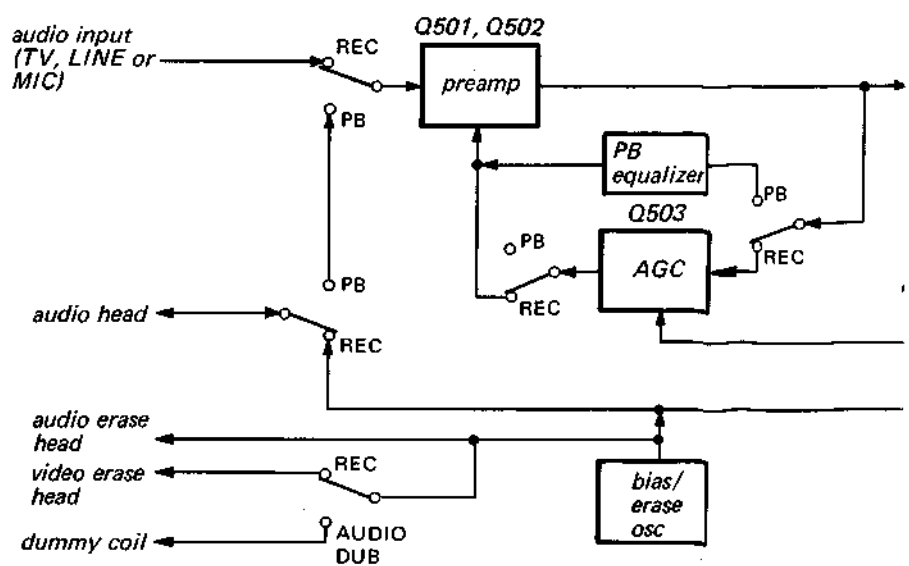
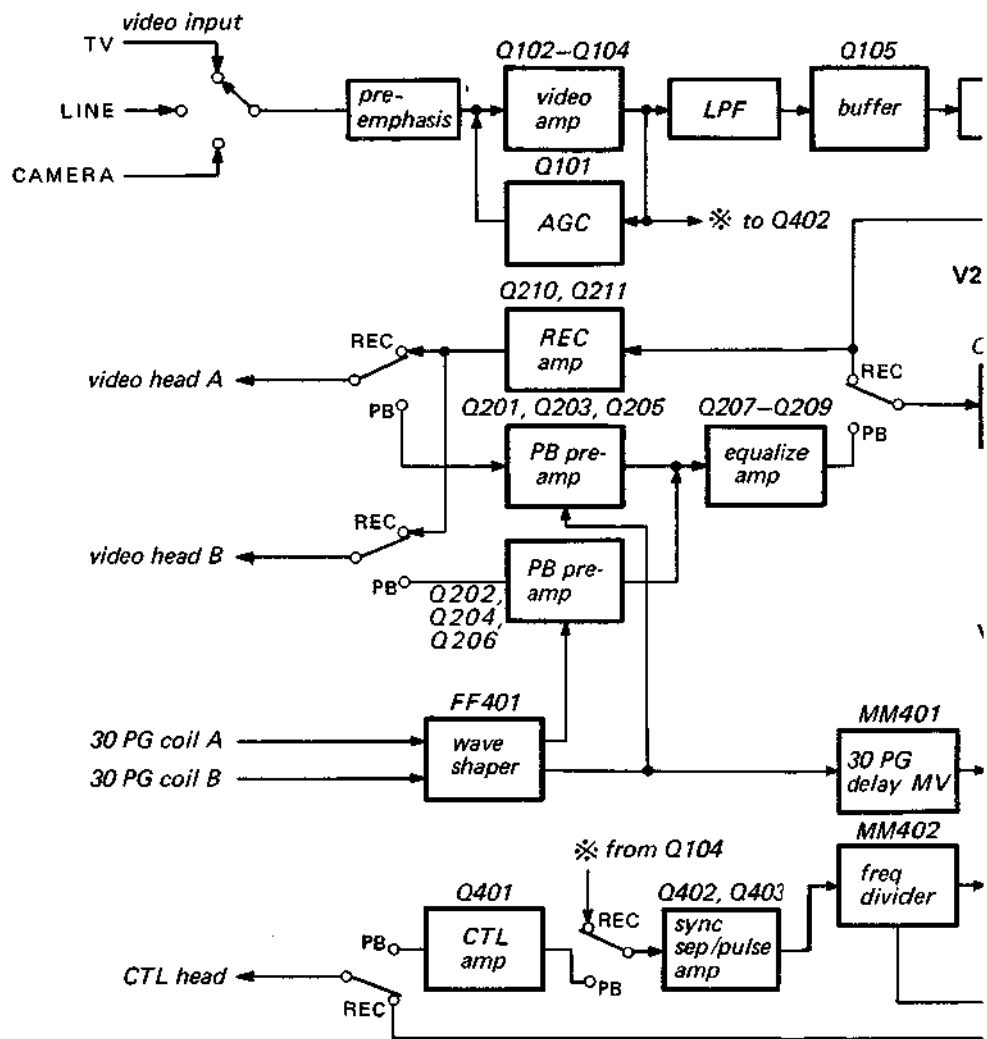

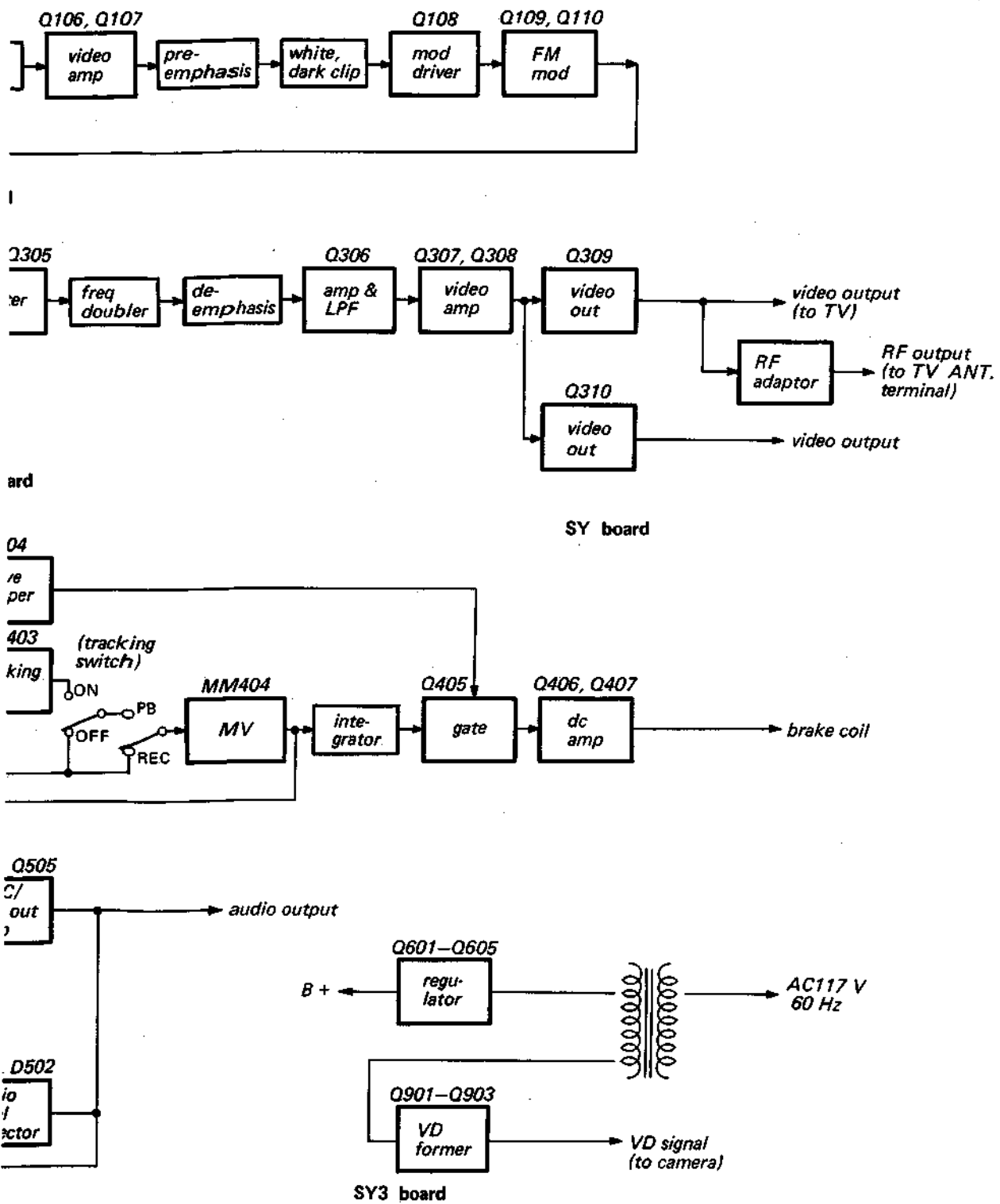

Fig. 2-2. System block diagram

SECTION 3 DISASSEMBLY

3-1. CABINET REMOVAL

1. Turn the VTR (with cabinet lid) upside down on a padded bench as shown in Fig. 3-1.

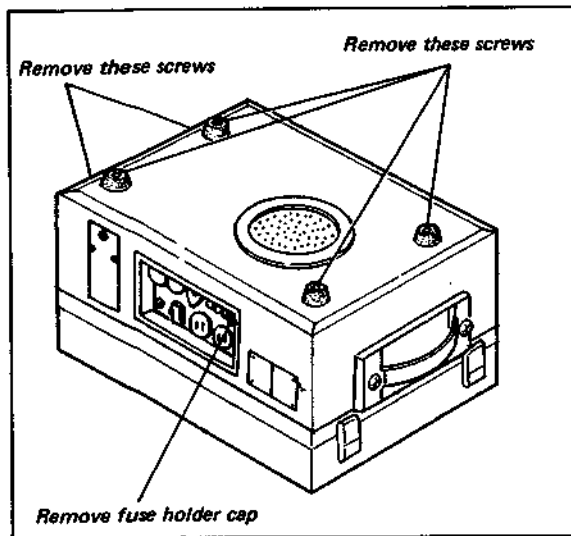

Fig. 3-1. Cabinet removal

2. Remove the four Phillips-head screws from the bottom of the cabinet as shown in Fig. 3-1. Also, remove the two Phillips head screws on the side of the cabinet.
3. Remove the fuse holder cap (and fuse) on the connector panel.
4. Lift off the cabinet.

3-2. REMOVAL OF CONTROL AND REEL PANELS

1. Pull out the SKEW control and the TRACKING control knobs.
2. Loosen the two screws at the back of the Head Cover. It is not necessary to remove these screws completely. Lift off the Head Cover.
3. Loosen the set screw in the Function Lever (Allen wrench, 0.1" across the flats). Pull off the lever.
4. Remove the screw securing the Pinch Roller Retainer. Remove the Pinch Roller. Be careful not to lose the Pinch Roller Spacer.
5. Loosen the two screws "A"* and remove the four screws "B" as shown in Fig. 3-2.
6. Lift off the Control and Reel Panels.

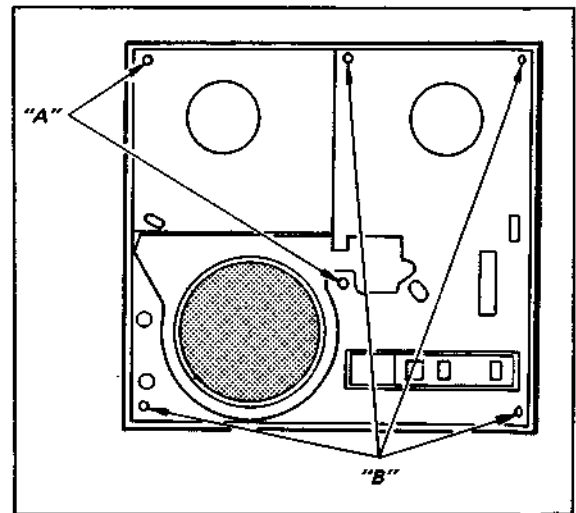

Fig. 3-2. Removal of Control and Reel Panel

*These are captive screws and need not be removed completely.

SECTION 4

MECHANICAL MAINTENANCE

4-1. PRECAUTIONS

Machine compatibility (interchangeability of tapes between machines) depends upon very close mechanical tolerances in the tape path. The tape path is factory-adjusted and should not require realignment under normal circumstances. Do not attempt adjustment of the tape guides or the tapered guides. If mechanical damage requires replacement and/or adjustment of the guides in the tape path, return the unit to a SONY FACTORY SERVICE CENTER for repair.

4-2. CLEANING HEADS AND SLIP RINGS

Noise in the picture during playback is usually caused by an accumulation of debris in the video heads. In some cases, half the picture may be noisy (split screen); in severe cases, video output may be lost.

To clean the heads, stop the machine, remove the tape and move one of the heads to the cleaning position near the left tapered guide. See Fig. 4-1.

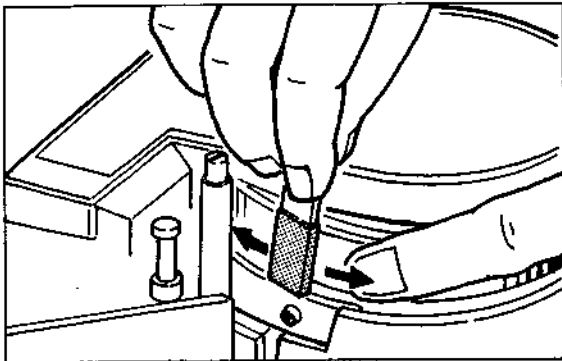

Fig. 4-1. Video head placed at the cleaning position

CAUTION

NEVER TRY TO CLEAN THE HEADS WITH THE MOTOR RUNNING

Saturate a cleaning tip with SONY cleaning fluid or methanol. (Spray cleaner, such as M/S-brand magnetic head cleaner, gives excellent results.) Rub the

cleaning tip across the head tip from side to side. Avoid vertical motion, which might damage the video head.

Clean the erase and audio/control heads with SONY cleaning fluid, if necessary. Move the cleaning tip vertically across that part of the head surface that normally contacts the tape.

Noisy slip rings cause intermittent dark horizontal lines in the playback picture. To clean the slip rings, remove the upper drum cover on the top of the rotary-head drum assembly. Remove the tape from the tape path. Apply a few drops of SONY cleaning fluid to the slip rings. Turn on the motor for 10 to 20 seconds. Carefully wipe excess fluid from the tape path around the rotary head drum assembly.

If slip-ring noise persists, clean the slip rings directly with a head-cleaning tip saturated with SONY cleaning fluid. Rotate the head assembly by hand to avoid contacting the brushes.

4-3. LUBRICATION

Five major lubrication points are:

1. Supply-Reel Table Bearing.
2. Take-Up Reel Table Bearing.
3. Capstan Bearing.
4. Take-Up Reel Idler Bearing.
5. Pinch Roller Bearing.

To lubricate the reel table bearings, remove the screw and washer at the top of the spindle. Lift the reel table slightly so that the hollow shaft of the table rises above the spindle. Apply one or two drops of SONY oil, OL-1K, to the inner surface of the reel table shaft. Seat the reel table in its proper position and replace the screw and washers.

To lubricate the Capstan Bearing, pull up the Capstan by hand, and apply a few drops of oil to the Oil Ring of the Capstan Bearing. See Fig. 4-2. Be careful not to get oil on the surface of the Pinch Roller. Wipe off excess oil.

Note: Capstan Bearing lubrication is important. Oil as directed every 200 operating hours.

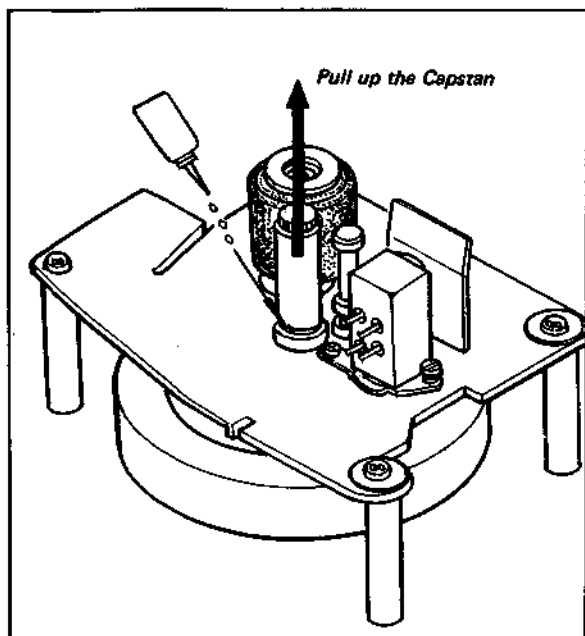

Fig. 4-2. Lubrication of capstan bearing

To lubricate the Take-Up Reel Idler, remove the Tape-Up Idler Cap. Apply a drop of oil to the shaft of the idler. Wipe away excess oil from the rubber driving surfaces.

Note: A lack of oil on this part sometimes causes bearing noise in Play and Fast-Forward modes.

To lubricate the Pinch Roller Bearing, remove the pinch roller retainer. Apply a few drops of oil directly to the pinch roller oil ring.

Sliding Parts. All sliding parts of the tape-transport mechanism are lubricated with grease which, in normal use, need not be replenished. However, if new parts are installed or lubrication is obviously needed, apply a high-temperature grease at points of contact. Avoid excessive lubrication.

4-4. DRIVE-BELT REPLACEMENT

A worn or stretched drum drive belt results in excessive slippage and loss of servo control.

Check the belt by inspecting the inner (bearing) surface. Look for cracks and streaks along the long dimension of the belt. Replace the belt if it is badly scored along its length. To check belt length, remove the belt from the machine and compare its total length (flattened) with that of a new belt from stock. Replace the belt if it is 1/4-inch or more longer

than a new belt.

To install the video-drum belt, stand the VTR on its left side. Loop the belt over the motor pulley, with the shiny side of the belt inside (against the pulley). Grasp the bottom of the loop, turn it one-half turn clockwise, and wrap around the pulley of the rotary head drum assembly. See Fig. 4-3.

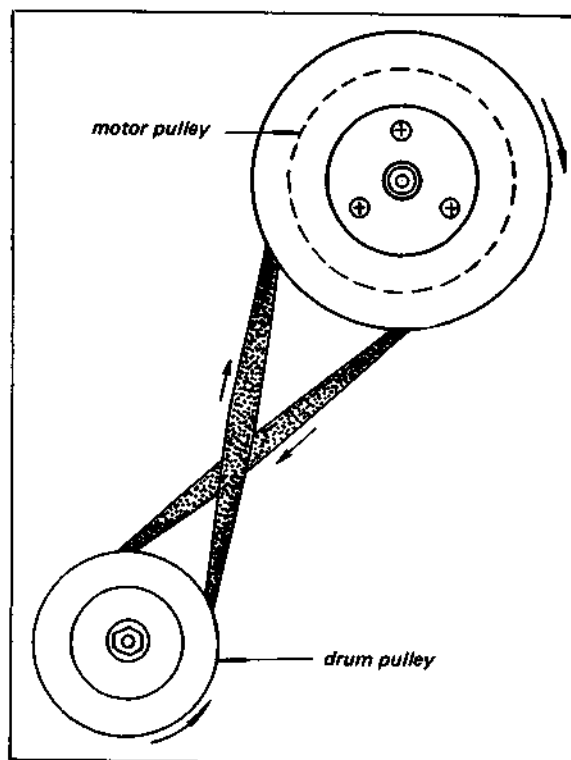

Fig. 4-3. Drive belt installation

4-5. DRIVE PULLEY ADJUSTMENT

The lower motor pulley requires adjustment if the head-drum drive belt slips off the pulley or rides against the upper or lower shoulder of the pulley. Adjust the pulley as follows. Remove the drive belt. Loosen the set screw on the motor pulley and adjust its height by eye until it is parallel to the pulley on the rotary-head drum assembly. Reinstall the belt. (See Section 4-4). Place the VTR in the normal horizontal position. Thread and play the tape. Observe the position of the belt on the pulleys. Stop the machine and readjust pulley position to make the belt run in the center of the pulleys.

Check final pulley position by starting and stopping the tape several times. Rewind the tape and try the fast-forward mode a few times. Make sure that the belt does not drift towards the edge of the pulley or slip off when changing speeds.

4.6. VIDEO HEAD REPLACEMENT

Video Head Replacement is required when the heads are damaged or have open coils. In addition, insufficient tape penetration, resulting from head wear after long periods of operation may necessitate replacement. To remove and replace the rotary head assembly (the beam on which the two video heads and the slip-rings are mounted), proceed as follows.

CAUTION

The video head assembly and the surrounding machined parts are very precisely made. Use utmost care when performing any work on the rotary head-drum assembly.

Removal

1. Turn off the power. Loosen the screws that hold the head-drum cover. A coin will serve as a screwdriver for these screws. Loosen only half a turn; do not try to back the screws all the way out. Lift off the head-drum cover.
2. Remove the two Phillips-head screws that hold down the cover plate. Loosen the brush pressure adjusting screws and remove the brush from the spring as shown in Fig. 4-4.
3. Remove the two upper 5 x 20 Hex-Head Bolts and washers with a 4 mm Allen wrench. Hold the upper drum with one hand so that it does not fall as you withdraw the two screws.
4. Carefully lift the top of the drum assembly and fold it back. Place the drum top carefully on the reel panel. See Fig. 4-5.

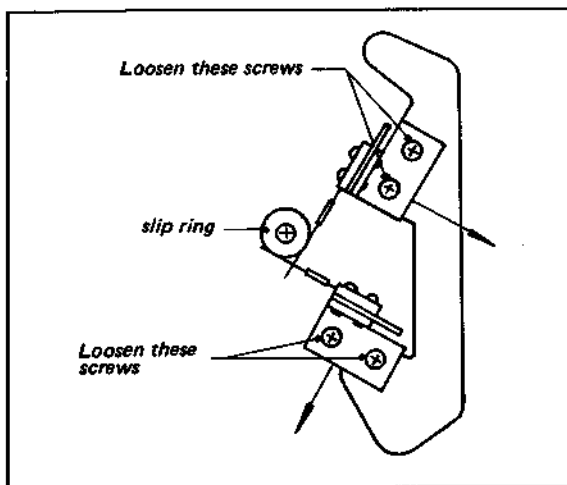

Fig. 4-4. Preparation for video head replacement

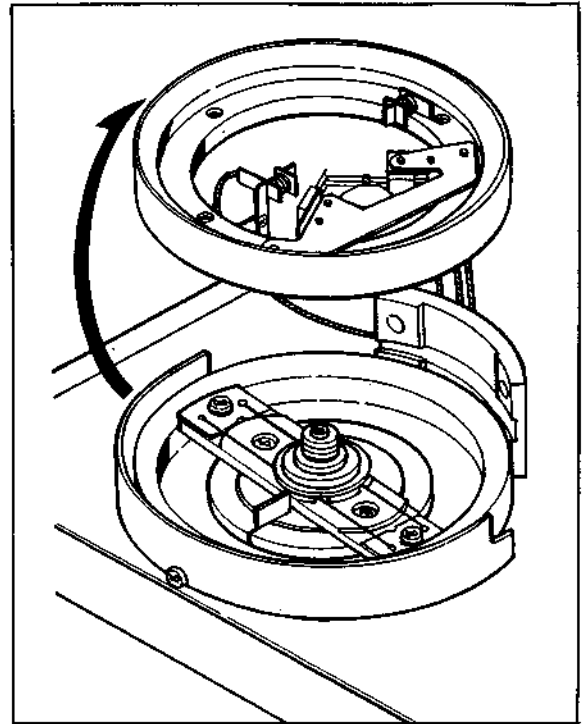

Fig. 4-5. Video head assembly removal

CAUTION

Do not touch the PG pole pieces.

Position the rotary head platform by turning the aluminum beam on which the heads are mounted. Slight pressure on the pole pieces can affect pole piece alignment.

5. Hold the Video Head Assembly to keep the platform from rotating and loosen the two P 4x8 screws that hold the head assembly to the platform. Do not exert too much downward pressure on these screws; loosen the locking compound with Methyl Ethyl Ketone. Remove the screws and the washers.
6. Using both hands, carefully lift the Video Head Assembly off the platform.

Replacement

7. Clean the bottom of the new Video Head Assembly. Do not scratch or remove the spacer on the bottom of the Video Head Assembly.
8. Position the platform so that the 30 PG pole piece is at the 12 o'clock position.
9. Carefully place the Video Head Assembly on the platform with the B head (identified by the red paint) to your left (9 o'clock position). See

Fig. 4-6. The head assembly should fit down snugly against the platform without using force.

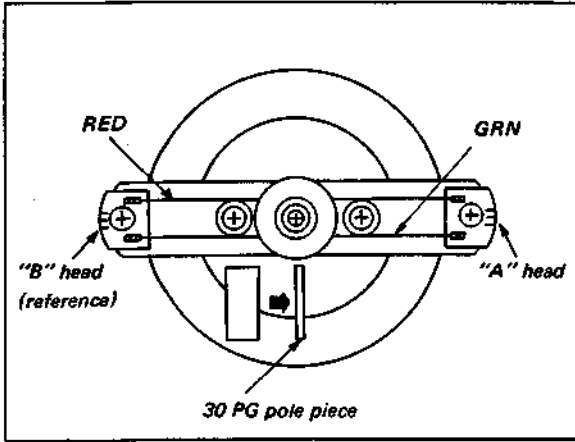

Fig. 4-6. Position of the head assembly

10. Install the two P 4 x 8 screws and washers. Rotate the head assembly gently to the left and right until it is approximately in the center of the angular "play" permitted by the mounting screws. Tighten the screws alternately, applying torque gradually until the screws are tight.

11. Carefully swing the top of the Rotary Head Drum Assembly back into place, support the top with one hand while inserting the two Hex-Head bolts and washers. Do not tighten the screws all the way.

12. Grasp the top of the Rotary Head Drum Assembly and push it back and down against the drum holder so that top surface of the upper drum is even with that of the drum holder.

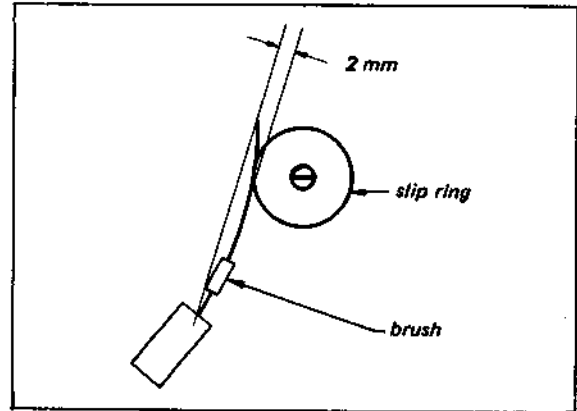

Fig. 4-7a. Brush pressure adjustment

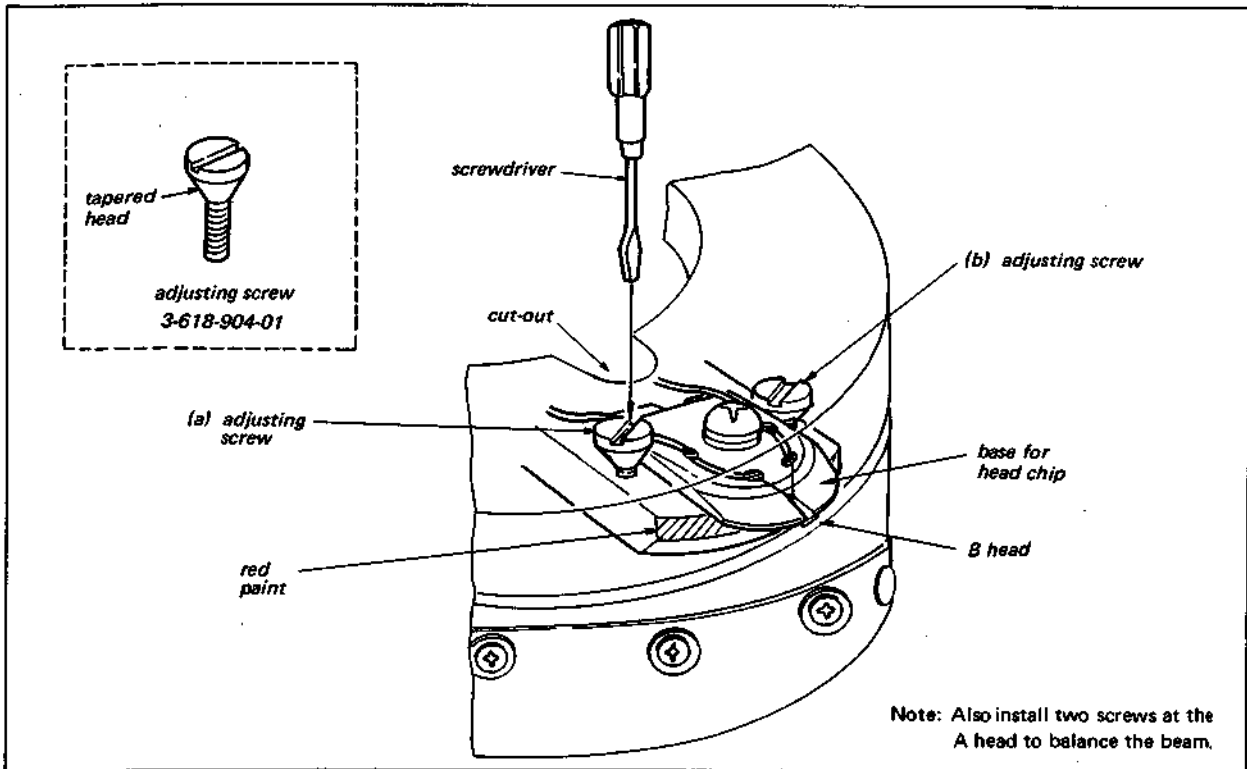

Fig. 4-7b. Video head dihedral adjustment

13. Tighten the two bolts alternately, applying torque gradually until all are tight.
14. Tighten the brush pressure adjusting screws to obtain a 2 mm bend (approximately) as shown in Fig. 4-7a. Inspect the brush and slip-ring assembly to make sure that the brushes are centered in the slip rings.

Video Head Dihedral Adjustment

Normally, if the video heads have been replaced according to the foregoing procedure, dihedral need not be adjusted. If the dihedral setting has been disturbed, however, or readjustment is otherwise indicated, proceed as follows.

The two video heads should be displaced exactly 180° apart measured at the head gap. If they are not, tape interchangeability can not be maintained. Video Head B (not A) should be adjusted so that it is correctly aligned with respect to Video Head A.

This adjustment requires the use of the SONY Alignment Tape and the four adjusting screws shown in Fig. 4-7b. The adjusting screw has a tapered head which bears against the base of the head when turned clockwise, thus forcing the head to move laterally. The thread of this screw is different from that of any other conventional screw.

CAUTION

Do not use conventional screws for the dihedral adjustment as damage to the thread in the head beam will result. Adjusting screws for the video head are available for all AV-Series Videocorders.

Proceed as follows:

1. Thread a SONY Alignment Tape onto the Videocorder.
2. Play back the tape with a monitor connected.

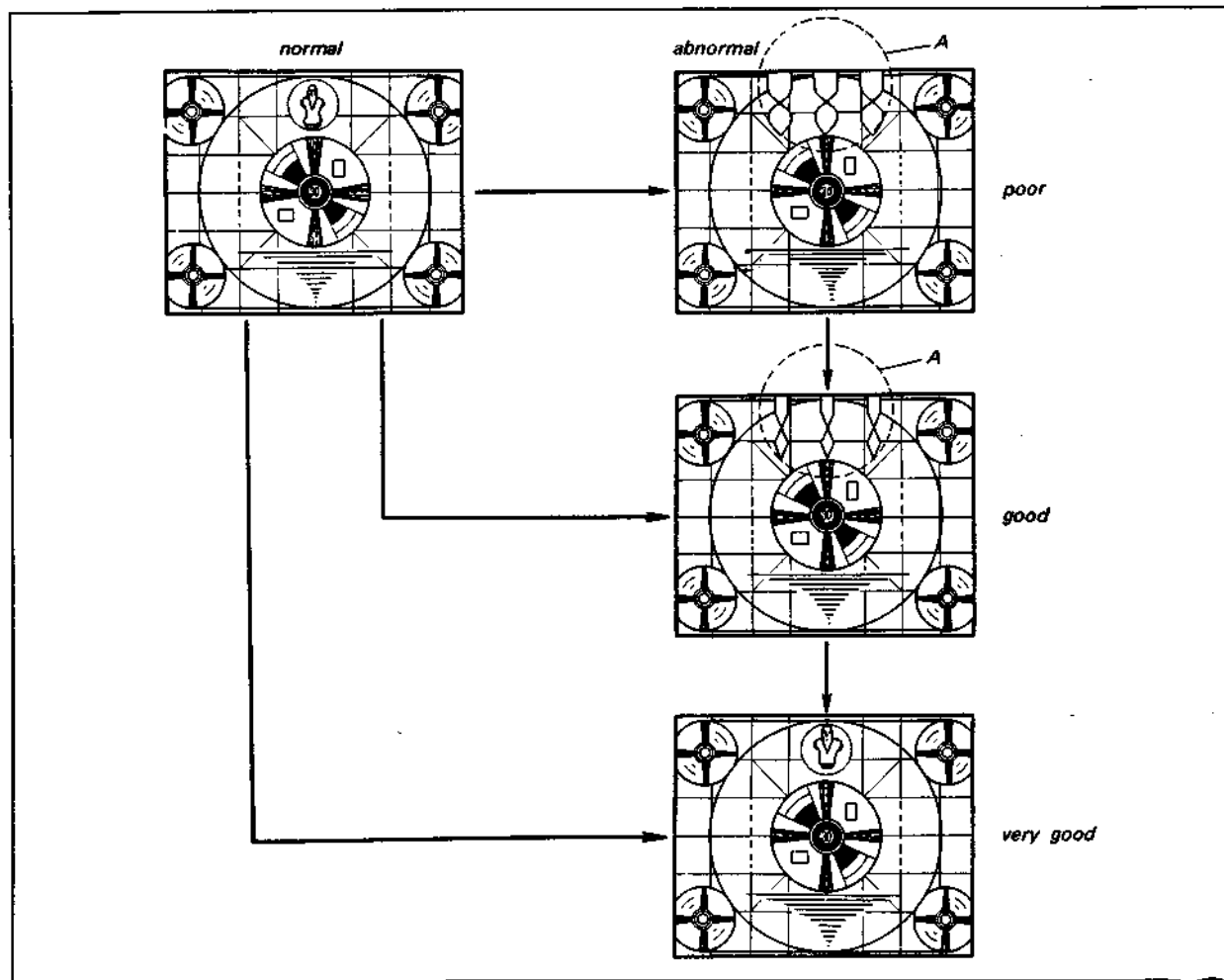

Fig. 4-7c. Picture detail for dihedral adjustment

3. Observe the picture on the monitor. (DO NOT USE A MONITOR SET FOR A SHORT HORIZONTAL AFC TIME CONSTANT.)
If the top of the picture is as shown by "A" in Fig. 4-7c (it appears as horizontal jitter), adjust Video Head B as follows.
4. Stop the Videocorder and remove the tape.
5. Position the B head so that the threaded adjusting-screw holes are accessible through the cut-out in the upper head drum. See Fig. 4-7b.
6. Install the adjusting screws into the threaded holes at either side of the head base until the tapered part just touches the head base.
7. Similarly, install adjusting screws into the two threaded holes at either side of the A head. These two screws serve only as weights to counter-balance the head-mounting beam.
8. Play back the tape and observe the top of the picture shown at "A" in Fig. 4-7c.
9. Stop the Videocorder. Position Video Head B (identified by red paint on the outer edge of the beam) to the adjusting position shown in Step 5.
10. First, loosen the (a) adjusting screw about a quarter turn counterclockwise and tighten the (b) adjusting screw a quarter turn clockwise. See Fig. 4-7b.
11. Play back the tape. Check the picture on the monitor screen.
12. If the dihedral error does not change, repeat Steps 9, 10, and 11 until a change is visible.
13. If the dihedral error decreases, repeat Steps 9, 10, and 11 until a normal picture is obtained.
14. If the dihedral error increases, reverse the direction of rotation of the adjusting screws and repeat Steps 9 to 12 until the distortion in the picture is minimized.
15. Thread a blank tape and make a recording using a video camera focused on a test pattern (or using a telecast test pattern).
16. Check the dihedral error in the picture and trim up the position of Video Head B as described in Steps 9 to 14.
18. Remove the four adjusting screws from the head assembly.

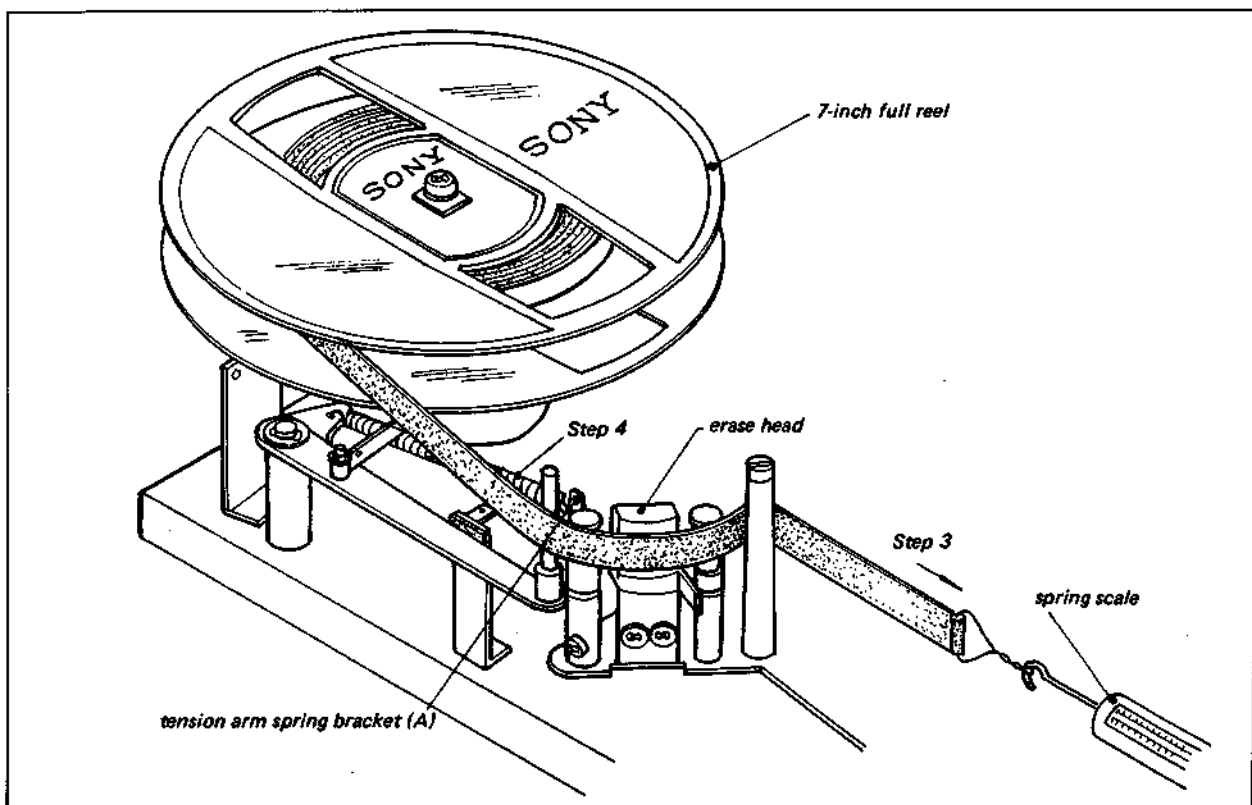

Fig. 4-8. Tape tension check

4.7. TAPE TENSION BRAKE CHECK

This adjustment corrects the back tension applied by the Tension-Brake Servo to the Supply Reel.

1. Place a full reel of tape on the Supply-Reel Table. Set the Function Lever to the FORWARD position. Set the SKEW Lever in the middle position.
2. Make a loop in the tape and attach a spring scale as shown in Fig. 4-8.
3. Pull the scale in the direction indicated — a steady pull at approximately the correct tape speed should give a reading of 30 to 45 grams.
4. If not, remove the Reel Panel and adjust the position of spring bracket (A) to obtain a correct reading. See Fig. 4-8.
5. Repeat the tension check using a supply reel with a few turns of tape on it. It should yield a reading of 65 grams or less. If it does not, proceed to Steps 6 through 10 and then repeat Steps 1 to 3.
6. Set the Function Lever to the FORWARD position.
7. Check the distance between the Tape Guide Pin on the Tension Arm and the extreme left edge of the drum deck as shown in Fig. 4-9. It should be about 1 mm. Swing the Brake Band as needed to obtain the correct spacing.
8. Check for clearance between the hole in the chassis and Item ① shown in Fig. 4-9. If the correct clearance cannot be obtained, bend Part A with a pair of pliers to obtain the gap. (Don't bend it too much.)
9. Check the distance between the rod and the Tension Arm as shown in Fig. 4-9. It should be 2 mm. Bend the end of rod as needed to obtain the correct spacing.
10. Set the Function Lever to the STOP position. Check the position of the Tape Guide Pin shown in Fig. 4-9. Reposition the Tension Arm Spring Bracket to obtain the correct position.

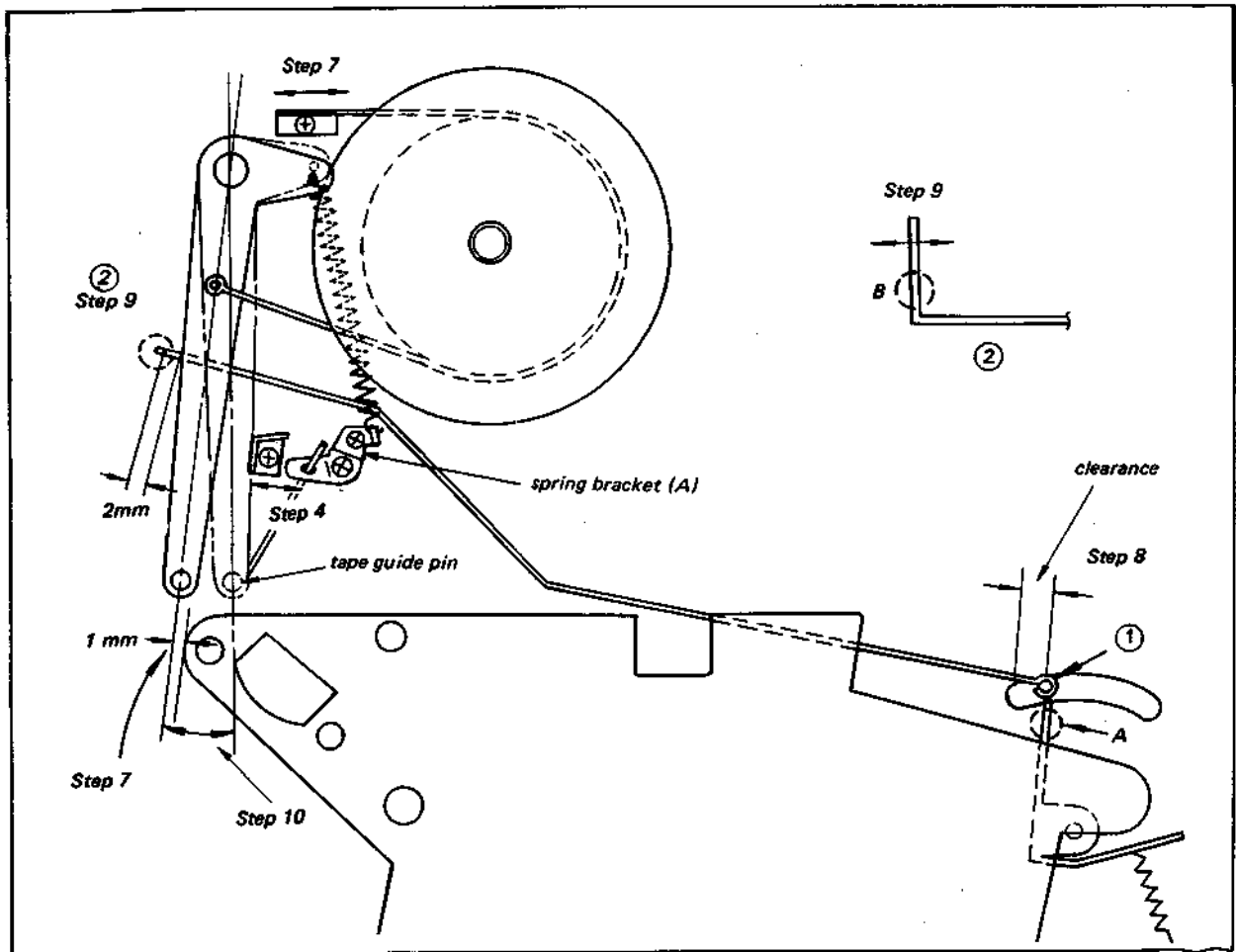

Fig. 4-9. Tension arm adjustment

4-8. REEL TABLE HEIGHT

1. Run a tape in the FORWARD mode.
2. Check both reels to see that tape does not rub against the edges of the reels.
3. If the tape is not centered in either reel, adjust reel height by adding or removing the fiber washers (Thrust Bearing Washers, Part Number 3-601-037-01) beneath the Reel-Table Assembly.

4-9. AUDIO/CONTROL HEAD REPLACEMENT

A malfunctioning Audio/Control Head can be replaced without disturbing servo tracking by the following procedure.

1. Unsolder the leads at the rear of the Audio/Control Head.
2. Remove the screws labelled A and B in Fig. 4-10 (a). Be careful not to lose the spring on the left screw (A). Do not loosen the screws in the long slots.
3. Lift the head assembly off the mounting plate.
4. Turn the head upside down and remove the two screws that hold the head assembly to the mounting plate.
5. Place the new head assembly on the mounting plate and install the two screws from the bottom.
6. Install the Head Mounting Plate Assembly using

the original screws A and B in Fig. 4-10(a). The spring on screw A goes between the head of the screw and the top of the mounting plate. Tighten screw A and adjust screw B (azimuth adjust) as follows.

7. Thread the SONY Alignment Tape and play the first section (Test Pattern). Connect an AC VTVM to the LINE OUT connector on the Connector Panel and terminate this connector with a 100 k Ω resistor. Adjust the azimuth screw (Screw B in Fig. 4-10 (a) for maximum indication on the VTVM (maximum output at 7 kHz).
8. Play the tape and check that the core of the head extends an equal amount above and below the edges of the tape. See Fig. 4-10 (b). Adjust the tilt screw at the rear of the mounting assembly, if necessary, until this condition is achieved.
9. Recheck the azimuth adjustment.
10. Check audio bias voltage. See Section 7-5.

4-10. TAKE-UP IDLER ADJUSTMENT

Capstan Motor Pulley Height Check

1. Make sure the Capstan Belt is clear of the Pause Brake Push Rod by 0.5 to 1 mm. See Fig. 4-11.
2. Check that the Capstan Motor Pulley is clear of the Take-Up Idler by more than 1 mm. See Fig. 4-11.

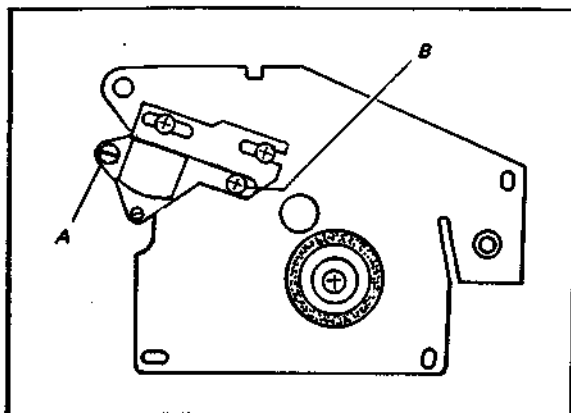

(a)

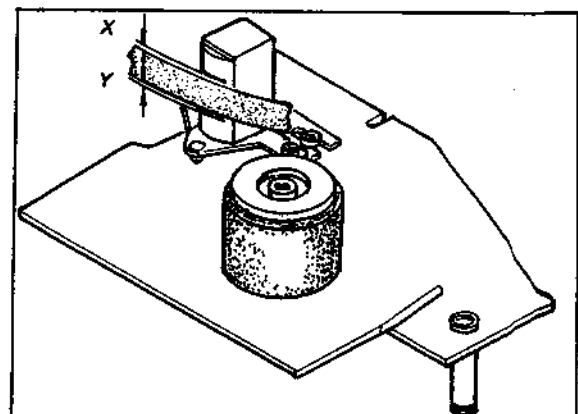

(b)

Fig. 4-10. Audio/Control head replacement and adjustment

3. Adjust the height of the Capstan Motor Pulley, if necessary.

Take-Up Idler Height (Fast Forward Mode)

1. Set the Function Lever to the FAST FORWARD position. The Take-Up Idler is lifted by the Take-Up Cam. Make sure that the lower surfaces of the Take-Up Idler and the Take-Up Reel Table (lower) are in line or that the lower surface of the Take-Up Idler is slightly higher.
2. If this condition does not exist, place the Function Lever in the FORWARD position. Bend Finger A with a pair of pliers as shown in Fig. 4-12 to obtain the correct Take-up Idler height.

4-11. REWIND IDLER REPLACEMENT

1. Check the Rewind Idlers if the machine is noisy or does not wind up tape smoothly and rapidly during rewind, or if the Supply Reel is not braked properly when going from FORWARD to STOP.
2. Inspect the driving surfaces of both Rewind Idlers

for excessive or uneven wear. Inspect the driving surface of the Supply Reel Assembly. Clean away any oil or debris from all driving surfaces.

3. Set the Function Lever to STOP. Check that the Right Rewind Idler is clear of the Idler Stopper by 0.5 to 1 mm. See Fig. 4-13. If this condition does not exist, bend the Idler Stopper with a pair of pliers.
4. Check that the contacting surfaces of the Right and Left Rewind Idlers are parallel. If they are not, bend them by hand.
5. Set the Function Lever to STOP. Check that the Supply Reel Table, Left Rewind Idler, and Right Rewind Idler are contacting securely. Make sure at this time that the Right Rewind Idler is disengaged from the Take-up Reel Table by more than 1 mm. See Fig. 4-13. To replace the Rewind Idlers proceed as follows.
6. Set the Function Lever to FORWARD. Pry the Retaining Ring (E5) from the top of the Left Rewind Idler shaft using a screwdriver. Remove the fiber washer. Lift the Left Rewind Idler off its shaft.

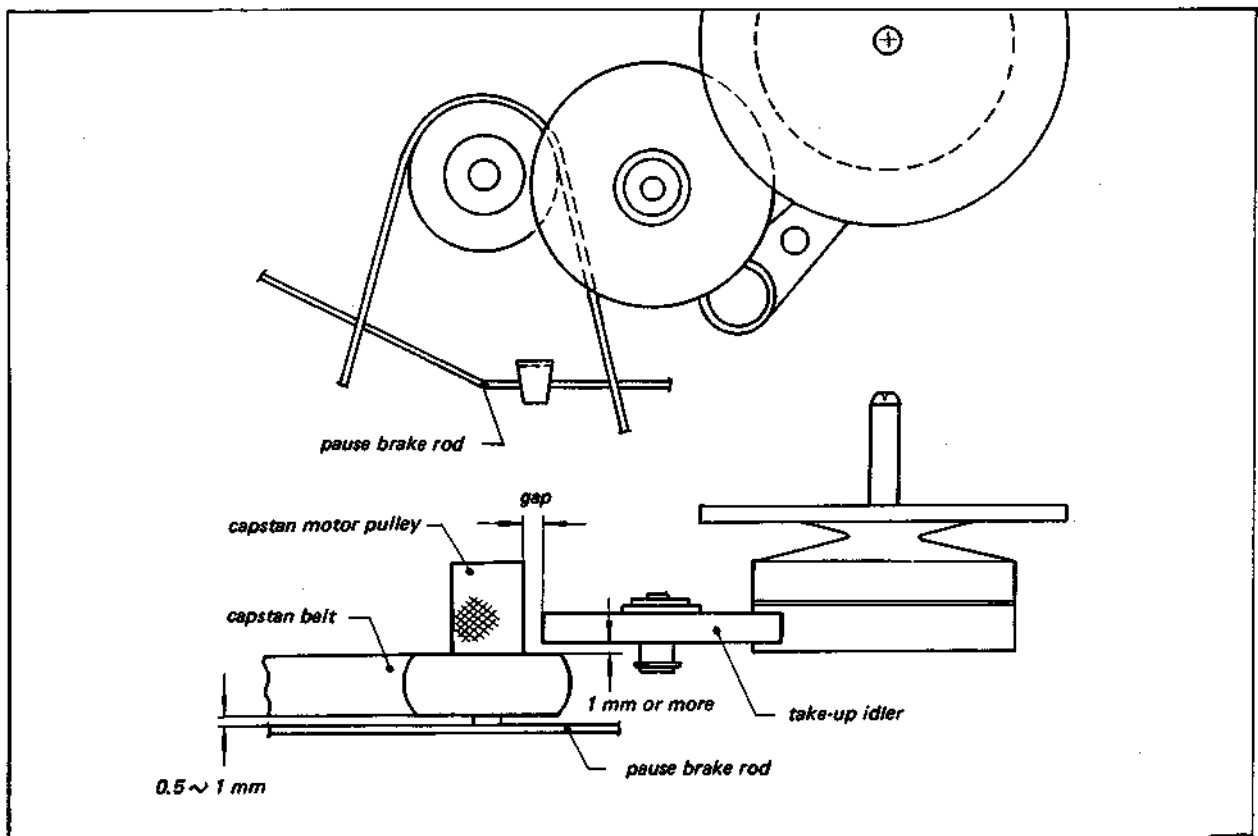

Fig. 4-11. Capstan motor pulley height

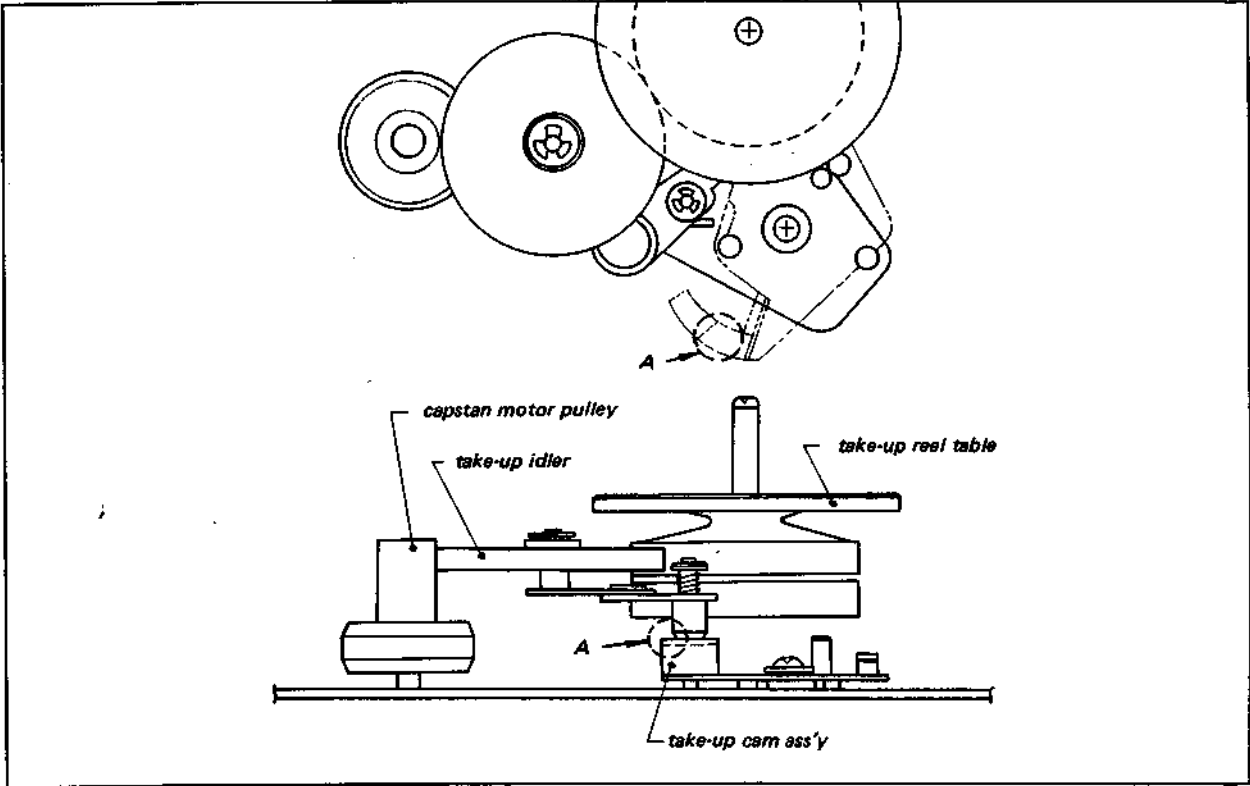

Fig. 4-12. Take-up idler height

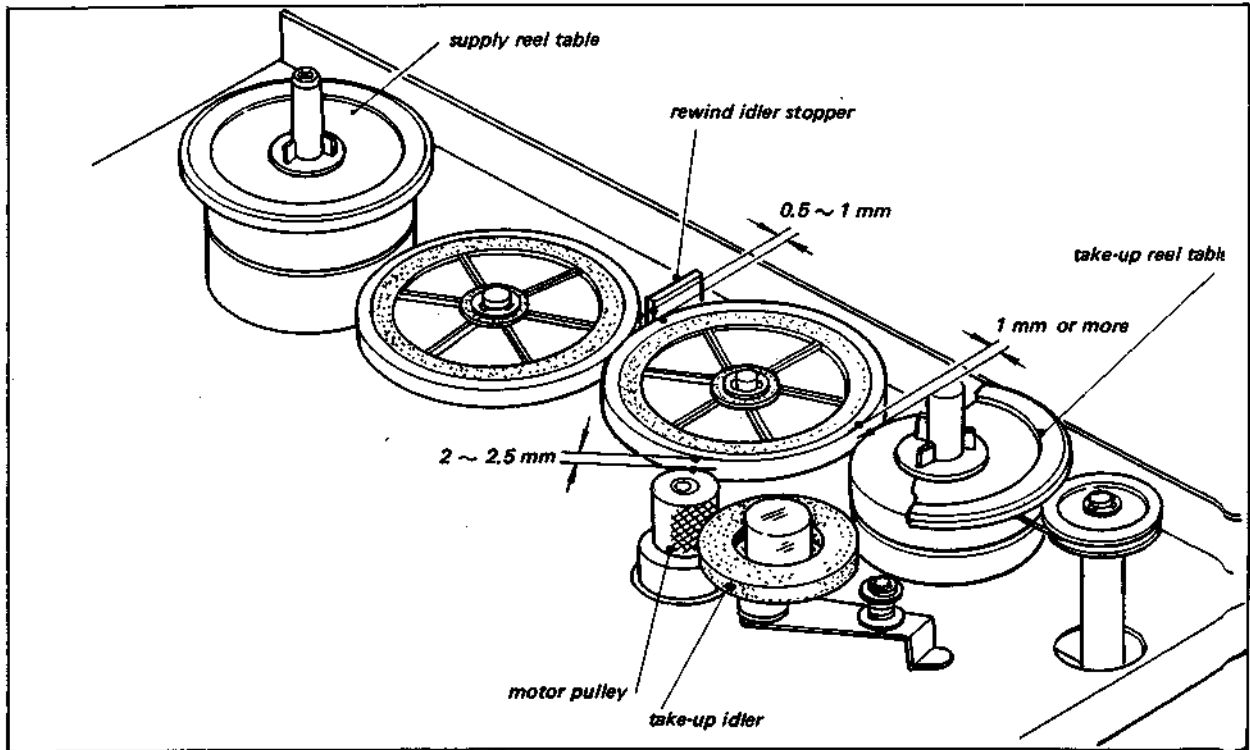

Fig. 4-13. Rewind idler replacement

Note: The directional brake will spring back counterclockwise when the idler is removed.

7. Inspect the idler to identify top and bottom so that the replacement will be installed correct side up.
8. Pry the Retaining Ring (E5) from the top of the Right Rewind Idler. Remove the fiber washer and push rod. Lift the Right Rewind Idler off its shaft.
9. To replace the Left Rewind Idler, first place one drop of oil on the idler shaft. Next, rotate the directional brake clockwise until the point faces

to the right (3 o'clock). Position the idler shaft so that the idler can be dropped onto the shaft. Release the directional brake. Install the fiber washer and the Retaining Ring.

10. Place a drop of oil on the shaft of the Right Rewind Idler. Install the Right Rewind Idler, the fiber washer, the push rod, and the Retaining Ring in that order.

4-12. BRAKE-SYSTEM ADJUSTMENT

System braking requires attention if:

- a. The Supply Reel exerts too much back tension during FORWARD and FAST FORWARD operations.

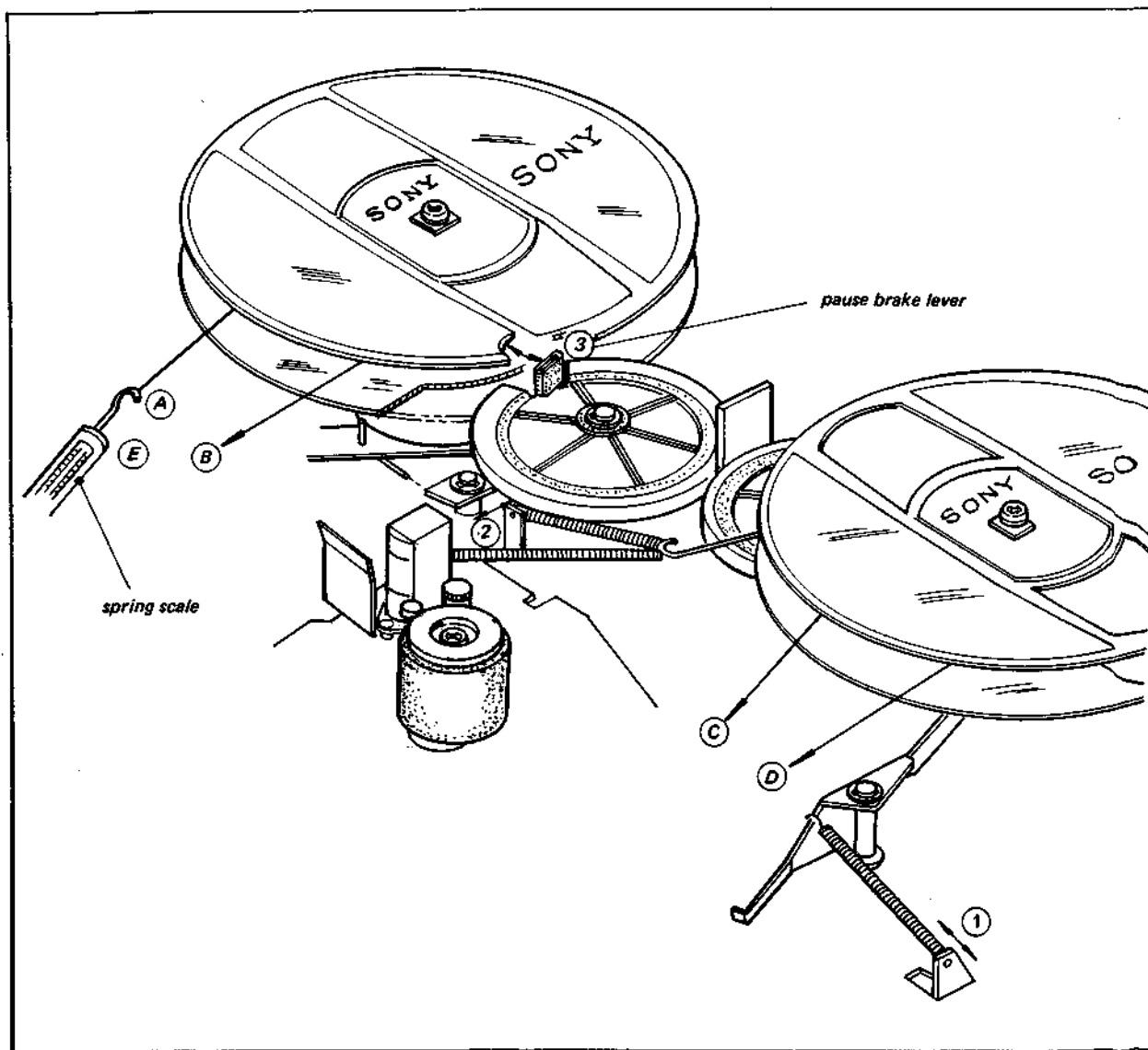

Fig. 4-14. Brake torque adjustment

- b. The Supply Reel pays out and slackens tape when going from FORWARD or FAST FORWARD to STOP.
- c. The Take-Up Reel exerts too much back tension during Rewind.
- d. The Take-Up Reel pays out too much tape when going from REWIND to STOP.
- e. The Supply Reel rotates during Pause operation.

Brake Torque Adjustment

1. Set the Function Lever to STOP.
2. Place an empty reel (RH-7V) with several turns of string wrapped around the hub onto the Supply Reel Table as shown in Fig. 4-14. Tie the reel to the spring scale. Pull the scale at a speed of approximately 4 inches/sec. Check the reading for brake torque. It should be more than 800 g-cm.
3. Repeat the above brake-torque checks for (B), (C) and (D) as indicated in Fig. 4-14. The brake torques should be less than 400 g-cm for the direction of (B) and (C) and more than 800g-cm for the direction of (D).
4. Bend Spring Supporting Brackets (1) and (2) with a pair of pliers, if necessary, to obtain the correct brake torques.

5. Set the Function Lever to PAUSE.
6. Repeat the procedure described in Step 2 for the direction indicated by (E) in Fig. 4-14. It should be more than 800 g-cm.
7. If necessary, bend the portion of the Pause Brake Lever identified by (3) with a pair of pliers.

Take-Up Brake Lever Check

1. Set the Function Lever to STOP.
2. Check that the top end of the Brake Lever is disengaged from the Function Selector Cam by approximately 2 mm. Refer to Fig. 4-15 (a).
3. Set the Function Lever to REWIND.
4. Check for a clearance of approximately 2 mm between the Brake Lever and the Take-Up Reel Table.
5. If necessary, bend the portion of the Brake Lever identified by "A" with a pair of pliers.

Pause Brake Lever Check

1. Set the Function Lever to REWIND.
2. Check for a clearance of approximately 1 mm between the Pause Brake Lever and the Supply Reel Table.
3. If this condition does not exist, turn nut "A" shown in Fig. 4-16.
4. Advance the tape. Check that the tape stops running in the PAUSE mode.
5. In the PAUSE mode, check for play between the Brake Lever and the nut.

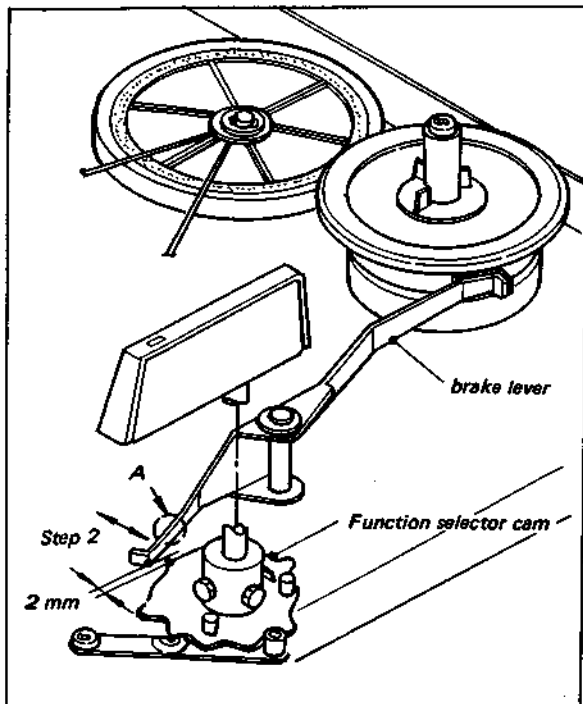

(a) STOP mode

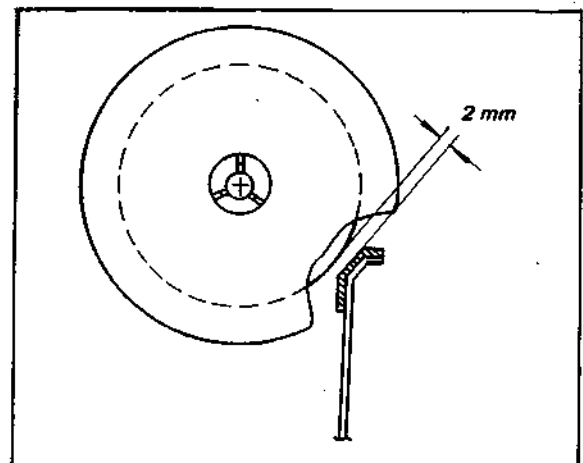

(b) REWIND mode

Fig. 4-15. Take-up brake lever check

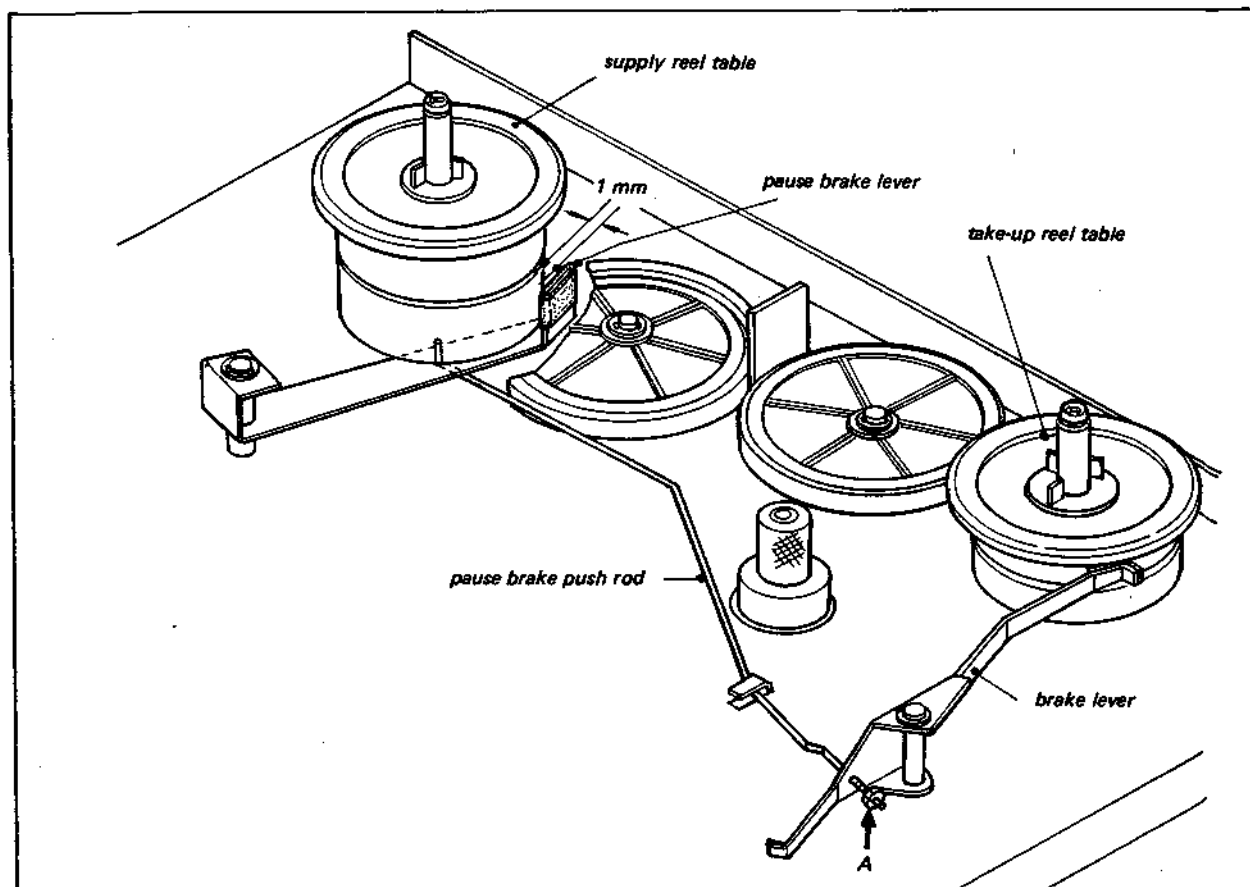

Fig. 4-16. Pause brake lever check

6. Place the Function Lever in all the modes except PAUSE. Check for clearance between the Pause Brake Lever and the Supply Reel Table. The clearance should be more than 0.5 mm.

Brake Timing Adjustment

1. Set the Function Lever to STOP. Check for a 2-2.5 mm clearance between the Capstan Motor Pulley and the Right Rewind Idler. Bend Take-Up Cam Push Rod A with a pair of pliers as needed to obtain the correct spacing. See Fig. 4-17.
2. Move the Function Lever from REWIND to STOP very slowly. Check that the Take-Up Reel Table braking is applied before the Right Rewind Idler stops rotating.
3. Move the Function Lever from FAST FORWARD to PAUSE very slowly. Check that Supply Reel Table braking is applied before the Take-Up Reel Table stops running.
4. Thread a tape on the VTR and advance it until all the tape is on the Take-Up Reel Table.

Move the Function Lever from REWIND to STOP. Check that the tape stops without excess slack. If it does not, bend the Brake Lever with a pair of pliers. There should still be at least 0.5 mm clearance between the Brake Lever and the Takeup Reel Table.

5. Place a full reel of tape on the Supply Reel Table. Move the Function Lever from FAST FORWARD to PAUSE. Repeat the procedure described in Step 4. If necessary, bend the Pause Brake Lever with a pair of pliers. Refer to "Pause Brake Lever Check" on page 4-12.

4-13. MOTOR REPLACEMENT

If the motor is suspected to be defective, check the mechanical load on the motor to make sure that the Capstan and Rotary Head Drum Assembly turn freely. Check for line voltage between the black and white leads of the motor (set the Function Lever to FORWARD). Also check phasing capacitor C001 in

series with the green lead of the motor. If line voltage is present and the phasing circuit is correct, but the motor does not turn, replace the motor as follows.

1. Stand the machine on its left side.
2. Cut the white and black motor leads at the terminal strip. Cut the green motor lead at the terminal of phasing capacitor C001. Leave 1/8" insulation on the stubs of the leads remaining on the terminal strip and the phasing capacitor. The colored insulation will aid in locating the correct tie points for the new motor.
3. Remove the drive belt for the Rotary Head Drum Assembly.
4. Inspect the lower drive pulley on the motor shaft

and note the position of the fan on the shaft. The bottom of the fan hub should be almost flush with the lower end of the motor shaft.

5. Loosen the set screw in the lower drive pulley and remove the drive pulley and fan.

Note: Do not remove the gray plastic fan from the lower drive pulley.

6. Remove the Terminal Block Bracket for the Motor Assembly.
7. Set the Function Lever to PAUSE. Hold the motor with one hand and back out the four Phillips-head screws from the top of the chassis. See Fig. 4-18.
8. Remove the upper (knurled) drive pulley (Capstan

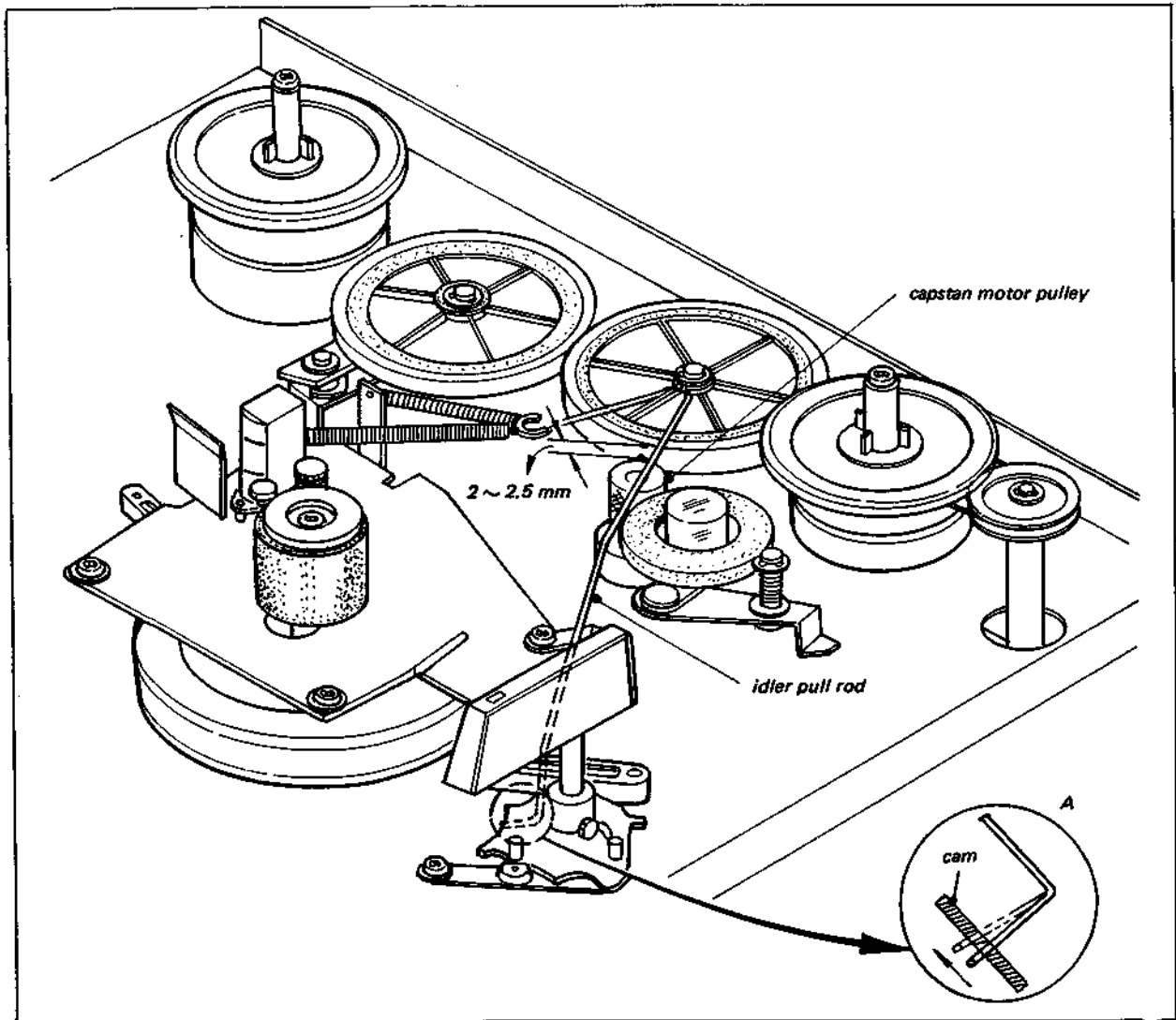

Fig. 4-17. Brake timing adjustment

If not, bend the Section "A" of the sensing wire with a pair of pliers or turn the split nut at "B" shown in Fig. 4-20.

5. Set the Function Lever to the REWIND mode. Check that the microswitch turns off before the sensing wire is more than 3 mm beyond the tape running surface. If not, reposition the microswitch as follows:
6. Loosen the two screws that secure the microswitch to the mounting bracket or the two screws that fasten the mounting bracket to the chassis. Slide the bracket or microswitch to obtain the correct condition. See Fig. 4-20.
7. Make sure that the microswitch turns off the motor correctly in each mode.
8. Make sure that the sensing wire operates smoothly without touching the Tape Guide or the Tapered Guide.

4-16. CAPSTAN BEARING AND SHAFT REPLACEMENT

A worn Capstan Bearing results in noisy operation (a squealing sound from the capstan). When it becomes necessary to replace the Capstan Bearing, the Capstan Shaft (assembly including the Flywheel) must be replaced as well.

Proceed as follows.

1. Remove the Reel Panel.
2. Remove the screw securing the Capstan and pry off the Capstan.
3. Remove the retaining washer holding the Pull Rod to the Right Rewind Idler Shaft. Remove The Pull Rod from the Idler Shaft.
4. Remove the two springs from the Rewind Idler Push Rod.
5. Remove the four screws securing the Capstan Deck Ass'y to the support on the chassis.

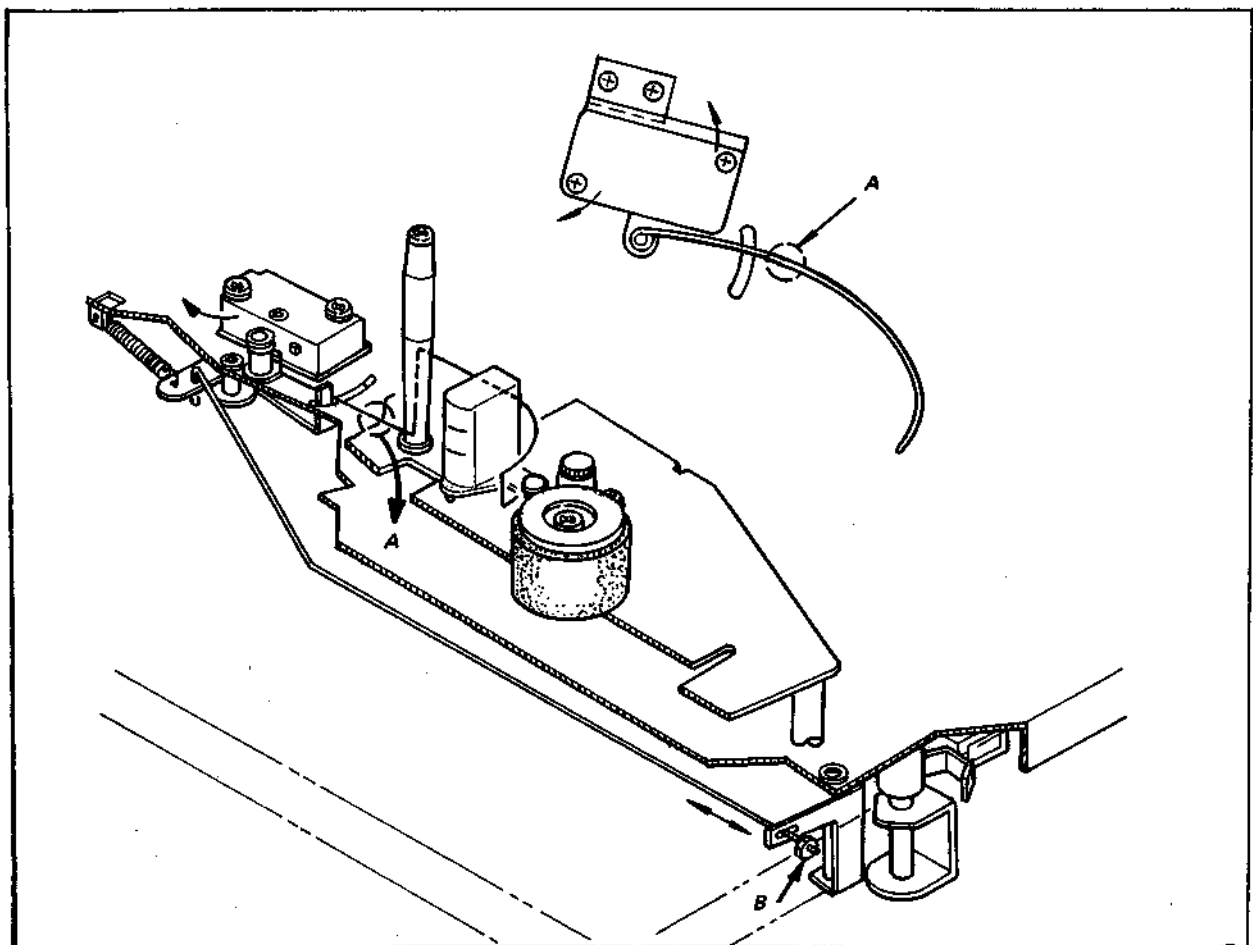

Fig. 4-20. Automatic shutoff switch adjustment

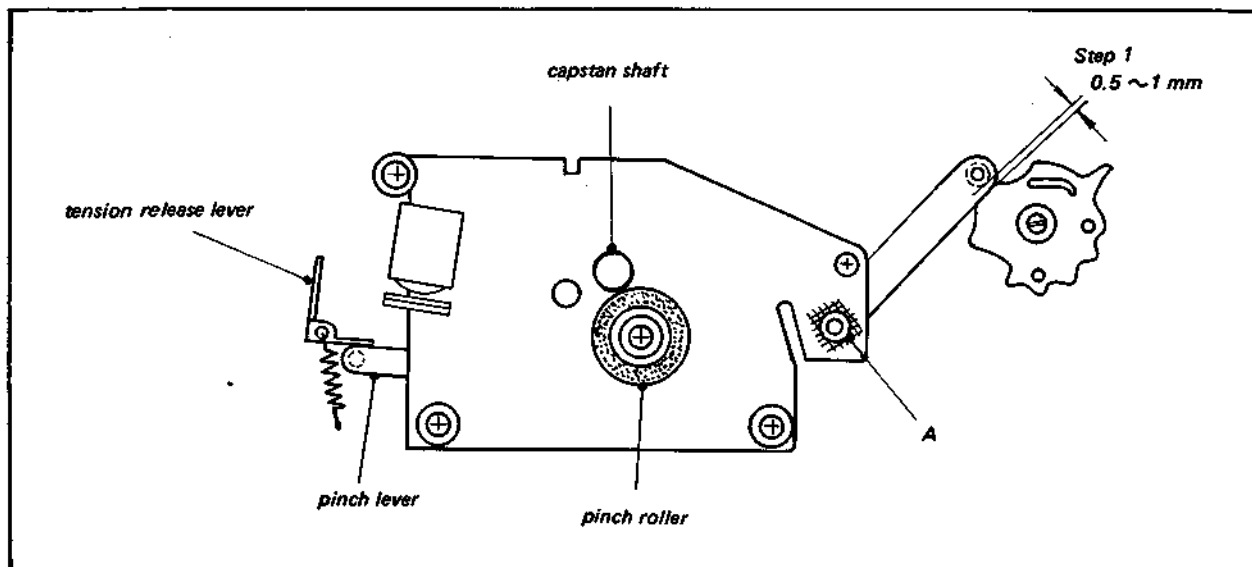

Fig. 4-21. Capstan deck adjustment

6. Lift up the Capstan Deck Ass'y. Take the drive belt off the Flywheel.
7. Pull the Capstan Shaft Ass'y (Flywheel) off the Capstan Bearing on the Capstan Deck.
8. Fold the Capstan Deck Ass'y back and remove the Capstan Bearing Retainer by removing the three screws.
9. Remove the Capstan Bearing Cap from the Capstan Bearing Oil Ring and Oil Ring Retainer using a screwdriver. Remove the Capstan Bearing.
10. Before installing the new Capstan Bearing inspect the replacement. Pass a clean lint-free cloth through the capstan hole, and inspect the inner surfaces for dirt or foreign matter.
11. Inspect the new Capstan Shaft Assembly. Handle the Capstan Shaft carefully to avoid scratches or nicks on the bearing surface.
12. Insert the Capstan Bearing into the Capstan Deck and put the Capstan Bearing Retainer on the Capstan Bearing. Tighten the three screws that secure the retainer to the chassis.
13. Place a few drops of oil on the inner surface of the bearing.
14. Put the Spacer on the Capstan Shaft. Insert the shaft into the Capstan Bearing.
15. Hold the Flywheel with one hand and slip the Oil Ring Retainer and Oil Ring onto the shaft. Place a few drops of oil on the Oil Ring, then put the Bearing Cap on the Capstan Bearing.
16. Reinstall the capstan drive belt. Reinstall the new Capstan and replace the mounting screw.
17. Put the Capstan Deck Assembly with Flywheel on the four posts of the chassis. Position the Pinch Lever with relation to Tension Release Lever as shown in Fig. 4-21.
18. Tighten the four screws that secure the Capstan Deck Assembly to the capstan deck supports.
19. Reconnect the Pull Rod Spring to the Pull Rod.
20. Install the Pull Rod and retainer onto the Rewind Idler Shaft.

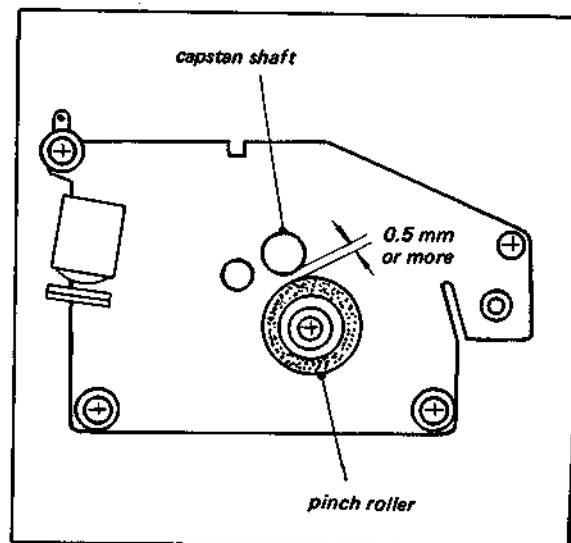

Fig. 4-22. Capstan deck adjustment

Pulley) from the top of the motor shaft.

9. Note the position of the hum belt (the steel band that surrounds the motor). Loosen the two screws that apply tension to the hum belt and remove the belt.
10. Install the hum belt on the new motor. Position the mounting screws as shown in Fig. 4-18. Make sure that the hum belt straddles the two end bells equally.
11. Install the top (knurled) drive pulley on the upper motor shaft. Space the bottom edge of the pulley about 4 mm from the top of the motor.
12. Insert the screws with spring washers (PS 4 x 8) through the mounting holes at the top of the chassis.
13. Put the motor in place beneath the chassis with the leads coming out toward the bracket. Make sure that the upper pulley is inside the loop of the

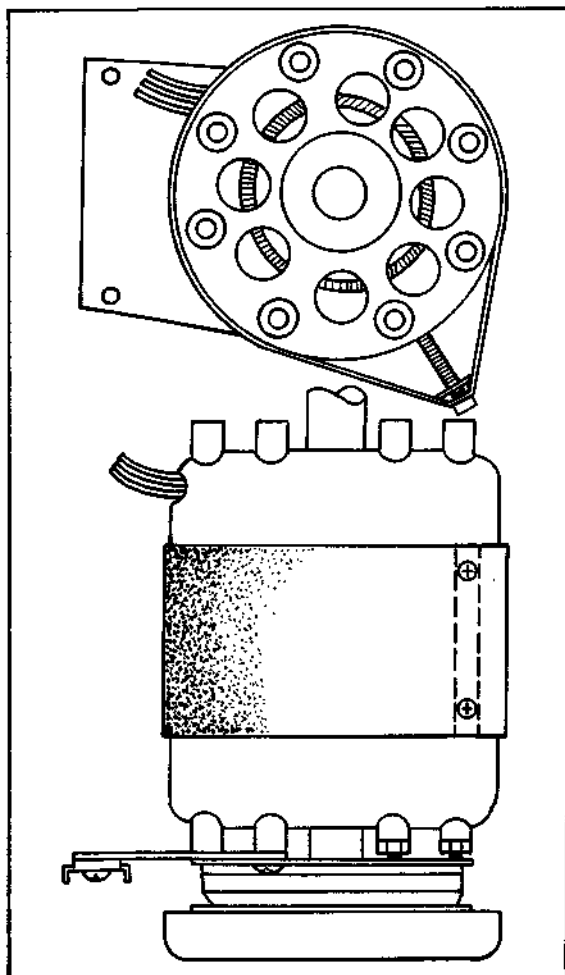

Fig. 4-18. Installation of the motor hum belt

capstan drive belt. Thread the screws installed in Step 12 into the motor end bell.

14. Install the screws in the Terminal Block Bracket (into the lower end bell).
15. Tighten all screws.
16. Check the Capstan Drive Belt to make sure it is placed properly on the Flywheel.
17. Install the lower drive pulley. Refer to Step 4 for the proper position.
18. Slide the plastic sleeve over the motor leads. Solder the motor leads to the following tie points:
 black terminal 3 of the terminal strip
 white terminal 5 of the terminal strip
 green common lug of C701
19. Install the Rotary Head Drum Assembly drive belt.
20. Operate the motor and check the FORWARD, FAST FORWARD, and REWIND operations. Check the running position of the lower drive belt as directed in Section 4-4.

5-14. RECORD BUTTON LATCH LINKAGE

1. Check that the RECORD and AUDIO DUB buttons can be pushed and locked only in the STOP and the PAUSE modes.
2. If the latch does not operate correctly, proceed as follows.
3. Make sure that the Record Button is clear of the Audio Set Lock Bar. Clearance should be between 0.1 and 0.3 mm. Bend "A" with a pair of pliers as needed to obtain the correct spacing. Refer to Fig. 4-19.
4. Push the RECORD Button. Check that the slide switches on the V2, A, and SV circuit boards are actuated.
5. Push the AUDIO DUB Button. Check that the slide switch on the A circuit board is actuated. If the switches do not operate correctly, proceed as follows.
6. Check for 2 mm clearance (or less) between Slide Plate B and the split nut with the AUDIO DUB Button released.
7. Turn the split nut of the Slide Switch Lever to adjust the stroke of Slide Plate C. If necessary, bend the Slide Switch Lever with a pair of pliers.
8. Adjust the Slide Switch Springs if necessary until

the clearance between the ends of the slide switches on V2, A, and SV, circuit boards and the Slide Switch Springs E, F, and C is approximately 1 mm. The Slide Switch Springs are wire leaf-type springs.

9. Actuate and release the RECORD and AUDIO DUB Buttons a few times. Check that the slide switches operate correctly.

4-15. AUTOMATIC SHUTOFF SWITCH ADJUSTMENT

To check the operation of the Automatic Shut-Off Switch, turn on the power and proceed as follows.

1. Remove the tape from the normal tape path. Set

the Function Lever first to FORWARD, then to PAUSE, FAST FORWARD, and REWIND. The motor should shut off in each position after about 1 second. Repeat this check with tape threaded properly. The motor should remain on when the Function Lever is set to FORWARD, PAUSE, FAST FORWARD, and REWIND.

2. Set the Function Lever to STOP, and depress the RECORD button. The motor should turn on.
3. Thread the tape on the VTR. Make sure that the motor is not shut off by a slight overshoot of the tape sensing wire. If the aforementioned conditions are not met, proceed to the following steps.
4. Set the Function Lever to STOP. Check for approximately 5mm clearance between the tape surface and the sensing wire.

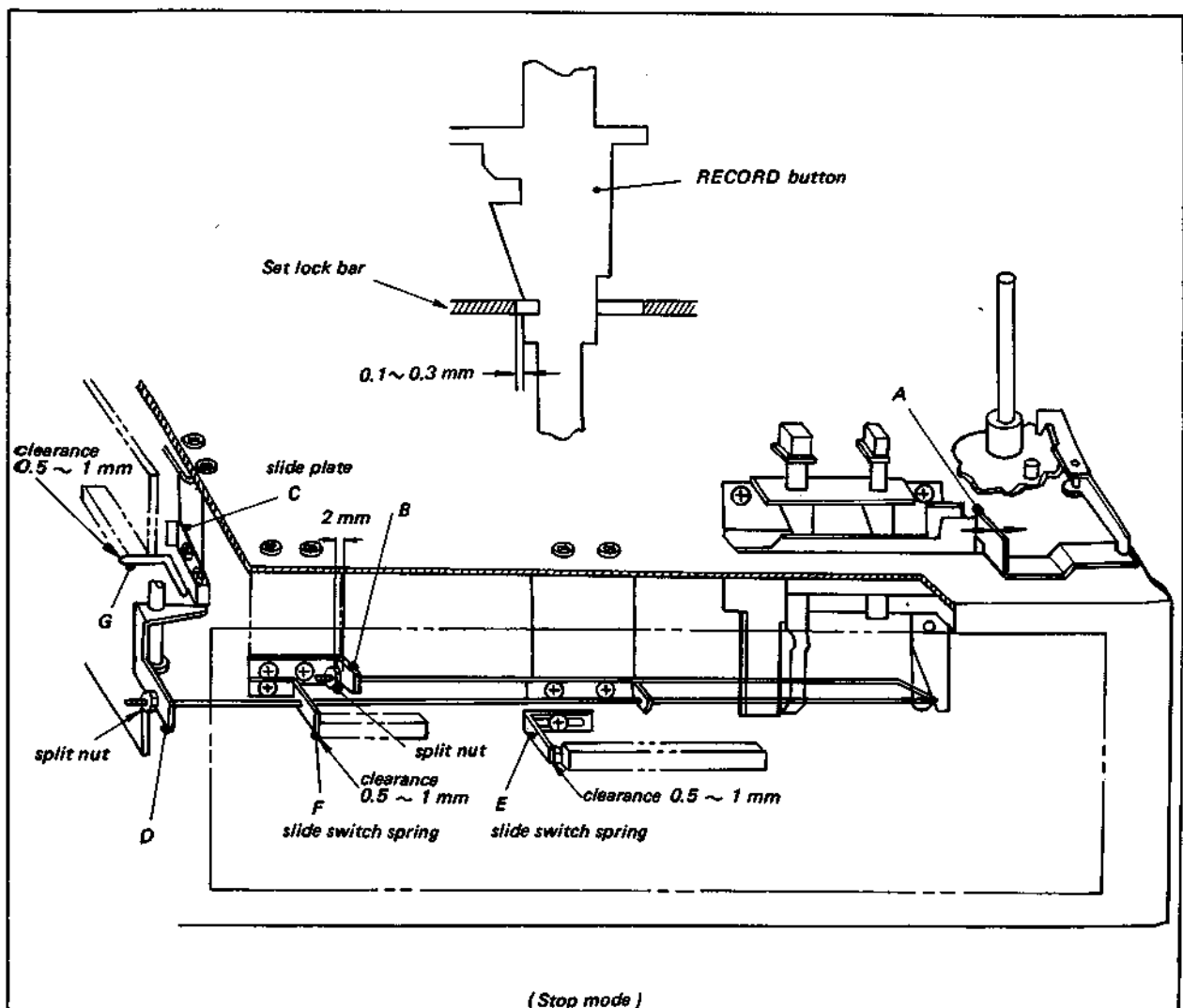

Fig. 4-19. RECORD button latching mechanism and adjustment

21. Operate the machine. Check servo tracking and Audio/Control Head Adjustment. See Section 4-9.

4-17. CAPSTAN DECK ASSEMBLY ADJUSTMENT

1. Set the Function Lever to FORWARD. Check that the clearance between the Pinch Lever and the Function Selector Cam is 0.5 to 1 mm. If necessary, readjust the position of the Capstan Deck Assembly. See Fig. 4-21.
2. Set the Function Lever to PAUSE. Make sure that the clearance between the Capstan Shaft and the Pinch Roller is more than 0.5 mm. If necessary, recheck Step 1.
3. Set the Function Lever to FORWARD. Check that the clearance between the upper end of the Pinch Lever and the lower end of the Drum Mounting Deck is more than 1.5 mm. See Fig. 4-23. If it needs adjustment, bend "A" in Fig. 4-21, with a pair of pliers. Recheck Pinch Roller Pressure as described in Section 4-18.
4. Switch the Function Lever through all modes.

Check the tape motion.

4-18. PINCH ROLLER

Pinch Roller Replacement

Replace a worn or damaged Pinch Roller as follows.

1. Place the VTR in the STOP mode.
2. Remove the Pinch Roller Retainer and mounting screw from the top of the Pinch Roller.
3. Lift off the Pinch Roller.
4. Remove the Pinch Roller Spacer and the Pinch Roller Oil Ring from the top of the Pinch Roller.
5. Install the Pinch Roller Spacer and the Pinch Roller Oil Ring on the top of the replacement Pinch Roller.
6. Place the Pinch Roller Assembly on the Pinch Roller Shaft.
7. Install the Pinch Roller Retainer and mounting screw.

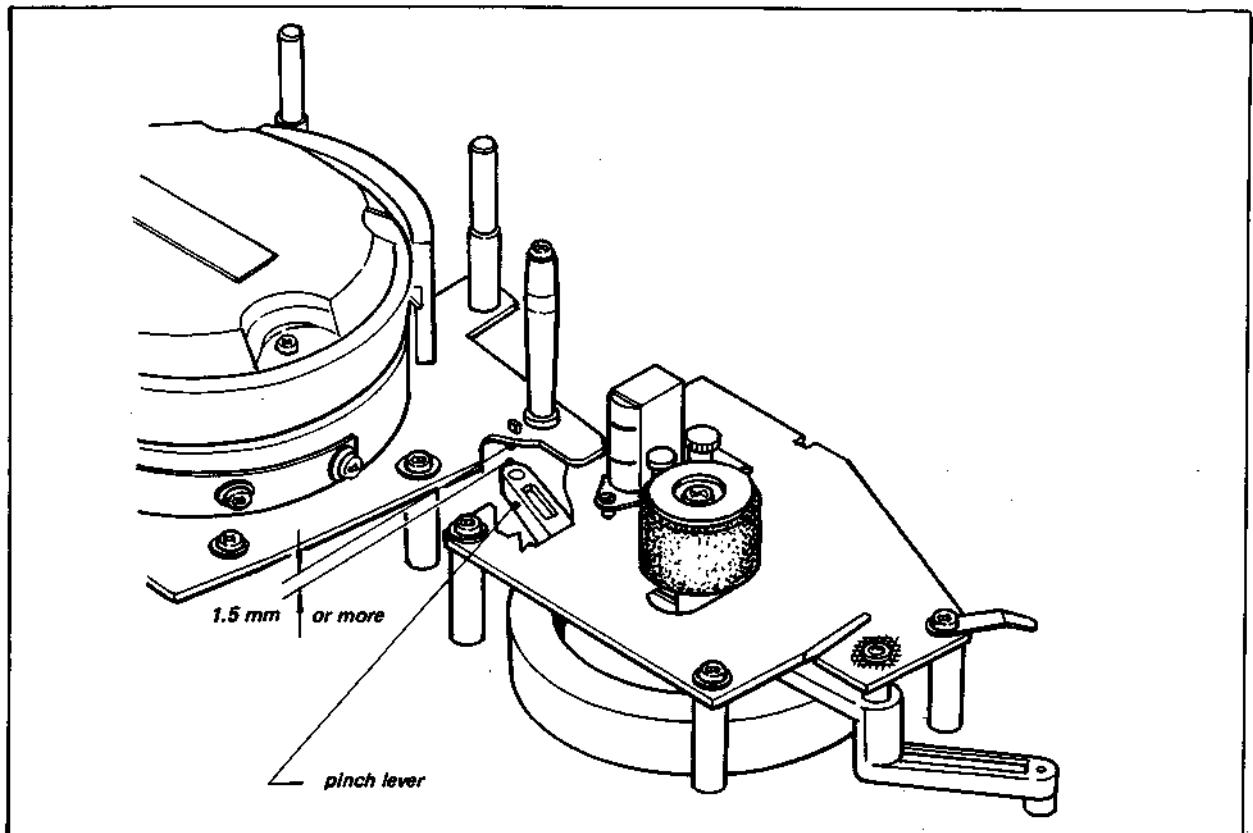

Fig. 4-23. Pinch lever adjustment

8. Test the Pinch Roller to see that it spins freely.

Pinch Roller Pressure Adjustment

1. Set the Function Lever to FORWARD. Check for 0.1 mm clearance between the lower end of the Pinch Roller and the Capstan Shaft when the upper end of the Pinch Roller contacts the Capstan Shaft. See Fig. 4-24. Bend "A" in Fig. 4-21 with a pair of pliers as needed to obtain the correct spacing.

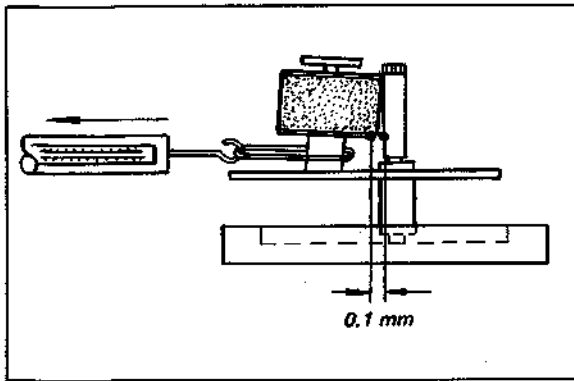

Fig. 4-24. Pinch roller adjustment

2. Place the Function Lever in the FORWARD position. Make a loop in a piece of string and attach the spring scale around the base of the Pinch Roller Shaft. See Fig. 4-24. Pull the scale in the direction indicated by the arrow. Check the reading when the Pinch Roller just leaves the Capstan Shaft. It should be between 1.5 and 2.2 kg.

4-19. MICROWITCH MAINTENANCE AND ADJUSTMENT

1. Set the Function Lever to the STOP mode. Make sure that the switching button of the microswitch (SW 4, under the chassis, beneath the Function Lever) is in the center of the Cam. See Fig. 4-25. Note, the microswitch (SW 4) turns off with the pushbutton pressed.
2. If it does not operate normally, loosen the mounting screw and readjust the position of the Microswitch Assembly within the slot of the Microswitch Mounting Bracket. After adjustment, apply a suitable locking compound to the mounting screw.
3. Coat the Cam contacting surface with grease.

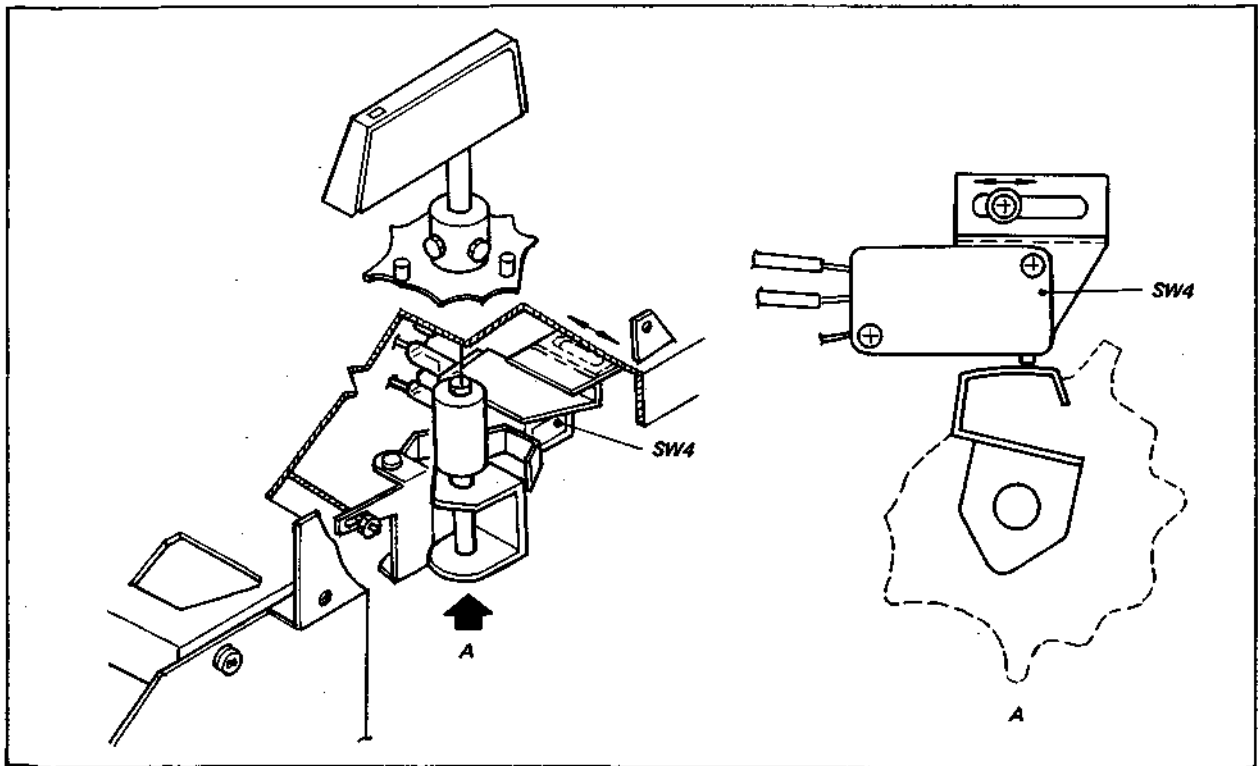

Fig. 4-25. Microswitch adjustment

SECTION 5

VIDEO SYSTEM ALIGNMENT

EQUIPMENT REQUIREMENTS

The following test equipment is suggested for use in SONY Authorized Service Stations.

- a. TV monitor –SONY CVM-51UW/UWP
- b. Oscilloscope –Tektronix Type 310A, Heath IOW-14, or equivalent
- c. Audio Generator –Heath IGW-72 or equivalent
- d. AC VTVM (Audio) –Heath IMW-21, or equivalent
- e. Volt-Ohm-Milli-ammeter –Simpson 260, or equivalent
- f. Prerecorded Test Tape –
- g. Video Signal Generator –Eico 380
- h. R-F Signal Generator –RCA WR-50B, or equivalent

The following test equipment is required for use at Factory Service Stations.

- a. TV monitor –SONY CVM-51UW/UWP
- b. Oscilloscope –Tektronix 422, 561A with 3A1, 3B3 plug-ins or equivalent
- c. Video Signal Generator –Teletet 3502A1, Stairstep Generator, or equivalent
- d. Audio Generator –Heath IGW-72,
- e. AC VTVM (Audio) –Hewlett Packard 400D, or equivalent
- f. Volt-Ohm-Milli-ammeter –Simpson 260, or equivalent
- g. Prerecorded Test Tape –SONY Alignment Tape, 7" reel
- h. R-F Signal Generator –Tektronix 191, or equivalent

**5-1. MAXIMUM DEVIATION ADJUSTMENT
(Sync Tip Carrier Frequency, Deviation,
Dark Clip, & Video Output Level)**

Test Point/Board: TP-105/V2 (Modulator video input)
TP-302/V1 (Limiter output)
TP-305/V1 (Video output)

Adjust for: 1.0 V (p-p) video output with 3.2 MHz to 4.6 MHz modulator input.

Adjustment/Board: R126/V2 (Sync Tip Carrier Frequency)
R137/V2 (White Clip)
R155/V2 (Dark Clip)
R121/V2 (Deviation Set)
R335/V1 (Video Output Level)

Signal Source: (1) Stairstep signal
(2) Camera or telecast signal, preferably a test pattern.

Equipment Required: (1) Oscilloscope
(2) Video signal generator
(3) SONY Alignment Tape

Set-up: See Fig. 5-1a.

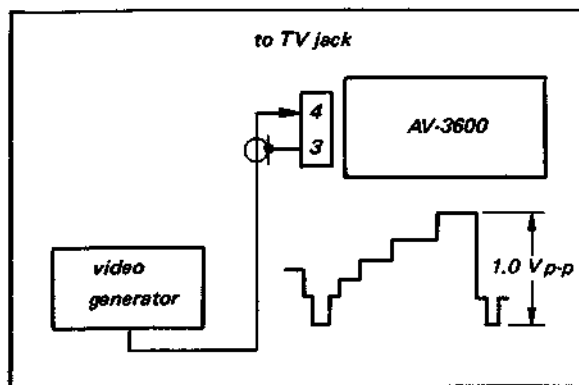

Fig. 5-1a. Maximum deviation adjustment set-up

Procedure A:

1. Play back the SONY Alignment Tape.
2. Connect a scope to TP-305.
3. Adjust R335 (Video Output Level) for 1.0 volt (p-p).
4. Set up the E-to-E mode with no input signal.
5. Connect the scope to TP-302.

6. Adjust R126 (Sync Tip Carrier Freq.) for 3.2 MHz as indicated on the scope screen. 3.2 MHz can be measured as follows.
 - a. Adjust scope time base for 0.5 μ sec per division (calibrated)*.
 - b. Set scope controls to obtain a stable trace. A correct carrier frequency of 3.2 MHz is indicated when there are 16 complete square waves in ten divisions. Set R126 to produce this indication. See Fig. 5-2a.
7. Set up the E-to-E mode using a stairstep signal of 1.0 volt (p-p).
8. Connect the scope to TP-305.
9. Set R121 (Deviation Set) to produce 1.0 volt (p-p).
10. Set up the E-to-E mode using a telecast signal, preferably a test pattern.
11. Connect the scope to TP-105. Set the time base to 2 msec/cm.
12. (Omit this step for these sets having a serial number below 10,550, as these machines are not equipped with Dark Clip Adjustment R155). Adjust R155 so that the negative spike in the vertical blanking pulse falls 50% below sync tip amplitude. See Fig. 5-1b.
13. Adjust R137 (White Clip) so that extreme peak-white parts of the waveform are $A + \frac{A}{2}$ volts (p-p) as shown in Fig. 5-1b

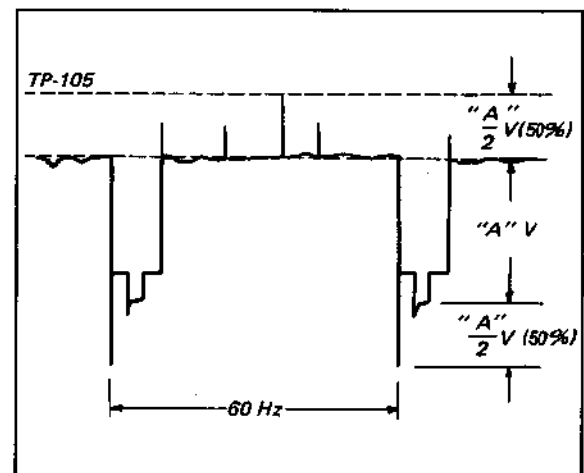

Fig. 5-1b. White clip and dark clip levels

* Check the scope time-base calibration before making this adjustment.

Procedure B:

If the SONY Alignment Tape is not available, proceed as follows.

1. Set up the E-to-E mode with no input signal.
2. Connect the scope CHANNEL 1 input to TP-302 and CHANNEL 2 to TP-105.
3. Set the scope MODE Switch to ALTER and TRIGGERING COUPLING to AUTO.
4. Set R137 (White Clip) fully counterclockwise.
5. Adjust R126 (Sync Tip Carrier Freq.) for a stable trace of 3.2 MHz. (Refer to Step 6 in Procedure A).
6. Note the position (dc voltage level) of the trace on CHANNEL 2 with reference to the trace on CHANNEL 1 (as obtained in Step 5). See Fig. 5-2a.
This trace indicates the dc level of the modulator input required to produce 3.2 MHz at the modulator output. Do not reset the vertical POSITION control of CHANNEL 2 until this adjustment is complete.
7. Readjust R126 for 4.6 MHz as indicated on the scope. A correct frequency of 4.6 MHz is indicated when there are 23 complete square waves in ten divisions when the time-base is set to 0.5 $\mu\text{sec}/\text{cm}$.
8. Note the position (dc voltage level) of the trace on CHANNEL 2 with reference to the trace on CHANNEL 1 (as obtained in Step 7). See Fig. 5-2b. Mark the scope graticule.
9. Apply a staircase signal of 1.0 volt (p-p) to the TV jack. See Fig. 5-1a.
10. Readjust R126 (Carrier Frequency) so that the sync-tip part of the waveform corresponds to the position of the trace measured in Step 6. See Fig. 5-2c.
11. Adjust R121 (Deviation Set) so that the "top step" peak-white part of the signal corresponds to the position of the trace measured in Step 8. See Fig. 5-2c.
12. Make sure that a carrier frequency of about 3.6 MHz is indicated on the scope with no signal input. Repeat Steps 5 to 11, if necessary. Video Level is now set to produce the maximum deviation allowed by the system.
13. Adjust R335 (Video Output Level) to obtain 1.0 volt (p-p) at TP-305.

14. Proceed with Steps 11 to 13 in Procedure A for the Dark and White Clip Settings.

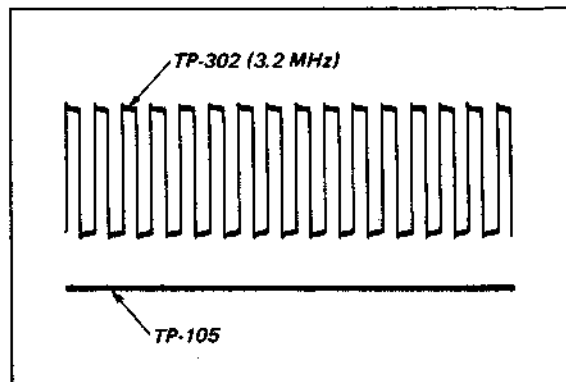

Fig. 5-2a. Waveforms in Steps 5 and 6

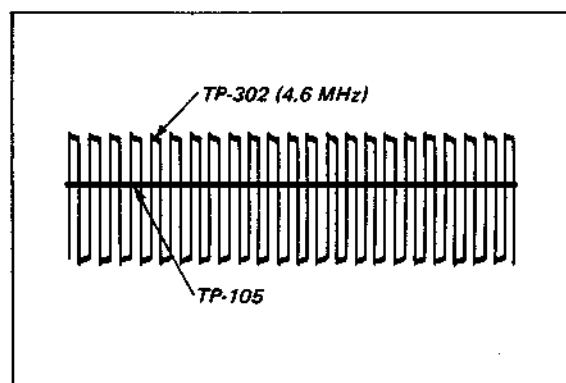

Fig. 5-2b. Waveforms in Steps 7 and 8

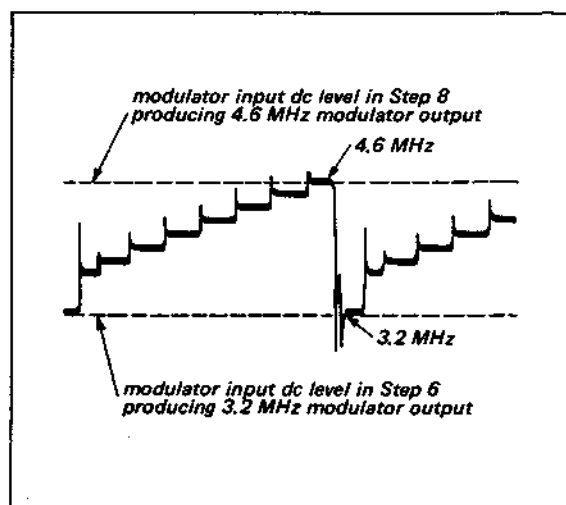

Fig. 5-2c. Maximum deviation setting

5-2. CARRIER LEAK ADJUSTMENT

The fm signal waveform must be symmetrical throughout the rf system, from the modulator to the demodulator or carrier energy will appear in the picture as a herringbone pattern.

Test Point: Monitor screen

Adjust for: Minimum carrier leak in the picture.

*Adjustment/
Board:*

R305/V1 (Limiter Carrier Balance)
R326/V1 (Freq. Doubler Carrier Balance)

R148/V2 (Modulator Carrier Balance)

C122/V2 (Modulator Carrier Balance)

Signal Source: Camera signal or telecast signal

Equipment

Required: (1) TV monitor
(2) SONY AV-Series camera

Procedure:

1. Check carrier frequency and maximum deviation. See Sec. 5-1.

Note: Because the procedure in Sec. 5-1 is lengthy and somewhat complicated, it may be checked and, if necessary, readjusted after Sec. 5-2. If the procedure in this section does not yield correct results, however, carrier frequency and maximum deviation must be set (Sec. 5-1).

2. Set up the E-to-E mode using a camera or telecast signal.
3. Adjust R305 (Limiter Carrier Balance)* and R326 (Freq. Doubler Carrier Balance)** for minimum carrier leak (herringbone). Repeat both adjustments.
4. Adjust R148 (Modulator Carrier Balance) and C122 (Modulator Carrier Balance) for minimum carrier leak. Repeat both adjustments.†
5. Repeat Steps 3 and 4.
6. Make a recording.
7. Play back the tape and observe the picture. If carrier leak is still visible, trim up R305 and R326 to minimize carrier leak in the playback picture.

Note: *This adjusts the operating point of Q302 so that the limiter stages produce symmetrical output waveforms.

** This is set to obtain a uniform-amplitude detected (frequency doubled) fm signal.

† These components adjust the operating point and the RC time constant of the multivibrator (modulator) so that it produces a symmetrical output waveform.

5-3. RECORD CURRENT ADJUSTMENT

The following adjustment sets the level of signal applied to video heads for recording.

*Test Point/
Board:*

TP-203/V2 (Rec. Current, Ch A)

TP-204/V2 (Rec. Current, Ch B)

Adjust for: 1 V (p-p) rf output at TP-203 (Ch A) and an equalized rf output at TP-204 (Ch B).

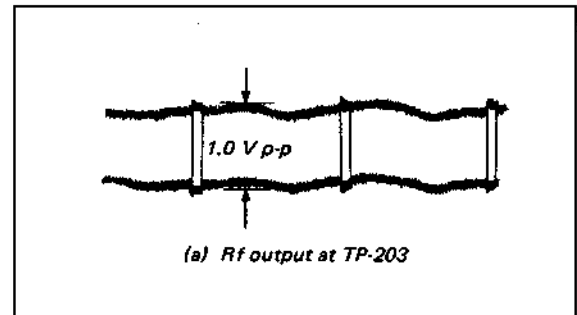

(a)

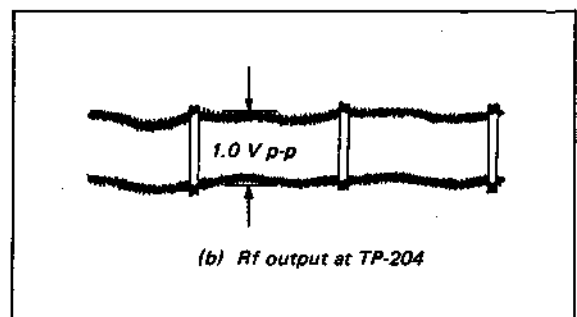

(b)

Fig. 5-3. Record current adjustment

Adjustment/Board: R225/V2 (Rec. Current)
R217/V2 (Rec. Current Balance)

Signal Source: Camera or telecast signal.

Equipment Required: (1) Oscilloscope
(2) SONY AV-Series camera or TV monitor.

Procedure:

1. Set up the E-to-E mode using a camera or telecast signal.
2. Connect the scope to TP-203. Set the time base to 2 msec/cm.
3. Adjust R225 for a 1 V (p-p) output as shown in Fig. 5-3(a).
4. Connect the scope to TP-204.
5. Adjust R217 to equalize the amplitude at TP-204 to that at TP-203 in Step 3.

5.4. PLAYBACK PREAMPLIFIER ADJUSTMENT (Head Resonance and Playback Equalization)

Frequency characteristics of the playback amplifiers are adjusted to equalize head-to-tape characteristics and to obtain the desired overall frequency response.

Test Point/Board: TP-201/V2 (PB rf output)

Adjust for: Correct frequency response as shown in Fig. 5-4.

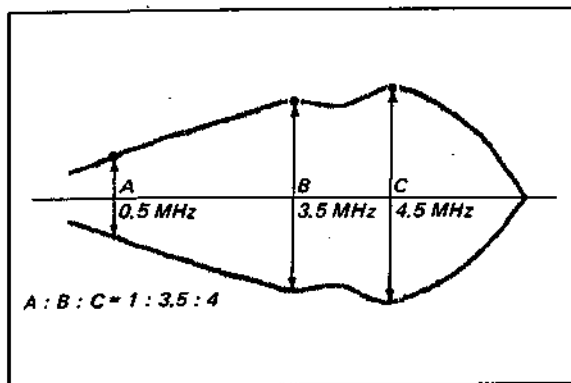

Fig. 5-4. Playback preamplifier frequency response

Adjustment/Board: C201, R201/V2 (Head Resonance, Ch A)
C202, R202/V2 (Head Resonance, Ch B)
L204/V2 (PB Equalization)
R211/V2 (PB Equalization)

Signal Source: Rf signal: 500 kHz, 3.5 MHz & 4.5 MHz

Equipment Required: (1) Oscilloscope
(2) Rf signal generator

Set-up: See Fig. 5-5.

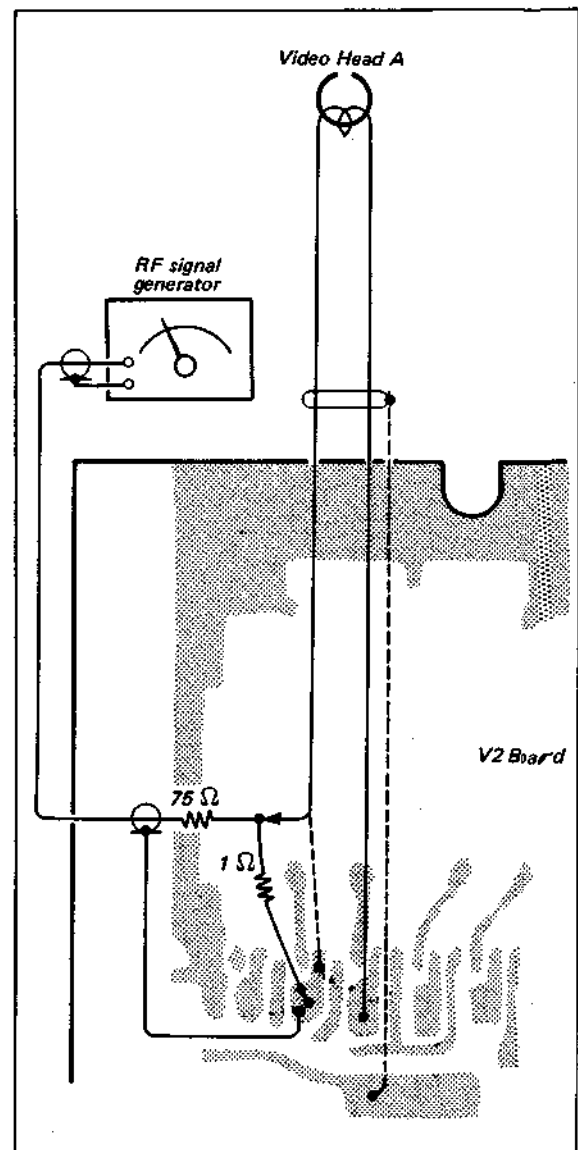

Fig. 5-5. Set-up for adjusting video-head resonance

Preparation:

1. Lift the orange lead of the cable to the "A" head at the V2 Board and connect the resistive network shown in Fig. 5-5.
2. Connect the Rf Signal Generator as shown.

Procedure:

(Head Resonance Adjustment)

1. Tune the Signal Generator to 4.5 MHz. Set output to 50 mV.
2. Turn on the Videocorder. Set the Function Lever to FORWARD.
3. Connect the scope to TP-201.
4. Adjust C201 to produce a maximum amplitude on the scope. Note the reading on the scope.
5. Tune the Signal Generator to 500 kHz. Keep the output at 50 mV.
6. Adjust R201 so that the amplitude at 500 kHz is one fourth that at 4.5 MHz (noted in Step 4), that is

$$\frac{\text{amplitude at 500 kHz}}{\text{amplitude at 4.5 MHz}} = \frac{1}{4}$$

Note the amplitude at 500 kHz.

7. Lift the orange lead of the cable to the "B" head at the V2 Board and connect the Rf Signal Generator in place, using the resistive network as in Steps 1 and 2 of "Preparation".
8. Adjust C202 and R202 of Channel B in the same manner as in Steps 1 to 6.
(Midrange Equalization Adjustment)
9. Tune the Rf Signal Generator to 3.5 MHz
10. Adjust L204 to produce maximum amplitude at TP-201. Note the reading on the scope.
11. Tune the Rf Signal Generator to 500 kHz.
12. Adjust R211 to produce the correct output amplitude at TP-201, as follows.

$$\frac{\text{amplitude at 500 kHz}}{\text{amplitude at 3.5 MHz}} = \frac{1}{3.5}$$

(obtained in Step 10)

The frequency response characteristic should now be set correctly as shown in Fig. 5-4.

SECTION 6

SERVO SYSTEM ALIGNMENT

The servo system alignment procedure and sequence is shown in Chart 6-1.

Drum-Speed Control System

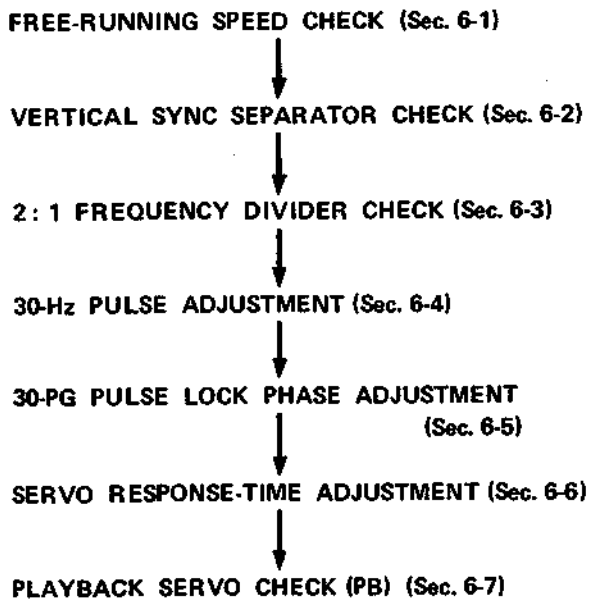

Phase Control System

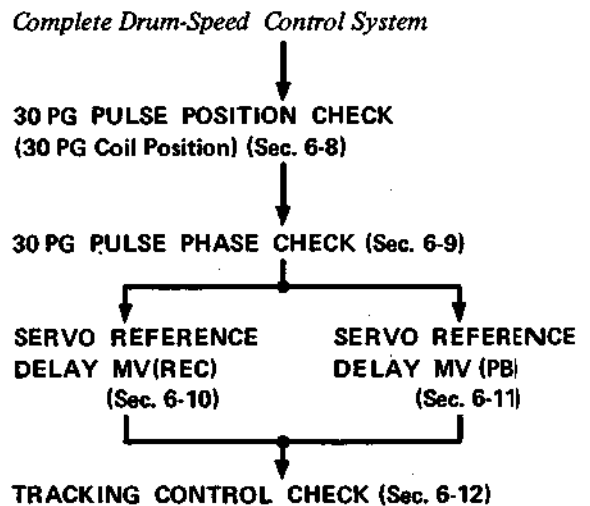

Camera Control System

VERTICAL SYNC FORMER CHECK (Sec. 6-13)

Chart 6-1. Servo system alignment

6-1. FREE-RUNNING SPEED CHECK

This test shows if the Rotary-Head Assembly rotates at the correct speed without servo correction.

Test Point/

Board: TP-412/SV (Shaped 30 PG pulse output)

Adjust for: 30.25 Hz to 30.35 Hz

Adjustment: Check the Rotary Head Drum Belt or refer to a SONY FACTORY SERVICE BRANCH.

Signal Source: None required

Equipment

Required: (1) Frequency counter

Procedure A:

1. Unsolder the brake coil lead (red) where it connects to TP-411 on the SV Board.
2. Set up the E-to-E mode.
3. Connect a frequency counter to TP-411.
4. Check the drum speed. The counter reading should be 30.25 Hz to 30.35 Hz.
5. If it is not correct, inspect the Rotary-Head-Drum Belt. Other causes of incorrect free-running speed should be referred to a SONY FACTORY SERVICE BRANCH.

6-2. VERTICAL SYNC SEPARATOR CHECK

The test checks the output of the sync separator.

Test Point/

Board: TP-404, TP-405, TP-406/SV

Check: Waveforms shown in Fig. 6-1.

Adjustment: None

Signal Source: Telecast signal

Equipment

Required: (1) Oscilloscope
(2) TV monitor

Procedure:

1. Set up the E-to-E mode using a telecast signal.
2. Connect the scope to TP-404, TP-405, and TP-406 and check that the waveforms shown in Fig. 6-1 are correct.

3. If they are incorrect, check and troubleshoot the sync separator circuit.

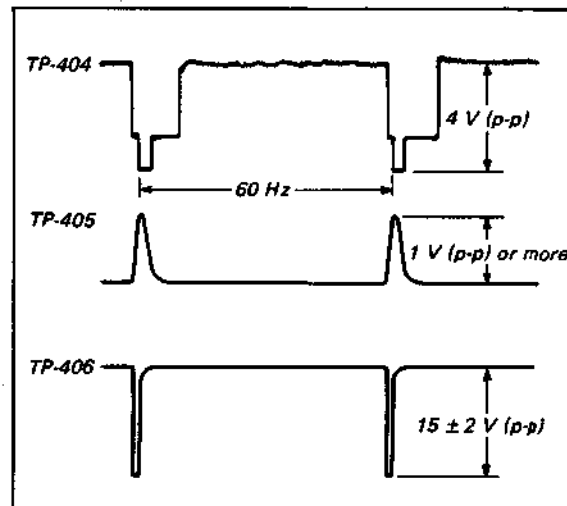

Fig. 6-1. Sync separator check

6-3. 2 : 1 FREQUENCY DIVIDER CHECK

Test Point/

Board: TP-407/SV (Separated sync pulse/ CTL pulse)

Adjust for: The waveform shown in Fig. 6-2.

Adjustment/

Board: R433/SV (30 Hz adjustment)

Signal Source: Telecast Signal

Equipment

Required: (1) Oscilloscope
(2) TV monitor

Procedure:

1. Set up the E-to-E mode using a telecast signal.
2. Connect the scope to TP-407.
3. Adjust R433 so that the interval "T" in Fig. 6-2 is 9 ± 1 msec.
4. Confirm that pulse amplitude is 15 ± 2 volts as shown in Fig. 6-2.

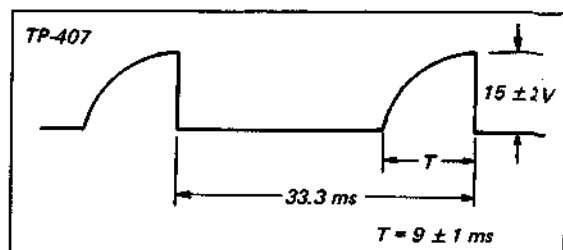

Fig. 6-2. Frequency divider check

6.4. 30-Hz PULSE ADJUSTMENT

This adjustment shapes the output of MM404 into a 50% duty cycle. Incorrect duty cycle may cause servo hunting or slow lock up.

Test Point/

Board: TP-409/SV (MV output)

Adjust for: 30-Hz pulse with a 50% duty cycle

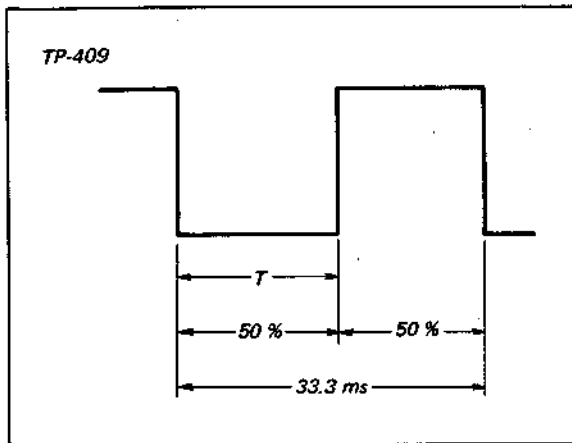

Fig. 6-3. 30-Hz pulse adjustment

Adjustment/

Board: R441/SV (Pulse Duty Cycle)

Signal Source: Telecast signal

Equipment

Required: (1) Oscilloscope
(2) TV monitor

Procedure:

1. Set up the E-to-E mode using a telecast signal.
2. Connect the scope to TP-409. Set the time base to 5 msec/cm.
3. Adjust R441 so that the interval "T" in Fig. 6-3 is 16.7 ± 0.5 msec, i.e., a duty cycle of 50%.

6.5. 30 PG PULSE LOCK PHASE ADJUSTMENT

This gain adjustment determines the location of the 30 PG feedback pulse on the 30 Hz MV output ramp.

Test Point/

Board: TP-410/SV (Integrated 30 Hz pulse)

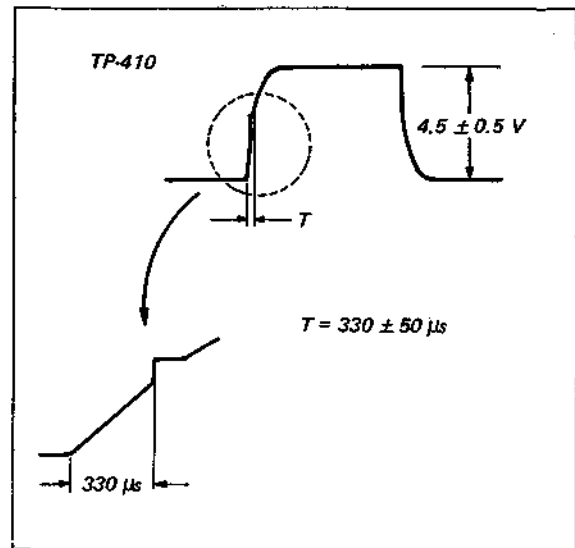

Fig. 6-4. Lock phase adjustment (REC/E-E mode)

Adjust for: See Fig. 6-4.

Adjustment/

Board: R454/SV (Lock Phase)

Signal Source: Telecast signal

Equipment

Required: (1) Oscilloscope
(2) TV monitor

Procedure:

1. Set up the E-to-E mode using a telecast signal
2. Connect the scope to TP-410.
3. Set the scope for 5 ms/cm horizontal sweep and pull out the 5X magnifier. Each division on the time-base now represents 1 msec.
4. Adjust the POSITION control on the scope to observe the interval "T" in Fig. 6-4.
5. Adjust R454 to set the position of the 30 PG pulse with respect to the 30 Hz multivibrator ramp as shown by "T" in Fig. 6-5.

6.6. SERVO RESPONSE-TIME ADJUSTMENT (Hunting)

Test Point/

Board: TP-410/SV (Integrated 30 PG pulse output)

Adjust for: Minimum lock-in time when the Videocorder is set to the REC/E-E mode from a complete stop.

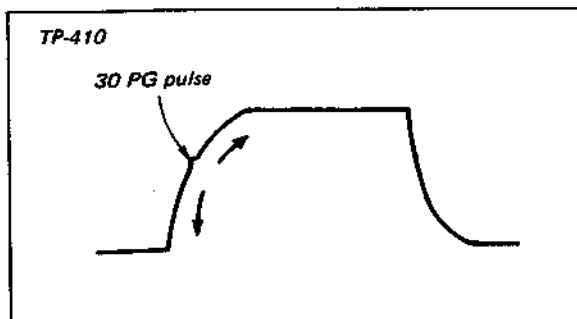

Fig. 6-5. Servo response-time adjustment

Adjustment/Board: R451/SV (Servo Response Time)
Signal Source: Telecast signal
Equipment Required: (1) Oscilloscope
 (2) TV monitor

Procedure:

1. Set up the E-to-E mode using a telecast signal.
2. Connect the scope to TP-410. Set the time base to 5 msec/cm.
3. Set the Function Lever to STOP (release the RECORD button) and wait until the rotating head stops turning completely. Then, depress the RECORD button. Observe the waveform on the scope. The PG pulse will move up and down a few times and then lock on the 30 Hz multivibrator ramp as shown in Fig. 6-5.
4. Adjust R451 for minimum lock-in time without hunting. Repeat Step 3 after each adjustment of R451.

Note: Clockwise rotation of R451 shortens the lock-in time, but increases hunting. Counterclockwise rotation decreases hunting but lengthens lock-in time.

6-7. PLAYBACK SERVO CHECK

Check that the correct CTL (Control track) pulses are reproduced for the servo system in the Playback mode.

Test Point/Board: TP-406/SV (CTL pulse output)
Check: Waveforms in Fig. 6-6.

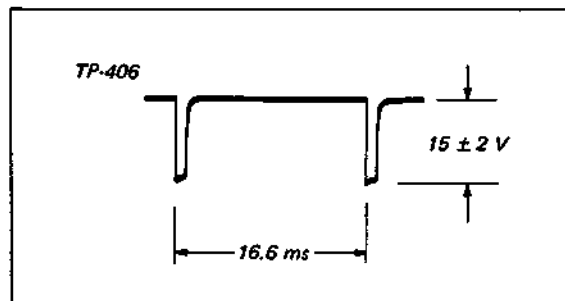

Fig. 6-6. Control track pulse check

Adjustment: None
Signal Source: Telecast Signal
Equipment Required: (1) Oscilloscope
 (2) TV monitor

Procedure:

1. Make a recording of a telecast signal.
2. Play back the tape.
3. Connect the scope to TP-406 and check the waveform shown in Fig. 6-6.
4. Confirm that the picture locks up correctly in the Playback mode. If the servo system does not stabilize, troubleshoot the CTL pulse amplifying circuits.

The following adjustments in Secs. 6-8 and 6-9 are necessary only when either one of 30 PG coils has been replaced or repositioned.

6-8. 30 PG PULSE POSITION CHECK (30 PG Coil Position)

Correct coil positions ensure proper switching between video heads, and also ensure switching at the proper time with respect to vertical sync.

CAUTION

Avoid adjustment of 30 PG coils unless tests indicate that adjustment must be made.

Test Point/Board: TP-304/V1 (Video signal output)

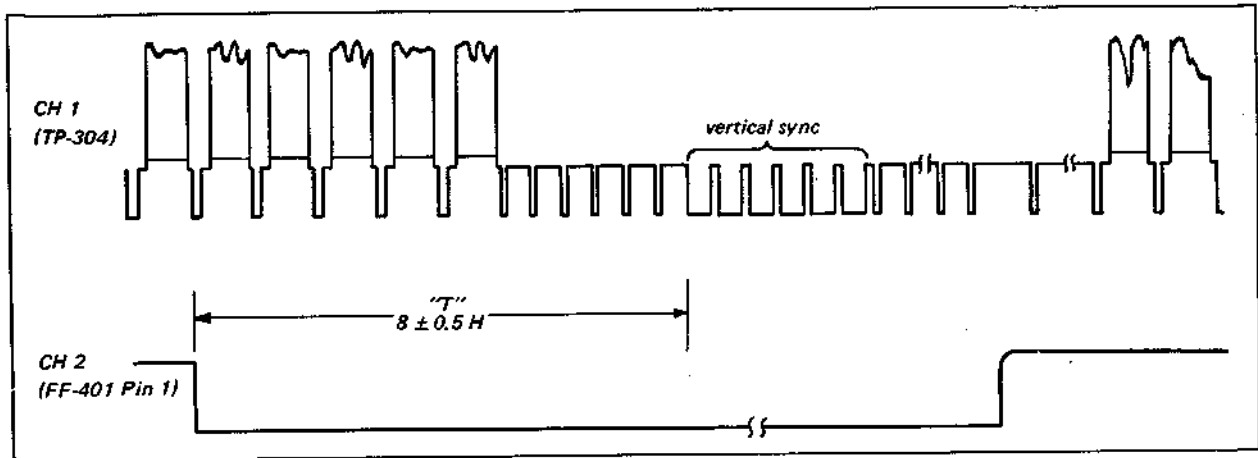

Fig. 6-7. 30 PG coil position

FF-401 Pin 1/SV (Wave-shaped 30 PG output)

Check: 8 ± 0.5 H phase difference
See Fig. 6-7

Adjustment: 30 PG Coil A

Signal Source: Alignment Tape

Equipment Required: (1) Oscilloscope
(2) SONY Alignment Tape

Procedure:

1. Play back the SONY Alignment Tape.
2. Connect a dual-trace scope CH-1 probe to TP-304 and CH-2 probe to Pin 1 of FF401
Set the time base to 2 ms/cm and the MODE select switch to CHOP.
3. Sync the scope externally from TP-403.
4. Pull out the 5X magnifier and adjust the POSITION control to observe the second vertical blanking interval as shown in Fig. 6-7.
5. Check that the interval "T" shown in Fig. 6-7 is 8 ± 0.5 H (horizontal lines).
6. If it is correct, proceed to the "30 PG PULSE PHASE CHECK" in Sec. 6-9. If it is not correct, reposition 30 PG Coil A, which is mounted at the front of the scanner, at the six o'clock position. See Fig. 6-8. Be sure the motor is off when making this adjustment. Proceed as follows.
7. Stop the motor (release the RECORD button) and allow the heads to stop turning.
8. Loosen the screw securing 30 PG Coil A, and

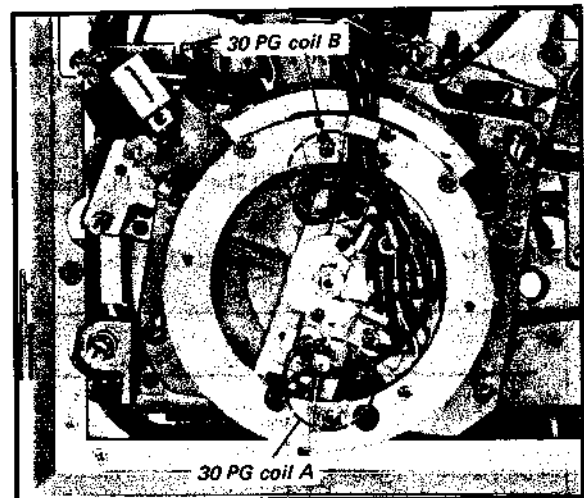

Fig. 6-8. 30 PG Coils A and B

reposition the coil. If "T" in Fig. 6-7 is more than 8 ± 0.5 H, move the coil slightly to the left (in the direction of scanner rotation). If "T" is less than 8 ± 0.5 H, move the coil to the right. Be very careful when adjusting coil position. Make sure that the gap between the coil poles and the rotating pole piece remains the same. Also, make sure that the coil poles and the rotating pole pieces line up when viewed from above.

9. Before turning on the motor again, rotate the video heads by hand to check that the pole piece clears both 30 PG coils.
10. Start the motor again and check the waveform.
11. Repeat Steps 5 to 10 until the interval "T" of 8 ± 0.5 H is achieved.

Interaction:

This adjustment may interact with those described in Sections 6-5, 6-9, and 6-11. Whenever 30 PG coil A is adjusted, check and, if necessary, readjust these sections.

6-9. 30 PG PULSE PHASE CHECK

This procedure sets up the precise angular displacement between the two 30 PG coils. One 30 PG coil should be exactly 180° from the other. When properly adjusted, correct interlace is achieved in the playback picture and vertical jitter is minimized. This adjustment follows "30 PG Pulse Position Check" in Sec. 6-8.

CAUTION

Avoid adjustment of the 30 PG coil unless tests indicate that the adjustment must be made.

Test Point/

Board: TP-412/SV (Shaped 30 PG pulse output)

Adjust for: Minimum phase difference

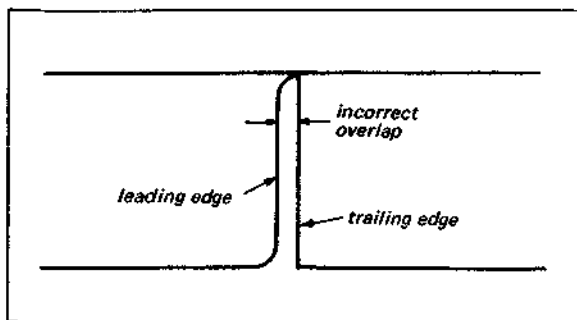

Fig. 6-9. 30 PG Pulse phase Check

Adjustment: 30 PG Coil B

Signal Source: Telecast Signal

Equipment

Required: (1) Oscilloscope
(2) TV monitor

Procedure:

1. Set up the E-to-E mode using a telecast signal.
2. Connect the scope to TP-412.
3. Sync the scope externally from TP-406. Set the time base to 5 ms/cm.

4. Turn the VARIABLE control of the scopes time-base counterclockwise (from the CALIBRATED to the UNCALIBRATED) until two pulses can be seen at the same time on the scope.
5. Pull out the 5X magnifier and adjust the HORIZONTAL POSITION control to observe the leading edge of either pulse. See Fig. 6-9.
6. Check that the leading edge of a pulse does not overlap the trailing edge of the previous pulse.
7. If it does reposition 30 PG coil B as follows.
8. Stop the motor (release the RECORD button). Allow the heads to stop turning.
9. Loosen the screw securing 30 PG coil B, which is mounted at the rear of the scanner, at the 12 o'clock position. See Fig. 6-8.
10. Move 30 PG Coil B slightly to the left or right.
11. Start the motor again and check the waveform in Fig. 6-9.
12. Repeat Steps 8 to 11 until the correct condition is obtained.

6-10. SERVO-REFERENCE DELAY MV (REC)

The servo-reference delay multivibrator (MM40 1) adjusts the precise angular position of heads with reference to the vertical sync pulse.

Test Point/

Board: TP-403/SV (Delayed 30 PG pulse output)

Adjust for: A pulse width of 930 μsec. See Fig. 6-10.

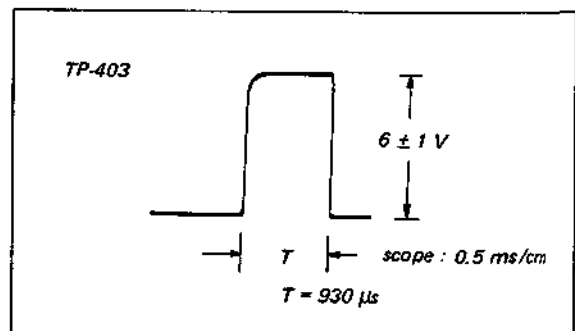

Fig. 6-10. Delay multivibrator adjustment (REC mode)

Adjustment/

Board: R413/SV (Lock Phase)

Signal Source: Telecast signal

Equipment

- Required:** (1) Oscilloscope
(2) TV monitor

Procedure:

1. Set up the E-to-E mode using a telecast signal.
2. Connect the scope to TP-403.
3. Adjust R413 to obtain the pulse width (T) of 930 μ sec as shown in Fig. 6-10.
4. Confirm that the pulse amplitude is 6 ± 1 V. If it is not, and the servo system does not stabilize, check MM401 and, if necessary, replace it.

6-11. SERVO-REFERENCE DELAY MV(PB)

The servo-reference delay multivibrator adjusts the precise angular position of the heads with reference to the playback video signal in the Playback mode.

Test Point/

Board: TP-403/SV (Delayed 30 PG pulse output)

Adjust for: A pulse width of 1.9 msec. See Fig. 6-11.

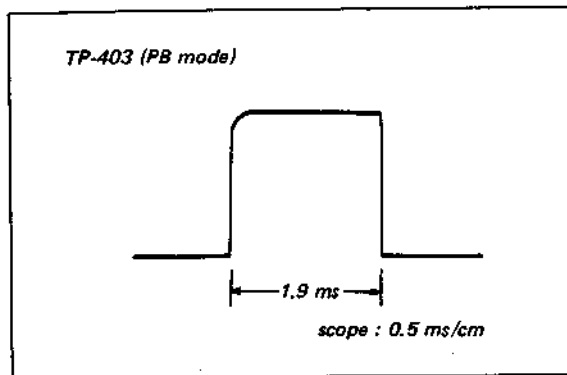

Fig. 6-11. Delay multivibrator adjustment (PB mode)

Adjustment/

Board: R412/SV (Lock Phase)

Signal Source: Telecast signal

Equipment

- Required:** (1) Oscilloscope
(2) TV monitor

Procedure:

1. Make a recording of a telecast signal.
2. Play back the tape.
3. Connect the scope to TP-403.
4. Adjust R412 (PB Lock Phase) to produce 1.9 ms pulse width as shown in Fig. 6-11.

6-12. TRACKING CONTROL CHECK

This test checks the range of the variable tracking control.

Test Point/

Board: TP-408/SV (Tracking MV output)

Check: See Fig. 6-12.

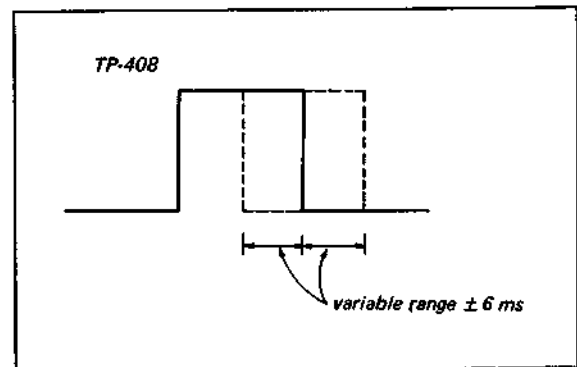

Fig. 6-12. Tracking control check

Adjustments: R007 (TRACKING control)/Control Panel

Signal Source: Telecast signal

Equipment

- Required:** (1) Oscilloscope
(2) Blank tape
(3) TV monitor

Procedure:

1. Make a recording of a telecast signal.
2. Play back the tape.
3. Connect the scope to TP-408
Set the time base to 2 msec/cm.
4. Pull and turn the TRACKING control (R007) and confirm that the output pulse shifts ± 6 msec as shown in Fig. 6-12.

5. If it does not, change R007 from 100 k Ω to 200 k Ω .

6-13. VERTICAL SYNC FORMER CHECK

Test Point: 6-Pin CAMERA Receptacle

Check: Waveform shown in Fig. 6-13.

Adjustment: None

Signal Source: None required

Equipment Required: Oscilloscope

Procedure:

1. Turn on the Videocorder with or without an input signal.
2. Connect a 75-ohm resistor between Pin 2 and Pin 6 of the 6-pin CAMERA receptacle.
3. Connect the scope to Pin 2.
4. Check that the output is as shown in Fig. 6-13.
5. If it is not, check and troubleshoot the SY3 Board mounted behind the connector panel.

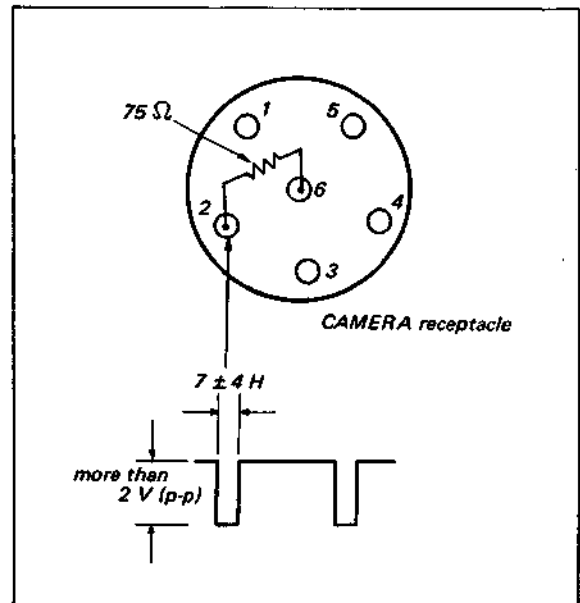

Fig. 6-13. Vertical sync for camera

SECTION 7

AUDIO SYSTEM ALIGNMENT

The audio system alignment procedure and sequence is shown in Chart 7-1.

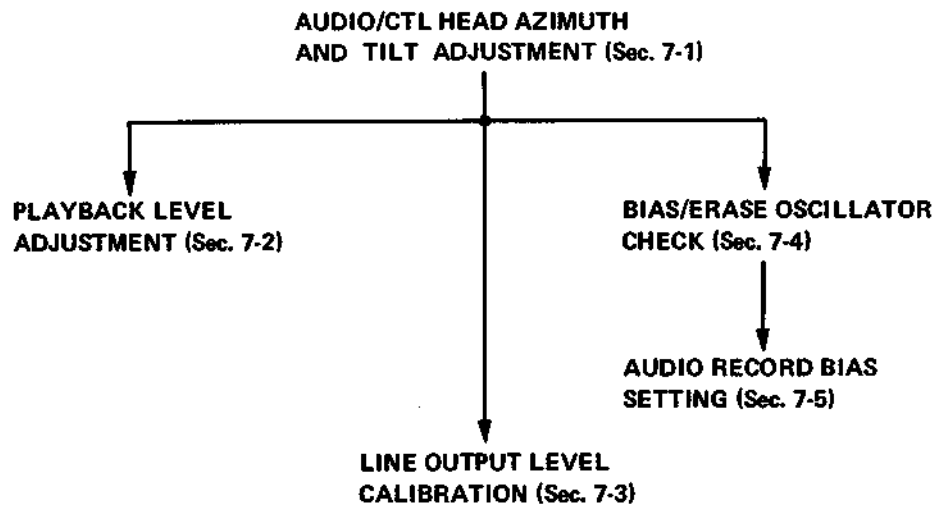

Chart 7-1. Audio system alignment

7-1. AUDIO/CTL HEAD AZIMUTH AND TILT ADJUSTMENTS

Test Point: TP-502 (Audio Output)

Adjust for: Maximum output reading on VTVM

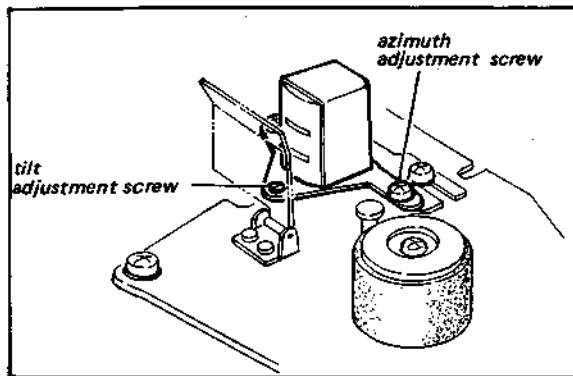

Fig. 7-1. Audio/CTL head azimuth and tilt adjustments

Adjustment: Azimuth and tilt adjustment screws

Signal Source: 7 kHz audio signal of SONY Alignment Tape

Equipment Required:
 (1) AC VTVM
 (2) SONY Alignment Tape

Procedure:

1. Play back the SONY Alignment Tape.
2. Connect a VTVM to TP-502.
3. Adjust azimuth and tilt for maximum indication on the VTVM using the 7 kHz tone. See Fig. 7-1.

7-2. PLAYBACK LEVEL ADJUSTMENT

Test Point: TP-502 (Audio Output)

Adjust for: 0 dB (0.775V) output

Adjustment: R515 (PB Level)

Equipment Required:
 (1) AC VTVM
 (2) SONY Alignment Tape
 (3) 100 kΩ resistor

Set-up : See Fig. 7-2.

Procedure:

1. Connect the ac VTVM to TP-502 using a 100 kΩ load resistor as shown in Fig. 7-2.

2. Play back the SONY Alignment Tape (1 kHz tone).

3. Adjust R515 (Playback Level) to obtain a reading of 0 dB (0.755 V) on the VTVM.

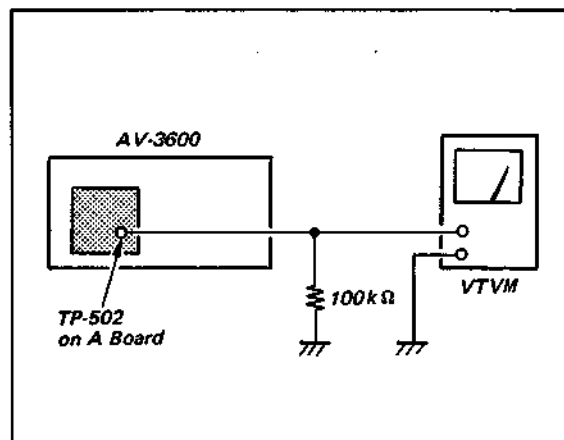

Fig. 7-2. Audio playback level and frequency response adjustment set-up

7-3. LINE OUTPUT LEVEL (Record mode; Record Level) CALIBRATION

Test Point: TP-502 (Line Output)

Adjust for: 0.775 V (0 dB) at TP-502 for 0.4 mV (-65 dB) MIC input

Adjustment: R521 (Line Output level, Record)

Signal Source: 1 kHz audio signal

Equipment Required:
 (1) AC VTVM
 (2) Audio oscillator
 (3) Attenuator
 (4) 100 kΩ load resistor

Set-up: See Fig. 7-3.

Procedure:

1. Connect the VTVM to TP-502 using a 100 kΩ load resistor as shown in Fig. 7-3.
2. Connect the audio oscillator and the attenuator as shown.
3. Set up the E-to-E mode.
4. Feed a 1 kHz signal of -65 dB (0.4 mV) to the MIC IN jack.
5. Adjust R521 (Line Output Level) to obtain a VTVM reading of 0 dB (0.775 V).

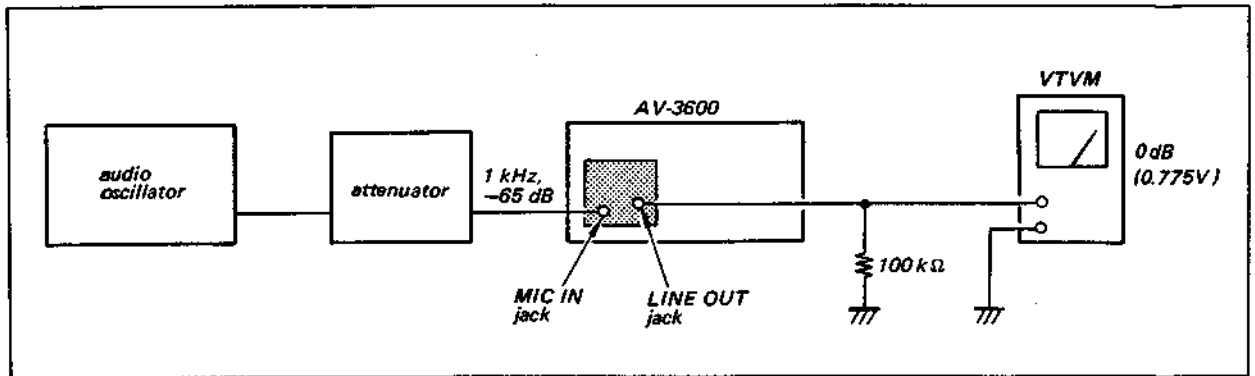

Fig. 7-3. Record level calibration set-up

7-4. BIAS/ERASE OSCILLATOR CHECK

Test Point: TP-503 (Erase Osc Output)

Check: 270 V (p-p)

Adjustment: None

Signal Source: None required

Equipment

Required: Oscilloscope

Procedure:

1. Set up the Record mode.
2. Connect the scope to TP-503.
3. The scope should indicate more than 270 V (p-p). Also, make sure that the frequency is between 80 kHz and 100 kHz (12.5 μ s and 10 μ s).
4. If the scope waveform does not conform to rated specifications, check and troubleshoot the erase oscillator circuit.

7-5. AUDIO RECORD BIAS SETTING

Test Point: TP-504 (Audio Head Input/Output)

Adjust for: 22 volts.

Adjustment: C532 (Bias), L401 (Dummy Coil)

Signal Source: None required

Equipment

Required: (1) AC VTVM
(2) Blank tape

Procedure:

1. Thread the tape and set up the Record mode with no input signal.
2. Connect the ac VTVM to TP-504.
3. Adjust C532 (Bias) to produce a 22 volt rms reading on the VTVM.
4. Play back the tape.
5. Set up the Audio Dub mode.
6. Adjust L401 (at the top center on the SV Board) for the same reading as that in Step 3.

SECTION 8

POWER SUPPLY ALIGNMENT

8-1. POWER SUPPLY ADJUSTMENT

Test Point: TP-601

Adjust for: +28V dc

Adjustment: R604 (B+ SET)

Signal Source: None required

Equipment

- Required:*
- (1) VOM
 - (2) Variac or adjustable transformer

Procedure:

1. Set the ac input voltage to 117 volts, using the Variac or adjustable transformer.
2. Connect the VOM between TP-601 and ground.
3. Adjust R604 for a reading of 28 volts dc.

(For Sets bearing Serial No. 12,201 and higher)*

4. Connect the VOM between TP-602 and ground.

5. Adjust R610 for a reading of 9 volts dc.

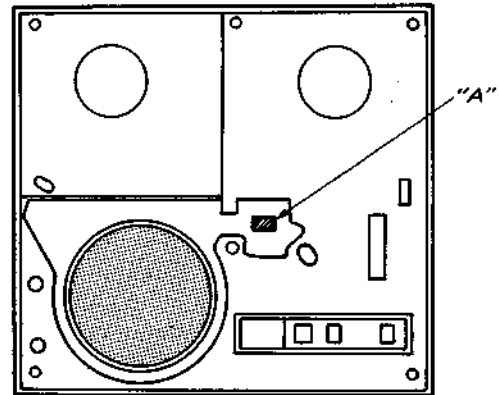

Fig. 8-1. A chassis mark

* These sets are identified by the letter "A" stamped on the chassis as shown.

SECTION 9

PRINTED CIRCUIT BOARD AND SCHEMATIC DIAGRAMS

Semiconductor Electrodes

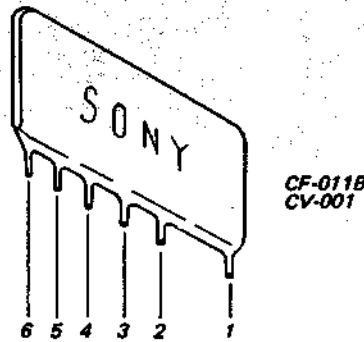
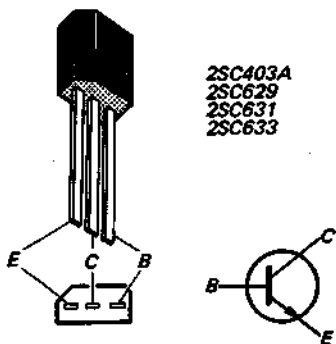
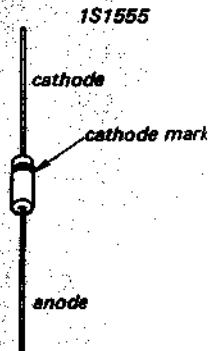
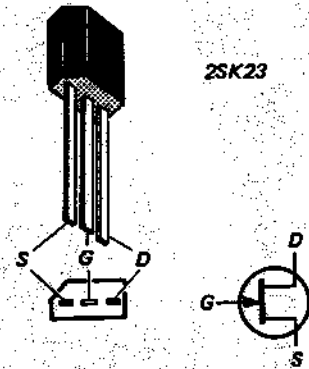
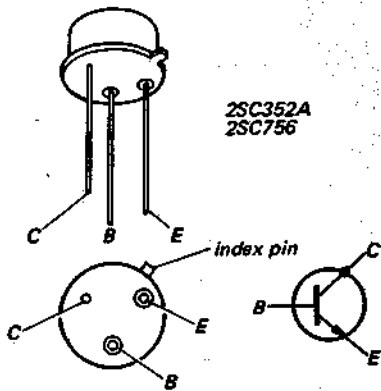
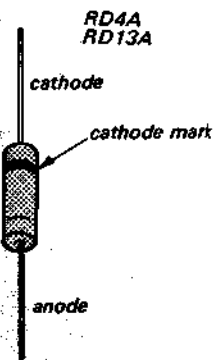
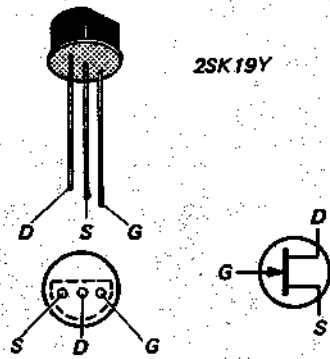
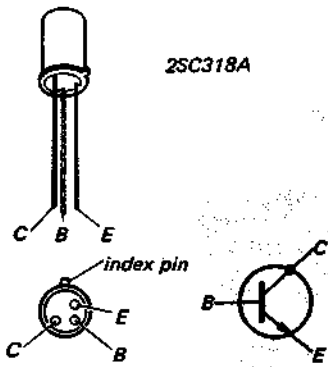
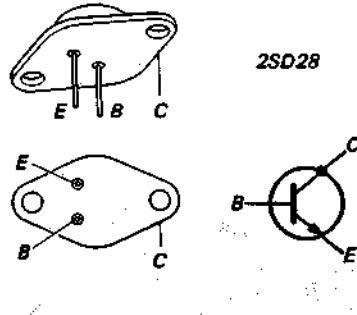
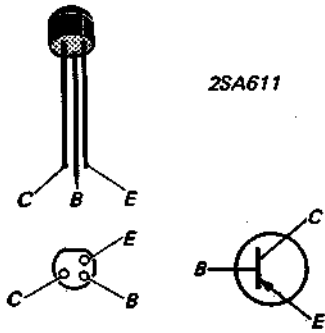

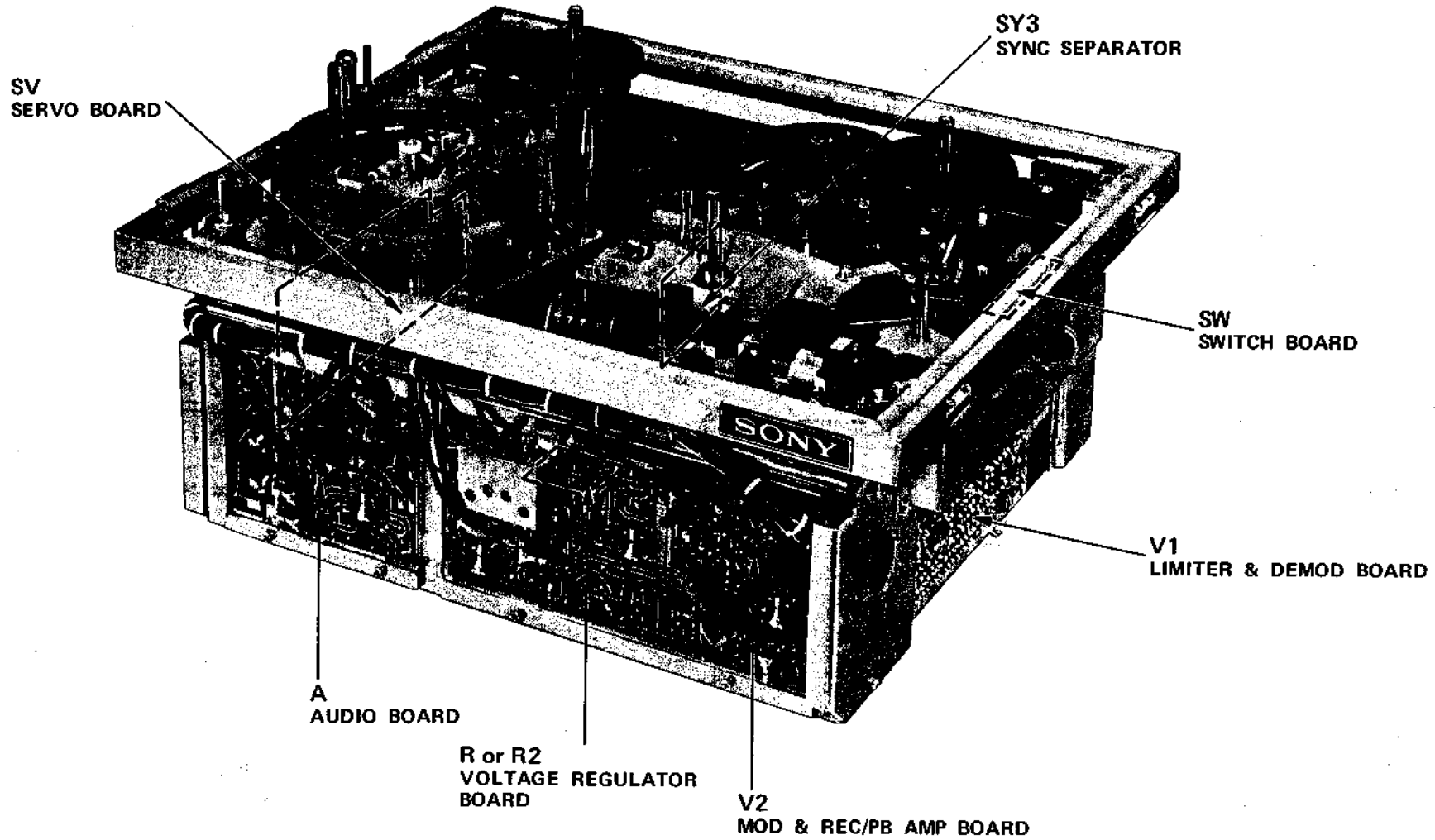

9-1. V2 MOD & REC/PB AMP PRINTED CIRCUIT BOARD - CONDUCTOR SIDE

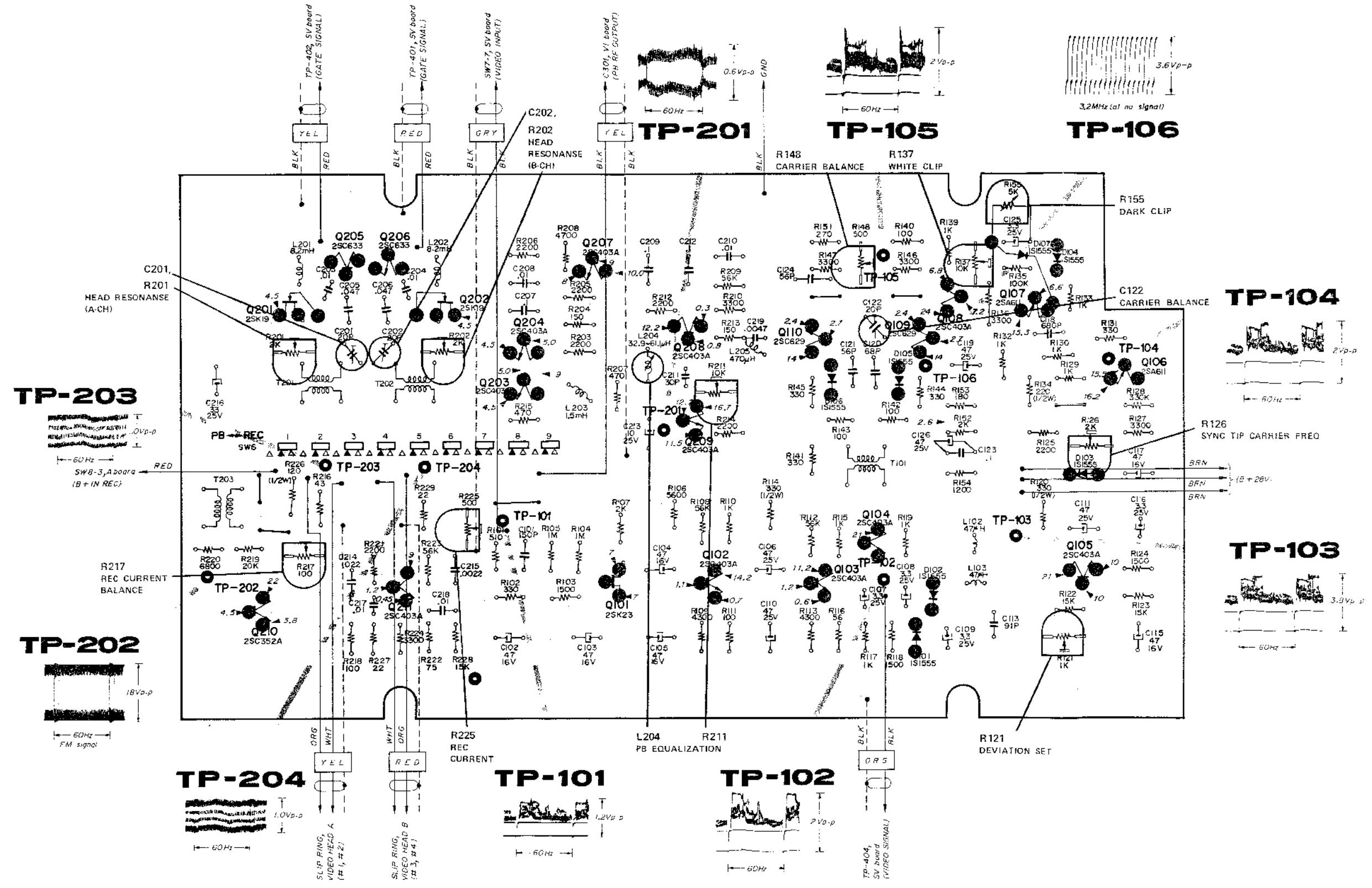

V2 MOD & REC/PB AMP PRINTED CIRCUIT BOARD - COMPONENT SIDE

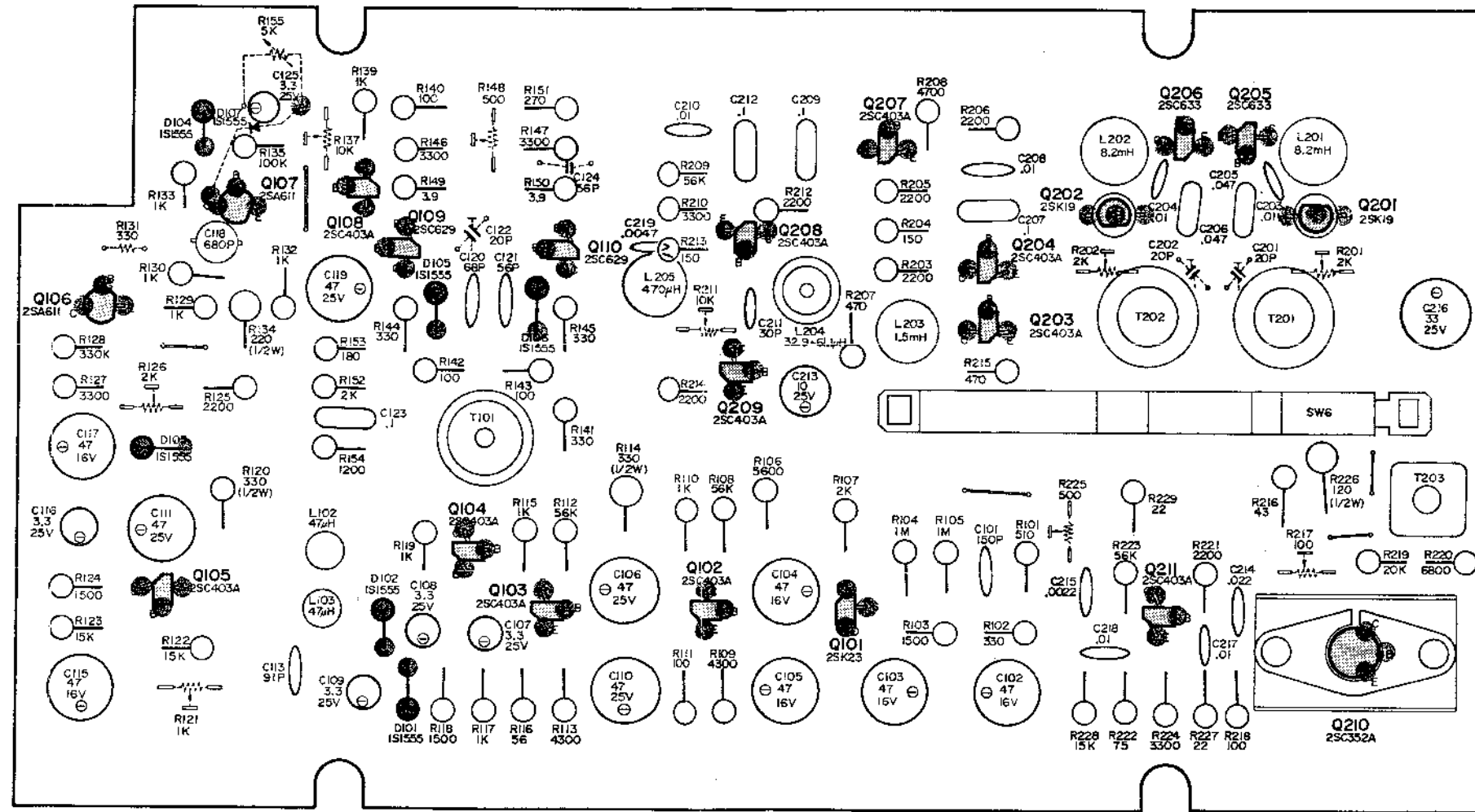

9-2. V1 LIMITER & DEMOD PRINTED CIRCUIT BOARD - CONDUCTOR SIDE

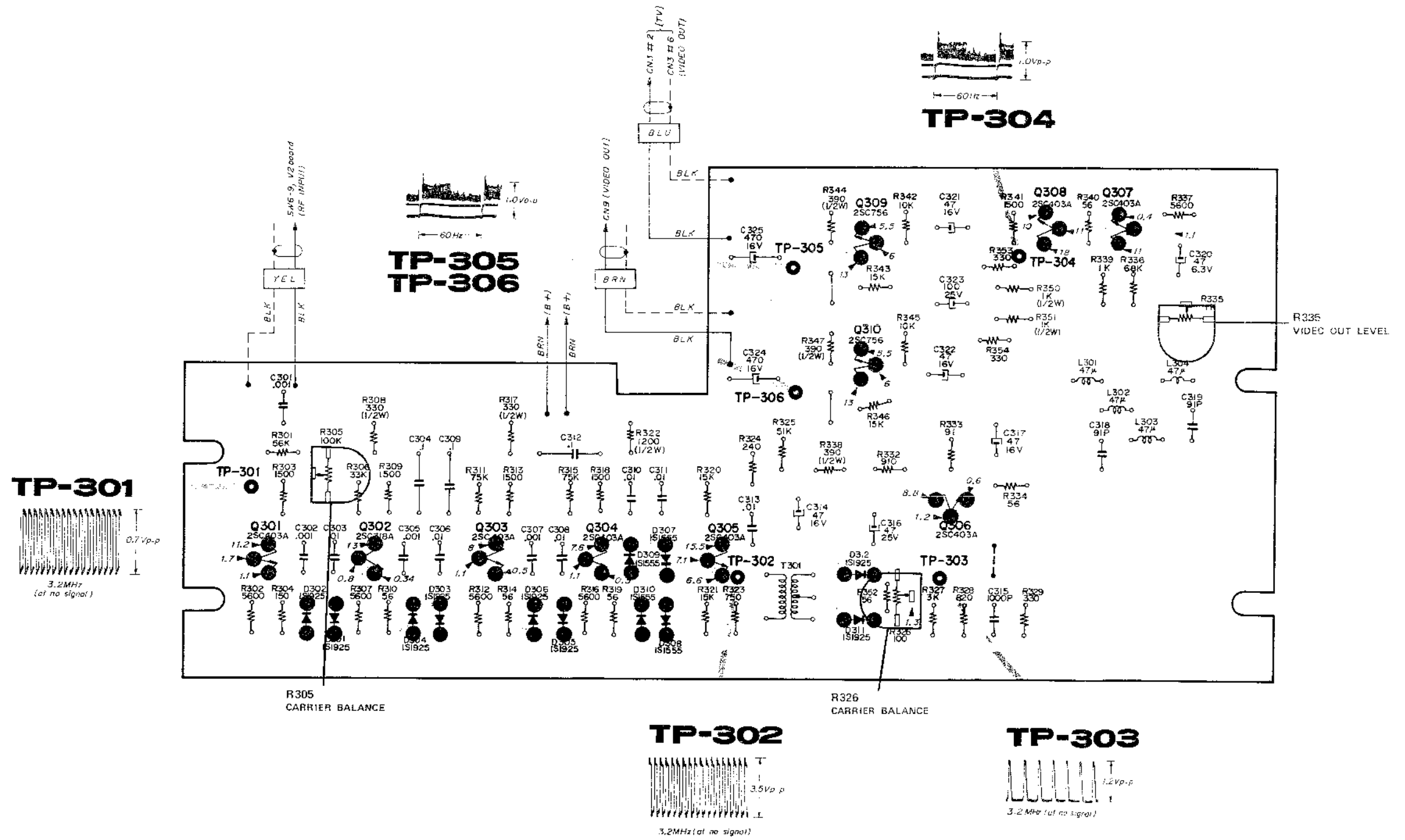

V1 LIMITER & DEMOD PRINTED CIRCUIT BOARD - COMPONENT SIDE

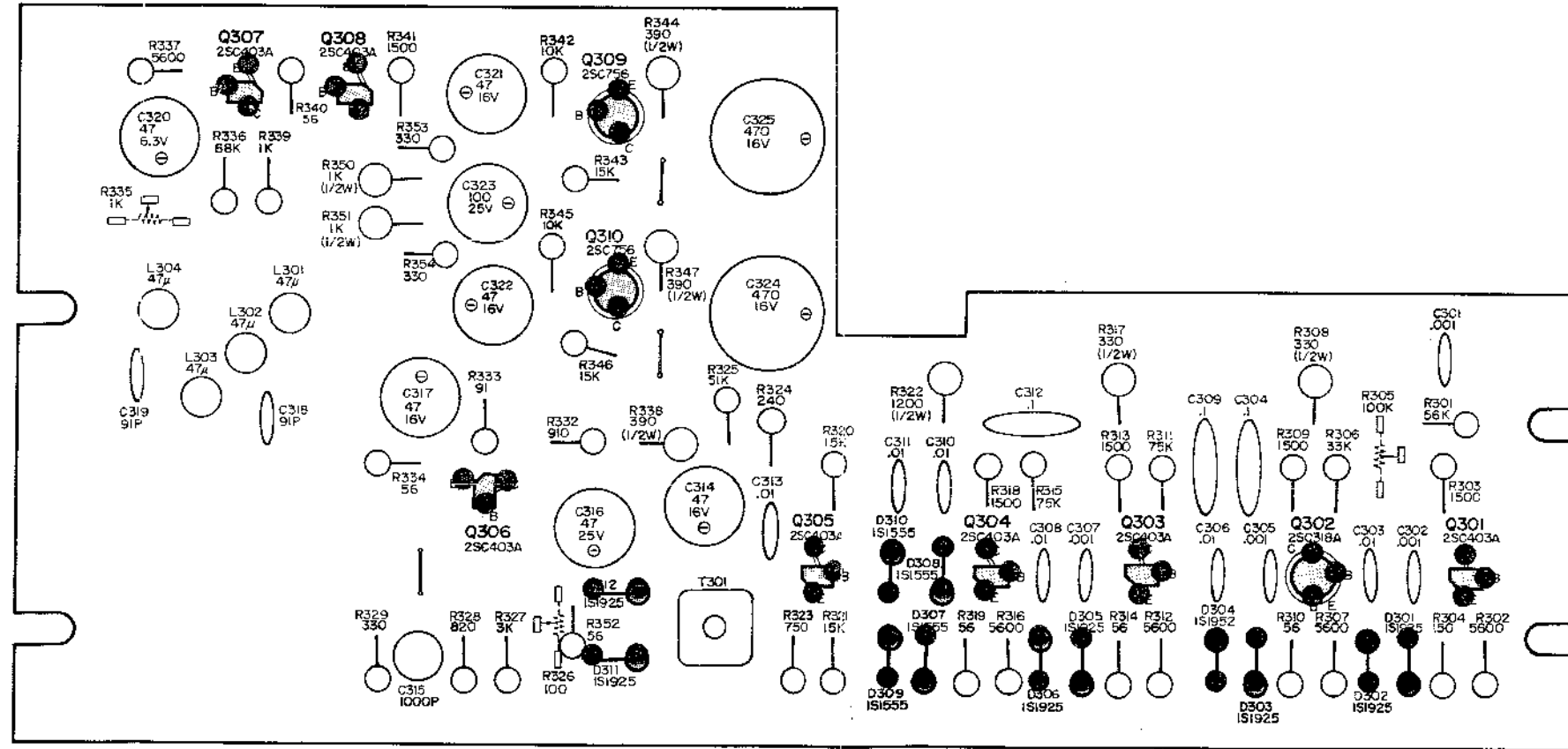

9.3. SV SERVO PRINTED CIRCUIT BOARD - CONDUCTOR SIDE

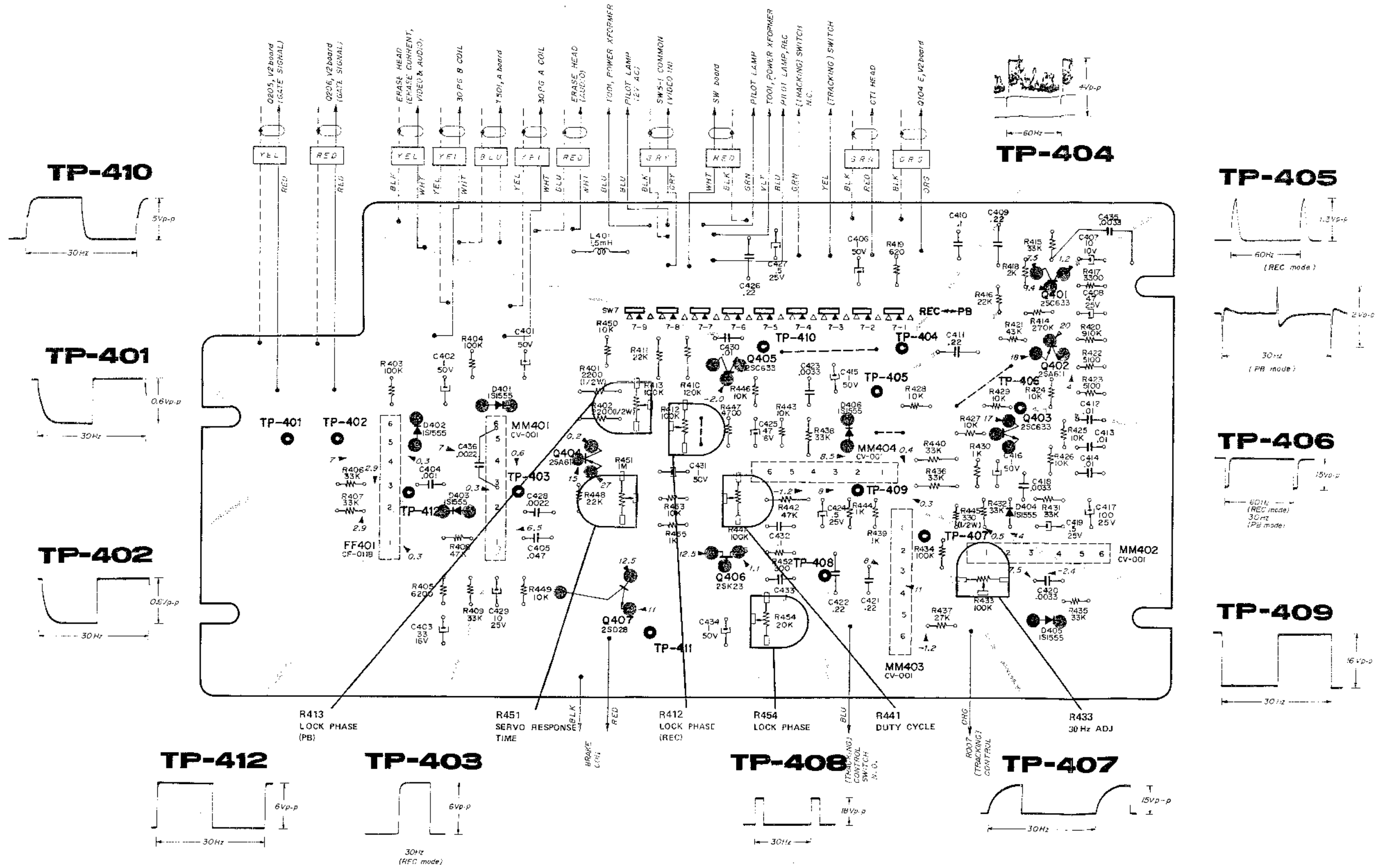

SV SERVO PRINTED CIRCUIT BOARD - COMPONENT SIDE

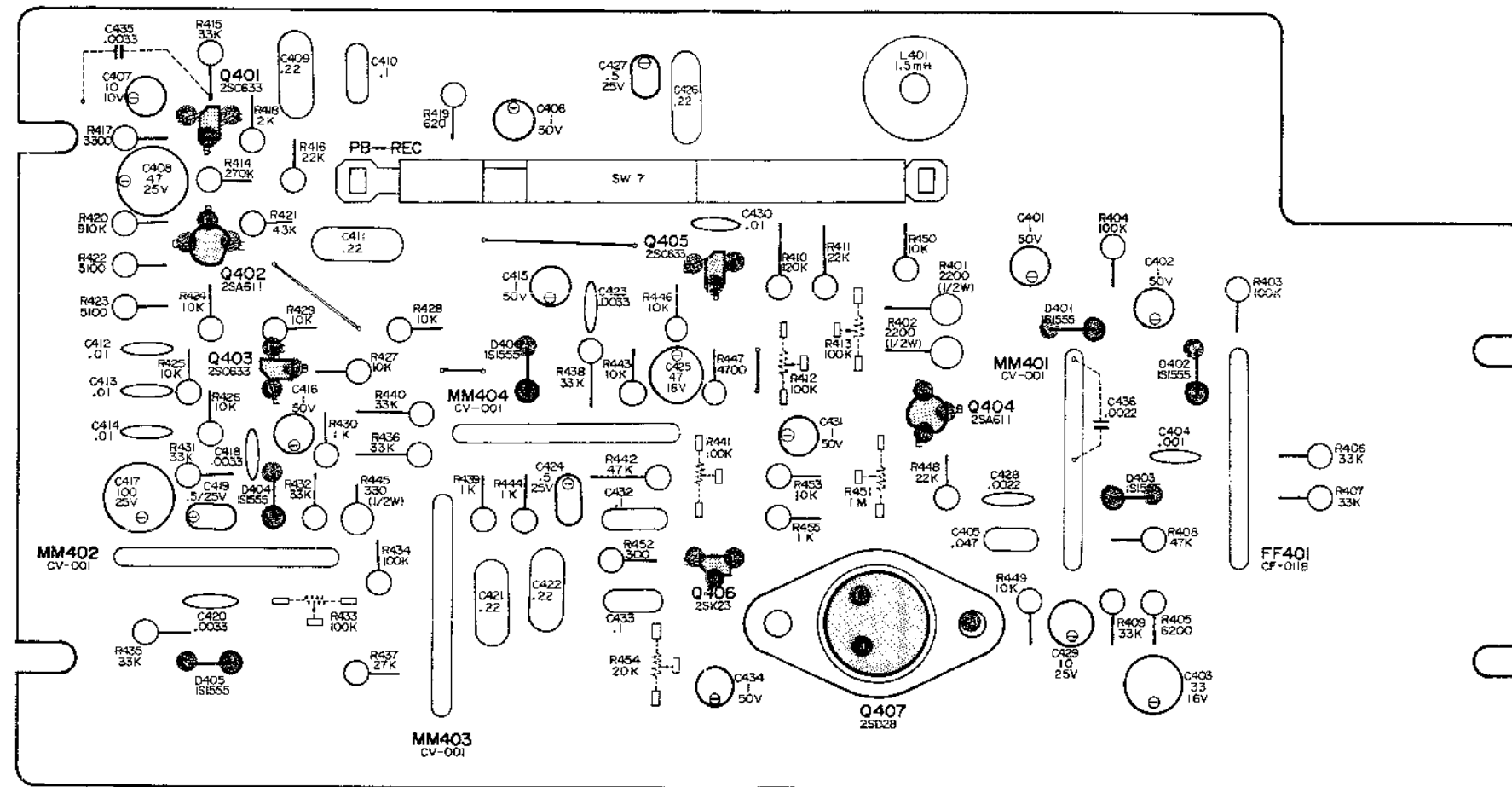

A AUDIO PRINTED CIRCUIT BOARD - COMPONENT SIDE

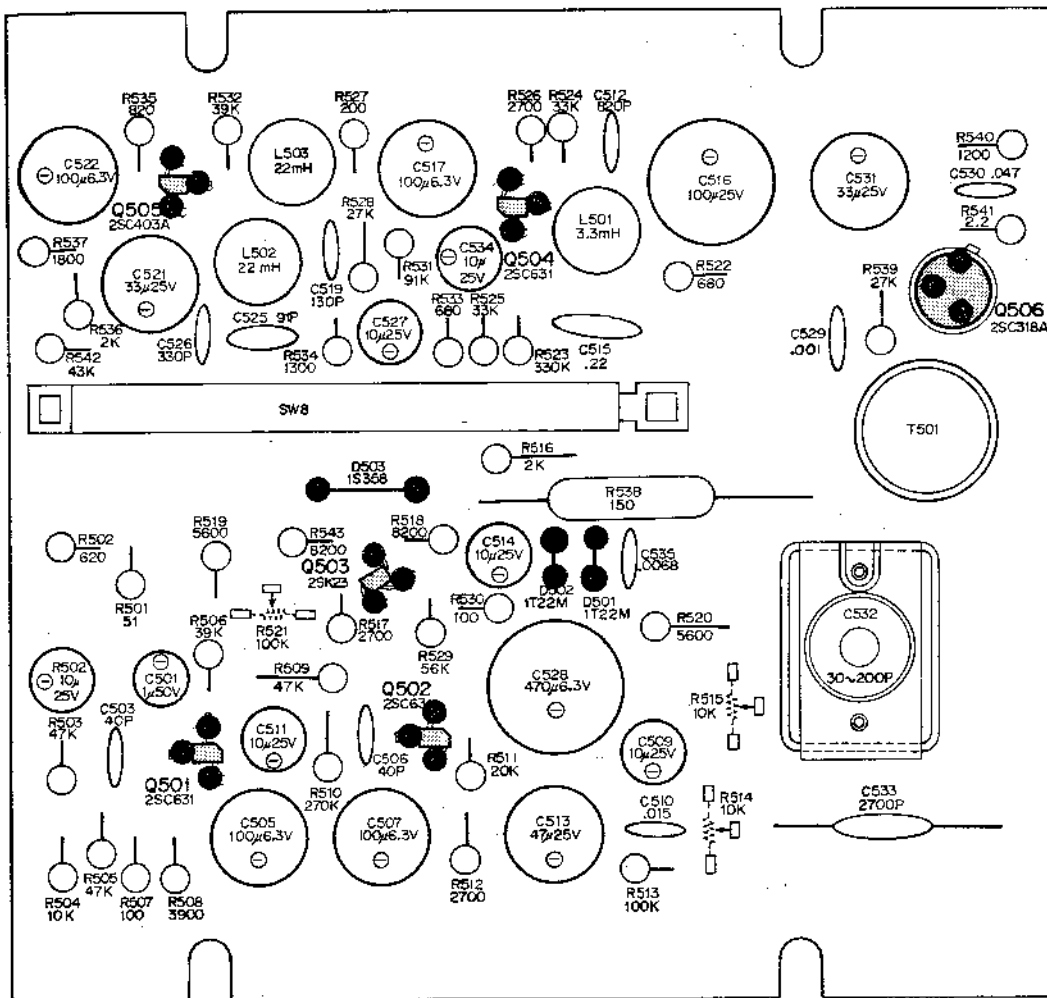

9.4. A AUDIO PRINTED CIRCUIT BOARD – CONDUCTOR SIDE

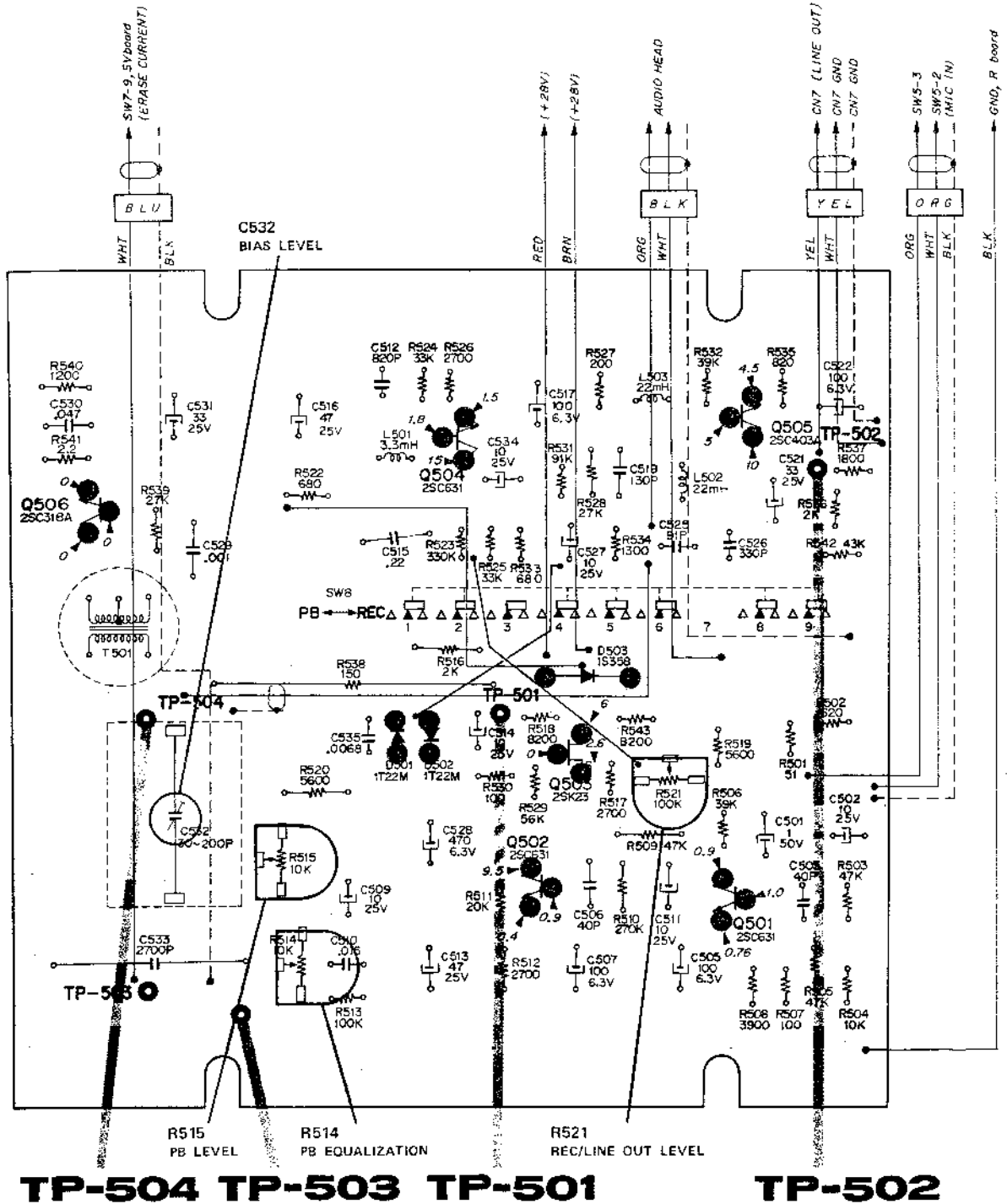

TP-504 TP-503 TP-501 TP-502

9-5. R2 VOLTAGE REGULATOR PRINTED CIRCUIT BOARD – CONDUCTOR SIDE
 (Serial number 12,201 and higher)

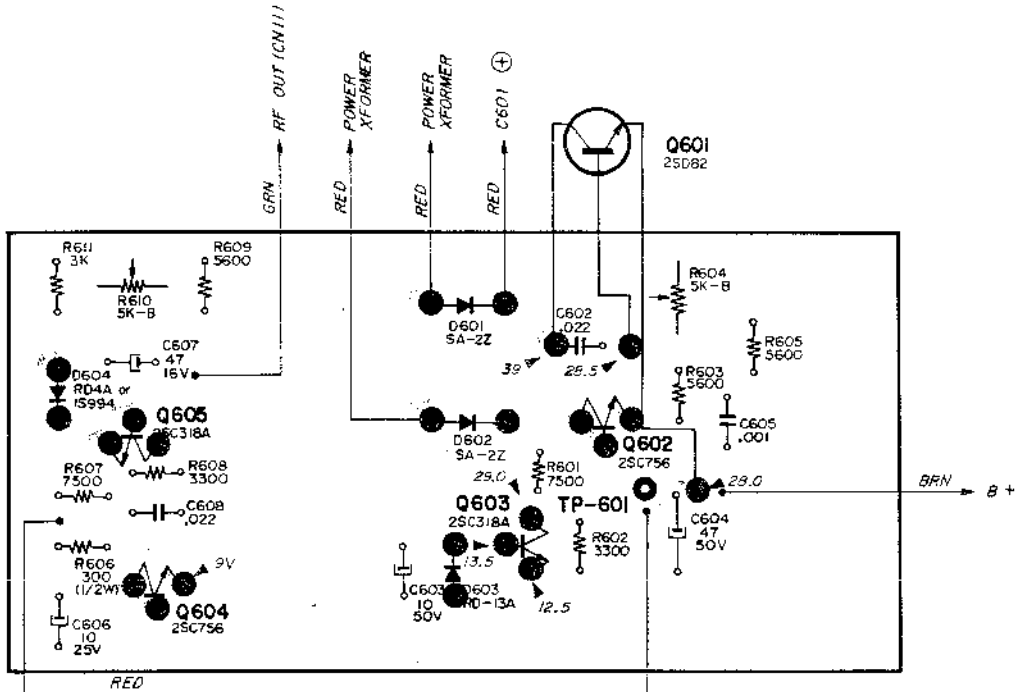

R VOLTAGE REGULATOR PRINTED CIRCUIT BOARD – CONDUCTOR SIDE
 (Serial number up to 12,200)

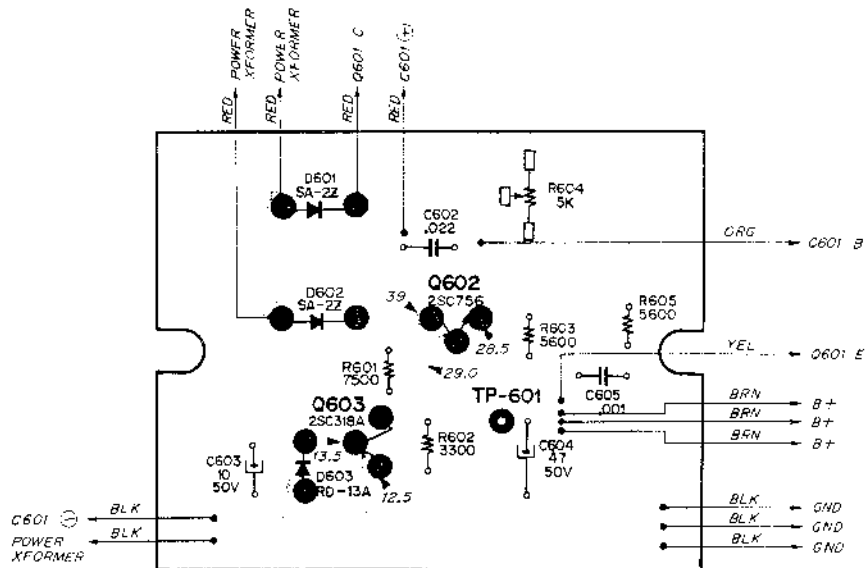

R2 VOLTAGE REGULATOR PRINTED CIRCUIT BOARD – COMPONENT SIDE
(Serial number 12,201 and higher)

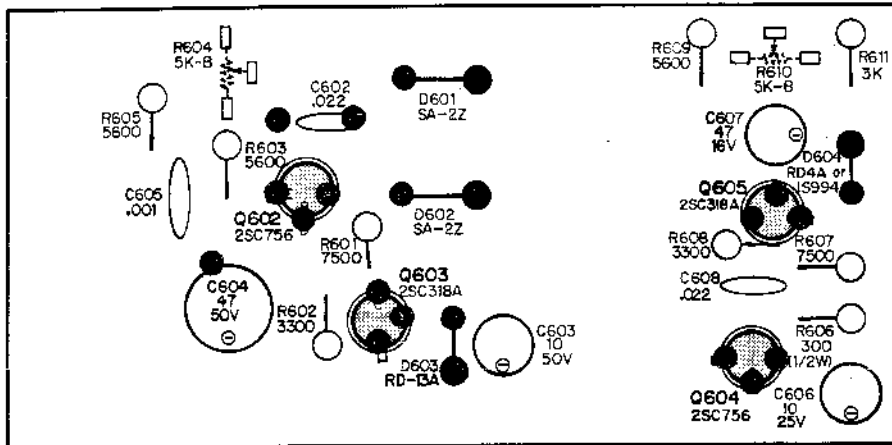

R VOLTAGE REGULATOR PRINTED CIRCUIT BOARD – COMPONENT SIDE
(Serial number up to 12,200)

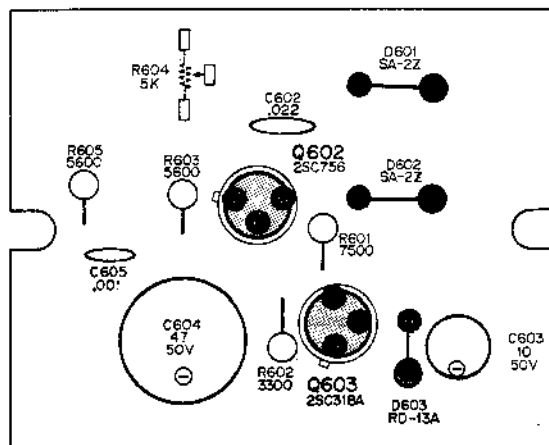

9-6. SY3 VERTICAL SYNC FORMER PRINTED CIRCUIT BOARD - CONDUCTOR SIDE

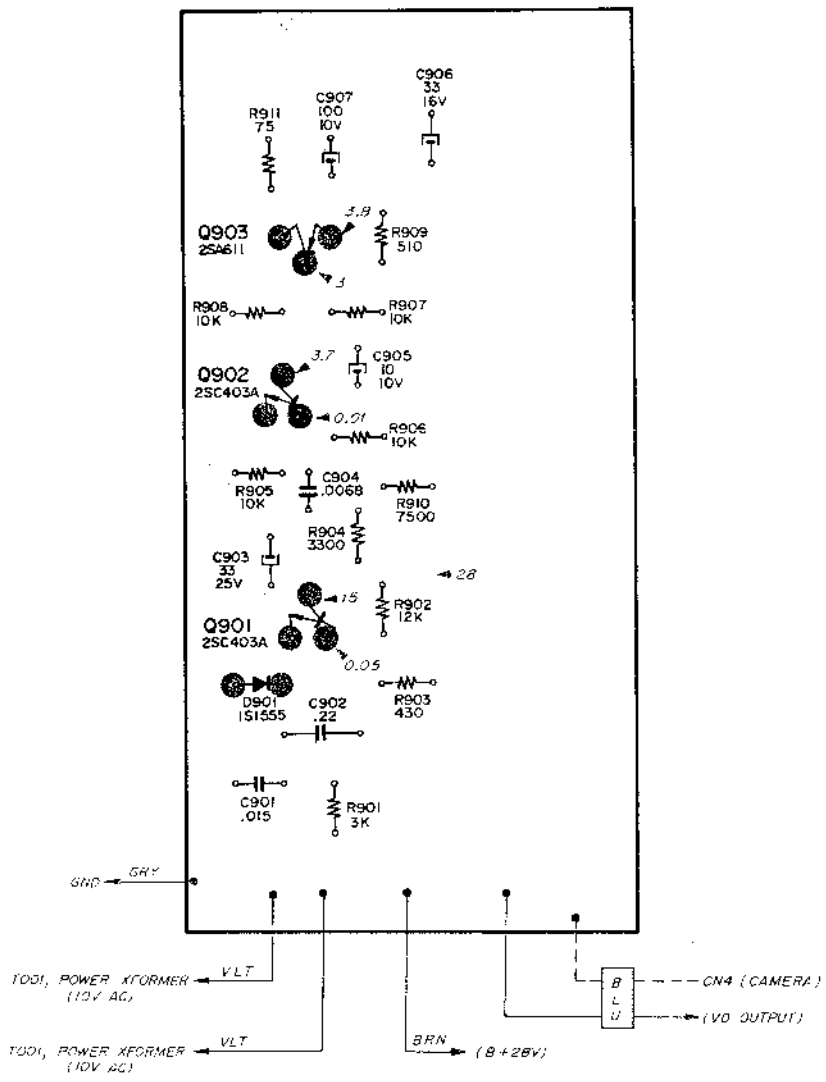

SY3 VERTICAL SYNC FORMER PRINTED CIRCUIT BOARD - COMPONENT SIDE

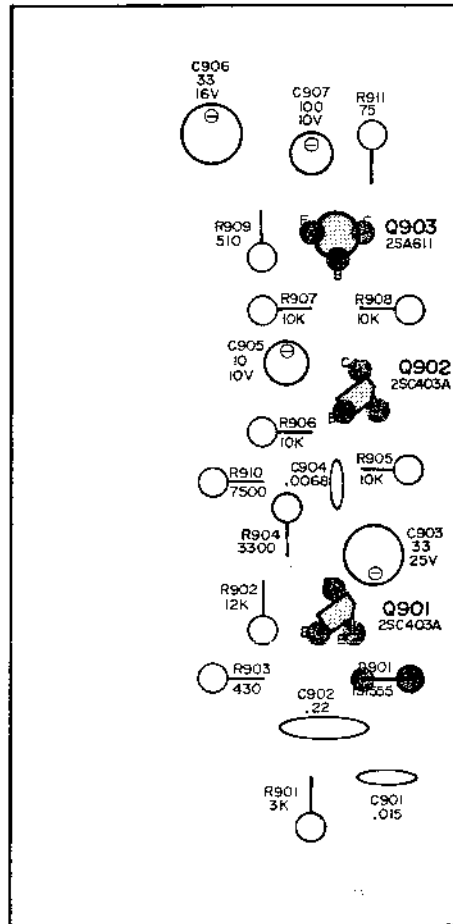

SW SWITCH BOARD

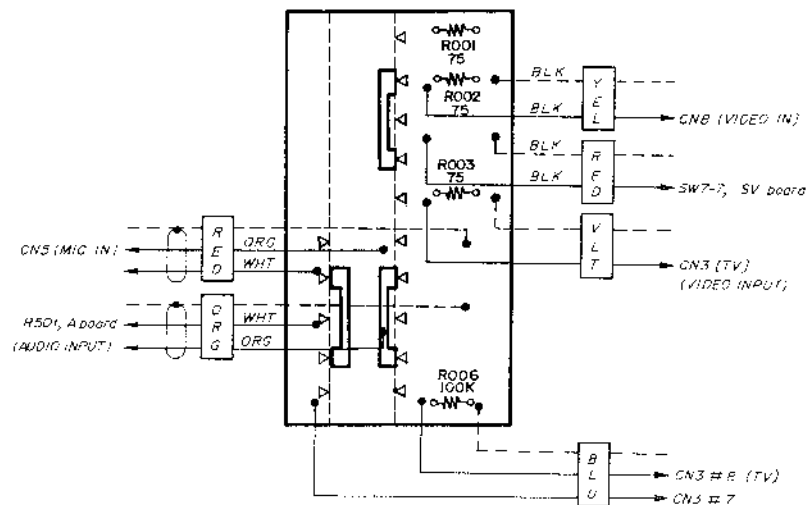

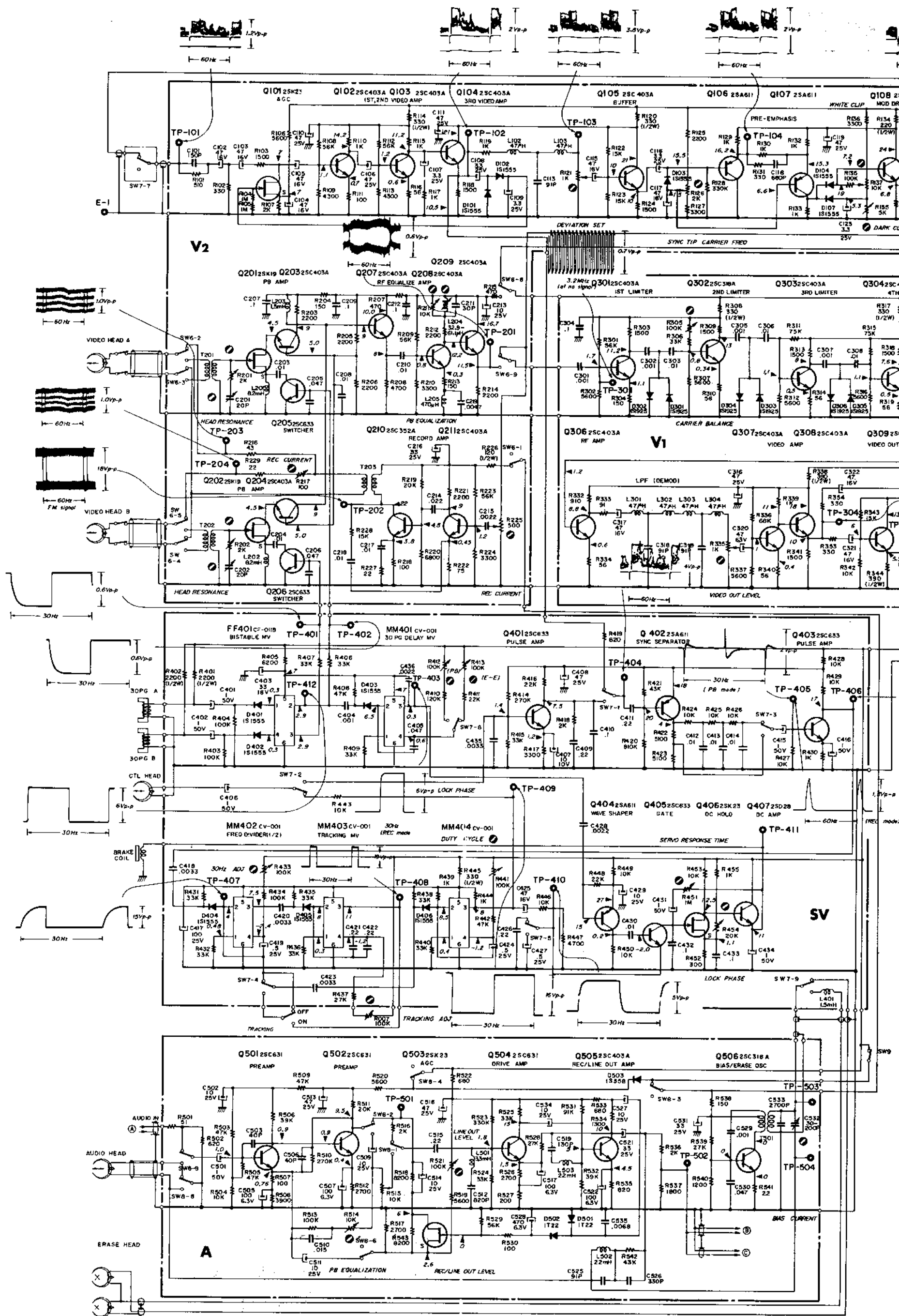

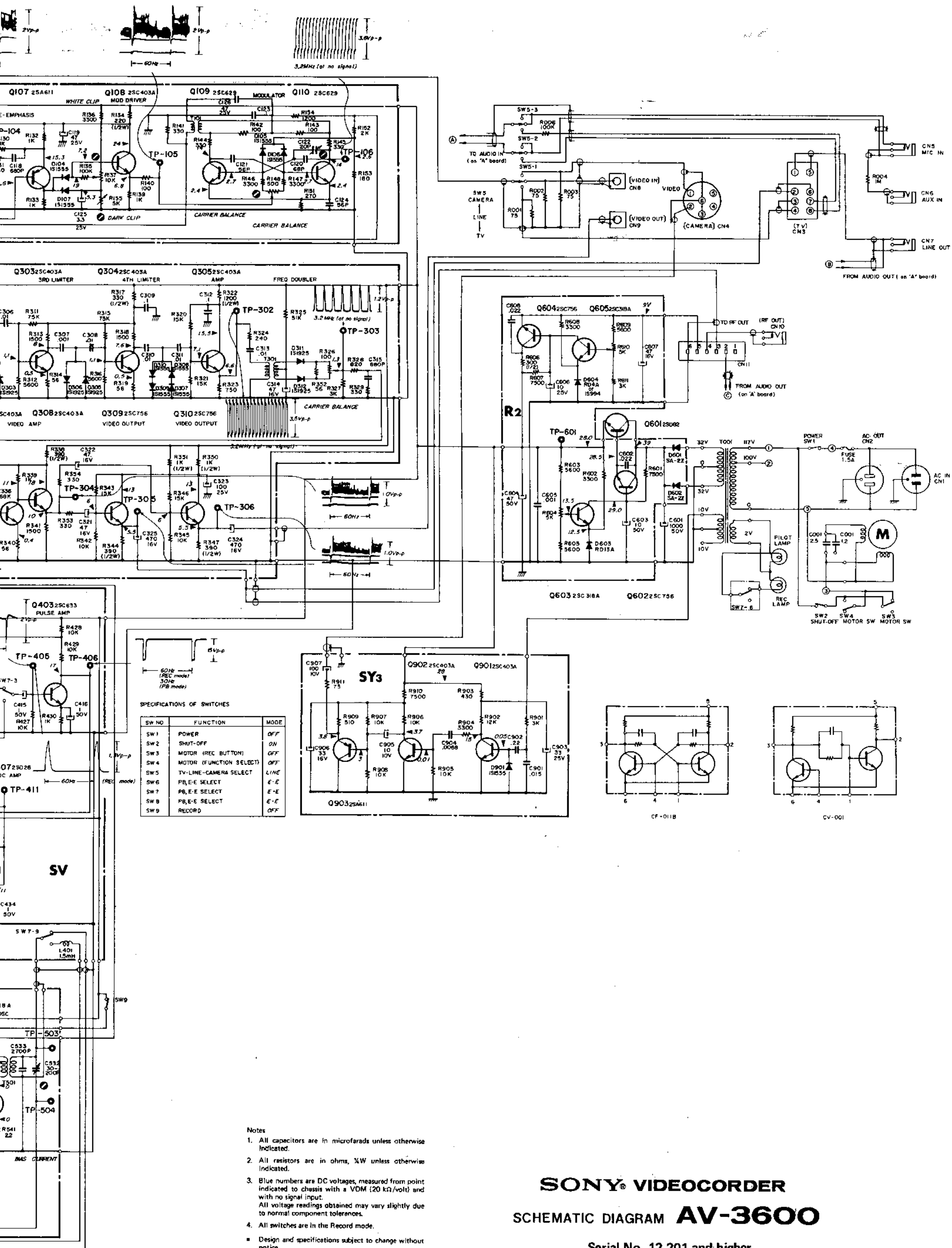

SPECIFICATIONS OF SWITCHES

SW NO	FUNCTION	MODE
SW 1	POWER	OFF
SW 2	SHUT-OFF	ON
SW 3	MOTOR (REC BUTTON)	OFF
SW 4	MOTOR (FUNCTION SELECT)	OFF
SW 5	TV-LINE-CAMERA SELECT	LINE
SW 6	PB,E-E SELECT	E-E
SW 7	PB,E-E SELECT	E-E
SW 8	PB,E-E SELECT	E-E
SW 9	RECORD	OFF

- Notes
1. All capacitors are in microfarads unless otherwise indicated.
 2. All resistors are in ohms, %W unless otherwise indicated.
 3. Blue numbers are DC voltages, measured from point indicated to chassis with a VOM (20 k Ω /volt) and with no signal input. All voltage readings obtained may vary slightly due to normal component tolerances.
 4. All switches are in the Record mode.
- Design and specifications subject to change without notice.

SONY® VIDEORECORDER
SCHEMATIC DIAGRAM AV-3600
 Serial No. 12,201 and higher

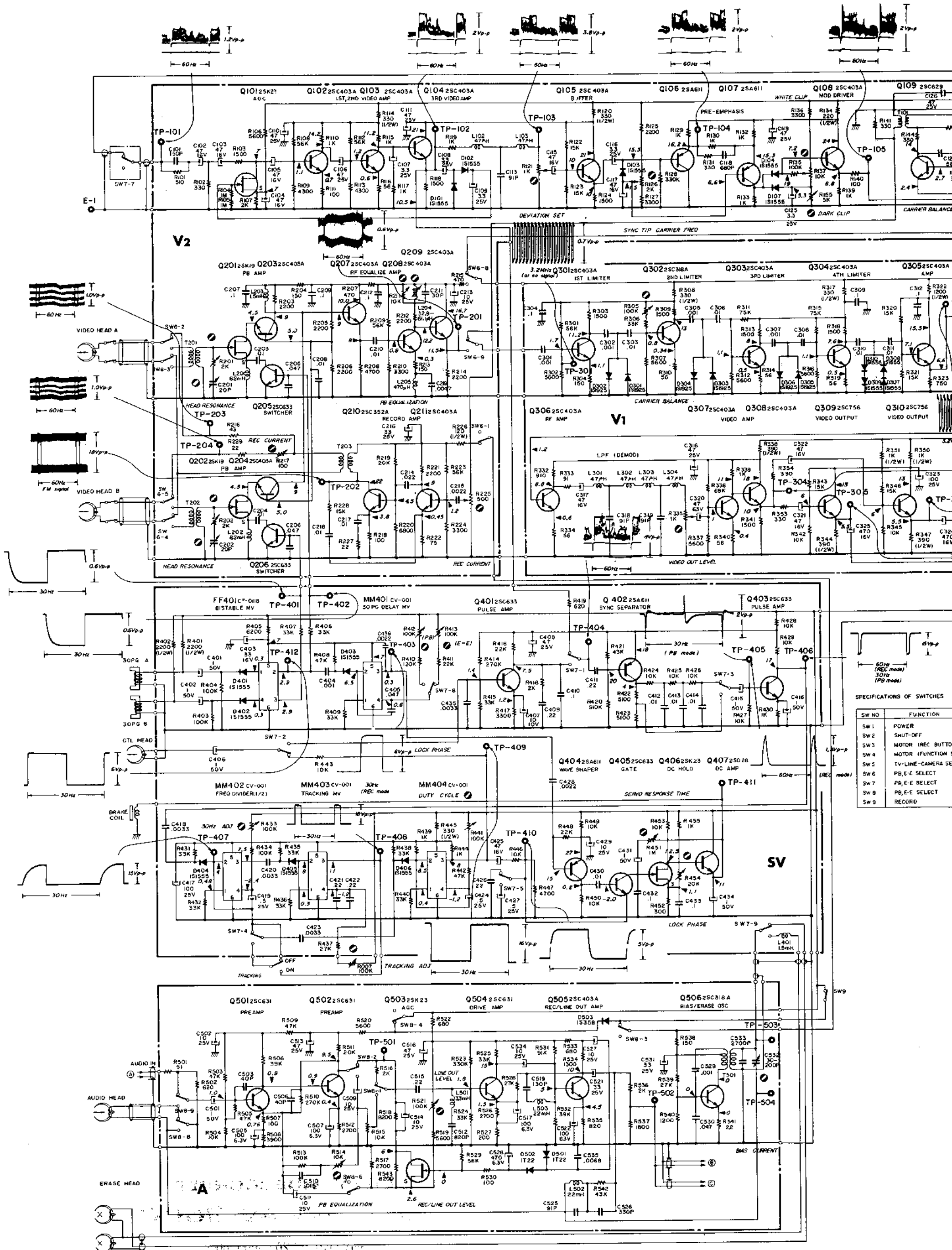

SPECIFICATIONS OF SWITCHES

SW NO	FUNCTION
SW 1	POWER
SW 2	SHUT-OFF
SW 3	MOTOR I/REC BUTTON
SW 4	MOTOR I/FUNCTION S
SW 5	TV-LINE-CAMERA SEL
SW 6	PB, E-2 SELECT
SW 7	PB, E-1 SELECT
SW 8	PB, E-E SELECT
SW 9	RECORD

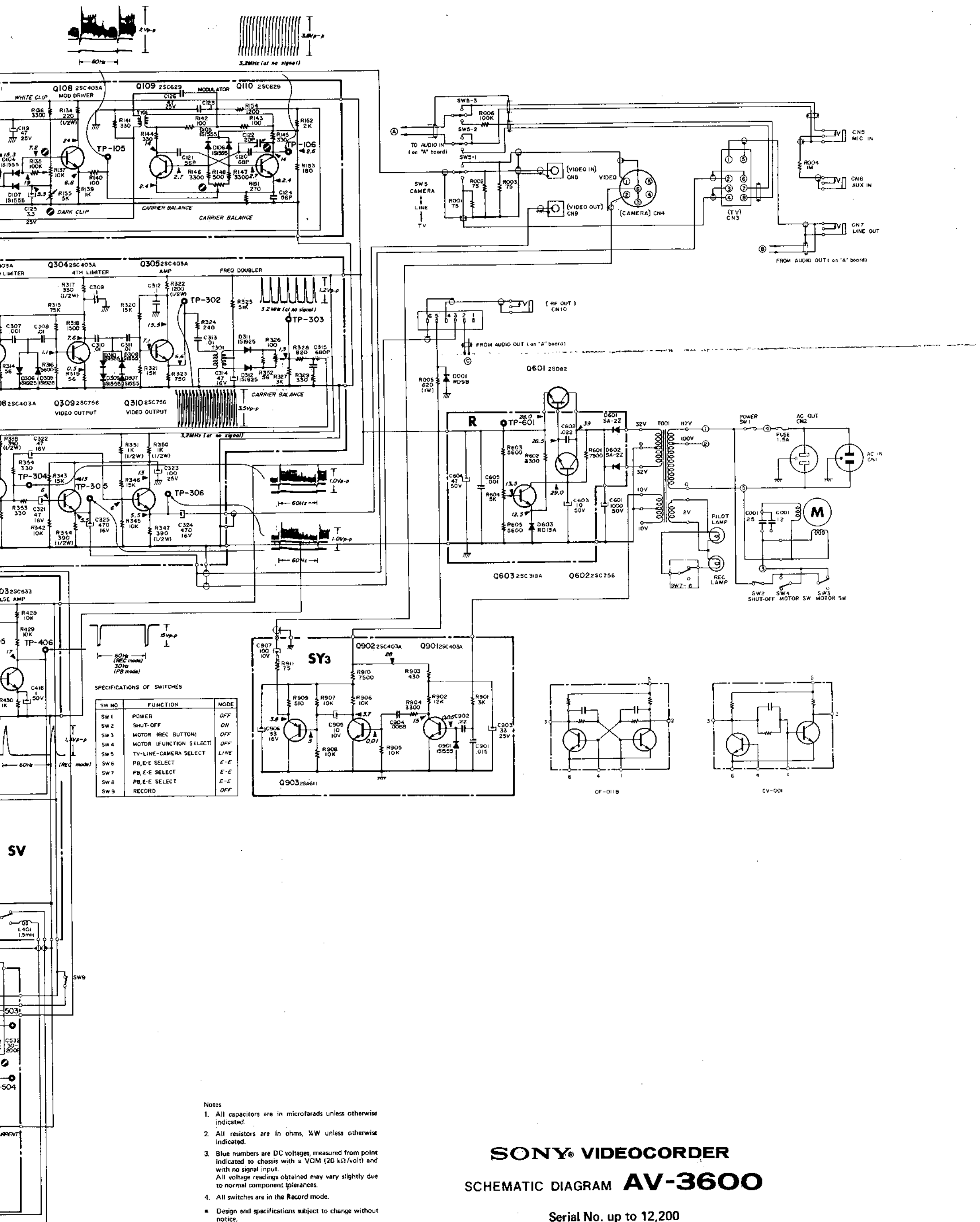

SONY® VIDEORECORDER
SCHEMATIC DIAGRAM AV-3600
 Serial No. up to 12,200

SECTION 10

ELECTRICAL PARTS LIST

10-1. V2 VIDEO AMP, MODULATOR & REC/PB AMP

<u>Ref. No.</u>	<u>Part No.</u>	<u>Description</u>
	98-4042-20	V2 Printed Circuit Board, with components

CAPACITORS

All capacitors in microfarads, $\pm 20\%$, unless otherwise indicated. (pF = $\mu\mu\text{F}$)

Tolerance of all electrolytic (elect) capacitors as follows:

less than 4.7 μF = -10%, +150%

4.7 μF and higher = -10%, +100%

C101	1-107-135-11	150 pF $\pm 10\%$ 50V, silvered mica
C102	1-121-409-11	47 16V, elect
C103	1-121-409-11	47 16V, elect
C104	1-121-409-11	47 16V, elect
C105	1-121-409-11	47 16V, elect
C106	1-121-410-11	47 25V, elect
C107	1-121-392-11	3.3 25V, elect
C108	1-121-392-11	3.3 25V, elect
C109	1-121-392-11	3.3 25V, elect
C110	1-121-410-11	47 25V, elect
C111	1-121-410-11	47 25V, elect
C113	1-107-130-11	91 pF $\pm 10\%$ 50V, silvered mica
C115	1-121-409-11	47 16V, elect
C116	1-121-392-11	3.3 25V, elect
C117	1-121-409-11	47 16V, elect
C118	1-129-664-11	680 pF $\pm 10\%$ 50V, plastic film
C119	1-121-410-11	47 25V, elect
C120	1-107-127-11	68 pF $\pm 10\%$ 50V, silvered mica
C121	1-107-125-11	56 pF $\pm 10\%$ 50V, silvered mica
C122	1-141-070-11	20 pF trimmer
C123	1-105-845-12	0.1 50V, mylar
C124	1-107-125-11	56 pF $\pm 10\%$ 50V, silvered mica
C125	1-121-392-11	3.3 25V, elect
C126	1-121-410-11	47 25V, elect
C201	1-141-070-11	20 pF trimmer
C202	1-141-070-11	20 pF trimmer
C203	1-105-833-12	0.01 50V, mylar
C204	1-105-833-12	0.01 50V, mylar
C205	1-105-841-12	0.047 50V, mylar
C206	1-105-841-12	0.047 50V, mylar
C207	1-105-845-12	0.1 50V, mylar
C208	1-105-833-12	0.01 50V, mylar
C209	1-105-845-12	0.1 50V, mylar
C210	1-105-845-12	0.1 50V, mylar

<u>Ref. No.</u>	<u>Part No.</u>	<u>Description</u>
C211	1-107-118-11	30 pF $\pm 10\%$ 50V, silvered mica
C212	1-105-845-12	0.1 50V, mylar
C213	1-121-398-11	10 25V, elect
C214	1-105-837-12	0.022 50V, mylar
C215	1-105-825-12	0.0022 50V, mylar
C216	1-121-404-11	33 25V, elect
C217	1-105-833-12	0.01 50V, mylar
C218	1-105-833-12	0.01 50V, mylar
C219	1-105-829-11	0.0047 50V, mylar

DIODES

D101	1S1555
D102	1S1555
D103	1S1555
D104	1S1555
D105	1S1555
D106	1S1555
D107	1S1555

INDUCTORS

L102	1-407-165-11	47 μH
L103	1-407-165-11	47 μH
L201	1-407-205-11	8.2 mH
L202	1-407-205-11	8.2 mH
L203	1-407-213-11	1.5 mH
L204	1-407-255-11	32.9 - 61.1 μF , variable
L205	1-407-177-11	470 μH

TRANSISTORS

Q101	2SK23
Q102	2SC403A
Q103	2SC403A
Q104	2SC403A
Q105	2SC403A
Q106	2SA611
Q107	2SA611
Q108	2SC403A
Q109	2SC629
Q110	2SC629
Q201	2SK19
Q202	2SK19
Q203	2SC403A
Q204	2SC403A
Q205	2SC633
Q206	2SC633

<u>Ref. No.</u>	<u>Part No.</u>	<u>Description</u>	<u>Ref. No.</u>	<u>Part No.</u>	<u>Description</u>
Q207		2SC403A	R141	1-242-661-11	330
Q208		2SC403A	R142	1-242-649-11	100
Q209		2SC403A	R143	1-242-649-11	100
Q210		2SC352A	R144	1-242-661-11	330
Q211		2SC403A	R145	1-242-661-11	330
<u>RESISTORS</u>			R146	1-242-685-11	3300
All resistors in ohms, $\pm 5\%$, $\frac{1}{4}W$, fixed, carbon, unless otherwise indicated. (k = 1000, M = 1000 k)			R147	1-242-685-11	3300
R101	1-242-666-11	510	R148	1-221-494-11	500, adjustable (linear)
R102	1-242-661-11	330	R151	1-242-659-11	270
R103	1-242-677-11	1500	R152	1-242-680-11	2 k
R104	1-242-745-11	1 M	R153	1-242-655-11	180
R105	1-242-745-11	1 M	R154	1-242-675-11	1200
R106	1-242-691-11	5600	R155	1-221-497-11	5 k, adjustable (linear)
R107	1-242-680-11	2 k	R201	1-221-496-11	2 k, adjustable (linear)
R108	1-242-715-11	56 k	R202	1-221-496-11	2 k, adjustable (linear)
R109	1-242-688-11	4300	R203	1-242-681-11	2200
R110	1-242-673-11	1 k	R204	1-242-653-11	150
R111	1-242-649-11	100	R205	1-242-681-11	2200
R112	1-242-715-11	56 k	R206	1-242-681-11	2200
R113	1-242-688-11	4300	R207	1-242-665-11	470
R114	1-250-861-11	330, $\frac{1}{2}W$	R208	1-242-689-11	4700
R115	1-242-673-11	1 k	R209	1-242-715-11	56 k
R116	1-242-643-11	56	R210	1-242-685-11	3300
R117	1-242-673-11	1 k	R211	1-221-498-11	10 k, adjustable (linear)
R118	1-242-677-11	1500	R212	1-242-681-11	2200
R119	1-242-673-11	1 k	R213	1-242-653-11	150
R120	1-250-861-11	330, $\frac{1}{2}W$	R214	1-242-681-11	2200
R121	1-221-495-11	1 k, adjustable (linear)	R215	1-242-665-11	470
R122	1-242-701-11	15 k	R216	1-242-640-11	43
R123	1-242-701-11	15 k	R217	1-221-492-11	100, adjustable (linear)
R124	1-242-677-11	1500	R218	1-242-649-11	100
R125	1-242-681-11	2200	R219	1-242-704-11	20 k
R126	1-221-496-11	2 k, adjustable (linear)	R220	1-242-693-11	6800
R127	1-242-685-11	3300	R221	1-242-681-11	2200
R128	1-242-733-11	330 k	R222	1-242-646-11	75
R129	1-242-673-11	1 k	R223	1-242-715-11	56 k
R130	1-242-673-11	1 k	R224	1-242-685-11	3300
R131	1-242-661-11	330	R225	1-221-494-11	500, adjustable (linear)
R132	1-242-673-11	1 k	R226	1-250-851-11	120, $\frac{1}{2}W$
R133	1-242-673-11	1 k	R227	1-242-633-11	22
R134	1-242-857-11	220, $\frac{1}{2}W$	R228	1-242-701-11	15 k
R135	1-242-721-11	100 k	R229	1-242-633-11	22
R136	1-242-685-11	3300	<u>SWITCH</u>		
R137	1-221-498-11	10 k, adjustable (linear)	SW6	1-514-454-12	Slide Switch
R139	1-242-673-11	1 k	<u>TRANSFORMERS</u>		
R140	1-242-649-11	100	T101	1-425-383-11	Transformer, modulator
			T201	1-423-151-11	Transformer, TPB

<u>Ref. No.</u>	<u>Part No.</u>	<u>Description</u>
T202	1-423-151-11	Transformer, TPB
T203	1-425-543-11	Transformer, TR

<u>Ref. No.</u>	<u>Part No.</u>	<u>Description</u>
-----------------	-----------------	--------------------

DIODES

D301	1S1925
D302	1S1925
D303	1S1925
D304	1S1925
D305	1S1925
D306	1S1925
D307	1S1555
D308	1S1555
D309	1S1555
D310	1S1555
D311	1S1925
D312	1S1925

10-2. V1 LIMITER & DEMODULATOR

<u>Ref. No.</u>	<u>Part No.</u>	<u>Description</u>
98-4042-10	V1	Printed Circuit Board, with components

INDUCTORS

L301	1-407-165-11	47 μ H
L302	1-407-165-11	47 μ H
L303	1-407-165-11	47 μ H
L304	1-407-165-11	47 μ H

CAPACITORS

All capacitors in microfarads, $\pm 20\%$, unless otherwise indicated. (pF = μ F)

Tolerance of all electrolytic (elect) capacitors as follows:

less than 4.7 μ F = -10% , +150%

4.7 μ F and higher = -10% , +100%

C301	1-105-821-12	0.001	50V, mylar
C302	1-105-821-12	0.001	50V, mylar
C303	1-105-833-12	0.01	50V, mylar
C304	1-101-044-11	0.1	50V, ceramic
C305	1-105-821-12	0.001	50V, mylar
C306	1-105-833-12	0.01	50V, mylar
C307	1-105-821-12	0.001	50V, mylar
C308	1-105-833-12	0.01	50V, mylar
C309	1-101-044-11	0.1	50V, ceramic
C310	1-105-833-12	0.01	50V, mylar
C311	1-105-833-12	0.01	50V, mylar
C312	1-101-044-11	0.1	50V, ceramic
C313	1-105-833-12	0.01	50V, mylar
C314	1-121-338-11	47	16V, elect
C315	1-129-664-11	680 pF $\pm 10\%$	50V, plastic film
C316	1-121-410-11	47	25V, elect
C317	1-121-338-11	47	16V, elect
C318	1-107-084-11	91 pF $\pm 5\%$	50V, silvered mica
C319	1-107-084-11	91 pF $\pm 5\%$	50V, silvered mica
C320	1-121-487-11	47	6.3V, elect
C321	1-121-338-11	47	16V, elect
C322	1-121-338-11	47	16V, elect
C323	1-121-377-11	100	25V, elect
C324	1-121-426-11	470	16V, elect
C325	1-121-426-11	470	16V, elect

TRANSISTORS

Q301	2SC403A
Q302	2SC318A
Q303	2SC403A
Q304	2SC403A
Q305	2SC403A
Q306	2SC403A
Q307	2SC403A
Q308	2SC403A
Q309	2SC756
Q310	2SC756

RESISTORS

All resistors in ohms, $\pm 5\%$, $\frac{1}{4}$ W, fixed, carbon, unless otherwise indicated. (k = 1000, M = 1000 k)

R301	1-242-715-11	56 k
R302	1-242-691-11	5600
R303	1-242-677-11	1500
R304	1-242-653-11	150
R305	1-221-323-11	100 k, adjustable (linear)
R306	1-242-709-11	33 k
R307	1-242-691-11	5600
R308	1-250-861-11	330, $\frac{1}{2}$ W
R309	1-242-677-11	1500
R310	1-242-643-11	56
R311	1-242-718-11	75 k

<u>Ref. No.</u>	<u>Part No.</u>	<u>Description</u>
R312	1-242-691-11	5600
R313	1-242-677-11	1500
R314	1-242-643-11	56
R315	1-242-718-11	75 k
R316	1-242-691-11	5600
R317	1-250-861-11	330, ½W
R318	1-242-677-11	1500
R319	1-242-643-11	56
R320	1-242-701-11	15 k
R321	1-242-701-11	15 k
R322	1-250-875-11	1200, ½W
R323	1-242-670-11	750
R324	1-242-658-11	240
R325	1-242-714-11	51 k
R326	1-221-492-11	100, adjustable (linear)
R327	1-242-684-11	3 k
R328	1-242-671-11	820
R329	1-242-661-11	330
R332	1-242-672-11	910
R333	1-242-648-11	91
R334	1-242-643-11	56
R335	1-221-495-11	1 k, adjustable (linear)
R336	1-242-717-11	68 k
R337	1-242-691-11	5600
R338	1-250-863-11	390, ½W
R339	1-242-673-11	1 k
R340	1-242-643-11	56
R341	1-242-677-11	1500
R342	1-242-697-11	10 k
R343	1-242-701-11	15 k
R344	1-250-863-11	390, ½W
R345	1-242-697-11	10 k
R346	1-242-701-11	15 k
R347	1-250-863-11	390, ½W
R350	1-250-873-11	1 k, ½W
R351	1-250-873-11	1 k, ½W
R352	1-242-643-11	56
R353	1-242-661-11	330
R354	1-242-661-11	330

TRANSFORMER

T301 1-425-544-11 Transformer, TD

10-3. SV SERVO

<u>Ref. No.</u>	<u>Part No.</u>	<u>Description</u>
	98-4042-30	SV Printed Circuit Board, with components

CAPACITORS

All capacitors in microfarads, ± 20%, unless otherwise indicated. (pF = μμF)

Tolerance of all electrolytic (elect) capacitors as follows:

less than 4.7 μF = -10%, + 150%

4.7 μF and higher = -10%, + 100%

C401	1-121-391-11	1	50V, elect
C402	1-121-391-11	1	50V, elect
C403	1-121-403-11	33	16V, elect
C404	1-105-821-12	0.001	50V, mylar
C405	1-105-841-12	0.047	50V, mylar
C406	1-121-391-11	1	50V, elect
C407	1-121-469-11	10	10V, elect
C408	1-121-410-11	47	25V, elect
C409	1-105-849-12	0.22	50V, mylar
C410	1-105-845-12	0.1	50V, mylar
C411	1-105-849-12	0.22	50V, mylar
C412	1-105-833-12	0.01	50V, mylar
C413	1-105-833-12	0.01	50V, mylar
C414	1-105-833-12	0.01	50V, mylar
C415	1-121-391-11	1	50V, elect
C416	1-121-391-11	1	50V, elect
C417	1-121-416-11	100	25V, elect
C418	1-105-827-12	0.0033	50V, mylar
C419	1-127-093-11	0.5	25V, alum-elect
C420	1-105-827-12	0.0033	50V, mylar
C421	1-105-849-12	0.22	50V, mylar
C422	1-105-849-12	0.22	50V, mylar
C423	1-105-827-12	0.0033	50V, mylar
C424	1-127-093-11	0.5	25V, alum-elect
C425	1-121-409-11	47	16V, elect
C426	1-105-849-12	0.22	50V, mylar
C427	1-127-093-11	0.5	25V, alum-elect
C428	1-105-825-12	0.0022	50V, mylar
C429	1-121-398-11	10	25V, elect
C430	1-105-833-12	0.01	50V, mylar
C431	1-121-391-11	1	50V, elect
C432	1-105-845-12	0.1	50V, mylar
C433	1-105-845-12	0.1	50V, mylar
C434	1-121-391-11	1	50V, elect
C435	1-105-827-11	0.0033	50V, mylar
C436	1-105-825-12	0.0022	50V, mylar

<u>Ref. No.</u>	<u>Part No.</u>	<u>Description</u>	<u>Ref. No.</u>	<u>Part No.</u>	<u>Description</u>
<u>DIODES</u>			R416	1-242-705-11	22 k
D401	1S1555		R417	1-242-685-11	3300
D402	1S1555		R418	1-242-680-11	2 k
D403	1S1555		R419	1-242-668-11	620
D404	1S1555		R420	1-242-744-11	910 k
D405	1S1555		R421	1-242-712-11	43 k
D406	1S1555		R422	1-242-690-11	5100
<u>MICRO MODULES</u>			R423	1-242-690-11	5100
FF401	CF-011B		R424	1-242-697-11	10 k
MM401	CV-001		R425	1-242-697-11	10 k
MM402	CV-001		R426	1-242-697-11	10 k
MM403	CV-001		R427	1-242-697-11	10 k
MM404	CV-001		R428	1-242-697-11	10 k
<u>INDUCTOR</u>			R429	1-242-697-11	10 k
L401	1-407-090-12	1.5 mH, dummy coil	R430	1-242-673-11	1 k
<u>TRANSISTORS</u>			R431	1-242-709-11	33 k
Q401	2SC633		R432	1-242-709-11	33 k
Q402	2SA611		R433	1-221-323-01	100 k, adjustable (linear)
Q403	2SC633		R434	1-242-721-11	100 k
Q404	2SA611		R435	1-242-709-11	33 k
Q405	2SC633		R436	1-242-709-11	33 k
Q406	2SK23		R437	1-242-707-11	27 k
Q407	2SD28		R438	1-242-709-11	33 k
<u>RESISTORS</u>			R439	1-242-673-11	1 k
All resistors in ohms, $\pm 5\%$, $\frac{1}{4}W$, fixed, carbon, unless otherwise indicated. (k = 1000, M = 1000 k)			R440	1-242-709-11	33 k
R401	1-250-881-11	2200, $\frac{1}{2}W$	R441	1-221-323-01	100 k, adjustable (linear)
R402	1-250-881-11	2200, $\frac{1}{2}W$	R442	1-242-713-11	47 k
R403	1-242-721-11	100 k	R443	1-242-697-11	10 k
R404	1-242-721-11	100 k	R444	1-242-673-11	1 k
R405	1-242-692-11	6200	R445	1-250-861-11	330, $\frac{1}{2}W$
R406	1-242-709-11	33 k	R446	1-242-697-11	10 k
R407	1-242-709-11	33 k	R447	1-242-689-11	4700
R408	1-242-713-11	47 k	R448	1-242-705-11	22 k
R409	1-242-709-11	33 k	R449	1-242-697-11	10 k
R410	1-242-723-11	120 k	R450	1-242-697-11	10 k
R411	1-242-705-11	22 k	R451	1-221-314-01	1 M, adjustable (linear)
R412	1-221-323-01	100 k, adjustable (linear)	R452	1-242-660-11	300
R413	1-221-323-01	100 k, adjustable (linear)	R453	1-242-697-11	10 k
R414	1-242-731-11	270 k	R454	1-221-499-11	20 k, adjustable (linear)
R415	1-242-709-11	33 k	R455	1-242-673-11	1 k
<u>SWITCH</u>					
			SW7	1-514-454-12	Slide Switch

10-4. A AUDIO

<u>Ref. No.</u>	<u>Part No.</u>	<u>Description</u>
	98-4042-40	A Printed Circuit Board, with components

CAPACITORS

All capacitors in microfarads, $\pm 20\%$, unless otherwise indicated. (pF = μF)

Tolerance of all electrolytic (elect) capacitors as follows:

less than 4.7 μF = -10% , + 150%

4.7 μF and higher = -10% , + 100%

C501	1-121-442-11	1	50V, elect
C502	1-121-472-11	10	25V, elect
C503	1-101-305-11	40 pF	50V, ceramic
C505	1-121-491-11	100	6.3V, elect
C506	1-101-305-11	40 pF	50V, ceramic
C507	1-121-491-11	100	6.3V, elect
C509	1-121-472-11	10	25V, elect
C510	1-105-675-12	0.015	$\pm 10\%$ 50V, mylar
C511	1-121-472-11	10	25V, elect
C512	1-129-665-11	820 pF	$\pm 10\%$ 50V, film
C513	1-121-410-11	47	25V, elect
C514	1-121-472-11	10	25V, elect
C515	1-105-689-12	0.22	$\pm 10\%$ 50V, mylar
C516	1-121-410-11	47	25V, elect
C517	1-121-491-11	100	6.3V, elect
C519	1-107-088-11	130 pF	$\pm 5\%$ 50V, silvered mica
C521	1-121-373-11	33	25V, elect
C522	1-121-491-11	100	6.3V, elect
C525	1-107-130-11	91 pF	$\pm 10\%$ 50V, silvered mica
C526	1-107-097-11	330 pF	$\pm 5\%$ 50V, silvered mica
C527	1-121-472-11	10	25V, elect
C528	1-121-342-11	470	6.3V, elect
C529	1-105-661-12	0.001	$\pm 10\%$ 50V, mylar
C530	1-105-681-12	0.047	$\pm 10\%$ 50V, mylar
C531	1-121-373-11	33	25V, elect
C532	1-141-034-21	30-200 pF	trimmer
C533	1-129-707-11	2700 pF	$\pm 10\%$ 600V, film
C534	1-121-472-11	10	25V, elect
C535	1-105-671-12	0.0068	$\pm 10\%$ 50V, mylar

DIODES

D501	1T22M
D502	1T22M
D503	1S358

Ref. No. Part No. Description

INDUCTORS

L501	1-407-200-11	3.3 mH
L502	1-407-240-11	22 mH, variable
L503	1-407-210-11	22 mH

TRANSISTORS

Q501	2SC631
Q502	2SC631
Q503	2SK23
Q504	2SC631
Q505	2SC403A
Q506	2SC318A

RESISTORS

All resistors in ohms, $\pm 5\%$, $\frac{1}{4}$ W, fixed, carbon, unless otherwise indicated. (k = 1000, M = 1000 k)

R501	1-242-642-11	51
R502	1-242-668-11	620
R503	1-242-713-11	47 k
R504	1-242-697-11	10 k
R505	1-242-713-11	47 k
R506	1-242-711-11	39 k
R507	1-242-649-11	100
R508	1-242-687-11	3900
R509	1-242-713-11	47 k
R510	1-242-731-11	270 k
R511	1-242-704-11	20 k
R512	1-242-683-11	2700
R513	1-242-721-11	100 k
R514	1-221-359-12	10 k, adjustable (linear)
R515	1-221-359-12	10 k, adjustable (linear)
R516	1-242-680-11	2 k
R517	1-242-682-11	2700
R518	1-242-695-11	8200
R519	1-242-691-11	5600
R520	1-242-691-11	5600
R521	1-221-323-01	100 k, adjustable (linear)
R522	1-242-669-11	680
R523	1-242-733-11	330 k
R524	1-242-709-11	33 k
R525	1-242-709-11	33 k
R526	1-242-683-11	2700
R527	1-242-656-11	200
R528	1-242-707-11	27 k
R529	1-242-715-11	56 k
R530	1-242-649-11	100
R531	1-242-720-11	91 k

<u>Ref. No.</u>	<u>Part No.</u>	<u>Description</u>
R532	1-242-711-11	39 k
R533	1-242-669-11	680
R534	1-242-676-11	1300
R535	1-242-671-11	820
R536	1-242-680-11	2 k
R537	1-242-679-11	1800
R538	1-242-653-11	150
R539	1-242-707-11	27 k
R540	1-242-675-11	1200
R541	1-242-609-11	2.2
R542	1-242-712-11	43 k
R543	1-242-695-11	8200

SWITCH

SW8 1-514-454-12 Slide Switch

TRANSFORMER

T501 1-433-137-11 Transformer, bias oscillator

10-5. R, R2 VOLTAGE REGULATOR

<u>Ref. No.</u>	<u>Part No.</u>	<u>Description</u>
	98-4042-50	R Printed Circuit Board, with components
		R2 Printed Circuit Board, with components

CAPACITORS

All capacitors in microfarads, $\pm 20\%$, unless otherwise indicated. ($\mu\text{F} = \mu\mu\text{F}$)

Tolerance of all electrolytic (elect) capacitors as follows:

less than $4.7 \mu\text{F} = -10\%, +150\%$

$4.7 \mu\text{F}$ and higher = $-10\%, +100\%$

C602	1-105-837-12	0.022	50V, mylar
C603	1-121-474-11	10	50V, elect
C604	1-121-411-11	47	50V, elect
C605	1-105-821-12	0.001	50V, mylar
† C606	1-121-398-11	10	25V, elect
† C607	1-121-409-11	47	16V, elect
† C608	1-105-837-12	0.022	50V, mylar

<u>Ref. No.</u>	<u>Part No.</u>	<u>Description</u>
-----------------	-----------------	--------------------

DIODES

D601		SA2Z
D602		SA2Z
D603		RD13A
† D604		RD4A

TRANSISTORS

Q602		2SC756
Q603		2SC318A
† Q604		2SC756
† Q605		2SC318A

RESISTORS

All resistors in ohms, $\pm 5\%$, $\frac{1}{4}\text{W}$, fixed, carbon, unless otherwise indicated. (k = 1000, M = 1000 k)

R601	1-242-694-11	7500
R602	1-242-685-11	3300
R603	1-242-691-11	5600
R604	1-221-650-11	5 k, adjustable (linear)
R605	1-242-691-11	5600
† R606	1-250-860-11	300, $\frac{1}{2}\text{W}$
† R607	1-242-694-11	7500
† R608	1-242-685-11	3300
† R609	1-242-691-11	5600
† R610	1-221-650-11	5 k, adjustable (linear)
† R611	1-242-684-11	3 k

Note: Items marked with (†) are mounted on the R2 Board only.

10-6. SY3 SYNC FORMER

<u>Ref. No.</u>	<u>Part No.</u>	<u>Description</u>
	98-4042-80	SY3 Printed Circuit Board, with components

CAPACITORS

All capacitors in microfarads, $\pm 20\%$, unless otherwise indicated. ($\mu\text{F} = \mu\mu\text{F}$)

Tolerance of all electrolytic (elect) capacitors as follows:

less than $4.7 \mu\text{F} = -10\%, +150\%$

$4.7 \mu\text{F}$ and higher = $-10\%, +100\%$

<u>Ref. No.</u>	<u>Part No.</u>	<u>Description</u>	
C901	1-105-835-12	0.015	50V, mylar
C902	1-105-849-12	0.22	50V, mylar
C903	1-121-404-11	33	25V, elect
C904	1-105-831-12	0.0068	50V, mylar
C905	1-121-469-11	10	10V, elect
C906	1-121-403-11	33	16V, elect
C907	1-121-414-11	100	10V, elect

DIODE

D901 1S1555

TRANSISTORS

Q901 2SC403A
 Q902 2SC403A
 Q903 2SA611

RESISTORS

All resistors in ohms, $\pm 5\%$, $\frac{1}{4}W$, fixed, carbon, unless otherwise indicated. (k = 1000, M = 1000 k)

R901 1-242-684-11 3 k
 R902 1-242-699-11 12 k
 R903 1-242-664-11 430
 R904 1-242-685-11 3300
 R905 1-242-697-11 10 k
 R906 1-242-697-11 10 k
 R907 1-242-697-11 10 k
 R908 1-242-697-11 10 k
 R909 1-242-666-11 510
 R910 1-242-694-11 7500
 R911 1-242-646-11 75

<u>Ref. No.</u>	<u>Part No.</u>	<u>Description</u>
-----------------	-----------------	--------------------

CONNECTORS

CN1 1-508-379-11 Receptacle, AC input
 CN2 1-509-332-11 Receptacle, AC outlet
 CN3 1-509-095-11 8-pin receptacle, TV
 CN4 1-526-063-11 6-pin receptacle, CAMERA
 CN5 1-507-053-04 Mini Jack
 CN6 1-507-053-04 Mini Jack
 CN7 1-507-053-04 Mini Jack
 CN8 1-526-071-41 UHF connector
 CN9 1-526-071-41 UHF connector
 CN10 1-507-053-04 Mini Jack
 CN11 1-507-290-12 6-pin socket, RF adaptor
 1-517-003-00 Socket, lamp

TRANSISTOR

Q601 2SD82

RESISTORS

R001 1-242-646-11 75 $\pm 5\%$ $\frac{1}{4}W$, carbon
 R002 1-242-646-11 75 $\pm 5\%$ $\frac{1}{4}W$, carbon
 R003 1-242-646-11 75 $\pm 5\%$ $\frac{1}{4}W$, carbon
 R004 1-242-745-11 1 M $\pm 5\%$ $\frac{1}{4}W$, carbon
 R006 1-242-721-00 100 k $\pm 5\%$ $\frac{1}{4}W$, carbon
 R007 1-222-327-11 100 k variable

SWITCHES

SW1 1-514-140-23S Pushbutton Switch
 SW2 1-514-039-12 Microswitch
 SW3 1-514-423-11 Microswitch
 SW4 1-514-057-10 Microswitch
 SW5 1-514-335-11 Slide Switch
 SW9 1-514-583-11 Leaf Switch

TRANSFORMER

PT 1-441-600-12 Transformer, power

10-7. FRAME

<u>Ref. No.</u>	<u>Part No.</u>	<u>Description</u>
-----------------	-----------------	--------------------

CAPACITORS

C001 1-113-069-11 2.5 μF + 1.2 μF - 5 + 10% 250V, metalized paper
 C601 1-121-074-21 1000 μF - 10 +100% 50V, elect

























MISCELLANEOUS

1-518-052-21 Pilot Lamp
 1-532-219-11 Fuse
 1-533-048-11 Fuse Post
 1-536-176-11 Terminal Strip, 5-pin
 1-539-493-12 SW Printed Circuit Board
 8-821-221-05 Audio Head
 8-831-634-06 Motor

SECTION 11

EXPLODED VIEWS WITH PART NUMBERS

Hardware Nomenclature

P	- Pan Head Screw		
PS	- Pan Head Screw with Spring Washer		
K	- Flat Countersunk Head Screw ...		
B	- Binding Head Screw		
RK	- Oval Countersunk Head Screw ...		
T	- Truss Head Screw		
R	- Round Head Screw		
F	- Flat Fillister Head Screw		
SC	- Set Screw		
E	- Retaining Ring (E Washer)		
	W - Washer		
	SW - Spring Washer		
	LW - Lock Washer		
	N - Nut		
- Example -			
	Type of Slot		
	P 3x10		
	Length in mm (L)		
	Diameter in mm (D)		
	Type of Head		

All screws conform to ISO standards, unless otherwise noted

Scale:  25.4 millimeters

 1 inch

11-1. CABINET ASSEMBLY EXPLODED VIEW

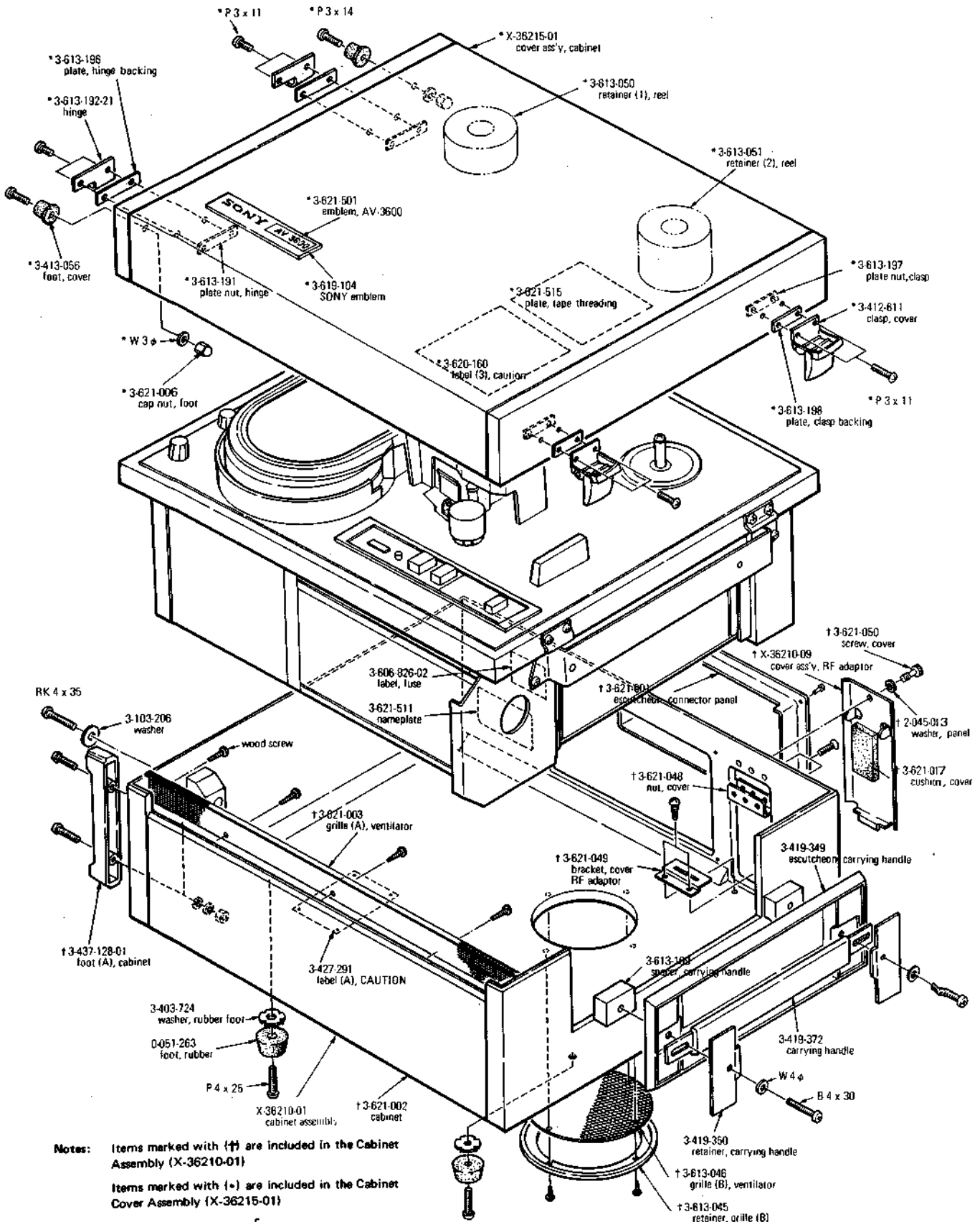

Notes: Items marked with (†) are included in the Cabinet Assembly (X-36210-01)
 Items marked with (*) are included in the Cabinet Cover Assembly (X-36215-01)

11-2. REEL PANEL AND SASH EXPLODED VIEW

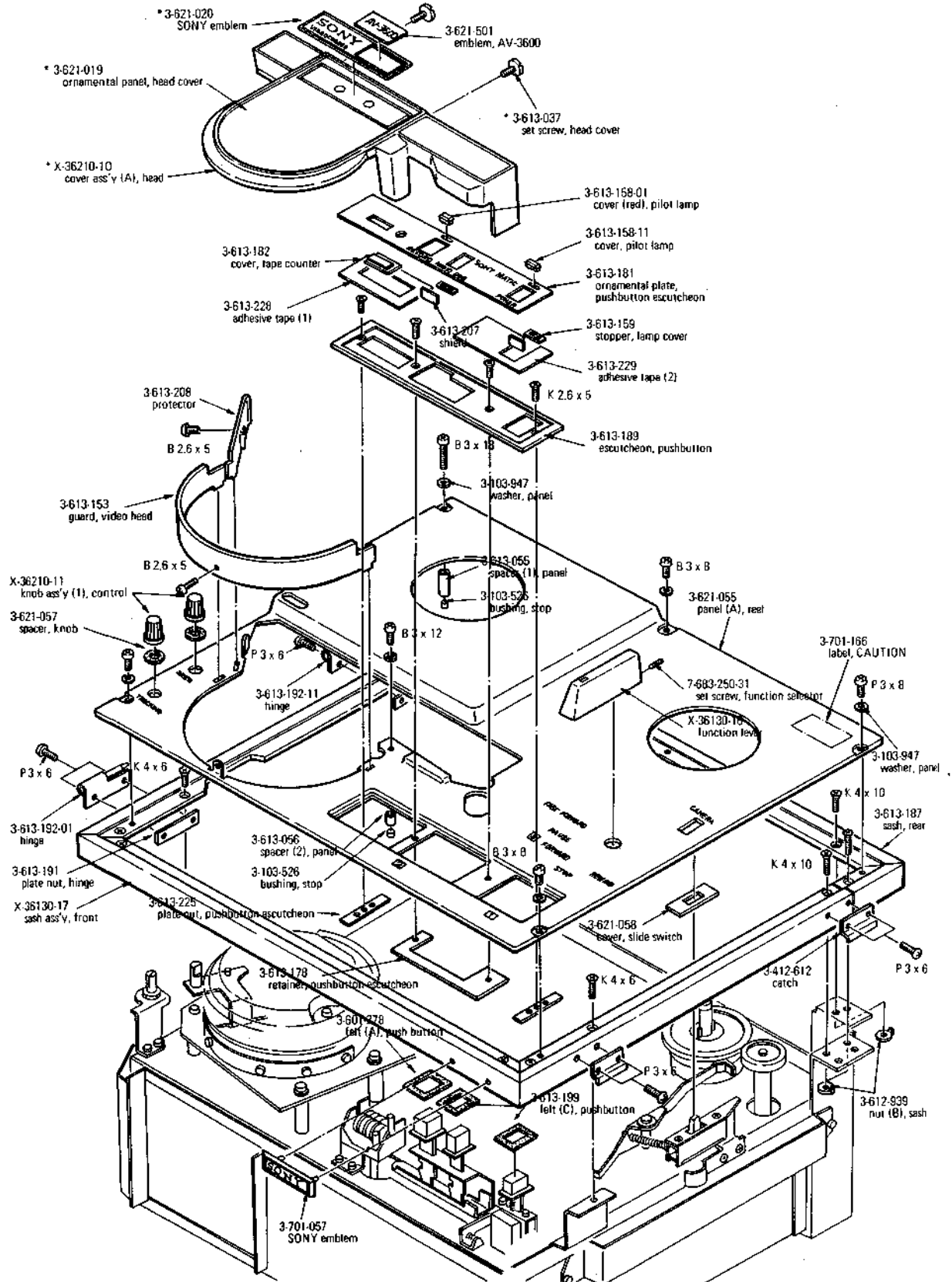

11-3. HEAD DRUM ASSEMBLY EXPLODED VIEW
 (Video Head Drum Assembly 94-5517-02 (60 Hz))

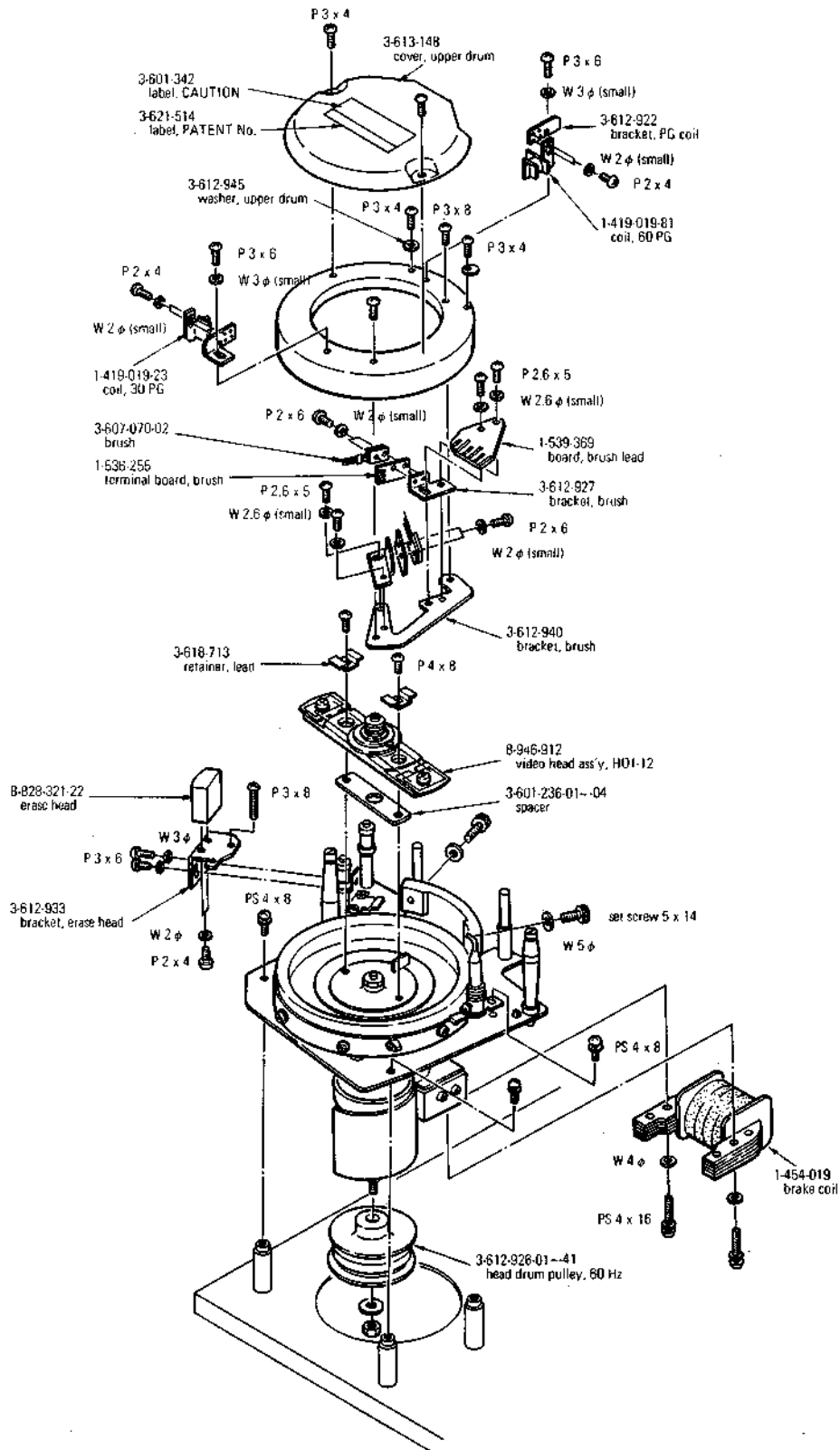

11-4. CAPSTAN DECK ASSEMBLY AND MOTOR EXPLODED VIEW

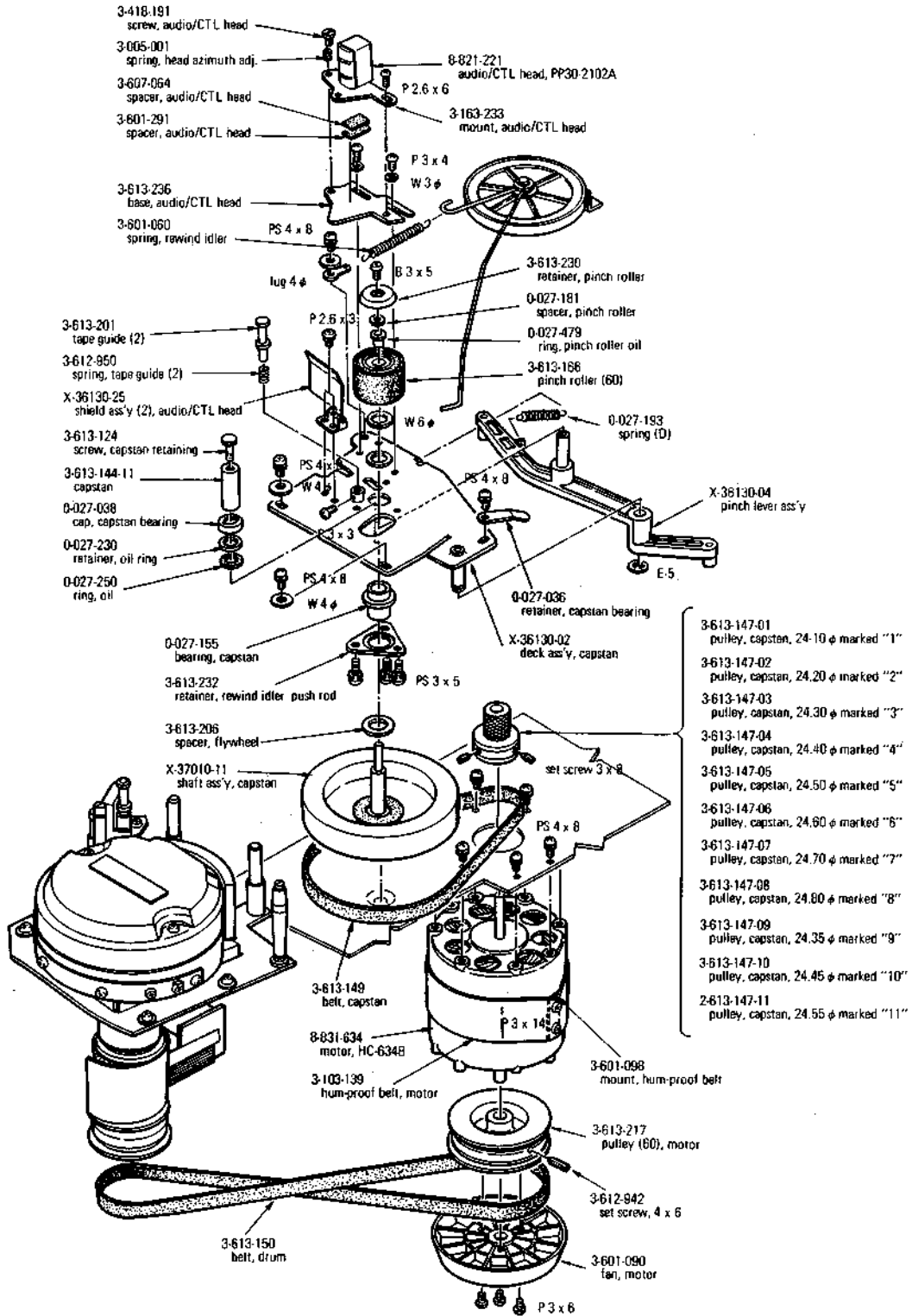

11-5. TAPE TRANSPORT 1 EXPLODED VIEW

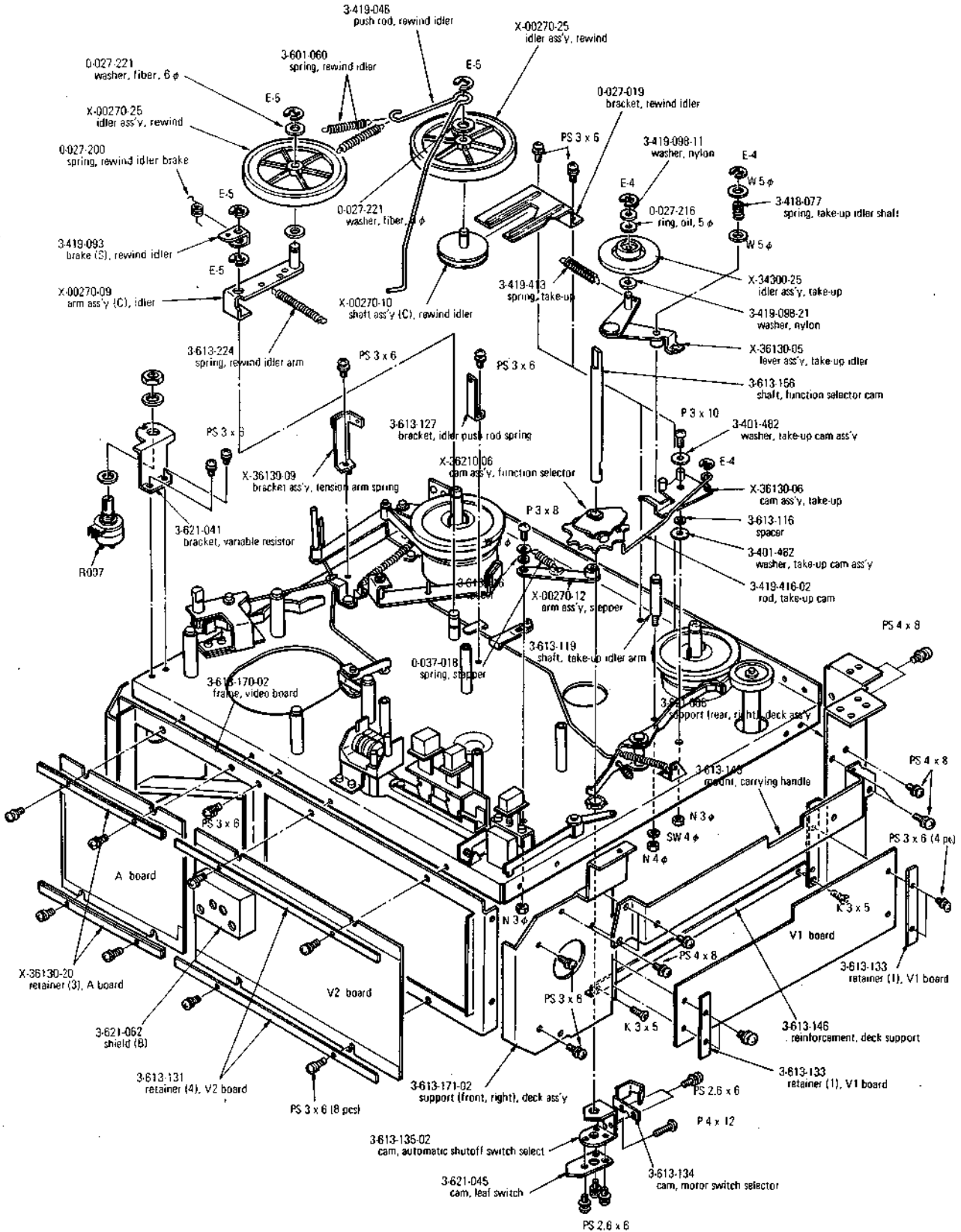

11-7. RECORD SWITCH LINKAGE EXPLODED VIEW

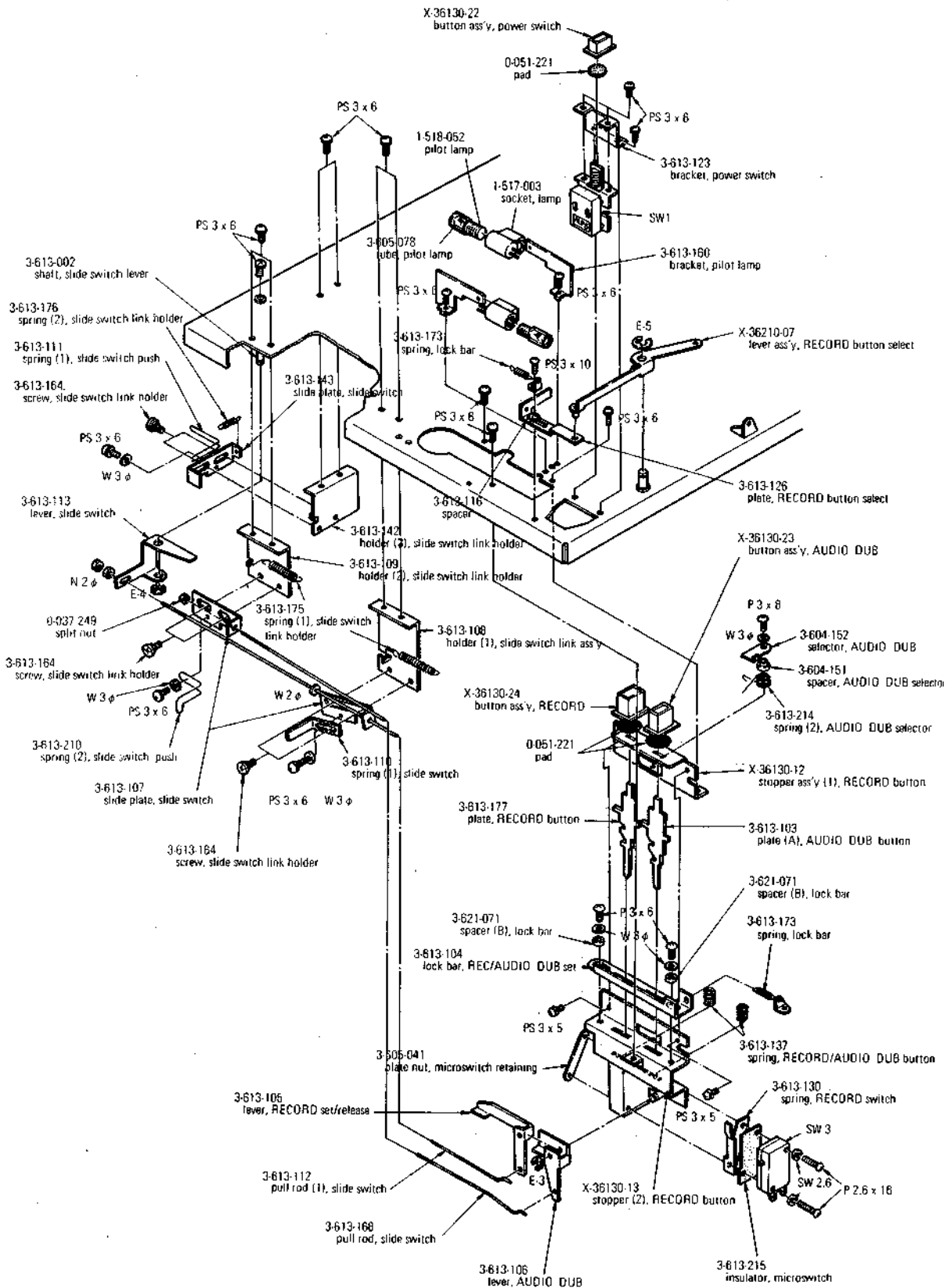

11-10. HARDWARE PARTS LIST

<u>Part No.</u>	<u>Description</u>	<u>Part No.</u>	<u>Description</u>
	<u>SCREWS</u>		
7-621-259-25	(+) P 2.6 x 4	7-624-105-01	E Washer, 2.3
7-621-259-45	(+) P 2.6 x 6	7-624-106-01	E Washer, 3
7-621-260-05	(+) P 2.6 x 16	7-624-108-01	E Washer, 4
7-621-559-25	(+) K 2.6 x 4	7-624-109-01	E Washer, 5
7-621-559-35	(+) K 2.6 x 5		<u>LUG</u>
7-621-773-60	(+) B 2.6 x 5	7-623-510-01	4 mm dia
7-682-144-01	(+) P 3 x 3, tape guide		<u>NAIL</u>
7-682-145-01	(+) P 3 x 4, upper drum washer	7-629-100-19	1 x 6
7-682-145-14	(+) P 3 x 4		<u>NUTS</u>
7-682-147-01	(+) P 3 x 6, PG coil bracket	7-622-105-01	2 mm dia
7-682-148-01	(+) P 3 x 8	7-684-013-01	3 mm dia
7-682-148-14	(+) P 3 x 8 (connector panel)	7-684-014-01	4 mm dia
7-682-149-01	(+) P 3 x 10, brush mt'g board		The following items are used for the Head Drum Ass'y.
7-682-151-01	(+) P 3 x 14		<u>SCREWS</u>
7-682-160-01	(+) P 4 x 6	7-621-255-25	(+) P 2 x 4
7-682-163-01	(+) P 4 x 12, stator	7-621-255-45	(+) P 2 x 6
7-682-166-01	(+) P 4 x 20	7-621-259-12	(+) P 2.6 x 3
7-682-246-01	(+) K 3 x 5	7-621-259-32	(+) P 2.6 x 5
7-682-247-01	(+) K 3 x 6	7-621-309-32	(-) F 2.6 x 5
7-682-248-01	(+) K 3 x 8	7-682-144-01	(+) P 3 x 3
7-682-260-01	(+) K 4 x 6	7-682-145-01	(+) P 3 x 4
7-682-262-01	(+) K 4 x 10	7-682-146-13	(+) P 3 x 5
7-682-369-04	(+) RK 4 x 35 (carrying handle)	7-682-147-01	(+) P 3 x 6
7-682-546-14	(+) B 3 x 5	7-682-148-01	(+) P 3 x 8
7-682-546-15	(+) B 3 x 5	7-682-160-01	(+) P 4 x 6
7-682-548-05	(+) B 3 x 8	7-682-161-13	(+) P 4 x 8
7-682-568-04	(+) B 4 x 30	7-682-645-13	(+) PS 3 x 4
7-682-589-01	(+) PS 3 x 8	7-682-647-01	(+) PS 3 x 6
7-682-647-01	(+) PS 3 x 6 (with spring washer)	7-682-648-01	(+) PS 3 x 8
7-682-661-01	(+) PS 4 x 8 (with spring washer)	7-682-649-01	(+) PS 3 x 10
7-682-147-14	(+) P 3 x 6 (connector panel, hinge)	7-682-663-01	(+) PS 4 x 12
	<u>WASHERS</u>	7-682-665-01	(+) PS 4 x 16
7-623-105-22	2 mm dia (large)		<u>WASHERS</u>
7-623-107-22	2.6 mm dia (large)	7-623-105-02	2 ϕ (small)
7-623-108-12	3 mm dia (medium)	7-623-107-12	2.6 ϕ (medium)
7-623-110-12	4 mm dia (medium)	7-623-108-12	3 ϕ (medium)
7-623-112-12	5 mm dia (medium)	7-623-110-12	4 ϕ (medium)
7-623-113-12	6 mm dia (medium)	7-623-112-12	5 ϕ (medium)
7-623-207-22	Spring Washer, 2.6 mm dia	7-623-212-22	Spring Washer, 5 ϕ
7-623-208-22	Spring Washer, 3 mm dia		
7-623-210-22	Spring Washer, 4 mm dia		
7-623-407-05	Star Washer, external, 2.6 mm dia		
7-623-408-05	Star Washer, external, 3 mm dia		
7-623-908-02	Fiber Washer, 3 mm dia		
7-623-908-04	Plastic Washer, 3 mm dia		
7-624-102-01	E Washer, 1.5		

Part No. Description

BOLT

7-683-437-01 5 x 4

NUT

7-684-015-01 5 φ

SUPPLEMENT

SUBJECT: Picture Resolution Up and Audio Manual Control

No. 1
AUG. '71

APPLICABLE

SERIAL NUMBER: Picture Resolution Up 39,601 and later
Audio Manual Control 52,101 and later

1. MODIFICATIONS

1-1. Picture Resolution Up

The following changes have been made on the machine, to assure the picture resolution better than 300 lines and to improve the picture quality.

- (1) To change the time-constant of the low-pass filter in the Modulator Drive Amplifier (V2 board), for the wider frequency response in high frequency range.
- (2) To change the time-constant of the low-pass filter in the next stage of the Demodulator Circuit, for the wider frequency response in high frequency range.
- (3) To shift up the FM Carrier Frequency for 100 kHz.
Sync Tip frequency
..... from 3.2 MHz to 3.3 MHz
White Peak frequency
..... from 4.6 MHz to 4.7 MHz
- (4) To add to the Video Output Amplifiers (Q307/Q308) in V1 board, a compensation circuit for middle frequency range (1.6 MHz to 2 MHz).
- (5) To rise up the frequency response of the PB Amplifier (V2 board) for about 2 dB, which has been flat up to high frequency.
- (6) To decrease the Dark Clip Level from 50% to 30%.

1-2. Audio Manual Control

AUDIO MANUAL Function is featured additionally to the AGC Operation.

- (1) The "A BOARD" is replaced by the "A BOARD" used in AV-3650.
- (2) An Audio Level Meter, Audio Level Control and AGC ↔ MANUAL Selection Switch are added.

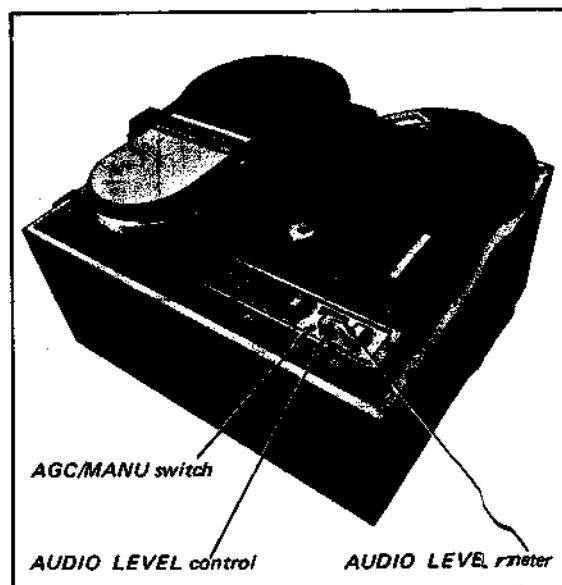

2. ADJUSTMENT

The following adjustment are changed.

- Sec. 5. VIDEO SYSTEM ALIGNMENT
 - 5-1. Maximum Deviation Adjustment
 - 5-4. Playback Preamp Amplifier Adjustment
- Sec. 7. AUDIO SYSTEM ALIGNMENT

5-1. Maximum Deviation Adjustment

"Adjust for: 1.0 V (p-p) video output with 3.3 MHz to 4.7 MHz modulator input."

Procedure A: (page 5-2)

- "6. Adjust R126 (Sync Tip Carrier Freq.) for 3.3 MHz as indicated on the scope screen.
 - a. Adjust scope time base for 1 μ sec per division (calibrated).
 - b. Set scope controls to obtain a stable trace. A correct carrier frequency of 3.3 MHz is indicated when there are 33 complete square waves in ten divisions. Set R126 to produce this indication".
- "12. Adjust R155 so that the negative spike in the vertical blanking pulse falls 30% below sync tip amplitude. See Fig. 5-1b."

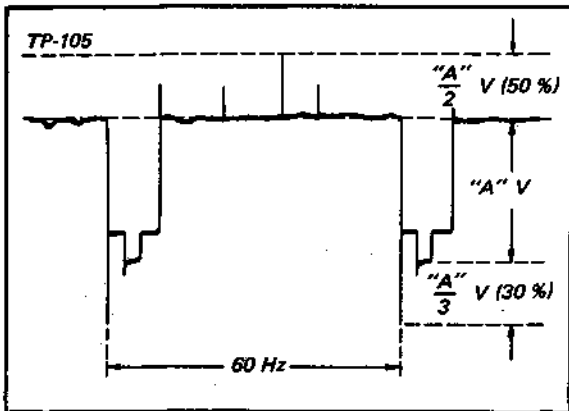

Fig. 5-1b. White clip and dark clip levels

Procedure B: (page 5-3)

- "5. Adjust R126 (Sync Tip Carrier Freq.) for a stable trace of 3.3 MHz."
- "6. This trace indicates the dc level of the modulator input required to produce 3.3 MHz at the modulator output."
- "7. Readjust R126 for 4.7 MHz as indicated on the scope. A correct frequency of 4.7 MHz is indicated when there are 23.5 square waves in ten divisions when the time-base is set to 0.5 μ sec/cm."

- "12. Make sure that a carrier frequency of about 3.7 MHz is indicated on the scope with no signal input."

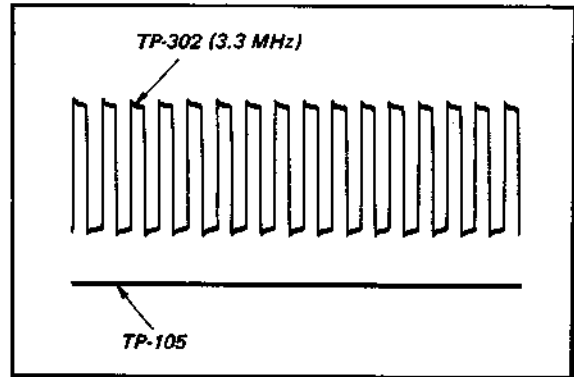

Fig. 5-2a. Waveforms in Steps 5 and 6

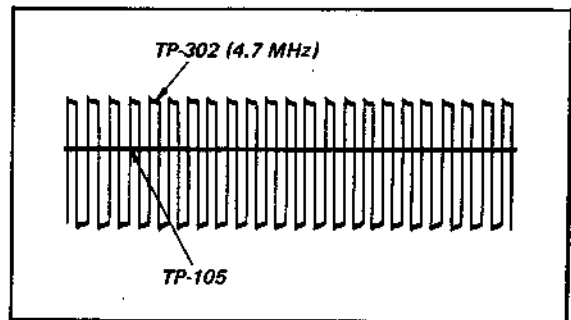

Fig. 5-2b. Waveforms in Steps 7 and 8

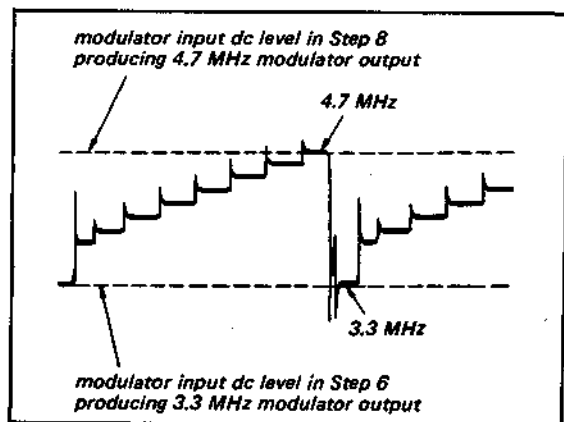

Fig. 5-2c. Maximum deviation setting

5-4. Playback Preamplifier Adjustment

(Head Resonance and Playback Equalization)

Frequency characteristics of the playback amplifiers are adjusted to equalize head-to-tape characteristics and to obtain the desired overall frequency response.

Test Point/

Board: TP-201/V2 (PB rf output)

Adjust for: Correct frequency response as shown in Fig. 5-5.

Adjustment/

Board: C201, R201/V2 (Head Resonance, Ch A)
C202, R202/V2 (Head Resonance, Ch B)
L204/V2 (PB Equalization)
R211/V2 (PB Equalization)

Equipment

Required: (1) Oscilloscope
(2) SONY Alignment Tape

Procedure:

1. Playback the rf sweep portion of the SONY alignment tape.

2. Connect the scope to TP201/V2 Board. Sync the scope externally from TP-412/SV Board. Set the scope time base to 5 msec/cm. Four markers in the playback rf signal indicate the 1 MHz, 2 MHz, 3.58 MHz, and 4.5 MHz points.
3. Set R201 (resonance gain) fully clockwise. Set R202 (resonance gain) fully clockwise. Adjust C201 (Ch A) and C202 (Ch B) for resonant frequency of 5 MHz.
4. Adjust R201 for Ch A (R202 for Ch B) so that the amplitude at 5 MHz is equal to that at 2 MHz. See Fig. 5-5 (a).
5. Turn R211 (equalizing gain) fully counter-clockwise. Set the equalizing frequency to 3.58 MHz by turning L204.
6. Adjust R211 and R201 for Ch A (R202 for Ch B) to obtain a rf envelope approximately flat from 2 MHz up to 5 MHz. See Fig. 5-5 (a).
7. Set R211 so that the ratio B/A is 125% \pm 10%
 - A the amplitude at 2 MHz
 - B the amplitude at 3.58 MHz

See Fig. 5-5 (b).

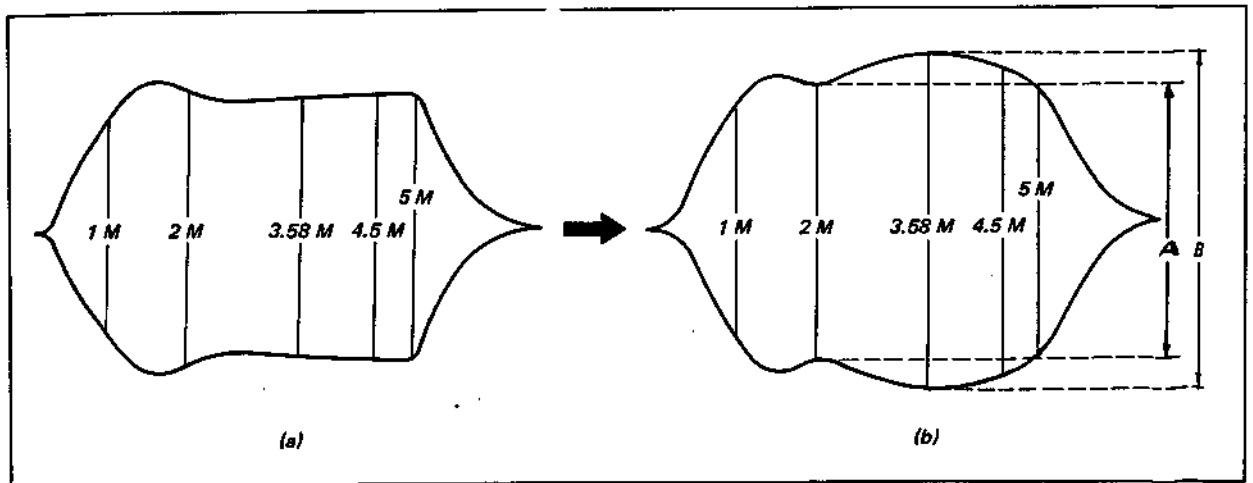

Fig. 5-5. Playback rf signal

SECTION 7

AUDIO SYSTEM ALIGNMENT

7-1. Audio Head Azimuth Adjustment

1. Connect a scope or a VTVM to TP-502 on the A Board.
2. Play back the 7 kHz part of the SONY alignment tape.
3. Adjust the Azimuth and Tilt Adjusting Screws shown in Fig. 7-1 for maximum output.

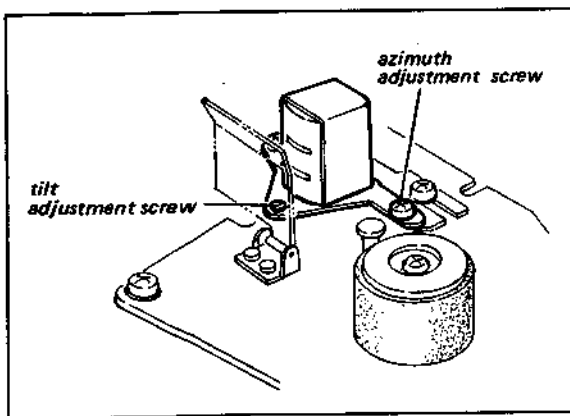

Fig. 7-1. Audio/CTL head azimuth and tilt adjustments

7-2. Level Meter Setting

1. Set the VTR to Manual in the E-to-E mode.
2. Feed a 1 kHz signal, -65 dB to the MIC IN jack in CAMERA or LINE mode or a 1 kHz signal, 0 dB to the AUX IN jack. Terminate the LINE OUT jack with a 10 k Ω resistor and connect a VTVM. Adjust the LEVEL control on the control panel so that the LINE OUT level is 0 dB.
3. Adjust R532 so that the pointer of the level meter reads on the right edge of the black zone, as shown in Fig. 7-2.

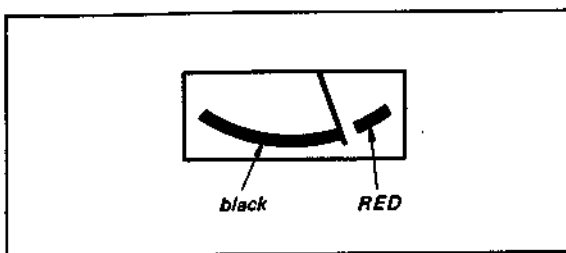

Fig. 7-2. Meter setting

7-3. Agc Level Setting

1. Set the VTR to AGC in the E-to-E mode.
2. Terminate the LINE OUT jack with a 10 k Ω resistor and connect a VTVM.
3. Feed a 1 kHz signal, -65 dB to the MIC IN jack in the CAMERA or LINE mode or a 1 kHz signal, 0 dB to the LINE IN jack.
4. Adjust R533 to obtain a meter reading of 0 dB.

7-4. Audio Bias Setting

1. Feed a 1 kHz, -65 dB signal to the MIC IN jack or a 1 kHz, 0 dB signal to the LINE IN jack.
2. Thread a tape onto the Videocorder. Connect a camera and a monitor to the recorder and a VTVM to TP-504 on the A Board.
3. Point the camera at the VTVM so that the meter indications is visible on the monitor in the Record mode.
4. Make a recording of the input audio signal while varying C530 (on the A Board) throughout its range very slowly.
5. Rewind and play back the tape. Watching the monitor, note the level on the meter (the playback picture) at which output is greatest, as indicated by the playback sound level.
6. Set the VTR to the Record mode again and adjust C530 for the reading that gave maximum output during playback.
7. Set the VTR to the Audio Dub mode and adjust L401 on the SV Board for the same reading (at TP-504/ A Board) that gave maximum output during playback.

7-5. Playback Level Setting

1. Connect the VTVM to the LINE OUT jack using a 10 k Ω load resistor.
2. Play back the 1 kHz part of the SONY Alignment tape and adjust R519 so that the line out level is 0 dB.

7-6. Overall Frequency Characteristics

1. Connect the VTVM to the LINE OUT jack using a 10 k Ω load resistor.
2. Feed a 1 kHz signal, -65 dB to the MIC IN jack and make a recording. Play back the tape and

confirm that the output is $0 \text{ dB} \pm 2 \text{ dB}$.

3. Record 100 Hz and 10 kHz, -65 dB signals and play back the tape. Check that the frequency response conforms to the following specifications. If it does not, adjust R515. Repeat Section 7-5. **PLAYBACK LEVEL SETTING.**

Specifications: 1 kHz $0 \text{ dB} \pm 2 \text{ dB}$
 100 Hz more than -6 dB
 10 kHz more than -6 dB

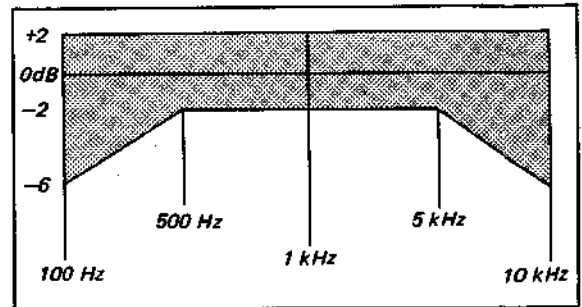

Fig. 7-3.

3. CHANGED AND ADDED PARTS

3-1. Electrical Parts

V1 Board

Ref. No.	Remarks	New Parts		Original Parts
		Description	Part No.	
R355	Added	33Ω	1-244-637-11	
R356	Added	270Ω	1-242-659-11	
C326	Added	300 pF	1-107-142-11	
C327	Added	82 pF	1-107-083-11	
C318	Changed	82 pF	1-107-083-11	91 pF
C319	Changed	82 pF	1-107-083-11	91 pF
L301	Changed	$39 \mu\text{H}$	1-407-164-11	$47 \mu\text{H}$
L302	Changed	$39 \mu\text{H}$	1-407-164-11	$47 \mu\text{H}$
L303	Changed	$39 \mu\text{H}$	1-407-164-11	$47 \mu\text{H}$
L304	Changed	$39 \mu\text{H}$	1-407-164-11	$47 \mu\text{H}$
L305	Added	$82 \mu\text{H}$	1-407-168-11	
Q301	Changed	2SC403B		2SC403A
Q302	Changed	2SC403B		2SC403A
Q303	Changed	2SC403B		2SC403A
Q304	Changed	2SC403B		2SC403A
Q305	Changed	2SC403B		2SC403A
Q306	Changed	2SC403B		2SC403A
Q307	Changed	2SC403B		2SC403A
Q308	Changed	2SC403B		2SC403A

V2 Board

Ref. No.	Remarks	New Parts		Original Parts
		Description	Part No.	
R151	Changed	200 Ω	1-242-656-11	270 Ω
R156	Added	1 k Ω	1-244-673-11	
C113	Changed	62 pF	1-107-080-11	91 pF
C114	Added	62 pF	1-107-080-11	
C117	Changed	47 μ F, 25 V	1-121-410-11	47 μ F, 16 V
C120	Changed	56 pF	1-107-125-11	68 pF
C121	Changed	47 pF	1-107-123-11	56 pF
C127	Added	0.047 μ F	1-105-841-12	
L102	Changed	33 μ H	1-407-163-11	47 μ H
L103	Changed	33 μ H	1-407-163-11	47 μ H
L104	Added	33 μ H	1-407-163-11	
L105	Added	33 μ H	1-407-163-11	
D105	Changed	1S1925		1S1555
D106	Changed	1S1925		1S1555
Q102	Changed	2SC403B		2SC403A
Q103	Changed	2SC403B		2SC403A
Q104	Changed	2SC403B		2SC403A
Q105	Changed	2SC403B		2SC403A
Q106	Changed	2SA564A		2SA611
Q107	Changed	2SA564A		2SA611
Q108	Changed	2SC403B		2SC403A
Q109	Changed	2SC403B		2SC403A
Q110	Changed	2SC403B		2SC403A
Q203	Changed	2SC403B		2SC403A
Q204	Changed	2SC403B		2SC403A
Q207	Changed	2SC403B		2SC403A
Q208	Changed	2SC403B		2SC403A
Q209	Changed	2SC403B		2SC403A
Q211	Changed	2SC403B		2SC403A

SV Board

Ref. No.	Remarks	New Parts		Original Parts
		Description	Part No.	
R439	Changed	2200 Ω	1-242-681-11	1 k Ω
R442	Changed	56 k Ω	1-242-715-11	47 k Ω
R444	Changed	2200 Ω	1-242-681-11	1 k Ω
R445	Changed	680 Ω , 1/2W	1-250-869-11	330 Ω
R446	Changed	4700 Ω	1-242-689-11	10 k Ω
R447	Changed	6200 Ω	1-242-692-11	4700 Ω
R456	Added	680 Ω	1-244-669-11	
C432	Changed	0.22 μ F	1-105-849-12	0.1 μ F
Q402	Changed	2SA564A		2SA611
Q404	Changed	2SA564A		2SA611

Ref. No. Part No. Description Ref. No. Part No. Description

TRANSISTORS

Q501 2SC631
 Q502 2SC631
 Q503 2SC634A
 Q504 2SC634A
 Q505 2SC634A
 Q506 2SC634A
 Q507 2SC634A
 Q508 2SC634A
 Q509 2SC403C

RESISTORS

All resistors in ohms, $\pm 5\%$, $\frac{1}{4}W$, fixed carbon, unless otherwise indicated. (k = 1000, M = 1000 k)

R501 1-242-668-11 620
 R502 1-242-713-11 47 k
 R503 1-242-697-11 10 k
 R504 1-242-693-11 6800
 R505 1-242-713-11 47 k
 R506 1-242-661-11 330
 R507 1-242-685-11 3300
 R508 1-242-720-11 68 k
 R509 1-242-713-11 47 k
 R510 1-242-681-11 2200
 R511 1-242-705-11 22 k
 R512 1-242-683-11 2700
 R513 1-242-709-11 33 k
 R514 1-242-723-11 120 k
 R515 1-221-498-11 10 k, adjustable
 R516 1-242-721-11 100 k
 R517 1-242-715-11 56 k
 R518 1-242-715-11 56 k
 R519 1-221-496-11 2 k, adjustabel

R520 1-242-680-11 2 k
 R521 1-242-697-11 10 k
 R522 1-242-735-11 390 k
 R523 1-242-707-11 27 k
 R524 1-242-723-11 120 k
 R525 1-242-663-11 390
 R526 1-242-683-11 2700
 R527 1-242-677-11 1500
 R528 1-242-713-11 47 k
 R529 1-242-656-11 200
 R530 1-242-661-11 330
 R531 1-242-673-11 1 k
 R532 1-221-498-11 10 k, adjustable
 R533 1-221-681-11 50 k, adjustable
 R534 1-221-713-11 47 k
 R535 1-242-709-11 33 k
 R536 1-242-694-11 7500
 R538 1-242-735-11 390 k
 R539 1-242-714-11 51 k
 R540 1-242-689-11 4700
 R541 1-242-669-11 680
 R542 1-242-681-11 2200
 R543 1-242-704-11 20 k
 R544 1-244-860-11 300
 R545 1-242-707-11 27 k
 R546 1-242-675-11 1200
 R547 1-242-609-11 2.2
 R548 1-242-691-11 5600
 R549 1-244-860-11 300

SWITCH

SW8 1-514-454 SLIDE SWITCH

TRANSFORMER

T501 1-433-137 TRANSFORMER, oscillator

Frame

Ref. No.	Remarks	New Parts	
		Description	Part No.
VR003	Added	10 k Ω , adjustable	1-222-559-11
CN8	Changed	UHF Connector	1-509-158-13
CN9	Changed	UHF Connector	1-509-158-13
SW10	Added	Push Switch	1-513-149-00
SW9	Changed	Leaf Switch	1-514-924-11
	Added	Level Meter	1-520-103
	Changed	REC Lamp	1-518-082-11
	Changed	Pilot Lamp	1-518-082-21
	Changed	Terminal Strip, 5-pin	1-536-278-11
	Added	Terminal Strip, 1L2	1-536-180-11

3-2. Mechanical Parts

Part No.	Description	Part No.	Description
X-36210-14	CLUTCH ASS'Y (B), skew control	3-621-076	SHAFT (B), skew control knob
X-36210-15	GUARD, video head	3-621-086	ORNAMENTAL PLATE, pushbutton escutcheon
X-36210-17	PULLY ASS'Y, tape counter	3-621-087	BRACKET, meter
X-36210-18	PUSH BUTTON ASS'Y	3-621-088	BRACKET, lamp
X-36210-19	SHAFT ASS'Y (E), rewind idler	3-621-089	BRACKET, leaf switch
X-36250-03	KNOB ASS'Y, control	3-621-090	CAM, leaf switch
X-36250-10	PINCH LEVER ASS'Y	3-621-094	FELT, pushbutton
3-607-104-02	BRUSH	3-621-512-04	PANEL, connector
3-613-189-04	ESCUTCHEION, pushbutton	3-612-513-02	ORNAMENTAL PLATE, connector panel
3-621-042-04	CASE, RF adaptor	3-625-095	RETAINER, lamp
3-621-047	BEARING, capstan shaft	3-625-142	CUSHION, meter
3-621-055-03	PANEL (A), reel	3-790-680-32	INSTRUCTION MANUAL
3-621-064-02	CARTON	3-793-218-32	INSTRUCTION CARD
3-621-073-02	GEAR (A), skew control		
3-621-075	BRACKET (B), skew control		

4. EXPLODED VIEW

1. Reel Panel

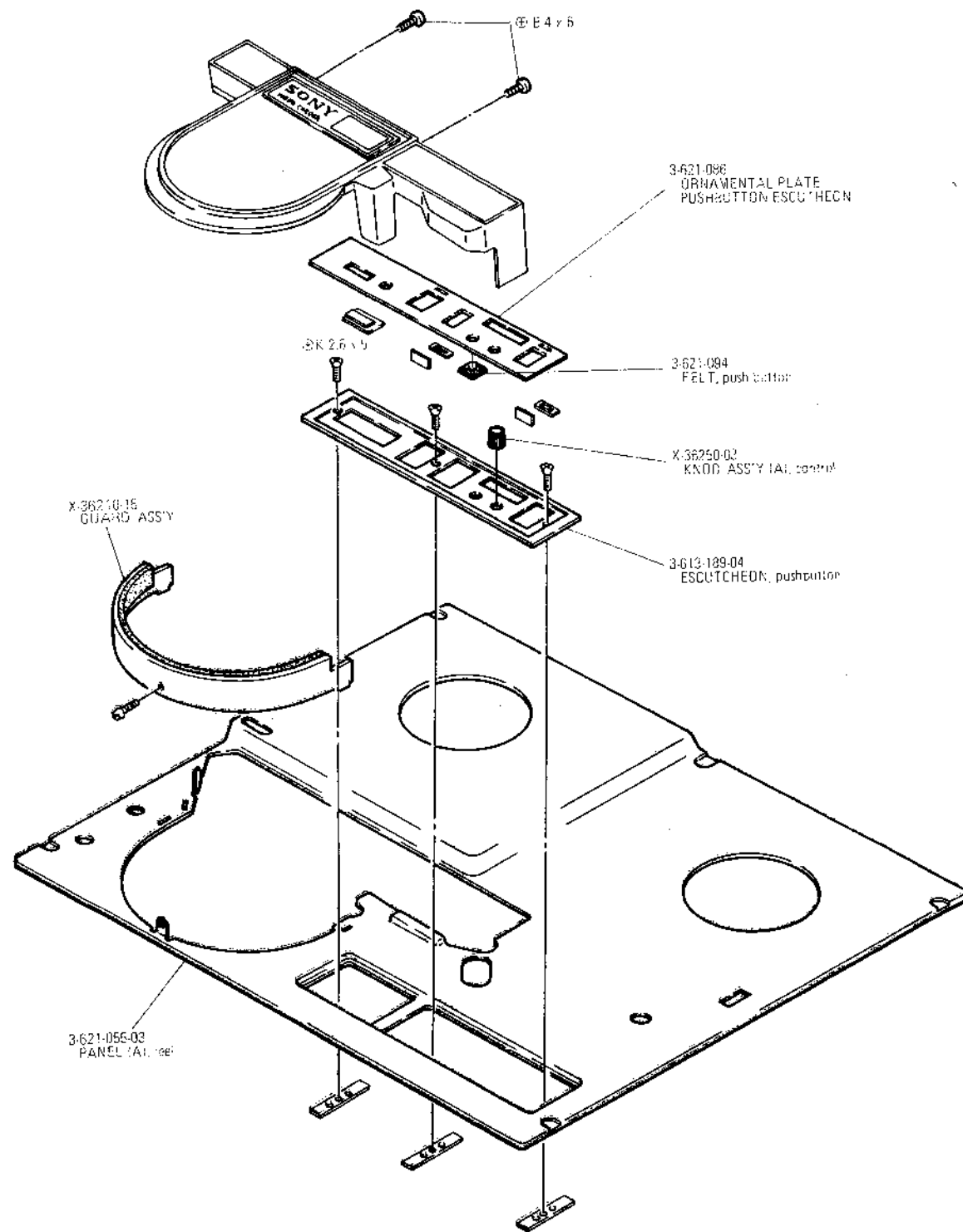

2. Meter & Pilot Lamp

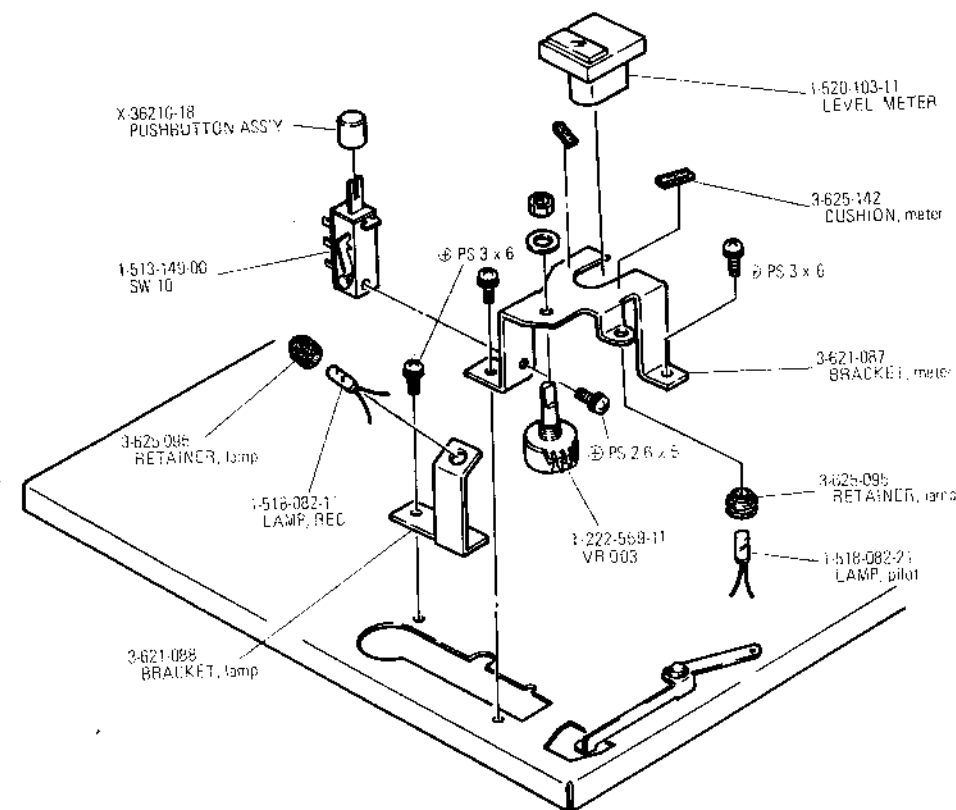

5. PRINTED CIRCUIT BOARD AND SCHEMATIC DIAGRAMS

V1 LIMITER & DEMOD PRINTED CIRCUIT BOARD

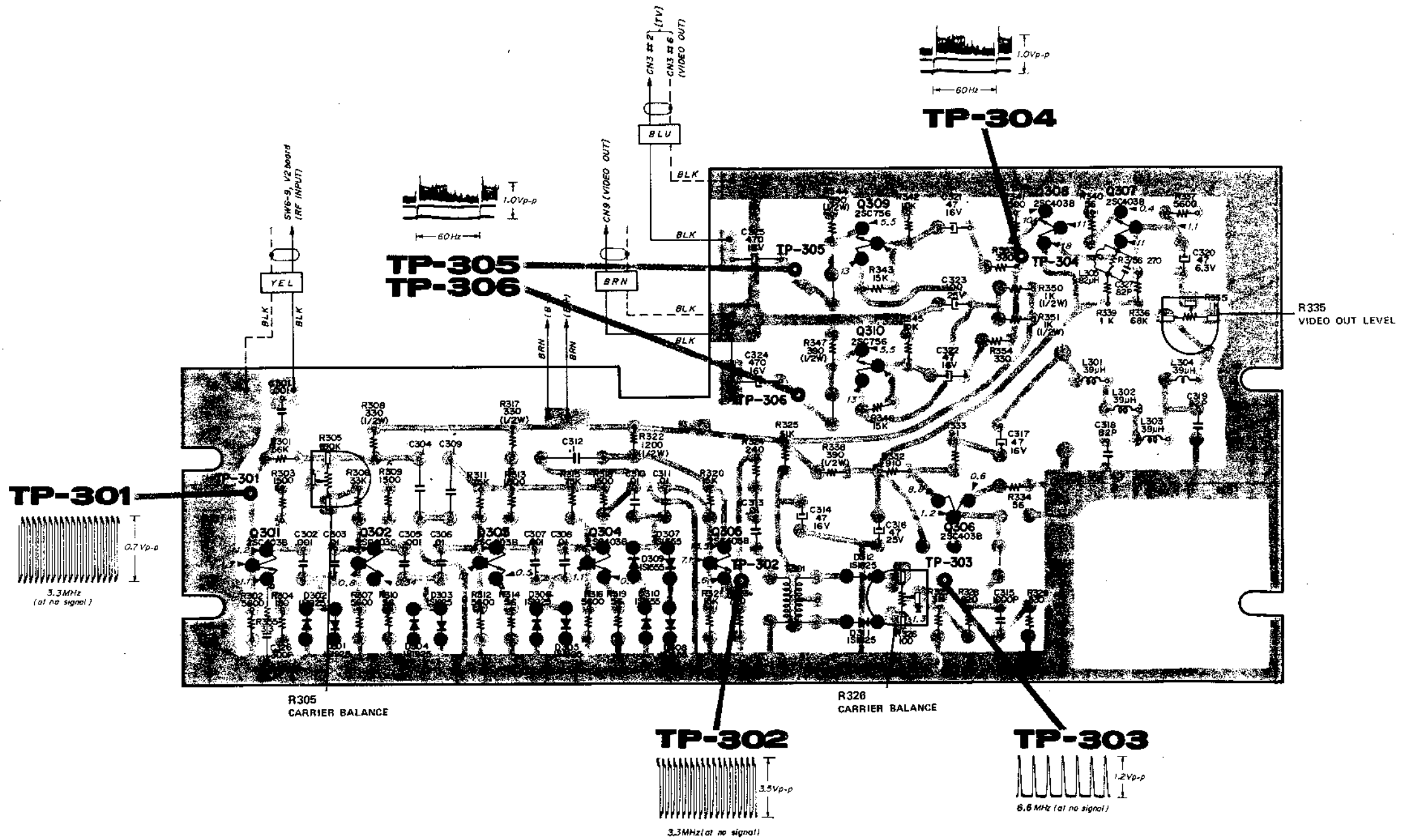

V2 MOD & REC/PB AMP PRINTED CIRCUIT BOARD

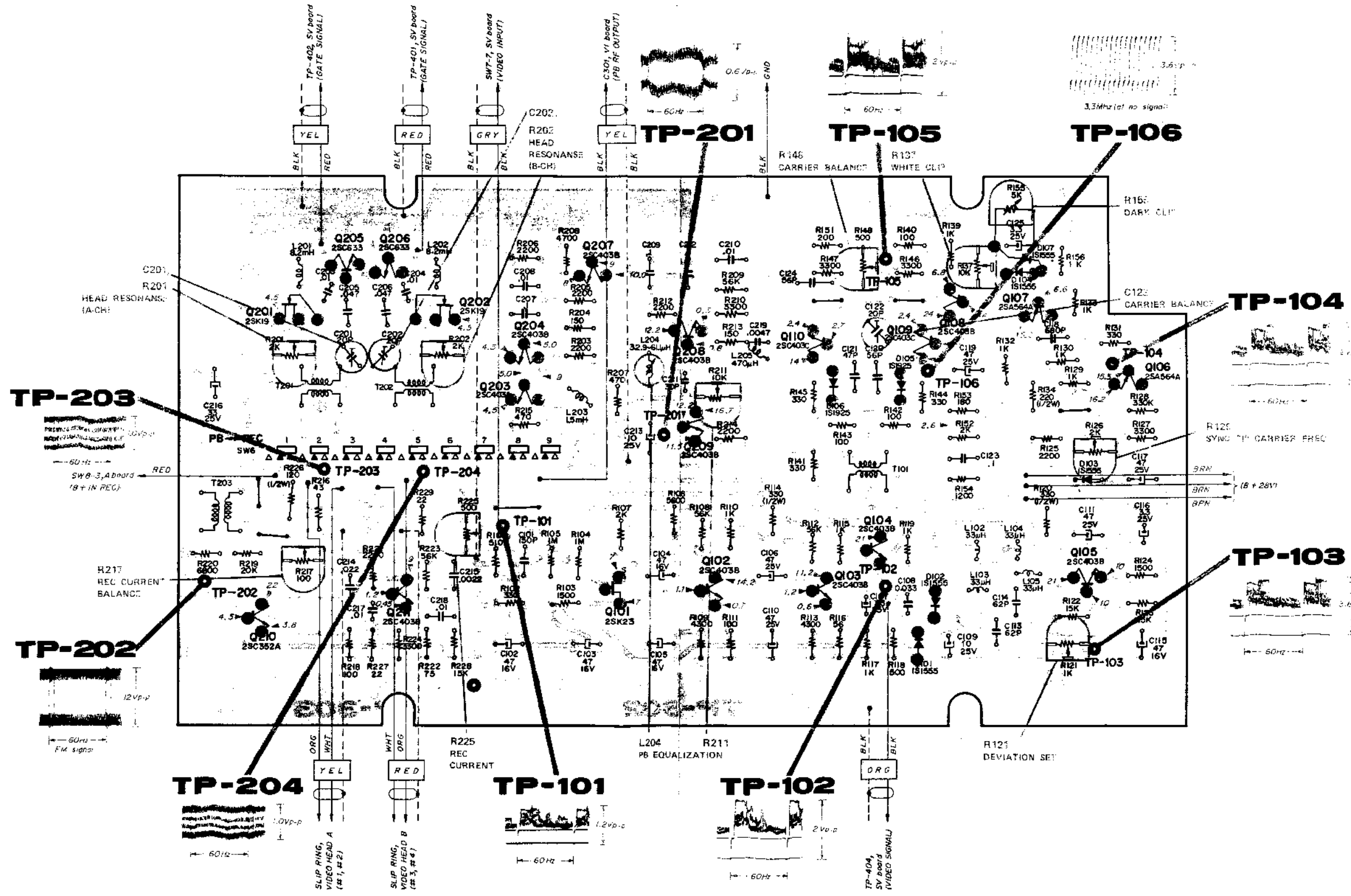

SV SERVO PRINTED CIRCUIT BOARD

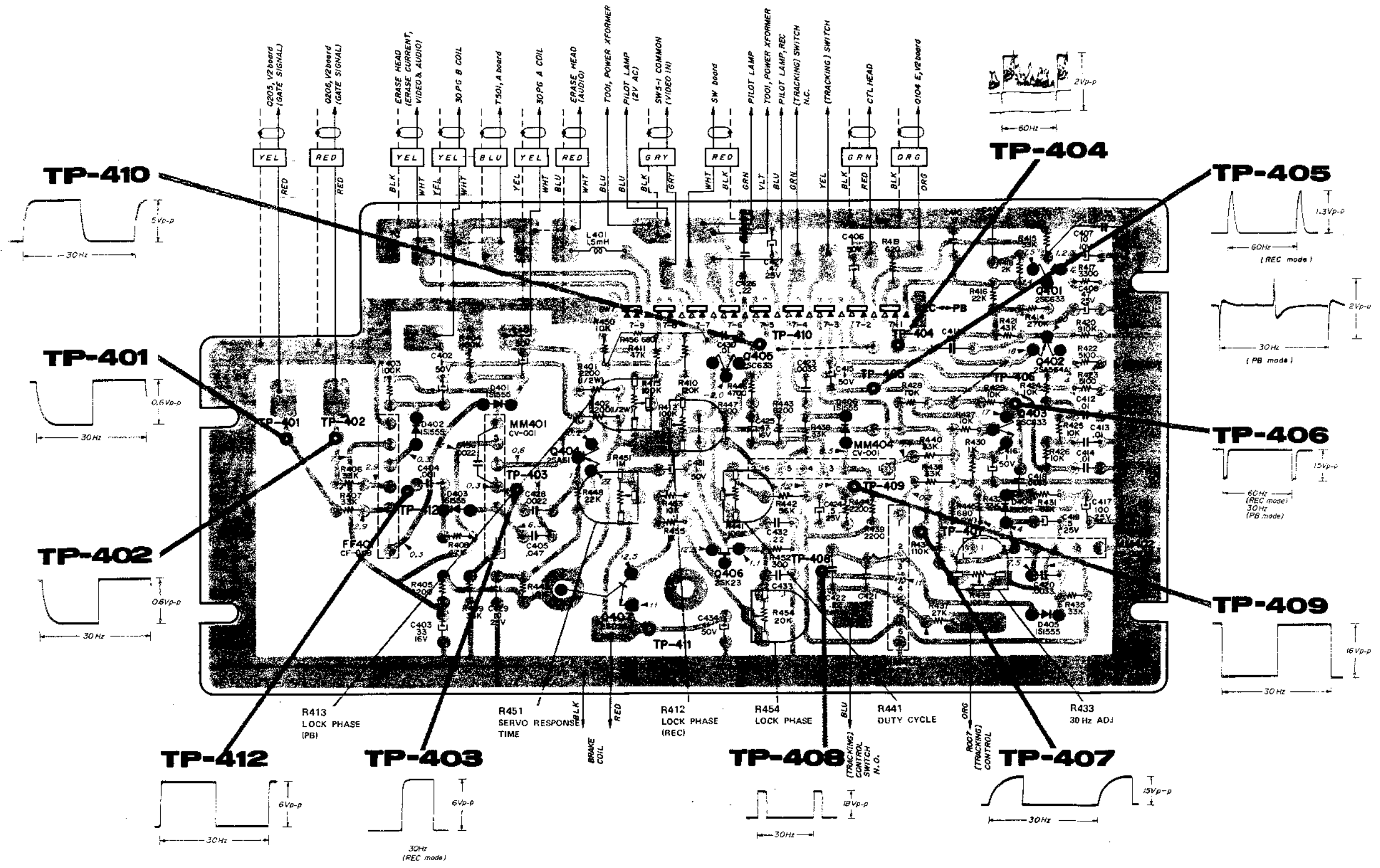

R2 VOLTAGE REGULATOR PRINTED CIRCUIT BOARD

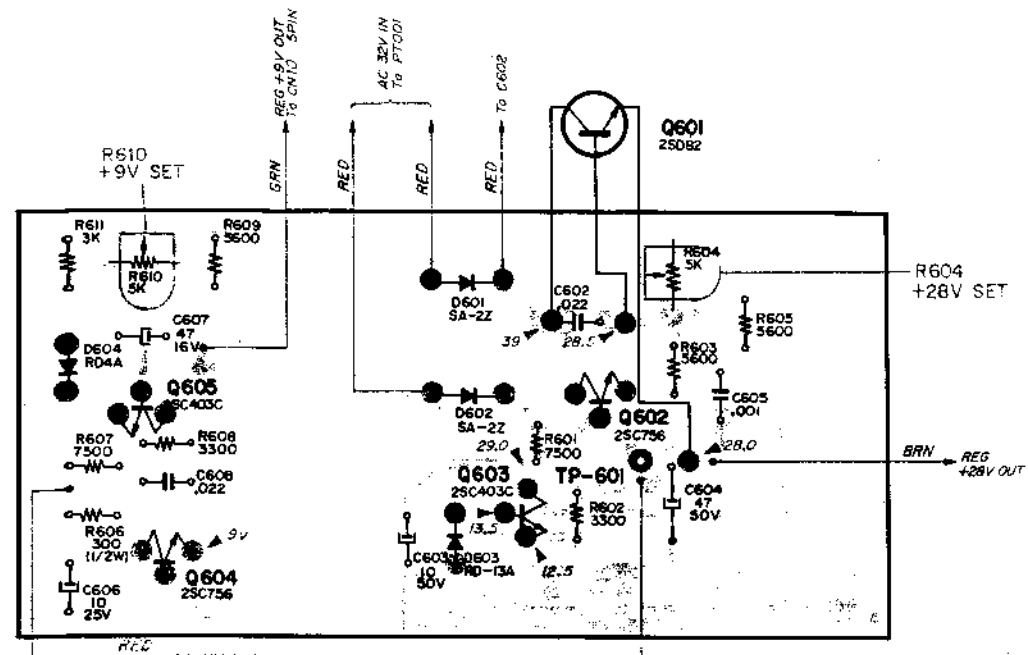

SY3 VERTICAL SYNC FORMER PRINTED CIRCUIT BOARD

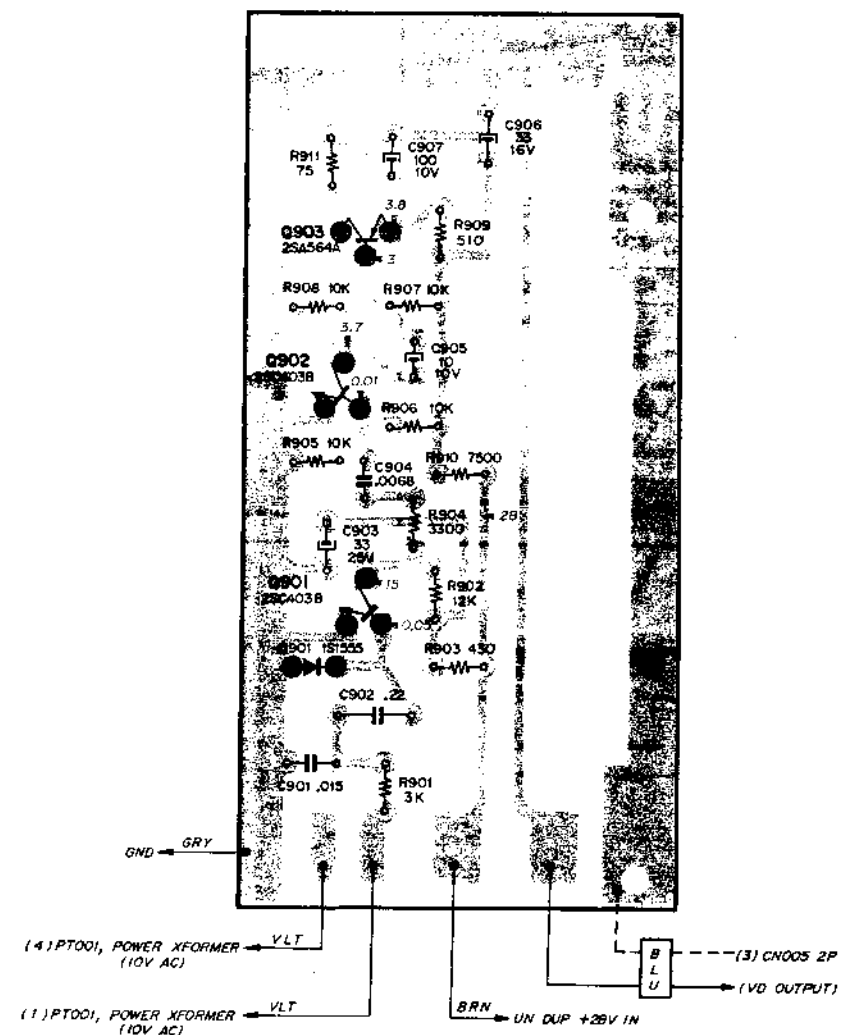

A AUDIO PRINTED CIRCUIT BOARD

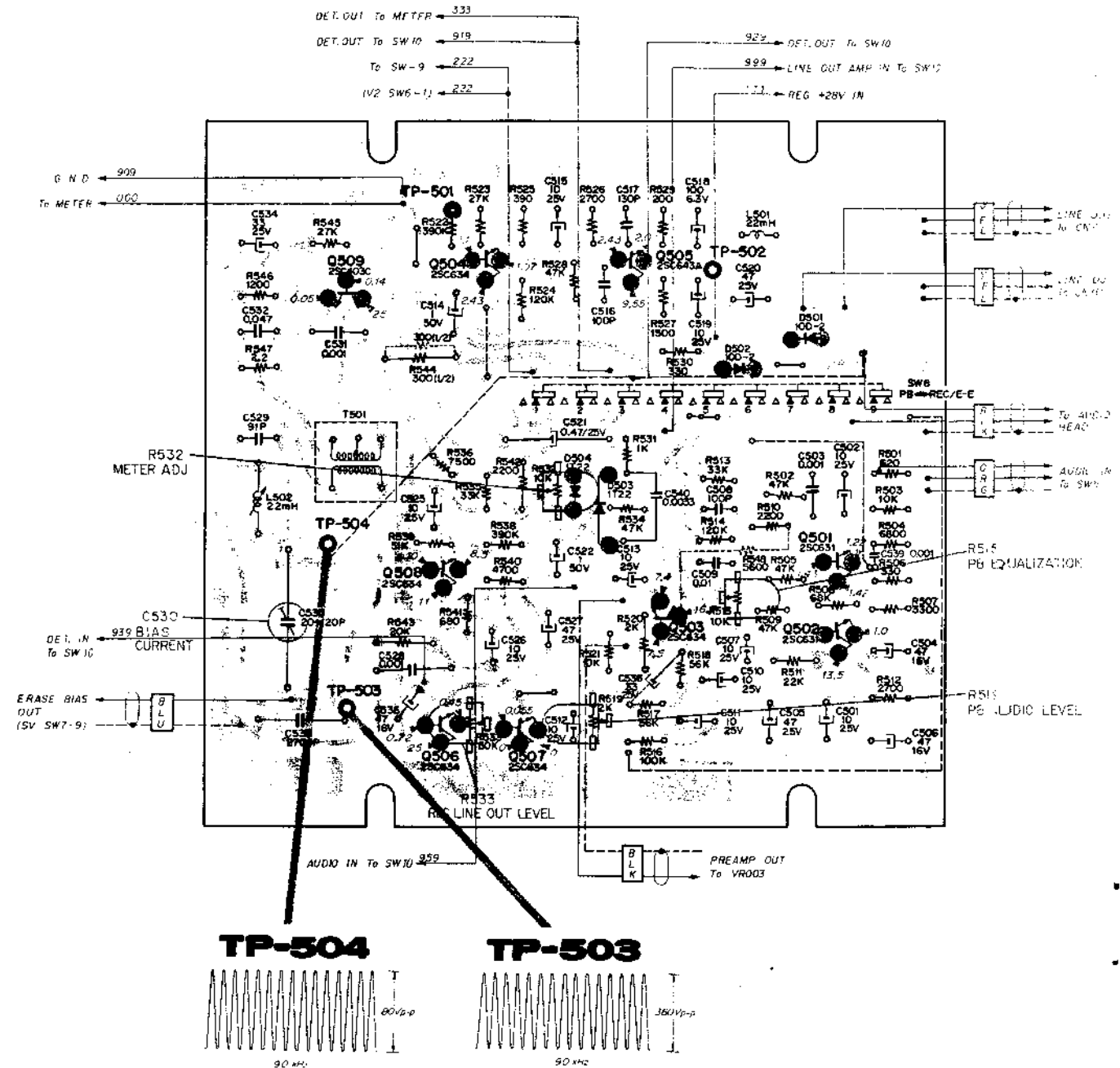

OVERALL SCHEMATIC DIAGRAM

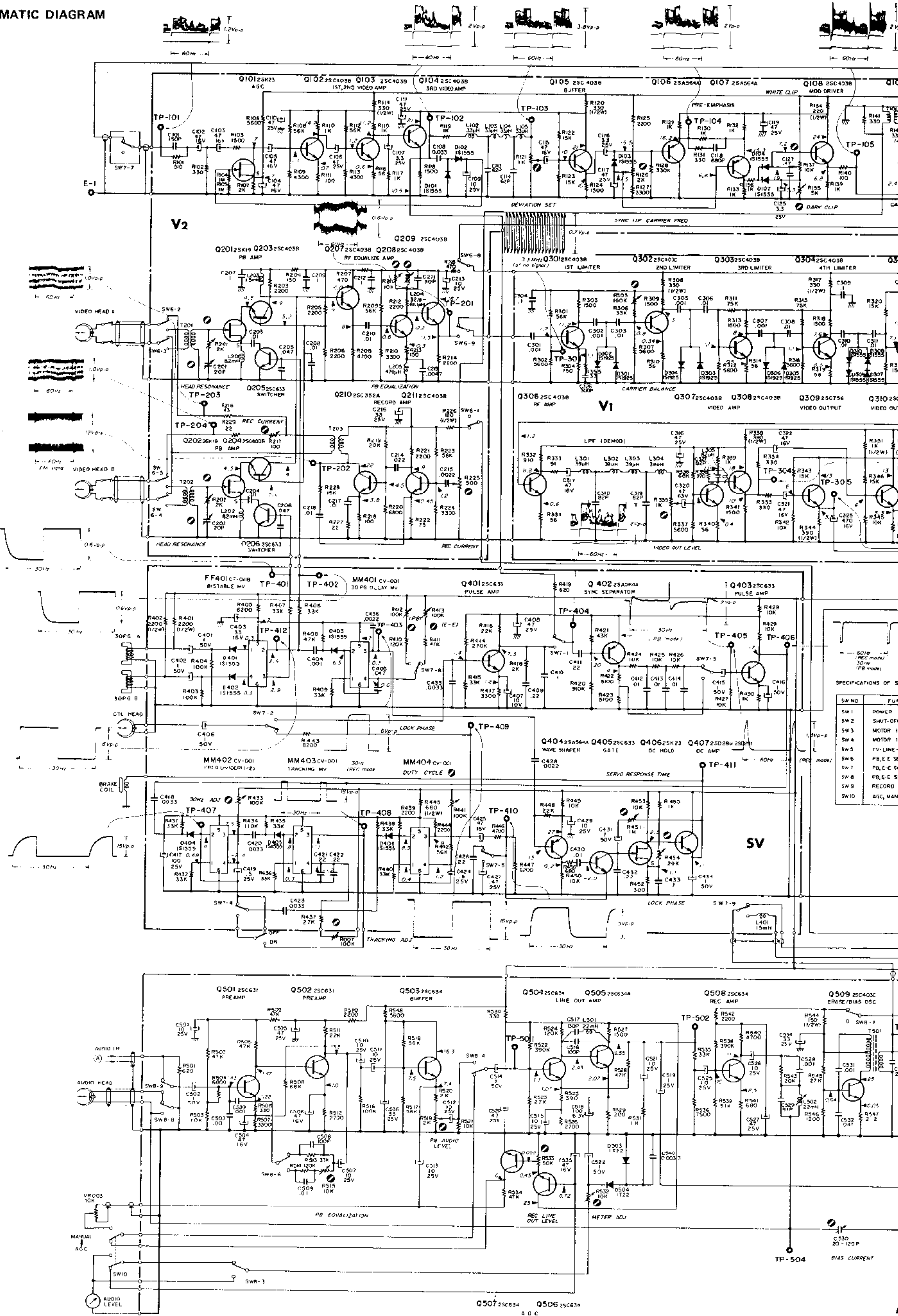

SPECIFICATIONS OF S

SW NO	FUN
SW 1	POWER
SW 2	SHUT-OFF
SW 3	MOTOR II
SW 4	MOTOR I
SW 5	TV-LINE
SW 6	PB, E, S
SW 7	PB, E, S
SW 8	PB, E, S
SW 9	RECORD
SW 10	AGC, MAN

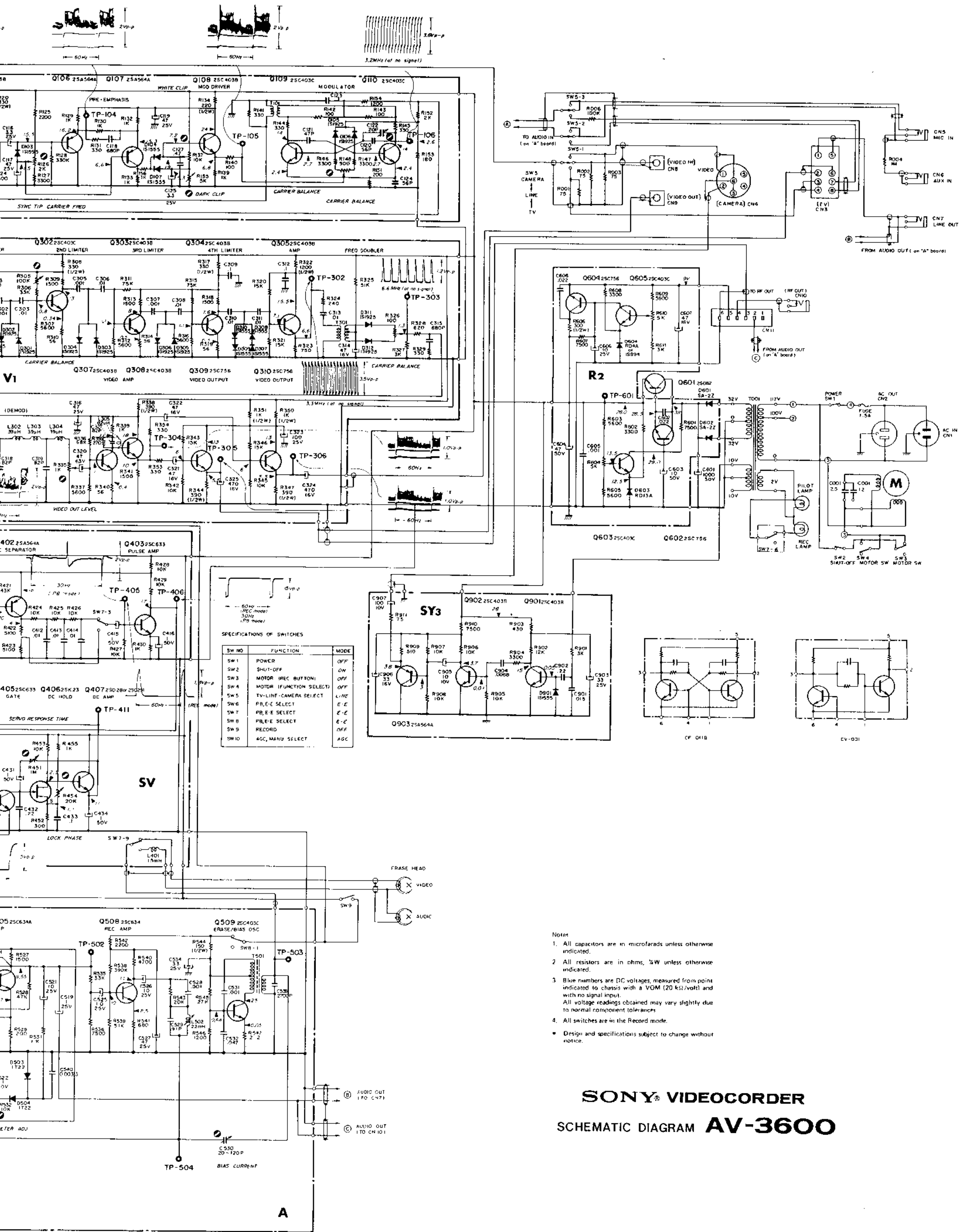

SONY® VIDEORECORDER
SCHEMATIC DIAGRAM AV-3600