

Specifications

Circuit :	11 Transistor Superheterodyne
Frequency Coverage :	FM 86.5~108 Mc (3.47~2.78 m) LW 150~285 Kc (1,000~1,053 m) MW 530~1,605 Kc (1,566~187 m) SW 5.9~12 Mc (50.8~25 m)
Antenna System :	Built-in Ferrite Bar Antenna (LW, MW) Built-in Telescopic Antenna (FM, SW) Car Antenna Coil (FM, AM)
Intermediate Frequency :	FM 10.7 Mc, AM 455 Kc
Maximum Sensitivity :	Portable Car
(at 50 mW output with 7 dB S/N)	FM 5.5 dB 5.5 dB LW 44 dB 26 dB MW 37 dB 24 dB SW 12 dB 17 dB
Selectivity :	30 dB at 10 Kc off resonance, at 1,400 Kc
Power Output :	450 mW (undistorted) 730 mW (maximum)
Current Drain :	21 mA at zero signal, 200 mA at 450 mW output
Speaker :	12 cm (5"), PM dynamic, 8Ω
Power Source :	Three Size "D" Flashlight Batteries, 4.5 V in total
Dimensions :	205 (H) × 203 (W) × 65 (D) mm (8-1/16 × 8 × 2-9/16")
Weight :	1.9 Kg. (4 lbs. 3 ozs.)

Adjustments

a) Frequency Coverage Adjustment

	Lower Limit	Adjust	Upper Limit	Adjust
FM	85.5 Mc	Core and Gap of FM OSC Coil (L ₁₀₄)	109.5 Mc	FM OSC Trimmer (C ₁₋₄)
LW	145 Kc	Core of LW OSC Coil (L ₂₀₇)	300 Kc	LW OSC Trimmer (C ₂₋₆)
MW	520 Kc	Core of MW OSC Coil (L ₂₀₅)	1,680 Kc	MW OSC Trimmer (C ₂₋₇)
SW	5.75 Mc	Core of SW OSC Coil (L ₂₀₀)	12.6 Mc	SW OSC Trimmer (C ₂₋₉)

b) Tracking Adjustment

	Lower Checking Point	Adjust	Upper Checking Point	Adjust
FM	85.5 Mc	Core of FM RF Coil (L ₁₀₂)	109.5 Mc	FM RF Trimmer (C ₁₋₃)
LW	160 Kc	Position of LW ANT Coil (L ₂₀₁)	280 Kc	LW ANT Trimmer (C ₂₋₃)
		Core of LW Car ANT Coil (L ₂₀₄)		LW Car ANT Trimmer (C ₂₋₉)
MW	620 Kc	Position of MW ANT Coil (L ₂₀₂)	1,400 Kc	MW ANT Trimmer (C ₂₋₄)
		Core of MW Car ANT Coil (L ₂₀₅)		MW Car ANT Trimmer (C ₂₋₁₀)
SW	5.75 Mc	Core of SW ANT Coil (L ₂₀₀)	12.6 Mc	SW ANT Trimmer (C ₂₋₅)
		Core of SW Car ANT Coil (L ₂₀₆)		SW Car ANT Trimmer (C ₂₋₁₁)

Schematic Diagram

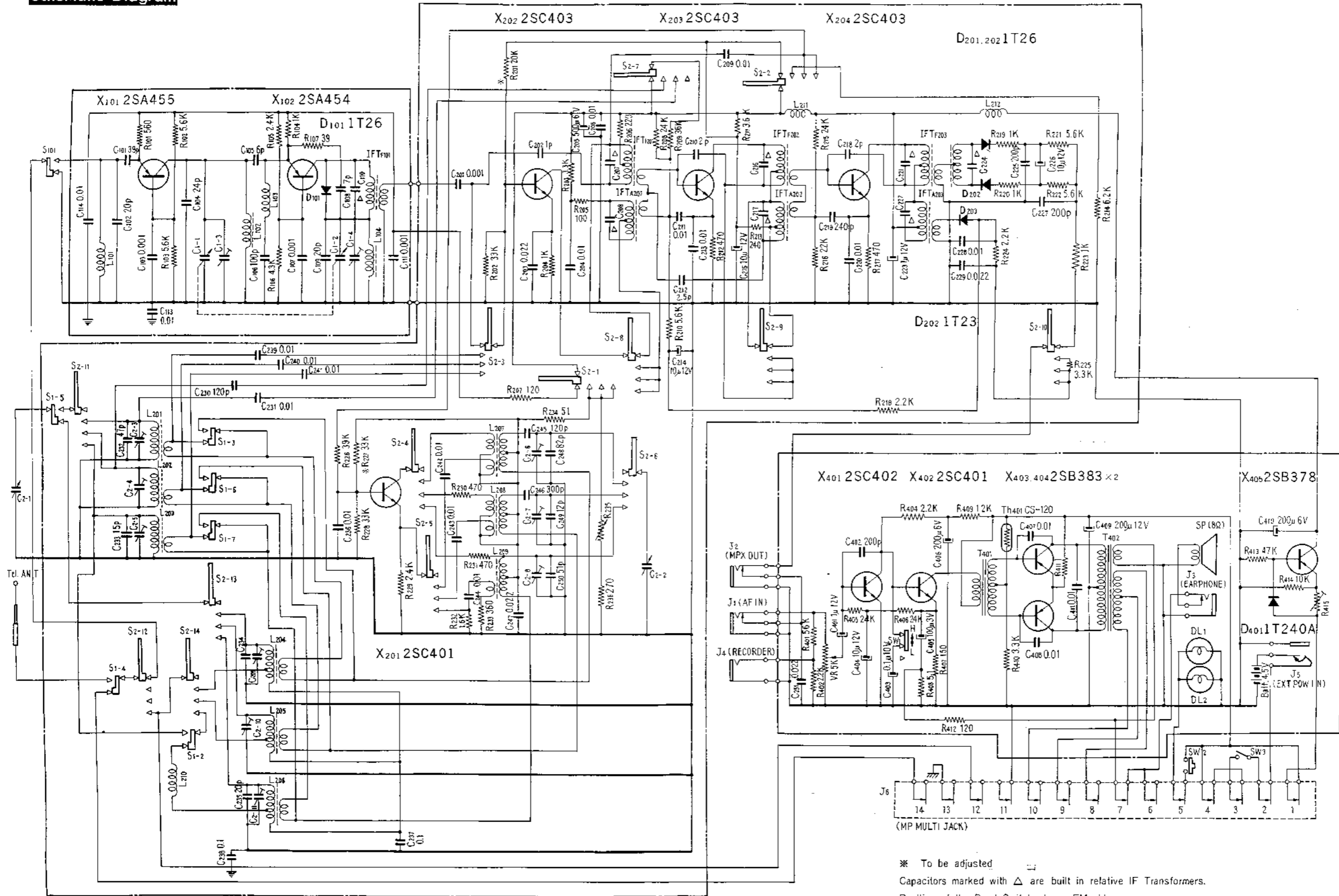

* To be adjusted
 Capacitors marked with Δ are built in relative IF Transformers.
 Position of the Band Switch shows FM side.

Mounting Diagram

FM Tuner Section

—Printed Side—

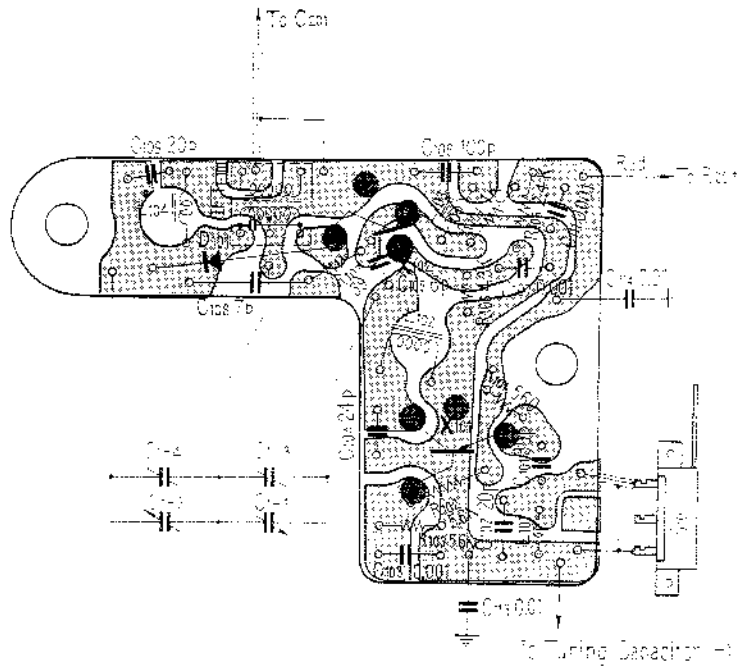

—Parts Side—

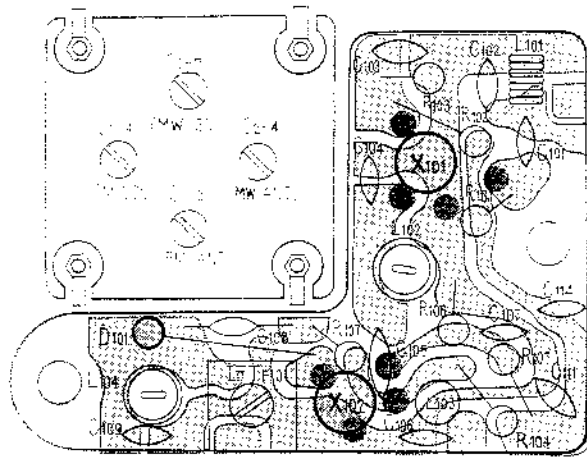

(Voltage and Current Distribution Chart at Zero Signal)

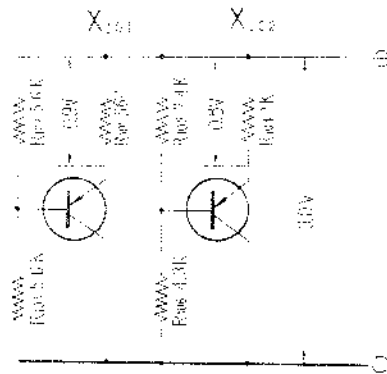

Mounting Diagram

AM Tuner - IF Section
—Printed Side—

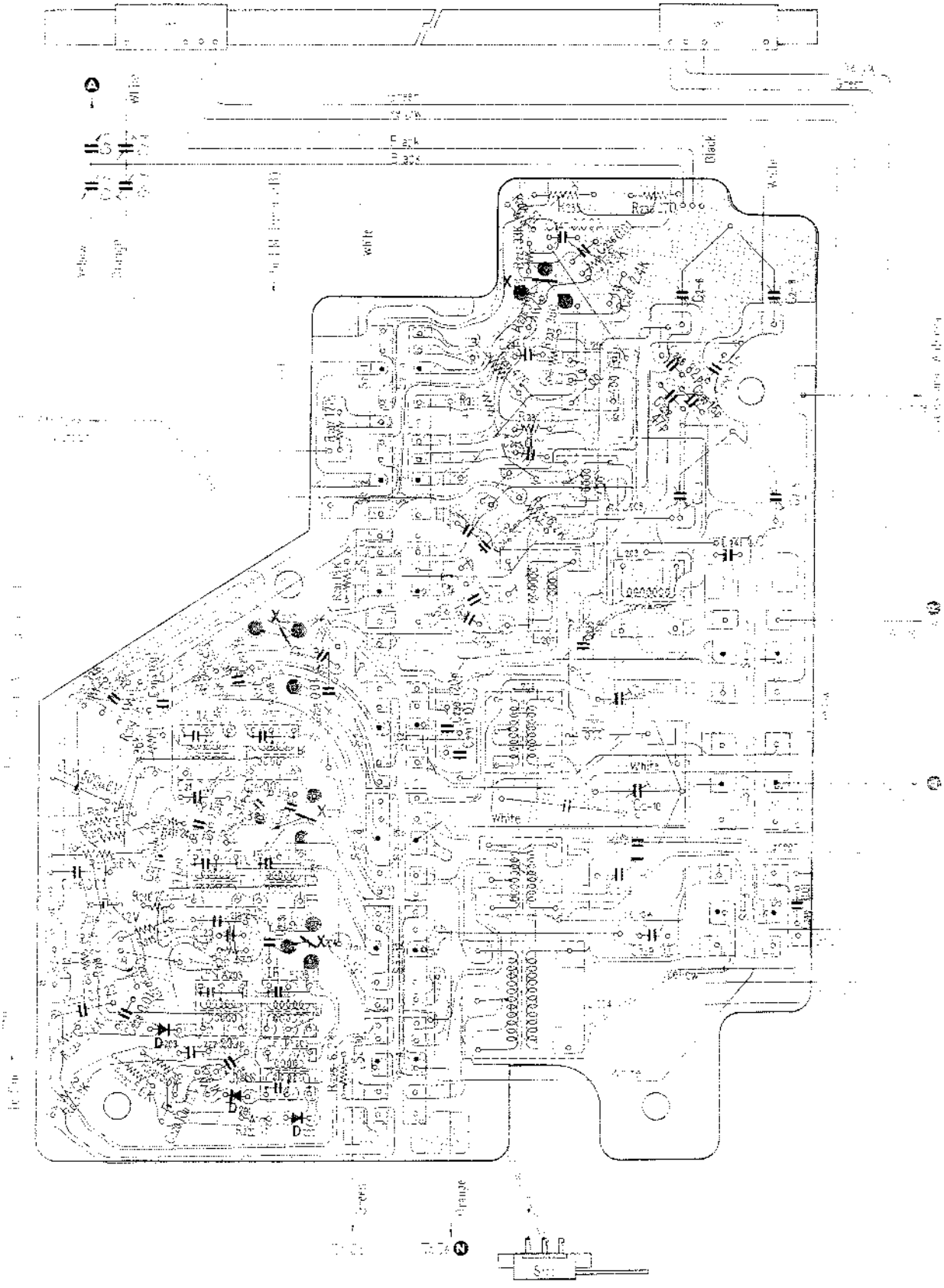

Yellow
Orange
White

100K
100K
100K

Black
White

Green
Orange



Mounting Diagram

AM Tuner - IF Section

--Parts Side--

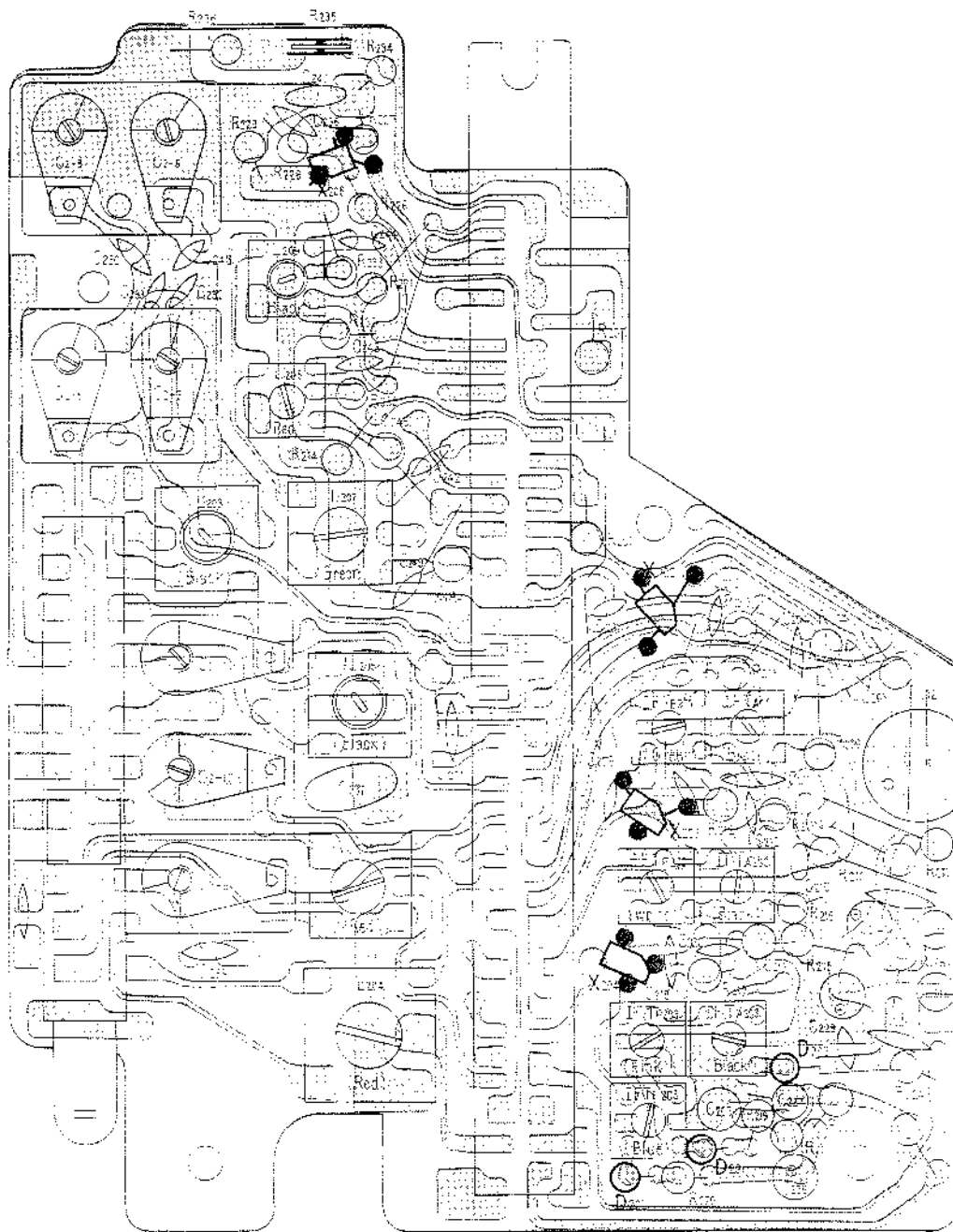

X201 X202 X203 X204

[Voltage and Current Distribution Chart at Zero Signal]

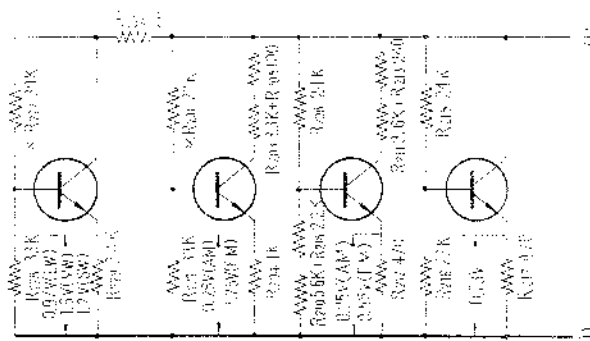

Mounting Diagram

AF Section

—Printed Side—

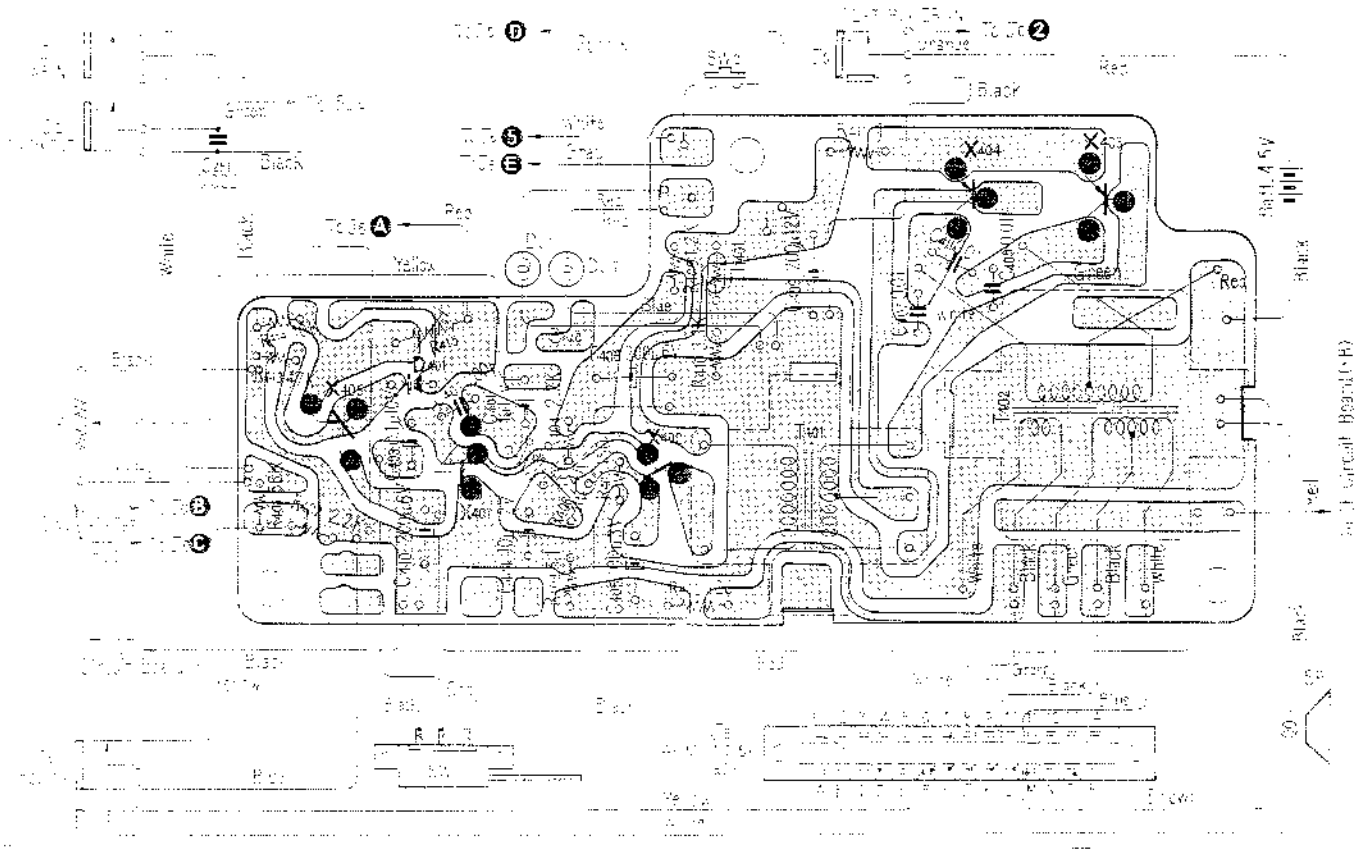

—Parts Side

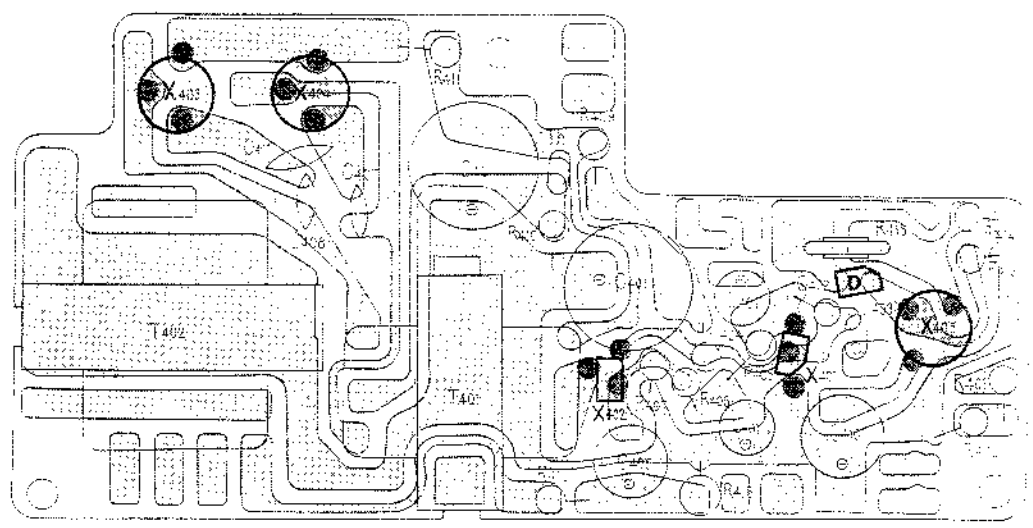

[Voltage and Current Distribution Chart at Zero Signal]

