



TYPE 1311-A

AUDIO OSCILLATOR

OPERATING INSTRUCTIONS

TYPE 1311-A

AUDIO OSCILLATOR

Form 1311-0100-B
June, 1963

Copyright 1963 by General Radio Company
West Concord, Massachusetts, USA

G E N E R A L R A D I O C O M P A N Y
WEST CONCORD, MASSACHUSETTS, USA

SPECIFICATIONS

FREQUENCY

Range: 11 fixed frequencies from 50 to 10,000 cps.

Control: 50, 60, 100, 120, 200, 400, 500, 1000, 2000, 5000, 10,000 cps selected by rotary switch. A vernier provides a $\pm 2\%$ adjustment about nominal.

Accuracy: $\pm 1\%$, vernier at 0.

OUTPUT

Power: 1w into matched load. (Taps provide at least 0.5w output into any resistive load between $80\text{m}\Omega$ and 8 k).

Voltage: Continuously adjustable from 0 to 1, 3, 10, 30, or 100, open circuit.

Current: Continuously adjustable from 0 to 40, 130, 400, 1300, 4000 ma, short circuit (approx).

Impedance: Between one and two times matched load, depending on control setting. Isolated from ground; hence, can be used to drive balanced circuits.

Stability (Typical after warmup): Amplitude, long term, better than 1%; short term, better than 0.01%. Frequency, long term, better than 0.1%.

DISTORTION AND NOISE LEVEL

Distortion: Less than 0.5% under any load condition. Typically less than 0.1% over most of range. Oscillator will drive short circuit without waveform clipping.

AC Hum: Typically less than 0.003% of output voltage.

GENERAL

Synchronization: A locking voltage from an external reference frequency can be introduced at a telephone jack. Locking range is approximately $\pm 3\%$ for 1-volt reference signal.

Terminals: Jack-top Type 938 Binding Posts with standard $\frac{3}{4}$ -inch spacing. Separate ground terminals holds Type 938-L Shorting Link which can be used to ground adjacent OUTPUT binding posts.

Power Input: 105 to 125 (or 210 to 250) v, 50 to 400 cps. Total power consumption varies between 7 and 22 watts, depending on load.

Mounting: Aluminum panel and cabinet, in grey-crackle finish, for rack or bench use.

Accessories Supplied: Type CAP-22 Power Cord, spare fuses.

Accessories Available: Type 480-P308 Adaptor Plate Set to permit mounting in standard 19-inch relay rack (Panel height $5\frac{1}{4}$ inches).

Dimensions: Width 8, height 6, depth $7\frac{3}{4}$ inches (205 by 155 by 200 mm) over-all.

Net Weight: 6 pounds (2.8 kg).

U.S. Patent No. 2,751,549

For a more complete description, see *GENERAL RADIO EXPERIMENTER*, 36, 8 and 9, August-September, 1962.

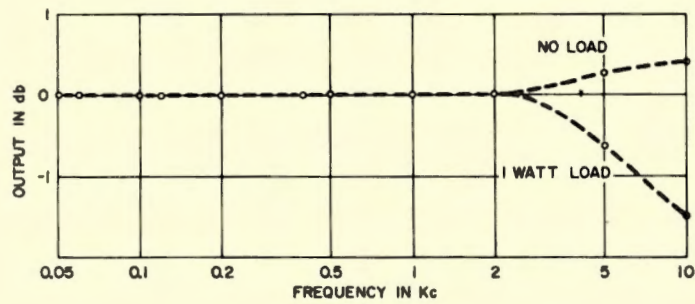

Figure A. Output of Type 1311-A as a function of frequency, loaded and unloaded (typical).

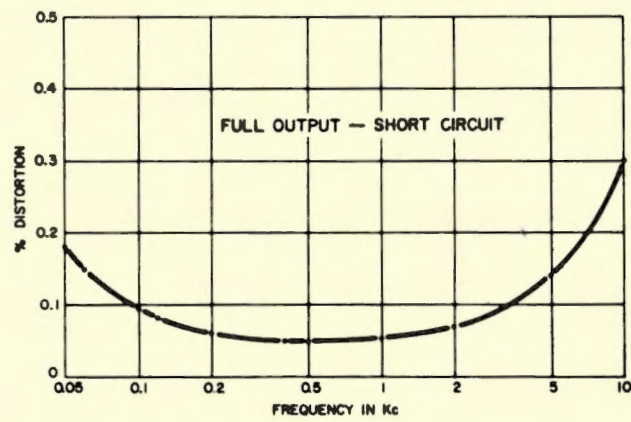
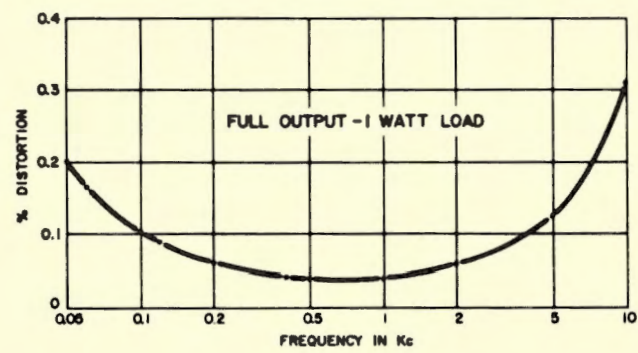
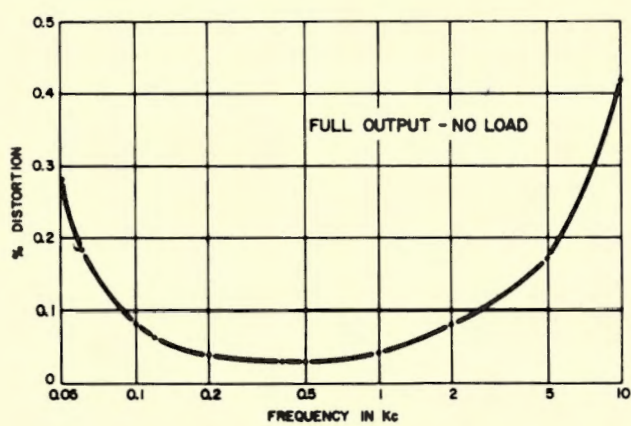
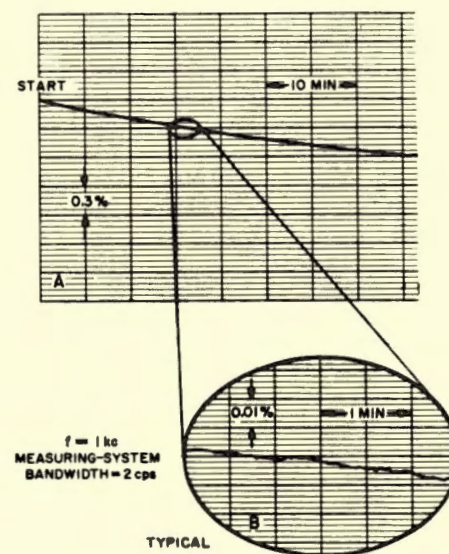

Figure B. Distortion characteristics of Type 1311-A as functions of frequency and load (typical).

Figure C. Typical output amplitude stability of the oscillator, showing warmup drift (A) and short-term variation (B).



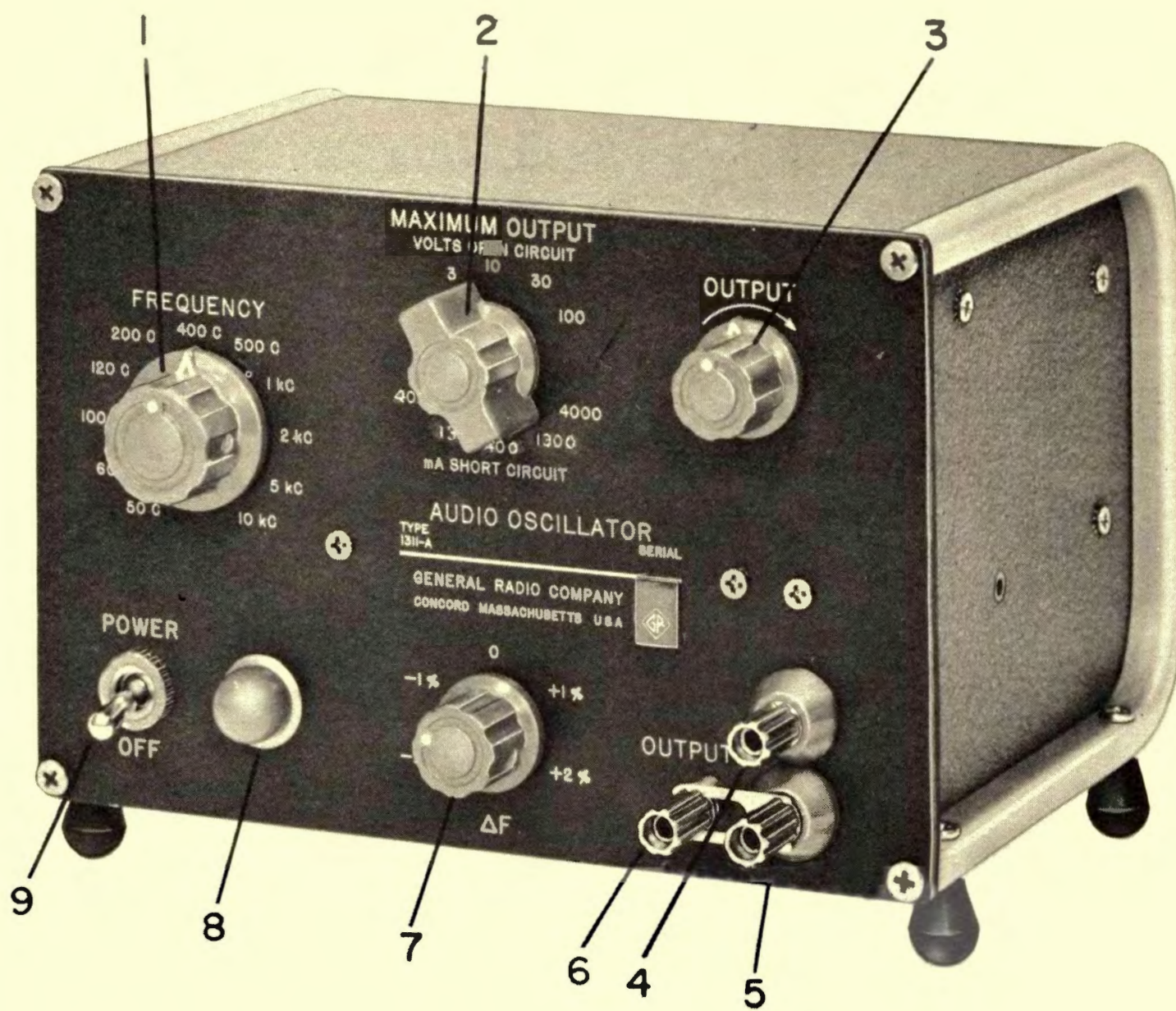

Figure 1-1. Type 1311-A Audio Oscillator.

TABLE OF CONTENTS

Section 1: INTRODUCTION	1	Section 4: PRINCIPLES OF OPERATION	9
1.1 Purpose	1	4.1 General	9
1.2 Description	1	4.2 Circuit Description	9
Section 2: INSTALLATION	3	Section 5: SERVICE AND MAINTENANCE	12
2.1 General	3	5.1 Warranty	12
2.2 Rack Mounting	3	5.2 Service	12
2.3 Power Input	3	5.3 Minimum Performance Standards	12
2.4 Output Frequency Change	5	5.4 Input Power	12
2.5 Environmental Consideration	5	5.5 Removal of Cover	14
Section 3: OPERATING PROCEDURE	6	5.6 Trouble Analysis	14
3.1 Preparation for Use	6	5.7 Removal and Replacement	15
3.2 Operating Procedure	6	5.8 Internal Adjustments	16
		5.9 AC Power Conversion	16

SECTION 1

INTRODUCTION

1.1 PURPOSE.

The Type 1311-A Audio Oscillator (Figure 1-1) is a complete, compact, and self-contained audio-frequency source intended for general laboratory use, and is particularly well suited for use in audio-frequency bridge measurements. It can provide an essentially pure sinusoidal output, stable in amplitude and frequency, over a wide range of load impedances, at 11 frequencies. Provision has been made for a 12th frequency, which the user can readily add by the installation of two commonly available precision resistors.

1.2 DESCRIPTION.

1.2.1 GENERAL. The Type 1311-A is a transistorized RC Oscillator, which makes extensive use of negative feedback to attain amplitude and frequency stability of a high order, as well as long-term reliability. The output system uses a multitap shielded transformer capable of matching impedances from 0.25 to 2500 ohms. It is well isolated from the oscillator circuitry to provide a distortion-free waveform to any impedance, including a short circuit.

The instrument is ac powered and uses a regulated solid-state power-supply circuit to provide stable dc to all stages over a wide range of power demands. Operation at ac inputs of 115 or 230 volts can be achieved by selection of appropriate taps on the input winding of the primary power transformer.

The Type 1311-A is designed for bench use but can conveniently and inexpensively be altered for rack mounting by the addition of the General Radio Type 480-P308 Adaptor Plate Set.



TYPE 1311-A AUDIO OSCILLATOR

1.2.2 CONTROLS. Front panel controls are listed and described in Table 1-1.

**TABLE 1-1
CONTROLS AND INDICATORS**

Ref (Fig. 1-1)	Ref Desig	Name	Type	Function
1	S101	FREQUENCY	12-position rotary switch	Selects output frequency.
2	S102	MAXIMUM OUTPUT	5-position rotary switch	Selects output transformer tap.
3	R139	OUTPUT	Linear potentiometer	Adjusts output level.
7	R138	ΔF	Linear potentiometer	Adjusts output frequency $\pm 2\%$ about nominal.
9	S501	POWER	Toggle switch	Turns instrument on or off.
8	P501	None	Light	Glowes when primary power on.

1.2.3 CONNECTORS. Connectors provided on the Type 1311-A are listed and described in Table 1-2.

**TABLE 1-2
CONNECTORS**

Ref (Fig. 1-1)	Ref Desig	Name	Type	Function
4-6	J101 thru J103	OUTPUT	Jack-top binding posts (GR Type 938)	Output terminals and ground.
	PL501	None	3-prong plug (GR Type 109-A)	Power input terminal.
	J104	None	Telephone	External Sync input

SECTION 2

INSTALLATION

2.1 GENERAL.

The Type 1311-A Audio Oscillator, as supplied, is intended for independent bench use. However, it may be adapted to rack mounting, either independently or in combination with a similarly sized instrument, such as the General Radio Type 1232-A Tuned Amplifier and Null Detector, with which it is commonly associated for use with ac bridges.

2.2 RACK MOUNTING.

2.2.1 INDEPENDENT A Type 480-P308 Adaptor Plate Set is available to adapt the instrument to a standard relay rack. The kit consists of a pair of plates which attach to the front panel by means of a $\frac{1}{2}$ -inch machine screw in each corner. The U-shaped aluminum end frames, into which the screws thread, must be left in place. If the rubber mounting feet on the end frames present a clearance problem, they should be removed.

2.2.2 COMBINATION. To combine the Type 1311-A in a standard relay-rack mounting configuration with the Type 1232-A Tuned Amplifier and Null Detector, the Type 480-P316 Adaptor Plate Set should be used. This set consists of a pair of adaptor plates which attach to the outside edges of the front panels of the instruments and an adaptor strip which joins the instruments (see Figure 2-1). The $\frac{1}{2}$ -inch mounting screws in the corners of the instrument are used to attach the adaptors. The end frames should be left in place, but the rubber mounting feet may be removed.

2.2.3 TYPE 1620-A PRECISION CAPACITANCE MEASURING ASSEMBLY. The Type 1311-A is an integral part of the Type 1620-A Precision Capacitance Measuring Assembly (see Figure 2-1). As such, it is mounted in combination with the Type 1232-A Tuned Amplifier and Null Detector, as described in paragraph 2.2.2. To the combined assembly is added a pair of large-sized end frames (part No. ZFRI-308-2R). The complete assembly is then stack-mounted on top of a Type 1615-AM Capacitance Bridge and the large end frames fastened together by machine screws.

2.3 POWER INPUT.

2.3.1 NORMAL OPERATION. The Type CAP-22 Three-Wire Power Cord supplied should be attached to PL501 on the rear panel and plugged into



TYPE 1311-A AUDIO OSCILLATOR

a standard grounding-type power receptacle providing 105-125 volts at 50 to 400 cps.

COMBINATION RACK MOUNTING

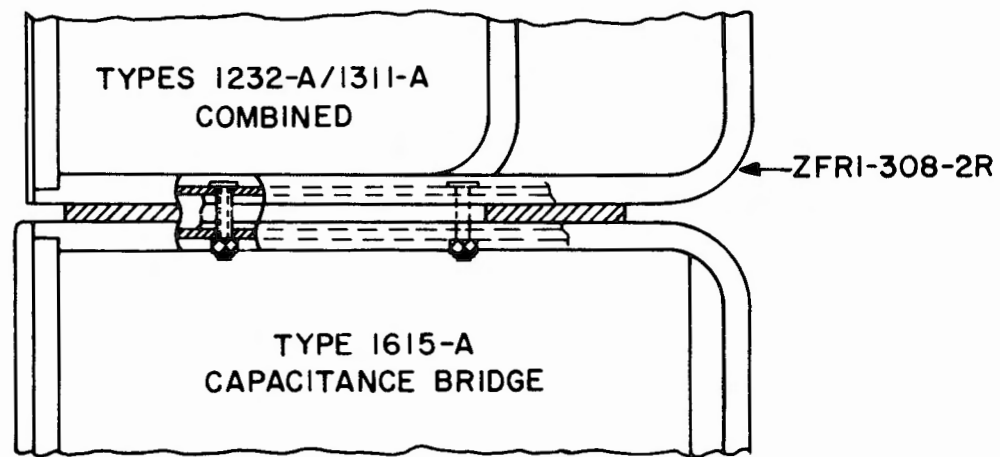
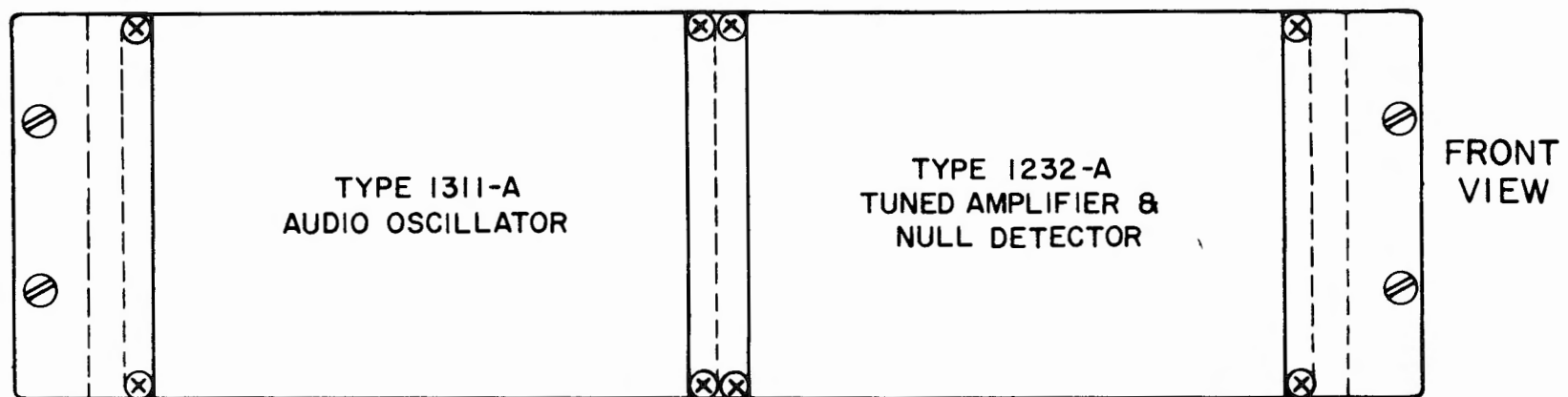
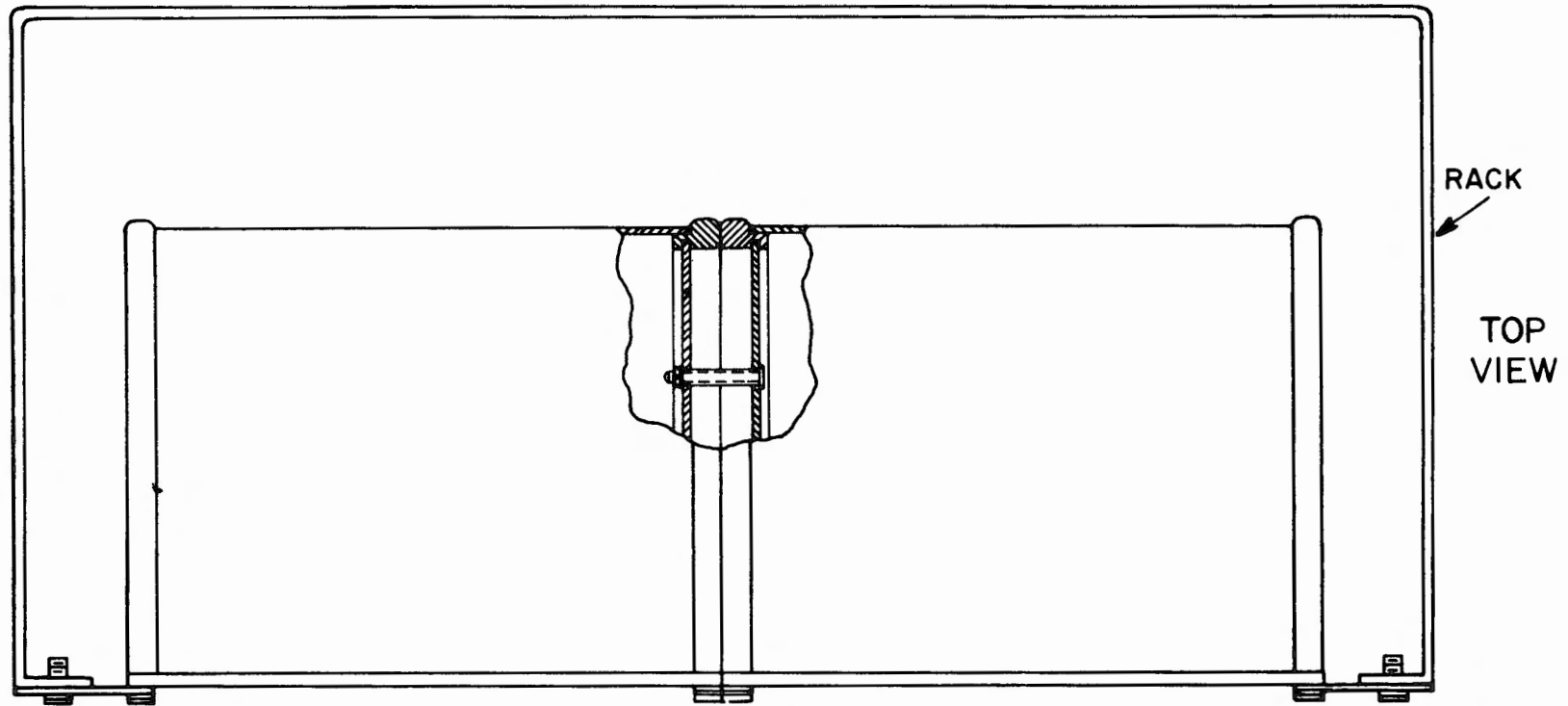

Figure 2-1. Mounting options.

2.3.2 HIGHER VOLTAGE. The instrument may be operated at ac inputs from 210 to 250 volts, provided that minor wiring and fuse changes described in Section 5 have been performed.

2.4 OUTPUT FREQUENCY CHANGE.

To add a 12th audio output frequency, or to change any of the existing fixed frequencies, resistor pairs in the Wien-bridge circuit may be installed, or replaced, as described in Section 5.

2.5 ENVIRONMENTAL CONSIDERATIONS.

2.5.1 TEMPERATURE. The Type 1311-A will operate within specifications over an ambient temperature range of 0 to 50 C. It is not affected by humidity.

2.5.2 EXTERNAL FIELDS. Since the Type 1311-A is often mounted with the sensitive Type 1232-A Null Detector, stray magnetic and electrostatic fields should be kept to a minimum by suitable shielding, and orientation of signal leads. A wire loop is included (internally) near the output terminals to cancel the magnetic field resulting from the $\frac{3}{4}$ -inch spacing of the output terminals, and will prevent magnetic pickup in the adjacent null detector, even at high current levels, if a General Radio Type 274-MB Shielded Output Cable is used. Alternatively, the Type 1311-A can be mounted at the right-hand side of the Type 1232-A, to place the output circuit as far as possible from the detector input terminals.



SECTION 3

OPERATING PROCEDURE

3.1 PREPARATION FOR USE.

3.1.1 POWER CONNECTIONS. Connect the Type 1311-A to a suitable source of power as indicated on the plate above the power receptacle on the rear panel. A three-wire power cord (Type CAP-22) is supplied.

3.1.2 GROUNDING. The instrument should normally be operated with the chassis grounded through the three-wire power cord. If the cord is not used, make the ground connection at J103(6, Figure 1-1) on the front panel, if required.

3.1.3 OUTPUT CONNECTION. Take the oscillator output from the jack-top binding post pair J101 - J102 (4 and 5, Figure 1-1). J101 is always used above ground, but J102 may be grounded or ungrounded, depending on the requirements of the test setup in use. A captive shorting-link affixed to J103 may be attached to J102, if it is desired to work one side of the output against ground. However, if ground loops pose a problem, disconnect the shorting link from J102 to achieve a completely isolated "floating" output.

3.1.4 OUTPUT-SHIELDING ACCESSORIES. In applications in which stray pickup is apt to be troublesome, use of a shielded patch cord is suggested. The General Radio Type 274-NL Patch Cord, a polarized 3-foot shielded cable with a shielded double plug at each end, is available for this purpose.

3.2 OPERATING PROCEDURE.

3.2.1 TURN-ON. Place the POWER switch (9, Figure 1-1) in up position; the lamp immediately to the right should glow.

NOTE

No extensive warm-up time is required; a few seconds is sufficient.

3.2.2 FREQUENCY SELECTION. Set the FREQUENCY switch (1, Figure 1-1) to the desired frequency. Use the ΔF control (7, Figure 1-1) to adjust the selected frequency over a range of approximately $\pm 2\%$ of nominal. The frequency of the output waveform is within $\pm 1\%$ of the panel

OPERATING PROCEDURE

engraving, with the ΔF control set at 0. For greater precision monitor the output with a frequency meter, such as the General Radio Type 1130-A Digital Frequency Meter.

3.2.3 POWER SELECTION. Set the MAXIMUM OUTPUT switch (2, Figure 1-1) to a value in volts or milliamperes (as engraved on the front panel) that is slightly greater than the amplitude of the voltage or current desired. Then, rotate the OUTPUT control (3, Figure 1-1) to make the fine adjustment. The OUTPUT control sets the output at zero in its fully counterclockwise position, and rotated to its fully clockwise position provides a continuous linear increase up to the value of the MAXIMUM OUTPUT control setting.

The maximum power output is approximately 1.1 watt, so that bridges with 1-watt ratio arms, such as most General Radio bridges, cannot be damaged by overload. At least 0.58 watt of signal power can be supplied to any load between 80 milliohms and 8 kilohms, with the appropriate setting of the output switch. See Figure 3-1 for a plot of these values.

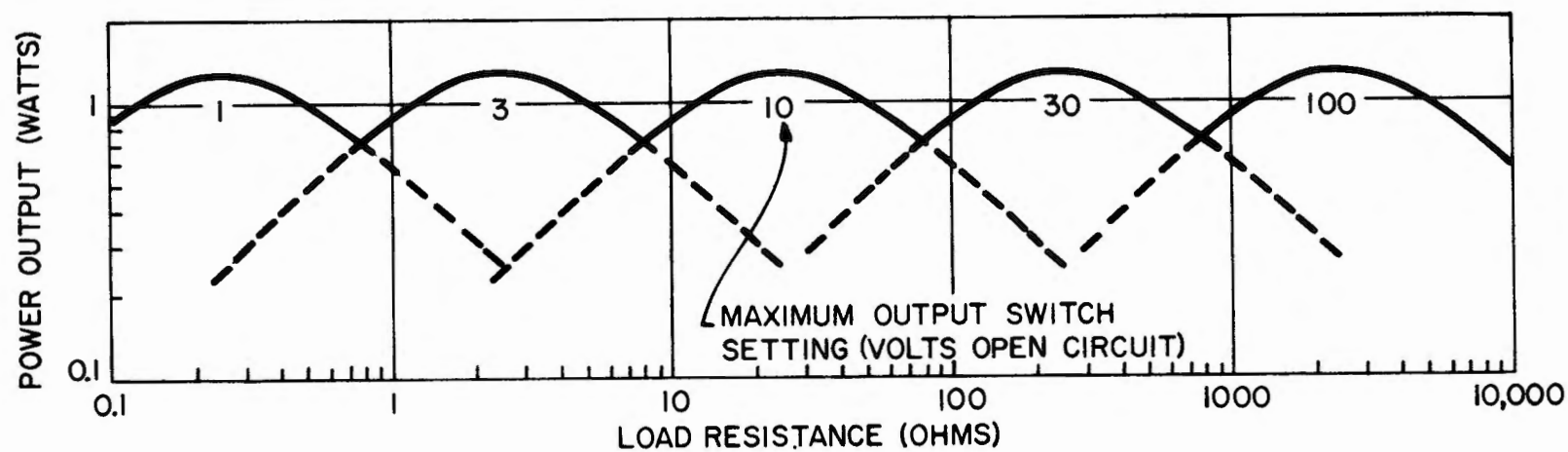

Figure 3-1. Typical power output as a function of load resistance.

3.2.4 IMPEDANCE MATCHING. Any setting of the output controls can be used with any load impedance without overloading the oscillator circuits. Even with a short circuit across the output terminals, the oscillator will still supply a sinusoidal current of the value indicated by the MAXIMUM OUTPUT control. This feature is particularly convenient when the oscillator is used as a source for ac bridge measurements, since it means that the output controls can be set to any position, and the waveform will not be distorted by mismatching.

The output winding is shielded from the oscillator circuits and may be used ungrounded, or grounded at a remote point. The latter procedure



TYPE 1311-A AUDIO OSCILLATOR

is recommended when the oscillator is used in bridge measurements, to eliminate circulating ground currents, which can cause errors.

The nominal source resistance is a function of the transformer tap selected by the MAXIMUM OUTPUT control setting and the position of the OUTPUT control. Figure 3-2 shows the relationship.

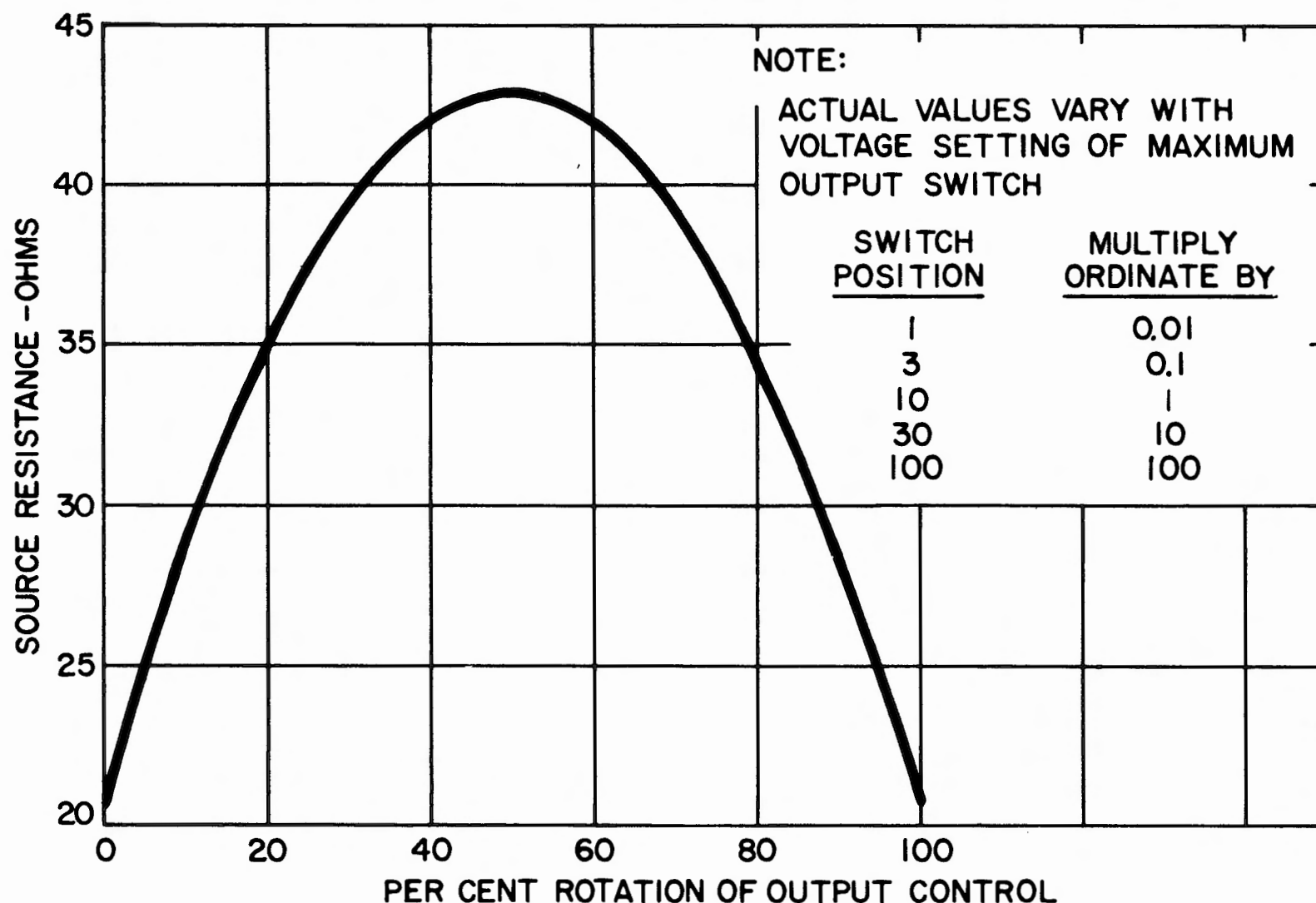

Figure 3-2. Source resistance as a function of output control settings.

3.2.5 FREQUENCY SYNCHRONIZATION. A telephone jack (J104) on the left side wall of the cabinet is provided to permit injection of an external standard frequency to control the output frequency of the Type 1311-A. This is particularly useful to drive the Type 1615-A Capacitance Bridge when making precise measurements of frequency-sensitive parameters such as dissipation factor. A 1-volt signal will result in a locking range of approximately $\pm 5\%$. For larger synchronizing signals, a resistor should be added in series with the signal lead. Use the following equation to calculate the value of the resistor required.

$$R \text{ (in kilohms)} \approx 5 (\text{Sync Volts} - 1)$$

The dc voltage on the reference signal should not exceed +50 volts. The General Radio Type 1120-A Frequency Standard can be used with the addition of this resistor.

SECTION 4

PRINCIPLES OF OPERATION

4.1 GENERAL.

The Type 1311-A Audio Oscillator uses a Wien-type network and a closed-loop, transistor-amplifier circuit to obtain a stable yet inexpensive signal source which will satisfy many oscillator requirements in the audio-frequency spectrum. See Figure 4-1 for a simplified diagram and Figure 5-2 for the complete schematic.

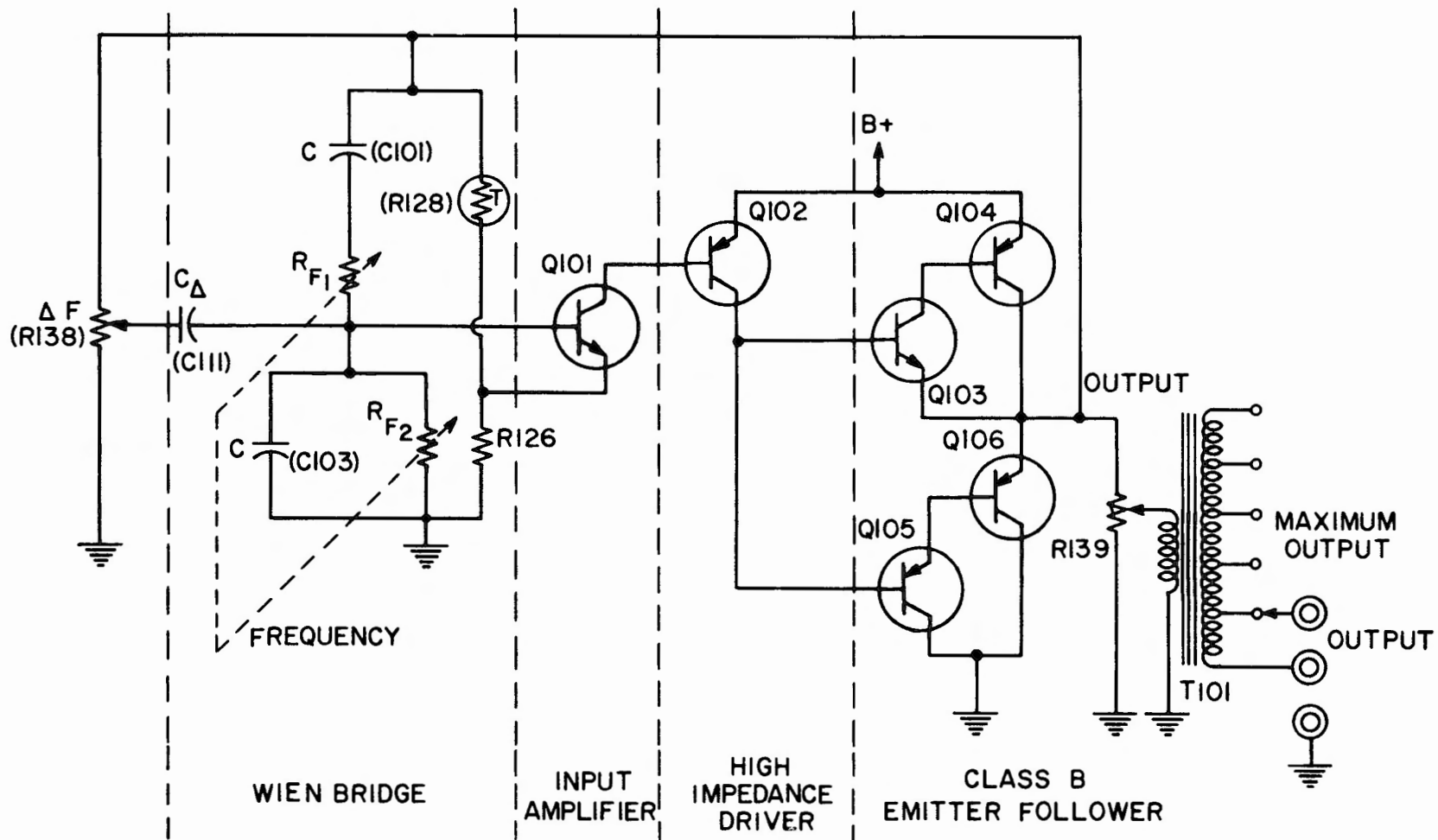

Figure 4-1. Simplified schematic diagram.

4.2 CIRCUIT DESCRIPTION.

4.2.1 FREQUENCY-DETERMINING NETWORK. The Wien-bridge circuit can be thought of as consisting of two parts: a frequency-determining network (C101, C103 and paired resistors R_{F1} , R_{F2}), which provides positive feedback to sustain oscillation, and a resistive divider (R128 and R126) which provides negative feedback to stabilize amplitude.*

* For a detailed discussion of this design feature, see Fulks, R. G., "Novel Feedback Loop Stabilizes Audio Oscillator," *ELECTRONICS*, Vol. 36 No. 5 February, 1963. Available as General Radio reprint A-107.



TYPE 1311-A AUDIO OSCILLATOR

The frequency-determining network has a transfer function:

$$\frac{e_{\text{OUT}}}{e_{\text{IN}}} = \frac{RCs}{1 + 3RCs + R^2C^2s^2}$$

$$\begin{aligned} \text{where } s &= j2\pi f \\ R &= R_{F1} = R_{F2} \\ C &= C101 = C103 \end{aligned}$$

At some oscillator frequency, f_0 , this function equals $+1/3$. The frequency is determined by any of 11 pairs of precision metal-film resistors, R_{F1} , R_{F2} , selected by the FREQUENCY switch. With this circuit, frequency can be adjusted over a 200-to-1 range simply by changes in resistors. The frequency vernier adjustment, ΔF , is potentiometer R138, which controls the signal voltage on C_{Δ} (C111), one of the capacitors in the network.

The resistive divider is used to set the gain of the associated amplifier chain to $+3$. The net loop gain is then $+1$ and the circuit oscillates at the frequency f_0 .

A small bead thermistor, R128, automatically adjusts its resistance to the value needed to maintain oscillations. Its time constant is short enough to provide rapid correction for amplitude variations, yet long enough to cause little distortion at the lower frequencies. It operates at a high temperature, in an evacuated bulb, to minimize the effects of ambient temperature. This thermistor, used with the high-stability, low-noise amplifier described below, results in an oscillator with amplitude (modulation) noise typically less than 0.01% rms.

4.2.2 AMPLIFIER. The amplifier uses six transistors in a single, direct-coupled feedback loop. The input circuit is chosen for low-noise performance. Transistor Q102 provides a high-impedance drive for the class-B output stage, and achieves a minimum of crossover distortion, yet does not require complicated, temperature-sensitive biasing networks. Negative feedback is used to obtain a transfer characteristic which is substantially independent of transistor characteristics, resulting in excellent stability, low distortion, and long-term reliability. Components R132, C107, and C108 comprise a phase-compensation network used to maintain high-frequency stability in view of the large amount of negative feedback involved.

The input impedance of the amplifier is approximately 10 megohms. The output impedance is approximately 0.005 ohm, so that changes in load have very little effect on the oscillator.

4.2.3 OUTPUT TRANSFORMER. The winding resistance of the output transformer, T101, isolates the oscillator from the load and ensures that the output waveform will not be clipped under any load condition. The output winding is tapped to provide five switch-selectable, output-voltage ranges to match a wide variety of load requirements. The output winding is doubly shielded from the oscillator circuits for isolation, when the output is used off ground (floating). A simplified schematic diagram of the output circuit is shown in Figure 4-2.

The second shield is used to minimize possible current flow through the distributed capacitance, C_{FL} (≈ 500 pf), thence through an external circuit ground. The resulting floating potential, E_{FL} , of the output winding is less than 0.25 volt.

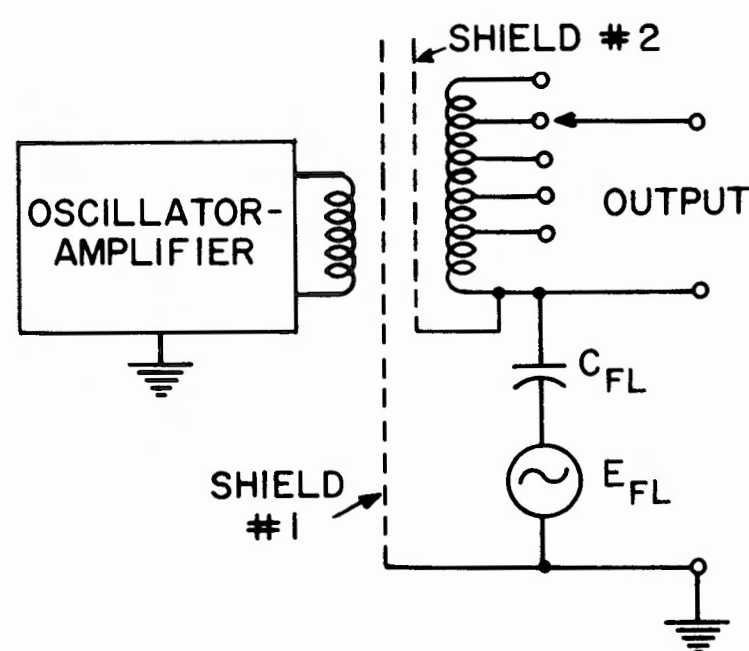

Figure 4-2. Simplified schematic diagram of output circuit.

4.2.4 POWER SUPPLY. Power transformer, T501, is used to apply 25.5 v ac to a silicon-diode bridge-rectifier and filter circuit. The filtered dc output passes through a simple regulator circuit, made up of Q501, Q502, and CR505, a zener diode. The supply provides a low-impedance, ripple-free, 20-v dc source to power the oscillator circuitry. The hum level of the oscillator output is typically 90 db below rated output signal value.

4.2.5 SYNCHRONIZATION. The oscillator can be locked to an external reference frequency by insertion of a signal from the reference source into the oscillator loop. In this application, a blocking capacitor (C112) and an isolating resistor (R140) are used to couple the reference source to the emitter of Q101.



SECTION 5

SERVICE AND MAINTENANCE

5.1 WARRANTY.

We warrant that each new instrument sold by us is free from defects in material and workmanship and that properly used it will perform in full accordance with applicable specifications for a period of two years after original shipment. Any instrument or component that is found within the two-year period not to meet these standards after examination by our factory, district office, or authorized repair-agency personnel will be repaired, or, at our option, replaced without charge, except for tubes or batteries that have given normal service.

5.2 SERVICE.

The two-year warranty stated above attests the quality of materials and workmanship in our products. When difficulties do occur, our service engineers will assist in any way possible. If the difficulty cannot be eliminated by use of the following service instructions, please write or phone our Service Department (see rear cover), giving full information of the trouble, and of steps taken to remedy it. Be sure to mention the serial and type numbers of the instrument.

Before returning an instrument to General Radio for service, please write to our Service Department or nearest district office, requesting a Returned Material Tag. Use of this tag will ensure proper handling and identification. For instruments not covered by the warranty, a purchase order should be forwarded to avoid unnecessary delay.

5.3 MINIMUM PERFORMANCE STANDARDS.

The Type 1311-A in normal operation should perform within the standards described in Table 5-1. Table 5-2 lists the test equipment required to check minimum performance. If the instrument does not meet minimum performance standards, refer to paragraph 5.6 for trouble analysis procedures.

5.4 INPUT POWER.

The input power at 115/230 volts, 60 cps normally should not exceed 7 watts no load and 22 watts with the terminals short-circuited and the OUTPUT control fully clockwise.

TABLE 5-1
MINIMUM PERFORMANCE STANDARDS FOR TYPE 1311-A

TEST	FRE- QUENCY SWITCH POSITION	MAXIMUM OUTPUT SWITCH POSITION	OUTPUT CONTROL POSITION	Δ F POSITION	LOAD	NORMAL INDICATION	IF INDICATION ABNORMAL
Frequency Accuracy	All	10 v	cw stop	0	None	Using frequency counter or meter, check that the frequency is within $\pm 1\%$ of nominal value.	Refer to para 5.6.
Δ f Control	1 kc	10 v	cw stop	-2%, 0, +2%	None	Using frequency counter or meter, check that frequency change is approximately plus and minus 2%.	Refer to para 5.6.
Output Voltage	1 kc	All	cw stop	0	None	Using VTVM, check that output voltage is greater than that indicated by MAXIMUM OUTPUT Control.	Adjust by means of R129 (para 5.8.1).
Output Voltage	All	10 v	cw stop	0	None	Using VTVM, check that output voltage is greater than 10 volts.	Adjust by means of R129 (para 5.8.1).
OUTPUT Control	1 kc	10 v		0	None	Using VTVM, check that output voltage can be adjusted by OUTPUT Control from 0 to 10 v.	Refer to para 5.6.
Output Power	1 kc	10 v	cw stop	0	Power Output Meter	Using Power Output Meter, check that output power is greater than 1.0 watt into some impedance near 25Ω .	Adjust by means of R129 (para 5.8.1).
Output Distor- tion	50 c, 1 kc, 10 kc	10 v	cw stop	0	(None) (25Ω) (1Ω)	Using Distortion Meter, check that distortion is less than 0.5%.	Refer to para 5.6.
Synchro- nization	1 kc	10 v	cw stop	0	None	Apply 1-v, 1-kc signal to J104. With oscilloscope at OUTPUT, vary ext.-oscillator freq. Type 1311-A should remain locked over a 5% range (approx)	Refer to para 5.6.



**TABLE 5-2
TEST EQUIPMENT REQUIRED**

Description	Recommended GR Type Numbers*
Frequency Counter or Meter	1130-A, 1150-A, 1142-A
Vacuum Tube Voltmeter	1800-A, 1806-A
Distortion and Noise Meter or Wave Analyzer	1932-A, or 1900-A
Output-Power Meter	1840-A
Variable-Frequency Audio Oscillator	1300-A, 1302-A, 1304-B
Oscilloscope	Laboratory quality, min bandwidth 1 kc, min vert sensitivity 5 v/cm
Multimeter	Sensitivity 20,000 ohms/v

*Or equivalent

5.5 REMOVAL OF COVER.

To remove the cover, loosen the two captive thumb screws on the rear of the case and pull straight back.

5.6 TROUBLE ANALYSIS.

Perform the following procedures to isolate defects causing instrument malfunction as indicated by paragraphs 5.3 and 5.4. See Figures 5-1 through 5-5 for circuit function and part location.

- a. Disconnect primary power and remove cover.
- b. Check fuses F501 and F502; replace if defective.
- c. Visually check detail parts inside instrument for obvious defects, such as broken leads or charred surfaces. Repair or replace, as necessary.
- d. Reapply primary power and, with multimeter, check for 25 v ac across anchor terminals AT501 and AT502.

CAUTION

Semiconductor elements can be damaged by transients resulting from the insertion of instrument probes. Always turn off the power before connecting any test equipment to other than the output terminals. Restore power when connection is made.

- e. Switch multimeter to dc scale and check voltages as indicated on Figure 5-2. For accessibility of test points on etched-circuit board, see Figure 5-5.

NOTE

Complete circuit is enclosed in a single dc feedback loop, so that failure of one component will probably cause all voltages to differ considerably from the values shown.

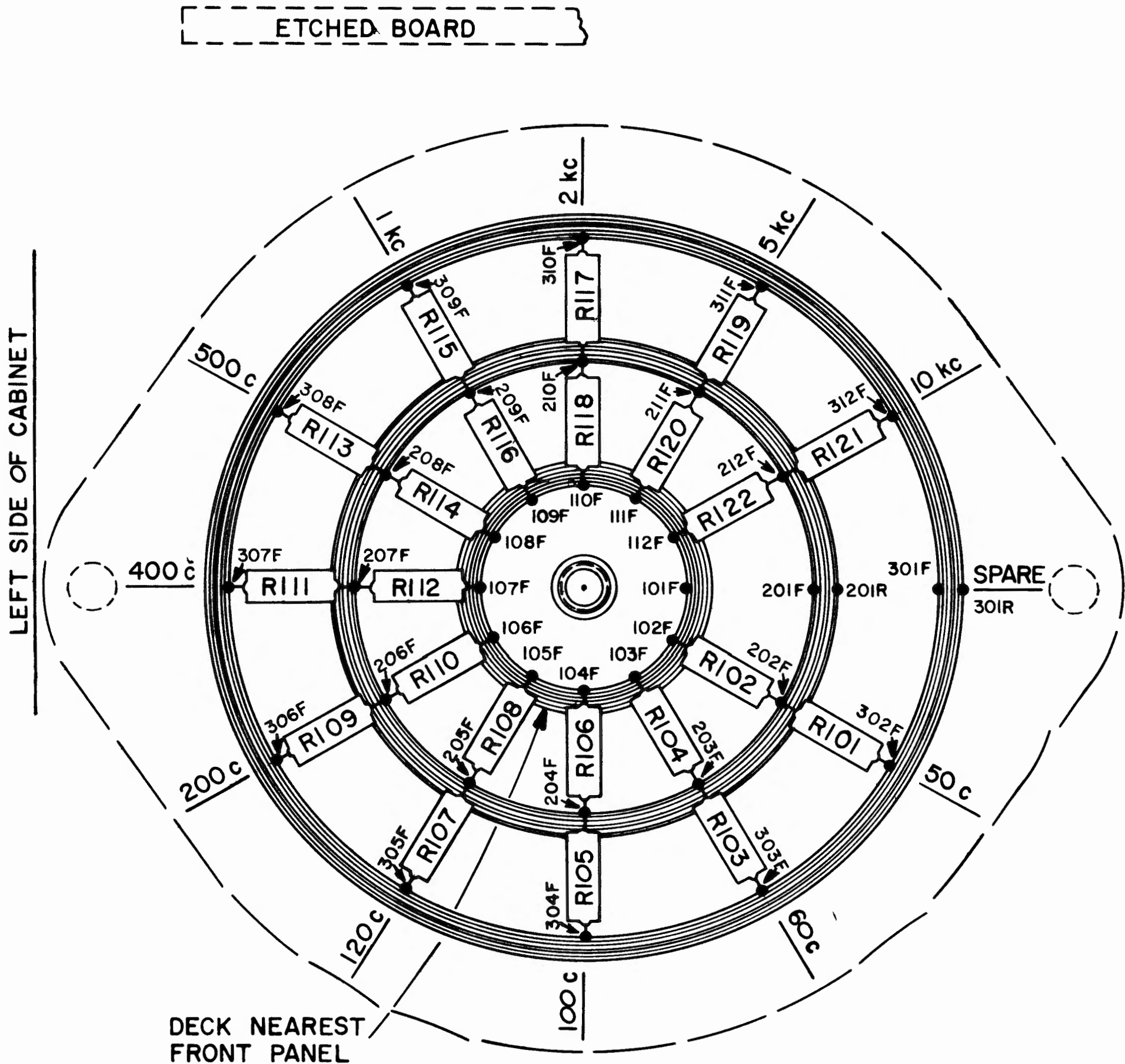

Figure 5-1. Wiring diagram for FREQUENCY switch S101.

5.7 REMOVAL AND REPLACEMENT.

5.7.1 GENERAL. Faulty parts should be removed and replaced by units meeting the description given in the Parts List at the end of this section.

5.7.2 SEMICONDUCTORS. Since the expected life of the semiconductor elements in the Type 1311-A is comparable to that of other components, they are soldered into the circuit boards. As a general rule, it is much safer to determine the faulty semiconductors from over-all circuit test, rather than to remove them individually for testing.



CAUTION

Transistors are easily damaged by excessive heat; exercise care when unsoldering them.

5.7.3 PILOT LIGHT. The pilot light (P501) is operated well below its rated voltage. If a change is required, unscrew the red cap from the front of the panel and replace the light with a Mazda # 44.

5.8 INTERNAL ADJUSTMENTS. (See Figures 5-2 through 5-5.)

5.8.1 OSCILLATOR LEVEL. R129, a secondary control used to adjust oscillator power level, is a screw-driver-adjustable potentiometer mounted on the underside of the etched circuit at its inside edge. With the dust cover removed, it is accessible from the bottom of the instrument.

R129 should be set so that the no-load output voltage, as indicated by a VTVM across the OUTPUT terminals, is approximately 5% higher than the value indicated by the MAXIMUM OUTPUT switch, when the OUTPUT control is turned fully clockwise.

5.8.2 OSCILLATOR FREQUENCY. Any frequency between 50 cycles and 10 kc can be added to those provided, by the installation of two precision resistors, R_F , whose values can be determined from the following relation:

$$R_F = 1.61 \times 10^3 \frac{(1 \text{ kc})}{(f_{\text{kc}})}$$

To utilize the twelfth position of the FREQUENCY selector switch, first calculate the value of the resistors required. For example, if a 600-cps output is wanted, then

$$R_F = 1.61 \times 10^3 \frac{(1000)}{(0.6)} = 2.66 \text{ kilohms.}$$

The resistors must be mounted on the FREQUENCY switch (S101). An unused position (between the 50-c and 10-kc positions) is provided for this purpose. Before installing the resistors on S101, remove the jumper between contacts 101F and 201F. The contacts 101F, 201F, and 301F may be reached from the bottom of the instrument. See Figure 5-1 for switch details.

5.9 AC POWER CONVERSION.

5.9.1 GENERAL. The Type 1311-A is available from the factory wired either for use with inputs of 105 to 125 or 210 to 250, 50 to 400 cps. However, if the user wishes to convert the instrument from one power option to the other, it is necessary merely to change wiring to the power-transformer input winding from power switch S501 and replace fuses.

SERVICE AND MAINTENANCE

WARNING

Pull the power cord from the receptacle before performing the following procedures.

5.9.2 TRANSFORMER WIRING. Remove the dust cover and place the instrument upside down on the bench. The input transformer (T501) is mounted on the side wall.

For 115-volt operation, transformer leads 1 and 3 should connect to lug 5 on S501 and leads 2 and 4 to lug 6 on S501. For 230-volt operation, lead 1 connects to lug 5, lead 4 to lug 6, and leads 2 and 3 are joined at anchor terminal AT506.

5.9.3 FUSES. Two fuses (F501 and F502), mounted on the inside of the vertical panel at the top rear, protect the instrument from electrical overload. They are accessible from the bottom, also. For 115 v, use 0.25-amp fuses; and for 230 v, use 0.125-amp fuses.

PARTS LIST

REF NO.	DESCRIPTION	PART NO.
R101	RESISTOR, Film, 32.1k $\pm 1\%$ 1/2w	6450-2321
R102	RESISTOR, Film, 32.1k $\pm 1\%$ 1/2w	6450-2321
R103	RESISTOR, Film, 26.8k $\pm 1\%$ 1/2w	6450-2268
R104	RESISTOR, Film, 26.8k $\pm 1\%$ 1/2w	6450-2268
R105	RESISTOR, Film, 16.1k $\pm 1\%$ 1/2w	6450-2161
R106	RESISTOR, Film, 16.1k $\pm 1\%$ 1/2w	6450-2161
R107	RESISTOR, Film, 13.4k $\pm 1\%$ 1/2w	6450-2134
R108	RESISTOR, Film, 13.4k $\pm 1\%$ 1/2w	6450-2134
R109	RESISTOR, Film, 8.03k $\pm 1\%$ 1/2w	6450-1803
R110	RESISTOR, Film, 8.03k $\pm 1\%$ 1/2w	6450-1803
R111	RESISTOR, Film, 4.01k $\pm 1\%$ 1/2w	6450-1401
R112	RESISTOR, Film, 4.01k $\pm 1\%$ 1/2w	6450-1401
R113	RESISTOR, Film, 3.21k $\pm 1\%$ 1/2w	6450-1321
R114	RESISTOR, Film, 3.21k $\pm 1\%$ 1/2w	6450-1321
R115	RESISTOR, Film, 1.61k $\pm 1\%$ 1/2w	6450-1161
R116	RESISTOR, Film, 1.61k $\pm 1\%$ 1/2w	6450-1161
R117	RESISTOR, Film, 803 $\pm 1\%$ 1/2w	6450-0803
R118	RESISTOR, Film, 803 $\pm 1\%$ 1/2w	6450-0803
R119	RESISTOR, Film, 321 $\pm 1\%$ 1/2w	6450-0321
R120	RESISTOR, Film, 321 $\pm 1\%$ 1/2w	6450-0321
R121	RESISTOR, Film, 161 $\pm 1\%$ 1/2w	6450-0161
R122	RESISTOR, Film, 161 $\pm 1\%$ 1/2w	6450-0161
R123	RESISTOR, Composition, 11k $\pm 5\%$ 1/2w	6100-3115
R124	RESISTOR, Composition, 10k $\pm 5\%$ 1/2w	6100-3105
R125	RESISTOR, Composition, 33k $\pm 5\%$ 1/2w	6100-3335
R126	RESISTOR, Composition, 220 $\pm 5\%$ 1/2w	6100-1225
R127	RESISTOR, Composition, 150 $\pm 5\%$ 1/2w	6100-1155
R128	RESISTOR, Thermistor, 30k $\pm 25\%$	6740-1402

PARTS LIST (continued)

REF NO.	DESCRIPTION	PART NO.
R129	POTENTIOMETER, Carbon, 250 \pm 20%	6040-0200
R130	RESISTOR, Composition, 10k \pm 5% 1/2w	6100-3105
R131	RESISTOR, Composition, 6.8k \pm 5% 1/2w	6100-2685
R132	RESISTOR, Composition, 10 \pm 5% 1/2w	6100-0105
R133	RESISTOR, Composition, 680 \pm 5% 1/2w	6100-1685
R134	RESISTOR, Composition, 47 \pm 5% 1/2w	6100-0475
R135	RESISTOR, Composition, 1k \pm 5% 1/2w	6100-2105
R136	RESISTOR, Composition, 2.2k \pm 5% 1/2w	6100-2225
R137	RESISTOR, Composition, 47 \pm 5% 1/2w	6100-0475
R138	POTENTIOMETER, Carbon, 250 \pm 10%	6000-0100
R139	POTENTIOMETER, Wire-wound, 20 \pm 5%	0971-3905
R140	RESISTOR, Composition, 4.7k \pm 5% 1/2w	6100-2475
R501	RESISTOR, Wire-wound, 6.8 \pm 10% 1/2w	6760-9689
R502	RESISTOR, Composition, 47 \pm 5% 1/2w	6100-0475
R503	RESISTOR, Composition, 2.2k \pm 5% 1/2w	6100-2225
C101	CAPACITOR, Plastic, 0.1 μ f \pm 1% 100dcwv	4860-8249
C102	CAPACITOR, Electrolytic, 100 μ f 15dcwv	4450-2800
C103	CAPACITOR, Plastic, 0.1 μ f \pm 1% 100dcwv	4860-8249
C104	CAPACITOR, Ceramic, 0.0022 μ f \pm 20% 500dcwv	4405-2229
C105A	CAPACITOR, } Electrolytic, 1500 μ f 15dcwv	4450-0700
C105B,C		
C107	CAPACITOR, Ceramic, 680pf \pm 20% 500dcwv	4404-1689
C108	CAPACITOR, Ceramic, 0.022 μ f +80 -20% 50dcwv	4407-3229
C109	CAPACITOR, Electrolytic, 100 μ f 15dcwv	4450-2800
C110	CAPACITOR, Electrolytic, 100 μ f 15dcwv	4450-2800
C111	CAPACITOR, Mica, 3300pf \pm 10%	4570-1333
C112	CAPACITOR, Electrolytic, 5 μ f +100 -10% 50dcwv	4406-2339
C501	CAPACITOR, Ceramic, 0.0033 μ f \pm 20% 500dcwv	4406-2339
C502	CAPACITOR, Ceramic, 0.0033 μ f \pm 20% 500dcwv	4450-4000
C503A	CAPACITOR, 400 μ f 50dcwv	
C503B	CAPACITOR, Electrolytic, 200 μ f 50dcwv	4450-3900
C503C	CAPACITOR, 200 μ f 50dcwv	
CR501 thru CR504	DIODE, 1N3253	6081-1001
CR505	DIODE, 1N968A	6083-1017
F501	FUSE, Slow-blow, 0.125 amp (230v)	} Type 3AG 5330-0450
F502	FUSE, Slow-blow, 0.125 amp (230v)	
F501	FUSE, Slow-blow, 0.25 amp (115v)	
F502	FUSE, Slow-blow, 0.25 amp (115v)	
J101	JACK, Binding Post	4060-0400
J102	JACK, Binding Post	4060-0410
J103	JACK, Binding Post	4060-1800
J104	JACK, Phone	4260-1260
PL501	PLUG, Power	4240-0600
P501	PILOT LIGHT, (Mazda #44)	5600-0700
S101	SWITCH, Wafer	7890-3100
S102	SWITCH, Wafer	7890-3110
S501	SWITCH, Toggle	7910-1300
T101	TRANSFORMER, Output	0745-4250
T501	TRANSFORMER, Power	0745-4240
Q101	TRANSISTOR, 2N1304	8210-1304
Q102	TRANSISTOR, 2N1305	8210-1305
Q103	TRANSISTOR, 2N1304	8210-1304
Q104	TRANSISTOR, 2N176	8210-1760
Q105	TRANSISTOR, 2N1305	8210-1305
Q106	TRANSISTOR, 2N176	8210-1760
Q501	TRANSISTOR, 2N176	8210-1760
Q502	TRANSISTOR, 2N1304	8210-1304

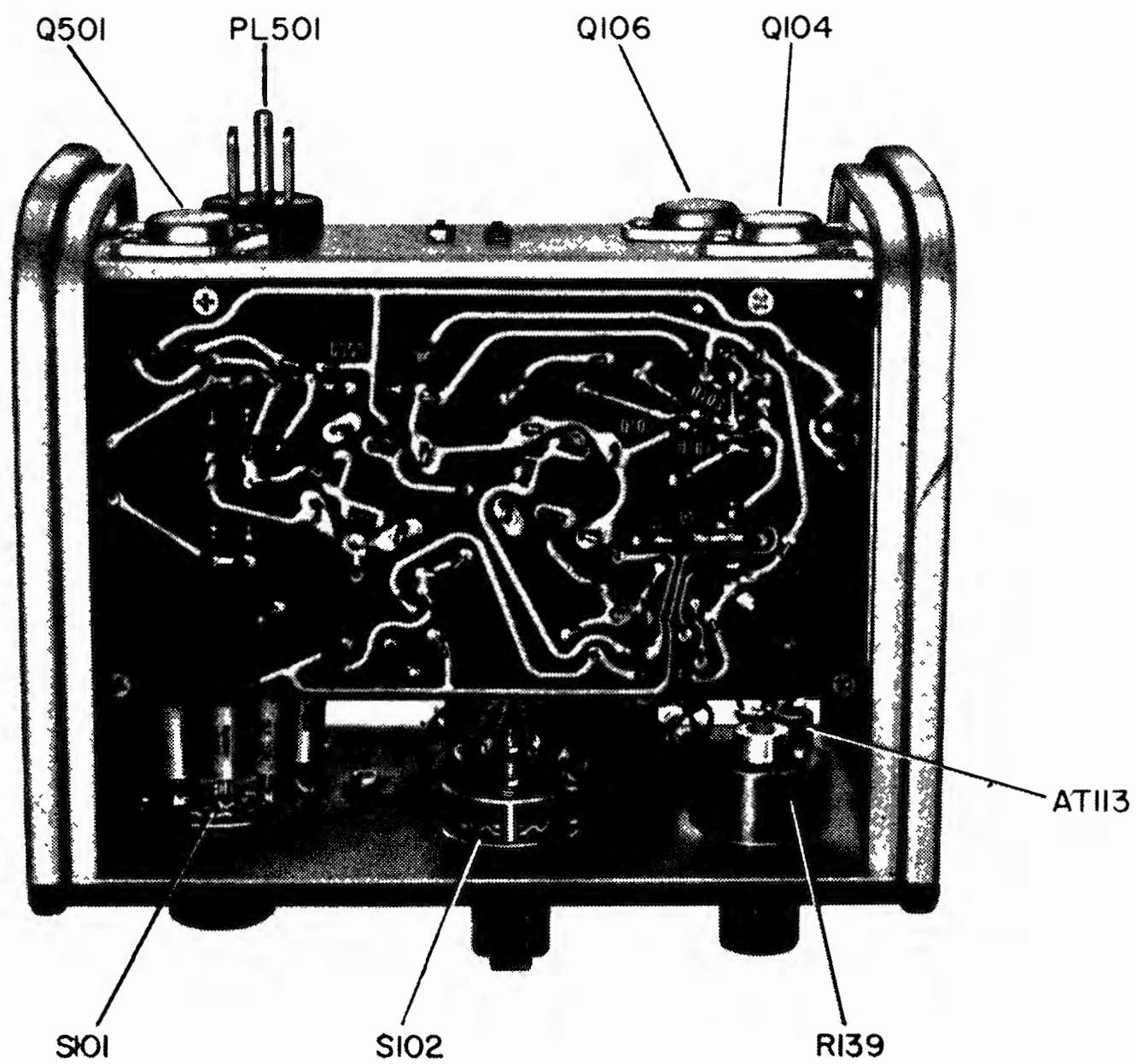

Figure 5-3. Top rear interior view.

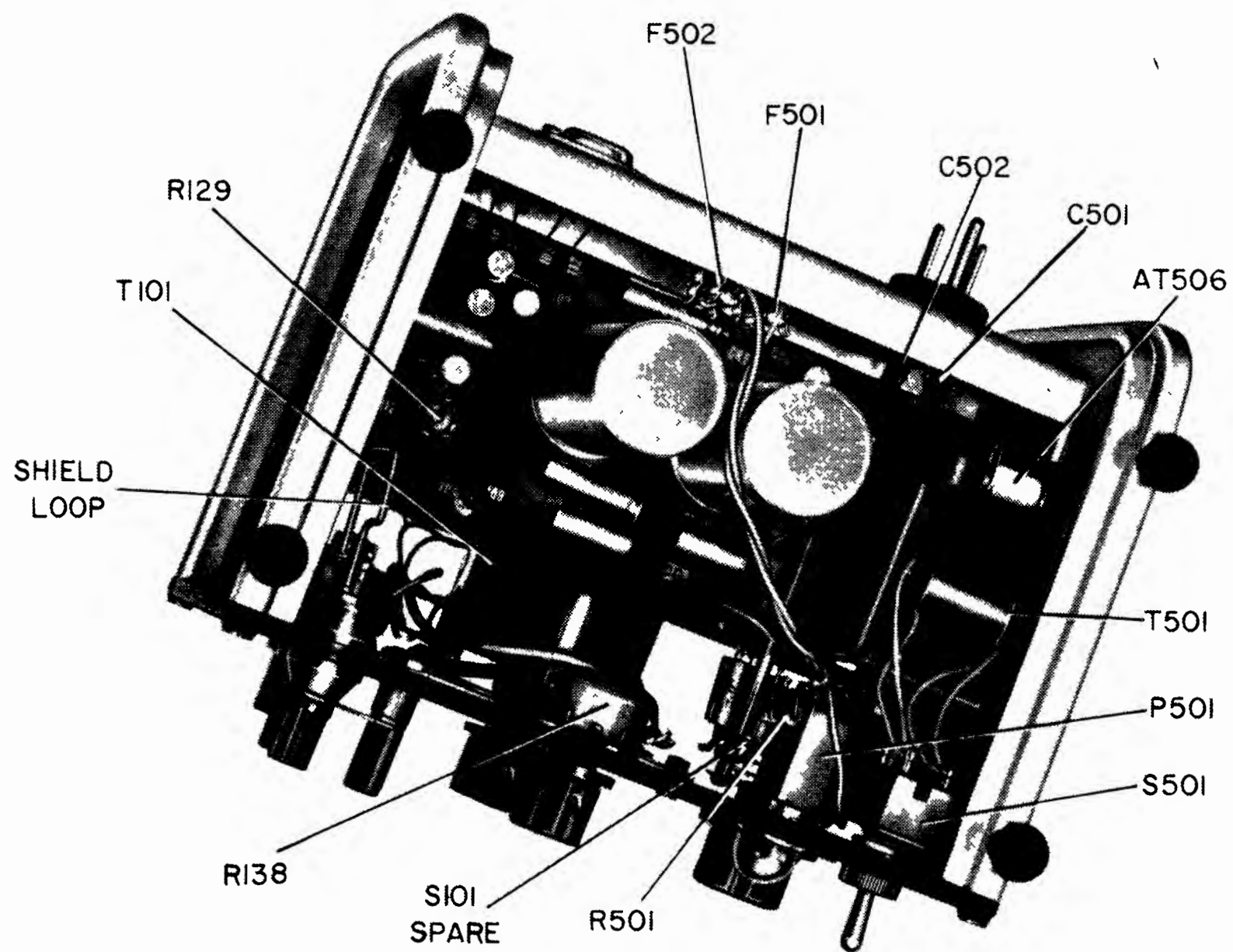

Figure 5-4. Bottom rear interior view.



Figure 5-5. Etched circuit board.

GENERAL RADIO COMPANY

WEST CONCORD, MASSACHUSETTS*

EMerson 9-4400

Mission 6-7400

SALES ENGINEERING OFFICES

NEW YORK*

Broad Avenue at Linden
Ridgefield, New Jersey
Telephone N.Y. WOrth 4-2722
N.J. WHitney 3-3140

SYRACUSE

Pickard Building
East Molloy Road
Syracuse 11, New York
Telephone GLenview 4-9323

PHILADELPHIA

1150 York Road
Abington, Pennsylvania
Telephone TURner 7-8486
Phila., HANcock 4-7419

WASHINGTON*

Rockville Pike at Wall Lane
Rockville, Maryland
Telephone 946-1600

CHICAGO*

6605 West North Avenue
Oak Park, Illinois
Telephone Village 8-9400

* Repair services are available
at these district offices.

LOS ANGELES*

1000 North Seward Street
Los Angeles 38, California
Telephone HOLlywood 9-6201

SAN FRANCISCO

1186 Los Altos Avenue
Los Altos, California
Telephone WHitecliff 8-8233

DALLAS

2501-A West Mockingbird Lane
Dallas 35, Texas
Telephone FLEetwood 7-4031

FLORIDA

113 East Colonial Drive
Orlando, Florida
Telephone GARden 5-4671

CANADA*

99 Floral Parkway
Toronto 15, Ontario
Telephone CHerry 6-2171

* Repair services are available
at these district offices.

General Radio Company (Overseas), Zurich, Switzerland
Representatives in Principal Overseas Countries