

TC-540

General Export Model

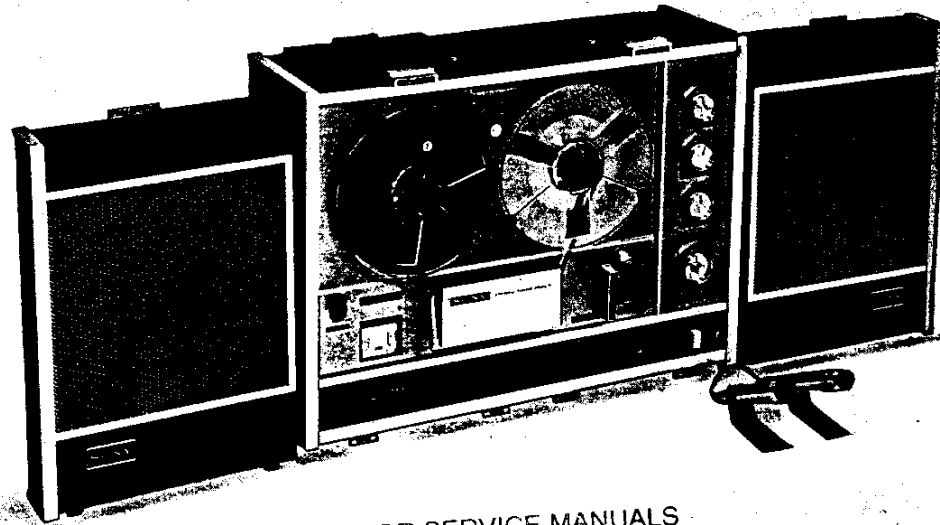

FOR SERVICE MANUALS
CONTACT:
MAURITRON TECHNICAL SERVICES
www.mauritron.co.uk
TEL: 01844 - 351694
FAX: 01844 - 352654
Specifications

Power Requirements: AC 50/60 Hz, 100, 110, 117, 125, 220, & 240 V, 65W

Reel Size: 7 inches or smaller

Tape Speeds: 7½ ips, 3¾ ips, 1⅞ ips (19 cm/s), 9.5 cm/s, 4.8 cm/s)

Frequency Response: 30~20,000 Hz at 7½ ips (19 cm/s)
30~13,000 Hz at 3¾ ips (9.5 cm/s)
30~10,000 Hz at 1⅞ ips (4.8 cm/s)

Flutter and Wow: Less than 0.09% at 7½ ips (19 cm/s)
Less than 0.12% at 3¾ ips (9.5 cm/s)
Less than 0.16% at 1⅞ ips (4.8 cm/s)

Signal-to-Noise Ratio: Better than 50 dB

Harmonic Distortion: Less than 2% at normal recording level

Recording Time: 4-Track stereophonic
1 hr 30 min at 7½ ips (19 cm/s)
3 hrs at 3¾ ips (9.5 cm/s)
6 hrs at 1⅞ ips (4.8 cm/s)

4-Track monophonic
3 hrs at 7½ ips (19 cm/s)
6 hrs at 3¾ ips (9.5 cm/s)
12 hrs at 1⅞ ips (4.8 cm/s)

Inputs: Microphone Inputs (2)
Impedance, 600Ω

Maximum Sensitivity, -73 dBs (0.19 mV)
Auxiliary Inputs (2)
Impedance, 100kΩ

Maximum Sensitivity, -20 dBs (0.078 V)
Rec./P.B. Connector (1)
Impedance 10kΩ

Outputs: Line Outputs (2)
Impedance 100kΩ

Output Level 0 dBs (0.775 V)
External Speaker Outputs (2)
Impedance 8Ω

Output Level 11.2 dBs (2.83 V)
Headphone Outputs (2)
Impedance 8 kΩ

Output Level 11.2 dBs (2.83 V)
Rec./P.B. Connector (1)
Impedance 10 kΩ

Power Output: 5 watts Max. per channel

Music power 20 watts with both channels
Speakers: 4×8" (10×20 cm); Cabinet speaker... (2)
4" (10 cm); Lid speaker (2)

Transistors: 24 pcs

Diodes: 8 pcs

Dimensions: 19⅝" (W) × 9⅞" (H) × 15⅞" (D)
(500 × 252 × 391 mm)

Weight: 41 lbs. 10 oz. (19 kg)

SONY®

SERVICE MANUAL

Table of Contents

	Page
Specifications	1
General Description	2
Technical Features	2~4
Block Diagram	4
Cabinet Top View	5
Cabinet Back View	6
Chassis Bottom View	6
Chassis Top View	7
Method of Disassembling the Set	8
Removal of Mounted Circuit Boards	9~10
Modification to Different Household Frequency	10
Mechanical Adjustment	11~14
Electrical Adjustment	15~17
Level Diagram	18
Functions of Mechanism	19~20
Wiring Diagram	21~23
Mounting Diagram	
Noise Suppress Switch Board Section (Conductor Side)	24
Noise Suppress Switch Board Section (Component Side)	24
Schematic Diagram	24~26
Mounting Diagram	
Pre-Amplifier Board Section (Conductor Side)	27~28
Pre-Amplifier Board Section (Component Side)	29~30
Power Amplifier Board Section (Conductor Side)	31
Power Amplifier Board Section (Component Side)	32
Power Supply & Bias OSC Board Section (Conductor Side)	33
Power Supply & Bias OSC Board Section (Component Side)	34
Speaker Circuit Board Section (Conductor Side)	35
Speaker Circuit Board Section (Component Side)	35
SOUND-ON-SOUND Board Section (Conductor Side)	36
SOUND-ON-SOUND Board Section (Component Side)	36
Exploded Diagram	37~42

General Description

Model TC-540 is a high-quality, solid state tape recorder designed with the up-to-date engineering techniques of SONY. Its mechanical advantages include the capability of being used in either horizontal or vertical position, 3-speed selector, retractable pinch roller, lids which can be put on even if 7-inch reels are mounted on the turntables, and scrape filter which prevents FM noise. The electrical advantages of this machine are found in 4-speaker system, through-speaker-monitoring system, bass-treble separate tone control, automatic shut-off switch and noise suppressor switch. In addition, Model TC-540 is internally provided with 2-head sound-on-sound circuit which is used for sound-on-sound recording from the left channel to the right channel, and vice versa.

Technical Features**1. SPEAKER SYSTEM**

The speaker system of the TC-540 tape recorder consists of cabinet speakers, 4"×8" (10 cm×20 cm), serving as woofers, and lid speakers, 4"×4" (10 cm×10 cm), serving as tweeters. The lid speakers are provided with 3-m cords. When the lid speakers are not used, the cabinet speakers are capable of covering the entire audio frequency band in reproduction.

FOR SERVICE MANUALS
 CONTACT:
MAURITRON TECHNICAL SERVICES
 www.mauritron.co.uk
 TEL: 01844 - 351694
 FAX: 01844 - 352554

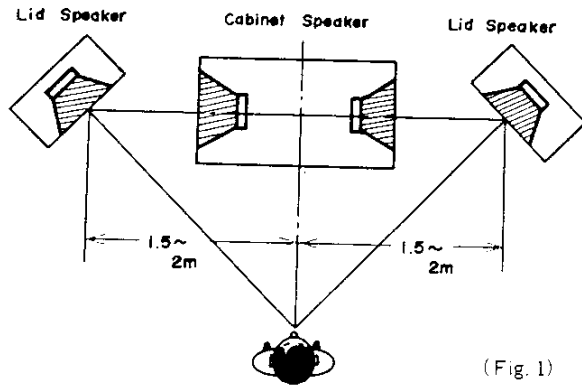

(Fig. 1)

The typical speaker arrangement of TC-540 is as shown in Fig. 1. The cabinet speakers having no directivity contribute much to quality reproduction in the low frequency range. The cross-over frequency of the speakers is 300 Hz to 400 Hz. Introduced hereunder are other two methods of speaker arrangement available for the stereo tape recorder. Reference can be made to these methods to understand how advanced the present TC-540 speaker arrangement is,

METHOD 1 Two lids, each provided with one speaker, are used. The cabinet speakers are not used. In this method, a lid for a woofer must have a larger speaker box. The present lid, however, is limited in speaker box size and, hence, poor-quality reproduction will result in the low frequency range.

METHOD 2 Two speakers are used, one being installed to the lid and the other to the cabinet. The lid and cabinet, however, differ from each other in speaker box size, resulting in difference in tone quality.

In the TC-540 speaker arrangement, every possible deficiency is corrected. The advantage that small-size lid speakers may be used offers compact and lightweight design of the machine.

2. SCRAPE FILTER

Generally, the tape vibrates longitudinally with its natural frequency when it is transported. Vibration frequency (cps) bears a close relation to the modulus of longitudinal elasticity, specific gravity and span of the tape. Such a vibration is negligible when no signal is recorded. However, if any high-frequency signal is recorded, it is modulated to bring about sidebands similar to tape noise on both sides of the signal frequency. These sidebands are heard as FM noise (something like hiss noise) having a certain level when listening to them carefully. They can be discriminated from tape noise because they are changed in volume when the record signal frequency is shifted.

It has often been reported that an input signal whose frequency is higher than 5 kHz cannot be reproduced with clear sound when it is recorded. This complaint seems to have directed against FM noise due to these sidebands. The scrape filter (roller) is located between the erase head and the record/playback head as shown in Fig. 2. In operation, it decreases the span of the tape and increases vibration frequency 3 or 4 times. When this frequency is increased beyond the audible range, the node of vibration of the tape is brought close to the record/playback head to prevent vibration of the tape. Under such a condition, the sidebands are eliminated and, in turn, FM noise is reduced over nearly entire frequency range as shown in Fig. 3.

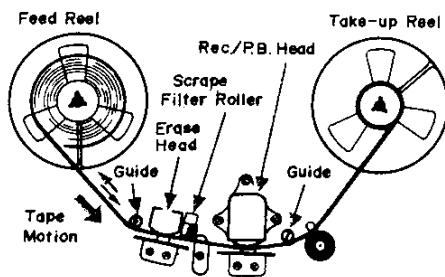

(Fig. 2)

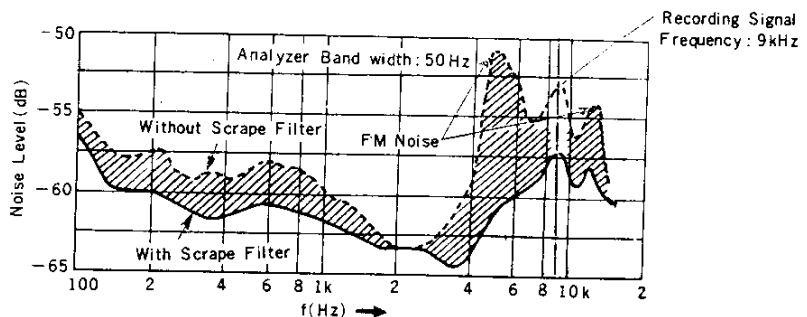

Noise Level when recording 9 kHz signal. (Fig. 3)

3. POWER AMPLIFIER

The power amplifier of Model TC-540 is designed by modifying the ordinary SEPP OTL circuit (shown in Fig. 4 & 5) and successfully adding Darlington circuits (shown in Fig. 5) thereto. The function of Darlington circuit is as follows:

The details of Darlington circuit are shown in Fig. 6. In this circuit, two NPN type transistors (Q_2 and Q_4) are connected in series with each other. The collector current (emitter current) of Q_2 becomes the base current of Q_4 . The base current (I_{B1}) of Q_2 is amplified at h_{fe1} (the forward-current transfer ratio of Q_2), and flows to Q_4 , where it becomes the base current (I_{B2}). This current is again amplified at h_{fe2} (the forward-current transfer ratio of Q_4). The overall forward current transfer ratio (h_{fe}) is written as $h_{fe} = h_{fe1} \times h_{fe2}$.

Hence, Darlington circuit is in one sense a transistor in which Q_2 and Q_4 are combined to increase h_{fe} to a great extent (Fig. 7). Darlington circuit shown in Fig. 5 provides the same function. Darlington circuit (1) amplifies the positive half and Darlington circuit (2) the negative half of the cycle, thereby supplying a greatly amplified output to the load (speaker). It can rightly be said, therefore, that the power amplifier provided with such Darlington circuits is capable of employing a more compact driver transformer without getting faulty on the performance characteristics. Such a high gain amplifier makes it possible to apply a large amount of negative feedback, improving frequency characteristic and reducing distortion.

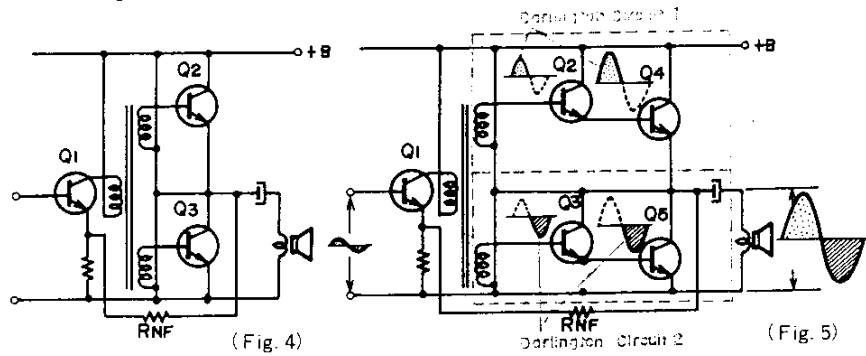

(Fig. 4)

(Fig. 5)

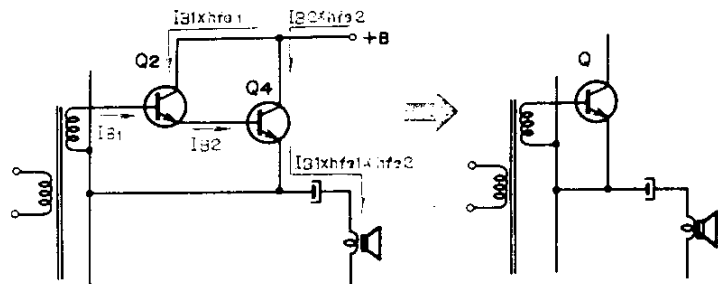

(Fig. 6)

(Fig. 7)

Block Diagram

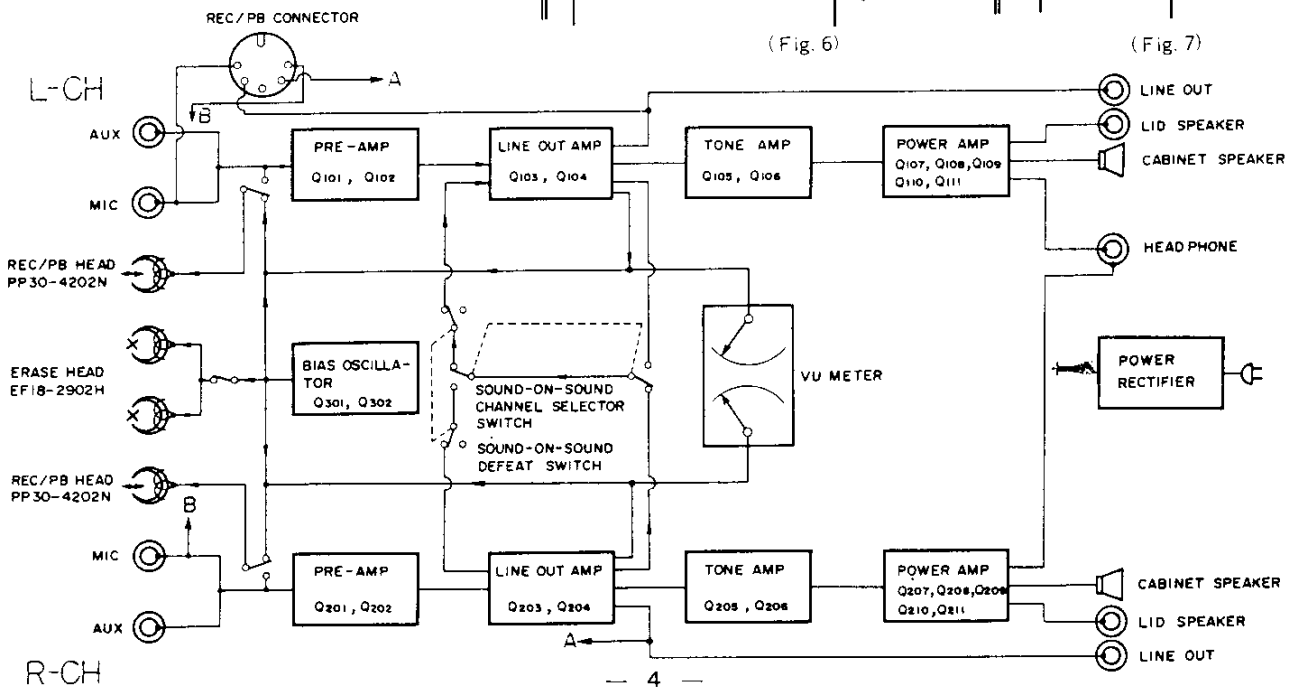

Cabinet Top View

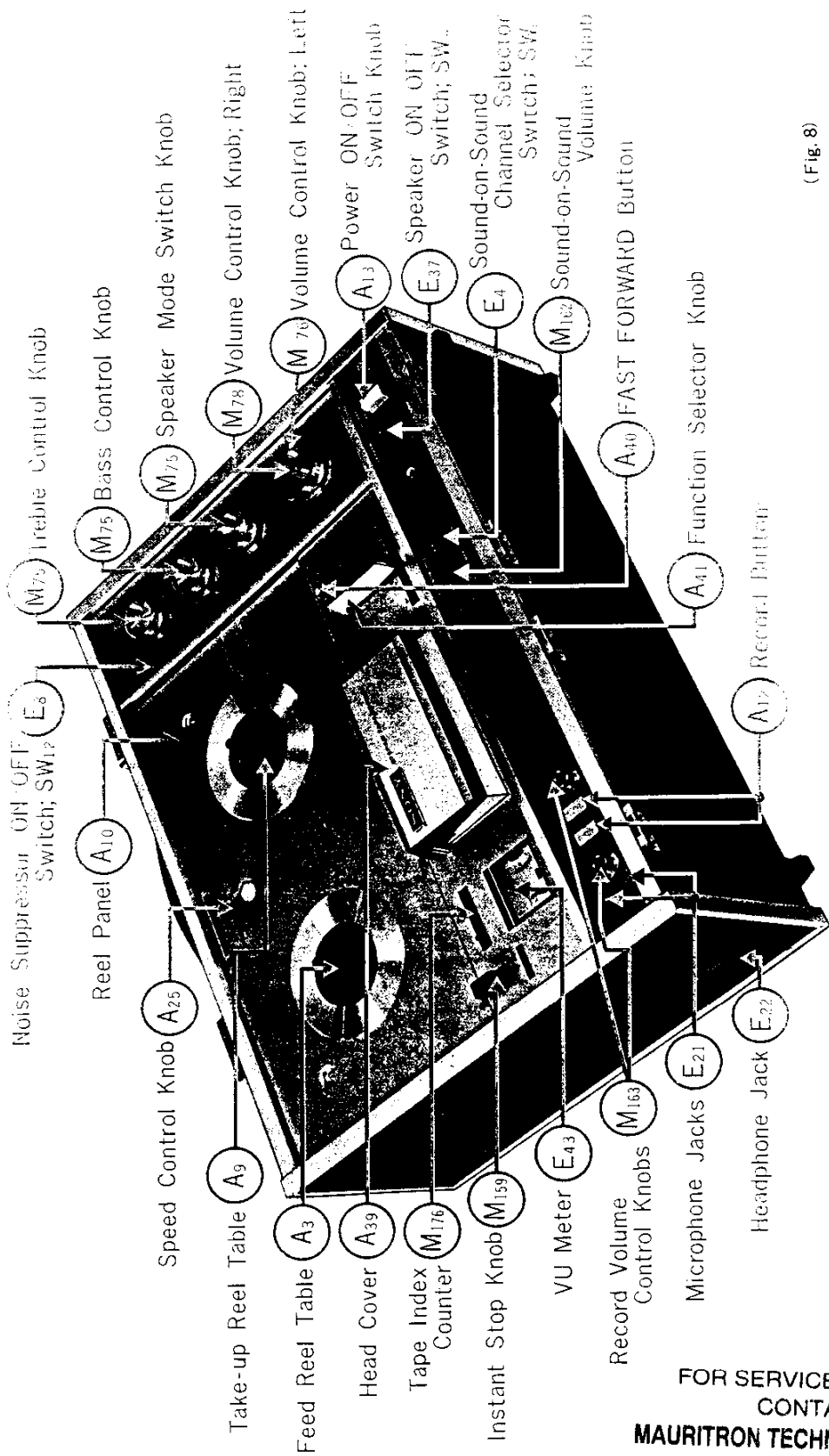

(Fig. 8)

FOR SERVICE MANUALS
CONTACT:
MAURITRON TECHNICAL SERVICES
www.mauritron.co.uk
TEL: 01844 - 351694
FAX: 01844 - 352554

Cabinet Back View

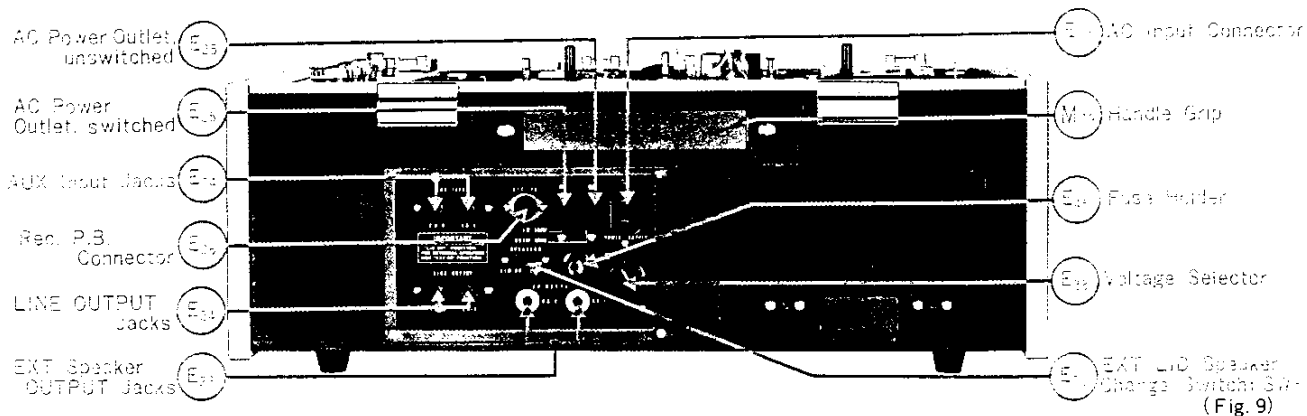

Chassis Bottom View

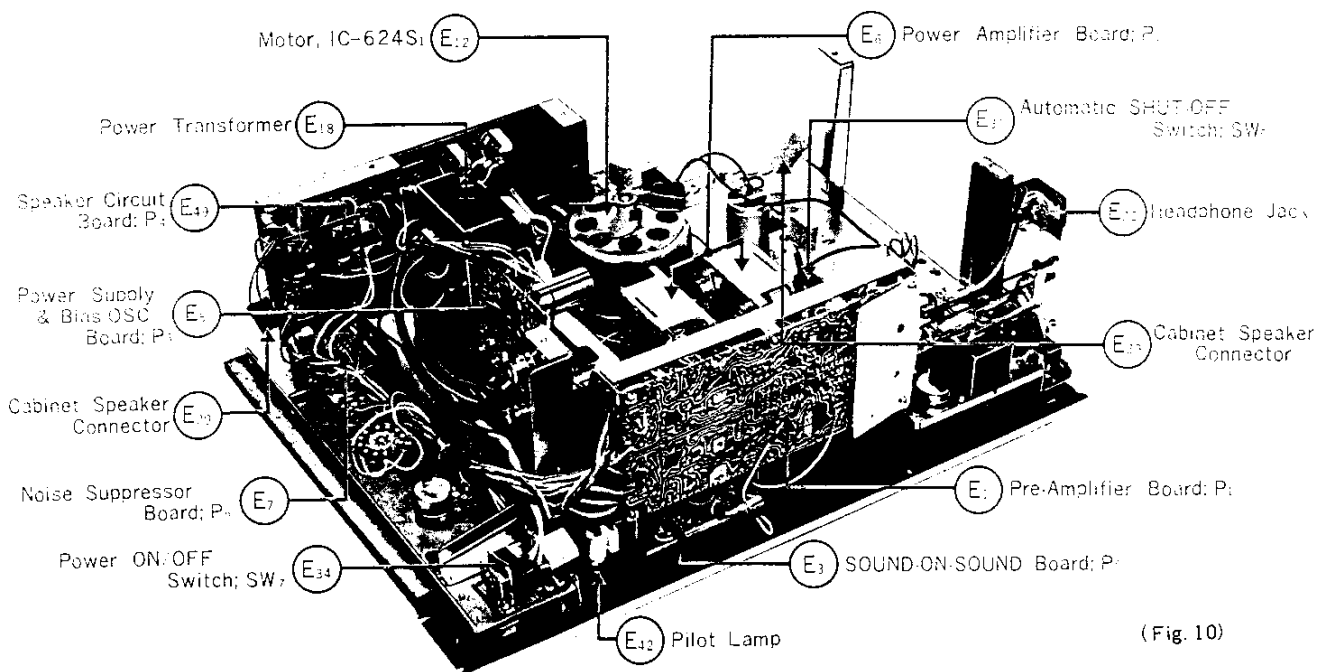

(Fig. 10)

FOR SERVICE MANUALS
CONTACT:
MAURITRON TECHNICAL SERVICE
www.mauritron.co.uk
TEL: 01844 - 351694
FAX: 01844 - 352554

Chassis Top View

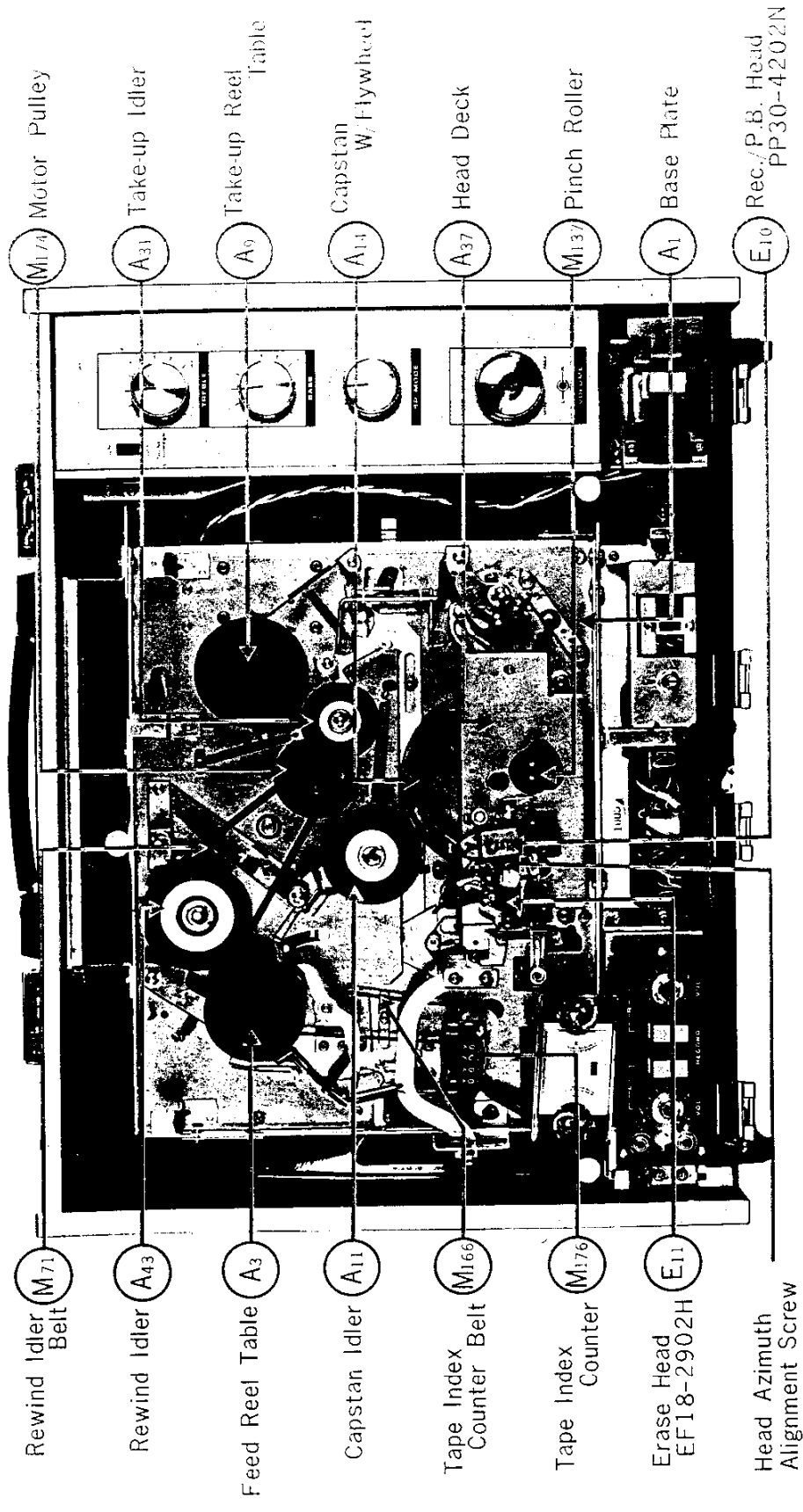

M174 Motor Pulley

A31 Take-up Idler

A9 Take-up Reel Table

A14 Capstan W/ Flywheel

A37 Head Deck

M137 Pinch Roller

A1 Base Plate

E10 Rec./P.B. Head PP30-4202N

M71 Rewind Idler Belt

A43 Rewind Idler

A3 Feed Reel Table

A11 Capstan Idler

M166 Tape Index Counter Belt

M176 Tape Index Counter

E11 Erase Head EF18-2902H

Head Azimuth Alignment Screw

(Fig. 11)

FO
ac
ape

Method of Disassembling the Set

Removal of Knobs and Head Cover

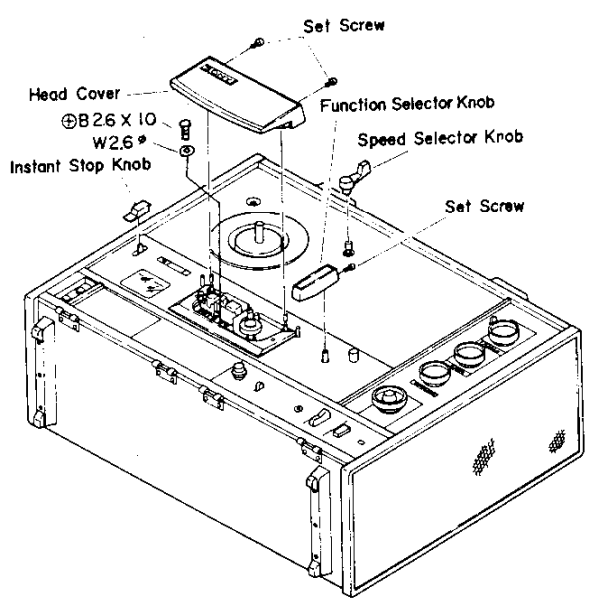

(Fig. 12) FOR SERVICE MANUALS CONTACT:

Removal of Reel Panel

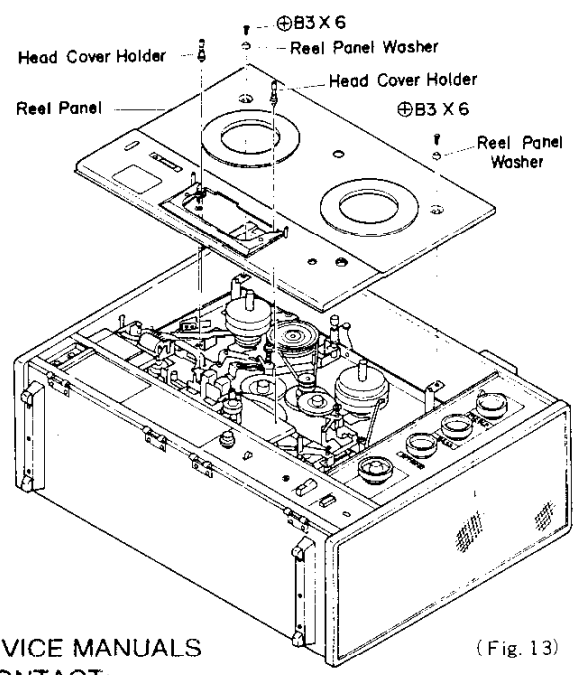

(Fig. 13)

MAURITRON TECHNICAL SERVICES

www.mauritron.co.uk
TEL: 01844 - 351694
FAX: 01844 - 352554



Removal of Cabinet

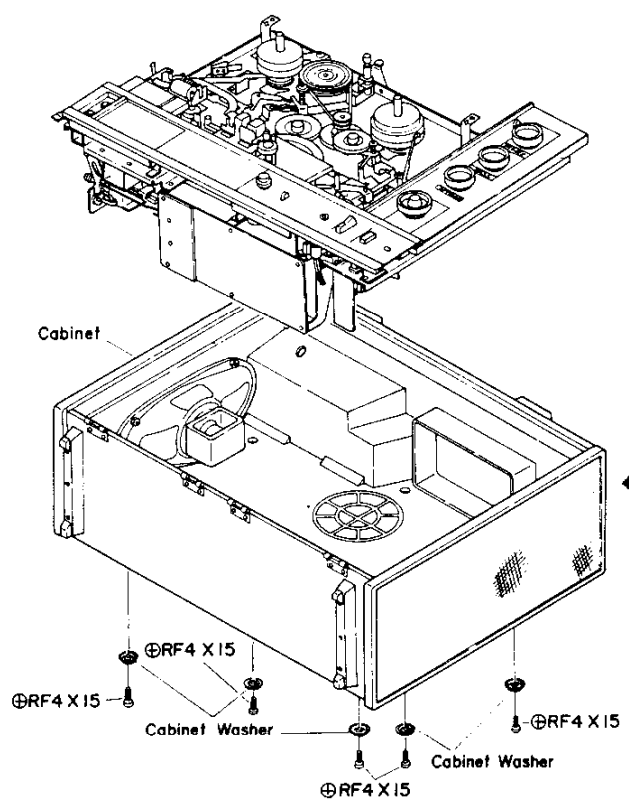

(Fig. 15)

Removal of Carrying Handle

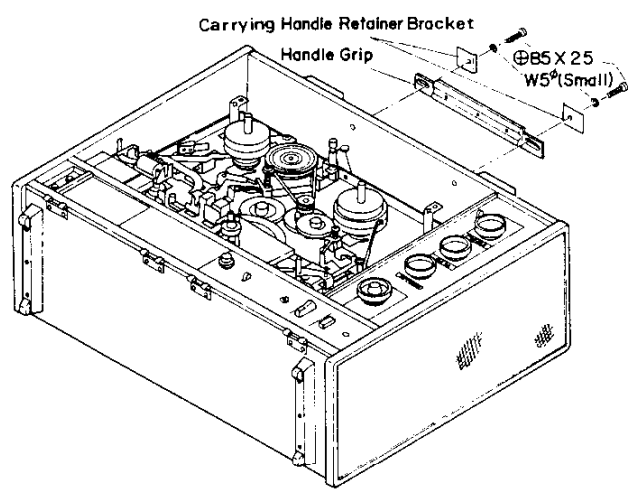

(Fig. 14)

Removal of Mounted Circuit Boards

1. Pre-Amplifier Section

Pre-Amplifier Board can be removed by unscrewing the Screws encircled. (Fig. 16)

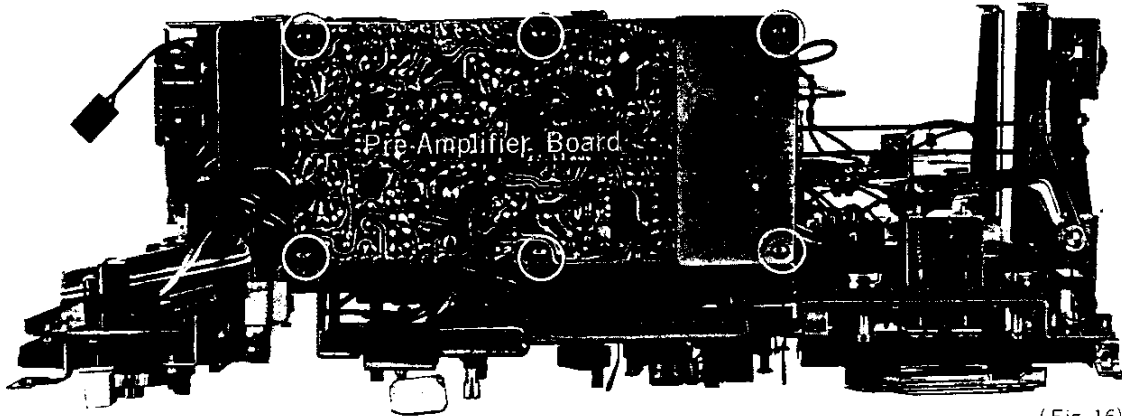

(Fig. 16)

2. Power Amplifier Section

Power Amplifier Board can be removed by unscrewing the Screws encircled. (Fig. 17)

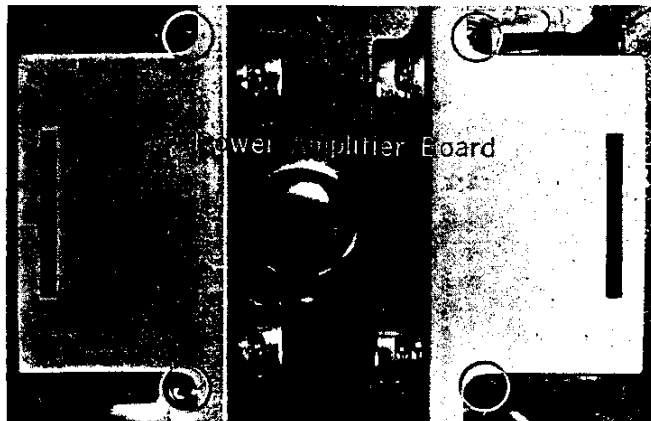

(Fig. 17)

FOR SERVICE MANUALS
CONTACT:
MAURITRON TECHNICAL SERVICES
www.mauritron.co.uk
TEL: 01844 - 351694
FAX: 01844 - 352554

3. Power Supply & Bias OSC Section

Power Supply & Bias OSC Board can be removed by unscrewing the Screws encircled. (Fig. 18)

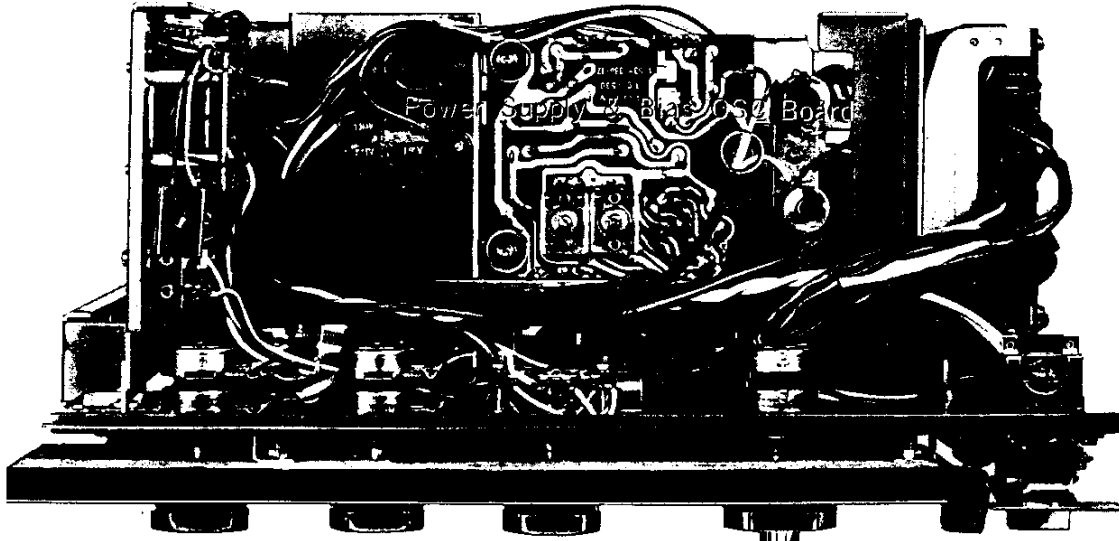

(Fig. 18)

4. Speaker Circuit Section

Speaker Switch Board can be removed by unscrewing the Screws. (Fig. 19)

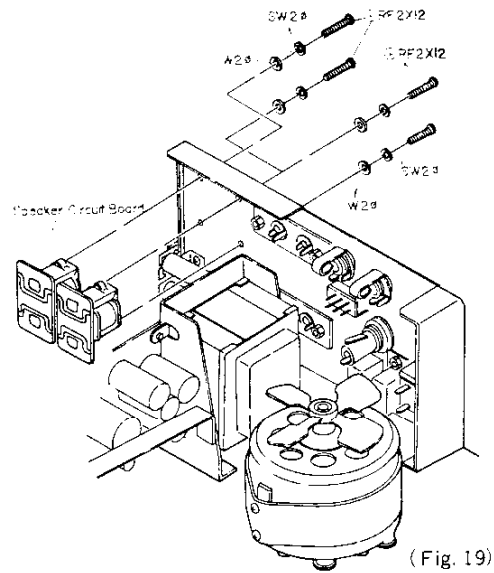

(Fig. 19)

5. SOUND-ON-SOUND Section

SOUND-ON-SOUND Board can be removed by unscrewing the Screws. (Fig. 20)

FOR SERVICE MANUALS
CONTACT:
MAURITRON TECHNICAL SERVICES
www.mauritron.co.uk
TEL: 01844 - 351694
FAX: 01844 - 352554

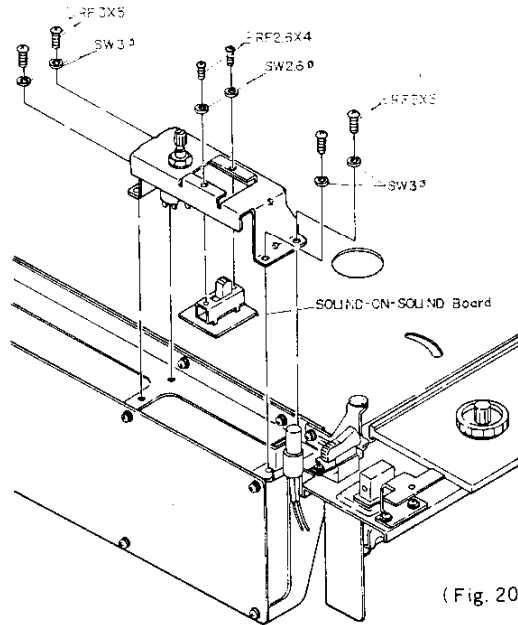

(Fig. 20)

Modification to Different Household Frequency

	For 50 Hz	For 60 Hz
1. Connection between terminals of the Metalized Paper Capacitor	Connected (1.5 μ F ~ 0.5 μ F)	Disconnected (1.5 μ F)
2. Motor Pulley Part Number	3-444-064	3-444-063

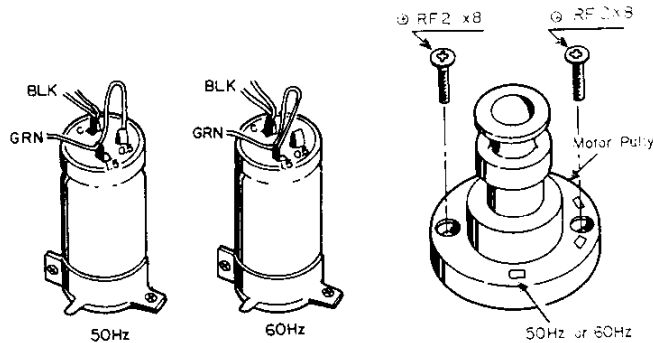

Mechanical Adjustment

A Pinch Roller Shaft Height Adjustment

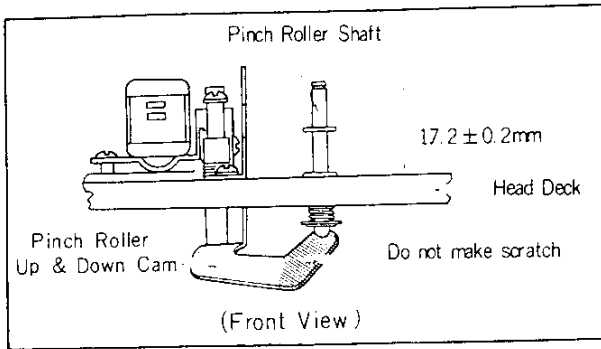

① When adjusting roughly

Adjust by bending with pliers as shown below.

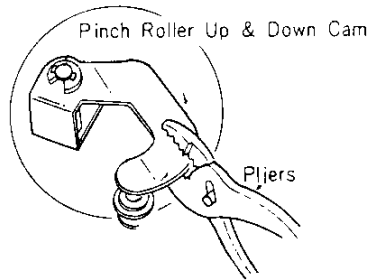

(Bottom View)

② When adjusting accurately

Adjust to obtain $17.2 \pm 0.2\text{mm}$ by loosening Screw and moving Shaft up and down. After fastening Screw, apply Lock Paint.

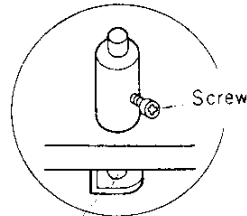

(Top View)

B Head Deck Position Adjustment in FORWARD mode

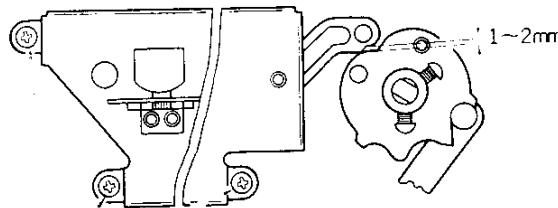

Loosen Screws and adjust the position of Head Deck.
(Top View)

FOR SERVICE MANUALS CONTACT:
MAURITRON TECHNICAL SERVICES
www.mauritron.co.uk
TEL: 01844 - 351694
FAX: 01844 - 352554

C Take-up

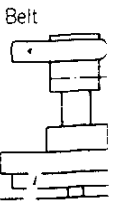

Motor Pulley

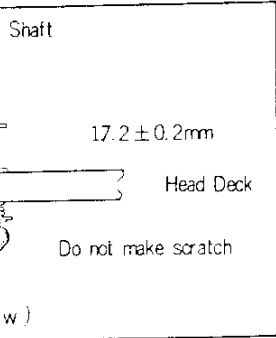

② When adjusting accurately
 Adjust to obtain $17.2 \pm 0.2\text{mm}$ by
 loosening Screw and moving
 Shaft up and down.
 After fastening Screw, apply Lock Paint.

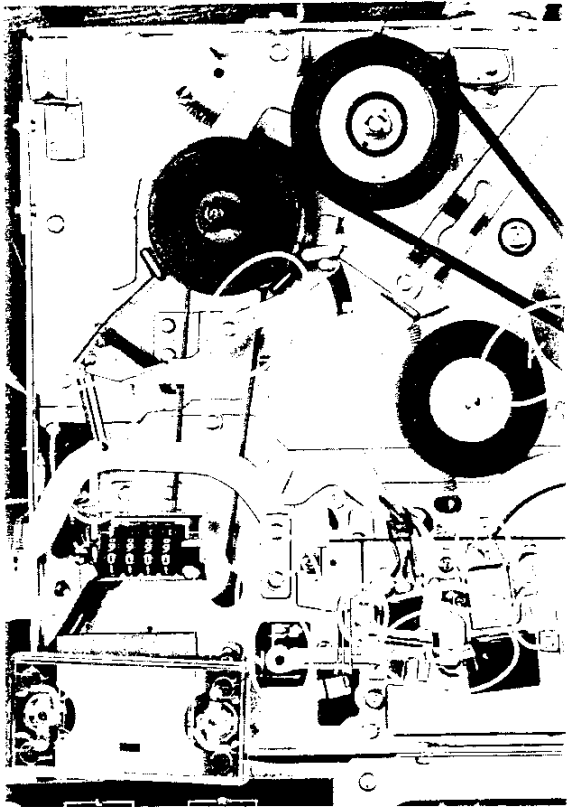
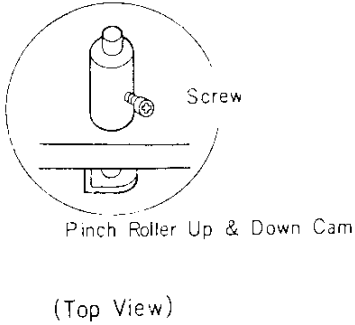

Top View

FORWARD mode

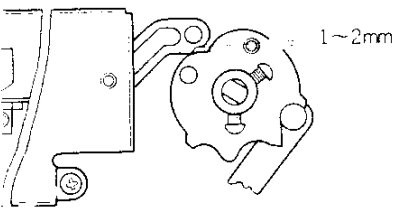

adjust the position of Head Deck.
 (Top View)

in FAST FORWARD mode

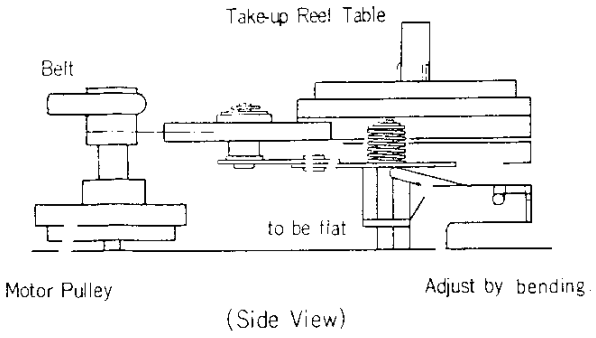

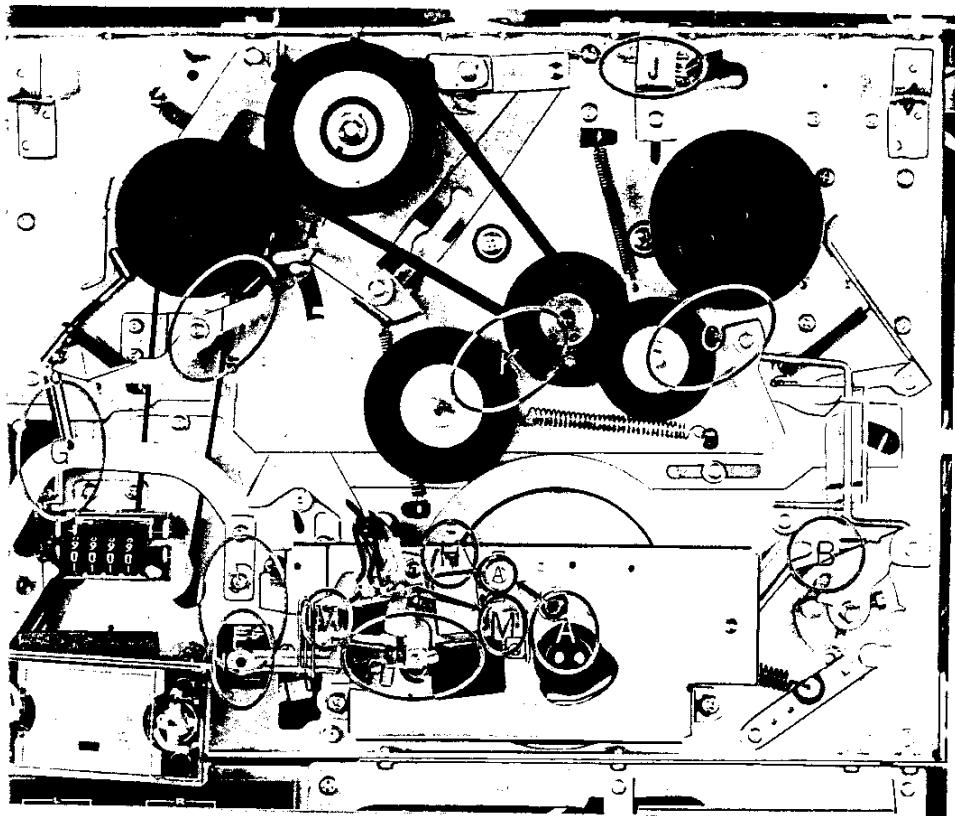

Top View

FOR SERVICE MANUALS
CONTACT:
MAURITRON TECHNICAL SERVICES
www.mauritron.co.uk
TEL: 01844 - 351694
FAX: 01844 - 352554

Reel Height Adjustment
in FORWARD mode

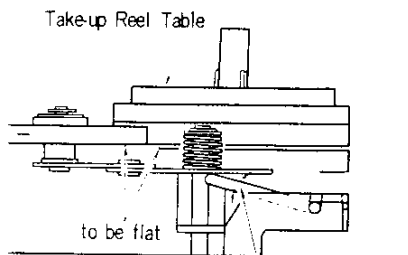

(Side View)

Adjust by bending.

D

Instant Stop Lever Adjustment
in FORWARD mode

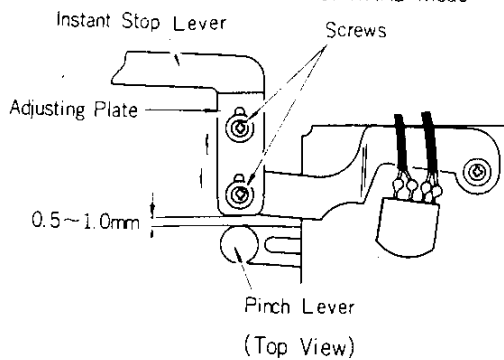

Loosen Screws and adjust the position of Adjusting Plate.

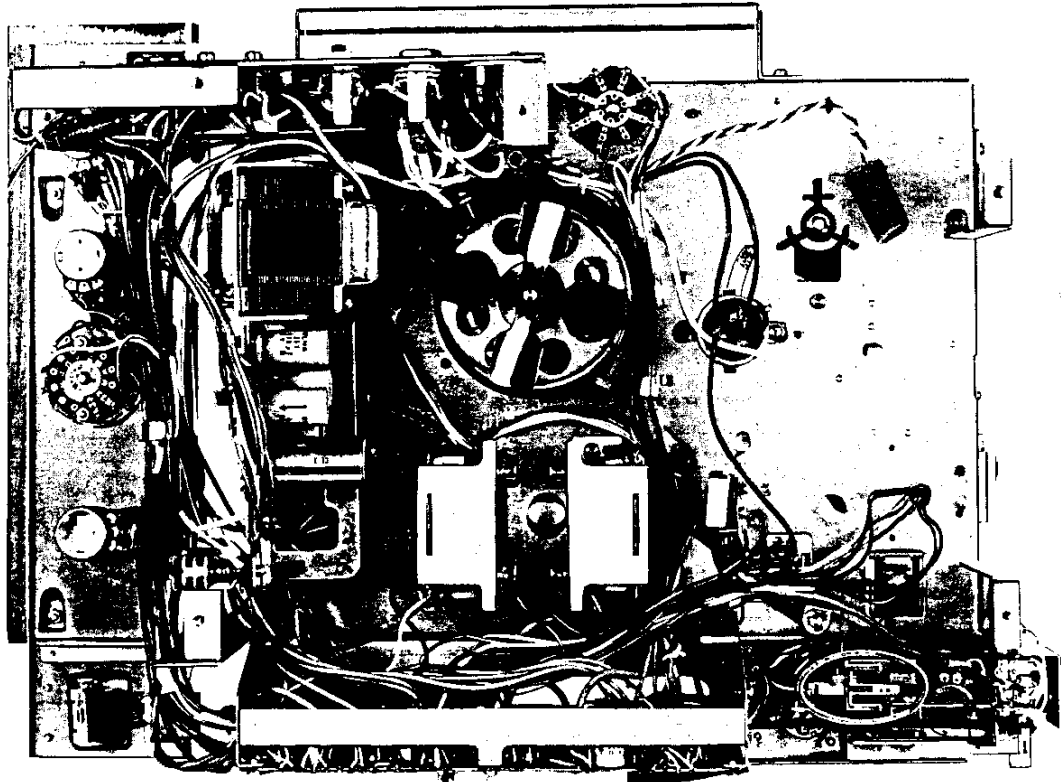

Bottom View

FOR SERVICE MANUALS
CONTACT:
MAURITRON TECHNICAL SERVICES
www.mauritron.co.uk
TEL: 01844 351894
FAX: 01844 352554

E Monaural
in ST

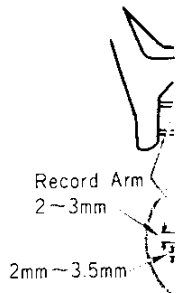

G Bias Of

Loosen

Feed R

Rewind L

Adjust by
bending
with pliers.

Brake shoe



J Bias Control Switch Position Adjustment
at 1 7/8 ips (4.8cm/s) speed Leaf Switch Holder

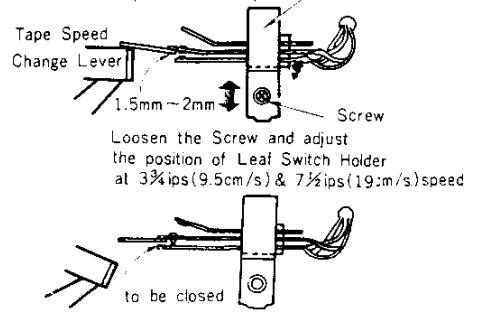

K Capstan Idler Position Adjustment
in STOP mode

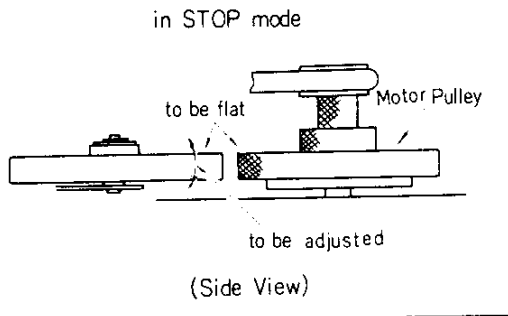

L Tar

Loosen Scr
the positio

to be parallel

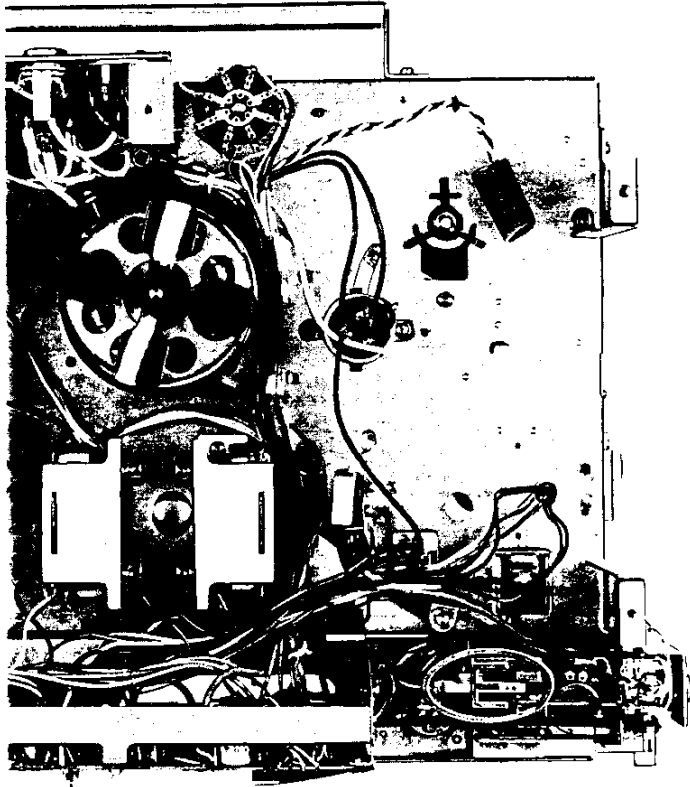

Bottom View

E Monaural Record Switch Adjustment.
in STOP mode

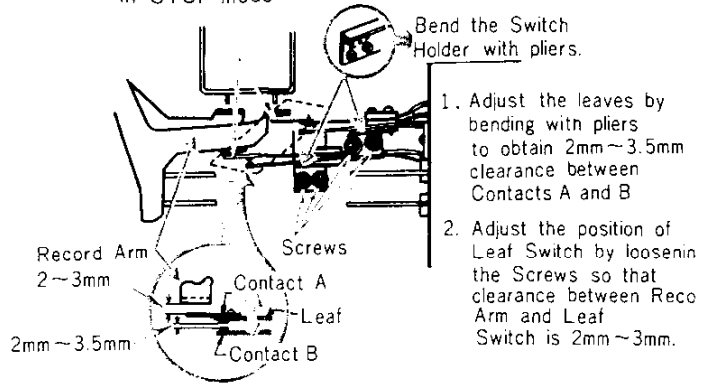

G Bias ON/OFF Switch Position Adjustment
in FORWARD mode

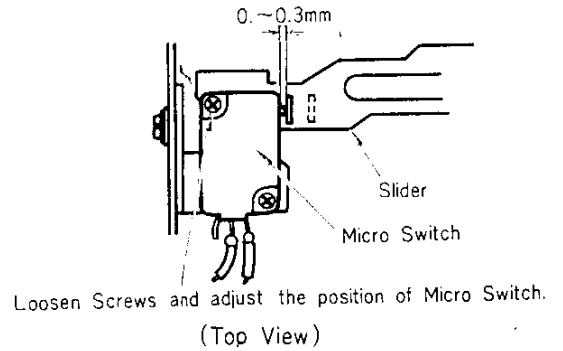

I Feed Reel Table Brake Position Adjustment
in FORWARD mode

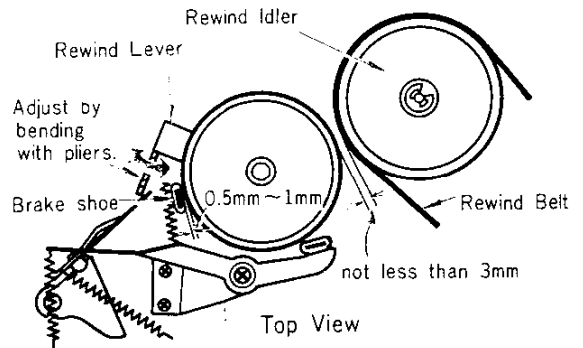

Adjustment
Switch Holder

K Capstan Idler Position Adjustment

in STOP mode

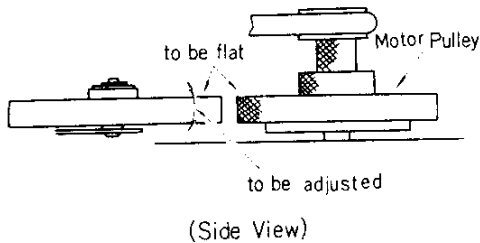

L Tape Shifter Adjustment
in FORWARD mode

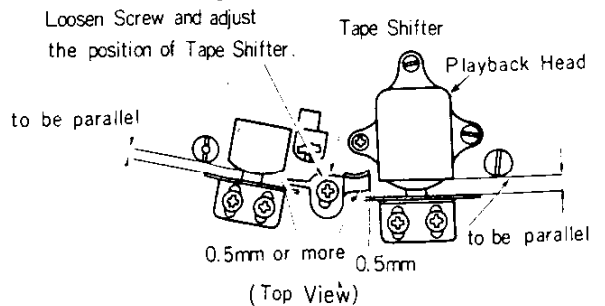

crew
older
19cm/s speed

Record Switch Adjustment.

STOP mode

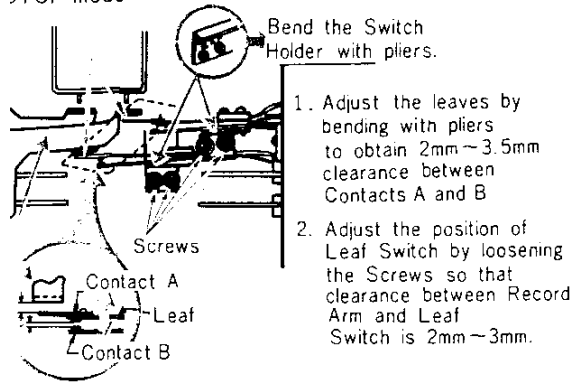

F

Muting Switch Adjustment:

in FAST FORWARD mode

in FORWARD mode

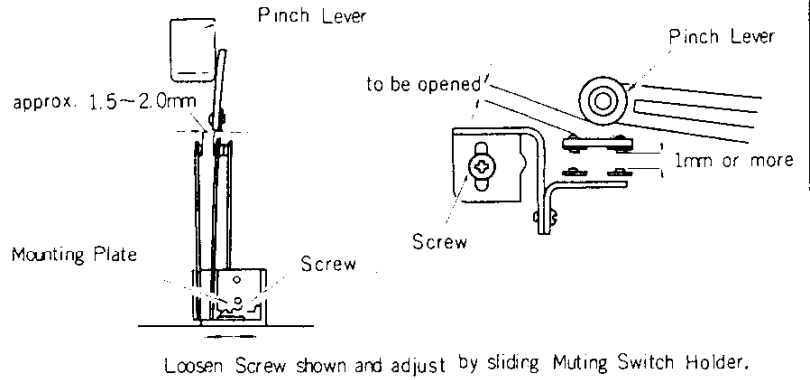

STOP Switch Position Adjustment

in FORWARD mode

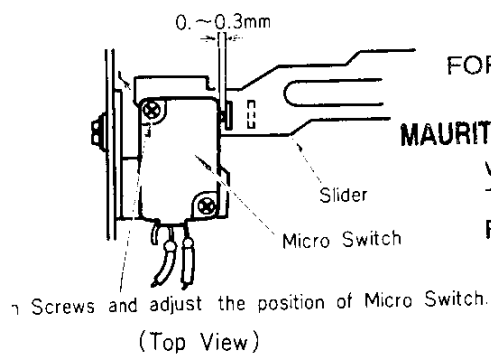

FOR SERVICE MANUALS
CONTACT:
MAURITRON TECHNICAL SERVICES
www.mauritron.co.uk
TEL: 01844 - 351694
FAX: 01844 - 352554

H

Head Mounting Plate Height Adjustment

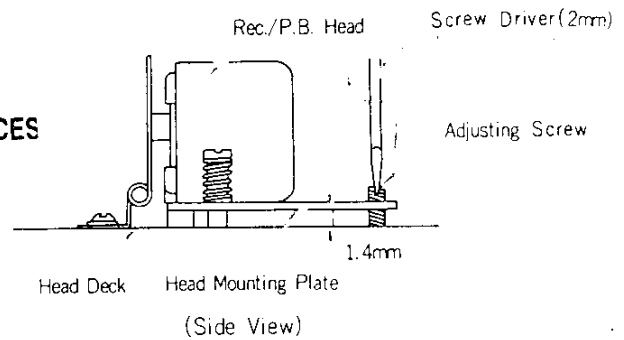

Reel Table Brake Position Adjustment

in FORWARD mode

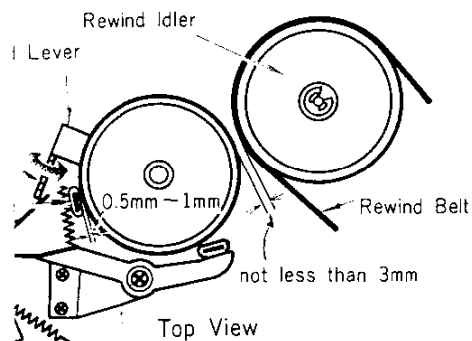

M

Tape Guide Adjustment

in FORWARD mode

1. Keep Head Shield Plate laying down forward by finger tip.
2. Adjust Tape Guide so that Cores are just visible above the top edge of Tape. ★
3. Turn Tape Guide(Right) counterclockwise by approx. 30 degrees as shown in Fig. A and the Tape Guide(Left) clockwise by approx. 30 degrees as shown in Fig. B.

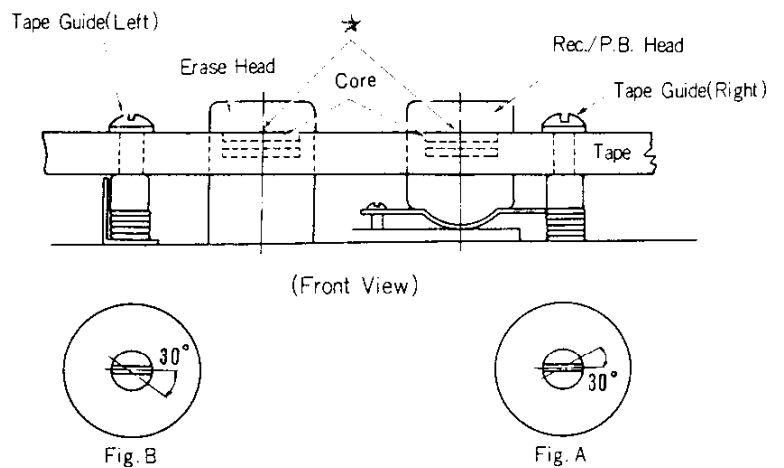

Tape Shifter Adjustment

in FORWARD mode

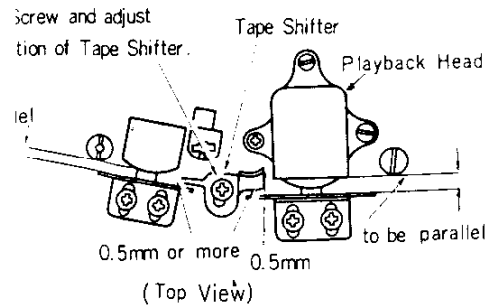

Electrical Adjustment

Item	Signal Source	Output Connection	Mode
1. Playback Azimuth Alignment	10 kHz 1st section of SONY Alignment Tape, J-19-F ₂	VTVM and 100kΩ Resistor in parallel to LINE OUT	Playback
2. Playback Level Adjustment	1 kHz 2nd section of SONY Alignment Tape, J-19-F ₂	VTVM and 100kΩ Resistor in parallel to LINE OUT	Playback
3. Meter Level Adjustment	1 kHz, -60 dBs (0.78 mV) to MIC INPUT	VTVM and 100kΩ Resistor in parallel to LINE OUT	Record
4. Playback Equalizer Adjustment (1); 7½ ips (19 cm/s)	SONY Alignment Tape, J-19-F ₂	VTVM and 100kΩ Resistor in parallel to LINE OUT	Playback
5. Playback Equalizer Adjustment (2); 3¾ ips (9.5 cm/s)	SONY Alignment Tape, J-9-F ₁	VTVM and 100kΩ Resistor in parallel to LINE OUT	Playback
6. Trap Coil Adjustment (1)		VTVM across REC/PB Head	Record
7. Trap Coil Adjustment (2)		VTVM and 100kΩ Resistor in parallel to LINE OUT	Record
8. Recording Bias Adjustment	1 kHz, -72 dBs (0.196 mV) to MIC INPUT	VTVM and 100kΩ Resistor in parallel to LINE OUT	Playback & Record

NOTES:

- (1) The Adjustments should be made in numerical order.
- (2) The Adjustments should be performed in the tape speed of 19 cm/sec. (7½ ips), unless otherwise specified.
- (3) After adjustments, apply Lock Paint to the adjusted parts.
- (4) The following test equipment is to be provided for these adjustments.
 - Audio Generator
 - Attenuator (600 ohms)
 - V. T. V. M.
 - 100K ohm Resistor
 - SONY Alignment Tapes: J-19-F₂ & J-9-F₁
 - Blank Tape
- (5) Bias Voltage across Heads measured with V.T.V.M. shall be:
 - Rec./P.B. Head: Approx. 40 volts
 - Erase Head: Approx. 80 volts

FOR SERVICE MANUALS
CONTACT:
MAURITRON TECHNICAL SERVICES
www.mauritron.co.uk
TEL: 01844 - 351694
FAX: 01844 - 352554

Signal Source	Output Connection	Mode	Adjust	
1st section of SONY Alignment Tape, J-19-F ₂	VTVM and 100kΩ Resistor in parallel to LINE OUT	Playback	Azimuth Alignment Screw See Fig. 22	Adjust to obtain ma.
2nd section of SONY Alignment Tape, J-19-F ₂	VTVM and 100kΩ Resistor in parallel to LINE OUT	Playback	L-CH; R ₁₁₉ L-CH; R ₂₁₉ See Fig. 24	Adjust Adjustable Re
0 dBs (0.78 mV) to MIC IN-	VTVM and 100kΩ Resistor in parallel to LINE OUT	Record	L-CH; R ₁₁₉ 5kΩ (B) R-CH; R ₂₁₉ 5kΩ (B) See Fig. 24	1. Adjust the Record 2. Adjust the Adjust between the red z
1st section of SONY Alignment Tape, J-19-F ₂	VTVM and 100kΩ Resistor in parallel to LINE OUT	Playback	L-CH; R ₁₁₆ 5kΩ (B) R-CH; R ₂₁₆ 5kΩ (B) See Fig. 24	1. Playback 1kHz, 2. Playback the 1: (R ₁₁₆ & R ₂₁₆) to c
2nd section of SONY Alignment Tape, J-9-F ₁	VTVM and 100kΩ Resistor in parallel to LINE OUT	Playback	L-CH; R ₁₁₆ 5kΩ (B) R-CH; R ₂₁₆ 5kΩ (B) See Fig. 24	1. Playback the 50: VTVM. 2. Playback the 5k: the adjustable re
	VTVM across REC/PB Head	Record	L-CH; L ₁₀₃ 20 mH C ₃₀₃ 30~200 P R-CH; L ₂₀₃ 20 mH C ₃₀₄ 30~200 P See Fig. 23	1. Turn the Trimme 2. Adjust the Trap
	VTVM and 100kΩ Resistor in parallel to LINE OUT	Record	L-CH; L ₁₀₁ 200μH R-CH; L ₂₀₁ 200μH See Fig. 24	1. Turn the Record 2. Adjust to obtain
2 dBs (0.196 mV) to MIC	VTVM and 100kΩ Resistor in parallel to LINE OUT	Playback & Record	L-CH; C ₃₀₃ 30~200 P R-CH; C ₃₀₄ 30~200 P See Fig. 23	1. Turn the Recor 2. Feed a Signal c 3. For Bias Adjust 4. Make the high 5. Connect a VTV: 6. Set TC-540 in 7. Set both machi 8. Turn the trimm 9. Turn the trimm 10. The VTVM read Continue to tu maximum value

numerical order.
 in the tape speed of 19 cm/sec. (7½ ips), unless otherwise specified.
 the adjusted parts.
 provided for these adjustments.

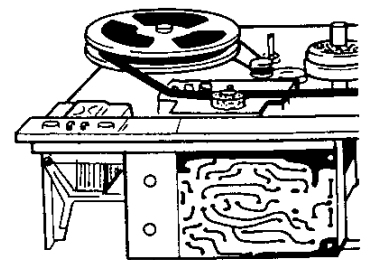

FOR SERVICE MANUALS
 CONTACT:
MAURITRON TECHNICAL SERVICES
www.mauritron.co.uk
 TEL: 01844 - 351694
 FAX: 01844 - 352554

TC-540

Adjust	Remarks
Azimuth Alignment Screw See Fig. 22	Adjust to obtain maximum reading on VTVM.
L-CH; R ₁₁₉ L-CH; R ₂₁₉ See Fig. 24	Adjust Adjustable Resistors (R ₁₁₉ & R ₂₁₉) to obtain 0 dBs (0.775V) on VTVM.
L-CH; R ₁₄₀ 5kΩ (B) R-CH; R ₂₄₀ 5kΩ (B) See Fig. 24	<ol style="list-style-type: none"> 1. Adjust the Record Volumes (R₁₅₇ & R₂₅₇) to obtain +1 dBs (0.89 V) on VTVM. 2. Adjust the Adjustable Resistors (R₁₄₀ & R₂₄₀) so that Level Meters indicate the boundary between the red zone and the white zone.
L-CH; R ₁₁₆ 5kΩ (B) R-CH; R ₂₁₆ 5kΩ (B) See Fig. 24	<ol style="list-style-type: none"> 1. Playback 1kHz, 3rd section of Alignment Tape and measure its response with VTVM. 2. Playback the 12.5kHz, (4th section) of Alignment Tape and adjust the adjustable resistors (R₁₁₆ & R₂₁₆) to obtain just the same response comparing with Step 1.
L-CH; R ₁₁₆ 5kΩ (B) R-CH; R ₂₁₆ 5kΩ (B) See Fig. 24	<ol style="list-style-type: none"> 1. Playback the 500 Hz, (3rd section) of Alignment Tape and measure its response with VTVM. 2. Playback the 5kHz, (4th section) and the 200 Hz, (6th section) of Alignment Tape and adjust the adjustable resistors (R₁₁₆ & R₂₁₆) to obtain just the same response comparing with Step 1.
L-CH; L ₁₀₃ 20 mH C ₃₀₃ 30~200 P R-CH; L ₂₀₃ 20 mH C ₃₀₄ 30~200 P See Fig. 23	<ol style="list-style-type: none"> 1. Turn the Trimmer Capacitors (C₃₀₃ & C₃₀₄) clockwise fully. 2. Adjust the Trap Coils (L₁₀₃ & L₂₀₃) to obtain minimum reading of Bias Voltage Value on VTVM.
L-CH; L ₁₀₁ 200μH R-CH; L ₂₀₁ 200μH See Fig. 24	<ol style="list-style-type: none"> 1. Turn the Record Volumes (R₁₅₇ & R₂₅₇) clockwise fully. 2. Adjust to obtain minimum reading on VTVM.
L-CH; C ₃₀₃ 30~200P R-CH; C ₃₀₄ 30~200P See Fig. 23	<ol style="list-style-type: none"> 1. Turn the Record Volumes (R₁₅₇ & R₂₅₇) clockwise fully. 2. Feed a Signal of 1kHz, -72 dBs (0.196 mV) to MIC Input. 3. For Bias Adjustment, it is recommendable to use another tape recorder besides TC-540. 4. Make the height of their reel panels even and thread a blank tape. (See Fig. 21) 5. Connect a VTVM and 100kΩ resistor in parallel to LINE OUT of the other tape recorder. 6. Set TC-540 in RECORD mode and the other in PLAYBACK mode. 7. Set both machines to 7½ ips (19 cm/s) or 3¾ ips (9.5 cm/s). 8. Turn the trimmer capacitors fully counter-clockwise. 9. Turn the trimmer capacitors clockwise slowly. 10. The VTVM reading will go up, reaching maximum and then falling again. Continue to turn the trimmer capacitor until the VTVM reads 0.5 dB below from the maximum value.

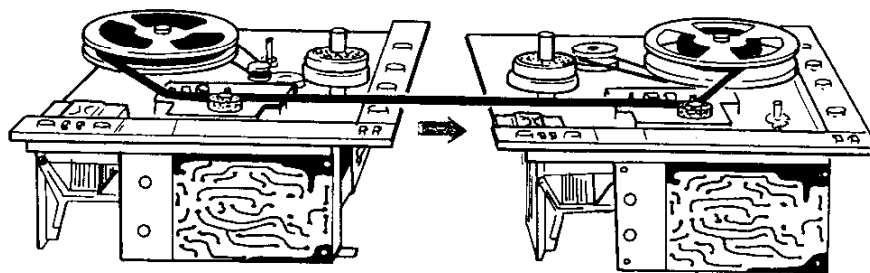
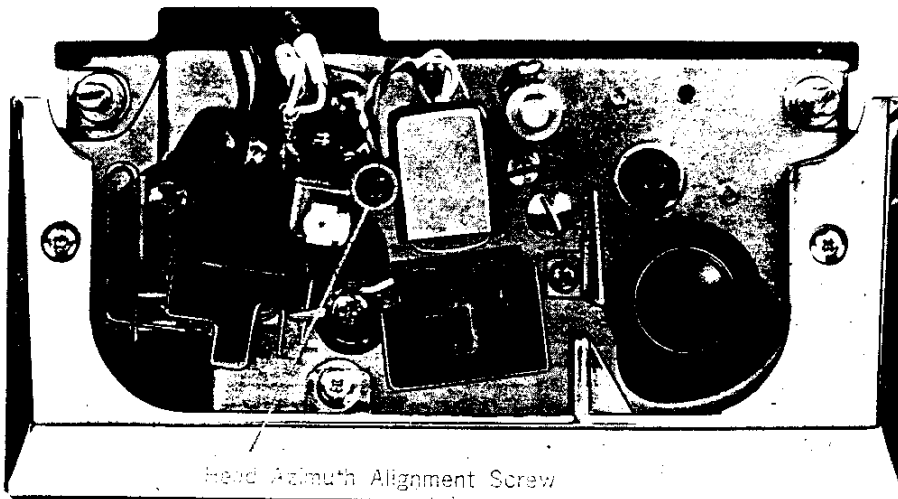

Fig. 21

TC-540

Other Tape Recorder



(Fig. 22)

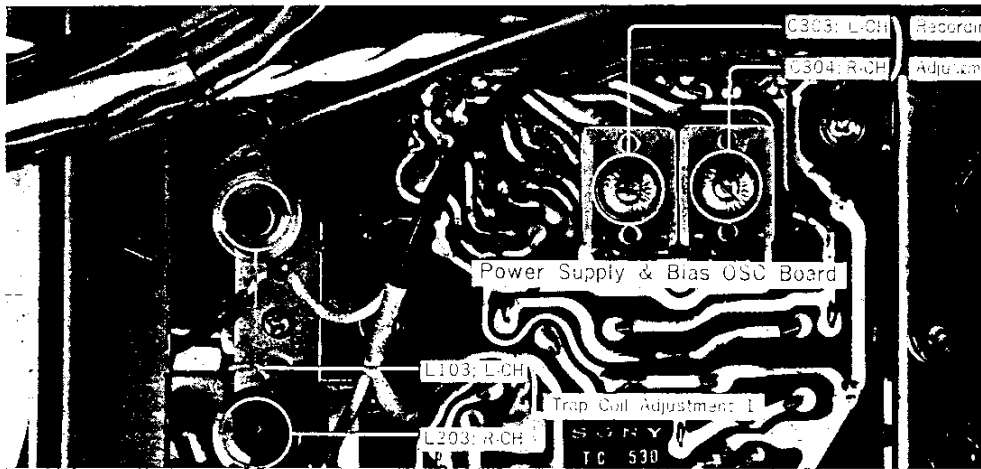

(Fig. 23)

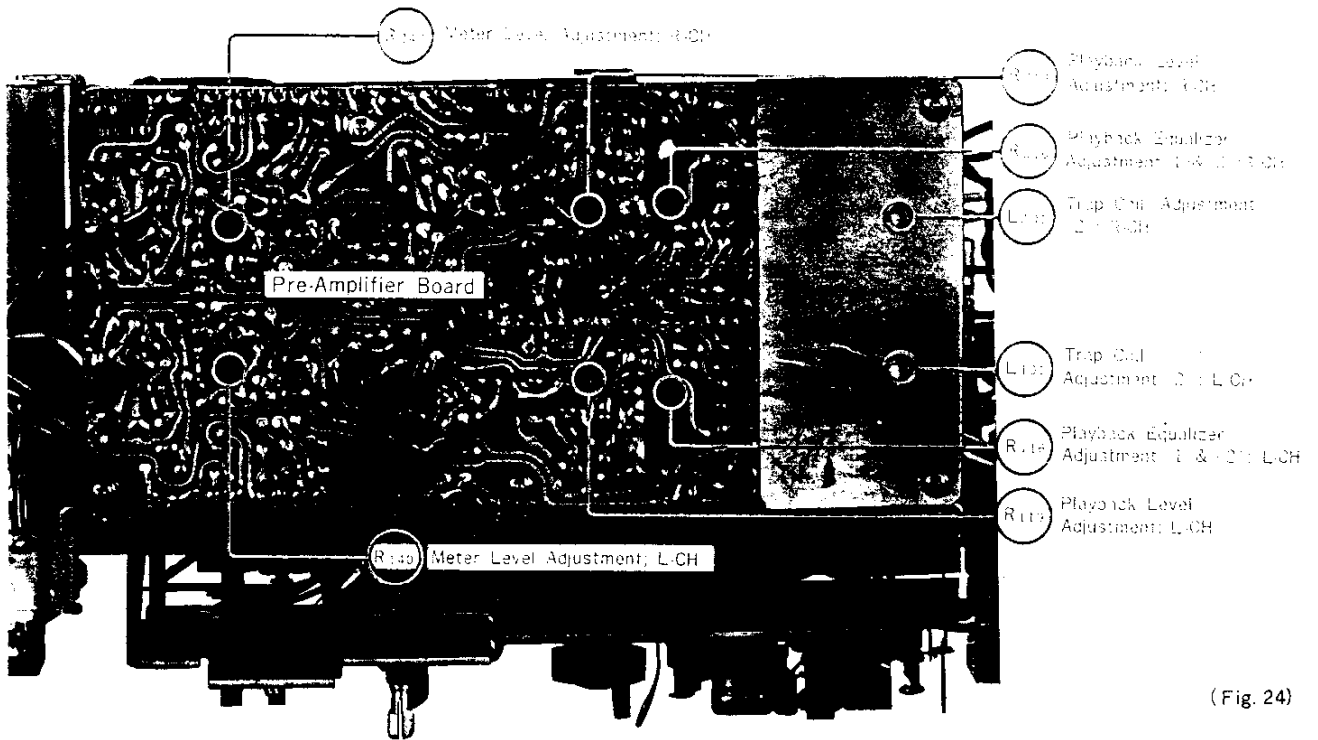

(Fig. 24)

Recording

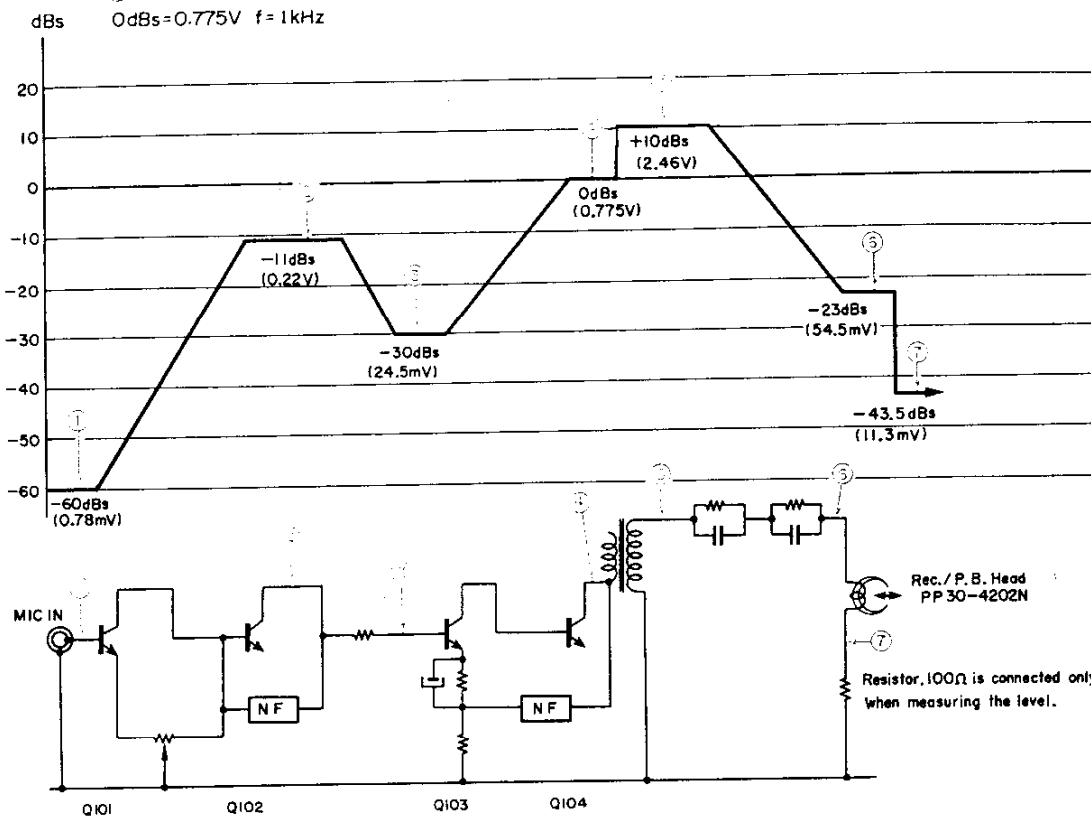

FOR SERVICE MANUALS
CONTACT:

MAURITRON TECHNICAL SERVICES

www.mauritron.co.uk

TEL: 01844 - 351894

FAX: 01844 - 352554

Playback

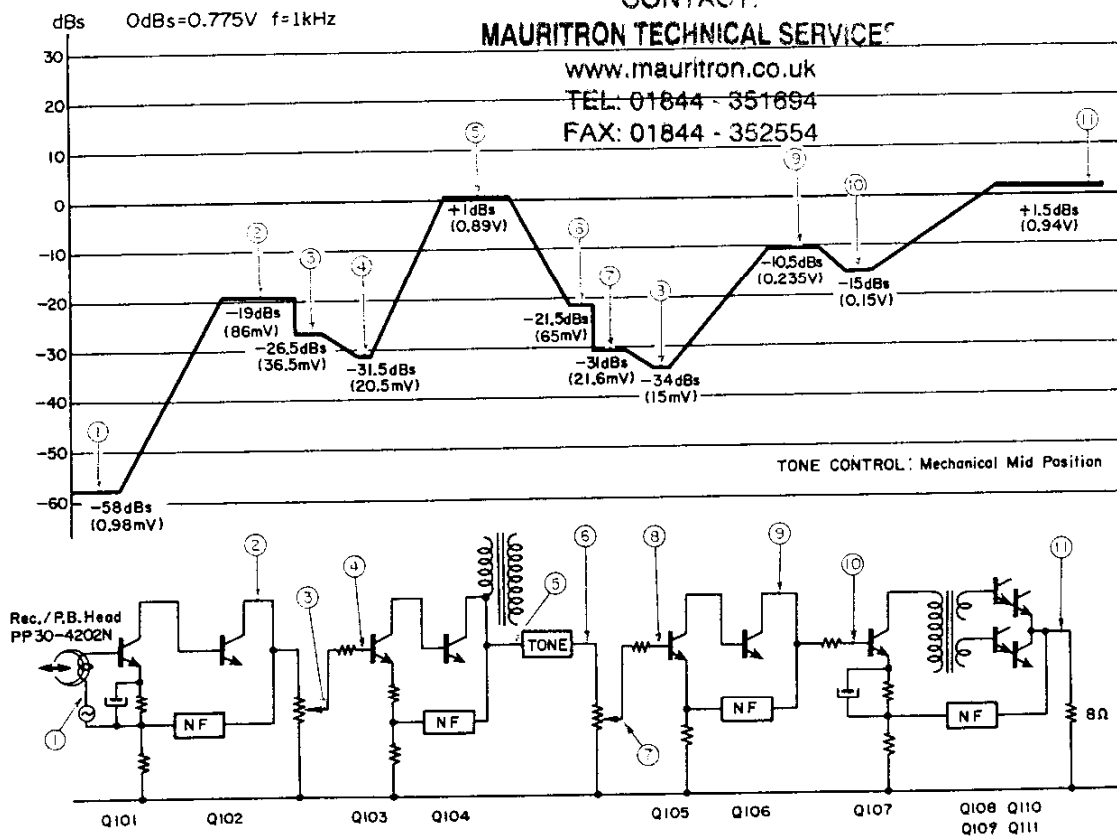

Functions of Mechanism

Tape Transport Mechanism Section

in STOP mode

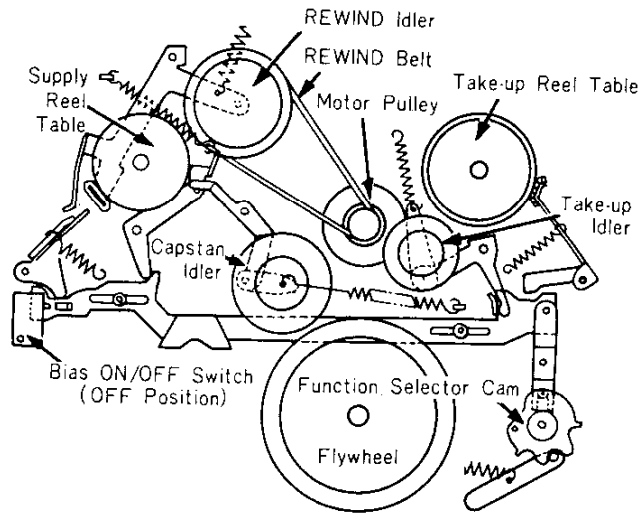

FORWARD mode

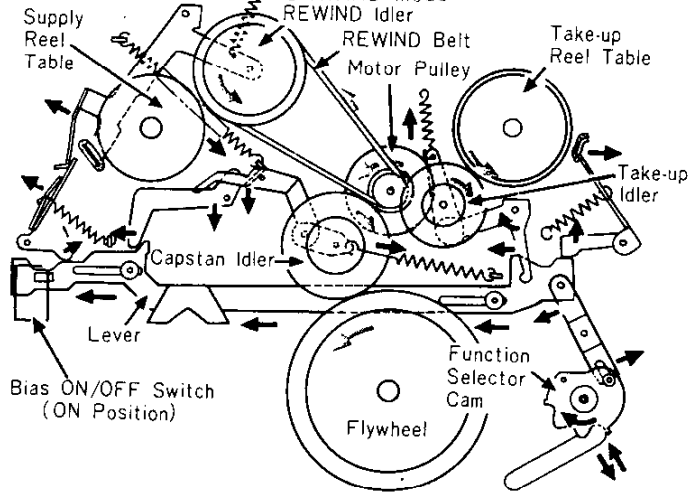

in REWIND mode

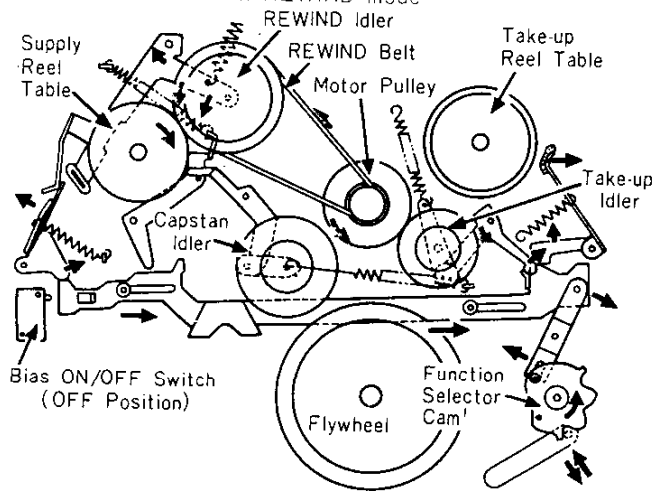

in FAST FORWARD mode

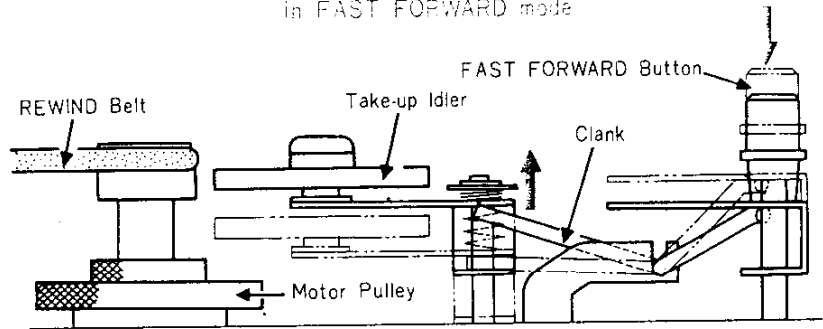

at 7 1/2 ips (19cm/s) speed

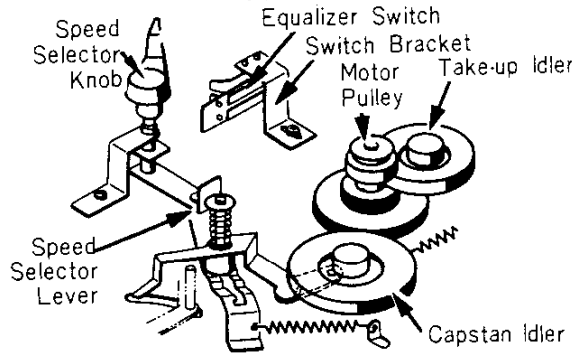

FOR SERVICE MANUALS
CONTACT:
MAURITRON TECHNICAL SERVICES
www.mauritron.co.uk
TEL: 01844 - 351694
FAX: 01844 - 352554

at 1 7/8 ips (4.8cm/s) speed

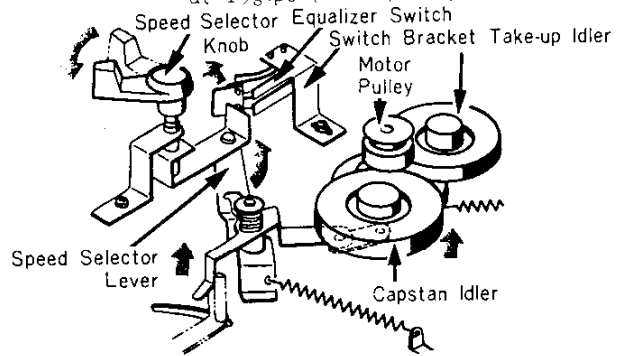

at 3 3/4 ips (9.5cm/s) speed

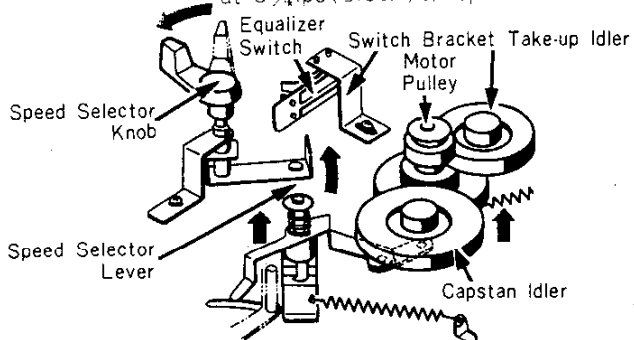

Wiring Diagram

GROUND-OFF-SOUND VOL.

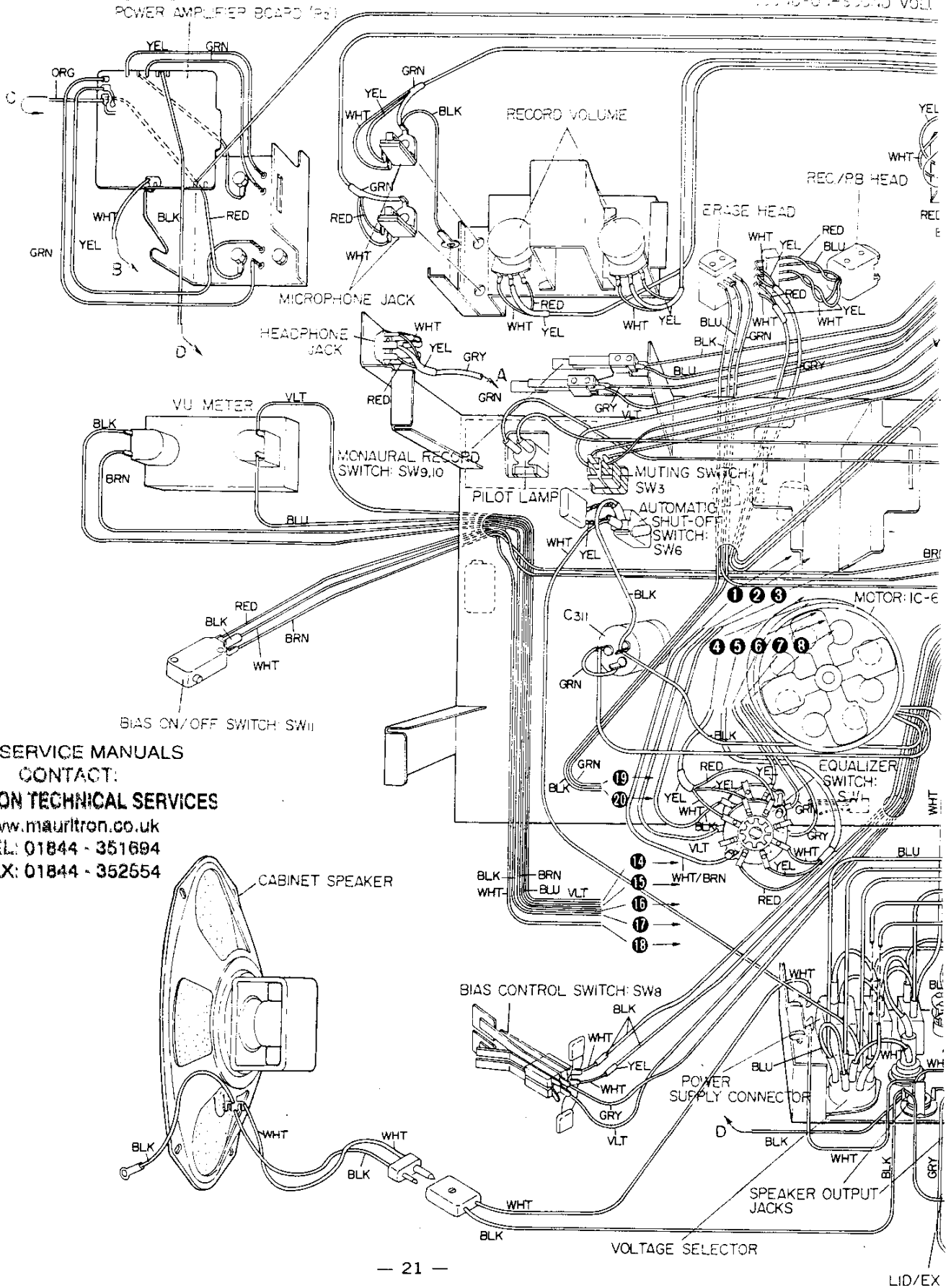

FOR SERVICE MANUALS
CONTACT:
MAURITRON TECHNICAL SERVICES
www.mauritron.co.uk
TEL: 01844 - 351694
FAX: 01844 - 352654

LID/EX

TC-540 TC-540

SOUND-ON-SOUND VOLUME W/ DEFEAT SWITCH SOUND-ON-SOUND BOARD (P5) POWER AMPLIFIER BOA

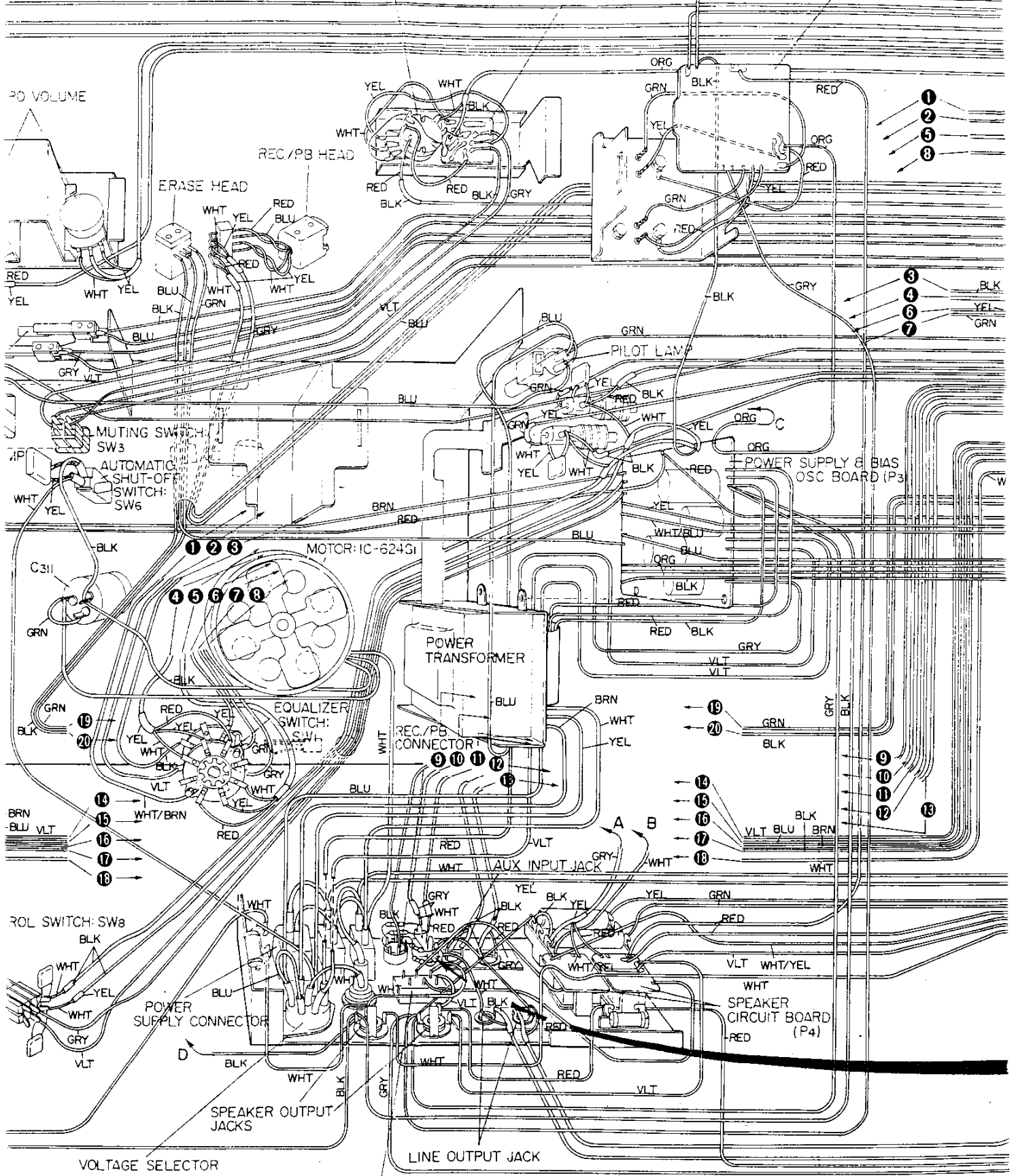

L/D/EXT. SPEAKER CHANGE SWITCH: SW5

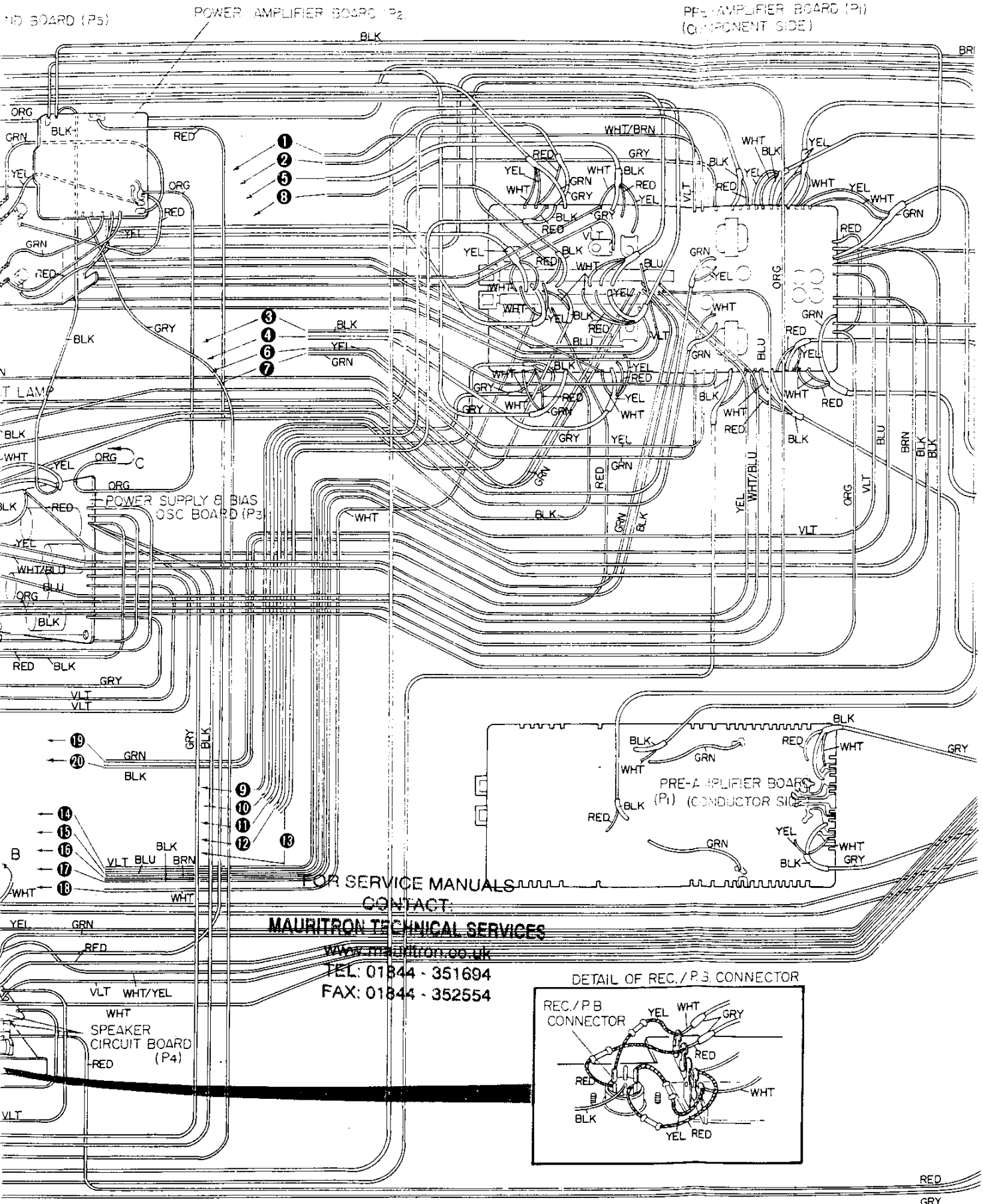

FOR SERVICE MANUALS
CONTACT:

MAURITRON TECHNICAL SERVICES

www.mauritron.co.uk
TEL: 01844 - 351694
FAX: 01844 - 352554

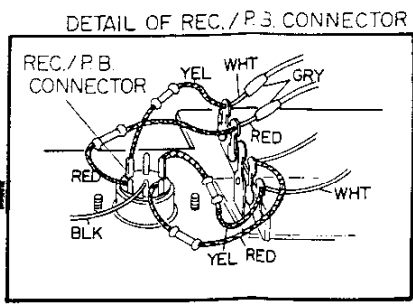

PRE-AMPLIFIER BOARD (P1)
(COMPONENT SIDE)

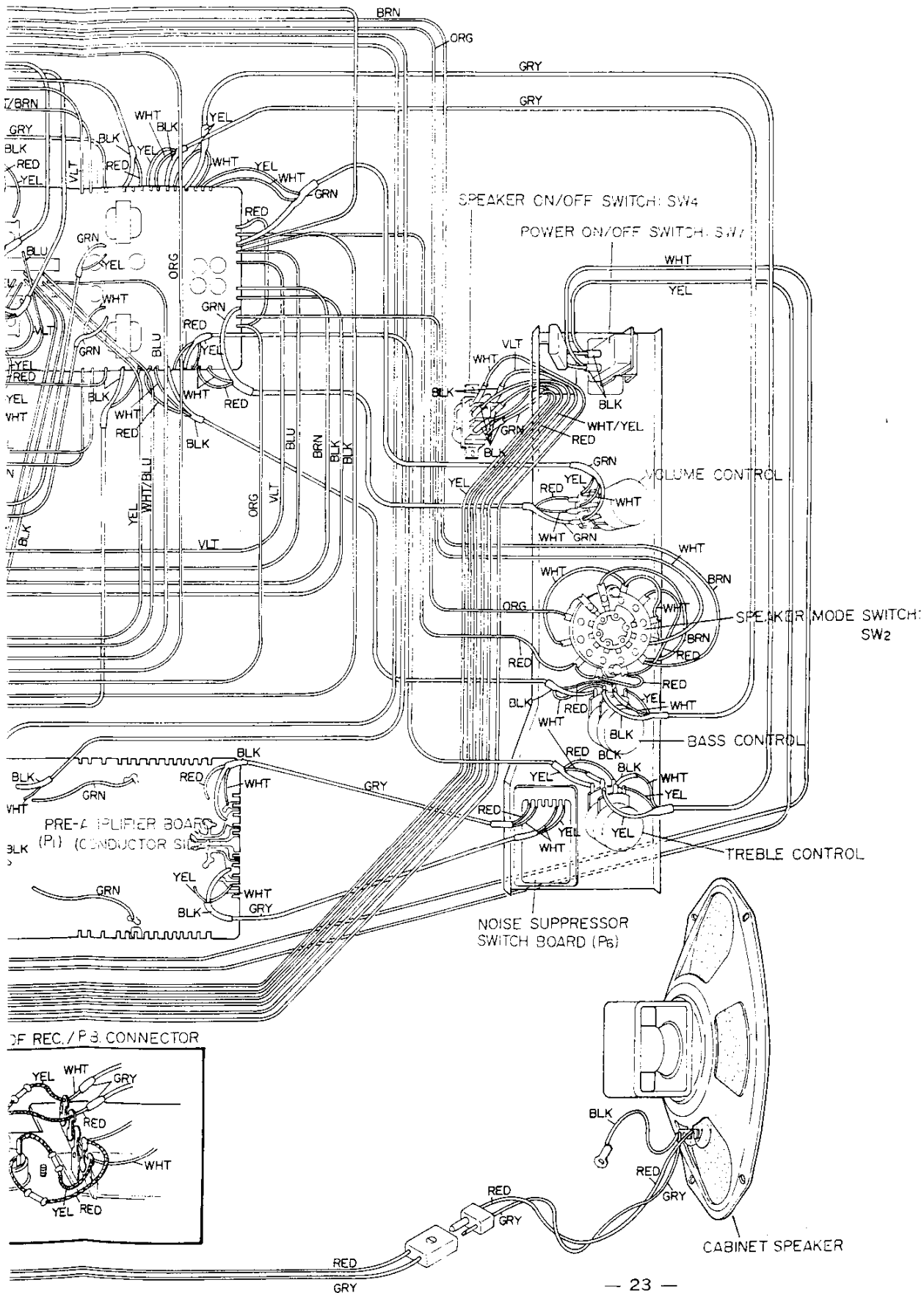

Mounting Diagram

Noise Suppress Switch Board Section

Component Side

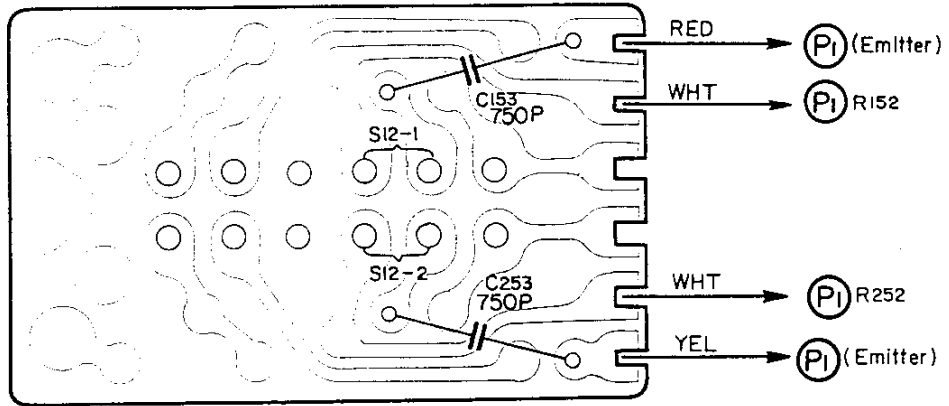

Component Side

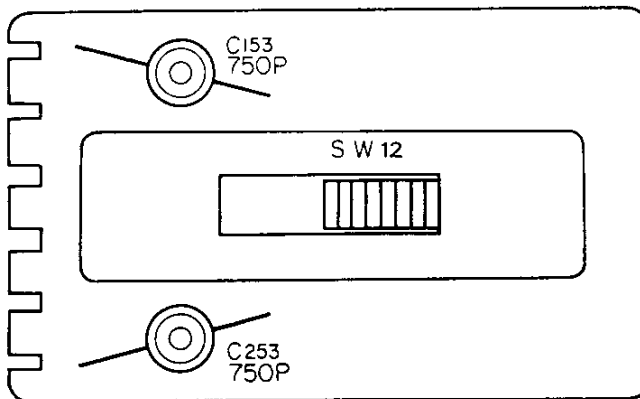

FOR SERVICE MANUALS
CONTACT:
MAURITRON TECHNICAL SERVICES
www.mauritron.co.uk
TEL: 01844 - 351694
FAX: 01844 - 352554

Schematic Diagram

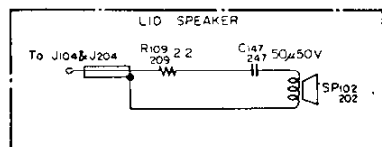
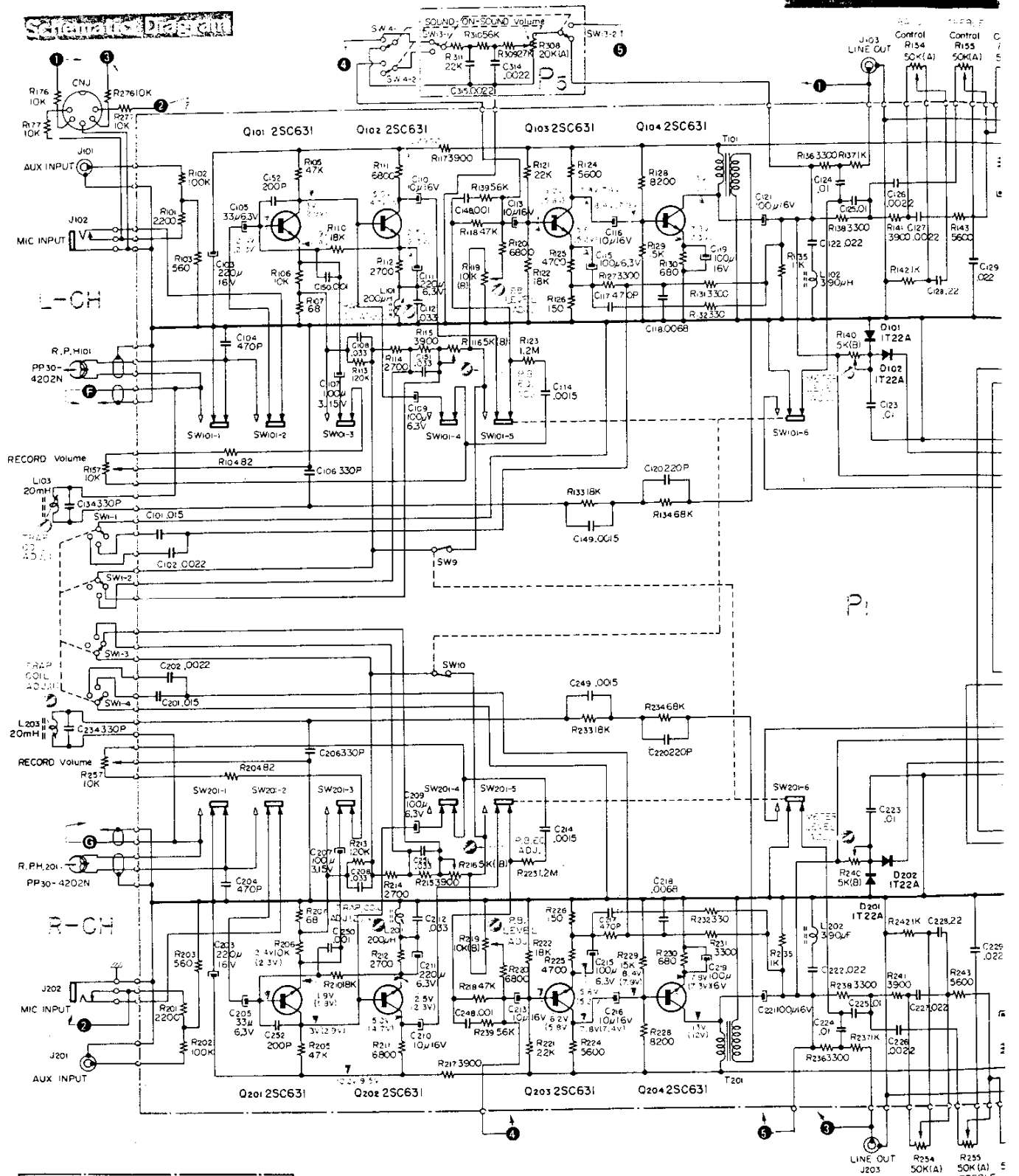

Notes:

1. Switch Positions shown this diagram are as per the table below.

Switch No.	Description	Position
SW ₁₀₁₋₁₂₀	Record/Playback Switch	Record
SW ₁	Equalizer Switch	7 1/2 ips (19 cm/s)
SW ₂	Speaker Mode Switch	Stereo
SW ₃	Muting Switch	OFF
SW ₄	Speaker ON/OFF Switch	ON
SW ₅	EXT-LID Speaker Change Switch	ON
SW ₆	Automatic SHUT-OFF Switch	OFF

Switch No.	Description
SW ₇	Power ON/OFF Switch
SW ₈	Bias Control Switch
SW ₉₋₁₀	Monaural Record Switch
SW ₁₁	Bias ON/OFF Switch
SW ₁₂	Noise Suppressor ON/OFF Switch
SW ₁₃	SOUND-ON-SOUND Channel Selector
SW ₁₄	SOUND-ON-SOUND Defeat Switch

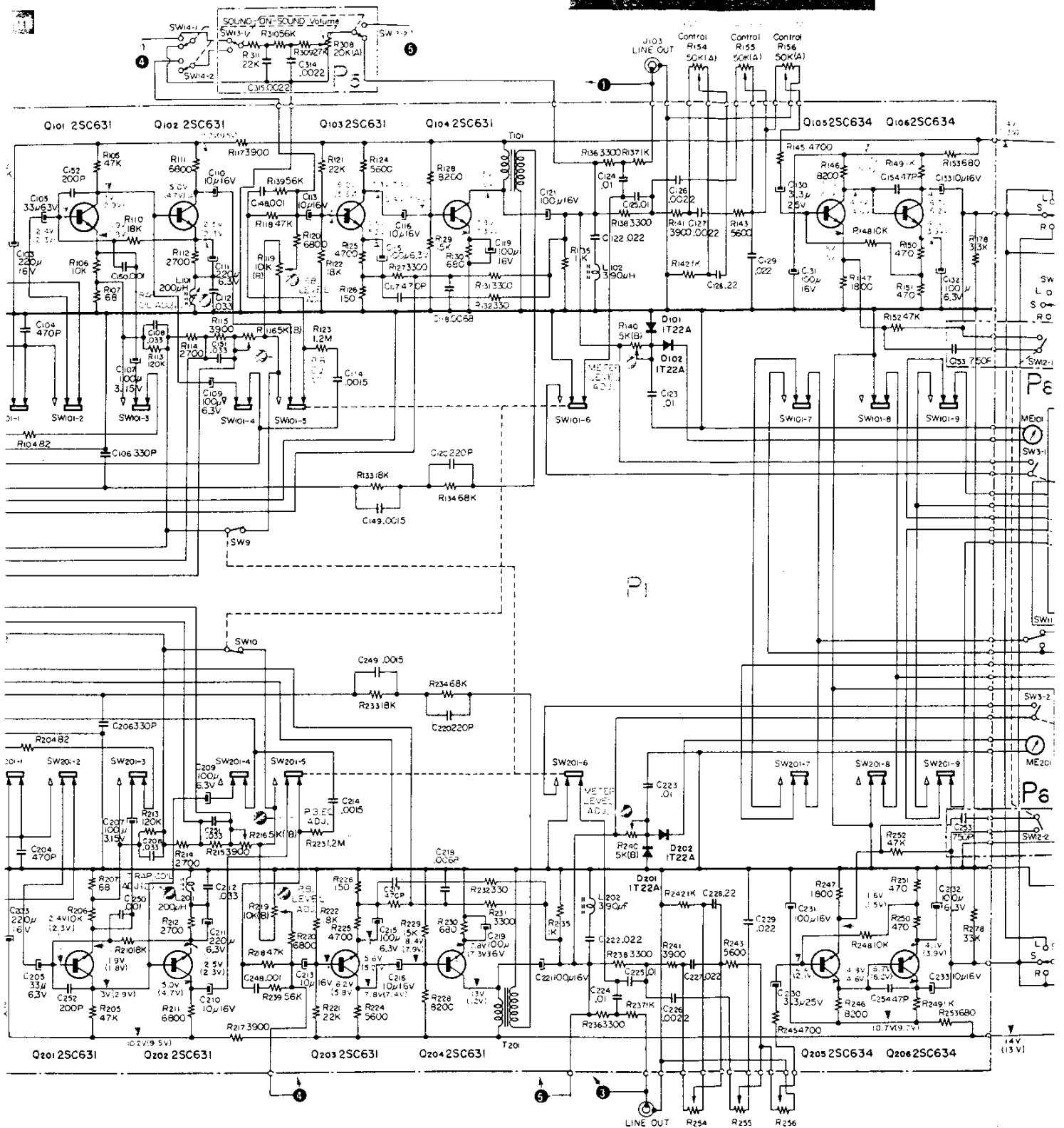

Notes:

1. Switch Positions shown this diagram are as per the table below

Switch No.	Description	Position
SW _{101, 106}	Record/Playback Switch	Record
SW ₁	Equalizer Switch	7 1/2 ips (19 cm/s)
SW ₂	Speaker Mode Switch	Stereo
SW ₃	Muting Switch	OFF
SW ₄	Speaker ON/OFF Switch	ON
SW ₅	EXT-LID Speaker Change Switch	ON
SW ₆	Automatic SHUT-OFF Switch	OFF

Switch No.	Description	Position
SW ₇	Power ON/OFF Switch	OFF
SW ₈	Bias Control Switch	OFF (1 1/2 ips, 4.8 cm/s) ON (3 1/2 ips, 9.5 cm/s) & (7 1/2 ips, 19 cm/s)
SW _{9, 10}	Monaural Record Switch	ON
SW ₁₁	Bias ON/OFF Switch	FORWARD
SW ₁₂	Noise Suppressor ON/OFF Switch	OFF
SW ₁₃	SOUND-ON-SOUND Channel Selector Switch	L-CH-R-CH
SW ₁₄	SOUND-ON-SOUND Defeat Switch	OFF

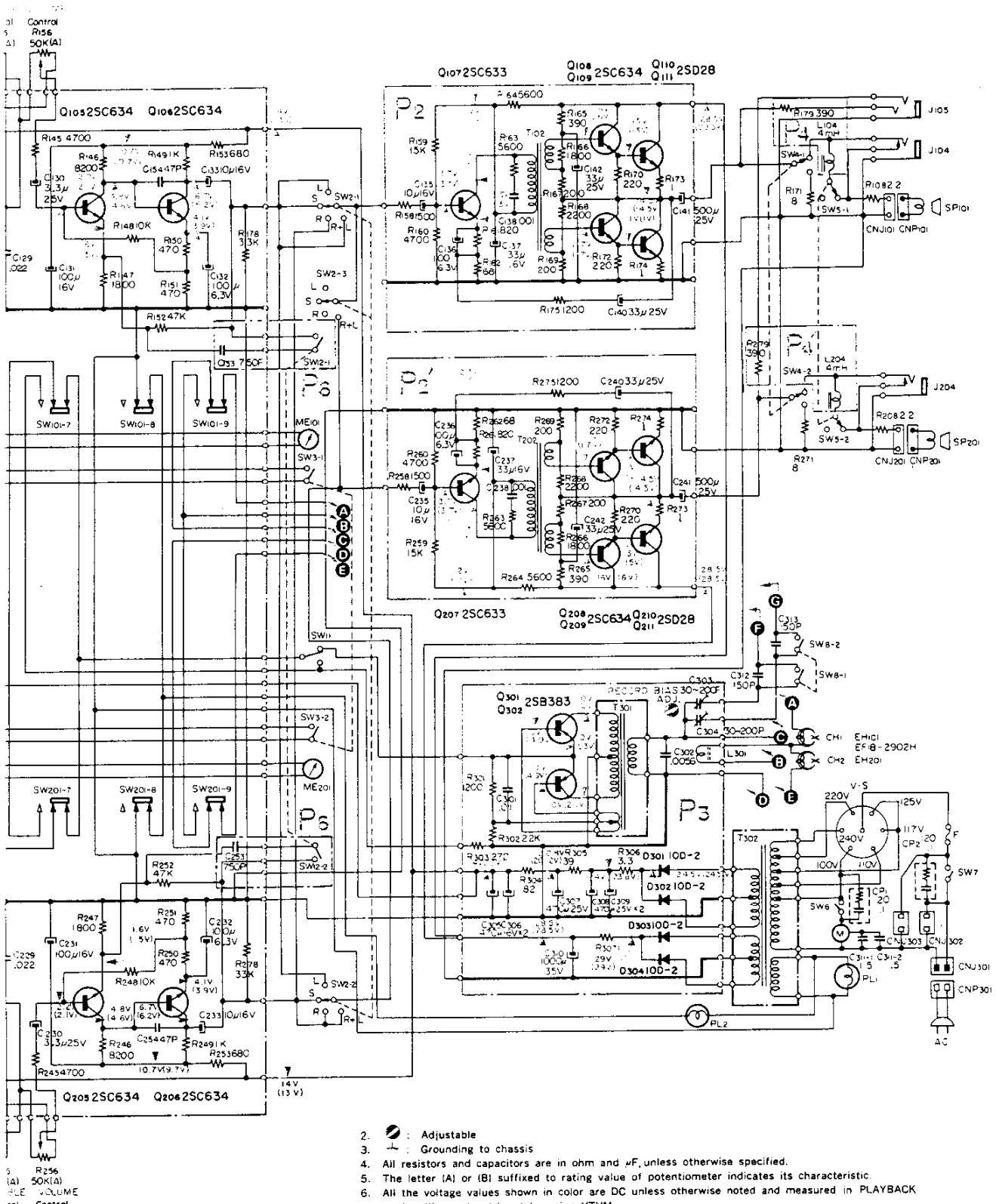

R256
(A) 50K(A)
FILE VOLUME
ral Control

	Position
OFF	OFF (1 1/4 ips, 4.8 cm/s)
ON	ON (3 1/4 ips, 9.5 cm/s) & (7 1/4 ips, 19 cm/s)
ON	FORWARD
OFF	OFF
CH	L-CH-R-CH
h	OFF

2. : Adjustable
3. : Grounding to chassis
4. All resistors and capacitors are in ohm and μ F, unless otherwise specified.
5. The letter (A) or (B) suffixed to rating value of potentiometer indicates its characteristic.
6. All the voltage values shown in color are DC unless otherwise noted and measured in PLAYBACK mode with no signal input by using VTVM. Voltage values in RECORD mode enclosed in parentheses. Variation may be noted because of normal production tolerance.
7. P₁: Pre-Amplifier Circuit Board.
P₂: Power Amplifier Circuit Board.
P₃: Power Supply & Bias OSC Circuit Board.
P₄: Speaker Circuit Board.
P₅: SOUND-ON-SOUND Circuit Board.
P₆: Noise Suppressor Switch Circuit Board.

FOR SERVICE MANUALS
CONTACT:
MAURITRON TECHNICAL SERVICES
www.mauritron.co.uk
TEL: 01844 - 351694
FAX: 01844 - 352554

MOUNTING DIAGRAM

Pre-Amplifier Board Section P₁
Conductor Side

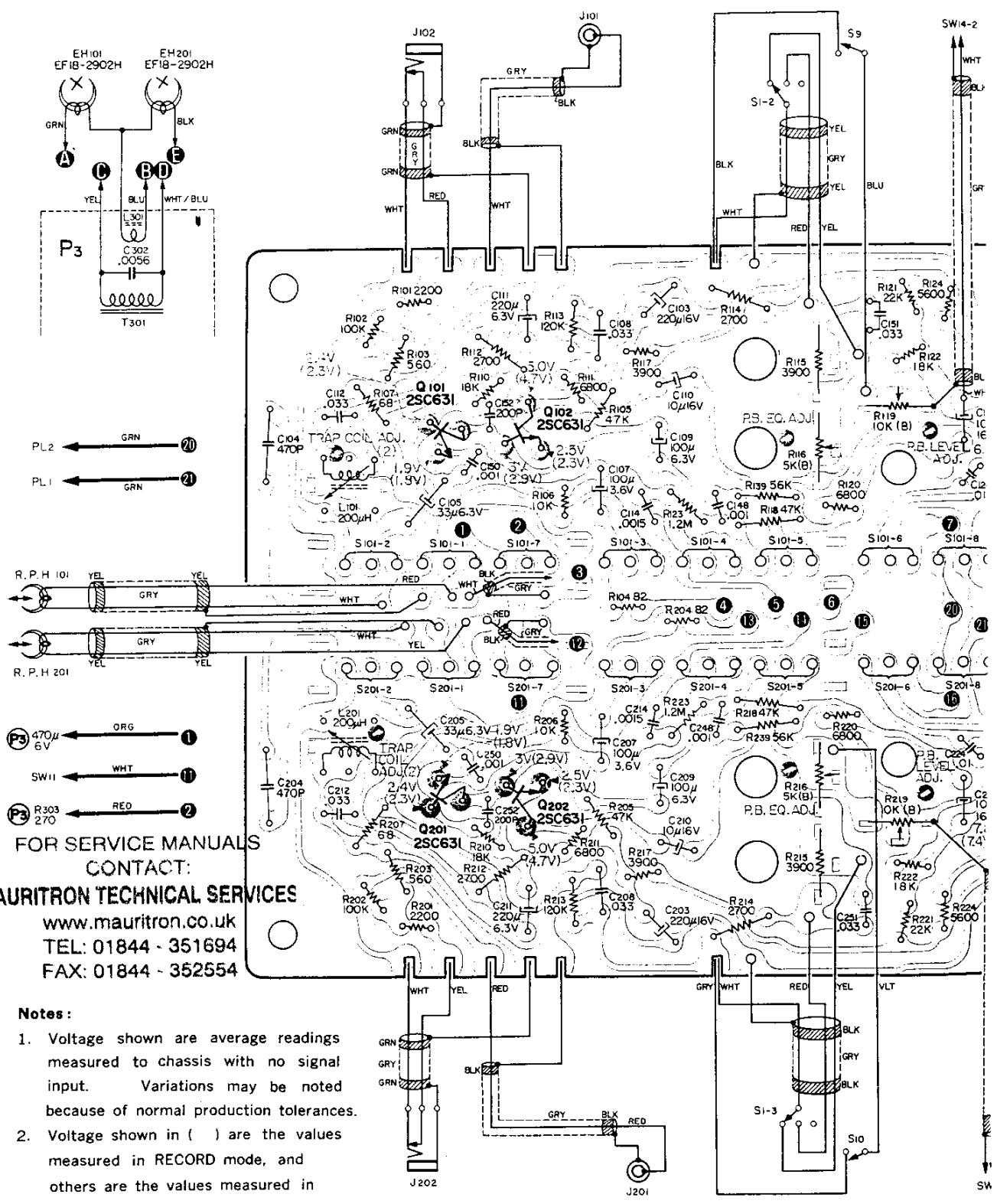

PL2 ← GRN (20)
PL1 ← GRN (2)

R.P.H. 101 YEL GRY YEL
R.P.H. 201 YEL GRY YEL

P3 470μ 6V ← ORG (1)
SW11 ← WHT (1)
P3 R303 270 ← RED (2)

**FOR SERVICE MANUALS
CONTACT:
MAURITRON TECHNICAL SERVICES**
www.mauritron.co.uk
TEL: 01844 - 351694
FAX: 01844 - 352554

- Notes:**
1. Voltage shown are average readings measured to chassis with no signal input. Variations may be noted because of normal production tolerances.
 2. Voltage shown in () are the values measured in RECORD mode, and others are the values measured in PLAYBACK mode.

ction P₁

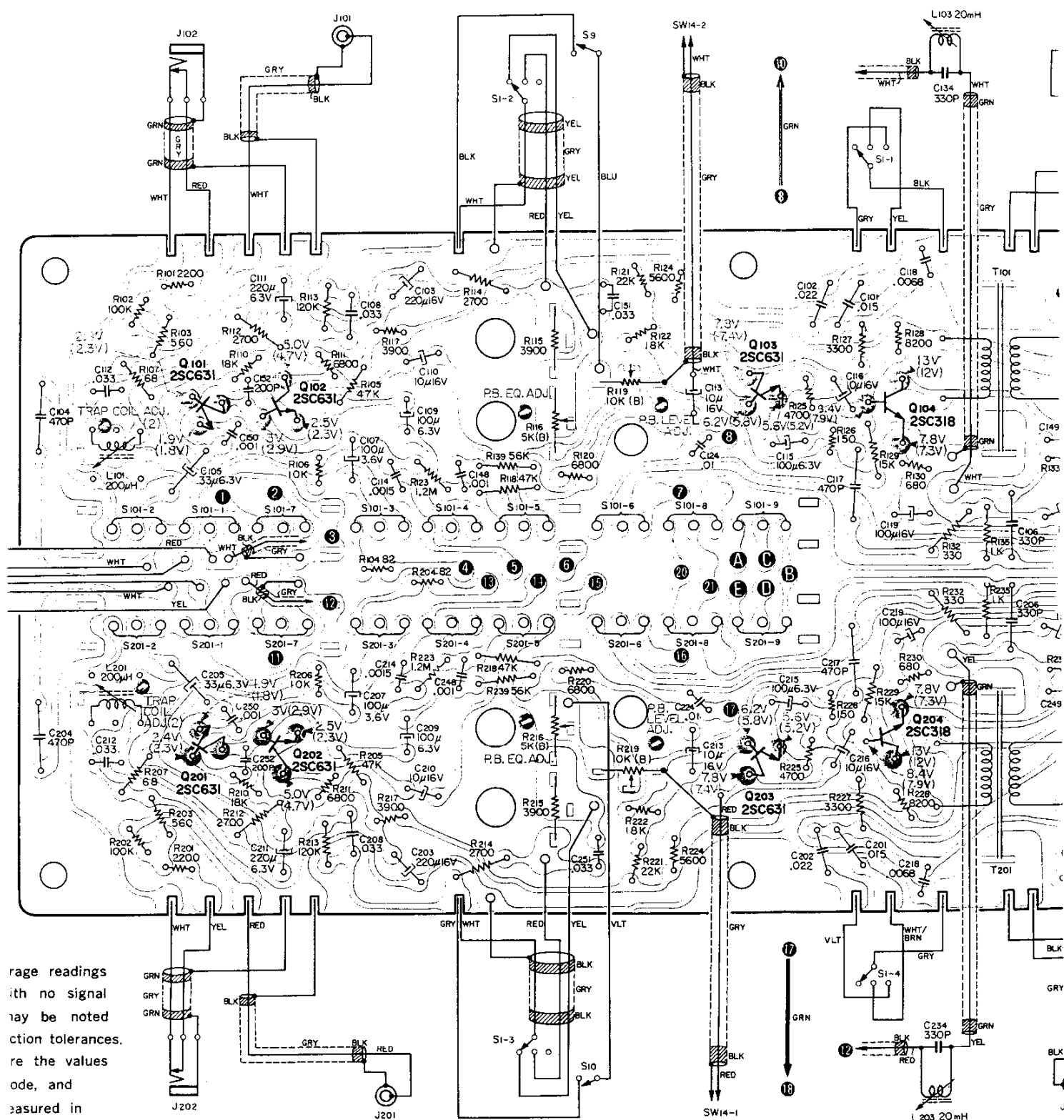

range readings
with no signal
may be noted
attention tolerances.
Use the values
code, and
measured in

FOR SERVICE MANUALS
CONTACT:
MAURITRON TECHNICAL SERVICES

www.mauritron.co.uk
TEL: 01844 351094
FAX: 01844 352554

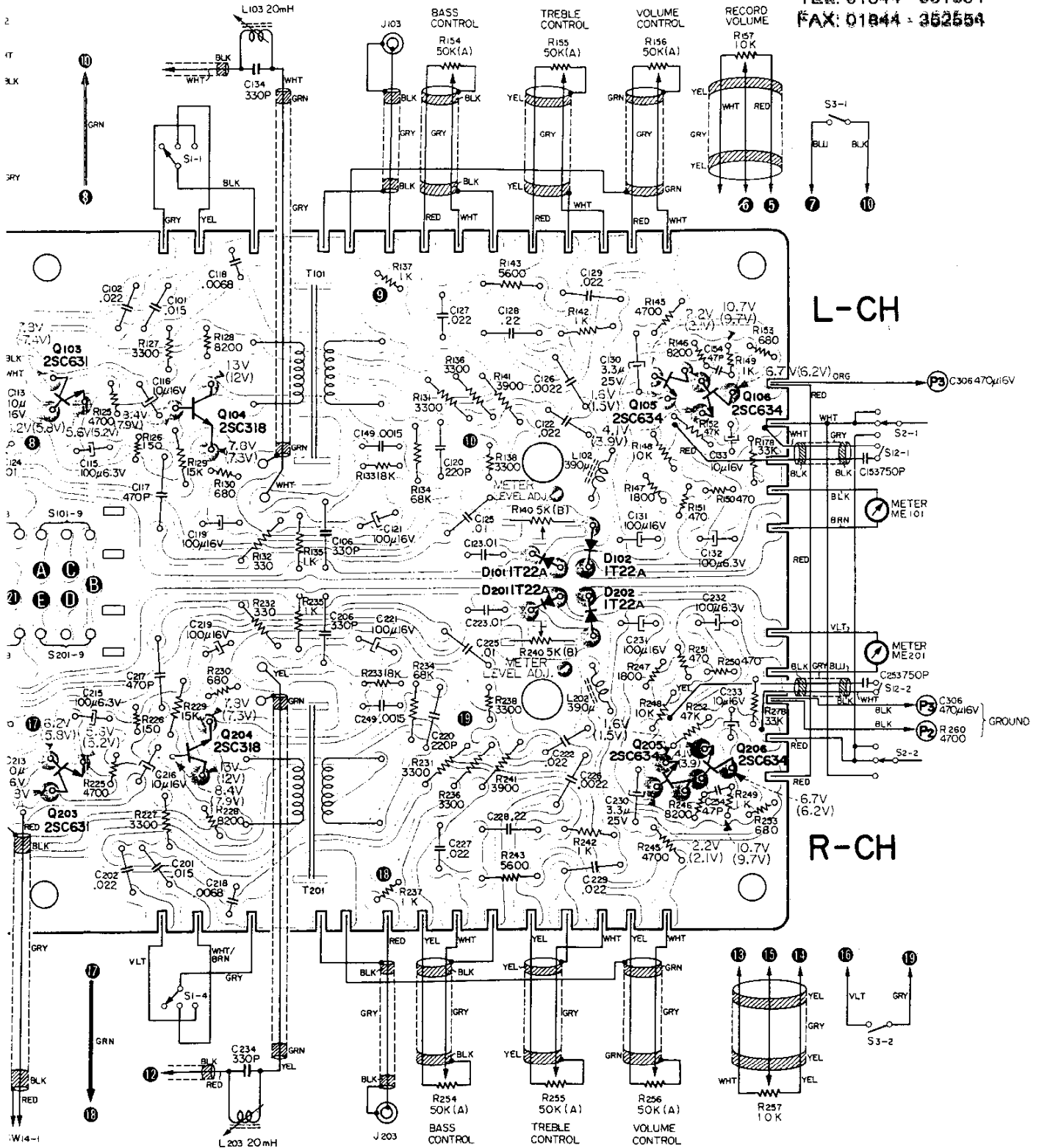

TC-540 TC-540

ion P₁

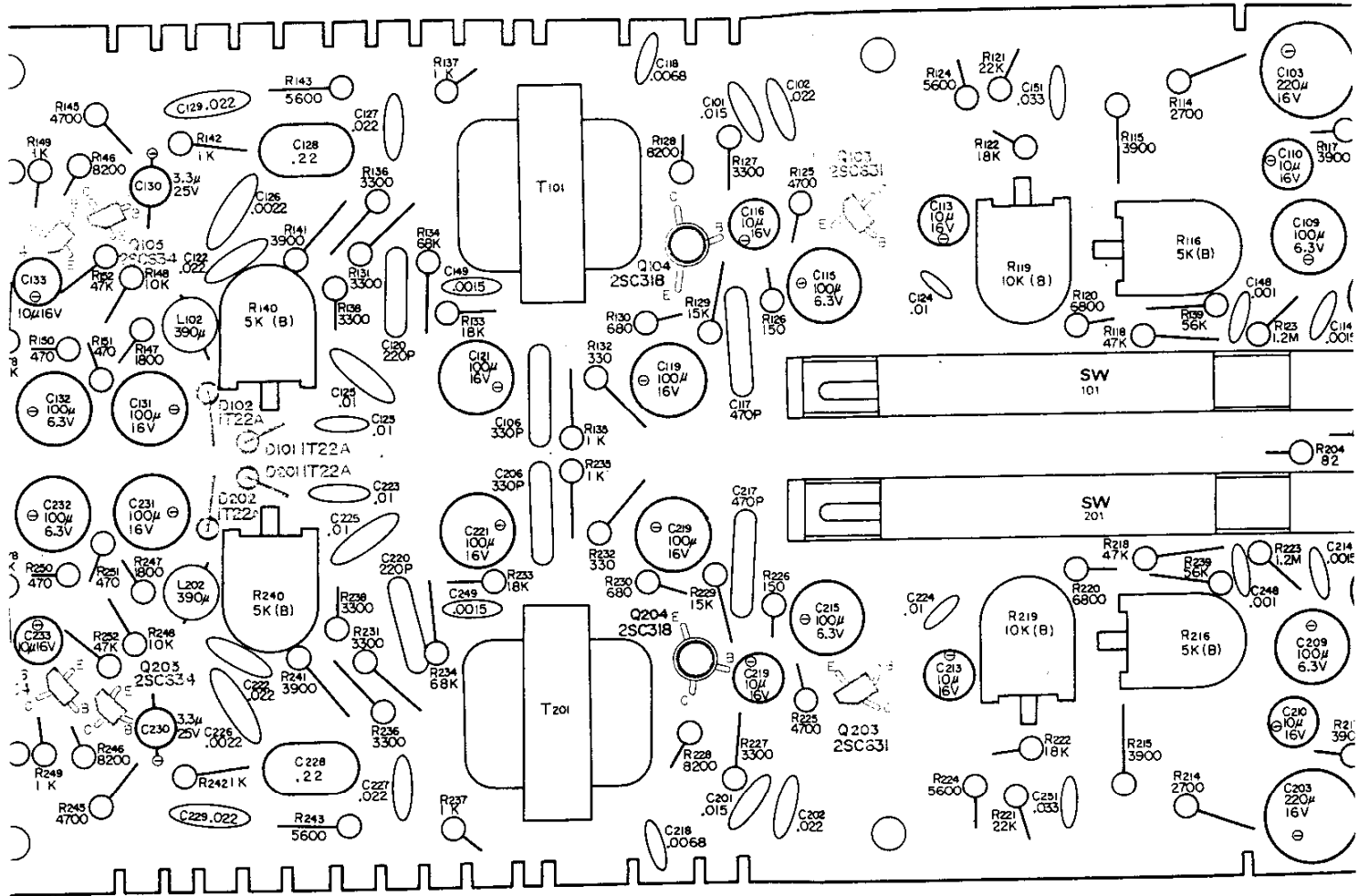

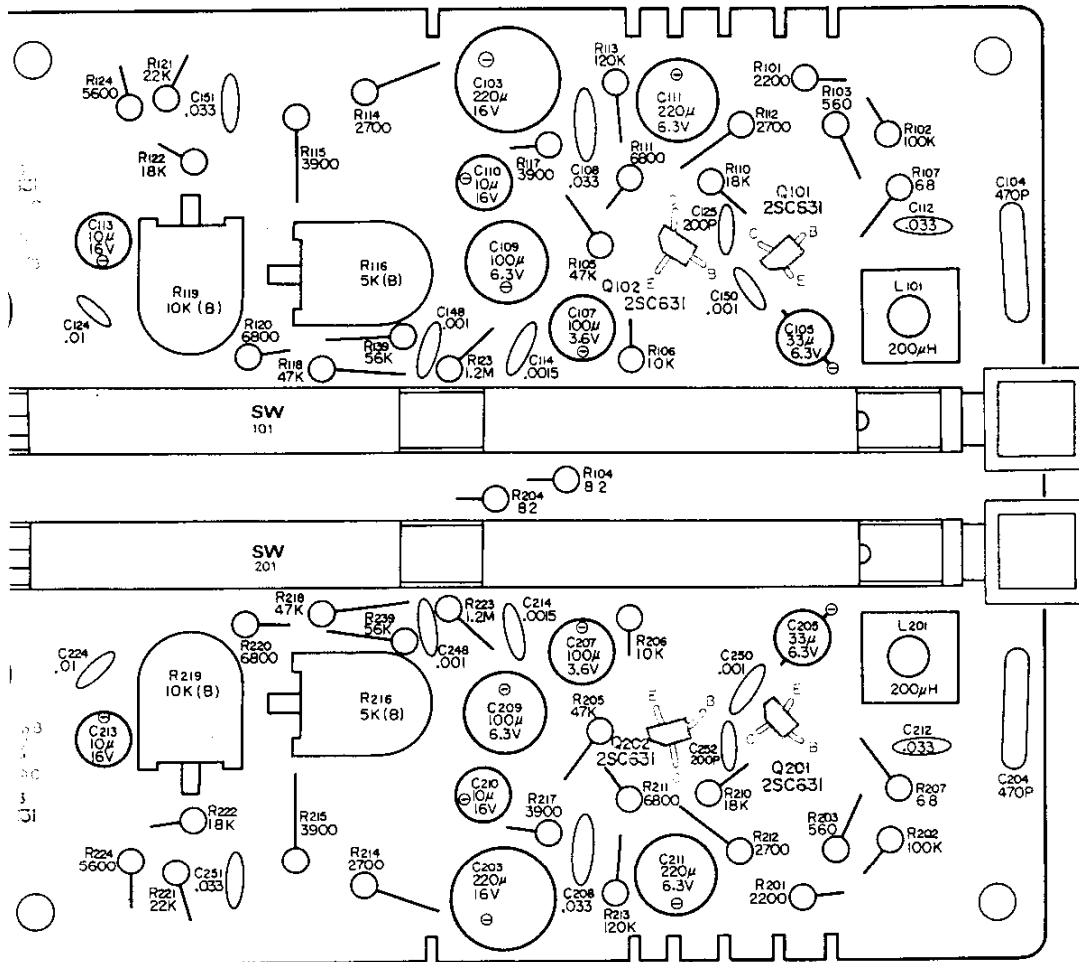

FOR SERVICE MANUALS
 CONTACT:
MAURITRON TECHNICAL SERVICES
 www.mauritron.co.uk
 TEL: 01844 - 351694
 FAX: 01844 - 352554

Mounting Diagram

Power Amplifier Board Section P₂
Conductor Side

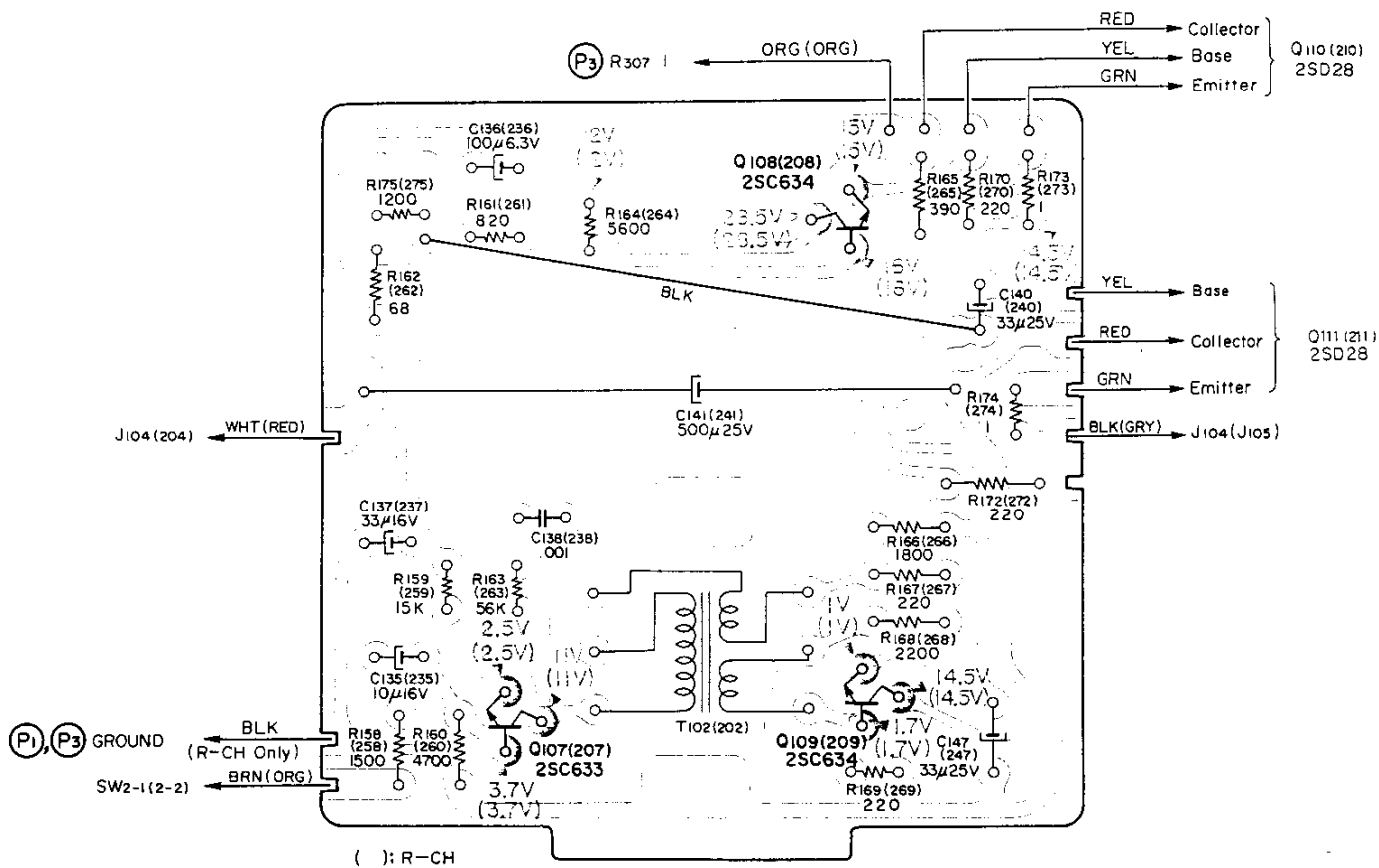

FOR SERVICE MANUALS
CONTACT:
MAURITRON TECHNICAL SERVICES
www.mauritron.co.uk
TEL: 01844 - 351694
FAX: 01844 - 352554

Notes:

1. Voltages shown are average readings measured to chassis with no signal input. Variations may be noted because of normal production tolerances.
2. Voltage shown in () are the values measured in RECORD mode, and others are the values measured in PLAYBACK mode.

Mounting Diagram

Power Amplifier Board Section P,
- Component Side

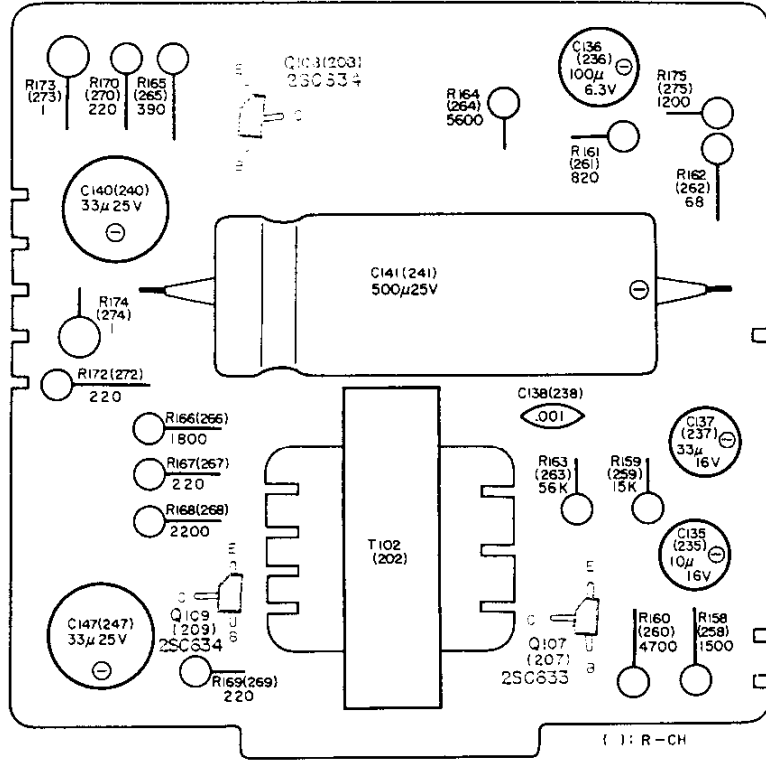

FOR SERVICE MANUALS
CONTACT:
MAURITRON TECHNICAL SERVICES
www.mauritron.co.uk
TEL: 01844 - 351694
FAX: 01844 - 352554

Mounting Diagram

Power Supply & Bias OSC Board Section P₃
 (See Motor Side)

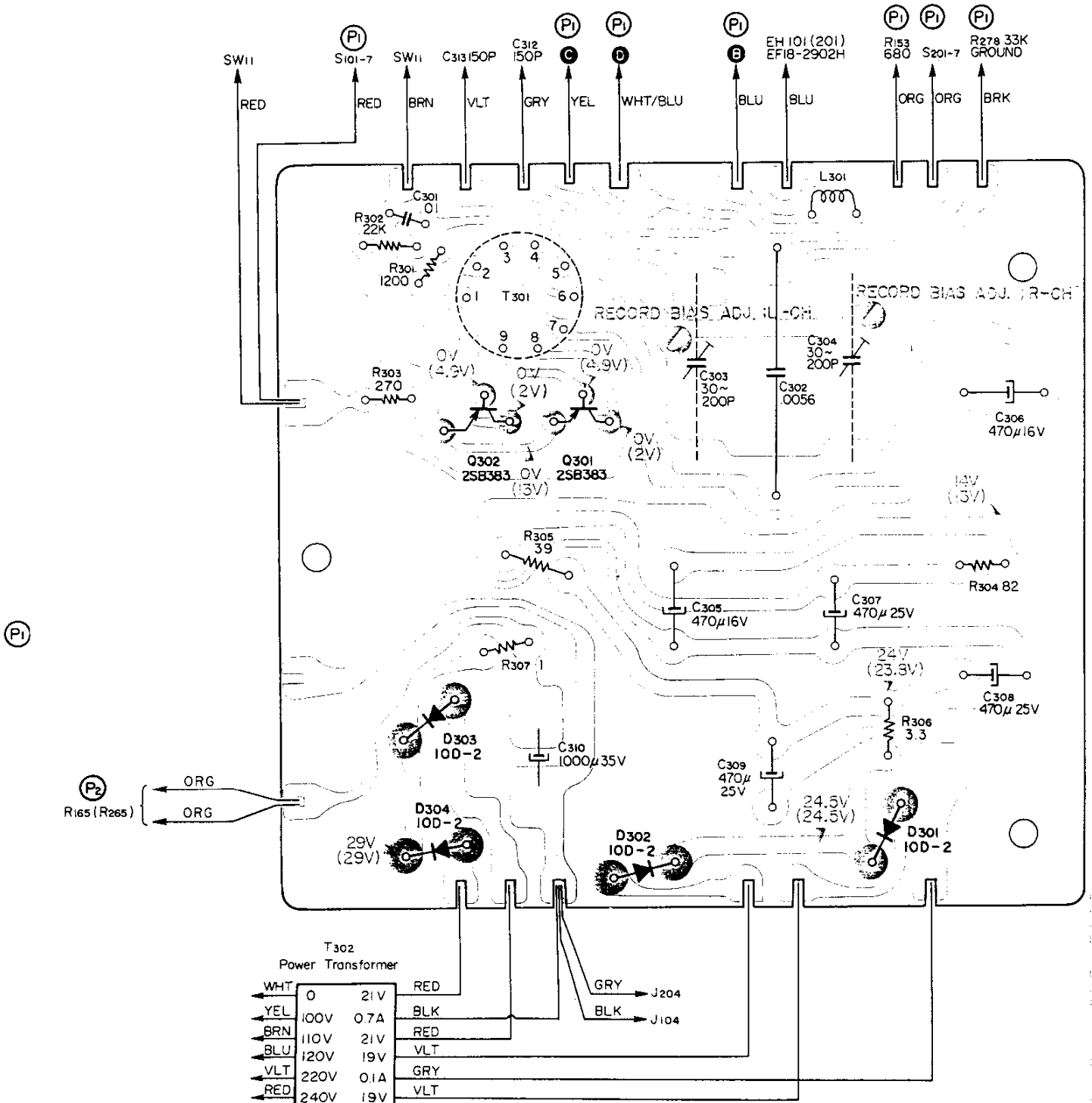

Mounting Diagram

Power Supply & Bias OSC Board Section P₃
Component Side

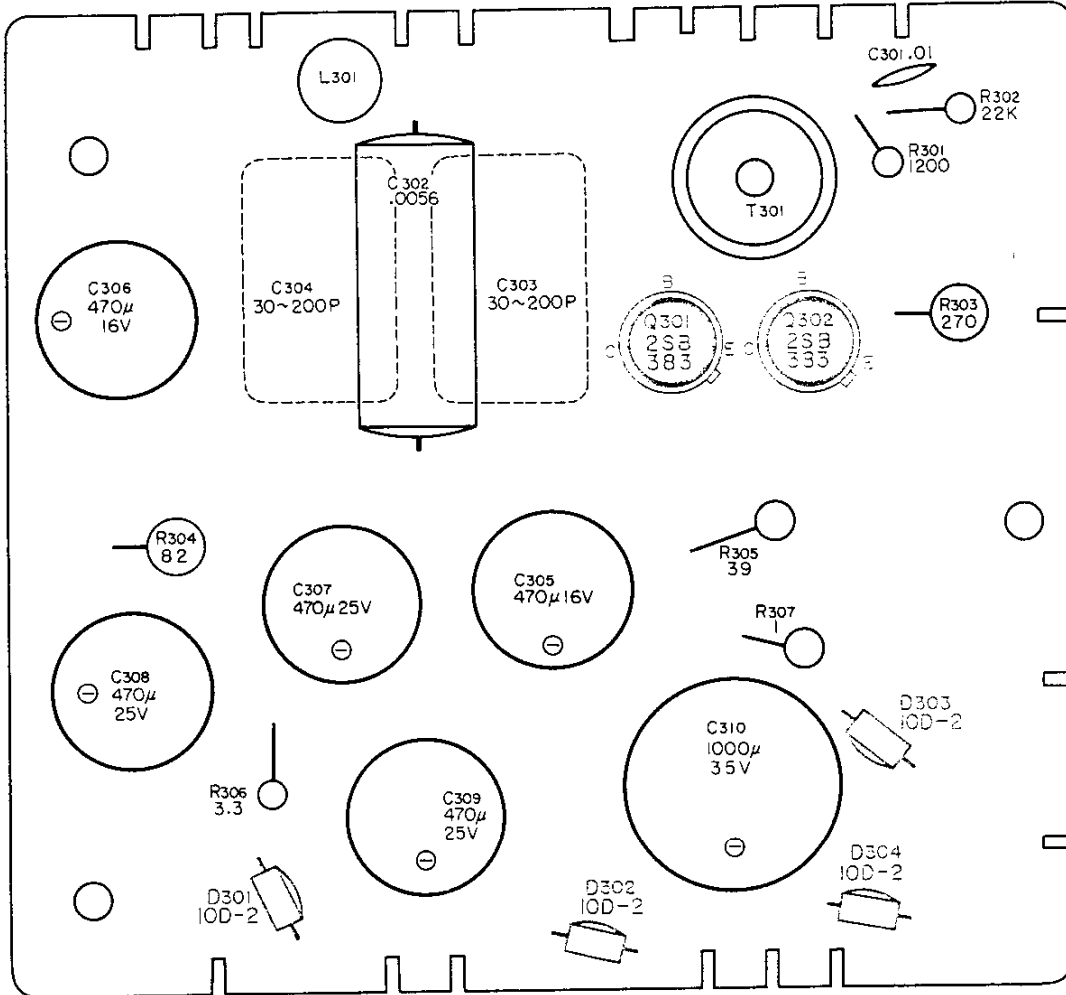

FOR SERVICE MANUALS
CONTACT:
MAURITRON TECHNICAL SERVICES
www.mauritron.co.uk
TEL: 01844 - 351694
FAX: 01844 - 352554

Mounting Diagram

Speaker Circuit Board Section P.
Conductor Side

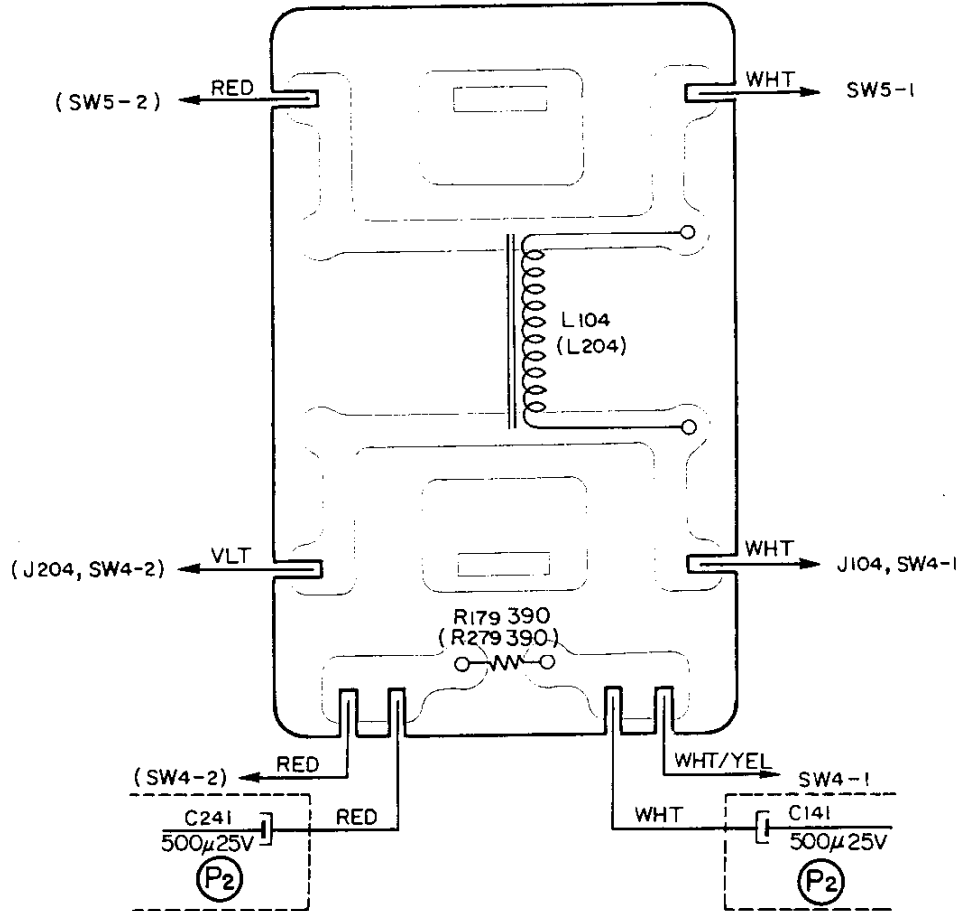

() ; R-CH - Component Side -

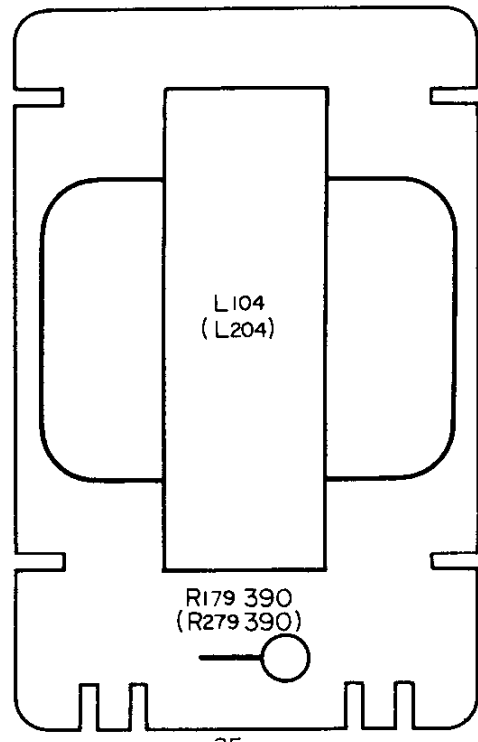

Mounting Diagram

SOUND-ON-SOUND Board Section P,
Conductor Side ---

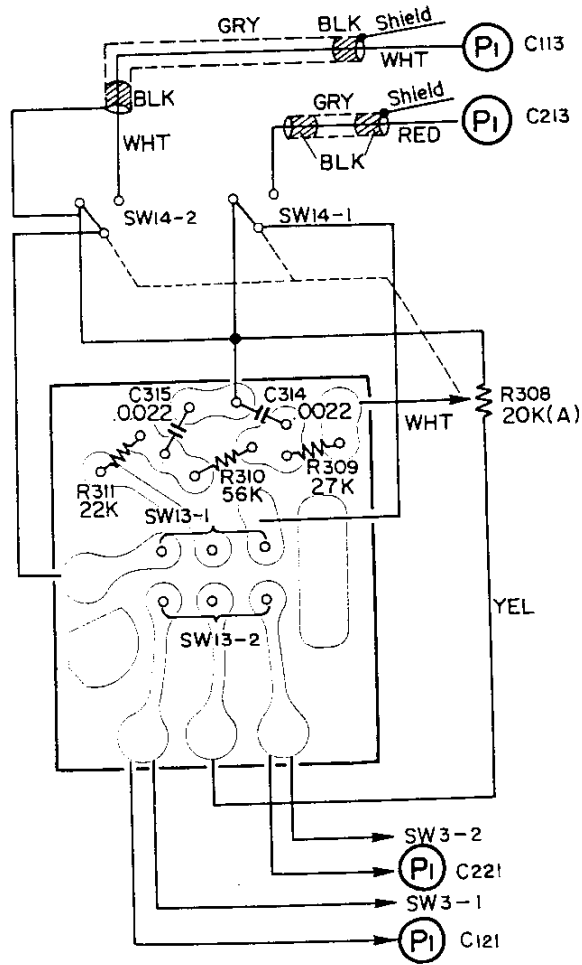

— Component Side —

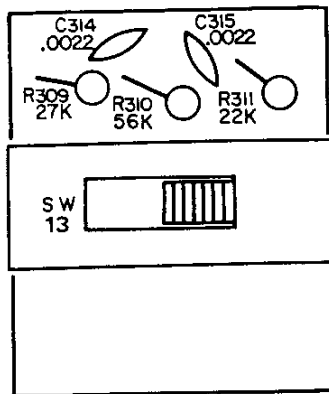

FOR SERVICE MANUALS
CONTACT:
MAURITRON TECHNICAL SERVICES
www.mauritron.co.uk
TEL: 01844 - 351694
FAX: 01844 - 352554

Exploded Diagram

Tape Transport Mechanism—Top View

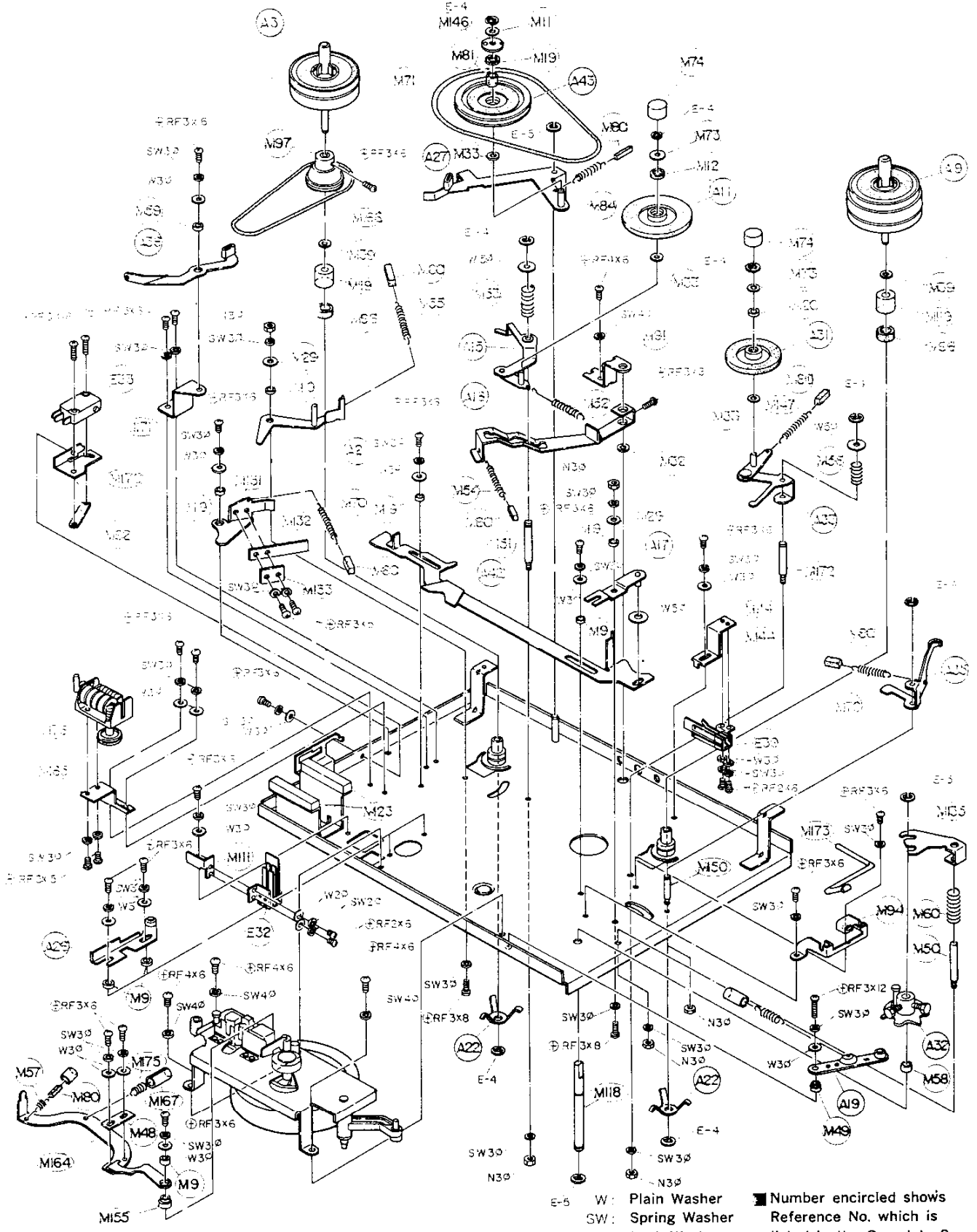

- E-5 W: Plain Washer
 - SW: Spring Washer
 - LW: Lock Washer
 - N: Nut
 - E: Retaining Ring
- Number encircled shows Reference No. which is listed in the Complete Spare Parts List attached hereto.

Exploded Diagram

Head Deck—Top View

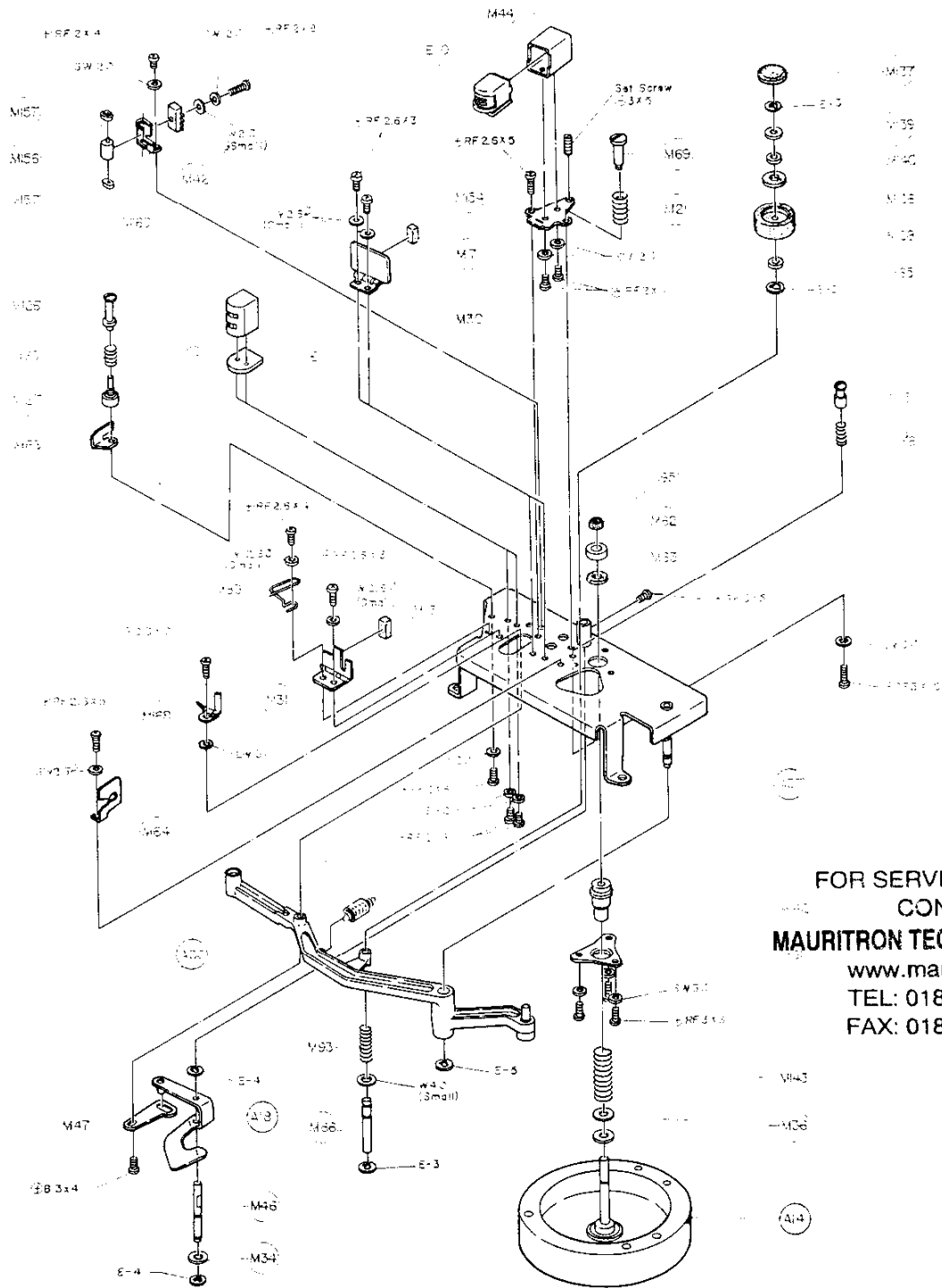

FOR SERVICE MANUALS
 CONTACT:
MAURITRON TECHNICAL SERVICES
 www.mauritron.co.uk
 TEL: 01844 - 351694
 FAX: 01844 - 352554

- W: Plain Washer
 - SW: Spring Washer
 - LW: Lock Washer
 - N: Nut
 - E: Retaining Ring
- Number encircled shows Reference No. which is listed in the Complete Spare Parts List attached hereto.

Exploded Diagram

Chassis— Bottom View

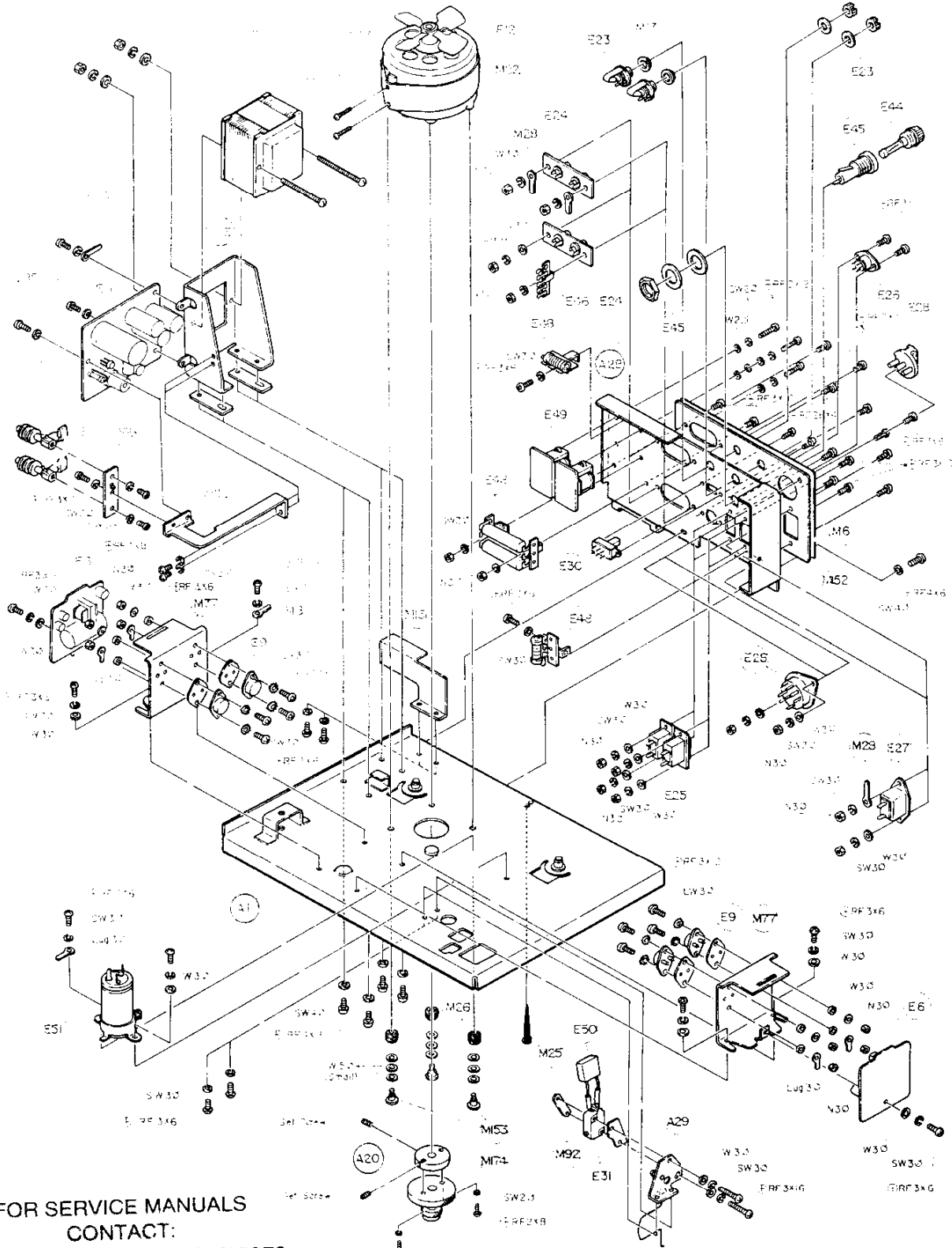

FOR SERVICE MANUALS
CONTACT:
MAURITRON TECHNICAL SERVICES
www.mauritron.co.uk
TEL: 01844 - 351694
FAX: 01844 - 352554

- W: Plain Washer
 - SW: Spring Washer
 - LW: Lock Washer
 - N: Nut
 - E: Retaining Ring
- Number encircled shows Reference No. which is listed in the Complete Spare Parts List attached hereto.

Exploded Diagram

Front & Side Chassis—Top View

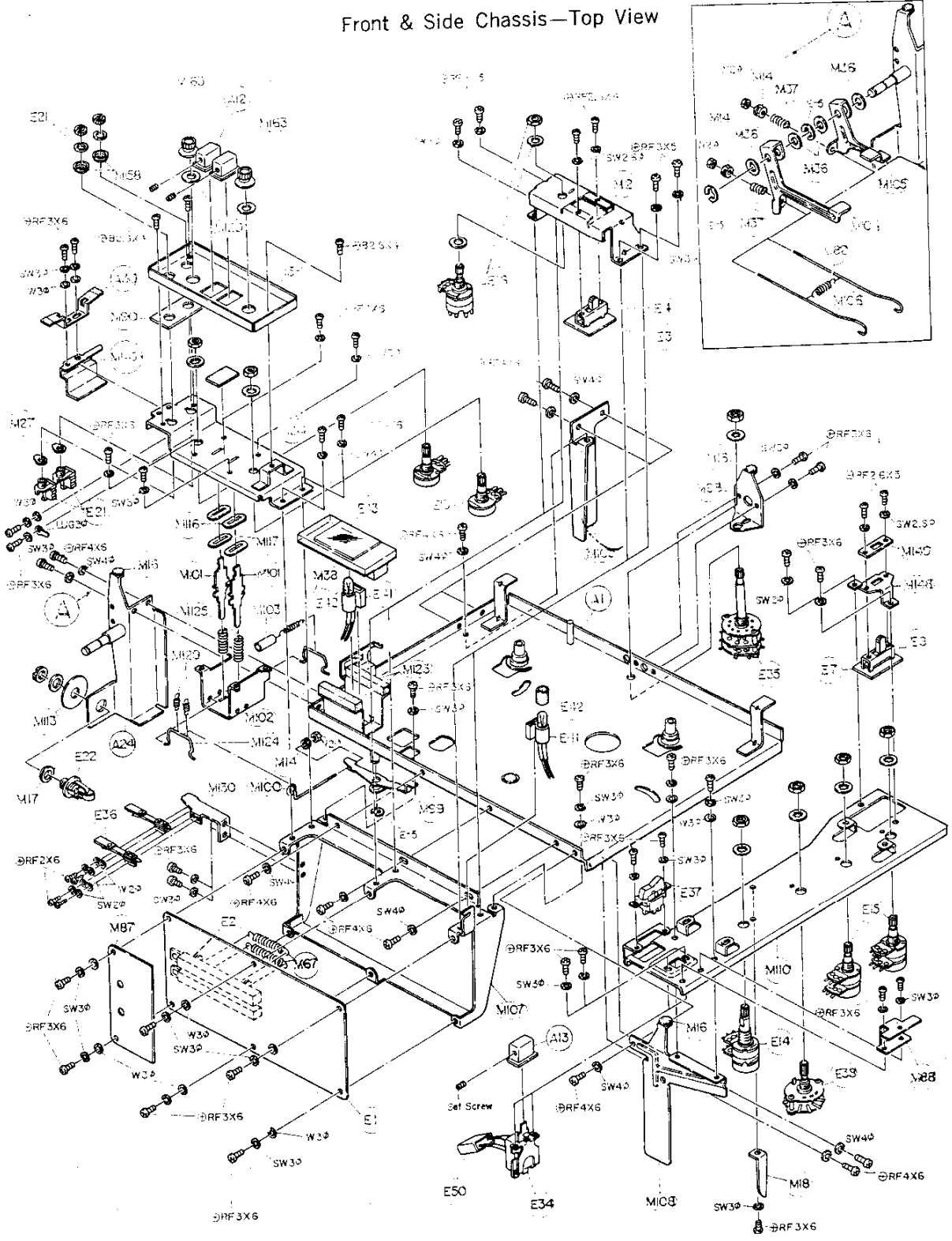

FOR SERVICE MANUALS
CONTACT:
MAURITRON TECHNICAL SERVICES
www.mauritron.co.uk
TEL: 01844 - 351694
FAX: 01844 - 352554

- W: Plain Washer
 - SW: Spring Washer
 - LW: Lock Washer
 - N: Nut
 - E: Retaining Ring
- Number encircled shows Reference No. which is listed in the Complete Spare Parts List attached hereto.

Exploded Diagram

Lid Speakers—Top View

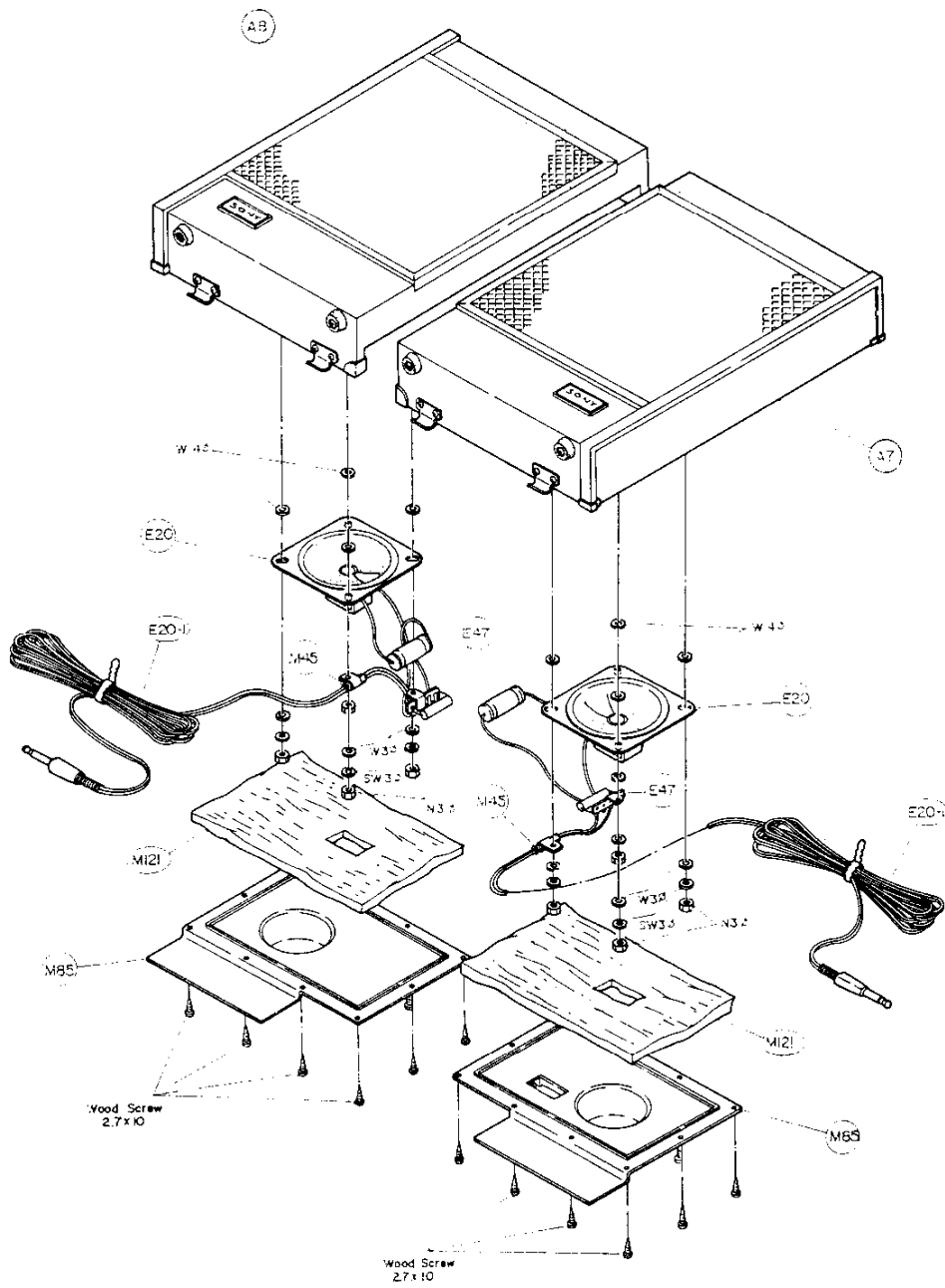

- W : Plain Washer
 - SW : Spring Washer
 - LW : Lock Washer
 - N : Nut
 - E : Retaining Ring
- Number encircled shows Reference No. which is listed in the Complete Spare Parts List attached hereto.

Exploded Diagram

Entire—Top View

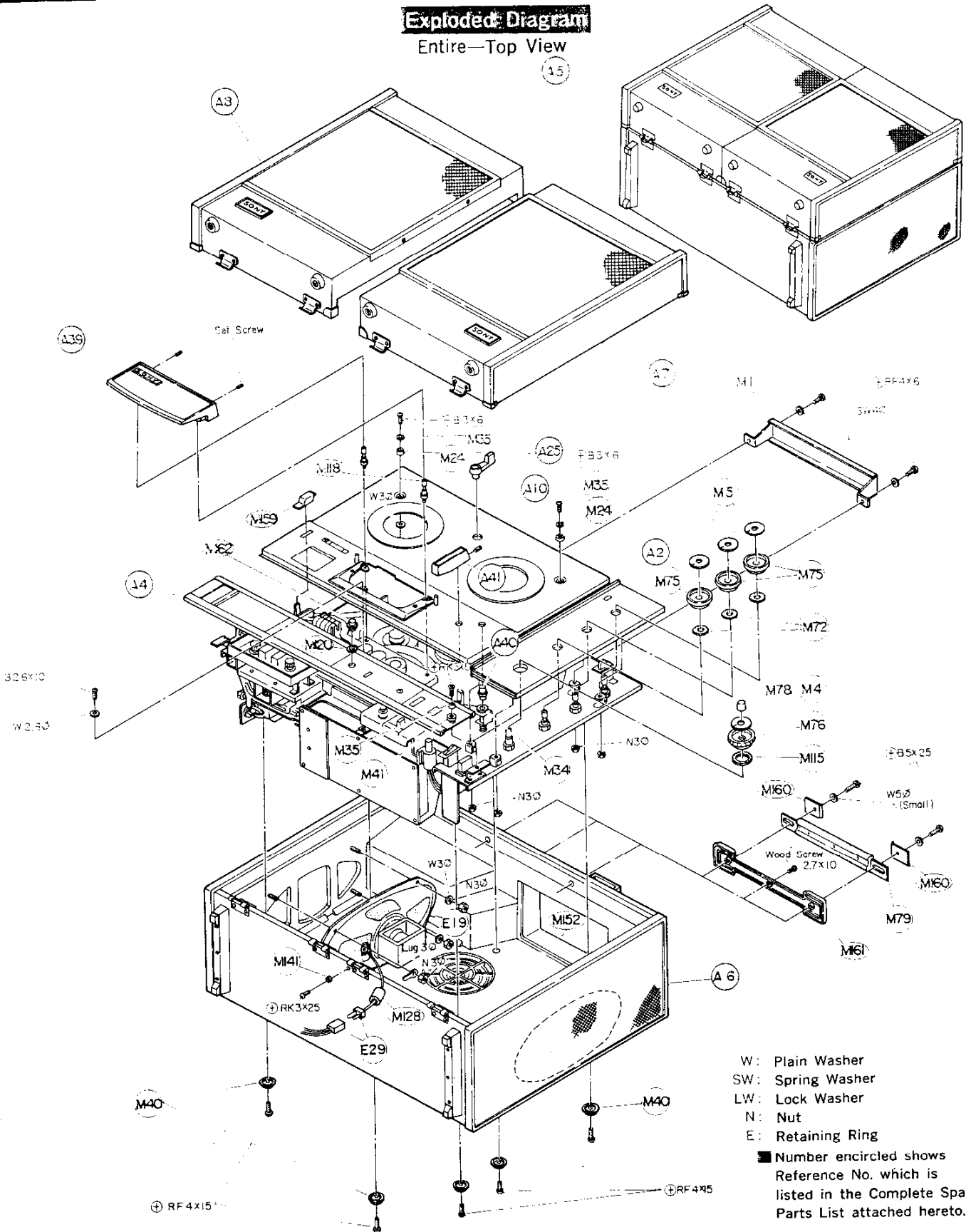

- W: Plain Washer
- SW: Spring Washer
- LW: Lock Washer
- N: Nut
- E: Retaining Ring

Number encircled shows Reference No. which is listed in the Complete Spare Parts List attached hereto.

SONY CORPORATION

TC-540 Schematic Diagram

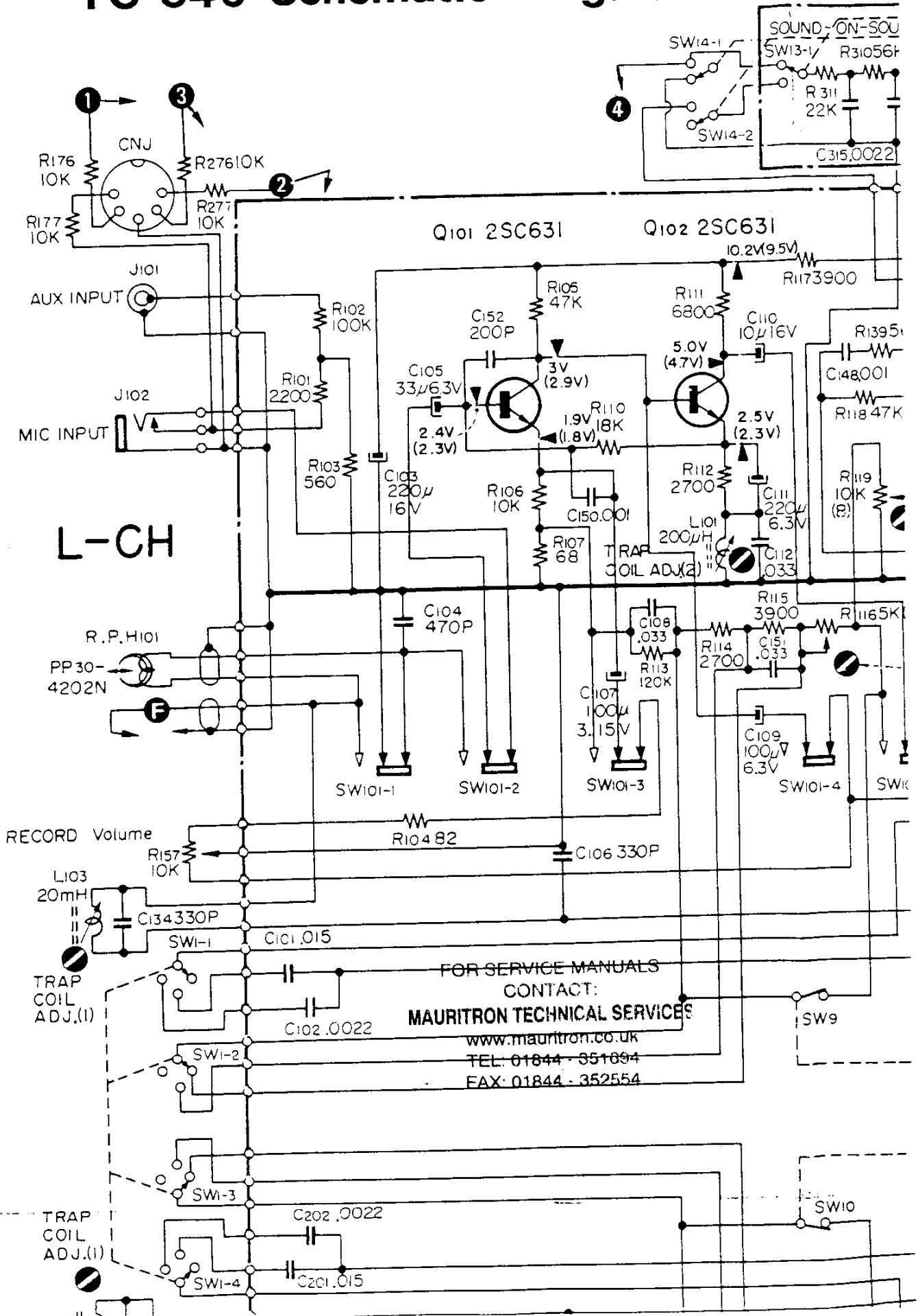

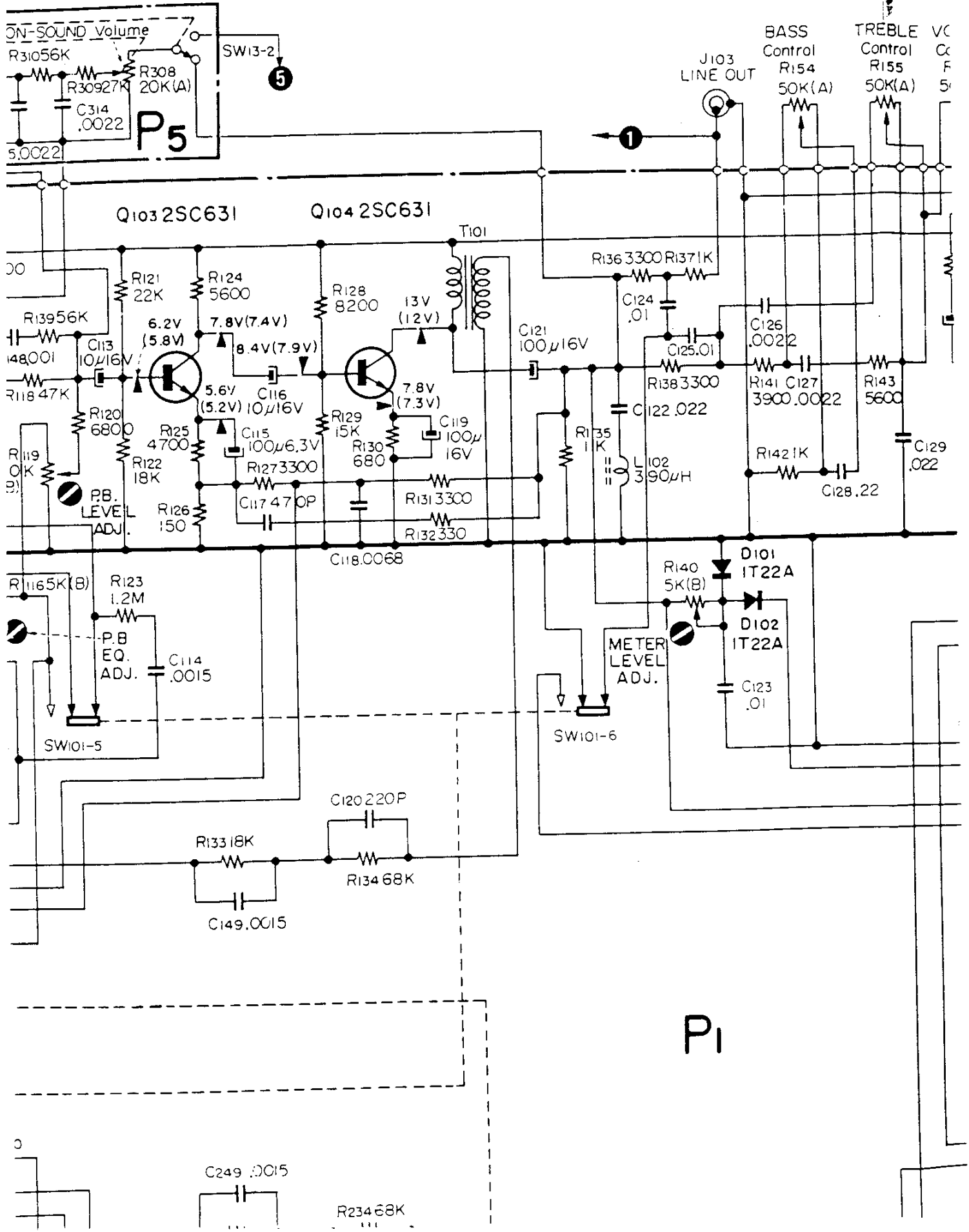

BLE VOLUME
 ntral Control
 '155 R156
 K(A) 50K(A)

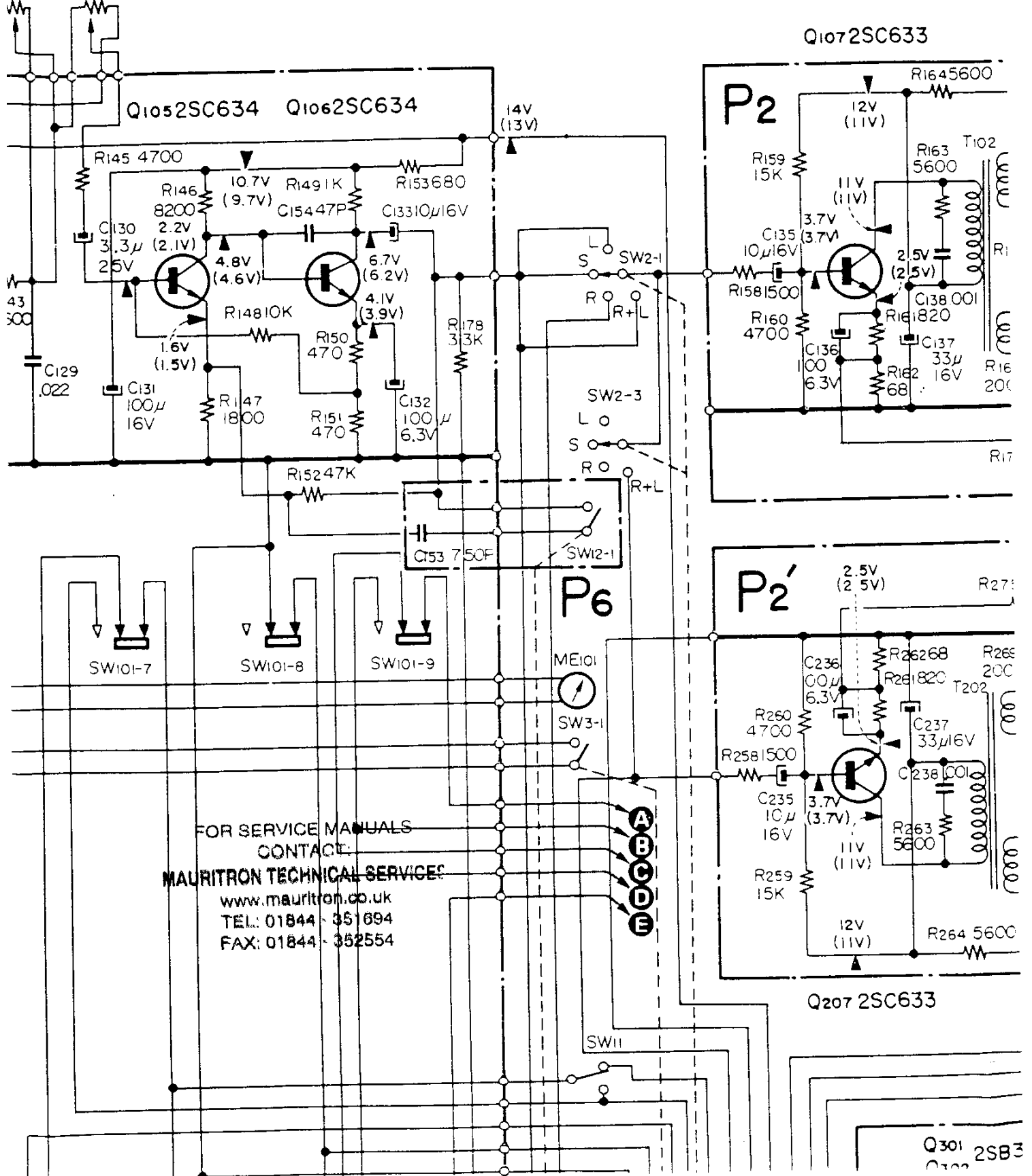

FOR SERVICE MANUALS
 CONTACT:
MAURITRON TECHNICAL SERVICES
 www.mauritron.co.uk
 TEL: 01844 - 351694
 FAX: 01844 - 352554

A
 B
 C
 D
 E

Q301 2SB3
 Q102 2SC633

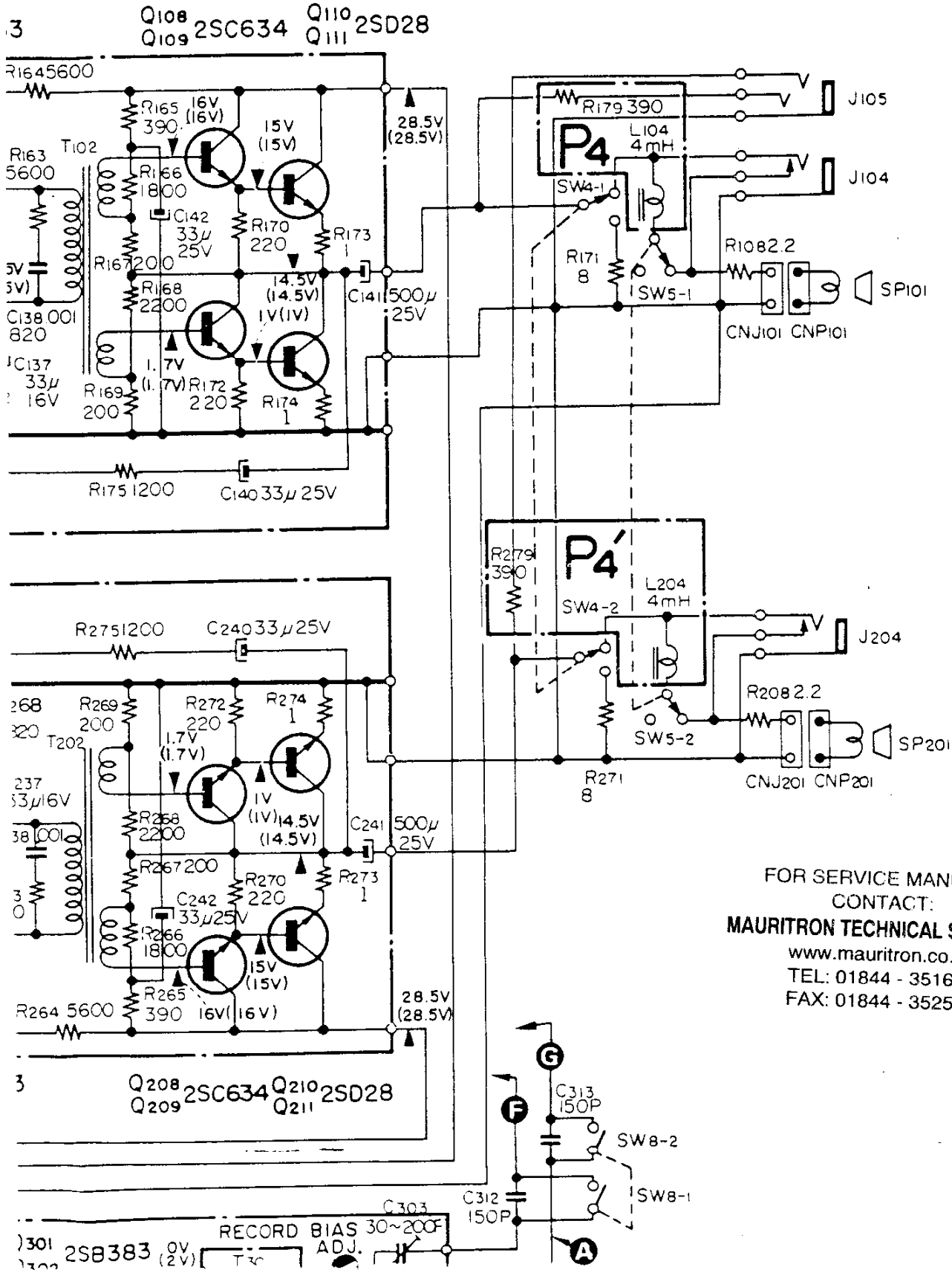

FOR SERVICE MANUALS
CONTACT:
MAURITRON TECHNICAL SERVICES

www.mauritron.co.uk
TEL: 01844 - 351694
FAX: 01844 - 352554

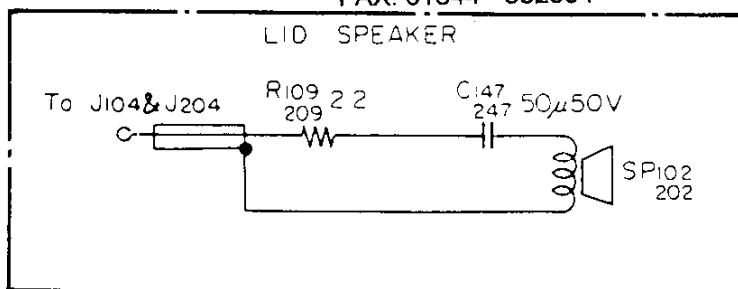
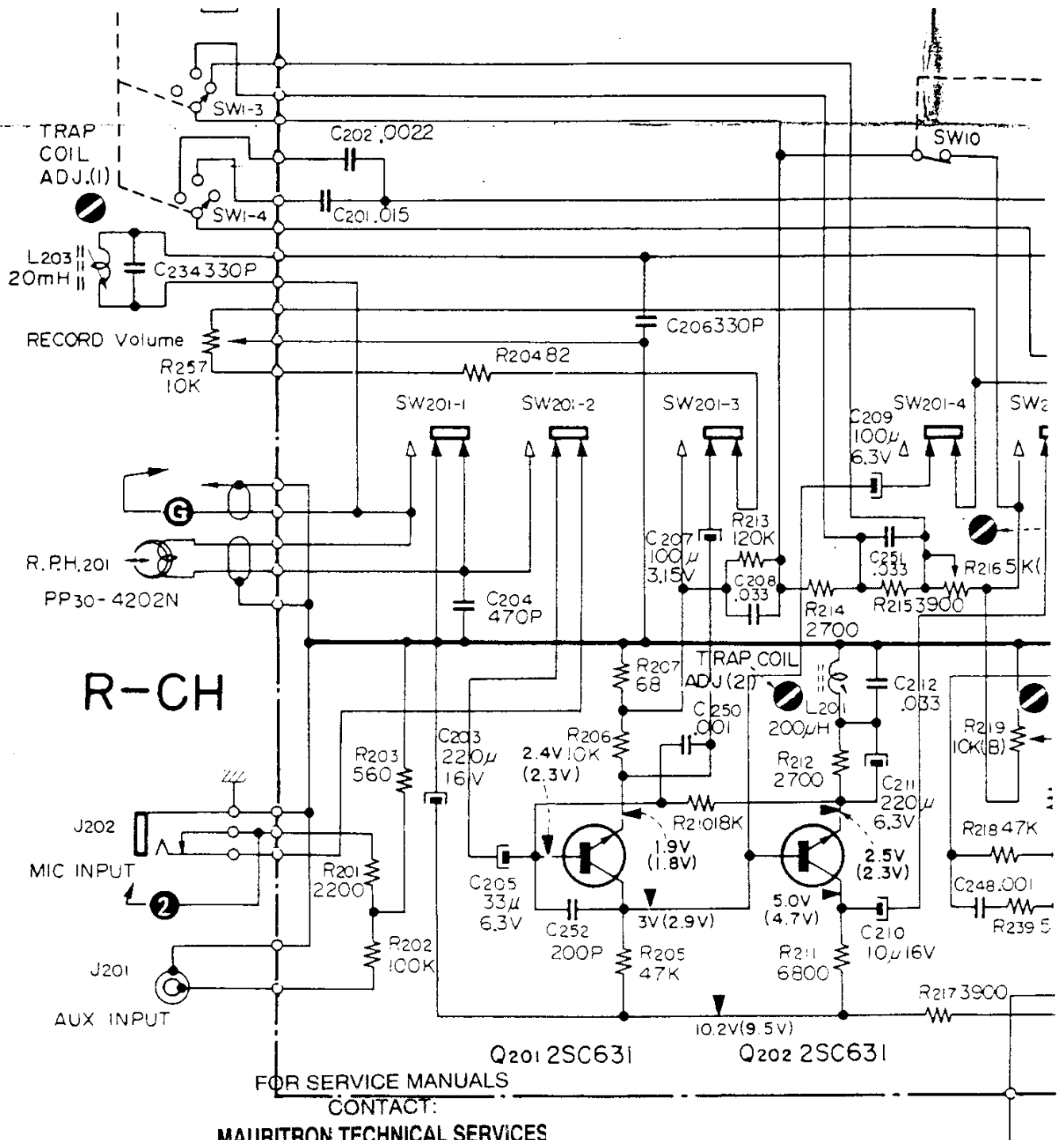

Notes:

1. Switch Positions shown thi

Switch No.	Desc
SW _{101, 120}	Record/Playback
SW ₁	Equalizer Switch
SW ₂	Speaker Mode
SW ₃	Muting Switch
SW ₄	Speaker ON/OFF
SW ₅	EXT-LID Speaker
SW ₆	Automatic SHU

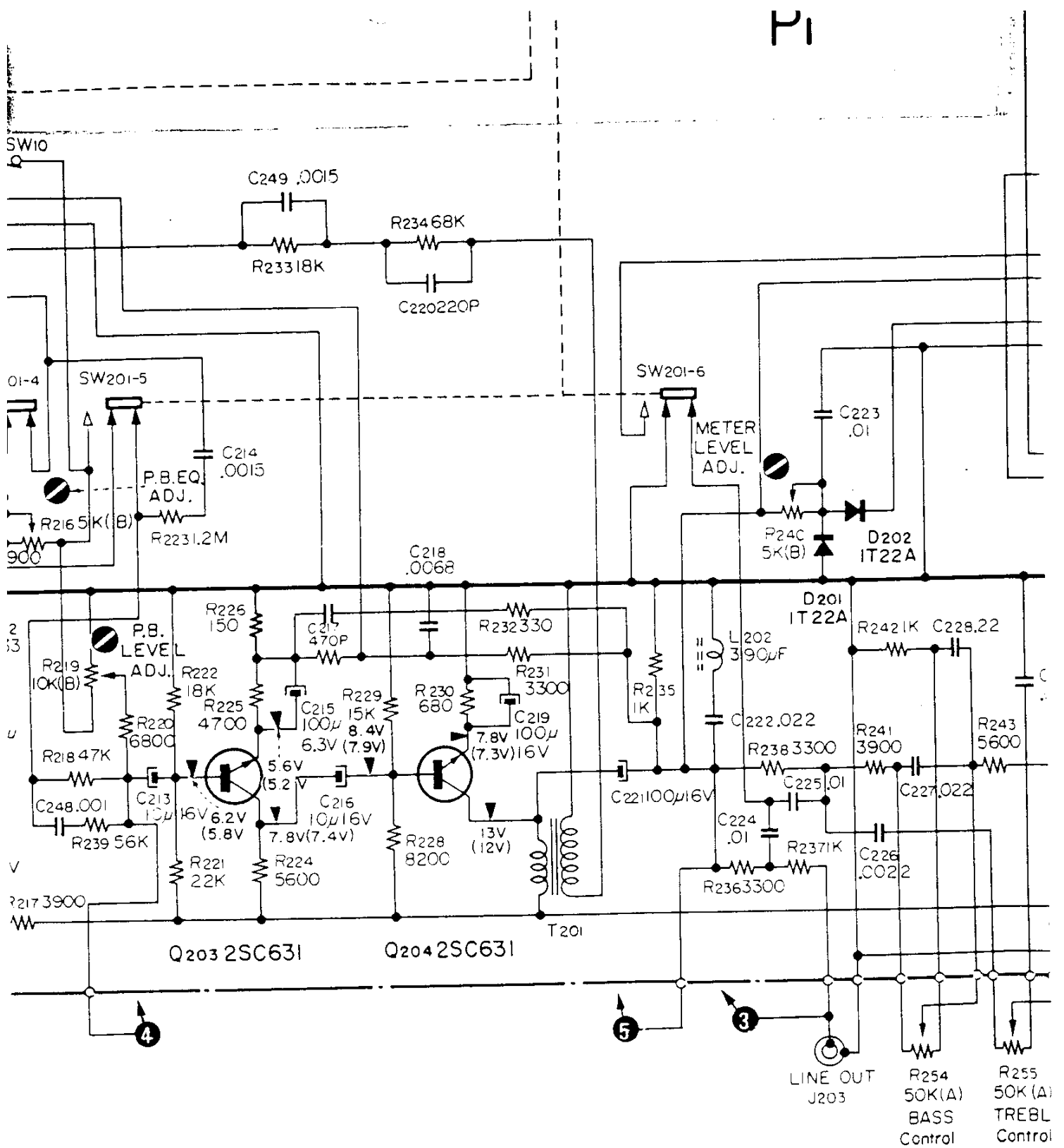

As shown in this diagram are as per the table below.

Description	Position
Record/Playback Switch	Record
Equalizer Switch	7 1/2 ips (19 cm/s)
Speaker Mode Switch	Stereo
Muting Switch	OFF
Speaker ON OFF Switch	ON
TELEVISION Speaker Change Switch	ON
Automatic SHUT-OFF Switch	OFF

Switch No.	Description
SW ₁	Power ON/OFF Switch
SW ₂	Bias Control Switch
SW _{3, 4, 5}	Monaural Record Switch
SW ₆	Bias ON/OFF Switch
SW ₇	Noise Suppressor ON/OFF Switch
SW ₈	SOUND-ON-SOUND Channel Select
SW ₉	SOUND-ON-SOUND Defeat Switch

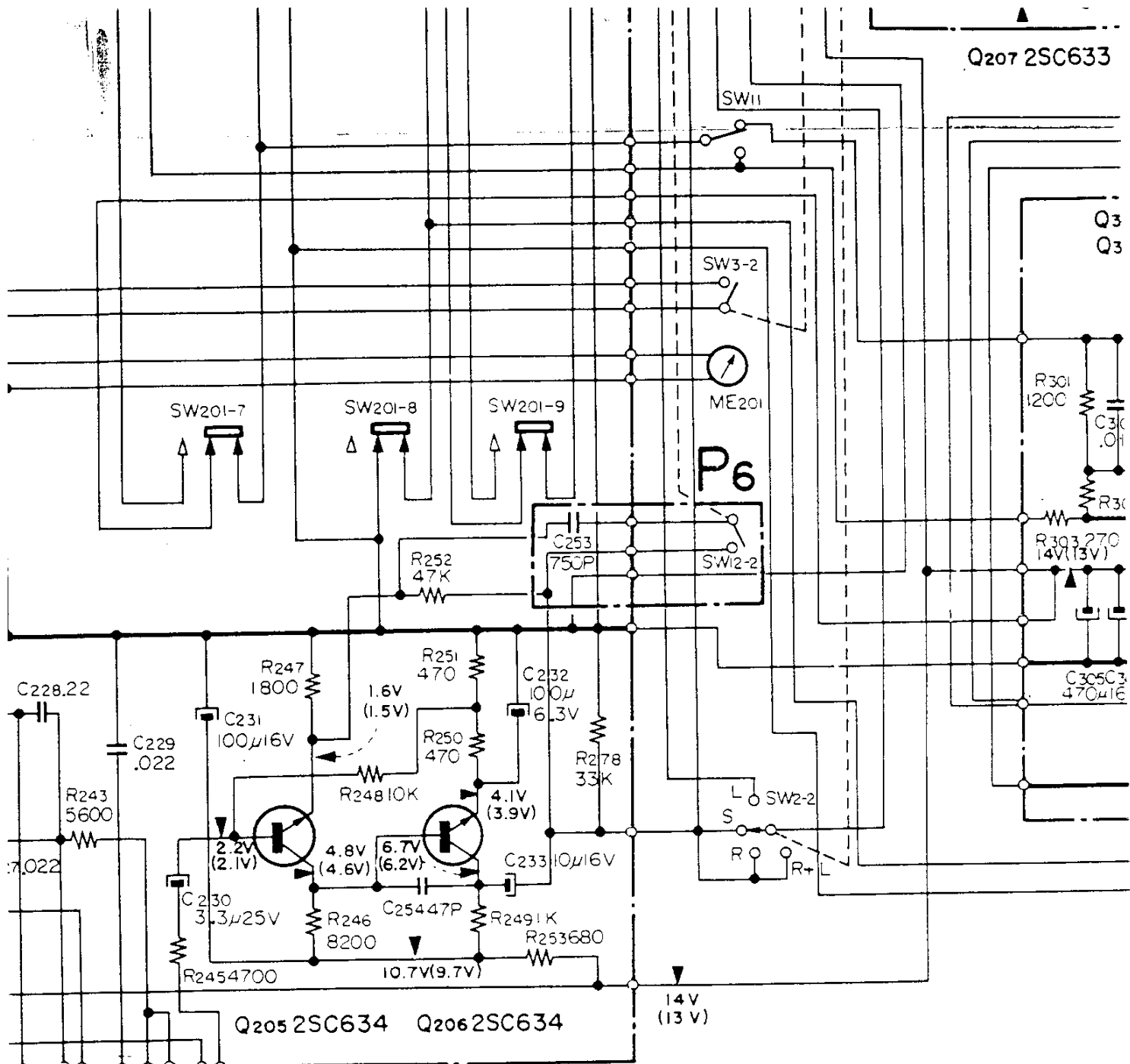

54 R255 R256
 <(A) 50K (A) 50K(A)
 .SS TREBLE VOLUME
 trol Control Control

FOR SERVICE MANUALS
 CONTACT:
MAURITRON TECHNICAL SERVICES
 www.mauritron.co.uk
 TEL: 01844 - 351694
 FAX: 01844 - 352554

2. : Adjustable
3. : Grounding to chassis
4. All resistors and capacitance values are in Ohms unless otherwise stated.
5. The letter (A) or (B) suffix indicates a tolerance of 5%.
6. All the voltage values shown are in Volts DC unless otherwise stated. Voltage values in RECORD mode with no signal input. Voltage values in RECALL mode with no signal input. Variation may be noted.
7. P₁: Pre-Amplifier Circuit
 P₂: Power Amplifier Circuit
 P₃: Power Supply & Biasing
 P₄: Speaker Circuit Board
 P₅: SOUND-ON-SOUND (SOS)
 P₆: Noise Suppressor Switch

Description	Position
1	OFF OFF (1 7/8 ips, 4.8 cm/s) ON (3 3/4 ips, 9.5 cm/s) & (7 1/2 ips, 19 cm/s)
2	ON
3	FORWARD
4	OFF
5	L-CH-R-CH
6	OFF

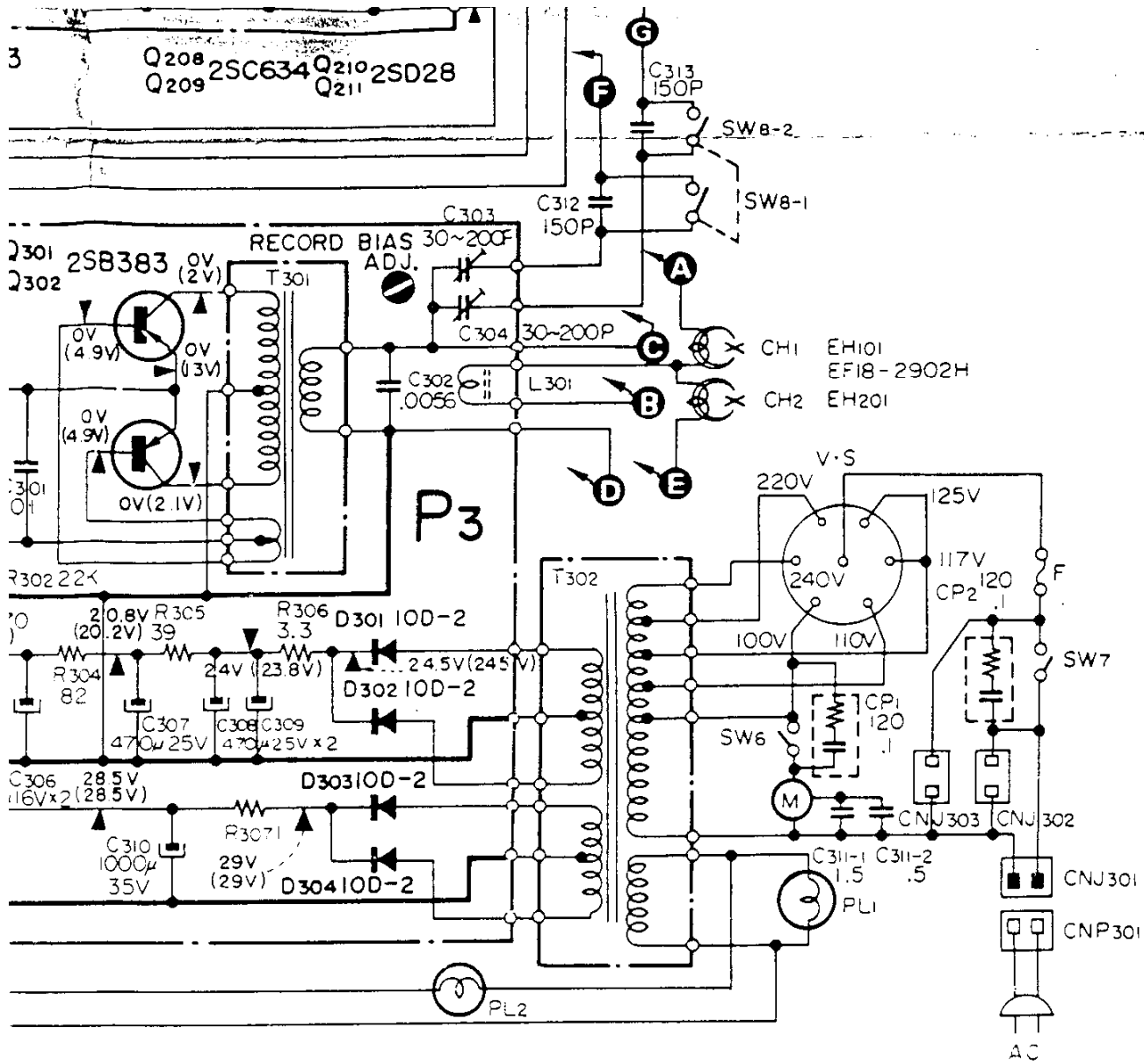

assis

itors are in ohm and μF , unless otherwise specified.

uffixed to rating value of potentiometer indicates its characteristic.

shown in color are DC unless otherwise noted and measured in PLAYBACK

input by using VTVM.

ORD mode enclosed in parentheses.

d because of normal production tolerance.

uit Board.

ircuit Board.

ias OSC Circuit Board.

oard.

ircuit Board.

Switch Circuit Board.

Complete Spare Parts List for TC-540 (E)

July, 1968

<u>Ref. No.</u>	<u>Part No.</u>	<u>Description</u>	<u>Unit Price</u>
I. Mechanical Parts			
A1	X-34496-01	Base Plate Ass'y -----	
A2	-03	Control Panel Ass'y -----	
A3	-04	Table Ass'y, feed reel -----	
A4	-05	Sash Ass'y, front part -----	
A5	-08	Complete Cabinet Ass'y -----	
A6	-11	Cabinet Ass'y -----	
A7	-12	Cabinet Lid Ass'y, right -----	
A8	-13	" " " , left -----	
A9	-09	Table Ass'y, take-up reel -----	
A10	-10	Reel Panel Ass'y -----	
A11	X-00270-03	Idler (A) Ass'y; capstan -----	
A12	X-34130-11	Button (A) Ass'y, record -----	
A13	-12	" (B) " , power ON/OFF switch -----	
A14	X-34180-04	Flywheel Ass'y, capstan -----	
A15	-06	Idler Arm (A) Ass'y -----	
A16	-08	Lever Ass'y, speed selector -----	
A17	-14	Lever Ass'y, joint -----	
A18	-27	Lever, pinch roller shifter -----	
A19	-30	Stepper Arm Ass'y -----	
A20	-33	Bracket Ass'y, motor pulley -----	
A21	X-34300-02	Lever Ass'y, capstan idler release -----	
A22	-03	Spring Ass'y, take-up and supply reel table-----	
A23	-07	Bracket Ass'y, power transformer -----	
A24	-08	" " , binaural monitor jack -----	
A25	-09	Knob Ass'y, speed selector -----	
A26	-16	Lever Ass'y, record crank -----	
A27	-17	Lever Ass'y, rewind idler -----	
A28	-20	Bracket Ass'y, jack, socket and fuse Holder -----	
A29	-21	Actuator Ass'y, automatic shut-off -----	
A30	-22	Bracket Ass'y, front panel retainer -----	
A31	-25	Idler Ass'y, take-up -----	
A32	-26	Cam Ass'y, function selector -----	
A33	-27	Lever Ass'y, take-up idler -----	
A34	-38	Bracket Ass'y, volume control -----	
A35	-41	Brake Lever Ass'y, take-up -----	

FOR SERVICE MANUALS
CONTACT:

MAURITRON TECHNICAL SERVICES

www.mauritron.co.uk

TEL: 01844 - 351694

FAX: 01844 - 352554

<u>Ref. No.</u>	<u>Part No.</u>	<u>Description</u>
A36	X-34360-17	Brake Ass'y, instant stop -----
A37	-23	Head Deck Ass'y -----
A38	X-34440-11	Pinch Lever Ass'y -----
A39	X-34380-07	Head Cover Ass'y -----
A40	-10	Button Ass'y, fast forward -----
A41	-13	Knob Ass'y, function selector -----
A42	X-34440-08	Slider Ass'y (C) -----
A43	-09	Idler Ass'y, rewind -----
M1	3-449-618	Reinforcement, handle grip -----
M2	-619	Bracket, SOS potentiometer -----
M3	-620	Name Plate -----
M4	-621	Cap B, knob -----
M5	-622	Cap C, knob -----
	-623	Caution Label, SOS (sound-on-sound) -----
M5-1	-624	Ornamental Plate, record -----
M6	-625	Panel, jack -----
M7	0-007-259	Pad, head -----
M8	-313	Wire, retainer -----
M9	0-027-134	Shaft, stepper -----
M10	-193	Helical Spring -----
M11	-220	Paper Washer 5 ϕ -----
M12	-216	Oil Ring 5 ϕ -----
M13	-473	Pad (B) -----
M14	0-037-249	Sprit Nut (screw 2 ϕ) -----
M15	-406	Tape Guide S -----
M16	0-041-041	Washer (C), reel panel -----
M17	-223	Spacer, jack -----
M18	0-051-235	Wire, retainer -----
M19	0-056-321	Oil Ring -----
M20	-322	" " (B) -----
M21	3-005-001	Spring, record head adjusting -----
M22	3-103-139	Hum-proof Belt, capstan motor -----
M23	-140	Bracket, hum-proof belt, capstan motor -----
M24	-206	Ornamental Washer, cabinet mounting -----
M25	-527	Binder -----
M26	3-401-100	Vibration Absorber; rubber -----
M27	-156	Spacer, mini jack -----
M28	-179	Bracket, wire retainer -----
M29	-482	Washer -----
M30	3-402-654	Shield Plate, head -----
M31	-655	Hinge, head pad; Rec./P.B. Head -----
M32	-764	Spacer, record lever -----
M33	3-405-407	Thrust Washer for Drive Wheel -----
M34	3-409-102	Nylon Washer (B) for Flywheel Shaft -----

2/17 (TC-540 (E))

C 5 - 13

FOR SERVICE MANUALS
CONTACT:
MAURITRON TECHNICAL SERVICES
www.mauritron.co.uk
TEL: 01844 - 351694
FAX: 01844 - 352554

<u>Ref. No.</u>	<u>Part No.</u>	<u>Description</u>
M35	3-409-108	Nylon Washer for Reel Panel Mount -----
M36	-124	Nylon Washer (D) -----
M37	-133	Spring for Pull Rod; rec./p.b. change -----
M38	-158	Spring Lock -----
M39	-163	Nylon Thrust Washer, capstan idler -----
M40	-191	Washer, cabinet -----
M41	3-412-059	Washer for Reel Panel Fix Screw -----
M42	-078	Terminal Strips, head -----
M43	-080	Washer, erase head -----
M44	-121	Shield Case (C) (large) -----
M45	3-413-029	Cord Retainer -----
M46	3-418-009	Shaft, pinch roller up & down adjustable ---
M47	-011	Joint, pinch lever & shifter -----
M48	-035	Plate, instant stop adjusting -----
M49	-054	Spacer, stepper arm -----
M50	-055	Shaft, fast forward -----
M51	-060	Shaft, speed selector -----
M52	-069	Spring, capstan idler arm -----
M53	-073	Spring, capstan idler arm shaft (vertical use) -----
M54	-074	Spring, lever (horizontal use) -----
M55	-075	Spring, idler release lever -----
M56	-077	Spring, idler arm shaft (vertical use) -----
M57	-079	Spring, instant stop lever release -----
M58	-085	Spacer, function selector cam shaft -----
M59	-086	Spacer, instant stop lever -----
M60	-091	Spring, fast forward lever release -----
M61	-107	Support, capstan bearing -----
M62	-111	Cap, capstan bearing -----
M63	-112	Oil Ring, capstan bearing; white -----
M64	-113	Tape Support, right -----
M65	-115	Nylon Washer -----
M66	-167	Tape Support, left -----
M67	-168	Spring, rec/p.b. switch -----
M68	-171	Spring, tape guide height adjusting -----
M69	-191	Screw, rec./p.b. head height lock -----
M70	-200	Spring, brake arm -----
M71	-208	Belt, rewind idler -----
M72	3-419-091	Knob, Felt -----
M73	-098	Nylon Washer 52 -----
M74	-211	Idler Cap -----
M75	-318	Knob (C); bass, treble & speaker mode -----
M76	-320	" (B), volume control; left -----

3/17 (TC-540 (E))

C 5-13

<u>Ref. No.</u>	<u>Part No.</u>	<u>Description</u>
M77	3-419-345	Heat Sink (A) -----
M78	-353	Knob (A), volume control; right -----
M79	-372	Handle Grip -----
M80	3-420-076	Rubber Foam Cushion (Noise Absorber) -----
M81	3-421-031	Spacer, pinch roller -----
M82	3-422-064	Brake Spring -----
M83	3-424-030	Guide, actuator -----
M84	3-428-133	Helical Spring -----
M85	3-430-047	Board, speaker box right; black; cover -----
M86	-113	Shaft, pinch roller -----
M87	-115	Cover, pre-amplifier; fiber -----
M88	-151	Bracket, front panel -----
M89	-152	Bracket, trap coil -----
M90	-153	Plate, microphone jack; bakelite -----
M91	-154	Bracket, speed selector shaft -----
M92	-155	Plate, automatic shut-off actuator switch --
M93	-156	Spring, pinch lever cam -----
M94	-157	Bracket, recording crank -----
M95	-159	Oil Retainer, capstan shaft -----
M96	-160	Oil Ring, reel shaft -----
M97	-161	Counter Pulley -----
M98	-162	Bracket, speed equalizer switch -----
M99	-165	Lever, joint recording clamp -----
M100	-166	Rod, recording crank -----
M101	-167	Lever, record button -----
M102	-169	Bracket, recording -----
M103	-170	Spacer, crank -----
M104	-171	Lever, recording of channel 1 -----
M105	-172	" , " " " 2 -----
M106	-173	Rod, pull; rec./p.b. selector switch -----
M107	-174	Bracket, rec./p.b. amplifier -----
M108	-175	Bracket, leg; power supply and oscillator block side -----
M109	-177	Bracket, leg -----
M110	-178	Chassis, volume, tone control -----
M111	-191	Bracket, muting switch -----
M112	-192	Bracket, power supply and oscillator -----
M113	-193	Plate, decoration; binaural monitor jack ---
M114	-196	Bracket, bias <i>control</i> switch -----
M115	-197	Washer, volume control -----
M116	-199	Washer, recording button; black -----
M117	-200	Washer, recording button; black -----
M118	-201	Shaft, function selector -----
M118	-203	Guide Pin -----

4/17 (TC-540 (E))

C5-73

FOR SERVICE MANUALS
CONTACT:

MAURITRON TECHNICAL SERVICES

www.mauritron.co.uk

TEL: 01844 - 351694

FAX: 01844 - 352554

<u>Ref. No.</u>	<u>Part No.</u>	<u>Description</u>
M119	3-430-206	Cap, take-up and supply reel spindle -----
M120	3-449-631	Knob Felt, record & SOS volume-----
M121	3-430-209	Felt, speaker box -----
M122	-210	Board, speaker box left; black -----
M123	-211	Cushion, VU meter -----
M124	-212	Rod, record locking -----
M125	-213	Pressure Spring, recording -----
M126	-214	Guide, tape; left -----
M127	-215	Shaft, tape guide left -----
M128	-216	Cushion, 2P connector -----
M129	-219	Spring, recording crank -----
M130	-220	Bracket, monaural switch -----
M131	-221	Lever, supply reel brake arm -----
M132	-222	Plate, supply and take-up brake arm joint --
M133	-223	Plate, spring holder -----
M134	-226	Bag, polyethylene -----
M135	-227	Cam, fast forward; lever -----
M136	-231	Felt, pinch roller; oil absorber -----
M137	-232	Cap, pinch roller -----
M138	-233	Roller, pinch -----
M139	-234	Washer, pinch roller; nylon -----
M140	-235	Spacer, pinch roller; metal -----
M141	-236	Washer, front panel; metal -----
M142	-237	Sleeve, capstan shaft-----
M143	-238	Spring, capstan shaft -----
M144	-239	Spring, supply reel brake -----
M145	-240	Cushion, rubber -----
M145-1	-245	Bracket, MIC jack shield -----
M146	-250	Washer, rewind idler -----
M147	-251	Helical Spring, fast forward idler -----
M148	-252	Bracket, switch holder -----
M149	-253	Ornamental Plate -----
M150	-256	Shaft, brake lever; take-up -----
M151	-803	Bracket, shield -----
M152	-805	Cover, jack panel -----
M153	3-431-161	Screw, motor mount -----
M154	3-436-120	Mounting Plate, head -----
M155	-126	Washer, instant stop lever -----
M156	3-437-170	Roller -----
M157	-171	Retainer, roller shaft -----
M158	-229	Insulator (B), miniature jack -----
M159	-271	Knob, instant stop -----
M160	-273	Bracket, carrying handle retainer -----
M161	-274	Bracket, handle grip -----

5/17 (TC-540 (E))

C5-13

<u>Ref. No.</u>	<u>Part No.</u>	<u>Description</u>
M162	3-437-275-03	Knob, volume control (S); SOUND-ON-SOUND ---
	-02	
	-01	
M163	-275-14	" , " " (S); Record volume ----
	-13	
	-12	
M164	3-438-022	Lever, instant stop -----
M165	-033	Bracket, tape index counter -----
M166	-053	Belt, tape index counter -----
M167	-054	Collar, instant stop -----
M168	-056	Head Pad Shifter -----
M169	-058	Bracket, scrap filter rollar -----
M170	3-444-039	Holder, micro S -----
M171	-040	Retainer, instant stop brake lever -----
M172	-049	Shaft, fast forward idler -----
M173	-050	Crank, fast forward idler -----
M174	-063	Motor Pulley, 60 Hz -----
	-064	" " , 50 Hz -----
M175	3-442-030	Helical Spring -----
M176	Y-20410-11	Tape Timer XI Type -----
	3-701-007	Belt (B), tie-up -----
	X-34496-14-1	Carton Ass'y -----

Screw

7-621-255-18	(+) RF 2 x 3 -----
-255-42	(+) RF 2 x 6 -----
-45	(+) RF 2 x 6 -----
-52	(+) RF 2 x 8 -----
-75	(+) RF 2 x 12 -----
-259-12	(+) RF 2.6 x 3 -----
-22	(+) RF 2.6 x 4 -----
-42	(+) RF 2.6 x 6 -----
-52	(+) RF 2.6 x 8 -----
-261-25	(+) RF 3 x 4 -----
-35	(+) RF 3 x 5 -----
-45	(+) RF 3 x 6 -----
-42	(+) RF 3 x 6 -----
-75	(+) RF 3 x 12 -----
-268-45	(+) RF 4 x 6 -----
-52	(+) RF 4 x 8 -----
-98	(+) RF 4 x 15 -----
-62	(+) RF 4 x 10 -----
-661-46	(+) RK 3 x 8 -----
-662-56	(+) RK 3 x 25 -----

6/17 (TC-540 (E))

C5 - 13

FOR SERVICE MANUALS
CONTACT:
MAURITRON TECHNICAL SERVICES
www.mauritron.co.uk
TEL: 01844 - 351694
FAX: 01844 - 352554

<u>Ref. No.</u>	<u>Part No.</u>	<u>Description</u>
	7-621-669-78	(+) RK 4 x 35 -----
	-770-22	(+) B 3 x 6 -----
	-773-77	(+) B 2.6 x 4 -----
	-770-49	(+) B 3 x 6 -----
	-94	(+) B 2.6 x 10 -----
	-92	(+) B 3 x 8 -----
	-848-30	Wooden (+) B 2.7 x 10 -----
	7-621-773-84	(+) B 5 x 25 -----
		<u>Nut</u>
	7-622-108-02	3φ -----
		<u>Washer</u>
	7-623-105-12	2φ -----
	-22	2φ (Large) -----
	-107-02	2.6φ (Small) -----
	-12	2.6φ -----
	-108-12	3φ -----
	-110-02	4φ (Small) -----
	-112-02	5φ (") -----
	-12	5φ -----
	-18	5φ -----
		<u>Spring Washer</u>
	7-623-205-22	2φ -----
	-207-22	2.6φ -----
	-208-22	3φ -----
	-210-22	4φ -----
		<u>Star Washer</u>
	7-623-308-15	3φ (Inner) -----
	-408-05	3φ (Outer) -----
	7-623-508-01	Lug Terminal 3φ -----
		<u>Retaining Ring</u>
	7-624-106-05	E-3 -----
	-108-05	E-4 -----
	-109-05	E-5 -----

7/17 (TC-540 (E))

C5 - 13

Ref.
No.

Part No.

Description

Screw with Spring Washer

7-628-251-25 (+) RF 3 x 6 -----
-35 (+) RF 3 x 8 -----
-55 (+) RF 3 x 12 -----
-75 (+) RF 3 x 16 -----
-257-15 (+) RF 4 x 6 -----

7-629-100-86 Nail R 2 x 6 -----

Carton

3-701-028-01 Tag Label 50 Hz -----
-029-01 " " 60 Hz -----
3-449-628 Carton -----
-629 Cushion, upper -----
-630 " , side -----

Accessories

3-790-268-11 Instruction Manual -----
3-793-009 Inspection Card -----
3-793-010 Tape Talk -----
3-444-063 Motor Pulley (60 Hz) -----
-064 " " (50 Hz) -----
3-701-020 Bag, check sheet; SS -----
-025 Splicing Tape; PS-2 -----
0-041-127 Bag, accessory -----
3-401-193 Tape, cotton -----
3-403-810 Cover, protector -----
3-340-229 Reel Cap (C) -----
7-491-001 Desiccant -----
8-811-960-30 Microphone F-96 (MTL) -----
8-860-107-00 Reel R-7A -----
8-918-210-53 Demonstration Tape DSE-53 -----
1-534-049 Cord, connection RK-74 -----
-099 Power Cord -----
Y-20161-01 Oil OL-1K -----

II. Electrical Parts

E1 (1-538-395 Printed Circuit Board, preamp; P1 -----
X-34496-51 Mounted Circuit Board, preamp; P1 -----

8/17 (TC-540 (E))

C5 - 13

FOR SERVICE MANUALS
CONTACT:

MAURITRON TECHNICAL SERVICES

www.mauritron.co.uk

TEL: 01844 - 351694

FAX: 01844 - 352554

<u>Ref. No.</u>	<u>Part No.</u>	<u>Description</u>
		<u>Transistor</u>
		2SC318 Q104,204 -----
		2SC631 Q102,101,103,201,202, 203 -----
		2SC634 Q105,106,205,206 -----
		<u>Diode</u>
		1T22A D101,102,201,202 -----
		<u>Adjustable Resistor</u>
	1-221-748	5K ohms-B R116,140,216,240 -----
	-401	10K " -B R119,219 -----
		<u>Micro Inductor</u>
	1-407-176	390uH L102,202 -----
	1-409-083	Trap Coil 200uH L101,201 -----
	1-427-174	Transformer, output -----
E2	1-513-220	Slide Switch, rec./p.b. selector switch SW101,102 -----
		<u>Ceramic Capacitor</u>
	1-101-030	200PF +5% 50WV C152,252 -----
		<u>Mylar Capacitor</u>
	1-105-661	0.001uF MFL +10% 50WV C148,150,248,250
	-663	0.0015uF " " C114,149,214,249
	-665	0.0022uF " " C126,226 -----
	-671	0.0068uF " " C118,218 -----
	-673	0.01uF " " C123,124,125,223, 224,225 -----
	-675	0.015uF " " C101,201 -----
	-677	0.022uF " " C102,122,127,129, 202,222,227, 229 -----
	-679	0.033uF MFL +10% 50WV C108,112,151,251, 208,212 -----
	-689	0.22uF " " C128,228 -----

9/17 (TC-540 (E))

C 5 - 13

Ref.
No.

Part No.

Description

Silvered Mica Capacitor

1-107-005	220PF	+10%	50WV	C120,220 -----
-006	330PF	"	"	C106,206 -----
-016	470PF	"	"	C104,117,204,217 --

Electrolytic Capacitor

1-121-344,	3.3uF	+150%	25WV	C130,230 -----		
-456					-10%	
-347,	10uF	+100%	16WV	C110,113,133,210,		
-471,					-10%	213,233,116,216 --
-397						
-284,	33uF	"	6.3WV	C105,205 -----		
-482,						
-401	100uF	"	3.6WV	C107,207 -----		
-290						
-291,	100uF	"	6.3WV	C109,115,132,209,		
-491,					215,232 -----	
-413						
-356,	100uF	"	16WV	C119,219,121,131,		
-415					221,231 -----	
-295,	220uF	"	6.3WV	C111,211 -----		
-318,						
-419						
-358,						
-341,	220uF	"	16WV	C103,203 -----		
-421						

Carbon Resistor

1-248-645,	68 ohms	+10%	ERD14V	ELR½, RD½UR	R107,207
1-242-645					
1-248-647,	82 "	"	"	"	R104,204
1-242-647					
1-248-653,	150 "	"	"	"	R126,226
1-242-653					
1-248-661,	330 "	"	"	"	R132,232
1-242-661					
1-248-665,	470 "	"	"	"	R150,151,
1-242-665					
1-248-667,	560 "	"	"	"	R103,203
1-242-667					

10/17 (TC-540 (E))

C 5 - 13

FOR SERVICE MANUALS
CONTACT:

MAURITRON TECHNICAL SERVICES

www.mauritron.co.uk

TEL: 01844 - 351694

FAX: 01844 - 352054

<u>Ref. No.</u>	<u>Part No.</u>	<u>Description</u>					
	1-248-669, 1-242-669)	680 ohms	<u>+10%</u>	ERD14V	ELR $\frac{1}{2}$,	RD $\frac{1}{2}$ UR	R130,153, 230,253 -
	1-248-673, 1-242-673)	1K	"	"	"	"	R135,149, 137,142, 242,235, 249,237 -
	1-248-679, 1-242-679)	1.8K	"	"	"	"	R147,247 --
	1-248-681, 1-242-681)	2.2K	"	"	"	"	R101,201 --
	1-248-685, 1-242-685)	3.3K	"	"	"	"	R231,236, 238,138, 227,127, 131,136 --
	1-248-687, 1-242-687)	3.9K	"	<u>+5%</u>	"	"	R115,215 --
	1-248-689, 1-242-689)	4.7K	"	<u>+10%</u>	"	"	R125,145, 225,245 --
	1-248-683, 1-242-683)	2.7K	"	"	"	"	R212,214, 112,114 --
	1-248-687, 1-242-687)	3.9K	"	"	"	"	R117,141, 217,241 --
	1-248-691, 1-242-691)	5.6K	"	"	"	"	R124,143, 224,243 --
	1-248-693, 1-242-693)	6.8K	"	"	"	"	R111,211, 120,220 --
	1-248-695, 1-242-695)	8.2K	"	"	"	"	R128,146, 228,246 --
	1-248-697, 1-242-697)	10K	"	"	"	"	R106,206, 148,248 --
	1-248-701, 1-242-701)	15K	"	"	"	"	R129,229 --
	1-248-703, 1-242-703)	18K	"	"	"	"	R110,210, 122,133, 222,233 --
	1-248-705, 1-242-705)	22K	"	"	"	"	R121,221 --
	1-248-709, 1-242-709)	33K	"	"	"	"	R178,278 --

11/17 (TC-540 (E))

C5 - 13

Ref. No.	Part No.	Description
	1-248-713) 1-242-713)	47K ohms $\pm 10\%$ ERD14V ELR $\frac{1}{2}$, RD $\frac{1}{2}$ UL R152,252, 105,118, 205,218--
	1-248-715) 1-242-715)	56K " " " " " R139,239--
	1-248-717) 1-242-717)	68K " " " " " R134,234--
	1-248-721) 1-242-721)	100K " " " " " R102,202--
	1-248-723) 1-242-723)	120K " " " " " R113,213--
	1-248-747) 1-242-747)	1.2M " " " " " R123,223--
E3	1-538-990	Printed Circuit Board, SOUND-ON-SOUND; P5---
	(X-34496-55	Mounted " " , SOUND-ON-SOUND; P5---
E4	1-514-500	Slide Switch SW13; SOUND-ON-SOUND channel selector switch -----
		<u>Mylar Capacitor</u>
	1-106-066) 1-105-665)	0.0022uF MFL $\pm 10\%$ C314,315 -----
		<u>Carbon Resistor</u>
	1-240-505	22K ohms $\pm 5\%$ RD1/8US R311 -----
	-507	27K " " " R309 -----
	-515	56K " " " R310 -----
E5	1-538-396	Printed Circuit Board, power supply & bias osc.; P3 -----
	(X-34496-53	Mounted Circuit Board, power supply & bias osc; P3 -----
		Transistor 2SB383 Q301,302 -----
		Diode SW05-02 D301,302,303,304 --
	1-141-010	Trimmer Capacitor C303,304 -----
	1-431-038	Dummy Coil L301 -----
	1-433-081	Transformer, bias OSC T301 -----
		<u>Mylar Capacitor</u>
	1-105-673	0.01uF MFL $\pm 10\%$ 50WV C301 -----

FOR SERVICE MANUALS
CONTACT:

MAURITRON TECHNICAL SERVICES

www.mauritron.co.uk

TEL: 01844 - 351694

FAX: 01844 - 352554

12/17 (TC-540 (E))

C5 - 13

<u>Ref. No.</u>	<u>Part No.</u>	<u>Description</u>
		<u>Electrolytic Capacitor</u>
	1-121-727, -732, -426	470uF +100% -10% 16WV C305,306 -----
	-733, -234	470uF +150% -10% 25WV C307,308,309 -----
	-094	1000uF " 35WV C310 -----
		<u>Polyethylene Film Capacitor</u>
	1-129-380	0.056uF +5% 600WV C302 -----
		<u>Carbon Resistor</u>
	1-204-528	1 ohm +5% RD $\frac{1}{2}$ SP R307 -----
	1-250-839, 1-204-527	39 ohms " " RD-12T R305 ----
	1-204-530	82 " " RD1SP R304 -----
	-529	270 " " " R303 -----
	1-248-613, 1-242-613	3.3 " +10% ERD14V ELR $\frac{1}{2}$, RD $\frac{1}{2}$ UR R306 ----
	1-248-675, 1-242-675	1.2K " " " " " R301 ----
	1-248-705, 1-242-705	22K " " " " " R302 ----
E6	1-538-435 X-34496-52	Printed Circuit Board, power-amp; P2 ----- Mounted Circuit Board, power-amp; P2 -----
		<u>Transistor</u>
		2SC634 Q108,109,208,209 -----
		2SC633 Q107,207 -----
	1-423-114	Transformer, input -----
		<u>Mylar Capacitor</u>
	1-105-661	0.001uF MFL +10% 50WV C138,238 -----
		<u>Electrolytic Capacitor</u>
	1-119-149	500uF +150% -10% 25WV C141,241 -----

13/17 (TC-540 (E))

C5 - 13

FOR SERVICE MANUALS
CONTACT:
MAURITRON TECHNICAL SERVICES
www.mauritron.co.uk
TEL: 01844 - 351694
FAX: 01844 - 352554

Ref.
No.

Part No.	Description
1-121-347, -471, -397, -350, -485, -403, -286, -373, -404, -291, -491, -413	10uF +100% 16W C135,235 ----- -10% 33uF " " C137,237 ----- 33uF " 25W C140,142,240,242 -- 100uF " 6.3W C136,236 -----

Carbon Resistor

1-248-645, 1-242-645)	68 ohms +10% ERD14V ELR $\frac{1}{2}$, RD $\frac{1}{2}$ UR R162,262 --
1-248-657, 1-242-657)	220 " " " " " R170,172, 270,272 --
1-248-663, 1-242-663)	390 " " " " " R165,265 --
1-248-671, 1-242-671)	820 " " " " " R161,261 --
1-248-677, 1-242-677)	1.5K " " " " " R158,258 --
1-248-679, 1-242-679)	1.8K " " " " " R166,266 --
1-248-681, 1-242-681)	2.2K " " " " " R168,268 --
1-248-689, 1-242-689)	4.7K " " " " " R160,260 --
1-248-691, 1-242-691)	5.6K " " " " " R163,164, 263,264 --
1-248-701, 1-242-701)	15K " " " " " R159,259 --
1-248-675, 1-242-675)	1.2K " " " " " R175,275 --
1-248-656, 1-242-656)	200 " " " " " R167,169, 267,269 --
1-204-528	1 ohm +5% RD $\frac{1}{2}$ SP R173,174,273,274 --

14/17 (TC-540 (E))

C 5 - 13

FOR SERVICE MANUALS
CONTACT:
MAURITRON TECHNICAL SERVICES
www.mauritron.co.uk
TEL: 01844 - 351694
FAX: 01844 - 352554

<u>Ref. No.</u>	<u>Part No.</u>	<u>Description</u>
E7	1-538-679	Printed Circuit Board, noise suppressor; P6-
	X-34300-66	Mounted " " " " ; P6-
E8	1-514-314	Slide Switch S12-1, 12-2; Noise Suppressor
	1-129-128	Switch Capacitor, polyethylene ----- 750PF <u>+10%</u> C253,153 -----
		<u>Transistor</u>
E9		2SD28 Q110,111,210,211 -----
E10	8-821-242	Rec./P.B. Head; PP30-4202N -----
E11	8-826-629	Erase Head; EF18-2902H -----
E12	8-832-624	Motor -----
		<u>Potentiometer</u>
E13	1-221-749	10K ohms R157,257; record volume-
E14	-750	50K " R156,256; volume control
E15	-751	50K " R154,155,254,255; bass & treble -----
E16	1-222-193	20K " A with SW14 R308; -----
E17	1-409-106	Trap Coil L103,203 -----
	1-421-153	Deviding Coil; filter -----
E18	1-441-262	Transformer, power -----
E19	1-502-125	Speaker -----
E20	-154	" -----
E20-1	1-506-121	Cord, with plug -----
E21	1-507-053	Jack J102,202; microphone ---
E22	-106	" J105; headphone -----
E23	-108	" J104,204; lid speaker --
E24	-142	Jack, 2P pin J101,103,201,203; AUX & LINE OUT -----
E25	1-509-015	Socket, AC CNJ302,303 -----
E26	-029	Rec./P.B. Connector -----
E27	-062	Socket, AC input CNJ301 -----
E28	-064	Socket, power voltage selector VS -----
E29	-117	Connector, cabinet speaker (CNJ101,201, CNP201,101 -----
E30	1-513-091	Switch, slide SW5; EXT/LID speaker change switch -----
E31	1-514-039	" micro SW6; automatic SHUT-OFF switch -----
E32	-055	" leaf SW3; muting switch -----

15/17 (TC-540 (E))

C 5 - 13

<u>Ref. No.</u>	<u>Part No.</u>	<u>Description</u>
E33	1-514-057	Switch, micro SW11; bias ON/OFF switch ----
E34	-140	" , power SW7; power ON/OFF switch ----
E35	-226	" , rotary SW1; equalizer switch -----
E36	-247	" , leaf SW9,10; monaural/record switch
E37	-301	" , seesaw SW4; speaker ON/OFF switch --
E38	-499	" , rotary SW2; speaker mode switch ----
E39	-485	" , leaf SW8; bias control switch ----
E41	1-517-003	Socket, pilot lamp -----
E42	1-518-052	Pilot Lamp PL1,2 -----
E43	1-524-051	VU Meter ME101,201 -----
E44	1-532-165	Fuse 1.5A -----
E45	1-533-048	Fuse Holder -----
E46	1-536-030	Lug, small 2-L-2 -----
E47	-061	" " 2-L-1 -----
E48	-146	Terminal Strips 1-L-1 -----
E49	1-538-464	Printed Circuit Board, speaker circuit; P4 -
	X-34496-54	Mounted Circuit Board, speaker circuit; P4 -

Encapsulated Component C-R Capacitor

E50 1-101-534 0.1uF \pm 120 ohms 500WV CP1,2 -----

Silvered Mica Capacitor

1-107-123 47PF \pm 10% 50WV C154,254 -----
 -008 150PF " " C312,313 -----
 -006 330PF " " C134,234 -----

MP Capacitor

E51 1-117-036 1.5uF \pm 0.5uF C311 -----

Electrolytic Capacitor

1-119-173 50uF \pm 20%. 50WV C147,247 -----

Carbon Resistor

1-204-537 2.2 ohms \pm 10% RD2SP R208,209,108,
 109 -----

Wire Wound Resistor

1-207-084 8 ohms \pm 10% 6WV R171,271 -----

16/17 (TC-540 (E))

CJ - 13

FOR SERVICE MANUALS
 CONTACT:
MAURITRON TECHNICAL SERVICES
 www.mauritron.com
 TEL: 01842 211111
 FAX: 01842 211111

<u>Ref. No.</u>	<u>Part No.</u>	<u>Description</u>		
		<u>Carbon Resistor</u>		
	1-242-663-31, -32)	390 ohms	+10%	RD½UR, ELR½ R179,279 ----
	1-246-697, 1-244-697)	10K "	+5%	ERD14T RD½SR R277,276, 177,176 ---

FOR SERVICE MANUALS
CONTACT:
MAURITRON TECHNICAL SERVICES
www.mauritron.co.uk
TEL: 01844 - 351004
FAX: 01844 - 352554

17/17 (TC-540 (E))

C 5 - 13