

REALISTIC[®]

Service Manual

20-152

Model DX-160

SOLID STATE FIVE BAND COMMUNICATIONS RECEIVER

Catalog Number: 20-152



CUSTOM MANUFACTURED FOR RADIO SHACK  A TANDY CORPORATION COMPANY

CONTENTS

	Page
1. SPECIFICATIONS	1
2. DISASSEMBLY	2
3. ALIGNMENT SET-UP DIAGRAM	4
4. ALIGNMENT PROCEDURE	5
5. BFO ALIGNMENT	7
6. PRINTED CIRCUIT BOARD PARTS LOCATION (TOP VIEW).....	8
7. COIL PACK (TOP VIEW)	8
8. COIL PACK (BOTTOM VIEW)	9
9. BLOCK DIAGRAM	9
10. PRINTED CIRCUIT WIRING DIAGRAM	10
11. TROUBLE SHOOTING	11
12. PARTS LIST	12

NOTICE:

This service manual is for products manufactured after August 20, 1973

When replacing UL or CSA approved parts, use only approved parts of the same value.

SPECIFICATIONS

Description	Condition	Nominal Spec.	Limit Spec.
Frequency coverage	Band A Band B Band C Band D Band E	150 – 400 kHz 535 – 1605 kHz 1.5 – 4.5 MHz 4.5 – 13 MHz 13 – 30 MHz	150 – 400 kHz 535 – 1605 kHz 1.5 – 4.5 MHz 4.5 – 13 MHz 13 – 30 MHz
Sensitivity (S+N)/N = 10 dB Output = 50 mW (Thru I.E.C. Dummy ANT.)	250 kHz 1 MHz 2.5 MHz 7 MHz 21 MHz	50 μ V 100 μ V 3 μ V 4 μ V 4 μ V	200 μ V 300 μ V 10 μ V 10 μ V 10 μ V
Selectivity	-6 dB -40 dB	4 kHz 18 kHz	4.5 kHz 20 kHz
Image ratio (Thru I.E.C. Dummy ANT.)	250 kHz 1 MHz 2.5 MHz 7 MHz 21 MHz	48 dB 65 dB 45 dB 35 dB 20 dB	40 dB 50 dB 40 dB 30 dB 15 dB
Signal to Noise ratio	1 mV at 7 MHz AM SSB	50 dB 40 dB	40 dB 30 dB
Intermediate frequency		455 kHz	455 kHz
B.F.O. Pitch		\pm 2.5 kHz	\pm 2 kHz
AVC action	50 μ V to 20 mV at 7 MHz	\pm 60 dB	\pm 10 dB
Audio frequency response	AM: 300 Hz to 3 kHz SSB: 300 Hz to 3 kHz	-6 dB -6 dB	+3, -10 dB +3, -10 dB
Audio output power	Less than 10% T.H.D.	700 mW	500 mW
Hum and Noise	AF Gain Minimum AM SSB	4.5 mV 6 mV	10 mV 10 mV
Power drain	1. Idling AC 120V, 60 Hz DC 12V 2. Full power AC 120V, 60 Hz DC 12V	3 W 30 mA 6 W 180 mA	4 W 60 mA 10 W 300 mA
Dial calibration accuracy	Main Tuning Bandsread	\pm 1 % \pm 0.1 %	\pm 3 % \pm 0.5 %
Oscillator drop-out	AC DC	120 V 12 V	100 V 9 V

Semiconductors : 1 IC, 5 FET's, 6 Transistors and 15 Diodes
 Reception : AM, CW and Single Side Band (USB/LSB)
 Power source : 120 Volt AC 60 Hz or
 12 Volt DC Negative Ground only.
 Antenna : Low impedance
 Phones jack matching impedance : More than 8.ohm
 Operating temperature : 0°C to 40°C
 Dimensions : 6-9/16"(H) x 14-1/5"(W) x 8-7/8"(D)
 Weight : 16 lbs.

DISASSEMBLY

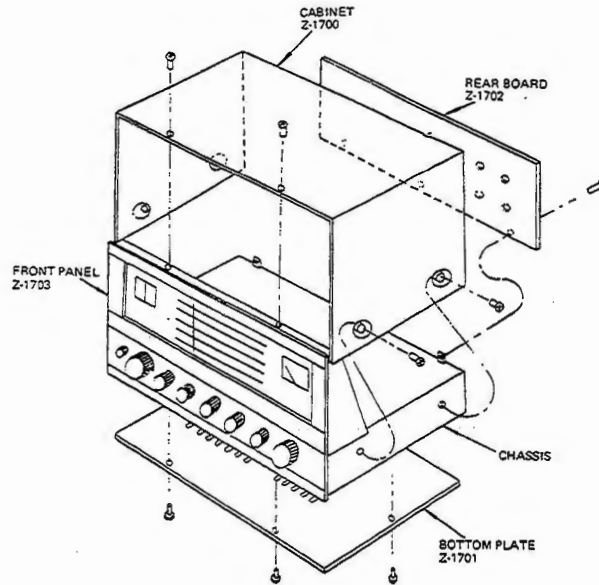

DISASSEMBLY INSTRUCTIONS

1. Remove 6 screws from bottom plate.
2. Remove 6 screws from rear Board.
3. Remove 4 screws holding cabinet.

KNOB AND SHAFT ASSEMBLIES

BAND SPREAD, BAND SWITCH
AND MAIN TUNING

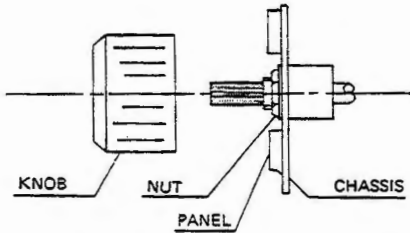

BFO PITCH, AF GAIN,
ANT TRIM, RF GAIN

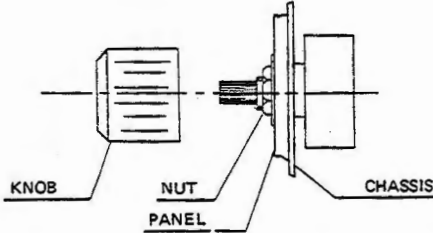

PHONES JACK

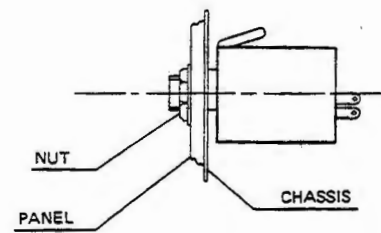

Knob Positioning for B.F.O. Pitch & Antenna Trimmer

When the variable capacitor is at maximum (plates fully meshed),
the Knob markers should be at the 9 o'clock position.

TOP VIEW OF DX-160 CHASSIS

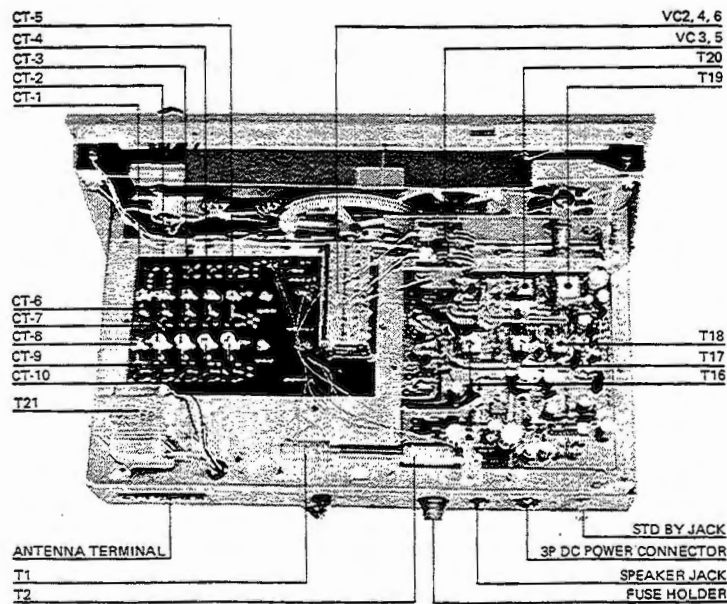

BOTTOM VIEW OF DX-160

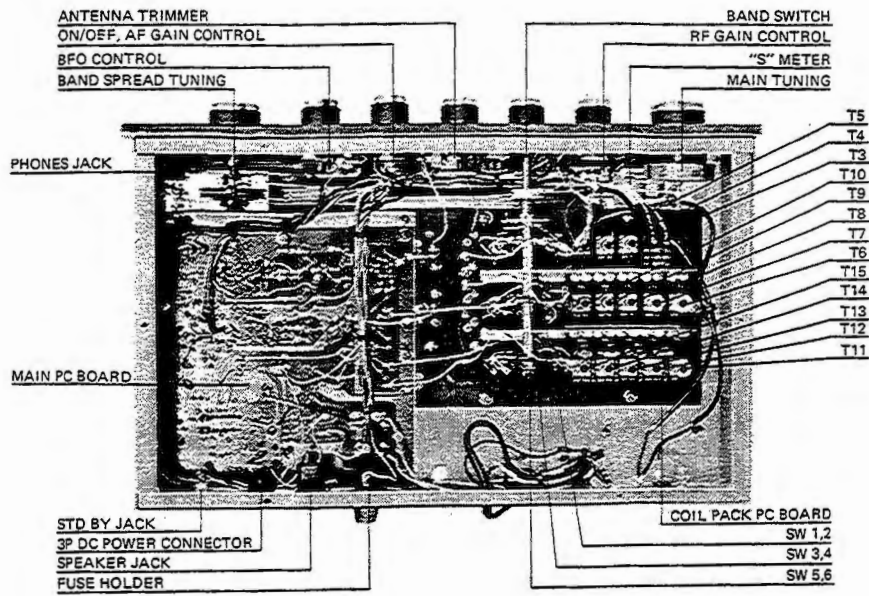

MAIN TUNING DIAL STRINGING ASSEMBLY

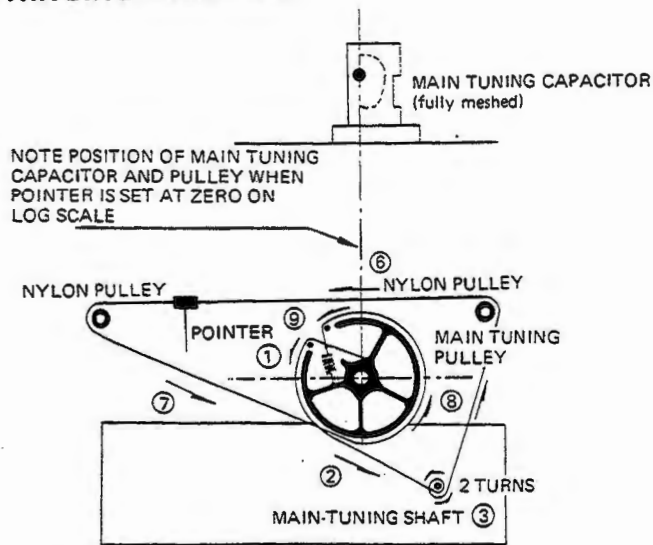

BAND SPREAD DIAL STRINGING ASSEMBLY

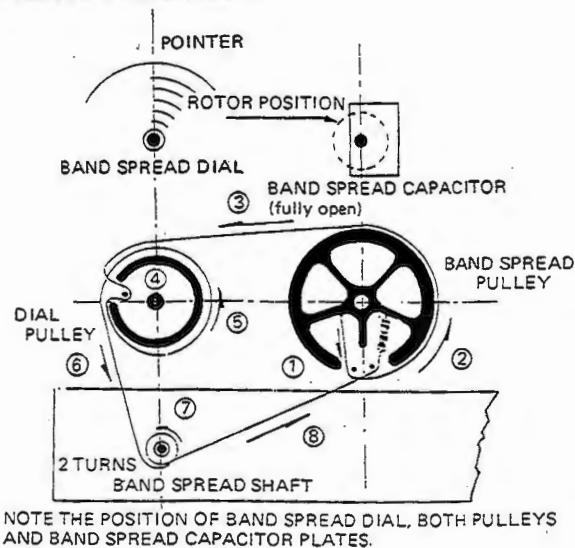

ALIGNMENT SET-UP DIAGRAM

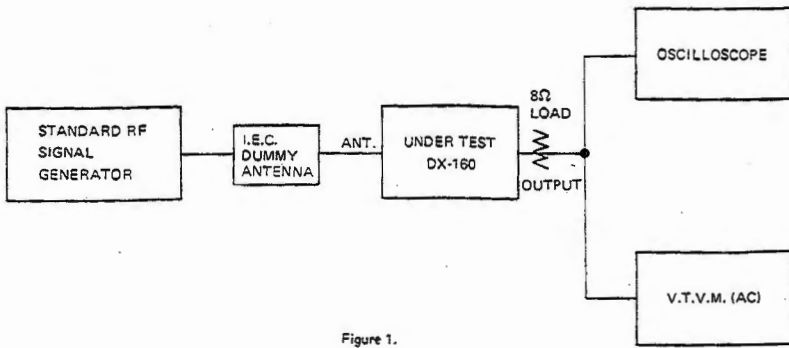
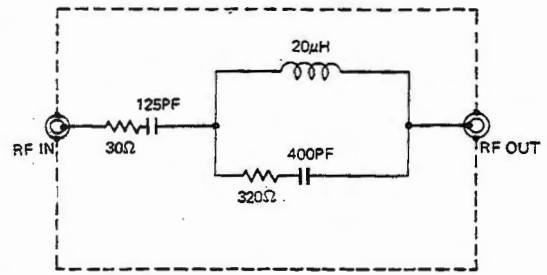
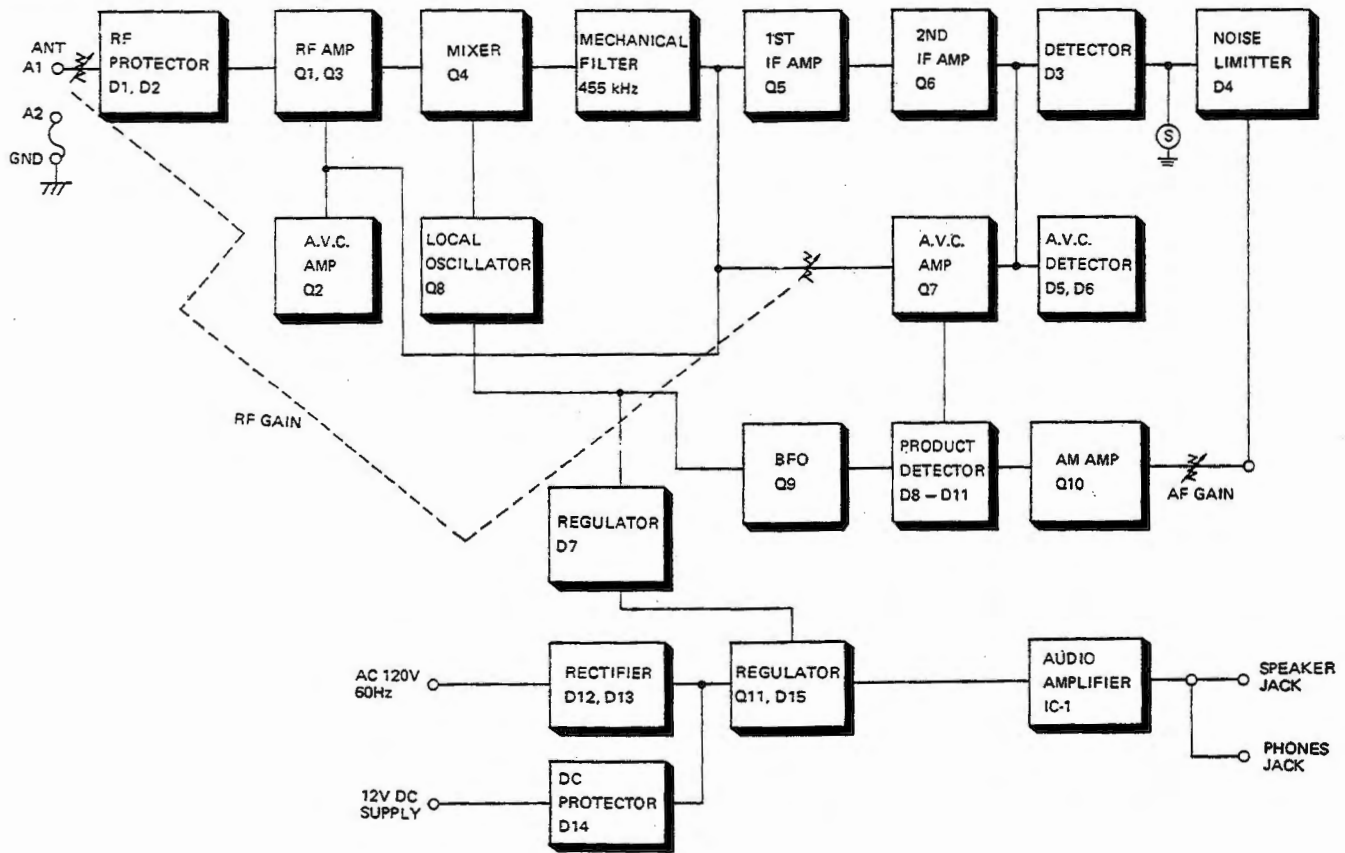

Figure 1.

I.E.C. DUMMY ANTENNA DIAGRAM



BLOCK DIAGRAM



IC EQUIVALENT SCHEMATIC DIAGRAM

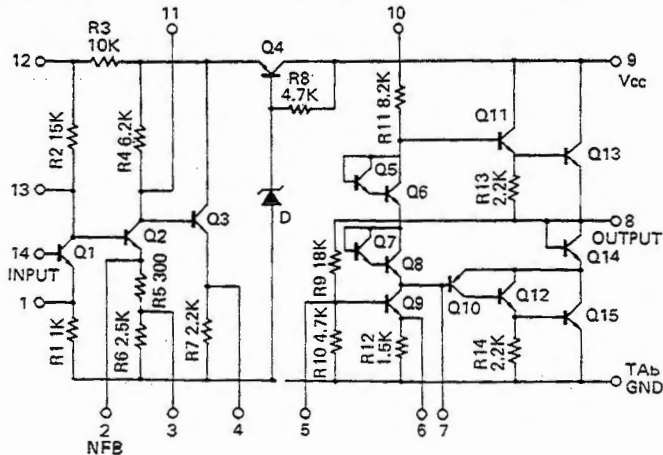

IC PIN CONFIGURATION

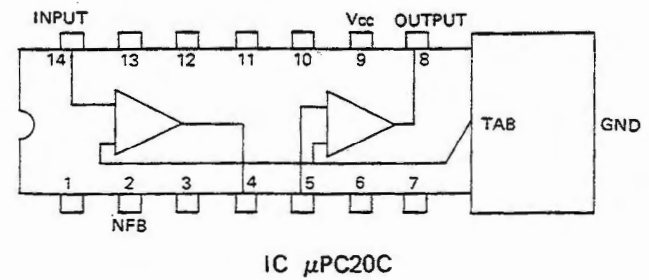

ALIGNMENT PROCEDURE

Set up test equipment as shown in Figure 1. For all alignment steps, keep output level of signal generator as low as possible and still obtain a usable output.

STEP	RF SIGNAL GENERATOR CONNECTION	SET SIGNAL GENERATOR TO:	CONNECT ALIGNMENT INDICATOR TO:	SET RECEIVER DIAL TO:	ADJUSTMENT FOR V.T.V.M. INDICATION
IF STAGES					
1	RF Generator to Q4 Gate through a 0.01 μ F Capacitor	455 kHz (Modulated)	VTVM: across speaker voice coil	Band Selector: A 455 kHz (Tuning capacitor fully open)	T16- maximum.
2					T17- maximum.
3					T18- maximum.
4	Repeat Steps 1, 2 and 3.				
BAND A: RF STAGE					
5	RF Generator to a standard radiating loop, or to a short piece or loop of wire placed near AM antenna.	400 kHz (Modulated)	VTVM: across speaker voice coil or across 8 ohm dummy load.	400 kHz (Tuning capacitor fully open)	CT6 (OSC trimmer) – for maximum.
6		150 kHz (Modulated)		150 kHz (Tuning capacitor fully closed.)	T11 (OSC coil) – for maximum.
7		350 kHz (Modulated)		350 kHz	CT1 (RF trimmer) – for maximum.
8					VC1 (Ant. trimmer) – for maximum.
9		180 kHz (Modulated)		180 kHz	T6 (RF trans) – for maximum.
10			T1 (ferrite ant. coil) – for maximum by sliding ant. coil on core.		
11	Repeat Steps 5 through 10.				
12	Check sensitivity and repeat steps 1 through 11 as necessary until required sensitivity is obtained.				
BAND B: RF STAGE					
13	RF Generator to a standard radiating loop, or to a short piece or loop of wire placed near AM antenna.	1600 kHz (Modulated)	VTVM: across speaker voice coil or across 8 ohm dummy load	1600 kHz (Tuning capacitor fully open)	CT7 (OSC trimmer) – for maximum.
14		535 kHz (Modulated)		535 kHz (Tuning capacitor fully closed)	T12 (OSC coil) – for maximum.
15		1400 kHz (Modulated)		1400 kHz	CT2 (RF trimmer) – for maximum.

STEP	RF SIGNAL GENERATOR CONNECTION	SET SIGNAL GENERATOR TO:	CONNECT ALIGNMENT INDICATOR TO:	SET RECEIVER DIAL TO:	ADJUSTMENT FOR V.T.V.M. INDICATION
16		600 kHz (Modulated)		600 kHz	VC1 (Ant. trimmer) – for maximum. (about 2 o'clock)
17					T7 (RF trans) – for maximum.
18					T2 (ferrite ant. coil) – for maximum by sliding ant. coil or core.
19	Repeat Steps 13 through 18.				
20	Check sensitivity and repeat steps 13 through 18 as necessary until required sensitivity is obtained.				
BAND C: RF STAGE					
21	RF Generator: across antenna terminals through a dummy antenna	4.5 MHz (Modulated)	VTVM: across speaker voice coil or across 8 ohm dummy load.	4.5 MHz (Tuning capacitor fully open)	CT8 (OSC trimmer) – for maximum.
22		1.5 MHz (Modulated)		1.5 MHz (Tuning capacitor fully closed)	T13 (OSC coil) – for maximum.
23		4 MHz (Modulated)		4 MHz	CT3 (RF trimmer) – for maximum.
24					
25		1.8 MHz (Modulated)		1.8 MHz	T8 (RF Trans) – for maximum.
26					T3 (Ant. trans) – for maximum.
27	Repeat Steps 21 through 26.				
28	Check sensitivity and repeat steps 21 through 26 as necessary until required sensitivity is obtained.				
BAND D: RF STAGE					
29	RF Generator across antenna terminals through a dummy antenna.	13 MHz (Modulated)	VTVM: across speaker voice coil or across 8 ohm dummy load.	13 MHz (Tuning capacitor fully open)	CT9 (OSC trimmer) – for maximum.
30		4.5 MHz (Modulated)		4.5 MHz (Tuning capacitor fully closed)	T14 (OSC coil) – for maximum.

STEP	RF SIGNAL GENERATOR CONNECTION	SET SIGNAL GENERATOR TO:	CONNECT ALIGNMENT INDICATOR TO:	SET RECEIVER DIAL TO:	ADJUSTMENT FOR V.T.V.M. INDICATION
31	RF Generator across antenna terminals through a dummy antenna.	12 MHz (Modulated)	VTVM: across speaker voice coil or across 8 ohm dummy load	12 MHz	CT4 (RF-trimmer) – for maximum. (about 1 o'clock)
32					VC1 (Ant. trimmer) – set to center. (12 o'clock)
33		5 MHz (Modulated)		5 MHz	T9 (RF trans) – for maximum.
34					T4 (Ant. trans) – for maximum.
35	Repeat Steps 29 through 34.				
36	Check sensitivity and repeat steps 29 through 34 as necessary until required sensitivity is obtained.				
BAND E: RF STAGE					
37	RF Generator across antenna terminals through a dummy antenna.	30 MHz (Modulated)	VTVM: across speaker voice coil or across 8 ohms dummy load.	30 MHz (Tuning capacitor fully open)	CT10 (OSC trimmer) – for maximum.
38		14 MHz (Modulated)		14 MHz (Tuning capacitor fully closed)	T15 (OSC coil) – for maximum.
39		28 MHz (Modulated)		28 MHz	CT5 (RF trimmer) – for maximum.
40					VC1 (Ant. trimmer) – for maximum.
41		14 MHz (Modulated)		14 MHz	T10 (RF trans) – for maximum.
42					T5 (Ant. trans) – for maximum.
43	Repeat Steps 37 through 42.				
44	Check sensitivity and repeat steps 37 through 42 necessary until required sensitivity is obtained.				

BFO ALIGNMENT

Note: Be sure BFO capacitor is fully meshed when BFO control is at 9 o'clock position. If not, reset knob on shaft.

1. Set MODE switch to SSB/CW. Set BFO to the one o'clock position.
2. Connect an antenna to the receiver and tune in a station to the exact center of the signal.
3. Set VTVM to 1.5 volt range. Connect VTVM between one side of T20 secondary and chassis ground.
4. Adjust the core of BFO coil T19 for a zero beat note in loud speaker.
5. Adjust the core of BFO coil T20 for maximum deflection on the VTVM.

P. C. BOARD (TOP VIEW)

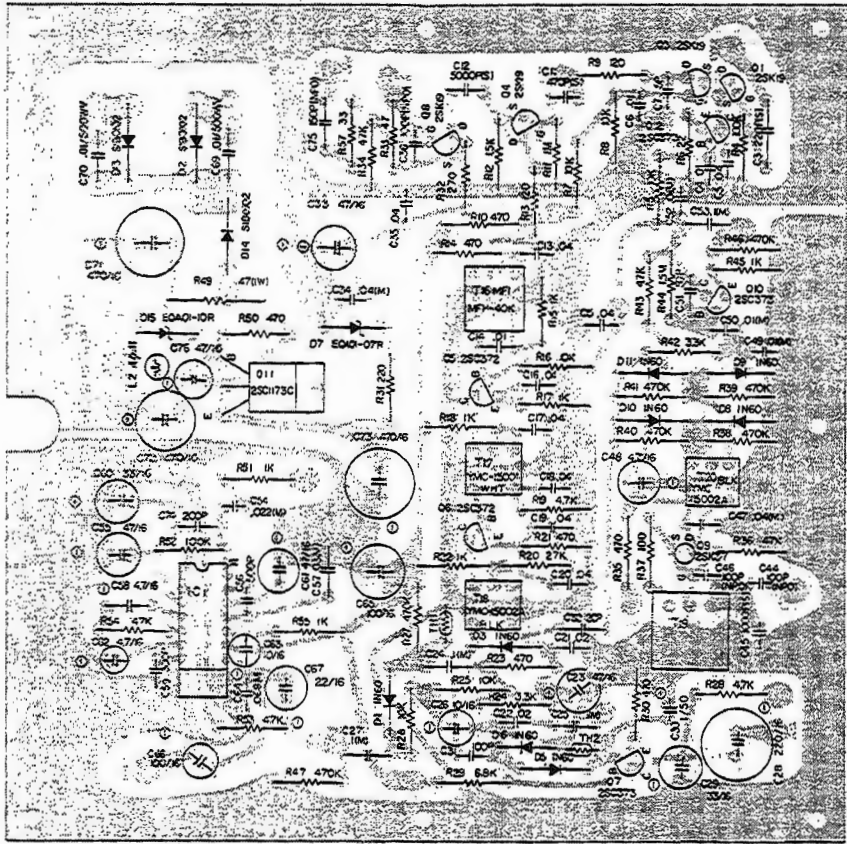

P. C. BOARD (BOTTOM VIEW)

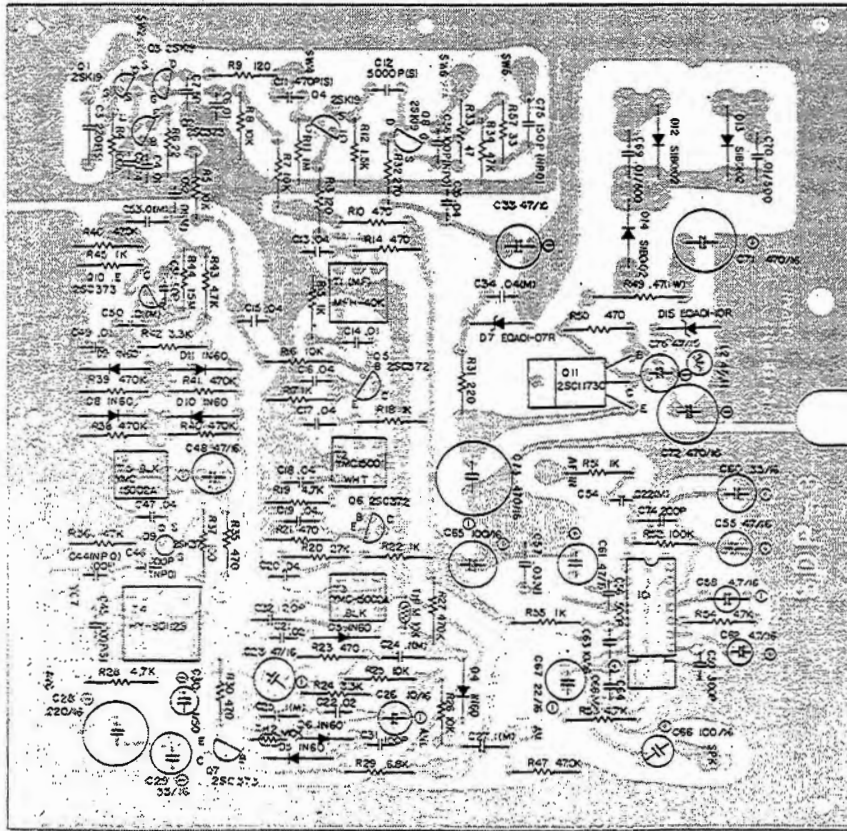

COIL PACK P.C. BOARD (TOP VIEW)

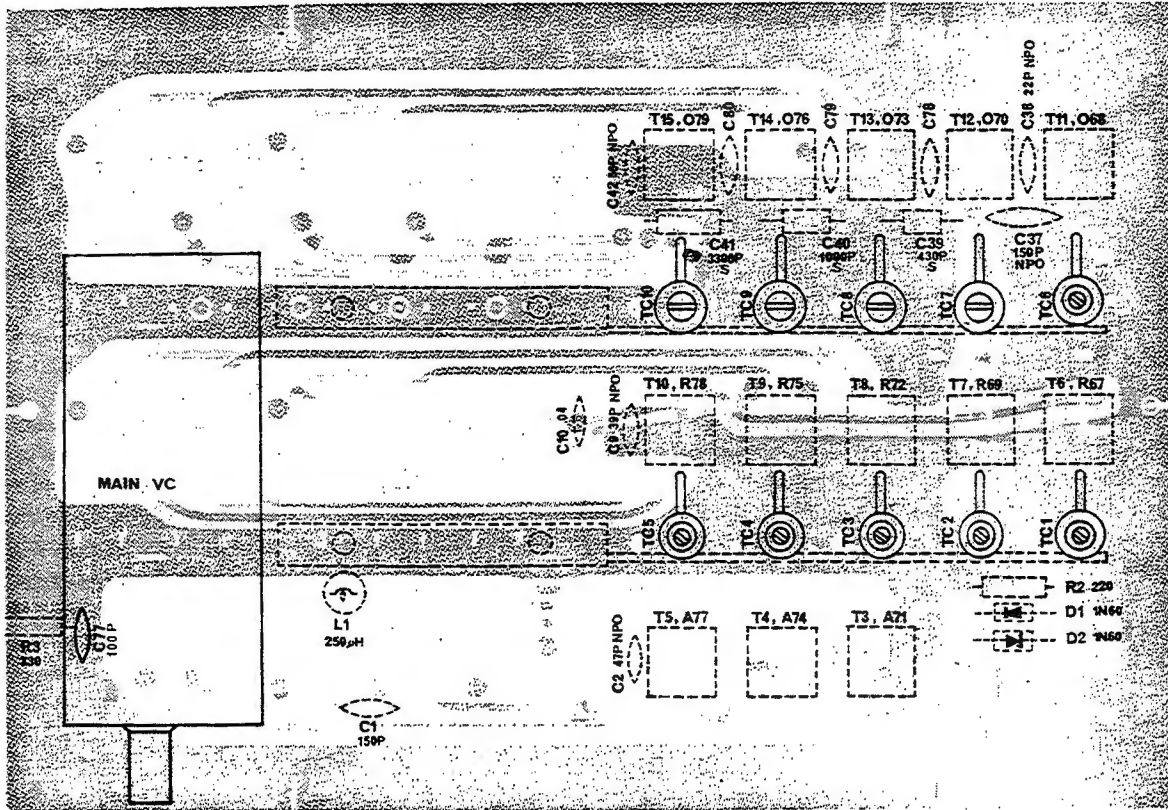

COIL PACK P.C. BOARD (BOTTOM VIEW)

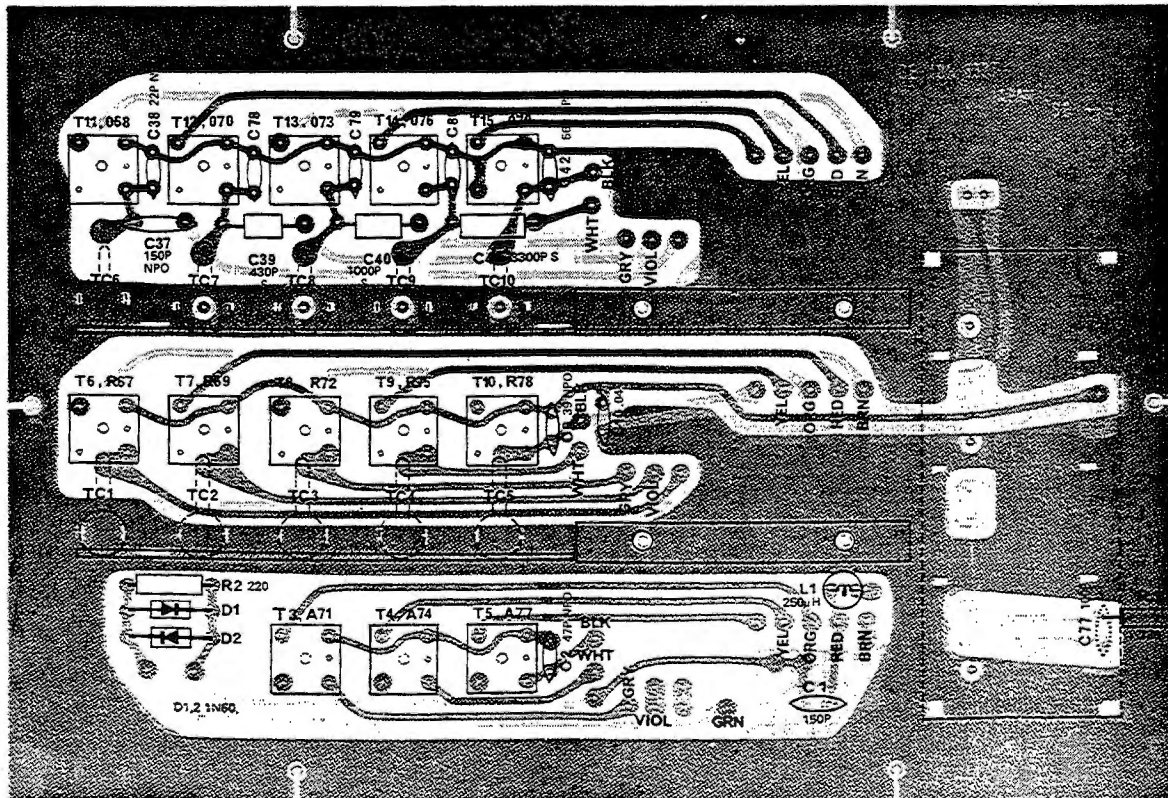

P.C. BOARD WIRING DIAGRAM

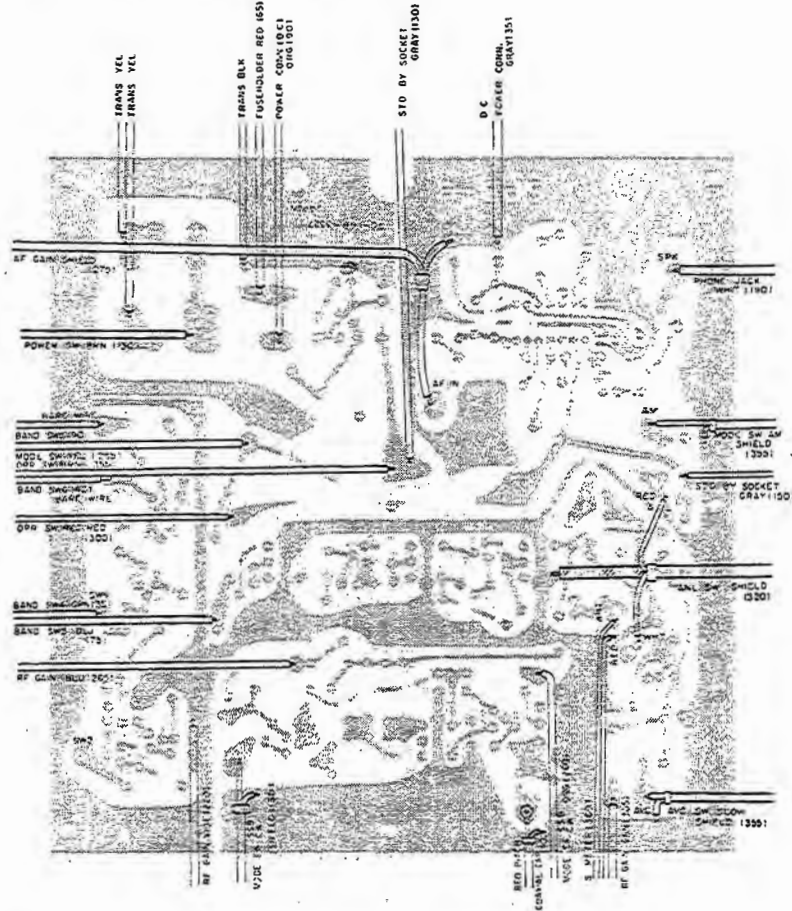

COIL PACK P.C. BOARD WIRING DIAGRAM

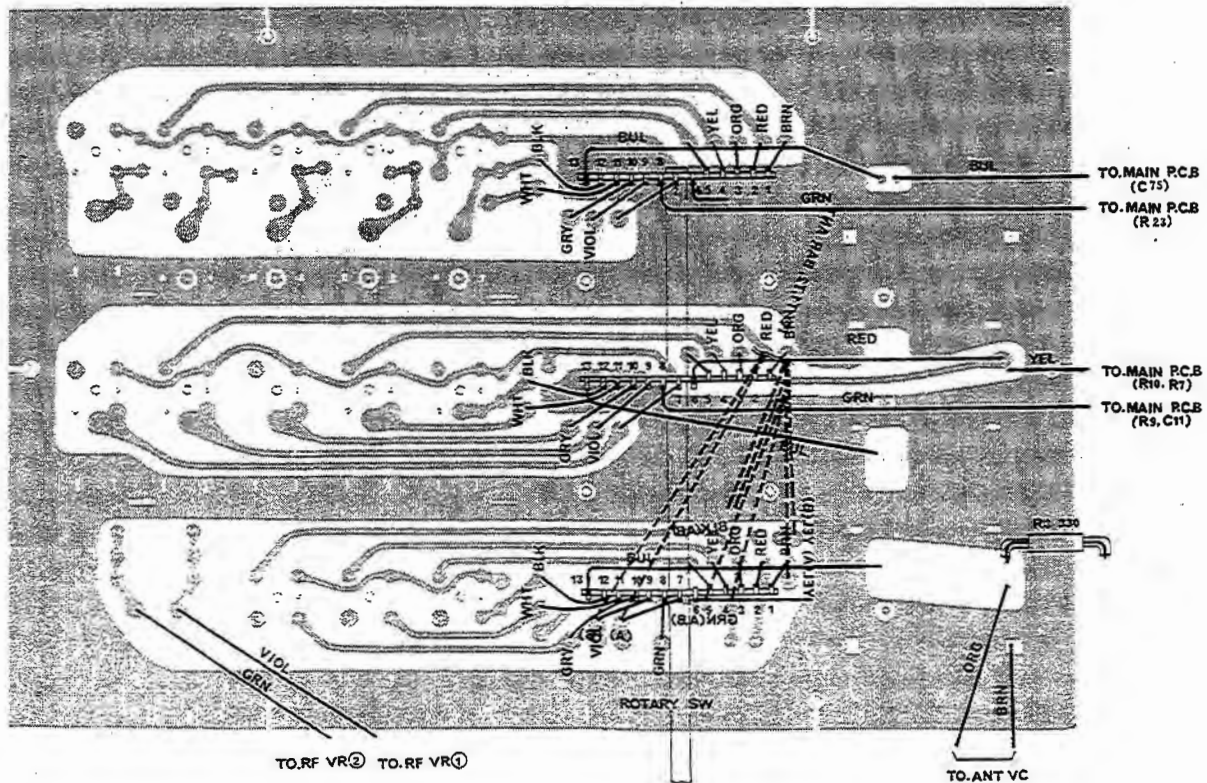

TROUBLESHOOTING

Symptom	Possible Cause
1) Pilot lamp does not light, and the unit does not function when power is ON.	A) Faulty line power cord. B) Defective power switch on AF GAIN VR3. C) Defective power Transformer T21.
2) Fuse blows when power is switched on.	A) Defective Electrolytic capacitor C71. B) Short-circuit in the DC regulator circuit. C) Short-circuit in the power amplifier circuit.
3) Dial lamp and meter lamp does not light.	A) Defective Dial lamp or defective meter lamp. B) Defective power on AF GAIN VR3.
4) Dial lamp glows but no sound on any band.	A) Speaker Jack or Phones Jack defective. B) Blown 0.5A fuse. C) Faulty speaker coupling capacitor C66. D) Power amplifier (IC1) defective. E) Short circuit in the DC regulator circuit. F) Faulty power switch on AF GAIN VR3. G) Faulty STD BY switch.
5) No audio on any band.	A) Defective local oscillator or defective oscillator circuit component. B) Faulty RF stage amplifier or faulty RF stage amplifier circuit component.
6) BFO Control has no effect.	A) Defective slide switch, SW9. B) Defective capacitor C45. C) Faulty BFO circuit or faulty BFO circuit component.
7) S-meter not operating.	A) Defective S-meter B) Defective capacitor C23. C) Faulty AVC circuit or faulty AVC circuit component.
8) Noisy	A) Defective RF Stage amplifier. B) Defective IF Stage amplifier. C) Defective AF amplifier IC1.

PARTS LIST

Ref. No.	RS Parts Number	MFR's Parts Number	Description			
CAPACITORS						
C1		FC801H151	Ceramic	150PF		
C2		CC801H470	Ceramic	47PF (NPO)		
C3		SOA1H221J	Polystyrene	220PF (H)		
C4, 6, 14		SO801H104	Ceramic	0.01 μ F		
C5, 10, 13, 15~20, 35		SC1201H404	Ceramic	0.04 μ F		
C7		FC501H050	Ceramic	5PF		
C9		FC501H390M	Ceramic	39PF		
C11		SOC1H471K	Polystyrene	470PF (V)		
C12		SOA1H502J	Polystyrene	5000PF (V)		
C21, 22		SC801H204	Ceramic	0.02 μ F		
C23, 48, 55, 61, 72, 76		CE04W1C470B	Electrolytic	47 μ F16WV		
C24, 25, 27, 53		MS1H-1045	Mylar	0.1 μ F		
C26, 63		CE04W1C100F	Electrolytic	10 μ F16WV		
C28		CE04W1C221E	Electrolytic	220 μ F16WV		
C29, 60		CE04W1C330C	Electrolytic	33 μ F16WV		
C30		CE04W1H010	Electrolytic	1 μ F50WV		
C31, 44		FC701H101M	Ceramic	100PF		
C32		FC501H200M	Ceramic	20PF		
C33, 71, 73		CE04W1471B	Electrolytic	470 μ F16WV		
C34, 47		MS1H-403	Mylar	0.04 μ F		
C36, 46		CC1251H101	Ceramic	100PF (NPO)		
C37, 75		CC1251H151	Ceramic	150PF (NPO)		
C38		CC631H220	Ceramic	22PF (NPO)		
C39		SOA1H431J	Polystyrene	430PF (H)		
C40		SOA1H102J	Polystyrene	1000PF (H)		
C41, 43		SOA1H332J	Polystyrene	3300PF (H)		
C42		CC101H560	Ceramic	56PF (NPO)		
C45		SOC1H102K	Polystyrene	1000PF (V)		
C49, 50, 52		MS1H103	Mylar	0.01 μ F		
C51		FC601H500M	Ceramic	50PF		
C54		MS1H-223	Ceramic	0.022 μ F		
C56		SCP501H501M	Ceramic	500PF		
C57		MS1H-303	Mylar	0.03 μ F		
C58, 62		CE04W1H4R7	Electrolytic	4.7 μ F16WV		
C59		FC901H301M	Ceramic	300PF		
C64		MS1H-683	Ceramic	0.068 μ F		
C65, 66		CE04W1C101F	Electrolytic	100 μ F16WV		
C67		CE04W1C220	Electrolytic	22 μ F16WV		
C68		ECK-DAL102P	Ceramic	0.001 μ F		UL listed
C69, 70		ECKD2H104MD	Ceramic	0.1 μ F500WV		
C74		FC801H201M	Ceramic	200PF		
Deletion: C78, C79, C80						
Note: V = Vertical type polystyrene capacitor. H = Horizontal type polystyrene capacitor.						
RESISTORS						
R1, 48		FRD12T-185J	Carbon film	1.8M Ω	\pm 10%	1/2W
R2, 31		ERD14T-221	Carbon film	220 Ω	\pm 10%	1/4W
R3		ERD14T-331	Carbon film	330 Ω	\pm 10%	1/4W
R4, 52		ERD14T-104	Carbon film	100k Ω	\pm 10%	1/4W
R5, 7, 8, 16, 25, 26		ERD14T-103	Carbon film	10k Ω	\pm 10%	1/4W
R6		ERD14T-220J	Carbon film	22 Ω	\pm 10%	1/4W

Ref. No.	RS Parts Number	MFR's Parts Number	Description			
R9, 13		ERD14T-121	Carbon film	120Ω	±10%	1/4W
R10, 14, 21, 23, 30, 35, 50		ERD14T-471	Carbon film	470Ω	±10%	1/4W
R11		ERD14T-105	Carbon film	1MΩ	±10%	1/4W
R12		ERD14T-152	Carbon film	1.5kΩ	±10%	1/4W
R15, 17, 18, 22, 45, 51, 55		ERD14T-102	Carbon film	1kΩ	±10%	1/4W
R19, 28, 43, 54, 54		ERD14T-472	Carbon film	4.7kΩ	±10%	1/4W
R20		ERD14T-273	Carbon film	27kΩ	±10%	1/4W
R24, 42		ERD14T-332	Carbon film	3.3kΩ	±10%	1/4W
R27, 38, 39, 40, 41, 46, 47		ERD14T-474	Carbon film	470kΩ	±10%	1/4W
R29		ERD14T-682	Carbon film	6.8kΩ	±10%	1/4W
R32		ERD14T-271	Carbon film	270Ω	±10%	1/4W
R33		ERD14T-101	Carbon film	470Ω	±10%	1/4W
R34, 36		ERD14T-473	Carbon film	47kΩ	±10%	1/4W
R37		ERD14T-101	Carbon film	100Ω	±10%	1/4W
R44		ERD14T-155	Carbon film	1.5MΩ	±10%	1/4W
R49		RS-1	Metal film	0.47Ω	±10%	1W
R56		ERD14T-820	Carbon film	82Ω	±10%	1/4W
R57		ERD14T-330	Carbon film	33Ω	±10%	1/4W
SEMICONDUCTORS						
Q1, 3		2SK19 (Y)	RF amplifier	Toshiba (FET)		
Q2		2SC373	AVC amplifier	Toshiba silicon		
Q4		2SK19 (Y)	Mixer	Toshiba (FET)		
Q5, 6		2SC372 (&)	IF amplifier	Toshiba silicon		
Q7		2SC373	AVC amplifier	Toshiba silicon		
Q8		2SK19 (Y)	Local oscillator	Toshiba (FET)		
Q9		2SK37 (H)	BFO	Mitsubishi (FET)		
Q10		2SC373	AM amplifier	Toshiba silicon		
Q11		2SC1173 (C)	Voltage regulator	Toshiba silicon		
IC-1	μPC20C	μPC20C	AF amplifier	NEC IC		
D1, 2		1N60/1N34	RF protector	Germanium		
D3		1N34	Detector	Germanium		
D4		1N34	Noise limiter	Germanium		
D5, 6		1N60/1N34	AVC detector	Germanium		
D7	EQA01-07R	EQA01-07R	Zener diode	7V ± 5%		
D8-11		1N60/1N34	Product detector	Germanium		
D12, 13		S1B0102	Rectifier	Silicon		
D14		S1B0102	DC protector	Silicon		
D15	EQA01-10R T-1148	EQA01-10R M-10K	Zener diode	12V ± 5%		
			Thermistor			
POTENTIOMETERS						
VR1, 2	P-0725		Potentiometer	2kΩ		RF
VR	P-0726		Potentiometer w/SW-11 switch	10kΩ		AF
SWITCHES						
SW1~6	S-1130	GE-18C-4093	Rotary	Band Switch Y-395		
SW7, 8, 9, 10-1/2	S-2202	6P14L	Slide	ANL BFO AVC OPR		

Ref. No.	RS Parts Number	MFR's Parts Number	Description		
VARIABLE CAPACITORS/TRIMMER CAPACITORS					
VC1	C-4469	GE-18D-4083	Ant. Trimmer		
VC7	C-4469	GE-18D-4083	BFO Trimmer		
VC2, 4, 6	C-4467	7MD34X16A	Main Tuning	3 gangs	
VC3, 5	C-4468	GE-18D-4082	Band Spread Tuning	2 gangs	
CT1	CA-4463	EVC-12W30P	RF PC Trimmer	A Band	
CT2	CA-4463	EVC-12W30P	RF PC Trimmer	B Band	
CT3	CA-4463	EVC-12W30P	RF PC Trimmer	C Band	
CT4	CA-4463	EVC-12W30P	RF PC Trimmer	D Band	
CT5	CA-4463	EVC-12W30P	RF PC Trimmer	E Band	
CT6	CA-4464	AT1-6	OSC PC Trimmer	A Band	
CT7	CA-4464	AT1-6	OSC PC Trimmer	B Band	
CT8	CA-4464	AT1-6	OSC PC Trimmer	C Band	
CT9	CA-4464	AT1-6	OSC PC Trimmer	D Band	
CT10	CA-4464	AT1-6	OSC PC Trimmer	E Band	
TRANS./COILS./FILTERS					
T17	CA-7306	YMC-15001	IFT	455 kHz	(WHT)
T18, 20	CA-3008	YMC-15002A	IFT	455 kHz	(YEL)
T19	CA-3007	R1950	BFO		
T21	TA-0417	Y-0136G	Power Trans		
T21		K-2635	Power Trans		
T1, 2	CA-3003	12BNA-066	Antenna		
T3	CA-3004	6PNA-071	Antenna		
T4	CA-3005	6PNA-074	Antenna		
T5	CA-3006	6PNA-077	Antenna		
T6	CA-4470	6PNR-067	RF		
T7	CA-4471	6PNR-069	RF		
T8	CA-4472	6PNR-072	RF		
T9	CA-4473	6PNR-075	RF		
T10	CA-4474	6PNR-078	RF		
T11	CA-4465	6PNO-068	Local OSC		
T12	CA-4466	6PNO-070	Local OSC		
T13	CA-4467	6PNO-073	Local OSC		
T14	CA-4468	6PNO-076	Local OSC		
T15	CA-4469	6PNO-079	Local OSC		
L1		LF1-251	Choke coil	250 μ H	
L2		LF1-470	Choke coil	47 μ H	
T16	CA-3009	MFH-40K	Mechanical filter 455 kHz (RED)		
MISCELLANEOUS					
	Z-1700	GE-15B-2256	Cabinet		
	Z-1701	GE-11C-535A	Bottom Plate		
	Z-1702	GE-17C-3387	Rear Board		
	Z-1703	GE-18C-4068	Front Panel		
	G-0142	GE-18D-4069	Tuning Dial Plate		
	G-0143	GE-18D-4070	Spread Dial Plate		
	D-3115	GE-18D-4072	Tuning Dial Shaft		
	D-3114	GE-18D-4071	Spread Dial Shaft		
	D-3116	GE-12D-728	Dial Spread Shaft		
	HB-0441	GE-11D-617	Spread Sleeve		
	HB-0440	GE-11C-543A	Pulley Stud		

Ref. No	RS Parts Number	MFR's Parts Number	Description	
J1 J2	HB-0442	GE-11C-521A	Chassis	
	RA-3185	GE-11C-575 (1.2)	Rotary Switch Bearing	
	RA-2408	GE-12D-734	Flywheel	
	RA-2409		Pulley 40φ	
	RA-2410		Pulley 70φ	
	G-0144	GE-18C-4084	Pulley 90φ	
	HB-0443	GE-11C-534	Dial Back Panel	
	HB-0444	GE-16D-3333	Sub Panel for Spread Variable Capacitor	
	HB-0445	GE-16D-3333	Side Angle (L)	
	D-1105	GE-12D-722	Side Angle (R)	
	D-1106	GE-12C-725	Dial Pointer for Main Tuning	
	HB-0446	GE-11C-609	Dial Pointer for Spread Tuning	
		GE-16B-3327	Shield Bar	
	X-4682	GE-18D-3966	Main PC Board UL listed	
	M-0233	4121DS	Coil Pack PC Board UL listed	
	F-1092	SN-2055	S. Meter	
	J-0567	No. 1476	Fuse Holder UL, CSA listed	
	J-6236	No. 3822	3P Power Connector	
	KJ-4327	3-210	2 Pin Lug & Socket	
	J-0568	L-J079	3P Screws Terminal	
	J-0569	L-J047	Phones Jack	
	HB-0447	GE-12-758	Speaker Jack	
	HB-0448	No. 4108	Cord Binder	
	HB-0449		Lamp Grommet	
	HB-0450		Grommet 10φ	
	F-0139	No. 4850-20	Antenna Holder	
	HF-0079		Plastic Foot	
	HB-0453		Fuse 0.5A Cartridge Type	
	HB-0452		Nuts & Screws 1 kit	
	L-0470		Wires	
	L-0471		Lead Lamp L=90m/m 7V 50mA	
	W-1670		Lead Lamp L=440m/m 7V 50mA	
	W-1671		Line Cord UL Listed BLK-6 Feet	
	HB-0451	SR-3P-4	DC Plug with Cord/Fuseholder	
			Line Cord Strain Relief UL Listed	
			Dial String 0.7φ 2.1 meter	
			Dial Spring 9L	
			Dial Spring 5L	
		5003	Nylon Pulley	
		GE-18D-4073	Knob Main Tuning/Spread	
		GE-18D-4074	Knob VOL. RF. BAND. ANT TRIM. BFO TRIM	
			Terminal Strip 1L1P UL Type	
			Terminal Strip 1L1P for sub panel	
	SPEAKER BOX			
		S-4478		Speaker
		Z-1704		Speaker Box
		Z-1705		Box Rear Plate
	Z-1706		Front Panel	
			Plug with Cord	
	HB-0455		Screws 1 kit	

SCHEMATIC DIAGRAM

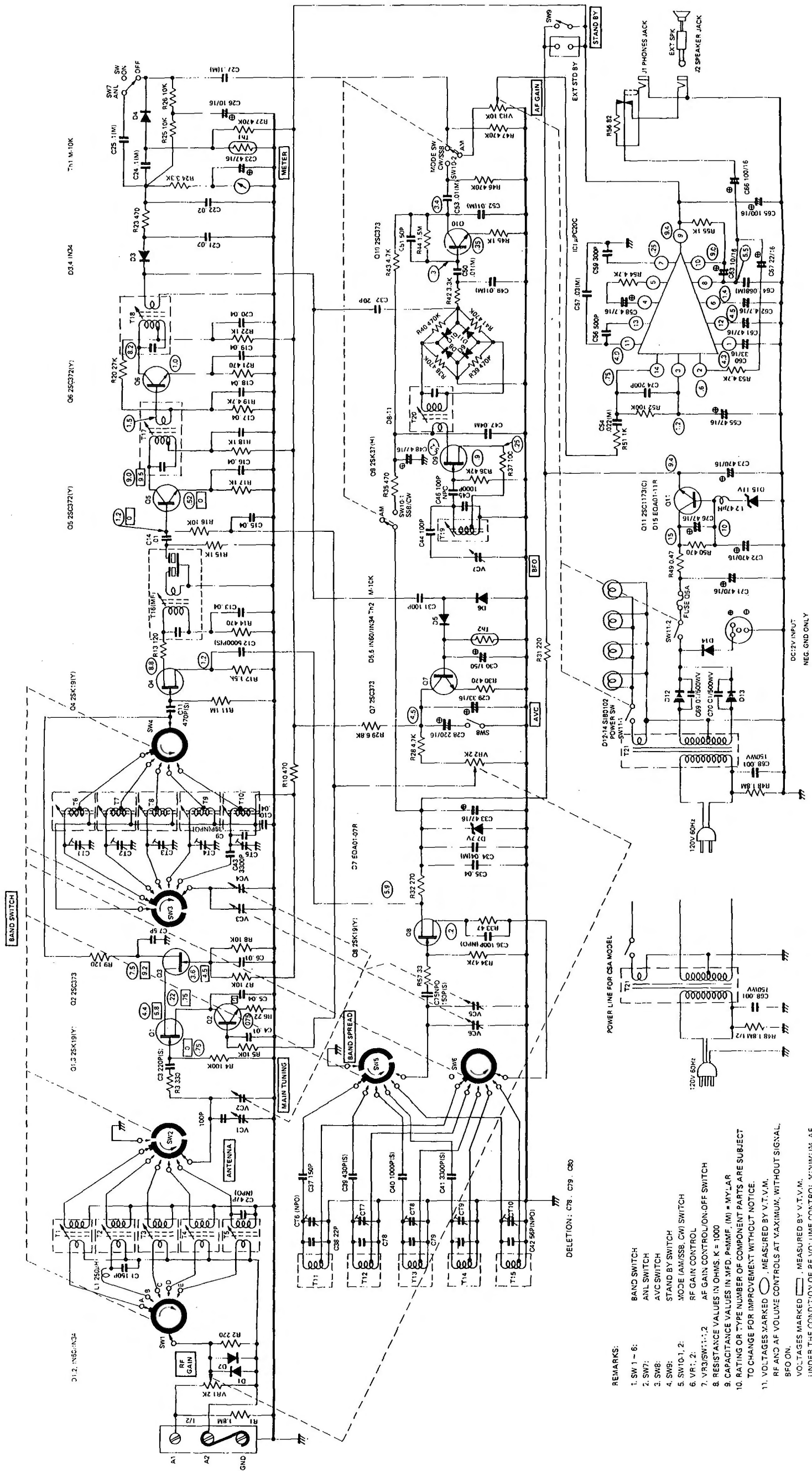

- REMARKS:
- SW 1 - 6: BAND SWITCH
 - SW 7: ANT. SWITCH
 - SW 8: AVC SWITCH
 - SW 9: STAND BY SWITCH
 - SW 10, 1, 2: MODE (AM/SSB, CW) SWITCH
 - VR 1, 2: RF GAIN CONTROL
 - VR 3/SW 11, 1, 2: AF GAIN CONTROL/ON-OFF SWITCH
 - RESISTANCE VALUES IN Ω, MFD., P-IMP., (M) = MΩ, L, R
 - CAPACITANCE VALUES IN MFD., P-IMP., (M) = MΩ, L, R
 - RATING OR TYPE NUMBER OF COMPONENT PARTS ARE SUBJECT TO CHANGE FOR IMPROVEMENT WITHOUT NOTICE.
 - VOLTAGES MARKED ○: MEASURED BY V.T.V.M.
 - RF AND AF VOLUME CONTROLS AT MAXIMUM, WITHOUT SIGNAL, BFO ON.
 - VOLTAGES MARKED □: MEASURED BY V.T.V.M.
 - UNDER THE CONDITION OF RF VOLUME CONTROL MINIMUM, AF VOLUME CONTROL AT MINIMUM, WITHOUT SIGNAL, BFO ON.

DELETION: C78, C79, C80