

SERVICE MANUAL

PARTS LIST

MODEL GXC-730D

AKAI

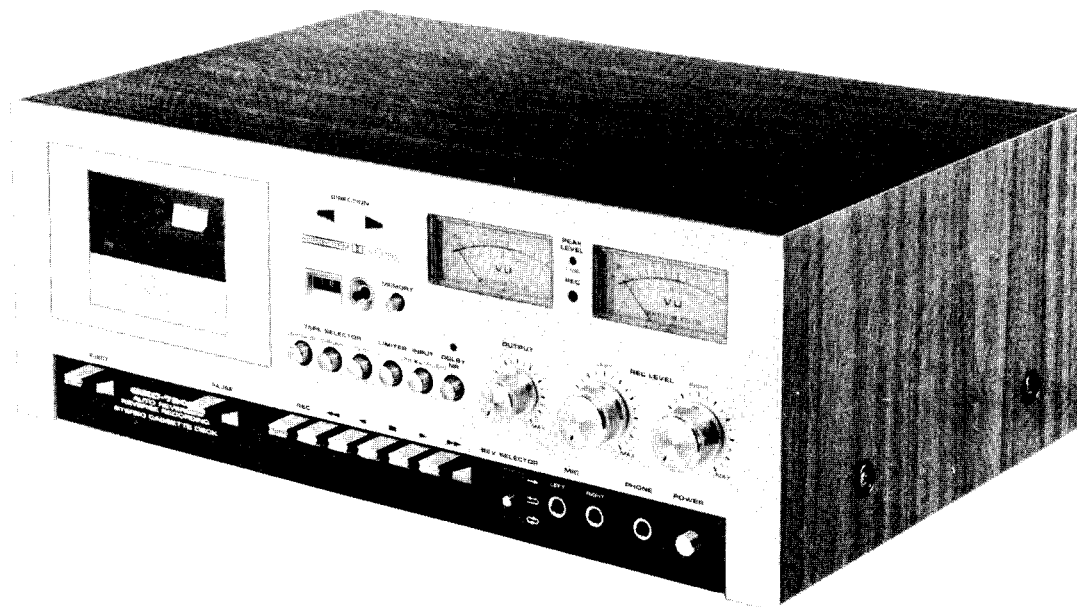

AKAI CASSETTE DECK

MODEL GXC-730D

SECTION 1	SERVICE MANUAL	1
SECTION 2	PARTS LIST	33
SECTION 3	SCHEMATIC DIAGRAM	56

SECTION 1

SERVICE MANUAL

TABLE OF CONTENTS

I.	TECHNICAL DATA	2
II.	DISMANTLING OF UNIT	3
III.	CONTROLS	4
IV.	PRINCIPAL PARTS LOCATION	5
V.	CIRCUIT OPERATION	6
	1. SYSTEM CONTROL (SYSCON) OPERATION	6
	2. AUTOMATIC STOP OPERATION	11
	3. REV MODE SELECTOR OPERATIONS	13
	4. MEMORY OPERATIONS	13
VI.	MECHANISM ADJUSTMENT	15
	1. PLAY SOLENOID INSTALLATION POSITION ADJUSTMENT ...	15
	2. REVERSE SOLENOID INSTALLATION POSITION ADJUSTMENT	15
	3. FW WHEEL INSTALLATION POSITION ADJUSTMENT	16
	4. PINCH ROLLER AND CAPSTAN GAP ADJUSTMENT	16
	5. CAPSTAN SHAFT LOOSE PLAY ADJUSTMENT	17
VII.	HEAD ADJUSTMENT	18
VIII.	AMPLIFIER ADJUSTMENT	20
IX.	DC RESISTANCE OF VARIOUS COILS	23
X.	CLASSIFICATION OF VARIOUS P.C BOARDS	23
	1. RELATION OF P.C BOARD TITLE AND IDENTIFICATION NUMBER	23
	2. COMPOSITION OF VARIOUS P.C BOARDS	24

For basic adjustments, measuring methods, and operating principles, refer to GENERAL OPERATING PRINCIPLES AND ADJUSTMENTS.

II. DISMANTLING OF UNIT

In case of trouble, etc. necessitating disassembly, please disassemble in the order shown in photographs. Reassemble in reverse order.

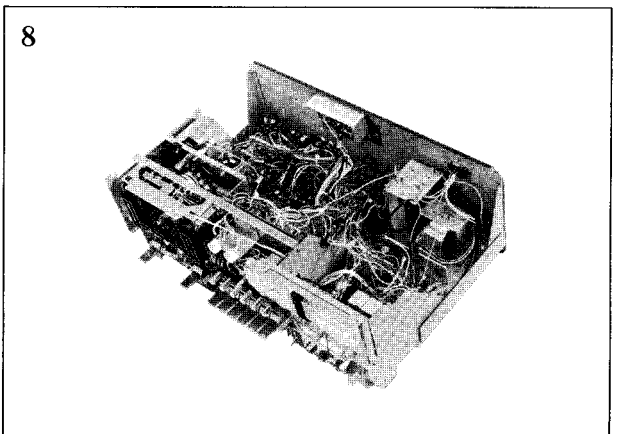
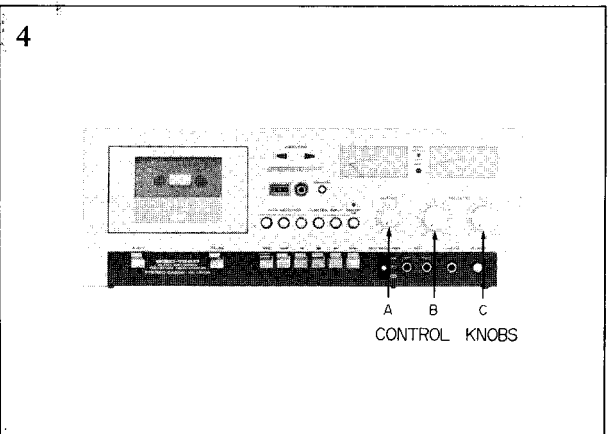
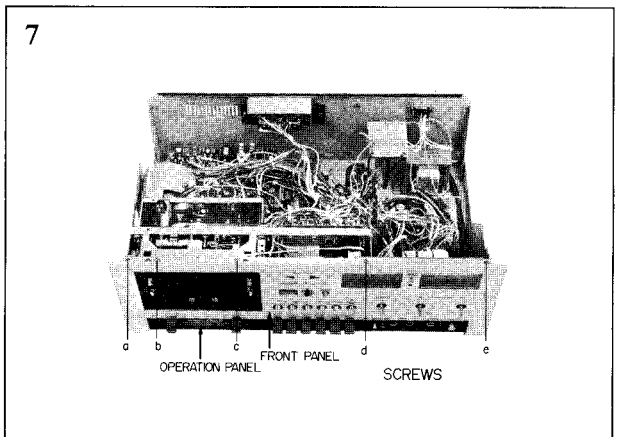
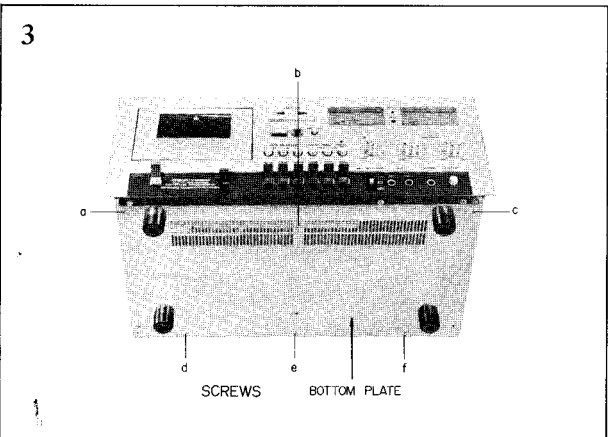
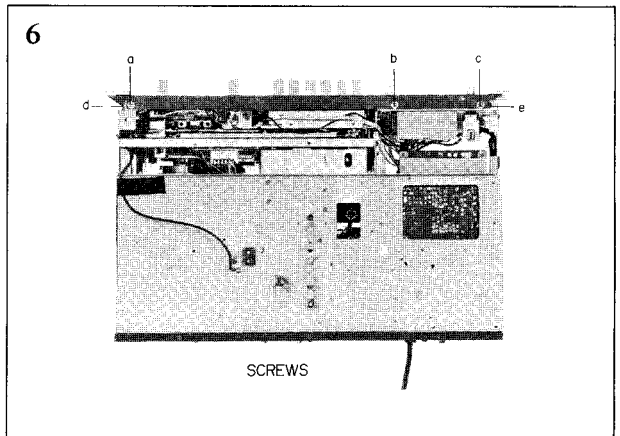
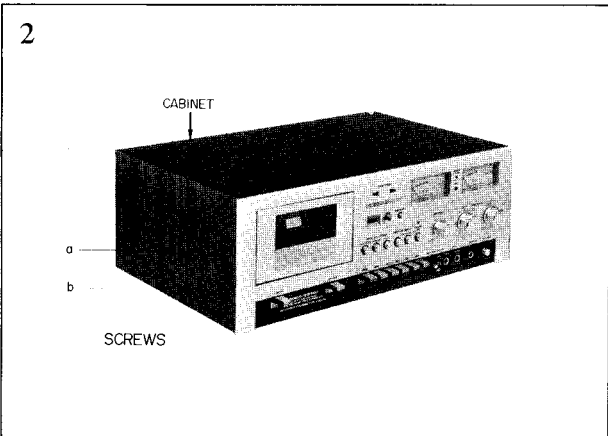
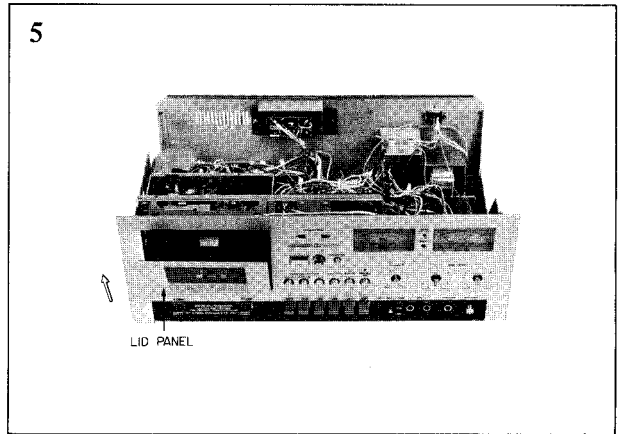
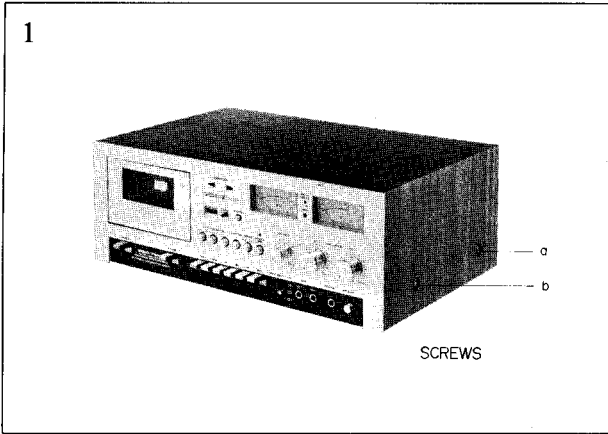

III. CONTROLS

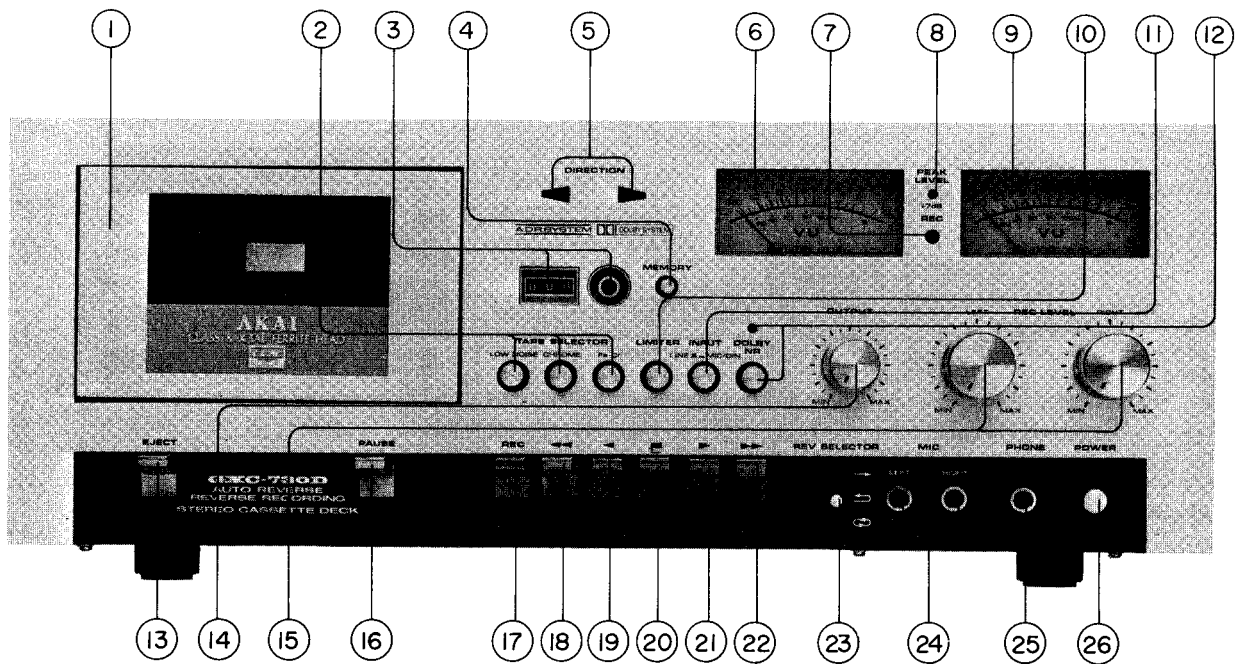

Fig. 1 Controls

- | | |
|--|---|
| 1. CASSETTE RECEPTACLE LID (with tape view window) | 14. OUTPUT LEVEL CONTROL |
| 2. TAPE SELECTOR SWITCHES | 15. RECORDING LEVEL CONTROLS (Left and right) |
| 3. INDEX COUNTER AND RESET BUTTON | 16. PAUSE KEY |
| 4. MEMORY WIND BUTTON | 17. RECORDING KEY |
| 5. DIRECTION INDICATOR LAMPS | 18. REWIND ◀◀ KEY |
| 6. LEFT VU METER | 19. REVERSE PLAY ◀ KEY |
| 7. RECORDING INDICATOR LAMP | 20. STOP ▶ KEY |
| 8. PEAK LEVEL INDICATOR | 21. FORWARD PLAY ▶▶ KEY |
| 9. RIGHT VU METER | 22. FAST FORWARD ▶▶▶ KEY |
| 10. LIMITER SWITCH | 23. REVERSE SELECTOR |
| 11. INPUT SELECTOR | 24. MICROPHONE JACKS (Left and Right) |
| 12. DOLBY N.R. SWITCH AND INDICATOR LAMP | 25. HEADPHONE JACK |
| 13. EJECT KEY | 26. POWER SWITCH |

IV. PRINCIPAL PARTS LOCATION

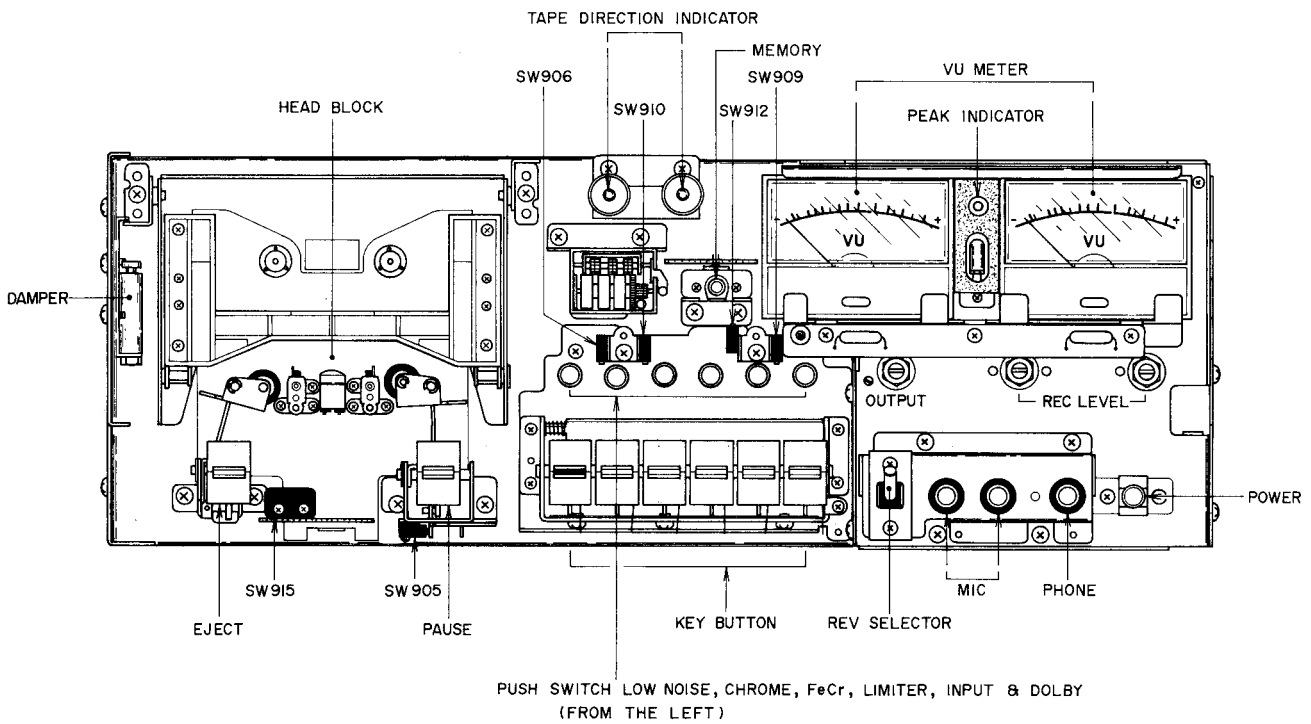

Fig. 2 Front View

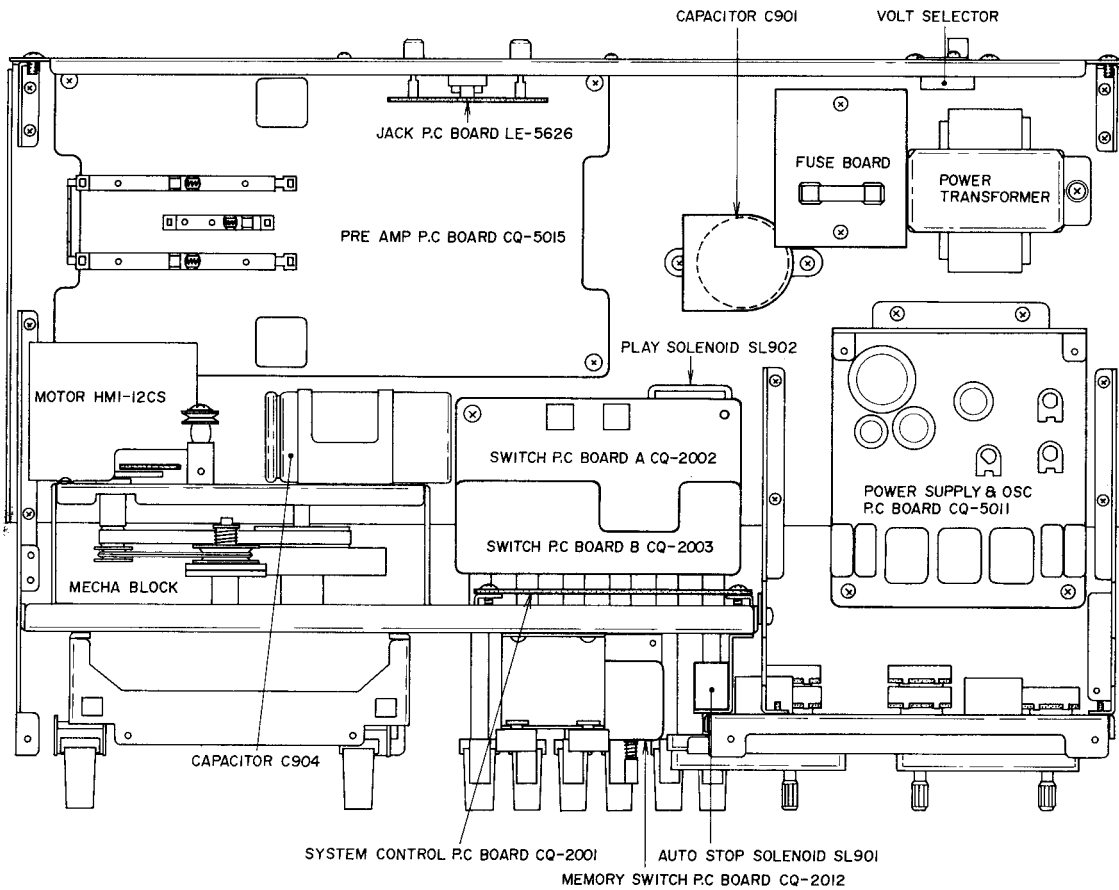
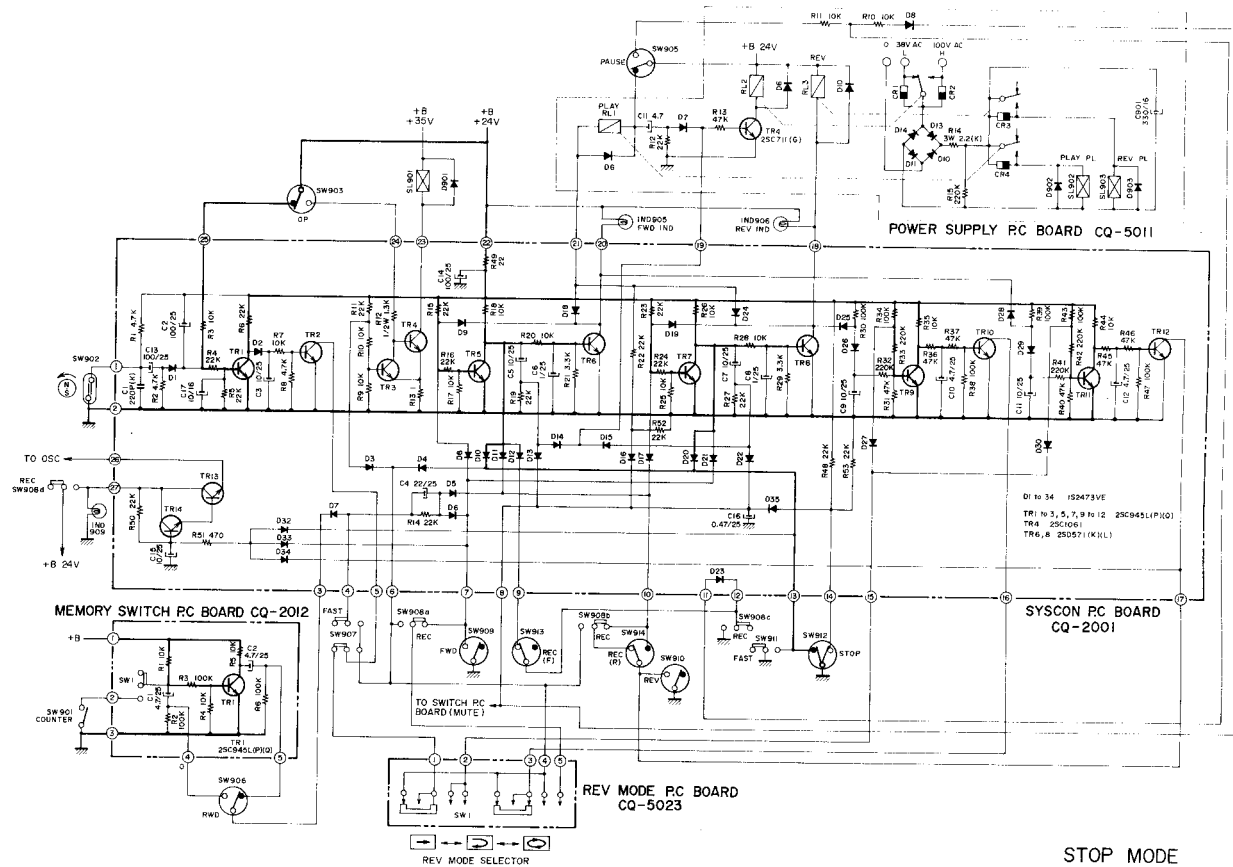

Fig. 3 Top View

V. CIRCUIT OPERATION

1. SYSTEM CONTROL (SYSCON) OPERATION



STOP MODE
SCHEMATIC-1

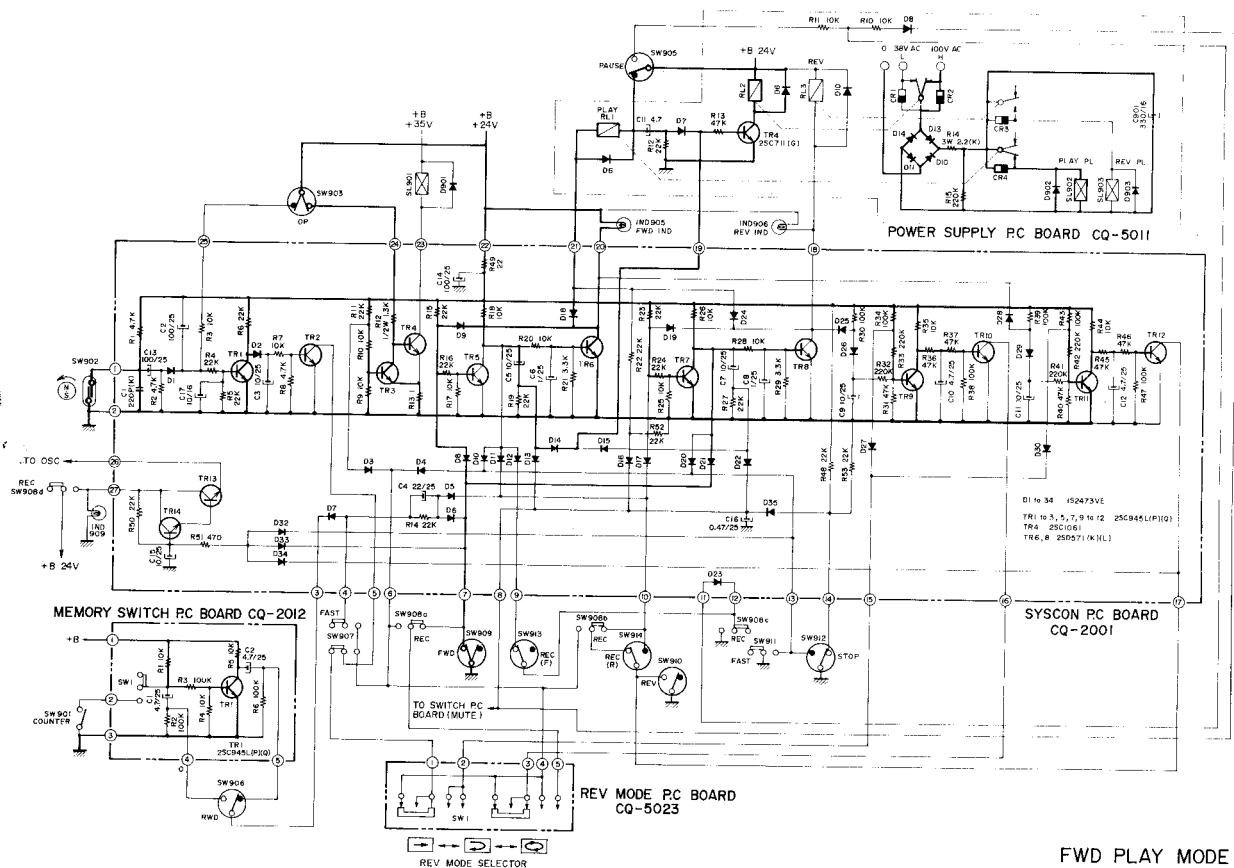

FWD PLAY MODE
SCHEMATIC-2

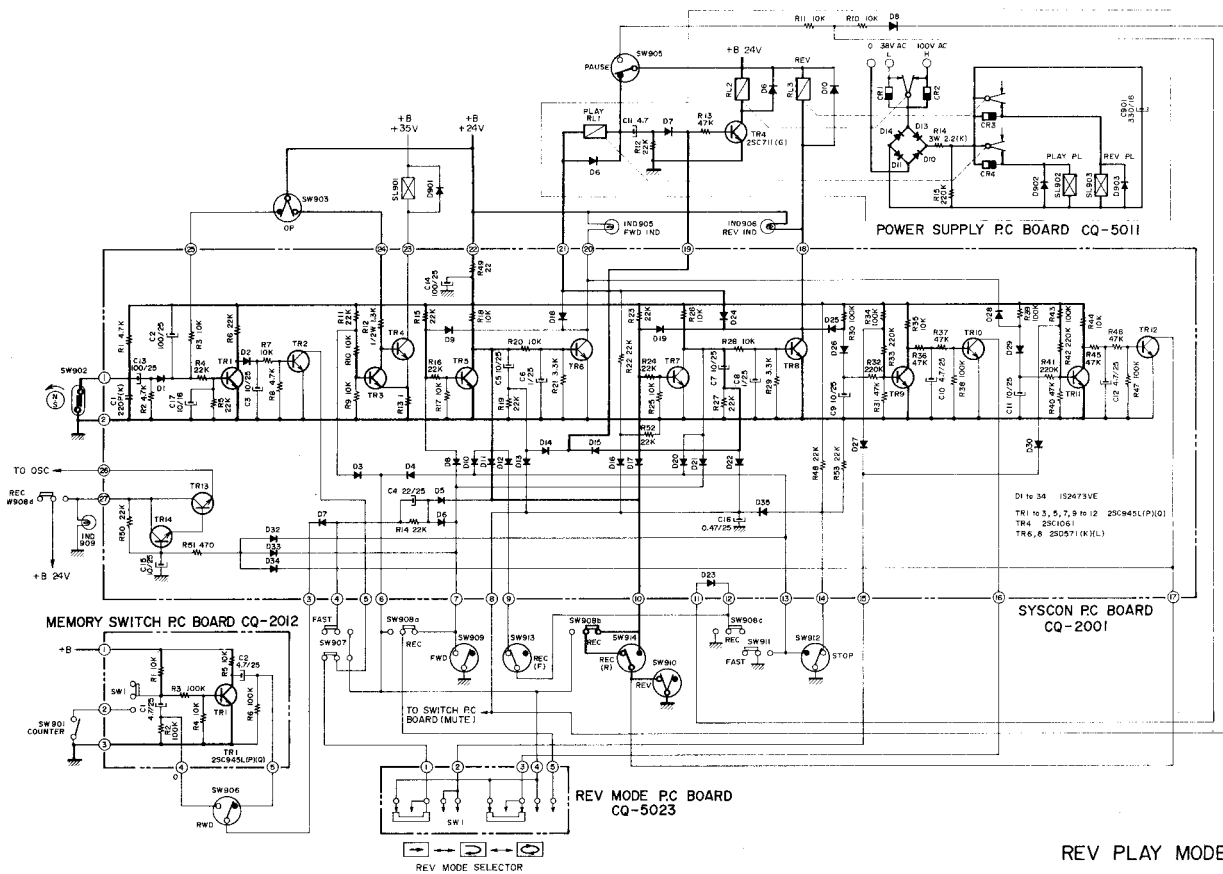

1) Forward Playback (Refer to SCHEMATIC-2)

- a) When FWD key is depressed, FWD Switch (SW909) is grounded, TR5 base electric potential decreases and TR5 turns OFF. Base bias is supplied to TR6 through R18 and R20, and TR6 is turned ON.
- b) Immediately after the FWD button is depressed and SW909 is turned ON, SW909 returns to OFF condition. In order to hold TR6 at ON condition, TR5 base bias is supplied through D9 and TR6 and decreased to approximately the ground electric potential.
- c) Accordingly, FWD IND LAMP (IND 905) and RL1 operate because TR6 is ON. And because bias is supplied to TR4 base through C5, D14 (SYSCON P.C BOARD), and R13 (POWER SUPPLY P.C BOARD), TR4 is turned ON and RL2 operates.
- d) Also, until C5 is charged, a lead-in high voltage is supplied to the Play Plunger (SL902) and Play Plunger operates putting the deck into a FWD Playback mode.
- e) After C5 is charged, bias is not supplied to TR4 (POWER SUPPLY P.C BOARD) so that TR4 turns OFF and RL2 stops. Low voltage to hold is then supplied to Play Plunger (SL902) to maintain the FWD Playback mode.

2) Reverse Playback (Refer to SCHEMATIC-3)

- a) By depressing the REV button, REV switch (SW910) is turned ON and TR7 base bias is decreased to about the same electric potential as ground so that TR7 is turned OFF. When TR7 is at OFF condition, TR7 collector voltage increases and base bias is supplied to TR8 through R26 and R28. TR8 is then turned ON.
- b) When TR8 is turned ON, REV IND LAMP (IND 906) and RL3 operate, and by the flow of the electric current through D24 and TR8, RL1 is turned ON.
- c) Of the circuits R13 (POWER SUPPLY P.C BOARD), D15 and C7 (SYSCON P.C BOARD), TR4 is turned ON and RL2 operates only during the charging time of C7.
- d) Accordingly, REV Playback mode is achieved by RL1, RL2, and RL3 operation through the workings of Play Plunger (SL902) and REV Plunger (SL903).
- e) SW910 returns to OFF immediately after the REV button is depressed. In order to hold TR8 at ON, TR7 base bias is decreased to near ground electric potential through R23 and D14.

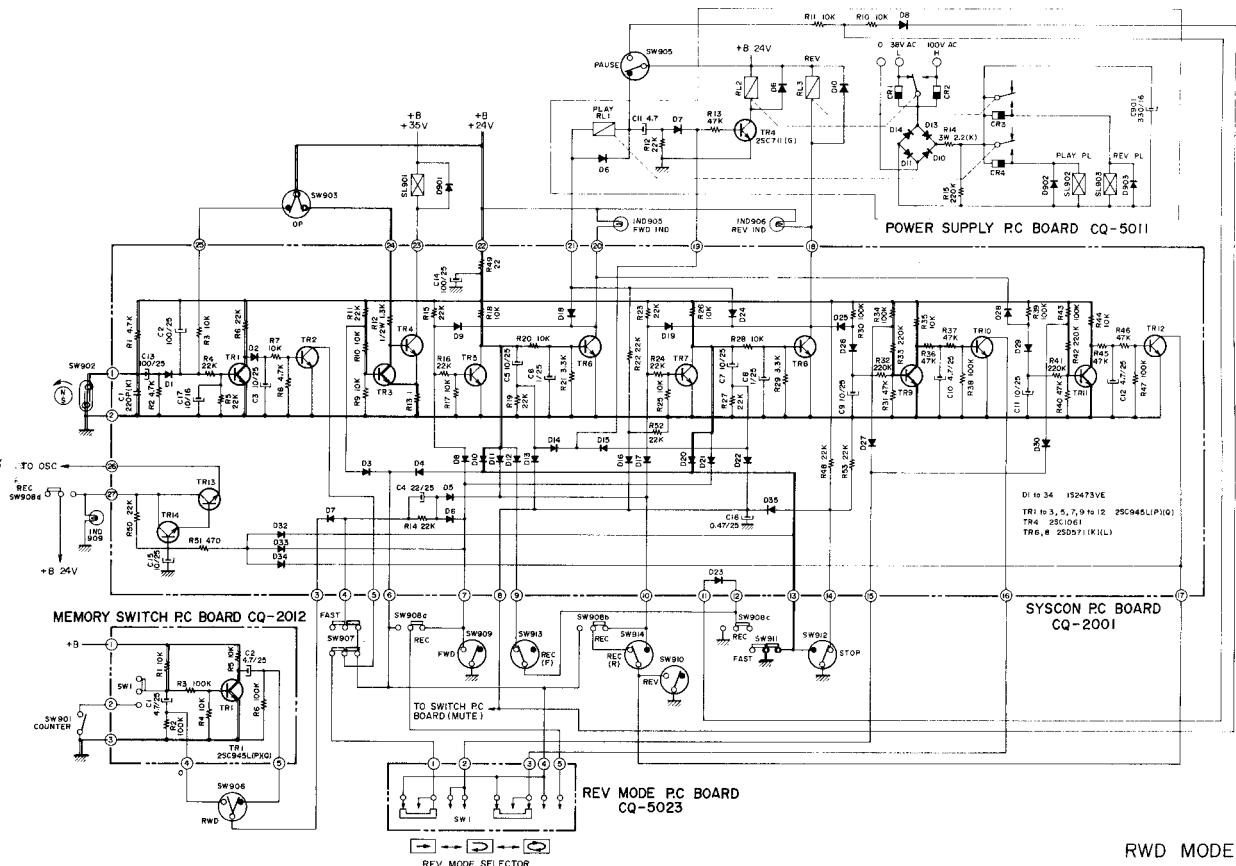
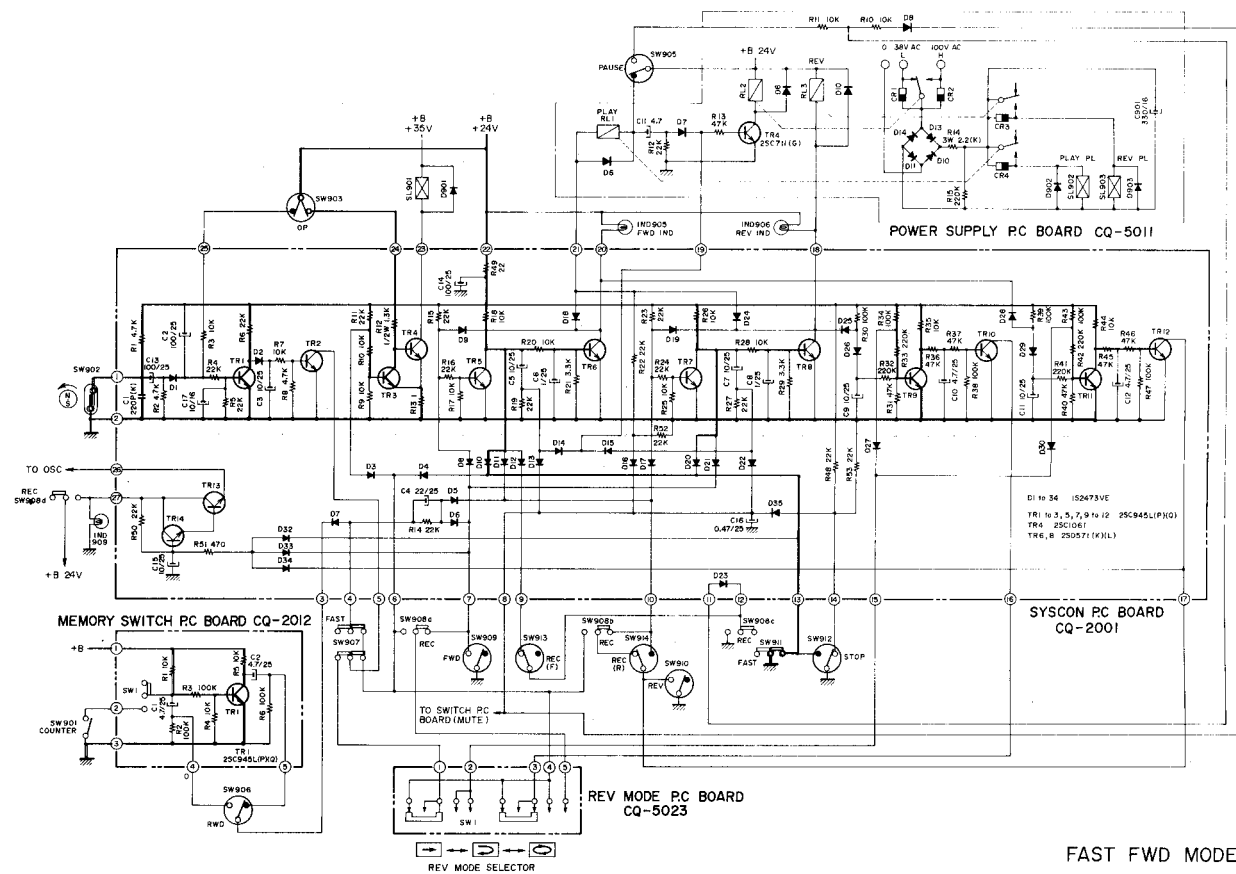

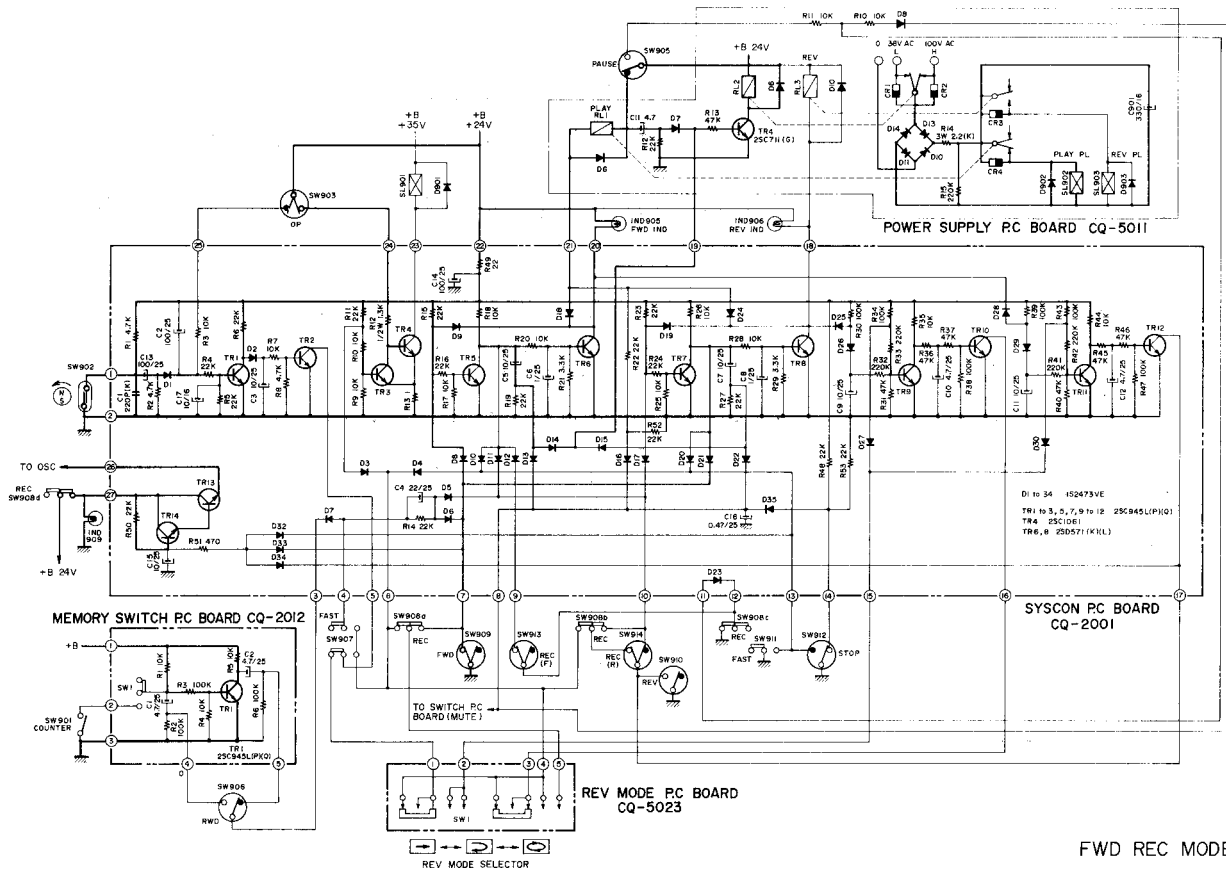

SCHEMATIC-6

3) Fast Forward and Rewind

(Refer to SCHEMATIC-4, 5)

- a) Fast forward and rewind modes are mostly mechanically operated.
- b) Bias is supplied to TR1 base through D1 and R4 by charge/discharge of C13 and TR1 is thereby turned ON. On the other hand, TR2 base electric potential is decreased to near ground electric potential through TR1 and is turned OFF.
- c) Because SW903 is turned ON, voltage is regularly supplied to TR3 base through R10 and R11, and TR3 is turned ON. Consequently, TR4 base electric potential is decreased to near ground electric potential, TR4 is turned OFF, and Stop Plunger maintains OFF condition.
- d) Since TR6 and TR8 base electric potentials are decreased to near ground electric potential because SW911 is ON, TR6 and TR8 is turned OFF, and RELAY, PLUNGER, etc. maintains OFF condition.

4) Forward REC (Refer to SCHEMATIC-6)

- a) When Rec and Forward keys are depressed (SW903, SW909, SW913, SW914, SW908 a,b,c, and d are ON), REC LAMP (IND 909), TR13 and TR14 are turned ON due to SW908d and +B is supplied to the OSC circuit to start OSC circuit operation.
- b) Since Forward key is also depressed, items 1) to 5) under Forward Play condition is also achieved to bring the deck into FORWARD REC MODE.

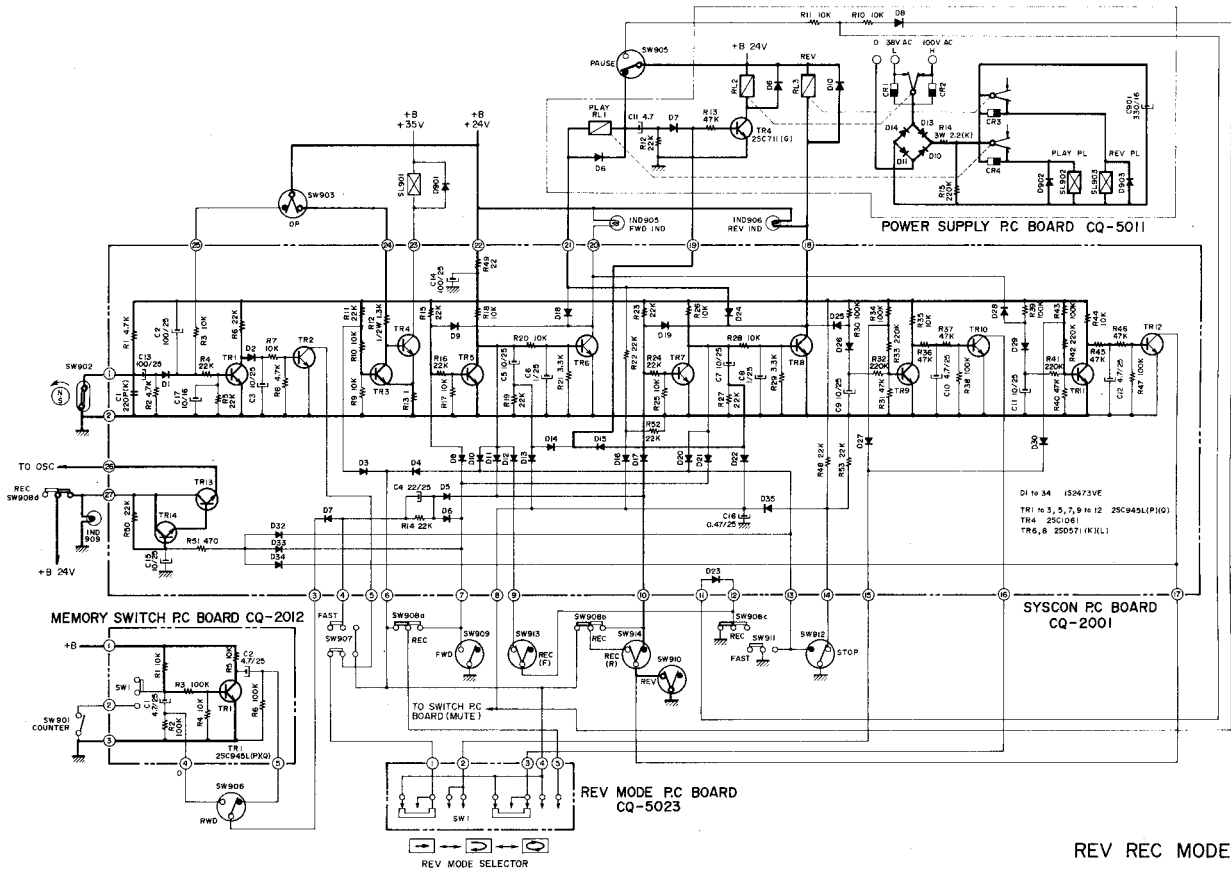

REV REC MODE
SCHEMATIC-7

5) Reverse REC (Refer to SCHEMATIC-7)

- a) When Rec and Reverse keys are depressed, SW903, SW910, SW913, SW914, SW908 a,b,c and d are turned ON. Rec LAMP (IND 909), TR13, and TR14 are turned ON when SW908d is turned ON and +B is supplied to OSC circuit to operate OSC circuit.
- b) At the same time, REV key is depressed so that the conditions in items a) to e) under REV Play occurs simultaneously to achieve REV REC MODE.

2. AUTOMATIC STOP OPERATION

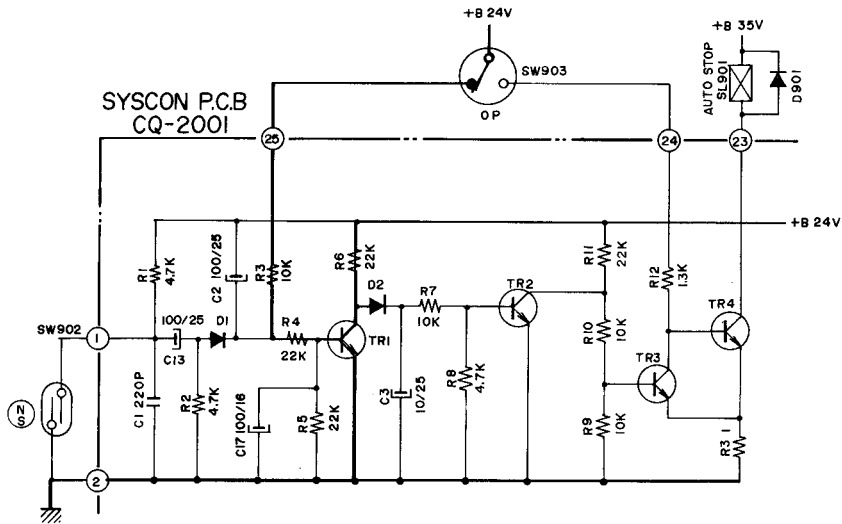

SCHMATIC-8

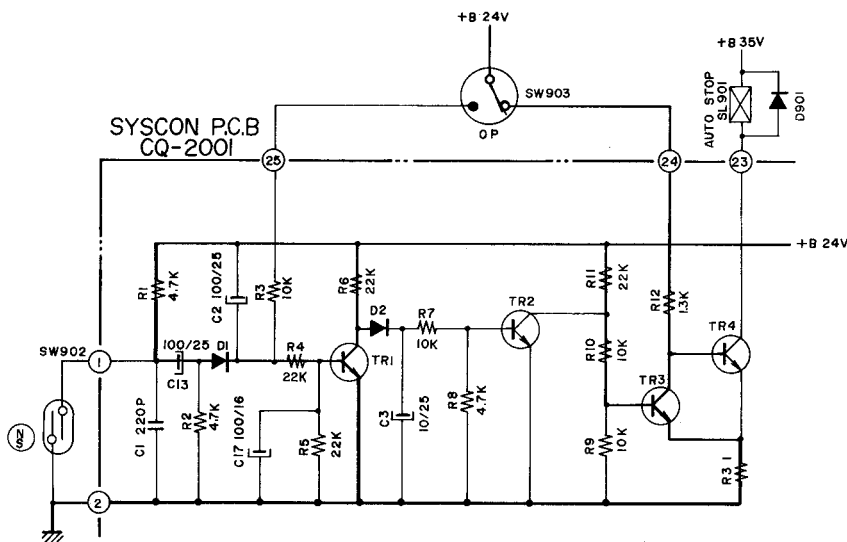

SCHMATIC-9

1) During Tape Travel (Refer to SCHEMATIC-9)

- a) When tape is traveling (condition at which tape counter rotates), the magnet rotates and the Reed switch is at ON-OFF condition.
- b) When the Reed switch is turned ON and OFF, C13 is repeatedly charged/discharged and the AC signal is generated on the anode side of D1. This AC signal is rectified at D1 and smoothed at C2 and becomes the base bias of TR1.

- c) Accordingly, TR1 maintains ON condition, and TR2 turns OFF because TR2 base is inverse biased through D2.
- d) Also, TR3 is turned ON by a supply of forward bias, and TR4 base electric potential is decreased through TR3. Since this maintains OFF condition, STOP PLUNGER (SL901) does not operate.

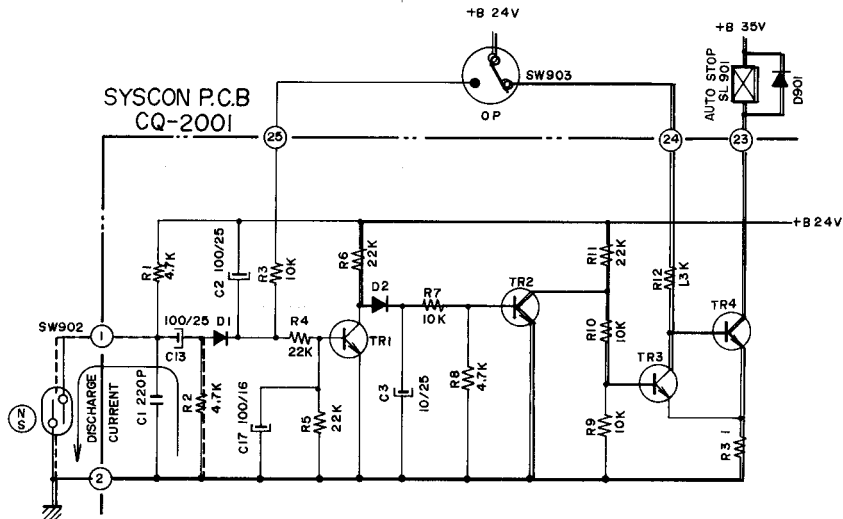

SCHEMATIC-10

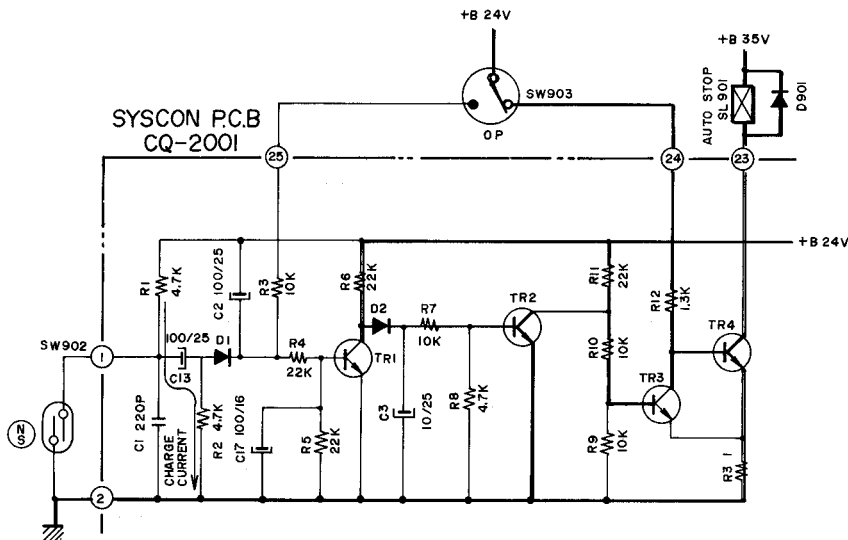

SCHEMATIC-11

2) When Tape Travel Stops with Reed switch ON
(Refer to SCHEMATIC-10)

- a) When the tape travel is stopped with the Reed switch at ON condition, the electric charge charged at C13 is discharged through Reed switch and R2.
- b) Accordingly TR1 is turned OFF because the AC signal generated on the anode side of D1 stops. When TR1 is turned OFF, TR1 collector electric potential increases and bias is supplied to TR2 to turn ON TR2.
- c) When TR2 is turned ON, TR3 base electric potential decreases and TR3 is turned OFF. At the same time, base bias is supplied to TR4 and TR4 is turned ON.
- d) Because TR4 is turned ON, STOP PLUNGER (SL901) operates and STOP mode is effected.
- e) By the STOP PLUNGER operation, SW903 is turned OFF. This causes flow of base bias to

TR1 through SW903, R3 and R4 and subsequently TR is turned ON.

- f) As a result, TR1 is turned ON and TR2, TR3, and TR4 are turned OFF as shown in SCHEMATIC-10. STOP PLUNGER is thereby released. (The release occurs in extremely short period.)

3) When Tape Travel Stops with Reed Switch OFF
(Refer to SCHEMATIC-11)

- a) When the tape travel is stopped with the Reed Switch at OFF condition, charge current begins to flow through R1→C13→R2 to C13.
- b) While charge current is flowing to C13, voltage is generated on both sides of R2. But when charging of C13 is completed, voltage is not generated.
- c) Same as Item 2) b) to f).

3. REV MODE SELECTOR OPERATIONS

(Refer to SCHEMATIC-2, 3)

1) ONE-WAY (FWD OR REV) PLAYBACK MODE

() OPERATION

- a) In the  mode, terminals ① ③ ④ on REV MODE P.C BOARD (CQ-5023) are connected.
- b) When the tape stops at the end, TR1 is turned OFF because bias is not supplied to TR1 base. At the same time, due to the increase of TR1 collector voltage, base bias is supplied to TR2 and TR2 is turned ON.
- c) When TR2 is turned ON, TR3 base bias is decreased to about the same electric potential as ground through R1, D3 and TR2, and thereby TR3 is turned OFF. Accordingly, TR3 collector voltage increases, base bias is supplied to TR4, and TR4 is turned ON.
- d) Stop Plunger (SL901) operates and AUTOMATIC STOP is effected when TR4 is turned ON.

2) ONE CYCLE FWD OR PLAYBACK MODE

() OPERATION





- a) In the  mode, REV MODE P.C BOARD (CQ-5023) terminals from ① and ② are connected as well as from ③ and ④.
- b) When the tape stops after FWD PLAYBACK, TR1 is turned OFF because bias is not supplied to TR1 base. At the same time, due to the increase of TR1 collector voltage, base bias is supplied to TR2 and TR2 is turned ON.
- c) When TR2 is turned ON, TR11 base bias is decreased to about the same electric potential as ground through R43, D30, and TR2 as well as through R39, D28, and TR6. This turns TR11 OFF. TR12 is then turned ON because base bias is supplied to TR12 through R45 and R46 when TR11 is turned OFF.
- d) TR7 is turned OFF because TR7 base bias is decreased to near ground electric potential by means of R23, D17, SW908b, and TR12 when TR12 is turned ON. Then a base bias is supplied to TR8 through R29 and R28, and TR8 is turned ON. Likewise, TR6 is turned OFF because TR6 base bias is decreased to near ground electric potential by means of R18, D11 SW908b, and TR12 when TR12 is turned on. This release FWD PLAY mode.
- e) Since TR8 is turned ON, REV PLUNGER operates and REV PLAY starts.
- f) When the tape stops at the end of REV PLAY, TR1 is turned OFF because base bias supply to TR1 is stopped and TR2 is turned ON because base bias is supplied to TR2.
- g) TR9 base bias is decreased to about the same electric potential as ground through R34, D27, and TR2 as well as R30, D25, and TR8 when TR2 is turned ON. As a result, TR9 is turned OFF. On the other hand, base bias is supplied to TR10 through R35, R36, and R37, and

TR10 is turned ON.

- h) When TR10 is turned ON, TR3 base bias is decreased to near ground electric potential through R11, D3, and TR10. As a result TR3 is turned OFF and TR4 is turned ON. Stop Plunger (SL901) operates and STOP mode is effected when TR4 is turned ON.

3) CONTINUOUS PLAYBACK MODE

() OPERATION

- a) In the  mode, REV MODE P.C BOARD (CQ-5023) terminals from ① and ② are connected as well as from ③ and ⑤.
- b) Because REV MODE P.C BOARD (CQ-5023) terminal ④ is OPEN, base bias is continuously supplied to TR3. Therefore, TR3 and TR4 are always ON and, thus, STOP PLUNGER does not operate in the  mode.
- c) The operation as deck changes from FWD to REV and until the end of REV condition is the same as the operation described in items b) to g) under  mode.
- d) When TR10 is turned ON, TR8 base bias is decreased to about the same electric potential as ground through R26, D21, and SW908a. So TR8 is turned OFF and REV PLAY stops.
- e) TR5 base bias is also decreased to near ground electric potential through R15, D8, SW908a, and TR10, and TR5 is turned OFF when TR10 is turned ON. At the same time, base bias is supplied to TR6 through R18 and R20, and TR6 is turned ON. FWD PLAY starts.
- f) Therefore, when REV MODE P.C BOARD SWITCH SW1 is set to , continuous PLAY: FWD→REV→FWD can be accomplished.

4. MEMORY OPERATION

The tape counter includes a switch that makes contact when the tape counter indicator reaches "900" and separates when the indicator reaches "000". The deck can automatically enter STOP mode from Fast Forward or Rewind. If FF and REV keys are depressed together, the deck can enter REV mode from Fast forward. If Rewind and Forward keys are depressed together the deck can enter Forward mode from Rewind.

1) Fast Forward→STOP Operation

(Refer to SCHEMATIC-1, 4)

- a) When the tape counter indicator reaches "900" during Fast Forward mode, the switch (SW901) within the tape counter is turned ON, and TR1 is turned OFF because TR1 base bias is decreased to near ground electric potential through SW901.
- b) Accordingly, TR1 collector voltage increases and electric charge current starts to flow to C2 through R5. (C2 is charged in extremely short period).

- c) The switch (SW901) within the tape counter turns OFF at the moment the counter indicator reaches "000" during Fast Forward.
- d) As SW901 is turned OFF, charge current starts to flow into C1 and completes its charge in a short period. The electric potential between C1 and R1 increases, bias is supplied to TR1 base, and TR1 is turned ON.
- e) At the instant TR1 is turned ON, the electric charge that was charged to C1 during the time TR1 was OFF starts to discharge through TR1 and R6.
- f) Accordingly, the electric potential between C2 and R6 decreases and as the anode sides of D3 and D7 (SYSCON P.C BOARD) are minus biased, TR3 is turned OFF and TR4 is turned ON so that the STOP PLUNGER operates.
- g) The Fast Forward key lock is released when the Stop Plunger operates and the deck goes into a STOP mode.

Reverse key mechanically when the stop plunger operates. Therefore, REV Play can be effected from Fast Forward mode.

2) Rewind→Stop Operation

(Refer to SCHEMATIC-1, 5)

- a) In the Rewind mode, C1 is charged through R1→C1→R2 and TR1 is turned ON because base bias is supplied to TR1 through R1→R3.
- b) At the moment the tape counter indicator decreases to "000" as rewind takes place and reaches "999", the switch (SW901) within the tape counter makes contact and the electric charge charged to C1 starts to discharge through R2.
- c) When discharge begins at C1, the voltage between C1 and R2 gradually decreases, the anode sides of D3 and D7 (SYSCON P.C BOARD) are minus biased, and TR3 (SYSCON P.C BOARD) is turned OFF. TR4 (SYSCON P.C BOARD) is then turned ON and STOP PLUNGER operates.
- d) The rewind key lock is released when STOP PLUNGER operates and the deck goes into a STOP mode.

3) Rewind→Forward Play Operation

(Refer to SCHEMATIC-2, 5)

- a) Same as Rewind→Stop operation 1) to 6).
- b) In Rewind→Forward Play operation, since Rewind and Forward keys are both depressed, Rewind key is released before Forward key mechanically when Stop Plunger operates. Therefore, Forward Play can be effected from Rewind mode.

4) Fast Forward→Reverse Play Operation

(Refer to SCHEMATIC-3, 4)

- a) Same as Fast Forward→Stop Operation 1) to 3).
- b) In Fast Forward→Reverse Play Operation, since Fast Forward and Reverse keys are both depressed, Rewind key is released before

RTV servis Horvat

Kešinci, 31402 Semeljci

Tel : 031-856-637

Tel / fax : 031-856-139

Mob : 098-788-319

rtv-servis-horvat@os.tel.hr

VI. MECHANISM ADJUSTMENT

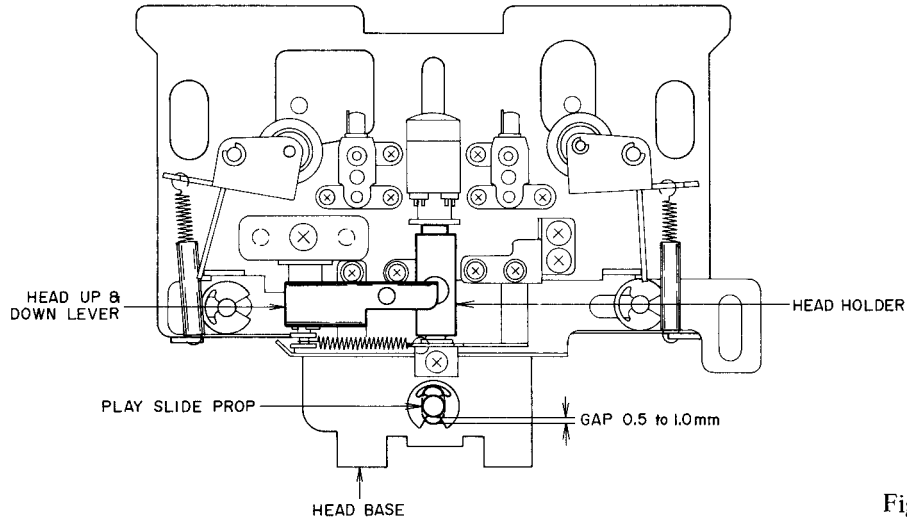

Fig. 4

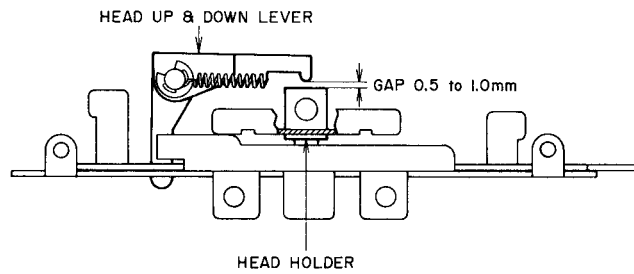

Fig. 5

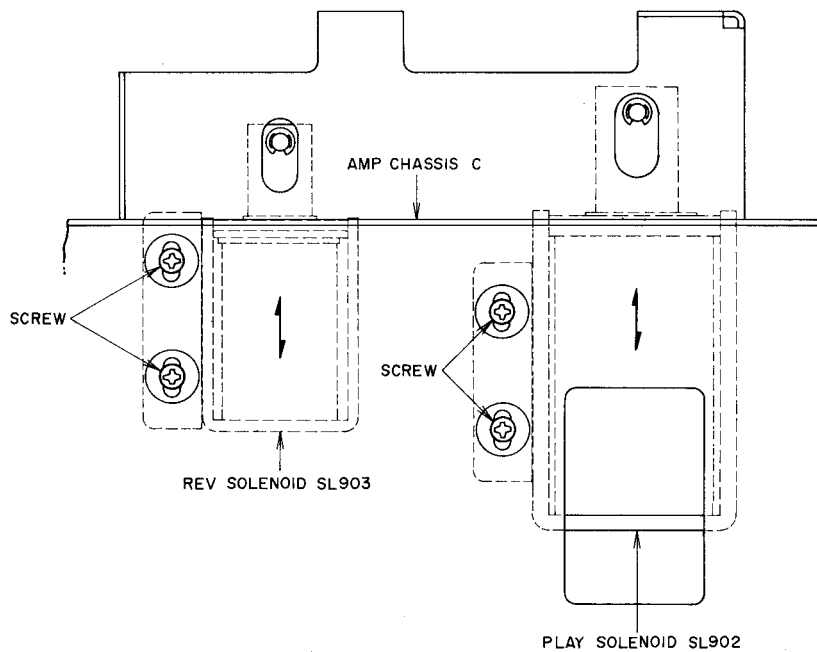

Fig. 6

1. PLAY SOLENOID INSTALLATION POSITION ADJUSTMENT

(Refer to Figs. 4, 5)

Set deck to playback mode and adjust position of play solenoid (SL902) shown in Fig. 5 so that the gap between the oval hole and play slide prop is 0.5 to 1.0 mm as shown in Fig. 4.

2. REVERSE SOLENOID INSTALLATION POSITION ADJUSTMENT

(Refer to Figs. 5, 6)

Set deck to reverse playback mode and adjust position of reverse solenoid (SL903) shown in Fig. 5 so that the gap between the head up and down lever and head holder is 0.5 to 1.0 mm as shown in Fig. 5.

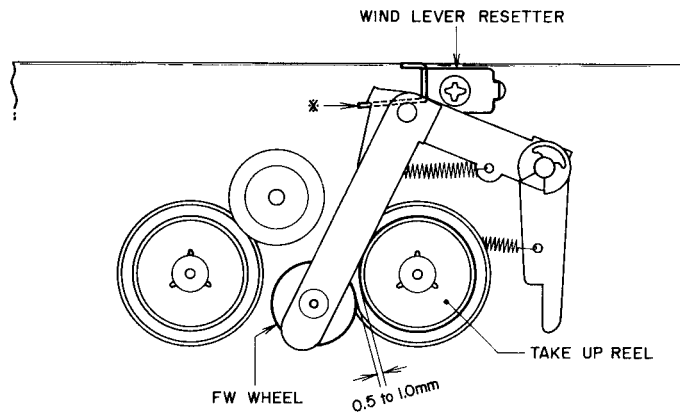

Fig. 7

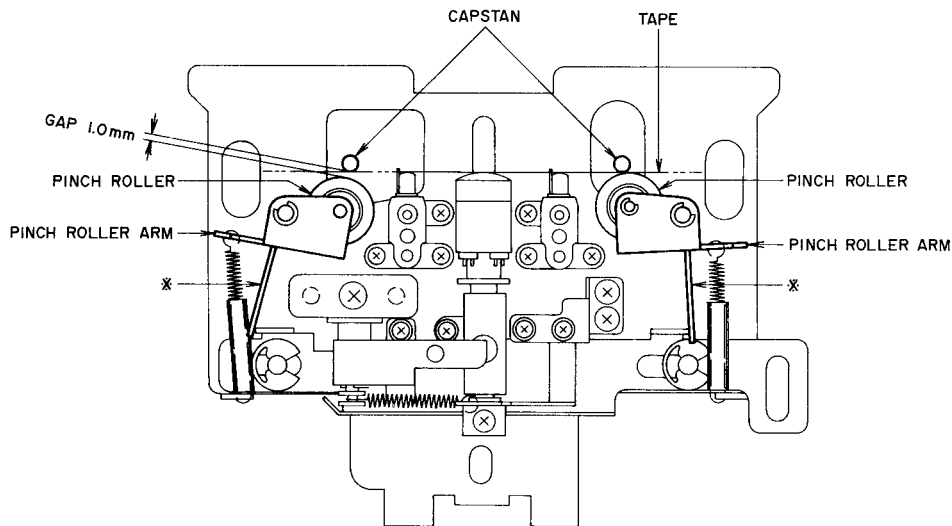

Fig. 8

3. FW WHEEL INSTALLATION POSITION ADJUSTMENT (Refer to Fig. 7)

Adjust by bending the part of wind lever resetter marked * in Fig. 7 so that at stop mode, the gap between FW Wheel and Take-up Reel is 0.5 to 1.0 mm.

4. PINCH ROLLER AND CAPSTAN GAP ADJUSTMENT (Refer to Fig. 8)

At FWD playback mode the left pinch roller separates from the capstan, and at REV playback mode, the right pinch roller separates from the capstan. Bend the part of left and right pinch roller arm marked * in the figure so that when the appropriate pinch roller separates from the capstan, the gap between the pinch roller and capstan is 1.0 mm at each respective mode.

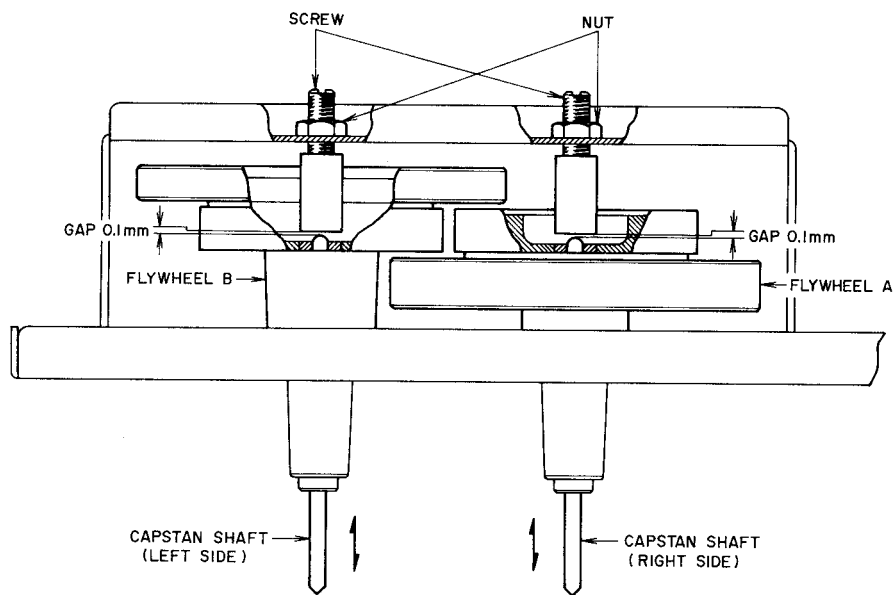

Fig. 9

5. CAPSTAN SHAFT LOOSE PLAY

ADJUSTMENT (Refer to Fig. 9)

Adjust screws and tighten nuts at point at which when the capstan shafts are moved in the directions indicated by the arrow marks in the figure, capstan loose play is 0.1 mm.

VII. HEAD ADJUSTMENT

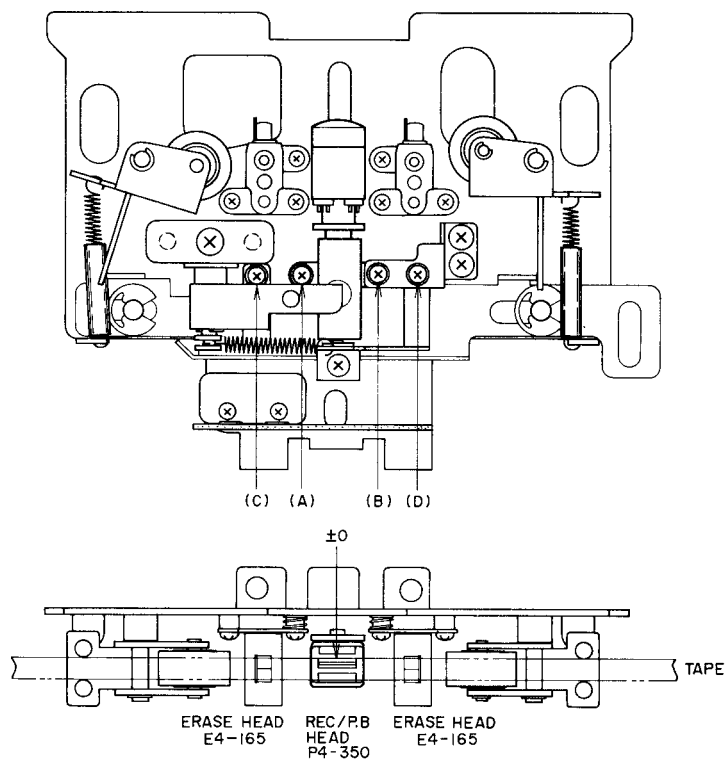

Fig. 10

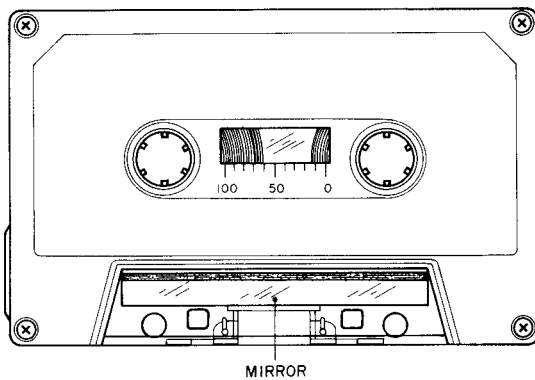

Fig. 11

Recording/Playback Head (P4-350) Alignment (Refer to Fig. 10)

Step	Adjustment Item	Test Tape Supply Signal	Mode	Adjustment Point	Remarks
1	Recording/Playback Head Height	4 track 1 kHz 0 VU recorded test tape	FWD PLAY	(A)	Maximum output, both channels. (Refer to Note 1)
2	Recording/Playback Head Azimuth	10 kHz recorded test tape	FWD PLAY	(C)	Maximum output, both channels.
3	Recording/Playback Head Height	4 track 1 kHz 0 VU recorded test tape	REV PLAY	(B)	Maximum output, both channels. (Refer to Note 1)
4	Recording/Playback Head Azimuth	10 kHz recorded test tape	REV PLAY	(D)	Maximum output, both channels.

Chart-1

- NOTES 1. When a 4 track, 1 kHz 0 VU recorded test tape is not available, for head height adjustment, use a cassette pack in which a mirror has been installed as shown in Fig. 11, and adjust head height adjustment screw until the edge of the head core and the edge of the tape are even.
2. Be sure to demagnetize the heads with a Head Demagnetizer before and after head adjustment.

RTV servis Horvat**Kešinci, 31402 Semeljci****Tel : 031-856-637****Tel / fax : 031-856-139****Mob : 098-788-319****rtv-servis-horvat@os.tel.hr**

VIII. AMPLIFIER ADJUSTMENT

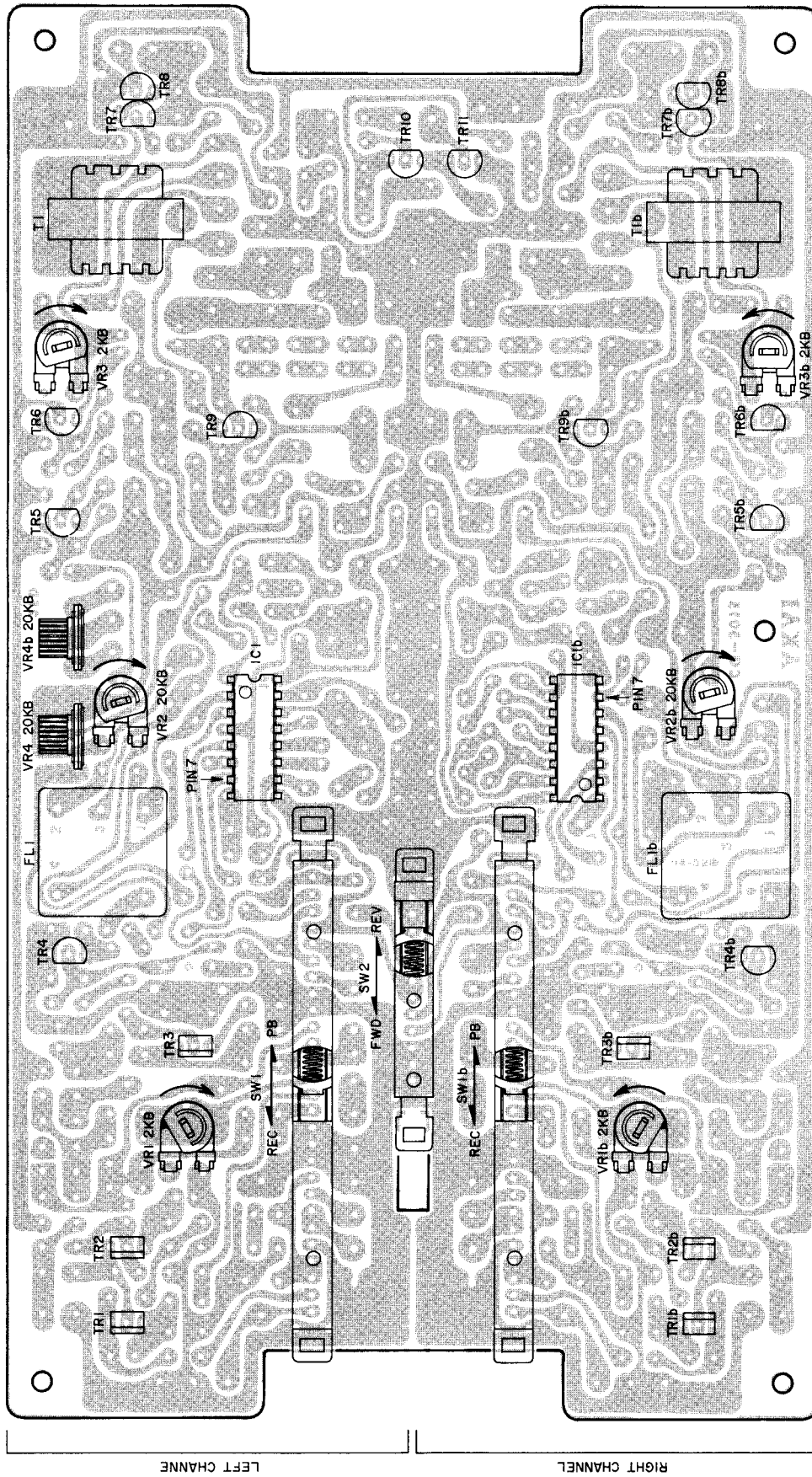

Fig. 12 Pre Amp P.C Board CQ-5015

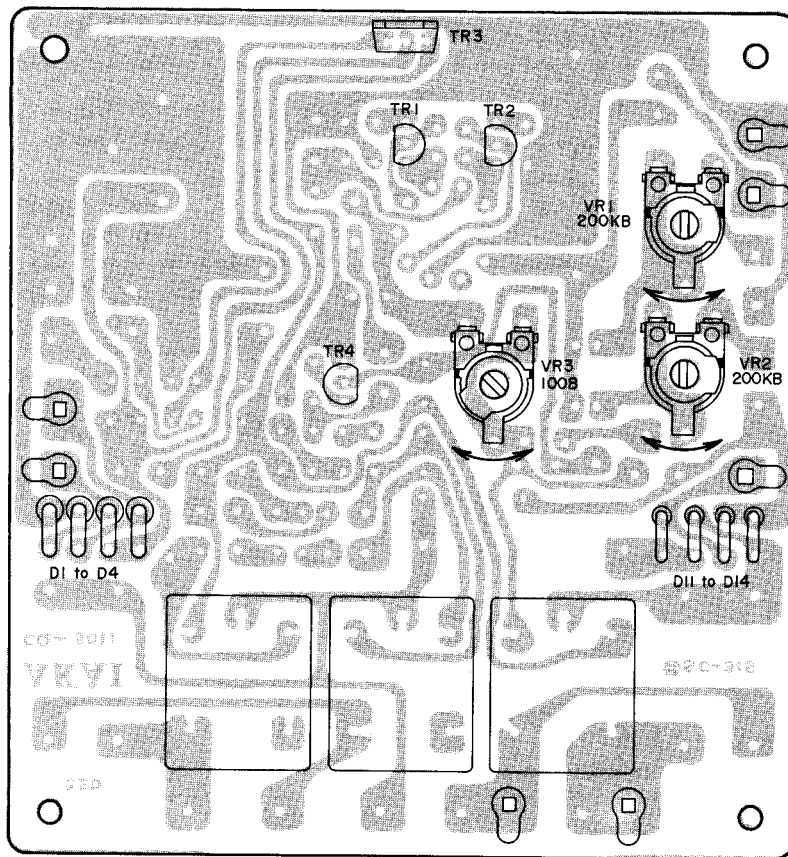

Fig. 13 OSC & Power Supply P.C Board CQ-5011

Step	Adjustment Item	Test Tape Supply Signal	Mode	Adjustment Point	Result	Remarks
1	Level of Dolby N.R. IC Pin 7	333 Hz 0 VU test tape	FWD PLAY	VR1 2 kB	-5.5 dBm (410 mV)	
2	Line Output level	333 Hz 0 VU test tape	FWD PLAY	VR2 20 kB	0 ± 0.5 dBm (0.775V)	
3	VU Meter Sensitivity	333 Hz 0 VU test tape	FWD PLAY	VR3 2 kB	0 VU	
4	Recording level (low noise tape)	Low noise blank tape, 1 kHz 0 VU recording	FWD REC	VR4 20 kB	0 ± 0.5 dBm (0.775V)	
5	Recording level (Chrome tape)	Chrome blank tape, 1 kHz 0 VU recording	FWD REC		-3 ± 1.5 dB	Confirmation only
6	Recording level (ferri-chrome tape)	Ferri-Chrome blank tape, 1 kHz 0 VU recording	FWD REC		0 ± 0.5 dBm (0.775V)	Confirmation only
7	Frequency Response (low noise tape)	Low noise blank tape, 1 kHz, 10 kHz -20 VU recording	FWD REC	VR1 200 kB (left ch) VR2 200 kB (right ch)	1 kHz, 10 kHz flat response	
8	Distortion Factor (Chrome tape)	Chrome blank tape, 1 kHz 0 VU recording	FWD REC	VR3 100B	Distortion minimum	

Chart-2

- NOTES 1. The adjustments shown above are all at FWD mode. Adjustments at REV mode are not necessary, but confirmation of each step at REV mode should be made.
2. Adjustments should be made with Limiter, Dolby N.R., and Memory Switches at OFF position.
3. Output Control should be at maximum.
4. Tape Selector should be set to LOW NOISE position except when otherwise specified.
5. Use only the tape recommended for each adjustment.

Low Noise Tape: Fuji FL C-60
 Chrome Tape: BASF CHROME DIOXIDE C-60
 Ferri-chrome Tape: Sony DUAD C-60

IX. DC RESISTANCE OF VARIOUS COILS

Part	Designation	DC Resistance
Motor	HM1-12CS	Between YLW-BLU 205 ohms Between BLU-RED 186 ohms Between RED-YLW 193 ohms
Oscillation Coil	OT-925	Between 1-3 0.3 ohms Between 4-6 1.5 ohms Between 7-9 6.1 ohms
Headphone Transformer	N19-349S	Primary 160 ohms $\pm 15\%$ Secondary 0.64 ohms $\pm 15\%$
Play Solenoid	1660PHT3	700 ohms $\pm 10\%$
Reverse Solenoid	1240PHT	600 ohms $\pm 10\%$
Auto Stop Solenoid	0730THT1	15 ohms $\pm 10\%$
Relay	LC1-C-JT DC24V	1,140 ohms $\pm 10\%$
Recording/Playback Head	P4-350	180 ohms
Erase Head	E4-165	2.5 ohms

Chart-3

X. CLASSIFICATION OF VARIOUS P.C BOARDS

1. RELATION OF P.C BOARD TITLE AND IDENTIFICATION NUMBER

P.C Board	Number of P.C Board
Pre Amp P.C Board	CQ-5015
Relay P.C Board	CQ-0015
Power Supply, OSC P.C Board	CQ-5011
Switch P.C Board A	CQ-5002
Switch P.C Board B	CQ-5003
Jack P.C Board	CQ-5034
Rev Mode P.C Board	CQ-5023
System Control P.C Board	CQ-2001
Memory Switch P.C Board	CQ-2012
Lamp P.C Board B	CQ-5022
Lamp P.C Board	CQ-1076
LED P.C Board	CQ-5021

Chart-4

2) POWER SUPPLY, OSC P.C BOARD CQ-5011

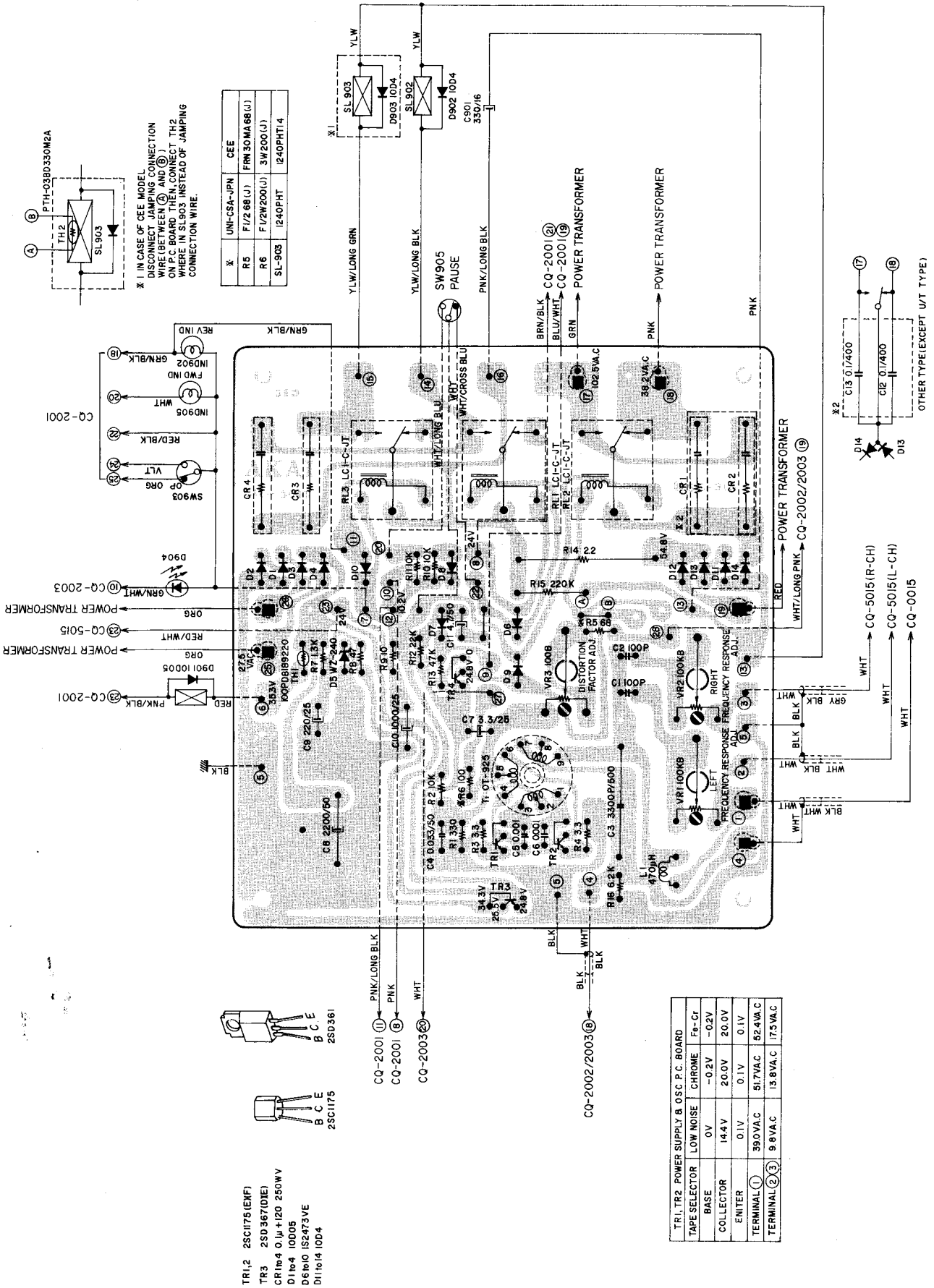

3) SWITCH P.C BOARD A CQ-5002

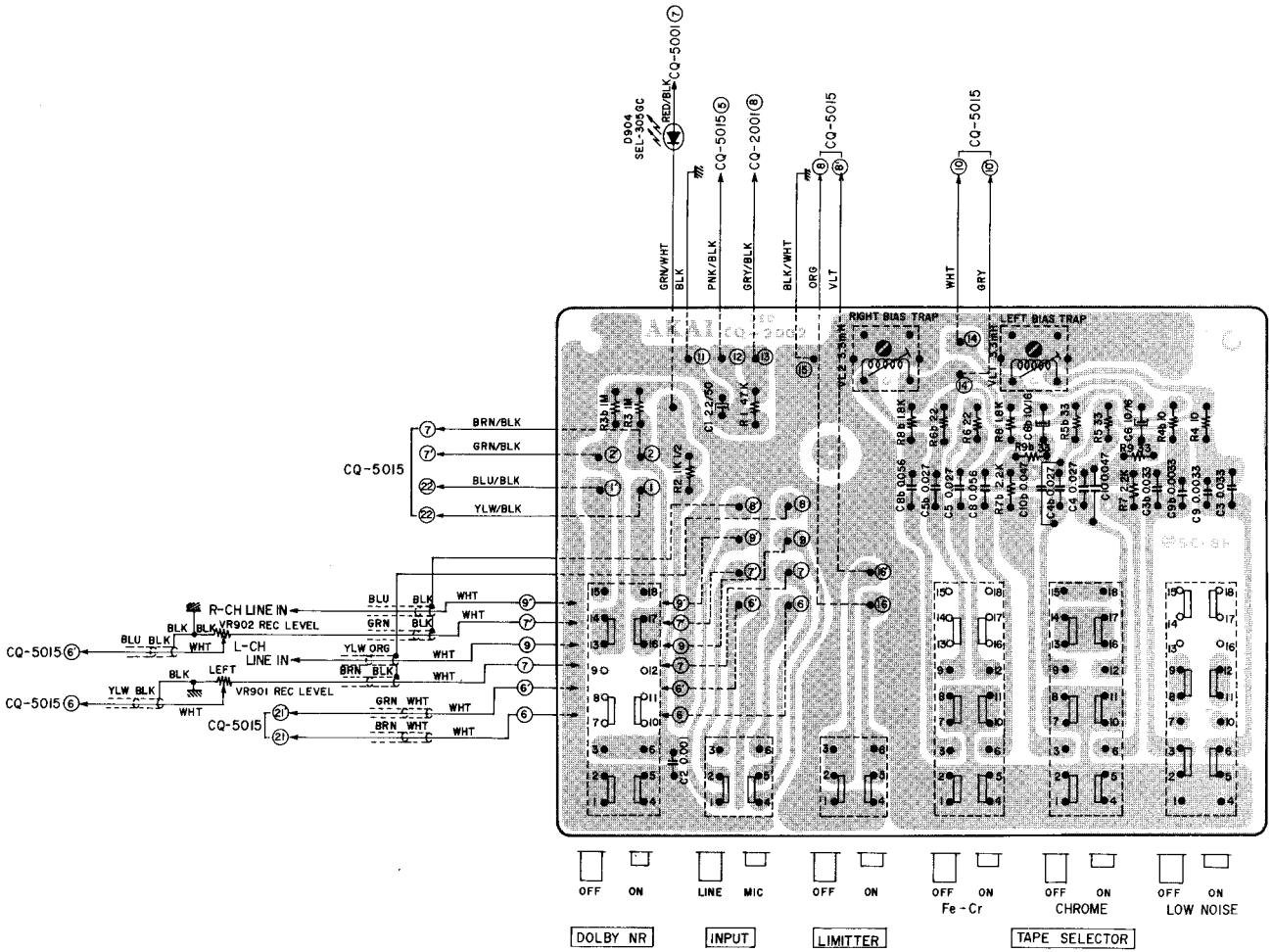

4) SWITCH P.C BOARD B CQ-5003

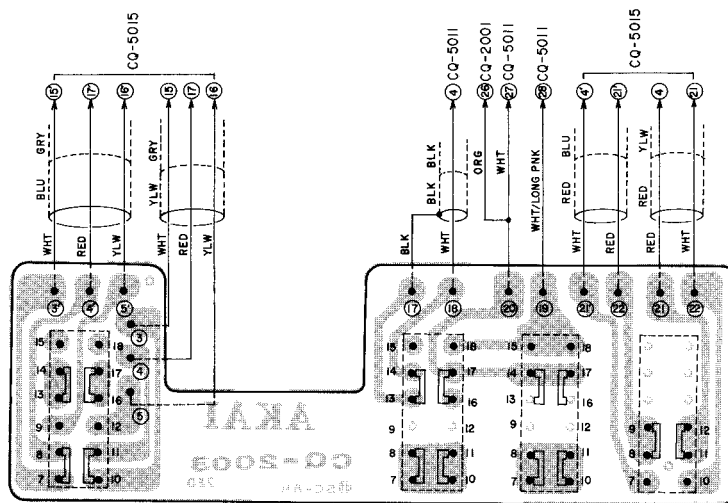

5) JACK P.C BOARD CQ-5034

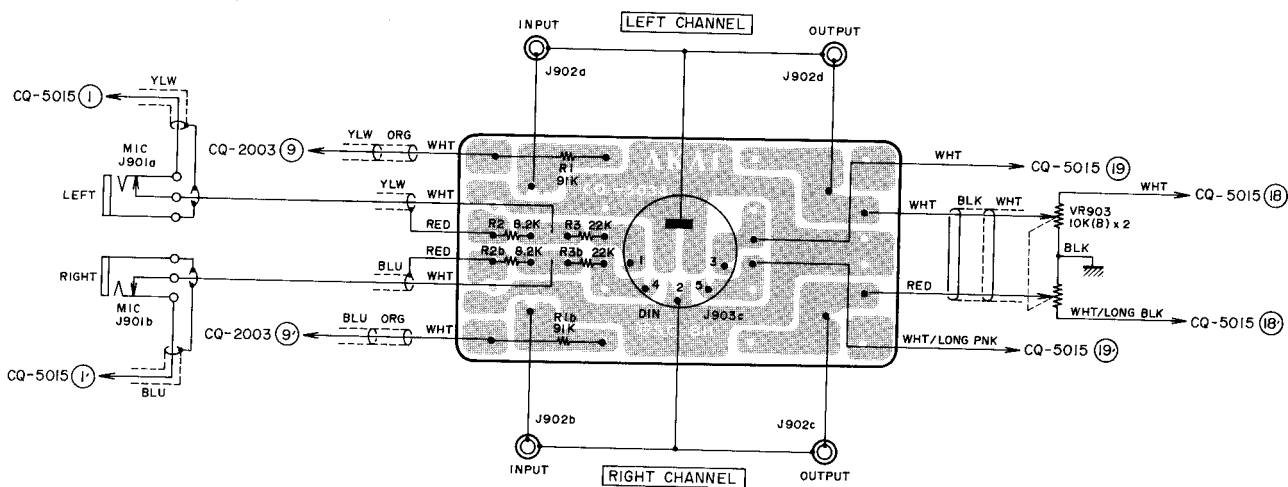

6) REV MODE P.C BOARD CQ-5023

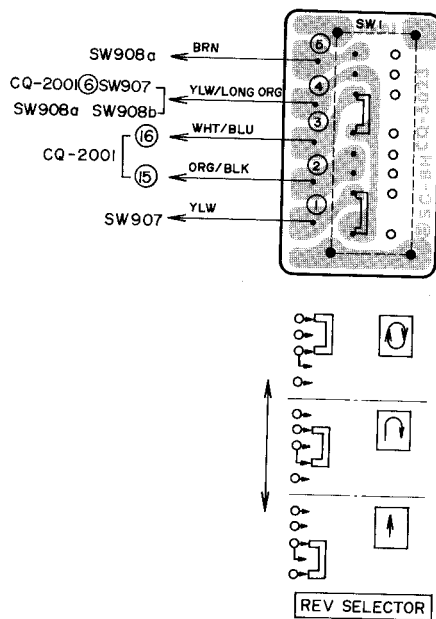

RTV servis Horvat
 Kešinci, 31402 Semeljci
 Tel : 031-856-637
 Tel / fax : 031-856-139
 Mob : 098-788-319
 rtv-servis-horvat@os.tel.hr

8) MEMORY SWITCH P.C BOARD CQ-2012

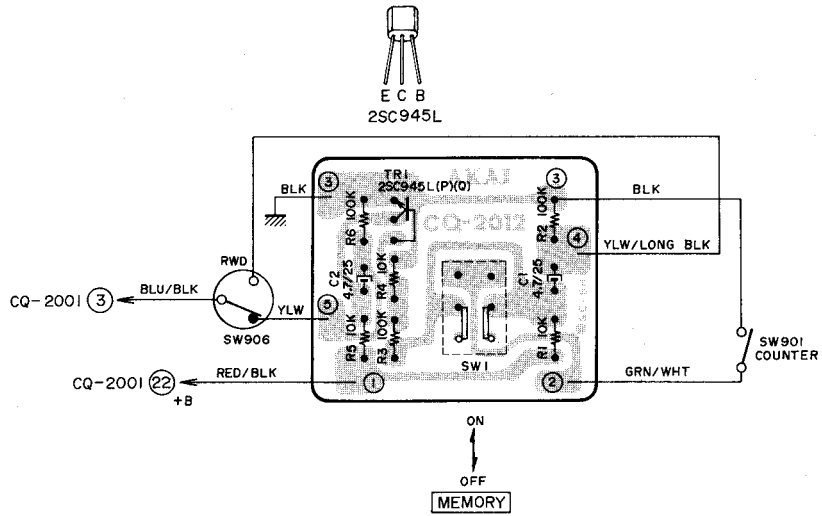

9) LAMP P.C BOARD B CQ-5022

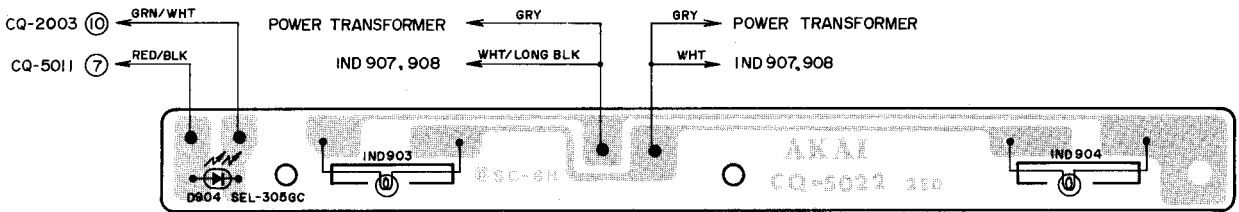

10) LAMP P.C BOARD CQ-1076

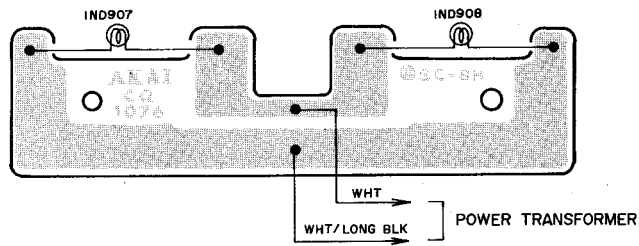

11) LED P.C BOARD CQ-5021

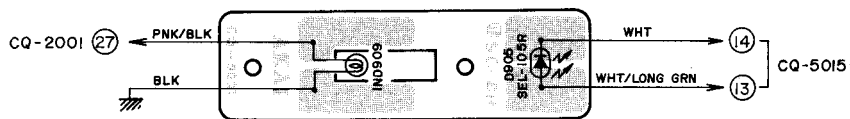

SECTION 2

PARTS LIST

TABLE OF CONTENTS

1. RECOMMENDED SPARE PARTS LIST	35
2. HEAD BASE BLOCK	37
3. REEL TABLE BLOCK	38
4. MOTOR BASE BLOCK	39
5. SUB CHASSIS BLOCK	40
6. CASSETTE HOLDER BLOCK	41
7. PLUNGER BRACKET BLOCK	42
8. PAUSE BUTTON BLOCK	43
9. MECHA FRAME BLOCK (1)	44
10. MECHA FRAME BLOCK (2)	45
11. MECHA FRAME BLOCK (3)	47
12. P.C BOARDS	48
(1) PRE AMP P.C BOARD (CQ-5015) BLOCK	48
(2) OSC, POWER SUPPLY P.C BOARD (CQ-5011) BLOCK	48
(3) REVERSE MODE P.C BOARD (CQ-5023) BLOCK	49
(4) SYS. CON P.C BOARD (CQ-2001) BLOCK	49
13. AMP ASSEMBLY BLOCK	50
14. FINAL ASSEMBLT BLOCK	52
15. LIST OF INTERCHANGEABLE SEMICONDUCTORS	53
INDEX	54

Resistor and Capacitor which is not listed in this parts list, please refer to COMMON LIST FOR SERVICE PARTS.

HOW TO USE THIS PARTS LIST

1. This parts list is compiled by various individual blocks based on assembly process.
2. When ordering parts, please describe parts number, serial number, and model number in detail.
3. How to read List

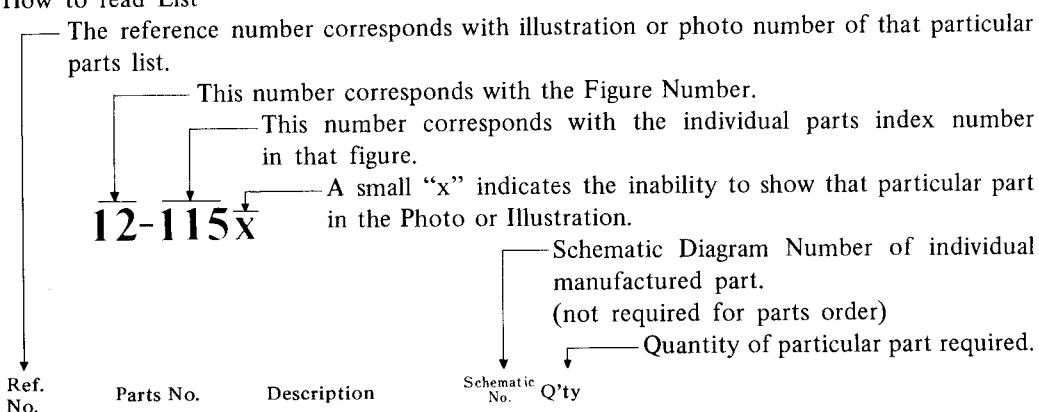

FLYWHEEL BLOCK #13

12-115x	800425	Flywheel Block Assy. Comp.	RDG #13	1
12-116	244506	Flywheel Only	RD-233	1
12-117x	244754	Felt, Flywheel	RD-275	1
12-118	251324	Main Metal Case	RD-236	1
12-119	253080	Main Metal	RD-237	1

4. The symbol numbers shown on the P.C. Board list can be matched with the Composite Views of Components of the Schematic Diagram or Service Manual.
5. Please utilize separate "Common List for Service Parts" for Resistor Parts orders.
6. The shape of the parts and parts name, etc. can be confirmed by comparing them with the parts shown on the Electrical Parts Table of P.C. Board.
7. Both the kind of part and installation position can be determined by the Parts Number. To determine where a parts number is listed, utilize Parts Index at end of Parts List.
It is necessary first of all to find the Parts Number. This can be accomplished by using the Reference Number listed at right of parts number in the Parts Index. (meaning of ref. no. outlined in Item 3 above).
8. Utilize separate "Price List for Parts" to determine unit price. The most simple method of finding parts Price is to utilize the reference number.

CAUTION:

1. When placing an order for parts, be sure to list the parts no., model no., and description. There are instances in which if any of this information is omitted, parts cannot be shipped or the wrong parts will be delivered.
2. Please be careful not to make a mistake in the parts no. If the parts no. is in error, a part different from the one ordered may be delivered.
3. Because parts number and parts unit supply in the Preliminary Service Manual (Basic Parts List) may be partially changed, please use this parts list for all future reference.

1. RECOMMENDED SPARE PARTS LIST

Because, if the parts listed below are on hand, almost any repair can be accomplished, we suggest that you stock these Recommended Spare Parts Items.

Parts No.	Description	Note
BA211746	SW P.C Board Comp. CQ-2002, CQ-2003	
BA211768	Syscon P.C Board Comp. CQ-2001	
BA211803	Memory SW P.C Board Comp. CQ-2012	
BA211972	Pre Amp P.C Board Comp. CQ-5015	
BA211994	Power Supply & OSC P.C Board Comp. CQ-5011	Switchable
BA235552	Power Supply & OSC P.C Board Comp. CQ-5011	CEE model
BA235563	Power Supply & OSC P.C Board Comp. CQ-5011	CSA model
BA235574	Power Supply & OSC P.C Board Comp. CQ-5011	JPN model
BA212040	Reverse Changing P.C Board Comp. CQ-5023	
BC219453	Wood Frame CQ-6008	
BD211634	Operation Panel Block Comp.	
BD211645	Front Panel Block Comp.	
BD681491	Lid Panel Block Comp.	Same as GXC-740D, 760D
BF217754	Flywheel A CQ-1072	
BF217765	Flywheel B CQ-1073	
BL211713	Take-up Lever Block Comp.	
BM211792	Motor (HM1-12CS) Block Comp.	
BR211691	Take-up Reel Table Block Comp.	
BR211702	Supply Reel Table Block Comp.	
BS218812	Keyboard SW Block Comp CQ-2045	
BT230984	Power Transformer CQT-1	T901 Switchable model
BT232165	Power Transformer CQT-3	T901 CEE model
BT232143	Power Transformer CQT-2	T901 CSA, JPN model
BZ210396	Clutch Block Comp.	Same as GXC-740D
BZ211904	Pause Button Block Comp.	
ED656357	Luminous Diode SEL-105R	D905
ED656346	Luminous Diode SEL-305GC	D904
EI605013	IC NE545B	
EL231265	Lamp (Cord Type) 24V 35mA	IND905, 906, 903, 904
EL295312	Lamp (L/T) 8V 0.2A	IND907, 908
EM234134	VU Meter KL-250L-10	M901, 902
EO669734	MPX Filter FB1801M	FL1
EP494425	Plunger Solenoid 0730THT1	SL901
EP638706	Plunger Solenoid 1660PHT-3	SL902
EP638695	Plunger Solenoid 1240PHT	SL903
EP616500	Relay LC1-C-JT DC24V	RL1, 2, 3
ES488970	Slide Switch SL-242B4BF	SW907
ES477966	Micro Switch SS-5GL	SW903, SW914, SW913
ES516036	Reed SW ORD-225	SW902
ES494188	Micro Switch SS-5GL-13	SW905

Parts No.	Description	Note
ES422414	Slide SW SL-242B4BD	SW908
ES665875	Push SW SDG-1P J TV-3 U/L	CSA and Switchable model
ES665807	Push SW SDG-5P 4A/32A 250V AC	CEE model
ES677305	Lever SW SLE54305	SW1
ET666404	Transistor 2SD571 (K) (L)	
EV691468	Vol VJ10R670 50 kA	VR901, 902
EV231017	Single axial 2 throw Vol. GJ70R526 10 kBx2	VR903
HE636963	Erase Head E4-165	Same as GXC-740D, 760D, 570D, 325D
HP571983	Rec/PB Head P4-350	Same as GXC-75D
MB217776	Capstan Belt CQ-1074	
MB666123	Drive Belt CA-1100	Same as GXC-710D
MB217787	Counter Belt CQ-1075	
MC213085	Counter SMP-390-98	
MP468292	Pinch Roller CG-0032	Same as GXC-710D, 75D
SK631056	Single Knob MY-6208	Rec Level Knob
SK219497	Single Knob CQ-6009	Output Knob
SK634410	Push Button Knob J 91-5051	

2. ILLUSTRATION OF HEAD BASE BLOCK

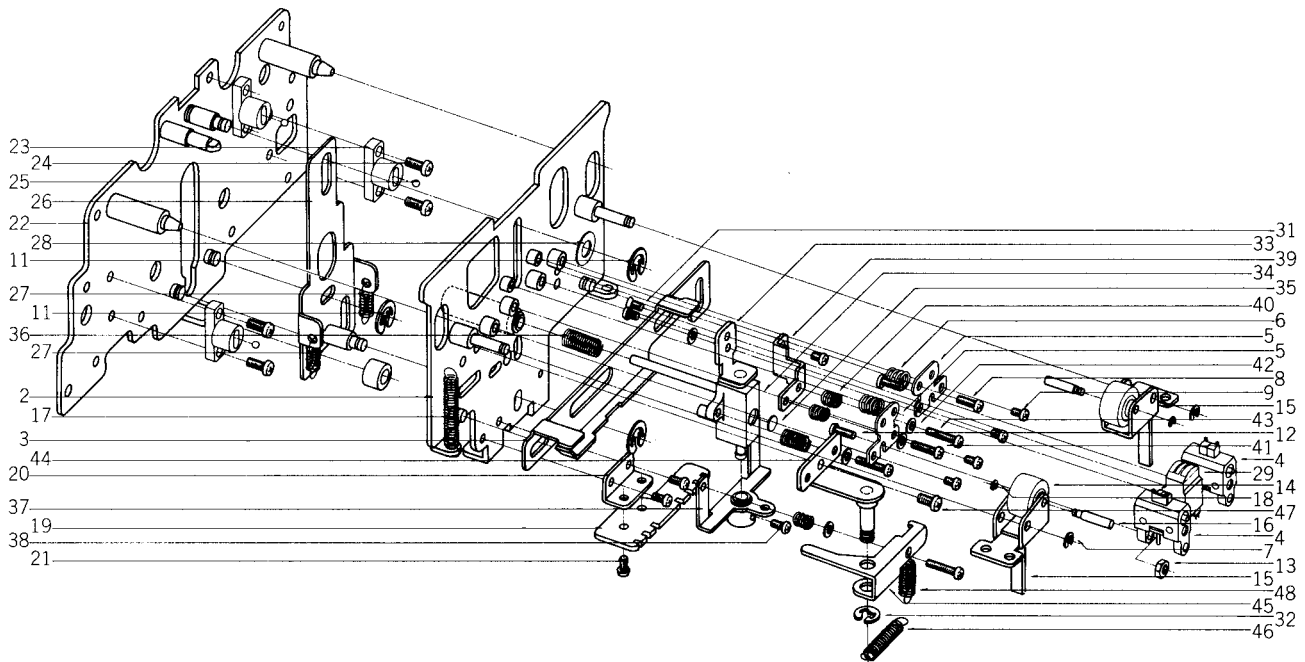

2) HEAD BASE BLOCK

Ref. No.	Parts No.	Description	Schematic No.	Q'ty	Ref. No.	Parts No.	Description	Schematic No.	Q'ty
HEAD BASE BLOCK					HEAD BLOCK				
2-1x	BH286637	Head Base Block Comp.	CQ-9806A-F	1	2-27	ZG216483	Head Base Spring	CQ-0013	2
2-2	HZ268784	Head Base Part CQ	CQ-0001	1	2-28	ZW374545	Washer (PBP) D5.1×10.3×0.4t		1
2-3	TC216382	Changing Slide	CQ-0008	1					
2-4	HE636963	ERASE HEAD E4-165 CW		2	2-29	HP571983	REC/PB HEAD P4-350		1
2-5	HZ567202	Erase Head Plate	CP-0029	2	2-30x	ZS300626	Screw, pan head 2×2.5 (Camera Standard)		2
2-6	ZG227114	EH Adjust Spring	CA-0214	2	2-31	ZS399148	Screw, countersunk head 2×3		1
2-7	ZW270088	'E' Ring 1.9M	6-1-9	4	2-32	ZW270101	'E' Ring 3M	6-1-9	3
2-8	ZS356861	Screw, pan head 2×6		2	2-33	HZ294524	Head Mt. Base (A) Part CQ	CP-0025	1
2-9	ZS477876	Screw, pan head 2×3		4	2-34	EZ696431	Head Holder Part CP	CP-0019	1
2-10x	ZS417161	Screw, pan head 2.3×4		2	2-35	ZW567630	Up & Down Washer	CP-0017	1
2-11	ZW290283	'U' Ring 2.85M	6-1-1	7	2-36	ZG300828	Hold-down Spring (2)	CQ-0023	1
2-12	ZS201936	Screw, binding head 2.3×6		2	2-37	ML683594	Azimuth Lever Part CP	CP-0023	1
2-13	ZW699052	Nut, M2.3 D2.3×5×2.3t		2	2-38	ZS375107	Screw, pan head 2.6×4		1
2-14	MP468292	Pinch Roller, CG D=13	CG-0032	2	2-39	HZ567213	Adjust Base	CP-0031	1
2-15	ML216393	Pinch Roller Arm CQ	CQ-0009	2	2-40	ZG402895	CS Angle Adjust Spring	CS-0024	2
2-16	MS389981	Pinch Roller Shaft	CS-0011	2	2-41	ZS484918	Screw, pan head 2×8		2
2-17	ZG216494	P Spring	CQ-0014	2	2-42	ZW318014	Washer (BSP) D2.6×4.5×0.4t		2
2-18	ZW391397	'E' Ring 1.2M	6-1-9	2	2-43	ZS572804	Screw, pan head 2×10		2
2-19	EA219600	Relay P.C Board	CQ-0015	1	2-44	HZ268896	Head Up and Down Bracket (2) Part CQ	CQ-0005	1
2-20	TC293174	Relay Mt. Base	CQ-0022	1	2-45	ML216371	Head Adjust Lever 2	CQ-0007	1
2-21	ZS417161	Screw, pan head 2.3×4		2	2-46	ZG230051	Stop Spring	CQ-2046	1
2-22	TC268885	Sub Frame Part CQ	CQ-0003	1	2-47	ZS422076	Screw, pan head 3×5		1
2-23	MS645153	Ball Guide	CA-2013	3	2-48	ZG230692	Head Spring	CQ-0016	1
2-24	ZS379350	Screw, pan head 3×6		6					
2-25	MV250920	Steel Ball D2.38		3					
2-26	TC268874	Playslide Part CQ	CQ-0011	1					

When ordering parts, Please describe Parts Number, Description, and Model Number in detail.

3. ILLUSTRATION OF REEL TABLE BLOCK

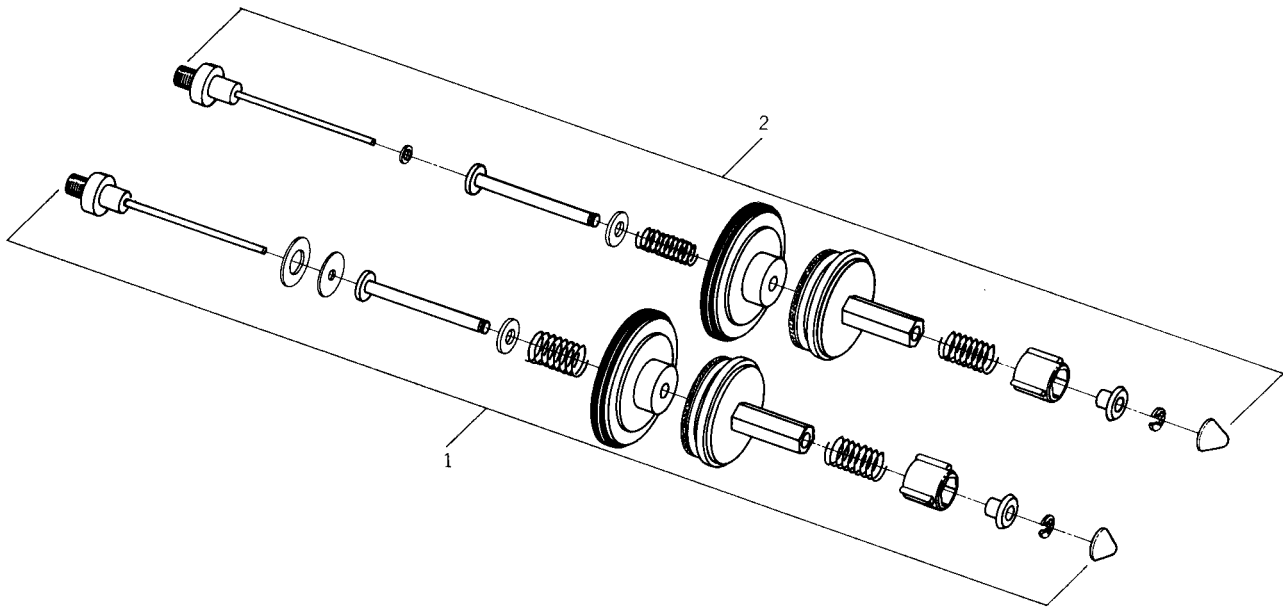

3) REEL TABLE BLOCK

Ref. No.	Parts No.	Description	Schematic No.	Q'ty
3-1	BR211702	Supply Reel Table Block		
		Comp.	CW 9802	1
3-2	BR211691	Take-up Reel Table Block		
		Comp.	CG 9801	1

4. ILLUSTRATION OF MOTOR BASE BLOCK

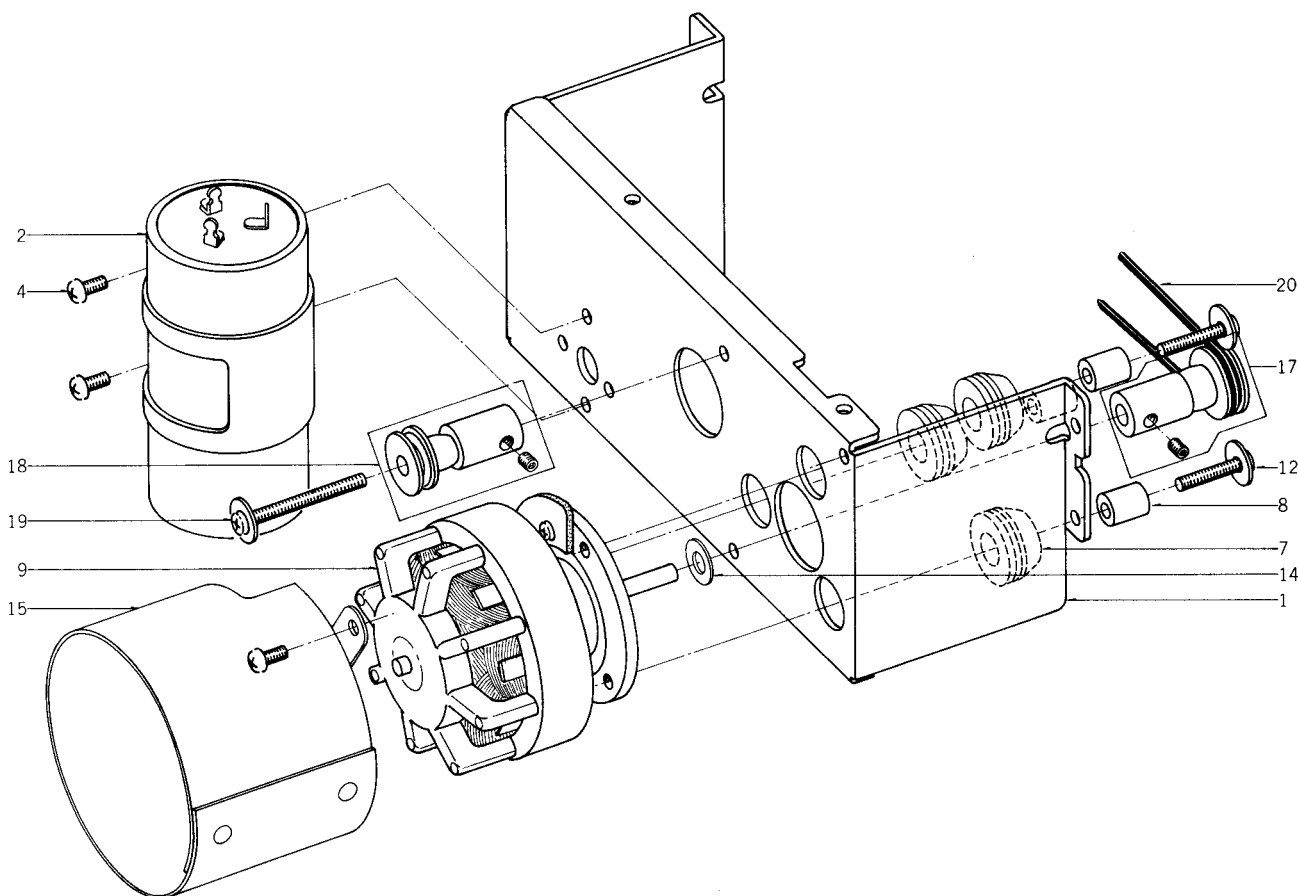

4) MOTOR BASE BLOCK

Ref. No.	Parts No.	Description	Schematic No.	Q'ty
4-1	MZ219510	Motor Mt. Base	CQ 7001	1
4-2	EC641338	MP/C. (Lug Type UNI/D.) 7+1 μ F 150WV AC	24-9-95	1
4-3x	EC641340	MP/C. (Lug Type UNI/D.) 7 μ F 150WV AC (CSA)	24-9-101	1
4-4	ZS325495	Tapping Screw #2, 3x6 (BR)		4
4-5x	ZW562476	Earth Lug M3		2
4-6x	ZS455207	Tapping Screw #2, 3x5 (BR)		1
4-7	TC384164	Rubber Cushion Bush	24X0-717	3
4-8	MZ646290	Spacer 3x8.5	7-2-6	3
4-9	BM571904	Motor (HM1-12CS) Block Comp. GXC-75D		1
4-10x	EZ638965	Cord Support	2-7-50	1
4-11x	ZS379350	Screw, pan head 3x6 (CEE, CSA)		1
4-12	ZS290496	Screw, pan head 3x15 (W=10)		2
4-13x	ZS422965	Screw, pan head 3x15		1
4-14	ZW479294	Washer (SUP) D4.2x10x0.8t		1
4-15	TC642385	Motor Shield GXC-710D	CA-7005	1
4-16x	TC394075	Oil Cut	CS-7028	1
4-17	MR281845	Motor Pulley (A) Part GXC-730D	CQ 7002	1
4-18	MR281834	Motor Pulley (B) Part GXC-730D	CQ-7003	1
4-19	ZS608354	Screw, pan head 3x30		1
4-20	MB666123	Drive Belt	CA 1100	1

RTV servis Horvat

Kešinci, 31402 Semeljci

Tel : 031-856-637

Tel / fax : 031-856-139

Mob : 098-788-319

rtv-servis-horvat@os.tel.hr

5. ILLUSTRATION OF SUB CHASSIS BLOCK

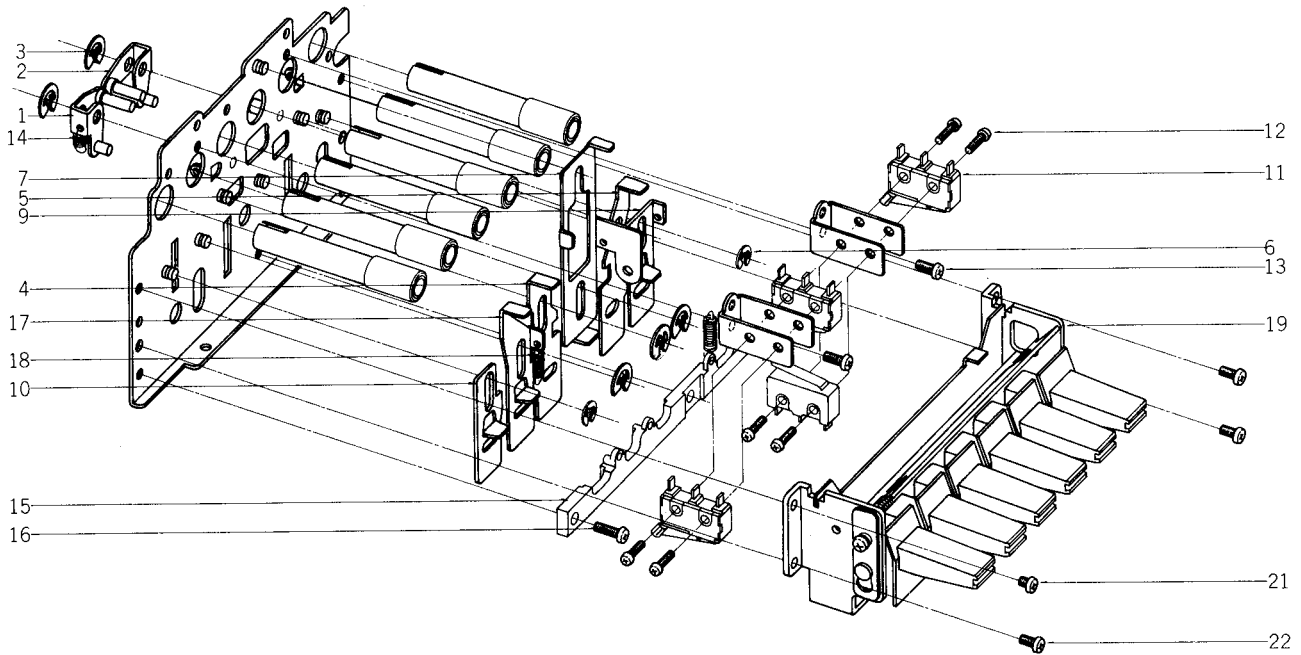

5) SUB CHASSIS BLOCK

Ref. No.	Parts No.	Description	Schematic No.	Q'ty
5-1	ML268918	Lock Lever (A) Part CQ	CQ-2041	1
5-2	ML268920	Lock Lever (B) Part CQ	CQ-2041	1
5-3	ZW290283	'U' Ring 2.85M	6-1-1	4
5-4	MZ218586	Play Slider A	CQ-2037	1
5-5	MZ218621	Play Slider B	CQ-2037	1
5-6	ZW270101	'E' Ring 3M	6-1-9	4
5-7	TC268841	Stop Slider Part CQ	CQ-2036	1
5-8	ZG387178	Idler Tension Spring	CS-1106	1
5-9	TC642161	Inter Lock Slide	CA-2033	1
5-10	MZ218711	Inter Lock Slide	CQ-2042	1
5-11	ES494188	Micro SW. SS-5GL-13	25-1-25	4
5-12	ZS391522	Screw, pan head 2.3x8		8
5-13	ZS325495	Tapping Screw #2 3x6 (BR)		2
5-14	ZG456120	Setting Lever Spring	CS-1187	2
5-15	MS645175	Slider Guide	CA-2035	1
5-16	ZS666336	Tapping Screw #2, 3x8 (PAN)		3
5-17	MZ218643	RWD Slide 1	CQ-2038	1
5-18	ZG422223	Return Spring	PX-A132	1
5-19	BK218812	Keyboard SW. Comp. CQ	CQ-2045	1
5-20x	ZS419670	Screw, pan head 3x12		1
5-21	ZS417216	Screw, pan head 3x4		2
5-22	ZS379350	Screw, pan head 3x6		2

When ordering parts, Please describe Parts Number, Description, and Model Number in detail.

6. ILLUSTRATION OF CASSETTE HOLDER BLOCK

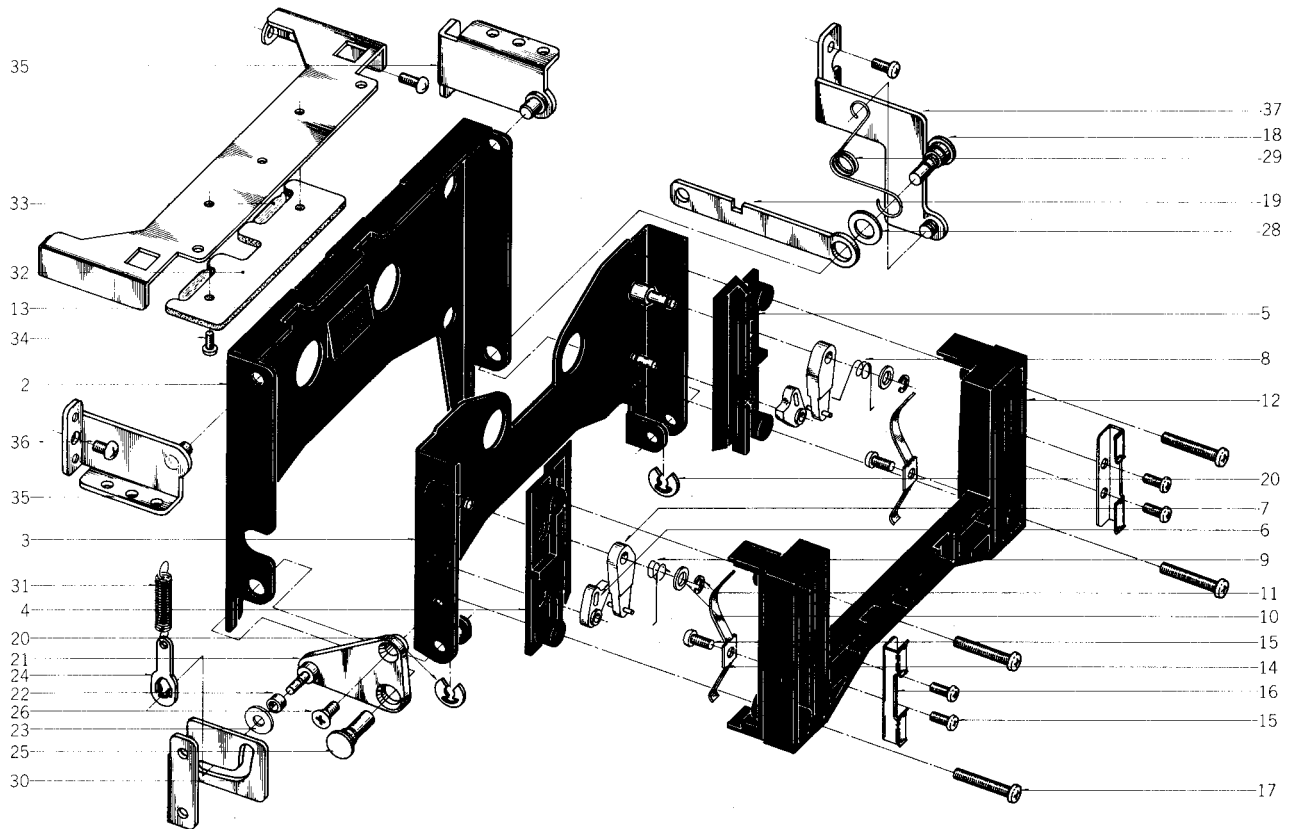

6) CASSETTE HOLDER BLOCK

Ref. No.	Parts No.	Description	Schematic No.	Q'ty	Ref. No.	Parts No.	Description	Schematic No.	Q'ty
CASSETTE HOLDER BLOCK									
6-1x	BZ211860	Cassette Holder Block Comp.	CB-2046	1	6-21	ML204862	Eject Guide Arm A Part CB	CA-2027	1
6-2	TC685260	Trap Part CA	CA-2020	1	6-22	MR203804	Roller	CB-1056	1
6-3	TC646920	Cassette Rack CA	CA-2023	1	6-23	ZW259503	Washer (Nylon) D3.1x8x0.5t		1
6-4	MS595563	Cassette Guide L	CH-2007	1	6-24	TC203815	Spring Hook	CB-1057	1
6-5	MS595552	Cassette Guide R	CH-2006	1	6-25	MH644916	Hinge Pin	CA-2028	1
6-6	ML595574	Detector Lever A	CH-2008	2	6-26	ZS414033	Screw, countersunk head 3x8		1
6-7	ML595585	Cassette Lever B	CH-2009	2	6-27x	ZG227452	Spring D	900-118	1
6-8	ZG595618	Spring A	CH-2004	1	6-28x	ZW322110	Washer (Nylon) D6.1x10.3x1.0t		1
6-9	ZG595620	Spring B	CH-2005	1	6-29	ZG218790	Click Spring B	CQ-2044	1
6-10	ZW592391	Washer (PBP) D3.2x6x0.3t		2	6-30	MS218114	Eject Guide	CQ-2024	1
6-11	ZW270088	'E' Ring 1.9M	6-1-9	2	6-31	ZG365321	Idler Lever Spring	RCC-1385	1
6-12	TC647065	Cassette Case	CA-2024	1	LAMP STAND BLOCK				
6-13	TC645186	Reflector	CA-2071	1	6-32	EA234246	Lamp P.C Board	CQ-1076	1
6-14	ZG207257	Sheet Spring	CI-2019	1	6-33	EL295312	Lamp (L/T) 8V 0.2A	28-2-8	2
6-15	ZS669104	Tapping Screw #2, 2.3x6 (PAN)		6	6-34	ZS417161	Screw, pan head 2.3x4		2
6-16	TC642148	Lid Chuck	CA-2026	2	6-35	TC684360	Pin Stand Part CA	CA-1099	2
6-17	ZS592402	Screw, pan head 3x18		4	6-36	ZS325495	Tapping Screw #2, 3x6 (BR)		2
6-18	MH664064	Hinge Pin B	CB-2029	1	6-37	TC280664	Spring Base Part CQ	CQ-1067	1
6-19	TC666156	Band Plate B	CB-2024	1					
6-20	ZW290283	'U' Ring 2.85M	6-1-1	2					

7. ILLUSTRATION OF PLUNGER BRACKET BLOCK

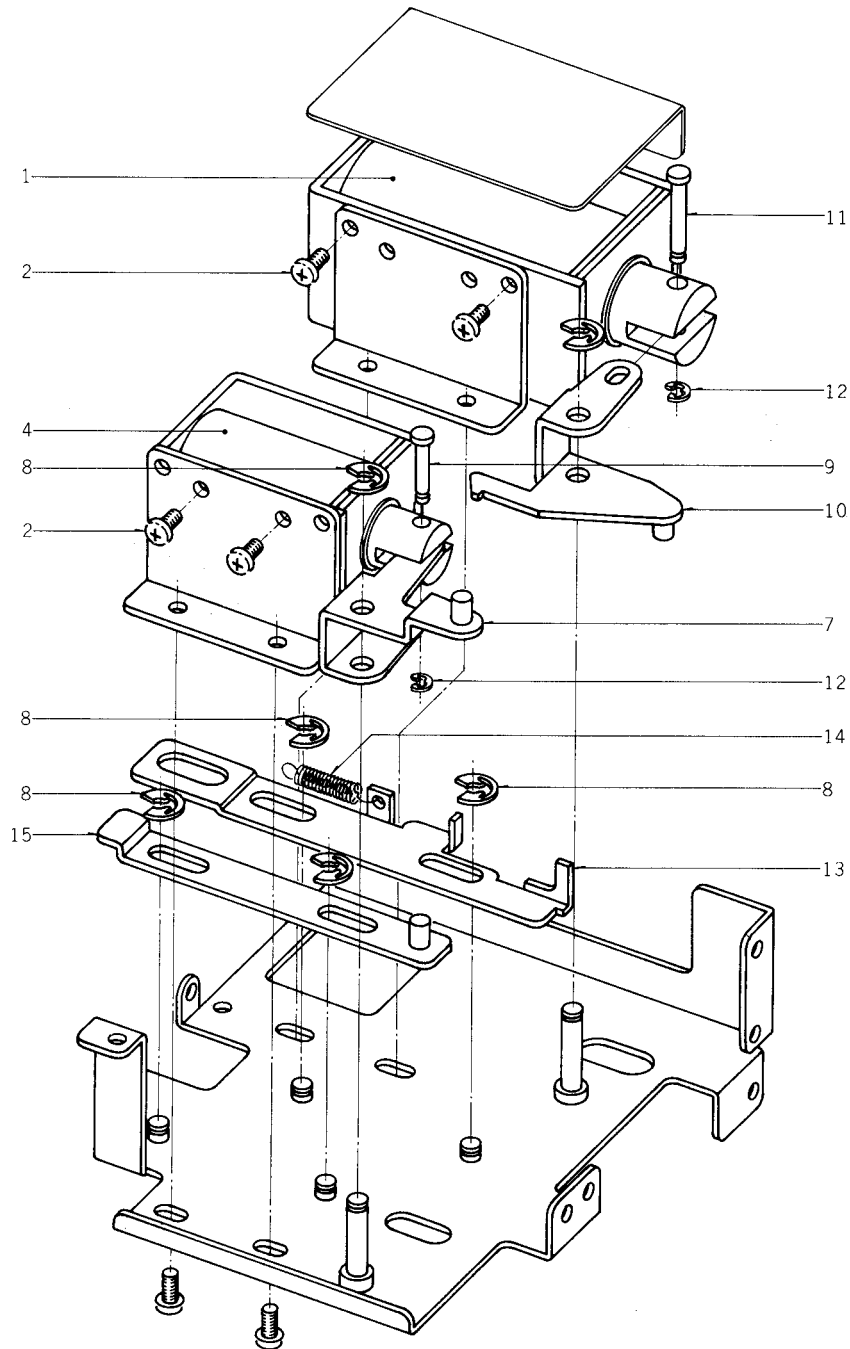

7) PLUNGER BRACKET BLOCK

Ref. No.	Parts No.	Description	Schematic No.	Q'ty	Ref. No.	Parts No.	Description	Schematic No.	Q'ty
7-1	EP638706	Plunger Solenoid 1660PHT	44-1-74	1	7-8	ZW290283	'U' Ring 2.85M	6-1-1	6
7-2	ZS323728	Screw, binding head 3x5		4	7-9	MH257477	Connecting Pin	RD-211	1
7-3	ZS422076	Screw, pan head 3x5		4	7-10	ML268727	Drive Lever Part CQ	CQ-2016	1
7-4	EP638695	Plunger Solenoid 1240PHT	44-1-73	1	7-11	MH533913	Connecting Pin	TW-2010	1
7-5x	EP263136	Plunger Solenoid 1240PHT14 (CEE)	44-1-86	1	7-12	ZW270088	'E' Ring 1.9M	6-1-9	2
7-6x	ED224550	Silicon Diode 10D4	45-2-16	2	7-13	MZ218057	REC Joint Slide	CQ-2019	1
7-7	ML268762	Plunger Lever (1) Part CQ	CQ-2015	1	7-14	ZG365321	Idler Lever Spring	RCC-1385	1
					7-15	ML268773	Reverse Joint Lever Part CQ	CO-2018	1

When ordering parts, Please describe Parts Number, Description, and Model Number in detail.

8. ILLUSTRATION OF PAUSE BUTTON BLOCK

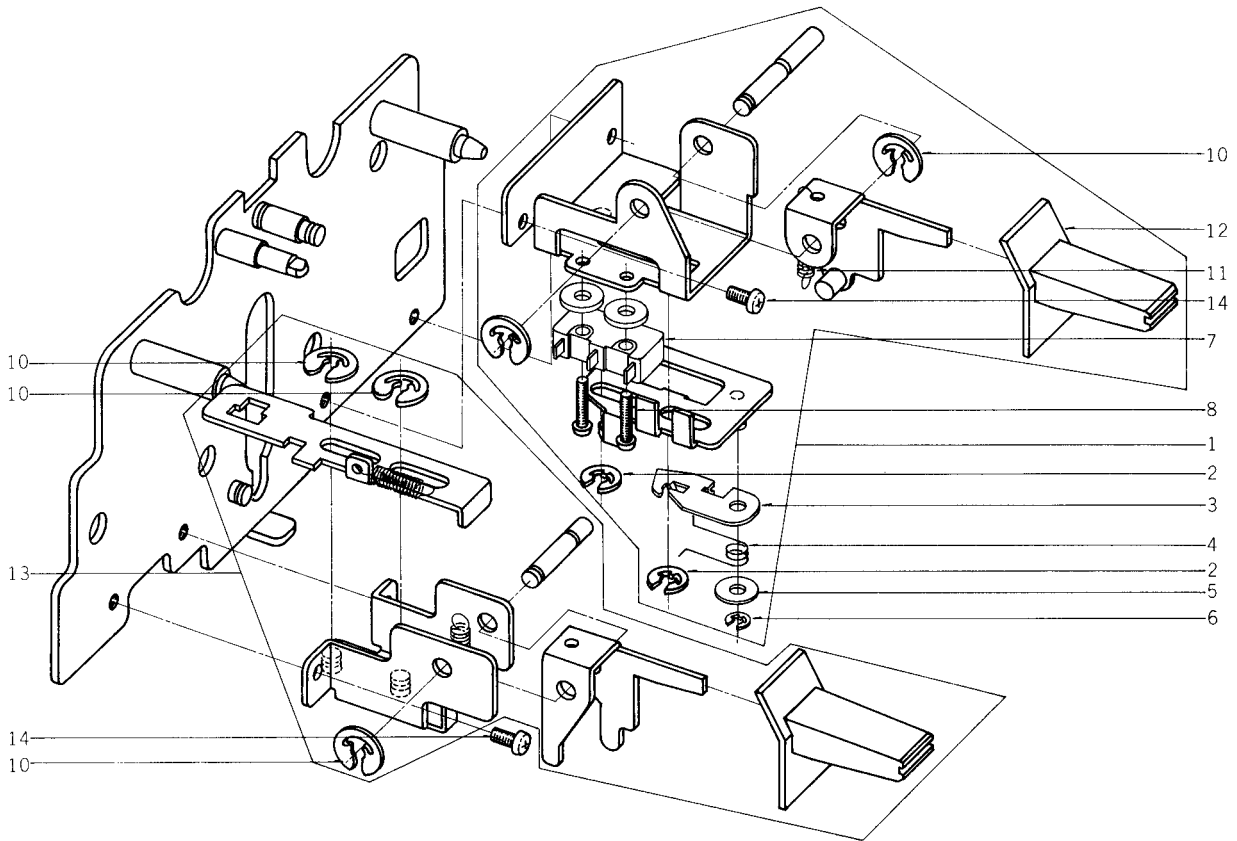

8) PAUSE BUTTON BLOCK

Ref. No.	Parts No.	Description	Schematic No.	Q'ty
8-1	BZ211904	Pause Button Block Comp.	CQ-9713	1
8-2	ZW270101	'E' Ring 3M	6-1-9	2
8-3	TC515575	SW. Lock Cam B	CG-2301	1
8-4	ZG514440	Button Lock Spring B	CG-2303	1
8-5	ZW302332	Washer (BSP) D3.1x8x0.5t		1
8-6	ZW270088	'E' Ring 1.9M	6-1-9	1
8-7	ES494188	Micro SW. SS-5GL-13	25-1-25	1
8-8	ZS364397	Screw, pan head 2.3x10		2
8-9x	ZS462947	Screw, pan head 2.3x12		1
8-10	ZW290283	'U' Ring 2.85M	6-1-1	2
8-11	ZG577945	FF Slide Lever Spring	PW-1022	1
8-12	ML645377	Function Lever C	CA-2046	1
8-13	BZ211893	Eject Button Block Comp.	CQ-9703	1
8-14	ZS422076	Screw, pan head 3x5		2

9. ILLUSTRATION OF MECHA FRAME BLOCK (1)

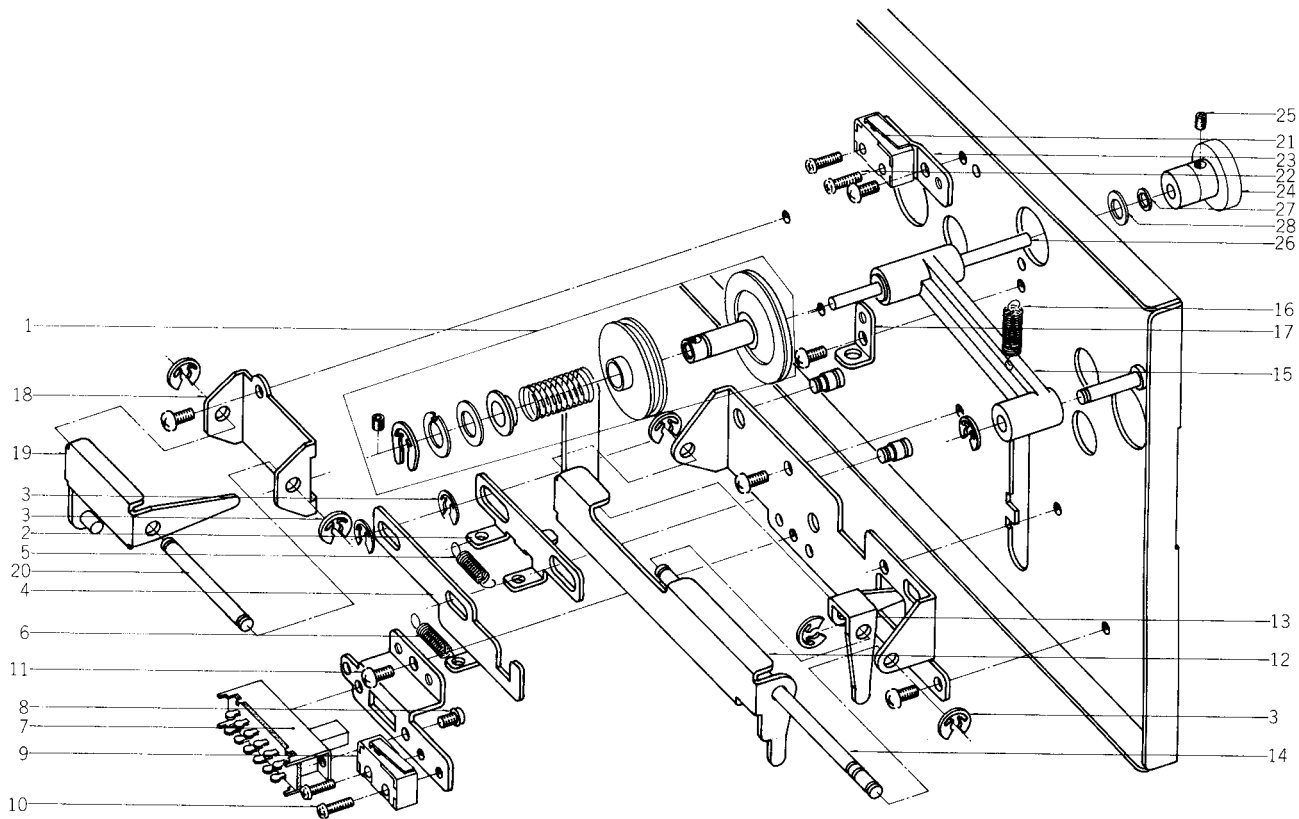

9) MECHA FRAME BLOCK (1)

Ref. No.	Parts No.	Description	Schematic No.	Q'ty
9-1	BZ681568	Clutch Block Comp.	CA-1114	1
9-2	MZ217530	SW. Slide 1	CQ-1060	1
9-3	ZW290283	'U' Ring 2.85M	6-1-1	10
9-4	MZ217541	SW. Slide 2	CQ-1061	1
9-5	ZG230782	SW. Base Return Spring	CQ-1081	1
9-6	ZG262271	FF Return Spring	CQ-1089	1
9-7	ES488970	Slide SW. SL-242B4BF	25-3-76	1
9-8	ZS432843	Screw, pan head 2.6x4		2
9-9	ES477966	Micro SW. SS-5GL	25-1-23	1
9-10	ZS487091	Screw, pan head 2.3x8		2
9-11	ZS325495	Tapping Screw #2, 3x6 (BR)		2
9-12	ML269010	Eject Lever (2) Part CQ	CQ-1025	1
9-13	ML216810	Eject Lever 3	CQ-1026	1
9-14	MS216821	Eject Shaft	CQ-1027	1
9-15	ML268931	Wheel Arm Part CQ	CQ-1078	1
9-16	ZG262585	Spring, wheel arm	CQ-1087	1
9-17	MZ217528	Spring Hanger	CQ-1059	1
9-18	MZ216707	Rec Bracket	CQ-1020	1
9-19	ML280653	REC Lever Part CQ	CQ-1021	1
9-20	MS216731	REC Shaft	CQ-1022	1
9-21	ES477966	Micro SW. SS-5GL	25-1-23	1
9-22	ZS487091	Screw, pan head 2.3x8		2
9-23	TC641880	REC SW. Table	CA-1074	1
9-24	MI678633	Driving Wheel (B)	CA-1209/1210	1
9-25	ZS434160	Set Screw, hexagon socket 3x3 (Cup/p.)		1
9-26	MS644613	Drive Wheel Shaft	CA-1028	1
9-27	ZW484762	Washer (Teflon) D3.1x5x0.2t		6
9-28	MZ678508	Oil Cut	CA-1110	1

When ordering parts, Please describe Parts Number, Description, and Model Number in detail.

10. ILLUSTRATION OF MECHA FRAME BLOCK (2)

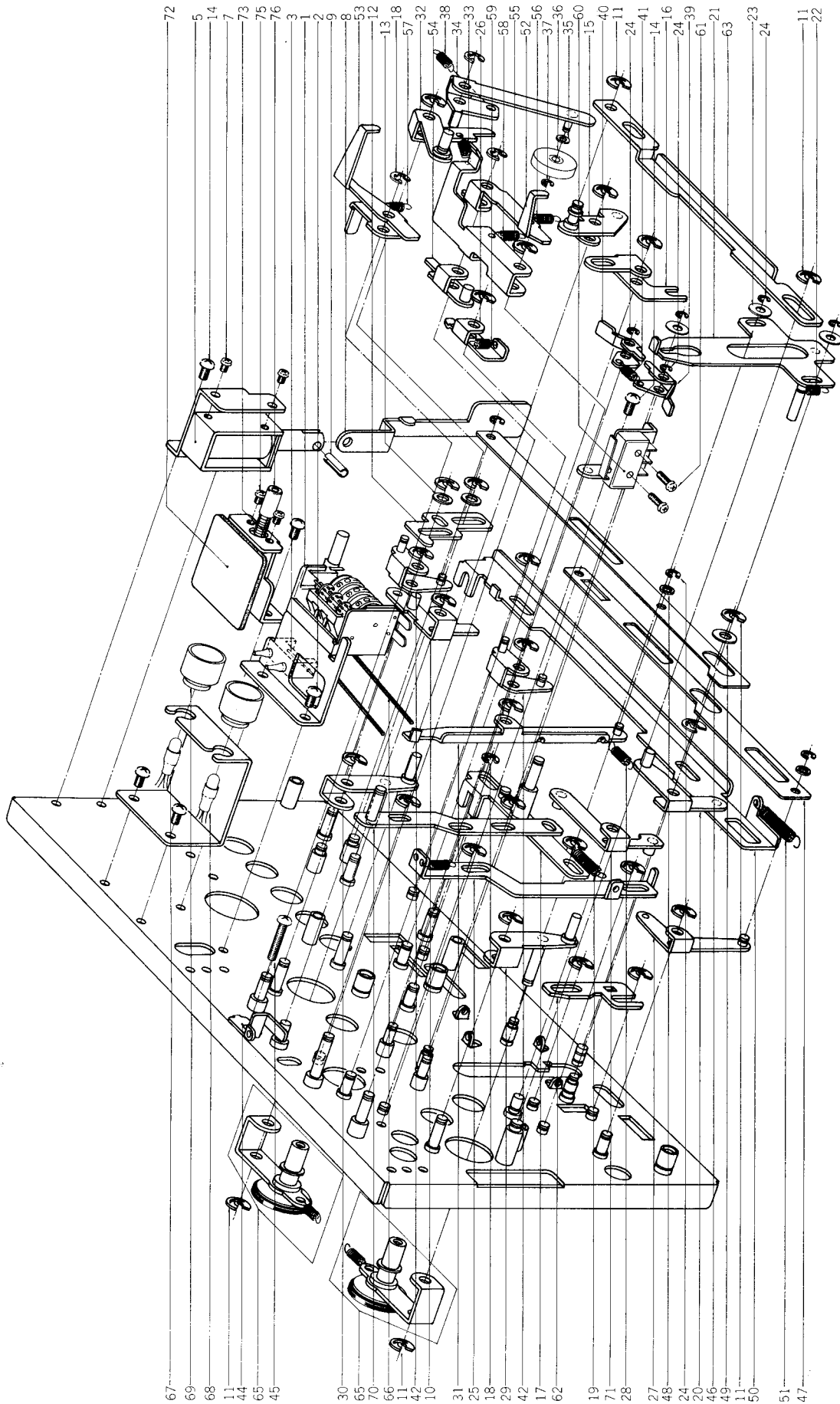

10) MECHA FRAME BLOCK (2)

Ref. No.	Parts No.	Description	Schematic No.	Q'ty	Ref. No.	Parts No.	Description	Schematic No.	Q'ty	
COUNTER BLOCK										
10-1	MC213085	Counter SMP-390-73	9-1-48	1	10-66	MB217787	Counter Belt	CQ-1075	1	
10-2	ZS422076	Screw, pan head 3x5		2	10-67	EL231265	Lamp (Cord Type) 24V 35 mA (200/150mm)	28-2-42	1	
10-3	ES516036	Lead SW. ORD-225	25-11-1	1	10-68	EL231254	Lamp (Cord Type) 24V 35mA (220mmx2)	28-2-42	1	
PLUNGER BASE BLOCK										
10-4	MZ217574	Plunger Base	CQ-1063	1	10-69	MZ217675	Lamp Holder C	CQ-1066	2	
10-5	EP494425	Plunger Solenoid 0730THTI	44-1-48	1	10-70	TC280620	Eject Connection Plate Part	CQ	CQ-1030	1
10-6x	ED494583	Silicon Diode 10D05	45-2-42	1	10-71	ML280631	Eject Arm Part CQ	CQ-1029	1	
10-7	ZS592378	Screw, pan head 2.6x3		2	MEMORY SW. P.C BOARD BLOCK					
10-8	ML217552	Auto Stop Lever	CQ-1062	1	10-72	BA211803	Memory SW. P.C Board			
10-9	MH620572	Spring Pin		1			Comp.	CQ-9754	1	
MECHA FRAME BLOCK										
10-10	ML268997	Cancellation Lever Part CQ	CQ-1042	1	10-73	ES558944	Push SW. SPJ-10110	25-5-109	1	
10-11	ZW290283	'U' Ring 2.85M	6-1-1	29	10-74x	ET635231	Transistor 2SC536 (F) (G)	45-1-55	1	
10-12	ML217091	Play Stop Lever	CQ-1043	1	10-75	ZS460440	Screw, pan head 2x4		2	
10-13	ZW649991	Washer (PBP) D4.1x7x0.3t		2	10-76	SZ645221	Memory Cap CA	CA-6010	1	
10-14	ZS325495	Tapping Screw #2, 3x6(BR)		9						
10-15	ML269021	Interlocking Lever (2) Part CQ	CQ-1039	1						
10-16	MZ216990	Interlock Plate 1	CQ-1038	1						
10-17	TC268986	Direction Slide Part CQ	CQ-1037	1						
10-18	ZW270101	'E' Ring 3M	6-1-9	5						
10-19	ZG288865	Direction Spring	CQ-1092	1						
10-20	ML268975	Play Lever Part CQ	CQ-1046	1						
10-21	TC268964	Brake Slide Part CQ	CQ-1047	1						
10-22	ZG456120	Setting Lever Spring	CS-1187	1						
10-23	ZW317171	Washer (PBP) D3.1x8x0.1t		3						
10-24	ZW270088	'E' Ring 1.9M	6-1-9	10						
10-25	MZ217473	RWD Slide	CQ-1054	1						
10-26	ML641823	RWD Lever	CA-1066	1						
10-27	ML268953	RWD Lever (Q) Part CQ	CA-1067	1						
10-28	ZG286918	FF Joint Spring	CQ-1090	2						
10-29	ML268942	Idler Lever Part CQ	CQ-1055	1						
10-30	ML301318	Idler Lever (B) Part CQ	CQ-1055	1						
10-31	ML280596	FF Joint Lever Part CQ	CQ-1052	1						
10-32	ML221220	FF Lever Part CA	CA-1056	1						
10-33	ZG469315	Take-up Lever Spring	CG-1091	1						
10-34	ML684573	FF Wind Arm Part CA	CA-1060	1						
10-35	ZW645952	Washer (Teflon) D2.1x4x0.2t		2						
10-36	MI644804	FW Wheel CA	CA-1063	1						
10-37	ZW356657	'E' Ring 1.5M	6-1-9	1						
10-38	ZG385986	Safety Lever Return Spring	CS-2539	1						
10-39	ML217170	Brake Lever A	CQ-1049	1						
10-40	ML217181	Brake Lever B	CQ-1049	1						
10-41	ZG580263	Lock Plate B Spring	TD-2016	1						
10-42	ML269818	Joint Arm Part CQ	CQ-1050	2						
10-43x	ZW259885	Washer (PBP) D5.1x10.3x0.1t		1						
10-44	TC641801	Wind Lever Resetter	CA-1064	1						
10-45	ZS462802	Tapping Screw #2, 3x15 (BR)		1						
10-46	MZ217236	FF Connecting Plate	CQ-1051	1						
10-47	MZ217416	RWD Connecting Plate	CQ-1053	1						
10-48	ZW407362	Washer (Nylon) D3.1x5x1t		2						
10-49	ZW420682	Washer (Nylon) D4.2x9x0.5t		1						
10-50	MZ217135	Play Connection Plate	CQ-1045	1						
10-51	ZG644848	PR Spring	CA-1081	1						
10-52	ML216922	Detector Lever 1	CQ-1031	1						
10-53	ML216933	Detector Lever 2	CQ-1032	1						
10-54	ML280675	Holder Lever Part CQ	CQ-1033	1						
10-55	MZ216955	Cassette Holder	CQ-1034	1						
10-56	ZG365433	Idler Tension Spring	RCC-1365	1						
10-57	ZG230782	SW. Base Return Spring	CQ-1081	1						
10-58	ZG262282	Spring, holder	CQ-1086	1						
10-59	ZG392848	Operation Lever Spring	CS-2102	1						
10-60	ES477966	Micro SW. SS-5GL	25-1-23	1						
10-61	ZS487091	Screw, pan head 2.3x8		2						
10-62	MZ216843	Eject Slide 2	CQ-1028	1						
10-63	MZ217078	Idler Changing Lever	CQ-1041	1						
10-64x	ZW416698	Nut M4		2						
10-65	BL211713	Take-up Lever Block Comp. CQ	CG-1844	2						

RTV servis Horvat
Kešinci, 31402 Semeljci
Tel : 031-856-637
Tel / fax : 031-856-139
Mob : 098-788-319
rty-servis-horvat@os.tel.hr

11. ILLUSTRATION OF MECHA FRAME BLOCK (3)

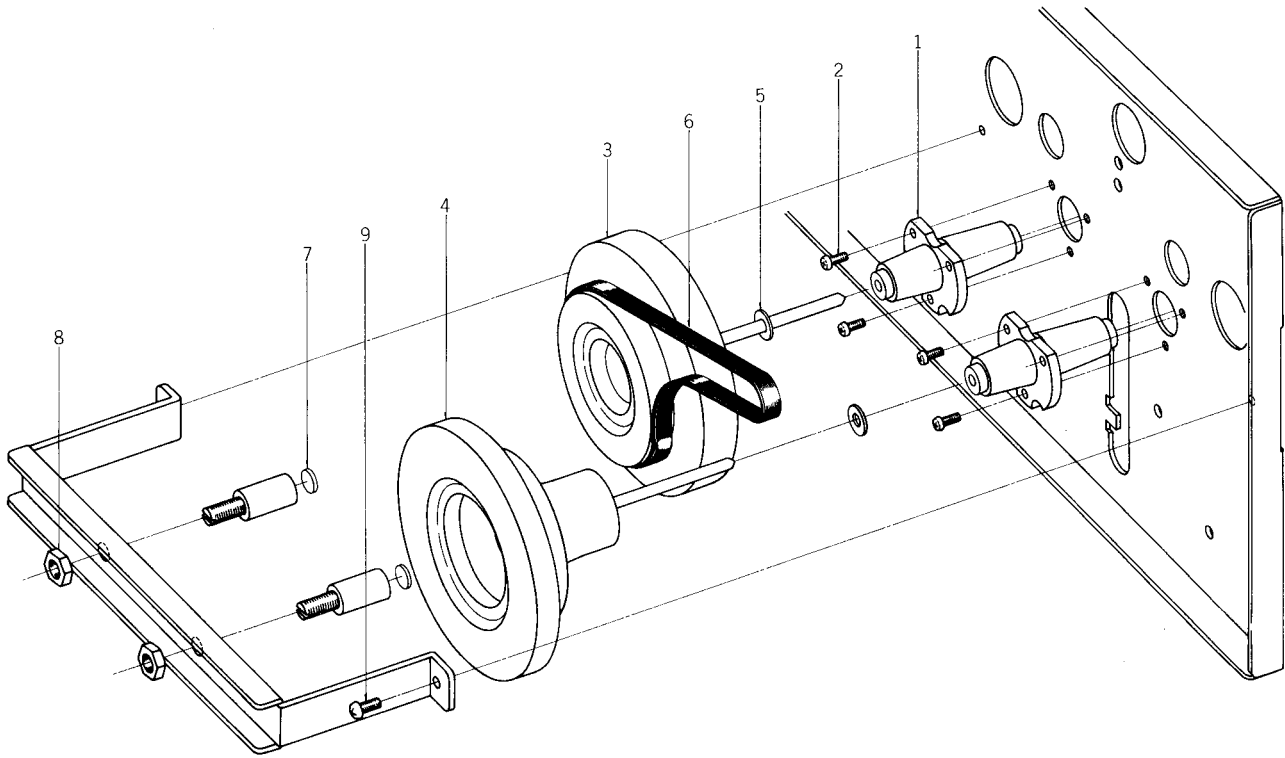

11) MECHA FRAME BLOCK (3)

Ref. No.	Parts No.	Description	Schematic No.	Q'ty
11-1	MZ674616	Capstan Metal Case Part CA	CA-1041	2
11-2	ZS499331	Screw, pan head 2.3x5		6
11-3	MI217754	Flywheel A CQ	CQ-1072	1
11-4	MI217765	Flywheel B CQ	CQ-1073	1
11-5	ZW301751	Thrust Washer (Nylon)	CQ-1099	2
11-6	MB217776	Capstan Belt	CQ-1074	1
11-7	TC653220	Capstan Shaft Holder	CH-1079	1
11-8	ZW668452	Metal Nut	7-1-64	2
11-9	ZS325495	Tapping Screw #2, 3x6(BR)		2

12. P.C BOARDS

(1) PRE AMP P.C BOARD (CQ-5015) BLOCK

Symbol No.	Parts No.	Description	Schematic No.	Q'ty
(1)-1	BA211972	Pre Amp P.C Board Comp. (CQ-5015)	CQ-9851	
			AtoD	1
(1)-IC1	EI605013	IC NE545B	45-8-117	2
(1)-TR1to3	ET391768	Transistor 2SC458LG(C)(D)	45-1-29	6
(1)-TR4	ET403402	Transistor 2SC536(G)	45-1-55	2
(1)-TR5to9	ET635231	Transistor 2SC536(F)(G)	45-1-55	10
(1)-TR10,11	ET638504	Transistor 2SC945L(P)	45-1-85	2
(1)-D1to3	ED219464	Germanium Diode 1N34A	45-3-1	6
(1)-D4to12	ED560913	Silicon Diode 1S2473VE	45-3-23	18
(1)-FL1	ER669734	MPX Filter FB1801M	53-1-104	2
(1)-T1	BT490702	Headphone Trans. N19-349S	38-2-32	2
(1)-VR1	EV464196	Semi-fixed/Vol. V8K4-1 2 kB	36-10-266	2
(1)-VR2	EV522797	Semi-fixed/Vol. V8K4-1 20 kB	36-10-266	2
(1)-VR3	EV464196	Semi-fixed/Vol. V8K4-1 2 kB	36-10-266	2
(1)-VR4	EV497698	Semi-fixed/Vol. V10K8-1-5		
		20 kB (4US)	36-10-252	2
(1)-L1	EO368403	Ferri Inductor FL9H 33MH(J)	23-1-4	2
(1)-L2,3	EO663748	Inductor RCP-095 36MH(J)	23-1-245	4
(1)-SW1	ES494076	Slide SW. CL-109B	25-3-78	2
(1)-SW2	ES494302	Slide SW. CL104B	25-3-79	1
(1)-R60	ER658034	Metal Oxide Film/R. 2W 220 ohms(J)	35-15-18	1
(1)-C3	EC516723	Styrol/C. (Vert. Type) 270PF(K) 50WV	24-11-3	2
(1)-C4	EC516767	Styrol/C. (Vert. Type) 470PF(K) 50WV	24-11-3	2
(1)-C15	EC619650	Solid Aluminum/C. (Vert. Type) 0.1μF(K) 25WV	24-19-2	2
(1)-C26	EC619650	Solid Aluminum/C. (Vert. Type) 0.1μF(K) 25WV	24-19-2	2
(1)-C27	EC604102	Solid Aluminum/C. (Vert. Type) 0.33μF(K) 25WV	24-19-2	2
(1)-C35	EC487157	NP/C. (Vert. Type) 0.47μF(M) 50WV	24-17-17	2

(2) OSC, POWER SUPPLY P.C BOARD (CQ-5011) BLOCK

Symbol No.	Parts No.	Description	Schematic No.	Q'ty
(2)-1	BA211994	Osc, Power Supply P.C Board Comp. (CQ-5011)	CQ-9751A/B	1
(2)-2	BA235552	Osc, Power Supply P.C Board Comp. (CQ-5011) (CEE)	CQ-9751A/B	1
(2)-3	BA235563	Osc, Power Supply P.C Board Comp. (CQ-5011) (CSA)	CQ-9751A/B	1
(2)-4	BA235574	Osc, Power Supply P.C Board Comp. (CQ-5011) (JPN)	CQ-9751A/B	1
(2)-TR1,2	ET622080	Transistor 2SC1175(E)(F)	45-1-195	2
(2)-TR3	ET537300	Transistor 2SD361(D)(E)	45-1-143	1
(2)-TR4	ET399870	Transistor 2SC711(G)	45-1-67	1
(2)-L1	EO682367	Ferri Inductor FS1215S-471JR20	23-1-253	1
(2)-VR1,2	EV550023	Semi-fixed/Vol. V10K8-4-2 100 kB	36-10-250	2
(2)-VR3	EV560103	Semi-fixed/Vol. V10K8-4-2 100ohmsB	36-10-250	1
(2)-T1	EO620482	OSC Coil OT-925	23-4-31	1
(2)-RL1to3	EP616500	Relay LC1-C-JT DC24V	47-1-22	3
(2)-CR1to4	ER376435	Spark Quencher U/L 0.1μ+120 ohms 250WV	41-1-35	4
(2)-D1to4	ED494583	Silicon Diode 10D05	45-2-42	4
(2)-D5	ED511918	Zener Diode WZ-240	45-6-67	1
(2)-D6to10	ED560913	Silicon Diode 1S2473VE	45-3-23	5
(2)-D11to14	ED224550	Silicon Diode 10D4	45-2-16	4
(2)TH1	ED560147	Thermister (Special) 100PD-81 B9220	45-14-2	1
(2)-R5	ER266433	Fuse/R. FRN30MA68 ohms(K)	35-14-16	1
(2)-R6	ER266444	Metal Oxide Film/R. 3W 200 ohms(J)	35-15-19	1
(2)-R14	ER563253	Cement/R. (Wire-wound Type) 3W 2.2 ohms(K)	35-16-2	1
(2)-C1,2	EC289451	Styrol/C. (w/rubber) 100PF(J) 50WV	24-11-13	2
(2)-C3	EC520468	Styrol/C. (Tub. Type) 3300PF(J) 500WV	24-11-10	1
(2)-C12,13	EC242730	Metalized Film/C. 0.1μF 220WV (Vert. Type)	24-16-9	2
(2)-5	ZS421806	Screw, pan head 3x8		1
(2)-6	ZW516611	Nut M3		1
(2)-7	ZS558101	Screw, pan head 3x6 w/washer		1
(2)-8	ZS422076	Screw, pan head 3x5		1

**(3) REVERSE MODE P.C BOARD (CQ-5023)
BLOCK**

Symbol No.	Parts No.	Description	Schematic No.	Q'ty
(3)-1	BA212040	Reverse Mode P.C Board Comp. (CQ-5023)	CQ-9756	1
(3)-SW1	ES677305	Lever SW. SLE54305	25-12-24	1

(4) SYS. CON P.C BOARD (CQ-2001) BLOCK

Symbol No.	Parts No.	Description	Schematic No.	Q'ty
(4)-1	BA211768	Sys. Con P.C Board Comp. (CQ-2001)	CQ-9752	1
(4)-TR1to3	ET635231	Transistor 2SC536(F)(G)	45-1-55	3
(4)-TR4	ET375603	Transistor 2SC1061(B)(C)	45-1-96	1
(4)-TR5	ET635231	Transistor 2SC536(F)(G)	45-1-55	1
(4)-TR6	ET666404	Transistor 2SD571(K)(L)	45-1-218	1
(4)-TR7	ET635231	Transistor 2SC536(F)(G)	45-1-55	1
(4)-TR8	ET666404	Transistor 2SD571(K)(L)	45-1-218	1
(4)-TR9to14	ET635231	Transistor 2SC536(F)(G)	45-1-55	6
(4)-D1to34	ED560913	Silicon Diode 1S2473VE	45-3-23	34
(4)-C1	EC516712	Styrol/C. (Vert. Type) 220PF(K) 50WV	24-11-3	1

13. ILLUSTRATION OF AMP ASSEMBLY BLOCK

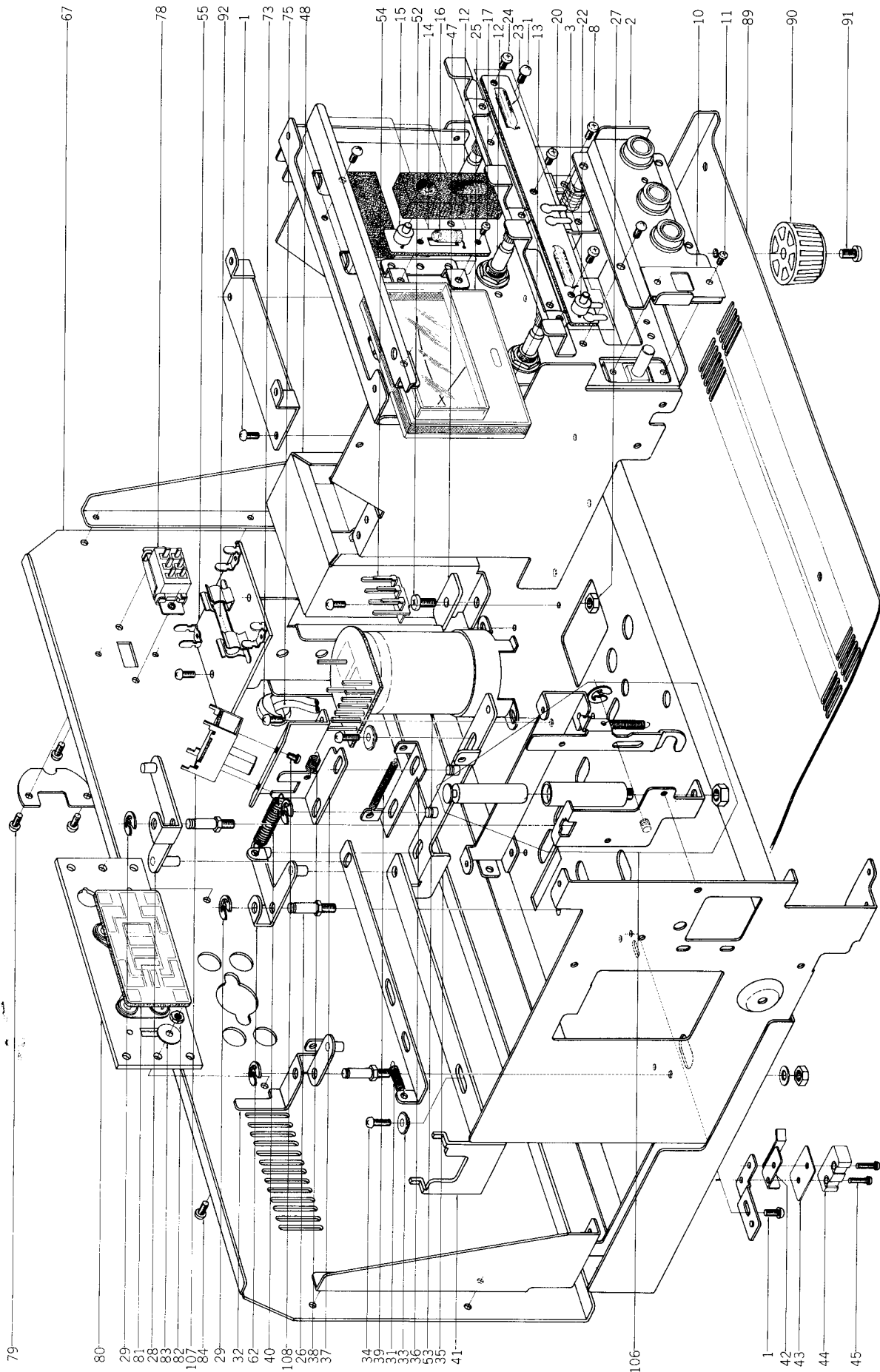

13) AMP ASSEMBLY BLOCK

Ref. No.	Parts No.	Description	Schematic No.	Q'ty	Ref. No.	Parts No.	Description	Schematic No.	Q'ty
VU METER BASE BLOCK									
13-1	ZS325495	Tapping Screw #2, 3x6 (BR)		55	13-57x	EJ232233	3P Fuse Holder (Small) (CEE, BEAB)	40-175	1
13-2	EJ250751	Mic Jack Assy CQ	CQ-9722	1	13-58x	EJ232176	2P Fuse Holder (Large) CQ (CSA, AAL, JPN)	40-195	1
13-3	ES665875	Push SW. SDG-1P U/L	25-5199	1	13-59x	EZ652410	Fuse Holder 3P Table (CSA, AAL, JPN)	40-1-68	1
13-4x	ES665807	Push SW. SDG-5P (CEE)	25-5182	1	13-60	TC668024	Fuse Base	CB 5017	1
13-5x	EC699298	PE-9P Film/C. 0.1μF(K) 600WV	24-3-8	1	13-61x	TC668024	Fuse Base (CEE, BEAB, CSA, AAL, JPN)	CB 5017	2
13-6x	EC565896	Ceramic/C. DP6600YM 0.01μF(P) 1.4 kWV(CSA)	24-5-58	1	13-62	ML281957	Rec Lever (2) Part CQ	CQ-5026	1
13-7x	EC256950	MP/C. PEM271 0.01μF 250WV (CEE)	24-9-118	2	13-63x	ZS379350	Screw, pan head 3x6		2
13-8	ZS379350	Screw, pan head 3x6		4	13-64x	ZW563218	Washer (Bake) D3.2x10x1t		3
13-9x	ZW562476	Earth Lug M3		1	13-65x	EZ300315	Trans. Shield (CEE, BEAB)	CQ-5039	1
13-10	TC241424	Mask	CQ-5030	1	13-66x	EZ300553	P.C Board Barrier (CEE, BEAB)	CQ-5041	1
13-11	ZS432843	Screw, pan head 2.6x4		2	13-67	SP219025	Rear Panel A	CQ 5017	1
13-12	EV691468	Vol. VJ10R670 50 kA	36-2-41	2	13-68x	SP219036	Rear Panel B (CEE)	CQ 5017	1
13-13	EV231017	Single axial 2 throw Vol. GJ70R526-10 kBx2	36-1-47	1	13-69x	SP288213	Rear Panel D (JPN)	CQ-5017/5036	1
13-14	EA234180	LED P.C Board	CQ-5021	1	13-70x	SP300260	Rear Panel F (CSA)	CQ 5016/5038	1
13-15	ED656357	LED SEL-105R	45-15-11	1	13-71x	SP288202	Rear Panel C (AAL)	CQ-5017/5036	1
13-16	EL603268	Lamp (L/T) 24V 35 mA	28-2-39	1	13-72x	SP288224	Rear Panel E (BEAB)	CQ-5017/5037	1
13-17	ZS417161	Screw, pan head 2.3x4		2	13-73	EZ631945	Strain Relief SR-4N-4	2-7-49	1
13-18	TC219183	Shield Plate	CQ-5020	1	13-74x	EZ246936	Strain Relief (CEE) SR-6W-1	2-7-8	1
13-19x	ZW259424	Lug Plate, D6 wrapping	33-5-10	1	13-75	EW604618	AC Cord VM-0064 (U/T, CEE)	26-3-34	1
13-20	BA262383	Lamp P.C Board Assy CQ	CQ-9717	1	13-76x	EW516475	AC Cord (CSA, AAL)	26-3-20	1
13-21	EA234191	Lamp P.C Board B	CQ-5022	1	13-77x	EW557640	AC Cord 2.5M (JPN)	26-3-32	1
13-22	ED656346	LED 305GC	45-15-10	1	13-78	ES479485	Slide SW. S-1	25-3-66	1
13-23	EL295312	Lamp (L/T) 8V 0.2A	28-2-8	2	13-79	ZS201150	Screw, truss head 3x6 (Black)		2
13-24	ZS422076	Screw, pan head 3x5		7	13-80	EJ624104	Jack Plate J-2	31-5-121	1
13-25	EM234134	VU Meter KL-250L-10	46-1-138	2	13-81	EA647313	Jack Plate P.C Board	LE-5626	1
AMP CHASSIS BLOCK									
13-26	MS645017	Rec Lever Shaft	CA 5020	3	13-82	ZW273756	Nut M3, #1		2
13-27	ZW413267	Flange Nut M4		5	13-83	ZW556828	Washer (SPC) D3.5x10x0.5t		2
13-28	ML281924	Reverse Change Lever (B) Part CQ	CQ 5008	1	13-84	ZS355522	Screw, pan head 3x6		2
13-29	ZW290283	'U' Ring 2.85M	6-1-1	5	ASSEMBLY BLOCK				
13-30	MZ218902	Rev. Changing Slide	CQ 5006	1	13-85x	ZS469710	MR Graduated Screw	MR-254	1
13-31	ZG470430	SST Spring B	RCC-1240B	1	13-86x	ZS447761	Tapping Screw #2, 3x6 (BR) (Black)		10
13-32	ML281935	Reverse Change Lever (A) Part CQ	CQ 5007	1	13-87x	ZW553915	Washer D3.5x10x1t		3
13-33	ZW628288	Graduated Collar	LE-5602	6	13-88x	BA211746	SW. P.C Board Comp. CQ	CQ-9760A/B	1
13-34	ZS447840	Tapping Screw #2, 3x8 (BR)		2	13-89	SP219442	Bottom Plate	CQ 6007	1
13-35	TC281946	Rec Slide (B) Part CQ	CQ-5004	1	13-90	SZ645243	Circular Foot A CA	CA 6014	4
13-36	MZ218867	Rec Slide	CQ-5002	1	13-91	ZS417150	Screw, pan head 4x6		4
13-37	MZ218891	Rec Slide C	CQ-5005	1	13-92	EF590692	Fuse 1.2A 250V	39-1-50	1
13-38	ZG525993	SW. Return Spring	CV 2060	1	13-93x	EF601964	Fuse (SEMKO T Type) 1.6AT	39-1-53	1
13-39	ZG359515	FF Slide Lever Spring	PX-134	1	13-94x	EF602550	Fuse (SEMKO T Type) 1.25AT 250V	39-1-53	1
13-40	ZG369606	Field Lever Spring	RCC 110	1	13-95x	EF623103	Fuse (SEMKO T Type) 1AT (CEE, BEAB)	39-1-53	1
13-41	MZ218878	Rec Slide A	CQ-5003	1	13-96x	EF258344	Fuse (SEMKO T Type) 800mAT (CEE, BEAB)	39-1-53	2
13-42	EZ280765	Actuator	CQ-0021	1	13-97x	EF662534	Fuse ULMF61M 250V 2.5A (CSA, AAL)	39-1-45	1
13-43	EZ595653	Insulator Plate	CH-1055	1	13-98x	EF511626	Fuse ULMF61M 250V 0.8A (CSA, AAL)	39-1-45	1
13-44	ES389700	Micro SW. SS-5	25-1-19	1	13-99x	EF550618	Fuse ULMF61M 250V 1.5A (CSA, AAL)	39-1-45	1
13-45	ZS465298	Screw, pan head 2.3x10		2	13-100x	EF668610	Fuse ULMF61M 250V 1.2A (CSA, AAL)	39-1-45	2
13-46x	ZW562476	Earth Lug M3		1	13-101x	EF562691	Fuse 2.5A 250V (JPN)	39-1-50	1
13-47	EZ486617	Trans. Reinforcement Plate B	LF-5222	2	13-102x	EF575932	Fuse 0.8A 250V (JPN)	39-1-50	1
13-48	BT230984	Power Trans. CQT-1	38-4-427	1	13-103x	EF563692	Fuse 1.5A 250V (JPN)	39-1-50	1
13-49x	BT232165	Power Trans. CQT-3 (CEE, BEAB)	38-4-429	1	13-104x	EF590692	Fuse 1.2A 250V (JPN)	39-1-50	2
13-50x	BT232143	Power Trans. CQT-2 (CSA, AAL, JPN)	38-4-428	1	13-105x	MZ284005	Barrier (AAL)	CQ-6016	1
13-51x	EZ300552	Fuse Barrier (CSA, AAL, JPN)	CQ 5040	1	13-106	BZ681941	Damper Block Comp. CB	CB-2045	1
13-52	ZS413201	Screw, pan head 4x8		4	13-107	ES422414	Slide SW. SL-242B4BD	25-3-39	1
13-53	EC684472	Elect./C. (Wrapping Type) 330μF 160WV	24-10-108	1	13-108	ZS432843	Screw, pan head 2.6x4		2
13-54	EJ551035	Wrapping Terminal, 4P T-5251	32-1-36	1					
13-55	EJ230995	1P Fuse Holder (Large) CQ	40-1-94	1					
13-56x	EJ232187	2P Fuse Holder (Small) CQ (CEE, BEAB)	40-1-96	1					

When ordering parts, Please describe Parts Number, Description, and Model Number in detail.

14. PHOTO OF FINAL ASSEMBLY BLOCK

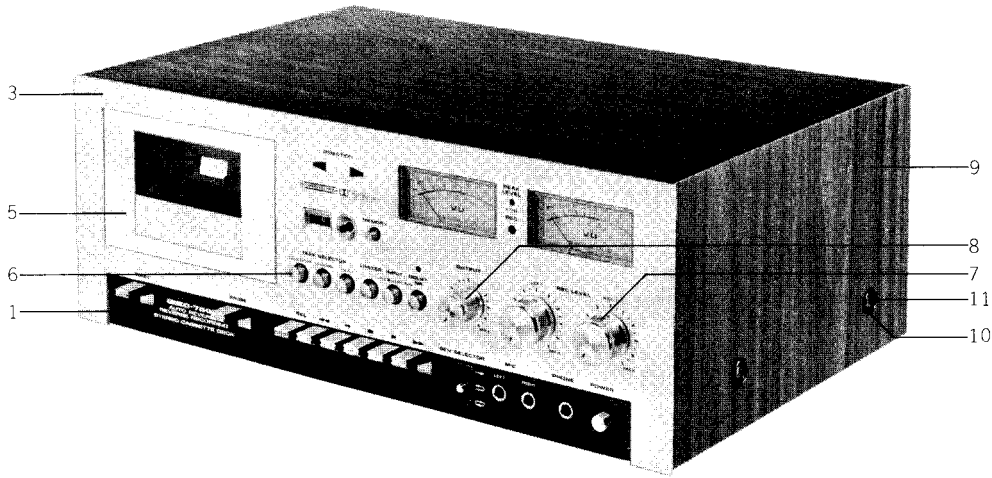

14) FINAL ASSEMBLY BLOCK

Ref. No.	Parts No.	Description	Schematic No.	Q'ty
14-1	BD211634	Operation Panel Block		
		Comp. CQ	CG-6829	1
14-2x	ZS325495	Tapping Screw #2, 3x6(BR)		3
14-3	BD211645	Front Panel Block Comp. CQ	CQ-9715	1
14-4x	ZS447840	Tapping Screw #2, 3x8(BR)		8
14-5	BD681491	Lid Panel Block Comp.		
		CA2, CB	CB-6008	1
14-6	SB645232	Selector Button	CA-6011	6
14-7	SK631056	Single Knob CW	MY-6208	2
14-8	SK219497	Single Knob CQ	CQ-6009	1
14-9	BC219453	Wood Frame	CQ-6008	1
14-10	ZW548010	Spot Facing Washer	MU-6028	4
14-11	ZS510344	Screw, binding head 4x12		4

15. LIST OF INTERCHANGEABLE SEMICONDUCTORS

As far as service in concerned, in case the original parts cannot be obtained, the interchangeable parts listed below can be substituted.

Original Parts			Interchanbeable Parts	
Description	Parts No.	Utilizing P.C Board	Description	Parts No.
2SC458LG (C) (D)	ET391763	CQ-5015	2SC458 (C) 2SC693U (F)	ET329218 ET315472
2SC711 (G)	ET399870	CQ-5011	2SC945L (P) (Q) 2SC1647 (R) (S) (E)	ET639437 ET623733
2SC945L (P) (Q)	ET639437	CQ-2001 CQ-2012 CQ-5015	2SC711 (E) (F) 2SC536 (F) (G)	ET453486 ET635231
2SC1061 (B) (C)	ET375603	CQ-2001	2SD361 (D) (E) 2SC1449 (K) (L) (M)	ET537300 ET635815
2SC1175 (E) (F)	ET622080	CQ-5011	2SC1211 (E) (F)	ET666393
2SD361 (D) (E)	ET537300	CQ-5011	2SC1098 (L) (M)	ET476886
2SD571 (K) (L)	ET666404	CQ-2001		
1N34A	ED219464	CQ-5015	1N60 1S188AM	ED428264 ED562386
1S2473VE	ED560913	CQ-5015 CQ-5011 CQ-2001	1S2473 WG599	ED624903 ED514721
10D05	ED494583	CQ-5011	1N4001	ED538615
10D4	ED224550	CQ-5011	1N4004	ED570273
WZ240	ED511918	CQ-5011	RD24A	ED229072
SEL105R	ED650357			
SEL305GC	ED656346			
NE545B	EI605013			

INDEX

Parts No.	Ref. No. & Symbol No.	Parts No.	Ref. No. & Symbol No.	Parts No.	Ref. No. & Symbol No.	Parts No.	Ref. No. & Symbol No.	Parts No.	Ref. No. & Symbol No.
BA211746	13-88x	EJ250751	13-2	HZ268896	2-44	MZ217530	9-2	ZG369606	13-40
BA211768	(4)-1	EJ551035	13-54	HZ294524	2-33	MZ217541	9-4	ZG385986	10-38
BA211803	10-72	EJ624104	13-80	HZ567202	2-5	MZ217574	10-4	ZG387178	5-8
BA211972	(1)-1	EL231254	10-68	HZ567213	2-39	MZ217675	10-69	ZG392848	10-59
BA211994	(2)-1	EL231265	10-67	MB217776	11-6	MZ218057	7-13	ZG402895	2-40
BA212040	(3)-1	EL295312	6-33	MB217787	10-66	MZ218586	5-4	ZG422223	5-18
BA235552	(2)-2	EL295312	13-23	MB666123	4-20	MZ218621	5-5	ZG456120	5-14
BA235563	(2)-3	EL603268	13-16	MC213085	10-1	MZ218643	5-17	ZG456120	10-22
BA235574	(2)-4	EM234134	13-25	MH257477	7-9	MZ218711	5-10	ZG469315	10-33
BA262383	13-20	EO368403	(1)-L1	MH533913	7-11	MZ218867	13-36	ZG470430	13-31
BC219453	14-9	EO620482	(2)-T1	MH620572	10-9	MZ218878	13-41	ZG514440	8-4
BD211634	14-1	EO663748	(1)-L2,3	MH644916	6-25	MZ218891	13-37	ZG525993	13-38
BD211645	14-3	EO682367	(2)-L1	MH664064	6-18	MZ218902	13-30	ZG577945	8-11
BD681491	14-5	EP263136	7-5x	ML217754	11-3	MZ219510	4-1	ZG580263	10-41
BH286637	2-1x	EP494425	10-5	ML217765	11-4	MZ284005	13-105x	ZG595618	6-8
BK218812	5-19	EP616500	(2)-RL1to3	ML644804	10-36	MZ646290	4-8	ZG595620	6-9
BL211713	10-65	EP638695	7-4	ML678633	9-24	MZ674616	11-1	ZG644848	10-51
BM571904	4-9	EP638706	7-1	ML204862	6-21	MZ678508	9-28	ZS201150	13-79
BR211691	3-2	ER266433	(2)-R5	ML216371	2-45	SB645232	14-6	ZS201936	2-12
BR211702	3-1	ER266444	(2)-R6	ML216393	2-15	SK219497	14-8	ZS290496	4-12
BT230984	13-48	ER376435	(2)-CR1to4	ML216810	9-13	SK631056	14-7	ZS300626	2-30x
BT232143	13-50x	ER563253	(2)-R14	ML216922	10-52	SP219025	13-67	ZS323728	7-2
BT232165	13-49x	ER658034	(1)-R60	ML216933	10-53	SP219036	13-68x	ZS325495	4-4
BT490702	(1)-T1	ER669734	(1)-FL1	ML217091	10-12	SP219442	13-89	ZS325495	5-13
BZ211860	6-1x	ES389700	13-44	ML217170	10-39	SP288202	13-71x	ZS325495	6-36
BZ211893	8-13	ES422414	13-107	ML217181	10-40	SP288213	13-69x	ZS325495	9-11
BZ211904	8-1	ES477966	9-9	ML217552	10-8	SP288224	13-72x	ZS325495	10-14
BZ681568	9-1	ES477966	9-21	ML221220	10-32	SP300260	13-70x	ZS325495	11-9
BZ681941	13-106	ES477966	10-60	ML268727	7-10	SZ645221	10-76	ZS325495	13-1
EA219600	2-19	ES479485	13-78	ML268762	7-7	SZ645243	13-90	ZS325495	14-2x
EA234180	13-14	ES488970	9-7	ML268773	7-15	TC203815	6-24	ZS355522	13-84
EA234191	13-21	ES494076	(1)-SW1	ML268918	5-1	TC216382	2-3	ZS356861	2-8
EA234246	6-32	ES494188	5-11	ML268920	5-2	TC219183	13-18	ZS364397	8-8
EA647313	13-81	ES494188	8-7	ML268931	9-15	TC241424	13-10	ZS375107	2-38
EC242730	(2)-C12,13	ES494302	(1)-SW2	ML268942	10-29	TC268841	5-7	ZS379350	2-24
EC256950	13-7x	ES516036	10-3	ML268953	10-27	TC268874	2-26	ZS379350	4-11x
EC289451	(2)-C1,2	ES558944	10-73	ML268975	10-20	TC268885	2-22	ZS379350	5-22
EC487157	(1)-C35	ES665807	13-4x	ML268997	10-10	TC268964	10-21	ZS379350	13-8
EC516712	(4)-C1	ES665875	13-3	ML269010	9-12	TC268986	10-17	ZS379350	13-63x
EC516723	(1)-C3	ES677305	(3)-SW1	ML269021	10-15	TC280620	10-70	ZS391522	5-12
EC516767	(1)-C4	ET375603	(4)-TR4	ML269818	10-42	TC280664	6-37	ZS399148	2-31
EC520468	(2)-C3	ET391768	(1)-TR1to3	ML280596	10-31	TC281946	13-35	ZS413201	13-52
EC565896	13-6x	ET399870	(2)-TR4	ML280631	10-71	TC293174	2-20	ZS414033	6-26
EC604102	(1)-C27	ET403402	(1)-TR4	ML280653	9-19	TC384164	4-7	ZS417150	13-91
EC619650	(1)-C15	ET537300	(2)-TR3	ML280675	10-54	TC394075	4-16x	ZS417161	2-10x
EC619650	(1)-C26	ET622080	(2)-TR1,2	ML281924	13-28	TC515575	8-3	ZS417161	2-21
EC641338	4-2	ET635231	(1)-TR5to9	ML281935	13-32	TC641801	10-44	ZS417161	6-34
EC641340	4-3x	ET635231	(4)-TR1to3	ML281957	13-62	TC641880	9-23	ZS417161	13-17
EC684472	13-53	ET635231	(4)-TR5	ML301318	10-30	TC642148	6-16	ZS417216	5-21
EC699298	13-5x	ET635231	(4)-TR7	ML595574	6-6	TC642161	5-9	ZS419670	5-20x
ED219464	(1)-D1to3	ET635231	(4)-TR9to14	ML595585	6-7	TC642385	4-15	ZS421806	(2)-5
ED224550	(2)-D11to14	ET635231	10-74x	ML641823	10-26	TC645186	6-13	ZS422076	(2)-8
ED224550	7-6x	ET638504	(1)-TR10,11	ML645377	8-12	TC646920	6-3	ZS422076	2-47
ED494583	(2)-D1to4	ET666404	(4)-TR6	ML683594	2-37	TC647065	6-12	ZS422076	7-3x
ED494583	10-6x	ET666404	(4)-TR8	ML684573	10-34	TC653220	11-7	ZS422076	8-14
ED511918	(2)-D5	EV231017	13-13	MP468292	2-14	TC666156	6-19	ZS422076	10-2
ED560147	(2)-TH1	EV464196	(1)-VR1	MR203804	6-22	TC668024	13-60	ZS422076	13-24
ED560913	(1)-D4to12	EV464196	(1)-VR3	MR281834	4-18	TC668024	13-61x	ZS422965	4-13x
ED560913	(2)-D6to10	EV497698	(1)-VR4	MR281845	4-17	TC684360	6-35	ZS432843	9-8
ED560913	(4)-D1to34	EV522797	(1)-VR2	MS216731	9-20	TC685260	6-2	ZS432843	13-11
ED656346	13-22	EV550023	(2)-VR1,2	MS216821	9-14	ZG207257	6-14	ZS432843	13-108
ED656357	13-15	EV560103	(2)-VR3	MS218114	6-30	ZG216483	2-27	ZS434160	9-25
EF258344	13-96x	EV691468	13-12	MS389981	2-16	ZG216494	2-17	ZS447761	13-86x
EF511626	13-98x	EW516475	13-76x	MS595552	6-5	ZG218790	6-29	ZS447840	13-34
EF550618	13-99x	EW557640	13-77x	MS595563	6-4	ZG227114	2-6	ZS447840	14-4x
EF562691	13-101x	EW604618	13-75	MS644613	9-26	ZG227452	6-27x	ZS455207	4-6x
EF563692	13-103x	EZ246936	13-74x	MS645017	13-26	ZG230051	2-46	ZS460440	10-75
EF575932	13-102x	EZ280765	13-42	MS645153	2-23	ZG230692	2-48	ZS462802	10-45
EF590692	13-92	EZ300315	13-65x	MS645175	5-15	ZG230782	9-5	ZS462947	8-9x
EF590692	13-104x	EZ300552	13-51x	MV250920	2-25	ZG230782	10-57	ZS465298	13-45
EF601964	13-93x	EZ300553	13-66x	MZ216707	9-18	ZG262271	9-6	ZS469710	13-85x
EF602550	13-94x	EZ486617	13-47	MZ216843	10-62	ZG262282	10-58	ZS477876	2-9
EF623103	13-95x	EZ595653	13-43	MZ216955	10-55	ZG262585	9-16	ZS484918	2-41
EF662534	13-97x	EZ631945	13-73	MZ216990	10-16	ZG286918	10-28	ZS487091	9-10
EF668610	13-100x	EZ638965	4-10x	MZ217078	10-63	ZG288865	10-19	ZS487091	9-22
EI605013	(1)-IC1	EZ652410	13-59x	MZ217135	10-50	ZG300828	2-36	ZS487091	10-61
EJ230995	13-55	EZ696431	2-34	MZ217236	10-46	ZG359515	13-39	ZS499331	11-2
EJ232176	13-58x	HE636963	2-4	MZ217416	10-47	ZG365321	6-31	ZS510344	14-11
EJ232187	13-56x	HP571983	2-29	MZ217473	10-25	ZG365321	7-14	ZS558101	(2)-7
EJ232233	13-57x	HZ268784	2-2	MZ217528	9-17	ZG365433	10-56	ZS572804	2-43

INDEX

Parts No.	Ref. No. & Symbol No.	Parts No.	Ref. No. & Symbol No.	Parts No.	Ref. No. & Symbol No.	Parts No.	Ref. No. & Symbol No.	Parts No.	Ref. No. & Symbol No.
ZS592378	10-7								
ZS592402	6-17								
ZS608354	4-19								
ZS666336	5-16								
ZS669104	6-15								
ZW259424	13-19x								
ZW259503	6-23								
ZW259885	10-43x								
ZW270088	2-7								
ZW270088	6-11								
ZW270088	7-12								
ZW270088	8-6								
ZW270088	10-24								
ZW270101	2-32								
ZW270101	5-6								
ZW270101	8-2								
ZW270101	10-18								
ZW273756	13-82								
ZW290283	2-11								
ZW290283	5-3								
ZW290283	6-20								
ZW290283	7-8								
ZW290283	8-10								
ZW290283	9-3								
ZW290283	10-11								
ZW290283	13-29								
ZW301751	11-5								
ZW302332	8-5								
ZW317171	10-23								
ZW318014	2-42								
ZW322110	6-28x								
ZW356657	10-37								
ZW374545	2-28								
ZW391397	2-18								
ZW407362	10-48								
ZW413267	13-27								
ZW416698	10-64x								
ZW420682	10-49								
ZW479294	4-14								
ZW484762	9-27								
ZW516611	(2)-6								
ZW548010	14-10								
ZW553915	13-87x								
ZW556828	13-83								
ZW562476	4-5x								
ZW562476	13-9x								
ZW562476	13-46x								
ZW563218	13-64x								
ZW567630	2-35								
ZW592391	6-10								
ZW628288	13-33								
ZW645952	10-35								
ZW649991	10-13								
ZW668452	11-8								
ZW699052	2-13								

GXC-730D

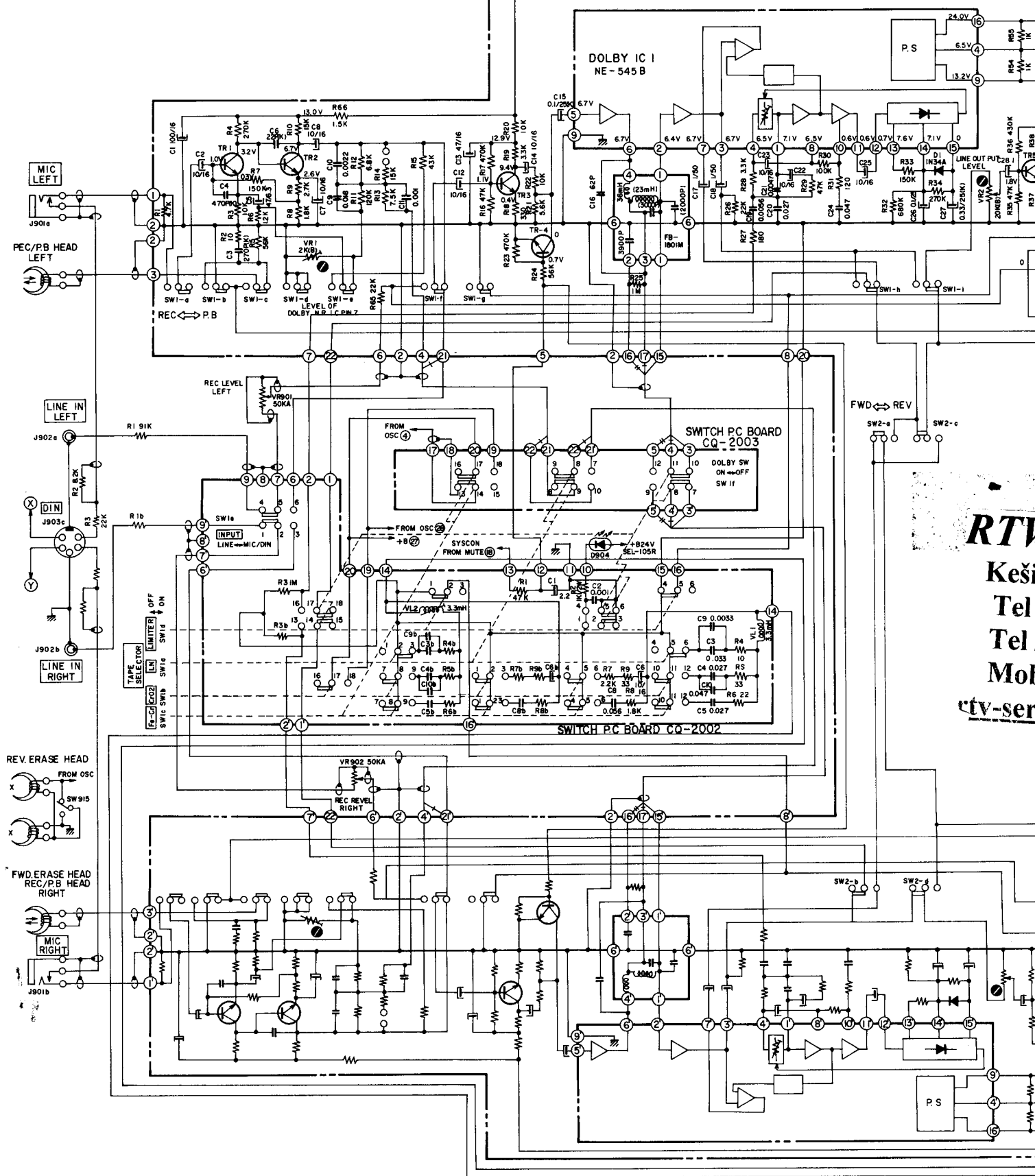

RTV
 Kešić
 Tel.
 Tel.
 Mob.
 rtv-ser

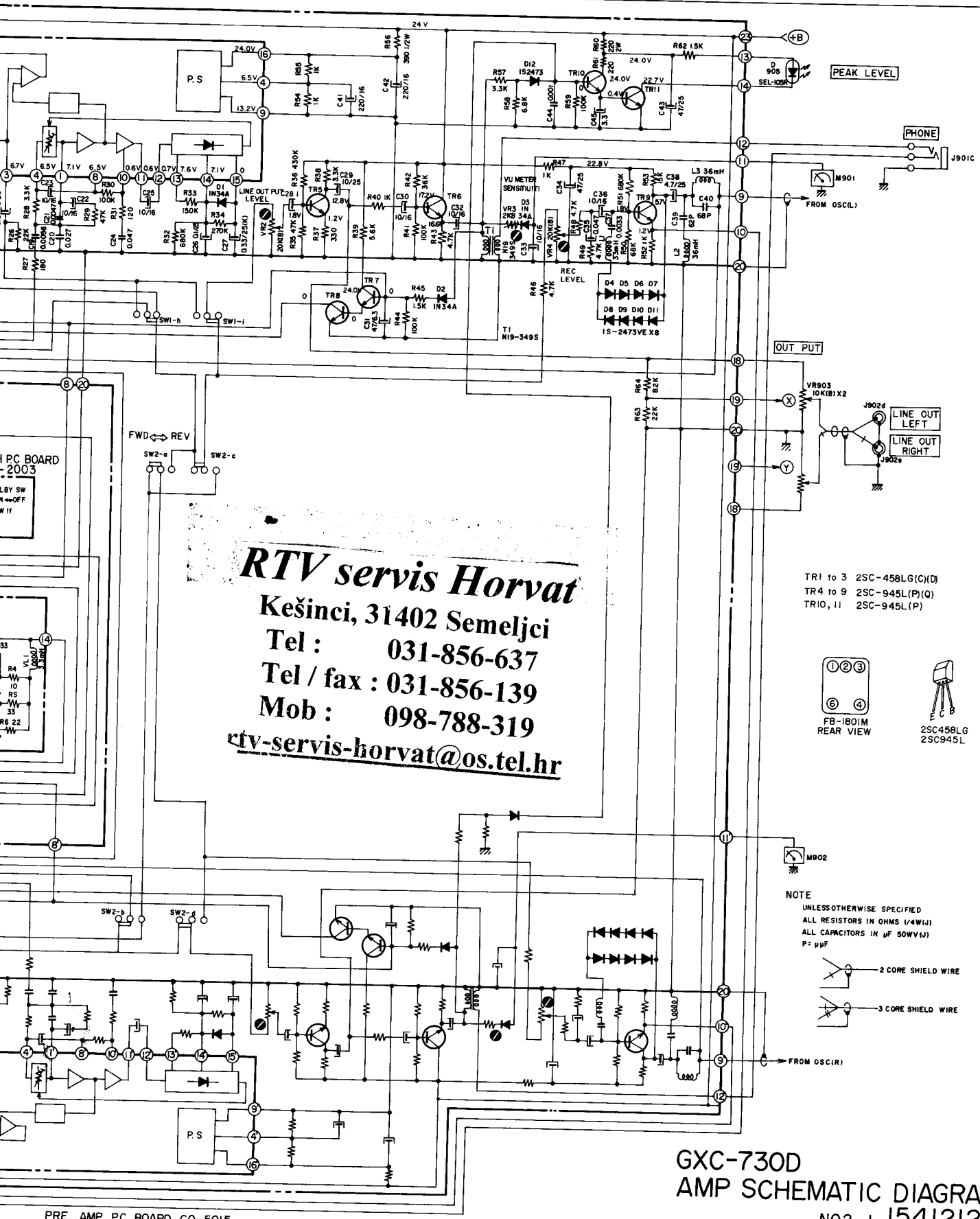

RTV servis Horvat

Kešinci, 31402 Semeljci

Tel : 031-856-637

Tel / fax : 031-856-139

Mob : 098-788-319

rtv-servis-horvat@os.tel.hr

- TR1 to 3 2SC-458LG(C)(D)
- TR4 to 9 2SC-945L(P)(Q)
- TR10, 11 2SC-945L(P)

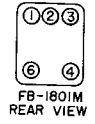

NOTE
 UNLESS OTHERWISE SPECIFIED
 ALL RESISTORS IN OHMS (1/4W/1/)
 ALL CAPACITORS IN μ F 50WV(1/)
 P= μ P

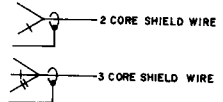

**GXC-730D
 AMP SCHEMATIC DIAGRAM
 N02-1 1541212A**

PRE AMP P.C BOARD CQ-5015

GXC-730D

TRI, TR2 POWER SUPPLY & O.S.C.P.C BOARD			
TAPE SELECTOR	LOW NOISE	CHROME	Fe - Cr
BASE	0 V	-0.2 V	-0.2 V
COLLECTOR	14.4 V	20.0 V	20.0 V
EMITTER	0.1 V	0.1 V	0.1 V
TERMINAL ①	39.0V A.C	51.7V A.C	52.4V A.C
TERMINAL ②	9.8 V A.C	13.8V A.C	17.5V A.C

※	UNI - CSA - JPN	CEE
R5	FV/2 W 68 ohms(J)	FRN30MA68 ohms(K)
R 6	FV/2W200 ohms (J)	3W 200ohms(J)
SL 903	I240PHT	I240PHT1 4

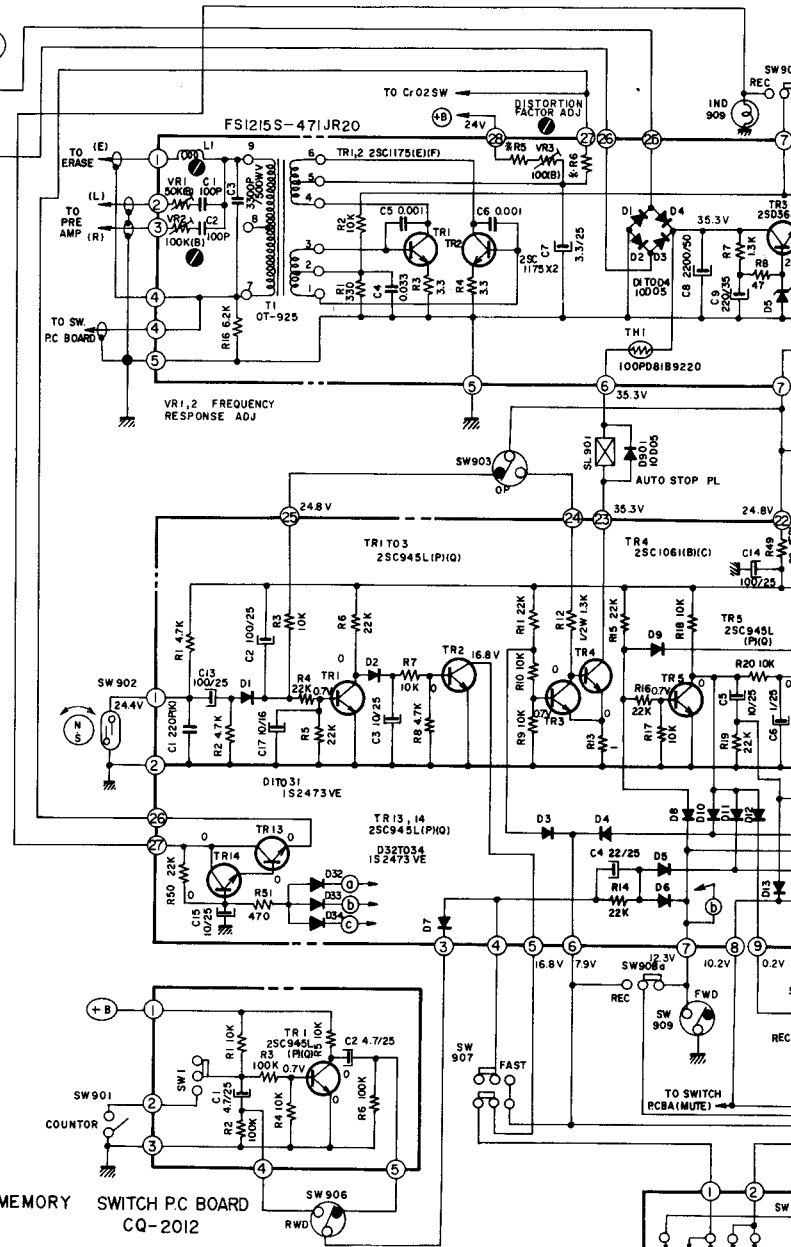
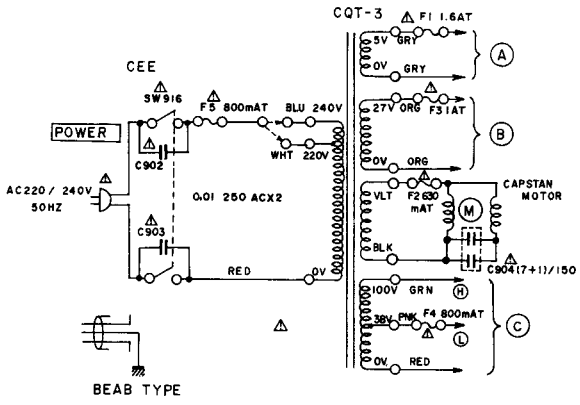
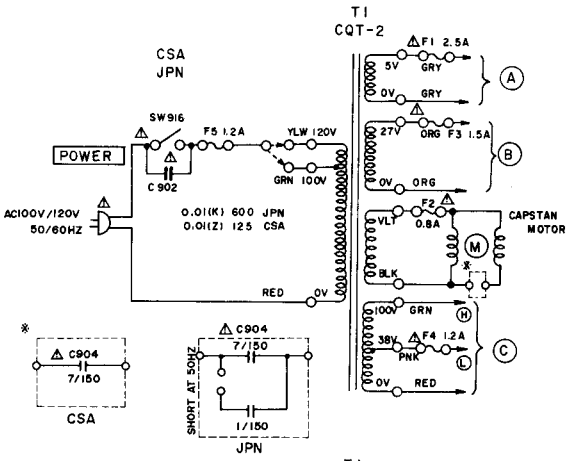
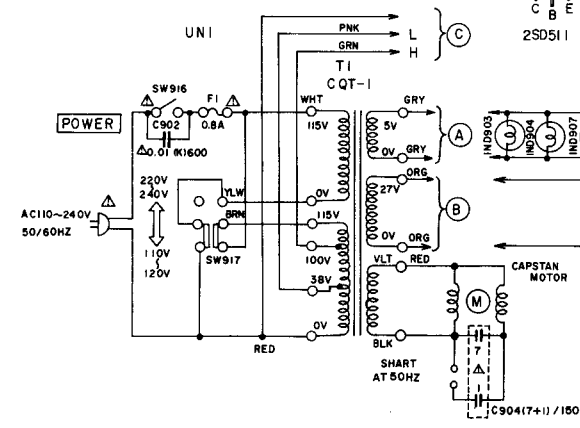
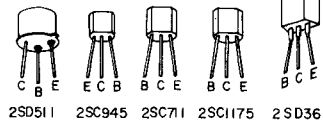

WARNING: Δ INDICATES SAFETY CRITICAL COMPONENTS. FOR CONTINUED SAFETY, REPLACE SAFETY CRITICAL COMPONENTS ONLY WITH MANUFACTURER'S RECOMMENDED PARTS

AVERTISSEMENT: Δ IL INDIQUE LES COMPOSANTS CRITIQUES DE SÛRETÉ. POUR MAINTENIR LE DEGRÉ DE SECURITE DE L'APPAREIL NE REMPLACER LES COMPOSANTS DONT LE FONCTIONNEMENT EST CRITIQUE POUR LA SECURITE QUE PAR DES PIECES RECOMMANDEES PAR LE FABRICANT

SUPPLY & OSC. P.C. BOARD	
CHROME	Fe - Cr
-0.2V	-0.2V
20.0V	20.0V
0.1V	0.1V
51.7V A.C.	52.4V A.C.
13.8V A.C.	17.5V A.C.

×	UNI - CSA - JPN	CEE
R5	F1/2 W 68ohms(J)	FRN30MAG8 ohms(K)
R6	F1/2W200 ohms(J)	3W 200ohms(J)
SL 903	1240PHT	1240PHT1 4

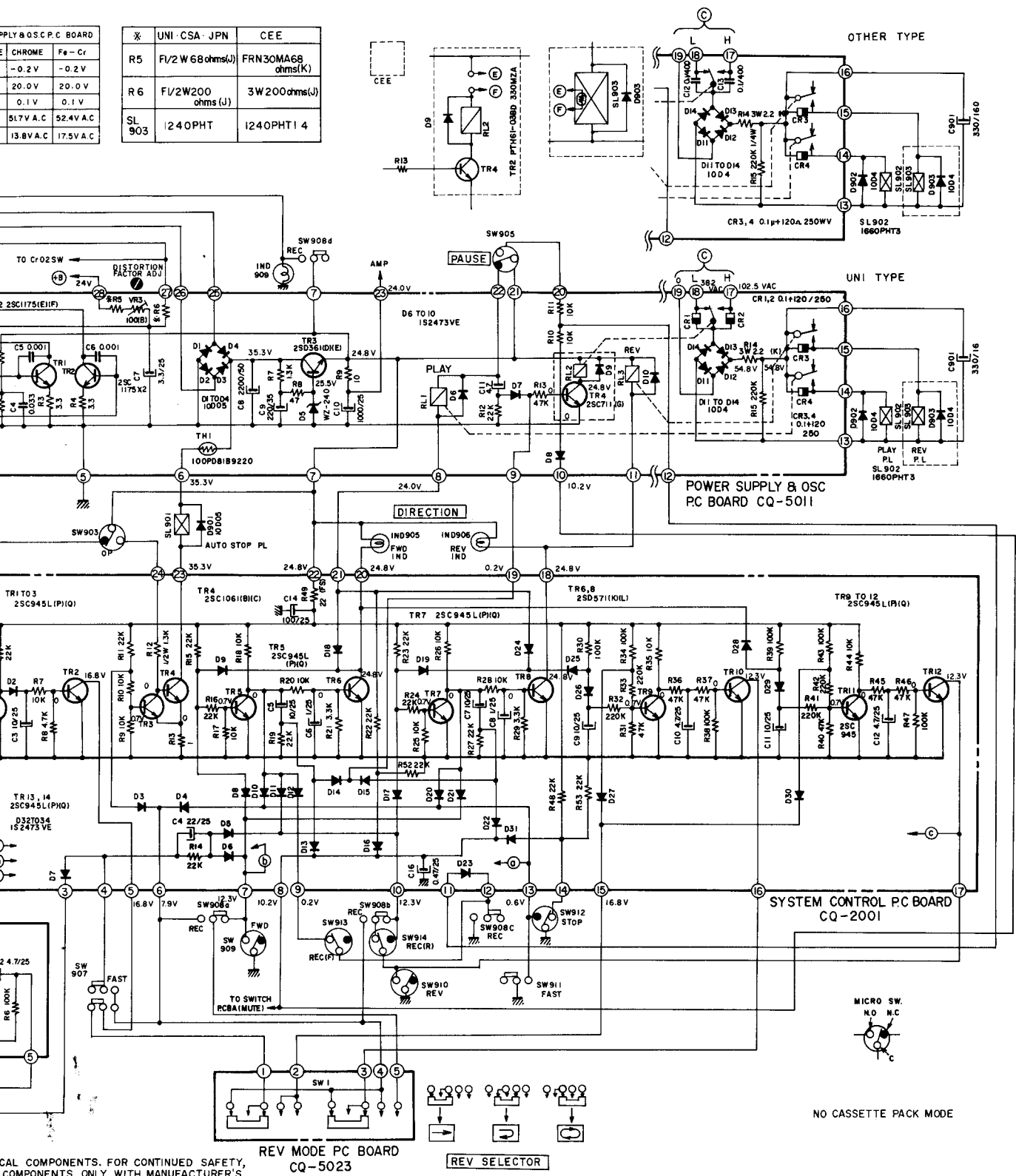

CAUTION: FOR CONTINUED SAFETY, REPLACEMENT COMPONENTS MUST BE IDENTICAL TO ORIGINALS. ONLY USE MANUFACTURER'S RECOMMENDED PARTS.

ATTENTION: POUR LA SÛRETÉ DE L'APPAREIL, NE REMPLACEZ LES COMPOSANTS QUE PAR DES ÉQUIVALENTS IDENTIQUES À L'ORIGINAL. SEULEMENT LES PIÈCES RECOMMANDÉES PAR LE FABRICANT.

NOTE
 1. UNLESS OTHERWISE SPECIFIED ALL RESISTORS IN OHMS (1/4W (J) ALL CAPACITORS IN µF 50V(V(J)) P = µ F
 2. POWER TRANSFORMER IS DIFFERENT ACCORDING TO AREA

GXC-730D AMP SCHEMATIC DIAGRAM

NO. 2-2 1541213A