

STR-1800

US Model
Canadian Model
AEP Model
UK Model



FM STEREO/FM-AM RECEIVER

SPECIFICATIONS

GENERAL

- System:** Superheterodyne fm/a-m tuner, Complementary symmetry power amplifier circuit (SEPP OTL)
- Power Requirements:** 120 Vac, 60 Hz (US, Canadian model)
220 Vac, 50/60 Hz (AEP model)
240 Vac, 50 Hz (UK model)
- Power Consumption:** 60W (US, Canadian model)
80W (AEP model)
90W (UK model)
- AC Outlet:** 1 unswitched, 250W (US, Canadian model)
- Dimensions:** Approx.
479 (w) x 153 (h) x 332 (d) mm
18 7/8 (w) x 6 (h) x 13 (d) inches
including projecting parts and controls
- Weight:** Approx. 7.5 kg, 16 lb 10 oz, net
Approx. 9.6 kg, 21 lb 2 oz, in shipping carton

AMPLIFIER SECTION

- Continuous RMS Power Output:** Both channels driven simultaneously at 40 – 20,000 Hz
(Less than 0.8% harmonic distortion)
- 12W + 12W (8 Ω)
at 1 kHz
13W + 13W (8 Ω)
According to DIN 45500 } (AEP, UK model)
12W + 12W (8 Ω)

SAFETY-RELATED COMPONENT WARNING!!

COMPONENTS IDENTIFIED BY SHADING ON THE SCHEMATIC DIAGRAMS AND IN THE PARTS LIST ARE CRITICAL TO SAFE OPERATION. REPLACE THESE COMPONENTS WITH SONY PARTS WHOSE PART NUMBERS APPEAR AS SHOWN IN THIS MANUAL OR IN SUPPLEMENTS PUBLISHED BY SONY.

Dynamic Power Output: 48W (8 Ω) (AEP, UK model)
(IHF constant power supply method)

Harmonic Distortion: Less than 0.8% at rated output

Inputs:

	sensitivity	impedance	S/N
PHONO	3mV	47 kΩ	60 dB
TAPE, REC/PB (input)	440mV	50 kΩ	70 dB

Outputs:

	sensitivity	impedance
REC OUT	250mV	10 kΩ
REC/PB (output)	30mV	80 kΩ

Headphones: Accepts headphones of 8 Ω or more.

Speaker: Accepts speakers of 8 Ω or more.

Frequency Response: PHONO RIAA curve ± 2 dB
TAPE, REC/PB (input) 40 – 20,000 Hz ± 1 dB

Tone Controls: BASS ± 10 dB at 100 Hz
TREBLE ± 10 dB at 10 kHz

Loudness Control: + 10 dB at 100 Hz
(att. 30 dB) + 4 dB at 10 kHz

– continued on page 2 –

SONY®

SERVICE MANUAL

STR-1800

FM SECTION

Tuning Range: 87.5 MHz – 108 MHz
Intermediate Frequency: 10.7 MHz
Antenna: 300Ω balanced
Usable Sensitivity: 3.5 μV (IHF)
2.2 μV S/N = 30 dB
Selectivity: 50 dB
Separation: Better than 30 dB
Frequency Response: 20 – 15,000 Hz ± 3 dB
Capture Ratio: 2 dB
Image Response Ratio: 30 dB
IF Response Ratio: 60 dB
AM Suppression Ratio: 40 dB
SCA Rejection Ratio: 60 dB (US, Canadian model)
Sub-carrier Product Ratio: 40 dB

AM SECTION

Tuning Range: 530 kHz – 1,605 kHz
Intermediate Frequency: 455 kHz (US, Canadian, AEP model)
468 kHz (UK model)
Antenna: Built-in ferrite-rod antenna
External antenna terminal
Sensitivity: 50 dB/m, built-in antenna
35 μV, external antenna
Selectivity: 30 dB
Signal-to-noise Ratio: 55 dB
Harmonic Distortion: 1% at 400 Hz
Image Response Ratio: 30 dB
IF Response Ratio: 20 dB

MODEL IDENTIFICATION

- Specification Label

US, Canadian model

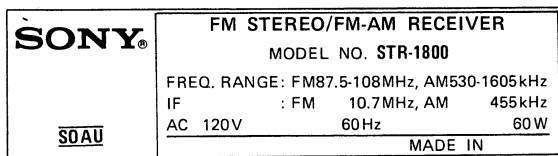

AEP model

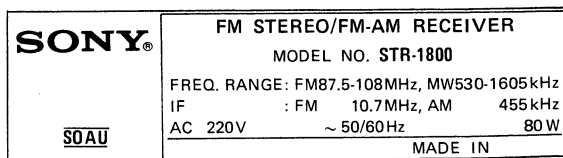

UK model

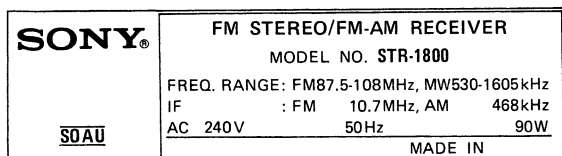

SECTION 1
BLOCK DIAGRAM

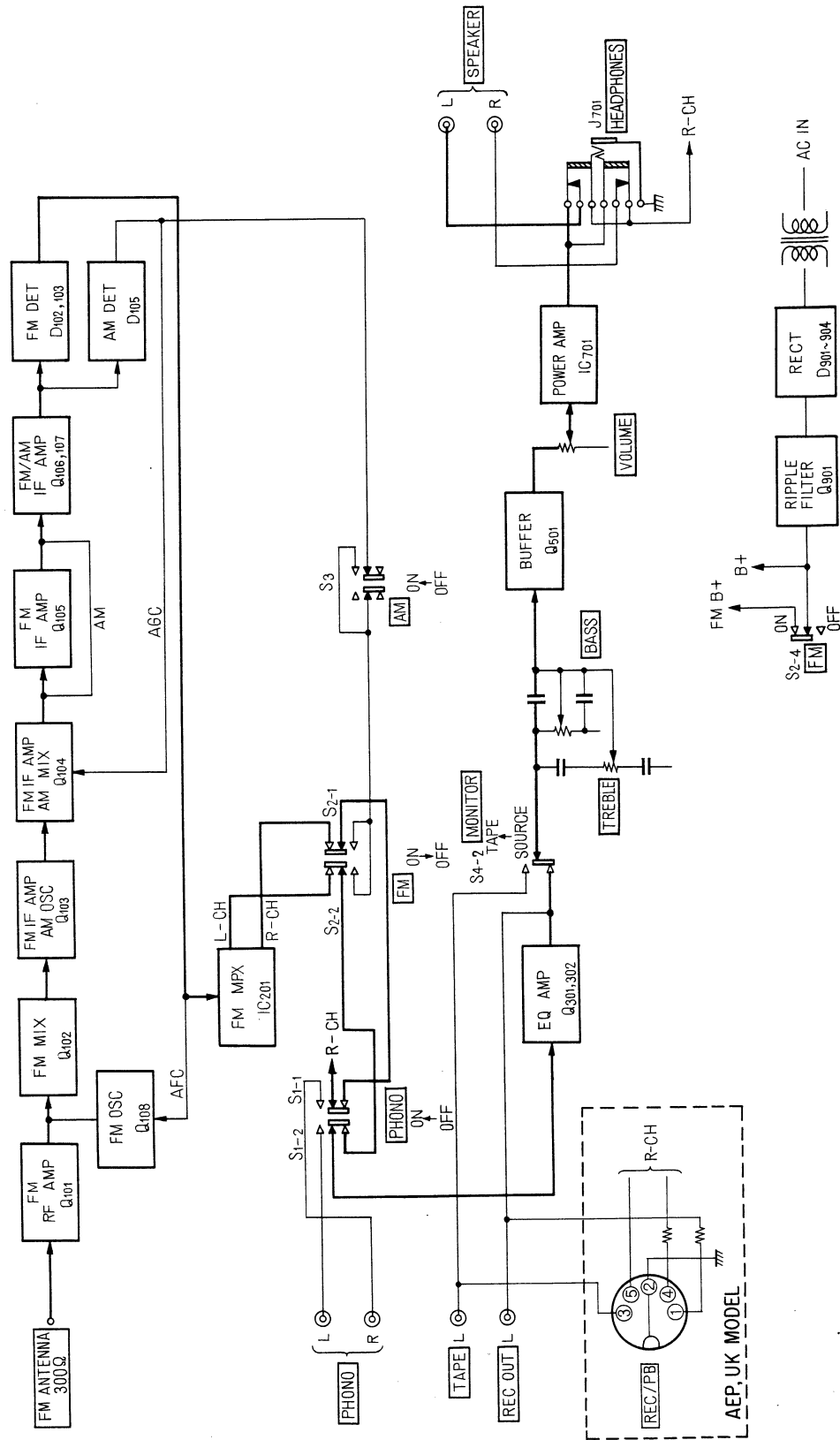

SECTION 2
DIAL CORD STRINGING

2-1. PREPARATION

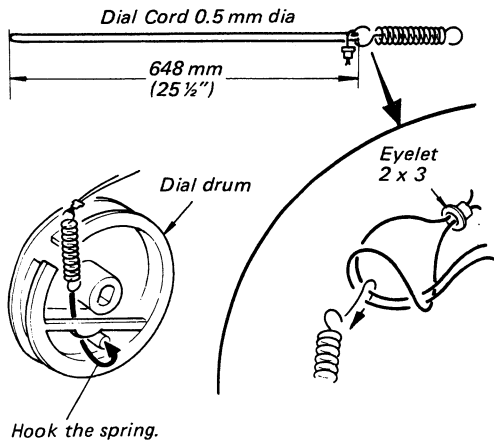

2-2. DIAL DRUM INSTALLATION

1. Turn the tuning capacitor shaft fully clockwise.
2. Install the dial drum as shown below.

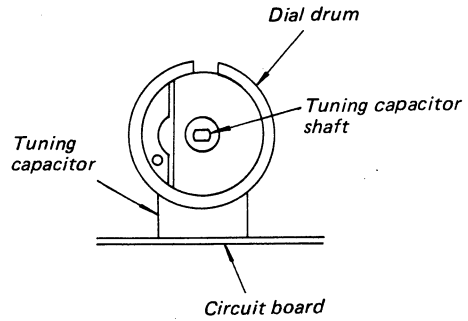

2-3. DIAL CORD STRINGING

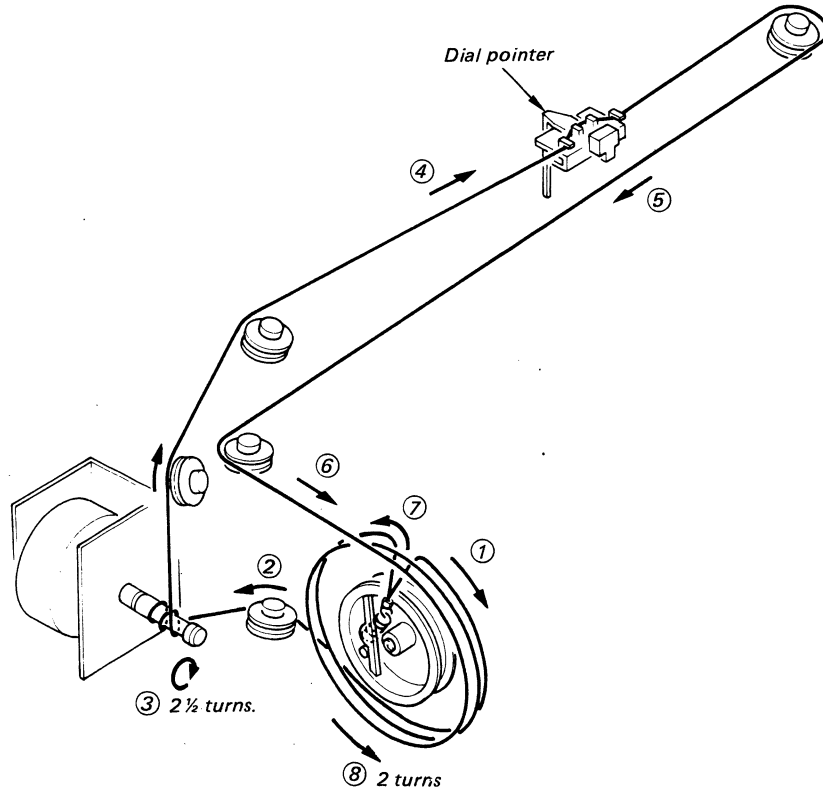

2-4. DIAL POINTER SETTING

1. Turn the tuning shaft and receive a broadcasting signal.
2. Set the dial pointer to the position which shows the broadcasting signal frequency.
3. Secure the dial pointer to the dial cord with locking compound.

SECTION 3
REMOVAL AND ADJUSTMENTS

3-1. BOTTOM PLATE REMOVAL
(for checking voltages on the circuit board)

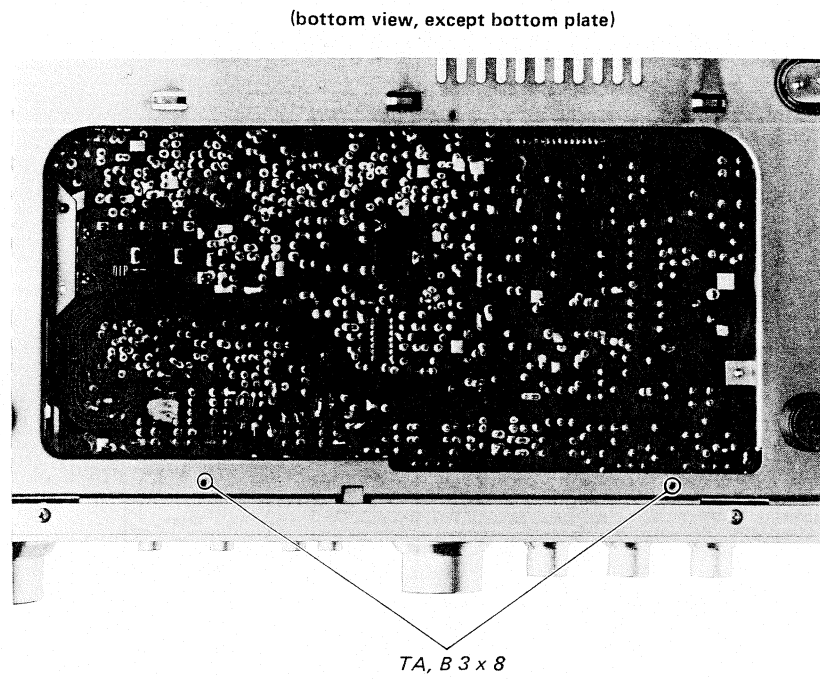

AM IF ALIGNMENT	
Adjust for a maximum reading on VOM.	
455 kHz (468 kHz)	CFU101

(): UK model

AM FREQUENCY COVERAGE ADJUSTMENT	
Adjust for a maximum reading on VOM.	
520 kHz	1,680 kHz
L103	CT102

AM TRACKING ADJUSTMENT	
Adjust for a maximum reading on VOM.	
L105	620 kHz
CT104	1,400 kHz

FM TRACKING ADJUSTMENT	
L101	87.2MHz (87.5MHz)
CT101	108.4MHz (108MHz)
Adjust for a maximum reading on VOM.	

(): in West Germany

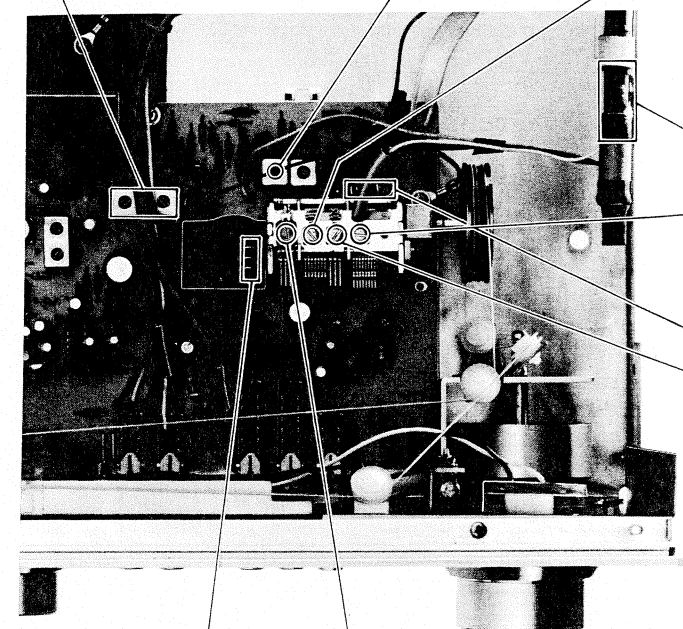

L104	CT103
87.2 MHz (87.5 MHz)	108.4 MHz (108 MHz)
Adjust for a maximum reading on VOM.	

FM FREQUENCY COVERAGE ADJUSTMENT
(): in West Germany

3-2. ADJUSTMENTS

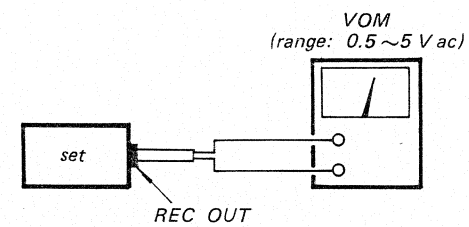
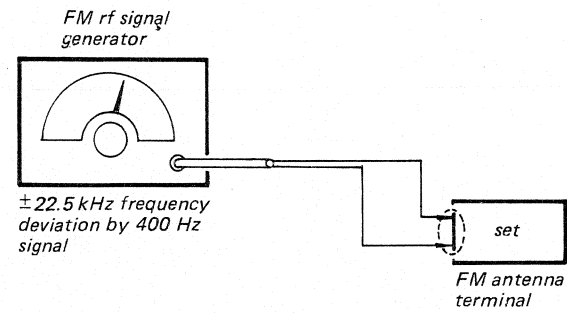
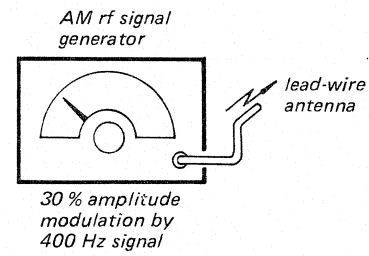

- Repeat the procedures in each adjustment several times, and the frequency coverage and tracking adjustments should be finally done by the trimmer capacitors.

MPX ADJUSTMENT

A) With Frequency Counter

Procedure:

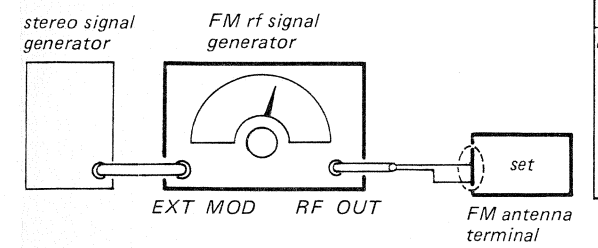

Carrier frequency: 98 MHz
Modulation: 400 Hz, 75 kHz deviation (100%)
Output level: 1 mV (60 dB)

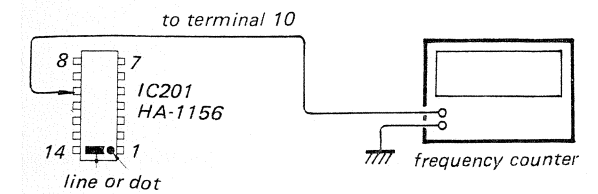

- Tune the set to 98 MHz.
- Adjust RV201 for 19 kHz ± 30 Hz on the counter.

AM IF ALIGNMENT	
Adjust for a maximum reading on VOM.	
455 kHz (468 kHz)	
CFU101	

AM FREQUENCY COVERAGE ADJUSTMENT	
Adjust for a maximum reading on VOM.	
520 kHz	1,680 kHz
L103	CT102

AM TRACKING ADJUSTMENT	
Adjust for a maximum reading on VOM.	
L105	620 kHz
CT104	1,400 kHz

FM TRACKING ADJUSTMENT	
L101	87.2MHz (87.5MHz)
CT101	108.4MHz (108MHz)
Adjust for a maximum reading on VOM.	

L104	CT103
87.2 MHz (87.5 MHz)	108.4 MHz (108 MHz)
Adjust for a maximum reading on VOM.	
FM FREQUENCY COVERAGE ADJUSTMENT	

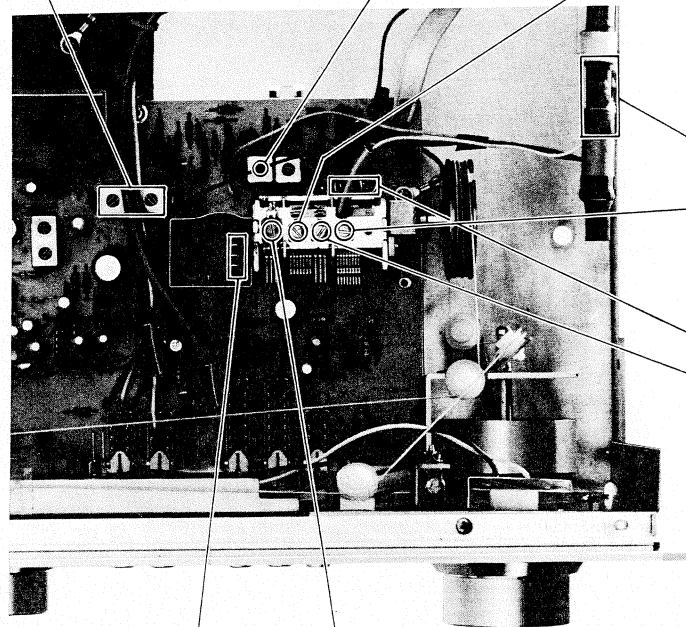

() : UK model

() : in West Germany

FM IF ALIGNMENT 1

Procedure:

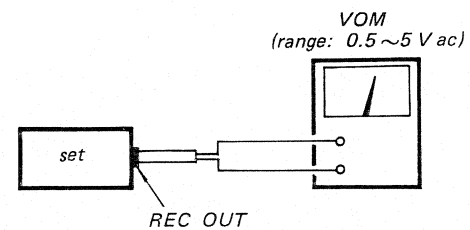
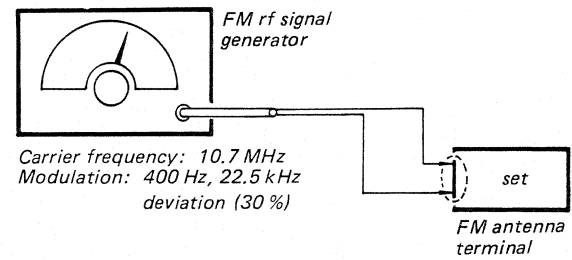

Adjust for a maximum reading on VOM.

IFT103 primary IFT101

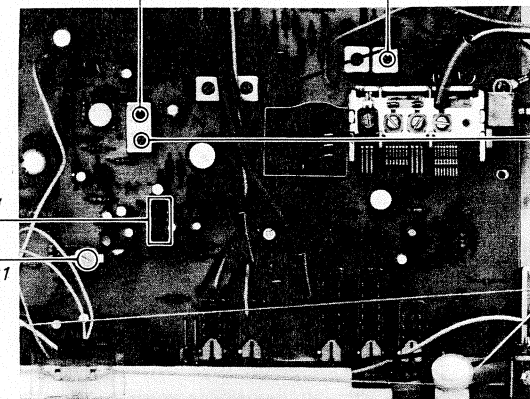

IFT103 secondary

FM IF ALIGNMENT 2 (DISCRIMINATOR ALIGNMENT)

A) With Oscilloscope

Procedure:

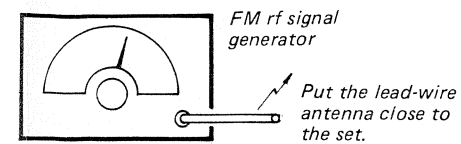

Carrier frequency: 10.7 MHz
Modulation: 400 Hz, 30%

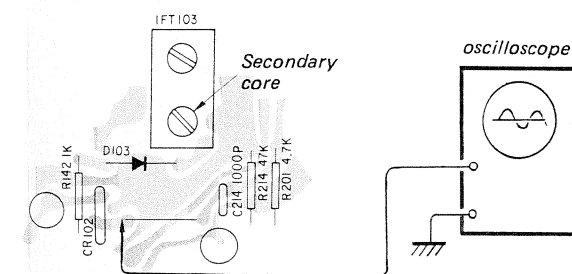

Adjust secondary core of IFT103.

Oscilloscope Pattern

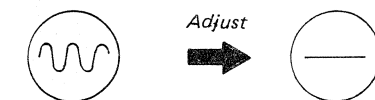

B) With VOM

Procedure:

1. Detune the set.
2. Adjust secondary core of IFT103 for 0 V dc reading on VOM.

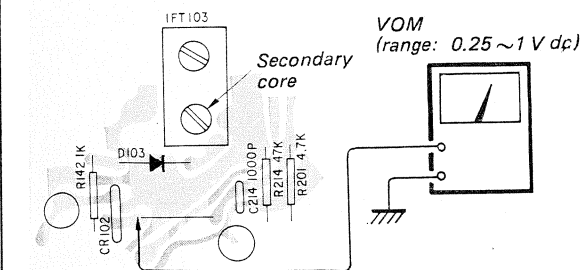

MPX ADJUSTMENT

A) With Frequency Counter

Procedure:

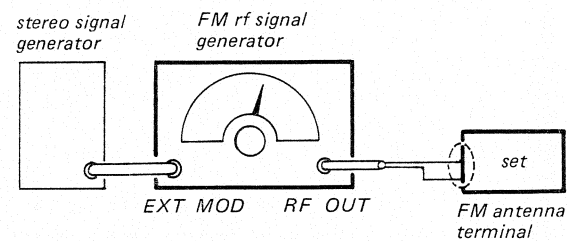

Carrier frequency: 98 MHz
Modulation: 400 Hz, 75 kHz deviation (100%)
Output level: 1 mV (60 dB)

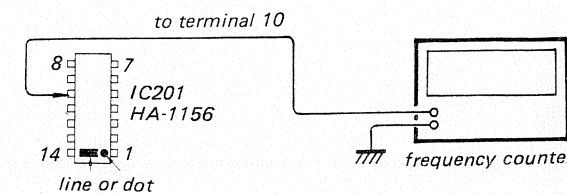

1. Tune the set to 98 MHz.
2. Adjust RV201 for 19 kHz ± 30 Hz on the counter.

B) Without Frequency Counter

Procedure:

1. Tune the set to the FM stereo broadcasting signal.
2. Turn RV201 clockwise or counterclockwise and memorize the lighting-up range of stereo lamp.
3. Secure RV201 at the center in lighting-up range of both turns as shown below.

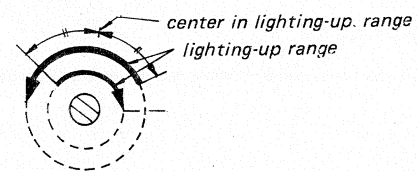

SECTION 4
DIAGRAMS

4-1. MOUNTING DIAGRAM
— Conductor Side —

Q101, 102, 104 ~ 108
Q110, D108: 2SC710

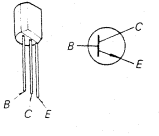

D201: EQA01-15R

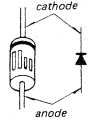

Q103: 2SC403C
Q301, 401: 2SC631A
Q302, 402: 2SC634A
Q501, 601: 2SC632A

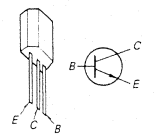

Q901: 2SC1475

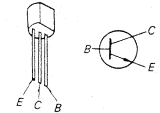

IC201: HA1156

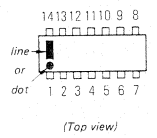

IC701: STK439

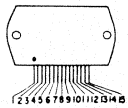

D101 : 1S1555
D102, 103 : 1T22A
D105 ~ 107 : 1T22A
D901 ~ 904: 10E2

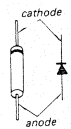

Note:

- : fusible resistor
- : non-flammable resistor
- : indicates designation on the panel.
- : B+ pattern
- : FM RF/IF signal path
- : L-CH FM AF signal path
- : R-CH FM AF signal path

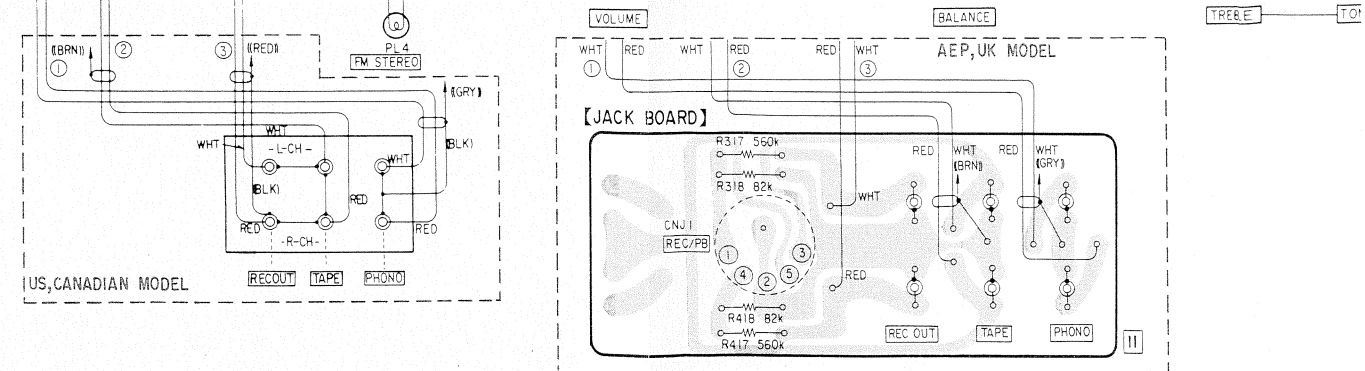
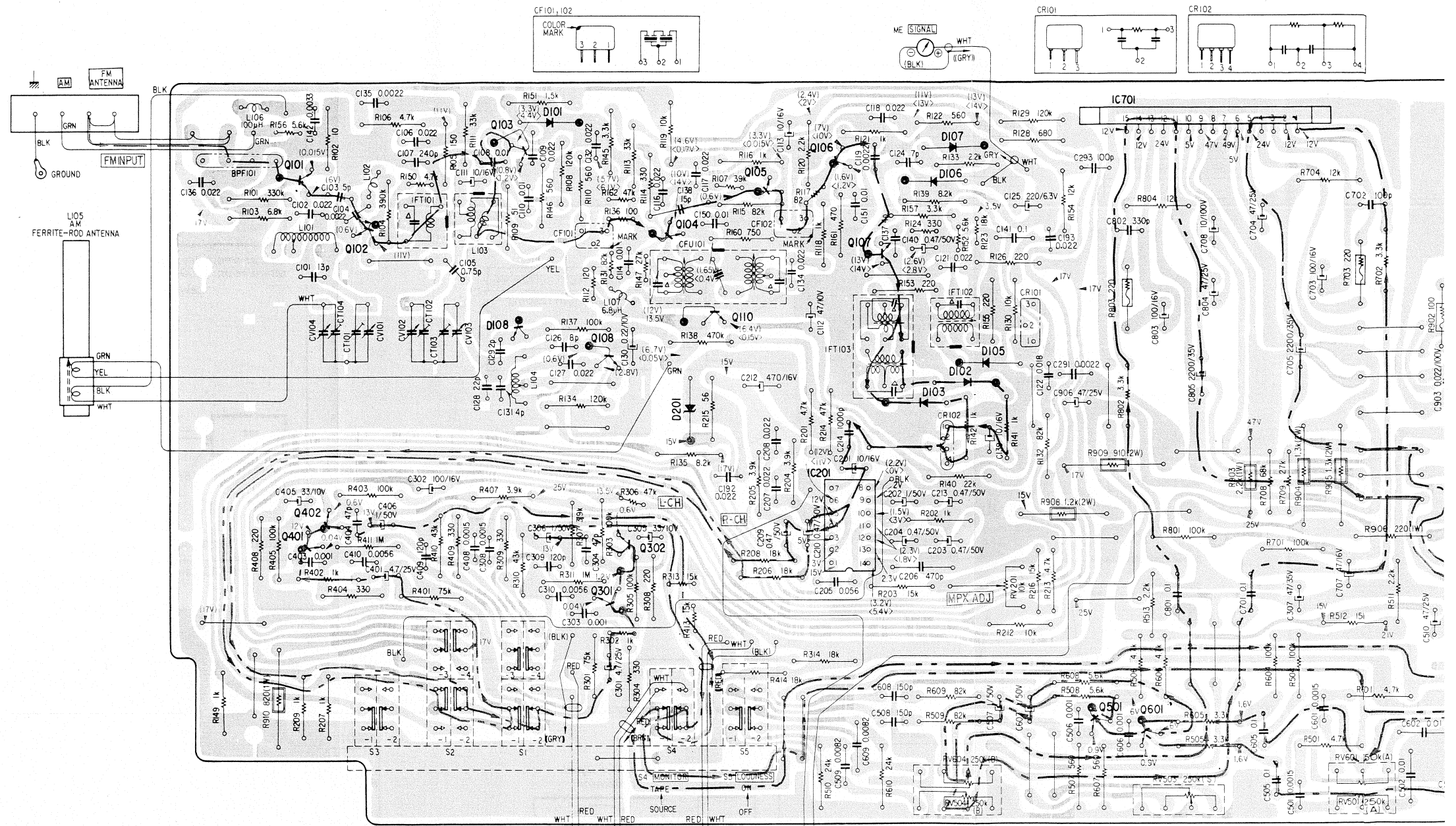
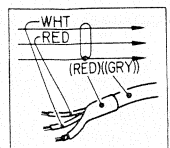

Q	101	102	103	104	105	106	107	IC701			
IC	401	402		108	301	302	IC201	501	601		
D			108	101	201		106	107	103	102	105

STR-1800 STR-1800

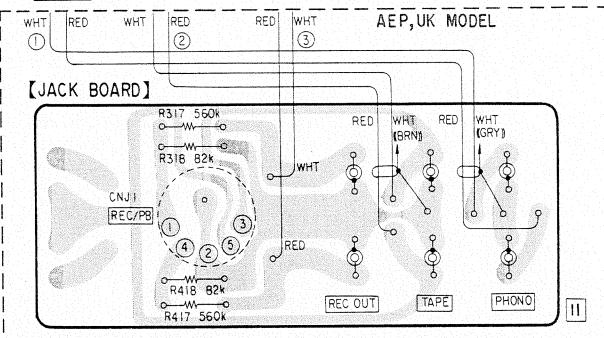
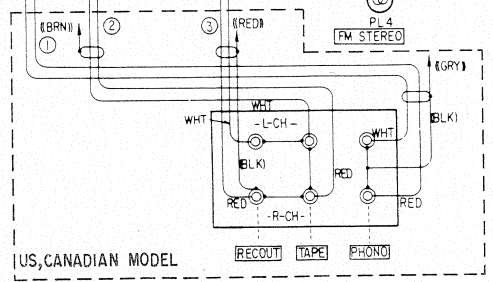
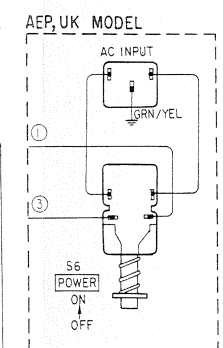
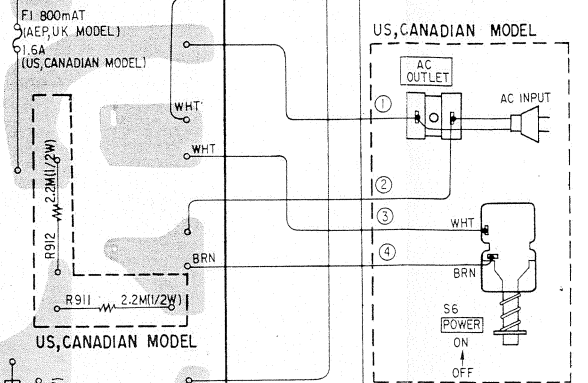
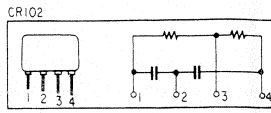
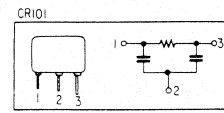
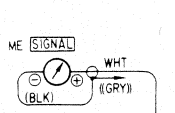
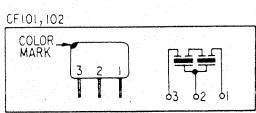
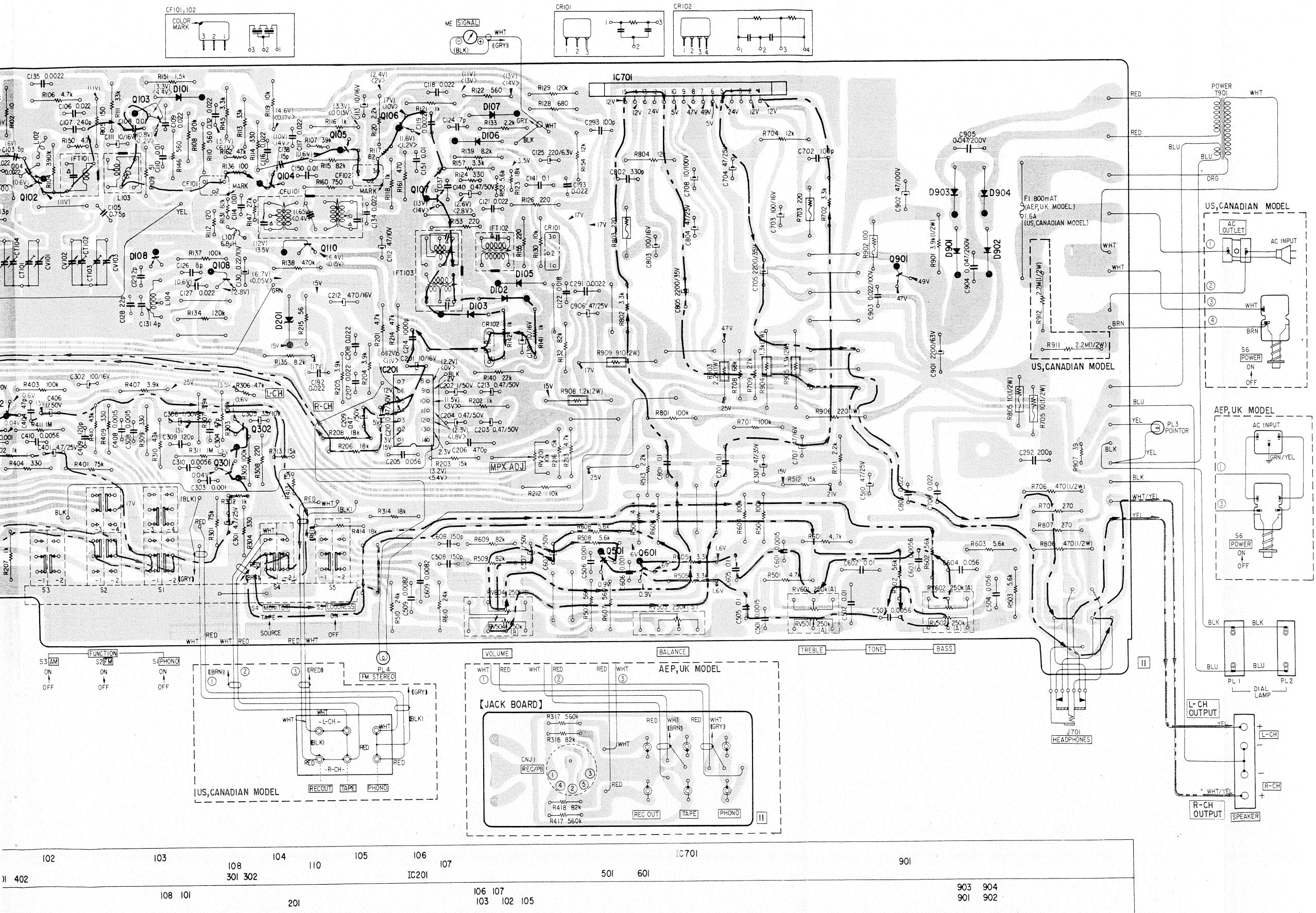

102	103	108	104	110	105	106	107	IC701	901
102	108 101	301 302	201	106 107	103 102 105			501 601	903 904 901 902

STR-1800 STR-1800

Note: The components identified by shading are critical for safety. Replace only with part number specified.

4-2. SCHEMATIC DIAGRAM

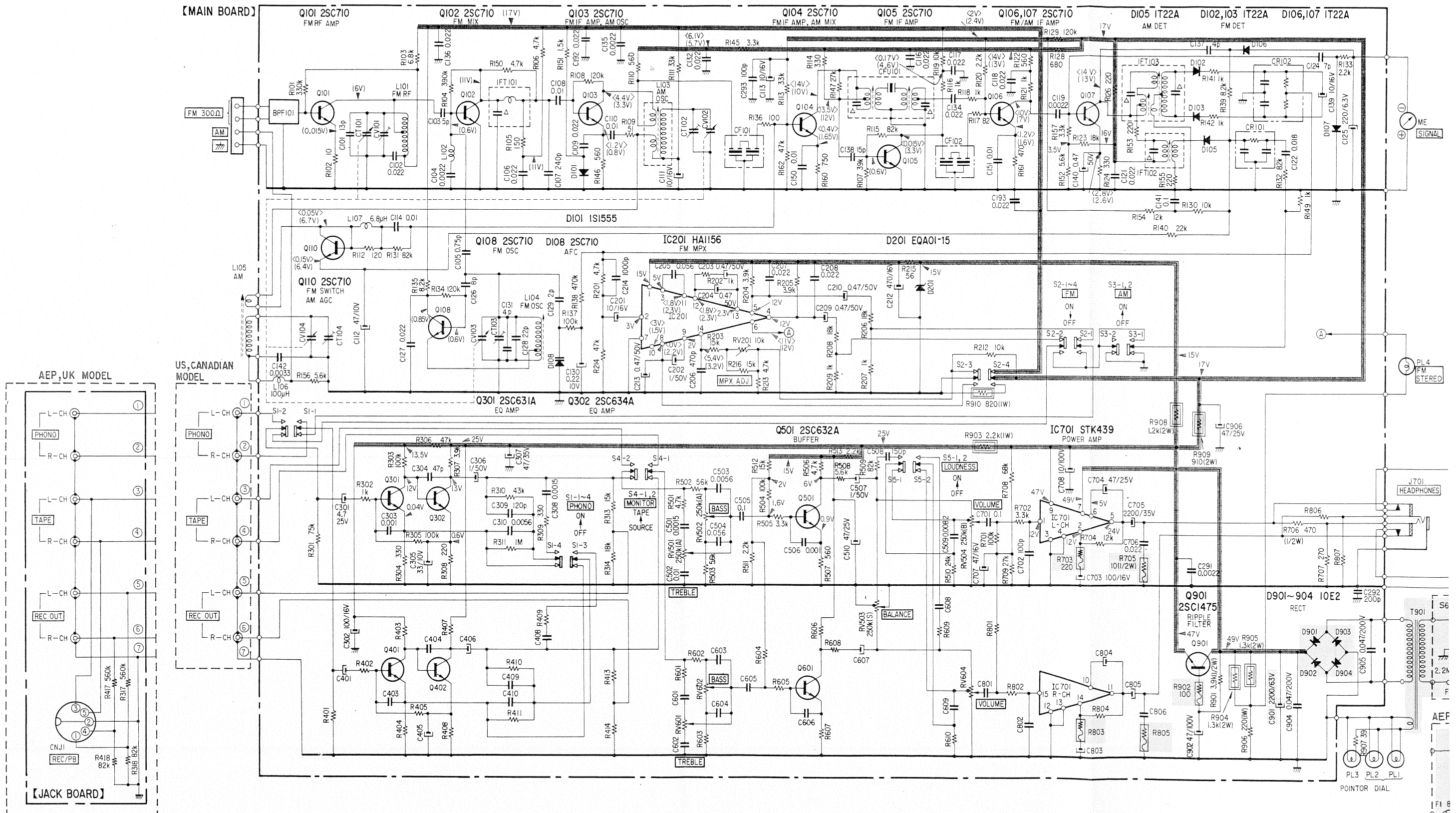

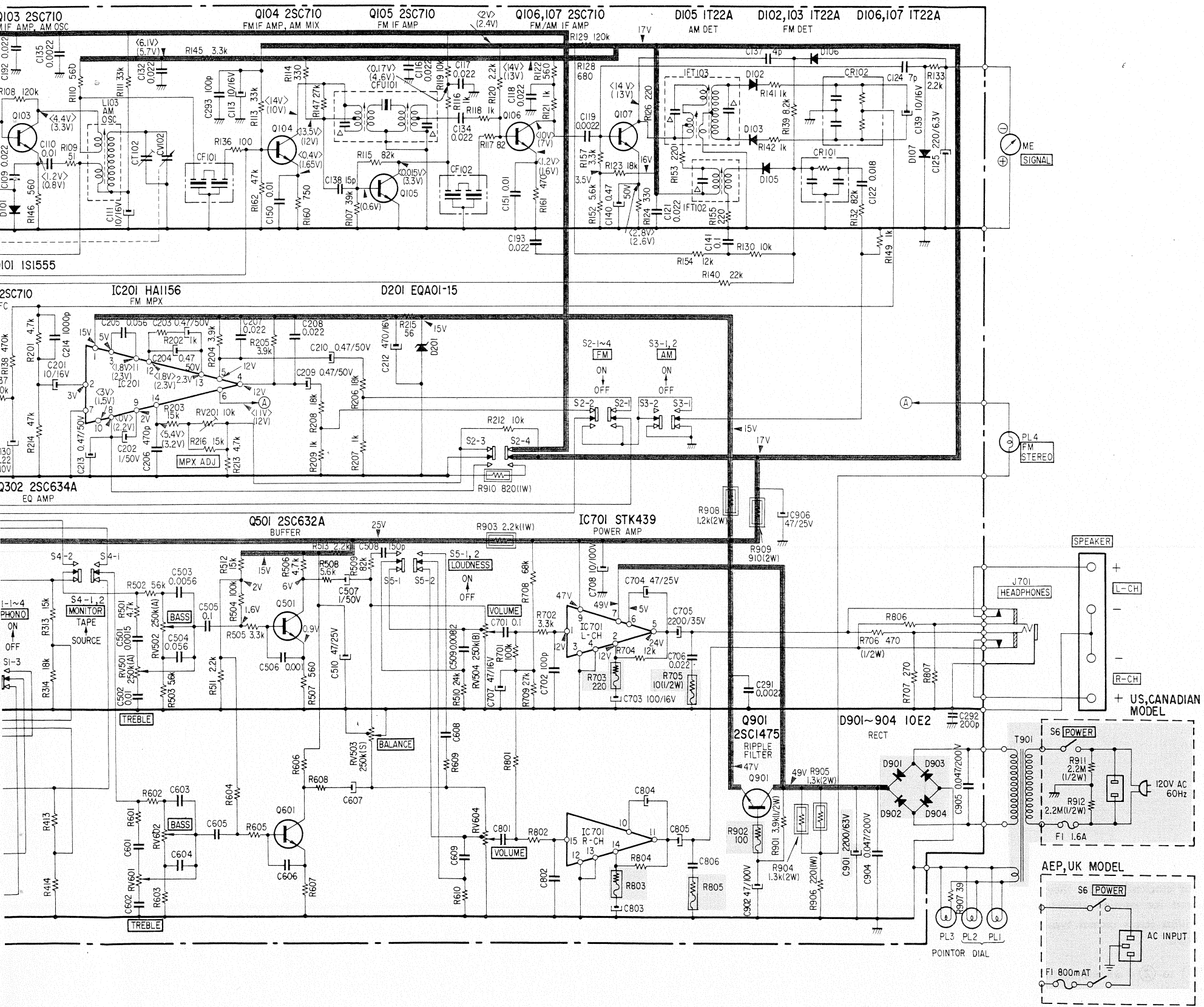

Note:

- All capacitors are in μF unless otherwise noted. 50 or less working volts are omitted except for electrolytic type. $p = \mu\text{F}$.
- All resistors are in Ω , $\frac{1}{4}W$, unless otherwise noted. $k = 1,000$ $M = 1000k$
- \triangle : indicates internal components.
- --- : indicates chassis ground.
- --- : indicates B+ bus.
- Transistor is used for D108 instead of diode.
- Voltages are dc with respect to ground unless otherwise noted.
- Readings are taken with a 20,000 ohm-per-volt VOM. () : FM < > : AM no mark : common
- Voltage variations may be noted due to normal production tolerances.
- --- : fusible resistor
- --- : non-flammable resistor
- --- : indicates designation on the panel.
- Switch Mode:

Ref. No.	Switch	Position
S1-1 ~ 4	PHONO	OFF
S2-1 ~ 4	FM	ON
S3-1, 2	AM	OFF
S4-1, 2	MONITOR SOURCE	SOURCE
S5-1, 2	LOUDNESS	OFF
S6	POWER	OFF

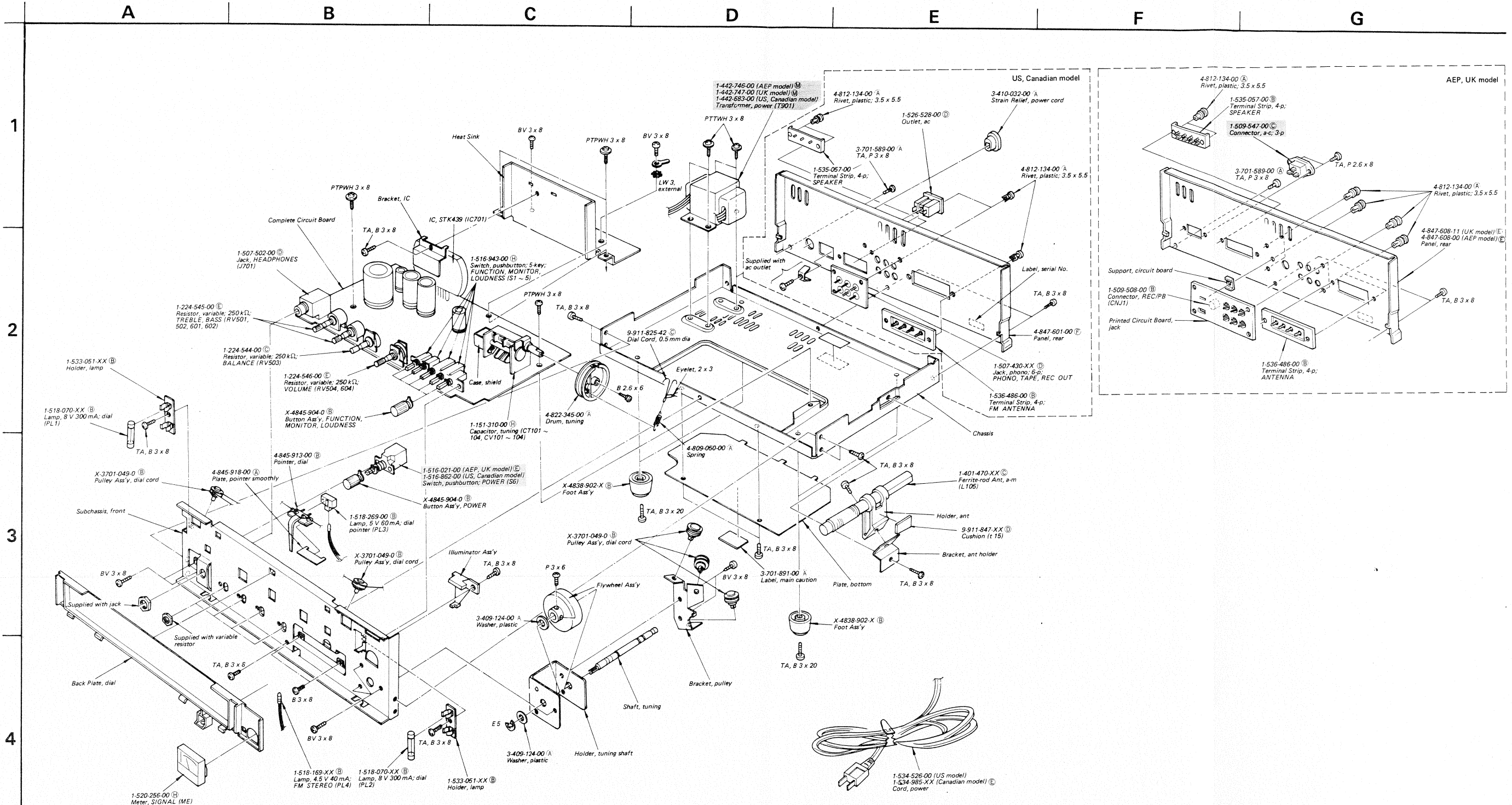

Note: The components identified by shading are critical for safety. Replace only with part number specified.

Note:

- Items with no part number and/or no description are not stocked because they are seldom required for routine service.
- All screws are Phillips (cross recess) type unless otherwise noted. (—) = slotted head
- Circled letters (A) to (Z) are applicable to European models only.

SECTION 6
ELECTRICAL PARTS LIST

Note: Circled letters (A to Z) are applicable to European models only.

Ref. No.	Part No.	Description
SEMICONDUCTORS		
Transistors		
Q101	(B) 2SC710	
Q102	(B) 2SC710	
Q103	(B) 2SC403C	
Q104 ~ 108, Q110	(B) 2SC710	
Q301, 401	(B) 2SC631A	
Q302, 402	(B) 2SC634A	
Q501, 601	(B) 2SC632A	
Q901	(C) 2SC1475	
Diodes		
D101	(B) 1S1555	
D102, 103	(B) 1T22A	
D105 ~ 107	(B) 1T22A	
D108	(B) 2SC710	
D201	(B) EQA01-15R	
D901 ~ 904	(B) 10E2	
ICs		
IC201	(J) HA1156	
IC701	(L) STK439	
COILS		
L103	1-405-597-00 (B) AM Osc	
L105	1-401-470-XX (C) AM Ferrite-rod Antenna	
L106	1-407-169-XX (A) Microinductor, 100 μH	
L107	1-407-188-XX (A) Microinductor, 6.8 μH	
TRANSFORMERS		
CFU101	(1-403-830-51 (C) AM IFT (UK model) 1-403-150-00 (C) AM IFT (US, Canadian, AEP model)	
IFT101	1-404-004-00 (B) FM IFT	
IFT102	1-403-900-00 (B) AM IFT	
IFT103	1-403-822-21 (C) FM Discriminator	
T901	(1-442-683-00 Power (US, Canadian model) 1-442-746-00 (M) Power (AEP model) 1-442-747-00 (M) Power (UK model)	

Ref. No.	Part No.	Description
FILTERS		
CF101, 102	1-527-220-91 (B) Ceramic, 10.7 MHz	
BPF101	1-231-307-00 (B) Band-pass	
CAPACITORS		
All capacitors are in μF and ceramic unless otherwise noted. 50WV or less are not indicated except for electrolytics. pF = μμF, elect = electrolytic		
C101	1-102-950-11 (A) 13 p	
C102	1-101-005-11 (A) 0.022	
C103	1-102-807-11 (A) 5 p	
C104	1-102-121-11 (A) 0.0022	
C105	1-101-586-11 (A) 0.75 p	
C106	1-101-005-11 (A) 0.022	
C107	1-102-979-11 (A) 240 p	
C108	1-101-004-11 (A) 0.01	
C109	1-101-005-11 (A) 0.022	
C110	1-108-837-12 (A) 0.01	mylar
C111	1-121-651-11 (A) 10	16 V elect
C112	1-123-195-11 (A) 47	10 V elect
C113	1-121-651-11 (A) 10	16 V elect
C114	1-101-004-11 (A) 0.01	
C116 ~ 118	1-101-005-11 (A) 0.022	
C119	1-102-121-11 (A) 0.0022	
C121	1-101-005-11 (A) 0.022	
C122	1-108-840-12 (A) 0.018	mylar
C124	1-102-809-11 (A) 7 p	
C125	1-121-419-51 (A) 220	6.3 V elect
C126	1-102-684-11 (A) 8 p	
C127	1-101-005-11 (A) 0.022	
C128	1-102-805-11 (A) 22 p	
C129	1-102-681-11 (A) 2 p	
C130	1-127-046-11 (A) 0.22	16 V solid aluminum
C131	1-102-683-11 (A) 4 p	
C132, 134	1-101-005-11 (A) 0.022	
C135	1-102-121-11 (A) 0.0022	
C136	1-101-005-11 (A) 0.022	
C137	1-102-937-11 (A) 4 p	

Ref. No.	Part No.	Description
C138	1-102-951-11 (A) 15 p	
C139	1-121-651-11 (A) 10	16 V elect
C140	1-121-726-11 (A) 0.47	50 V elect
C141	1-101-797-11 (A) 0.1	(boundary layer)
C142	1-108-798-12 (A) 0.0033	mylar
C150, 151	1-101-004-11 (A) 0.01	
C192, 193	1-101-005-11 (A) 0.022	
C201	1-121-651-11 (A) 10	16 V elect
C202	1-121-391-11 (A) 1	50 V elect
C203, 204	1-121-726-11 (A) 0.47	50 V elect
C205	1-108-846-12 (A) 0.056	mylar
C206	1-103-817-11 (A) 470 p	polystyrol
C207, 208	1-108-242-12 (A) 0.022	mylar
C209, 210	1-121-726-11 (A) 0.47	50 V elect
C212	1-121-426-11 (B) 470	16 V elect
C213	1-121-726-11 (A) 0.47	50 V elect
C214	1-102-074-11 (A) 0.001	
C291	1-108-230-12 (A) 0.0022	mylar
C292	1-102-977-11 (A) 200 p	
C293	1-102-973-11 (A) 100 p	
C301, 401	1-121-395-11 (A) 4.7	25 V elect
C302	1-121-415-11 (A) 100	16 V elect
C303, 403	1-101-001-11 (A) 0.001	
C304, 404	1-101-881-11 (A) 47 p	
C305, 405	1-121-402-11 (A) 33	10 V elect
C306, 406	1-121-391-11 (A) 1	50 V elect
C307	1-123-186-11 (B) 47	35 V elect
C308, 408	1-102-119-11 (A) 0.0015	
C309, 409	1-101-340-11 (A) 120 p	
C310, 410	1-108-801-12 (A) 0.0056	mylar
C501, 601	1-102-119-11 (A) 0.0015	
C502, 602	1-102-129-11 (A) 0.01	
C503, 603	1-102-126-11 (A) 0.0056	
C504, 604	1-108-849-12 (B) 0.056	mylar
C505, 605	1-101-797-11 (A) 0.1	(boundary layer)
C506, 606	1-101-001-11 (A) 0.001	
C507, 607	1-121-391-11 (A) 1	50 V elect
C508, 608	1-102-108-11 (A) 150 p	

Note: Circled letters (A to Z) are applicable to European models only.

Ref. No.	Part No.	Description
C509, 609	1-102-128-11 (A) 0.0082	
C510	1-123-190-11 (B) 47	25 V elect
C701, 801	1-108-829-12 (B) 0.1	mylar
C702, 802	1-102-106-11 (A) 100 p	
C703, 803	1-123-193-11 (B) 100	16 V elect
C704, 804	1-123-190-11 (B) 47	25 V elect
C705, 805	1-121-984-11 (D) 2200	35 V elect
C706, 806	1-101-005-11 (A) 0.022	
C707	1-123-192-11 (A) 47	16 V elect
C708	1-123-080-11 (B) 10	100 V elect
C901	1-125-137-11 (E) 2200	63 V elect
C902	1-123-083-11 (B) 47	100 V elect
C904, 905	1-108-725-12 (B) 0.047	200 V mylar
C906	1-123-190-11 (B) 47	25 V elect
CT101 ~ 104, CV101 ~ 104	1-151-310-00 (H) tuning	

RESISTORS

All resistors are in ohms. Common ¼W carbon resistors are omitted. Check schematic diagram for values.
(k = 1000, M = 1000 k)

R703, 803	1-212-891-11 (A) 270	¼ W fusible (nonflammable)
R705, 805	1-212-958-11 (A) 10	½ W fusible (nonflammable)
R706, 806	1-202-565-11 (A) 470	½ W composition
R901	1-202-587-11 (A) 3.9 k	½ W composition
R902	1-212-881-11 (A) 100	¼ W fusible
R903	1-213-147-11 (A) 2.2 k	1 W metal-oxide (nonflammable)
R904, 905	1-206-667-11 (A) 1.3 k	2 W metal-oxide (nonflammable)
R906	1-213-135-11 (A) 220	1 W metal-oxide (nonflammable)
R908	1-206-666-11 (A) 1.2 k	2 W metal-oxide (nonflammable)
R909	1-206-663-11 (A) 910	2 W metal-oxide (nonflammable)
R910	1-213-142-11 (A) 820	1 W metal-oxide (nonflammable)

Note: The components identified by shading are critical for safety. Replace only with part number specified.

Note: The components identified by shading are critical for safety. Replace only with part number specified.

Note: Circled letters (A) to (Z) are applicable to European models only.

Ref. No.	Part No.	Description
R911, 912	1-202-723-11	2.2 M 1/2 W composition (US, Canadian model)
RV201	1-222-787-00 (B)	10 k, adjustable; MPX
RV501, 601	1-224-545-00 (E)	250 k, variable; TREBLE, BASS
RV502, 602		
RV503	1-224-544-00 (C)	250 k, variable; BALANCE
RV504, 604	1-224-546-00 (E)	250 k, variable; VOLUME

SWITCHES

S1 ~ 5	1-516-943-00 (H)	Pushbutton, 5-key; FUNCTION, MONITOR, LOUDNESS
S6	1-516-862-00	Pushbutton, POWER (US, Canadian model)
	1-552-021-00 (E)	Pushbutton, POWER (AEP, UK model)

LAMPS

PL1, 2	1-518-070-XX (B)	8 V 300mA, dial
PL3	1-518-269-00 (B)	5 V 60 mA, dial pointer
PL4	1-518-169-XX (B)	4.5 V 40 mA, FM STEREO

Ref. No.	Part No.	Description
MISCELLANEOUS		
CNJ1	1-509-508-00 (B)	REC/PB Connector (AEP, UK model)
CR101	1-231-204-00 (B)	Encapsulated Component
CR102	1-231-202-00 (B)	Encapsulated Component
F1	1-532-267-00 (B)	Fuse, 1.6 A (US, Canadian model)
	1-532-215-00 (B)	Fuse, 800 mA (AEP, UK model)
J701	1-507-502-00 (D)	Jack, HEADPHONES
ME	1-520-256-00 (H)	Meter, SIGNAL
	1-507-430-XX (D)	Jack, phono; 6-p; PHONO, TAPE, REC OUT
	1-509-547-00 (C)	Connector, a-c; 3-p (AEP, UK model)
	1-526-528-00 (D)	Outlet, ac (US, Canadian model)
	1-533-051-XX (B)	Holder, lamp
	1-534-526-00	Cord, power (US model)
	1-534-985-XX	Cord, power (Canadian model)
	1-535-057-00 (B)	Terminal Strip, 4-p; SPEAKER
	1-536-486-00 (B)	Terminal Strip, 4-p; ANTENNA

ACCESSORIES AND PACKING MATERIALS

Part No.	Description
1-501-161-00	(F) Ribbon Antenna, fm
3-770-029-11	(E) Manual, instruction (AEP, UK model)
3-770-029-21	Manual, instruction (US, Canadian model)
3-794-013-31	Manual, instruction; French (Canadian model)
4-828-909-00	(E) Bag, plastic
4-847-606-00	(G) Carton
4-847-607-00	(D) Cushion

Note: The components identified by shading are critical for safety. Replace only with part number specified.

HARDWARE NOMENCLATURE

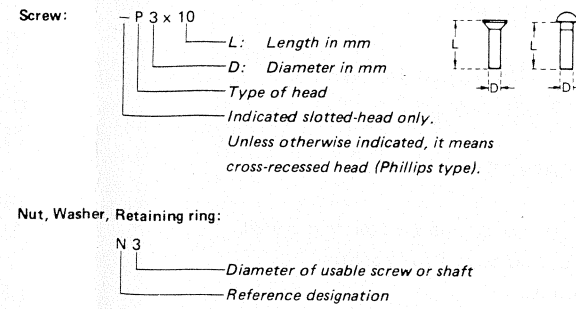

Reference Designation	Shape	Description	Remarks
SCREWS			
P		pan-head screw	binding-head (B) screw for replacement
PWH		pan-head screw with washer face	binding-head (B) screw and flat washer for replacement
PS PSP		pan-head screw with spring washer	binding-head (B) screw and spring washer for replacement
PSW PSPW		pan-head screw with spring and flat washers	binding-head (B) screw and spring and flat washers for replacement
R		round-head screw	binding-head (B) screw for replacement
K		flat-countersunk-head screw	
RK		oval-countersunk-head screw	
B		binding-head screw	
T		truss-head screw	binding-head (B) screw for replacement
F		flat-fillister-head screw	
RF		fillister-head screw	
BV		braizer-head screw	

Reference Designation	Shape	Description	Remarks
SELF-TAPPING SCREWS			
TA		self-tapping screw	ex: TA, P 3 x 10
PTP		pan-head self-tapping screw	binding-head self-tapping (TA, B) screw for replacement
PTPWH		pan-head self-tapping screw with washer face	binding-head self-tapping (TA, B) screw and flat washer for replacement
PTTWH		pan-head thread-rolling screw with washer face	binding-head (B) screw and flat washer for replacement
SET SCREWS			
SC		set screw	
SC		hexagon-socket set screw	ex: SC 2.6 x 4, hexagon socket
NUT			
N		nut	
WASHERS			
W		flat washer	
SW		spring washer	
LW		internal-tooth lock washer	ex: LW3, internal
LW		external-tooth lock washer	ex: LW3, external
RETAINING RINGS			
E		retaining ring	
G		grip-type retaining ring	