

## GENERAL DESCRIPTION

World-wide radio reception is yours with the Hallicrafters Model S-38C. This 5 tube communications receiver tunes from 540 kilocycles to 32 megacycles to bring you standard broadcast programs, foreign and domestic shortwave broadcasts, amateurs, police, ships, aircraft and countless other exciting distant stations. It receives both voice and code broadcasts and is designed to operate from 105 to 125 volt direct current (DC) or 60 cycles alternating current (AC). A 5-inch Alnico V permanent magnet speaker is built into the top of the cabinet and tip jacks have been provided on the back of the set for plugging in a pair of headphones. The RECEIVE-STANDBY switch on the front panel is a special feature which permits you to silence the receiver without turning the set off.



Hallicrafters Model S-38C

Good reception of both standard and shortwave broadcasts can be obtained in most localities with the 15 foot antenna wire included with your receiver. It is merely necessary to uncoil this wire, connect one end of it to terminal A1 on the back of the set and then run it about the room in any convenient manner. To complete the antenna installation, connect the jumper between terminals A2 and G.

Your set is provided with two tuning knobs for greater ease of tuning. Wide tuning is done with the knob marked TUNING and fine tuning with the knob marked BAND SPREAD. The BAND SPREAD knob permits you to accurately tune in stations on crowded bands by spreading them out so that they may be more easily separated. In this way you are able to hear many more stations than you would on an ordinary radio with just one tuning knob.

The amateur bands and principal shortwave channels of the world are clearly marked on the dial for your convenience. Since shortwave conditions vary with the season of the year and even with the time of day, shortwave programs may not be heard with the same regularity as standard broadcasts. A special table has been provided on page 3 to aid you in determining the most favorable times for shortwave listening.

## INSTALLATION INSTRUCTIONS

**ANTENNA** - The terminals marked A1, A2 and G on the back of the set are for antenna and ground connections. Good results can be obtained in most localities with the 15 foot antenna wire included with your receiver. This wire should be uncoiled to provide maximum signal pickup. An outside antenna 50 to 100 feet long (ordinary copper wire) may be necessary if the receiver is operated in a difficult reception area or steel constructed building. Connect the antenna wire to terminal A1 on the back of the set and then connect the jumper between terminals A2 and G. In some locations, reception may be improved by connecting a lead from terminal G to a cold water pipe or outside ground rod.

For really top performance, there is no substitute for an outside antenna such as used by the commercial radio stations. Provision has been made on your receiver for the connection of this type of antenna, commonly called a doublet. When a doublet antenna is used, the jumper is removed and the antenna is connected to terminals A1 and A2. Consult your radio dealer for further information.

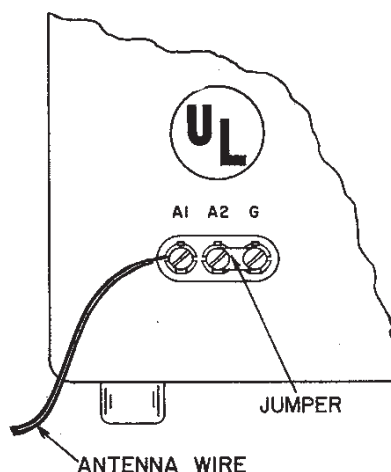

Fig. 1. Rear View of Receiver Showing Antenna and Ground Terminals

## OPERATING INSTRUCTIONS

**TUNING DIAL** - All dial readings are in megacycles. To convert the readings on the standard broadcast band (band 1) to kilocycles, simply remove the dot and add two zeros; thus, .7 on the dial corresponds to 700 kilocycles.

**AM-CW SWITCH** - Set this switch at AM to listen to voice and musical broadcasts. Set it at CW only if you wish to hear code signals.

**SPEAKER-PHONES SWITCH** - For operation of the built-in speaker, set the switch at SPEAKER. Tip jacks are provided on the back of the set for plugging in a pair of headphones. Use any 500 to 5000 ohm headphones. For headphone operation set the switch at PHONES.

**BAND SELECTOR CONTROL** - Set this control for the band you wish to tune.

**VOLUME CONTROL** - Turn this control clockwise to turn the set on. Allow about 30 seconds for the tubes to reach operating temperature and then advance the control to increase volume. To turn the set off, turn this control counter-clockwise until a click is heard.

**NOTE** - If the receiver does not operate after the 30 second warm up when connected to a DC source, the power plug should be reversed in the wall outlet to obtain proper polarity.

**RECEIVE - STANDBY SWITCH** - Set this switch at RECEIVE for radio reception. If you wish to silence the receiver without turning the set off, set the switch at STANDBY. To resume radio reception, simply return the switch to the RECEIVE position.

**TUNING KNOB** - Your receiver has been provided with two tuning knobs - The TUNING knob which operates the pointer on the left hand dial and a separate BAND SPREAD knob which operates the pointer on the right hand dial. The TUNING knob is for wide tuning and the BAND SPREAD knob for fine tuning. Use the TUNING knob to tune in the desired station. Tune for the clearest and strongest signal. If the signal is too strong, reduce it by means of the VOLUME control, not by using the TUNING knob. For code reception, adjust the TUNING knob for the desired pitch of the CW code signal when tuning in the station.

**IMPORTANT** - The dial readings will correspond to the exact station frequencies only if the BAND SPREAD dial pointer is set at 0.

**BAND SPREAD KNOB** - The BAND SPREAD knob permits you to accurately tune in stations on crowded bands by spreading them out so that they can be more easily separated. The BAND SPREAD knob can be used in two different ways. First, it may be left with the pointer at 5 while you partially tune in the desired station with the TUNING knob. Then, by "rocking" the BAND SPREAD knob back and forth (turn it a few degrees to the left and right through the desired station), you will be able to tune in the desired station with precision accuracy.

The second way to operate the BAND SPREAD knob is to use it to cover a group of stations. Set the BAND SPREAD knob so that the pointer reads 0 and then turn the TUNING knob to tune in the highest frequency station in the group. The other stations can be heard by slowly turning the BAND SPREAD knob from 0 to 100.

**BEST SHORTWAVE RECEPTION TABLE**

Band	Most Favorable Time	Most Favorable Distance
6-7 MC	Night - Winter	Day - 400 Miles - Night - Over 1500 Miles
9-10 MC	Day - Late Afternoon and Night - Winter	Over 500 Miles
11-12 MC	Evenings or Late Summer Afternoons	Day - Under 1500 Miles    Night - Over 1500 Miles
15-18 MC	Early Mornings and Summer Evenings	Over 1500 Miles

©John F. Rider

## SERVICE INSTRUCTIONS

### GENERAL SPECIFICATIONS

Tubes . . . . . 5 including 1 rectifier  
 Speaker . . . . . 5 inch PM  
 Voice Coil Impedance . . . . . 3.2 ohms  
 Headphone Output Impedance . . . 15 ohms  
 Antenna . . . . . Terminals for single wire or  
 doublet antenna. (See Page 2.)  
 Intermediate Frequency . . . . . 455 KC  
 Frequency Coverage . . . . . 540 KC - 32 MC  
 Power Supply . . . . . 105-125 volts DC or  
 60 cycles AC  
 Power Consumption . . . . . 30 watts

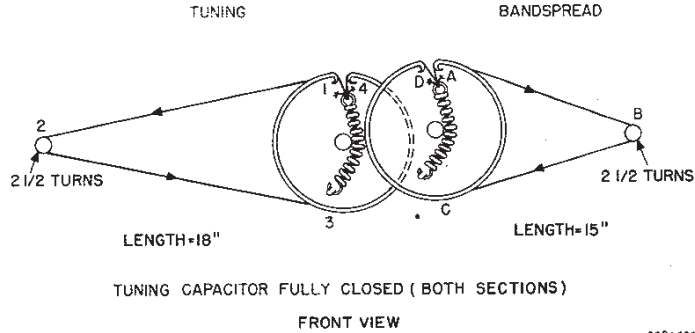

Fig. 2. Dial Cord Stringing Diagram

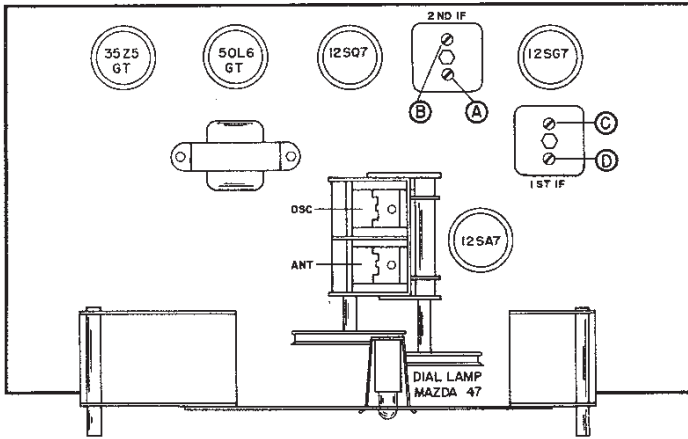

Fig. 3. Top View of Chassis Showing Location of Alignment Adjustments, Tubes and Dial Lamp

**DIAL CORD STRINGING** - Refer to Fig. 2 for the stringing diagram. Both sections of the tuning gang should be fully meshed. To restring the TUNING dial cord, tie one end of an 18 inch length of 30 lb. dial cord to the dial spring at 1 on the drive pulley. Follow the stringing sequence 1 through 4. At 4, stretch the spring and tie the cord securely to the spring. Cut off the excess cord and apply a drop of quick drying cement to the knot.

To restring the BAND SPREAD dial cord, cut a 15 inch length of dial cord and follow the procedure as explained above, starting at A and proceeding through D.

**TUBE AND DIAL LAMP REPLACEMENT** - Refer to Fig. 3 for the location of the tubes and dial lamp used in the receiver. To gain access to the tubes and lamp, remove the back cover from the cabinet. Before attempting to make any replacement, set the BAND SPREAD control fully clockwise and the TUNING control fully counterclockwise to prevent damage to the tuning gang. To replace a tube, insert the center guide pin into the center hole of the tube socket, rotate the tube until the key drops into position and then push down until the tube is held firmly in the socket. To make a dial lamp replacement, remove the dial lamp socket by compressing the side springs. Make replacement only with a type 47 pilot lamp.

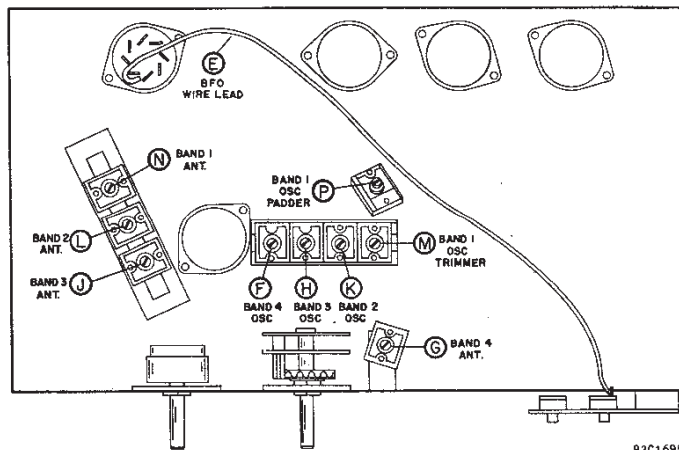

Fig. 4. Bottom View of Chassis Showing Location of Alignment Adjustments

### ALIGNMENT INSTRUCTIONS

- Use an amplitude modulated generator covering 455 KC to 30 MC. Use a modulated output for every step except Step 2.
- Connect output meter across speaker voice coil.
- Use a non-metallic alignment tool.
- Set the AM/CW switch at AM, (except for BFO adjustment), SPEAKER/PHONES switch at SPEAKER, VOLUME control at maximum, RECEIVE/STANDBY switch at RECEIVE and the BAND SPREAD control at 0.
- See Figs. 3 and 4 for location of alignment adjustments.

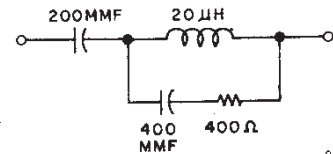

Fig. 5. RMA Dummy Antenna

Step	Signal Generator Connections	Generator Frequency	Band Selector Setting	Receiver Dial Setting	Adjust
<b>IF ALIGNMENT</b>					
1	High side thru a .01 mfd. capacitor to stator plates of front section of TUNING gang. Low side to chassis.	455 KC	1	1.0 MC	A, B, C and D for maximum output. Keep reducing gen. output so that the reading on the output meter does not exceed 50 milliwatts
<b>BFO ADJUSTMENT</b>					
*2	Same as Step 1.	455 KC (No Mod.)	1	1.0 MC	Set the AM/CW switch at CW. (Reset the switch at AM when Step 2 is completed.) For correct BFO operation, vary the coupling between lead E and pins 4 and 8 of the 12SG7 tube for a maximum beat note. Pushing lead E toward pin 4 increases the strength of the beat.
<b>RF ALIGNMENT</b>					
3	High side thru RMA dummy antenna (Fig. 5) to terminal A1 on back of chassis. Low side to chassis. Connect jumper between A2 and G.	30 MC	4	30 MC	F and G for maximum output as in Step 1.
4	Same as Step 3.	14 MC	3	14 MC	H and J for maximum output as in Step 1.
5	Same as Step 3.	5 MC	2	5 MC	K and L for maximum output as in Step 1.
6	Same as Step 3.	1500 KC	1	1.5 MC	M and N for maximum output as in Step 1.
		500 KC	1	.6 MC	P for maximum output as in Step 1.

\* Step 2 is usually unnecessary. Adjustment should be made ONLY if a weak beat note is obtained on strong CW signals indicating lack of coupling between wire lead E and pins 4 and 8 of the 12SG7.