

THE HALLICRAFTERS INC.

MODEL S20-R
Schematic, Notes

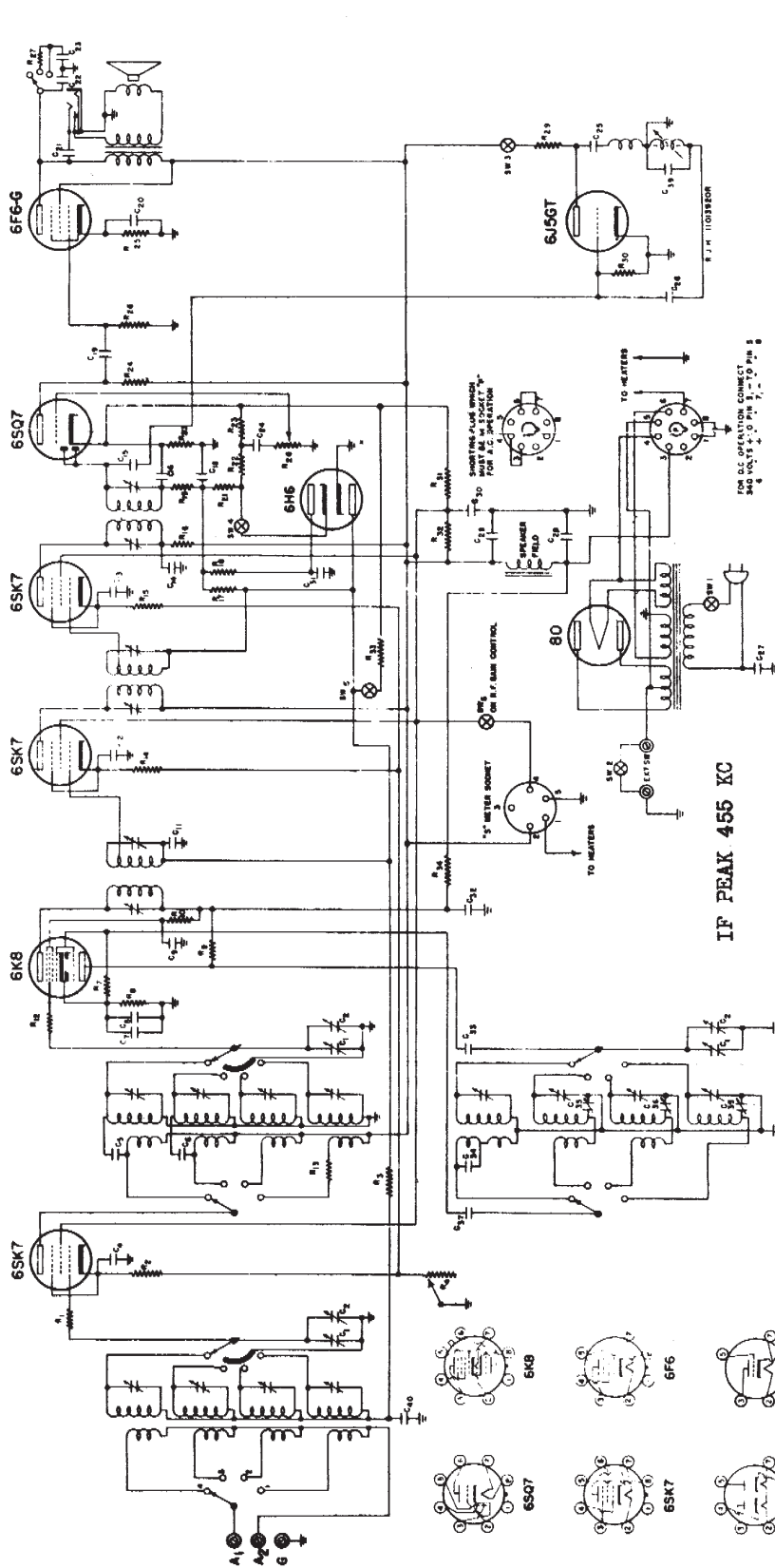

IF PEAK 455 KC

Unless otherwise specified the S20R Receiver operates on 100-125 volt 50-60 cycle current. A universal model is available on special order for operation on 110-250 volt, 25-60 cycle current.

TUBE LINE-UP

- 6SK7 R. F. Amplifier
- 6K8 1st Detector-Mixer H.F. Oscillator
- 6SK7 1st I.F. Amplifier
- 6SK7 2nd I.F. Amplifier
- 6SQ7 2nd Detector, A.V.C. 1st stage of audio
- 6F6G 2nd audio output stage
- 6H6 Automatic Noise Limiter
- 6J5GT Beat Frequency Oscillator
- 80 Rectifier

The Model S20R Receiver draws 65 watts at 115 volts 60 cycle alternating current.

BATTERIES

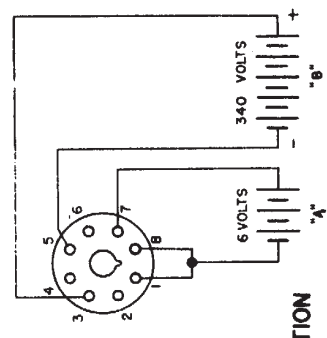

D C OPERATION

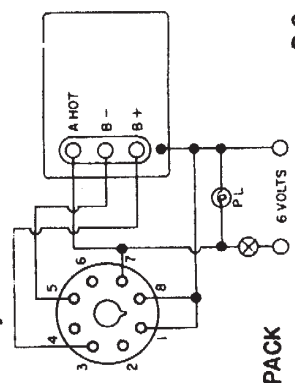

CONNECTIONS TO "PWR" SOCKET AFTER REMOVAL OF SHORTING PLUG

MODEL S20-R
Socket, Trimmers
Parts

THE HALLICRAFTERS INC.

FREQUENCY RANGE

Band	Coverage
1	540 KC to 1,770 KC
2	1.72 MC to 5.4 MC
3	5.3 MC to 15.7 MC
4	15.2 MC to 44. MC

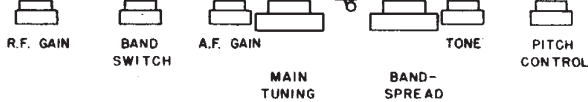
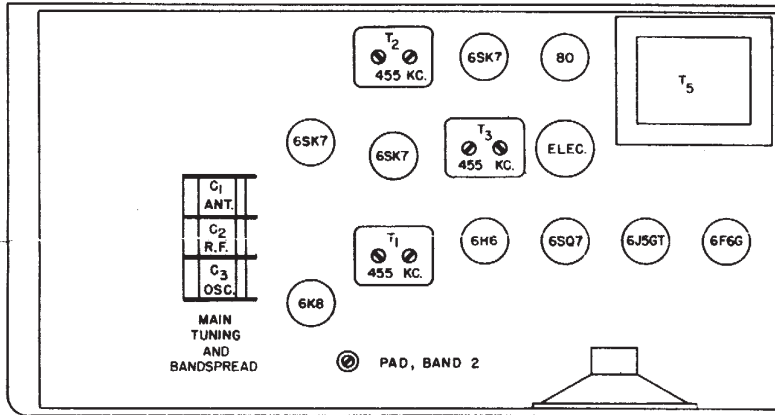
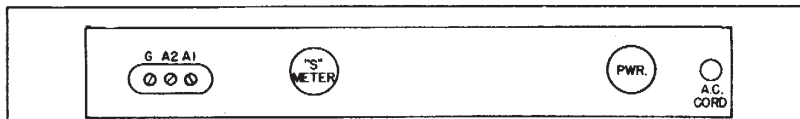
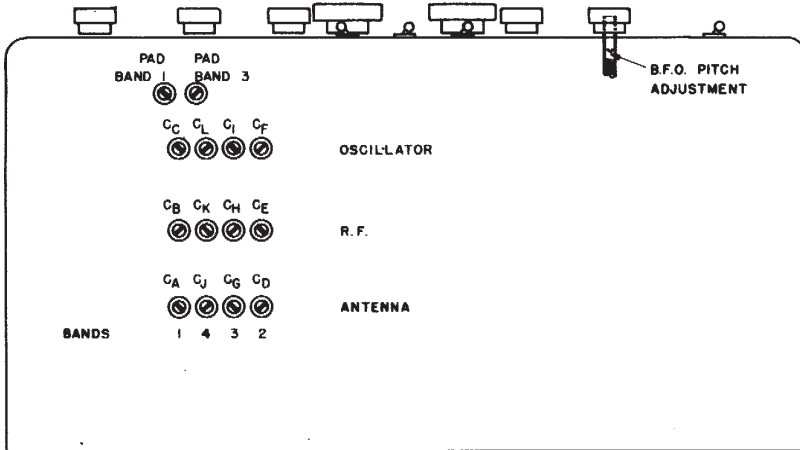

SWITCHES

- SW1 - AC On-Off On Tone Control Switch
- SW2 - Send Receive Switch
- SW3 - BFO On-Off
- SW4 - ANL On-Off
- SW5 - AVC On-Off
- SW6 - "S" Meter On R.F. Gain Control

RESISTORS

NO.	OHMS	WATTAGE
1	30	1/3
2	200	"
3	100,000	"
4	10,000	R.F. Gain
7	50,000	1/3
8	200	"
9	20,000	1
10	30,000	1
12	30	1/3
13	500	"
14	1,000	"
15	300	"
16	1,000	"
17	2,000,000	"
18	1,000,000	"
19	50,000	"
20	100	1/3
21	100,000	"
22	250,000	"
23	250,000	"
24	250,000	"
25	500	1
26	500,000	1/3
27	5,000	1
28	500,000	A.F. Gain
29	15,000	1-1/2
30	50,000	1/3
31	13,000	1-1/2
32	10,000	3
33	150	1/3
34	10,000	1-1/2

CONDENSERS

NO.	CAPACITY	VOLTAGE	TYPE
1	400 mmf	Main tuning	
2	27 "	Band Spread	
4	.05 mfd	200	
5	25 mmf		Ceramic
6	5 "		"
7	.002 mfd		Mica
8	.05 "	200	
9	.02 "	400	
11	.02 "	400	
12	.05 "	200	
13	.05 "	200	
14	.02 "	400	
15	2 mmf		Twisted Pair
16	50 "		Mica
18	50 "		"
19	.02 mfd	400	
20	10 "	25	Electrolytic
21	.01 "	400	
22	.01 "	800	
23	.02 mfd	600	
24	.02 "	400	
25	.01 "	400	
26	100 mmf		Mica
27	.01 mfd	800	
28	30 "	450	Electrolytic
29	10 "	400	"
30	.1 "	200	
31	.05 "	200	
32	10 "	450	Electrolytic
33	100 mmf		Ceramic
34	105 "		"
35	2400 and 450		Pad
36	1400 "		"
37	.002 mfd		Mica
39	.0005 "		"
40	.05 "	200	

THE HALLICRAFTERS INC.

MODEL S20-R
Alignment, Antenna Notes
MODEL SX-25
Antenna Notes

ANTENNA

The Sky Champion has an antenna input circuit which will allow the use of either a doublet or Marconi (inverted "L") antenna. The approximate antenna input impedance of the S20R is 400 ohms.

A very serviceable antenna will be the inverted "L", or Marconi type. This antenna should be approximately 75 feet long overall, including the lead-in to the set. Satisfactory operation of the Sky Champion is obtained throughout its tuning range with this type of antenna and because of that fact as well as its ease of construction it is highly recommended.

With the inverted "L" type of antenna A_2 must remain connected to G for best operation. While a ground connection is usually not necessary it might prove to be helpful in reducing noise. A cold water pipe or 6' foot rod driven in moist soil will be a very satisfactory ground when connected to the G terminal on the receiver. Connections to a radiator or gas piping are not recommended.

Should a doublet antenna be used it is suggested that a transmission line of 400 ohms value of impedance be constructed so that a most efficient transfer of energy is obtained. The commercially available all wave doublet antennas are usually provided with a coupling transformer which matches the transmission line to the receiver. This transformer connects to the A_1 and A_2 terminals on the antenna strip. The half-wave length-doublet antenna cut for a particular frequency can be computed by the following formula.

$$\text{Length in feet} = \frac{463}{\text{Frequency in megacycles}}$$

or for example, a half wave 20 meter or 14 megacycle antenna would be

$$\frac{463}{14} \text{ or } 33.7 \text{ feet long overall}$$

This type of antenna is broken in the center with an insulator and has the transmission line connected to each resulting quarter wave section at that point. This antenna is a very good performer, in a direction broadside to its length, only on the relatively narrow group of frequencies for which it was cut. It does not function well on harmonic frequencies.

When using either type of doublet antennas the transmission line should be connected to A_1 and A_2 binding posts. The wire connecting the A_2 to ground or G can be left connected if the performance of the receiver is improved.

ALIGNMENT PROCEDURE

455 KC, Intermediate-Frequency Alignment. B.F.O. switch in the "OFF" position.
Have the controls set as follows: Set band switch to #2 band.
AF and RF gain controls for maximum volume. Set main dial to 2 megacycles, band spread to zero.

Remove 6K8 grid cap and connect the hot side of your 455 KC generator to this tube. Connect the ground terminal of the signal generator to the chassis of the receiver. Now feed a 455 KC signal into the receiver. Adjust all I.F. transformer trimmers on T1, T2, T3, for maximum gain.

R. F. ALIGNMENT

Re-connect the grid cap to the 6K8 tube. Connect the hot side of the generator to the A_1 antenna terminal on the rear of the chassis through a 400 ohm resistor. Be sure a jumper is connected to A_2 and G. Leave signal generator ground connected to the chassis of the receiver.

The location of the following trimmers and padders can be determined by referring to the top and bottom chassis views. All pad adjustments are for the low frequency end of each band while the trimmers are for the high frequency ends.

In order to get at the RF trimmers the guarantee card can be removed by placing a knife under the small snap fasteners holding it in place. So that most satisfactory adjustment of the trimmers and padders can be made, it is advisable to "Rock" the condenser gang across the signal being delivered by the generator until that particular circuit has been accurately peaked at all frequencies except 1400 KC and 4 MC.

Bands	Trim at	Pad at
1	1400 KC Adjust $C_A C_B C_C$	600 KC Adjust Pad Band 1
2	4 MC Adjust $C_D C_E C_F$	2 MC Adjust Pad Band 2 (Top Chassis)
3	14 MC Adjust $C_G C_H C_I$	7 MC Adjust Pad Band 3
4	34 MC Adjust $C_J C_K C_L$	17 MC No pad on this Band