

STEREO TWIN CASSETTE DECK KX-W900/W900U

SERVICE MANUAL

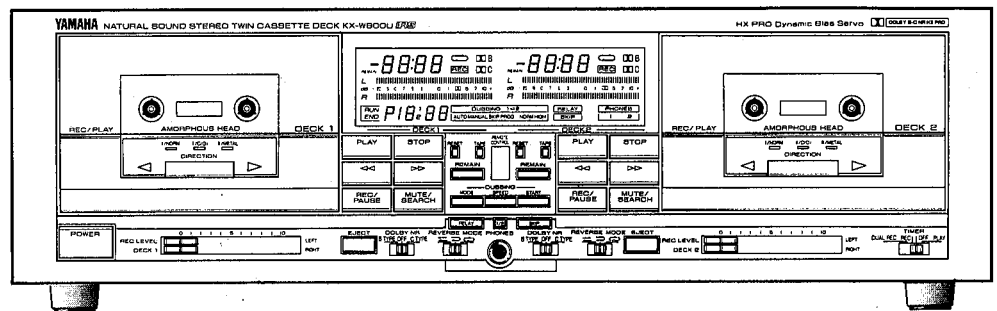
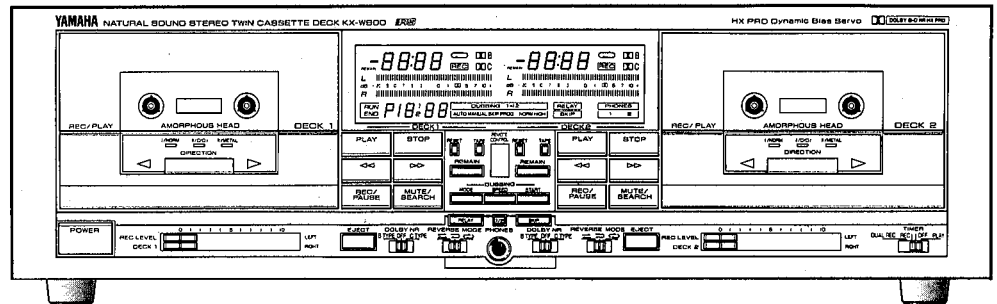
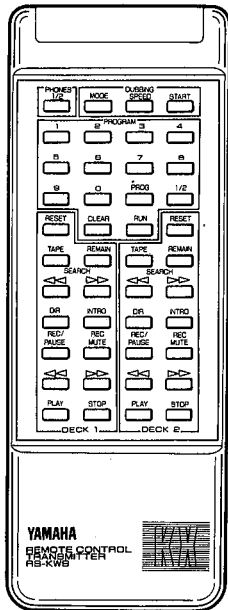

IMPORTANT NOTICE

This manual has been provided for the use of authorized Yamaha Retailers and their service personnel. It has been assumed that basic service procedures inherent to the industry, and more specifically Yamaha Products, are already known and understood by the users, and have therefore not been restated.

WARNING: Failure to follow appropriate service and safety procedures when servicing this product may result in personal injury, destruction of expensive components and failure of the product to perform as specified. For these reasons, we advise all Yamaha product owners that all service required should be performed by an authorized Yamaha Retailer or the appointed service representative.

IMPORTANT: The presentation or sale of this manual to any individual or firm does not constitute authorization, certification, recognition of any applicable technical capabilities, or establish a principle-agent relationship of any form.

The data provided is believed to be accurate and applicable to the unit(s) indicated on the cover. The research, engineering, and service departments of Yamaha are continually striving to improve Yamaha products. Modifications are, therefore, inevitable and specifications are subject to change without notice or obligation to retrofit. Should any discrepancy appear to exist, please contact the distributor's Service Division.

WARNING: Static discharges can destroy expensive components. Discharge any static electricity your body may have accumulated by grounding yourself to the ground buss in the unit (heavy gauge black wires connect to this buss).

IMPORTANT: Turn the unit OFF during disassembly and parts replacement. Recheck all work before you apply power to the unit.

TO SERVICE PERSONNEL	1
SPECIFICATIONS	1
REAR PANELS	2
INTERNAL VIEW	3
DISASSEMBLY PROCEDURES	3~5
ADJUSTMENT	6~9
μCOM DATA	10~14
DISPLAY Pin Connection	15

TIMING CHART	16/17
IC BLOCK	18~20
WIRING	21
BLOCK DIAGRAM	22/23
PRINTED CIRCUIT BOARD	24~29
SCHEMATIC DIAGRAM	30~32
PARTS LIST	33~45
REMOTE CONTROL TRANSMITTER	46/47

KX-W900/W900U



■ TO SERVICE PERSONNEL

1. Critical Components Information.
Components having special characteristics are marked  and must be replaced with parts having specifications equal to those originally installed.
2. Leakage Current Measurement (For 120V Model Only).
When service has been completed, it is imperative that you verify that all exposed conductive surfaces are properly insulated from supply circuits.
 - Meter impedance should be equivalent to 1500 ohm shunted by 0.15μF.
 - Leakage current must not exceed 0.5mA.
 - Be sure to test for leakage with the AC plug in both polarities.

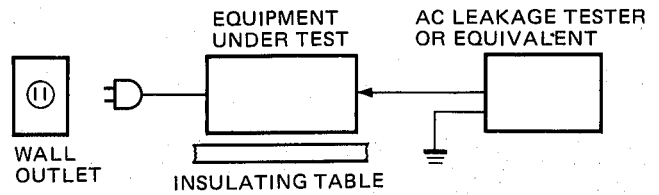

■ SPECIFICATIONS

Type Auto reverse 4-Track 2-channel recording and playback stereo twin cassette deck

Heads

Rec/PB Amorphous x 2
Erase Double Gap Ferrite x 2

Motors

Capstan DC servo motor x 2
Reel DC motor x 2

Wow and Flutter No more than ±0.08% W. Peak
0.05% W. RMS

Fast Winding Time About (85sec.)

Frequency Response

Normal (-20dB) ... 20-17000Hz, ±3dB
Chrome (-20dB) ... 20-19000Hz, ±3dB
Metal (-20dB) ... 20-20000Hz, ±3dB

S/N Ratio (3rd harmonic distortion: Weighted)

NR OFF better than 58dB
Dolby B NR better than 66dB
Dolby C NR better than 74dB

Harmonic Distortion (315Hz, 3rd) .. No more than 1%

Channel Separate (3150Hz) More than 40dB

Crosstalk (125Hz) More than 55dB

Input Sensitivity/Impedance

Line 50mV/50kΩ

Output Level

Line 360mV/1kΩ
Headphones 0.3mW/8Ω

Power Supplies

U, C models 120V AC60Hz
G model 220V AC50Hz
A, B models 240V AC50Hz
R model 110,120,220,240V AC 50/60Hz

Power Consumption ... 28W

Dimensions (WxHxD) .. 435x132x305mm
(17-1/8"x5-3/16"x12")

Weight 7.0kg (15 lbs. 7oz)

Specifications subject to change without notice.

- (U) U.S.A. model
- (C) Canadian model
- (A) Australian model
- (G) European model
- (B) British model
- (R) Other model

REAR PANELS

U, C models

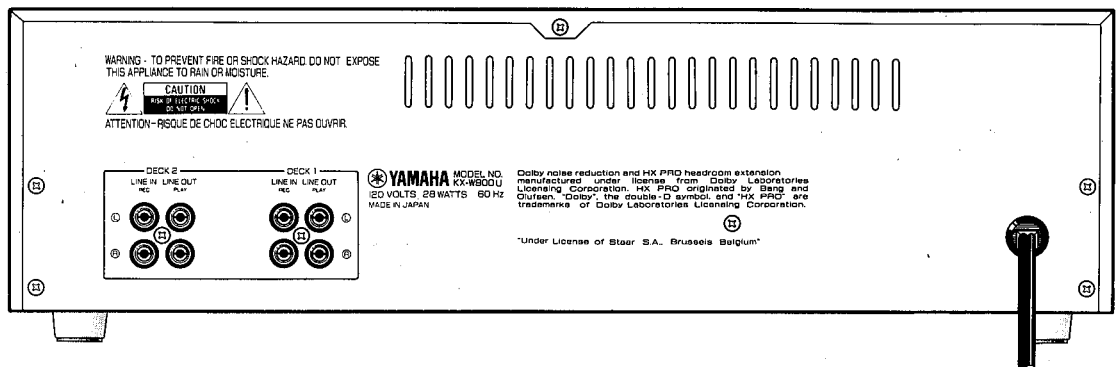

A, B models

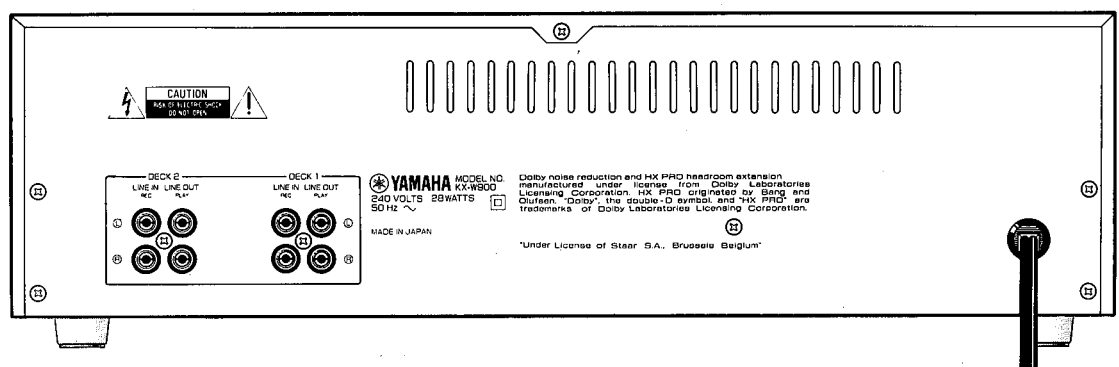

G model

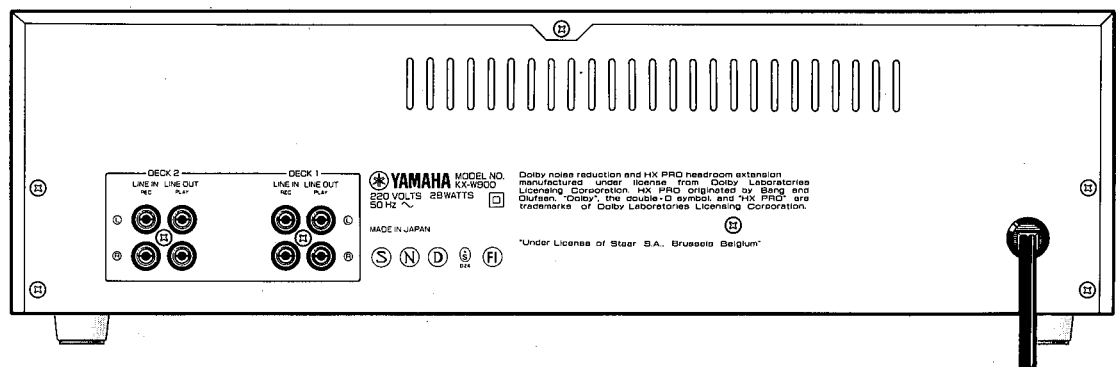

R model

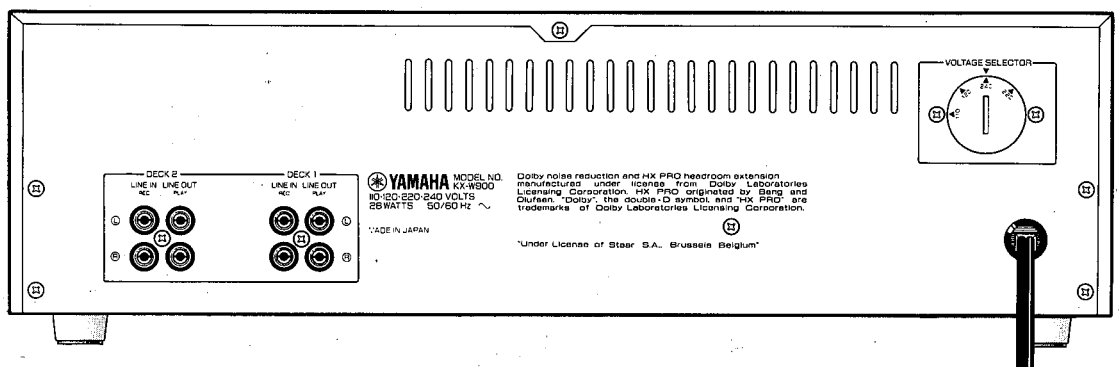

KX-W900/W900U

INTERNAL VIEW

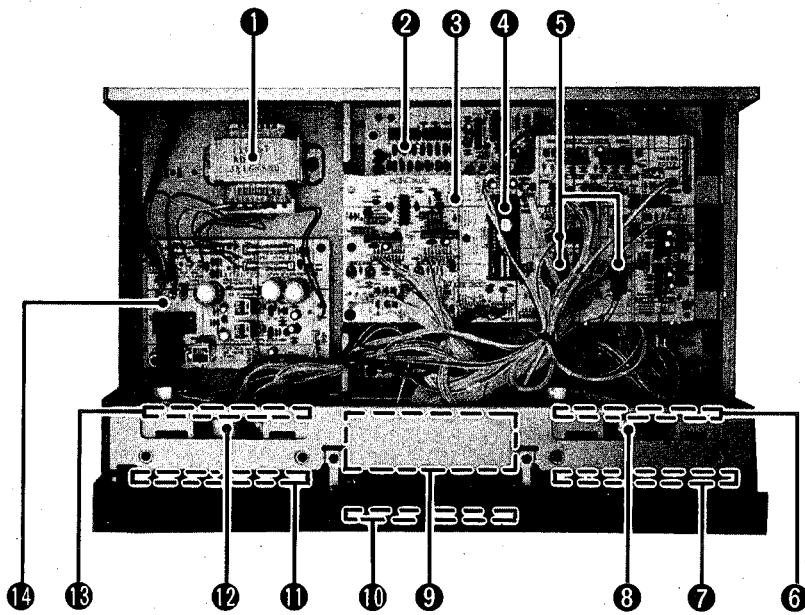

- ① POWER TRANSFORMER
- ② MAIN CIRCUIT BOARD
- ③ SUB CIRCUIT BOARD (1)
- ④ μ COM IC304 (MN1756-YAA)
- ⑤ CONTROL IC IC305, 306, 307 (LC7800)
- ⑥ OPERATION CIRCUIT BOARD (3)
- ⑦ SUB CIRCUIT BOARD (4)
- ⑧ DECK-2 (MECHANISM UNIT)
- ⑨ LCD UNIT
- ⑩ OPERATION CIRCUIT BOARD (1)
- ⑪ SUB CIRCUIT BOARD (3)
- ⑫ DECK-1 (MECHANISM UNIT)
- ⑬ OPERATION CIRCUIT BOARD (2)
- ⑭ SUB CIRCUIT BOARD (2)

DISASSEMBLY PROCEDURES (Remove parts in disassembly order as numbered)

DISASSEMBLY PROCEDURES OF CABINET PARTS

1. Removal of Top Cover.

a. Remove 5 screws (①) in Fig. 1.

2. Removal of Bottom Cover.

a. Remove 6 screws (②) in Fig. 1.

3. Removal of Front Panel.

a. Remove 7 screws (③) in Fig. 1.

b. When completely removing the PC board, disconnect all of the connectors.

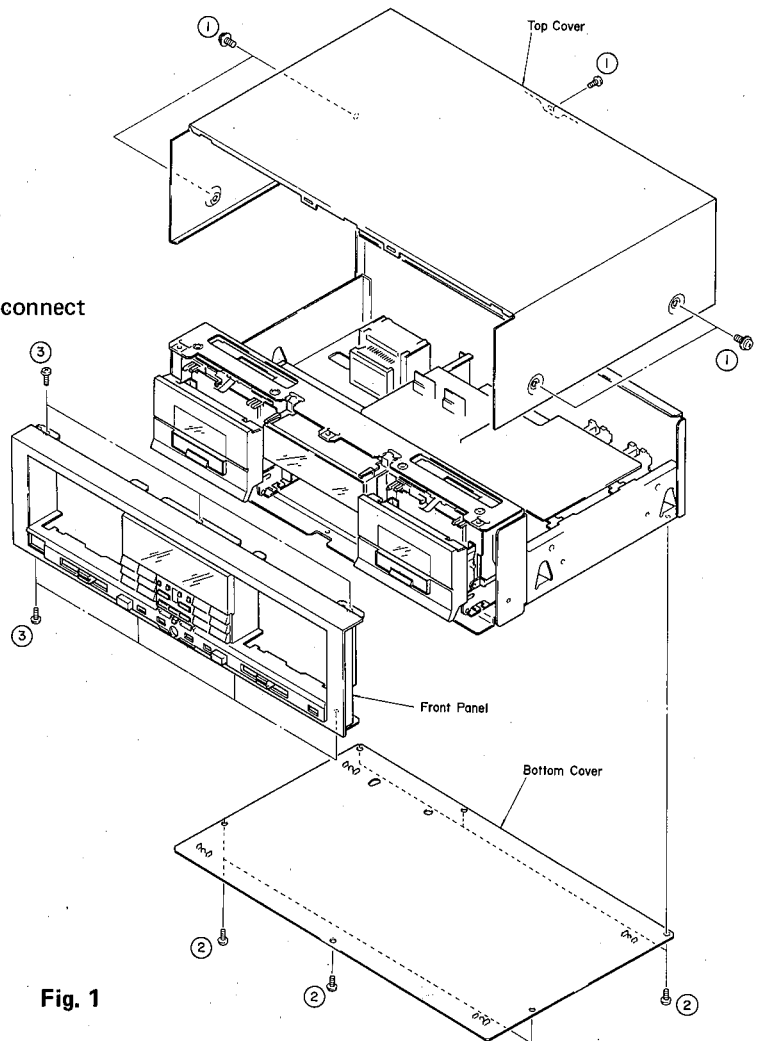

Fig. 1

DISASSEMBLY PROCEDURES OF CASSETTE MECHANISM

1. Removal of Cassette Mechanism Unit. (DECK-1.2)

- Remove the Top Cover.
- Remove the Bottom Cover.
- Remove the Front Panel.
- Remove 4 screws (4) in Fig. 2.
- Pull off the mechanism with to the front side gently.
- When completely removing the PC board, disconnect all of the connectors.

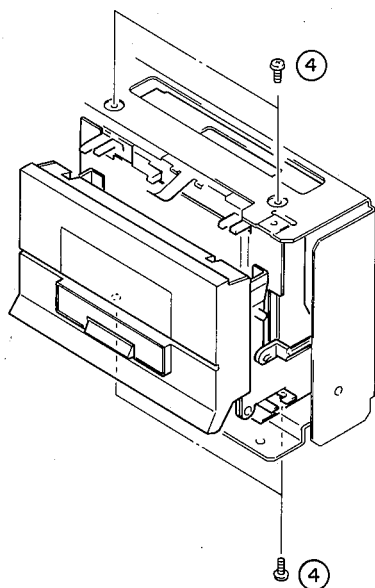

Fig. 2

2. Removal of Housing Flame

- Remove the Cassette Lid in Fig. 3.
- Remove screw (5) in Fig. 3, then remove the blind plate.
- Remove section (A) by lightly pressing the housing frame against the mechanism side after closing the housing frame.
- Push section (B) on the underside of the housing frame in the direction of the arrow to remove it. At this time, pay attention to the spring on the left side.

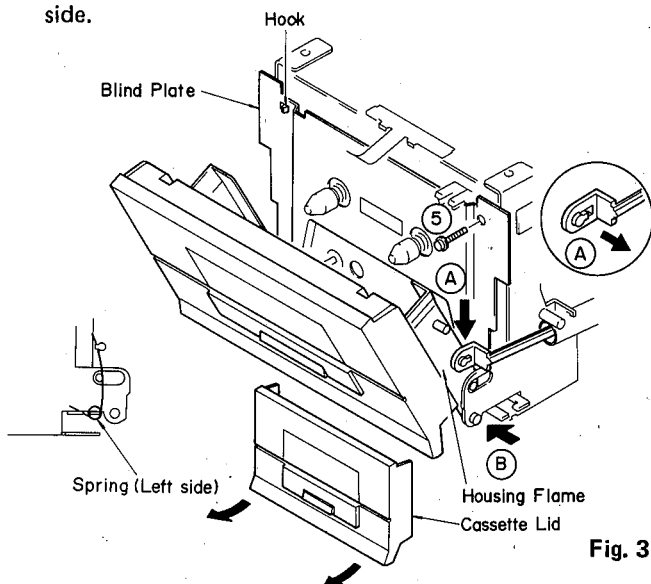

Fig. 3

3. Removal of Pinch Roller

- Remove the Ering (6) in Fig. 4.
*Be sure that the pinch roller SPRING is in the correct position when attached.

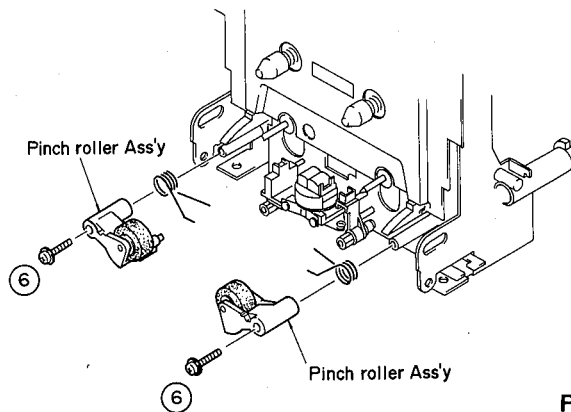

Fig. 4

4. Removal of Head Unit

- Straighten the bent lug and remove the lead wire in Fig. 6
- Loosen 2 screws (7) Fig. 5 and remove the lead holder.
- Remove hexagonal nut (8) in Fig. 6. (Tape Guide Sensor unit)
- Remove 2 screws (9) in Fig. 6 and then remove the Head Unit.

*Perform tape guide sensor unit adjustments and azimuth adjustments when attaching the head unit.

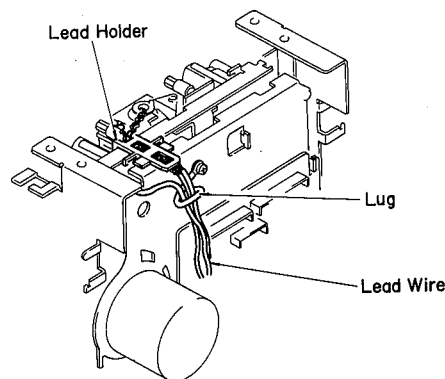

Fig. 5

(View of lower part of cassette mechanism)

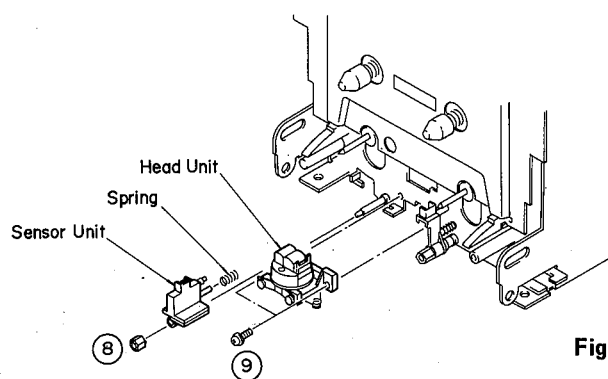

Fig. 6

5. Removal of Main Motor and Flywheel Belt.

- a. Remove the spring (12) in Fig. 7.
- b. Remove 3 screws (10).
- c. Disconnect the Capstan motor lead wiring.
- d. Remove the back plate slowly.
(Can be removed with Main motor attached.)
- e. Remove the Flywheel belt.
- f. Remove 3 screws (11) in Fig. 7, then remove the Main motor.

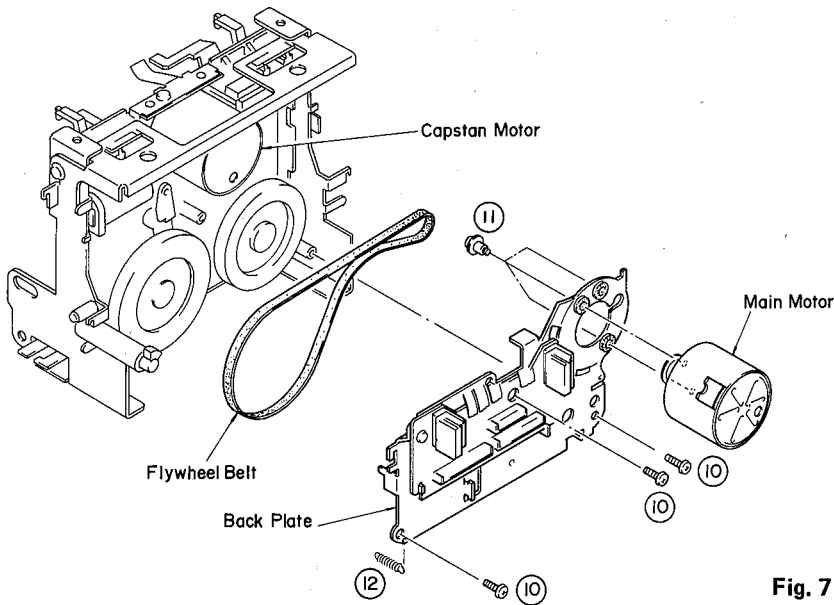
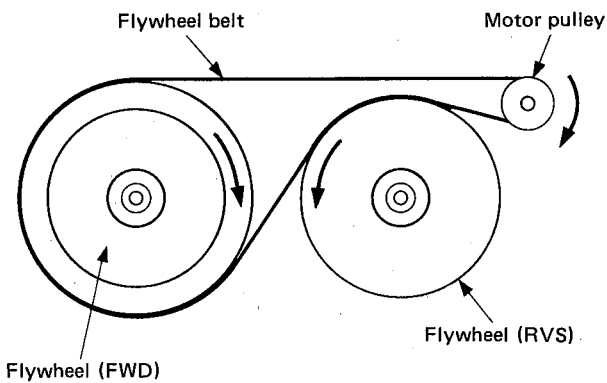

Fig. 7

● **How to hang the Flywheel belt**



(The pulley is shown from backward position.)

KX-W900/W900U

ADJUSTMENTS

1. Before adjustment:

- Make sure that AC line voltage comes within

Models	AC line voltage
U, C	120V ± 10%
G	220V ± 10%
A, B	240V ± 10%

- Since head magnetization, dust accumulations, etc. are likely to introduce error in the various characteristics, it is very important that the heads are properly demagnetized and cleaned.

2. Instruments required

- Audio frequency oscillator (AF OSC)
- ACVM or dual channel ACVM
- Wow/flutter meter
- Oscilloscope
- Torque meter
 - TW-2111 (TX911580) TW-2412 (TX911640)
 - TW-2121 (TX911570) TW-2422 (TX911630)
 - CT160L (TX911120)

- DCVM
- Mirror Cassette MC-109C

3. Test tape required

- MTT-111N (TX911650): Tape Speed (Normal)
- TCC-211 (TX911550): Tape Speed (High Speed)
- MTT-114N (TX911680): Azimuth
- MTT-212CN (TX911670): Playback Level
- MTT-212N (TX911660): Playback Level
- MTT-256 (TX911300): Playback Frequency Response (LH) (CrO₂)
- MTT356 (TX911310): Playback Frequency Response (LH) (CrO₂)
- Reference tape
 - Normal (LH) : TDK AC223 (TX911600)
 - CrO₂ : TDK SA-60 or TDK AC513 (TX911610)
 - METAL : TDK AC712 (TX911590)

MECHANICAL ADJUSTMENT

Step	Adjustment item	Tape	Mode	Measurement Conditions	Rating	Adjustment Part	Remarks
1	Tape speed (High)	TCC-211 1.5kHz, -10dB	PLAY	DECK-1: 3000 ⁺¹⁵ ₋₁₀ Hz	After PLAY mode is engaged, make a short-circuit between TP303 and TP304.	VR301 (DECK-1) VR302 (DECK-2)	Adjust double-speed mode first.
				DECK-2: 3000 ⁺²⁰ ₋₅ Hz			
2	Tape speed (Normal)	MTT-111N 3kHz, -10dB	PLAY	Same as in step 1.		VR303 (DECK-1) VR304 (DECK-2)	
3	Azimuth	MTT-114N 10kHz, -10dB	PLAY	In either FWD or RVS (REV), both channel outputs should be maximum in level and in the same phase. (Use the same side of the test tape for both FWD and REV.)		Azimuth adjust-screw (Fig. A)	After adjustment, be sure to lock the screw with screw lock adhesive.
4	Leader tape Sensor	TDK: AD120 Magnetic face	PLAY	TP301, TP302 Less than 0.5V	In FWD play, measure DC voltage between the test points. G ↔ TP301 (DECK-1) G ↔ TP302 (DECK-2)	VR309 (DECK-1) VR310 (DECK-2)	Play back the magnetized side and the leader tape section alternately, and adjust so that each measurement meets the standard value.
		MAXEL: Leader tape section		TP301, TP302 More than 1.0V			

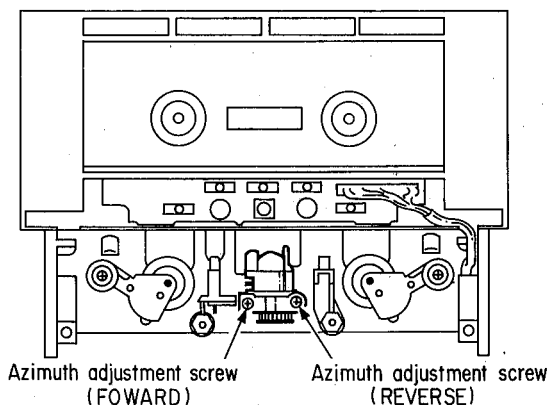

Fig. A

KX-W900/W900U

● ELECTRICAL ADJUSTMENT

- Proceed with the following adjustment after having finished the mechanical adjustment.
- Playback section

Step	Item to be adjusted	Tape	Instrument required	Mode	Measurement conditions	Points of measurement	Adjustment part	Rating
1	Playback level	MTT-212CN (160nwb/m)	ACVM	PLAY		LINE OUT	DECK 1 VR1 (Lch) VR2 (Rch) DECK 2 VR7 (Lch) VR8 (Rch)	360 ± 25mV (Relay SW --- OFF)
2	Confirmation of playback frequency response	Test tape for frequency check. MTT-256 (LH: 3180µs + 120µs) MTT-356 (CrO ₂ : 3180µs + 70µs)	ACVM Oscilloscope	PLAY		LINE OUT		Check that the 10kHz playback level lies within 0 ± 3dB of the 315Hz playback level. (Fig. C)

● PLAYBACK FREQUENCY RESPONSE

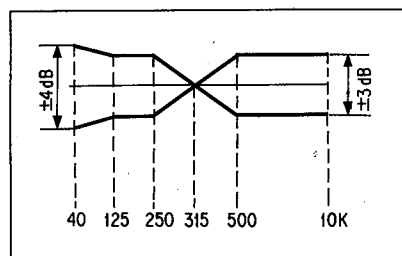

Fig. C

● Recording section

Step	Item to be adjusted	Tape	Instrument required	Mode	Measurement conditions	Points of measurement	Adjustment part	Rating
1	Meter		ACVM AF OSC	REC/ PAUSE	1 REC LEVEL → MAX. 2 Apply a 1kHz signal to LINE IN terminals. Set the AF OSC output level so that LINE OUT voltage is 360mV.	Peak level meter	DECK 2 VR305 (Lch) VR306 (Rch) DECK 1 VR307 (Lch) VR308 (Rch)	Adjust VR305, 307 and VR306, 308 to the lowest level where the 0dB display part of the level meter light up.
2	Bias Oscillation level	METAL	ACVM	REC PLAY	VR3, 4, 9, 10 → MAX.	TP5, 6 TP7 TP1 ~ 4	L-EH1 (T1) L-EH2 (T2) L-HXPRO (T4) L1, 2, 13, 14	Adjust so that oscillation output is maximum. (Relay SW --- OFF)
3	Recording level		ACVM AFOSC	REC PLAY	Apply a 1kHz signal to LINE IN terminals. Set the REC LEVEL knob so that LINE OUT voltage is 360mV.	LINE OUT	DECK 1 VR5 (Lch) VR6 (Rch) DECK 2 VR11 (Lch) VR12 (Rch)	Set the same level of the record and playback level. (360mV ± 25mV)
4	Record Bias (Total frequency response)	NORMAL CrO ₂ METAL	ACVM AFOSC	REC PLAY	Apply a 1kHz signal to LINE IN terminals. Set the REC LEVEL knob so that LINE OUT voltage is 30mV (-20dBV).	LINE OUT	DECK 1 VR3 (Lch) VR4 (Rch) DECK 2 VR9 (Lch) VR10 (Rch)	Set the same level of the record and playback level. (Fig. D)

● TOTAL FREQUENCY RESPONSE (-20dB)

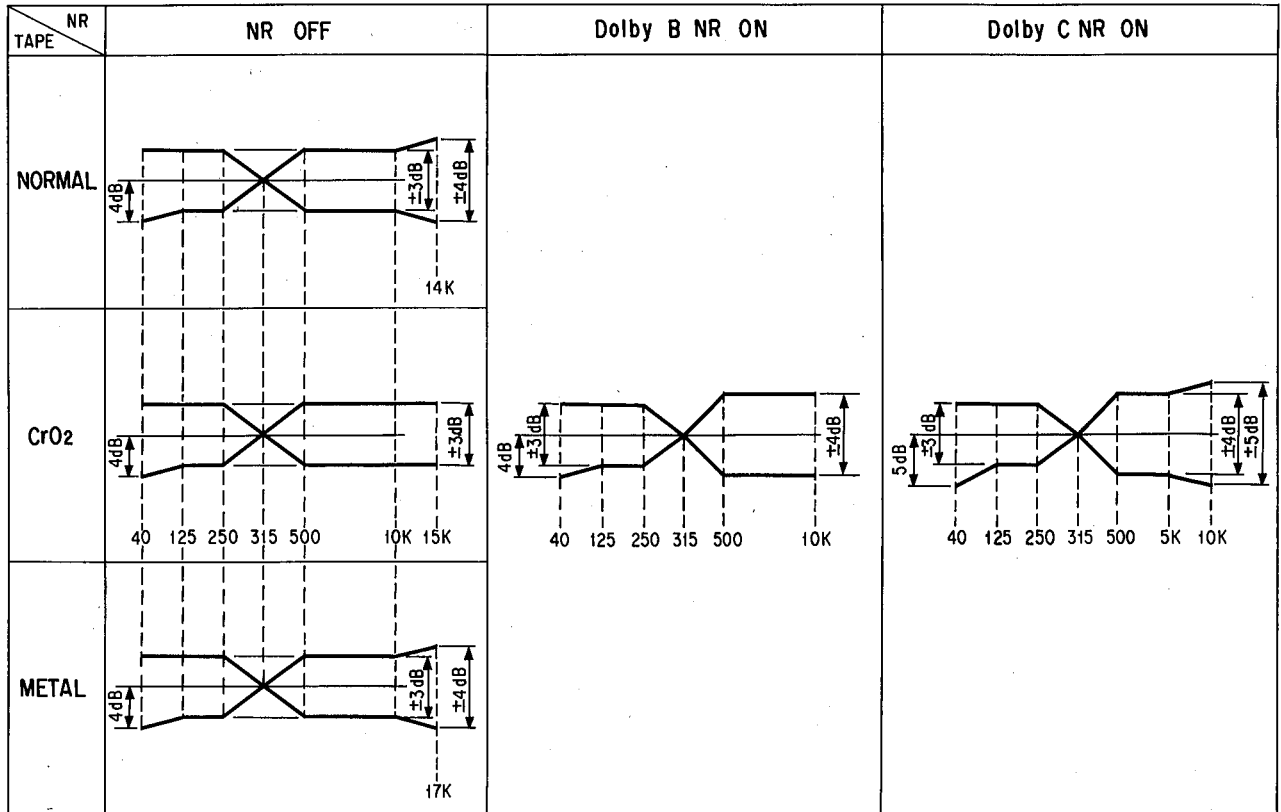

Fig. D

● COPY RESPONSE

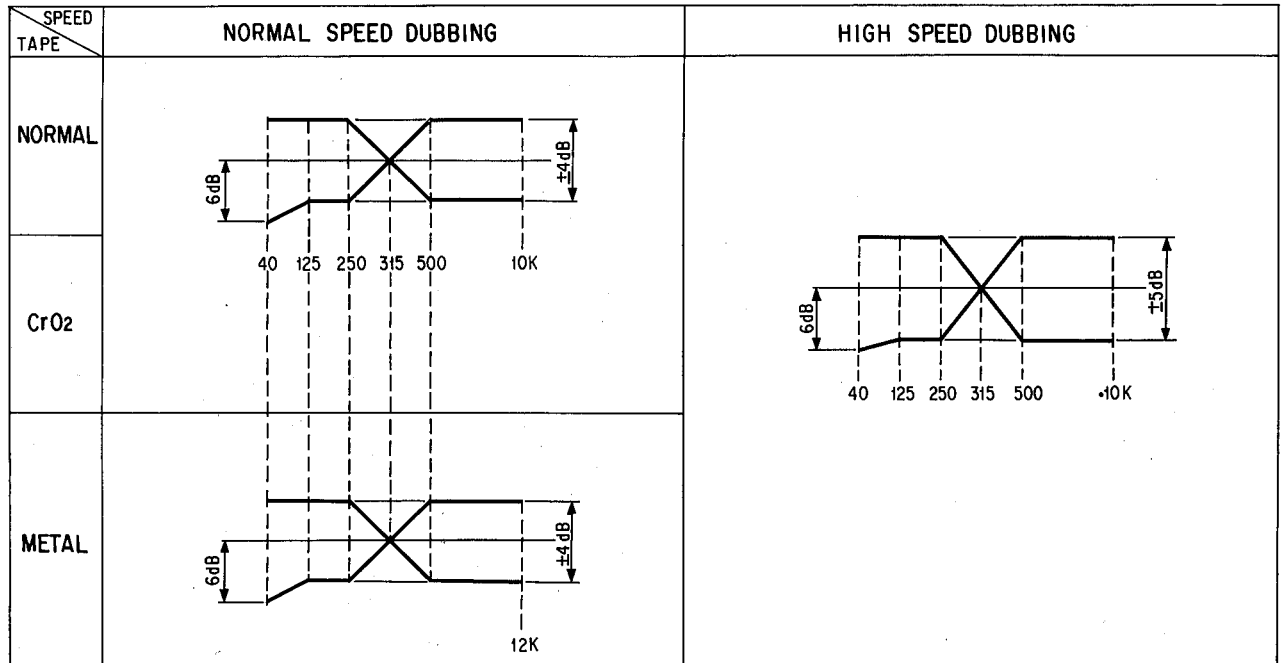
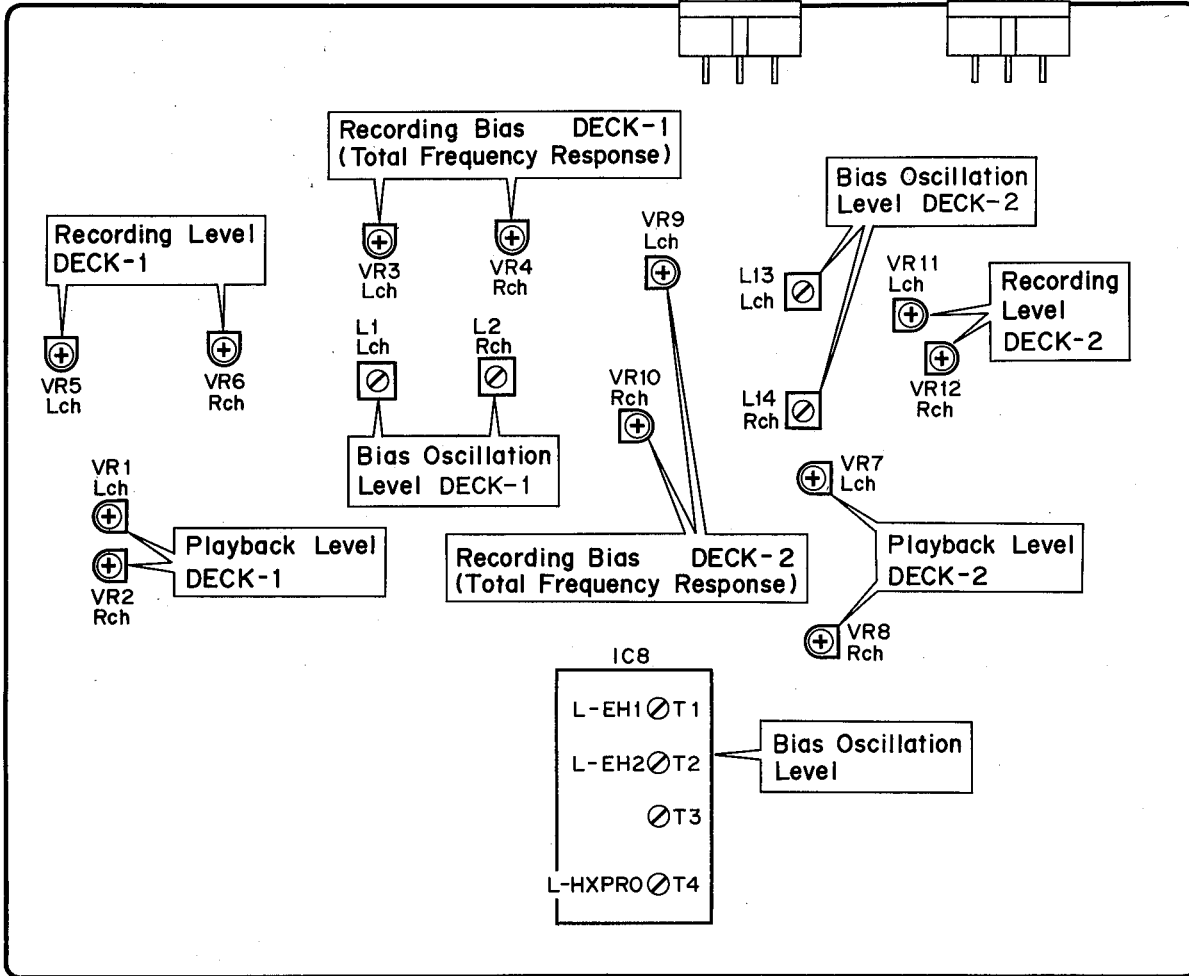

Fig. E

KX-W900/W900U

● TEST POINT

MAIN C.B



SUB C.B (1)

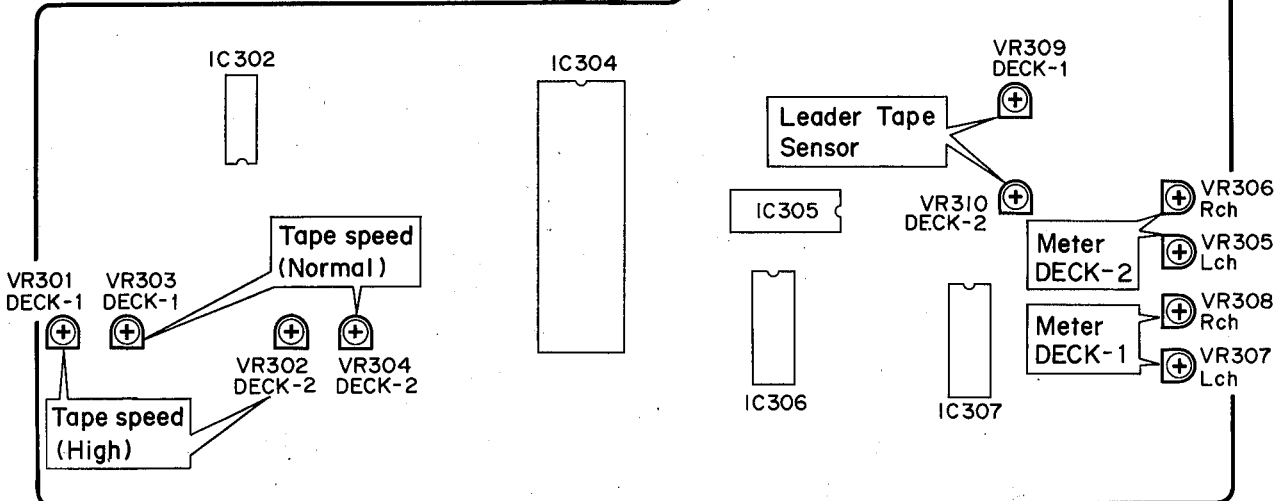

Fig. 8

μ-COM DATA
• IC304: MN1756-YAA (ROM 6K × 10 bit)

PIN NO.	NAME	FUNCTION	LEVEL
1	V _{DD}	+5V	
2	TCIB	+5V	
3	TRQ0	POWER OFF DET INPUT	
4	TRQ1	GND	
5	P00	SOLENOID ATTRACTION OUTPUT	L: ON
6	P01	CAPSTAN MOTOR OUTPUT	L: ON
7	P02	REEL MOTOR (+) OUTPUT	L: ▷
8	P03	REEL MOTOR (-) OUTPUT	L: ◁
9	P10	SOLENOID ATTRACTION OUTPUT	L: ON
10	P11	CAPSTAN MOTOR OUTPUT	L: ON
11	P12	REEL MOTOR (+) OUTPUT	L: ▷
12	P13	REEL MOTOR (-) OUTPUT	L: ◁
13	P20	SOLENOID HOLD OUTPUT DECK-1	L: HOLD
14	P21	SOLENOID HOLD OUTPUT DECK-2	L: HOLD
15	P22	DUBBING HIGH OUTPUT	L: ON
16	P23	DUBBING OUTPUT	L: ON
17	P30	REC/PLAY OUTPUT	H: REC
18	P31	RELAY OUTPUT	L: ON
19	P32	LINE MUTE OUTPUT	L: ON
20	P33	REC MUTE OUTPUT	L: ON
21	P40	REC BIAS OUTPUT	H: ON
22	P41	NORMAL OUTPUT	L: SELECT
23	P42	CrO ₂ OUTPUT	L: SELECT
24	P43	METAL OUTPUT	L: SELECT
25	P50	REC/PLAY OUTPUT	H: REC
26	P51	HEADPHONE OUTPUT	H: 2
27	P52	LINE MUTE OUTPUT	L: ON
28	P53	REC MUTE OUTPUT	L: ON
29	P60	REC BIAS OUTPUT	H: ON
30	P61	NORMAL OUTPUT	L: SELECT
31	P62	CrO ₂ OUTPUT	L: SELECT
32	P63	METAL OUTPUT	L: SELECT
33	P70	LCD DRIVE PORT.	D1
34	P71		CL
35	P72		CE2
36	P73		CE1
37	P80	DIRECTION OUTPUT DECK -1	H: REV
38	P81	DIRECTION OUTPUT DECK-2	H: REV
39	P82	CHIP SELECT	
40	P83		
41	P90	SCAN SIG.	
42	P91		
43	P92		
44	P93		
45	EXPS	+5V	
46	PA0	MATRIX INPUT	
47	PA1		
48	PA2		
49	PA3		
50	PB0	REEL PULSE(T) INPUT DECK-1	
51	PB1	REEL PULSE(S) INPUT DECK-1	
52	PB2	REEL PULSE(T) INPUT DECK-2	
53	PB3	REEL PULSE(S) INPUT DECK-2	
54	PC0	MUSIC SENSOR PULSE INPUT DECK-1	H: BLANK
55	PC1	MUSIC SENSOR PULSE INPUT DECK-2	H: BLANK
56	PC2	GND	

PIN NO.	NAME	FUNCTION	LEVEL
57	PC3	REMOTE CONTROL INPUT	
58	RST	RST INPUT	
59	SYNC	OPEN	
60	X2	OPEN	
61	X1	+5V	
62	V _{SS}	GND	
63	OSC2	EXCLK OUTPUT	
64	OSC1	EXCLK INPUT	

● IC304: MN1756-YAA (ROM 6K x 10 bit)

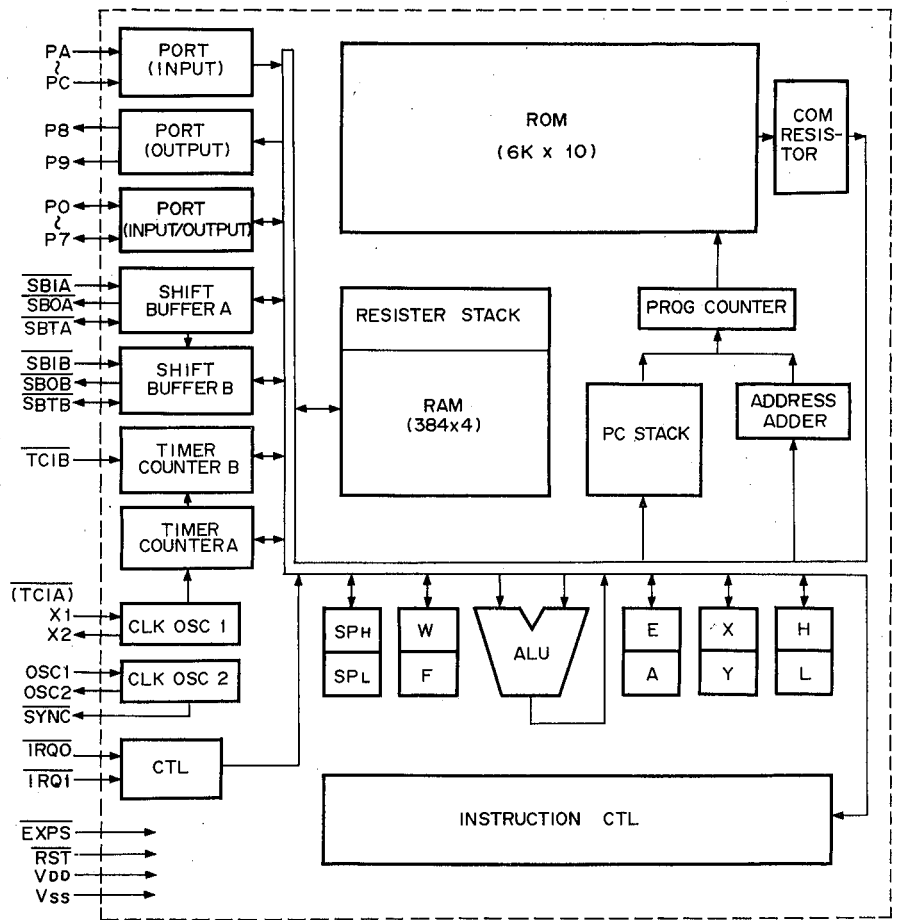
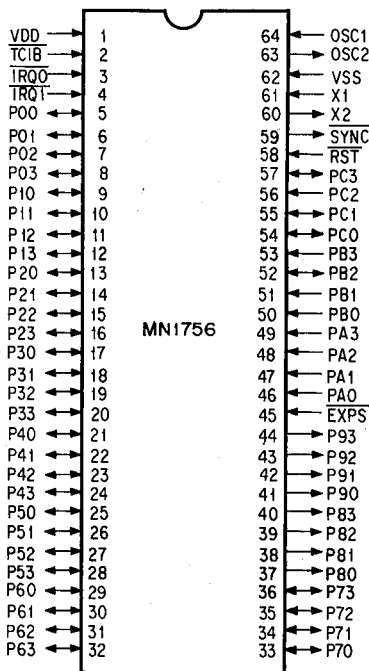

KX-W900/W900U

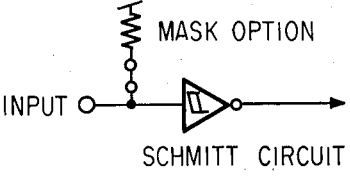
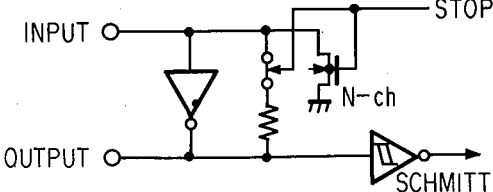
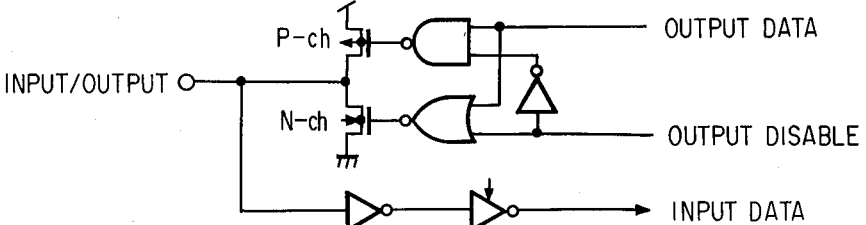
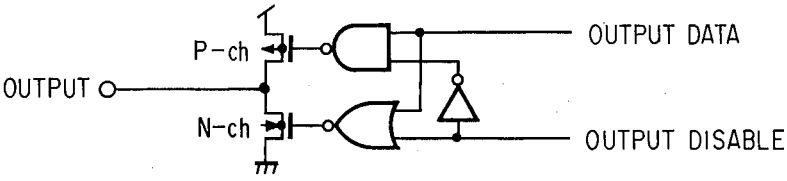
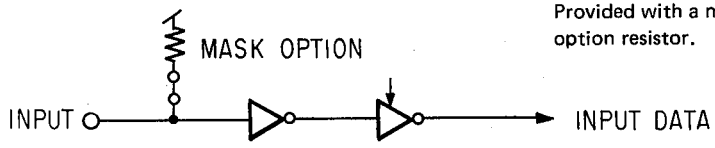
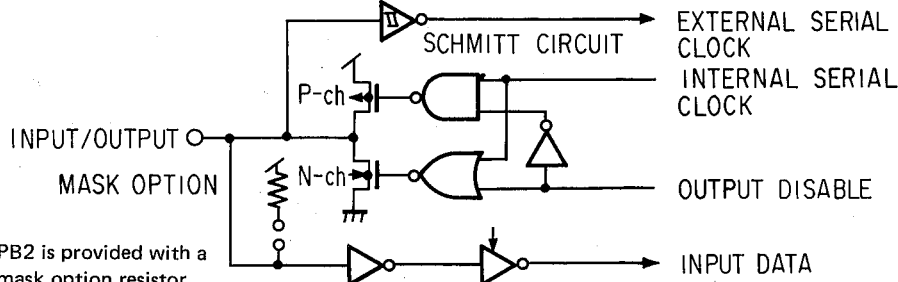
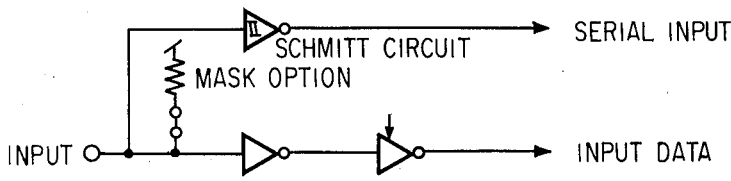
Terminal Name	Input / Output Circuit Design
$\overline{\text{RST}}$ $\overline{\text{TRQ0}}$	 <p>$\overline{\text{RST}}$ is provided with a mask option resistor.</p>
OSC1 OSC2	
P00~P73 PC0 PC3	
P00~P93	
PA0~PA3 PB0 PB1	 <p>Provided with a mask option resistor.</p>
PB2 PC1	 <p>PB2 is provided with a mask option resistor.</p>
PB3 PC2	 <p>PB3 is provided with a mask option resistor.</p>

KX-W900/W900U

● MATRIX INPUT (IC305~307: LC7800)

Chip Select (P82, P83) 01: Mechanism-1 IC305
 11: Mechanism-2 IC307

Digit	Input Port	Name	Function	LC7800 Pin No.
Scan 1 (P90)	PA0	REW KEY	Fast Reverse (⏮) command. L when ON.	1
	PA1	FF KEY	Fast Forward (⏭) command. L when ON.	2
	PA2	PLAY KEY	Play instruction. L when ON.	3
	PA3	REC KEY	Record instruction. L when ON.	4
Scan 2 (P91)	PA0	DIRECTION KEY	Forward/reverse switching instruction. L when ON.	5
	PA1	MUTE/SEARCH KEY	Mute/search instruction. L when ON.	6
	PA2	CASSETTE IN	L when a cassette is present.	7
	PA3	STOP KEY	Stop instruction. L when ON.	8
Scan 3 (P92)	PA0	FWD erasure protection claw.	L when recording is possible.	9
	PA1	REV erasure protection claw.	L when recording is possible.	10
	PA2	70μ detector	H for 70μ tape.	11
	PA3	Metal detector	H for Metal tape.	12
Scan 4 (P93)	PA0	ONE WAY	L when reverse mode is (⇄).	15
	PA1	REVERSE	L when reverse mode is (⇄).	16
	PA2	Mechanism direction SW	L during reverse play.	17
	PA3	Leader tape sensor	L during leader tape section.	18

Chip Select (P82, P83) 01:IC306

Digit	Input Port	Name	Function	LC7800 Pin No.
Scan 1 (P90)	PA0	TIMER PLAY SW	L for starting playback when power goes ON.	1
	PA1	TIMER REC SW	L for starting recording when power goes ON.	2
	PA2	TIMER DUAL REC SW	L for starting recording on both Mechanism 1 and 2 when power goes ON.	3
	PA3	RELAY SW	Relay instruction. L when ON.	4
Scan 2 (P91)	PA0	MODE KEY	Key for dubbing mode selection.	5
	PA1	SPEED KEY	Key for dubbing speed selection.	6
	PA2	START KEY	Dubbing start instruction.	7
	PA3	HEADPHONE SELECT KEY	Key for headphone selection.	8
Scan 3 (P92)	PA0	MECHANISM-1 RESET KEY	Mechanism-1 counter reset instruction.	9
	PA1	MECHANISM-1 TAPE KEY	Key for Mechanism-1 tape length selection.	10
	PA2	MECHANISM-1 REMAIN KEY	Key for counting and display of the remaining time on Mechanism-1.	11
	PA3	SKIP SW	Skip instruction.	12
Scan 4 (P93)	PA0	MECHANISM-2 RESET KEY	Mechanism-2 counter reset instruction.	15
	PA1	MECHANISM-2 TAPE KEY	Key for Mechanism-2 tape length selection.	16
	PA2	MECHANISM-2 REMAIN KEY	Key for counting and display of the remaining time on Mechanism-2.	17
	PA3	NC	—	18

KX-W900/W900U

● **MODE VS OUTPUT**

Note: In Deck-1 modes, terminal outputs 6, 7, 8, 13, 17, 19, 20 and 21 are Selected.
In Deck-2 modes, terminal outputs 10, 11, 12, 14, 25, 27, 28 and 29 are selected.

OUTPUT (Pin No.)		MODE	STOP	FWD PLAY	REC/ PAUSE	REV REC PLAY	▷▷	◁◁	▷▷ SEARCH	◁◁ SEARCH
6,10	Capstan speed		H	L	H	L	H	H	H	H
7,11	Reel motor (+)		H	L	H	H	L	H	L	H
8,12	Reel motor (-)		H	H	H	L	H	L	H	L
13,14	Solenoid hold		H	L	H	L	L	L	L	L
17,25	REC/PLAY		L	L	H	H	L	L	L	L
19,27	LINE mute		H	L	L	L	H	H	H	H
20,28	REC mute		H	H	H	L	H	H	H	H
21,29	REC bias		L	L	L	H	L	L	L	L

OUTPUT (Pin No.)		MODE	STOP	NORMAL SPEED DUBBING	HIGH SPEED DUBBING
16	Dubbing		H	L	L
15	High speed dubbing		H	H	L

Note: L....Low level
H....High level

● **MECHANISM DRIVE**

Construction: 2 motors, 1 solenoid.

Operating system: Can assist mechanism triggered when the solenoid turns ON.

Assist: Capstan motor.

● **Mode change**

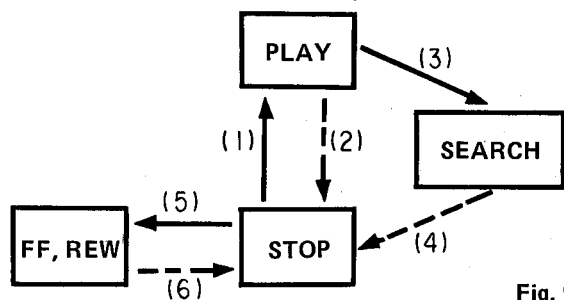

→ Turning the solenoid ON with 1 or 2 pulses, and keeping it ON.
- - - Turning the held solenoid OFF.

Fig. 9

- (1) When the Stop mode solenoid is turned ON with 2 pulses (for FWD) or with 1 pulse (for REV) and the solenoid is then held ON, the mechanism enters Play mode.
- (2) When the solenoid that is held in Play mode is turned OFF, the mechanism enters Stop mode.
- (3) When the Play mode solenoid is turned ON with 1 pulse and is then held ON, the pinch roller is separated from the capstan and the mechanism enters SEARCH mode.
- (4) When the solenoid that is held in REARCH mode is turned OFF, the mechanism returns to Stop mode.
- (5) When the Stop mode solenoid is turned ON with 1 pulse without turning the capstan motor ON and the solenoid is then held ON, the mechanism enters FF/REW mode.
- (6) When the solenoid that is held in FF/REW mode is turned OFF, the mechanism enters Stop mode.

Note: In (1) to (4), the capstan motor is turned ON at the same time as the mode changes.

● **Operation when power is turned ON**

The capstan motor is driven for 1 second in order to assure that the head base falls.

KX-W900/W900U

■ DISPLAY Pin Connection LCD-9476MJ

● LCD UNIT DATA TRANSFER SPECIFICATIONS

- Microprocessor ports P70 D1 Data Output port P72 CE2 Chip Select ports
P71 CL Clock port P73 CE1

● Data transfer formats

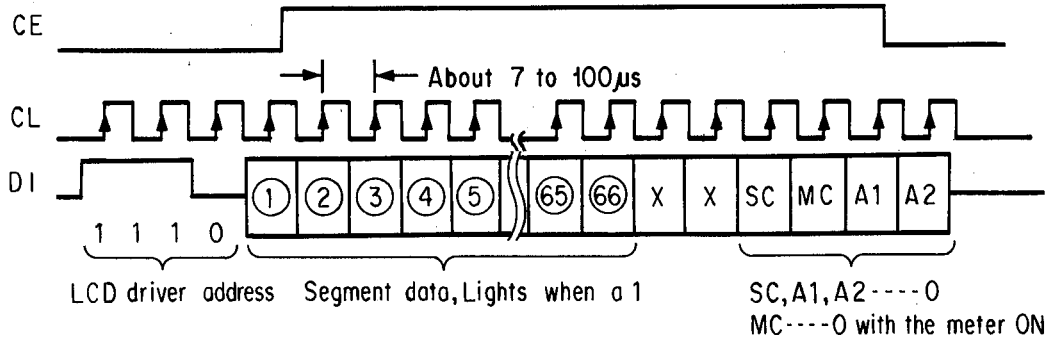

● SEGMENT (1)

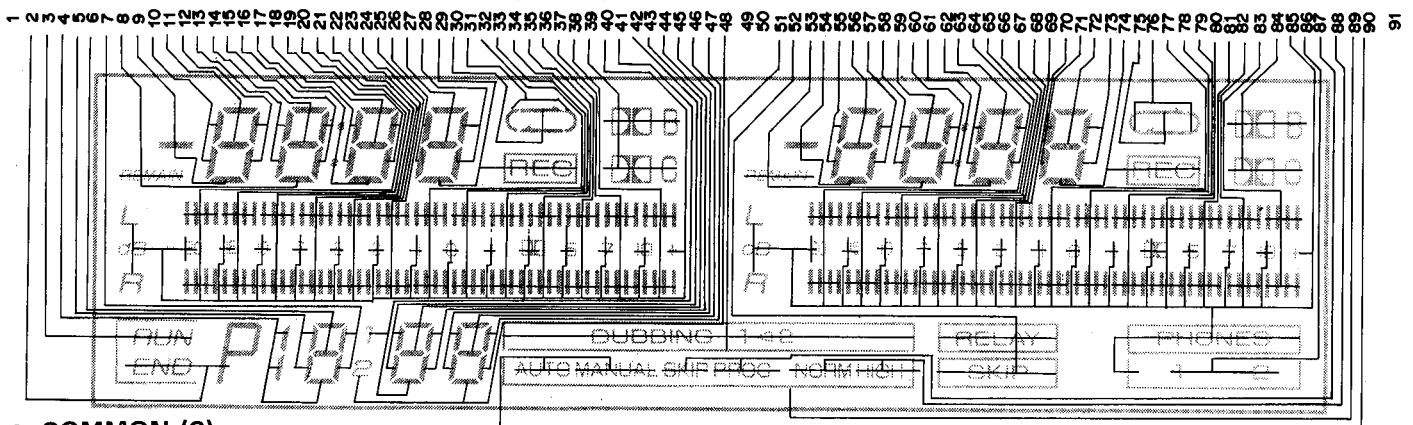

● COMMON (2)

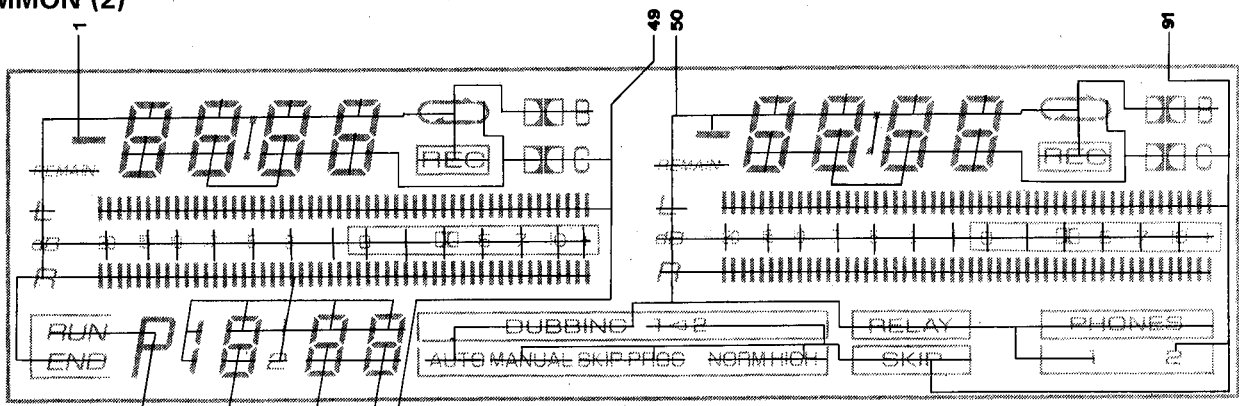

NO.	1	2	3	4	5	6	7	8	9	10	11	12	13	14	15	16	17	18	19	20	21	22	23	24	25
COM1	COM	END	□	K9	10f	10a	10b	REMAIN (1)	□	1f	1a	1b	2f	2a	2b	COL (1)	3f	3a	3b	R1 (1)	R2 (1)	R3 (1)	R4 (1)	R5 (1)	R6 (1)
COM2	—	P	RUN	10d	10e	10g	10c	2d	1d	1e	1g	1c	2e	2g	2c	3d	3e	3g	3c	L1 (1)	L2 (1)	L3 (1)	L4 (1)	L5 (1)	L6 (1)
NO.	26	27	28	29	30	31	32	33	34	35	36	37	38	39	40	41	42	43	44	45	46	47	48	49	
COM1	4f	4c	4b	REC (1)	□	(1)	R7 (1)	R8 (1)	R9 (1)	R10 (1)	R11 (1)	R12 (1)	R13 (1)	□□B (1)	*1	1 (1)	11f	11a	11b	12f	12a	12b	2 (1)	—	
COM2	4e	4g	4c	4d	—	(1)	L7 (1)	L8 (1)	L9 (1)	L10 (1)	L11 (1)	L12 (1)	L13 (1)	□□C (1)	—	11d	11e	11g	11c	12e	12g	12c	12d	COM	
NO.	50	51	52	53	54	55	56	57	58	59	60	61	62	63	64	65	66	67	68	69	70	71	72	73	74
COM3	COM	1)	RELAY	REMAIN (2)	□	5f	5a	5b	6f	6a	6b	COL (2)	7f	7a	7b	R1 (2)	R2 (2)	R3 (2)	R4 (2)	R5 (2)	R6 (2)	8f	8a	8b	REC (2)
COM4	—	1	□	6d	5d	5e	5g	5c	6e	6g	6c	7d	7e	7g	7c	L1 (2)	L2 (2)	L3 (2)	L4 (2)	L5 (2)	L6 (2)	8e	8g	8c	8d
NO.	75	76	77	78	79	80	81	82	83	84	85	86	87	88	89	90	91								
COM3	□	(2)	(2)	R7 (2)	R8 (2)	R9 (2)	R10 (2)	R11 (2)	R12 (2)	R13 (2)	□□B (2)	*2	1 (2)	SKIP	NORM	□	AUTO	—							
COM4	—	(2)	(2)	L7 (2)	L8 (2)	L9 (2)	L10 (2)	L11 (2)	L12 (2)	L13 (2)	□□C (2)	—	2 (2)	PROG.	HIGH	—	MANUAL	COM							

Note: marked 1) DUBBLING
marked *1 All light
marked *2 All light

TIMING CHART

MECHANISM DRIVE TIMING (μ -COM OUTPUT)

(Note) Δt : Delay from KEY input (about 50msec.)

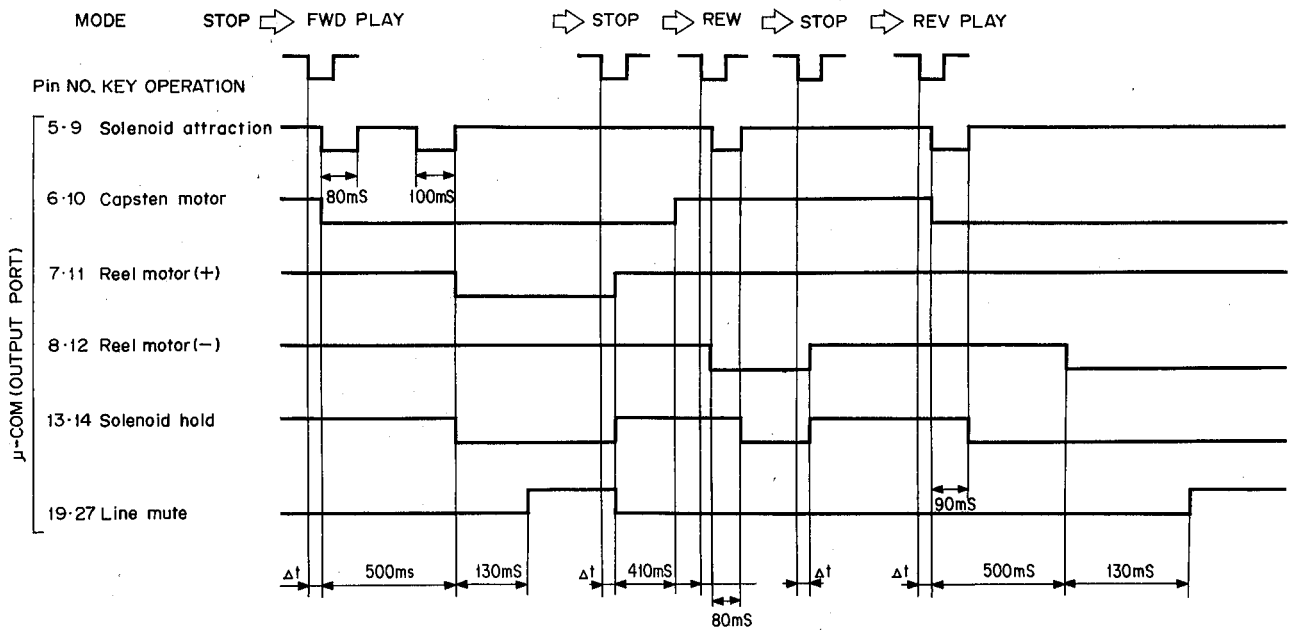

Table 4

MECHANISM DRIVE TIMING (μ -COM OUTPUT)

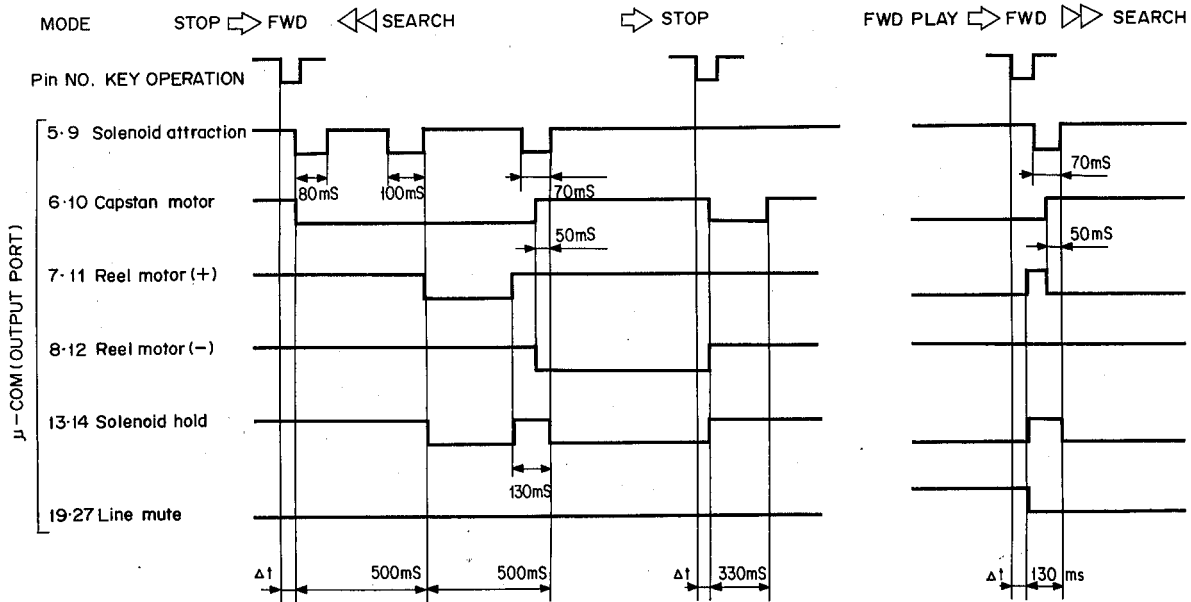

Table 5

KX-W900/W900U

● DUBBING OPERATING TIMING (μ -COM OUTPUT)

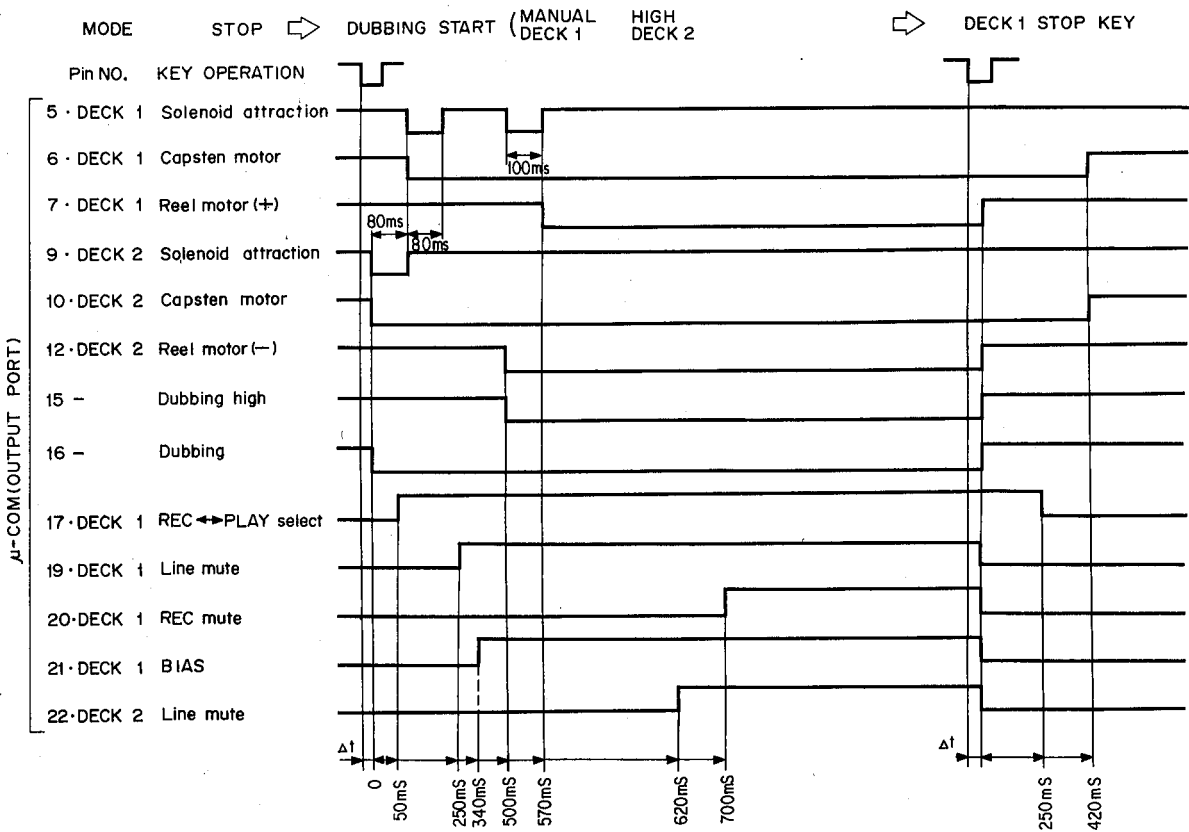

Table 6

● AMP SELECTOR TIMING (μ -COM OUTPUT)

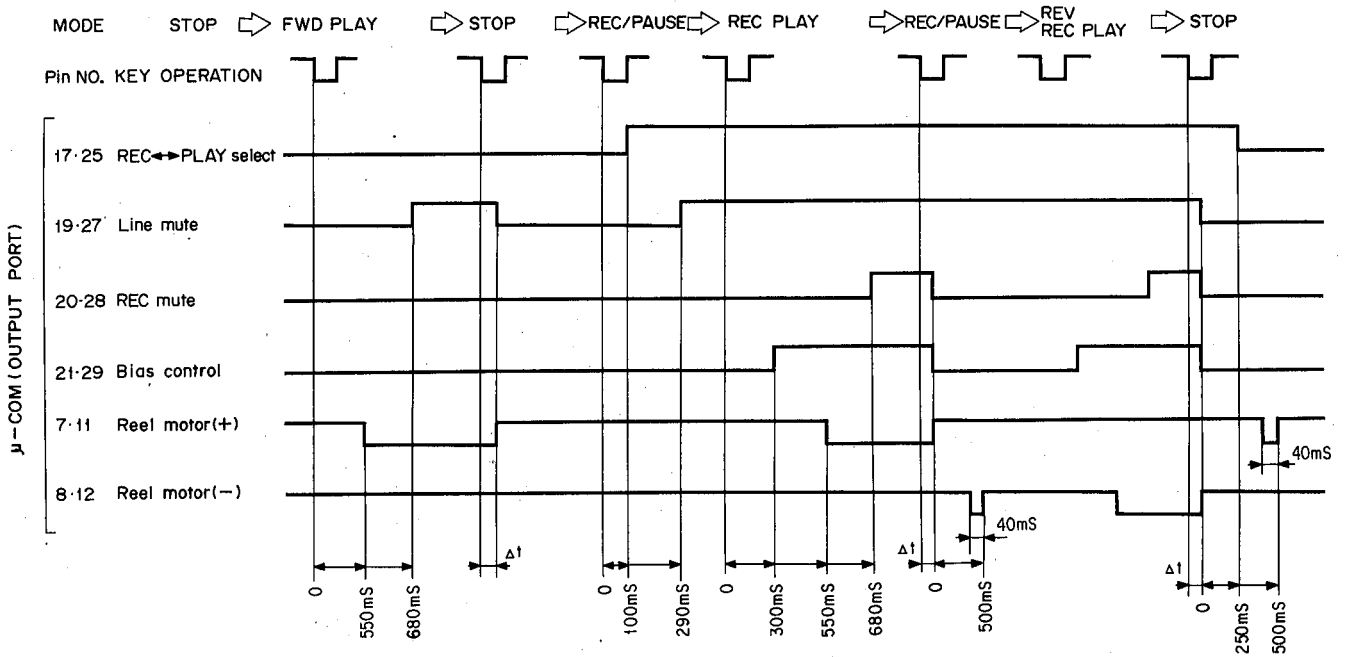
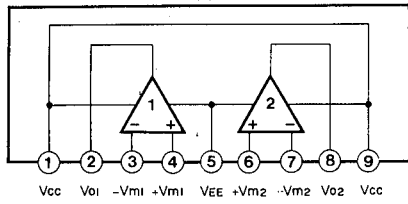

Table 7

KX-W900/W900U

IC BLOCK

IC7, 20, 13, 308, 309, 313, 314:
AN6551, NJM4558S, BA715
NJM4556SA (Dual Ope-amp.)



IC14~16: AN90B20
(Transistor Array)

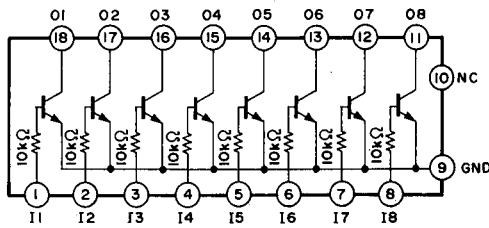

IC301, 303: BA6229
(Motor Turning IC)

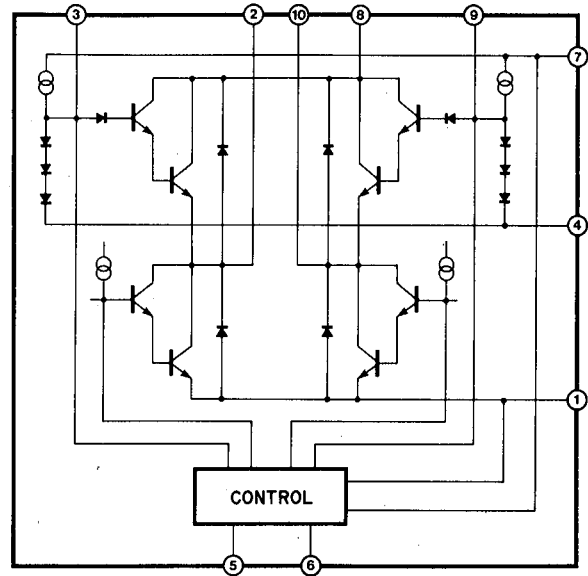

IC311: AN78M05, NJM78M05A
(Regulator)

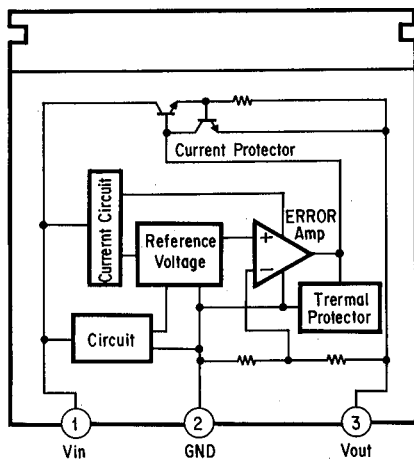

IC1, 2, 17~19: μPD4066BC, LC4066B
M4066BP, MN4066B, BU4066B
(Analog Switch)

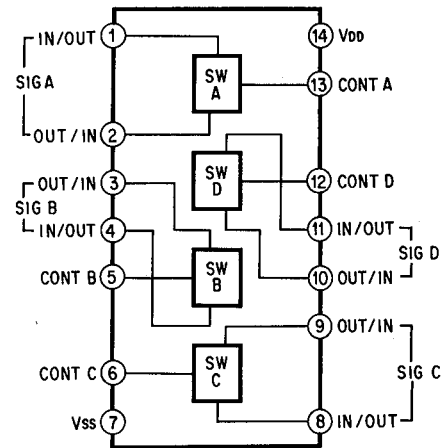

IC310: TC4011P, BU4011B or MN4011B
(Quad 2-Input Positive NAND Gates)

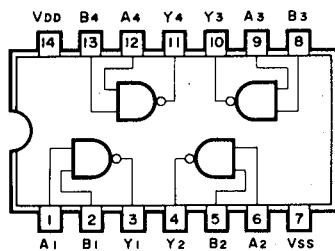

IC3, 9: μ PC1290C
(PB/REC Head Switch IC)

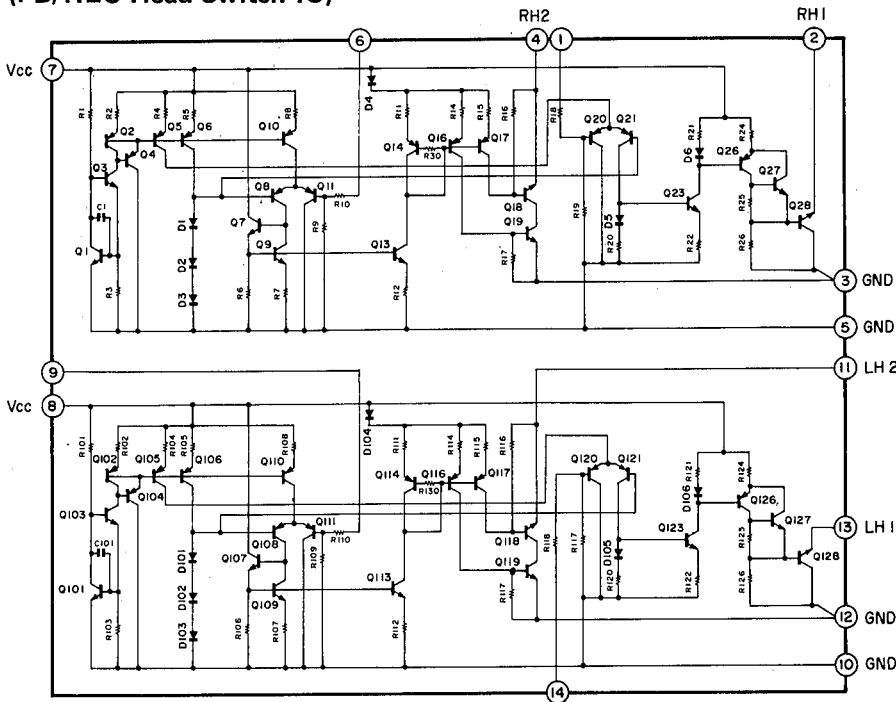

Pin No.	Symbol	Name	Pin No.	Symbol	Name
1	INR1	REC SW control	8	VCC2	+5V
2	SWR1	REC SW	9	INP2	PB SW control
3	GND	GND	10	GND	GND
4	SWP1	PB SW	11	SWP2	PB SW
5	GND	GND	12	GND	GND
6	INP1	PB SW control	13	SWR2	REC SW
7	VCC1	+5V	14	INR2	REC SW control

IC5, 11: CX20187
(Dolby NR)

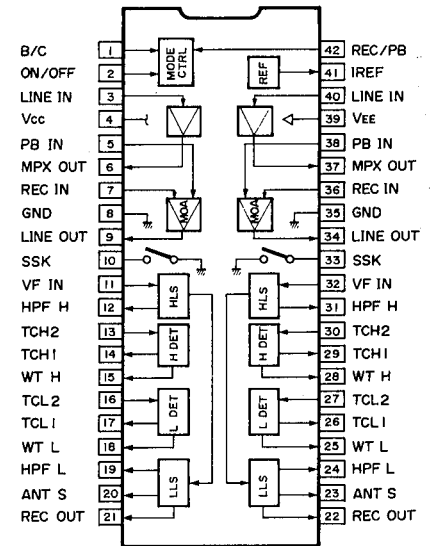

IC8: VD94800
(Bias OSC Block)

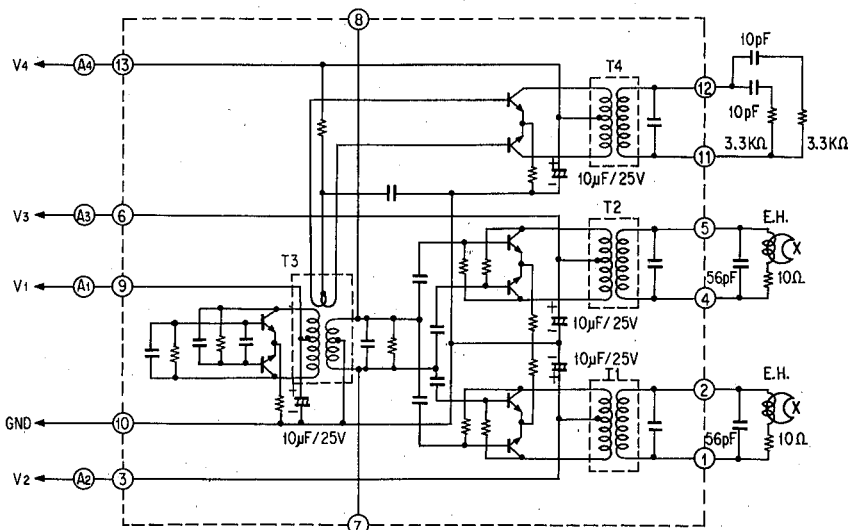

IC302: M54567
(4 Unit L'Active Type Transistor Array with Clamp Diode)

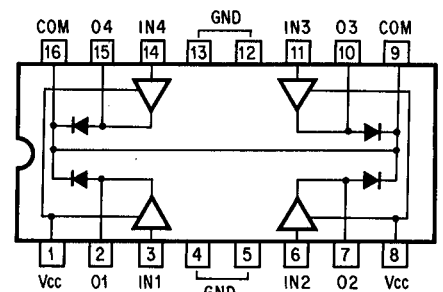

WIRING

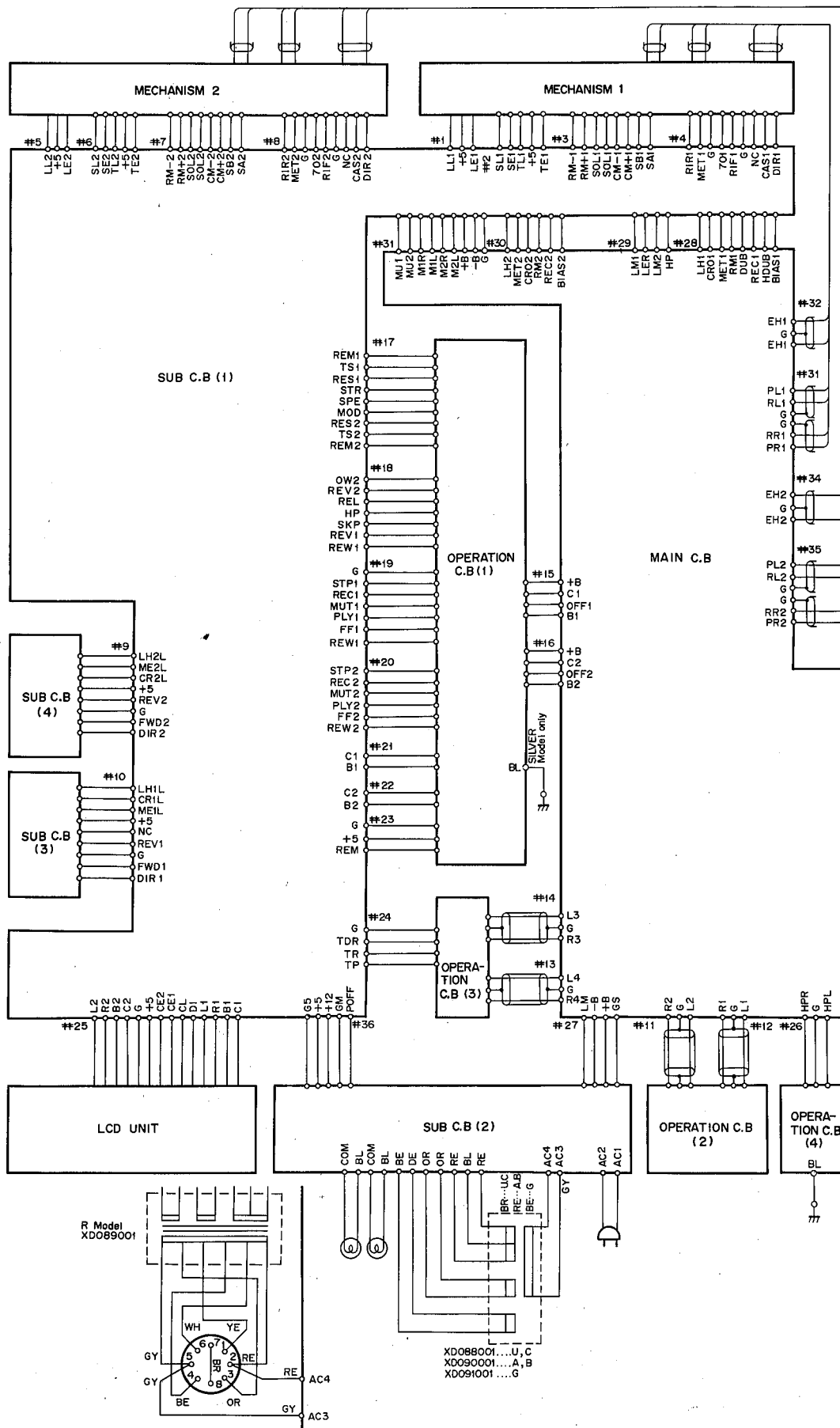

KX-W900/W900U

■ BLOCK DIAGRAM

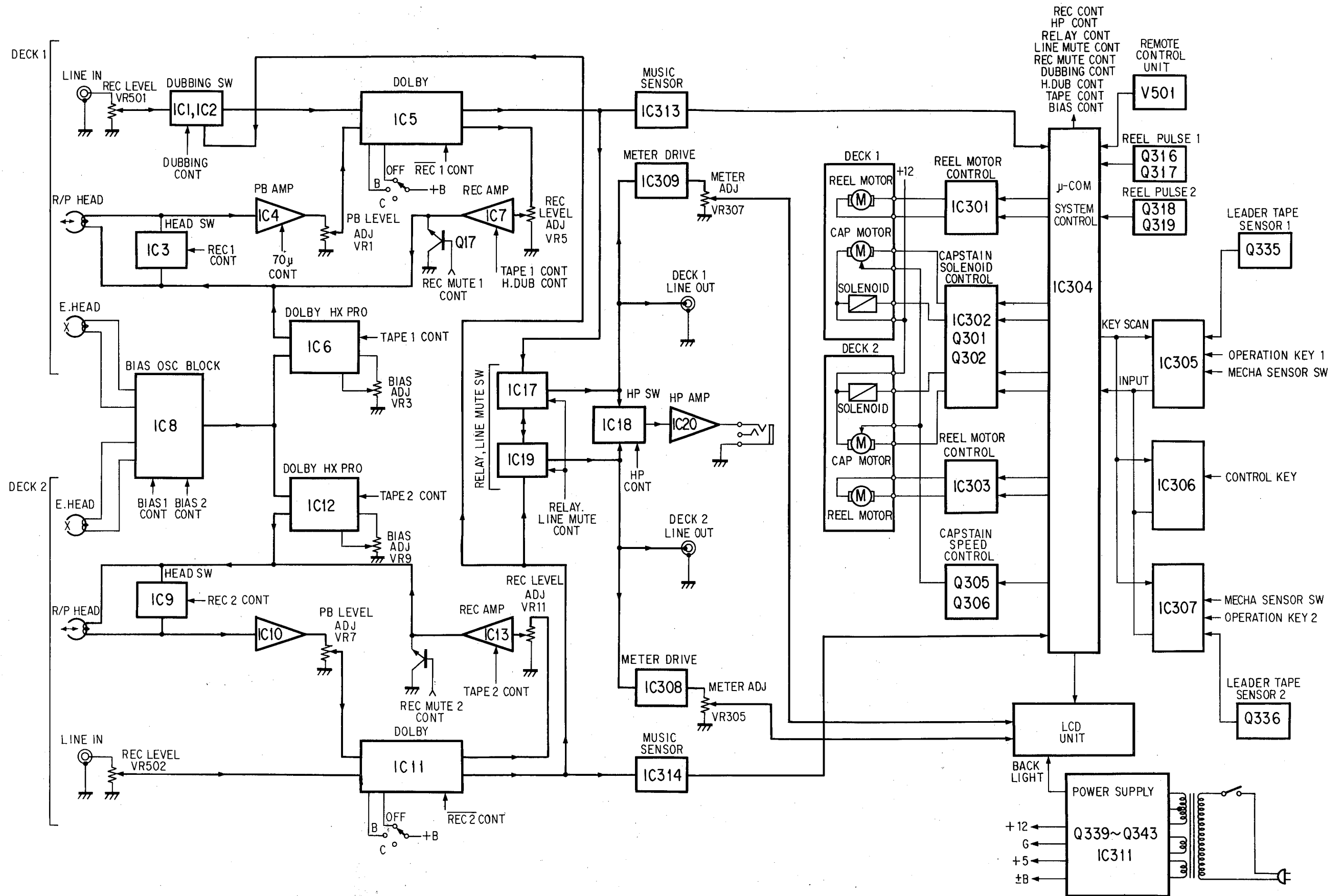

A

B

C

D

E

F

G

H

I

KX-W900/W900U

PRINTED CIRCUIT BOARD (Pattern Side)

(Note) 文字面 : Component Side

1

2

3

4

5

6

7

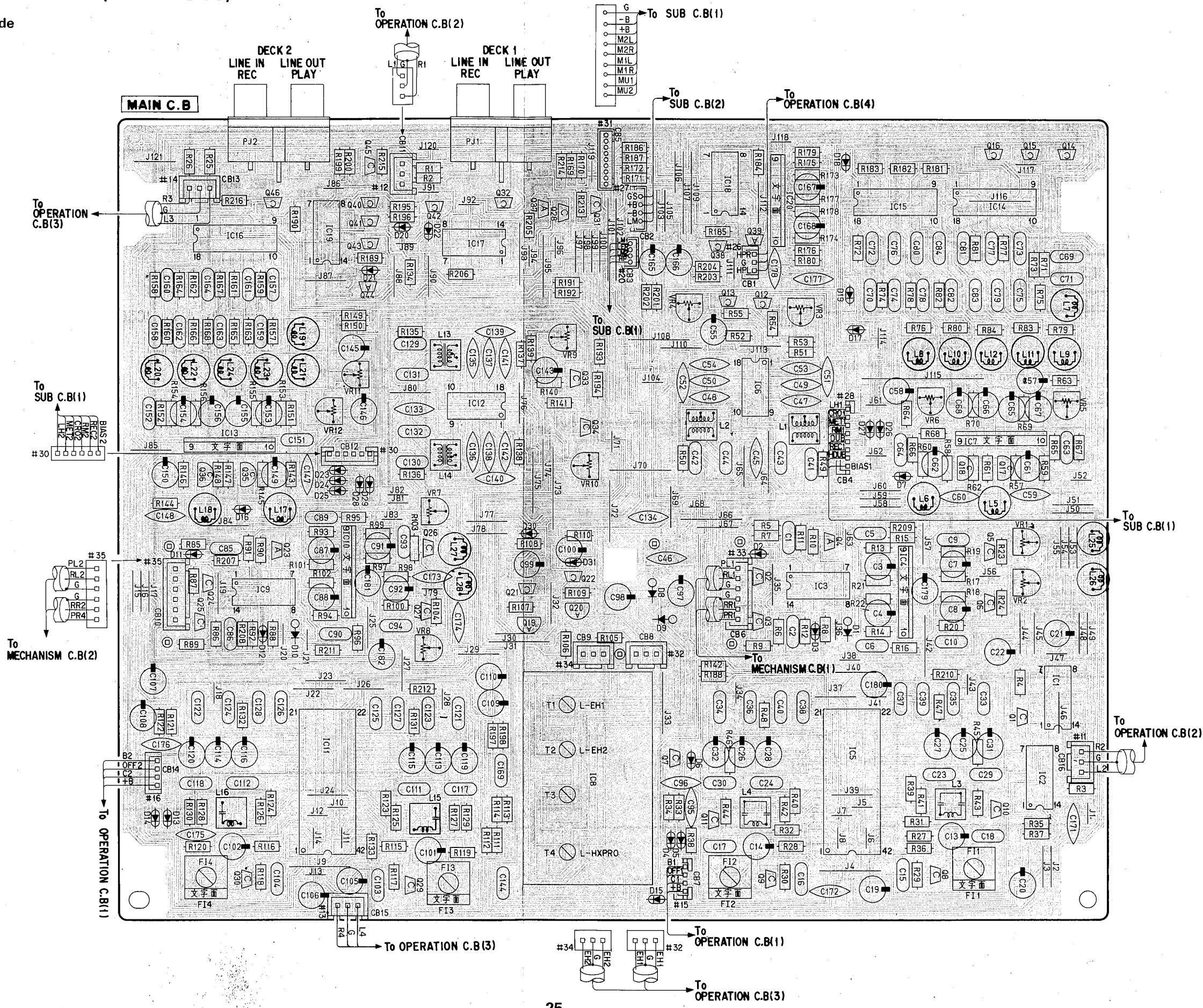

PRINTED CIRCUIT BOARD (Pattern Side) (Note) 文字面 : Component Side

1
2
3
4
5
6
7

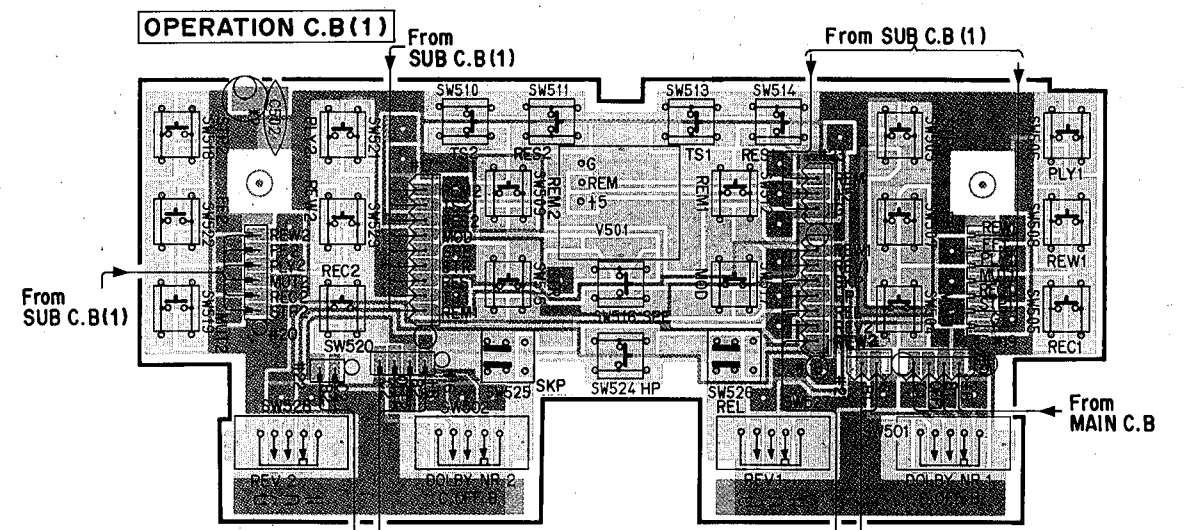
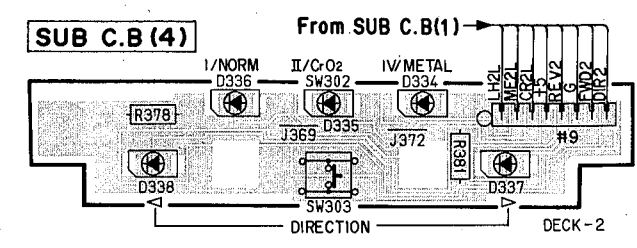
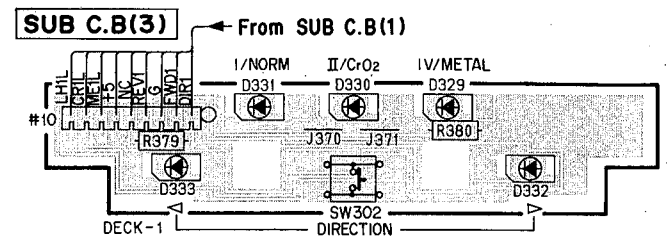

Note : * marked

Black	Silver
2 C502	OPEN 0.01

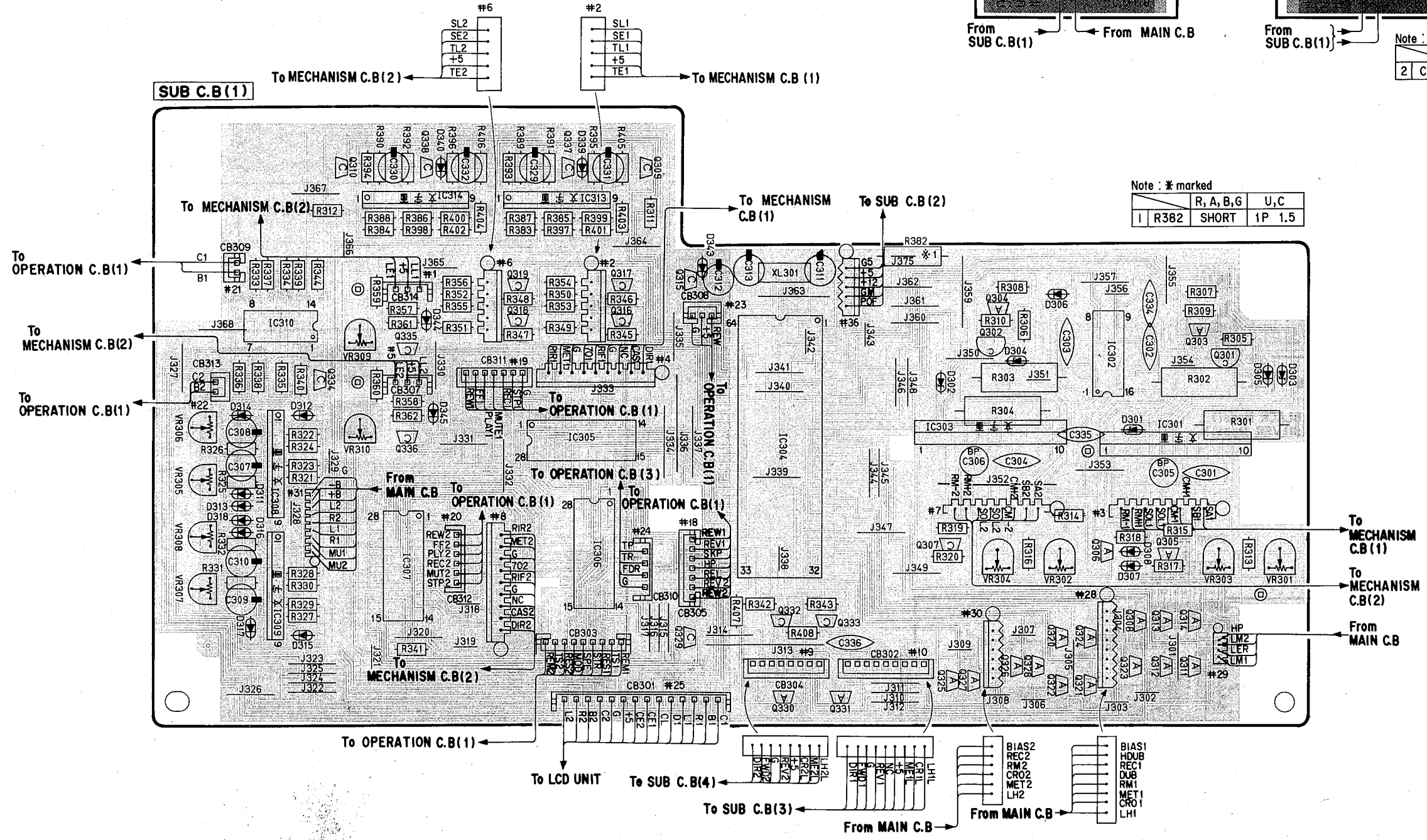

Note : * marked

R, A, B, G	U, C
I R382	SHORT 1P 1.5

KX-W900/W900U

A

B

C

D

E

F

G

H

I

KX-W900/W900U

PRINTED CIRCUIT BOARD (Pattern Side) (Note) 文字面 : Component Side

1

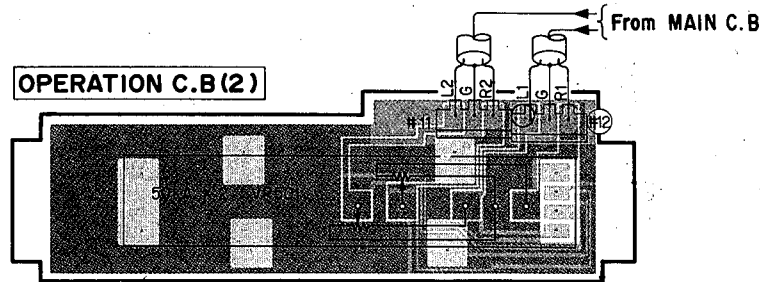

2

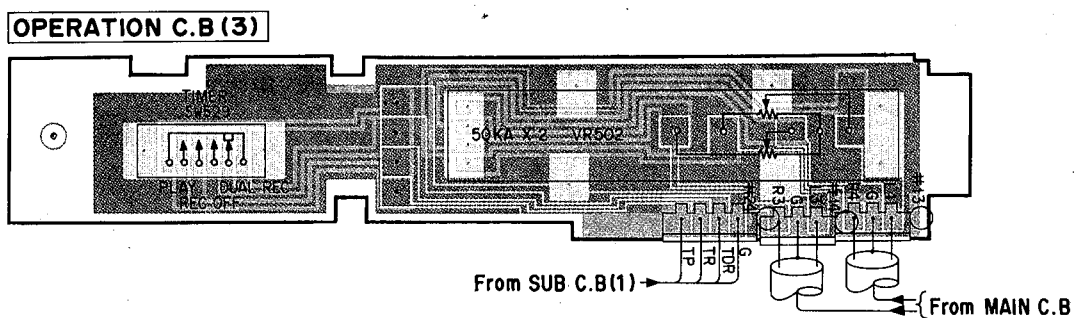

3

4

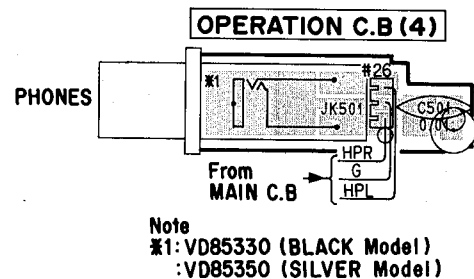

5

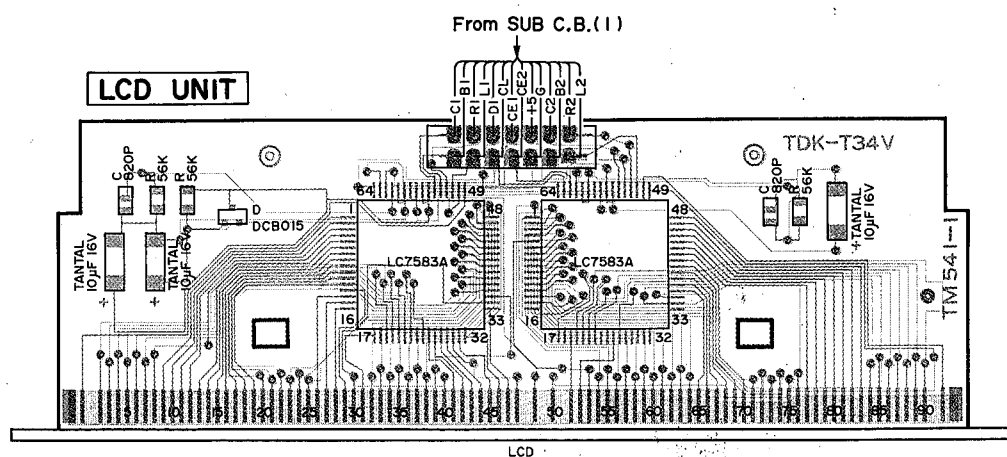

6

7

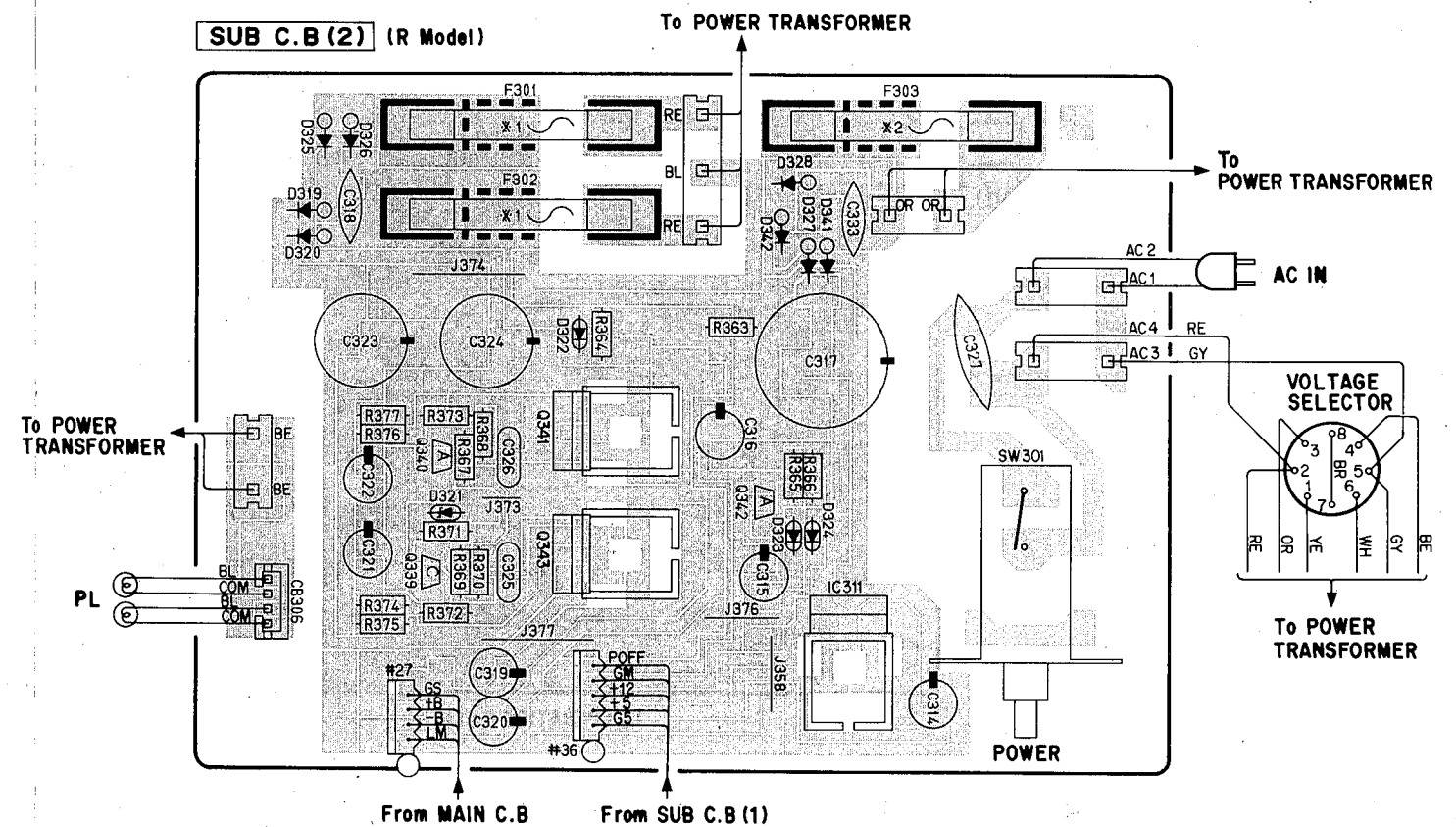
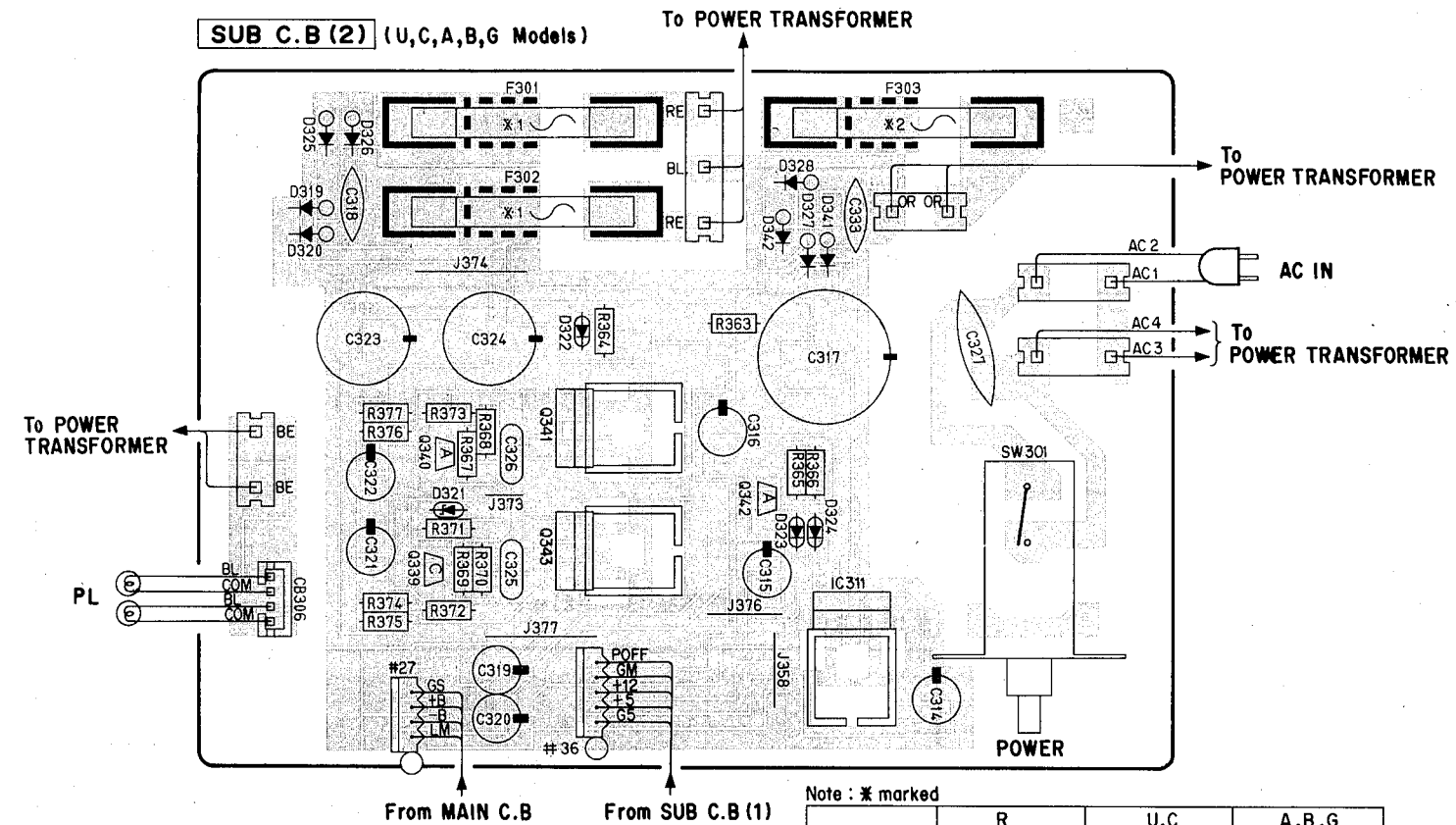

SCHEMATIC DIAGRAM

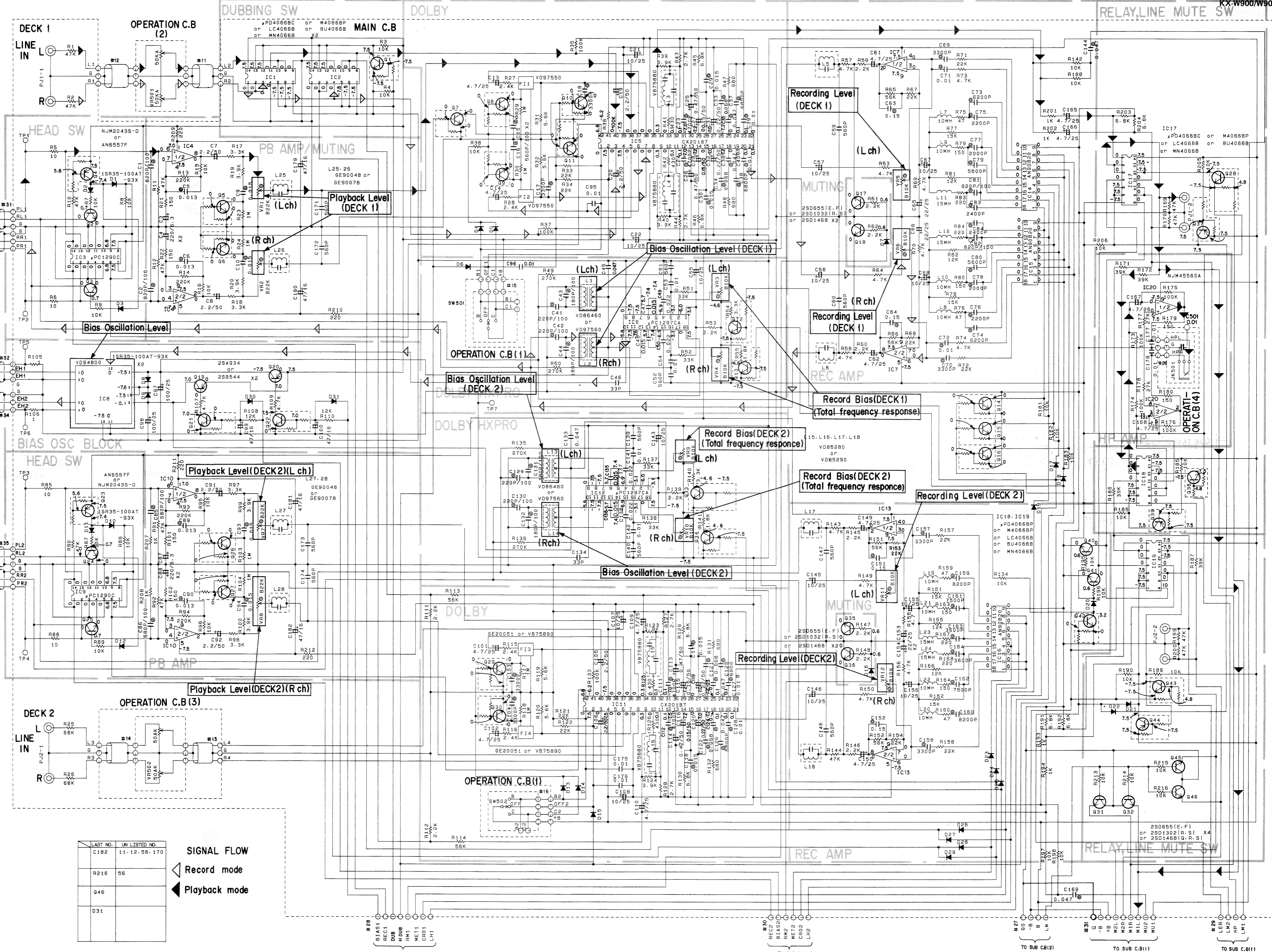

SIGNAL FLOW

◀ Record mode

◀ Playback mode

LAST NO.	UN LISTED NO.
C182	11, 12, 56, 170
R216	56
Q46	
D31	

2SA934	2SC2060	2SA933S (Q,R)	2SB786	1SS133	AN6551	NJM4556SA	PC1290C	BU4011B	CX20187	PC1297CA	MN1756-YAA-2	LC7800	AN78M05	BA6229	AN9020	M54567	LC7583
2SB544	2SD400	2SA1115 (E,F)	2SD947	1SR35-100-AT	AN6557F	NJM4558S	LC4066BC	MN4011B					NJM78M05A				
2SC1740S (S,R)		2SA1310 (R,S,T)		MT24.7A		NJM2043S-D	M4066B										
2SC2603 (E,F)		DTA1146S		MT25.1B		BA715	MN4066B										
2SC3312 (R,S,T)		DTC114ES		MT28.2A			MN4066B										
2SD655 (E,F)							BU4066B										
2SD1302 (R,S)							TC4011P										
2SD1468 (Q,R,S)																	

* All voltages are measured with a 10MΩ/DC electric volt meter.
 * Components having special characteristics are marked with a triangle and must be replaced with parts having specifications equal to those originally installed.
 * Schematic diagram is subject to change without notice.

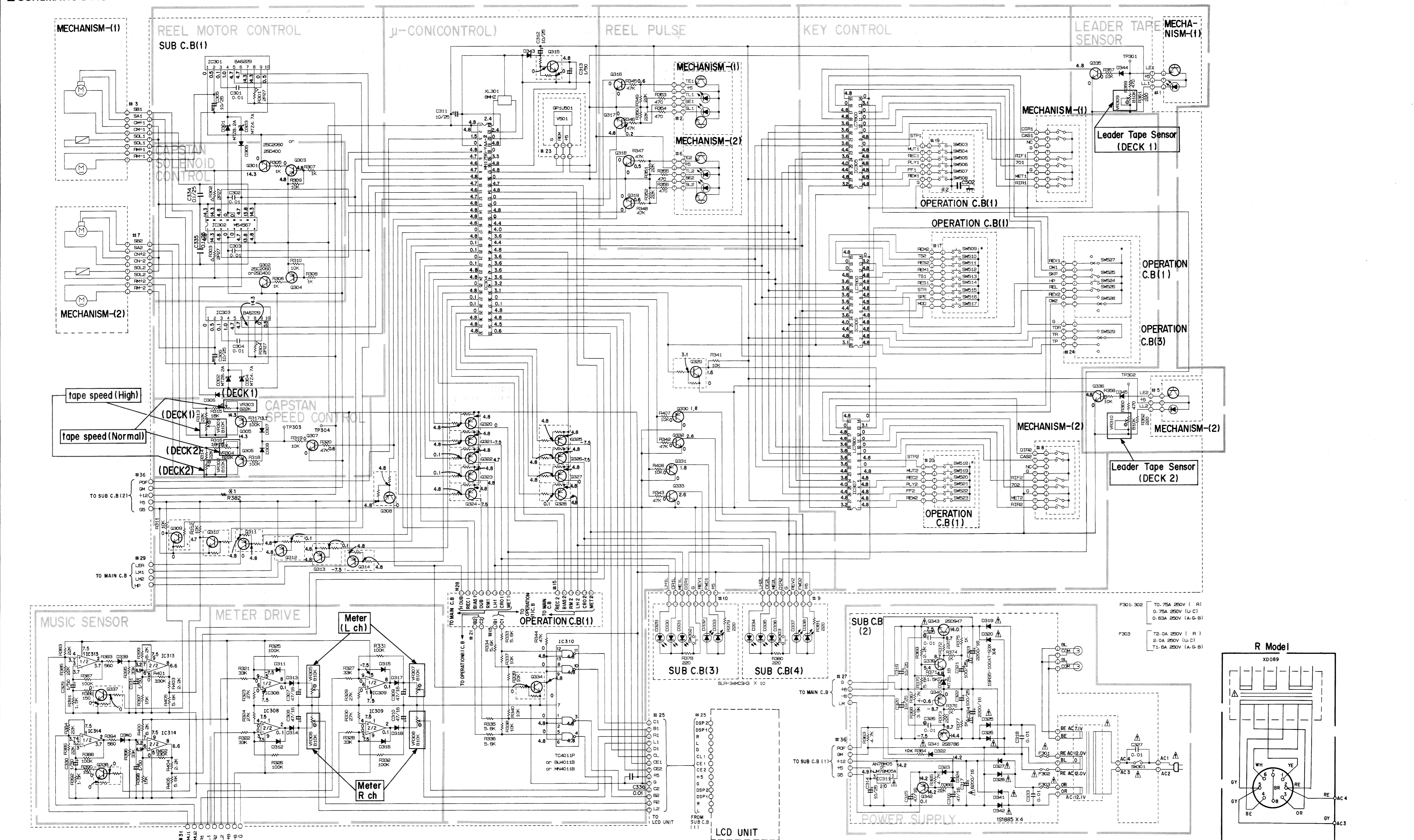

×1 R382	R, A, B, G	U, C	BLACK	SILVER
	SHORT	1P 1.5	×2 C502	OPEN

Unless otherwise specified

PNP TRANSISTOR	2SC1740S (S-R) or 2SC2603 (E-F) or 2SC3312 (R-S-T)
NPN TRANSISTOR	2SA933S (G-R) or 2SA1115 (E-F) or 2SA1310 (R-S-T)
DIODE	1SS133
PNP DIGITRA	DTA114ES
NPN DIGITRA	DTA114ES
IC	AN6551 or NJM4558S or BA715

REMARKS	PARTS NAME
NO MARK	ELECTROLYTIC CAPACITOR
NO MARK	CERAMIC CAPACITOR
○	POLYESTER FILM CAPACITOR
⊙	POLYSTYRENE FILM CAPACITOR
⊖	MICA CAPACITOR
⊕	POLYPROPYLENE FILM CAPACITOR
●	SEMICONDUCTIVE CERAMIC CAPACITOR

REMARKS	PARTS NAME
NO MARK	CARBON FILM RESISTOR
□	CARBON FILM RESISTOR (1/6W)
△	METAL OXIDE FILM RESISTOR
▲	METAL FILM RESISTOR
⊖	METAL PLATE RESISTOR
⊕	FILM PROOF CARBON FILM RESISTOR
■	CEMENT MOLDED RESISTOR
⊗	SEMI VARIABLE RESISTOR

NOTICE
 (U)..... U.S.A. model
 (C)..... Canadian model
 (A)..... Australian model
 (E)..... European model
 (B)..... British model
 (R)..... General model

* All voltages are measured with a 10MΩ DC electric volt meter.
 * Components having special characteristics are marked with a triangle and must be replaced with parts having specifications equal to those originally installed.
 * Schematic diagram is subject to change without notice.

■ SCHEMATIC DIAGRAM

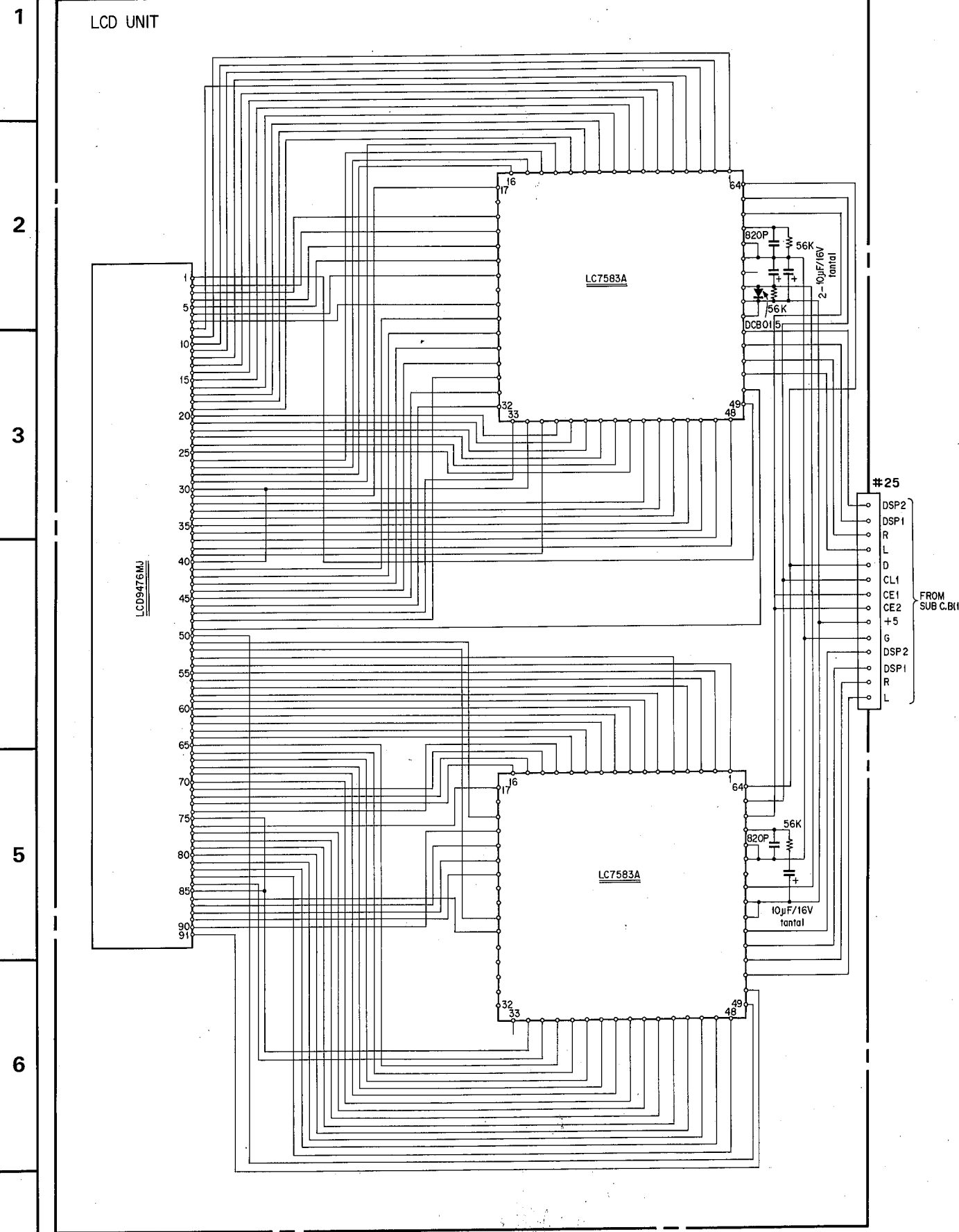

* Schematic diagram is subject to change without notice.

■ PARTS LIST
■ ELECTRICAL PARTS

■ WARNING

Components having special characteristics are marked Δ and must be replaced with parts having specifications equal to those originally installed. Carbon resistors 1/6 W are not included in the ELECTRICAL PARTS list. For the parts No. of the carbon resistor, refer to P. 48

Ref. No.	Part No.	Description	部品名	Remarks	Common Model	Markets	ランク
※	NA 09 53 80	Main Circuit Board	メインシート				
	FG 21 13 30	Ceramic Cap.	セラコン	C46, 134			
	FG 21 25 60	//	//	C51, 52, 59, 60, 139, 140, 147, 148, 171~174			
	FG 24 41 00	//	//	C53, 54, 95, 96, 141, 142, 175~178			
	FG 24 42 20	//	//	C49, 50, 137, 138			
	FG 24 41 50	//	//	C47, 48, 135, 136			
	FG 24 44 70	//	//	C45, 133			
	FA 15 32 00	Mylar Cap.	マイラーコン	C77, 78			
	FA 15 32 20	//	//	C75, 76			
	FA 15 32 40	//	//	C83, 84			
	FA 15 33 30	//	//	C17, 18, 69, 70, 103, 104, 157, 158			
	FA 15 33 60	//	//	C163, 164			
	FA 15 34 70	//	//	C23, 24, 111, 112			
	FA 15 35 60	//	//	C79, 80			
	FA 15 36 20	//	//	C73, 74			
	FA 15 36 80	//	//	C37, 38, 125, 126			
	FA 15 37 50	//	//	C161, 162			
	FA 15 38 20	//	//	C159, 160			
	FA 15 41 00	//	//	C39, 40, 71, 72, 127, 128			
	FA 15 41 30	//	//	C5, 6, 89, 90			
	FA 15 41 50	//	//	C9, 10, 29, 30, 93, 94, 117, 118			
	FA 15 44 70	//	//	C35, 36, 123, 124, 144, 169			
	FA 15 46 80	//	//	C33, 34, 121, 122			
	FA 15 51 50	//	//	C63, 64, 151, 152			
	UJ 11 82 20	Electrolytic Cap.	ケミコン	C3, 4, 87, 88			
	UJ 13 74 70	//	//	C99, 100, 179~182			
	UH 14 64 70	//	//	C13, 14, 61, 62, 101, 102, 109, 110, 149, 150, 165~168			
	UH 14 71 00	//	//	C21, 22, 55, 57, 58, 67, 68, 107, 108, 143, 145, 146, 155, 156			
	UH 14 72 20	//	//	C65, 66, 153, 154			
	UH 14 81 00	//	//	C97, 98			
	UH 16 54 70	//	//	C25, 26, 113, 114			
	UH 16 62 20	//	//	C7, 8, 19, 20, 91, 92, 105, 106			
	UW 56 51 50	//	//	C27, 28, 115, 116			
	UJ 16 52 20	//	//	C31, 32, 119, 120			
	UT 45 21 80	Polypropylene Film Cap.	ポリプロコン	C43, 44, 131, 132			
	UT 45 25 60	//	//	C15, 16			
	UT 45 22 20	//	//	C41, 42, 129, 130			
	UT 45 26 80	//	//	C85, 86			
	UT 45 28 20	//	//	C1, 2, 81, 82			
※	VD 97 55 00	MPX Filter	倍速用MPXフィルター	Fil, 2			
	GE 20 05 10	Dolby Filter	ドルビーフィルター	F3, 4	Inter-changeable		
	VB 75 89 00	MPX Coil	MPX コイル	//			
	GE 90 04 80	Bias Trap Coil	バイアストラップコイル	L25~28	Inter-changeable		
	GE 90 07 80	//	//	//			
※	VD 85 28 00	//	//	L5, 6, 17, 18			
	VB 75 88 00	Skewing Coil	スキューイングコイル	L3, 4, 15, 16			
	GE 90 16 30	Coil	固定コイル	L7~10, 19~22			
	GE 90 16 50	//	//	L11, 12, 23, 24			
※	VD 86 46 00	Step-up Coil	ステップアップコイル	L1, 2, 13, 14			
	VB 86 15 00	Pre-set Potentiometer	半固定抵抗	VR3~6, 9~12			
	VB 86 16 00	//	//	VRI, 2, 7, 8			

※ New Parts (新規部品)

KX-W900/W900U

Ref. No.	Part No.	Description	部品名	Remarks	Common Model	Markets	ランク
	iA 09 34 00	Transistor	2SA934	トランジスタ	Q19,20		
	iB 05 44 10	//	2SB544	//	//		
	iC 17 40 20	//	2SC1740S(R,S)	//	Q2,3,24,25,40,41		
	iC 26 03 10	//	2SC2603(E,F)	//	//		
	iX 60 31 80	//	2SC3312(R,S,T)	//	//		
	iD 06 55 10	//	2SD655(E,F)	//	Q17,18,31,32,33,36,45,46		
	iD 13 02 00	//	2SD1302(R,S)	//	//		
	VA 71 00 00	//	2SD1468(Q,R,S)	//	//		
※	VD 67 85 00	Digital Transistor	DTA114ES	デジタルトランジスタ	Q4,23,37,39,44		
※	VD 67 87 00	//	DTC114ES	//	Q1,5~16,21,22,26~30,33,34,38,42,43		
	iF 00 34 50	Diode	ISS133	ダイオード	D2~7,11~31		
	iF 00 84 80	//	ISR35-100AT	//	D1,8~10		
	iG 08 99 00	Transistor Array	AN90B20	トランジスタアレー	IC14~16		
	iG 03 47 00	IC	AN6551	I C	IC7,13		
	iG 07 68 00	//	NJM4558S	//	//		
	iG 13 22 00	//	BA715	//	//		
	iG 07 74 10	//	NJM4556SA	//	IC20		
	iG 08 29 00	//	NJM2043S-D	//	IC4,10		
※	XD 08 30 01	//	AN6557F	//	//		
	iG 06 16 00	//	μPD4066BC	//	IC1,2,17~19		
	iG 08 92 00	//	LC4066B	//	//		
	iG 11 05 00	//	M4066BP	//	//		
※	XD 08 40 01	//	MN4066B	//	//		
※	XD 14 80 01	//	BU4066B	//	//		
	XB 29 80 01	//	CX20187	//	IC5,11		
	XA 50 80 01	//	μPC1290C	//	IC3,9		
	XA 30 00 01	//	μPC1297CA	//	IC6,12		
※	VD 94 80 00	Bias Oscillator Block	105kHz+210kHz	バイアスOSCブロック	IC8		
	LB 40 10 50	Pin Jack	4P	ピンジャック	PJ1,2		
	LB 91 80 30	Base Pin	3P i-Type	XH ベースピン	CB8		
	LB 91 80 60	//	6P i-Type	//	CB6		
	VC 25 40 00	// (Yellow)	3P i-Type	//	CB9		
※	VC 25 43 00	// (//)	6P i-Type	//	CB10		
	VC 25 25 00	// (Red)	3P i-Type	//	CB11,16		
※	VC 25 55 00	// (Blue)	3P i-Type	//	CB13,15		
	LB 94 50 40	Short Plug	4P	ショートプラグ	CB2		
	VD 00 47 00	Base Pin	4P i-Type	PH ベースピン	CB7		
	VD 00 49 00	//	6P i-Type	//	CB12		
	VD 00 51 00	//	8P i-Type	//	CB4		
	LB 94 20 30	Pin Block	3P i-Type	ピンブロック	CB1		
	LB 94 20 40	//	4P i-Type	//	CB14		
※	VD 61 00 00	Base Pin	4P	ベースピン	CB3		
※	VD 61 05 00	//	9P	//	CB5		
	LA 00 41 20	Test Point Pin		テストポイントピン			

※ New Parts (新規部品)

KX-W900/W900U

Ref. No.	Part No.	Description	部品名	Remarks	Common Model	Markets	ランク
※	NA 09 54 00	Sub Circuit Board		サブシート		U,C	
※	NA 09 54 10	//		//		R	
※	NA 09 54 20	//		//		A,B,G	
	FG 24 41 00	Ceramic Cap.	0.01μF 50V	セラコン	C301~304,318,333,336		
	VA 89 08 00	//	0.01μF 400V	//	C327		△
	Fi 41 41 00	//	0.01μF VA-1	//	//		△
	Fi 51 41 00	//	0.01μF DNS	//	//		△
	FZ 00 41 30	Semiconductive Ceramic Cap.	0.1μF 25V	半導体セラコン	C334,335		
	FA 15 41 00	Mylar Cap.	0.01μF 50V	マイラーコン	C325,326		
	UJ 13 74 70	Electrolytic Cap.	47μF 16V	ケミコン	C307~310,315,316		
	UH 14 71 00	//	10μF 25V	//	C311,312,314,319,320		
	UH 14 81 00	//	100μF 25V	//	C321,322		
	UH 16 61 00	//	1μF 50V	//	C313,329~332		
	Ui 93 98 20	//	8200μF 16V	//	C317		△
	UH 13 92 20	//	2200μF 16V	//	C323,324		△
	UK 34 71 00	//	10μF 25V	BP コン	C305,306		
※	VD 79 43 00	Ceramic Oscillator	8MHz	セラミック振動子	XL301		
	HL 32 42 70	Metal Oxide Film Resistor	27Ω 2W	酸金抵抗	R301~304		
	HL 31 31 50	//	1.5Ω 1W	//	R382	U,C	
	VB 86 15 00	Pre-set Potentiometer	B 10kΩ	半固定抵抗	VR301,302,305~310		
	VB 86 16 00	//	B 22kΩ	//	VR303,304		
	iA 09 33 00	Transistor	2SA933S(Q,R)	トランジスタ	Q303~306,330,331,340,342		
	iA 11 15 10	//	2SA1115(E,F)	//	//		
	iX 60 31 70	//	2SA1310(R,S,T)	//	//		
	iC 20 60 00	//	2SC2060	//	Q301,302		
	iD 04 00 10	//	2SD400	//	//		
	iC 17 40 00	//	2SC1740S(R,S)	//	Q307,316~319,332,333,335,336,339		
	iC 26 03 10	//	2SC2603(E,F)	//	//		
	iX 60 31 80	//	2SC3312(R,S,T)	//	//		
	iB 07 86 00	//	2SB786	//	Q341		△
	iD 09 47 00	//	2SD947	//	Q343		△
※	VD 67 85 00	Digital Transistor	DTA114ES	デジタルトランジスタ	Q308,311~314,320~328		
※	VD 67 87 00	//	DTC114ES	//	Q309,310,315,329,334,337,338		
	iF 00 34 50	Diode	ISS133	ダイオード	D305~308,311~318,322~324,339,340,343~345		
	iF 00 84 80	//	ISR35-100AT	//	D319,320,325,326		
	iH 00 02 40	//	ISI885	//	D327,328,341,342		
	iF 01 06 50	Zener Diode	MTZ4.7A	ツェナーダイオード	D303,304		
	iF 01 06 90	//	MTZ5.1B	//	D321		
	iF 01 08 20	//	MTZ8.2A	//	D301,302		
	iF 00 87 40	LED	SLR-34MC3H3	L E D	D329~338		
	iG 15 25 00	IC	BA6229	I C	IC301,303		
	iG 12 65 00	//	M54567	//	IC302		
	iG 03 47 00	//	AN6551	//	IC308,309,313,314		
	iG 07 68 00	//	NJM4558S	//	//		
	iG 13 22 00	//	BA715	//	//		
	iG 07 56 00	//	NJM78M05A	//	IC311		△

※ New Parts (新規部品)

Ref. No.	Part No.	Description	部品名	Remarks	Common Model	Markets	ランク
	IG 14 63 00	IC	LC7800	I C	IC305~307		
	IG 00 12 40	//	TC4011P	//	IC310		
※	XD 14 90 00	//	MNI756-YAA-2	//	IC304		
	VC 13 31 00	Switch, Power	SDDLDI	パワースイッチ	SW301		△
	KA 90 63 50	Switch	KHH1092	タクトスイッチ	SW302,303	} Inter-changeable	
	KA 90 63 80	//	5MEVQ-QRB-04M	タッチスイッチ	//		
	KB 00 03 50	Fuse	T2.0A 250V	ヒューズタイラッシュ	F303	R	△
	KB 00 12 40	// UL ST-4	2.0A 250V	ヒューズ	//	U,C	△
	KB 00 07 40	//	T1.6A 250V	ヒューズタイムラグ	//	A,B,G	△
	KB 00 03 20	//	T0.75A 250V	ヒューズタイラッシュ	F301,302	R	△
	KB 00 12 20	// UL ST-4	0.75A 250V	ヒューズ	//	U,C	△
	KB 00 06 70	//	0.63A 250V	ヒューズタイムラグ	//	A,B,G	△
※	VC 01 47 00	Base Pin	3P i-Type	EH ベースピン	CB314		
※	VD 90 04 00	// (Yellow)	3P i-Type	//	CB307		
※	VC 01 58 00	//	14P i-Type	//	CB301		
	LB 94 20 20	Pin Block	2P i-Type	ピンブロック	CB313		
	LB 94 20 70	//	7P i-Type	//	CB311		
	LB 94 20 60	//	6P i-Type	//	CB312		
	VD 00 45 00	Base Pin	2P i-Type	PH ベースピン	CB309		
	VD 00 46 00	//	3P i-Type	//	CB308		
	VD 00 47 00	//	4P i-Type	//	CB306		
	VD 00 50 00	//	7P i-Type	//	CB305		
	VD 00 52 00	//	9P i-Type	//	CB303		
	LB 94 20 80	Pin Block	8P i-Type	ピンブロック	CB304		
	LB 94 20 90	//	9P i-Type	//	CB302		
	VD 65 05 00	Base Pin	4P i-Type	EH ベースピン	CB310		
	LB 94 50 50	Short Plug	5P i-Type	ショートプラグ	CB315		
※	VD 85 10 00	Sub Connector Ass'y		サブコネクタ Ass'y			
	LA 00 41 20	Test Point pin		テストポイントピン			
	LB 20 18 80	Fuse Holder Pin	PC-FHI	ヒューズホルダーピン			
	LA 00 21 40	Lapping Terminal	P=10 2P i-Type	i型ラッピング端子板			
	LA 00 20 00	//	P=7.5 2P i-Type	//			
	LA 00 23 20	//	P=7.5 3P i-Type	//			
	BA 08 40 00	Heat Sink		放熱板			
	Ei 03 00 66	Binding Head Tapping Screw	3×6 ZMC2-Y	バインドタッピングネジ	PACK		
※	NA 09 54 70	Operation Circuit Board		オペレーションシート	Black		
※	NA 09 60 70	//		//	Silver		
※	VD 82 79 00	Potentiometer	A 50kΩ×2	スライドボリューム	VR501,502		
	KA 90 63 50	Switch	KHH1092	タクトスイッチ	SW503~524	} Inter-changeable	
	KA 90 63 80	//	5MEVQ-QRB-04M	ライトタッチスイッチ	//		
※	VD 83 50 00	Switch, Slide	SSSF 1-3	スライドスイッチ	SW501,502,527,528		
※	VD 83 51 00	//	SSSF 1-4	//	SW529		
※	VD 83 52 00	Switch, Push	SPPH2	プッシュスイッチ	SW525,526		

※New Parts (新規部品)

Ref. No.	Part No.	Description	部品名	Remarks	Common Model	Markets	ランク
※	VD 85 33 00	Phones Jack	Black	ヘッドホンジャック	JK501	Black	
※	VD 85 35 00	//	Gray	//	//	Silver	
※	VD 85 31 00	Remote Control Receptor Unit	GPIU501	リモコン受光ユニット	V501		
※	VD 98 50 00	Operation Connector Ass'y		オペレーション Ass'y			
※	FG 24 41 00	Ceramic Cap.	0.01μF 50V	セラコン	C502	Silver	
※	FG 44 41 00	//	0.01μF 50V	//	C501		
※	VD 79 78 00	LCD Unit		LCDユニット			
	FP 33 71 00	TA, Solid Electrolytic Cap.	10μF 16V	タンタルコン			
	UD 11 28 20	Ceramic Chip Capacitor	820P	チップコン			
	VB 36 47 00	Chip Resistor	56kΩ	チップ抵抗			
	XB 76 40 01	IC	LC7583A	I C			

※New Parts (新規部品)

KX-W900/W900U

A

B

C

D

E

KX-W900/W900U

EXPLODED VIEW

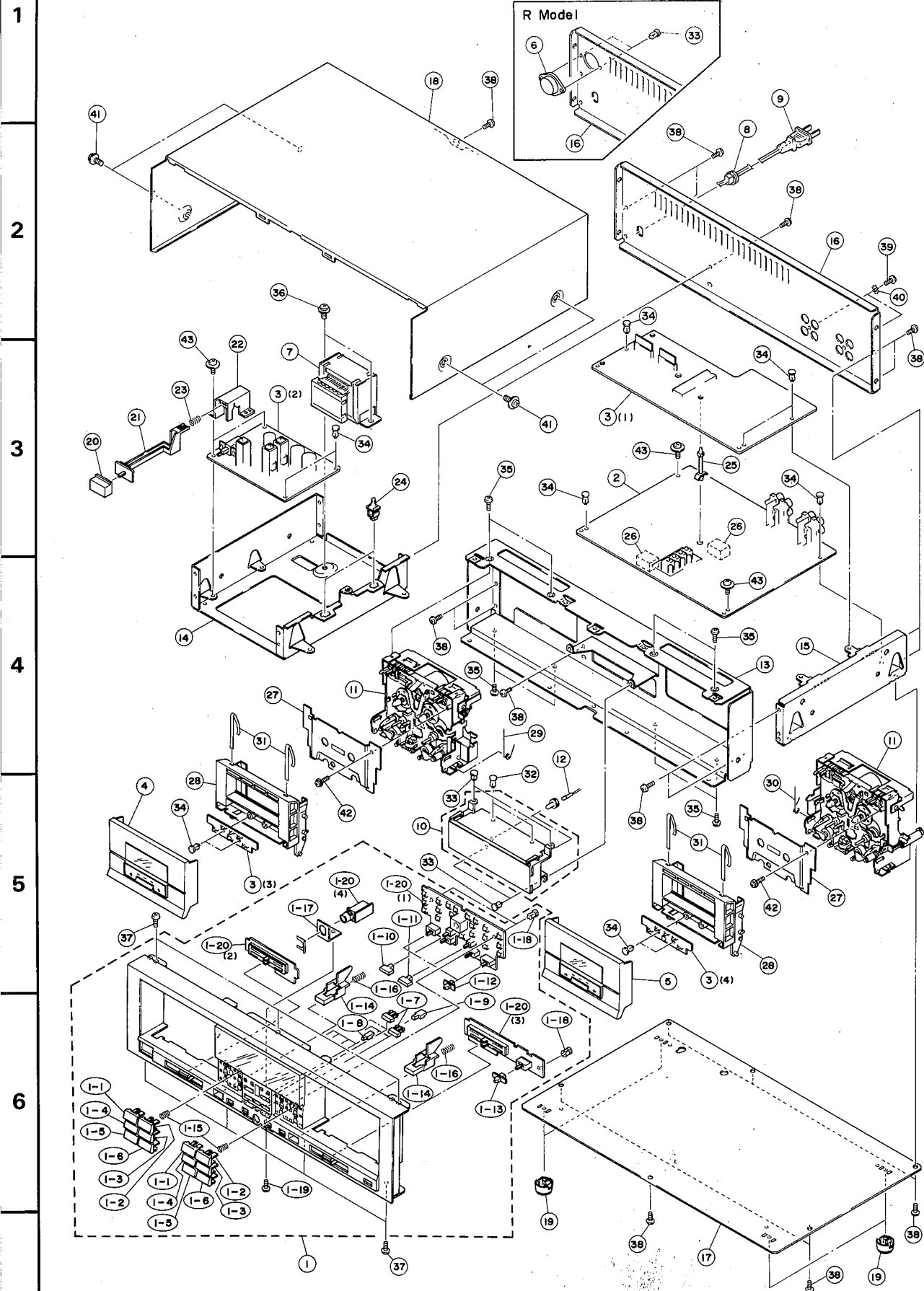

KX-W900/W900U

EXPLODED VIEW PARTS

Ref. No.	Part No.	Description	部品名	Remarks	Common Model	Markets	ランク
※ 1	VD: 82: 12: 00	Panel Unit	パネルユニット	Black		R, A, B, G	
※ //	VD: 82: 13: 00	//	//	Black		U, C	
※ //	VD: 82: 15: 00	//	//	Silver		R, A, B, G	
※ //	VD: 82: 16: 00	//	//	Silver		U, C	
※ 1-1	VD: 46: 83: 00	Button, Play	プレイボタン	Silver			
※ //	VD: 46: 84: 00	//	//	Black			
※ 1-2	VD: 46: 85: 00	Button, Stop	ストップボタン	Silver			
※ //	VD: 46: 86: 00	//	//	Black			
※ 1-3	VD: 46: 87: 00	Button, FF	FF ボタン	Silver			
※ //	VD: 46: 88: 00	//	//	Black			
※ 1-4	VD: 46: 89: 00	Button, REW	REW ボタン	Silver			
※ //	VD: 46: 90: 00	//	//	Black			
※ 1-5	VD: 46: 91: 00	Button, REC	REC ボタン	Silver			
※ //	VD: 46: 92: 00	//	//	Black			
※ 1-6	VD: 46: 93: 00	Button, Mute	MUTE ボタン	Silver			
※ //	VD: 46: 94: 00	//	//	Black			
※ 1-7	VD: 46: 95: 00	Button, L	ボタン (L)	Silver			
※ //	VD: 46: 96: 00	//	//	Black			
※ 1-8	VD: 46: 97: 00	Button, S	ボタン (S)	Silver			
※ //	VD: 46: 98: 00	//	//	Black			
※ 1-9	VD: 75: 63: 00	Button, M	ボタン (M)	Silver			
※ //	VD: 75: 64: 00	//	//	Black			
※ 1-10	VD: 47: 01: 00	Button, Relay	RELAY ボタン	Silver			
※ //	VD: 47: 02: 00	//	//	Black			
※ 1-11	VD: 48: 50: 00	Button, Skip	SKIP ボタン	Silver			
※ //	VD: 48: 51: 00	//	//	Black			
※ 1-12	VD: 47: 03: 00	Knob, Reverse Mode, Dolby	REVERSE MODE DOLBY ボタン	Silver			
※ //	VD: 47: 04: 00	//	//	Black			
※ 1-13	VD: 76: 60: 00	Knob, Timer	TIMER ボタン	Silver			
※ //	VD: 76: 61: 00	//	//	Black			
※ 1-14	VD: 76: 62: 00	Button, Eject	EJECT ボタン	Silver			
※ //	VD: 76: 64: 00	//	//	Black			
※ 1-15	VD: 83: 71: 00	Spring	スプリング				
※ 1-16	VD: 83: 72: 00	Spring, Eject	EJECT スプリング				
※ 1-17	VD: 79: 44: 00	Support (PHONES)	サポート				
※ 1-18	CB: 60: 56: 20	Plastic Rivet	プラスチックリベット				
※ 1-19	Ei: 33: 00: 86	Binding Head Tapping Screw	3×8 FCRM3-BI バインドタッピングネジ	PACK			
※ 1-20	NA: 09: 54: 70	Operation Circuit Board	オペレーションシート	Black			
※ //	NA: 09: 60: 70	//	//	Silver			
※ 2	NA: 09: 53: 80	Main Circuit Board	メインシート				
※ 3	NA: 09: 54: 00	Sub Circuit Board	サブシート			U, C	
※ //	NA: 09: 54: 10	//	//			R	
※ //	NA: 09: 54: 20	//	//			A, B, G	
※ 4	VD: 82: 20: 00	Lid Ass'y (Deck-1)	リッド (デッキ1)	Black			
※ //	VD: 82: 21: 00	// (Deck-1)	// (デッキ1)	Silver			
※ 5	VD: 82: 22: 00	Lid Ass'y (Deck-2)	リッド (デッキ2)	Black			
※ //	VD: 82: 23: 00	// (Deck-2)	// (デッキ2)	Silver			
※ 6	LB: 20: 14: 80	Voltage Selector	0211 電圧切換器			R	
※ 7	XD: 08: 80: 01	Power Transformer	電源トランス			U, C	
※ //	XD: 08: 90: 01	//	//			R	
※ //	XD: 09: 00: 01	//	//			A, B	
※ //	XD: 09: 10: 01	//	//			G	

※ New Parts (新規部品)

7

38

39

Ref. No.	Part No.	Description	部 品 名	Remarks	Common Model	Markets	ランク
※ 8	CB 62 01 90	Cord Stopper	CM-22B	コードストッパ		R,A,B,G	
※ //	CB 62 02 00	//	CM-22C	//		U,C	
※ 9	MG 00 09 20	Power Cord	7.5A 250V 2.5m	電源コード	Interchangeable	A	
※ //	MG 00 14 90	//	7.5A 250V 2.5m	//		A	
※ //	MG 00 23 10	//	7.5A 250V 2m	//		A	
※ //	MG 00 14 50	//	10A 125V 2m	//	Interchangeable	U,C	
※ //	MG 00 14 60	//	10A 125V 2m	//		U,C	
※ //	MG 00 16 20	//	2.5A 250V 2m	//	Interchangeable	G	
※ //	MG 00 23 20	//	2.5A 250V 2m	//		G	
※ //	MG 00 16 30	//	6A 250V 2m	//		R	
※ //	MG 00 18 60	//	2.5A 250V 2m	//	B		
※ 10	VD 79 78 00	LCD Unit		LCD ユ ニ ッ ト			
※ 11	VD 46 57 00	Cassette Mechanism		カセットメカ	DECK-1		
※ //	VD 46 58 00	//		//	DECK-2		
12	VC 21 83 00	Lamp	150mA 8V	ランプ			
※ 13	VD 46 59 00	Sub Chassis		サブシャーシ			
※ 14	VD 46 60 00	Frame L		フレーム L			
※ 15	VD 46 61 00	Frame R		フレーム R			
※ 16	VD 46 63 00	Rear Panel		リアパネル		R	
※ //	VD 46 64 00	//		//		U,C	
※ //	VD 46 65 00	//		//		A,B	
※ //	VD 46 66 00	//		//		G	
※ 17	VD 46 67 00	Bottom Cover		ボトムカバー			
※ 18	VD 46 68 00	Top Cover		トップカバー	Silver		
※ //	VD 46 69 00	//		//	Black		
19	CB 61 03 90	Leg		脚			
※ 20	VD 46 99 00	Button, Power		POWER ボタン	Silver		
※ //	VD 47 00 00	//		//	Black		
※ 21	VD 47 05 00	Lod, Switch		スイッチロッド			
※ 22	VD 47 06 00	Support, Switch		スイッチサポート			
23	VB 95 81 00	Spring		スプリング			
24	CB 60 13 00	Support, PCB		基板ホルダー			
※ 25	VD 83 70 00	//		//			
26	VC 80 41 00	Cushion	15×20×12	クッション			
※ 27	VD 79 45 00	Plate		ブラインドプレート			
※ 28	VD 47 07 00	Housing, Frame		ハウジングフレーム			
※ 29	VD 47 13 00	Spring (Door L)		スプリング	DECK-1		
※ 30	VD 47 14 00	// (Door R)		//	DECK-2		
31	VA 26 58 00	Holder, SP		SPホルダー			
32	CB 09 96 00	Plastic Rivet		プラスチックリベット			
33	CB 06 88 80	//		//			
34	CB 60 56 20	//		//			
35	EB 33 00 86	Flat Head Tapping Screw	3×8 FNM3-BI	皿タッピングネジ	PACK		
36	EZ 00 11 10	Cup Tyte Screw	4×8 ZMC2-Y	カップネジ			
37	Ei 33 00 66	Bind Head Tapping Screw	3×6 FCRM3-BI	バインドタッピングネジ			
38	Ei 33 00 86	//	3×8 FCRM3-BI	//			
39	Ei 33 01 06	//	3×10 FCRM3-BI	//	PACK		
40	EV 41 30 36	Toothed Lock Washer	M3 FCRM3-BI	歯付座金	PACK		
41	EK 13 00 20	BW Head Screw	4×8 FNM3-3g	BWヘッド小ネジ	Silver		
//	EK 36 50 40	//	4×8 FCRM3-BI	//	Black		
42	EX 60 02 10	//	2.5×12 FCRM3-BI	//			
43	EK 33 60 10	BW Head Tapping Screw	3×8 FCRM3	BWヘッドタッピングネジ			

※New Parts (新規部品)

Ref. No.	Part No.	Description	部 品 名	Remarks	Common Model	Markets	ランク
	CB 06 92 50	Binding Tie	BK-I	インシュロックタイ			
		Accessories		付 属 品			
※	VE 23 38 00	Pin Cord Ass'y		ピンコード Ass'y			
※	VD 35 75 00	Remote Control Transmitter		リモコントランスミッター	Black		
※	VD 35 76 00	//		//	Silver		
		Dry Battery	AA, R06	単 三 電 池			

※New Parts (新規部品)

KX-W900/W900U

A

B

C

D

E

F

G

H

I

KX-W900/W900U

MECHANISM EXPLODED VIEW

1

2

3

4

5

6

7

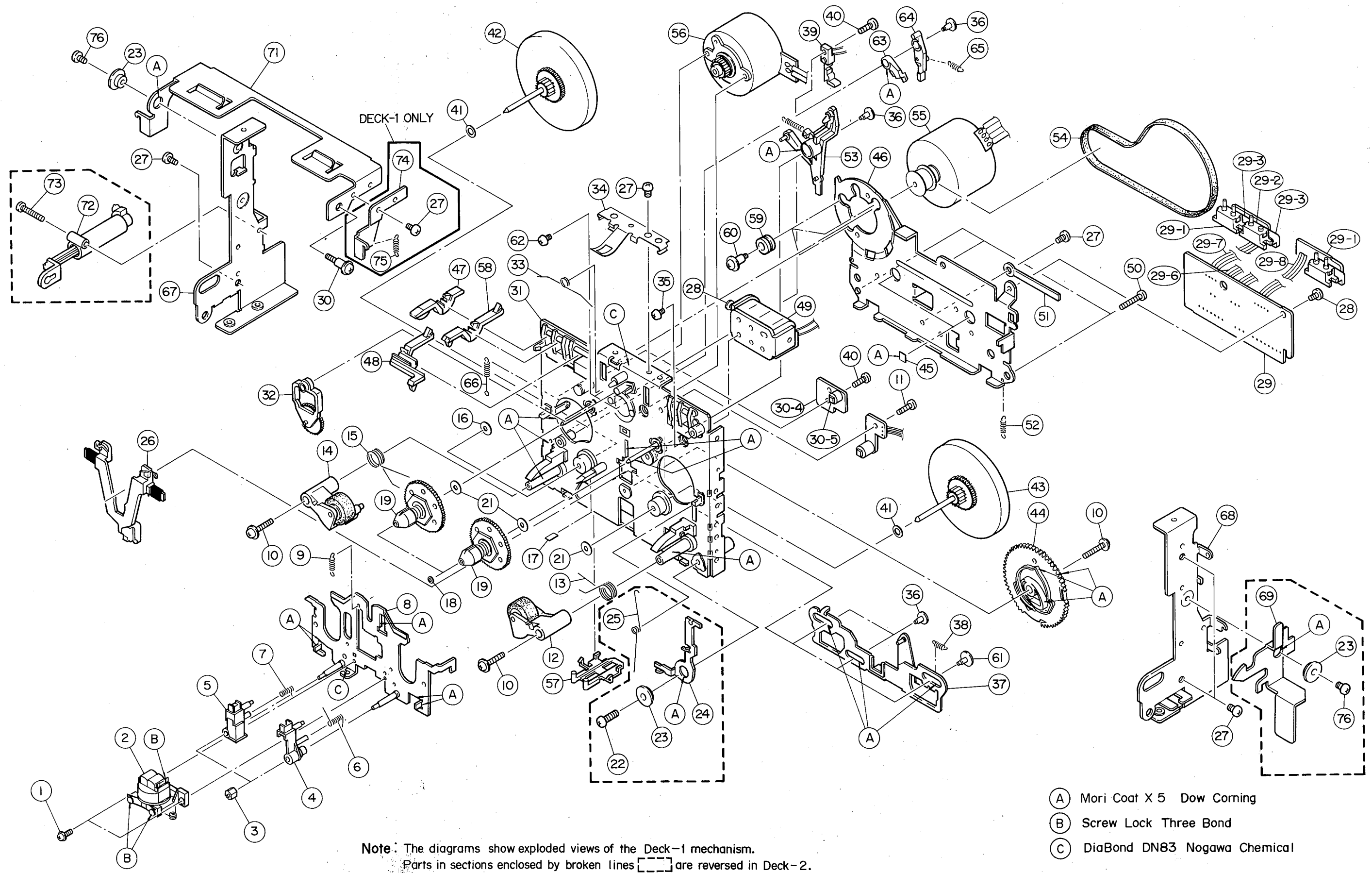

Note: The diagrams show exploded views of the Deck-1 mechanism.
 Parts in sections enclosed by broken lines [] are reversed in Deck-2.

- (A) Mori Coat X 5 Dow Corning
- (B) Screw Lock Three Bond
- (C) DiaBond DN83 Nogawa Chemical

MECHANISM PARTS

Ref. No.	Part No.	Description	部品名	Remarks	Common Model	Markets	ランク
※	VD 46 57 00	Cassette Mechanism	カセットメカ	DECK-1			
※	VD 46 58 00	//	//	DECK-2			
1	XX 64 90 80	Screw with Washer	ワッシャー付ネジ				
※	2	XX 69 51 20	Rotary Head	回転ヘッド組立品	DECK-1		
※	//	XX 69 51 10	//	DECK-2			
3	XX 64 87 20	Nut	調整ナット				
4	XX 67 84 30	Tape Guide	テープガイド				
※	5	XX 69 51 40	Sensor Ass'y	センサー組立品	DECK-1		
※	//	XX 69 51 30	//	DECK-2			
6	XX 64 87 50	Spring (R)	調整スプリング(R)				
7	XX 68 43 40	Spring (L)	// (L)				
8	XX 68 43 50	Head Base	プレートヘッド準備品				
9	XX 64 17 60	Head Base Spring	ヘッドベーススプリング				
10	XX 68 53 20	Screw	ウェーブネジ	2×13			
※	11	XX 69 53 50	//	2×6			
12	XX 64 17 90	Pinch Roller	ピンチローラ組立品				
13	XX 64 18 00	Pinch Roller Spring (R)	ピンチローラスプリング(R)				
14	XX 68 47 60	Pinch Roller	ピンチローラ組立品				
15	XX 68 43 60	Pinch Roller Spring (L)	ピンチローラスプリング(L)				
※	16	XX 69 53 70	Washer	ワッシャーオイルシール			
17	XX 64 90 50	Reflection Plate	反射板				
18	XX 63 66 10	Washer	ポリスライダ				
19	XX 67 03 10	Take Up Reel Ass'y	T. リール組立品				
20	XX 64 18 50	Washer	ポリスライダ				
21	XX 67 02 50	//	ワッシャーオイルシール				
※	22	XX 69 53 60	Screw	ウェーブネジ	3×10	DECK-1	
23	XX 63 64 70	Spacer	スペーサー				
24	XX 68 43 80	Arm (L)	EJECT防止アーム(L)	DECK-1			
//	XX 68 47 90	Arm (R)	// (R)	DECK-2			
25	XX 64 18 30	Spring (L)	EJECT防止スプリング(L)	DECK-1			
//	XX 68 48 00	Spring (R)	// (R)	DECK-2			
※	26	XX 69 51 50	Brake	ブレーキ組立品			
27	EJ 03 00 46	Tapping Screw	タップタイトネジ	3×4			
※	28	XX 69 51 60	Plunger	プランジャー			
※	29	XX 69 51 80	Connector Ass'y	コネクター配線品	DECK-1		
※	//	XX 69 51 70	//	DECK-2			
29-1	XX 64 89 80	Push Switch	プッシュスイッチ				
29-2	XX 64 89 70	//	//				
29-3	XX 68 44 30	Spacer	SWスペーサー				
29-4	XX 68 44 50	Sensor, Reel	リールセンサー	GP2502B	KX-W500		
29-5	XX 68 44 60	Spacer	ホトスペーサー				
29-6	XX 68 48 20	Relay Circuit Board	中継基板				
※	29-7	XX 69 51 90	Sensor, Reel	リールセンサー	GP2509B		
29-8	XX 68 44 40	Spacer	スペーサー				
30	XX 68 46 60	Screw	段付Sタイトネジ				
31	XX 68 44 70	Chassis	シャーシ準備品				
32	XX 68 44 80	Idler	アイドル組立品				
33	XX 64 19 40	Hold Spring	ホールドスプリング				
※	34	XX 69 52 00	Spring	カセット押えバネ			
35	XX 64 19 30	Screw with Washer	ワッシャー付ネジ				
36	XX 64 20 00	Cap	キャップ				
37	XX 68 44 90	Slide Plate	スライド板準備品				

※New Parts (新規部品)

Ref. No.	Part No.	Description	部品名	Remarks	Common Model	Markets	ランク
38	XX 64 89 20	Slide Spring	スライドスプリング				
39	XX 64 19 20	Leaf Switch	リーフスイッチ				
40	XX 68 45 00	Screw	ウェーブネジ	2×7			
41	XX 63 68 10	Washer	ポリスライダ				
※	42	XX 69 52 10	Flywheel	F/W Ass'y			
※	43	XX 69 52 20	//	//			
※	44	XX 69 52 30	Cam Gear (G)	カムギヤ(G)			
※	45	XX 69 52 40	Spacer	角スペーサー			
46	XX 64 20 50	Flywheel Bracket (B)	F/Wブラケット(B)				
※	47	XX 69 52 50	Lever (Pack)	バック検知レバー			
48	XX 64 89 60	Lever (Metal)	メタル検知レバー				
49	XX 68 45 50	Coil for Plunger	プランジャーコイル	30Ω PKA16138/AY			
50	XX 68 48 90	Screw	ウェーブネジ	2.6×8			
51	XX 68 45 60	Lug	ラグ				
※	52	XX 69 52 60	Spring for Ground	アーススプリング			
※	53	XX 69 52 70	Play Arm	プレイアーム組立品			
54	XX 68 45 80	Main Belt	メインベルト				
55	XX 67 02 80	Motor, Main	メインモーター				
56	XX 64 88 50	Motor, Reel	リールモーター				
57	XX 64 89 40	Lead Holder	リードホルダー				
※	58	XX 69 52 80	Lever (REC)	REC検知レバー			
59	XX 66 27 30	Cushion, Motor	モータークッション				
60	XX 67 03 60	Screw	モーター取付ネジ				
61	XX 64 89 40	Cap	キャップ				
62	XX 64 90 90	Pan Head Tapping Screw	ナベタッピングネジ	2.6×6	PACK		
63	XX 64 90 20	Arm (A)	アーム(A)				
64	XX 68 46 10	Arm (B)	// (B)				
65	XX 68 46 20	Spring, Arm	アームスプリング				
66	XX 68 46 30	Spring, Reverse	反転スプリング				
※	67	XX 69 52 90	Damper Bracket (L)	ダンパーブラケット(L)			
※	68	XX 69 53 00	Damper Bracket (R)	// (R)			
※	69	XX 69 53 20	Lever, Eject (R)	EJECTレバー(R)	DECK-1		
※	70	XX 69 53 10	Lever, Eject (L)	// (L)	DECK-2		
※	71	XX 69 53 30	Arm, Eject	EJECTアーム			
72	XX 68 49 60	Damper	ダンパー組立品				
73	XX 66 28 10	Tap Tyte Screw	タップタイトネジ				
※	74	XX 69 53 40	Arm, Eject	EJECTアーム	DECK-1		
75	XX 64 90 10	Spring, Eject Arm	EJECTアームスプリング	DECK-1			
76	XX 68 46 70	Pan Head Tapping Screw	ナベタッピングネジ	3×6			

※New Parts (新規部品)

KX-W900/W900U

● SCHEMATIC DIAGRAM

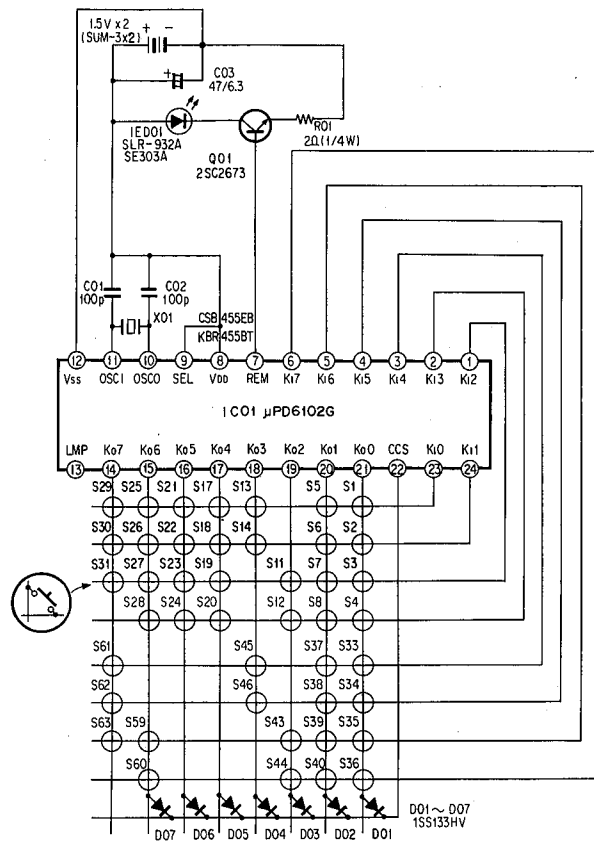

KEY NO.	FUNCTION	DATA CODE
S1	DECK 1 PLAY	00
S2	DECK 1 <<	01
S3	DECK 1 >>	02
S4	DECK 1 STOP	03
S5	DECK 1 REC/PAUSE	04
S6	DECK 1 REC MUTE	05
S7	PHONES 1/2	06
S8	DECK 1 DIR	07
S11	DECK 1 SEARCH >>	0A
S12	DECK 1 SEARCH <<	0B
S13	DECK 1 TAPE	0C
S14	DECK 1 RESET	0D
S17	0	10
S18	1	11
S19	2	12
S20	3	13
S21	4	14
S22	5	15
S23	6	16
S24	7	17
S25	8	18
S26	9	19
S27	PROG	1A
S28	CLEAR	1B
S29	RUN	1C
S30	DECK 1 REMAIN	1D
S31	DECK 1 INTRO	1E
S33	DECK 2 PLAY	40
S34	DECK 2 <<	41
S35	DECK 2 >>	42
S36	DECK 2 STOP	43
S37	DECK 2 REC/PAUSE	44
S38	DECK 2 REC MUTE	45
S39	PROGRAM 1/2	46
S40	DECK 2 DIR	47
S43	DECK 2 SEARCH >>	4A
S44	DECK 2 SEARCH <<	4B
S45	DECK 2 TAPE	4C
S46	DECK 2 RESET	4D
S59	DUBBING MODE	5A
S60	DUBBING SPEED	5B
S61	DUBBING START	5C
S62	DECK 2 REMAIN	5D
S63	DECK 2 INTRO	5E

CUSTOM CODE 7F

● PRINTED CIRCUIT BOARD

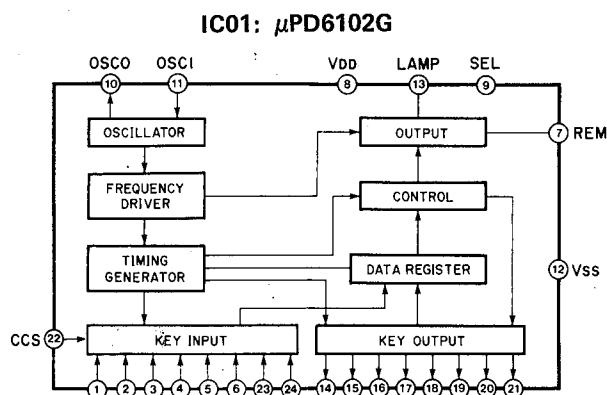
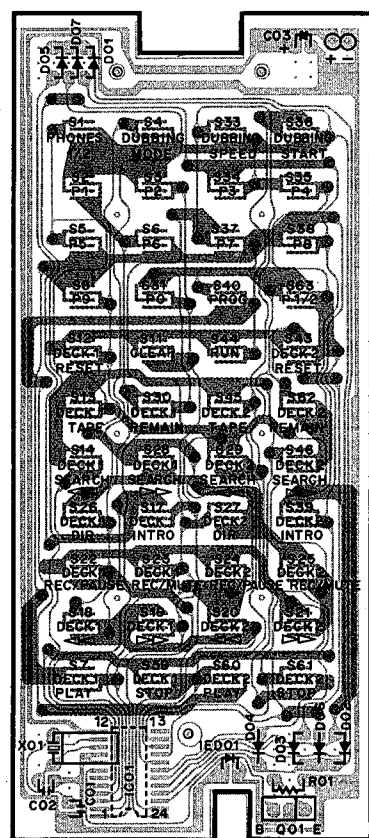

● REMOTE CONTROL TRANSMITTER (RS-KW9)

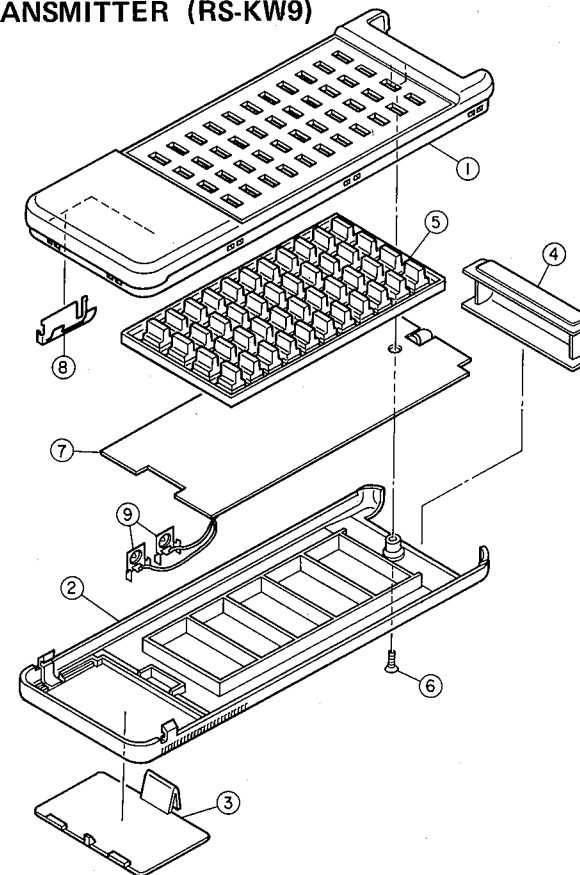

Ref. No.	Part No.	Description	部品名	Remarks	Common Model	Markets	ランク
※	VD 35 75 00	Remote Control Transmitter	RS-KW9	リモートコントロールトランスミッター			
※	VD 35 76 00	"	RS-KW9	"			
※	1 CX 60 12 80	Case (A) Ass'y		ケース (A) Ass'y			
※	// CX 60 12 90	"		"			
※	2 CX 67 77 20	Case (B)		ケース (B)			
※	// CX 60 06 00	"		"			
※	3 XX 67 77 30	Case (C)		ケース (C)			
※	// XX 67 17 20	"		"			
※	4 XX 67 16 40	Filter		フィルター			
※	5 CX 60 06 20	Rubber Contact		ゴム接点			
※	// CX 60 13 00	"		"			
※	6 XX 67 16 60	Flat Head Screw		皿小ネジ			
※	// XX 67 17 50	"		"			
※	7 NX 60 06 70	P.C.Board Ass'y		プリント基板 Ass'y			
※	8 XX 67 16 80	Dry Cell Terminal (A)		電池電極板 (A)			
※	9 XX 67 16 90	" (B)		" (B)			
※	NX 60 06 80	P.C.Board Ass'y		プリント基板 Ass'y			
※	iX 60 70 40	IC	μPD6102G	I C IC01			
※	QX 60 00 40	Ceramic Resonator	KBR-455BT	セラミック振動子			
※	FG 21 21 00	Ceramic Cap.	100pF 50V	セラコン			
※	UJ 11 74 70	Electrolytic Cap.	47μF 6.3V	ケミコン			
※	iC 26 73 00	Transistor	2SC2673	トランジスター			
※	HX 60 14 00	Carbon Resistor	2Ω 1/4W	カーボン抵抗			
※	QX 60 00 40	IED	CSB455EB KBR455BT	I E D IED01			
※	iF 00 34 50	Diode	ISS133HV	ダイオード			

※New Parts (新規部品)

Parts List for Carbon Resistor

Value	1/4W Type Part No.	1/6W Type Part No.	Value	1/4W Type Part No.	1/6W Type Part No.
1.0 Ω	HJ353100	HF85 3100	12KΩ	HJ357120	HF857120
1.8 "	HJ353180	※	15 "	HJ357150	HF857150
2.2 "	HJ353220	HF853220	18 "	HJ357180	HF857180
3.3 "	HJ353330	HF853330	22 "	HJ357220	HF857220
4.7 "	HJ353470	HF853470	27 "	HJ357270	HF857270
5.6 "	HJ353560	HF853560	33 "	HJ357330	HF857330
10 "	HJ354100	HF854100	39 "	HJ357390	HF857390
15 "	HJ354150	HF854150	47 "	HJ357470	HF857470
22 "	HJ354220	HF854220	56 "	HJ357560	HF857560
27 "	HJ354270	HF854270	68 "	HJ357680	HF857680
33 "	HJ354330	HF854330	82 "	HJ357820	HF857820
39 "	HJ354390	HF854390	91 "	HJ357910	HF857910
47 "	HJ354470	HF854470	100 "	HJ358100	HF858100
56 "	HJ354560	HF854560	120 "	HJ358120	HF858120
68 "	HJ354680	HF854680	150 "	HJ358150	HF858150
82 "	HJ354820	HF854820	180 "	HJ358180	HF858180
100 "	HJ355100	HF855100	220 "	HJ358220	HF858220
110 "	HJ355110	HF855110	270 "	HJ358270	HF858270
120 "	HJ355120	HF855120	330 "	HJ358330	HF858330
150 "	HJ355150	HF855150	390 "	HJ358390	HF858390
160 "	HJ355160	※	470 "	HJ358470	HF858470
180 "	HJ355180	HF855180	560 "	HJ358560	HF858560
220 "	HJ355220	HF855220	680 "	HJ358680	HF858680
270 "	HJ355270	HF855270	820 "	HJ358820	HF858820
330 "	HJ355330	HF855330	1.0MΩ	HJ359100	HF859100
390 "	HJ355390	HF855390	1.2 "	HJ359120	※
470 "	HJ355470	HF855470	1.5 "	HJ359150	HF859150
510 "	※	HF855510	1.8 "	HJ359180	HF859180
560 "	HJ355560	HF855560	2.2 "	HJ359220	HF859220
680 "	HJ355680	HF855680	3.3 "	HJ359330	HF859330
820 "	HJ355820	HF855820	3.9 "	HJ359390	※
910 "	HJ355910	HF855910	4.7 "	HJ359470	HF859470
1.0KΩ	HJ356100	HF856100			
1.2 "	HJ356120	HF856120			
1.5 "	HJ356150	HF856150			
1.8 "	HJ356180	HF856180			
2.0 "	HJ356200	HF856200			
2.2 "	HJ356220	HF856220			
2.4 "	HJ356240	HF856240			
2.7 "	HJ356270	HF856270			
3.0 "	HJ356300	HF856300			
3.3 "	HJ356330	HF856330			
3.6 "	HJ356360	HF856360			
3.9 "	HJ356390	HF856390			
4.7 "	HJ356470	HF856470			
5.1 "	HJ356510	HF856510			
5.6 "	HJ356560	HF856560			
6.8 "	HJ356680	HF856680			
8.2 "	HJ356820	HF856820			
9.1 "	HJ356910	HF856910			
10 "	HJ357100	HF857100			

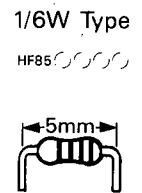
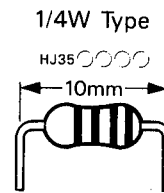

KX-W900/W900U

KX-W900/W900U

YAMAHA

KX-W900/W900U
