

# HEATHKIT VACUUM TUBE VOLTMETER

## MODEL V-7A

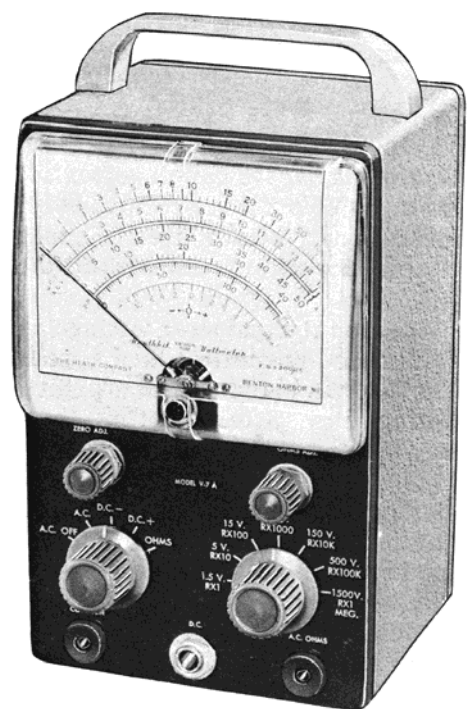

### SPECIFICATIONS

- Electronic D. C. Voltmeter:
  - 7 Ranges:..... 0-1.5, 5, 15, 50, 150, 500, 1500 volts full scale, with accessory probe to 30,000 volts
  - Input Resistance:..... 11 megohms (1 megohm in probe) On all ranges, 1,100 megohms with accessory probe
  - Sensitivity:..... 7,333,333 ohms per volt on 1.5 volt range
  - Circuit:..... Balanced bridge (push-pull) using twin triode
  - Accuracy:.....  $\pm 3\%$  full scale
- Electronic A. C. Voltmeter:
  - 7 R. M. S. Ranges:..... 0-1.5, 5, 15, 50, 150, 500, 1500 scales reading R. M. S. (.353 of peak to peak).
  - Frequency Response (5 v range):..  $\pm 1$  db 42 cps to 7.2 mc (600  $\Omega$  source).
  - Accuracy:.....  $\pm 5\%$  full scale
  - 7 Peak-to-Peak Ranges:..... 0-4, 14, 40, 140, 400, 1400, 4000
- Electronic Ohmmeter:
  - 7 Ranges:..... Scale with 10 ohms center X1, X10, X100, X1000, X10K, X100K, X1MEG. Measures .1 ohm to 1000 megohms with internal battery
- Meter:..... 4 1/2" 200  $\mu$ A movement, Polystyrene case
- Multipliers:..... 1% precision type
- Circuit board:..... Printed circuit, etched metal process 3/32" XXP laminated phenolic .00135 copper foil
- Tubes:..... 1 - 12AU7, twin triode meter bridge  
1 - 6AL5, twin diode full wave AC rectifier
- Battery:..... 1 1/2 volt flashlight cell
- Cabinet Size:..... 7 3/8" high x 4 11/16" wide x 4 1/8" deep charcoal grey panel, feather grey cabinet
- Kit Shipping Weight..... 7 lbs.
- Power Requirements..... 105-125 volt 50-60 cycle AC 10 watts

## INTRODUCTION

This Heathkit model V-7A VTVM represents the first kit instrument using a prewired, prefabricated printed circuit board in its design. The advantages of this circuit board use are numerous and it might be helpful to discuss them briefly before actually entering into kit construction. The printed circuit process itself is very interesting and an outline of the basic method involved will provide a much better understanding of the entire project.

The printed circuit board is actually nothing more than an insulating material on which a metal conductor pattern has been prepared. This metal conductor pattern replaces virtually all of the wiring usually associated with conventional chassis construction. The labor saving thus attained represents one of the principal advantages of printed circuit use. Other advantages are exact duplication of engineering development model, elimination of construction variations due to individual assembly techniques, more compact efficient construction and reduced margin of error.

There are many methods by which the metal conductor pattern is obtained and at the present time, the etching of a copper clad laminated phenolic board appears to be the most logical and flexible one. Usually a copper clad surface is subjected to a printing process such as is used in photography, silk screen, offset printing, etc. After printing, the unwanted metal not protected by the printing pattern is etched away leaving the desired pattern.

Generally speaking, the same soldering techniques with which you are already familiar will apply. It is recommended that a smaller soldering iron with a small tip be used. Irons in the range of 25 or 50 watts are entirely adequate. Soldering pencils are ideal for this work. Quick heating solder guns can be used but some precaution should be observed regarding the possibility of overheating. Overheating will damage the copper foil or the board and the practice itself should be discouraged in this assembly technique. Should the circuit board become overheated through soldering, the condition will be immediately evident by a distinctly audible "frying" or "crackling."

You will note that on the reverse side of the circuit board, a silk screening process actually designates the placement of components and identifies them by electrical value. To install a condenser or resistor, it is merely necessary to hold the component in one hand and bend both leads downward with the other hand forming a U-shaped unit. Then it is merely necessary to insert the leads through the openings provided and place the resistor or condenser directly over the designated area on the board. Spread the leads slightly so as to keep the units in place and prevent shifting. Usually many components can be mounted and then a number of soldered connections can be made without requiring frequent handling or turning of the board. After making the solder connection, the remaining leads should be trimmed off close to the board.

Tube sockets are mounted in a similar manner by inserting the socket pins in the circuit board cutout provided and properly aligning the socket. The pins can then be quickly soldered to the corresponding terminals for good electrical connection and at the same time provide adequate mechanical construction.

A properly prepared circuit board will provide many years of trouble-free service. There will be no deterioration of electrical connections or continuity of circuits and of course no separation of the copper and laminate. Your Heathkit represents the most widely accepted VTVM in the electronics industry. Properly constructed and intelligently used, it will provide many years of accurate trouble-free measurement service.

## PRELIMINARY NOTES AND INSTRUCTIONS

The Heathkit model V-7A Peak-to-Peak Vacuum Tube Voltmeter is an excellent instrument and care used during construction will be well repaid. The construction is open and easily accomplished but it should not be rushed, as poor workmanship can result in poor operation.

**UNPACK THE KIT CAREFULLY, EXAMINE EACH PART AND CHECK IT AGAINST THE PARTS LIST.** In so doing, you will become acquainted with the parts. If a shortage is found, attach the inspection slip to your claim and notify us promptly. Hardware items are counted mechanically and if a few are missing, please secure them locally if at all possible. Use the charts on the inside covers of this manual to identify the parts.

Read the manual completely through before starting actual construction. In this way, you will become familiar with the general procedure used. Study the pictorials and diagrams to get acquainted with the circuit layout and location of parts. When actually assembling and wiring, read the entire step through so that no suggestions will be missed.

To facilitate describing the location of parts, tube sockets, controls, terminal strips, etc. have all been lettered and are coded. All such numbering and lettering is clearly shown in the figures and when instructions say, for example, "wire to G3" refer to the proper figure and connect a wire to pin 3 of socket G.

It is recommended that O, Z, P, etc. be actually labeled as such on the panel with a pencil. Lettering on the inside of the panel where wiring is done will reduce the possibility of making wrong connections.

Tube socket pins are numbered as shown in Figure 5. Always read clockwise when the socket is viewed from the bottom.

A circuit description is included in the later section of this manual so that those with some knowledge of electronics will be able to obtain a clearer picture of the actual functioning of this instrument. It is not expected that those with little experience will understand the description completely, but it should be of help in the event that they desire to become more familiar with the circuit operation and thus learn more from building the kit than just the placing of parts and wiring.

Small changes in parts may be made by the Heath Company. Any part supplied will work just as well as the part for which it was substituted. By reading the color code on resistors for instance, it will be readily understood that a value of 51 K $\Omega$  is a substitute for the specified 47 K $\Omega$  provided the specified value is not supplied. Such changes will be made only if the specified parts are unobtainable at the time and are made to insure a minimum delay in filling your order.

Resistors and controls have a tolerance rating of  $\pm 20\%$  unless otherwise stated. Therefore a 100 K $\Omega$  resistor may test anywhere between 80 K $\Omega$  and 120 K $\Omega$ . Frequently condensers show an even greater variation such as -50% to +100%. This Heathkit is designed to accommodate such variations.

#### PROPER SOLDERING PROCEDURE

Only a small percentage of Heathkit purchasers find it necessary to return an instrument for factory service. Of these, by far the largest proportion function improperly due to poor or improper soldering.

Correct soldering technique is extremely important. Good solder joints are essential if the performance engineered into the kit is to be fully realized. If you are a beginner with no experience in soldering, a half-hour's practice with odd lengths of wire and a tube socket will be a worthwhile investment.

High quality solder of the proper grade is most important. There are several different brands of solder on the market, each clearly marked "Rosin Core Radio Solder." Such solders consist of an alloy of tin and lead, usually in the proportion of 50:50. Minor variations exist in the mixture such as 40:60, 45:55, etc. with the first figure indicating the tin content. Radio solders are formed with one or more tubular holes through the center. These holes are filled with a rosin compound which acts as a flux or cleaning agent during the soldering operation.

NO SEPARATE FLUX OR PASTE OF ANY KIND SHOULD BE USED. We specifically caution against the use of so-called "non-corrosive" pastes. Such compounds, although not corrosive at room temperatures, will form residues when heated. The residue is deposited on surrounding surfaces and attracts moisture. The resulting compound is not only corrosive but actually destroys the insulation value of non-conductors. Dust and dirt will tend to accumulate on these "bridges" and eventually will create erratic or degraded performance of the instrument.

NOTE: ALL GUARANTEES ARE VOIDED AND WE WILL NOT REPAIR OR SERVICE INSTRUMENTS IN WHICH ACID CORE SOLDER OR PASTE FLUXES HAVE BEEN USED. WHEN IN DOUBT ABOUT SOLDER, IT IS RECOMMENDED THAT A NEW ROLL PLAINLY MARKED "ROSIN CORE RADIO SOLDER" BE PURCHASED.

If terminals are bright and clean and wires free of wax, frayed insulation and other foreign substances, no difficulty will be experienced in soldering. Crimp or otherwise secure the wire (or wires) to the terminal, so a good joint is made without relying on solder for physical strength. To make a good solder joint, the clean tip of the soldering iron should be placed against the joint to be soldered so that the terminal is heated sufficiently to melt solder. The solder is then placed against both the terminal and the tip of the iron and will immediately flow out over the joint. Refer to the sketch below. Use only enough solder to cover wires at the junction; it is not necessary to fill the entire hole in the terminal with solder. Excess solder may flow into tube socket contacts, ruining the socket, or it may creep into switch contacts and destroy their spring action. Position the work so that gravity tends to keep the solder where you want it.

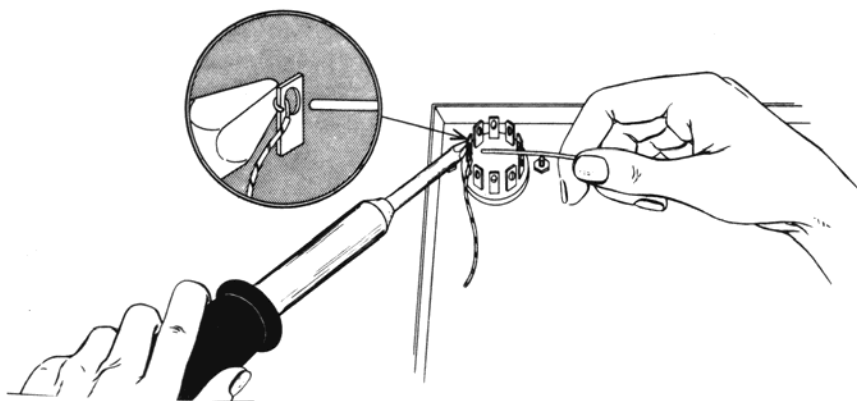

A poor solder joint will usually be indicated by its appearance. The solder will stand up in a blob on top of the connection, with no evidence of flowing out caused by actual "wetting" of the contact. A crystalline or grainy texture on the solder surface, caused by movement of the joint before it solidified is another evidence of a "cold" connection. In either event, reheat the joint until the solder flows smoothly over the entire junction, cooling to a smooth, bright appearance. Photographs in the adjoining picture clearly indicate these two characteristics.



A good, clean, well-tinned soldering iron is also important to obtain consistently perfect connections. For most wiring, a 60 or 100 watt iron, or the equivalent in a soldering gun, is very satisfactory. Smaller irons generally will not heat the connections enough to flow the solder smoothly over the joint and are recommended only for light work, such as on etched circuit boards, etc. Keep the iron tip clean and bright. A pad of steel wool may be used to wipe the tip occasionally during use.

Take these precautions and use reasonable care during assembly of the kit. This will insure the wonderful satisfaction of having the instrument operate perfectly the first time it is turned on.

## RANGE SWITCH ASSEMBLY

The range switch is the very heart of the VTVM multiplier circuit and careful workmanship here will reward the kit builder with trouble-free performance. This switch has been especially designed for the Heathkit VTVM. It is important that solder connections be well made with a clean, hot, well tinned iron, small tip preferred. Avoid excessive use of solder or flux. Do not overheat or burn the switch wafers. Complete absence of any potential leakage path is desirable. The switch assembly is entirely logical and the step-by-step procedure should be carefully followed. Take your time, be sure of each step and do a good job.

The range switch is the long, 3-deck rotary switch, part #63-79. Inspect the switch for alignment by holding it vertically and sighting from one side to determine if the switch shaft and stacked tubular wafer separators are all parallel to each other. If the assembly is misaligned, probably due to handling or shipping, alignment should be restored before proceeding with the work. This can be accomplished by holding the metal detent wafer at the shaft end in one hand and firmly twisting the SPACERS on the switch deck with the other hand. After aligning, check the tightness of the mounting nuts on the last wafer. They should be snug without excessive strain.

## RANGE SWITCH WIRING

The range switch can be conveniently wired before panel mounting. Study Figure 1 for proper orientation and switch lug designation. Switch lug marking follows a definite pattern. The three decks, front (deck #1), center (deck #2), and rear (deck #3) are all 12-position wafers and terminals will be designated as follows: Front deck, #1 numbered from 1 to 12; Center deck, #2 from 13 to 24; Rear deck, #3 from 25 to 36. NOTE: Before wiring, be sure your switch agrees with the terminal arrangement shown in Figure 1 and described below.

Lug numbering will be called out in clockwise rotation commencing with the front deck. Therefore, R1 will be the front deck lug as identified in Figure 1. The next position, normally R2, is blank followed in continuous succession by R3, R4, etc. Note that on the first deck #1 contact surfaces appear on both sides of the deck. Whereas the remaining decks #2 and #3, the contacts are all on one side of the wafer.

During assembly procedure, mount resistors so that the printed values are visible. This is good practice and will be helpful in the event trouble shooting is required. Trim excess resistor lead length and crimp the lead ends around the switch lug for good mechanical connection. Avoid undue strain on the switch lug itself so that the rivet mounting will not become loosened. Use insulated sleeving whenever bare wire is adjacent to the switch frame or the possibility of shorting to adjacent wiring exists.

Check off each step in the space provided (✓) as it is completed.

(S) means solder the connection.

(NS) means do not solder yet.

USE ROSIN CORE SOLDER ONLY. SEE SOLDER NOTE ON PAGE 4.

Successful instrument construction requires close observance of the step-by-step procedure outlined in this manual. For your convenience, many illustrations are repeated in large size fold-in sheets. It is suggested that these sheets be fastened to the wall over your work area for reference purposes during instrument construction.

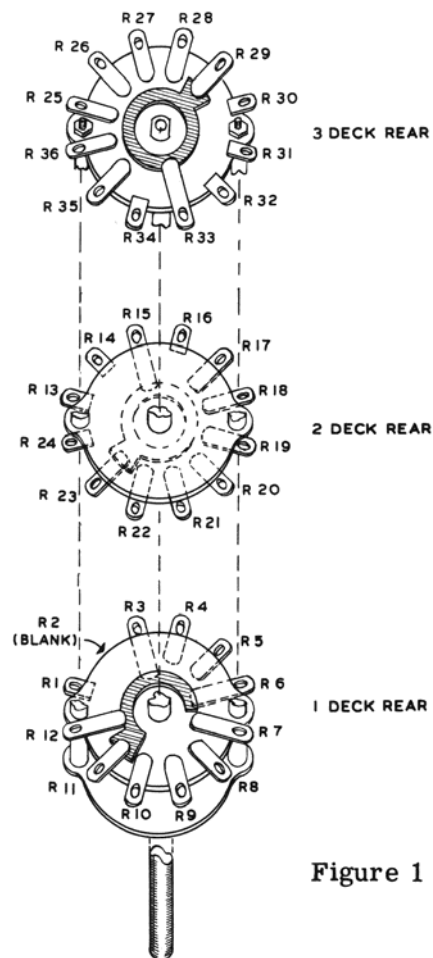
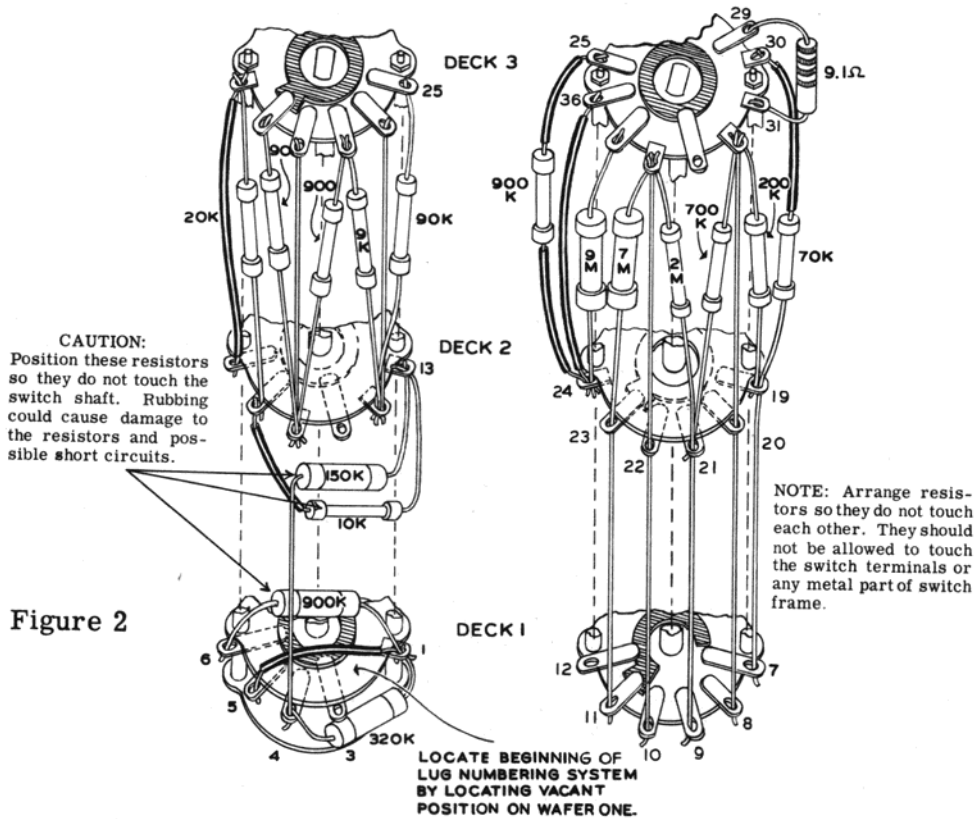

Figure 1

RANGE SWITCH  
NUMBERING SYSTEM

Arrange the supply of precision resistors and begin range switch assembly in the following manner. Be sure of each step before soldering as correction can be annoying.

- ( ) Connect 320 K $\Omega$  resistor between R1 (NS) and R4 (NS). Physical placement is between the wafer and detent plate. See Figure 2.
- ( ) Connect 900 K $\Omega$  1 watt (large) resistor between R1 (NS) and R6 (NS). Place resistor between deck #1 and deck #2. See Figure 2.



RANGE SWITCH DETAIL

- ( ) Connect 150 K $\Omega$  resistor between R13 (NS) and R4 (S). See Figure 2 for placement.
- ( ) Connect 10 K $\Omega$  resistor between R13 (NS) and R17 (NS). Use insulated sleeving on R17 connection.
- ( ) Connect a length of bare wire between R1 (S) and R5 (S). (Use sleeving.)
- ( ) Connect 20 K $\Omega$  resistor between R17 (S) and R30 (NS).
- ( ) Connect a length of bare wire between R30 (NS) and R18 (S). (Use sleeving.)
- ( ) Connect one lead of the 70 K $\Omega$  resistor through R19 (NS) to R7 (S). Use sleeving and connect the remaining lead to R30 (S).
- ( ) Connect 200 K $\Omega$  resistor from R19 (S) to R32 (NS).
- ( ) Connect a bare wire through R32 (NS) and again through R20 (S) and to R8 (S).
- ( ) Connect one lead of the 700 K $\Omega$  resistor through R21 (NS) to R9 (S). Connect the other lead to R32 (S).

- ( ) Connect 2 megohm resistor from R21 (S) to R34 (NS). (Note that R33 is left unconnected during this progressive sequence.)
- ( ) Connect a bare wire through R34 (NS) and on through R22 (S) and to R10 (S).
- ( ) Connect one lead of 7 megohm resistor through R23 (S) and to R11 (NS). Connect the other lead to R34 (S).
- ( ) Connect 9 megohm resistor between R35 (S) to R24 (NS).
- ( ) Connect a bare wire from R36 (S) to R24 (NS). (Use sleeving.)
- ( ) Connect 900 K $\Omega$  resistor from R25 (NS) to R24 (S). (Use sleeving.)
- ( ) Connect 90 K $\Omega$  resistor from R25 (S) to R14 (NS).
- ( ) Connect a bare wire from R26 (S) to R14 (NS).
- ( ) Connect 9 K $\Omega$  resistor from R27 (NS) to R14 (S).
- ( ) Connect 900  $\Omega$  resistor from R27 (S) to R16 (NS). Note that R15 has been skipped at this time.
- ( ) Connect a bare wire from R28 (S) to R16 (NS)
- ( ) Connect a 90  $\Omega$  resistor from R29 (NS) to R16 (S).
- ( ) Connect 9.1  $\Omega$  resistor (colored white and brown) from R29 (S) to R31 (NS). See Figure 2 for resistor placement.

This completes the resistor range switch assembly. Before temporarily setting it aside, recheck the entire procedure to insure accuracy. Check all resistor leads and bare wires for possible shorting. Visually inspect all solder connections from every angle to make sure that a poor solder connection is not present. Check for the possibility of excess solder used on connections shorting to adjacent connections. Shake out all loose pieces of solder and wire trimmings.

## PANEL

In all operations involving panel assembly and wiring, a soft cloth or pad should be placed on the working surface so that the panel will not become marred or damaged by handling.

Refer to Figure 3 for explanation of parts mounting on panel. Note the placement of controls in respect to lug positioning. On all controls and switches be sure to use a control lockwasher between the panel and the control or switch. Use a flat nickel washer under the control mounting nut to prevent marring the panel.

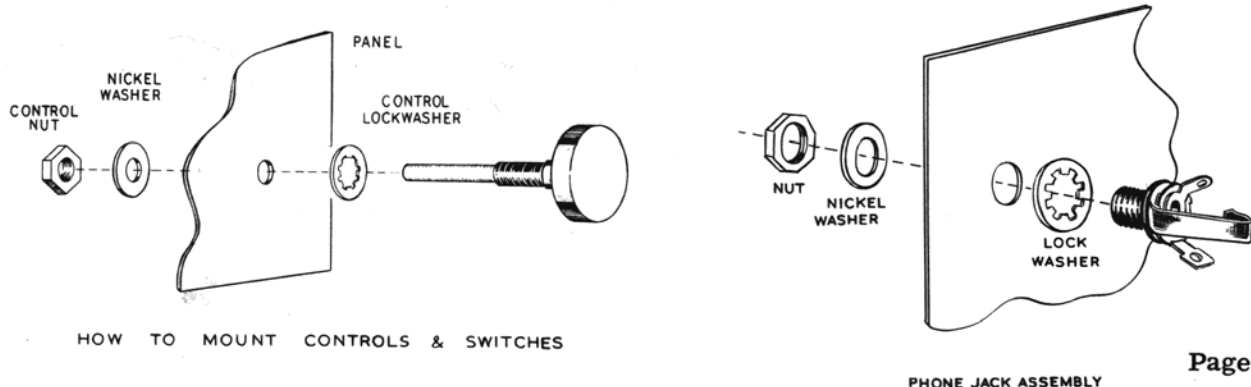

NOTE: Orient both switches before wiring. Position as shown in this figure and then install the knobs so switches can be moved slightly as required to align knob markers with panel index markers. The knob set-screw should tighten on the "flat" of the switch shaft. Firmly retighten control nuts.

NOTE: Place switch at approximately 30° angle to panel edge.

Figure 3

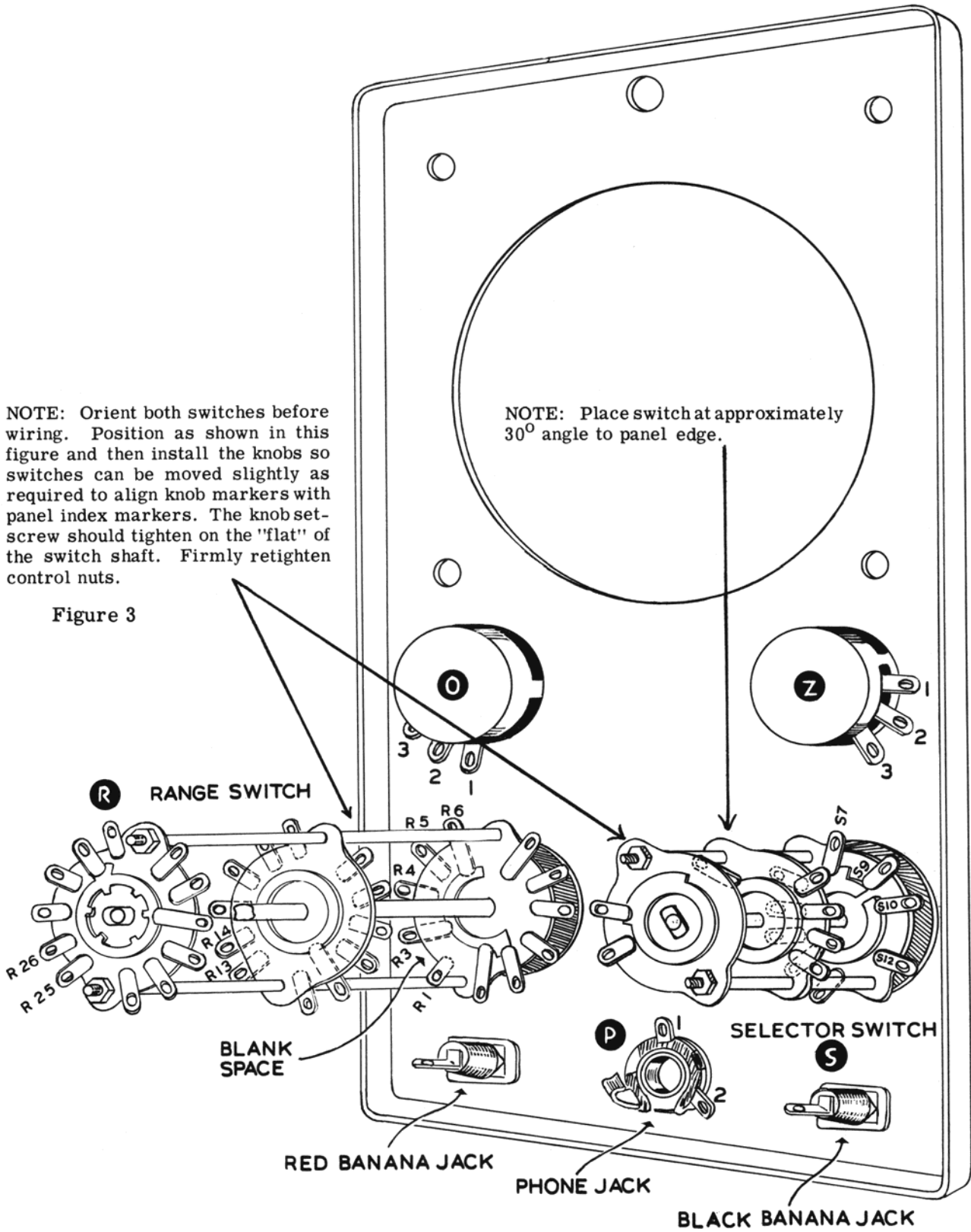



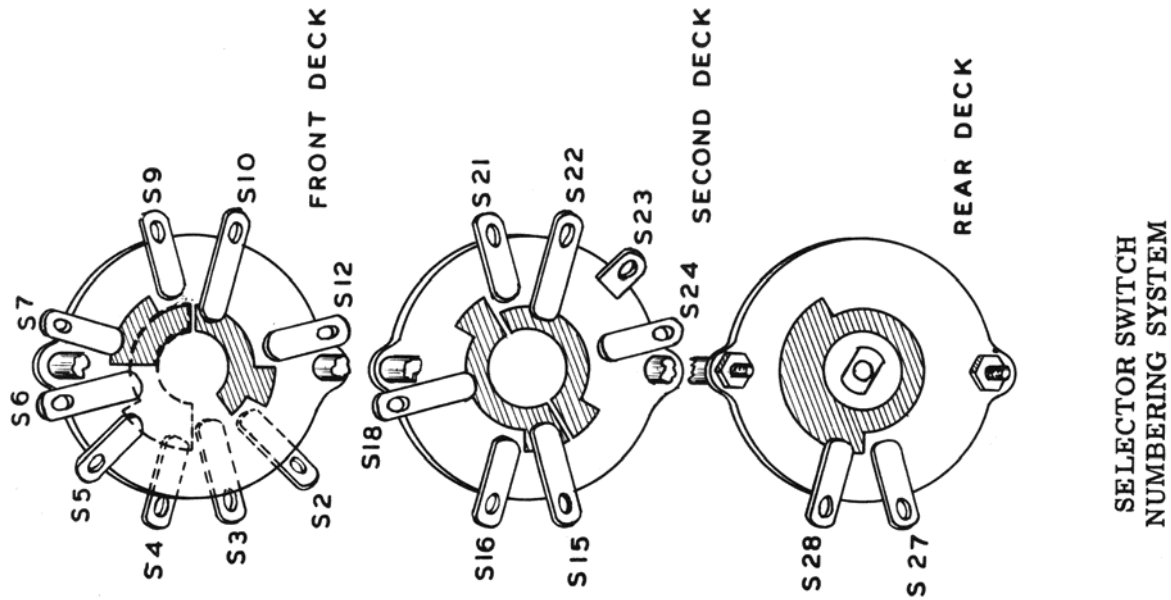

Banana jacks are mounted in the positions shown. Observe the correct color placement. After inserting banana jack inserts, be sure to bend slightly as shown in Figure 4.

Please note alphabetical designations of controls, switches and other points of connection. For example, OHMS ADJUST will be designated as "O" and the lugs numbered O1, O2, O3. ZERO ADJUST as "Z" and lugs Z1, Z2, Z3, etc.

#### PANEL WIRING

Note that the use of insulated sleeving is specified in some of the following wiring procedure. This sleeving is used to cover the whole length of the hookup wire involved in the step, and its purpose is to insure adequate clearance between that particular section of wire and adjacent wiring and parts. Use of sleeving is specified only in circuits carrying high AC test voltage and the purpose of the sleeving is to prevent arcing or flashover due to wiring dress.

- ( ) Install a .01  $\mu$ fd 1600 volt condenser between R6 (S) and S12 (S). (Use sleeving.) Observe condenser placement as shown in Pictorial 1 on the following page.
- ( ) Connect a wire from O3 (S) to S16 (S).
- ( ) Connect a wire from O2 (S) to Z1 (NS).
- ( ) Connect a wire from Z3 (S) to S18 (NS).
- ( ) Connect a wire from S2 (S) to P2 (S).
- ( ) Connect a wire from S3 (S) to R11 (S).
- ( ) Connect a wire from S5 (S) to R15 (S). Note that S4 is skipped at this time.
- ( ) Connect a wire from S7 (S) to R12 (S). Note that S6 is skipped at this time.
- ( ) Connect a wire from S9 (S) to R33 (S).
- ( ) Connect a wire from S10 (S) to the red banana jack (S). Use insulated sleeving over the entire length of this wire.

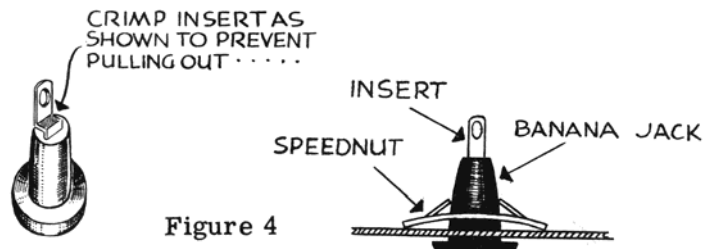
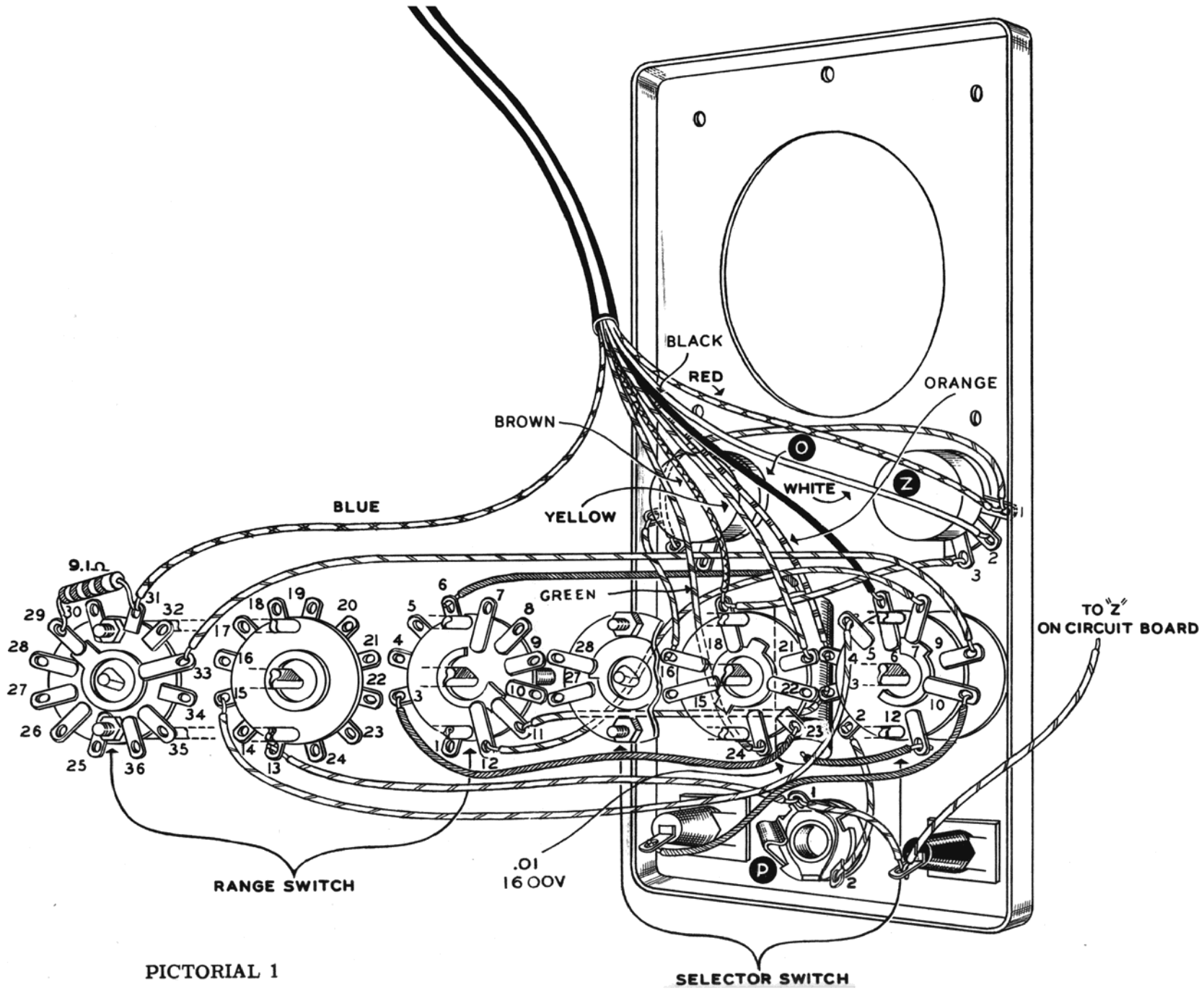

Figure 4



PICTORIAL 1

SELECTOR SWITCH

- ( ) Connect a wire from S23 (NS) to R3 (S). Use insulated sleeving over the entire length of this wire.
- ( ) Connect a wire from R13 (S) to P1 (NS).
- ( ) Connect a wire from P1 (S) to the black banana jack (NS).
- ( ) Connect a 4" length of wire to the black banana jack (S). Leave the other end disconnected for the time being.

**CIRCUIT BOARD ASSEMBLY AND WIRING**

The V-7 VTVM printed circuit board is virtually self-explanatory regarding assembly procedure. The reverse or silk screen side of the board clearly indicates the location of components and cable wiring. However, to minimize the possibility of error and thereby utilize to the fullest extent the advantages offered by printed circuits, the step-by-step procedure as outlined below should be followed.

NOTE: Inspect the circuit board carefully for any obvious defects (broken foil, foil inside of punched holes, etc.) before mounting parts to it.

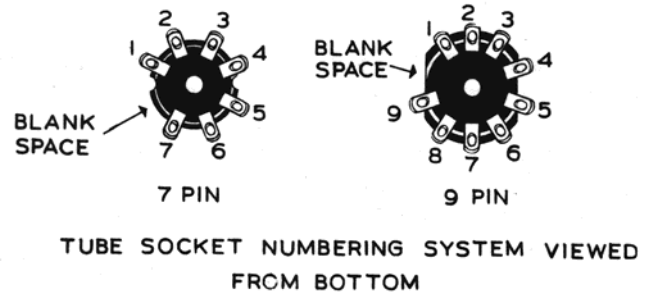

Figure 5

- ( ) Install 7-pin socket through lettered side of the board in the smaller of the two socket locations.

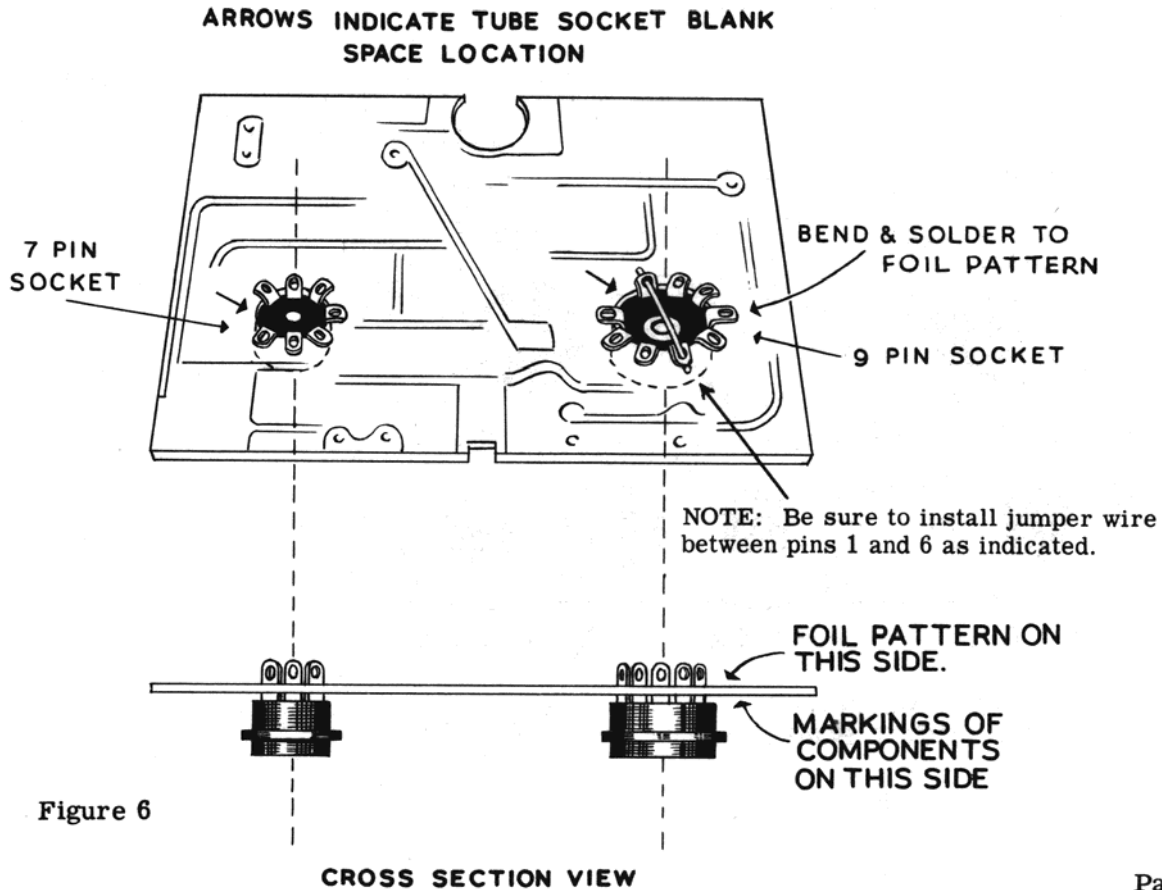

Figure 6

- ( ) Orient the spacing between socket pins 1 and 7 so that it corresponds with the placement shown in Figure 6. With a low wattage small tipped soldering iron, using only rosin core type solder, begin soldering the socket pins to the copper foil terminals. See notes on printed circuit soldering in the INTRODUCTION on Page 3. Note that pin 6 of the 7-pin socket has no circuit connection and soldering only serves to increase mechanical mounting strength.

Please read "Special Note" on Page 31 before proceeding with next step.

- ( ) Install 9-pin socket through lettered side of board. Before soldering socket pins to foil pattern, be sure to connect a wire jumper between pins 1 and 6. Then solder all socket pins to the foil pattern.

#### RESISTORS

- ( ) Install a 3.3 megohm resistor (orange-orange-green) in position designated on the back of the circuit board. Bend the leads at right angles to the resistor body, insert leads in the correct holes and spread leads slightly so the resistor will not drop out of position. Do not solder yet. All of the remaining carbon resistors will be mounted in a similar manner.
- ( ) Install a 220 K $\Omega$  resistor (red-red-yellow) in the position shown on board. Refer to Pictorial 2 for all resistor placement.
- ( ) Install a 150 K $\Omega$  resistor (brown-green-yellow).

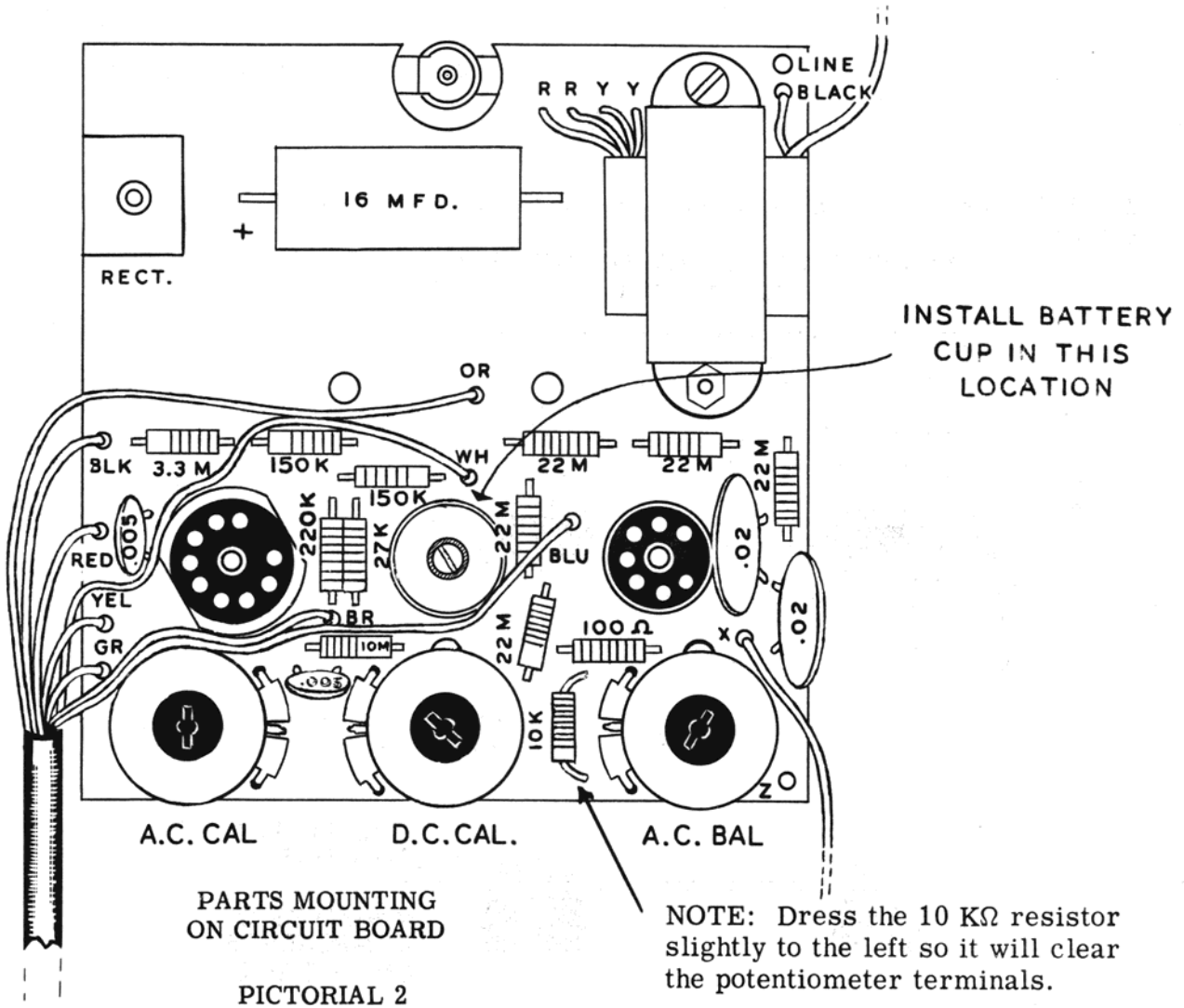

- ( ) Install 27 K $\Omega$  resistor (red-violet-orange).
- ( ) Install 10 megohm resistor (brown-black-blue).
- ( ) Install 150 K $\Omega$  resistor (brown-green-yellow).
- ( ) Install five 22 megohm resistors (red-red-blue) in the five positions shown.
- ( ) Install a 100  $\Omega$  resistor (brown-black-brown).
- ( ) Install a 10 K $\Omega$  resistor (brown-black-orange). Position as shown in Pictorial 2.

Now that the resistors are mounted, check for snug positioning against the circuit board. Then spot solder each lead and trim off close to board surface. Carefully check each connection after clipping to eliminate the presence of a rosin or cold solder joint.

### CONTROLS

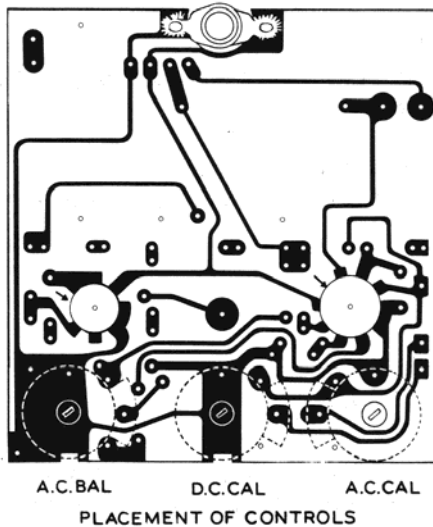

Figure 7

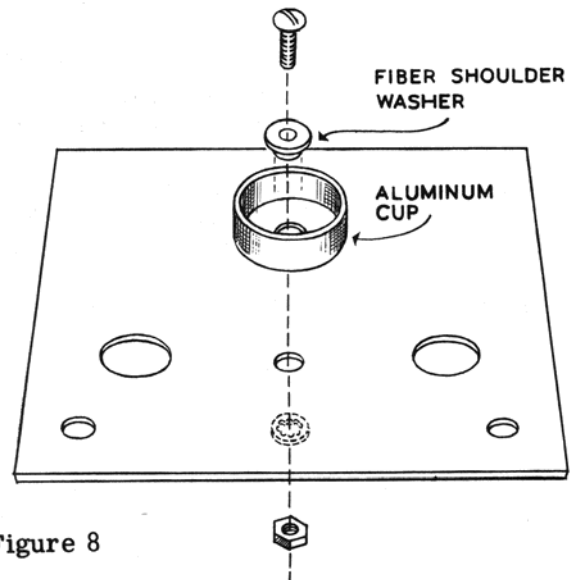

Figure 8

BATTERY CUP MOUNTING ON REVERSE SIDE OF CIRCUIT BOARD

- ( ) Mount the three special type 10 K $\Omega$  controls from the screened side of the board so the mounting lugs and terminals protrude through to the foil side. See Pictorial 2 and Figure 7. Press the controls firmly against the board and solder the mounting lugs and terminals to the foil pattern. One mounting lug of the A. C. CAL. control cannot be soldered to the foil, so bend the lugs slightly inward in order to hold the control securely.

### RECTIFIER - TRANSFORMER - CONDENSERS

- ( ) Mount the selenium rectifier on the reverse side of the circuit board with the terminal lugs protruding through the opening provided. Be sure to note the position of the positive terminals. Bend the lugs over and solder to the circuit board. This will cause one of the lugs to protrude beyond the edge of the circuit board. Clip off the excess portion of this lug so it will be flush with the circuit board edge. This is important, since a short can occur if the lug touches the VTVM case.

- ( ) Mount the power transformer as shown in Pictorial 2. Use 6-32 mounting hardware and note that the 6-32 screw closest to the 6AL5 tube socket is inserted from the etched metal side of the board. This is done to insure adequate clearance for the plastic meter housing when the board is assembled to the instrument.
- ( ) Transformer leads are pre-cut to proper length. Insert leads in their respective, color-coded places and solder leads to the circuit board.
- ( ) Mount the .005  $\mu$ fd condensers in their places as shown in Pictorial 2. Solder leads and trim excess length.
- ( ) Mount both .02  $\mu$ fd condensers in their places as shown in Pictorial 2. Solder leads and trim excess length.
- ( ) Mount the 16  $\mu$ fd filter condenser in the space provided. Be sure to observe polarity with the positive terminal adjacent to the rectifier positive terminal. Solder leads and trim off excess lead length.
- ( ) Mount the pilot light socket in location shown in Pictorial 2. Solder the lugs directly to the circuit. (Bend one lug to an offset position.)

#### CONNECTING CABLE

An 8-wire color-coded cable is used to connect the circuit board to the remaining VTVM circuitry. This cable should be prepared in the following manner.

- ( ) Measure 5" from one end of the cable and carefully remove the cable sheathing by making a circular cut with a small sharp knife and then slipping off the end of the cable sheath. Be careful not to cut into the internal wires.
- ( ) Next cut wires to the following lengths:
 

Green - 1/2"	Brown - 2"
Yellow - 3/4"	White - 3"
Red - 1 1/4"	Blue - 3 1/2"
Black - 1 3/4"	Orange - 4 1/4"
- ( ) Carefully remove about 3/16 insulation from the end of each wire. Twist the fine wire strands tightly and insert the color-coded wires in the openings as shown in Pictorial 2. Solder each wire as it is inserted and clip excess length.
- ( ) Using 6-32 x 3/8" screw and fiber shoulder washer, install battery holder in position shown in Figure 8.
- ( ) Connect one end of a 4" length of hookup wire to point X on board.

The circuit board is now completely assembled and ready for installation in the VTVM.

#### WIRING CIRCUIT BOARD TO PANEL

- ( ) Prepare the 8-wire cable by removing 4" of sheath at the free end. Do not cut the green and blue wires but shorten all others to a length of 3" from the end of the sheath. Again remove about 3/16" of insulation. As a matter of convenience, all wires will be connected to the panel assembly before actually mounting the circuit board.
- ( ) Connect orange wire to S4 (S).
- ( ) Connect black wire to S6 (S).
- ( ) Connect white wire to Z2 (S).
- ( ) Connect red wire to Z1 (S).

PICTORIAL 3

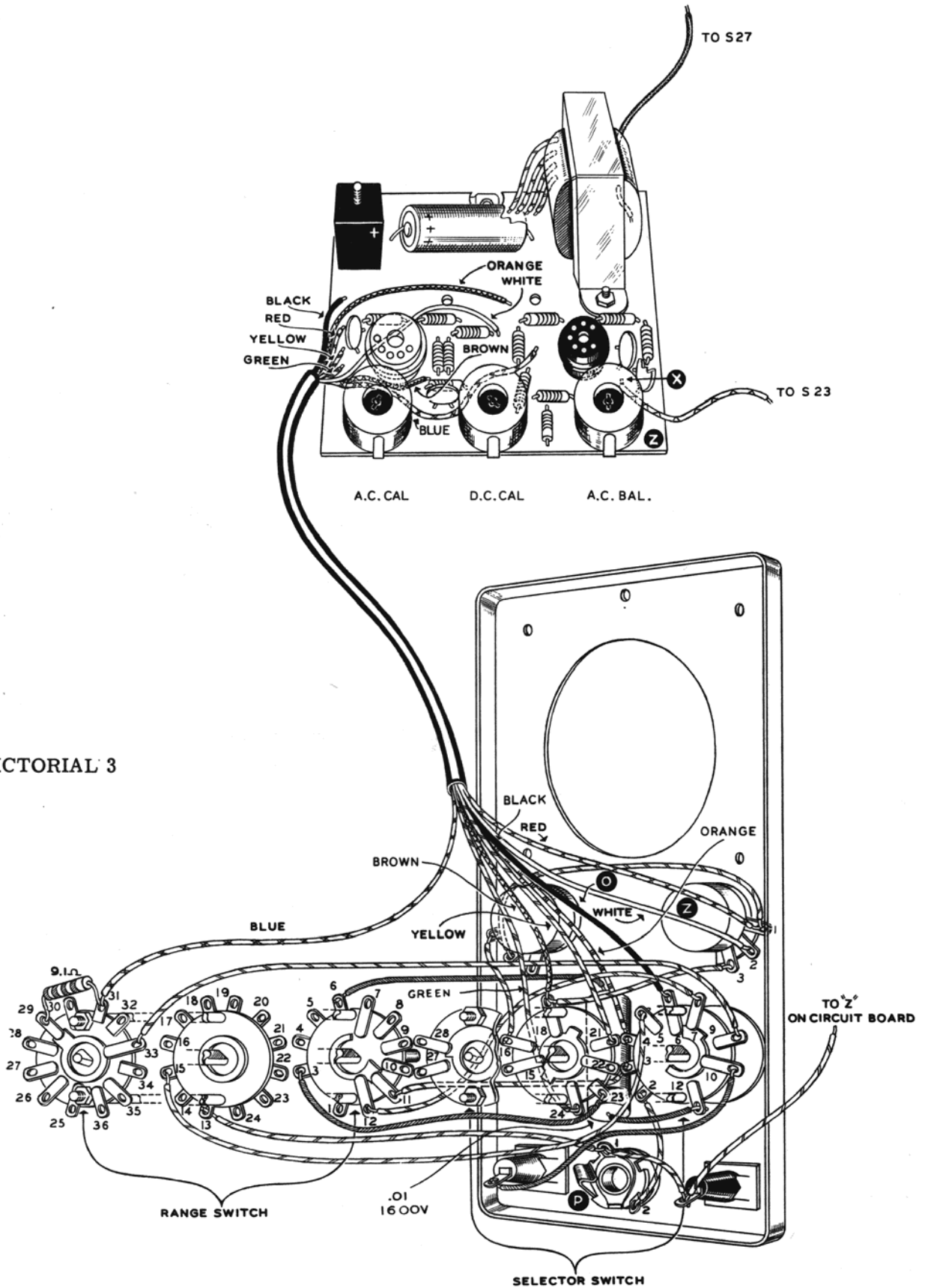

- ( ) Connect brown wire to S18 (S).
- ( ) Connect yellow wire to S21 (S).
- ( ) Connect blue wire to R31 (S).
- ( ) Connect green wire to S24 (S).

#### BRACKET

- ( ) Install rubber line cord grommet in opening provided on bracket.
- ( ) Install phosphor bronze battery holder spring using 6-32 hardware. Install the lockwasher and nut from the lower spiral side of the spring. Long nose pliers are helpful in holding the nut during tightening. See Figure 9.

Figure 9

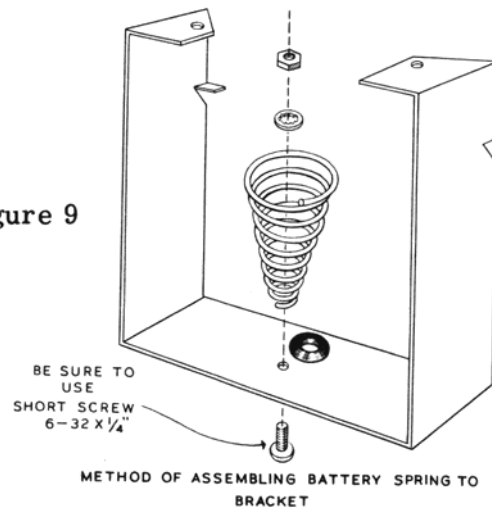

#### METER

Before installing the meter, it is necessary to remove the solder lugs on the meter terminals. On each terminal, hold the lower nut with pliers while loosening the upper nut with a 3/8" socket wrench or another pair of pliers. **DO NOT PERMIT THE STUD TO TURN.** Next, tighten the remaining nuts snugly against the meter stud speed nut. **AGAIN, BE SURE THAT THE STUD IS NOT ROTATED.** While mounting the meter to the panel, be sure to use a soft cloth on your workbench surface.

- ( ) Install meter on panel using only the top two sets of brass hardware. Mount the Z support bracket on the upper right meter stud (when viewed from rear) as shown. Note the off-center piercing of the bracket mounting holes.
- ( ) Install bracket on the two lower meter mounting studs. While tightening the brass 6-32 hardware holding the bracket in place, lightly pinch together the two legs of the bracket. This will insure adequate clearance for the cabinet flange between the panel edge and bracket. Check clearance between bracket and panel control lugs. Bend lugs slightly if necessary. Bracket should straddle 8-wire cable. The notch in each leg of the bracket should be on the side closest to the switches.
- ( ) Install pilot lamp in socket and slip a length of 3/8" diameter sleeving over pilot lamp and socket.
- ( ) Remove 6-32 hardware at the top mounting lug of the transformer on circuit board. Place a #10 fiber washer over each of the two meter terminal studs and then install the circuit board over these same studs. Dress 8-wire cable as shown in Pictorial 4. Install solder lugs and nuts over the studs and tighten firmly but not excessively. Check and adjust alignment of pilot lamp socket with panel opening. Now tighten down the top transformer lug with 6-32 hardware, making sure that the screw passes through the top leg of the Z-bracket.

#### FINAL WIRING

- ( ) Connect remaining short length of hookup wire from location "X" on the chassis board to S23 (S).
- ( ) Connect remaining end of hookup wire from black banana jack to circuit board location Z (S).
- ( ) Connect wire from M1 (positive terminal) (S) to S15 (S).
- ( ) Connect wire from M2 (S) to S22 (S).
- ( ) Insert line cord through rubber grommet at rear of bracket. Tie a simple overhand knot about 6" from the cord end for strain relief.
- ( ) Split line cord and trim 2" from one side. Connect to S28 (S).



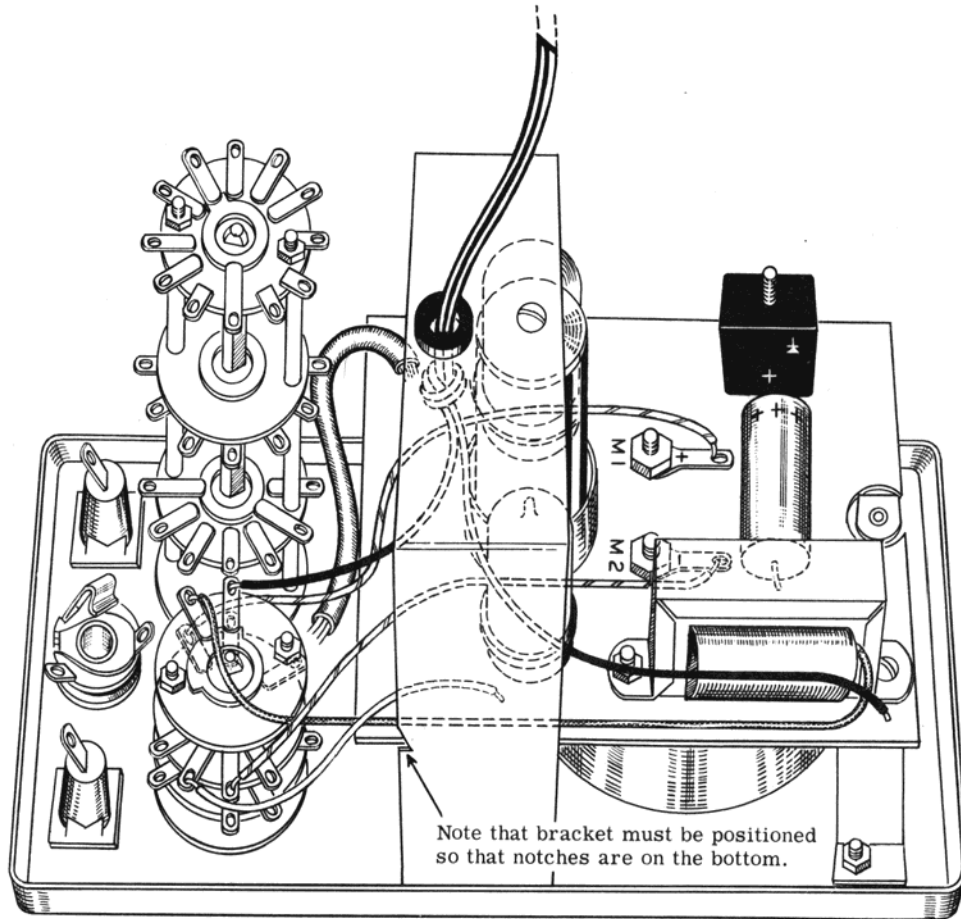

METHOD OF CIRCUIT BOARD INSTALLATION AND DRESS OF 8 WIRE CABLE.

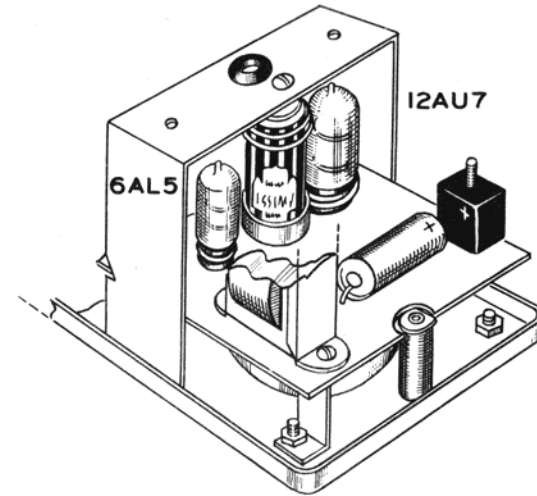

LOCATION OF TUBES AND METHOD OF BATTERY INSTALLATION.

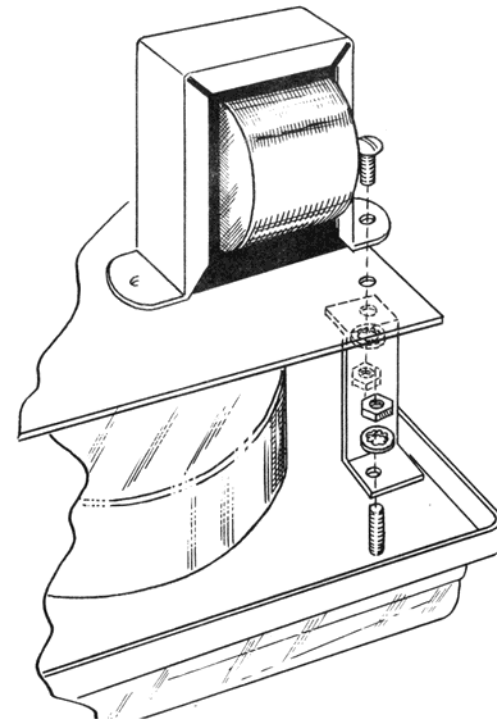

- ( ) Connect remaining line cord wire to "line" on circuit board (S).
- ( ) Connect remaining black transformer wire to S27 (S).

**IMPORTANT WARNING: MINIATURE TUBES CAN BE EASILY DAMAGED WHEN PLUGGING THEM INTO THEIR SOCKETS. THEREFORE, USE EXTREME CARE WHEN INSTALLING THEM. WE DO NOT GUARANTEE OR REPLACE MINIATURE TUBES BROKEN DURING INSTALLATION.**

- ( ) Install tubes in their respective sockets as shown in Pictorial 4. Install dial knobs on control shafts. The two larger knobs being installed on the RANGE and SELECTOR switch shafts while the two smaller knobs are installed on the OHMS ADJUST and ZERO ADJUST control shafts.

Carefully inspect instrument construction and check dress or arrangement of all wiring. Be sure that wiring or components are not positioned in such a manner that short circuits may occur. Check all solder points to make sure that necessary solder connections have been made. Shake out all loose wire cuttings, insulation and other debris that may have accumulated during the assembly of the instrument.

#### PRELIMINARY TEST

Plug the VTVM line cord into a 117 volt 60 cycle AC source. Do not attempt to use the instrument on DC or 25 cycle supply as serious damage will result. Switch the selector knob to the DC+ or DC- position and the range switch to the 1 1/2 volt position. The tubes and pilot light should light. Within 15 or 20 seconds of warmup time, there should be some degree of zero adjust control action, which will permit the meter pointer to deflect over a limited range of the dial. During the preliminary warmup assembly, check the instrument assembly very carefully for any indication of overheating which would result from errors in construction. Assuming that the instrument will respond in the manner indicated, it will be safe to leave it turned on to thoroughly warm up while the balance of the kit project is completed. This will consist of test lead preparation and cabinet assembly. Refer to Figure 10 and large fold-in for test lead preparation.

#### PREPARATION OF TEST LEADS

Figure 10

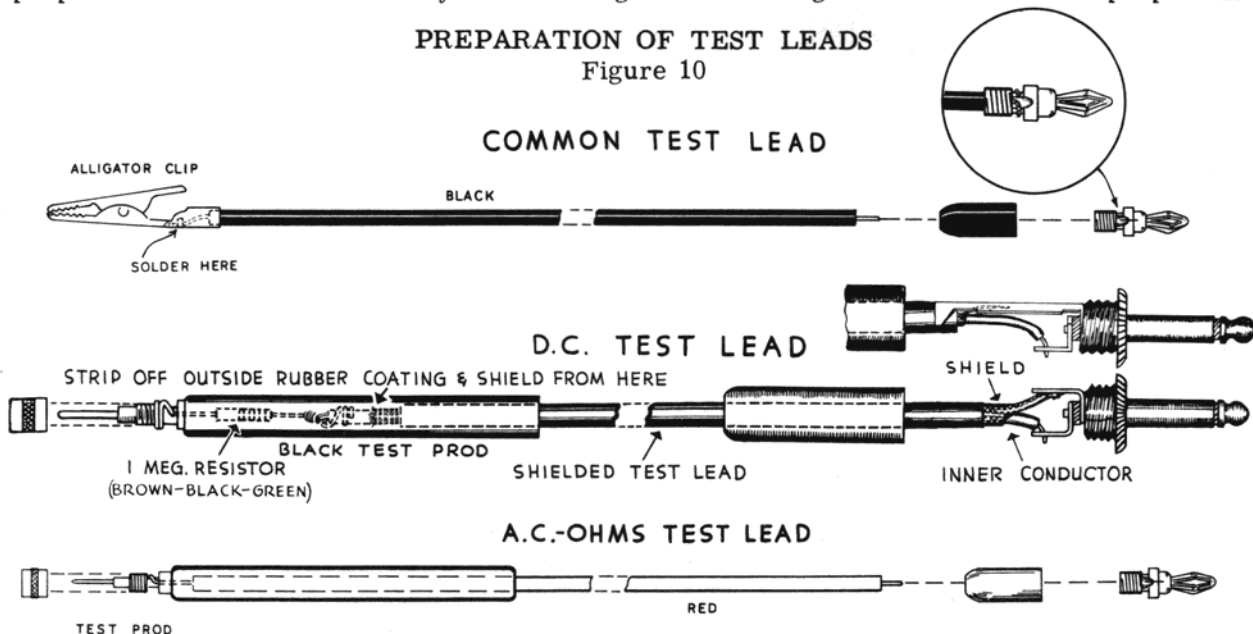

- ( ) **COMMON TEST LEAD:** The common test lead is made by connecting the black banana plug on one end of the black test lead and an alligator clip on the other. Figure 10 shows the detail. The banana plug is assembled by slipping the black insulator sleeve over the black lead. Insert the stripped wire into the plug and wrap once around the plug as shown. Screw the sleeve onto the plug securely. No solder is required.

- ( ) **DC TEST LEAD:** The DC test lead is made by connecting the phone plug on one end of the shielded test lead, the inner wire conductor to the phone plug tip connection and the wire shield to the phone plug sleeve. On the other end, goes a small 1 megohm resistor which is then slipped inside the black test prod. See Figure 10. It is important that the shield portion of the test lead at the resistor end does not touch the resistor or solder connection. Do not connect the shield to anything at this point. The only shield connection used is made at the phone plug end. After soldering the resistor to the inner conductor of the test lead, do not wrap the joint with tape of any kind as this could cause a high resistance leakage path across the shield portion and the resistor lead resulting in measurement inaccuracies.
- ( ) **AC-OHMS TEST LEAD:** The AC ohms test lead is made by connecting the red banana plug on one end of the red test lead and the red test prod on the other. Figure 10 shows the construction.
- ( ) Fasten the handle on the case, using two 10-24 screws.
- ( ) Push the rubber feet into the four holes in the bottom of the VTVM case.



### TEST AND CALIBRATION

During the preparation of the test leads and cabinet, the VTVM has had an opportunity to warm up thoroughly and should now be calibrated.

Turn the instrument off and make sure that the mechanical zero position of the meter pointer is correct. If not, adjust as follows:

Place the instrument in normal operating position. Turn the black plastic screw on the meter face with a screwdriver while gently tapping the meter face with one finger until the pointer coincides with the zero line on the left side of the scale. Turn the instrument on again.

- ( ) Set the SELECTOR switch to DC+. Check operation of the zero adjust control. Turning this control should move the meter pointer part way up scale. Set pointer to zero at the left side of the scale and check for zero positioning when the SELECTOR switch is changed to DC-. It should be possible to obtain a zero adjust control position that will permit the meter pointer to remain stationary when switching through from DC+ to DC-. If there is an appreciable zero shift of more than two divisions on the scale, it should be regarded merely as an indication that additional aging of the 12AU7 tube is required. This aging can be obtained by leaving the instrument turned on for a period of 48 hours or more, or through continued use of the VTVM with periodic calibration.

#### DC CALIBRATE:

Insert the common and DC test leads. Set the SELECTOR switch to DC+ and the RANGE switch to 1.5 volts. Connect the test leads to the calibrated flashlight cell and adjust the DC CALIBRATE control so that the meter pointer falls directly over the very small red dot on the meter face. Approach the red dot going up scale by turning the screwdriver calibrate control and watch the meter read 1.4 volts and 1.5 volts and then the red dot. As soon as the red dot is reached, stop turning the DC CALIBRATE control. Remember that the range switch must be set on 1.5 volts for this adjustment.

#### OHMS CHECK:

Turn off VTVM. To install the battery, start top (+) end of the battery into the battery cup and then pull the spring out and over the bottom (-) end of the battery. Now push the spring and the battery in under the metal brace so the spring, battery and battery cup are all in line. Turn on VTVM and set SELECTOR switch to OHMS. Set OHMS ADJUST for full scale (infinity). Insert AC-OHMS test lead and touch probe to common test clip. Meter pointer should drop to zero at left end of scale (no resistance).

#### AC CALIBRATE:

Temporarily remove AC OHMS test lead. Set RANGE switch to 1.5 volts and SELECTOR switch to AC. Adjust AC BALANCE control so no movement is noticed in the pointer when switching from AC through DC- to DC+. Now set RANGE switch to 150 volts and the SELECTOR switch to AC. Reinsert AC ohms lead. Connect AC ohms and common lead to the 117 volt AC line.

WARNING: 117 volt AC line is dangerous. Proceed with due care.

Adjust AC CALIBRATE control until pointer indicates the line voltage (117 volts AC).

#### AGING

It is recommended that the tubes be aged before final calibration. This is accomplished by keeping the instrument turned on for a period of at least 48 hours. Final calibration should be done in the same way as the initial calibration. Careful calibration will result in a more accurate instrument. If a standard AC meter is available, it is desirable to use such an instrument preferably at a voltage near full scale on the VTVM as for instance, 140 volts or 40 volts on the 150 volt or 50 volt range respectively.

One of the major advantages of kit form instrument construction is that the kit builder becomes thoroughly familiarized with calibration procedure and is therefore in an excellent position to periodically check VTVM operating accuracy instead of assuming that usual factory instrument calibration is still valid.

Please bear in mind that any fresh stock flashlight battery will actually measure 1.55 volts and can be used for calibrating purposes. The battery supplied with your VTVM was individually checked for proper voltage and marked accordingly as a precautionary measure. It is evident that it will not be necessary for the kit purchaser to obtain a specially calibrated battery from the Heath Company when battery replacement is required. Any standard brand fresh stock battery will serve the purpose.

After final calibration, place the instrument in the cabinet and install the two #6 sheet metal screws through the back and into the bracket. The instrument is now ready for use. The power consumption of the VTVM is very low and there is no objection to leaving the instrument on continuously during the daily work period rather than turning it off each time a measurement function is completed. Daily operation for a period of several hours or more will also serve the purpose of eliminating possible moisture accumulation.

#### IN CASE OF DIFFICULTY

In event the instrument does not perform properly and calibration procedure cannot be obtained in the manner described, we would suggest that you observe the following check procedure.

1. Recheck all wiring to the RANGE and SELECTOR switches and make sure that all connections are properly made. Most cases of trouble result from improper or reversed connections. Often having a friend check the wiring will reveal a mistake that is consistently overlooked.
2. Check the 6AL5 and 12AU7 tubes. If possible, check tube performance in the VTVM circuit by substitution with tubes known to be in good operating condition. Tubes used in this VTVM do not require special selection and their replacement should not present a problem.
3. If the meter pointer swings full scale to the right and stays there with SELECTOR switch at DC+, check for an open circuit or high resistance connection somewhere between the grid pin 2 of the 12AU7 tube and ground. This condition might be due to a wrong connection to the SELECTOR switch, a poor connection or possibly an open resistor.

If the instrument does not operate on any function, a check of the power supply, the 12AU7 tube and its associated meter circuit is suggested.

If the instrument fails to function on AC measurements only, then a check of the 6AL5 and its associated circuits should be made.

If the instrument only fails to function on ohms, the difficulty will probably be due to the battery (make certain the battery is making good contact in the bracket) or the ohms multiplier resistor string. If the resistor string is open at some point, the meter pointer will usually deflect to the extreme right of the meter scale, regardless of the setting of the ohms adjust control.

It is important that proper operation on DC+ or DC- should first be obtained before any attempt is made to use the instrument on AC or ohms.

4. Check the operating voltages. The following voltages are measured to chassis. Pins 1 or 6 of the 12AU7 tube or positive lug on the rectifier, 50-70 volts positive. Negative side of filter condenser, 60-85 volts negative.
5. Check continuity through the DC test cable. Make certain that the shielding is not shorted to the center conductor or that the 1 megohm isolating resistor inside the test prod is not being grounded.
6. Insufficient range of zero adjust control could indicate that possibly the wire jumper between pins 1 and 6 of the 12AU7 tube has been omitted.
7. Visually inspect all construction to determine the possibility of wire cuttings or blobs of solder being lodged against control terminals, switch contacts, etc.

NOTE: If circuit board is accidentally damaged by dropping, resulting in cracks in the laminate, the following precautions should be observed. A break in the board will almost always cause a corresponding break in the foil pattern. In event this should occur, the foil pattern can be easily repaired by bridging the foil break with a short length of bare wire. Just lay the wire right on the pattern, bend to fit foil contours if necessary, and then solder the full length of the wire.

Alternately flexing each corner of the board slightly while the instrument is in operation will usually reveal whether or not a foil pattern break is present as the instrument will react in an erratic manner.

The circuit board used in your VTVM is rugged and serviceable and under normal conditions of usage, the board does not require unusual handling precautions. However, the information supplied will be helpful in the event an accident should occur.

#### REPLACEMENTS

Material supplied with Heathkits has been carefully selected to meet design requirements and ordinarily will fulfill its function without difficulty. Occasionally improper instrument operation can be traced to a faulty tube or component. Should inspection reveal the necessity for replacement, write to the Heath Company and supply all of the following information.

- A. Thoroughly identify the part in question by using the part number and description found in the manual parts list.
- B. Identify the type and model number of kit in which it is used.
- C. Mention the order number and date of purchase.
- D. Describe the nature of defect or reason for requesting replacements.

The Heath Company will promptly supply the necessary replacement. Please do not return the original component until specifically requested to do so. Do not dismantle the component in question as this will void the guarantee. If tubes are to be returned, pack them carefully to prevent breakage in shipment as broken tubes are not eligible for replacement. This replacement policy does not cover the free replacement of parts that may have been broken or damaged through carelessness on the part of the kit builder.

## SERVICE

In event continued operational difficulties of the completed instrument are experienced, the facilities of the Heath Company Service Department are at your disposal. Your instrument may be returned for inspection and repair for a service charge of \$4.00, plus the price of any additional material that may be required. **THIS SERVICE POLICY APPLIES ONLY TO COMPLETED INSTRUMENTS CONSTRUCTED IN ACCORDANCE WITH THE INSTRUCTIONS AS STATED IN THE MANUAL.** Instruments that are not entirely completed or instruments that are modified in design will not be accepted for repair. Instruments showing evidence of acid core solder or paste fluxes will be returned not repaired.

The Heath Company is willing to offer its full cooperation to assist you in obtaining the proper operation of your instrument and therefore this factory repair service is available to you, or you may contact our Technical Consultation Department by mail.

**NOTE:** In the event the circuit board in your VTVM has been ruined through accidental use of acid or paste fluxes, a convenient repair kit is available.

This kit will consist of a new circuit board, 7-pin and 9-pin sockets, all board mounted resistors and disc ceramic condensers. The selenium rectifier, battery cup, controls, filter condenser and power transformer can be salvaged with little difficulty.

In event the RANGE and SELECTOR switches have also been damaged, replacements can be purchased from the Heath Company.

Circuit Board Repair Kit, #R-V-7A ... \$3.00  
Range Switch, #63-79..... \$2.25  
Selector Switch, #63-80..... \$2.00

## SHIPPING INSTRUCTIONS

Before returning a unit for service, be sure that all parts are securely mounted.

**ATTACH A TAG TO THE INSTRUMENT GIVING  
NAME, ADDRESS AND TROUBLE EXPERIENCED.**

Pack in a rugged container, preferably wood, using at least three inches of shredded newspaper or excelsior on all sides. **DO NOT SHIP IN THE ORIGINAL KIT CARTON AS THIS CARTON IS NOT CONSIDERED ADEQUATE FOR SAFE SHIPMENT OF THE COMPLETED INSTRUMENT.** Ship by prepaid express if possible. Return shipment will be made by express collect. Note that a carrier cannot be held liable for damage in transit if packing, in HIS OPINION, is insufficient.

All prices are subject to change without notice. The Heath Company reserves the right to discontinue instruments and to change specifications at any time without incurring any obligation to incorporate new features in instruments previously sold.

## WARRANTY

Heath Company warrants that for a period of three months from the date of shipment, all Heathkit parts shall be free of defects in materials and workmanship under normal use and service and that in fulfillment of any breach of such warranty, Heath Company shall replace such defective parts upon the return of the same to its factory. The foregoing warranty shall apply only to the original buyer, and is and shall be in lieu of all other warranties, whether express or implied and of all other obligations or liabilities on the part of Heath Company and in no event shall Heath Company be liable for any anticipated profits, consequential damages, loss of time or other losses incurred by the buyer in connection with the purchase, assembly or operation of Heathkits or components thereof. No replacement shall be made of parts damaged by the buyer in the course of handling or assembling Heathkit equipment.

**NOTE:** The foregoing warranty is completely void and we will not replace, repair or service instruments or parts thereof in which acid core solder or paste fluxes have been used.

## PARTS LIST

PART No.	PARTS Per Kit	DESCRIPTION	PART No.	PARTS Per Kit	DESCRIPTION
<b>Resistors</b>			<b>Wire-Grommets</b>		
2-48	1	9.1 $\Omega$ carbon	89-1	1	Line cord
1-3	1	100 $\Omega$ carbon	340-2	1	length Bare wire
1-20	1	10 K $\Omega$ carbon	341-1	1	length Black test lead
1-23	1	27 K $\Omega$ carbon	341-2	1	length Red test lead
1-27	2	150 K $\Omega$ carbon	343-3	1	length Shielded test lead
1-29	1	220 K $\Omega$ carbon	344-1	1	roll Hookup wire
1-35	1	1 megohm carbon	346-1	1	length Spaghetti (sleeving)
1-38	1	3.3 megohm carbon	346-6	1	length 3/8" fiberglass sleeving
1-40	1	10 megohm carbon	347-1	1	length 8-wire cable
1-70	5	22 megohm carbon	73-1	1	3/8 rubber grommet
2-24	1	90 $\Omega$ precision	<b>Sheet Metal Parts</b>		
2-29	1	900 $\Omega$ precision	90-17	1	Cabinet and rear cover
2-35	1	9 K $\Omega$ precision	203-61F258	1	Front panel
2-50	1	10 K $\Omega$ precision	204-M69	1	Bracket assembly
2-38	1	20 K $\Omega$ precision	214-2	1	Battery housing cup
2-9	1	70 K $\Omega$ precision	204-M84	1	Z support bracket
2-41	1	90 K $\Omega$ precision	<b>Hardware</b>		
2-86	1	150 K $\Omega$ precision	250-8	2	#6 x 3/8 sheet metal screw
2-54	1	200 K $\Omega$ precision	250-9	3	6-32 x 3/8 screw
2-87	1	320 K $\Omega$ precision	250-83	2	#10 x 1/2" handle screw
2-13	1	700 K $\Omega$ precision	250-31	1	6-32 x 1/4 screw
2-51	1	900 K $\Omega$ precision	252-3	4	6-32 nut
2-55	1	2 megohm precision	252-7	5	Control nut
2-16	1	7 megohm precision	252-9	2	Speednut, jack
2-52	1	9 megohm precision	253-2	1	#6 fiber shoulder washer
2-28A	1	900 K $\Omega$ 1 watt precision	253-10	5	Control nickel washer
<b>Condensers</b>			254-1	4	Lockwasher
21-27	2	.005 400 v. disc ceramic	254-4	5	Control lockwasher
21-31	2	.02 400 v. disc ceramic	253-3	2	#10 flat fiber washer
23-60	1	.01 1600 volt tubular	<b>Miscellaneous</b>		
25-5	1	16 $\mu$ fd 150 v.	54-23	1	Power transformer
<b>Controls-Switches</b>			57-13	1	Selenium rectifier
10-8	2	10 K $\Omega$ control	70-5	1	Banana plug insulator, black
10-38	3	10 K $\Omega$ control	70-6	1	Banana plug insulator, red
63-79	1	RANGE switch	85-9F102	1	Circuit board, complete
63-80	1	SELECTOR switch	211-4	1	Handle
<b>Tubes-Lamps</b>			258-7	1	Spring, phosphor bronze
411-25	1	12AU7 tube	260-1	1	Alligator clip
411-40	1	6AL5 tube	407-62	1	200 microamp meter
412-4	1	#50 pilot lamp	418-1	1	Flashlight cell
<b>Sockets-Knobs-Feet</b>			436-1	1	Phone jack
434-59	1	7-pin socket	436-2	1	Banana jack, black
434-60	1	9-pin socket	436-3	1	Banana jack, red
434-47	1	Pilot light socket	437-1	2	Banana jack insert
462-19	2	Skirt knobs	438-3	1	Phone plug
462-30	2	Knobs, small	438-13	2	Banana plug assembly
261-1	4	Rubber feet	439-1	1	Red test prod
			439-2	1	Black test prod
			595-110	1	Manual

## CIRCUIT DESCRIPTION

The Heathkit model V-7A VTVM is intended for use by service men, engineers and maintenance men to make accurate measurements of DC+, DC-, AC RMS values, peak-to-peak values and resistance measurements. Its usefulness is in the measurement of voltages and resistance in radio and TV work, laboratory usage and any application requiring the rapid, accurate measurement of electrical functions. The design is simple yet rugged with complete versatility in combining the functions of many instruments in one.

This instrument employs vacuum tubes in all measurement functions to insure good sensitivity and stability.

The sensitive 200 microamp meter movement is placed in the cathode circuit of a 12AU7 twin triode. The zero adjust control sets up a balance between the two sections of the triode such that with the zero input voltage applied to the first grid, the voltage drop across each portion of the adjust control (from adjust arm to one side and adjust arm to the other side) is the same. This being true, the meter reads zero. With a voltage applied to the first grid, the balance in the cathode circuits is upset and the meter indicates. The relationship between the test voltage applied to the first grid and the meter indicating current is linear and therefore the meter is calibrated with a linear scale. The advantage of having the meter in a vacuum tube circuit of this kind is that the voltages to be measured are not applied directly to the meter but rather to the tube. Because the tube is limited to the amount of current it can draw, the meter movement is electronically protected.

The maximum test voltage which is applied to the 12AU7 tube is about 3 volts. Higher test voltages are reduced by a voltage divider which has a total resistance of 10 megohms. An additional resistance of 1 megohm is located in the DC test prod thereby permitting measurements to be made in circuits carrying RF with a minimum disturbance of such circuits.

On AC measurement functions, a 6AL5 duo-diode is used as a half-wave doubler to provide a DC voltage proportional to the peak-to-peak value of the applied AC voltage. This DC voltage is applied through the voltage divider string to the tube causing the meter to indicate in the manner previously described. The AC voltage scales are calibrated in both RMS and peak-to-peak values. In the 1.5, 5, 15, 50 and 150 volt positions of the range switch, the full AC voltage being measured is applied to the input of the 6AL5 half-wave doubler. On the 500 and 1500 volt positions of the range switch, a divider network reduces the applied voltage in order to limit the voltage input to the 6AL5 to a safe recommended level. Under normal conditions of usage, it is not possible for voltages in excess of 150 volts to be applied to the 6AL5. This design feature further protects the tube and its associated circuits. CAUTION: Accidentally applying AC voltage in excess of 400 volts with the RANGE switch set at 150 volts or lower, will invariably ruin the 6AL5 tube. Always use a higher voltage range and then switch down to a near full scale range.

The AC calibrate control is used so as to obtain the proper meter deflection for the applied AC voltage. Vacuum tubes develop a contact potential between tube elements. Such contact potential developed into the diode would cause a slight voltage to be present at all times. This voltage is cancelled out by proper application of a bucking voltage. The amount of bucking voltage is controlled by the AC balance control. This eliminates zero shift when switching from AC to DC.

For resistance measurements, a 1.5 volt battery is connected through a string of multipliers and the external resistance to be tested, thus forming a voltage divider across the battery. A resultant portion of the battery voltage is applied to the twin triode. The meter scale is calibrated in resistance for this function.

## USING THE VTVM

The VTVM has many advantages over the non-electronic volt-ohmmeters. The greatest advantage is the high input resistance. This enables much more accurate readings to be obtained in high impedance circuits such as resistance coupled amplifiers, oscillator grid circuits and AVC networks.



To illustrate this, let us assume a resistance coupled audio amplifier with a .5 megohm plate load resistor operating from a 100 volt plate supply. Let us assume that the tube acts as a .5 megohm resistor. Measuring the plate voltage with a conventional 1000 ohm per volt instrument on the 100 volt scale, the meter can be considered a 100,000 ohm (.1 megohm) resistor in parallel with the tube. The voltage on the plate is then about 14 volts and is shown as such by the meter. This is due to the shunt resistance of the low resistance meter. Using the VTVM on any scale setting, the full 11 megohms is placed in parallel with the tube. The voltage on the plate is then about 49 volts or 2% lower than the normal operating voltage. Thus accurate reading can be obtained only with the high resistance provided by a VTVM.

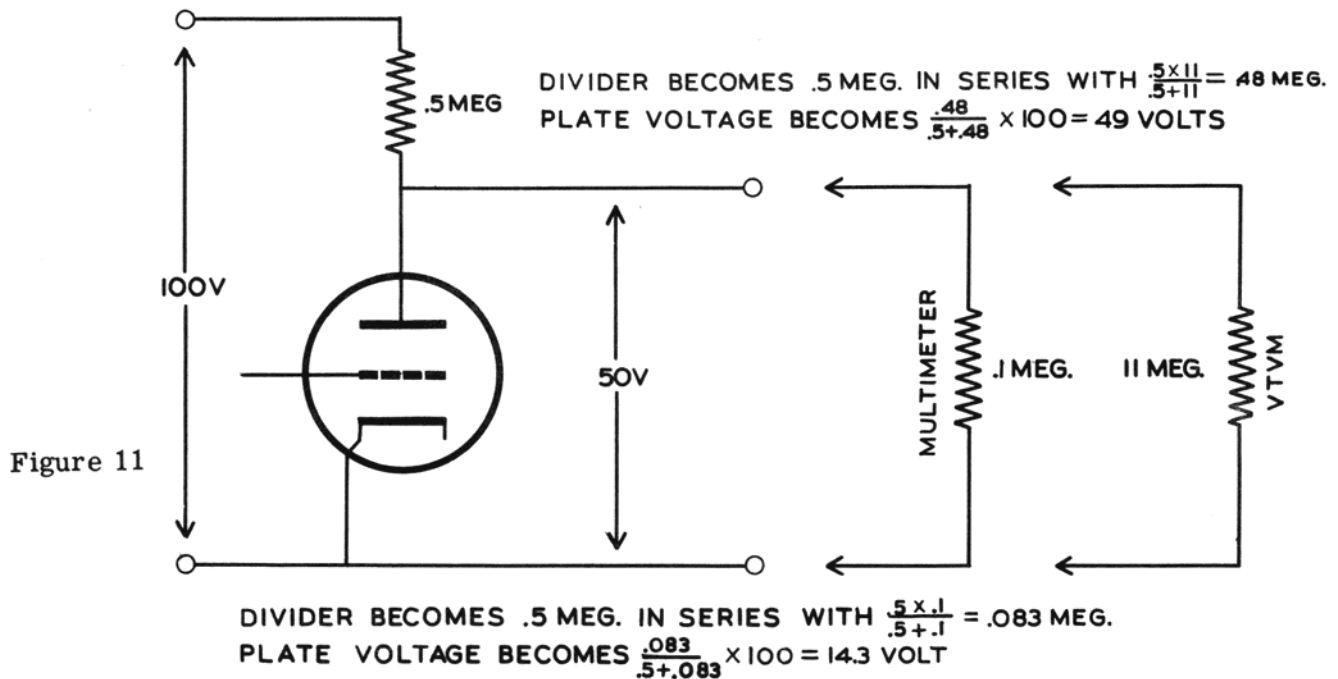

#### DC VOLTAGE MEASUREMENTS

To measure DC voltage with the VTVM, connect the common (black lead) to the common or "cold" side of the voltage to be measured. Set the selector switch to DC+ or DC- as required and set the range switch to a range greater than the voltage to be measured, if known. If unknown, set to 1500 volts. With black test prod, touch other or "hot" side of the voltage to be measured. If the pointer moves less than 1/3 of full scale, switch the range switch to the next lower range. For greatest measurement accuracy, all voltage measurements should be made on a range position which permits at least 1/2 or 2/3 scale deflection of the meter pointer.

The voltage ranges selected for the VTVM are intended to provide convenient coverage for the radio and TV service man. For example, the 1.5 volt range will be useful in measuring bias voltages, DC heater voltages, etc. The 5 and 15 volt ranges will again prove their worth in bias measurement functions. The 50 and 150 volt ranges will find greatest application in the measurement of voltages encountered in universal or transformerless type radio circuits. The 500 volt range can be used on conventional transformer operated power supplies found in radio and TV circuits and this voltage range eliminates the necessity for switching from one range to another when measuring plate and screen supply voltages. On many occasions, the higher voltage ranges will prove useful.

DC accelerating potentials developed in TV receiver flyback power supply systems can be safely measured through the use of the Heathkit High Voltage Probe, in conjunction with the VTVM. This probe with its precision multiplier resistor mounted in a safety plastic probe housing will provide a multiplication factor of 100 for the VTVM DC ranges. 30,000 volts DC is generally considered the safe upper limit for these measurements.

## AC VOLTAGE MEASUREMENTS

To measure AC voltage with the VTVM, connect the common (black) lead to the common or "cold" side of the voltage to be measured. Set the selector switch to AC and set the range switch to a range greater than the voltage to be measured if known. If unknown, set to 1500 volts. With the red test prod, touch the other side or "hot" side of the voltage to be measured. If the meter moves less than 1/3 of full scale, switch to the next lower range. The maximum AC voltage that can be safely measured with your VTVM is 1500 volts, and this limit must not be exceeded. The meter scales of the V-7A are calibrated in both RMS and peak-to-peak voltages. When values of sine waves are measured, RMS voltages are read and the corresponding values in peak-to-peak volts are equal to 2.83 times the RMS voltage. If the range switch is set at 15 volts and a sine wave of 10 RMS volts is applied to the instrument, the meter pointer will indicate 10 RMS volts and 28.3 peak-to-peak volts. This direct-reading time-saving feature makes the usual calculation to transpose from one scale to another unnecessary.

The Heathkit VTVM is an extremely sensitive electronic AC voltmeter and as the human body picks up AC when near any AC wires, the meter will indicate this pickup. Never touch the AC prod when on the lower ranges. Zero should be set with the AC prod shorted to the common clip. Because of this characteristic of extreme sensitivity, it is possible that the accuracy of AC measurements on the 1.5 volt scale only may vary as much as 15% and this possible deviation should be taken into consideration. On the remaining ranges, the accuracy should be well within the 5% specified.

**CAUTION:** It is good practice to observe certain basic rules of operating procedure anytime voltage measurements are to be made. Always handle the test prods by the insulated housing only and do not touch the exposed or tip portion. The metal case of this instrument is connected to the ground of the internal circuit and for proper operation, the ground terminal of the instrument should always be connected to the ground of the equipment under test. There is always danger inherent in testing electrical equipment and therefore the user should clearly familiarize himself with the equipment under test before working on it, bearing in mind that high voltages may appear at unexpected points in defective equipment.

When measurements are to be made at high voltage points, it is good practice to remove operating power before connecting test leads. If this is not possible, be particularly careful to avoid accidental contact with nearby objects which could provide a ground return path. When working on high voltage circuits, play safe, keep one hand in your pocket to minimize accidental shock hazard and be sure to stand on a properly insulated floor or floor covering.

Voltages encountered in the measurement range of this instrument are seldom lethal in nature but the secondary effects can be quite serious; such as involuntary reaction causing a fall or bodily injury as an indirect result of shock hazard.

## RESISTANCE MEASUREMENTS

To measure resistance with the VTVM, connect the common (black) lead to one side of the resistor or circuit to be measured. Set the selector to ohms and set the range switch to such a range that the reading will fall as near midscale as possible. Set the ohms adjust control so the meter indicates exactly full scale (infinity on ohms scale). Then touch the red test prod to the other side of the resistor or circuit to be measured. Read resistance on ohms scale and multiply by the proper factor as shown by the range switch settings.

**NOTE:** Although a battery is used to measure resistance, the indication is obtained through the electronic meter circuit and therefore the VTVM must be connected to the AC power line and turned on. Establish the habit of never leaving the instrument set in the ohms position as this could greatly shorten the life of the ohmmeter battery particularly if the test leads are accidentally shorted together when lying on the service bench.

## USING THE VTVM DECIBEL SCALE

Because the human ear does not respond to volume of sound in proportion to signal strength, a unit of measure called the "bel" was adopted. The bel is more nearly equivalent to human ratios. Normally the reading is given in 1/10 of a bel or a decibel. Various signal levels are adopted by various manufacturers as standard of zero decibel. The Heathkit VTVM DB scale (decibel) uses a standard of 1 milliwatt into a 600 ohm line as zero decibels. This corresponds to .774 volts AC on the 0-1.5 volt scale. From this figure, the various AC ranges of the VTVM may be converted to DB, with adequate accuracy, by the following chart:

AC VOLTS SCALE	DECIBEL SCALE
0-1.5 volts	Read db directly
0-5 volts	Add 10 db to the reading
0-15 volts	Add 20 db to the reading
0-50 volts	Add 30 db to the reading
0-150 volts	Add 40 db to the reading
0-500 volts	Add 50 db to the reading
0-1500 volts	Add 60 db to the reading

As the decibel is a power ratio or voltage ratio, it may be used as such without specifying the reference level. Thus for instance, a fidelity curve may be run on an amplifier by feeding in a signal of variable frequency but constant amplitude. At a reference frequency of say 400 cycles, adjust input to give a convenient indication (zero db for instance) on the VTVM connected to the output. As the input frequency is varied, the output variation may be noted directly in DB above and below the specified reference level. **NOTE:** When measuring complex AC wave shapes, such as ripple, hum, distorted and square waves, the indication is 35% peak-to-peak.

### READING THE METER SCALE

The voltage markings on the RANGE switch refer to the full scale reading. The scale is marked 0-15 and 0-50 for voltage. On the 1.5 volt range, read the 0-15 scale and move the decimal one place to the left. Thus for example, a reading of 8 would represent a voltage of .8 volts. On the 5 volt range, read the 0-50 scale and move the decimal point 1 place to the left, that is, drop the zero. A reading of 40 volts would represent a voltage of 4 volts. On the 15 volt range, read the 0-15 scale directly. **EXAMPLE:** A reading of 4 volts represents a voltage of 4 volts. On the 50 volt range, read the 0-50 volts directly. On the 150 volt range, read the 0-15 scale and add one zero. **EXAMPLE:** A reading of 12 represents a voltage of 120 volts. On the 500 volt range, read the 0-50 scale and add one zero. **EXAMPLE:** A reading of 40 represents a voltage of 400 volts. On the 1500 volt range, read the 0-15 scale and add two zeros. **EXAMPLE:** A reading of 8 represents a voltage of 800 volts.

**NOTE:** This marking does not mean that the upper scale indicates DCV and the lower scale ACV. Rather it means that either scale will read ACV or DCV depending on the setting of the SELECTOR switch.

The resistance marking or ohms scale refers to the lowest resistance range "RX1." For the other ranges, add the proper number of zeros. Add two zeros for RX100, four zeros for RX10K and six zeros for RX1 MEG. On the RX1 MEG range, the scale can also be considered to read directly in megohms.

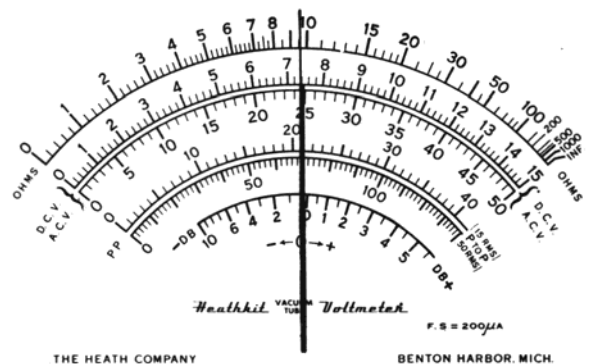

### ACCURACY

The accuracy of the meter movement is within 2% of full scale which means that on the 1000 volt range, for instance, the accuracy of the movement will be within 20 volts at any point on the scale. On DC, the accuracy of the multiplier 1% may be additive resulting in an inaccuracy of within 3% of full scale.

Figure 12

On AC, the accuracy of the rectifier circuit contributes variations which result in accuracy of within 5% of full scale. Bear in mind that on the lowest AC voltage range the 1.5 volt full scale, extreme sensitivity will introduce additional variation through stray pickup. Therefore, on the 1.5 volt range, it is possible that the accuracy may be in the order of 15% on AC only.

The accuracy on the ohms range depends on the meter accuracy, the ohms multiplier accuracy (including the internal resistance of the batteries) and the stability of the battery voltage. On the RX1 scale, the internal resistance of the batteries and the battery voltage both vary as a result of the current drawn by the resistance under test. For greatest accuracy, tests on low resistance values should be made as quickly as possible. On the higher ohms range, the accuracy depends practically on the multipliers which are 1% and the meter movement accuracy, 2%. Because of the non-linear ohms scale, the resulting accuracy is not readily expressed in a percentage figure but greatest accuracy is obtained at mid scale readings.

**NOTE:** When comparing this instrument with another instrument, consider that the accuracy of the other instrument may deviate in the opposite direction. Therefore, when comparing two instruments of 5% accuracy, the total difference may be 10%. Critical comparisons should only be made against certified laboratory standards.

#### MAINTENANCE

With any electronic test equipment, there is always a possibility that repairs may be required. Information regarding the procedure to be followed can be helpful in the event that the need for service should develop. This information may eliminate the necessity for returning your VTVM to the Heath Company Factory Service Department. Bear in mind that the Factory Service Department was established for the convenience of kit builders who experience difficulty in obtaining specified performance from their kit instrument. It is not operated as an instrument maintenance service, as the kit builder is qualified to make necessary repairs through his familiarity with the instrument, circuits and design. In event specialized replacement parts are required, they can be obtained from the Heath Company. The majority of components used are standard items available from your local parts supplier.

**METER:** Because of the delicate nature of the meter movement, no attempt should be made to repair the meter. Such attempts would automatically void the standard warranty coverage of the meter itself.

**METER COVER:** In event the polystyrene meter cover is accidentally damaged, a replacement cover only is available from the Heath Company. This cover can be easily removed without detaching the meter from the panel. Use a small screwdriver or knife blade under one of the upper corners and pop off the friction fit cover. When installing a new cover, precaution should be observed regarding proper engagement of the mechanical zero adjust stud. If it is necessary to expose the meter movement to air for a period of time, protect the movement from foreign matter, dust, etc. by enclosing the instrument in a box or possibly a desk drawer.

**ELECTROSTATIC CHARGE:** The polystyrene meter cover has been treated to resist an accumulation of static electricity. However, should a static charge accumulate through repeated polishing or cleaning of the meter cover, the pointer will deflect in an erratic manner, regardless of whether the instrument is turned off or on. This condition can be quickly corrected. Obtain a small bottle of "GLIM," a commercially available dish-washing detergent. Apply a small quantity of Glim to a clean, soft cloth and wipe the surface of the meter cover. The accumulated electrostatic charge will immediately disappear. It is not necessary to remove the cover for this correction.

**IMPROPER USAGE:** Accidental improper VTVM usage, such as attempting to measure AC or DC voltage while the SELECTOR switch is in the OHMS position, will invariably result in failure of the 9.1  $\Omega$  resistor. A replacement 9.1  $\Omega$  5% resistor can be obtained from the Heath Company. A symptom of resistor failure will be slow upscale drifting of the meter pointer while the SELECTOR switch is in the OHMS position and negligible effect of the ohms adjust control.

It is possible for other examples of improper instrument usage to result in the failure of one or more precision resistors in the voltage multiplier string. The symptom of this difficulty on either AC or DC voltage measurements will be inability to obtain proper zero adjust action and, of course, incorrect voltage readings. Precision resistor failure would result in an open grid circuit condition of the 12AU7 tube.

**CHECKING METER COIL CONTINUITY:** In event failure of the meter coil is suspected, the continuity can be determined by observing the following precaution. NEVER check meter movement continuity directly with another ohmmeter. The amount of current drawn will seriously overload the meter coil and will certainly result in a definite open circuit condition. Always use a limiting resistor in series with the ohmmeter test leads. The value of the resistor will depend upon the ohmmeter battery voltage and range on which the ohmmeter is being used. Always use at least a 10,000  $\Omega$  resistor in series with the VTVM meter coil and the ohmmeter test leads.

Just remember that anytime your VTVM should need servicing, the trouble-shooting procedure is quite logical and should not present a problem. If possible, use or borrow another instrument to measure operating voltages or to make ohmmeter continuity checks. Proper operating voltages for the VTVM are shown on the schematic and deviations of  $\pm 15\%$  are entirely acceptable. Always be sure that the tubes used in the instrument are in good operating condition and they may be checked either by substitution or with a tube checker.

Because of their constant flexing during use, the test leads are not above suspicion, especially when the VTVM has been in use for several years. Erratic or improper DC voltage measurements can sometimes be caused by a fault in the black shielded test lead or in the connection of the 1 megohm isolating resistor used in the test prod.

Your VTVM has been designed to fulfill service requirements encountered in daily usage. It is capable of continuous daily service over a period of several years and it should be accorded the same degree of care in operation that would be given to any piece of fine equipment.

#### CENTER SCALE "O" POSITION

Your V-7A VTVM features a convenient center scale zero position. The adjustment range of the panel ZERO ADJUST control will permit center scale zero deflection of the meter pointer when SELECTOR switch is set to DC+ or DC-. Center scale zero may not be obtained at both positions.

The center scale zero will be useful as a null indicator in discriminator adjustments, for bias measurements or any application where polarity reversals may occur.

#### HIGH VOLTAGE TEST PROBE KIT #336 - \$4.50

A high voltage test probe in kit form is available from the Heath Company. This probe will permit VTVM DC measurements up to 30,000 volts, which covers the range of flyback power supply voltages commonly encountered in TV receivers. Probe consists of red molded housing with black molded handle. Contains 2% precision, 1090 megohm resistor and provides DC range multiplication factor of 100 for 11 megohm input VTVM's.

#### RF TEST PROBE KIT #309-C - \$3.50

A kit form RF test probe is available from the Heath Company. This probe will permit VTVM usage for RF measurements up to 30 volts substantially flat from 1000 cycles to 100 mc. Built-in isolating capacitor permits DC voltage range up to 500 volts. Uses printed circuit board for easy assembly and housing is of polished aluminum with polystyrene insulation.

## TABLE OF CONTENTS

	Page
<b>INTRODUCTION:</b>	
a. Circuit board description-----	3
b. Circuit board soldering technique-----	3
c. Component assembly procedure-----	3
<b>PRELIMINARY NOTES AND INSTRUCTIONS</b>	
a. Parts inspection-----	4
b. Numbering and designation system-----	4
c. Tolerance deviations-----	4
<b>RANGE SWITCH ASSEMBLY</b>	
a. Numbering system-----	5
b. Resistor mounting-----	6
c. Precision resistor installation-----	6 and 7
<b>PANEL</b>	
a. Mounting of controls and switches-----	7
b. Mounting banana jacks-----	9
c. Panel wiring-----	9
<b>CIRCUIT BOARD ASSEMBLY AND WIRING</b>	
a. Socket mounting-----	11
b. Resistor mounting-----	12
<b>RECTIFIER-TRANSFORMER-CONDENSERS-PILOT LIGHT</b>	
a. Rectifier mounting-----	13
b. Power transformer-----	14
c. Disc and filter condensers-----	14
d. Pilot light socket-----	14
<b>CONNECTING CABLE - BATTERY CUP</b>	
a. Insulation removal-----	14
b. Cutting to length-----	14
c. Soldering to circuit board-----	14
d. Installation of battery cup-----	14
<b>WIRING CIRCUIT BOARD TO PANEL</b>	
a. Cable preparation-----	14
b. Soldering cable wires to panel controls-----	14
<b>BRACKET</b>	
a. Installation of rubber grommet-----	16
b. Phosphor bronze battery holder spring-----	16
<b>METER</b>	
a. Preparation of terminal studs-----	16
b. Meter to panel installation-----	16
c. Circuit board installation-----	16
d. Pilot lamp and sleeve installation-----	16
<b>FINAL WIRING</b>	
a. Tube installation and precautions-----	18
b. Final check of wiring and assembly-----	18
c. Knob installation-----	18
<b>PRELIMINARY TEST</b>	
a. Operating power requirement-----	18
b. Preliminary operation observations-----	18
c. Preliminary panel control adjustment range-----	18
<b>TEST LEAD PREPARATION</b>	
a. Common test lead (black)-----	18
b. DC test lead (shielded)-----	19
c. AC-Ohms test lead (red)-----	19
<b>CABINET PREPARATION</b>	
a. Handle installation-----	19
b. Rubber feet installation-----	19
c. Panel control indexing-----	19

<b>TEST AND CALIBRATION</b>	
a. Zero adjust control check-----	19
b. DC calibrate procedure-----	19
c. Ohms check-----	19
d. AC balance and Calibrate-----	20
<b>AGING</b>	
a. Final calibration-----	20
b. Flashlight battery requirements-----	20
c. Cabinet installation-----	20
<b>IN CASE OF DIFFICULTY</b>	
Replacement parts-----	21
Service Policy-----	22
Repair Kit-----	22
Shipping Inst. -----	22
Warranty-----	22
Parts List-----	23
Circuit description-----	24
<b>USING THE VTVM</b>	
DC voltage measurements-----	25
AC voltage measurements-----	26
Resistance measurements-----	26
Decibel scale-----	27
Reading meter scale-----	27
<b>ACCURACY-----</b>	<b>27 - 28</b>
<b>MAINTENANCE-----</b>	<b>28 - 29</b>
<b>CENTER SCALE ZERO-----</b>	<b>29</b>
<b>ACCESSORIES-----</b>	<b>29</b>

**SPECIAL NOTE**

The terminals of the 9-pin miniature socket supplied in this kit are slightly longer than they need to be. There is a chance that one of the terminals might bridge across the wiring pattern and cause a short circuit. The terminals should be shortened before the socket is installed.

Clip about 1/16" from the end of each of the nine terminals on the socket and it can be installed without danger of a short circuit.

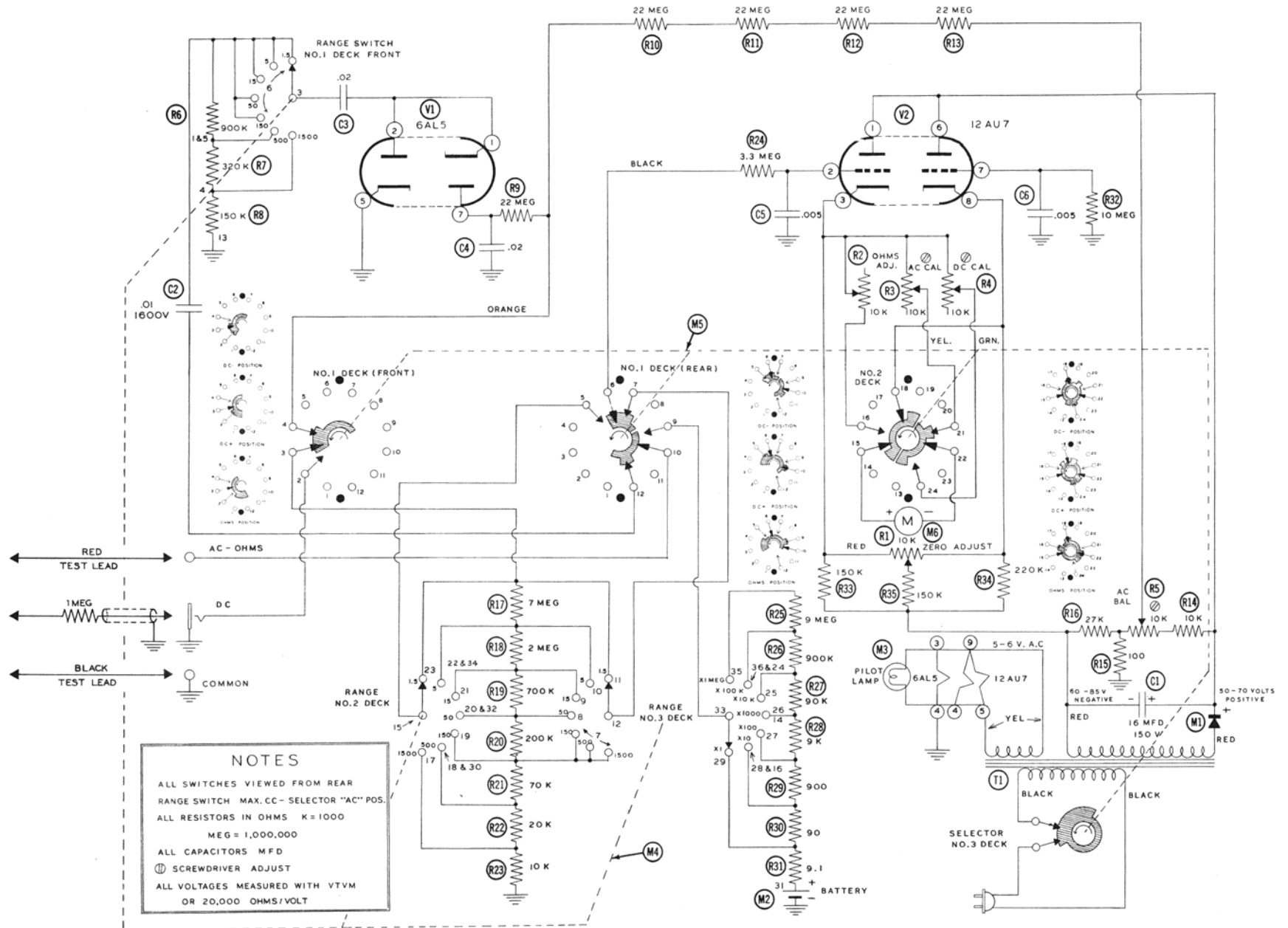

HEATHKIT PEAK-TO-PEAK VTVM  
MODEL V-7A