

"TRADER" SERVICE SHEET
960

BUSH BP10

All-dry Portable Superhet

THE Bush BP10 is a 4-valve all-dry battery portable superhet covering 185-560 m and 1,070-1,900 m in two bands. The L.T. circuit switch is turned on automatically when the roller-type shutter covering the scale is opened.

The dimensions of the receiver are about 12x10½x5½in, and the weight is approximately 10½ lb. The L.W. frame aerial is connected via the cover screws.

Release date and original price: October 1949; £13 11s 4d complete. Purchase tax extra.

COMPONENTS AND VALUES

CAPACITORS		Values	Locations
C1	L.W. fixed trim	130pF	F4
C2	V1 C.G.	100pF	F4
C3	1st I.F. transformer	60pF	B2
C4	tuning	60pF	B2
C5	V1 osc. C.G.	80pF	F4
C6	Osc. tracker	605pF	A1
C7	L.W. fixed trim	515pF	B1
C8	A.G.C. decoup.	0.05µF	F4
C9	V2 C.G. decoup.	0.05µF	F4
C10	V2 S.G. decoup.	0.05µF	F3
C11	2nd I.F. transformer	60pF	C2
C12	tuning	60pF	C2
C13	I.F. by-passes	100pF	D4
C14	I.F. by-passes	100pF	D3
C15	A.F. coupling	500pF	D3
C16	V3 S.G. decoup.	0.05µF	D3
C17	I.F. by-pass	100pF	D4
C18	A.F. coupling	0.005µF	D4
C19	Tone corrector	0.005µF	—
C20*	V4 G.B. by-pass	50µF	C2
C21	H.T. decoupling	0.5µF	B2
C22†	M.W. aerial trim	40pF	A2
C23†	L.W. aerial trim	40pF	A2
C24†	Aerial tuning	523pF	A2
C25†	Osc. tuning	523pF	A2
C26†	L.W. osc. trimmer	40pF	A2
C27†	M.W. osc. trimmer	40pF	A2

RESISTORS		Values	Locations
R1	V1 C.G.	2.2MΩ	F4
R2	V1 osc. C.G.	100kΩ	F4
R3	V1 C.G. decoup.	4.7MΩ	E3
R4	H.T. feed	22kΩ	F3
R5	I.F. stopper	47kΩ	E4
R6	A.G.C. feed	2.2MΩ	F4
R7		2.2MΩ	F4
R8	Volume control	500kΩ	D3
R9	V3 C.G.	4.7MΩ	D3
R10	V3 grid stopper	100kΩ	D4
R11	V3 pent. load	470kΩ	D4
R12	V3 S.G. decoup.	2.2MΩ	E3
R13	V4 C.G.	1MΩ	D4
R14	V4 G.B.	510Ω	C2

OTHER COMPONENTS		Approx. Values (ohms)	Locations
L1	M.W. frame aerial	2.0	—
L2	L.W. frame aerial	10.0	—
L3	Oscillator coils	2.0	B2
L4		2.5	B2
L5	1st I.F. trans.	12.5	B2
L6		12.5	B2
L7	2nd I.F. trans.	12.5	C2
L8		12.5	C2
L9	Speech coil	2.0	—
T1	Output trans.	750.0	—
S1-S3	Waveband switches	0.6	A1
S4		L.T. switch	—

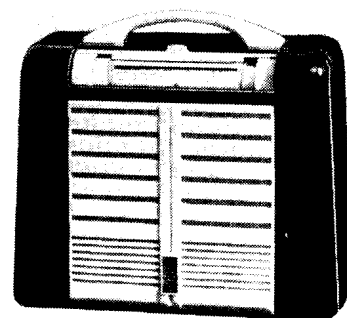

The appearance of the Bush BP10 portable. The scale cover (shown open) operates the battery switch.

Second valve (V2, Mullard DF91) is an R.F. pentode operating as intermediate frequency amplifier with tuned transformer couplings C3, L5, L6, C4 and C11, L7, L8, C12.

Intermediate frequency 465 kc/s.

Diode signal detector is part of diode pentode valve (V3, Mullard DAF91). Audio frequency component in rectified output is developed across manual volume control R8 and passed via A.F. coupling capacitor C15 and stopper R10 to control grid of pentode section, which operates as A.F. amplifier. I.F. filtering by C13, R5, C14 in the diode circuit, and C17 in the pentode anode circuit.

Potential divider R6, R7 feeds back a proportion of the D.C. potential developed across R8 as bias to F.C. valve, giving automatic gain control. The I.F. valve bias is fixed.

Resistance-capacitance coupling by R11, C18 and R13 between V3 pentode and pentode output valve (V4, Mullard DL94). Fixed tone correction in anode circuit by C19. Grid bias potential for V4 is obtained from the drop across R14 in the H.T. negative lead to chassis. Electrolytic capacitor C20 by-passes R14.

CIRCUIT DESCRIPTION

Tuned frame aerial input L1, C24 (M.W.) or L1, L2, C24 (L.W.) precedes a heptode valve (V1, Mullard DK91) operating as frequency changer with electron coupling.

A single triode oscillator grid coil L3 is used to cover both wavebands, tuned by C25 with series tracking by C6. On M.W., it is shunted by the trimmer C27, and L.W. coverage is obtained by shunting it further with C7, C26 via S3. Inductive reaction coupling by L4.

* Electrolytic. † Variable. ‡ Pre-set.
|| "Swing" value, min. to max.

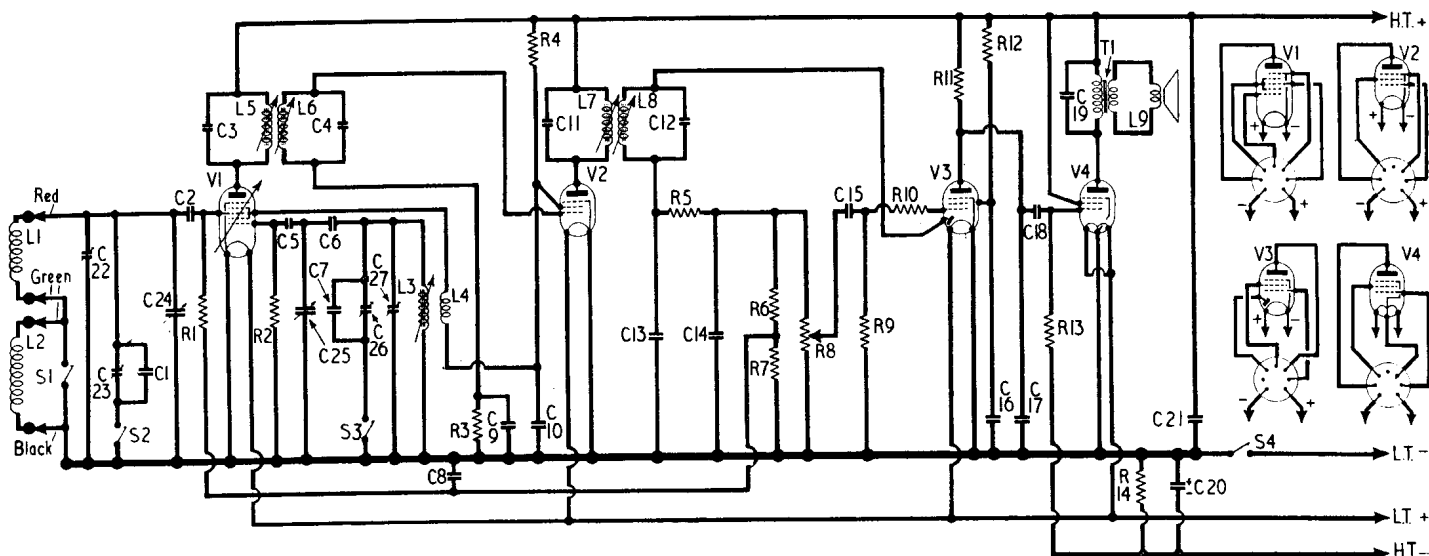

Circuit diagram of the Bush BP10 all-dry battery superhet. R7 was omitted in early versions, and C5 was 100 pF. The colours of the frame aerial leads are indicated here and in the under-chassis view overleaf. There are two green leads, joined together in the chassis but going to different frame windings.

VALVE ANALYSIS

Valve voltages and currents given in the table below are those quoted by the manufacturers. Voltages were measured on the 1,000 V range of a model 7 Avometer, chassis being the negative connection. The volume control was at maximum, but there was no signal input.

Valves	Anode		Screen	
	V	mA	V	mA
V1 DK91 ...	85	0.35	40	1.25
V2 DF91 ...	85	1.8	40	0.63
V3 DAF91 ...	10	0.12	6	0.03
V4 DL94 ...	80	5.3	35	1.0

DISMANTLING THE SET

Removing Chassis.—Slide the H.T. and L.T. batteries out and unplug their connectors; untape the leads from the battery retaining bracket on bottom of carrying case;

unsolder the frame aerial leads from tags at the bottom rear edge of the case, and the speaker leads from the output transformer. Lay the carrying case face downwards and release the four captive bolts which secure the end flanges of the chassis to the top front of the cabinet;

withdraw the chassis sufficiently to allow the two leads to be unsoldered from the tag strip in the top left corner of the M.W. frame assembly, when the chassis may be withdrawn.

When replacing, connect the long green lead to the left hand tag at the bottom rear edge of the case, and the black lead to the right hand tag;

connect the red lead to the tag on the output transformer nearer the front of the case, and the yellow lead to the rear tag;

connect the short green and black leads to the tag strip in the top left hand corner of the M.W. frame aerial assembly, taking the green lead to the tag near the front of the case and the red lead to the rear tag.

Removing M.W. Frame Aerial.—Remove four 6BA counter-sunk screws which hold the two back-cover securing brackets to the bottom rear edge of case;

slacken the two 4BA screws on each side of the frame aerial assembly, when it can be lifted slightly upwards and withdrawn by tilting the lower edge outwards.

When replacing, the tag strip should be at the top left hand (viewed from rear) corner of the case.

Removing L.W. Frame Aerial.—Remove the four 4BA cheese-head screws holding the frame aerial to the back-cover and unsolder the tinned copper wires from the two tags on the back of the frame assembly, when it can be withdrawn.

When replacing, the two holes through which the lower fixing screws of the back-cover project go at the bottom.

Removing Speaker.—Remove the 4BA cheese-head screw with washer securing top of speaker to carrying case;

Plan view of the chassis. The switches at each end form part of the scale assembly. S1-S3 are the waveband switches. Trimmers C22 and C23 are accessible through a slot in the back of the carrying case.

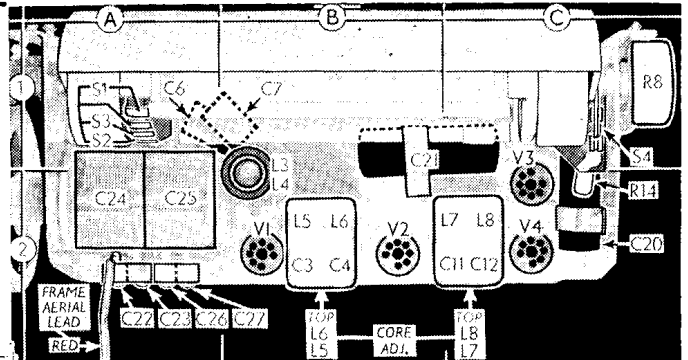

remove four self-tapping screws from front of cabinet when the cream coloured speaker grill may be pulled out; remove the three 4BA cheese head nuts and bolts (with washers and spacers), now made accessible from the front of the carrying case, and withdraw speaker. **When replacing,** the output transformer should be at the bottom right-hand (viewed from rear) corner of case. position the three bolts (with spacers inside)

at each end. S1 closes on M.W., and S2, S3 close on L.W.

S4 is the L.T. circuit switch, operated by the roller-type shutter which covers the tuning scale. When the shutter is opened the switch closes automatically.

Frame Aerials.—The M.W. frame aerial L1 is mounted on an aluminium support mounted in the carrying case. The L.W. frame L2 is wound in a smaller rectangle on the back cover. Connection between L2 and the receiver is effected via the fixing screws on the back cover and their brackets on the base of the case.

Batteries and Leads.—The L.T. unit is an Every Ready "Alldry 4" battery, rated at 1.5 V. It has a two-pin connector of which the thicker pin is positive. The H.T. battery consists of two Ever Ready "Batrymax" type B104 units, rated at 45 V each, and having three-pin connecting plugs of which the flat pin is used only as a locating device to render the plug non-reversible. The nearer of the active pins to this one is positive.

Drive Cord Replacement.—About three feet of nylon braided glass yarn is required for the drive cord, and it is run as shown in the sketch (col. 2), where the drive is viewed from the right-hand front corner of the chassis, with the gang at maximum capacitance.

The work is facilitated if the scale panel is removed. It is held by a retaining bar at its lower edge (two 6BA screws with washers).

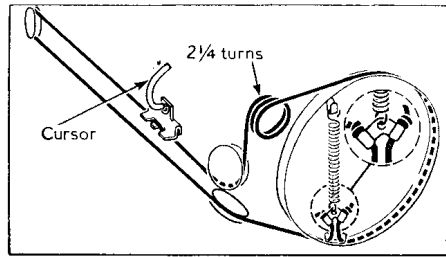

The tuning drive cord system, viewed from the front right-hand corner of the chassis.

on the front of the case and secure them by replacing the speaker grill temporarily; insert the top 4BA screw (shortest screw, with washer and spacer) and replace speaker over the three bolts, tightening the top screw and threading on the three lower nuts; remove speaker grill and tighten the nuts and bolts.

CIRCUIT ALIGNMENT

When aligning the I.F. stages, the chassis should be removed from the carrying case to facilitate the connection of a damping unit. This unit, consisting of a 30 kΩ resistor and a 0.05 μF capacitor in series, should be connected across the I.F. transformer secondary while adjusting the primary, and vice versa.

I.F. Stages.—Switch set to M.W. and tune to about 300 m on scale; turn volume control to maximum and connect signal generator (via a 0.1 μF capacitor in the "live" lead) to control grid (pin 6) of V1. Feed in a 465 kc/s (645.16 m) signal and, using the damping unit referred to above, adjust the cores of L8, L7, L6 and L5 (location references C2, B2) for maximum output, reducing the input as the circuits come into line to avoid A.G.C. action.

R.F. and Oscillator Stages.—In order to adjust the core of L3, the chassis should be removed from the carrying case and placed on the bench. Final adjustments to the aerial trimmers must be made with the chassis in the case, and the back and batteries in position, the trimmers being accessible through a slot in the back cover. With the gang at maximum capacitance, the cursor should coincide with the brown dot at the high wavelength end of the scale. It should be noted that the maximum capacitance setting of the gang is determined by a mechanical stop on the drive drum and not by maximum rotation of the gang. Connect the signal generator leads to a loop, approximately 8in by 6in, placed 10 to 20in from the frame aerial and parallel to it.

M.W.—Switch set to M.W., tune to 500 m on scale, feed in a 500 m (600 kc/s) signal and adjust the core of L3 (F4) for maximum output. Tune to 200 m on scale, feed in a 200 m (1,500 kc/s) signal and adjust C27 (A2) and C22 (A2) for maximum output. Repeat these adjustments.

L.W.—Switch set to L.W., tune to 1,400 m on scale, feed in a 1,400 m (214 kc/s) signal and adjust C26 (A2) and C23 (A2) for maximum output. Repeat these adjustments.

GENERAL NOTES

Switches.—S1-S3 are the waveband switches, in a unit which forms an integral part of the scale assembly. The tags are identified in our plan view of the chassis, but the switch unit is not visible until the scale assembly is dismantled, which involves removing the controls

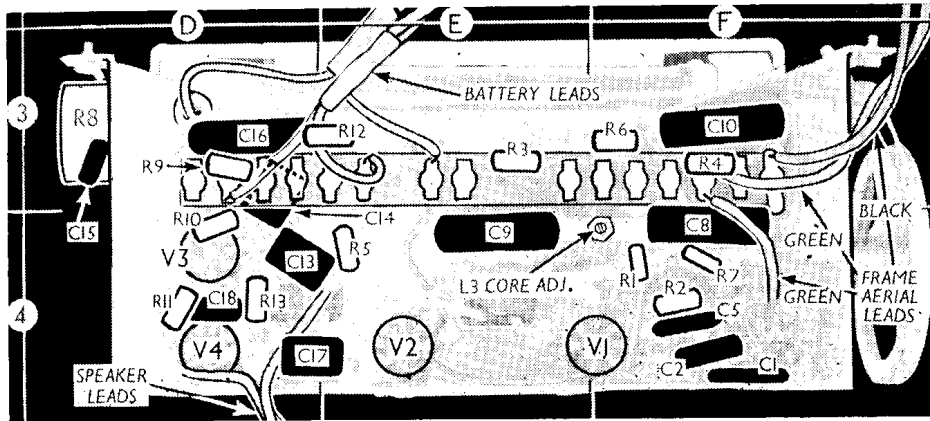

Under-chassis view, showing the battery lead and frame aerial lead connections. The two green frame aerial leads go to opposite ends of the same tag.