

"TRADER" SERVICE SHEET
1533

BRC 2019

Automatic Record Player

DESIGNED to operate from A.C. mains supplies the BRC 2019 is an automatic record player incorporating the B.S.R. record changer type UA14. The amplifier has a push-pull output stage providing an output power of approximately 5W driving an 8in by 5in elliptical loudspeaker. Mains input voltage is 200-250V 50c/s and the mains power consumption is approximately 38W at 240V. Release date and original price: July 1961, £19 0s 3d. Purchase tax extra.
(Continued overleaf, col. 1)

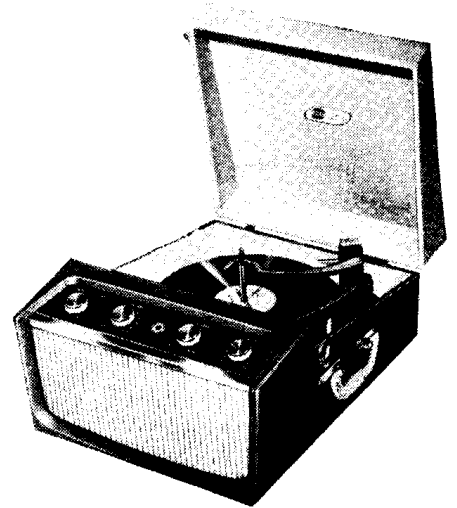

VALVE ANALYSIS

Valve voltages in the adjoining table are taken from information supplied by the manufacturer. They were measured on an Avometer model 8 with a mains input of 235V 50c/s and the voltage adjustment set to the 230-250V position.

Remove the control panel cover for access to the mains adjustment plug.

VALVE TABLE

Valve	Anode (V)	Screen (V)	Cathode (V)
V1 UCL83	a	100	0.3
	b	218	12.9
V2 UCL83	a	167	2.6
	b	218	12.9

H.T. voltage across C15, 222 V.

Capacitors

C1	0.02µF	B1
C2	0.02µF	B1
C3	0.01µF	A2
C4	400pF	A2
C5	0.002µF	A2
C6	0.04µF	A3
C7	8µF	B2
C8	0.01µF	B3
C9	75pF	B2
C10	0.01µF	B3
C11	0.01µF	B3

C12	50µF	C2
C13	0.002µF	B3
C14	40µF	B2
C15	40µF	B2
C16	0.1µF	A3

Resistors

R1	1MΩ	A2
R2	470kΩ	A1
R3	470kΩ	A2
R4	500kΩ	A2
R5	250kΩ	A3

R6	10MΩ	B3
R7	390Ω	B3
R8	100kΩ	B3
R9	680kΩ	B3
R10	1kΩ	B3
R11	22kΩ	B2
R12	22kΩ	B2
R13	470kΩ	B2
R14	470kΩ	B3
R15	220Ω	C3
R16	5.6kΩ	B2
R17	10kΩ	B2

R18	10kΩ	B3
R19	820Ω	B2
R20	100Ω	C1
R21	100Ω	C1

Miscellaneous

L1	3Ω	—
T1	{ a 500Ω } { b — }	—
W1	—	B2
X1	CZ2	C3
S1, S2	—	A1

Circuit diagram of the BRC2019 record player. Part of the motor winding is included in the heater circuit as a voltage dropping device

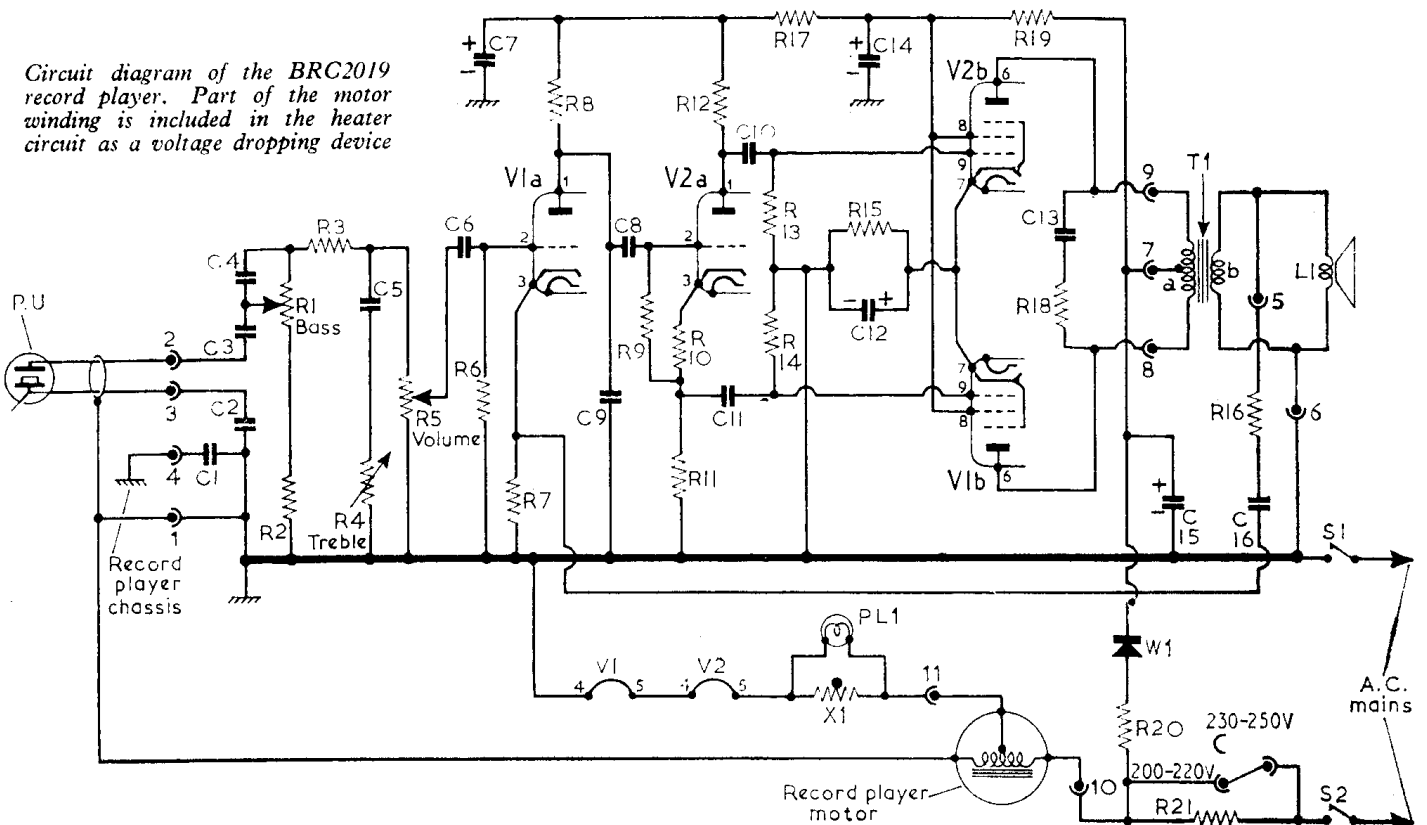

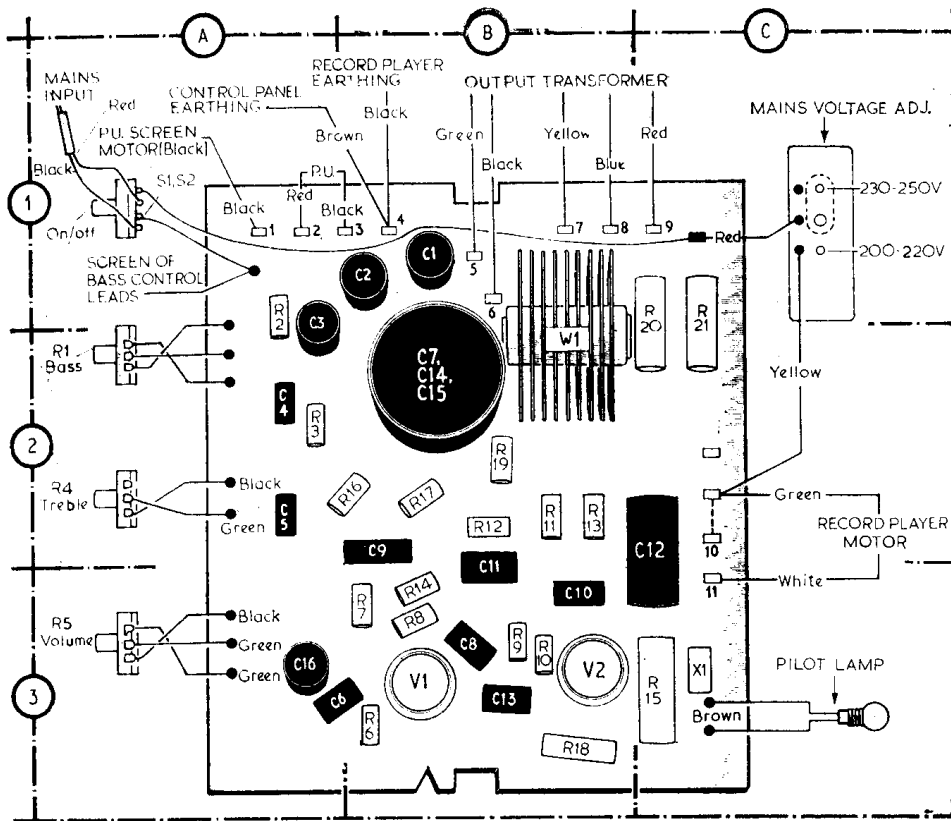

Illustration of the amplifier panel and its external connections. Access to the mains voltage adjustment can only be obtained by removing the peg-board cover behind the control panel. To maintain the correct valve heater voltage, a clip on the B.S.R. record player on/off switch prevents independent switching of the player

(Continued from overleaf)

RECORD CHANGER

The automatic record changer is the B.S.R. type UA14. It is modified by the addition of a spire-fix clip on the automatic switch. This clip ensures that the motor is switched permanently in the "on" position. If the record changer is replaced, the clip should be transferred to the replacement.

CIRCUIT NOTES

Two triode-pentodes are employed, the pentode sections comprising the push-pull output stage and the triodes operating as pre-amplifier and phase-splitter stages. Input is from a crystal cartridge with a bass and treble tone control circuit, formed by C4, R1 and R2 (bass) and C5 and R4 (treble), followed by the volume control R5.

Following amplification by V1a the signal is applied to the grid of V2a and from V2a, equal and opposite signal voltages are taken from its anode and cathode and fed via C10 and C11 to the control grids of the output pentodes V1b and V2b. R11 and R12 are respectively the cathode and anode load resistors, R10 is the cathode bias resistor.

V1b and V2b anodes are connected to centre-tapped output transformer T1 in anti-phase. A measure of output is coupled via C16 and R16 back to V1a cathode as negative feedback. H.T. current is supplied by a metal rectifier W1.

Economy is made in mains dropping resistance by connecting the valve heaters and pilot lamp to a tapping on the gram motor coil.

DISMANTLING

Record Changer.—To remove the record changer, remove the chassis ventilation panel from the inside of the cabinet (2 screws).

Detach the mains voltage selector panel from the record changer board (two wood screws).

Remove five woodscrews and washers securing the record changer board to the cabinet.

Lift record changer assembly, tilting the right-hand edge downwards to clear the protruding handle fixing nuts.

Rest the assembly in the vertical position with the rear edge of the motor diagonally on the bottom of the cabinet, then remove the motor supply, earthing connection and pick-up connections from tags on the printed board.

Remove record changer completely from the cabinet.

Printed Panel.—To remove the printed panel, first remove the record changer as just described.

Take off the indicator panel control knobs by slackening the grub screws.

Disconnect all the remaining printed panel "push-on" connections.

Remove two 4BA nuts and the clamping strips securing the right-hand edge of the printed board.

Undo the clamping screw and release the mains lead from the side of the cabinet.

Remove two screws securing the rear of the control panel to the cabinet top.

Remove the printed panel complete with mains lead and voltage selector assembly.

GENERAL NOTES

Printed Panel Servicing.—When replacing resistors or capacitors, cut away the faulty component leaving as much lead wire as possible, then solder the replacement component to the original lead wires. Where this type of connection is not possible and connection must be made to the copper side of the panel, use a small soldering iron, non-corrosive flux and 60-40 solder.

Do not apply the iron for longer than it is necessary. To remove components secured by clip lugs, use a heavier type of iron and apply pressure as well as heat to the lugs to ensure that as the solder melts the lug is pressed clear of the connecting point.

Cartridge and Stylus Replacement.—The turnover pick-up crystal cartridge is type TC8M and the stylus types are L.P., TC8R (coloured red), 78, TC8G (coloured green). The correct types should be used as replacements. When replacing a stylus do not remove the securing screw as slackening by one turn is sufficient for the stylus to be withdrawn.

Pilot Lamp.—This is an 8V 0.15A 12mm M.E.S. fitting.