

AMBASSADOR**Model 650H**

General Description : Six-valve (including rectifier), two-waveband high-fidelity superheterodyne receiver. Released March 1950.

Power Supplies : A.C. and A.C./D.C. models, 200–250 volts.

Intermediate Frequency : 420 kc/s.

Valves : (V1) UCH42; (V2) UAF42 (I.F. and A.V.C. diode); (V3) UCH42 (Det. and phase inverter); (V4 and V5) UL41s (push-pull output); (V6) UY21.

General Notes : Although mainly an A.C. receiver, A.C./D.C. technique is employed throughout, all the valve heaters being series connected and supplied by a 180-volt tap on the H.T. secondary. The dial lamps on A.C. models are 6.3 volts and supplied by a separate winding on the transformer.

Features : The A.F. response should be ± 2 db. from 30 to 16,000 c/s. and give 5 watts with no visible distortion on an oscillograph.

In the first run A.V.C. delay and standing bias for the F.C. and I.F. valves are obtained from a 1.5-volt cell connected so as to apply positive bias to the I.F. suppressor and effectively short down through the valve, the A.V.C. line. In later models this suppressor bias for delay is derived from a bleeder chain, while the F.C. and I.F. standing bias is obtained from a resistor in the H.T. negative lead.

The A.C./D.C. chassis employs a Brimistor in the heater chain, and the dial lamps are 3.5-volt lamps wired in parallel with each other, in series with the negative mains lead and shunted by a 100-ohm resistor, which is in practice an isolated section of the ballast resistor.

Faults : Instability, denoted by a whistle on the sidebands of all stations, may occur on earlier models. It is due to regeneration in the I.F. amplifier, and can be cured by wiring a 0.22M resistor from I.F. anode to H.T.

A.F. Instability : A high-pitched whistle can occur if the output valve anodes by-pass capacitors are not positioned well down towards the chassis.

Modulation Hum : This should not be excessive, but in special cases where it does occur it can be cured by reducing C1 (0.001) to 500 pF. and connecting a 5000-ohm resistor across R3 (68k).

Alignment Procedure :

<i>Connect Generator</i>	<i>Inject</i>	<i>Tune Receiver to</i>	<i>Adjust in Order Stated</i>
Aerial socket through dummy aerial	1200 kc/s.	250 m.	T5, T3
	600 kc/s.	500 m.	L5, L3
	250 kc/s.	1200 m.	T4, T2
	166.6 kc/s.	1800 m.	L4, L2
	420 kc/s.	M.W.	L1 for minimum (wavetrap)

The I.F. alignment procedure must be carried out according to the procedure outlined on page 159, and care must be taken that the desired response curve is achieved. To one side, or other, of the I.F. frequency, the receiver output should not fall more than 3 db. while the generator is detuned by 8 kc/s. At the other side it should fall sharply. The main peak must always be at 420 kc/s.

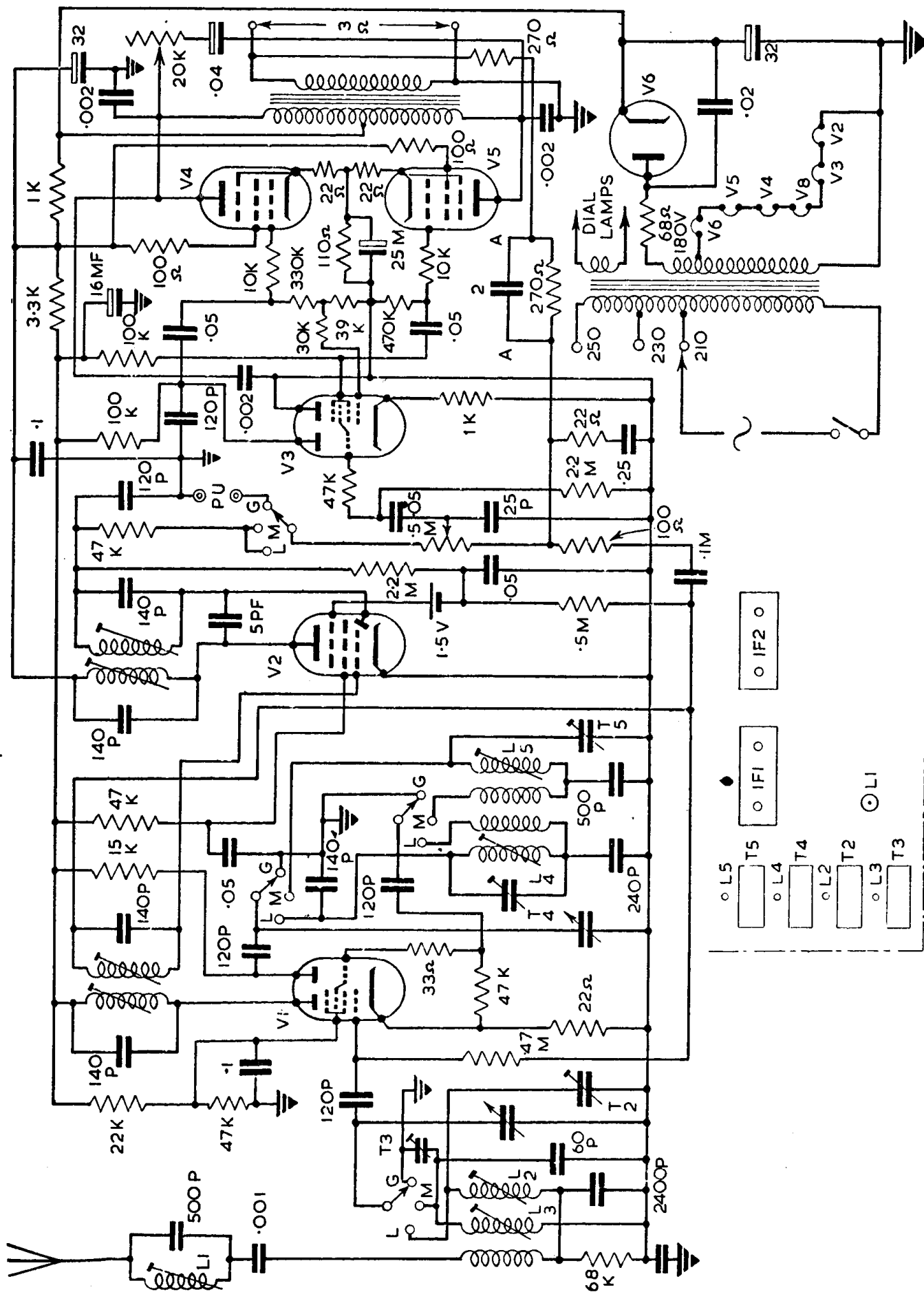

CIRCUIT DIAGRAM—AMBASSADOR MODEL 650H

AMBASSADOR RECEIVERS

GENERAL NOTES

Manufacturers : R. N. Fitton, Ltd., Princess Works, Brighouse, Yorkshire.

Removal of Chassis :

(a) *Table Models.* Lie receiver on back and unscrew chassis-retaining bolts on underside of cabinet. Stand receiver upright and remove back panel and loudspeaker plugs, etc. Remove knobs (clip-on knobs which are stiff can be removed by pressing string underneath them) and withdraw chassis from cabinet.

(b) This system also applies to *Table Radiograms* and *Consoles*. Large radiograms employ various methods, but no difficulty should be experienced, as fitting has always been kept as simple as possible.

I.F. Alignment : Except on Models 4756, 548, 849 and 650H, all alignment is carried out in the normal manner, *i.e.*, adjustment of each I.F. trimmer, in turn, for maximum output. On the chassis types 4756, 548 and 849 a damping stick is necessary. This takes the form of a 22k resistor in series with a 0.01- μ F. capacitor. In use, the 0.01- μ F. capacitor is clipped on to the chassis and the free end of the 22k resistor is connected to the live end of one winding; the other winding of the same transformer is then adjusted for maximum output. The 22k resistor is then transferred to this winding and the first winding adjusted. This alignment method gives a broad and flat I.F. response, with a consequent improvement in reproduction.

In the 650 receiver it is necessary to supply external bias from a battery during alignment. The positive terminal of a 9-volt battery is connected to chassis, and the 6-volt terminal to the A.V.C. end of the I.F. valve grid coil. The signal generator earthy lead is connected to -4.5 volts. Alignment of the second I.F. is then carried out with damping, as above. The first I.F. is then adjusted for maximum output, without damping. The primary and secondary adjustments must be carried out two or three times. The resultant I.F. response has a main peak at 420 kc/s., and should not fall below -4 db. until the generator output is varied beyond 8 kc/s. to one side of 420 kc/s. On the other side of 420 kc/s. it should be sharply attenuated.

A non-metallic trimming tool must be used for aligning the 849 and later models.

On A.C./D.C. table models produced before 1948, a 0.01- μ F. capacitor is used to isolate the pick-up from chassis. If it is desired to use a record player, a crystal pick-up can be employed without alteration. If it is desired to use a magnetic pick-up the isolation capacitor must be shorted out. It would be wiser in this case to use a pick-up which has its windings isolated from the player board, so that the latter can be earthed.