

INSTRUCTION MANUAL
1060 SERIES
SWEEP/SIGNAL
GENERATOR

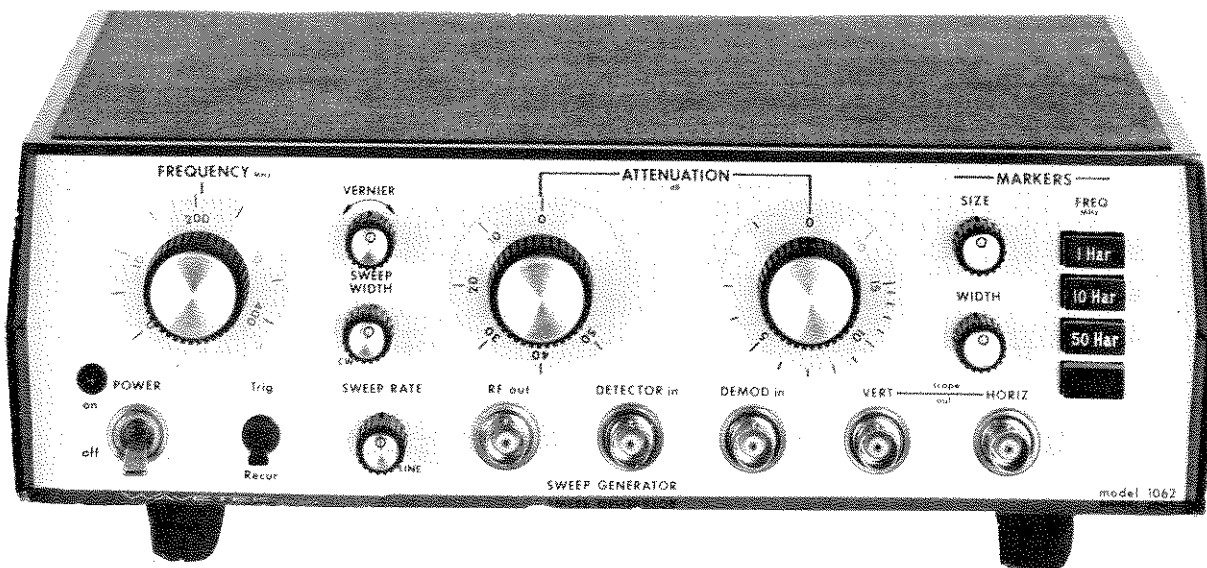

WAVETEK INDIANA INC.

66 N. 1ST. AVENUE, P.O. BOX 190
BEECH GROVE, INDIANA 46107
317-783-3221

WARRANTY

All Wavetek instruments are warranted against defects in material and workmanship for a period of one year after date of manufacture. Wavetek agrees to repair or replace any assembly or component (except batteries) found to be defective, under normal use during this period. Transfermatic Switch assemblies, manufactured by Wavetek, are unconditionally warranted for the life of the instrument. Wavetek's obligation under this warranty is limited solely to repairing any such instrument which in Wavetek's sole opinion proves to be defective within the scope of the warranty when returned to the factory or to an authorized service center. Transportation to the factory or service center is to be prepaid by purchaser. Shipment should not be made without prior authorization by Wavetek.

This warranty does not apply to any products repaired or altered by persons not authorized by Wavetek, or not in accordance with instructions furnished by Wavetek. If the instrument is defective as a result of misuse, improper repair, or abnormal conditions or operations, repairs will be billed at cost.

Wavetek assumes no responsibility for its product being used in a hazardous or dangerous manner either alone or in conjunction with other equipment. High voltage used in some instruments may be dangerous if misused. Special disclaimers apply to these instruments. Wavetek assumes no liability for secondary charges or consequential damages and, in any event, Wavetek's liability for breach of warranty under any contract or otherwise, shall not exceed the purchase price of the specific instrument shipped and against which a claim is made.

Any recommendations made by Wavetek for use of its products are based upon tests believed to be reliable, but Wavetek makes no warranty of the results to be obtained. This warranty is in lieu of all other warranties, expressed or implied, and no representative or person is authorized to represent or assume for Wavetek any liability in connection with the sale of our products other than set forth herein.

SCOPE OF THIS MANUAL

This manual provides descriptive material and instructions for the installation, operation, maintenance, and repair of the Wavetek 1060 Series Sweep/Signal Generator.

This document contains information proprietary to Wavetek. The information in this document is not to be used or duplicated in any manner without the prior approval in writing of Wavetek.

1060 SERIES

CONTENTS

SECTION 1 - GENERAL INFORMATION

- 1.1 INTRODUCTION
- 1.2 SPECIFICATIONS
- 1.3 OPTIONS
- 1.4 ACCESSORIES

SECTION 2 - OPERATING INSTRUCTIONS

- 2.1 INTRODUCTION
- 2.2 INSTALLATION
- 2.3 DESCRIPTION OF FRONT PANEL
- 2.4 DESCRIPTION OF REAR PANEL
- 2.5 TYPICAL OPERATING SETUP
- 2.6 SPECIAL OPERATING NOTES
- 2.7 EXTERNAL PROGRAMMING

SECTION 3 - THEORY OF OPERATION

- 3.1 INTRODUCTION
- 3.2 SIMPLIFIED BLOCK DIAGRAM
- 3.3 POWER SUPPLY
- 3.4 SWEEP RATE
- 3.5 SWEEP DRIVE
- 3.6 OSCILLATOR LEVELER
- 3.7 SWEEP OSCILLATOR
- 3.8 LEVEL MODULATOR
- 3.9 BIRDY AMPLIFIER
- 3.10 INTERNAL MARKERS
- 3.11 EXTERNAL MARKER
- 3.12 PULSE MARKERS
- 3.13 PILOT CARRIER NOTCHES AND TILT CONTROL
- 3.14 TILT CONTROL

SECTION 4 - MAINTENANCE

- 4.1 INTRODUCTION
- 4.2 SERVICE INFORMATION
- 4.3 PERFORMANCE CHECKS & CALIBRATION
- 4.4 TROUBLESHOOTING
- 4.5 MARKER INSTALLATION

1060 SERIES

CONTENTS
(continued)

SECTION 5 - REPLACEABLE PARTS

- 5.1 INTRODUCTION
- 5.2 MANUFACTURERS CODE
- *** PARTS LISTS

SECTION 6 - SCHEMATICS

- 6.1 INTRODUCTION
- 6.2 SCHEMATIC NOTES
- 6.3 ABBREVIATION CODE
- 6.4 SCHEMATIC INDEX
- *** SCHEMATICS

CHANGE INFORMATION, IF ANY, IS
LOCATED AT THE REAR OF THIS MANUAL.

SECTION 1

GENERAL INFORMATION

1.1 INTRODUCTION

The Wavetek 1060 Series is a family of rugged, low cost, solid state sweep generators covering the frequency range of 1 to 400 MHz. The Models 1061 and 1062 are general purpose sweep generators designed for a variety of applications, while the Models 1066 and 1067 are designed primarily for CATV use. Each unit features 20 dB PIN diode leveling and remote programming of center frequency, sweep width, and output level. Up to five crystal controlled marker modules may be plugged into the unit. These modules are controlled by convenient front panel ON/OFF switches. Marker amplitude and width controls enable optimum adjustment

of the marker display. Additionally, an external marker option can provide a marker by combining an external CW source with a sample of the sweep oscillator signal. Other optional features include an adjustable Pilot Carrier Notch control, and a sweep display Tilt control for use in CATV applications.

The 1060 Series features modular plug-in construction, which allows optional features to be factory installed at the time of purchase, or customer installed at a later date. This concept offers protection against obsolescence since updated and additional features can be easily and economically added as new requirements dictate.

1.2 SPECIFICATIONS

1.2.1 RF SPECIFICATIONS

Frequency Range	1 to 400 MHz
Operating Modes	Sweep and CW
Frequency Dial	
calibration	50 MHz intervals
accuracy	20 MHz
Sweep Width	200 kHz to 400 MHz
Display Linearity	2%
Spurious Signals	(Fundamental - 10 to 400 MHz)
harmonic	30 dB below the output
non-harmonic	30 dB below the output
Residual FM	less than 20 kHz
Drift	100 kHz/5 minutes - 2 MHz/8 hours (after ½ hour warmup at constant temperature, and allowing a 5 minute stabilizing period after a frequency change.)
Blanking	Retrace blanking of the RF output pro- vided for sweep operation. Removed for CW operation.

RF Output Amplitude	
Models 1061 and 1062	Continuously adjustable from +10 to -60 dBm.
level calibration	50 dB in 10 dB steps; 20 dB vernier with 0 to -15 dB calibrated in 1 dB increments
accuracy	Vernier: ± 1 dB
	Step Attenuator: ± 0.2 dB/10 dB step
RF Output Amplitude	
Models 1066 and 1067	Continuously adjustable from +57 to -13 dBmV.
level calibration	50 dB in 10 dB steps; 20 dB vernier with +7 to -7 dBmV calibrated in 1 dB increments.
accuracy	Vernier: ± 1 dB
	Step Attenuator: ± 0.2 dB/10 dB step
RF Output Impedance	
Models 1061 and 1062	50 Ω standard (75 Ω optional)
Models 1066 and 1067	75 Ω only
RF Output Flatness	± 0.25 dB (measured with Wavetek detector)
DC Blocking	Models 1066 and 1067 include a DC block (100 V max.) in the RF output line.
Internal RF Detector	
Models 1061 and 1062	50 Ω standard (75 Ω optional)
Models 1066 and 1067	75 Ω only
	(Each contains a DC block)

1.2.2 SWEEP

Models 1062 and 1067	Modes: Repetitive sweep, single sweep, externally triggered sweep, line locked sweep
	Rates: continuously variable from less than 0.5 Hz to more than 60 Hz.
Models 1061 and 1066	Line locked, 50 or 60 Hz.

1.2.3 SCOPE HORIZONTAL

10 Vpp triangular waveform (symmetrical about ground).

1.2.4 RF MARKERS

Pulse and birdy type markers are provided by plug-in "A" options. Six sockets are provided for these options. Birdy marker modules use one socket; pulse markers use two.

Marker Modules

Birdy Markers

A1 Option	<u>Single frequency markers</u> at any frequency within the instrument frequency range (Module M6S-).
---------------------	--

A2 Option Harmonic or comb type markers at 1, 10, 50 MHz and a double marker which contains markers at .1 and 1 MHz. Other frequencies available on special order (Module M6H-).

A3 Option External marker provides a marker by combining a CW source supplied by an external source and a sample of the sweep oscillator signal. A connector mounted on the instrument rear panel requires a signal of .1 V into 50 ohms from an external source to produce a marker. (Module M6C).

Pulse markers

A4 Option Single frequency markers between 35 and 52 MHz. Up to 5 pulses per module selected by plug-in crystals (Module M13J).

Marker switching

Four front-panel switches control the 6 Marker sockets in the following manner.

Marker socket a This socket is always "on" and is normally used for option A3.

Marker socket b, c, d These three sockets are individually turned on by the top three front-panel buttons.

Marker sockets e and f These two sockets are turned on together by the bottom front-panel button and are normally used for option A4.

Marker size

Adjustable approximately from 2 mVpp to 2 Vpp.

Marker Width

Pulse ≈80 μs

Birdy adjustable, ≈100 to 400 kHz

Marker Accuracy

Pulse 0.02% (at leading edge)

Birdy 0.005% (at center)

1.2.5 Programming

The rear-panel REMOTE jack provides for remote control of center frequency, sweep width, and 20 dB of the output level. The connections can also be used to provide external AM or FM as specified in Table 1-1.

Also provided is access to ± 18 V (30 mA), blanking and SCOPE HORIZONTAL signals, plus an input for triggering the sweep rate generator (requires +10 V pulse).

Table 1-1. External Modulation

AM -	
Percent	90% max
Modulating Frequency	DC to 25 kHz
Sensitivity	9% AM per volt
Input Impedance	10 k Ω
Note: The output level must be reduced by at least 6 dB by the VERNIER control to allow 90% modulation.	
FM -	
Input Impedance	10 k Ω
Sensitivity	50 MHz per volt
Deviation	entire range of instrument
Modulating Frequency	DC - 4 kHz at above deviation, up to 100 kHz with reduced deviation and linearity

1.2.6 POWER REQUIREMENTS 115 or 230 VAC $\pm 10\%$, 50 or 60 Hz, 25 VA max.

1.2.7 MECHANICAL

Coaxial Connectors

- Models 1061 and 1062 Type BNC
- Models 1066 and 1067 Type F

- Width 11 $\frac{1}{4}$ " (28.6 cm)
- Height 4" (10.2 cm)
- Depth 10 $\frac{1}{2}$ " (26.7 cm)
- Weight 8 $\frac{1}{4}$ lb. (3.7 kg.)

1.2.8 ENVIRONMENTAL Specifications apply at 25 $^{\circ}$ C $\pm 5^{\circ}$ C. The instrument will operate over the range of 0 $^{\circ}$ C to 50 $^{\circ}$ C.

1.3 OPTIONS

1.3.1 "A" Options For specifications of frequency markers see section 1.2.4.

1.3.2 "B" Options The instrument has provisions for including one of the following "B" options. The options are mounted inside the rear panel through which any required controls are accessible.

- B2 - Pilot Carrier Notches
and Tilt control This option applies to instruments used in CATV applications. The output is blanked at two adjustable frequencies. A single ON/OFF switch is located on the rear panel. Two external controls determine the notch frequency. An internal adjustment determines the notch width between 3 and 10 MHz (this option includes Option B3, Tilt control).
- B3 - Tilt Control This option can be used to simulate or compensate for cable losses. Depending on the output VERNIER setting, the highest frequency of the sweep display can be increased by 6 dB or decreased by 20 dB, referenced to the lowest frequency of the sweep display. Rear panel controls include an ON/OFF switch and a variable TILT control.

1.4 ACCESSORIES

1.4.2 Accessories Available:

- Wide Band RF Detectors Model D151 for 50 ohm impedance and Model D171 for 75 ohm impedance (both have BNC connectors)
- Rack Mount Kit K015 enables unit to be mounted in a 19" wide rack.

OPERATING INSTRUCTIONS

2.1 INTRODUCTION

This section covers electrical and mechanical installation, description of front and rear panels, instructions for operation and external programming.

2.2 INSTALLATION

2.2.1 Mechanical Installation

INITIAL INSPECTION

After being unpacked, the instrument should be inspected for physical damage. A procedure for checking the electrical performance is given in Section 4. The shipping container and packing material should be saved in case it becomes necessary to reship the unit.

If the unit is damaged or does not meet its electrical performance specifications, notify the nearest Wavetek area representative or the factory in Indiana. If the shipping container shows damage, notify the carrier. Retain the shipping container and packing material for the carrier's inspection. In either case, the factory or area representative will arrange for immediate repair or replacement of the instrument without waiting for damage claim settlements.

RACK MOUNTING

The K015 rack mount kit makes it possible to mount the unit in a standard 19" wide instrument rack. The kit includes the parts listed in Table 2-1.

To rack mount unit, first fasten both sides (items B,D) to bottom tray (item C) using screws provided with kit (item E) as shown in Figure 2-1. Position instrument on the tray so that the feet

TABLE 2-1. K015 Parts List

Item	Description	Wavetek P/N	TQ
A	Top Tray	C001-384-2	1
B,D	Side	C001-383	2
C	Bottom Tray	C001-384-1	1
E	Screw, 6-32x3/8"	HS101-606	12
F	Handle	HH101-000	2
G	Screw, 10-32x1/2"	HS103-908	4

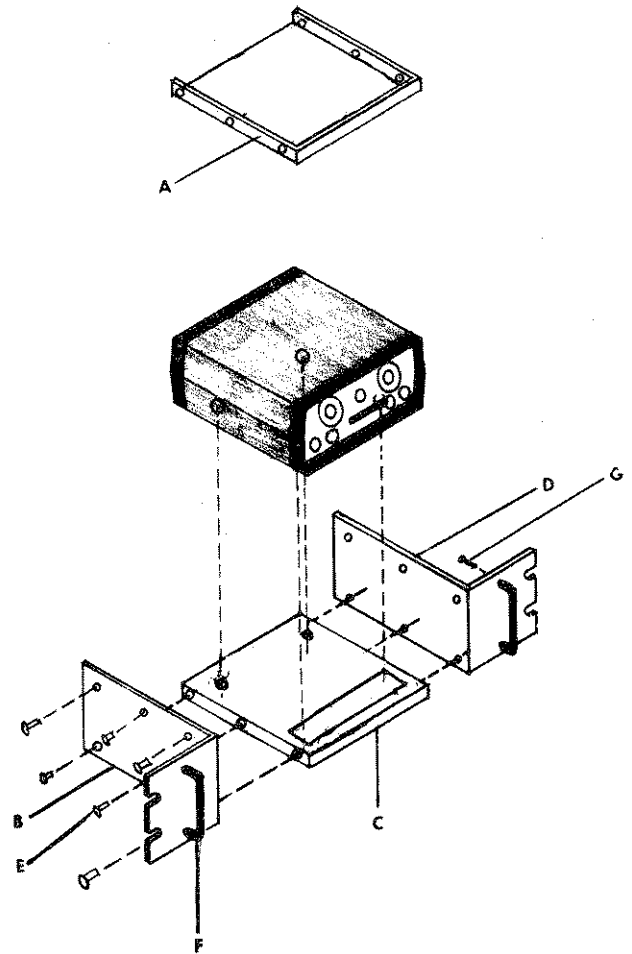

Figure 2-1. Rack Mounting

fit into the provided holes. Fasten top tray with remaining screws.

2.2.2 Electrical Installation

This instrument operates from either 115 volt AC or 230 volt AC supply mains as selected by a slide switch located on the rear panel. Before operating the instrument, check that the fuse mounted in the rear-panel fuse holder corresponds to the correct value for the selected voltage; i.e., $\frac{1}{2}$ amp for a 115 volt AC, and $\frac{1}{4}$ amp for 230 volt AC.

The power supply has been designed to operate from either 50 or 60 Hz supply mains.

Instruments are shipped from the factory for operation at 115 volt AC, 60 Hz unless specified for 230 volt AC, 50 Hz operation.

The electrical performance of this instrument should be verified. Performance checks for incoming inspection are given in Section 4, Maintenance.

2.3 DESCRIPTION OF FRONT PANEL

Refer to Figure 2-2.

- ① POWER ON/OFF switch applies AC line voltage to instrument power supply. Red LED light indicates power is on.
- ② FREQUENCY control adjusts center frequency of output.
- ③ VERNIER control provides fine adjustment of output center frequency.
- ④ SWEEP WIDTH control adjusts the range of frequency over which the instrument is sweeping. Full counter-clockwise rotation of this control will switch the instrument onto continuous wave operation.
- ⑤ OUTPUT STEP ATTENUATOR adjusts output in 10 dB steps.

- ⑥ OUTPUT VERNIER ATTENUATOR - adjusts output continuously over a 20 dB range (first 14 dB calibrated).
- ⑦ MARKER SIZE control adjusts size of marker display.
- ⑧ MARKER WIDTH control adjusts width of marker display.
- ⑨ MARKER switches turn indicated markers on or off.
- ⑩ SCOPE HORIZ OUT provides the horizontal signal for an oscilloscope display.
- ⑪ SCOPE VERT OUT provides the detected signal (with markers) for an oscilloscope display.
- ⑫ DEMOD IN accepts detected RF signal from external detector.
- ⑬ DETECTOR IN accepts RF signal and feeds it to the instrument's internal detector.
- ⑭ RF OUT provides the instrument RF sweep output.
- ⑮ SWEEP RATE control adjusts the repetition rate of the instrument sweep (Models 1062 and 1067 only).
- ⑯ TRIG / RECUR switch provides either continuous recurring sweep or single sweep operation (Models 1062 and 1067 only).

2.4 DESCRIPTION OF REAR PANEL

Refer to Figure 2-3.

- ① NOTCH FILTER controls provide adjustment of notch frequency (B2 option).
- ② TILT control adjusts degree of tilt of output (B3 option).
- ③ OPTION ON/OFF switch turns the installed options on or off (B2, B3 option).

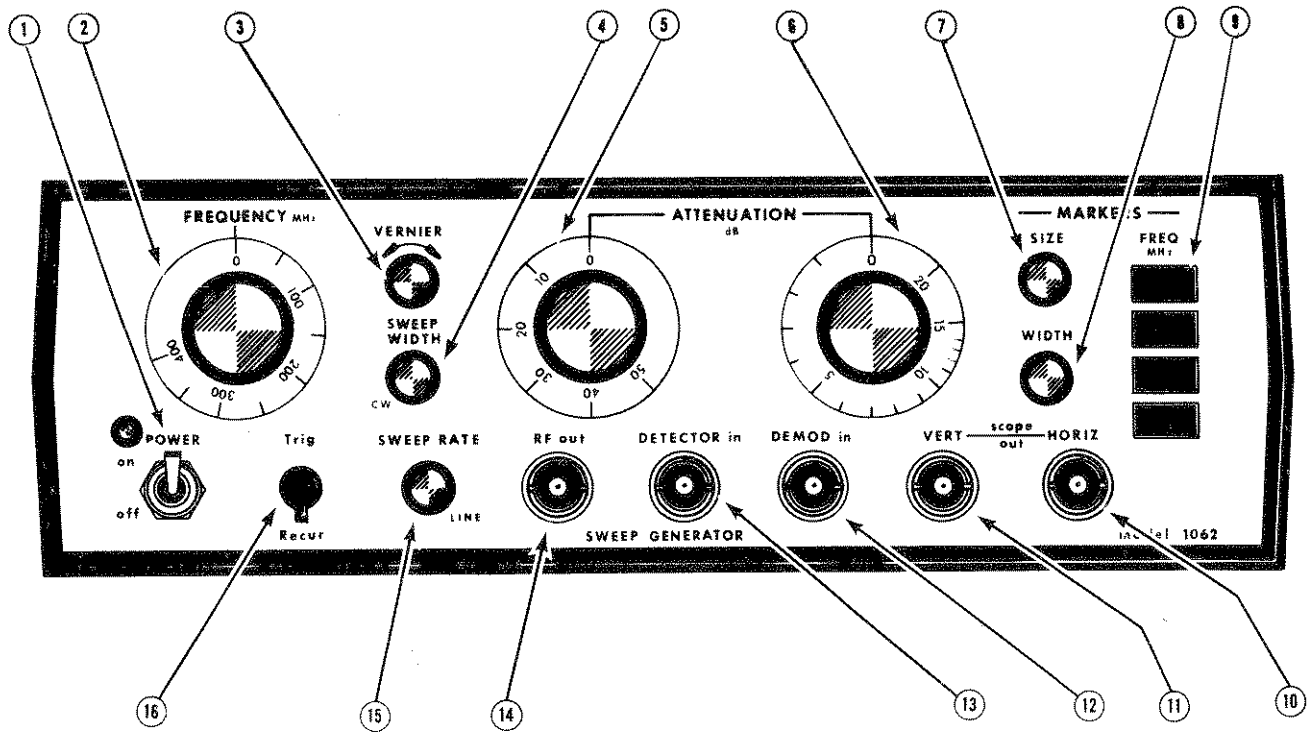

Figure 2-2. Front Panel

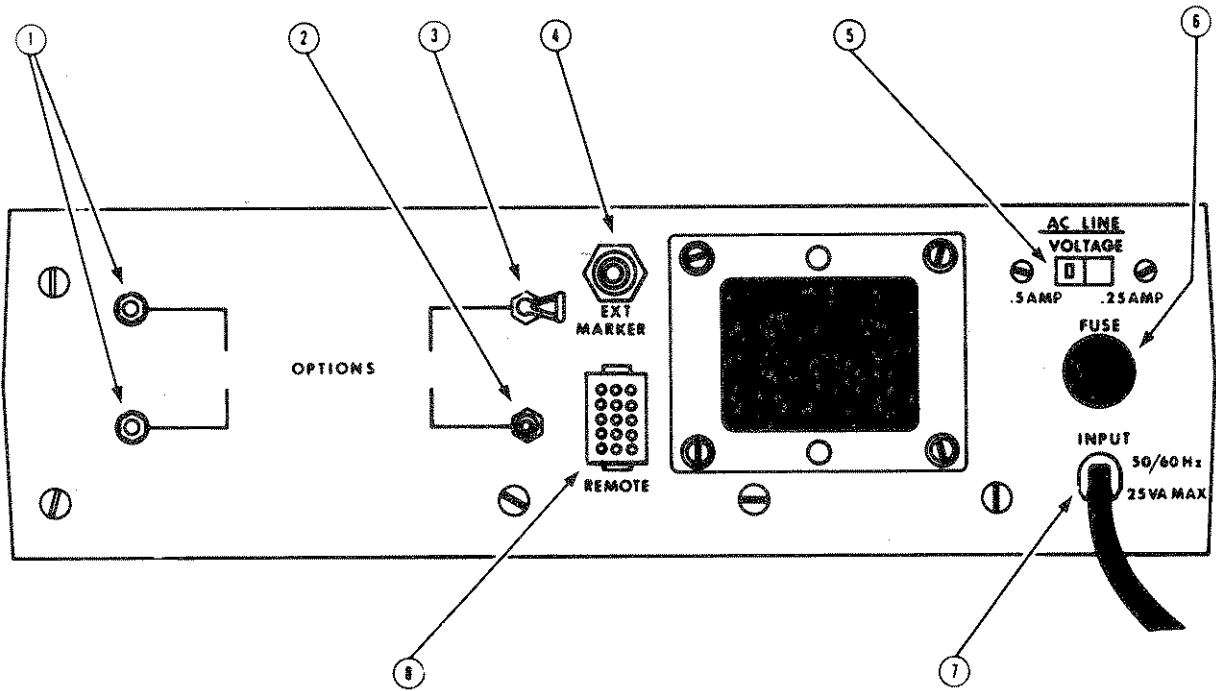

Figure 2-3. Rear Panel

- 4 EXT MARKER input accepts an external CW signal used to generate a marker at an externally determined frequency.
- 5 AC LINE switch selects 115 V or 230 V line operation.
- 6 AC LINE FUSE is $\frac{1}{2}$ amp for 115 V operation, $\frac{1}{4}$ amp for 230 V operation.
- 7 AC LINE INPUT connects instrument to AC mains via 3 prong plug.
- 8 REMOTE jack provides connections for remote control of center frequency, sweep width, and 0 to 20 dB of attenuation.

2.5 TYPICAL OPERATING SETUP

When initially setting up instrument, first check rear-panel AC LINE voltage selector switch and fuse to insure that the instrument is set for operation with the available AC mains.

Make connections between the Sweep Generator, the device under test and the oscilloscope as shown in Figure 2-4. Since hum, RF leakage and spurious signal pickup must be kept to a minimum, it is essential that good connections and grounds be maintained throughout the entire setup. Use coaxial cables with appropriate RF connectors wherever possible. The RF output cable is especially critical. It should match the output impedance of the sweep generator and should be kept as short as practical (under 3 feet). If the input impedance of the device under test is not the same as the sweep generator output impedance, a matching network (Figure 2-4) should be used to insure that a constant amplitude input signal is sent to the device under test.

After the RF signal passes through the RF circuit of the device under test, it must be demodulated before being displayed on the scope. If a detector is not part of the device under test, the RF signal can be detected by an external detector or the internal detector provided as part of the sweep generator.

External detectors are available from Wavetek for both 50 and 75 ohm applications (BNC connectors only).

When using the internal detector, the DEMOD IN connector should have no input connected.

If the detector being used is a high impedance detector or has a DC component, the internal detector must be disconnected from the DEMOD IN connector.

Switch POWER on. The red pilot light should light, indicating an operating condition.

(NOTE: This instrument does not require a warmup period unless it is to be used at the extreme limits of its specifications.)

After completing the setup, adjust the sweep generator controls for the required center frequency, sweep width and output amplitude. Turn the desired markers on, and adjust their size and width.

2.6 SPECIAL OPERATING NOTES

ERRORS FROM SWEEP RATE EFFECTS

When RF circuits having rapid amplitude changes are swept, errors may occur due to detector delays. Decreasing the detector output time constant will minimize this effect.

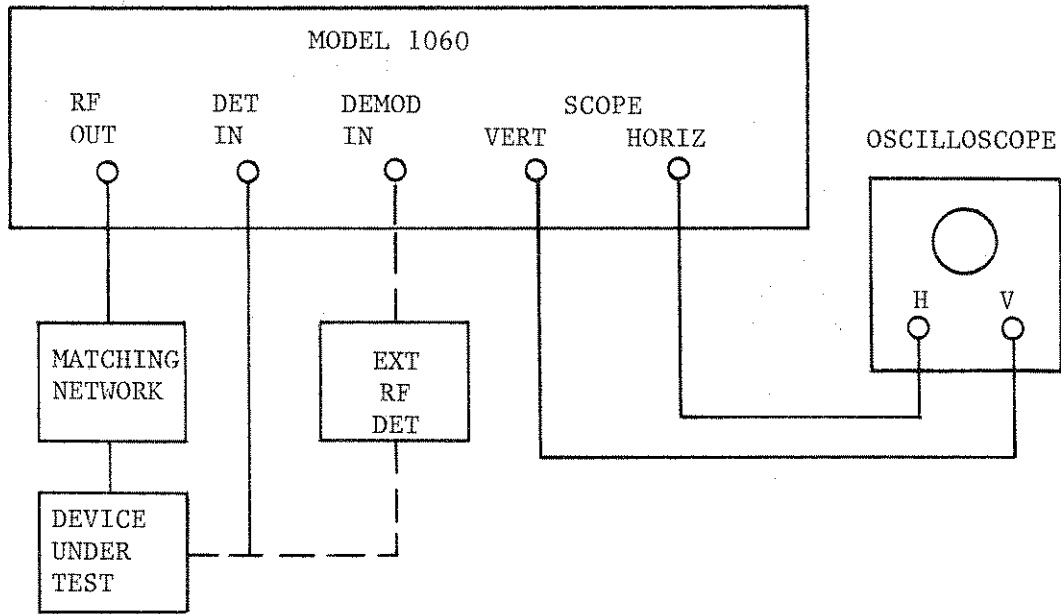

Figure 2-4. Typical Operating Setup

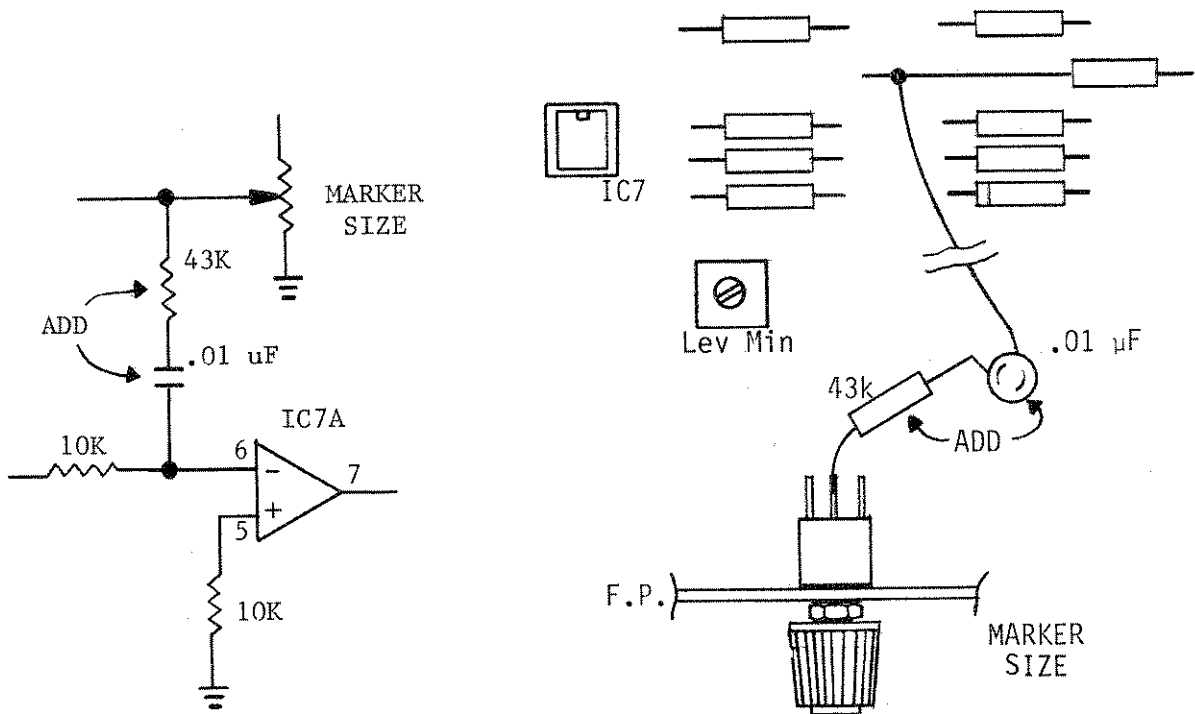

Figure 2-5. Marker Level Modulation Modification

EFFECT FROM OVERLOADING

The use of excessive input signals to the device under test can cause overloading, which yields a distorted response. To prevent this, first turn the attenuation controls to minimum output amplitude. Gradually increase the output amplitude until a response is obtained. Further increase of the output amplitude should not change the shape of the response envelope except in amplitude. If the response envelope does change (e.g., flatten at the top) decrease the signal just far enough to restore the proper shape.

MAKING MEASUREMENTS AT LOW LEVELS

When making measurements at low levels, radiation and ground loops are problems. Using double shielded cables for RF signals helps minimize the radiation problem. Ground loops causing hum pickup can sometimes be eliminated by completing only one ground connection between each instrument. This applies particularly to the oscilloscope. If the ground connection is made at the vertical input terminal, an additional ground at the horizontal input terminal will often result in hum pickup.

MARKER GENERATION BY LEVEL MODULATION

Birdy markers may be used to modulate the RF output signal. This permits viewing frequency markers on the detected response without having to return the detected signal to the marker adder in the sweep generator. This is useful when the detector and scope display are remote to the sweep generator.

In order to accomplish this, the instrument should be modified by adding a 43 kΩ resistor and a .01 uF capacitor in series between the wiper of the MARKER SIZE pot (front panel) and the inverting input (pin 6) of the Leveler IC on the PC Board. Refer to Figure 2-5 for suggested hookup.

Center Frequency
(F.P. FREQUENCY control set at 200 MHz)

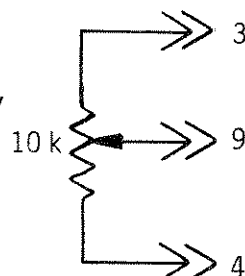

Sweep Width
(F.P. SWEEP WIDTH control set at 10 k min)

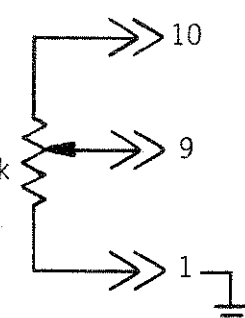

Output Amplitude
(F.P. OUTPUT VERNIER ATTENUATOR set at max)

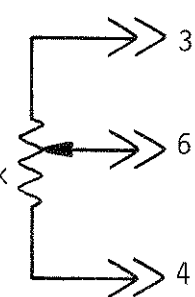

External FM

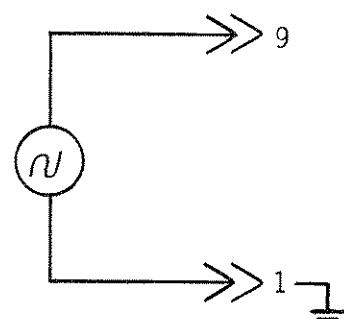

External AM

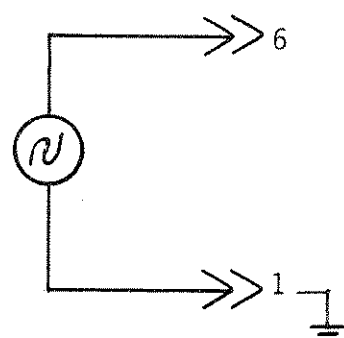

Figure 2-6. External Programming

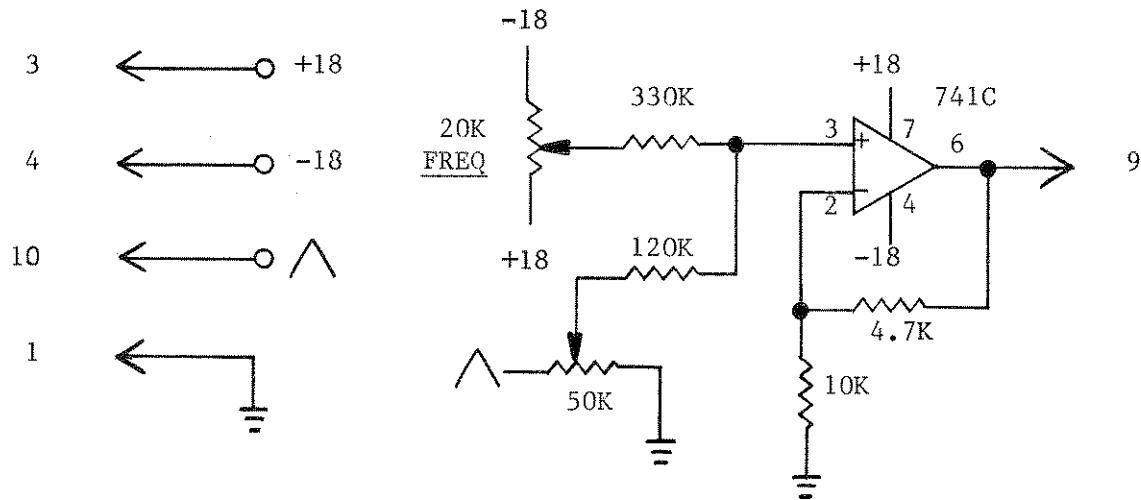

Figure 2-7. Suggested Active External Programming Circuit

2.7 EXTERNAL PROGRAMMING

The rear-panel REMOTE jack is provided for remote control of center frequency, sweep width, and output amplitude. A 10 kilohm pot should be wired as shown in Figure 2-6 in order to control the desired function. Front-panel controls must be set as indicated to allow proper operation of the remote controls.

If both center frequency and sweep width are to be remotely controlled, an active circuit, such as is shown in Figure 2-7, will be necessary.

NOTE

For external AM, the modulating signal is fed into the Level control, pin 6 (pin 1 is ground). For external FM, the modulating signal is fed into the Center Frequency control, pin 9. Refer to Section 1.2.5, Table 1-1 for External Modulation specifications.

2.8 OPTION B2 - PILOT CARRIER NOTCHES AND TILT CONTROL

This option generates pulses which blank the RF output at two frequencies within the instrument range. These pulses (notches) may be positioned at the pilot carriers for systems with fast AGC, or may be used as frequency markers at channel or band edges.

The option is put into operation by means of the rear-panel ON/OFF switch. The pulse (notch) frequency is set using NOTCH POSITION controls 1 and 2 on the rear panel. Notch Width can be adjusted from 3 to 10 MHz using internal adjustment R8.

This option also includes Option B3, Tilt Control, described in Section 2.9.

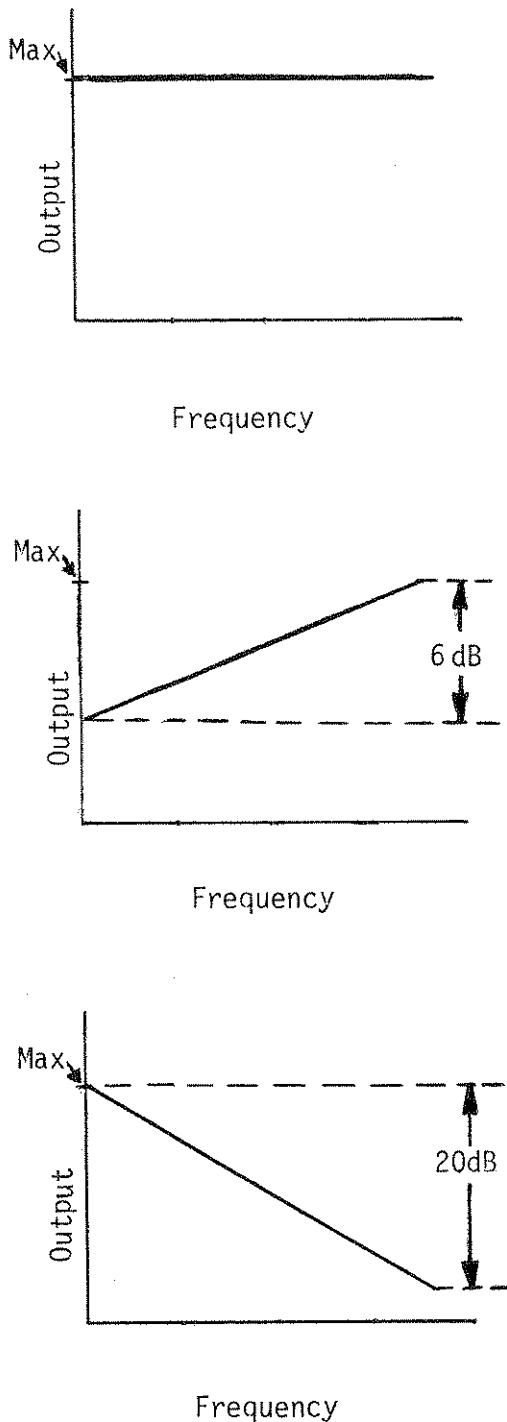

Figure 2-8. Instrument Output Using Tilt Control

2.9 OPTION B3 - TILT CONTROL

This option enables the RF output to be tilted in order to compensate for system tilt or to simulate cable losses.

The option is turned on with the rear-panel ON/OFF switch. The amount of tilt is determined by the rear-panel TILT control. The highest frequency of the sweep display may be increased by up to 6 dB or decreased by up to 20 dB, referenced to the lowest frequency of the display (See Figure 2-8).

The front-panel OUTPUT VERNIER ATTENUATOR must be adjusted such that the 20 dB OUTPUT VERNIER ATTENUATOR range is not exceeded at the high frequency end of the display.

EXAMPLES:

For a 6 dB increase of output at the high frequency end, the OUTPUT VERNIER ATTENUATOR must be set at +1 or less (Models 1066, 1067), or between 6 and 20 (Models 1061, 1062). For a 20 dB decrease, the OUTPUT VERNIER ATTENUATOR must be set at +7 (Models 1066, 1067), or at 0 (Models 1061, 1062).

NOTE

If a Model 1075 RF Comparator is being used in conjunction with a 1060 Series Sweep Generator, Option B3 is disabled.

SECTION 3

THEORY OF OPERATION

3.1 INTRODUCTION

This section includes a brief description of the main blocks of circuitry. This is followed by a more detailed description of each circuit. The physical location of modules and circuits is covered in Section 4 (Figures 4-5 and 4-9).

3.2 SIMPLIFIED BLOCK DIAGRAM

The main blocks of circuitry are shown in the Instrument Wiring Diagram in Section 5 of this manual, which also includes the schematic of the Main PC Board.

The swept RF output of the instrument originates in the Sweep Oscillator. The ramp voltage necessary to drive the Sweep Oscillator comes from the Sweep Drive circuit. The triangle wave for the SCOPE HORIZONTAL output and for the Sweep Drive circuit comes from the Sweep Rate circuit. The optional M6 marker modules generate birdy markers which are ultimately added to the demodulated RF signal and sent to the SCOPE VERTICAL OUTPUT. During the discussion of each circuit it may be helpful to refer to the appropriate schematic in Section 5.

3.3 POWER SUPPLY

T201 has two secondary windings to provide AC power to the two full wave rectifiers which supply approximately 30 VDC to the 18 V regulators. IC2 is a 3 terminal voltage regulator, and, with error amplifier IC1A, provides the regulated +18 V. This supply is protected against reverse voltage by CR7.

IC3 and IC1B supply the regulated -18 V. Reverse voltage protection is furnished by CR8. The +10 V supply is provided by regulator IC4, while -10 V is supplied by IC5, a unity gain inverting amplifier having a +10 V input.

The transformer secondary for the -18 V supply provides the line rate input for the Sweep Rate circuit.

3.4 SWEEP RATE

In Models 1061 and 1066, a Line Rate Card is provided. This circuit provides a line rate triangle wave and a synchronized square wave.

In Models 1062 and 1067, a Rate Generator Card is furnished. This circuit generates variable rate square and triangle waveforms. Front-panel switching provides recurring sweep or triggered mode operation.

3.4.1 LINE RATE CARD

The voltage from the transformer is clipped by CR1 and 2 and fed into comparator IC1A. A square wave is produced by the op amp alternately saturating at its positive and negative output levels ($\approx \pm 16$ V) as the input crosses zero volts. This signal provides blanking for the Oscillator Leveler and Sweep Oscillator circuits.

The blanking signal is integrated by IC1B which provides a +5 V to -5 V triangle wave. This signal is applied to the SWEEP WIDTH control as well as the SCOPE HORIZONTAL Output of the instrument.

3.4.2 RATE GENERATOR CARD

a). Line Rate

With the SWEEP RATE control in the LINE (detent) position, a trigger pulse (developed from the 27 VAC secondary of T201) initiates the comparator/integrator on one cycle of operation. At the end of the cycle there is a delay until the next trigger pulse arrives. Clamp control R18 determines this wait time.

b). Variable Rate

With the TRIG/RECUR control on RECUR, Sweep Rate control R101 controls the integrator charging time, thus determining the 2 to 60 Hz variable rate. R31 provides for calibration of the sweep rate.

c). Trigger

When the TRIG/RECUR switch is in the center position, and the SWEEP RATE control is not detented to LINE, the sweep is held off until a trigger pulse occurs. A pulse occurs when +10 V is momentarily applied to pin 7 of the rear-panel REMOTE jack or the TRIG/RECUR switch is manually pushed to the uppermost (momentary) position. One sweep cycle occurs for each trigger.

The output of comparator IC2A is a square wave that is used for blanking. The square wave is integrated by IC1 and its associated circuitry, thus providing the triangle wave for the SCOPE HORIZONTAL output and the Sweep Drive.

3.5 SWEEP DRIVE

The function of the Sweep Drive circuit is to convert the SWEEP WIDTH and CENTER FREQUENCY programs into the appropriate signal for driving the Sweep Oscillator module.

The CENTER FREQUENCY program and the triangle wave SWEEP WIDTH program are summed at the input of IC6A. The output signal (24 Vpp maximum) is applied to a shaping network which includes Q10 and CR10, 11, 12 and 13. Q10 is a constant

current source which ultimately determines the level at which the shaping diodes conduct. The potentiometers connected to the diodes are controls for "bending" the otherwise linear Sweep Drive ramp. This compensates for non-linearity of the varactor diodes in the Sweep Oscillator.

IC6B is a buffer which allows for calibration of the maximum amplitude of the Sweep Drive signal.

3.6 OSCILLATOR LEVELER

This circuit is an error amplifier for the Sweep Oscillator which keeps the RF amplitude constant over the frequency range. It also includes a VERNIER level control.

The inputs to the Leveler are a negative detected RF signal from the monitor diode in the Oscillator module and a DC level from the OUTPUT VERNIER ATTENUATOR. R82 determines the maximum voltage that can be applied from the OUTPUT VERNIER ATTENUATOR to the op amp. The setting of R85 becomes more relevant as the voltage from the OUTPUT VERNIER ATTENUATOR becomes less negative. IC7B compares its two inputs and amplifies any deviation of the monitor signal from a constant level. This provides current for the PIN diode attenuator in the oscillator. Q11, driven by the blanking signal, closes the feedback loop around the Leveler causing essentially zero gain. This prevents the Leveler from overdriving the PIN diode attenuator during instrument retrace when the monitor signal should be zero volts.

3.7 SWEEP OSCILLATOR (MODULE M9Y-1/M9YA-1)

The sweep signal on the 1060 series is generated by heterodyning the output of a UHF Sweep Oscillator circuit with the output of a 1 GHz fixed frequency (CW) oscillator in a diode mixer. The difference frequency in the 1 to 400 MHz range is amplified by 3 wide-band amp-

lifier stages. An electronic PIN diode attenuator, providing vernier RF level adjustment, is controlled by the Oscillator Leveler (Section 3.6) which is regulated by a voltage from the monitor diode.

The output of oscillator Q1, (approximately 1000 MHz) is coupled through inductor L2 to L3 which is tied to opposite terminals of the double-balanced mixer consisting of diodes CR1, 2, 3, and 4. Q11 sweeps a frequency of approximately 1000 MHz to 1400 MHz. The sweep drive voltage from pin 9 of the module is applied to the varactor diodes, decreasing their junction capacitance, thereby causing the oscillator frequency to vary from low to high. The Sweep Oscillator output is coupled to the other terminals of the double balanced mixer through inductor L11. The resultant difference frequency is then amplified in the 1 to 400 MHz range by the wide band preamplifier stage consisting of transistor amplifier Q2 and emitter followers Q3 and Q6. Transistor switches Q4 and Q5 provide RF blanking by turning off the wide-band preamplifier during sweep retrace time.

Two RF outputs are provided from the wide-band preamplifier. One output from Q6 (designated Sweep Sample) is coupled via R17 and C10 to a wide-band amplifier consisting of Q7, 8, 9, and Q16. Q16 is used as an emitter follower, and the output is provided at J2 as a source for the marker generating circuits. Another module output (Aux. RF) comes through the same wide-band amplifier, but Q16 is used in the common emitter configuration. This output is thus further amplified and is provided at J4 as a source for Option A4. IC1 and its associated circuitry make up a leveler for both the Sweep Sample and Aux. RF outputs. This circuit works in a manner similar to the Oscillator Leveler.

The other RF output signal from Q6 (designated RF Z50 for Models 1061, 1062, or RF Z75 for Models 1066, 1067)

is coupled through R18 and C8 to the electronic attenuator consisting of PIN diodes CR12 and CR13 which provide variable RF conduction proportional to the positive current supplied from the Leveler circuit. The monitor diode, CR14, near the RF output jack, provides to the non-inverting input of the Leveler, a negative DC voltage proportional to the RF output level. Three wide-band amplifier stages, Q12, Q13 and Q14 amplify the signal from the electronic attenuator by about 40 dB, with reduced frequency response below 1 MHz and above 400 MHz. Since the closed loop leveling system establishes zero impedance at the monitor point, R66 determines the output impedance.

3.8 LEVEL MODULATOR

The output signal level of the instrument may be externally modulated. The modulation signal is applied to pin 6 of the rear-panel REMOTE jack. This signal is then internally applied to the OUTPUT VERNIER ATTENUATOR control through Level Modulator IC7A, thus accomplishing level modulation of the RF output signal.

3.9 BIRDY AMPLIFIER

This circuit amplifies the small birdy signals from the M6 marker modules to a useable level for superimposing on the demodulated RF signal. Q1 and Q3 amplify the small (10 mV) signals from the M6 marker modules by about 7. The two inputs are added and fed to Op Amp Q4, 6, and 7 for further gain. The push-pull output stage then amplifies the signals to produce saturated birdies. R45 and 46 drop the signals to about 2 Vpp at the MARKER SIZE pot. Counterclockwise rotation of the MARKER WIDTH control tends to turn on Q5 and Q7, which respectively shunt and feed back the higher frequencies thus causing the birdies to be narrower.

3.10 INTERNAL MARKERS (OPTIONS A1 AND A2)

Single frequency markers (M6S) produce

single birdy markers at any desired frequencies of the sweep generator. Harmonic markers (M6H) produce birdy markers at the fundamental and every multiple of the fundamental frequency.

The M6 receives a sample of the swept RF signal from the sweep oscillator. When power is applied to the module, the birdy marker is generated and sent to the Birdy Amplifier circuit.

Each marker module contains a crystal oscillator, a mixer and a birdy preamp. The M6H also has a harmonic generating stage. The different crystal oscillators used can generate from 1 to 55 MHz CW. The M6S can generate a higher frequency birdy by taking a harmonic of the crystal frequency.

The output from the crystal oscillator (or harmonic generator) is combined with the sweep sample in the mixer stage. In the case of single frequency markers, the mixer includes a tuned circuit which selects the frequency from which the birdy will be generated. In the case of harmonic markers, the mixer is untuned. The mixer circuit is generally a diode mixer, although transistor mixers are sometimes used. A zero beat occurs when the swept signal frequency is the same as that of the CW signal. The difference frequency on either side of the zero beat is a swept low frequency signal. This signal is amplified in a stage having a bandwidth no greater than 800 kHz.

3.11 EXTERNAL MARKER (OPTION A3)

This module (M6C) generates a single birdy marker at the frequency of a CW signal which is provided externally.

The external CW signal is mixed with a sample of the swept RF signal from the sweep oscillator module. The resulting signal sweeps from high to low and a zero beat occurs at the point in time when the sweep sample frequency is the same as that of the CW. This signal then sweeps high in frequency. The lower frequency around the zero beat is

amplified by Q1 with a bandwidth of less than 800 kHz. This birdy marker is then sent to other circuitry for further amplification.

3.12 PULSE MARKERS (OPTION A4)

This module (M13J) generates up to 5 pulses between 35 and 52 MHz. These are generated by sweeping a set of crystal filters with the Aux. RF output from the M9Y-1/M9YA-1, detecting the response, and triggering a comparator to develop pulses. The pulse output is added to the detected RF response by means of the marker adder system.

3.13 PILOT CARRIER NOTCHES AND TILT CONTROL (OPTION B2)

The RF output is blanked at two adjustable frequencies. The limit comparators determine the width and location of the notch. The horizontal ramp causes the comparators to switch as they pass through preset limits - one limit being 0 V, the other determined by the Notch Width control. Notch position is determined by the rear-panel controls. The positive pulse output is added to the blanking signal through diodes CR1 and CR2, thus effectively blanking the output signal at the preset notch positions.

3.14 TILT CONTROL (OPTION B3)

The tilt circuit provides a ramp to the Level Programming input (pin 6 of the rear-panel REMOTE jack) causing a linear increase or decrease in output amplitude with respect to frequency. The amount of tilt (i.e. the actual change of the RF output at the highest frequency of the sweep display) does not change with sweep width.

The horizontal ramp is inverted and attenuated by IC1A, and is inverted again by IC1B. The outputs of IC1A and IC1B are summed across the rear-panel TILT control (R6) to determine the tilt circuit ramp.

The pivot point of the horizontal ramp is determined by Offset control R2.

SECTION 4

MAINTENANCE

4.1 INTRODUCTION

This section provides information for testing, calibrating and troubleshooting the sweep generator. The performance test is designed for incoming inspection and periodic evaluation. If performance is not to specifications, refer to the calibration information in *italics* which immediately follows a performance check. If no such information is given, the unit must be recalibrated at the factory.

4.2 SERVICE INFORMATION

4.2.1 Removal of Cabinet

Turn the unit upside down and remove the four screws in the bottom of the unit. Turn the unit right side up and lift off the top.

4.2.2 Module Servicing

Module Mounting - Modules are mounted on a side panel which can be lifted out when the two rear-panel screws are removed. This facilitates module check-out and maintenance under operating conditions. (See Figure 4-9).

Removal of Module - A module may be removed by removing any cables attached to the top of the module and removing the single hold-down screw from the bottom.

Removal of Module Cover - Remove all nuts and washers from the top of the module and slide the cover off.

Reinstalling Module - Before reinstalling the module, check the module pins for proper alignment, then carefully seat the module pins into the chassis socket and replace the hold-down screw to ensure a good ground connection between module and chassis.

Module Pin Number System - The module pins are numbered as shown in Figure 4-1. The module base mounting screws are located off center and are used as a reference for locating pin No. 1.

4.2.3 Component Lead Configurations

Transistor and I.C. lead configurations are shown in Figure 4-2.

4.2.4 Recommended Test Equipment

The test equipment recommended for servicing, troubleshooting and calibrating this instrument is shown in Table 4-1.

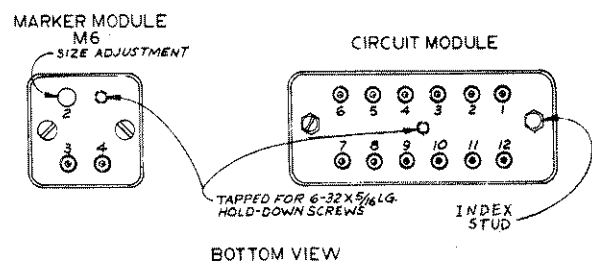

Figure 4-1. Module Pin Numbering

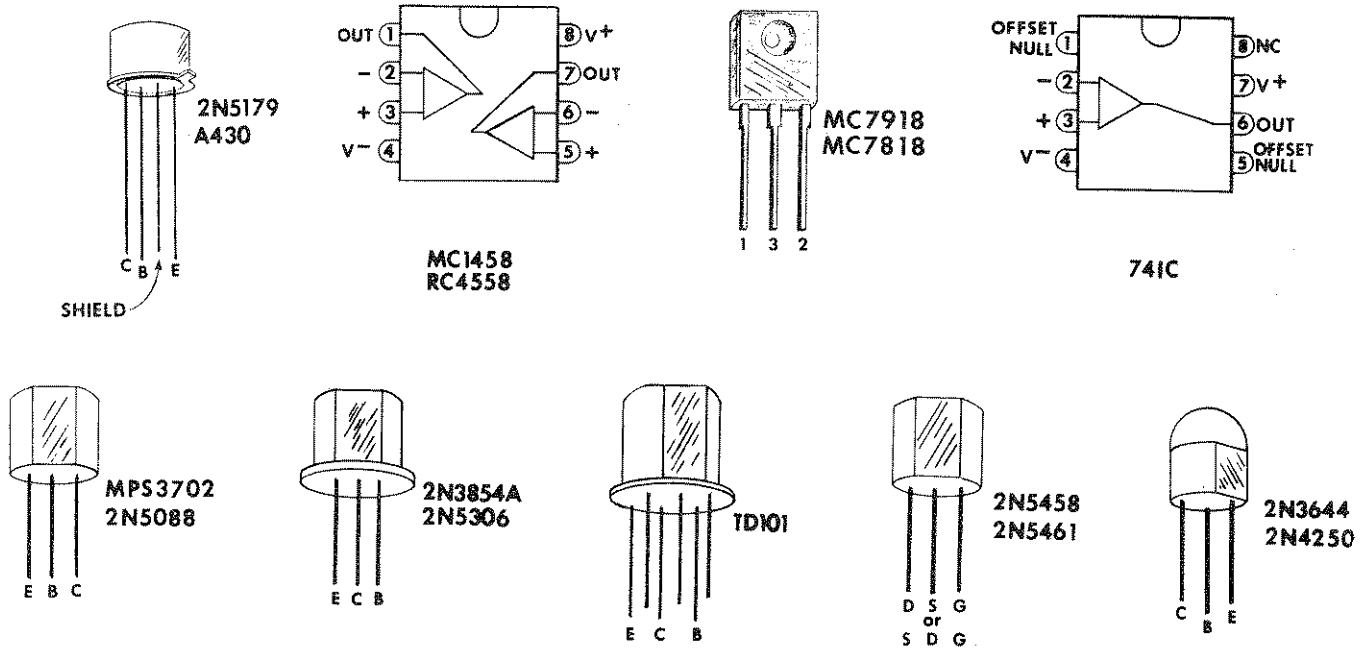

Figure 4-2. Transistor & IC Lead Configuration

TABLE 4-1. RECOMMENDED TEST EQUIPMENT

INSTRUMENT	CRITICAL REQUIREMENT	RECOMMENDED
Oscilloscope	DC coupled	Tektronix Series 5100
Digital Voltmeter	0.1% accuracy	Weston 1240
Power Meter	Frequency Range 10 to 1500 MHz	HP432A/478A
Spectrum Analyzer	Frequency Range 10 MHz to 3 GHz	HP8555A/8552A
Precision Attenuator Pads	10 dB 20 dB 40 dB	Weinschel 50-10 Weinschel 50-20 Weinschel 50-40
Matching Pad (75 ohm units only)	Minimum Loss 75 to 50 ohms	Wavetek M175

TABLE 4-1. Continued

Harmonic	1 MHz	Wavetek M6H-1
Marker	10 MHz	Wavetek M6H-10
Generators	50 MHz	Wavetek M6H-50
CW Signal Generator	Tunable to any frequency within the frequency range of the sweep generator. Accuracy ± 5 MHz Output 0.1 V	

4.3 PERFORMANCE CHECKS AND CALIBRATION

4.3.1 Introduction

The following procedure is intended to ensure that the instrument meets its published specifications. If it does not, it can be calibrated according to the instructions in *italics*. The checks specified assume that the instrument is equipped with A-2 options for markers at 1, 10, and 50 MHz. While it is possible to check the instrument's performance without the use of harmonic markers by using suitable external CW sources, a complete check by this method is impractical. The required performance is shown in Section 1.2, Specifications.

If calibration becomes necessary, remove the cabinet as instructed in Section 4.2.1. With the unit cover removed, all adjustments are accessible. Refer to Figure 4-5 for adjustments and test points.

In general, calibration must be performed in the sequence given.

4.3.2 Power Supplies

The +18 and -18 volt supplies are fixed voltage supplies, no adjustment is required. Check each to ensure that it measures between 17.8 and 18.2 volts. The +10 volt supply is adjustable, with the -10 volt supply following within 30 mV.

4.3.3 Horizontal Output Check

Adjust oscilloscope controls for an internally generated, automatic line triggered sweep of approximately 2ms/div and a vertical sensitivity of 2 V/div. Connect scope vertical input to instrument HORIZ output. Triangle wave should be symmetrical about zero with an amplitude of 10 Vpp (See Figure 4-3).

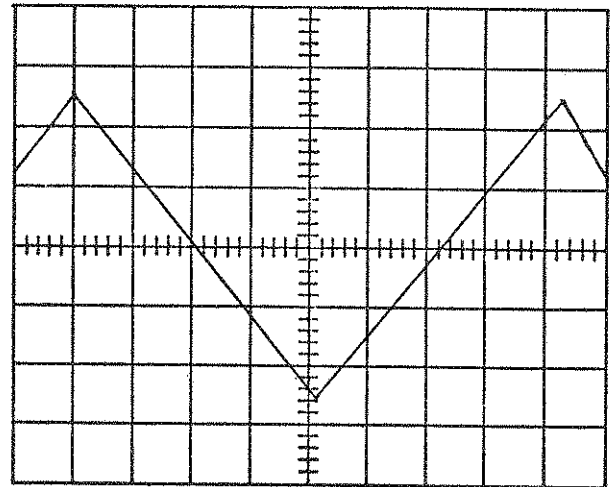

Figure 4-3. Horizontal Output

4.3.4 Frequency Program (Sweep Drive)

TYPICAL SETUP

Connect the sweep generator and scope as shown in Figure 4-4. Set the output frequency to 200 MHz. Set RF level to

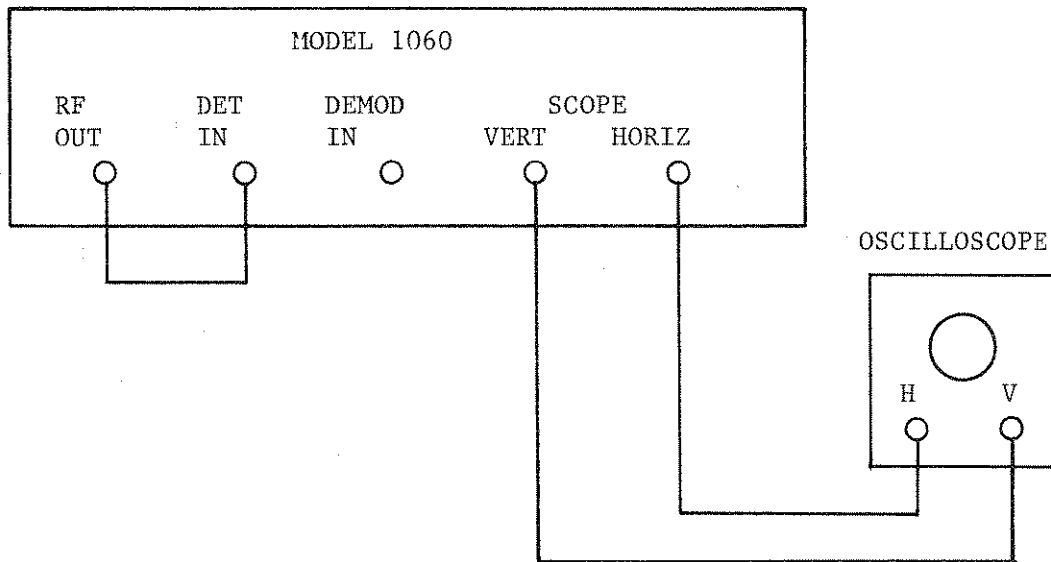

Figure 4-4. Typical Test Setup

maximum output (both STEP ATTENUATOR and OUTPUT VERNIER ATTENUATOR). Set the SWEEP WIDTH fully clockwise.

Adjust the scope to operate in an X-Y mode. Set the vertical sensitivity to 0.2 volt/div. Adjust the vertical position, horizontal position and horizontal sensitivity to obtain a scope pattern as shown in Figure 4-6.

Adjust the sweep generator marker controls as follows:

Turn on 50 MHz harmonic marker. Adjust MARKER WIDTH clockwise and MARKER SIZE to produce a marker amplitude similar to that shown in Figure 4-6.

DISPLAY LINEARITY

Display linearity is read directly from the display shown in Figure 4-6. Each marker must fall within 0.16 div of

a vertical line on the scope graticule. This is equivalent to a display linearity of 2%.

MAXIMUM SWEEP WIDTH

Maximum sweep width is also read directly from the display of Figure 4-6 and equals $((N-1)$ times the marker frequency) where N = number of markers present on the display (incl. Zero Beat).

FREQUENCY RANGE

To identify the frequencies shown on the display of Figure 4-6, one frequency marker must be positively identified. The Zero Beat in the swept RF output looks distinctly different than a marker, is present when other markers are off, and can be used as a frequency reference. The first 50 MHz birdy to the right of zero marks a frequency of 50 MHz, the second indicates 100 MHz, and so on. The frequency of each marker shown on the display can be identified by referring to the Zero Beat.

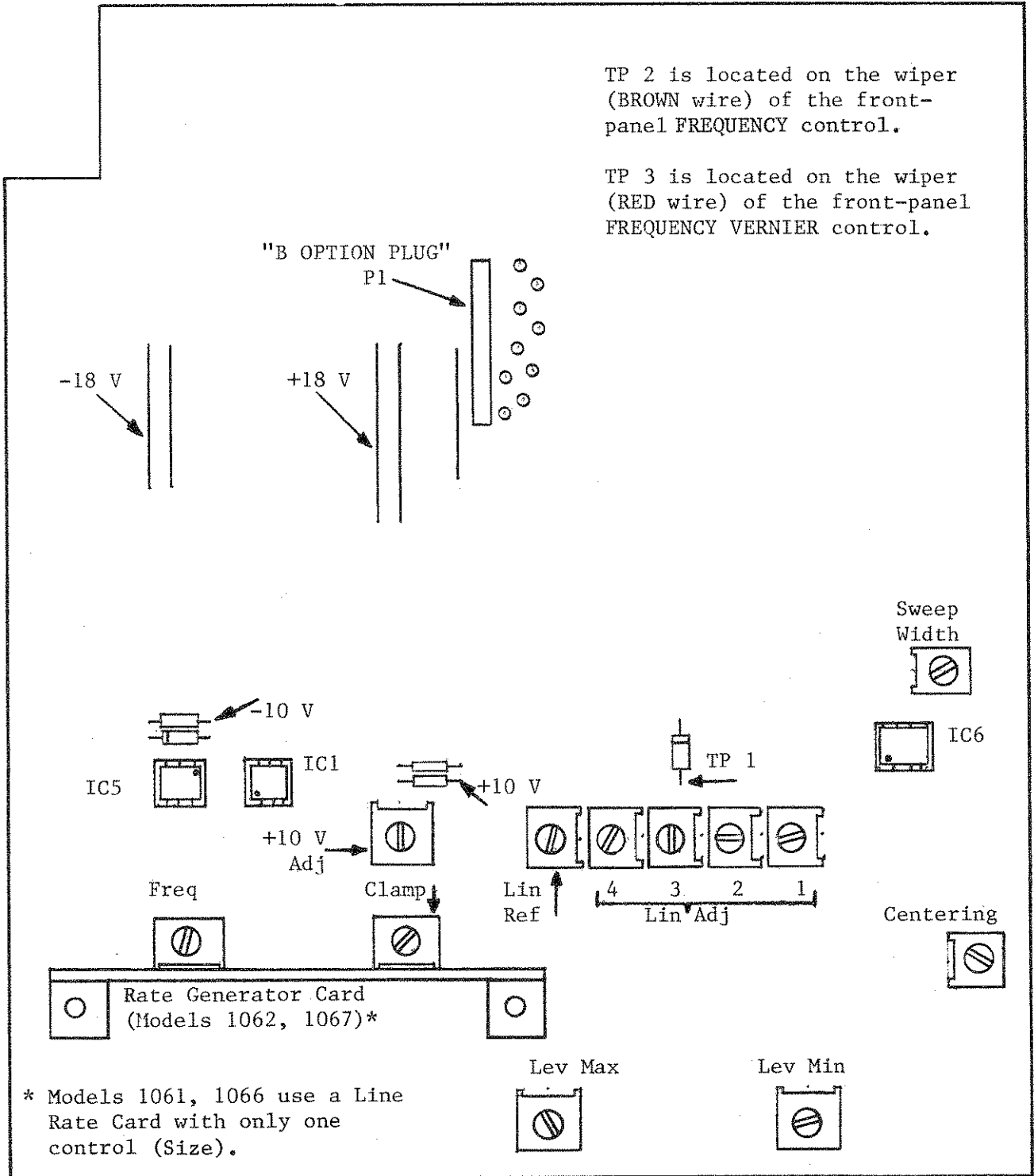

Figure 4-5. 1060 Series Control And Test Point Locations

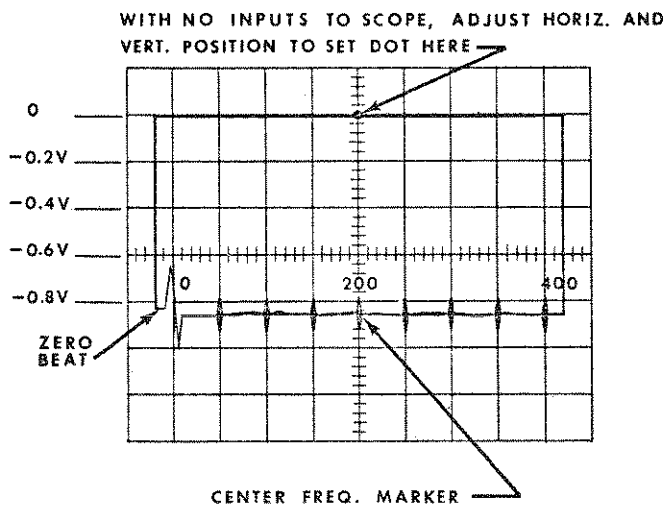

Figure 4-6. Detected RF With Markers

The center frequency range of the instrument can be checked by simply turning the FREQUENCY control to its extremes and noting the range of frequencies indicated at the exact center of the display. The low and high limit markers should move past the display center line by approximately $\frac{1}{2}$ div before the pot stops. This represents approximately 5% overrange capacity.

FREQUENCY DIAL ACCURACY

Set the calibrated FREQUENCY dial for zero MHz. Reduce the sweep width to approximately 50 MHz. With the 10 and 50 MHz harmonic markers on, check each of the lines on the dial against the actual center frequency of the output (as determined by the birdy marker display). The dial error is the difference between the actual frequency at the centerline of the scope and the frequency indicated on the dial. The dial accuracy is 5% of full scale or within 20 MHz of the dial setting.

MINIMUM SWEEP WIDTH CHECK

Turn the 1 MHz harmonic marker on. Adjust the FREQUENCY and SWEEP WIDTH controls to exactly center a 1 MHz harmonic marker on the extreme left scope graticule line and the next higher 1 MHz harmonic marker on the extreme right scope graticule line. See Figure 4-7.

The scope horizontal is now calibrated for 1 MHz full scale or 100 kHz per division. Adjust the FREQUENCY VERNIER to center a 1 MHz harmonic marker on the scope display. Adjust the MARKER WIDTH control to produce a Marker Width approximately equal to the minimum Sweep Width specification (200 kHz). Now decrease the Sweep Width to minimum and ensure that the points of the marker set for 200 kHz cover the entire scope display.

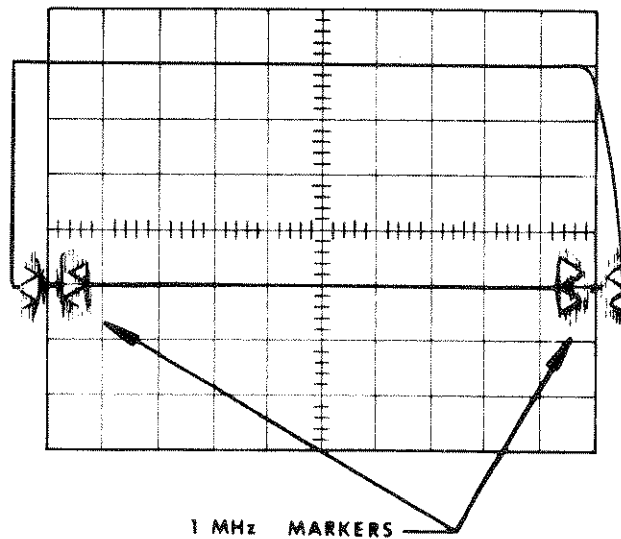

Figure 4-7. 1 MHz Sweep Width

CW MODE CHECK

Adjust the sweep width control fully counterclockwise until a "click" is heard. In this position the retrace blanking and the ramp component of the Sweep Drive signal are removed from the oscillator. The output frequency is determined by the FREQUENCY control and the accuracy is the same as in the above dial accuracy check. The output amplitude is the same as in the sweep mode of operation with the absence of the zero volt retrace reference.

If the instrument does not meet specifications according to above checks, the following calibration should be performed. Refer to Figure 4-5 for control and test point locations mentioned in the following procedure.

POWER SUPPLY

Connect a DVM to the +10 V TP. With the +10 V Adj control, set the voltage to 10.000 V. Measure also the -10 V, +18 V, and -18 V Test Points. The -10 V supply should read within 30 mV of the +10 V supply. The ± 18 V supplies should read within 0.2 V of the specified voltage.

SWEEP RATE

Connect the SCOPE HORIZONTAL output to the vertical input of the oscilloscope (scope set at 2 V/div vertical, 2 ms/div horizontal).

Models 1061, 1066 - Adjust the Size control on the Line Rate Card for a 10 Vpp signal.

Models 1062, 1067 - Set the SWEEP RATE control to a non-line rate. Positive and negative peak levels should be +5 V and -5 V respectively. Set the SWEEP RATE control to LINE. Set the Glamp control for -5 V. Set the scope for 1 ms/div. Adjust the Freq control such that the wait time between sweeps is 1 ms. The minimum non-line rate sweep time should be <16 ms. The maximum non-line rate sweep time should be ≥ 2 sec.

Set the instrument and scope up as described in the Typical Setup at the beginning of this section (4.3.4).

SWEEP DRIVE

Before starting, align the FREQUENCY control dial such that the marks on the dial beyond the 0 to 400 scale coincide with the dial's mechanical stops. Connect a digital voltmeter to TP2 and set the FREQUENCY control for electrical zero. Connect the DVM to TP 3 and set the FREQUENCY VERNIER for zero volts.

FREQUENCY PROGRAM AND LINEARITY

Connect the sweep generator and scope as shown in Figure 4-4. Set the vertical sensitivity of the scope for .2 V/div. Turn on a 50 MHz harmonic mar-

ker and electrically center the scope trace. Using a medium sweep width, adjust the Centering control to center the 200 MHz birdy on the screen. Set the FREQUENCY control to 0 MHz and center the Zero Beat on the screen using the Sweep Width control on the Main PC Board. Set the front-panel SWEEP WIDTH control to maximum. Reset the FREQUENCY control for electrical zero. Set the oscilloscope horizontal sensitivity such that the Zero Beat and the 200 MHz birdy are exactly 4 divisions apart. Connect the oscilloscope vertical to TP 1. Adjust the Lin Ref control on the Main PC Board such that the trace "knee" bends exactly 3 divisions beyond the 200 MHz birdy (Figure 4-8). Reconnect the oscilloscope vertical to the SCOPE VERT OUT connector and align the Zero Beat with the second vertical graticule line. Adjust Lin Adj controls 1, 2, 3, 4, in order, so that the 250, 300, 350, 400 MHz birdies, respectively, fall on graticule lines as shown in Figure 4-6.

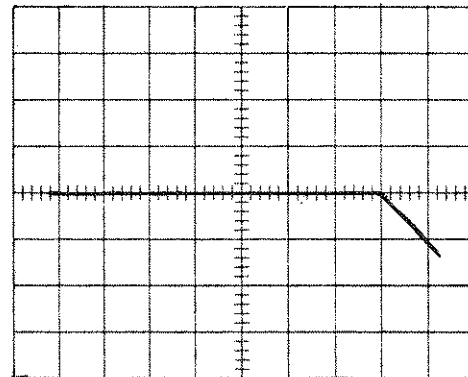

Figure 4-8. Linearity Reference Adj.

4.3.5 RF Amplitude

OUTPUT LEVEL

Set FREQUENCY control to 200 MHz. Set SWEEP WIDTH control to CW mode. Set OUTPUT STEP and VERNIER ATTENUATORS for maximum output. Connect power meter to the RF OUT connector. NOTE: Before connection to power meter, Models 1066, 1067 require an "F to BNC" adapter (less than 3" cable) and a 75 to 50 Ω matching pad.

OUTPUT LEVEL ADJUSTMENTS

Set the front-panel controls for maximum output (+57 dBmV for Models 1066, 1067, +10 dBm for Models 1061, 1062). Set the SWEEP WIDTH control to CW. Adjust the Lev Max control on the Main PC Board for exactly +57 dBmV or +10 dBm output on the power meter (with the 75Ω to 50Ω matching pad, +57 dBmV registers as 2.5 dBm on the power meter). Set the OUTPUT VERNIER ATTENUATOR to -7 on Models 1066, 1067, to +15 on Models 1061, 1062. Adjust the Lev Min control for +43 dBmV on Models 1066, 1067, for -5 dBm on Models 1061, 1062 (with the matching pad, +43 dBmV registers as -11.5 dBm on the power meter).

NOTE

The Lev Max and Lev Min adjustments interact, therefore, the above procedure should be repeated until both levels are correct without adjustment.

Using the power meter, verify the OUTPUT VERNIER ATTENUATOR calibration at every 1 dB marking for the top 14 dB of its range.

For power calibration in the field, the internal detector in the instrument may be substituted for a power meter. The proper detector outputs are:

*OUTPUT VERNIER ATTEN. at max.....-0.8 V
OUTPUT VERNIER ATTEN. at min.....-40 mV*

FLATNESS CHECK

The sweep generator should be set up as outlined in Section 4.3.4.

The RF flatness of ±.25 dB is checked by comparing the minimum amplitude point to the maximum amplitude point.

STEP ATTENUATOR CHECK

The accuracy of the STEP ATTENUATOR can be measured by using a suitable Attenuation Test Set or by directly substituting

precision RF attenuator pads for each 10 dB step of the ATTENUATOR. The output through the precision pad is compared to the output through the instrument's corresponding ATTENUATOR pad. An RF detector can be used to recover the signal at levels down to approximately -40 dBm. Below this level an RF amplifier or sensitive receiver (spectrum analyzer) must be used. The difference between the two outputs represents the attenuator error. Maximum allowable error is two percent of the indicated attenuation. The error is that produced by the step attenuator alone and does not include the basic flatness or the OUTPUT VERNIER ATTENUATOR error.

4.3.6 Frequency Performance

FREQUENCY DRIFT CHECK

Return to typical setup of paragraph 4.3.4 and again calibrate the display's sweep width to 1 MHz as in the minimum sweep width check in Section 4.3.4. Position the marker to the exact center of the oscilloscope display and read frequency drift directly from the scope display by noting the change in the marker's position with time. Each division represents 100 kHz. When reading drift over long periods of time, calibrate the display sweep width to 5 MHz, using the 1 MHz harmonic markers. Next, turn off the 1 MHz marker and turn on the 50 or 10 MHz harmonic markers. Center a marker on the scope display. Read drift as before, except each division now represents 500 kHz.

After one-half hour warmup at a constant ambient and allowing a five minute stabilizing period after a frequency change, the maximum allowable drift is 100 kHz per 5 minutes or 2 MHz per 8 hours.

RESIDUAL FM CHECK

Adjust the horizontal gain of the oscilloscope for a full width (10 div) display. Adjust the SWEEP WIDTH and FREQUENCY VERNIER controls to position a 1 MHz birdy marker at each edge of

the display (1 MHz sweep width). Use the FREQUENCY VERNIER to center a birdy on the screen. Set the SWEEP RATE to maximum (Models 1062, 1067). The birdy "wobble" should be less than 0.2 div (20 kHz at 100 kHz/div).

SPURIOUS SIGNAL CHECK

Checking for spurious signal content is not normally required for periodic calibration, only for incoming inspection. The only practical way to measure spurious signal content is with a high quality spectrum analyzer useable from 10 MHz to at least 800 MHz. The spurious check is made in accordance with the instructions furnished with the particular spectrum analyzer being used.

Spurious signals should be more than 30 dB below the amplitude of the fundamental frequency (10 to 400 MHz.)

The heterodyning method of generating the output signal will give non-harmonically related spurious signals in addition to the harmonically related signals. These signals are typically 40 to 50 dB below the output signal and should increase to no more than -30 dB near the high end of the frequency range.

4.3.7 Marker System

Specifications, with the exception of spurious markers, are the same for either single frequency or harmonic type markers. The procedure for verification of performance is the same for each type.

Single frequency markers should have no spurious markers throughout the swept range. Harmonic type markers may or may not have small spurious markers at one half or one third the specified marker interval.

SWEEP SAMPLE

Connect the RF detector (D151) to the sweep sample output jacks of the M9Y-1/M9YA-1 using 50 ohm coax and appropriate connectors. The detected value should be 30 millivolts and 130 mV at J2 and J4 respectively.

Sweep sample can be adjusted by removing the cover from the M9Y-1/M9YA-1 and turning the level control (R30) which is located at the top of the module on the front.

MARKER SIZE

Observe the markers and insure they are of equal amplitude throughout the range.

Set the oscilloscope vertical gain to 2 V/div and adjust the MARKER SIZE control fully clockwise. The markers should be approximately 2 V peak-to-peak in amplitude. Adjust the MARKER SIZE control fully counterclockwise and set the oscilloscope vertical gain to 5 mV/div. The markers should be less than 2 mV peak-to-peak in amplitude.

MARKER SIZE ADJUSTMENT - MODULE M6

Each marker module has a Size Adjustment control which is accessible from the side of the unit next to the marker module hold-down screw (refer to Figure 4-1). The control is adjusted until a saturated marker is obtained on the scope display when operating the unit as shown in the Typical Setup, Figure 4-6. A saturated marker is obtained when a further increase in the marker module Size Adjustment does not increase the marker amplitude on the scope display. Increasing the Size Adjustment beyond this point may result in spurious markers on the display.

MARKER WIDTH

While observing a birdy at a narrow sweep width, rotate the MARKER WIDTH control. There should be 3 distinct positions of the control and 3 distinguishable corresponding marker widths.

MARKER ACCURACY

Marker accuracy may be verified by one of several methods. The first method requires a signal generator, a frequency counter covering the desired marker frequency and an M6C, External Marker module. First adjust the sweep generator's center frequency to the marker's

frequency and the sweep width to approximately 2 MHz. Connect the output from the signal generator to the EXTERNAL MARKER connector located on the rear panel and carefully adjust the signal generator for a zero beat with the internally generated birdy marker. Next, connect the signal generator's output to the counter and read the signal generator frequency which is now identical to the marker frequency. Allowable error is 0.005% of the marker frequency.

The second method uses the counter only but requires the removal of the instrument cover and marker module cover.

Probe the marker box with the input lead from the counter until sufficient signal is picked up to provide a counter reading.

The highest crystal frequency used is approximately 50 MHz. Markers above this frequency use harmonics of the crystal frequency. Again the allowable error is 0.005% of the marker frequency. Test equipment for the marker accuracy check is not listed in the recommended test equipment chart since the requirements vary with the method and the specific markers installed in the unit. Also, the inherent stability of the quartz crystal makes a marker accuracy check unnecessary in all but the most critical applications.

4.4 TROUBLESHOOTING

INTRODUCTION

Troubleshooting is, in general, a systematic process of elimination. A thorough understanding of the circuit description located in Section 3 of this manual will enable the trouble symptom to be associated with a particular circuit function. Once this has been accomplished, the problem can be troubleshooted with the aid of the schematic. A problem in a power supply often causes many symptoms, and should be checked when the symptom does not clearly indicate a specific problem.

TROUBLESHOOTING HINTS

The following is a list of several typical symptoms followed by the probable cause or a troubleshooting procedure.

INTERMITTENT OPERATION OF ANY TYPE - Defective module pin sockets or loose RF cables.

NO RF OUTPUT - Defective ATTENUATOR or RF cables connecting to the input or output of the ATTENUATOR.

RF OUTPUT NOT FLAT - Most common cause is the RF detector being defective. The components in the internal detector circuit are easily accessible for repair. Another is the monitor diode located in the M9Y-1/M9YA-1. This is a point contact diode and can be damaged if the RF output is momentarily connected to a B+ voltage. (This is prevented in Models 1066, 1067 by the DC block in the RF output line.) A good monitor diode will produce a negative detected voltage approximately twice that of the external detector. For example, at maximum RF output an RF detector will read approximately 0.8 V. The internal monitor will read approximately -1.6 V.

FREQUENCY UNSTABLE (JITTER) - Check the M9Y-1/M9YA-1 module for a loose hold-down screw. Check the +10 V and +18 V supplies for excessive ripple. Operating the unit in a strong magnetic field, such as that adjacent to another instrument containing a large power transformer, can produce 60 Hz hum modulation.

NO RF SWEEP - First check the SCOPE HORIZONTAL connector for the presence of a 10 Vpp ramp. This ramp indicates proper operation of the sweep rate section. Next, check for the ramp at IC6, pin 1. Finally, check the Sweep Drive output of the PC Board at the input of the M9Y-1/M9YA-1 (pin 9). It should be similar to the SCOPE HORIZONTAL connector except it will be lower in amplitude, approximately 8 V

peak-to-peak. If the Sweep Drive output is correct, the trouble is probably in the M9Y-1/M9YA-1 sweep oscillator module.

MARKER PROBLEMS - A common marker problem is that caused by one of the interconnecting cables between the M6 modules being loose. This causes a notch in the sweep sample input to the module causing uneven harmonics or weak output from the M6.

To isolate the cause of a marker problem when the symptom does not clearly indicate a specific circuit or component, first check the sweep sample output at the M9Y-1/M9YA-1 sweep sample output connector (J2) using an RF detector. The detected signal should be approximately 40 mV. If the proper sweep sample signal is not present, it indicates that the trouble is in the Sweep Oscillator module. If signal is correct, connect the detector in place of the terminating plug, P301. A similar signal at this point indicates all jumper cables and RF jacks on the M6 modules are intact. Then check for the birdy output at pin 3 of the marker module (this is a Low Frequency signal). A 10 to 15 mV peak-to-peak birdy is sufficient to drive the birdy amplifier and indicates the M6 module is operating properly. With the 15 mV birdy present at the input of the birdy amplifier, a 5.5 V peak-to-peak signal should be produced at the output. This indicates proper operation of the birdy amplifier. The width of the output signal is controllable by the front-panel **MARKER WIDTH** control. The signal is now routed through the front-panel **MARKER SIZE** control and to the front-panel **SCOPE VERTICAL** connector.

4.5 MARKER INSTALLATION

Installing marker option involves plugging module into chassis, installing hold-down screw, connecting RF sweep sample, and installing the marker switch button.

Refer to Figure 4-9 for locations of marker positions b-f. M6S and M6H can be plugged in any of these 5 positions. Markers should be installed starting with position b and continuing in alphabetical order. The M6C should be plugged only in position a.

After plugging in modules, install hold-down screws as indicated in Figure 4-1.

Next, connect the sweep sample cable. This cable connects to the marker (usually an M6C) in position a (if there is no marker in position a, the sweep sample cable connects to the marker in position b).

The cable from the rear-panel **EXT MARKER** connector (if used) goes to the center connector of the M6C in position a.

Install 50 ohm termination on the unused connector of the last marker module.

Marker switch buttons are engraved to show the frequencies of the installed markers. Buttons can be replaced by pulling blank buttons off and pushing engraved buttons on the switches which turn on the corresponding marker frequencies.

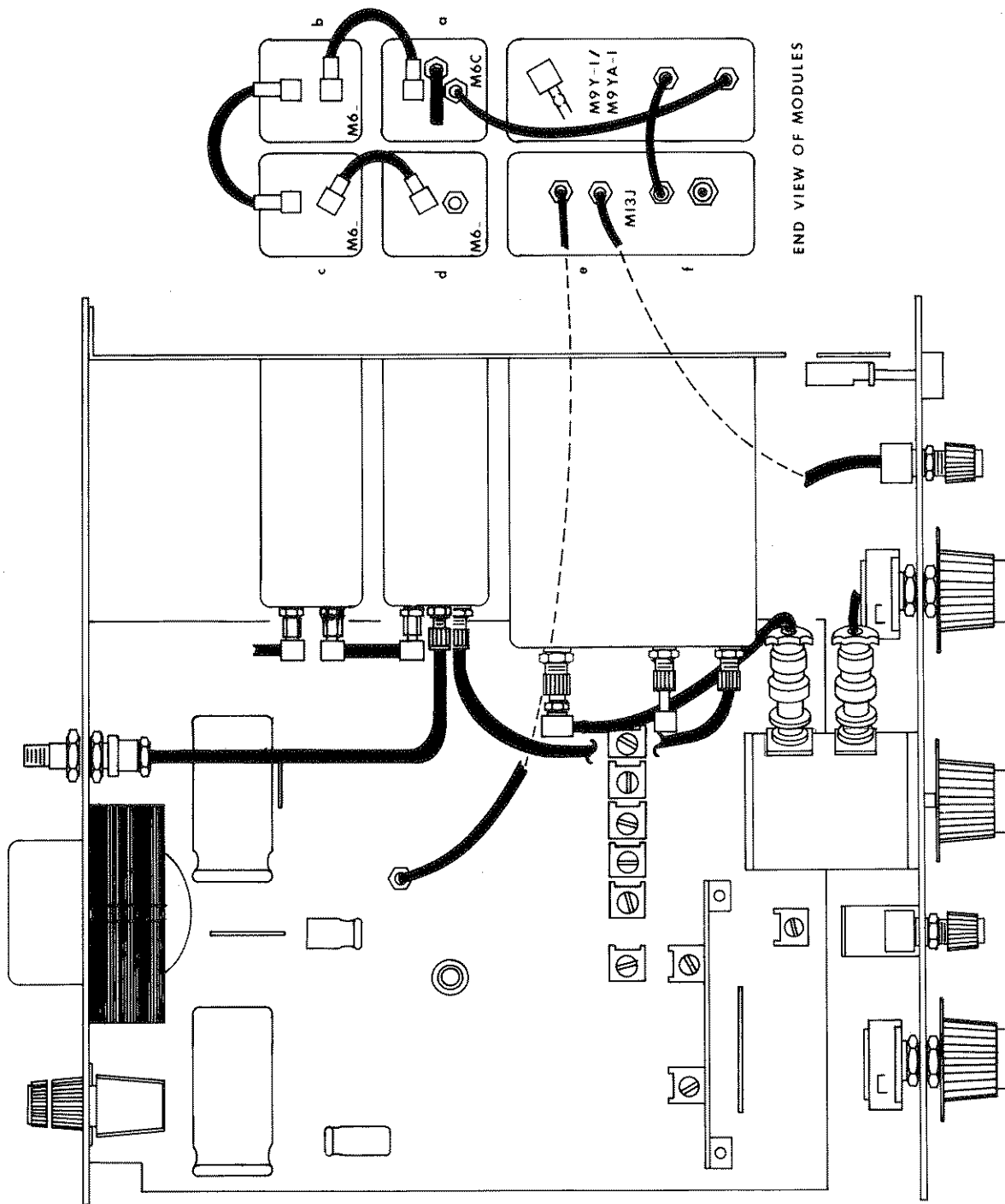

Figure 4-9. Top View

SECTION 5

REPLACEABLE PARTS

5.1 INTRODUCTION

This section contains lists of all replaceable parts for the instrument.

For an assembly containing one or more subassemblies, the assembly list appears first, and is followed by the subassembly lists.

The lists appear in the following order.

<u>PARTS LIST</u>	<u>ASSEMBLY</u>
1010-00-0075	1061
1010-00-0076	1062
1010-00-0077	1066
1010-00-0029	1067
-----	MISC. PARTS
1111-00-0019	MAIN FRAME
1111-00-0020	F.P. - 1061, 1062
1111-00-0022	F.P. - 1066, 1067
1219-00-0038	INT. DET. - 50 Ω
1219-00-0072	INT. DET. - 75 Ω
1110-00-0890	MAIN PC BOARD
1110-00-0900	C001 RATE CARD
1110-00-0970	C004 RATE CARD
1114-00-0070	M9Y-1 / M9YA-1
1114-00-0151	M13J
1110-00-1050	TILT
1110-00-1060	NOTCH / TILT
1114-00-0050	M6H-1
1114-00-0099	M6H-10
1114-00-0100	M6H-50
1114-00-0045	M6S-3
1114-00-0046	M6S-4
1114-00-0124	M6C

5.2 MANUFACTURERS CODE

The following code is used on the parts lists to identify the manufacturer.

MANUFACTURER ABBREVIATIONS

ABBRV	NAME	CITY	ST
A-B	ALLEN-BRADLEY	MILWAUKEE	WI
A-D	ANALOG DEVICES	CAMBRIDGE	MA
A-H	ARROW HART, INC.	KETTERING	OH
A-I	ALAN INDUSTRIES	COLUMBUS	IN
A-M	AMERICAN MAGNETICS	CARTERVILLE	IL
A-P	AMERICAN PLASTICRAFT CO.	CHICAGO	IL
ABAC	ABACUS PACKAGING CO.	CHICAGO	IL
ACI	ADVANCE COMPONENTS, INC.	CENTERBROOK	CT
AER	AVX CERAMICS	MYRTLE BEACH	SC
AERTK	AERTECH INDUSTRIES	SUNNYVALE	CA
AHAM	AHAM COMPANY	AZUSA	CA
AIN	ALPHA INDUSTRIES, INC.	WOBURN	MA
ALC	ALCO ELECTRONICS PRODUCTS	NORTH ANDOVER	ME
ALLPL	ALL PLASTICS, INC.	INDIANAPOLIS	IN
AMP	AMP, INC.	HARRISBURG	PA
APL	AMPHENOL CONNECTOR SYSTEMS	BROADVIEW	IL
APX	AMPEREX ELECTRONIC CORP.	SLATERSVILLE	RI
ARC	ARCO ELECTRIC PRODUCTS	SHELBYVILLE	IN
ASC	ASSOCIATED SPRING	BRISTOL	CT
ASE	AIRCO SPEER ELECTRONICS	ST. MARYS	PA
AT/IN	ATLANTIC INDIA RUBBER COMPANY	CHICAGO	IL
ATC	AMERICAN TECHNICAL CERAMICS	HUNTINGTON STATION	NY
ATR	ATR COIL CO.	BLOOMINGTON	IN
AUGAT	AUGAT, INC.	ATTLEBORO	MA
AVT	AVANTEK, INC.	SANTA CLARA	CA
AWC	ALPHA WIRE	ELIZABETH	NJ
B-T	BEK-TEK, INC.	READING	PA
BEK	BECKMAN INSTRUMENTS, INC.	FULLERTON	CA
BEL	BELDEN CORP.	GENEVA	IL
BER	BERG ELECTRONICS	NEW CUMBERLAND	PA
BGH	BEECH GROVE HARDWARE	BEECH GROVE	IN
BOU	BOURNS, INC.	RIVERSIDE	CA
BREZ	BREEZE CORPORATIONS, INC.	UNION	NJ
BUCK	BUCKEYE STAMPING CO.	COLUMBUS	OH
BUD	BUD RADIO, INC.	WILLOUGHBY	OH
BURND	BURNDY CORP.	NORWALK	CT
BUS	BUSSMAN MFG.	ST. LOUIS	MO
C-D	CORNELL DUBILIER ELECT. DIV.	NEWARK	NJ
C-E	CLINTON ELECTRONICS	ROCKFORD	IL
C-H	CUTLER-HAMMER, INC.	MILWAUKEE	WI
C-I	COMPONENTS, INC.	BIDDEFORD	ME
C-J	TRW/CINCH	ELK GROVE VILLAGE	IL
C-K	C & K COMPONENTS, INC.	WATERTOWN	MA
C-L	CENTRALAB DIV.	MILWAUKEE	WI
C-W	C-W INDUSTRIES	WARMINSTER	PA
CAM	CAMBION	CAMBRIDGE	MA
CAR	CARLING ELECTRIC, INC.	WEST HARTFORD	CT
CDC	COMPONENT DEVELOPMENT CORP.	CARSON	CA
CECO	CENTRAL COIL CO.	BRAZIL	IN
CGW	CORNING GLASS WORKS	CORNING	NY
CHE	CHERRY ELECTRICAL PRODUCTS	WAUKEGAN	IL
CIMCO	CIMCO WIRE AND CABLE INC.	ALLENDALE	NJ
CKI	CTS KNIGHTS, INC.	SANDWICH	IL

MANUFACTURER ABBREVIATIONS

ABBRV	NAME.....	CITY.....	ST
CLA	CLAIREX CORP.	MT. VERNON	NY
CLAR	CLAROSTAT MFG. CO	DOVER	NH
CLFX	COLE-FLEX CORP.	BABYLON	NY
CTS	CHICAGO TELEPHONE SYSTEMS	CHICAGO	IL
CTS-E	CTS OF ELKHART	ELKHART	IN
CTSBR	CTS OF BERNE	BERNE	IN
CTSBV	CTS OF BROWNSVILLE	BROWNSVILLE	TX
DAL	DALE TECHNOLOGY CORP.	HARTSDALE	NY
DAV	HARRY DAVIES MOLDING CO.	CHICAGO	IL
DEL	DELEVAN DIV.	EAST AURORA	NY
DEW	DEWIRE FABRICATING CORP.	LOWELL	MA
DIO	DIODES, INC.	CHATSWORTH	CA
DRA	DRAKE MANUFACTURING CO.	HARWOOD HEIGHTS	IL
E-C	ELECTRONIC CRYSTALS	KANSAS CITY	MO
E-M	ELECTRA/MIDLAND CORP.	MINERAL WELLS	TX
ELCO	ELCO INDUSTRIES	ROCKFORD	IL
ETP	ERIE TECHNOLOGICAL PRODUCTS	ERIE	PA
F-K	FROST-KING	****	**
F-S	FEDERAL SCREW	CHICAGO	IL
FAN	FANCOURT & CO.	GREENSBORO	NC
FCD	FAIRCHILD	MOUNTAIN VIEW	CA
FRTE	FAIR RITE PRODUCTS CORP.	WALLKILL	NY
G-E	GENERAL ELECTRIC	INDIANAPOLIS	IN
G-H	GRAYHILL, INC.	LA GRANGE	IL
G-I	GEN'L INSTRUMENT SEMICONDUCTOR	HICKSVILLE	NY
GAL	GALILEO ELECTRO-OPTICS	CARMEL	IN
GRIES	GRIES REPRODUCER	NEW ROCHELLE	NY
GRIP	GRIPMASTER CO.	MARLBORO	NJ
GUDL	GUDEBROD BROS. SILK CO.	CHICAGO	IL
H-P	HEWLETT-PACKARD	INDIANAPOLIS	IN
HEL	HELIPOT	ANAHEIM	CA
HEY	HEYMAN MFG. CO.	WAUKESHA	WI
HHS	HERMAN H. SMITH, INC.	BROOKLYN	NY
HIT	HITACHI AMERICA, LTD.	SAN FRANCISCO	CA
HOLUB	HOLUB DISTRIBUTING CO.	NEWPORT	KY
HUD	HUDSON TOOL & DIE CO.	NEWARK	NJ
HY/PL	HYDRO PLASTICS INC.	GEORGETOWN	KY
HYT	HYTRONICS	PINELLAS PARK	FL
INT	INTERSIL, INC.	CUPERTINO	CA
IRC	INTERNATIONAL RESISTANCE CO.	PHILADELPHIA	PA
ITT	INT'L TELEPHONE & TELEGRAPH	W. PALM BEACH	FL
JAN	JAN HARDWARE MFG. CO.	LONG ISLAND CITY	NY
JEF	JEFFERS	DUBOIS	PA
JEFWC	JEFFERSON WIRE AND CABLE	WORCHESTER	MA
JEW	JEWELL ELECTRICAL INSTRUMENTS	MANCHESTER	NH
JON	E.F. JOHNSON CO.	WASECA	MN
K-L	KERRIGAN LEWIS MFG.	CHICAGO	IL
K-S	K & S ENGINEERING CO.	CHICAGO	IL
KEENE	KEENE CORP.	NEWARK	DE
KEM	KEMTRON ELECTRON PRODUCTS	NEWBURYPORT	MA
KEY	KEYSTONE ELECTRONIC CORP.	NEW YORK	NY
KID	KIDCO, INC.	MEDFORD	NJ
KIN	KINGS ELECTRONICS	TUCKAHOE	NY

MANUFACTURER ABBREVIATIONS

ABBRV	NAME	CITY	ST
KSTR	KESTER SOLDER DIV.	CHICAGO	IL
KSW	KSW ELECTRONICS	INDIANAPOLIS	IN
LEYSE	LEYSE ALUMINUM CO.	KEWANEE	WI
LIT	LITTELFUSE, INC.	DES PLAINES	IL
LRC	LRC ELECTRONICS, INC.	HORNELL	NY
M-A	MICROWAVE ASSOCIATES	BURLINGTON	MA
M-D	MILLER DIAL & NAMEPLATE CO.	EL MONTE	CA
M-E	MEPCO ELECTRA, INC.	MORRISTOWN	NJ
M-O	ILLUMINATED PRODUCTS INC.	SANTA ANA	CA
MAL	MALLORY CONTROLS CO.	FRANKFORT	IN
MAND	MANDIX	CHICAGO	IL
MDC	MAIDA DEVELOPMENT CO.	HAMPTON	VA
MILN	MILLEN MFG. CO.	NEW YORK	NY
MMM	3M COMPANY	ST. PAUL	MN
MOL	MOLEX PRODUCTS	LISLE	IL
MOT	MOTOROLA SEMI. PROD. DIV.	INDIANAPOLIS	IN
MSP	MICRO SEMICONDUCTOR CORP.	SANTA ANA	CA
MYERS	MYERS SPRING CO.	LOGANSPORT	IN
N-T	NATIONAL TEL-TRONICS	LAREDO	TX
NAT	NATIONAL SEMICONDUCTOR CORP.	SANTA CLARA	CA
NEC	NIPPON ELECTRIC CO.	TOKYO, JAPAN	**
NEW	NEWARK ELECTRONICS	INDIANAPOLIS	IN
NYLO	NYLOMATIC	MORRISVILLE	PA
O-G	OPTI-GAGE INC.	DAYTON	OH
O-S	OMNI SPECTRA INC.	FARMINGTON	MI
OHM	OHMITE MFG. CO.	SKOKIE	IL
OMEGA	OMEGA WIRE & CABLE	HARLEYSVILLE	PA
P-B	POTTER AND BRUMFIELD	PRINCETON	IN
P-C	POWER COMPONENTS	WOODLAND HILLS	CA
P-K	PARKER KALON CORP.	CLIFTON	NJ
P-T	PENN TUBE PLASTICS CO.	CLIFTON HEIGHTS	PA
PAND	PANDUIT CORP.	TINLEY PARK	IL
PARA	PARAMETRIC INDUSTRIES	NORTHFIELD	IL
PEC	PACIFIC ELECTRICORD CO.	GARDENA	CA
PEC	PACIFIC ELECTRICORD CO.	GARDENA	CA
PHC	PHILADELPHIA HANDLE CO.	CAMDEN	NJ
PLSSY	PLESSEY ENG.	SCHILLER PARK	IL
POM	POMONA ELECTRONICS CO., INC.	POMONA	CA
PRMD	PYRAMID INDUSTRIES, INC.	PHOENIX	AZ
PRSN	PRECISION TUBE CO., INC	NORTH WALES	PA
PTN	PENN TRAN CORP.	BELLEFONT	PA
PYRO	PYROFILM CORP.	WHIPPANY	NY
PYTT	PYTTRONICS INDUSTRIES, INC.	MONTGOMERYVILLE	PA
Q-C	QUALITY COMPONENTS	ST. MARYS	PA
RAY	RAYTHEON	INDIANAPOLIS	IN
RCA	RCA	CAMDEN	NJ
REL	RELIANCE MICA CO.	BROOKLYN	NY
RICH	RICHCO PLASTIC CO.	CHICAGO	IL
RMC	RADIO MATERIALS CORP.	CHICAGO	IL
ROGAN	ROGAN CORP.	NORTHBROOK	IL
S-C	SPECIALTY CONNECTOR	INDIANAPOLIS	IN
S-G	STANDARD GRIGSBY	AURORA	IL
S-I	SWITCHCRAFT, INC.	CHICAGO	IL

MANUFACTURER ABBREVIATIONS

ABBRV	NAME	CITY	ST
S-S	SERVICE SUPPLY	INDIANAPOLIS	IN
S-T	SARKES TARZIAN	BLOOMINGTON	IN
SCC	STACKPOLE CARBON CO.	ST. MARYS	PA
SEAST	SEASTROM MFG. CO.	GLENDALE	CA
SEL	SEAELECTRO CORP.	MAMARONECK	NY
SEM	SEMTECH	NEWBURY PARK	CA
SGM	SIGMA INSTRUMENTS	BRAINTREE	MA
SHAM	SHAMROCK PLASTICS & RUBBER CO.	INDIANAPOLIS	IN
SIEM	SIEMENS	ISELIN	NJ
SIG	SIGNETICS CORPORATION	SUNNYVALE	CA
SOUTH	SOUTHCO FASTENERS	LESTER	PA
SPE	SPECTROL	DAYTON	OH
SPEC	SPECTRUM CONTROL. INC.	FAIRVIEW	PA
SPR	SPRAGUE ELECTRIC CO.	INDIANAPOLIS	IN
SSS	SOLID STATE SCIENTIFIC	MONTGOMERYVILLE	PA
STR	STETTNER TRUSH CO.	CAZENOVIA	NY
STSA	STEEL SALES	INDIANAPOLIS	IN
SYL	GTE SYLVANIA	WALTHAM	MA
SYS	SYSCON INTERNATIONAL, INC.	SOUTH BEND	IN
T-F	THERMA-FILM	****	**
T-I	TEXAS INSTRUMENTS	DALLAS	TX
TCPL	TACONIC PLASTIC	PETERSBURG	NY
TEK	TEKTRONIX	INDIANAPOLIS	IN
TELE	TELETYPE CORP.	ELK GROVE VILLAGE	IL
THR	THERMALLOY CO.	DALLAS	TX
TIMES	TIMES WIRE AND CABLE	CINCINNAI	OH
TIN	TINNERMAN PRODUCTS, INC.	CLEVELAND	OH
TKN	TECHNICAL WIRE	CRAWFORD	NJ
TLNC	TELONIC ALTAIR	LAGUNA BEACH	CA
TORCO	TOR CORP.	VAN NUYS	CA
TRU	WALDES TRUARC	LONG ISLAND CITY	NY
TRW	TRW CAPACITOR DIV.	OGALLALA	NB
U-C	UNIVERSAL COMPONENTS	LOS ANGELES	CA
UNIC	UNICORP	ORANGE	NJ
UNIT	UNITRODE CORP.	WATERTOWN	MA
USECO	USECO DIV.	VAN NUYS	CA
VAC	VACTEC INC.	MARYLAND HEIGHTS	MO
VAR	VARADYNE CAPACITOR DIV.	SANTA MONICA	CA
VARIL	VARI-L CO.	DENVER	CO
VLIER	VLIER ENGINEERING CORP.	BURBANK	CA
W-E	WELLS ELECTRONICS	SOUTH BEND	IN
W-I	WAVETEK INDIANA, INC.	BEECH GROVE	IN
WAG	WAGNER ELECTRIC CORP.	ST. LOUIS	MO
WECK	WECKESSER CO., INC.	CHICAGO	IL
WSD	WAVETEK	SAN DIEGO	CA
WSR	WAVETEK	SANTA ROSA	CA
ZEN	ZENITH RADIO CORP.	CHICAGO	IL
ZERO	ZERO MANUFACTURING CO.	BURBANK	CA
ZPT	ZIPPERTUBING, CO.	LOS ANGELES	CA

REFERENCE DESIGNATORS	PART DESCRIPTION	ORIG-MFGR-PART-NO	MFGR	WAVETEK NO.	QTY/PT
3	MAIN FRAME ASSY	A500-396	W-I	1111-00-0019	1
1	FRONT-PANEL ASSY 1061	A500-397	W-I	1111-00-0018	1
2	INT DET ASSY	A500-358-1	W-I	1219-00-0038	1
6	ATTEN, 5050-01	5050-01	W-I	1113-30-0021	1
7	MAIN BD ASSY	A530-002	W-I	1110-00-0890	1
8	RATE CARD,C004	AL540-004	W-I	1110-00-0970	1
5	SWP OSC,M9Y-1	M9Y-1	W-I	1114-00-0070	1
W1	CABLE ASSY,5 IN	WX2000-A3	W-I	1217-80-0001	1
W2	CABLE ASSY,7-1/2 IN	WX2000-A4	W-I	1217-80-0002	1
W3	CABLE ASSY, 6-3/4 IN	WX1067-W3	W-I	1217-01-0066	1
W4	CABLE ASSY,10 IN	WX1067-W4	W-I	1217-80-0014	1
9	SMC TERM,50 A500-267	A500-267	W-I	1118-00-0007	1
4	HARNESS ASSY	WY1061	W-I	1219-00-0045	1
WAVETEK PARTS LIST		TITLE SWP GEN,1061	ASSEMBLY NO. 1010-00-0075 PAGE: 1		REV

REFERENCE DESIGNATORS	PART DESCRIPTION	ORIG-MFGR-PART-NO	MFGR	WAVETEK NO.	QTY/PT
4	MAIN FRAME ASSY	A500-396	W-I	1111-00-0019	1
1	FRONT PANEL ASSY 1062	A500-398	W-I	1111-00-0020	1
2	INT DET ASSY	A500-358-1	W-I	1219-00-0038	1
8	ATTEN, 5050-01	5050-01	W-I	1113-30-0021	1
6	MAIN BD ASSY	A530-002	W-I	1110-00-0890	1
7	RATE CARD,C001	AL540-001	W-I	1110-00-0900	1
5	SWP OSC,M9Y-1	M9Y-1	W-I	1114-00-0070	1
W1	CABLE ASSY,5 IN	WX2000-A3	W-I	1217-80-0001	1
W2	CABLE ASSY,7-1/2 IN	WX2000-A4	W-I	1217-80-0002	1
W3	CABLE ASSY, 6-3/4 IN	WX1067-W3	W-I	1217-01-0066	1
W4	CABLE ASSY,10 IN	WX1067-W4	W-I	1217-80-0014	1
9	SMC TERM,50 A500-267	A500-267	W-I	1118-00-0007	1
3	HARNESS ASSY	WY1062	W-I	1219-00-0047	1
WAVETEK PARTS LIST		TITLE SWP GEN,1062	ASSEMBLY NO. 1010-00-0076 PAGE: 1		REV

REFERENCE DESIGNATORS	PART DESCRIPTION	ORIG-MFGR-PART-NO	MFGR	WAVETEK NO.	QTY/PT
3	MAIN FRAME ASSY	A500-396	W-I	1111-00-0019	1
1	FRONT-PANEL ASSY 1066	A500-399	W-I	1111-00-0021	1
2	INT DET ASSY	1219-00-0072	W-I	1219-00-0072	1
8	ATTEN, 7550-01	7550-01	W-I	1113-20-0029	1
6	MAIN BD ASSY	A530-002	W-I	1110-00-0890	1
7	RATE CARD,C004	ALS40-004	W-I	1110-00-0970	1
5	SWP OSC,M9YA-1	M9YA-1	W-I	1114-00-0071	1
W1	CABLE ASSY, 6 IN	WX1067-W1	W-I	1217-70-0010	1
W2	DC BLOCK, B173	B173	W-I	1113-80-0007	1
W3	CABLE ASSY, 6-3/4 IN	WX1067-W3	W-I	1217-01-0066	1
W4	CABLE ASSY,10 IN	WX1067-W4	W-I	1217-80-0014	1
9	SMC TERM,50 A500-267	A500-267	W-I	1118-00-0007	1
4	HARNESS ASSY	WY1061	W-I	1219-00-0045	1

WAVETEK PARTS LIST	TITLE SWP GEN,1066	ASSEMBLY NO. 1010-00-0077	REV
PAGE: 1			

REFERENCE DESIGNATORS	PART DESCRIPTION	ORIG-MFGR-PART-NO	MFGR	WAVETEK NO.	QTY/PT
3	MAIN FRAME ASSY	A500-396	W-I	1111-00-0019	1
1	FRONT-PANEL ASSY 1067	A500-400	W-I	1111-00-0022	1
2	INT DET ASSY	1219-00-0072	W-I	1219-00-0072	1
8	ATTEN, 7550-01	7550-01	W-I	1113-20-0029	1
6	MAIN BD ASSY	A530-002	W-I	1110-00-0890	1
7	RATE CARD,C001	ALS40-001	W-I	1110-00-0900	1
5	SWP OSC,M9YA-1	M9YA-1	W-I	1114-00-0071	1
W1	CABLE ASSY, 6 IN	WX1067-W1	W-I	1217-70-0010	1
W2	DC BLOCK, B173	B173	W-I	1113-80-0007	1
W3	CABLE ASSY, 6-3/4 IN	WX1067-W3	W-I	1217-01-0066	1
W4	CABLE ASSY,10 IN	WX1067-W4	W-I	1217-80-0014	1
9	SMC TERM,50 A500-267	A500-267	W-I	1118-00-0007	1
4	HARNESS ASSY	WY1062	W-I	1219-00-0047	1

WAVETEK PARTS LIST	TITLE SWP GEN,1067	ASSEMBLY NO. 1010-00-0029	REV A
PAGE: 1			

REFERENCE DESIGNATORS	PART DESCRIPTION	ORIG-MFGR-PART-NO	MFGR	WAVETEK NO.	QTY/PT
J102	HSG, MINI-LATCH, 7-PIN MC000-113	65039-030	BER	2113-10-0003	1
J103	HSG, MINI-LATCH, 16PIN MC000-115	65039-021	BER	2113-10-0005	1
J201	RECEPTACLE, MC000-016	03-06-1151	MOL	2113-03-0001	1
J202 P202	HSG, MINI-LATCH, 5-PIN MC000-111	65039-032	BER	2113-10-0001	2
J203	HSG, MINI-LATCH, 4-PIN MC000-120	65039-033	BER	2113-10-0006	1
J204	HSG, MINI-LATCH, 9-PIN MC000-121	65039-028	BER	2113-10-0007	1
RPLUG	PLUG, MC000-017	03-06-2151	MOL	2113-04-0001	1
NONE	TERMINAL, FEMALE MC000-018	1855	MOL	2113-05-0001	1
NONE	TERMINAL, MALE MC000-019	1854	MOL	2113-05-0002	1
NONE	TERM, MINI-PV MC000-092	47439	BER	2113-20-0001	1
NONE	TERM, MALE, MC000-116	48116	BER	2113-22-0001	1
NONE	PLUG, POLARIZING MC000-117	65307-001	BER	2113-23-0001	1
WAVETEK PARTS LIST		TITLE MISCELLANEOUS PARTS	ASSEMBLY NO. ----- PAGE: 1		REV

REFERENCE DESIGNATORS	PART DESCRIPTION	ORIG-MFGR-PART-NO	MFGR	WAVETEK NO.	QTY/PT
F201	FUSE, S.B., .5 AMP MF000-007	MDL 1/2	BUS	2410-05-0004	1
P205	POWER CORD, WL002-088	17237SVT	BEL	6011-80-0001	1
S201	SWITCH, DPDT, LOCKING SS000-003	46256LFE	S-I	5105-00-0003	1
S202	SWITCH, TOGGLE ST001-007	110-85	CAR	5106-00-0010	1
T201	XFMR, PWR, TT000-035	T1000-035	W-I	5610-00-0017	1
WAVETEK PARTS LIST		TITLE MAIN FRAME ASSY	ASSEMBLY NO. 1111-00-0019 PAGE: 1		REV C

REFERENCE DESIGNATORS	PART DESCRIPTION	ORIG-MFGR-PART-NO	MFGR	WAVETEK NO.	QTY/PT
C101	CAP,CER,120PF,1KV CD102-112	60U121M	MDC	1510-10-1121	1
CR101	LED DL000-001	NSL5046	NAT	4810-02-0001	1
J105 J106 J107	CONN,UG911A/U JB109-111	KC79-146	KIN	2110-01-1013	3
R101 (1062 ONLY)	POT/SWITCH RP152-310	70K1G040R103M	A-B	4610-30-4103	1
R102 R105 R107	POT,10K RP124-310	WA2G032S103MA	A-B	4610-10-7103	3
R103	POT/SWITCH RP151-310	70K1G04R103R	A-B	4610-30-3103	1
R104 R106	POT,10K RP118-310	JAIN056S103MA	A-B	4610-10-5103	2
R108	RES,C,1/4W,5%,33K RC103-333	CF1/4-33K	ASE	4700-15-3302	1
S101 (1062 ONLY)	SWITCH,TOGGLE ST002-006	7107PN-BLK	C-K	5106-00-0011	1
S104	SWITCH,PB,SZ000-020	PR10-304B	CTL	5110-00-0009	1
7	BUTTON,SW,SZ000-007	J52304-B	CTL	5110-04-0001	4
WAVETEK PARTS LIST		TITLE FRONT-PANEL ASSY 1061, 1062	ASSEMBLY NO. 1111-00-0020 PAGE: 1		REV

REFERENCE DESIGNATORS	PART DESCRIPTION	ORIG-MFGR-PART-NO	MFGR	WAVETEK NO.	QTY/PT
C101	CAP,CER,120PF,1KV CD102-112	60U121M	MDC	1510-10-1121	1
CR101	LED DL000-001	NSL5046	NAT	4810-02-0001	1
J105A J106A J107A	HOUSING, A001-503	A001-503	W-I	2111-06-0002	3
J105B J106B J107B	INSERT	1085-3	PRMD	2111-07-0001	3
R101 (1067 ONLY)	POT/SWITCH RP152-310	70K1G040R103M	A-B	4610-30-4103	1
R102 R105 R107	POT,10K RP124-310	WA2G032S103MA	A-B	4610-10-7103	3
R103	POT/SWITCH RP151-310	70K1G04R103R	A-B	4610-30-3103	1
R104 R106	POT,10K RP118-310	JAIN056S103MA	A-B	4610-10-5103	2
R108	RES,C,1/4W,5%,33K RC103-333	CF1/4-33K	ASE	4700-15-3302	1
S101 (1067 ONLY)	SWITCH,TOGGLE ST002-006	7107PN-BLK	C-K	5106-00-0011	1
S104	SWITCH,PB,SZ000-020	PR10-304B	CTL	5110-00-0009	1
8	BUTTON,SW,SZ000-007	J52304-B	CTL	5110-04-0001	4
WAVETEK PARTS LIST		TITLE FRONT-PANEL ASSY 1066, 1067	ASSEMBLY NO. 1111-00-0022 PAGE: 1		REV B

REFERENCE DESIGNATORS	PART DESCRIPTION	ORIG-MFGR-PART-NO	MFGR	WAVETEK NO.	QTY/PT
C102	CAP, FT, 500PF, 20% 250V CF104-150	4420-500PF	AER	1510-30-3501	1
C103	CAP, CER, .01MF, 100V CD103-310	68U103M	MDC	1510-10-2103	1
CR102	DIODE DG100-821	1N82AG	G-I	4807-01-0082	1
J108	RECEPTACLE, BNC FROM: 2110-01-1013	A001-228	W-I	1410-00-3579	1
R110	RES, C, 1/4W, 5%, 51 RC103-051	CF1/4-51	ASE	4700-15-5109	1
R109	RES, C, 1/4W, 5%, 33K	CF1/4-33K	ASE	4700-15-3302	1
WAVETEK PARTS LIST		TITLE INT DET ASSY 50 OHM	ASSEMBLY NO. 1219-00-0038 PAGE: 1		REV

REFERENCE DESIGNATORS	PART DESCRIPTION	ORIG-MFGR-PART-NO	MFGR	WAVETEK NO.	QTY/PT
C102	CAP, FT, 500PF, 20% 250V CF104-150	4420-500PF	AER	1510-30-3501	1
C103	CAP, CER, .01MF, 100V CD103-310	68U103M	MDC	1510-10-2103	1
CR102	DIODE DG100-821	1N82AG	G-I	4807-01-0082	1
J108A	HOUSING, A001-503	A001-503	W-I	2111-06-0002	1
J108B	INSERT	1085-3	PRMD	2111-07-0001	1
R110	RES, C, 1/4W, 5%, 75 RC103-075	CF1/4-75	ASE	4700-15-7509	1
R109	RES, C, 1/4W, 5%, 33K	CF1/4-33K	ASE	4700-15-3302	1
WAVETEK PARTS LIST		TITLE INT DET ASSY 75 OHM	ASSEMBLY NO. 1219-00-0072 PAGE: 1		REV

REFERENCE DESIGNATORS	PART DESCRIPTION	ORIG-MFGR-PART-NO	MFGR	WAVETEK NO.	QTY/PT
C01 C10	CAP,ELECT,1500MF,50V CE102-215	D76374	SPR	1510-20-1152	2
C02 C04 C07 C11 C14	CAP,CER,.005MF,1KV CD103-250	TG-050	SPR	1510-10-2502	5
C03 C09 C13 C15 C16 C18 C19 C22	CAP,TANT,10MF,25V CE120-010	162D106X00250D2	SPR	1510-21-7100	8
C05	CAP,ELECT,100MF,12V CE119-110	500D107G012CC7	SPR	1510-21-2101	1
C06	CAP,CER,100PF,1KV CD104-110	10TCU-T10	SPR	1510-10-3101	1
C08 C17	CAP,ELECT,100MF,25V CE105-110	TE1211	SPR	1510-20-4101	2
C20	CAP,CER,200PF,1KV CD102-120	5GA-T20	SPR	1510-10-1201	1
C21	CAP,CER,.001MFD,1KV CD102-210	5G4D10	SPR	1510-10-1102	1
C23	CAP,CER,.05MF,100V CD103-350	TG-S50	SPR	1510-10-2503	1
C24	CAP,CER,10PF,1KV CD101-010	10TCC-Q10	SPR	1510-10-0100	1
C27	CAP,CER,360PF,1KV CD102-136	60U361M	MDC	1510-10-1361	1
C28	CAP,CER,120PF,1KV CD102-112	60U121M	MDC	1510-10-1121	1
WAVETEK PARTS LIST		TITLE MAIN BD ASSY	ASSEMBLY NO. 1110-00-0890 PAGE: 1		REV B

REFERENCE DESIGNATORS	PART DESCRIPTION	ORIG-MFGR-PART-NO	MFGR	WAVETEK NO.	QTY/PT
C29	CAP,MON,1MF,50V,20%	3420-050-E105M	AER	1510-11-3105	1
C30	CAP,TANT,.47MF,50V CE113-447	935	TRW	1510-21-9470	1
CR01 CR02 CR03 CR04	DIODE DR000-008	1N5059	G-E	4806-01-5059	4
CR05 CR06 CR07 CR08 CR09 CR10 CR11 CR12 CR13 CR14 CR15	DIODE DR000-001	1N4004	P-C	4806-01-4004	11
IC1 IC6 IC7	IC,IC000-005	RC4558DN	RAY	7000-14-5800	3
IC2	IC,IC000-026	MC7818CD	MOT	7000-78-1800	1
IC3	IC,IL002-001	MC7918CP	MOT	7000-79-1800	1
IC4	IC,IC000-001	LM723CH	NAT	7000-17-2300	1
J104	CONN JF000-005	37JR116-1	S-C	2110-03-0002	1
P001 P101	HEADER,10-PIN STRT REF:2112-07-0000	MC000-123	W-I	2112-07-0003	2
P103	HEADER,16-PIN STRT REF:2112-07-0000	MC000-124	W-I	2112-07-0004	1
P203	HEADER,4-PIN STRT REF:2112-07-0000	MC000-097	W-I	2112-07-0015	1
P204	HEADER,9-PIN STRT REF:2112-07-0000	MC000-122	W-I	2112-07-0002	1
L1 L2	CHOKE, 10.0MH,10% LA005-010	08N100K	ASE	1810-03-0100	2
WAVETEK PARTS LIST		TITLE MAIN BD ASSY	ASSEMBLY NO. 1110-00-0890 PAGE: 2		REV B

REFERENCE DESIGNATORS	PART DESCRIPTION	ORIG-MFGR-PART-NO	MFGR	WAVETEK NO.	QTY/PT
L3	CHOKE,10MILH,10% LA004-310	1S5103K	ASE	1810-02-1001	1
Q01 Q03	TRANS QA050-880	2N5088	MOT	4901-05-0880	2
Q02 Q05	TRANS QA054-610	2N5461	MOT	4901-05-4610	2
Q04	TRANS QB000-010	T0101	SPR	4902-00-1010	1
Q06 Q07 Q09	TRANS QB000-009	MPS3702	MOT	4902-03-7020	3
Q08	TRANS QA038-541	2N3854A	G-E	4901-03-8541	1
Q10	TRANS-QA042-500	2N4250	FCD	4901-04-2500	1
Q11	TRANS QA054-580	2N5458	MOT	4901-05-4580	1
R01 R10	RES,MF,1/8W,1%,8.06K RF212-806	MF55K-8.06K	ASE	4701-03-8061	2
R02 R11	RES,MF,1/8W,1%,10K RF213-100	MF55K10K	ASE	4701-03-1002	2
R03 R12 R32 R55 R98	RES,C,1/4W,5%,4.7K RC103-247	CF1/4-4.7K	ASE	4700-15-4701	5
R04 R13 R42 R43	RES,C,1/4W,5%,680 RC103-168	CF1/4-680	ASE	4700-15-6800	4
R05 R14	RES,C,1/4W,5%,330 RC103-133	CF1/4-330	ASE	4700-15-3300	2
R06	RES,MF,1/8W,1%,2.49K RF212-249	MF55K-2.49K	ASE	4701-03-2491	1
WAVETEK PARTS LIST		TITLE MAIN BD ASSY	ASSEMBLY NO. 1110-00-0890 PAGE: 3		REV B

REFERENCE DESIGNATORS	PART DESCRIPTION	ORIG-MFGR-PART-NO	MFGR	WAVETEK NO.	QTY/PT
R07	RES,MF,1/8W,1%,5.11K RF212-511	MF55K-5.11K	ASE	4701-03-5111	1
R08	POT,2K,RP131-220	360T202B	CTS	4610-00-3202	1
R09	RES,MF,1/8W,1%,13.0K RF213-130	MF55K-13.0K	ASE	4701-03-1302	1
R15 R16	RES,SET,2-10K,1/8W QTY:2:4701-03-1002	RX000-003	W-I	4789-00-0004	1
R18	RES,C,1/4W,5%,3.9M RC103-539	CB3955	A-B	4700-15-3904	1
R20 R39	RES,C,1/4W,5%,3.3K RC103-233	CF1/4-3.3K	ASE	4700-15-3301	2
R21 R27	RES,C,1/4W,5%,5.6K RC103-256	CF1/4-5.6K	ASE	4700-15-5601	2
R23 R28	RES,C,1/4W,5%,22K RC103-322	CF1/422K	ASE	4700-15-2202	2
R24 R29	RES,C,1/4W,5%,270 RC103-127	CF1/4-270	ASE	4700-15-2700	2
R25	RES,C,1/4W,5%,1.5M RC103-515	CF1/4-1.5M	ASE	4700-15-1504	1
R30 R31 R34 R38 R41 R44 R47 R54 R73 R74 R76 R83 R87 R93 R95 R96 R80	RES,C,1/4W,5%,10K RC103-310	CF1/4-10K	ASE	4700-15-1002	17
WAVETEK PARTS LIST		TITLE MAIN BD ASSY	ASSEMBLY NO. 1110-00-0890 PAGE: 4		REV B

REFERENCE DESIGNATORS	PART DESCRIPTION	ORIG-MFGR-PART-NO	MFGR	WAVETEK NO.	QTY/PT
R33	RES,C,1/4W,5%,47K RC103-347	CF1/4-47K	ASE	4700-15-4702	1
R35	RES,C,1/4W,5%,1.8M RC103-518	CF1/4-1.8M	ASE	4700-15-1804	1
R36 R91	RES,C,1/4W,5%,2.2M RC103-522	CF1/4-2.2M	ASE	4700-15-2204	2
R37 R90	RES,C,1/4W,5%,1M RC103-510	CF1/4-1M	ASE	4700-15-1004	2
R40	RES,C,1/4W,5%,2.2K RC103-222	CF1/4-2.2K	ASE	4700-15-2201	1
R45 R46	RES,C,1/4W,5%,24K RC103-324	CF1/4-24K	ASE	4700-15-2402	2
R48 R49 R50 R51	RES,MF,1/8W,1%,178K RF214-178	MF55K-178K	ASE	4701-03-1783	4
R52	RES,C,1/4W,5%,15M RC103-615	CB1565	A-B	4700-15-1505	1
R53 R84	RES,C,1/4W,5%,470K RC103-447	CF1/4-470K	ASE	4700-15-4703	2
R56 R71 R82 R85	POT,20K,RP131-320	360T203B	CTS	4610-00-3203	4
R57 R78	RES,C,1/4W,5%,2.7K RC103-227	CF1/4-2.7K	ASE	4700-15-2701	2
R58 R59 R60 R92 R94	RES,C,1/4W,5%,1K RC103-210	CF1/4-1K	ASE	4700-15-1001	5
WAVETEK PARTS LIST		TITLE MAIN BD ASSY	ASSEMBLY NO. 1110-00-0890 PAGE: 5		REV B

REFERENCE DESIGNATORS	PART DESCRIPTION	ORIG-MFGR-PART-NO	MFGR	WAVETEK NO.	QTY/PT
R61 R62 R63 R64	POT,CONT,100K RP131-410	360T104B	CTS	4610-00-3104	4
R65	RES,C,1/4W,5%,120K RC103-412	CF1/4-120K	ASE	4700-15-1203	1
R66 R67	RES,C,1/4W,5%,220K RC103-422	CF1/4220K	ASE	4700-15-2203	2
R68 R86	RES,C,1/4W,5%,330K RC103-433	CF1/4-330K	ASE	4700-15-3303	2
R69	RES,C,1/4W,5%,100K RC103-410	CF1/4-100K	ASE	4700-15-1003	1
R70	RES,C,1/4W,5%,75K RC103-375	CF1/4-75K	ASE	4700-15-7502	1
R72	RES,MF,1/8W,1%,36.5K RF213-365	MF55K-36.5K	ASE	4701-03-3652	1
R75	RES,C,1/4W,5%,33K RC103-333	CF1/4-33K	ASE	4700-15-3302	1
R77	RES,C,1/4W,5%,20K RC103-320	CF1/4-20K	ASE	4700-15-2002	1
R79	POT,10K,RP131-310	360T103B	CTS	4610-00-3103	1
R81	RES,C,1/4W,5%,100 RC103-110	CF1/4-100	ASE	4700-15-1000	1
R89	RES,C,1/4W,5%,680K RC103-468	CF1/4-680K	ASE	4700-15-6803	1
WAVETEK PARTS LIST		TITLE MAIN BD ASSY	ASSEMBLY NO. 1110-00-0890 PAGE: 6		REV B

REFERENCE DESIGNATORS	PART DESCRIPTION	ORIG-MFGR-PART-NO	MFGR	WAVETEK NO.	QTY/PT
R97	RES,C,1/2W,5%,1.2K RC105-212	CF1/2-1.2K	ASE	4700-25-1201	1
WAVETEK PARTS LIST		TITLE MAIN BD ASSY	ASSEMBLY NO. 1110-00-0890 PAGE: 7		REV B

REFERENCE DESIGNATORS	PART DESCRIPTION	ORIG-MFGR-PART-NO	MFGR	WAVETEK NO.	QTY/PT
C1	CAP,MYLAR,.15MF,100V CP103-415	WMF1P15	C-D	1510-60-2154	1
C2 C3	CAP,CER,.02UF,50V	TG-820	SPR	1510-10-2203	2
C4	CAP,CER,470PF,1KV CD102-147	60U471M	MDC	1510-10-1471	1
C5	CAP,CER,.001MFD,1KV CD102-210	5GAD10	SPR	1510-10-1102	1
CR1 CR2 CR3 CR4 CR5	DIODE DG109-140	1N4148	FCD	4807-01-0914	5
IC1	OP AMPL T0-5 IL003-004	LF355H	NAT	7000-03-5501	1
IC2	IC,IC000-005	RC4558DN	RAY	7000-14-5800	1
J101	CONN,PV CARD MC000-119	65001-006	BER	2112-10-0001	1
P102	HEADER,7-PIN STRT REF:2112-07-0000	MC000-125	W-I	2112-07-0005	1
Q1 Q3 Q6	TRANS QA054-580	2N5458	MOT	4901-05-4580	3
Q2 Q8	TRANS QB000-009	MPS3702	MOT	4902-03-7020	2
Q4 Q5 Q7	TRANS QA038-541	2N3854A	G-E	4901-03-8541	3
Q9	TRANS QA054-610	2N5461	MOT	4901-05-4610	1
R01 R02 R05 R23	RES,C,1/4W,5%,10K RC103-310	CF1/4-10K	ASE	4700-15-1002	4
WAVETEK PARTS LIST		TITLE RATE CARD,C001	ASSEMBLY NO. 1110-00-0900 PAGE: 1		REV C

REFERENCE DESIGNATORS	PART DESCRIPTION	ORIG-MFGR-PART-NO	MFGR	WAVETEK NO.	QTY/PT
R03 R22	RES,C,1/4W,5%,4.7K RC103-247	CF1/4-4.7K	ASE	4700-15-4701	2
R04 R07 R13 R26	RES,C,1/4W,5%,10M RC103-610	CB1065	A-B	4700-15-1005	4
R06 R09 R10 R16 R20 R21	RES,C,1/4W,5%,100K RC103-410	CF1/4-100K	ASE	4700-15-1003	6
R08	RES,MF,1/8W,1%,36.5K RF213-365	MF55K-36.5K	ASE	4701-03-3652	1
R11 R12	RES,C,1/4W,5%,22K RC103-322	CF1/422K	ASE	4700-15-2202	2
R14	RES,C,1/4W,5%,47K RC103-347	CF1/4-47K	ASE	4700-15-4702	1
R15 R29	RES,C,1/4W,5%,27K RC103-327	CF1/4-27K	ASE	4700-15-2702	2
R17	RES,C,1/4W,5%,20K RC103-320	CF1/4-20K	ASE	4700-15-2002	1
R18	POT,50K,RP129-350	360S03B	CTS	4610-00-1503	1
R19	RES,C,1/4W,5%,68K RC103-368	CF1/4-68K	ASE	4700-15-6802	1
R24	RES,MF,1/8W,1%,13.0K RF213-130	MF55K-13.0K	ASE	4701-03-1302	1
R25	RES,C,1/4W,5%,2.2M RC103-522	CF1/4-2.2M	ASE	4700-15-2204	1
WAVETEK PARTS LIST		TITLE RATE CARD,C001	ASSEMBLY NO. 1110-00-0900		REV C
PAGE: 2					

REFERENCE DESIGNATORS	PART DESCRIPTION	ORIG-MFGR-PART-NO	MFGR	WAVETEK NO.	QTY/PT
R27	RES,MF,1/8W,1%,44.2K RF213-442	MF55K-44.2K	ASE	4701-03-4422	1
R28	RES,C,1/4W,5%,180K RC103-418	CF1/4-180K	ASE	4700-15-1803	1
R30 R34	RES,C,1/4W,5%,1K RC103-210	CF1/4-1K	ASE	4700-15-1001	2
R31	POT,20K,RP129-320	360S203B	CTS	4610-00-1203	1
R32	RES,C,1/4W,5%,12K RC103-312	CF1/4-12K	ASE	4700-15-1202	1
R33	RES,C,1/4W,5%,75 RC103-075	CR1/4-75	ASE	4700-15-7509	1
WAVETEK PARTS LIST		TITLE RATE CARD,C001	ASSEMBLY NO. 1110-00-0900		REV C
PAGE: 3					

REFERENCE DESIGNATORS	PART DESCRIPTION	ORIG-MFGR-PART-NO	MFGR	WAVETEK NO.	QTY/PT
C1 C3	CAP,TANT,10MF,25V CE120-010	162D106X0025D02	SPR	1510-21-7100	2
C2	CAP,MYLAR,.15MF,100V CP103-415	WMF1P15	C-D	1510-60-2154	1
CR1 CR2 CR3	DIODE DG109-140	1N4148	FCD	4807-01-0914	3
IC1	IC,IC000-005	RC45580N	RAY	7000-14-5800	1
J101	CONN,PV CARD MC000-119	65001-006	BER	2112-10-0001	1
Q1	TRANS QA036-541	2N3854A	G-E	4901-03-8541	1
R01 R11 R12	RES,C,1/4W,5%,10K RC103-310	CF1/4-10K	ASE	4700-15-1002	3
R02	RES,C,1/4W,5%,20K RC103-320	CF1/4-20K	ASE	4700-15-2002	1
R03	RES,C,1/4W,5%,100K RC103-410	CF1/4-100K	ASE	4700-15-1003	1
R04 R09	RES,C,1/4W,5%,27K RC103-327	CF1/4-27K	ASE	4700-15-2702	2
R05 R07	RES,C,1/4W,5%,47K RC103-347	CF1/4-47K	ASE	4700-15-4702	2
R06	POT,20K,RP129-320	360S203B	CTS	4610-00-1203	1
R08	RES,C,1/4W,5%,220K RC103-422	CF1/4220K	ASE	4700-15-2203	1
WAVETEK PARTS LIST		TITLE RATE CARD,C004	ASSEMBLY NO. 1110-00-0970 PAGE: 1		REV

REFERENCE DESIGNATORS	PART DESCRIPTION	ORIG-MFGR-PART-NO	MFGR	WAVETEK NO.	QTY/PT
R10	RES,C,1/4W,5%,47 RC103-047	CF1/4-47	ASE	4700-15-4709	1
WAVETEK PARTS LIST		TITLE RATE CARD,C004	ASSEMBLY NO. 1110-00-0970 PAGE: 2		REV

REFERENCE DESIGNATORS	PART DESCRIPTION	ORIG-MFGR-PART-NO	MFGR	WAVETEK NO.	QTY/PT
C01 C05 C07 C09 C13 C14 C16 C18 C20 C35 C39 C42 C49	CAP, FT, 500PF, 20X250V CF104-150	4420-500PF	AER	1510-30-3501	13
C02 C58	CAP, Q.C., .47PF CG101-147	QC-.47PF	Q-C	1510-40-0478	2
C03 C06 C08 C28 C31 C36 C38 C41 C43 C45 C46	CAP, TANT, .47MF, 50V CE113-447	935	TRW	1510-21-9470	11
C04 C32 C59	CAP, M.C., 3.9PF CG102-239	MC-3.9PF	Q-C	1510-40-1399	3
C10 C11 C15 C55	CAP, CER, .01MF, 100V CD103-310	68U103M	MDC	1510-10-2103	4
C12	CAP, CER, 120PF, 1KV CD102-112	60U121M	MDC	1510-10-1121	1
C17 C24 C26 C27 C47 C51 C52	CAP, F.T., 470PF CF101-147	FASC-4712	A-B	1510-30-0471	7
C19	CAP, CER, 100PF, 1KV CD108-110	CN1500	RMC	1510-10-5101	1
C21 C22	CAP, FT, CER, 100PF, 20% CF104-110	4420-100PF	AER	1510-30-3101	2
C23 C29 C57	CAP, TANT, 10MF, 25V CE120-010	162D106X0025002	SPR	1510-21-7100	3
C25	CAP, F.T., 6.8PF CF102-R68	FASC-6892	A-B	1510-30-1689	1
WAVETEK PARTS LIST		TITLE SWEEP OSC MODULE M9Y-1	ASSEMBLY NO. 1114-00-0070 PAGE: 1		REV H

REFERENCE DESIGNATORS	PART DESCRIPTION	ORIG-MFGR-PART-NO	MFGR	WAVETEK NO.	QTY/PT
C30	CAP, M-C, 4.7PF, 10% CG102-247	QC-4.7PF	Q-C	1510-40-1479	1
C33	CAP, CER, .025MF, 50V CD103-325	TG-S25	SPR	1510-10-2253	1
C37	CAP, CER, 10PF, 1KV CD101-010	10TCC-010	SPR	1510-10-0100	1
C40 C50 C56	CAP, ELECT, 1MF, 25V CE120-001	162D105X90250C2	SPR	1510-21-7010	3
C44	CAP, CER, 15PF, 1KV CD101-015	10TCC-015	SPR	1510-10-0150	1
C48 C53	CAP, CER, .001MFD, 1KV CD102-210	5GA010	SPR	1510-10-1102	2
C54	CAP, CER, 6.8PF, 1KV CD101-R68	60C0H6R8D	MDC	1510-10-0689	1
CR01 CR02 CR03 CR04	DIODE DG100-822	1N82A-K102	KEM	4807-03-0001	4
CR05 CR07	DIODE DB000-001	HW6.8B	C-L	4801-02-0001	2
CR06 CR12 CR13	DIODE DP000-050	5082-3080	H-P	4805-02-0002	3
CR08 CR14	DIODE DG100-821	1N82AG	G-I	4807-01-0082	2
CR09 CR10 CR11	DIODE DC000-005	8B141A	ITT	4889-00-0001	3
CR15	DIODE DR000-001	1N4004	P-C	4806-01-4004	1
IC1	IC, IC000-004	N5741T	SIG	7000-57-4101	1
WAVETEK PARTS LIST		TITLE SWEEP OSC MODULE M9Y-1	ASSEMBLY NO. 1114-00-0070 PAGE: 2		REV H

REFERENCE DESIGNATORS	PART DESCRIPTION	ORIG-MFGR-PART-NO	MFGR	WAVETEK NO.	QTY/PT
J1 J2 J3 J4	CONN JF000-005	37JR116-1	S-C	2110-03-0002	4
L01 L02 L03 L04 L08 L11 L16 L18 L21	RF CHOKE	CHOKE	W-I	1819-99-9999	9
L05 L07	FERRITE CHOKE LA009-004	T1255-1	HYT	1810-05-0001	2
L06 L12 L14 L15 L17 L19 L20 L23 L24	FERRITE CHOKE LA009-010	T1255-2	HYT	1810-05-0002	9
L09 L10 L13	CHOKE .22MH 10% LA005-R02	08NR22K	ASE	1810-03-0228	3
L22 L25	CHOKE,4.7MH,10% LA005-R47	08N4R7K	ASE	1810-03-0479	2
Q01 Q07 Q08 Q09 Q11	TRANS QA051-790	2N5179	RCA	4901-05-1790	5
Q02 Q03 Q06 Q16	TRANS QA050-530	2N5053	APX	4901-05-0530	4
Q04	TRANS QA038-541	2N3854A	G-E	4901-03-8541	1
Q05	TRANS QB000-009	MPS3702	MDT	4902-03-7020	1
Q10 Q15	TRANS QA054-580	2N5458	MDT	4901-05-4580	2
Q12 Q13	TRANS QB000-018	SD1006	SSS	4902-01-0060	2
Q14	TRANS QB000-019	SD1005	SSS	4902-01-0050	1
R01 R40 R49 R55 R74	RES,C,1/4W,5%,680 RC103-168	CF1/4-680	ASE	4700-15-6800	5
WAVETEK PARTS LIST		TITLE SWEEP OSC MODULE M9Y-1	ASSEMBLY NO. 1114-00-0070 PAGE: 3		REV H

REFERENCE DESIGNATORS	PART DESCRIPTION	ORIG-MFGR-PART-NO	MFGR	WAVETEK NO.	QTY/PT
R02 R03 R15 R34 R41 R42 R70	RES,C,1/4W,5%,4.7K RC103-247	CF1/4-4.7K	ASE	4700-15-4701	7
R04 R19 R35 R36 R38	RES,C,1/4W,5%,47 RC103-047	CF1/4-47	ASE	4700-15-4709	5
R05 R07	RES,C,1/4W,5%,120 RC103-112	CF1/4-120	ASE	4700-15-1200	2
R06	POT,1K,RP129-210	360S102B	CTS	4610-00-1102	1
R08 R18 R75	RES,C,1/4W,5%,33 RC103-033	CF1/4-33	ASE	4700-15-3309	3
R09 R16 R20 R22 R28 R33 R47 R64	RES,C,1/4W,5%,100 RC103-110	CF1/4-100	ASE	4700-15-1000	8
R10*	RES,C,1/4W,5%,390 RC103-139	CF1/4-390	ASE	4700-15-3900	1
R11 R23 R45 R48 R59	RES,C,1/4W,5%,470 RC103-147	CF1/4-470	ASE	4700-15-4700	5
R12 R27 R29 R67 R72	RES,C,1/4W,5%,10K RC103-310	CF1/4-10K	ASE	4700-15-1002	5
R13 R73	RES,C,1/4W,5%,1.5K RC103-215	CF1/4-1.5K	ASE	4700-15-1501	2
R14	RES,C,1/4W,5%,27K RC103-327	CF1/4-27K	ASE	4700-15-2702	1
R17*	RES,C,1/4W,5%,75 RC103-075	CR1/4-75	ASE	4700-15-7509	1
WAVETEK PARTS LIST		TITLE SWEEP OSC MODULE M9Y-1	ASSEMBLY NO. 1114-00-0070 PAGE: 4		REV H

REFERENCE DESIGNATORS	PART DESCRIPTION	ORIG-MFGR-PART-NO	MFGR	WAVETEK NO.	QTY/PT
R21 R46	RES,C,1/4W,5%,2.2K RC103-222	CF1/4-2.2K	ASE	4700-15-2201	2
R24	RES,C,1/4W,5%,330 RC103-133	CF1/4-330	ASE	4700-15-3300	1
R25	RES,C,1/4W,5%,1M RC103-510	CF1/4-1M	ASE	4700-15-1004	1
R26 R63	RES,C,1/4W,5%,1K RC103-210	CF1/4-1K	ASE	4700-15-1001	2
R30	POT,20K,RP144-320	91AR20K	BEK	4610-00-4203	1
R31	RES,C,1/4W,5%,470K RC103-447	CF1/4-470K	ASE	4700-15-4703	1
R32	RES,C,1/4W,5%,2.2M RC103-522	CF1/4-2.2M	ASE	4700-15-2204	1
R39	RES,C,1/4W,5%,10 RC103-010	CF1/4-10	ASE	4700-15-1009	1
R43	RES,C,1/4W,10%,10M RC104-610	CB1061	A-B	4700-16-1005	1
R44	RES,C,1/4W,5%,15M RC103-615	CB1565	A-B	4700-15-1505	1
R50 R52 R56 R60	RES,C,1/4W,5%,1.8K RC103-216	CF1/4-1.8K	ASE	4700-15-1801	4
R51	RES,C,1/4W,5%,180 RC103-118	CF1/4-180	ASE	4700-15-1800	1
WAVETEK PARTS LIST		TITLE SWEEP OSC MODULE M9Y-1	ASSEMBLY NO. 1114-00-0070 PAGE: 5		REV H

REFERENCE DESIGNATORS	PART DESCRIPTION	ORIG-MFGR-PART-NO	MFGR	WAVETEK NO.	QTY/PT
R53	RES,C,1/2W,5%,150 RC105-115	CF1/2-150	ASE	4700-25-1500	1
R54 R5A	RES,C,1/4W,5%,4.7 RC103-R47	CF1/4-4.7	ASE	4700-15-4708	2
R61	RES,C,1/2W,5%,68 RC105-068	CF1/2-68	ASE	4700-25-6809	1
R65	RES,C,1/4W,5%,82 RC103-082	CF1/4-82	ASE	4700-15-8209	1
R66	RES,L-A,1/4W,1%,49.9 RF404-990	SPS-N-347-49.9	IRC	4741-49-9007	1
R71	RES,C,1/4W,5%,7.5K RC103-275	CF1/4-7.5K	ASE	4700-15-7501	1
R62*	RES,C,1/4W,5%,22	CF1/4-22	ASE	4700-15-2209	1
PARTS SUBSTITUTED FOR M9YA-1					
J3	CONN JF000-004	27-21	APL	2110-03-0001	1
R66	RES,L-A,1/4W,1%,75.0 RF407-500	SPS-N-347-75	IRC	4741-75-0007	1
WAVETEK PARTS LIST		TITLE SWEEP OSC MODULE M9Y-1	ASSEMBLY NO. 1114-00-0070 PAGE: 6		REV H

REFERENCE DESIGNATORS	PART DESCRIPTION	ORIG-MFGR-PART-NO	MFGR	WAVETEK NO.	QTY
C01 C20 C21	CAP, CER, F. T. 1000PF CF112-210	54-794-010-102P	SPEC	1510-30-8102	3
C02	CAP, FT, 500PF, 20%250V CF104-150	4420-500PF	AER	1510-30-3501	1
C03 C04 C05 C06 C07	CAP, VAR, 3.5-13PF250V CV101-013	7S-TRIKO-02-3.5-13PF	STR	1510-70-0130	5
C08 C09 C10 C11 C12	CAP, CER, .001MFD, 1KV CD102-210	5GAD10	SPR	1510-10-1102	5
C13	CAP, F. T., 6.8PF CF102-R6B	FA5C-6B92	A-B	1510-30-1689	1
C14 C15 C16 C17 C18	CAP, CER, 200PF, 1KV CD102-120	5GA-T20	SPR	1510-10-1201	5
C19 C22	CAP, CER, .05MF, 100V CD103-350	TG-S50	SPR	1510-10-2503	2
C23	CAP, CER, 120PF, 1KV CD102-112	60U121M	MDC	1510-10-1121	1
CR01 CR02 CR03 CR04 CR05	DIODE D9000-009	5082-2835	H-P	4809-02-0002	5
CR06 CR07 CR08 CR09 CR10 CR11 CR12 CR13	DIODE DG109-140	1N4148	FCD	4807-01-0914	8
CR14	DIODE DR000-001	1N4004	P-C	4806-01-4004	1
IC01 IC02 IC03	IC, IC000-005	RC455BDN	RAY	7000-14-5800	3
WAVETEK PARTS LIST		TITLE RF MKR, M13J	ASSEMBLY NO. 1114-00-0151 PAGE: 1		REV C

REFERENCE DESIGNATORS	PART DESCRIPTION	ORIG-MFGR-PART-NO	MFGR	WAVETEK NO.	QTY
J01 J02 J03	CONN JF000-005	37JR116-1	S-C	2110-03-0002	3
Q01 Q09	TRANS QA050-530	2N5053	APX	4901-05-0530	2
Q02 Q03 Q04 Q05 Q06	TRANS QB000-009	MPS3702	MDT	4902-03-7020	5
Q07	TRANS QA039-040	2N3904	T-I	4901-03-9040	1
Q08	TRANS QA038-541	2N3854A	G-E	4901-03-8541	1
R01	POT, 1K RF124-210	WA260325-102MA	A-B	4610-10-7102	1
R02	RES, C, 1/4W, 5%, 47K RC103-347	CF1/4-47K	ASE	4700-15-4702	1
R03 R05 R06 R07 R08 R09	RES, C, 1/4W, 5%, 1K RC103-210	CF1/4-1K	ASE	4700-15-1001	6
R04	RES, C, 1/4W, 5%, 56 RC103-056	CF1/4-56	ASE	4700-15-5609	1
R10 R11 R12 R13 R14	RES, C, 1/4W, 5%, 270 RC103-127	CF1/4-270	ASE	4700-15-2700	5
R15 R33 R34	RES, C, 1/4W, 5%, 10K RC103-310	CF1/4-10K	ASE	4700-15-1002	3
R16	RES, C, 1/4W, 5%, 1.5M RC103-515	CF1/4-1.5M	ASE	4700-15-1504	1
R17 R18 R19 R20 R21	RES, C, 1/4W, 5%, 360K RC103-436	CF1/4-360K	ASE	4700-15-3603	5
WAVETEK PARTS LIST		TITLE RF MKR, M13J	ASSEMBLY NO. 1114-00-0151 PAGE: 2		REV C

REFERENCE DESIGNATORS	PART DESCRIPTION	ORIG-MFGR-PART-NO	MFGR	WAVETEK NO.	QTY
R22 R23 R24 R25 R26	RES, C, 1/4W, 5%, 51K RC103-351	CF1/4-51K	ASE	4700-15-5102	5
R27	RES, C, 1/4W, 5%, 24K RC103-324	CF1/4-24K	ASE	4700-15-2402	1
R28 R29 R30 R31 R32 R36	RES, C, 1/4W, 5%, 22K RC103-322	CF1/422K	ASE	4700-15-2202	6
R35	RES, C, 1/4W, 5%, 56K RC103-356	CF1/4-56K	ASE	4700-15-5602	1
R37	RES, C, 1/4W, 5%, 1M RC103-510	CF1/4-1M	ASE	4700-15-1004	1
R38 R39 R40 R41 R42	RES, C, 1/4W, 5%, 5.6K RC103-256	CF1/4-5.6K	ASE	4700-15-5601	5
R43	RES, C, 1/4W, 5%, 3.3K RC103-233	CF1/4-3.3K	ASE	4700-15-3301	1
R44	RES, C, 1/4W, 5%, 2.7K RC103-227	CF1/4-2.7K	ASE	4700-15-2701	1
R45	RES, C, 1/4W, 5%, 820 RC103-182	CF1/4-820	ASE	4700-15-8200	1
R46	RES, C, 1/4W, 5%, 10 RC103-010	CF1/4-10	ASE	4700-15-1009	1
T01	RF XFMR FROM: 1813-00-0007	1210-40-0017	W-I	1210-40-0017	1
WAVETEK PARTS LIST		TITLE RF MKR, M13J	ASSEMBLY NO. 1114-00-0151 PAGE: 3		REV C

REFERENCE DESIGNATORS	PART DESCRIPTION	ORIG-MFGR-PART-NO	MFGR	WAVETEK NO.	QTY/PT
IC01	IC, IC000-005	RC4558DN	RAY	7000-14-5800	1
R01 R03 R06 R08	RES, C, 1/4W, 5%, 10K RC103-310	CF1/4-10K	ASE	4700-15-1002	4
R02	POT, 20K, RP129-320	36082038	CTS	4610-00-1203	1
R04	RES, C, 1/4W, 5%, 6.8K RC103-268	CF1/4-6.8K	ASE	4700-15-6801	1
R07	POT, 20K RP154-320	WAIN032S203MA	A-B	4610-11-9203	1
R09	RES, C, 1/4W, 5%, 4.7K RC103-247	CF1/4-4.7K	ASE	4700-15-4701	1
S01	SWITCH, TOGGLE ST005-006	7101P3Y1ZQEN	C-K	5106-00-0014	1
WAVETEK PARTS LIST		TITLE TILT ASSY	ASSEMBLY NO. 1110-00-1050 PAGE: 1		REV

REFERENCE DESIGNATORS	PART DESCRIPTION	ORIG-MFGR-PART-NO	MFGR	WAVETEK NO.	QTY/PT
C1 C2	CAP,CER,.005MF,1KV CD103-250	TG-050	SPR	1510-10-2502	2
C3 C4	CAP,TANT,10MF,25V CE120-010	162D106X00250D2	SPR	1510-21-7100	2
CR1 CR2	DIODE DG109-140	1N4148	FCD	4807-01-0914	2
IC1	IC,IC000-005	RC4558DN	RAY	7000-14-5800	1
IC2	IC,IL004-001	LM339N	NAT	7000-03-3900	1
L1 L2	CHOKE, 10.0MH,10% LA005-010	08N100K	ASE	1810-03-0100	2
R01 R03 R15 R16 R17 R18 R20 R23	RES,C,1/4W,5%,10K RC103-310	CF1/4-10K	ASE	4700-15-1002	8
R02	POT,20K,RP129-320	360S2038	CTS	4610-00-1203	1
R04 R12	POT,20K RP156-320	43P203T601	SPE	4610-00-5203	2
R05 R06 R10 R11 R22	RES,C,1/4W,5%,4.7K RC103-247	CF1/4-4.7K	ASE	4700-15-4701	5
R07	RES,C,1/4W,5%,100K RC103-410	CF1/4-100K	ASE	4700-15-1003	1
R08	POT,2K,RP129-220	360S202B	CTS	4610-00-1202	1
R09	RES,C,1/4W,5%,330 RC103-133	CF1/4-330	ASE	4700-15-3300	1
WAVETEK PARTS LIST		TITLE NOTCH/TILT ASSY	ASSEMBLY NO. 1110-00-1060		REV

PAGE: 1

REFERENCE DESIGNATORS	PART DESCRIPTION	ORIG-MFGR-PART-NO	MFGR	WAVETEK NO.	QTY/PT
R13	RES,C,1/4W,5%,9.1K RC103-291	CF1/4-9.1K	ASE	4700-15-9101	1
R14 R19	RES,C,1/4W,5%,6.8K RC103-268	CF1/4-6.8K	ASE	4700-15-6801	2
R21	POT,20K RP154-320	WAIN032S203MA	A-B	4610-11-9203	1
R24	RES,C,1/4W,5%,3.3K RC103-233	CF1/4-3.3K	ASE	4700-15-3301	1
S1	SWITCH,TOGGLE ST003-006	7201PN-BLK	C-K	5106-00-0012	1
2	HARNESS ASSY	WY1060-B2	W-I	1219-00-0104	1
WAVETEK PARTS LIST		TITLE NOTCH/TILT ASSY	ASSEMBLY NO. 1110-00-1060		REV

PAGE: 2

REFERENCE DESIGNATORS	PART DESCRIPTION	ORIG-MFGR-PART-NO	MFGR	WAVETEK NO.	QTY/PT
C01	CAP, VALUE DETERMINED IN CALIBRATION	CAP, TRIM	W-I	1519-99-9999	1
C02	CAP, CER, 33PF, 1KV CD104-033	10TU-Q33	SPR	1510-10-3330	1
C03 C14	CAP, CER, .01MF, 100V CD103-310	68U103M	MDC	1510-10-2103	2
C04	CAP, CER, .025MF, 50V CD103-325	TG-S25	SPR	1510-10-2253	1
C05	CAP, CER, 68PF, 1KV CD104-068	68U2J680J	MDC	1510-10-3680	1
C06	CAP, CER, 100PF, 1KV CD104-110	10TCU-T10	SPR	1510-10-3101	1
C07	CAP, VAR, 3.5-13PF, 250V CV101-013	7S-TR1K0-02-3.5-13PF	STR	1510-70-0130	1
C08	CAP, CER, 15PF, 1KV CD101-015	10TCC-015	SPR	1510-10-0150	1
C09	CAP, CER, 47PF, 1KV CD104-047	60U2J470J	MDC	1510-10-3470	1
C10 C13	CAP, CER, .001MFD, 1KV CD102-210	5GAD10	SPR	1510-10-1102	2
C11	CAP, TANT, .47MF, 50V CE113-447	935	TRW	1510-21-9470	1
C12	CAP, CER, 470PF, 1KV CD102-147	60U471M	MDC	1510-10-1471	1
WAVETEK PARTS LIST		TITLE 1 MHZ HARMONIC MARKER, M6H-1	ASSEMBLY NO. 1114-00-0050 PAGE: 1		REV E

REFERENCE DESIGNATORS	PART DESCRIPTION	ORIG-MFGR-PART-NO	MFGR	WAVETEK NO.	QTY/PT
C15	CAP, FT, 500PF, 20% 250V CF104-150	4420-500PF	AER	1510-30-3501	1
C16	CAP, F.T., 6.8PF CF102-R68	FA5C-6892	A-B	1510-30-1689	1
C17	CAP, F.T., 470PF CF101-147	FA5C-4712	A-B	1510-30-0471	1
C18	CAP, TANT, 10MF, 25V CE120-010	1620106X0025DD2	SPR	1510-21-7100	1
CR1 CR2	DIODE DG100-821	1N82AG	G-I	4807-01-0082	2
J1 J2	CONN JF000-005	37JR116-1	S-C	2110-03-0002	2
L1 L2 L3	RF CHOKE	CHOKE	W-I	1819-99-9999	3
L4	FERRITE CHOKE LA009-004	T1255-1	HYT	1810-05-0001	1
Q1 Q3	TRANS QB000-009	MPS3702	MOT	4902-03-7020	2
Q2	TRANS QA038-541	2N3854A	G-E	4901-03-8541	1
Q4	TRANS QA051-790	2N5179	RCA	4901-05-1790	1
Q5	TRANS QB000-013	A430	APX	4902-00-4300	1
Q6	TRANS QA054-580	2N5458	MOT	4901-05-4580	1
Q7	TRANS QA050-880	2N5088	MOT	4901-05-0880	1
R01 R16	RES, C, 1/4W, 5%, 1K RC103-210	CF1/4-1K	ASE	4700-15-1001	2
WAVETEK PARTS LIST		TITLE 1 MHZ HARMONIC MARKER, M6H-1	ASSEMBLY NO. 1114-00-0050 PAGE: 2		REV E

REFERENCE DESIGNATORS	PART DESCRIPTION	ORIG-MFGR-PART-NO	MFGR	WAVETEK NO.	QTY/PT
R02 R05 R12	RES,C,1/4W,5%,3.9K RC103-239	CF1/43.9K	ASE	4700-15-3901	3
R03 R04	RES,C,1/4W,5%,2.2K RC103-222	CF1/4-2.2K	ASE	4700-15-2201	2
R06	RES,C,1/4W,5%,27K RC103-327	CF1/4-27K	ASE	4700-15-2702	1
R07 R09 R13	RES,C,1/4W,5%,470 RC103-147	CF1/4-470	ASE	4700-15-4700	3
R08 R20	RES,C,1/4W,5%,10K RC103-310	CF1/4-10K	ASE	4700-15-1002	2
R10 R24	RES,C,1/4W,5%,100 RC103-110	CF1/4-100	ASE	4700-15-1000	2
R11	RES,C,1/4W,5%,75 RC103-075	CR1/4-75	ASE	4700-15-7509	1
R14	RES,C,1/4W,5%,33K RC103-333	CF1/4-33K	ASE	4700-15-3302	1
R15	RES,C,1/4W,5%,1M RC103-510	CF1/4-1M	ASE	4700-15-1004	1
R17	RES,C,1/4W,5%,8.2K RC103-282	CF1/4-8.2K	ASE	4700-15-8201	1
R18	RES,C,1/4W,5%,15K RC103-315	CF1/4-15K	ASE	4700-15-1502	1
R19	RES,C,1/4W,5%,1.5M RC103-515	CF1/4-1.5M	ASE	4700-15-1504	1
WAVETEK PARTS LIST		TITLE 1 MHZ HARMONIC MARKER, M6H-1	ASSEMBLY NO. 1114-00-0050 PAGE: 3		REV E

REFERENCE DESIGNATORS	PART DESCRIPTION	ORIG-MFGR-PART-NO	MFGR	WAVETEK NO.	QTY/PT
R21	POT,20K RP124-320	WA2G032S-203MA	A-B	4610-10-7203	1
R22 R23	RES,C,1/4W,5%,4.7K RC103-247	CF1/4-4.7K	ASE	4700-15-4701	2
X1	CRYSTAL X25W XX000-251	X25W-00.00000	W-I	2310-00-0251	1
WAVETEK PARTS LIST		TITLE 1 MHZ HARMONIC MARKER, M6H-1	ASSEMBLY NO. 1114-00-0050 PAGE: 4		REV E

REFERENCE DESIGNATORS	PART DESCRIPTION	ORIG-MFGR-PART-NO	MFGR	WAVETEK NO.	QTY/PT
C01 C07	CAP,CER,47PF,1KV CD104-047	60U2J470J	MDC	1510-10-3470	2
C02	CAP,CER,330PF,1KV CD104-133	10TCU-T33	SPR	1510-10-3331	1
C03	CAP,CER,120PF,1KV CD104-112	10TCU-T12	SPR	1510-10-3121	1
C04	CAP,FT,500PF,20%250V CF104-150	4420-500PF	AER	1510-30-3501	1
C05	CAP,VAR,3.5-13PF250V CV101-013	7S-TRIKO-02-3.5-13PF	STR	1510-70-0130	1
C06	CAP,CER,15PF,1KV CD101-015	10TCC-Q15	SPR	1510-10-0150	1
C08 C09	CAP,CER,.001MFD,1KV CD102-210	5GAD10	SPR	1510-10-1102	2
C10	CAP,CER,.01MF,100V CD103-310	68U103M	MDC	1510-10-2103	1
C11	CAP,F.T.,6.8PF CF102-R68	FA5C-6892	A-B	1510-30-1689	1
C12	CAP,F.T.,470PF CF101-147	FA5C-4712	A-B	1510-30-0471	1
C13	CAP,TANT,10MF,25V CE120-010	162D106X0025002	SPR	1510-21-7100	1
CR1	DIODE DG100-821	1N824G	G-I	4807-01-0082	1
WAVETEK PARTS LIST		TITLE 10 MHZ HARMONIC MARKER, M6H-10	ASSEMBLY NO. 1114-00-0099 PAGE: 1		REV C

REFERENCE DESIGNATORS	PART DESCRIPTION	ORIG-MFGR-PART-NO	MFGR	WAVETEK NO.	QTY/PT
J1 J2	CONN JF000-005	37JR116-1	S-C	2110-03-0002	2
L1 L3	RF CHOKE	CHOKE	W-I	1819-99-9999	2
L2	FERRITE CHOKE LA009-010	T1255-2	HYT	1810-05-0002	1
L4	FERRITE CHOKE LA009-004	T1255-1	HYT	1810-05-0001	1
Q1	TRANS QA038-541	2N3854A	G-E	4901-03-8541	1
Q2	TRANS QB000-013	A430	APX	4902-00-4300	1
Q3	TRANS QA054-580	2N5458	MOT	4901-05-4580	1
Q4	TRANS QA050-880	2N5088	MOT	4901-05-0880	1
R01	RES,C,1/4W,5%,47K RC103-347	CF1/4-47K	ASE	4700-15-4702	1
R02	RES,C,1/4W,5%,56 RC103-056	CF1/4-56	ASE	4700-15-5609	1
R03	RES,C,1/4W,5%,1.5K RC103-215	CF1/4-1.5K	ASE	4700-15-1501	1
R04 R17	RES,C,1/4W,5%,100 RC103-110	CF1/4-100	ASE	4700-15-1000	2
R05	RES,C,1/4W,5%,75 RC103-075	CR1/4-75	ASE	4700-15-7509	1
R06	RES,C,1/4W,5%,3.9K RC103-239	CF1/43.9K	ASE	4700-15-3901	1
WAVETEK PARTS LIST		TITLE 10 MHZ HARMONIC MARKER, M6H-10	ASSEMBLY NO. 1114-00-0099 PAGE: 2		REV C

REFERENCE DESIGNATORS	PART DESCRIPTION	ORIG-MFGR-PART-NO	MFGR	WAVETEK NO.	QTY/PT
R07	RES,C,1/4W,5%,470 RC103-147	CF1/4-470	ASE	4700-15-4700	1
R08	RES,C,1/4W,5%,33K RC103-333	CF1/4-33K	ASE	4700-15-3302	1
R09	RES,C,1/4W,5%,1M RC103-510	CF1/4-1M	ASE	4700-15-1004	1
R10	RES,C,1/4W,5%,1K RC103-210	CF1/4-1K	ASE	4700-15-1001	1
R11	RES,C,1/4W,5%,8.2K RC103-282	CF1/4-8.2K	ASE	4700-15-8201	1
R12	RES,C,1/4W,5%,15K RC103-315	CF1/4-15K	ASE	4700-15-1502	1
R13	RES,C,1/4W,5%,1.5M RC103-515	CF1/4-1.5M	ASE	4700-15-1504	1
R14	RES,C,1/4W,5%,10K RC103-310	CF1/4-10K	ASE	4700-15-1002	1
R15	POT,20K RP124-320	WA260329-203MA	A-B	4610-10-7203	1
R16	RES,C,1/4W,5%,100K RC103-410	CF1/4-100K	ASE	4700-15-1003	1
X1	CRYSTAL,XX000-321	X32W-00.00000	W-I	2310-00-0321	1
WAVETEK PARTS LIST		TITLE 10 MHZ HARMONIC MARKER, M6H-10	ASSEMBLY NO. 1114-00-0099 PAGE: 3		REV C

REFERENCE DESIGNATORS	PART DESCRIPTION	ORIG-MFGR-PART-NO	MFGR	WAVETEK NO.	QTY/PT
C01	CAP,CER,20PF,1KV CD101-020	60C06200J	MDC	1510-10-0200	1
C02	CAP,CER,120PF,1KV CD104-112	10TCU-T12	SPR	1510-10-3121	1
C03 C07	CAP,CER,47PF,1KV CD104-047	60U2J470J	MDC	1510-10-3470	2
C04	CAP,FT,500PF,20%250V CF104-150	4420-500PF	AER	1510-30-3501	1
C05	CAP,VAR,3.5-13PF250V CV101-013	7S-TRIKU-02-3.5-13PF	STR	1510-70-0130	1
C06	CAP,CER,15PF,1KV CD101-015	10TCC-Q15	SPR	1510-10-0150	1
C08 C09	CAP,CER,.001MFD,1KV CD102-210	56A010	SPR	1510-10-1102	2
C10	CAP,CER,.01MF,100V CD103-310	68U103M	MDC	1510-10-2103	1
C11	CAP,F.T.,.6.8PF CF102-R68	FA5C-6892	A-B	1510-30-1689	1
C12	CAP,F.T.,.470PF CF101-147	FA5C-4712	A-B	1510-30-0471	1
C13	CAP,TANT,10MF,25V CE120-010	1620106X0025DD2	SPR	1510-21-7100	1
CR1	DIODE DG100-821	1N82AG	G-I	4807-01-0082	1
WAVETEK PARTS LIST		TITLE 50 MHZ HARMONIC MARKER, M6H-50	ASSEMBLY NO. 1114-00-0100 PAGE: 1		REV C

REFERENCE DESIGNATORS	PART DESCRIPTION	ORIG-MFGR-PART-NO	MFGR	WAVETEK NO.	QTY/PT
J1 J2	CONN JF000-005	37JR116-1	S-C	2110-03-0002	2
L1 L3	RF CHOKE	CHOKE	W-I	1819-99-9999	2
L2	FERRITE CHOKE LA009-010	T1255-2	HYT	1810-05-0002	1
L4	FERRITE CHOKE LA009-004	T1255-1	HYT	1810-05-0001	1
R01	RES,C,1/4W,5%,47K RC103-347	CF1/4-47K	ASE	4700-15-4702	1
R02	RES,C,1/4W,5%,56 RC103-056	CF1/4-56	ASE	4700-15-5609	1
R03	RES,C,1/4W,5%,1.5K RC103-215	CF1/4-1.5K	ASE	4700-15-1501	1
R04 R17	RES,C,1/4W,5%,100 RC103-110	CF1/4-100	ASE	4700-15-1000	2
R05	RES,C,1/4W,5%,75 RC103-075	CR1/4-75	ASE	4700-15-7509	1
R06	RES,C,1/4W,5%,3.9K RC103-239	CF1/4-3.9K	ASE	4700-15-3901	1
R07	RES,C,1/4W,5%,470 RC103-147	CF1/4-470	ASE	4700-15-4700	1
R08	RES,C,1/4W,5%,33K RC103-333	CF1/4-33K	ASE	4700-15-3302	1
WAVETEK PARTS LIST		TITLE 50 MHZ HARMONIC MARKER, M6H-50		ASSEMBLY NO. 1114-00-0100 PAGE: 2	REV C

REFERENCE DESIGNATORS	PART DESCRIPTION	ORIG-MFGR-PART-NO	MFGR	WAVETEK NO.	QTY/PT
R09	RES,C,1/4W,5%,1M RC103-510	CF1/4-1M	ASE	4700-15-1004	1
R10	RES,C,1/4W,5%,1K RC103-210	CF1/4-1K	ASE	4700-15-1001	1
R11	RES,C,1/4W,5%,8.2K RC103-282	CF1/4-8.2K	ASE	4700-15-8201	1
R12	RES,C,1/4W,5%,15K RC103-315	CF1/4-15K	ASE	4700-15-1502	1
R13	RES,C,1/4W,5%,1.5M RC103-515	CF1/4-1.5M	ASE	4700-15-1504	1
R14	RES,C,1/4W,5%,10K RC103-310	CF1/4-10K	ASE	4700-15-1002	1
R15	POT,20K RP124-320	WA2G0328-203MA	A-B	4610-10-7203	1
R16	RES,C,1/4W,5%,100K RC103-410	CF1/4-100K	ASE	4700-15-1003	1
X1	CRYSTAL,XX000-331	X33W-00.00000	W-I	2310-00-0331	1
WAVETEK PARTS LIST		TITLE 50 MHZ HARMONIC MARKER, M6H-50		ASSEMBLY NO. 1114-00-0100 PAGE: 3	REV C

REFERENCE DESIGNATORS	PART DESCRIPTION	ORIG-MFGR-PART-NO	MFGR	WAVETEK NO.	QTY/PT
C01	CAP,CER,47PF,1KV CD104-047	60U2J470J	MDC	1510-10-3470	1
C02	CAP,CER,20PF,1KV CD101-020	60CUG200J	MDC	1510-10-0200	1
C03	CAP,CER,120PF,1KV CD104-112	10TCU-T12	SPR	1510-10-3121	1
C04 C09	CAP,FT,500PF,20%250V CF104-150	4420-500PF	AER	1510-30-3501	2
C05	CAP,F.T.,470PF CF101-147	FA5C-4712	A-B	1510-30-0471	1
C08	CAP,VALUE DETERMINED IN CALIBRATION	CAP,TRIM	W-I	1519-99-9999	1
C10	CAP,CER,.01MF,100V CD103-310	68U103M	MDC	1510-10-2103	1
C11	CAP,CER,.05MF,100V CD103-350	TG-350	SPR	1510-10-2503	1
C12	CAP,F.T.,6.8PF CF102-R68	FA5C-6892	A-B	1510-30-1689	1
CR14	DIODE DG000-007	5082-2800	H-P	4809-02-0001	1
CR2	DIODE DG100-821	1N82AG	G-I	4807-01-0082	1
J1 J2	CONN JF000-005	37JR116-1	S-C	2110-03-0002	2
L2	CHOKE,2.2MH,10% LA005-R22	08N2R2K	ASE	1810-03-0229	1
WAVETEK PARTS LIST		TITLE SING FREQ MKR M6S-3	ASSEMBLY NO. 1114-00-0045 PAGE: 1		REV A

REFERENCE DESIGNATORS	PART DESCRIPTION	ORIG-MFGR-PART-NO	MFGR	WAVETEK NO.	QTY/PT
Q1 Q2	TRANS QA038-541	2N3854A	G-E	4901-03-8541	2
R1	RES,C,1/4W,5%,47K RC103-347	CF1/4-47K	ASE	4700-15-4702	1
R2	RES,C,1/4W,5%,56 RC103-056	CF1/4-56	ASE	4700-15-5609	1
R3 R4	RES,C,1/4W,5%,1.5K RC103-215	CF1/4-1.5K	ASE	4700-15-1501	2
R5	RES,C,1/4W,5%,180K RC103-418	CF1/4-180K	ASE	4700-15-1803	1
R6	RES,C,1/4W,5%,470K RC103-447	CF1/4-470K	ASE	4700-15-4703	1
R7 R9	RES,C,1/4W,5%,10K RC103-310	CF1/4-10K	ASE	4700-15-1002	2
R8	POT,20K RP124-320	WA26032S-203MA	A-B	4610-10-7203	1
X1	CRYSTAL,XX000-331	X33W-00.00000	W-I	2310-00-0331	1
WAVETEK PARTS LIST		TITLE SING FREQ MKR M6S-3	ASSEMBLY NO. 1114-00-0045 PAGE: 2		REV A

REFERENCE DESIGNATORS	PART DESCRIPTION	ORIG-MFGR-PART-NO	MFGR	WAVETEK NO.	QTY/PT
C01	CAP,CER,47PF,1KV CD104-047	60U2J470J	MDC	1510-10-3470	1
C02	CAP,CER,20PF,1KV CD101-020	60C0G200J	MDC	1510-10-0200	1
C03	CAP,CER,120PF,1KV CD104-112	10TCU-T12	SPR	1510-10-3121	1
C04 C06 C09	CAP,FT,500PF,20%250V CF104-150	4420-500PF	AER	1510-30-3501	3
C05	CAP,F.T.,470PF CF101-147	FA5C-4712	A-B	1510-30-0471	1
C07	CAP,VAR,4-20PF,250V CV105-020	10S-TRIKO-05-4-20PF	STR	1510-70-4200	1
C08	CAP,VAR,CER,1/6PF CV106-R60	2222-802-96072	M-E	1510-70-5060	1
C10	CAP,CER,.01MF,100V CD103-310	68U103M	MDC	1510-10-2103	1
C11	CAP,CER,.05MF,100V CD103-350	TG-350	SPR	1510-10-2503	1
C12	CAP,F.T.,6.8PF CF102-R68	FA5C-6892	A-B	1510-30-1689	1
CR1 CR2	DIODE DG100-821	1N82AG	G-I	4807-01-0082	2
J1 J2	CONN JF000-005	37JR116-1	S-C	2110-03-0002	2
WAVETEK PARTS LIST		TITLE SING FREQ MKR M6S-4	ASSEMBLY NO. 1114-00-0046		REV A
PAGE: 1					

REFERENCE DESIGNATORS	PART DESCRIPTION	ORIG-MFGR-PART-NO	MFGR	WAVETEK NO.	QTY/PT
L2	CHOKE,2.2MH,10% LA005-R22	08N2R2K	ASE	1810-03-0229	1
Q1 Q2	TRANS QA038-541	2N3854A	G-E	4901-03-8541	2
R1	RES,C,1/4W,5%,47K RC103-347	CF1/4-47K	ASE	4700-15-4702	1
R2	RES,C,1/4W,5%,56 RC103-056	CF1/4-56	ASE	4700-15-5609	1
R3	RES,C,1/4W,5%,1.5K RC103-215	CF1/4-1.5K	ASE	4700-15-1501	1
R5	RES,C,1/4W,5%,180K RC103-418	CF1/4-180K	ASE	4700-15-1803	1
R6	RES,C,1/4W,5%,470K RC103-447	CF1/4-470K	ASE	4700-15-4703	1
R7 R9	RES,C,1/4W,5%,10K RC103-310	CF1/4-10K	ASE	4700-15-1002	2
R8	POT,20K RP124-320	WA2G032S-203MA	A-B	4610-10-7203	1
X1	CRYSTAL,XX000-331	X33W-00.00000	W-I	2310-00-0331	1
WAVETEK PARTS LIST		TITLE SING FREQ MKR M6S-4	ASSEMBLY NO. 1114-00-0046		REV A
PAGE: 2					

REFERENCE DESIGNATORS	PART DESCRIPTION	ORIG-MFGR-PART-NO	MFGR	WAVETEK NO.	QTY/PT
C1	CAP,F.T.,470PF CF101-147	FASC-4712	A-B	1510-30-0471	1
C2	CAP,FT,500PF,20%250V CF104-150	4420-500PF	AER	1510-30-3501	1
C3	CAP,CER,,01MF,100V CD103-310	68U103M	MDC	1510-10-2103	1
C4	CAP,CER,,05MF,100V CD103-350	TG-S50	SPR	1510-10-2503	1
C5	CAP,F.T.,6.8PF CF102-R68	FASC-6892	A-B	1510-30-1689	1
CR1	DIODE DG100-821	1N82AG	G-I	4807-01-0082	1
J1 J2 J3	CONN JF000-005	37JR116-1	S-C	2110-03-0002	3
L1	FERRITE CHOKE LA009-004	T1255-1	HYT	1810-05-0001	1
Q1	TRANS QA038-541	2N3854A	G-E	4901-03-8541	1
R01	RES,C,1/4W,5%,47 RC103-047	CF1/4-47	ASE	4700-15-4709	1
R02	RES,C,1/4W,5%,51 RC103-051	CF1/451	ASE	4700-15-5109	1
R03 R05	RES,C,1/4W,5%,470 RC103-147	CF1/4-470	ASE	4700-15-4700	2
R04	RES,C,1/4W,5%,150 RC103-115	CF1/4-150	ASE	4700-15-1500	1
WAVETEK PARTS LIST		TITLE EXT,MKR MODULE,M6C	ASSEMBLY NO. 1114-00-0124 PAGE: 1		REV A

REFERENCE DESIGNATORS	PART DESCRIPTION	ORIG-MFGR-PART-NO	MFGR	WAVETEK NO.	QTY/PT
R06	RES,C,1/4W,5%,180K RC103-418	CF1/4-180K	ASE	4700-15-1803	1
R07	RES,C,1/4W,5%,470K RC103-447	CF1/4-470K	ASE	4700-15-4703	1
R08 R10	RES,C,1/4W,5%,10K RC103-310	CF1/4-10K	ASE	4700-15-1002	2
R09	POT,20K RP124-320	WA2G032S-203MA	A-B	4610-10-7203	1
WAVETEK PARTS LIST		TITLE EXT,MKR MODULE,M6C	ASSEMBLY NO. 1114-00-0124 PAGE: 2		REV A

SECTION 6

SCHEMATICS

6.1 INTRODUCTION

This section contains all schematics for the instrument. A schematic index is given in Section 6.4.

6.2 SCHEMATIC NOTES

The following notes and abbreviations pertain to all schematics. Additional notes pertaining to specific schematics

are included on each schematic if required.

All values are shown in the following units unless otherwise specified.

Components	Units
Resistor	ohms
Capacitor	picofarads
Inductor	microhenries



Denotes DC voltage reading in volts unless otherwise specified.



Denotes high impedance crystal detector reading in volts unless otherwise specified.



Denotes 50 ohm crystal detector reading in volts unless otherwise specified.



Signal or voltage source.



Connects to indicated signal or voltage source.

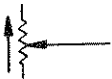

Arrow indicates clockwise rotation of wiper.

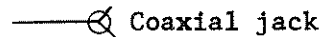

Coaxial jack

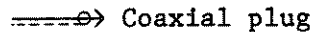

Coaxial plug

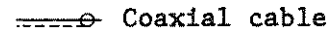

Coaxial cable

* Factory adjusted part.

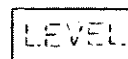

Denotes a front-panel device.



Denotes a rear-panel device.

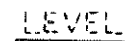

Denotes a PC board adjustment or accessible module adjustment.

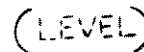

Denotes an internal module adjustment not accessible without removing module cover.

SCHEMATICS

6.3 ABBREVIATION CODE

A	Assembly	IF	intermediate frequency	Ω	ohm
A	ampere	J	jack	OC	opto-coupler
AC	alternating current	K	relay	P	plug
C	capacitor	kHz	kilohertz	pp	peak-to-peak
CR	diode	k Ω	kilohm	pF	picofarad
CW	continuous wave	kV	kilovolt	Q	transistor
cw	clockwise	kW	kilowatt	R	resistor
dB	decibel	L	inductor	RF	radio frequency
dBm	decibel referred to 1 mW	MHz	megahertz	RMS	root-mean-square
dBmV	decibel referred to 1 mV	M Ω	megohm	R.P.	rear panel
DC	direct current	μ F	microfarad	S	switch
DS	indicating device, lamp	μ A	microampere	T	transformer
F	farad	μ H	microhenry	T.P.	test point
F.P.	front panel	M	meter	V	volt
H	henry	mA	milliampere	VA	voltampere
Har	harmonic	mH	millihenry	W	watt
Hz	hertz	mV	millivolt	X	crystal
IC	integrated circuit	mW	milliwatt		

6.4 SCHEMATIC INDEX

<u>SCH. NO.</u>	<u>ASSY.</u>	<u>NAME</u>
1	1060	WIRING DIAGRAM
2	C001	RATE GENERATOR CARD
3	C004	LINE RATE CARD
4	M9Y(A)-1	SWEEP OSCILLATOR
5	M13J	PULSE MARKERS
6	B012	TILT
7	B014	NOTCH / TILT
8	M6H-1	HARMONIC MARKER (1 MHz)
9	M6H-5-50	HARMONIC MARKER (5-50 MHz)
10	M6S	SINGLE FREQ. MARKER
11	M6C	EXTERNAL MARKER

1060 SERIES
WIRING DIAGRAM

REV A

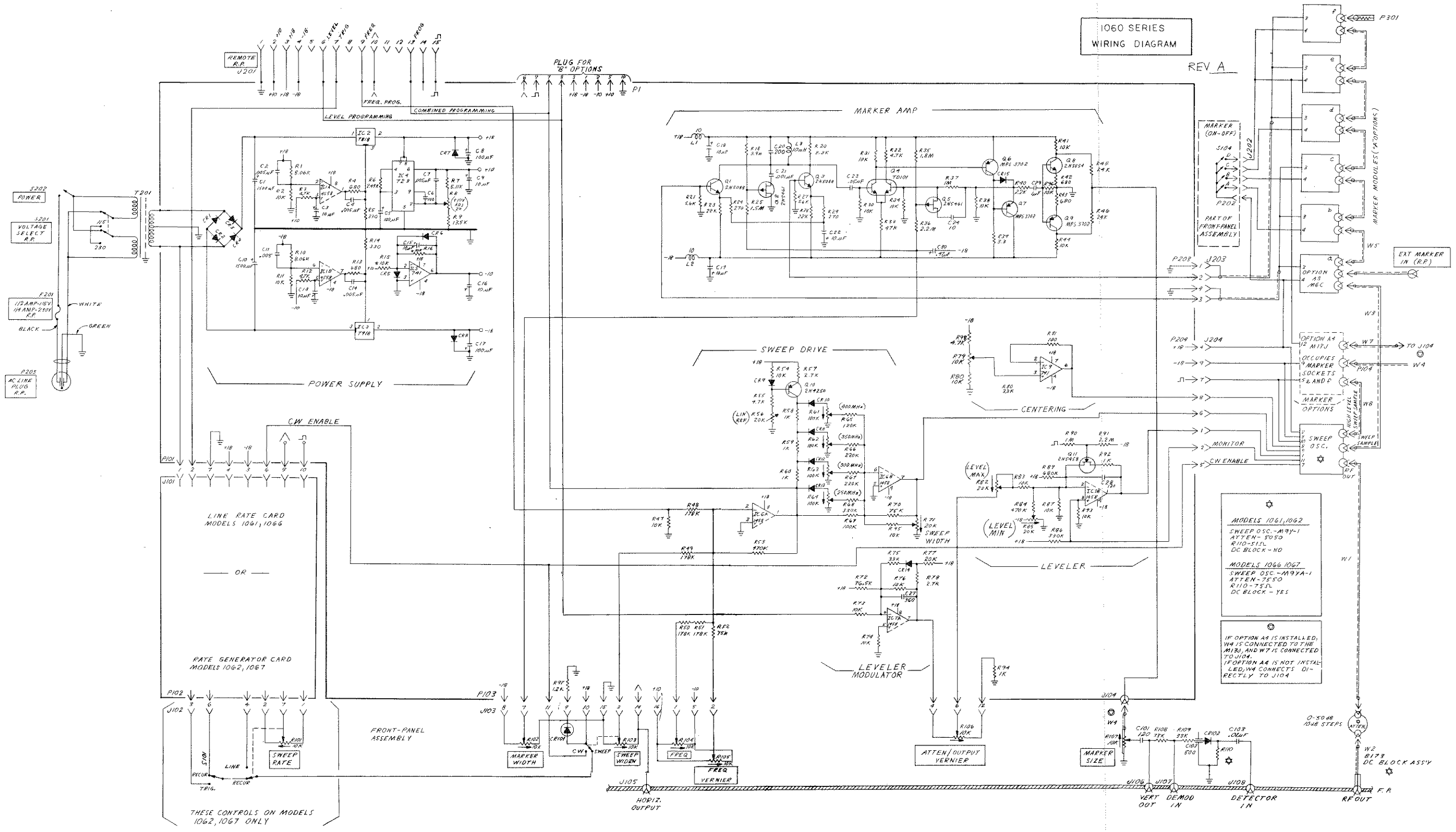

MODELS 1061, 1062
SWEEP OSC. - M9Y-1
ATTEN - 5050
R110 - 51L
DC BLOCK - NO

MODELS 1066, 1067
SWEEP OSC. - M9YA-1
ATTEN - 7550
R110 - 75L
DC BLOCK - YES

IF OPTION A4 IS INSTALLED,
W4 IS CONNECTED TO THE
W1B, AND W7 IS CONNECTED
TO J104.
IF OPTION A4 IS NOT INSTAL-
LED, W4 CONNECTS DI-
RECTLY TO J104.

THESE CONTROLS ON MODELS
1062, 1067 ONLY

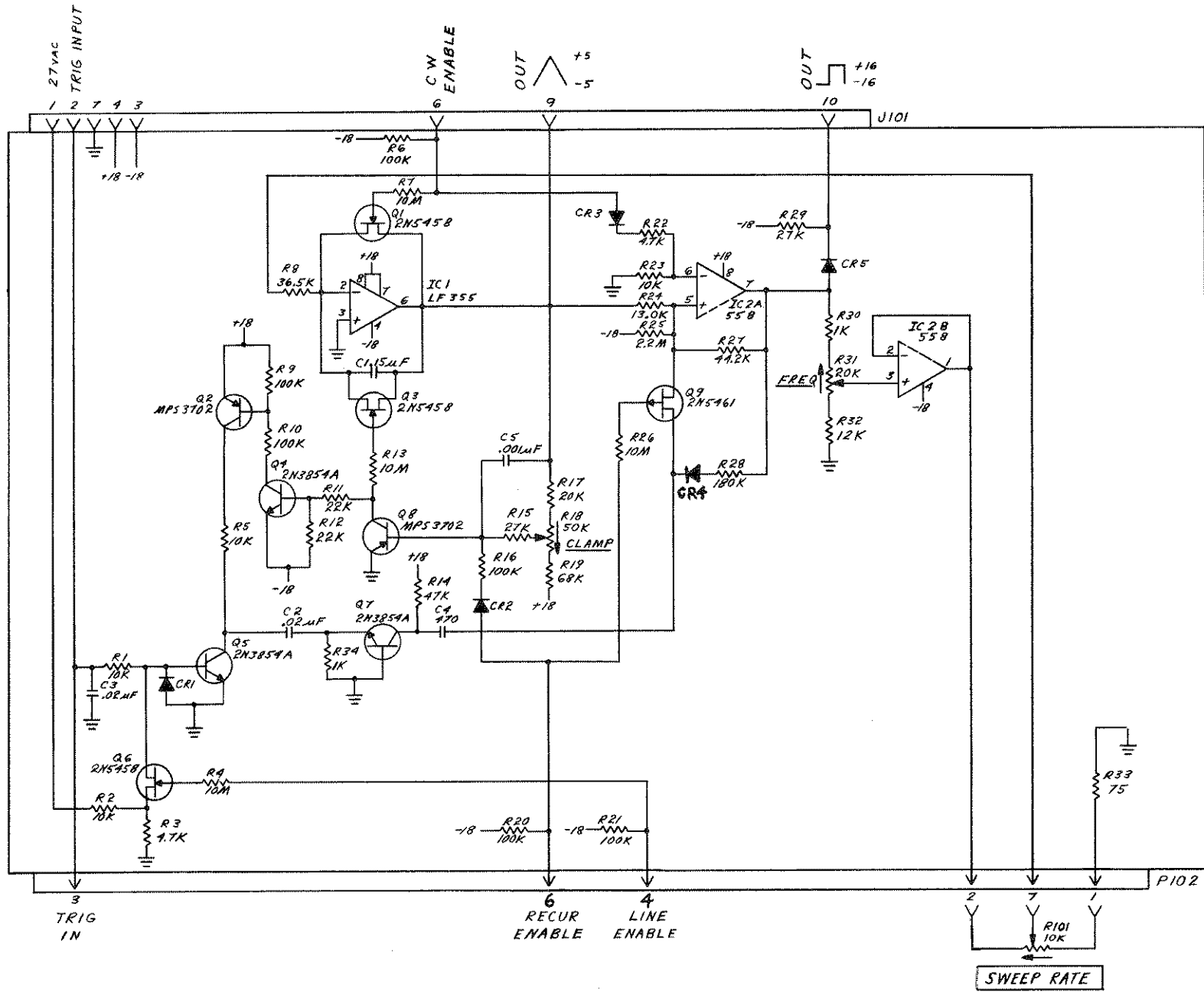

SCHEMATIC 2 - C001
RATE GENERATOR CARD

REV. B

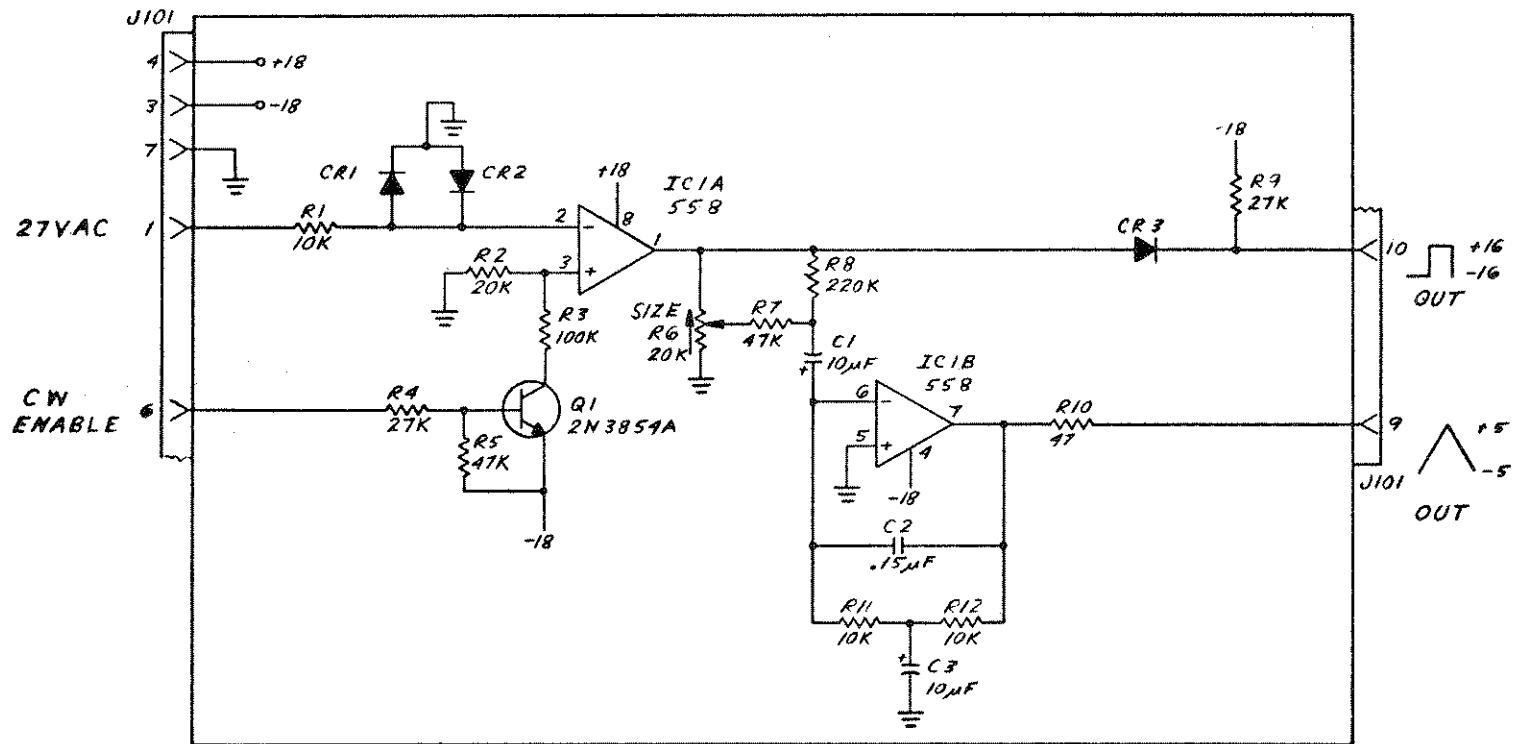

SCHEMATIC 3 - C004
LINE RATE CARD

**SCHEMATIC 4 - M9Y(A)-1
SWEEP OSCILLATOR**

REV. H

NOTE 1: FOR Σ OF 75 Ω , R66 IS CHANGED TO 75 AND THE "X" SUFFIX IS ADDED TO THE MODULE NUMBER

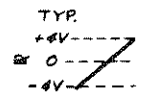
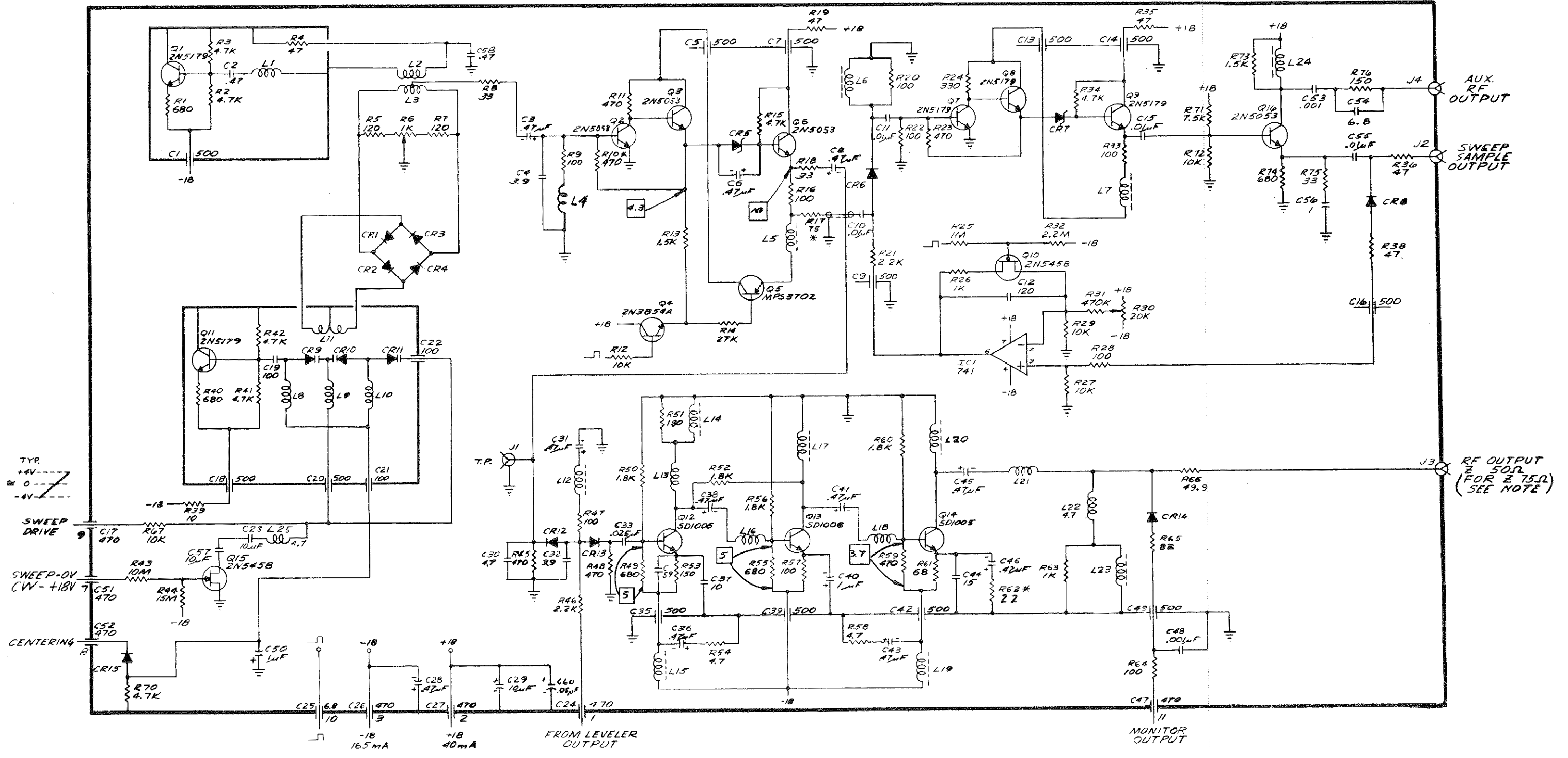

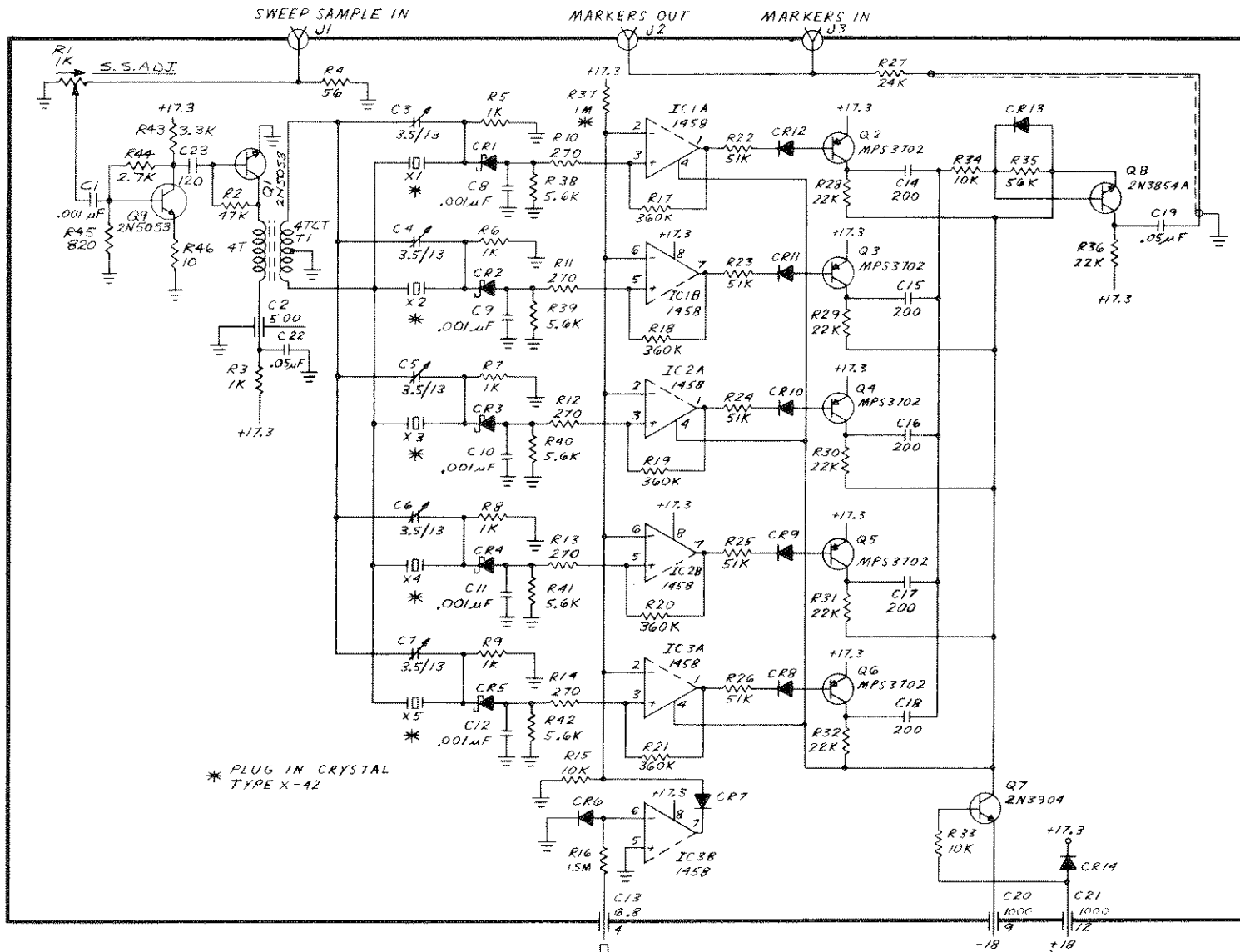

SCHEMATIC 5 - M13J
PULSE MARKERS

REV B

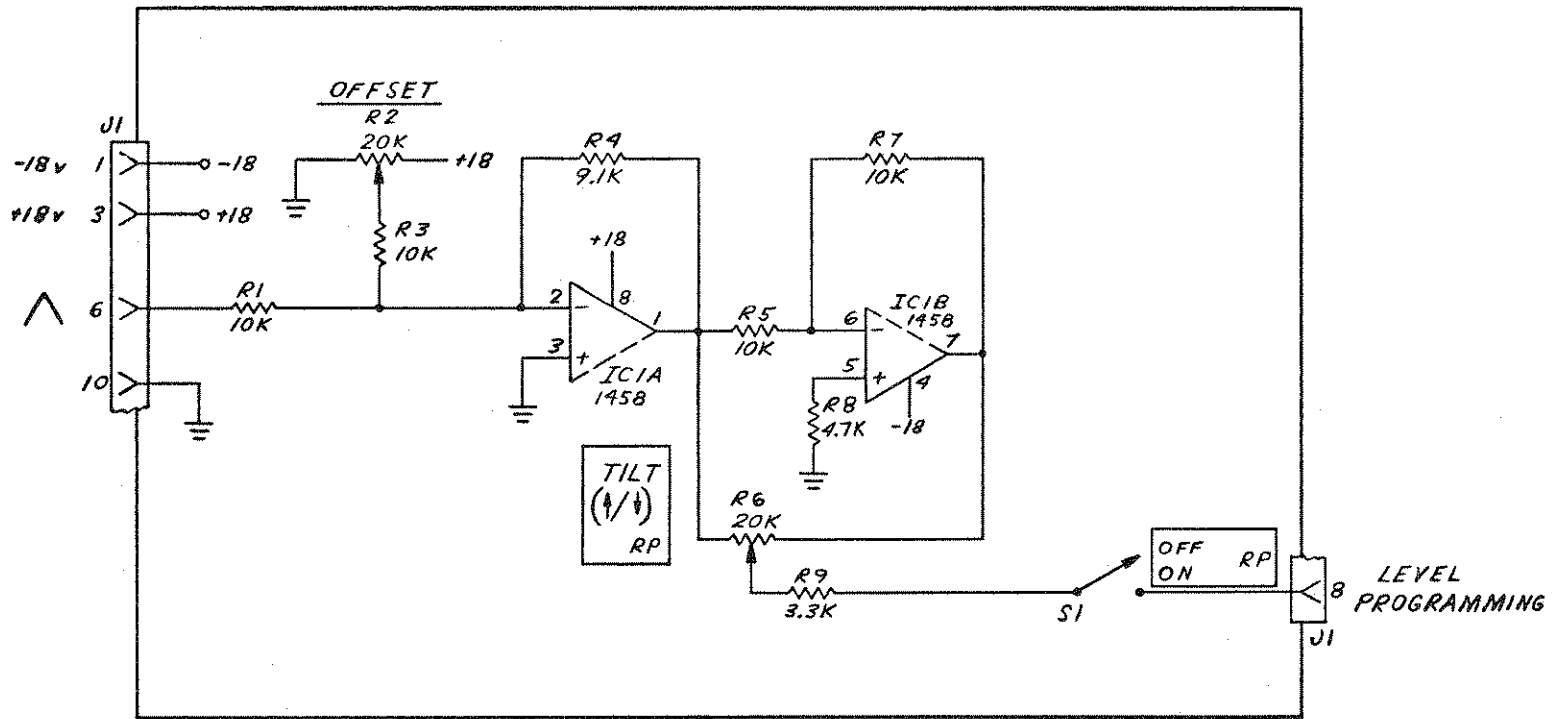

SCHEMATIC 6 - B012
 TILT

SCHEMATIC 7 - B014
NOTCH / TILT

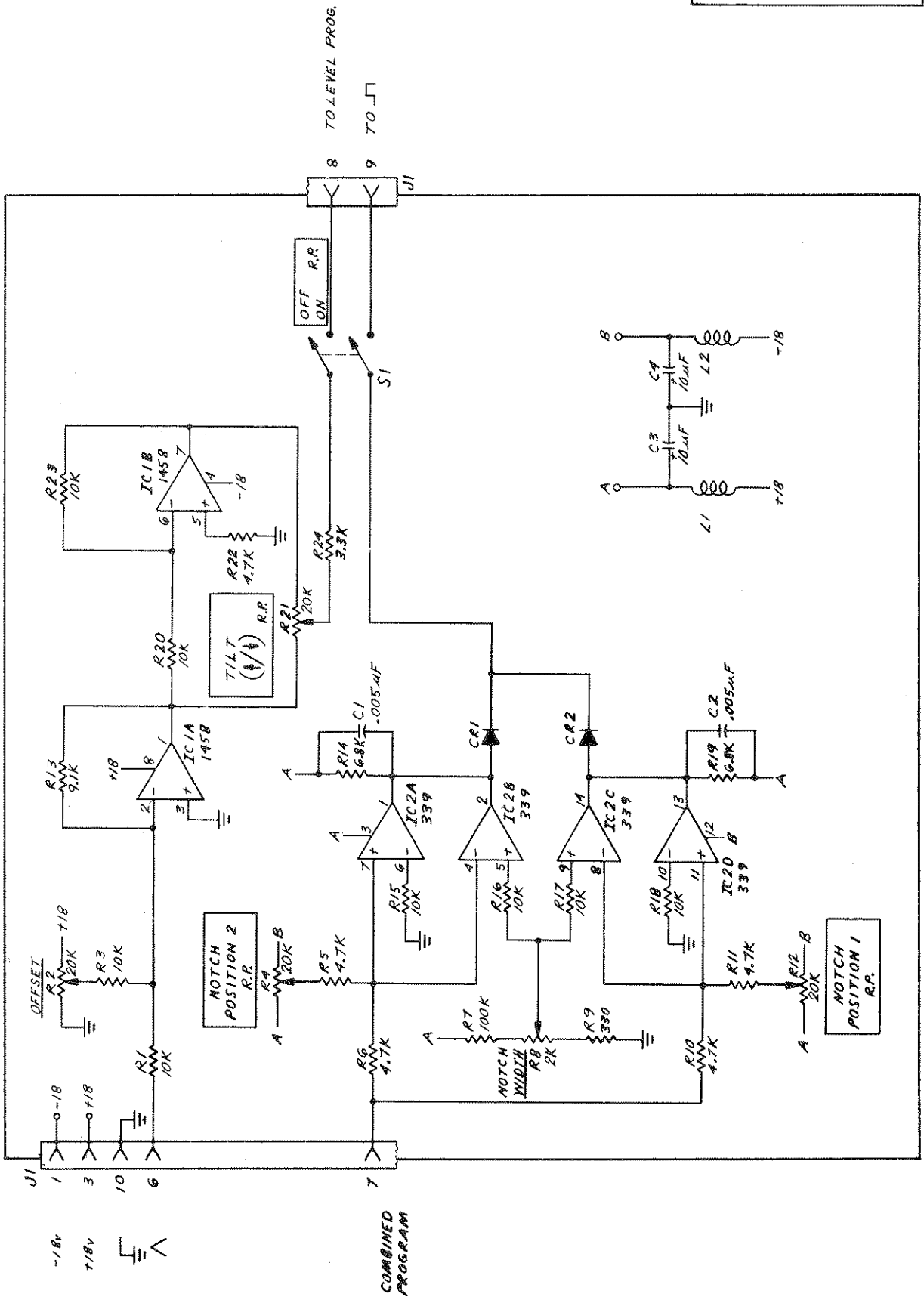

SCHEMATIC 8 - M6H-1
HARMONIC MARKER (1 MHZ)

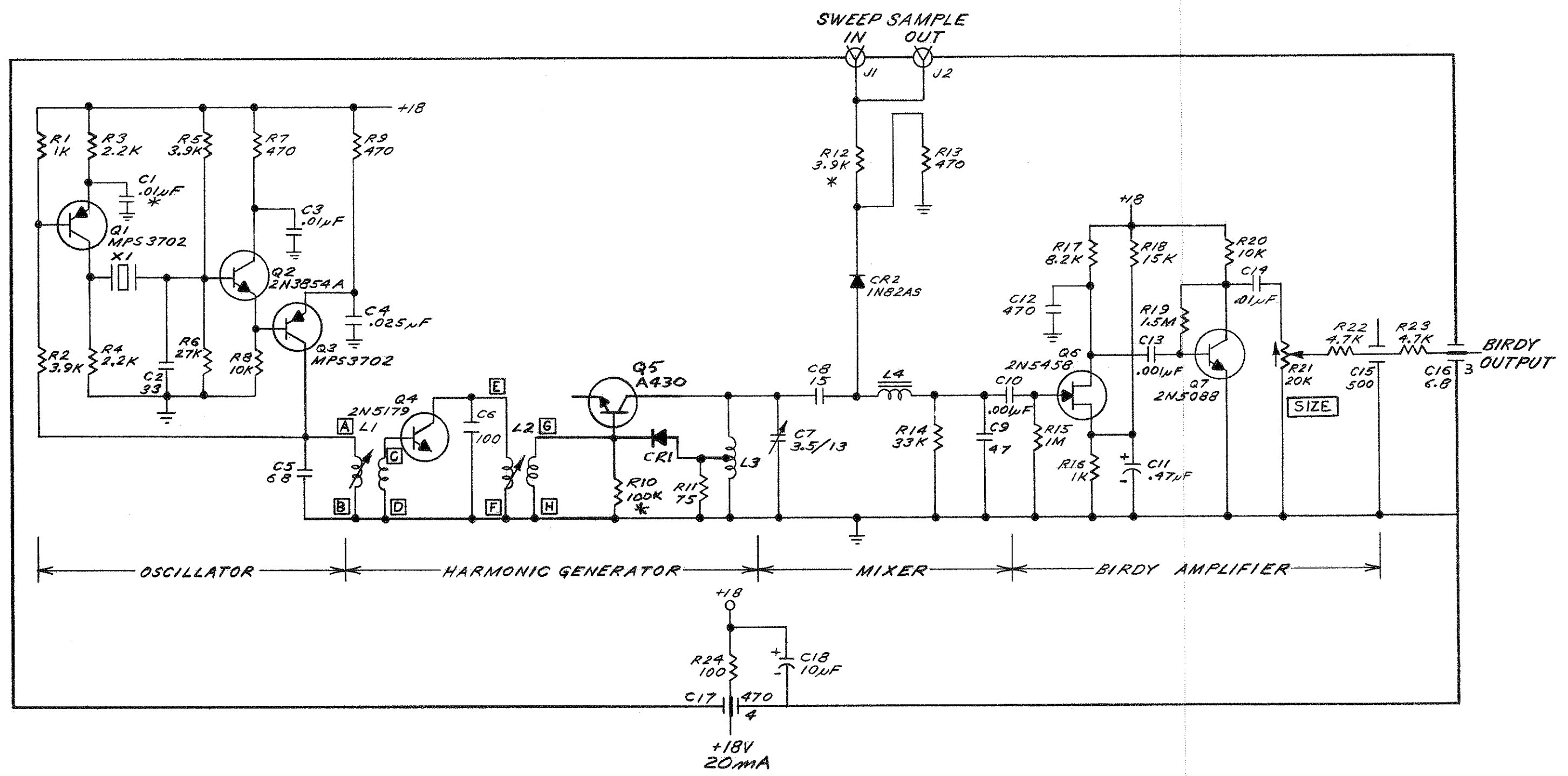

SCHEMATIC 9 - M6H-5-50
HARMONIC MARKER (5-50 MHZ)

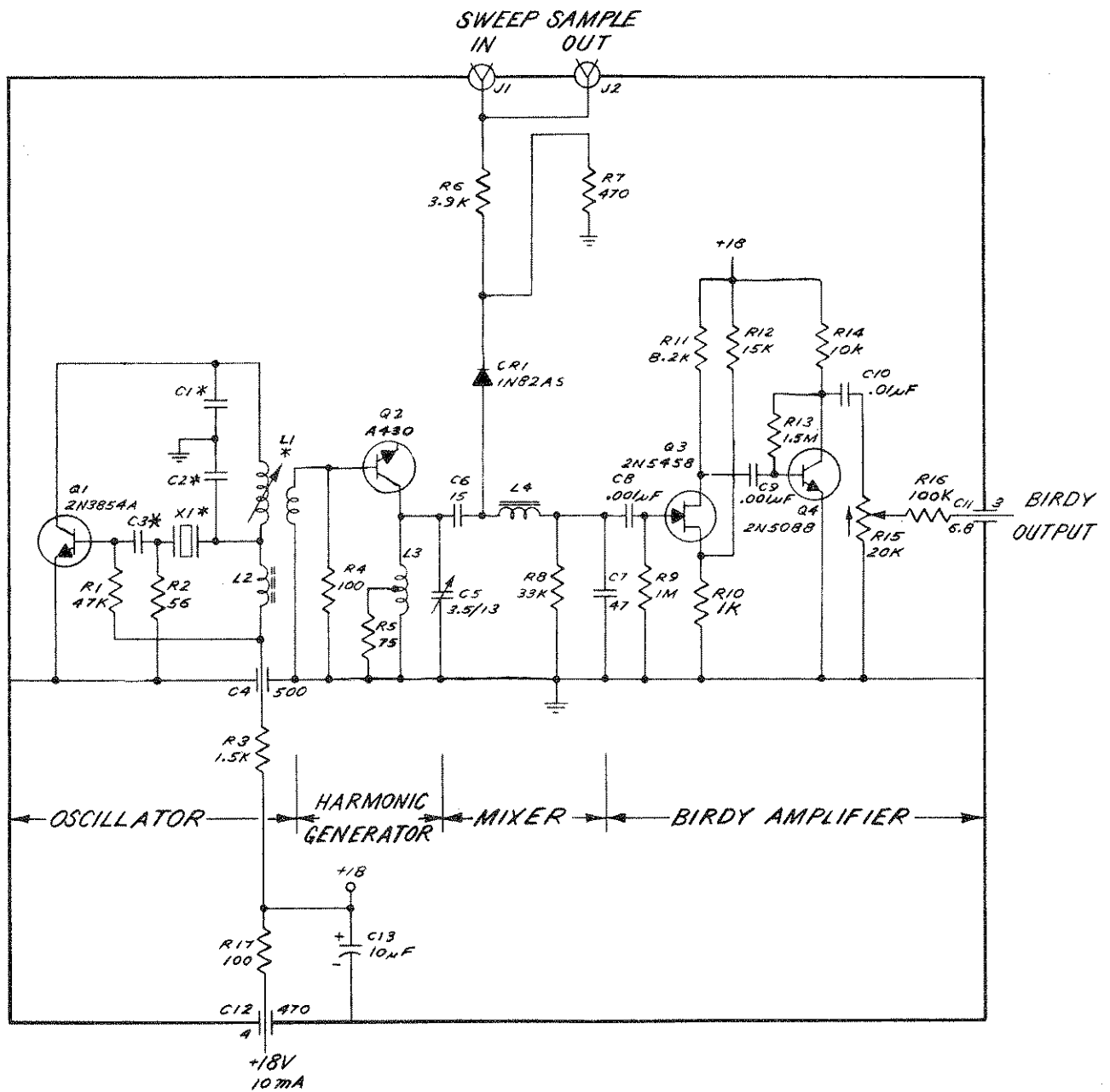

SCHEMATIC 10 - M6S
SINGLE FREQ. MARKER

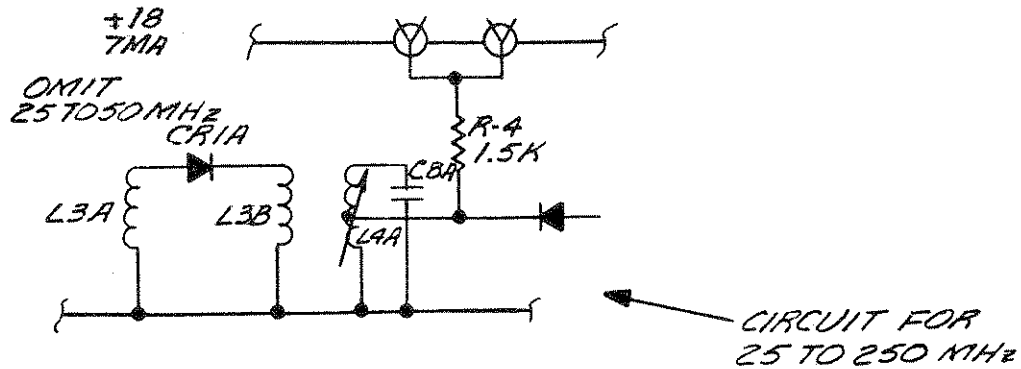
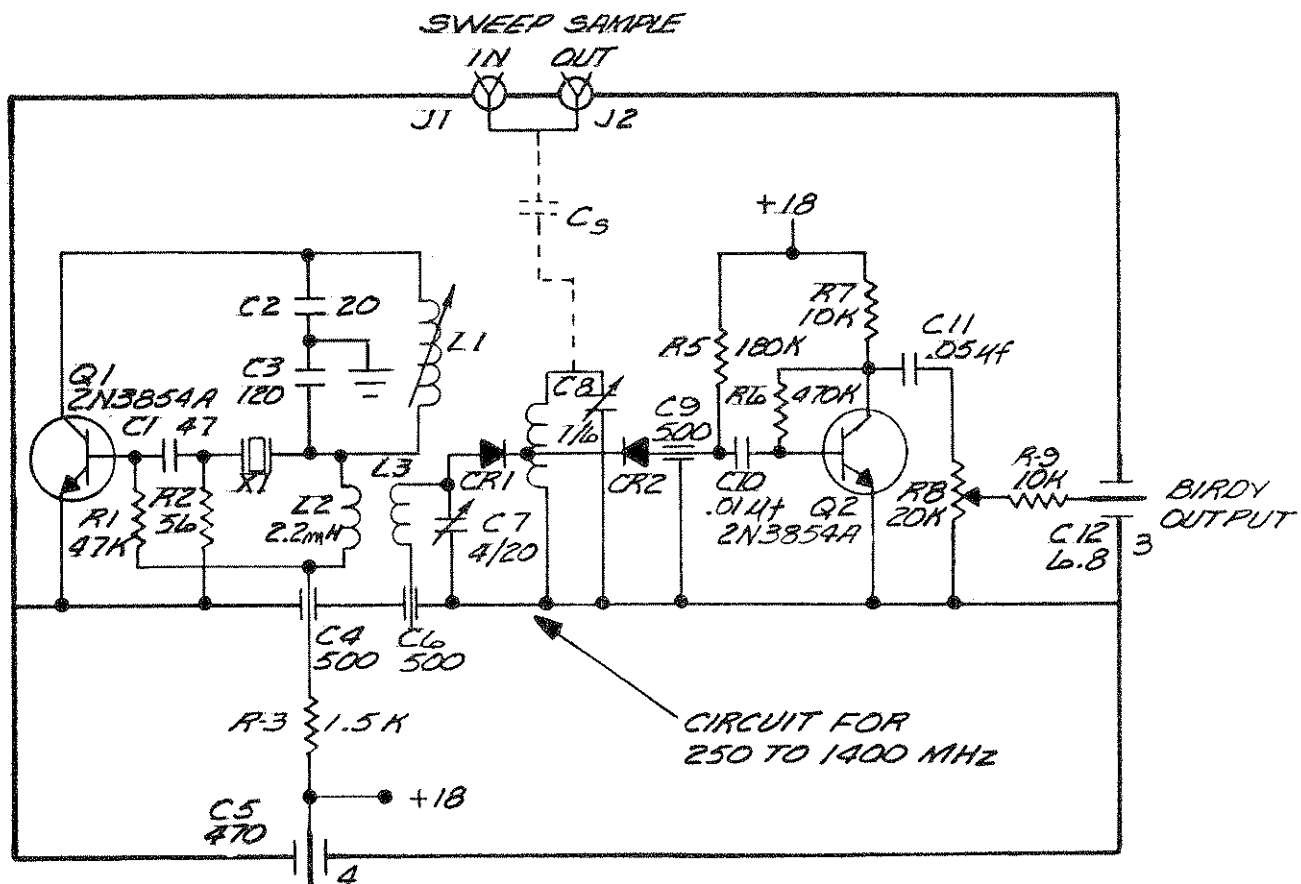

SCHEMATIC 11 - M6C
EXTERNAL MARKER

