

SERVICE MANUAL

AKAI TAPE RECORDER

MODEL

1700

AND

1710

TABLE OF CONTENTS

| | | |
|-----|---|----|
| I | SPECIFICATIONS | 1 |
| I | HOW TO MEASURE DESIGNATED VALUES OF SPECIFICATIONS | 2 |
| II | LOCATION OF CONTROLS | 3 |
| IV | DISASSEMBLY OF TAPE TRANSPORT UNITS AND AMPLIFIERS..... | 4 |
| V | TRANSPORT MECHANISM | 6 |
| VI | ADJUSTMENT OF TAPE TRANSPORT UNIT | 9 |
| VI | ADJUSTMENT OF AMPLIFIER | 10 |
| VII | MAINTENANCE PROCEDURES | 11 |
| IX | LIST OF REPLACEMENT PARTS | 12 |
| X | EXPLODED VIEW OF COMPONENT PARTS | 14 |
| XI | TROUBLE SHOOTING CHART | 21 |
| XII | SCHEMATIC DIAGRAM | 25 |
| XII | CONNECTING DIAGRAM | 26 |

I SPECIFICATIONS

MODEL

NUMBER: Akai Model 1700, portable 4-track stereo tape recorder.

WEIGHT (NET

IN CARTON): 33 lbs (15 kg) without accessories.

DIMENSIONS : 13-1/2" (H) × 13-1/2" (W) × 9" (D) case closed.

POWER RE-

QUIREMENTS: A. C. 100, 110, 120, 200, 220 or 240 volts interchangeable. 50-60 cycles.

POWER CON-

SUMPTION: 80 VA.

RECORDING

SYSTEM: Inline 4 track stereo and 4-track monaural recording.

PLAYBACK

SYSTEM: Inline 4-track stereo, monaural playback.

TAPE SPEED : Three speeds; 7-1/2" (19 cm), 3-3/4" (9.5 cm) and 1-7/8" (4.75 cm) per second. (15" per second with an optional accessory capstan and pinch wheel.)

TAPE SPEED

DEVIATION: Less than ± 3 per cent at all tape speeds.

WOW AND

FLUTTER: Less than 0.2 % at 7-1/2 ips. R.M.S.
Less than 0.3 % at 3-3/4 ips. R.M.S.
Less than 0.45 % at 1-7/8 ips. R.M.S.

FAST FORWARD AND REWIND

TIME: 150 seconds for 1,200 ft. tape at 50 cycles and 120 seconds at 60 cycles.

FREQUENCY

RESPONSE: 40 to 18,000 cps. at 7-1/2 ips;
± 3 db. 80 to 12,000 cps. at 7-1/2 ips;
± 3 db. 80 to 10,000 cps. at 3-3/4 ips;
± 4 db. 80 at 4,000 cps. at 1-7/8 ips.

DISTORTION : Within 4 % at 1,000 cps, 0 VU (total harmonic)

SIGNAL-TO-

NOISE RATIO: 40 db below recorded level signal at all speeds.

CROSS TALK : Within 55 db between each track.

CHANNEL

SEPARATION: Better than 80 db at 1,000 cps +3 VU.

POWER INPUT

LEVELS: Microphone input level
-55 db (VR. max.) at 1,000 cps.
Phono and radio input level
-40 db (VR. max.) at 1,000 cps.

POWER

OUTPUT: Pre-Amplifier output, 0.7 V at 1,000 cps, impedance more than 100 K ohms.
Main output, 34 dbm. up (in 600 ohms).

INSULATION

RESISTANCE: More than 50 MEG ohms.

INSULATION

YIELD

STRENGTH: More than one minute at A. C. 1,000 V.

MONITORING

SYSTEM: With headphone during recording.

MOTOR

: Condenser starting induction two-speed motor.
1/100 HP. Power factor, 70 per cent.
2,900 to 1,450 r.p.m. at 50 cps,
3,480 to 1,740 r.p.m. at 60 cps.

HEADS

: Inline 4-track stereo/monaural record-play head;
Impedance... 3,500 ohms ± 10 % at 1,000 cps.
4-track erase head;
Impedance... 4,000 ohms ± 15 % at 90 kc.

MICROPHONE

USED: Round dynamic microphone
Impedance... 50,000 ohms
Sensitivity... -55 db.
Frequency Response... 70 to 15,000 cps ± 10 db.

SPEAKER

INCLUDED: Two 5" × 7" dynamic speakers.
Impedance... 8 ohms
Allowable Input... 6 watts
Frequency Response... 80 to 12,000 cps, ± 10 db.

TUBES USED : 12AT7 × 2, 6BM8 × 2.

SILICON

DIODE USED: 150D × 2

REELS USED : Up to 7" reel

RECORDING

LEVEL

INDICATOR: Horizontal, A-model VU meter.

II HOW TO MEASURE DESIGNATED VALUES OF SPECIFICATIONS

TAPE SPEED

DEVIATION: Record the 1,000 cps. sine curve of the tape speed at rating speeds with a standard sound recorder (AMPEX 351A, for instance) which is little affected by the tape speed deviation throughout the whole length of the tape. Put this standard tape on the tape recorder under test for playing back, and measure its output by a counter, then convert the value into rating power frequency to evaluate the tape speed deviation.

For a rough measurement, the tape speed deviation can also be measured with a testing tape for speed by a stop watch.

WOW AND

FLUTTER: Playback the 3,000 cps. standard tape that guarantees wow and flutter within 0.07 per cent, and read the effective value on wow meter.

Since the sensibility of wow and flutter frequency below 2 cps. and above 5 cps. drops, the frequency over 5 cps. is put to 3 db/OCT circuit, and the frequency below 2 cps. is put to 6 db/OCT circuit for adjustment. This adjusted value is called auditory compensated value.

FREQUENCY

RESPONSE: Connect to the input terminal of the recorder, record a sine curve sweep (OVERALL FREQUENCY RESPONSE) frequency at 100 cps -10 db, from Audio Frequency Oscillator.

Adjust tone volume to flat, playback the tape by connecting VTVM to speaker output then read the frequency response to adjust a maximum deviation of 6 db.

TOTAL HARMONIC DISTORTION

FACTOR: Provide the input terminal of the recorder with 1,000 cps. sine curve signals and record these signals on a recording tape at the zero level on the recorder's VU meter.

Then playback the signals under the normal recording condition to measure the distortion factor by an oscillator. Remove the recording tape from the recorder, then read the noise level on the oscillator to get the required distortion factor by the following formula:

$$d_0 = d - d_1 - d_2$$

d_0 ...required

d ...overall distortion factor

d_1 ...noise level

d_2 ...distortion factor of the oscillator used

SIGNAL TO

NOISE: Playback the sine curve, 250 cps. tape recorded on a standard recorder on the recorder to measure the voltage. Remove the tape, then measure the noise level under the same condition. Calculate the ratio between the two in decibel.

OUTPUT:

Playback on the recorder the 1,000 cps. sine curve tape which was recorded at the zero VU level on a standard recorder. Terminate the test recorder with eight ohms.

Square the voltage reading, then divide the figure by eight ohms to get the r.m.s. power output.

CROSS TALK:

Record 1,000 cps. signal at +3 VU on the third track, then playback this signal through a 1,000 cps. Band Pass Filter.

Compare the output of tracks 1 and 3 in decibels.

III LOCATION OF CONTROLS

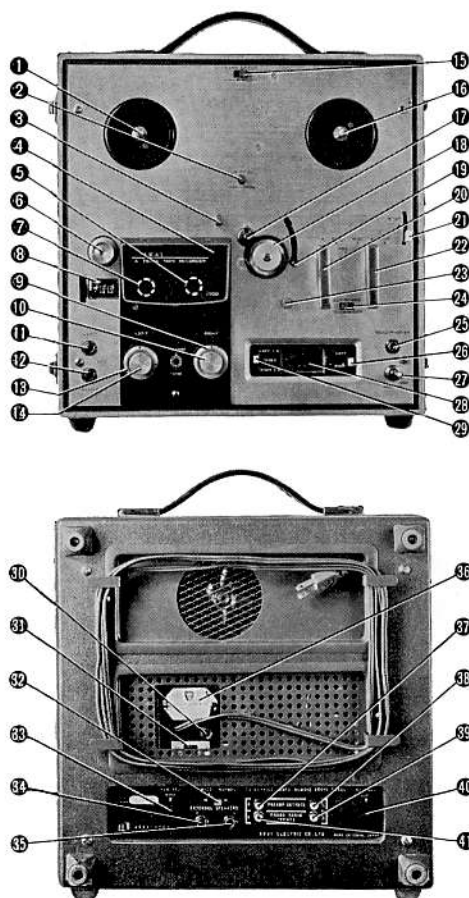

- | | |
|---------------------------------------|-----------------------------------|
| ① Supply reel shaft | ②② Rewind/Fast-forward switch |
| ② Cycle conversion switch | ②③ Record safety button |
| ③ Capstan storage post | ②④ Automatic stop switch |
| ④ Head cover | ②⑤ Stereo headphone jack |
| ⑤ Record/Play head | ②⑥ VU meter conversion switch |
| ⑥ Tape guide | ②⑦ Power switch |
| ⑦ Erase head | ②⑧ VU meter |
| ⑧ Index counter | ②⑨ Track selector switch |
| ⑨ Right channel volume control | ③⑩ Fuse post |
| ⑩ Right channel tone control | ③① Cycle conversion switch |
| ⑪ Left channel microphone input jack | ③② Speaker switch |
| ⑫ Right channel microphone input jack | ③③ Hum adjust (right) |
| ⑬ Left channel volume control | ③④ Speaker output jack (right) |
| ⑭ Left channel tone control | ③⑤ Speaker output jack (left) |
| ⑮ Speed change switch | ③⑥ Voltage selector switch |
| ⑯ Take-up reel shaft | ③⑦ Preamp output jack (right) |
| ⑰ Capstan shaft | ③⑧ Preamp output jack (left) |
| ⑱ Pinch wheel | ③⑨ Phono/Radio input jack (left) |
| ⑲ Automatic stop lever | ④⑩ Hum adjust (left) |
| ⑳ Record/Play switch | ④① Phono/Radio input jack (right) |
| ㉑ Instant stop lever | |

IV DISASSEMBLY OF TAPE TRANSPORT UNITS & AMPLIFIERS

- (1) Loosen the RETAINING SCREW (a) of PINCH ROLLER (b) using a phillips-headed screw driver to remove the PINCH ROLLER (b).

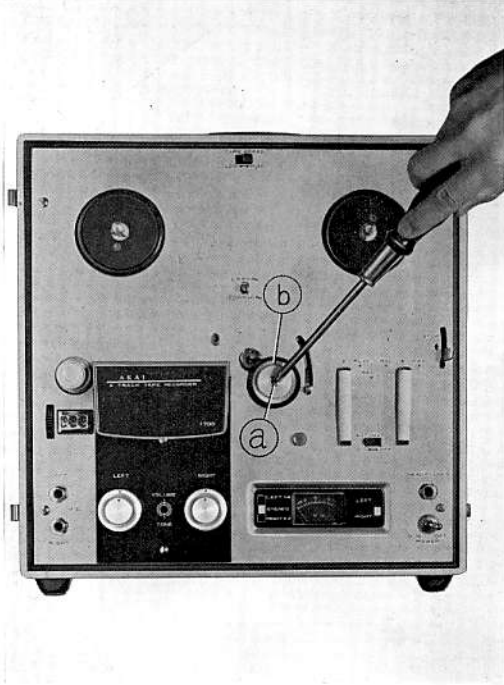

- (3) Loosen the SCREWS marked from (a) to (d) in order to remove DECK PANEL (P).

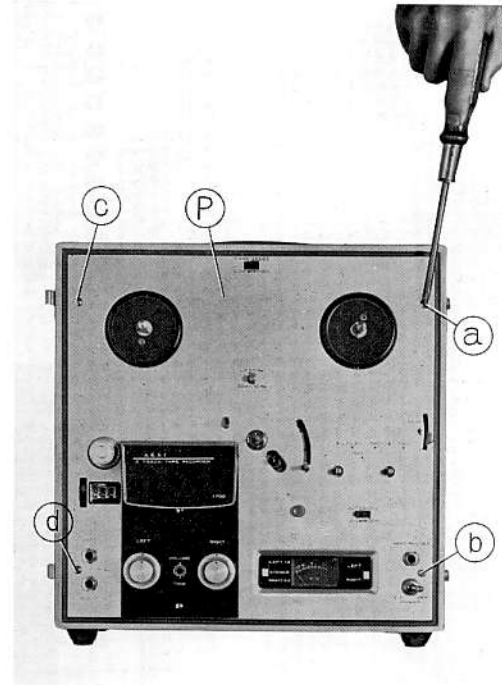

- (2) Remove the DECK CONTROL KNOBS (a) and (b) by loosening their retaining screws using a phillips-headed screw driver.

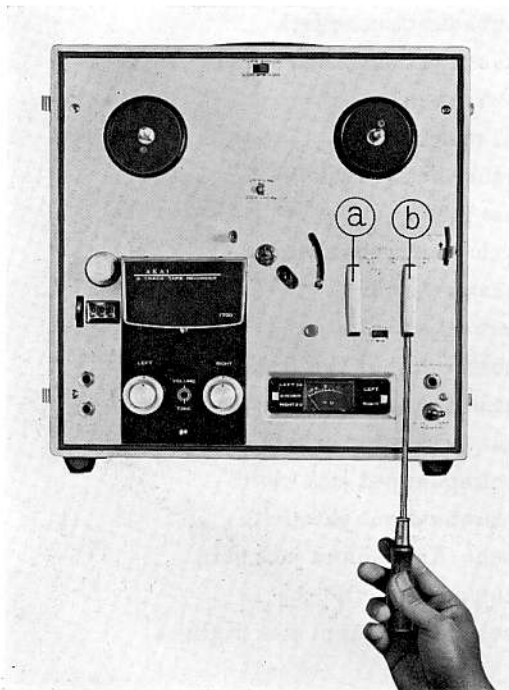

- (4) Loosen the SCREWS marked from (a) to (d).

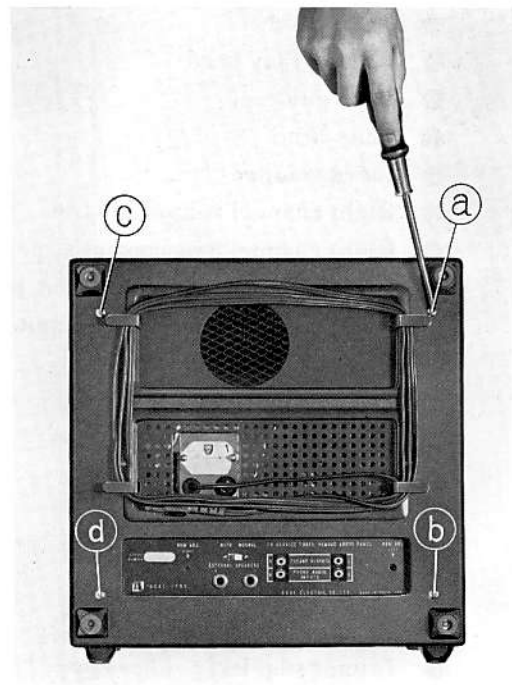

(5) Loosen the SCREWS marked from (a) to (d).

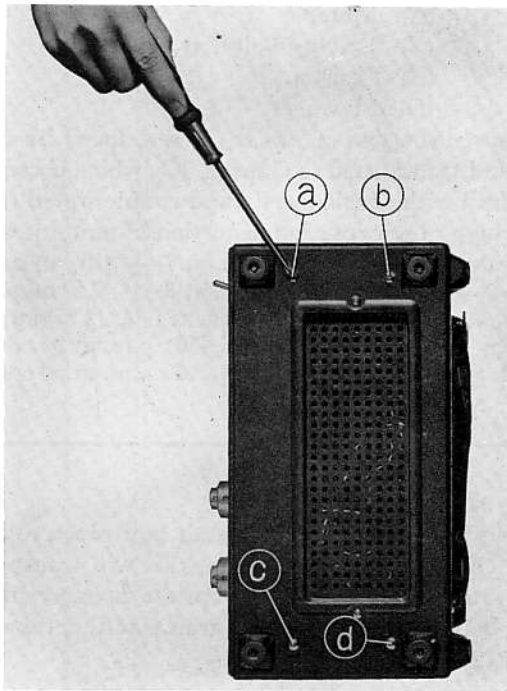

(6) Lift TAPE DECK and AMPLIFIER (D) from the cabinet (B).

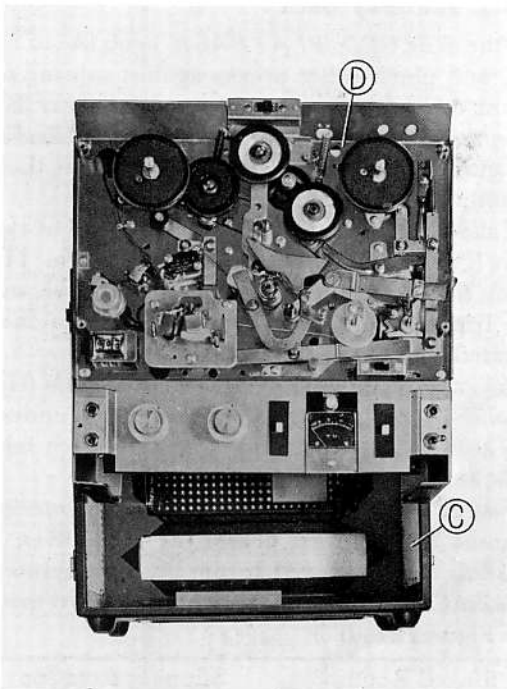

(7) Disconnect the PINS of speaker marked (a) and (d), the PLUGS of motor marked (e) and (f) and the PINS of head marked (g) and (j).

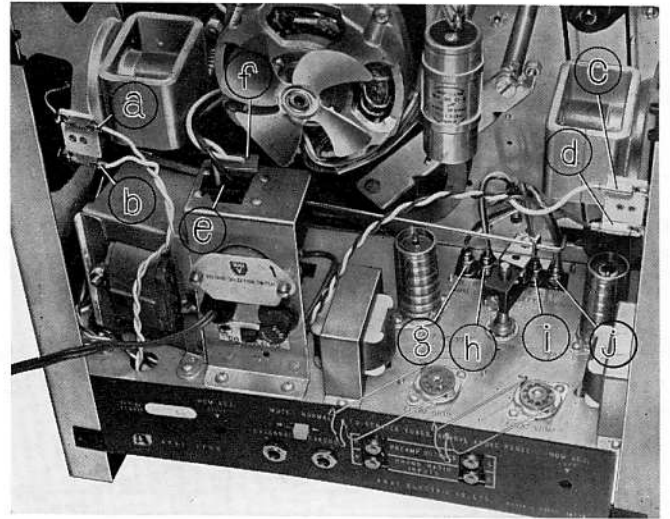

(8) Loosen the RETAINING SCREWS of deck frame marked from (a) to (d)

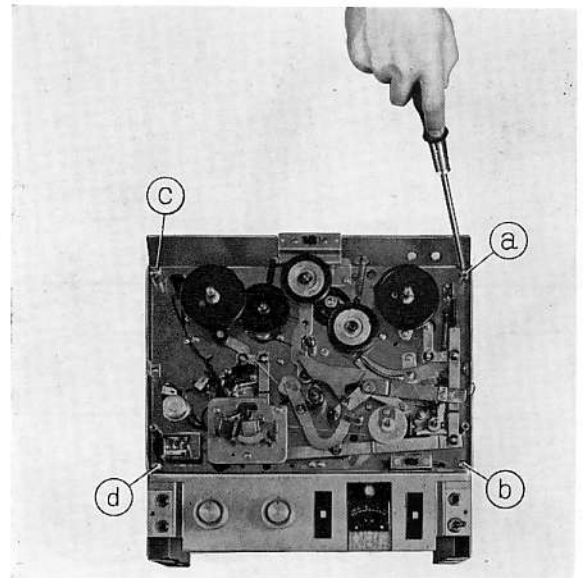

(9) Separate TAPE DECK (M) from AMPLIFIER (A).

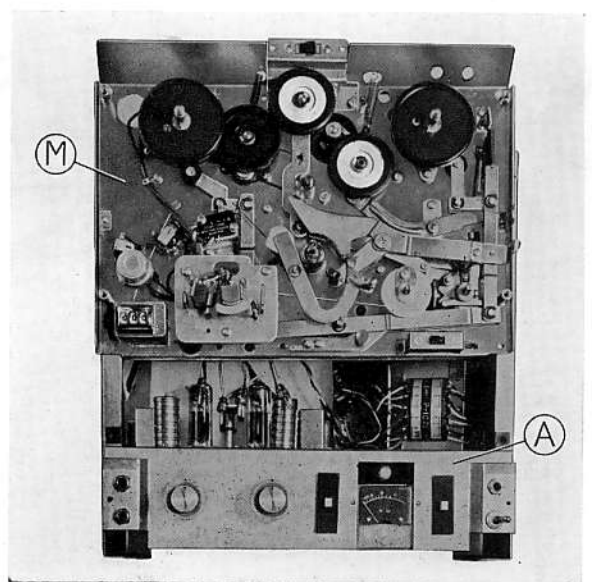

V TRANSPORT MECHANISM

Driving of Capstan

Figure 1.

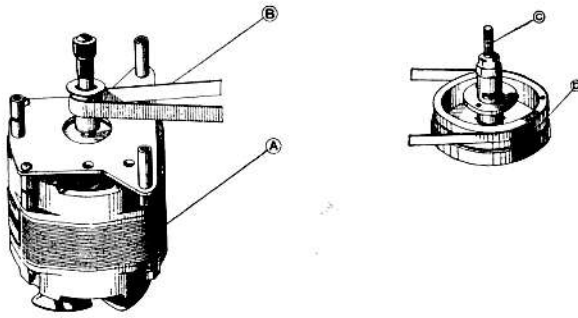

Fig. 1

- (A) Motor
- (B) Driving Belt (flat belt)
- (C) Capstan
- (D) Flywheel

High-speed rotation of *Motor* (A) is reduced by *Driving Belt* (B) and transmitted to *Capstan* (C), which is connected to *Flywheel* with ample inertia and enables rated rotation by absorbing minor rotation distortion of motor itself.

| | |
|------------------|---|
| Capstan Rotation | 606 r.p.m. at 7-1/2" (19 cm) per sec. |
| | 303 r.p.m. at 3-3/4" (9.5 cm) per sec. |
| | 151.5 r.p.m. at 1-7/8" (4.75 cm) per sec. |
| Motor Rotation | 2,900 to 1,450 r.p.m. at 50 cps. |
| | 3,480 to 1,740 r.p.m. at 60 cps. |

Driving of Pinch Roller

Put tape between rotating capstan and pinch roller and push pinch roller against capstan, this will transport the tape at rated speed. The appropriate pressure of pinch roller is between 1,000 to 1,150 grams at the tape speed of 7-1/2" (19 cm) per second.

Recording and Play Back

Turn the *RECORD, PLAYBACK* knob (A) to "PLAY" position, and pinch roller presses against capstan to move tape at the rated speed. At the same time, *Idler* (B) moves between *Motor Bushing* (C) and the *Take-Up Reel Spindle* (D) to transmit the motor rotation to (D) so that the tape is moved and wound on the take-up reel.

The *Take-Up Reel Spindle Base* is made up of two plastic rollers (1 and 2) with a clutch felt in between. The *Idler* is rotating the plastic roller (2) under. Therefore, the tape-winding friction is adjusted by the slipping of the felt to enable rated winding of the tape.

On the other hand, the *Supply Reel Spindle* (H) has a *Brake roller* (E) hung on the *Plastic Roller* (4) under which provides appropriate back tension by the clutch felt slipping to the rotation of the *Pulley* (3) above.

To prevent accidental erasure, the *Record Interlock Button* (F) must be depressed before the *RECORD, PLAYBACK* knob can be moved to the "REC" position. The *Safety device* (G) is depressed to enter the record mode.

(See Figures 2 and 3)

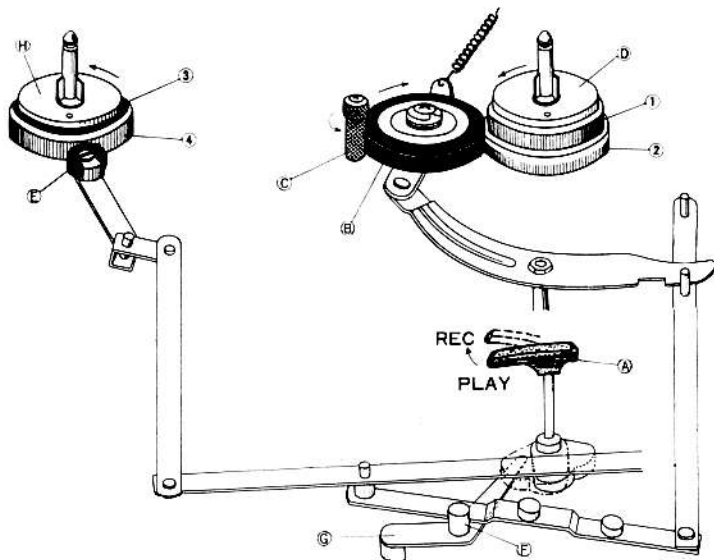

Fig. 2

Braked Rotation Slipping Rotation

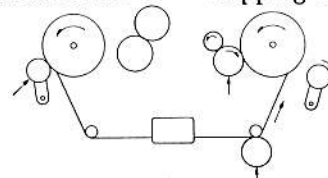

Fig. 3

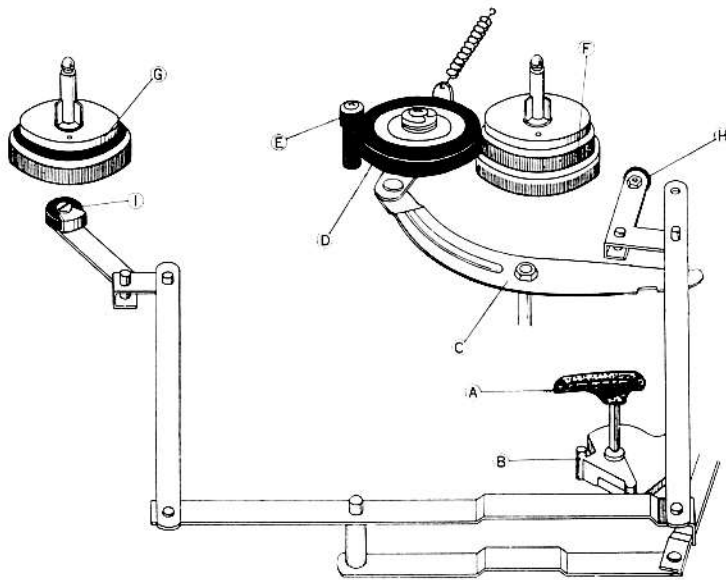

Fig. 4

FAST-FORWARD MECHANISM

Turn the *FAST FWD-REWIND knob (A)* to "FAST FWD" position, and the *cam (B)* under the knob pushes up the *Lever (C)*. The *Idler (D)* moves into the space between the *Plast'c Roller (F)* above the *Take-Up Reel Spindle* and the upper part of the rotating motor drive bushing to transmit the motor rotation to the take-up reel spindle. At the same time, *Brake Rollers (H)* and *(I)* come off the reel spindle to free the *Supply Reel Spindle (G)*, thereby allowing fast winding of the tape onto the take-up reel.

(See Figures 4 and 5)

Free Rotation High-Speed Rotation

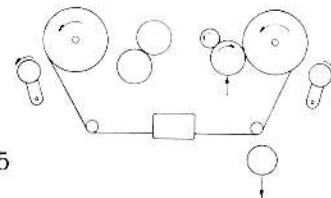

Fig. 5

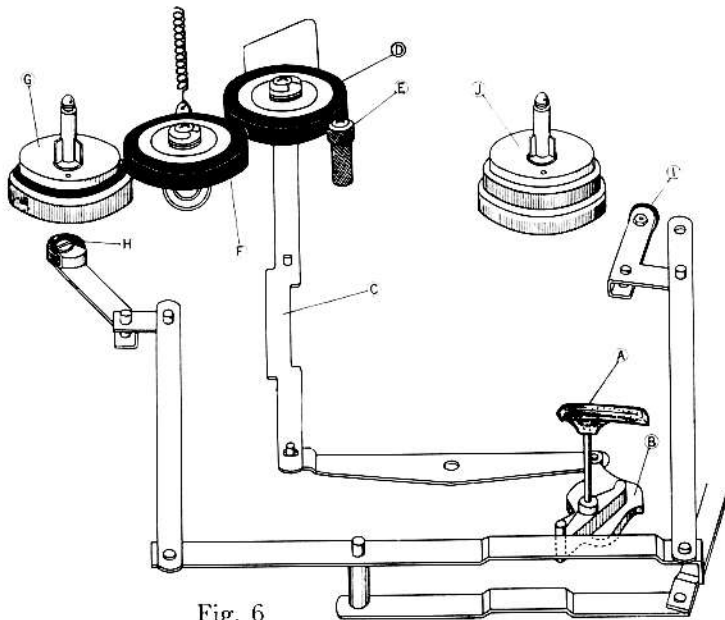

Fig. 6

REWIND MECHANISM

Turn the *FAST FWD-REWIND knob (A)* to "REWIND" position, and the *cam (B)* under the knob pushes the *Lever (C)* up. The *Idler (D)* moves into the space between the upper part of the rotating *Motor drive bushing (E)* and the *Intermediate Pulley (F)* to transmit the high-speed rotation of the motor through the intermediate pulley to the *Supply Reel Spindle (G)*. At the same time, *Brake Rollers (H)* and *(I)* come off the reel spindle to free the *take-up reel spindle (J)*, thereby rewinding the tape into the supply reel at a fast speed.

(See Figures 6 and 7)

High-Speed Rotation Free Rotation

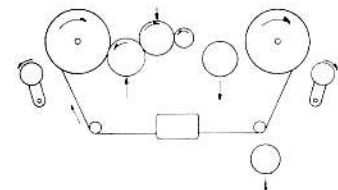

Fig. 7

| Modes of Operation | Pinch Roller | Take-up Idler Wheel | Rewind Idler Wheel | Take-up-side Brake | Supply side Brake |
|------------------------|--------------|---------------------|--------------------|--------------------|-------------------|
| (a) STOP | × | × | × | ○ | ○ |
| (b) FAST-FORWARD | × | ○ | × | × | × |
| (c) REWIND | × | × | ○ | × | ○ |
| (d) RECORDING PLAYBACK | ○ | ○ | × | × | × |

NOTES: ×-marks indicates "open" and ○-marks "engaged"

STOP CONTROL

Push the stop lever to "STOP" position, *Brake Rollers (A)* and *(B)* depress reel spindles to stop rotation of the reel spindles.

As the brake rubber depresses the plastic rollers under the reel spindles, no friction works on the tape itself.

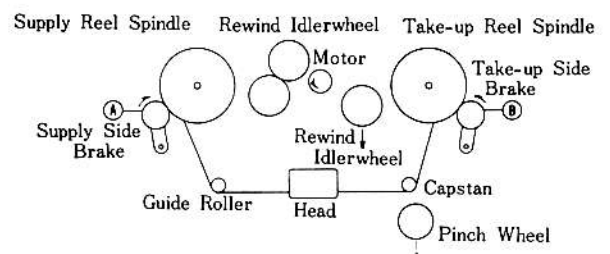

Fig. 8

RECORD/PLAYBACK CHANGING MECHANISM

By turning the RECORD/PLAYBACK KNOB (N) to the recording position, the LEVER (a) pulls the RECORDING LEVER (b) and (c), as illustrated in dotted line, then the RECORD/PLAYBACK CHANGE SWITCH (SW1) turns to recording position.

If the LEVER (c) does not turn properly, SW1 does not operate properly so may occur the abnormal oscillation and also can't record.

Then must adjust the LEVER (c) to proper position by loosening the SCREW (d).

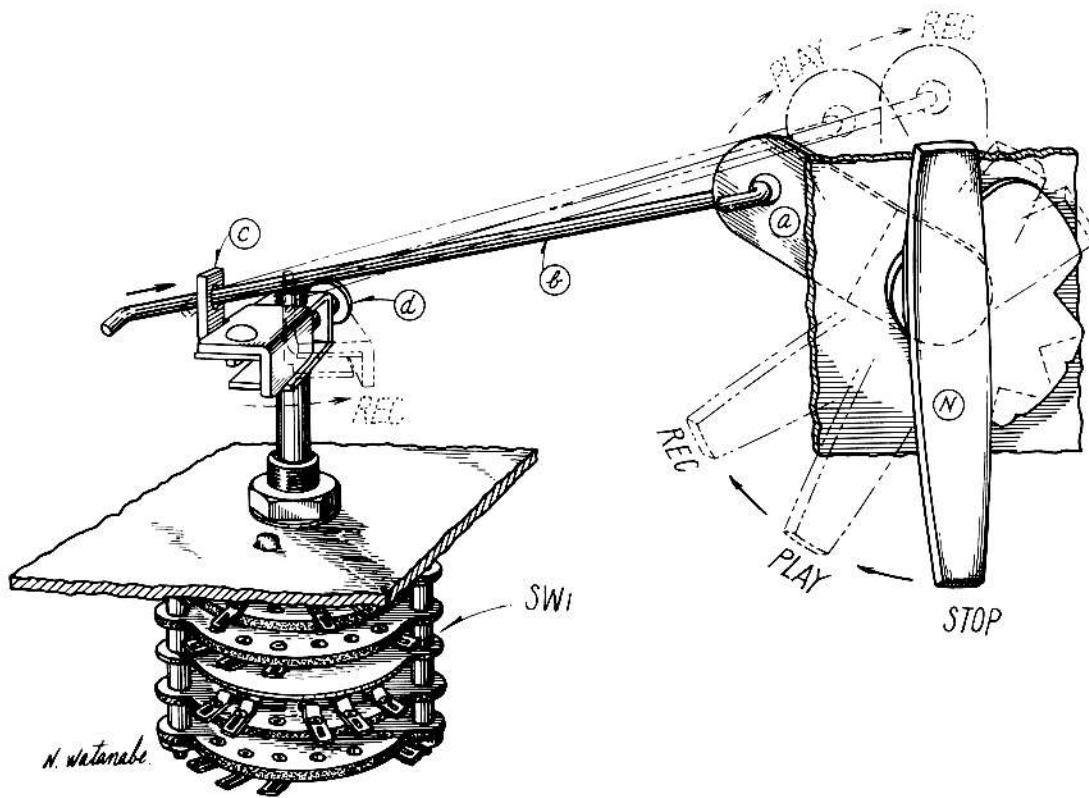

VI ADJUSTMENT OF TAPE TRANSPORT UNIT

1. ADJUSTMENT OF PINCH WHEEL

It is important that the pinch wheel shaft is kept in complete alignment with the capstan shaft. A proper pinch wheel pressure is between 1,000 and 1,150 grams when the unit is operated at the tape speed of 7-1/2 ips. Any deviation from this specification will result in wow and flutter. Check pinch wheel pressure by a spring scale and, if necessary, adjust the pinch wheel load spring.

2. ADJUSTMENT OF TAKE-UP IDLER WHEEL

The take-up idler wheel must be kept in complete alignment with the take-up reel shaft. When the unit is set in fast forward condition, the idler wheel will contact to the upper knurled wheel of the take-up reel shaft assembly, and it will contact to the lower knurled wheel during record or play mode. Adjust idler wheel load spring so that the idler wheel pressure is kept between 50 and 80 grams. The idler wheel rapidly wears if the pressure is excessive. The slippage occurs if the pressure is smaller than the specification.

3. ADJUSTMENT OF REWIND IDLER WHEEL

The rewind idler wheel must be kept in complete alignment with the rewind reel shaft. The amount of pressure to the knurled motor bushing should be maintained about 50 grams during rewind operation. Adjust both the idler load spring and rewind roller.

4. ADJUSTMENT OF INTERMEDIATE WHEEL

The intermediate wheel is located between the rewind idler wheel and the rubber ring which is used on the upper part of the supply reel shaft assembly. When the unit is set in rewind mode, it will contact to these parts simultaneously delivering torque of motor. An adequate pressure is 50 grams. Adjust the load spring of the intermediate wheel if the pressure is not sufficient.

5. ADJUSTMENT OF TAKE-UP REEL SHAFT ASSEMBLY

A felt clutch material is attached to the bottom side of the reel table base plate so that recording tape will not be stretched during fast forwarding operation due to excessive tension. To check the amount of friction of this part, place a 5-inch reel with recording tape wound by 60 m/m in diameter, and gently pull the end of tape upward using a spring scale. Adjust the conical spring so that the amount of tension at this part will be kept between 400 to 500 grams. Another felt clutch material is attached to the take-up drive wheel. It is to provide proper slipping operation during record or play mode. The procedure for checking friction of this part is same as the foregoing, and between 120 and 200 grams of friction will provide the best result. Adjust the star-shaped spring just under the take-up drive wheel. When the unit is set in rewind mode, the amount of friction of this part will greatly be reduced and will become 10 to 20 grams. Check to see whether this is satisfactory if not, readjust the star-shaped spring for Brake, and spring retainer washed accordingly. (See figure 11 (a) at left)

6. ADJUSTMENT OF SUPPLY REEL SHAFT ASSEMBLY

A felt clutch material is used between the lower side of the reel table base plate and the rewind rubber ring to protect recording tape from an excessive tension while rewinding operation. To check the amount of friction of this part, place onto the supply reel table a 5-inch reel with recording tape wound by 60m/m in diameter and gently pull the end of tape upward by a spring scale. Adjust the conical spring so that the amount of tension is kept between 400 and 500grams. Another felt clutch is attached to the rewind drive wheel to provide proper slipping operation during record or play mode. The procedure for checking friction of this part is same as the foregoing, and between 80 and 120 grams of friction will give the best result. When the unit is set in fast forward mode, the amount of friction will greatly be reduced and will become 10 to 20 grams.

Check to see whether this is proper, if not, readjust coil spring and spring retainer washer.

(See figure 11 (b) at left)

7. ADJUSTMENT OF TAPE HEAD

A vertical azimuth alignment of tape head is the only adjustment that can be made at the field of service. To align tape head, play 8,000 cycles recorded on an Ampex standard alignment tape. Rotate the azimuth alignment screw until a maximum playback level through the small hole which is positioned on the shield cover of the tape head assembly.

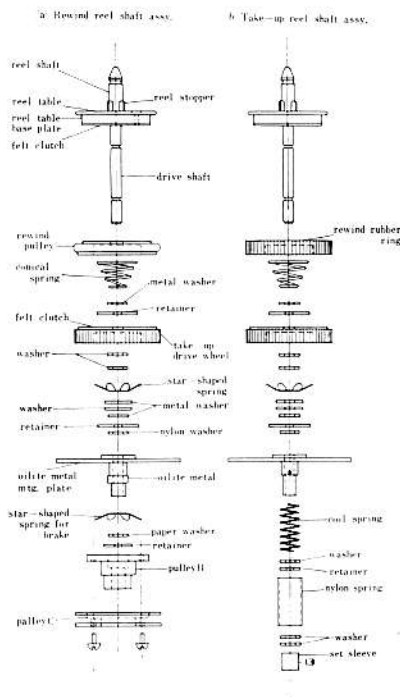

Fig. 11

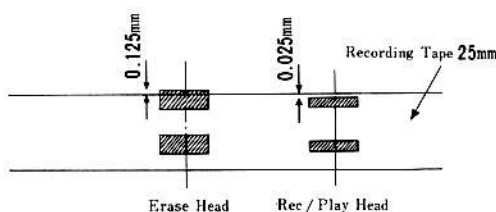

Fig. 12

VII ADJUSTMENT OF AMPLIFIER

1. ADJUSTMENT OF RECORDING BIAS FREQUENCY

Recording/erasing bias frequency was set at 90 KC plus or minus 5 KC before shipment. It is decided by inductance of the oscillator coil (part # 17-L₁) and its resonant capacitor (part # C-17). To measure recording bias frequency, insert a 10 or 100 ohm resistor in series to the record/play head and connect vertical input terminals of an oscilloscope as shown in the Fig. 13. Another testing instrument to be prepared is an audio frequency oscillator and its output should be connected to horizontal input terminals of the oscilloscope. Vary frequency generated by the audio frequency oscillator around 90 KC, and set the oscillator at the point where a desirous figure appears on the oscilloscope. The recording bias frequency now corresponds to the reading of the oscillator. Check oscillator coil, C-17 and bias head if the recording bias frequency measured is not within 90 KC \pm 5 KC.

2. ADJUSTMENT OF RECORDING BIAS VOLTAGE

A proper recording bias voltage is 45 volts \pm 3 volts A.C. and is adjusted by C16. To measure recording bias voltage, connect a V.T.V.M. (Vacuum Tube Volt Meter) to the record/play head as shown in the Fig. 14.

Check C16 (included AK 13) and record/play head if the recording bias voltage measured does not meet to the above-mentioned specification.

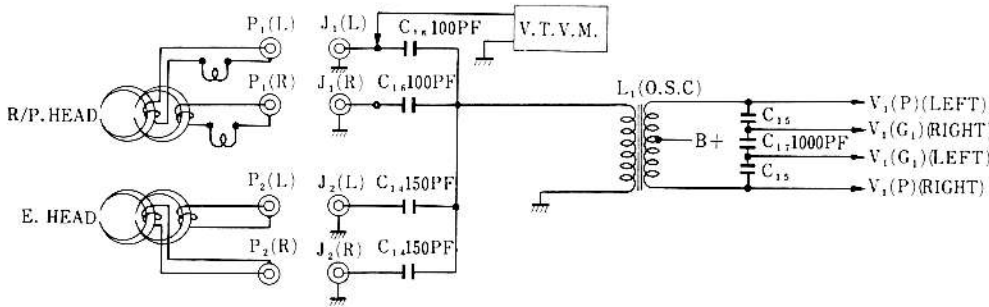

Fig. 14

3. ADJUSTMENT OF ERASING BIAS VOLTAGE

A proper erasing bias voltage is 65 volts \pm 5 volts A.C. and is adjusted by C14. To measure erasing bias voltage, connect a V.T.V.M. to the erase head as shown in the Fig. 15.

Check C14 and erase head if the erasing bias voltage measured does not meet to the above-mentioned specification.

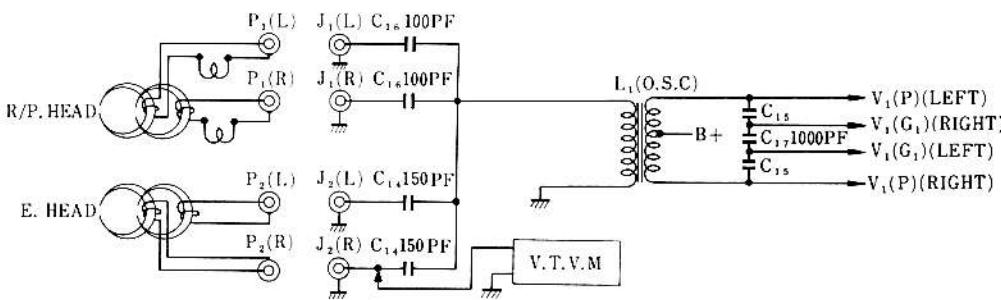

Fig. 15

4. ADJUSTMENT OF RECORDING LEVEL

A basic recording level, referred to as "0 VU", set at the point where current of 30 μ A \pm 10 % flows to the recording head at 1,000 cycles. The VU meter indicates 0 VU \pm 2 VU when a signal of -55 db \pm 5 db at the microphone jack or -40 db \pm 5 db at the line input jack when the volume control set at its maximum.

Adjustment of recording level can be accomplished by varying sensitivity of VU meter, however, it is not necessary to make in a field of service as all VU meters have correctly been calibrated at factory before shipment. (See Fig. 16 for details.)

NOTE: Make sure to stop oscillation by disconnecting the oscillator coil # 17-L₁ at the points marked "P" and "G" prior to measurement of recording level.

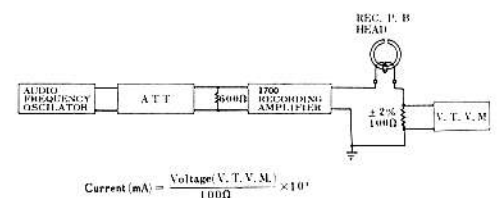

Fig. 16

VIII MAINTENANCE PROCEDURES

1. LUBRICATION INSTRUCTION

For maximum service life and optimum performance, lubricate the parts identified below after each 500 hours of operation. Use only light machine oil of good quality

| | |
|--|---------|
| Motor | 3 drops |
| Drive Capstan Shaft | 2 drops |
| Rewind Idler Wheel Bearing and Wind take-up Idler Bearing. | 1 drop |
| Intermediate Idler Bearing | 1 drop |
| Pinch Wheel Bearing | 2 drops |
| Take-up and Supply Reel Shaft Bearing & | 2 drops |
| Also apply a liberal film of light machine grease to each roller surface of all levers and cams. | |

CAUTION: DO NOT OVER-LUBRICATE. WIPE OFF EXCESS OIL BY A COTTON SWAB SOAKED IN ALCOHOL. OTHERWISE, THE OVER-FLOWED LUBRICANT MAY BE SCATTERED DURING OPERATION. THE RUBBER COMPONENT PARTS WILL BE DETERIORATED.

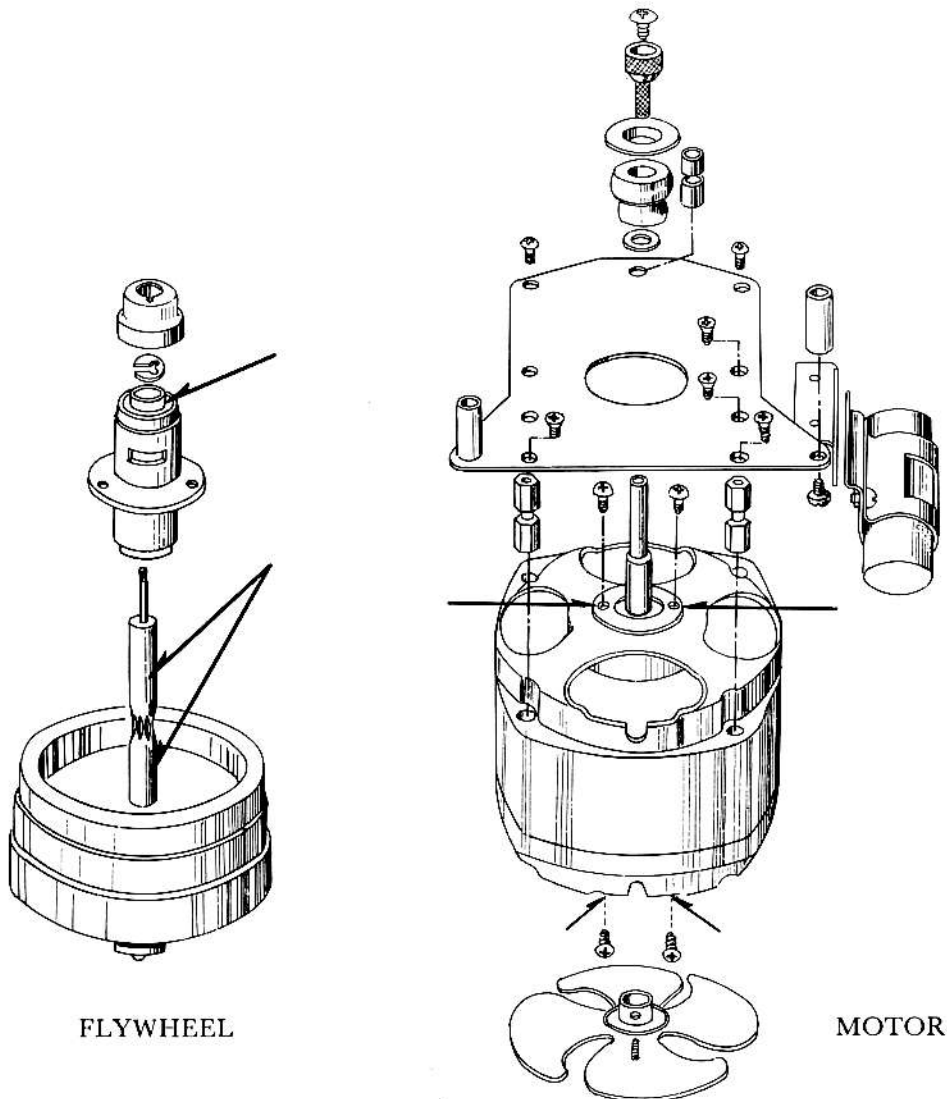

Fig. 17

2. CLEANING TAPE HEADS AND OTHER PARTS

Wipe surface of tape heads, guide roller bearing, capstan bushing and pinch wheel periodically with a soft cloth soaked in alcohol or carbon-tet.

IX LIST OF REPLACEMENT PARTS

| Parts No. | Nomenclature |
|-------------------|--|
| TOP PANEL | |
| 171-001 | Deck Panel |
| 002 | Head Cover |
| 003 | Frame, Head Cover |
| 004 | Capstan Rest |
| 004a | Capstan Holder |
| 005a | Table A, Tape Guide |
| 005b | Washer |
| 005c | Table, Washer |
| 005d | Washer |
| 005e | Bearing (635JZZ) |
| 005f | Washer |
| 005g | Table, Washer |
| 005h | Washer |
| 005i | Table B, Tape Guide |
| 005j | Prop, Tape Guide |
| 006 | Plate |
| DECK FRAME | |
| 172-001 | Deck Frame |
| 002 | Head Assembly, Complete |
| 002a | Erase Head |
| 002b | Record/Playback Head |
| 002c | Screw Flat Mould 4×8 |
| 002d | Prop A, Head |
| 002e | Prop C, Head |
| 002f | Screw Flat Mould 4×8 |
| 002g | Screw Flat 4×8 |
| 003 | Index Counter, Complete |
| 003a | Pulley, Counter |
| 003b | Belt, Counter |
| 003c | Screw, Without Head 4×7.5 |
| 004 | Supply Reel Assembly |
| 004a | Screw Flat 3×6 |
| 004b | Plate, Reel Table |
| 004c | Reel Shaft A, Supply Reel |
| 004d | Rubber Ring |
| 004e | Rewind Pulley |
| 004f | Spring G, Left |
| 004g | Washer |
| 004h | Washer Pin, Large |
| 004i | Felt Washer |
| 004j | Take-up Roller, C |
| 004k | Holder, Reel Shaft (Star Type Spring) |
| 004l | Washer |
| 004m | Washer |
| 004n | Washer |
| 004o | Washer Pin, large |
| 004p | Washer |
| 004q | Metal Fitting A, Reel Table |
| 004r | Holder, Reel Shaft (Star Type Spring) |
| 004s | Washer |

| Parts No. | Nomenclature |
|-----------|---|
| 172-004t | Washer Pin |
| 004u | Pulley, Reel Shaft |
| 004v | Screw, without Head |
| 005 | Take-up Reel Assembly |
| 005a | Reel Shaft A, Take-up Reel |
| 005b | Felt Washer |
| 005c | Take-up Roller, A |
| 005d | Spring G, Right |
| 005e | Deer Skin |
| 005f | Take-up Roller, B |
| 005g | Holder, Reel Shaft (Star Type Spring) |
| 005h | Metal Fitting B, Reel Table |
| 005i | Spring, F3 |
| 005j | Washer |
| 005k | Washer |
| 005l | Washer Pin |
| 005m | Nylon Spring |
| 006a | AS Lever, Complete |
| 006b | Plate, AS Lever, with AS Lever Prop |
| 006c | Screw Bind 3×5 |
| 006d | Washer Pin |
| 006e | 3 mm Ground Lug |
| 007a | Instant Stop Lever, A |
| 007b | Spring, Instant Stop Lever |
| 007c | Stopper, Instant Stop Lever |
| 007d | Screw Bind 3×5 |
| 007e | Holder B, Instant Stop Lever |
| 007f | Screw Flat Mould 4×8 |
| 008a | Recording Safety Button |
| 008b | Cam Stopper |
| 008c | Fiber, Cam Stopper |
| 008d | Insulator Plate, Cam Stopper |
| 008e | Screw Flat Mould 4×8 |
| 009a | Pinch Wheel |
| 009b | Metal Cap, Pinch Wheel |
| 009c | Screw |
| 009d | Lever, Pinch Wheel |
| 009e | Shaft C, Pinch Wheel |
| 009f | 4 mm Nut |
| 009g | Shaft A, Cam Roller |
| 009h | Cam Roller B |
| 009i | Shaft, Pinch Wheel Lever |
| 010a | Lever, Take-up Brake |
| 010b | Take-up Brake Roller |
| 010c | Screw, Brake Roller |
| 010d | 3 mm Nut |
| 010e | Shaft, Take-up Brake Lever |
| 010f | Washer Pin |
| 011a | Lever, Supply Brake |
| 011b | Supply Brake Roller |
| 011c | Screw, Brake Roller |
| 011d | 3 mm Nut |
| 011e | Shaft, Supply Brake Lever |
| 011f | Washer Pin |
| 012a | Switch, Automatic Shut-off (6P Slide Switch) |

| Parts No. | Nomenclature |
|-----------|--|
| 172-012b | Plate, Automatic Shut-off Switch |
| 012c | Screw Semi-Cubic 3×5 |
| 013a | Micro Switch M-8-3 |
| 013b | Holder, Switch |
| 013c | Screw Semi-Cubic 3×5 |
| 013d | Screw Flat Mould 3×15 |
| 013e | Washer |
| 014a | Switch, Speed Change (6P Slide Switch NC) |
| 014b | Plate, Speed Change Switch |
| 014c | Screw Flat Mould 4×10 |
| 014d | Cord Support |
| 015a | Idler Wheel |
| 015b | Washer |
| 015c | Washer Pin |
| 016a | Internal Wheel |
| 016b | Washer |
| 016c | Washer Pin |
| 017a | Lever, A |
| 017b | Shaft, Lever A |
| 018a | Lever, B |
| 018b | Cam Roller, A |
| 018c | Cam Roller, B |
| 018d | Washer Pin |
| 019a | Lever, C3 |
| 019b | Washer Pin |
| 019c | Washer |
| 020 | Lever, D |
| 021 | Lever, E-2 |
| 022a | Lever, FA |
| 022b | Cam Roller, A |
| 022c | Washer Pin |
| 023a | Lever, G |
| 023b | Holder, Lever G Metal |
| 023c | Stopper, Lever G |
| 023d | Lever G Metal |
| 024a | Lever, H-C |
| 024b | Idler Shaft, B |
| 025a | Lever K |
| 025b | Screw A |
| 026a | Lever F, for Motor |
| 026b | Fiber Washer |
| 026c | Washer Pin |
| 027 | Prop, Panel |
| 028 | Spring Pin, B |
| 029 | Spring Holder |
| 030a | Hum Bucking Coil, for Left Channel |

| Parts No. | Nomenclature |
|-----------|---|
| 172-030b | Hum Bucking Coil, for Right Channel |
| 030c | Holder, Hum Bucking Coil |
| 030d | Screw Semi-Cubic 3×22 |
| 032a | Lever, Belt Change |
| 032b | Metal Fitting, Belt Change Lever |
| 032c | Spring, Belt Change Lever |
| 033a | Table, Lifter Pin |
| 033b | Lifter Pin |
| 033c | Spork, for Lifter |
| 033d | Cam A, Head Lifter |
| 033e | Cam B, Head Lifter |
| 034a | Spring A |
| 034b | Spring, UN-D |
| 034c | Spring, D |
| 034d | Spring, E |
| 034e | Spring, Idler |
| 034f | New Spring D |
| 034g | Torsion Spring |
| 034h | Spring, B |
| 034i | Spring, Belt Change |
| 034j | Spring B, Belt Change |
| 173-001 | Motor, Complete |
| 001a | Screw Flat Mould 3×15 |
| 001b | Stepped Pulley |
| 001c | Belt Holder |
| 001d | Motor Pulley |
| 001e | Oil Retainer |
| 001f | Motor Holder |
| 001g | Motor |
| 001h | Motor Fan, D |
| 001i | MP Condenser 2uf (260VAC) |
| 001j | Holder, Motor Condenser |
| 001k | Prop, Motor 8×22.5 |
| 001l | Prop, Motor 8×21.5 |
| 001m | Screw |
| 001n | Screw |
| 001o | Screw Flat Mould 4×50 |
| 001p | Screw, without Head 4×5 |
| 001q | Screw Bind 3×5 |
| 001r | Hexagonal Nut |
| 174-001 | Flywheel, Complete |
| 001a | Capstan |
| 001b | Main Metal Case |
| 001c | Flywheel |
| 001d | 4 mm Ball Bearing |
| 001e | Plate C, Flywheel |
| 001f | Washer |
| 001g | Washer |
| 001h | Wing Nut |
| 001i | Screw, Flywheel adjust |
| 001j | Prop B, Flywheel |
| 001k | Prop C, Flywheel |
| 001l | Drive Belt |
| 175-001 | Switch Block |
| 001a | Knob, Record/Playback & Rewind Fast Forward |
| 001b | Screw |

| Parts No. | Nomenclature |
|------------------|--------------------------------|
| 175-001c | Cam A |
| 001d | Cam B |
| 001e | 8 mm Ball Bearing |
| 001f | Switch Table, A |
| 001g | Lever, I |
| 001h | Fast/Forward Rewind Shaft |
| 001i | RC/Playback Rewind Shaft |
| 001j | Pin |
| 001k | Plate, Cam |
| 001l | Spring, K |
| 001m | Cam, C |
| 001n | Switch Table, B |
| 001o | Record/Playback Conversion Pin |
| 001p | Spork Cam |
| 001q | Washer |
| 001r | Prop |
| 001s | Screw Bind 3×5 |
| 001t | Screw |
| 001u | Screw |
| 001v | Screw |
| 001w | Nut |
| CASE | |
| 176-001 | Cabinet, Complete |
| 002a | Table, Rubber Foot |
| 002b | Rubber Foot |
| 002c | Screw Semi-Cubic 3×18 |
| 003a | Ventilator (Panel Escucheon) |
| 003b | Screw Truss 6×12 |
| 004a | Ventilator, A |
| 004b | Screw Truss 6×12 |
| 005a | Ventilator, B |
| 005b | Screw Truss 6×12 |
| 006 | Prop C, Reel |
| 007 | Russ Plate, Speaker |
| 008a | Chassis A, Speaker |
| 008b | Chassis B, Speaker |
| 009a | Speaker 5×7" |
| 009b | Screw Flat Mould 4×12 |
| 010 | Speed Nut |
| AMPLIFIER | |
| 17-A1 | Amp. Chassis |
| A2 | 1700 Name Plate |
| A3 | Amplifier Knob, A (Tone) |
| A4 | Amplifier Knob, B (Volume) |
| A5 | Angle, changing Voltage |
| A6a | Screw, without Head 4×6.5 |
| A6b | Screw, without Head 4×11.5 |
| A6c | Screw, Semi-Cubic 4×8 |
| 17-AK13 | C.R. Compound Body |
| AK14 | C.R. Compound Body |

| Parts No. | Nomenclature |
|-----------|--|
| 17-C2 | Mica Condenser 101J 500 WV |
| C3 | Ceramic Condenser 0.02 P 500 WV |
| C4 | Ceramic Condenser 0.02 P 500 WV |
| C5 | Oil Paper Condenser 0.05 M 400 WV |
| C6 | Ceramic Condenser 0.02 P 500 WV |
| C7 | Ceramic Condenser 0.01 P 500 WV |
| C8 | Ceramic Condenser 0.02 P 500 WV |
| C9 | Ceramic Condenser 0.02 P 500 WV |
| C10 | Ceramic Condenser 0.002 P 1 KWV |
| C11 | Ceramic Condenser 0.02 P 500 WV |
| C12 | Tubular Type Electrolytic Condenser 50 µf 25 WV |
| C14 | Mica Condenser 101J 500 WV |
| C16 | Mica Condenser 151J 500 WV |
| C18 | Mica Condenser 500J 500 WV |
| C20a-b | Lug Terminal Type Electrolytic Condenser 40+40 µf 350 WV |
| C21 | Tubular Type Electrolytic Condenser 40 µf 350 WV |
| C22 | Tubular Type Electrolytic Condenser 20 µf 300 WV |
| C23 | Tubular Type Electrolytic Condenser 10 µf 15 WV |
| C24 | Tubular Type Electrolytic Condenser 10 µf 10 WV |
| 17-R1 | Fixed Resistor 1/4 P 500 KΩ |
| R2 | Fixed Resistor 1/4 P 3 KΩ |
| R3 | Fixed Resistor 1/4 P 2.2 MΩ |
| R4 | Fixed Resistor 1/2 P 250 KΩ |
| R5 | Fixed Resistor 1/2 P 100 KΩ |
| R6 | Fixed Resistor 1/4 P 2 KΩ |
| R7 | Fixed Resistor 1/2 P 250 KΩ |
| R8 | Fixed Resistor 1/4 P 500 KΩ |
| R9 | Fixed Resistor 1/4 P 20 KΩ |
| R10 | Fixed Resistor 1/4 P 1 MΩ |
| R11 | Flexible Resistor 1 W 8 Ω |
| R12 | Fixed Resistor 1/4 P 200 Ω |
| R13 | Fixed Resistor 1/4 P 10 KΩ |
| R14 | Fixed Resistor 1/4 P 500 KΩ |
| R15 | Fixed Resistor 1/4 P 500 KΩ |
| R16 | Fixed Resistor 1/4 P 1 KΩ |
| R18 | Wired Resistor 10WL 470 Ω |
| R19 | Wired Resistor 10WL 470 Ω |
| R20 | Fixed Resistor 1L 10 KΩ |
| R21 | Wired Resistor 3WL 180 Ω |
| R22 | Flexible Wired Resistor 3W 8 Ω |
| R23 | Fixed Resistor 1/4 P 10 KΩ |
| R24 | Fixed Resistor 1/4 P 500 Ω |
| 17-VR1-2 | Variable Resistor 1 M(A) 50K(A) Double VR |
| VR3 | Wired Variable Resistor 1/2 W 100 Ω |
| VR4 | Wired Variable Resistor 1/2 W 100 Ω |

| Parts No. | Nomenclature |
|-----------|--|
| 17-SD1 | Silicone Diode SM-150D |
| SD2 | Silicone Diode SM-150D |
| 17-F1 | Fuse Post |
| F2 | Fuse, 2 A |
| 17-J1 | 2 Connective Pin Jack |
| J2 | 2 Connective Pin Jack |
| J3-5 | 2 Connective Pin Jack |
| J4 | 2 Pole E Jack |
| J6 | 2 Pole E Jack |
| J7 | 3 Pole E Jack |
| 17-T1 | Power Transformer |
| T2 | Out-put Transformer |
| 17-L1 | Oscillator Coil |
| L2 | Choke Transformer |
| 17-M1 | VU Meter |
| 17-PL1 | Pilot Lamp |
| PL2 | Lamp Socket, Swan Type |
| 17-SW1 | Rotary Switch (Record/ Playback Conversion) |

| Parts No. | Nomenclature |
|-----------|--|
| 17-SW2 | 6P Slide Switch, with White Knob (Meter Conversion) |
| SW3 | 6P Slide Switch, with White Knob (Speaker ON/OFF) |
| SW4 | 8P Slide Switch (Track Selector) |
| SW5 | Toggle Switch (Power ON/OFF) |
| SW6 | 6P Slide Switch, with Black Knob (50/60 cycle change) |
| 17-TB1 | 52L2 Lug Plate |
| TB2 | 42L1 Lug Plate |
| TB3 | 41L2 Lug Plate |
| TB4 | 31L1 Lug Plate |
| TB5 | 2L1 Lug Plate |
| 17-V1a | Vacuum Tube 12AT7 |
| V1b | Vacuum Tube 12AT7 |
| V2a | Vacuum Tube 6BM8 |
| V2b | Vacuum Tube 6BM8 |
| 17-VS1 | Vacuum Tube Socket, 9P mould type |
| VS2 | Vacuum Tube Socket, 9P mould type |

| Parts No. | Nomenclature |
|-----------|--------------------------------------|
| 17-VS3 | Vacuum Tube Socket, 9P mould type |
| VS4 | Vacuum Tube Socket, 9P mould type |
| 17-Z1 | Transformer Angle, Left |
| Z2 | Transformer Angle, Right |
| Z3 | Name Plate, Cycle Change |
| Z4 | Socket, change Voltage |
| Z5 | Hexagonal Prop, Selector |
| Z6 | Name Plate, change AC |
| Z7 | 3 mm Nut, special |
| Z8 | Cord Support |
| Z9 | Rubber Bush, AC Cord |
| Z10 | AC Cord |
| Z11 | Plate A, Jack |
| Z12 | Plate B, Jack |
| Z13a | Clamp Pin, for 6BQ5 |
| Z13b | Clamp Pin, for 12AT7 |
| Z14a | Screw Semi-Cubic 4×8 |
| Z14b | Screw Semi-Cubic 3×6 |
| Z14c | Screw Flat Mould 4×16 |
| Z14d | Screw Semi-Cubic 3×6 |

X EXPLODED VIEW OF COMPONENT PARTS

Front Panel

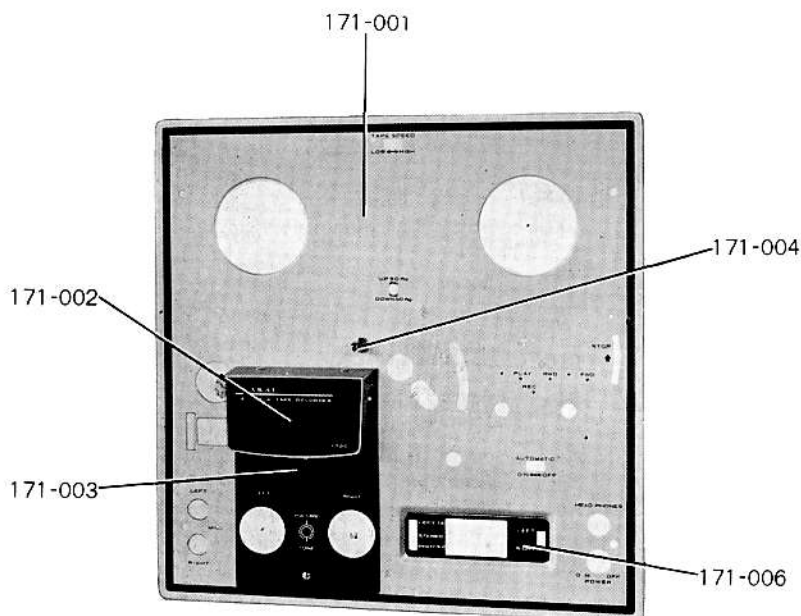

Amplifier I

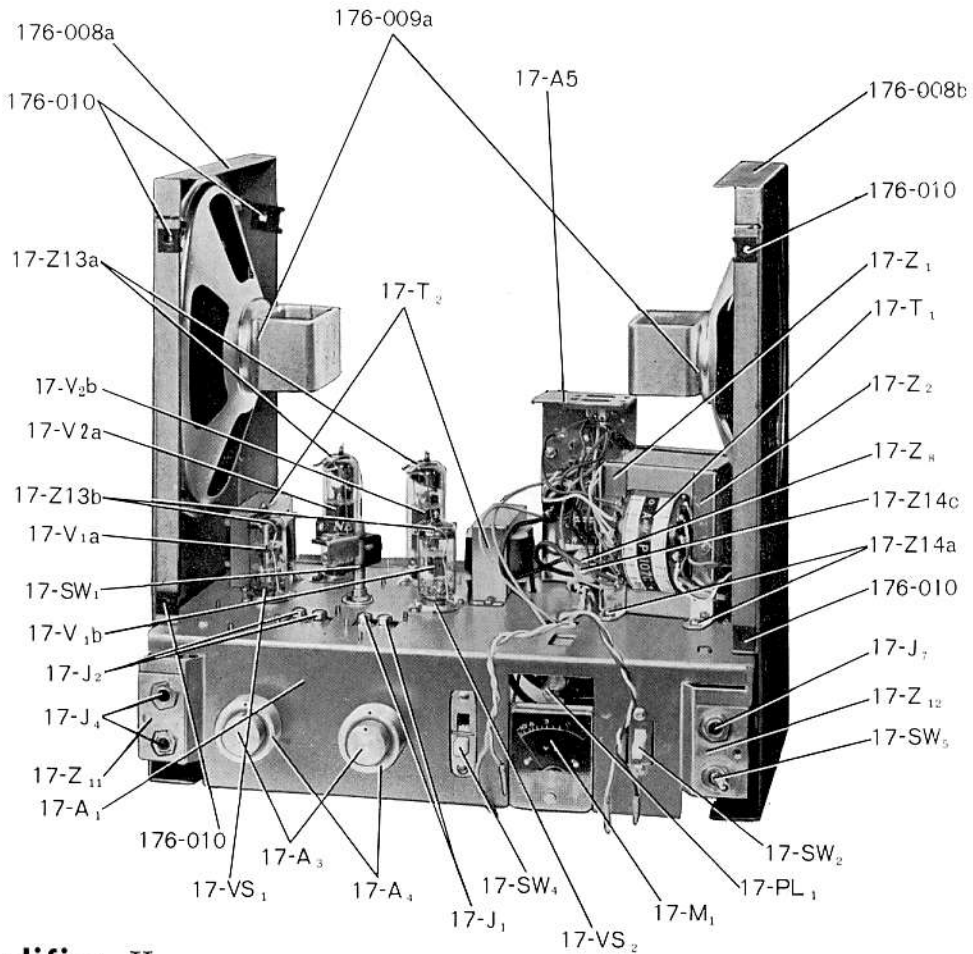

Amplifier II

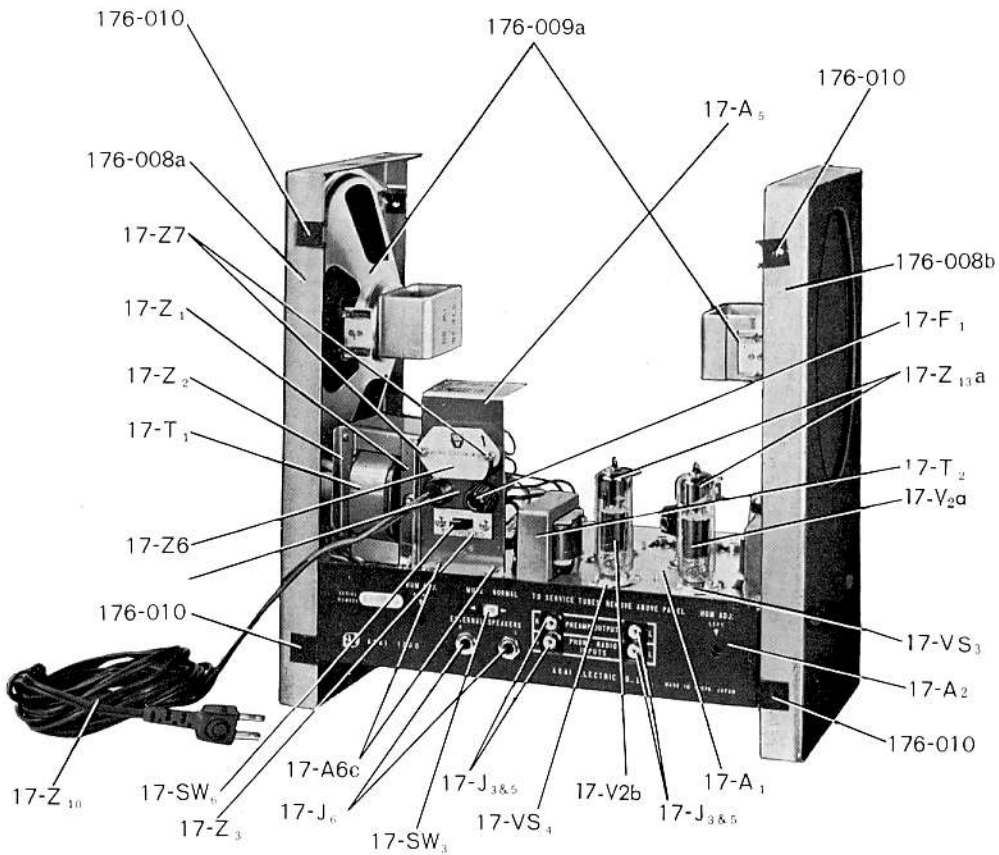

Amplifier III

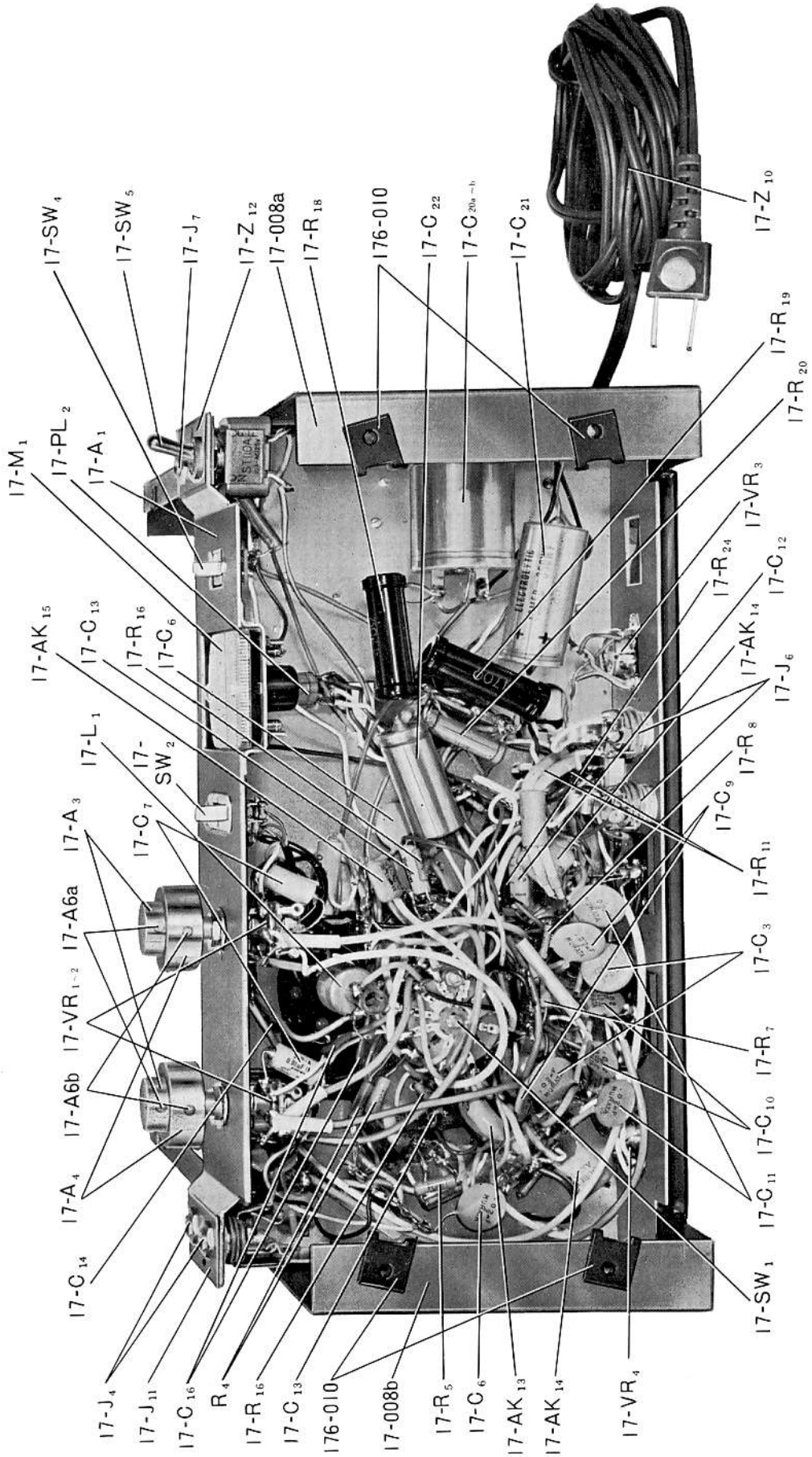

176-001

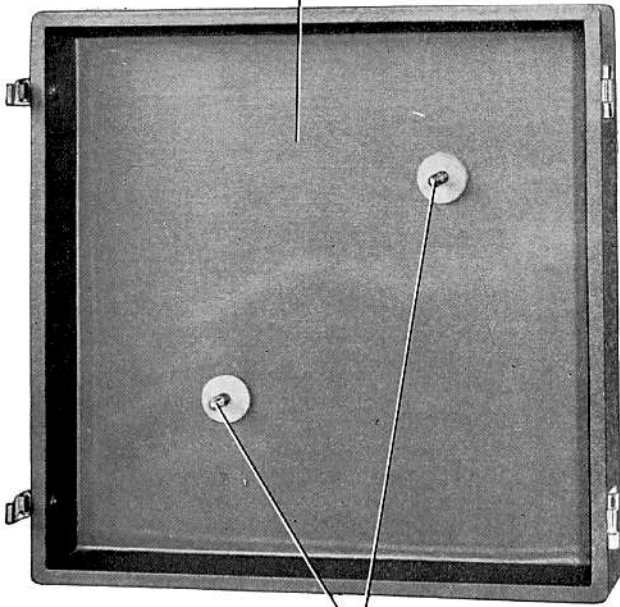

176-006

Case I

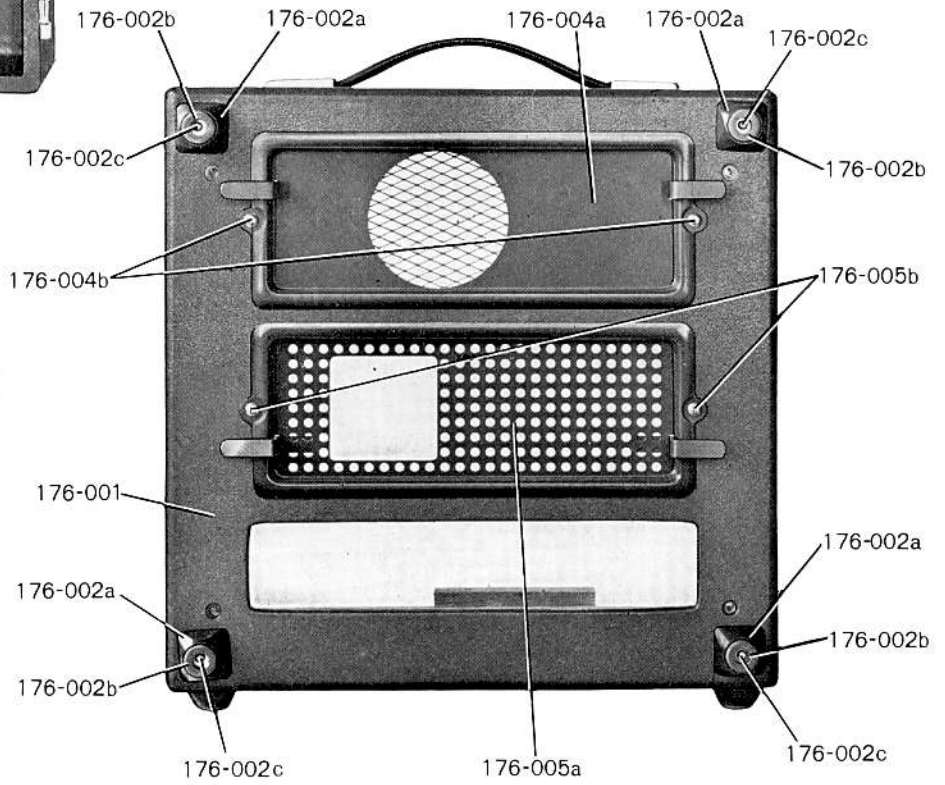

Case II

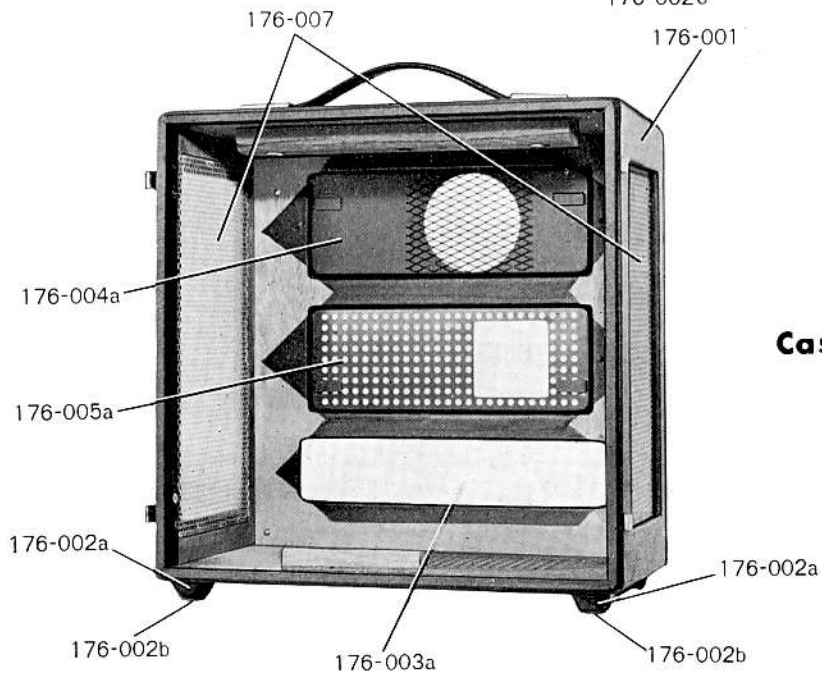

Case III

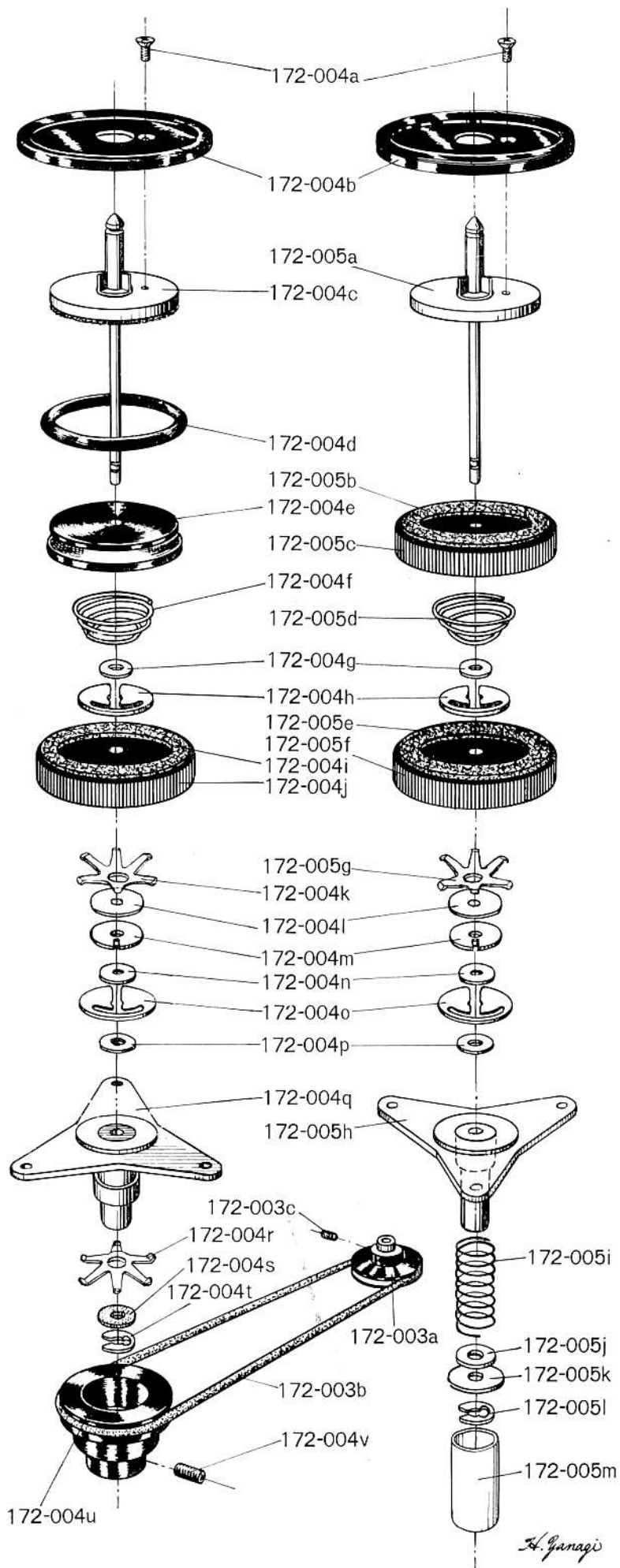

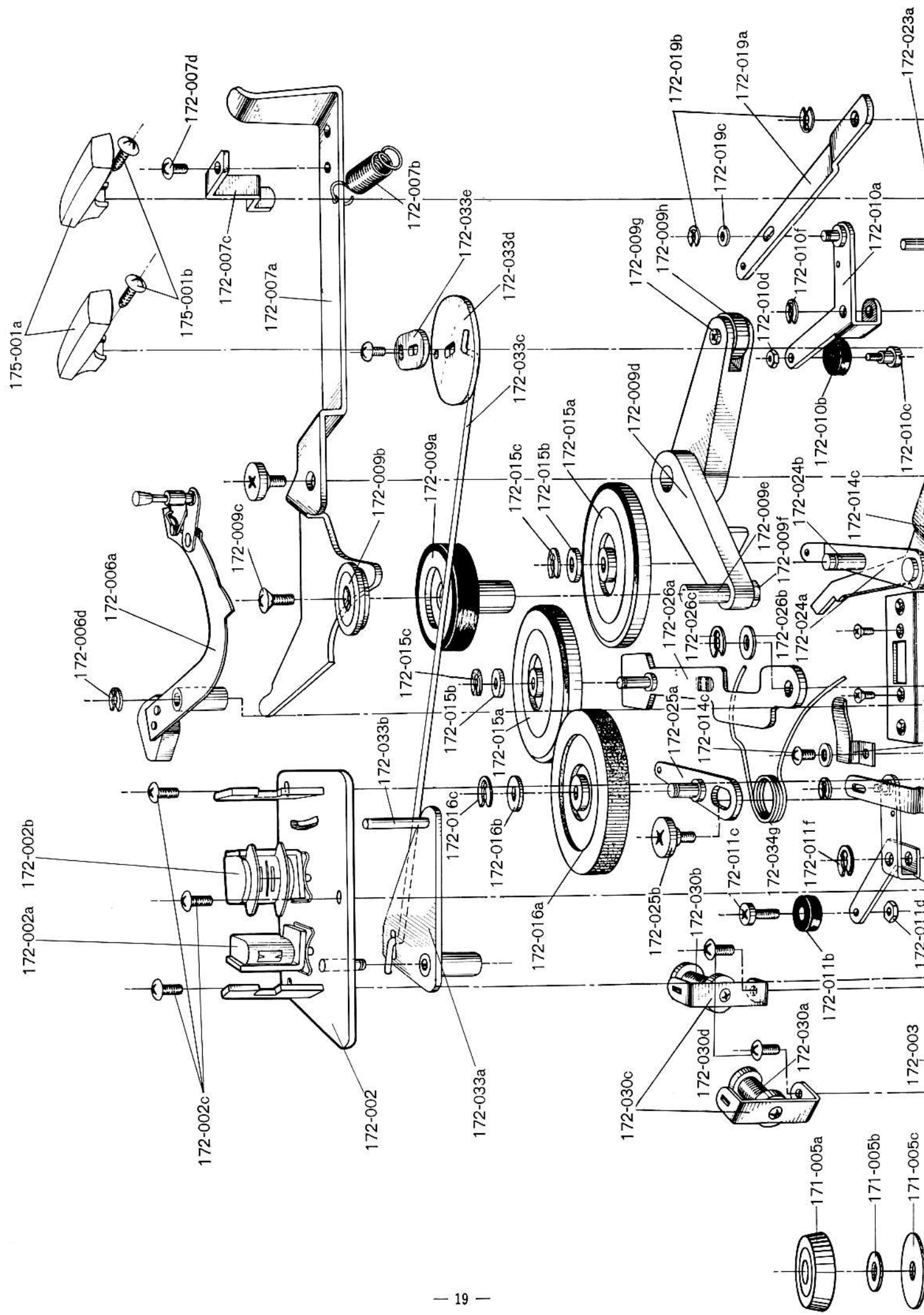

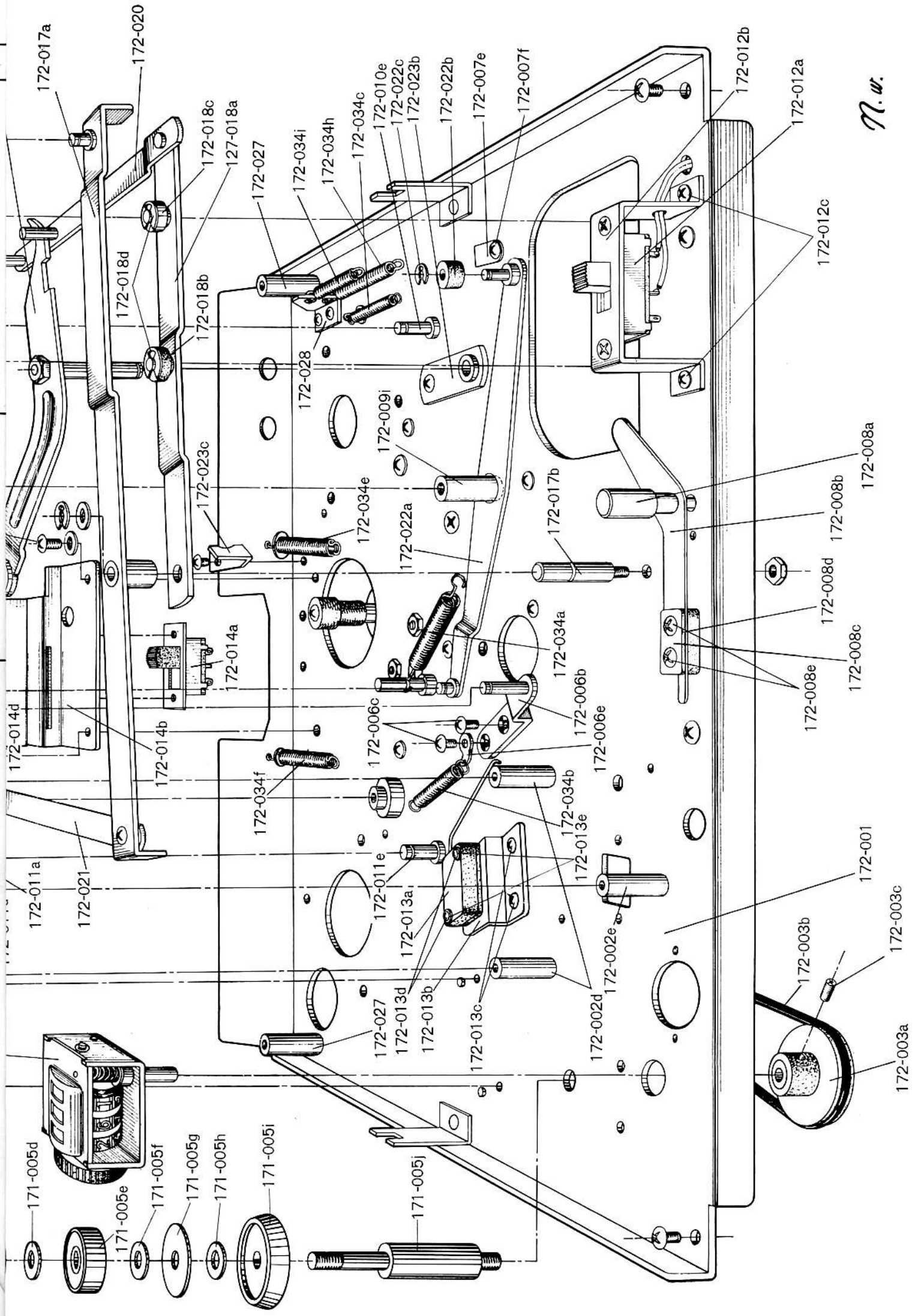

N. w.

172-001

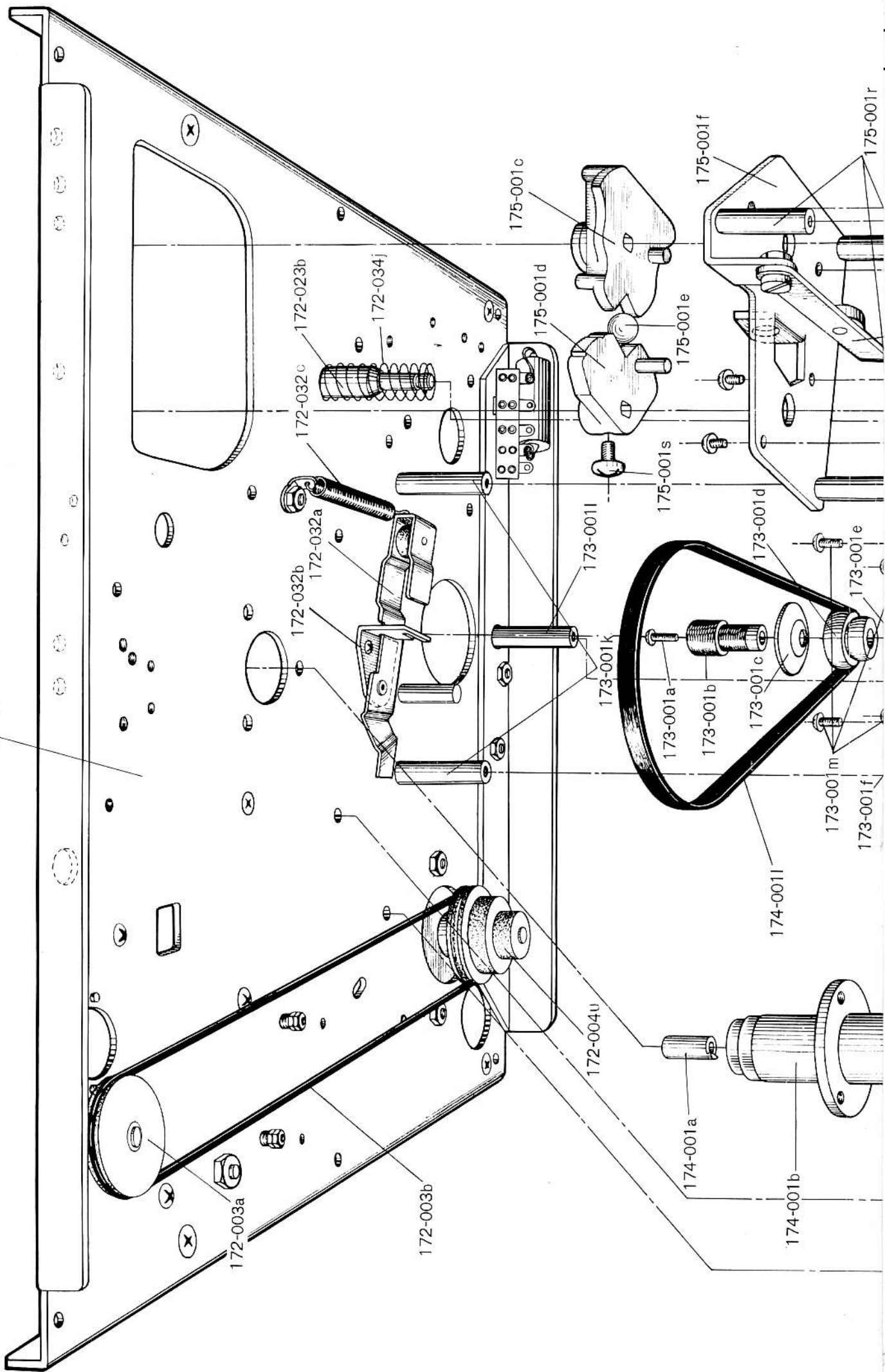

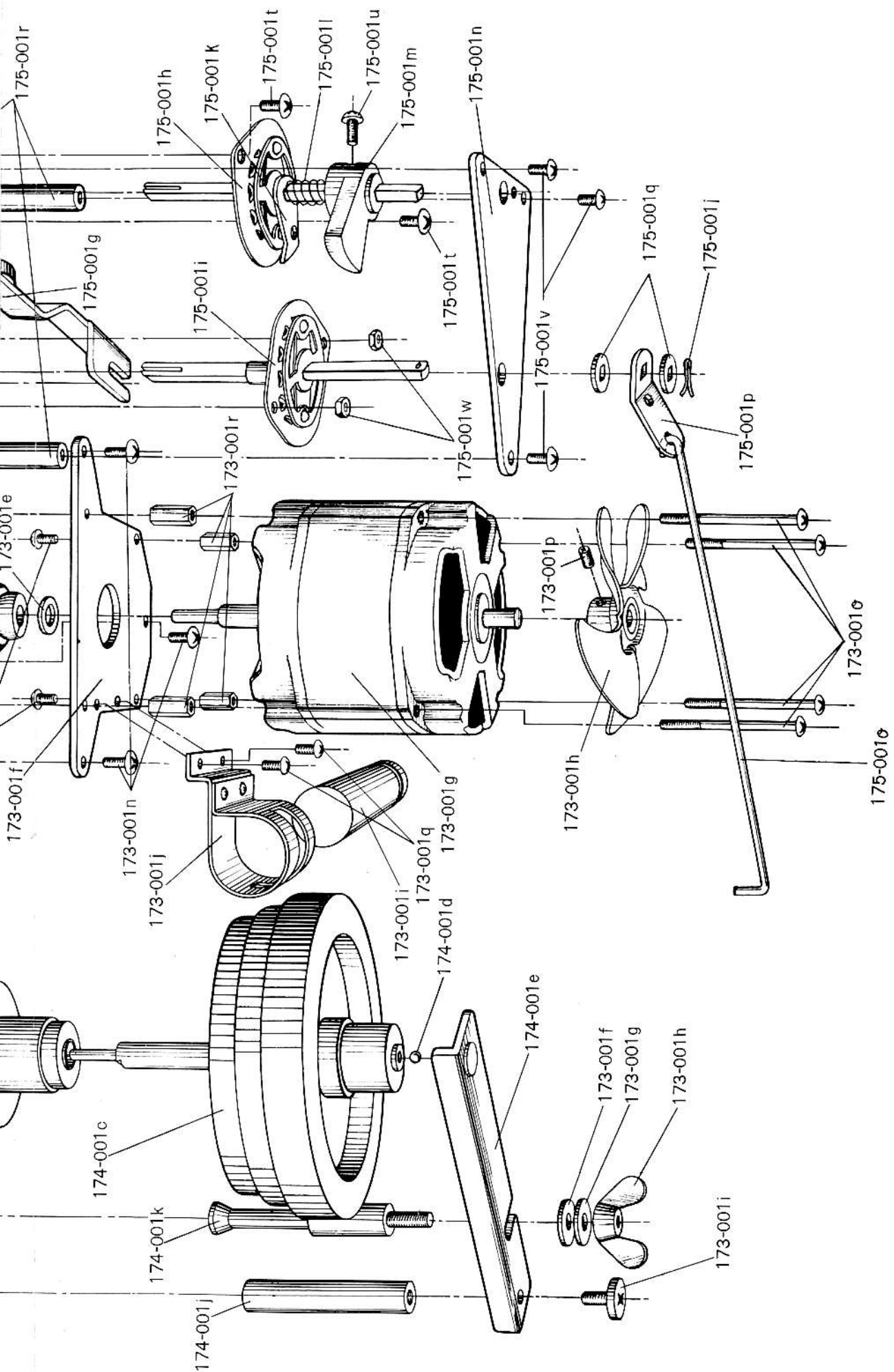

XI TROUBLE SHOOTING CHART FOR MODEL 1700

SECTION "A" TROUBLES WITH AMPLIFIER

I. Playback problems. (Unit set in play position.)

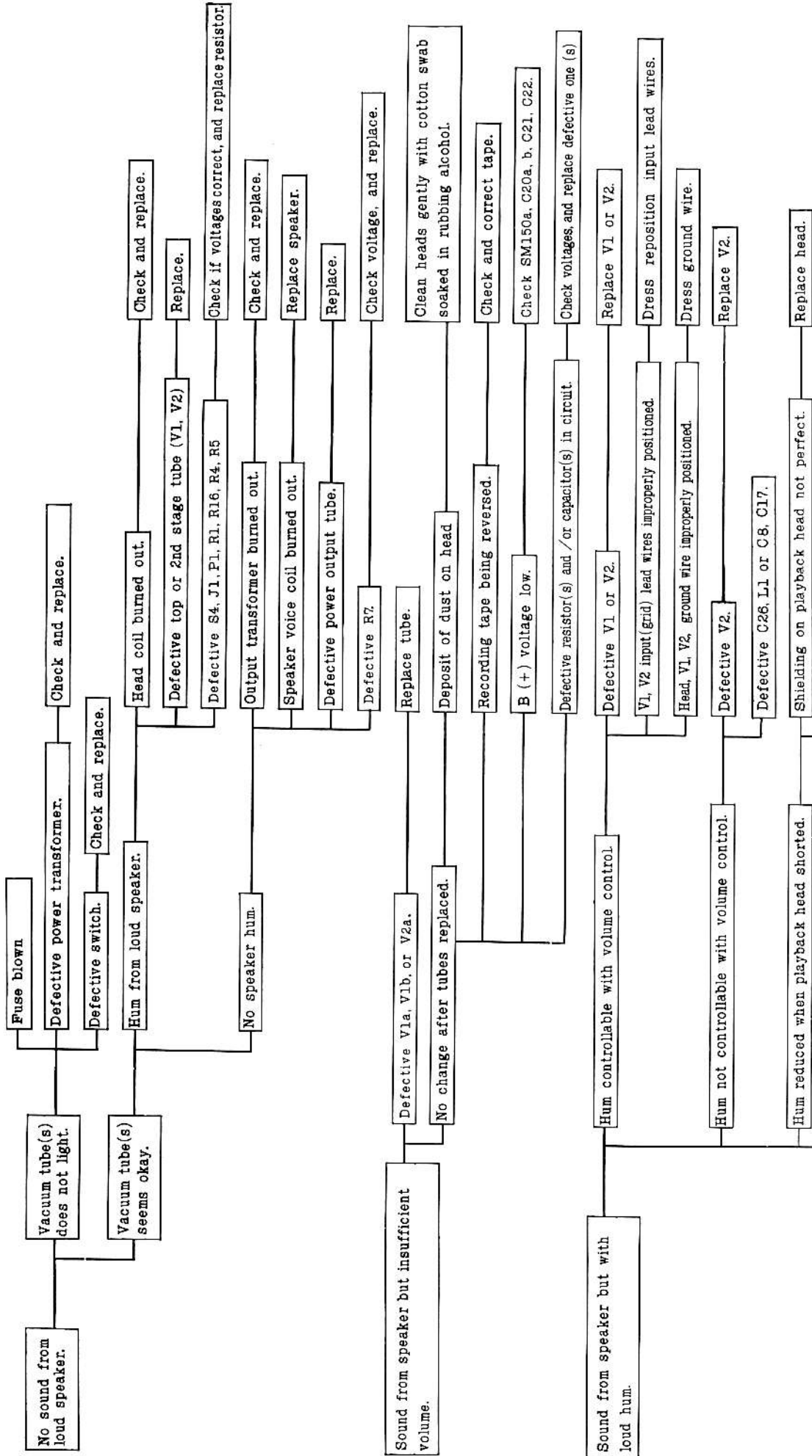

Defective C26, L1 or C8, C17.

Hum reduced when playback head shorted.

Replace head.

Shielding on playback head not perfect.

Check motor and power transformer, replace if necessary.

Leakage flux from motor or from power transformer.

Hum bucking coil out of adjustment.

Read just hum bucking coil.

Unit picks up external magnetic flux.

Ground recorder at capstan storage post.

Reposition recorder.

Shield recorder.

Renew recording.

Hum recorded on tape.

Noise level controllable with volume control.

Defective V1, C5, IN, Nf Circuit.

Replace V1.

Defective R4, R5.

Check R1, R6, R8 or R11 and replace.

Noise level not controllable with volume control.

Defective V2.

Replace V2.

Defective R7.

Check R7.

Output transformer being burned out.

Check and replace output transformer.

Noise only while tape is being played.

Uneven coating on recording tape.

Replace recording tape with new one.

Tape heads being magnetized.

Demagnetize heads using head demagnetizer.

Noise with or without tape on recorder.

Defective V1, V2.

Replace V1, V2.

Defective R1, R3 or R8.

Check R1, R3 or R8.

Defective C5, C7, C10, R2, VRL.

Check C5, C7, C10, R2, VRL.

Defective recording tape.

Replace recording tape.

Recording tape in close contact with tape heads.

Dust on tape heads.

Clean tape heads.

Record/play head mis-aligned. (Azimuth alignment of gap in recording head.)

Weak back tension.

Check supply reel shaft assembly and readjust spring tension.

Re-align head using standard alignment tape.

Worm-out tape heads.

Replace head assembly.

Defective V1 or V2.

Replace V1 or V2.

Incorrect circuit rating.

Check component parts in circuit by measuring voltage. See wiring diagram for regular voltage.

Defective loud speaker.

Replace loud speaker.

Constant background noise from speaker.

Intermittent noise.

Lack of bass.

Lack of treble.

Sound distorted.

2. Recording Problems.

(Unit plays back pre-recorded tapes okay, but recording not satisfactory.)

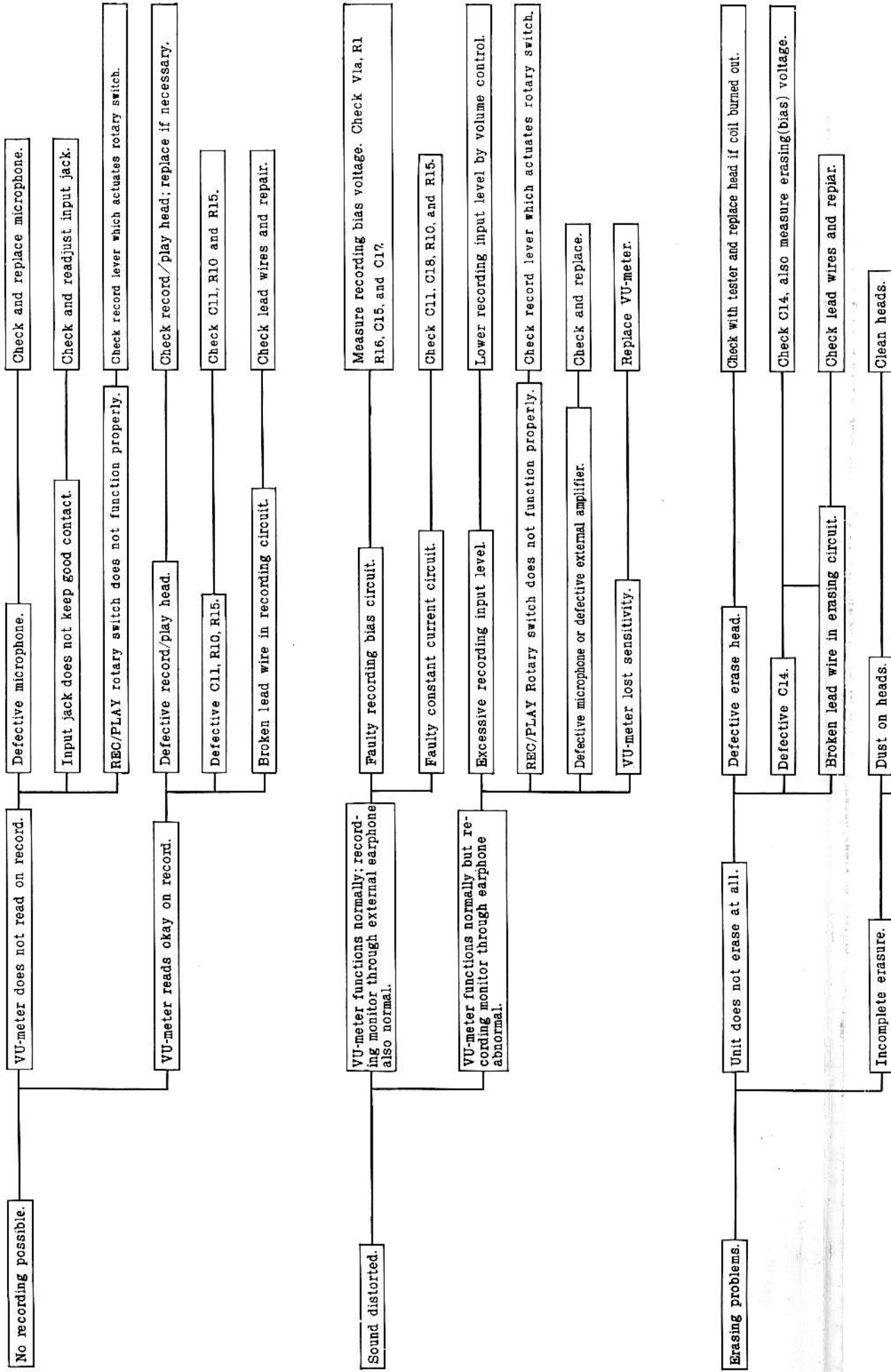

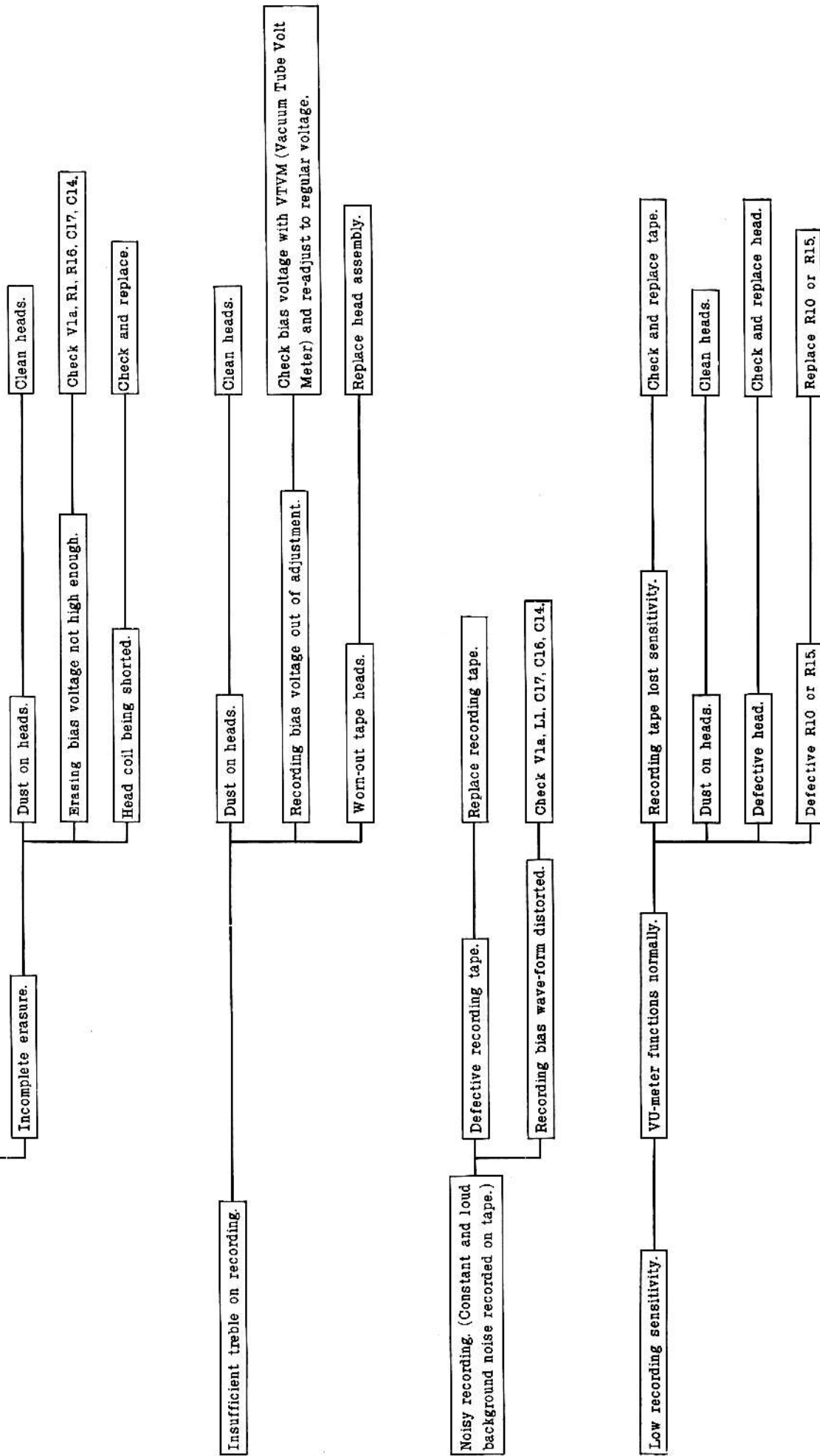

SECTION "B" TROUBLES WITH TAPE TRANSPORT MECHANISM.

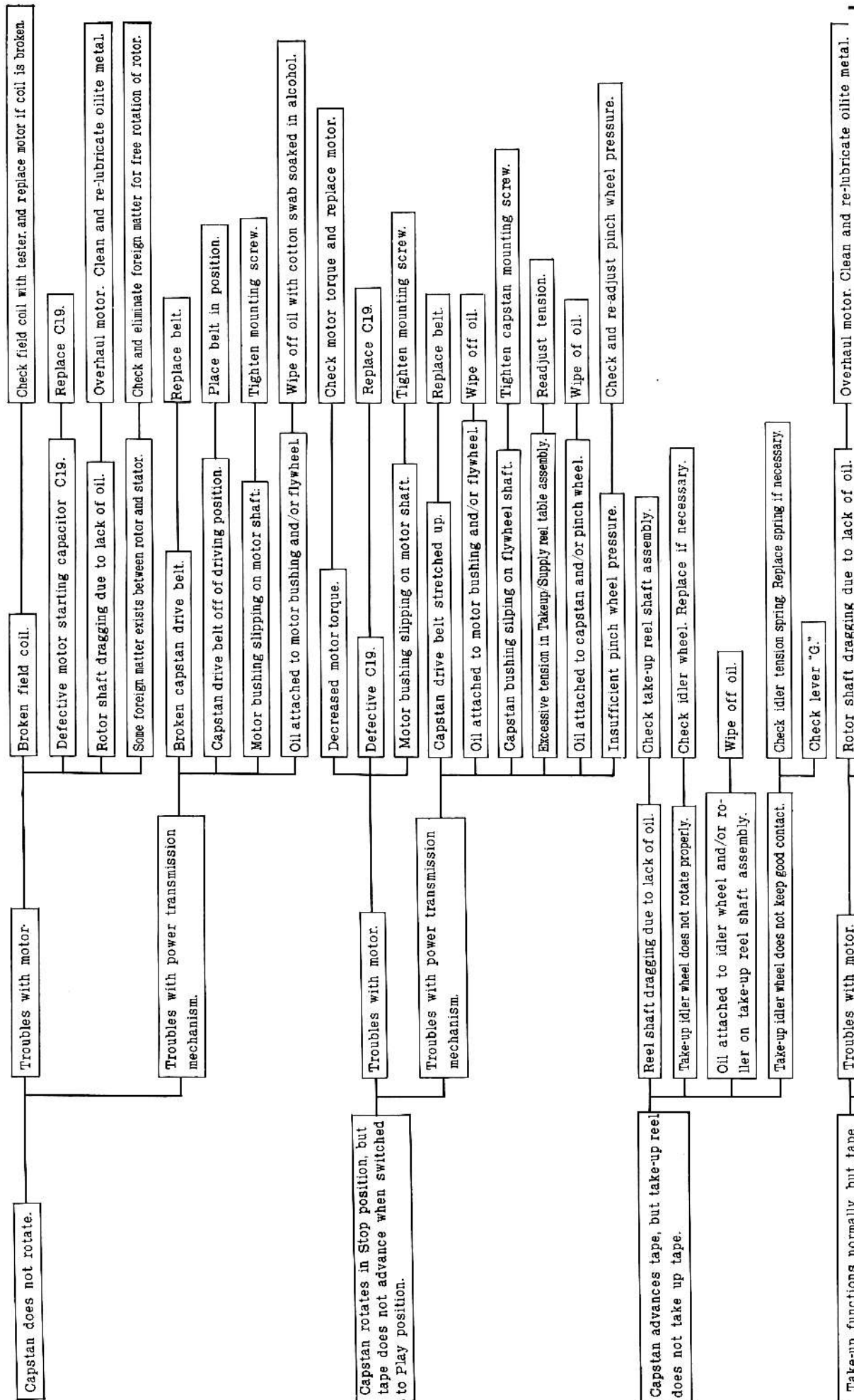

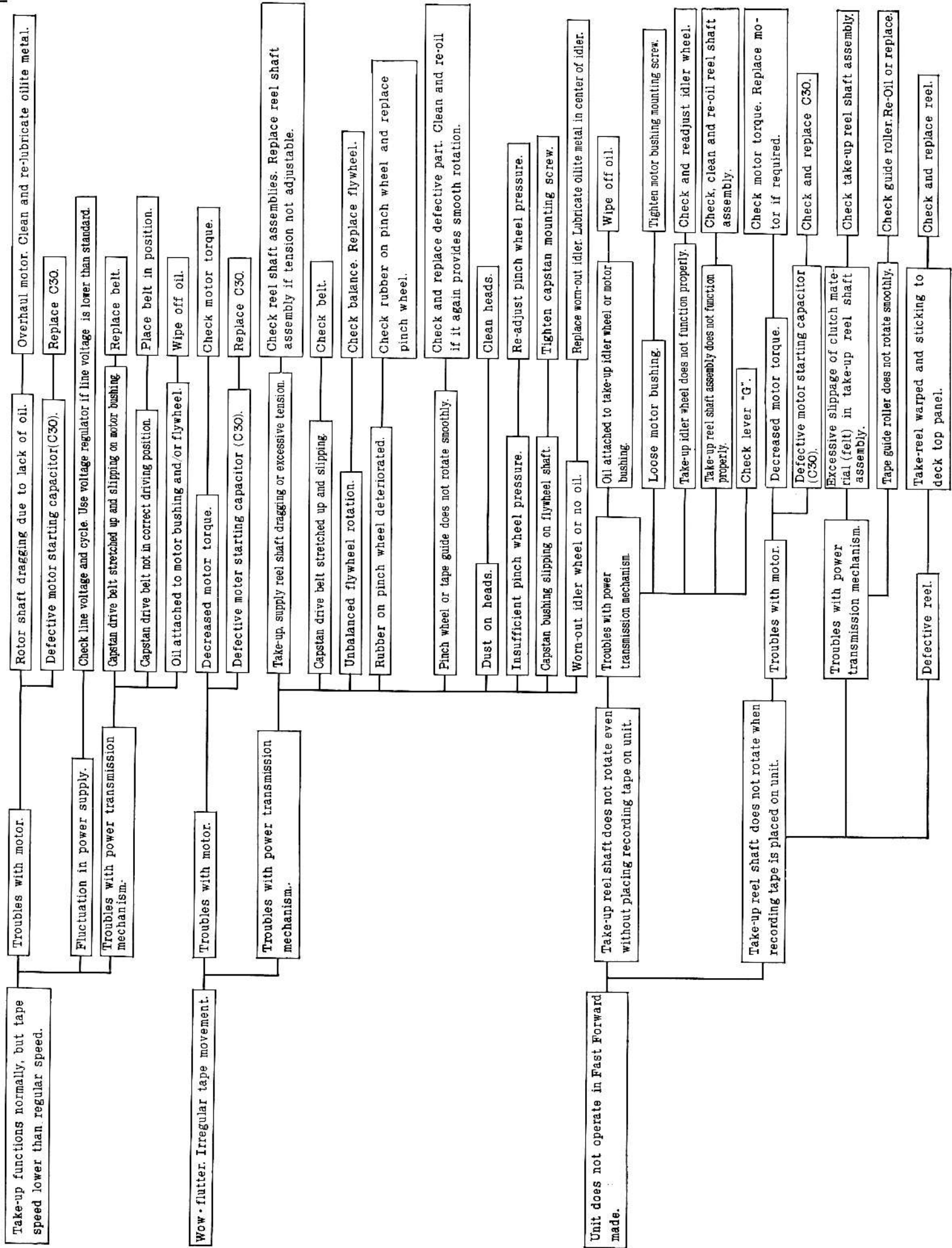

SECTION "B" TROUBLES WITH TAPE TRANSPORT MECHANISM.

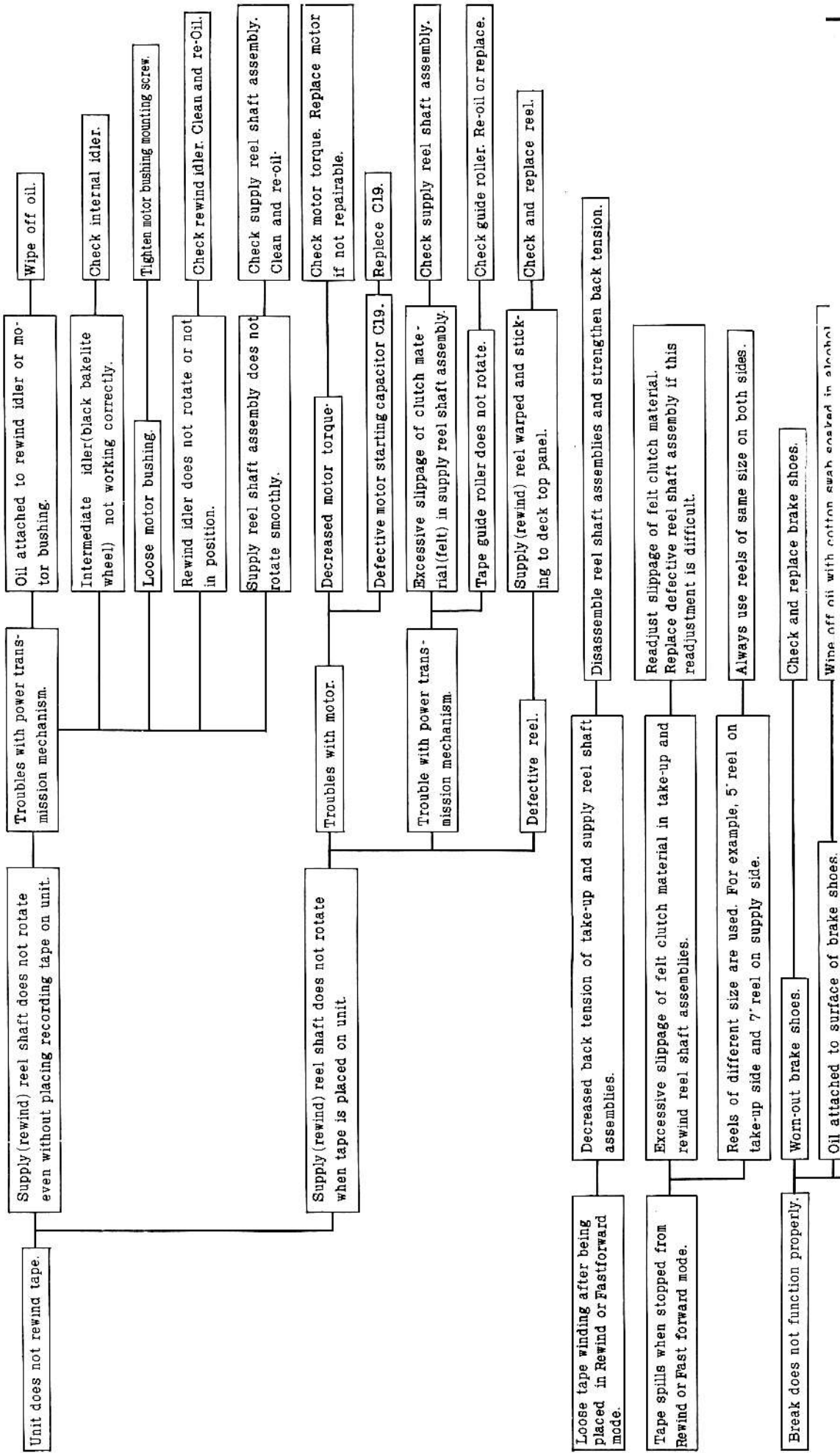

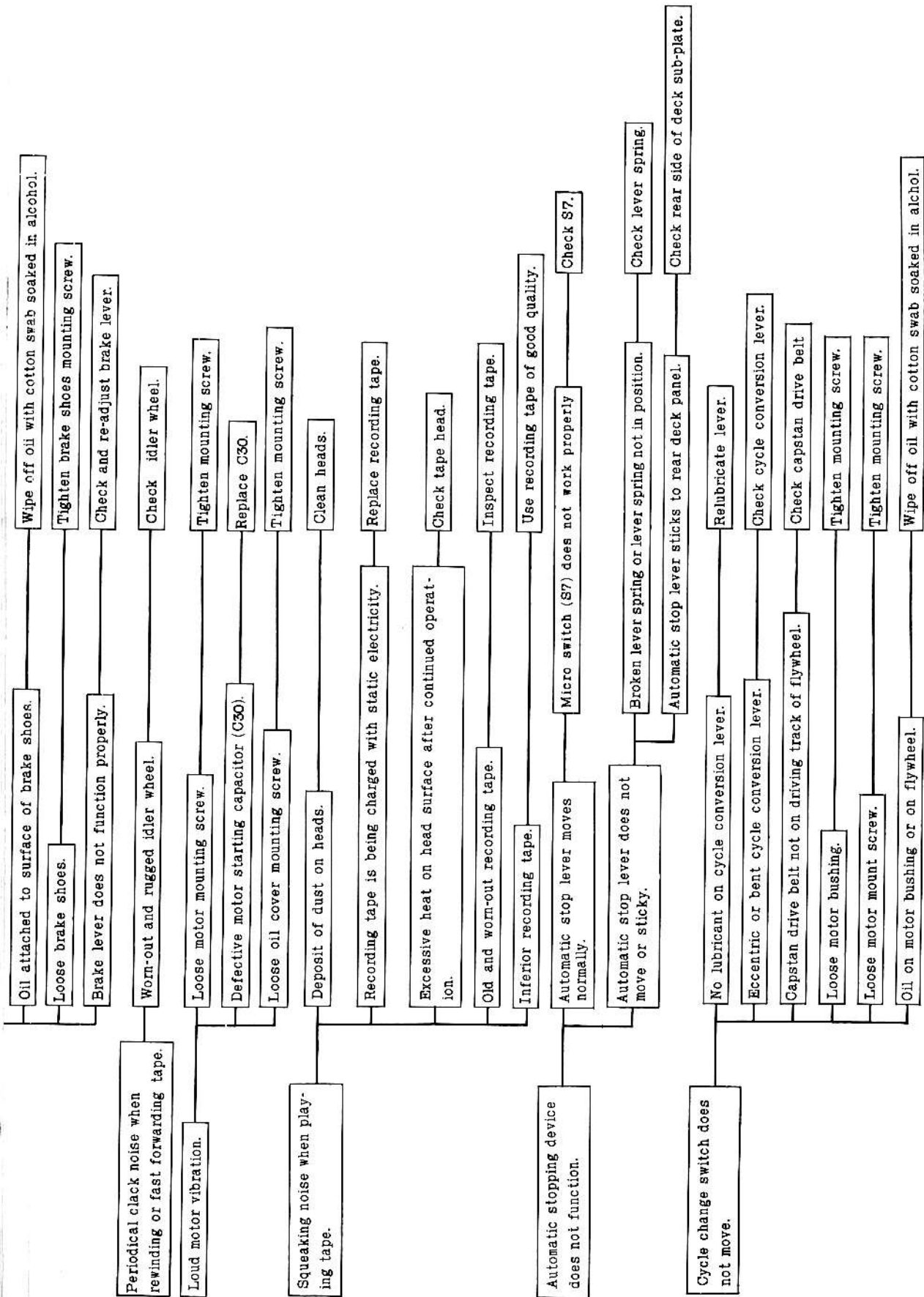

SCHEMATIC DIAGRAM

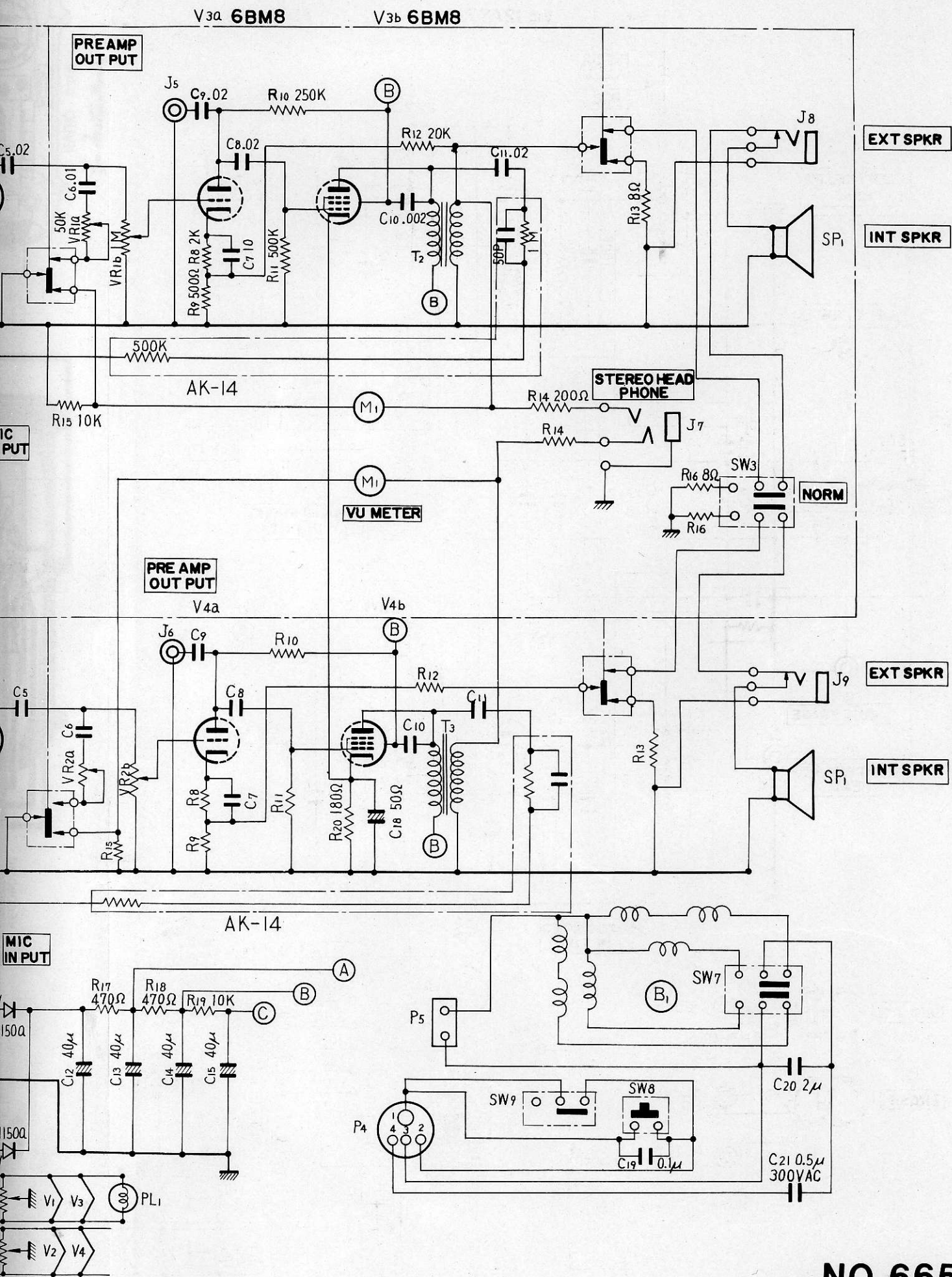

NO. 66505

XII SCHEMATIC

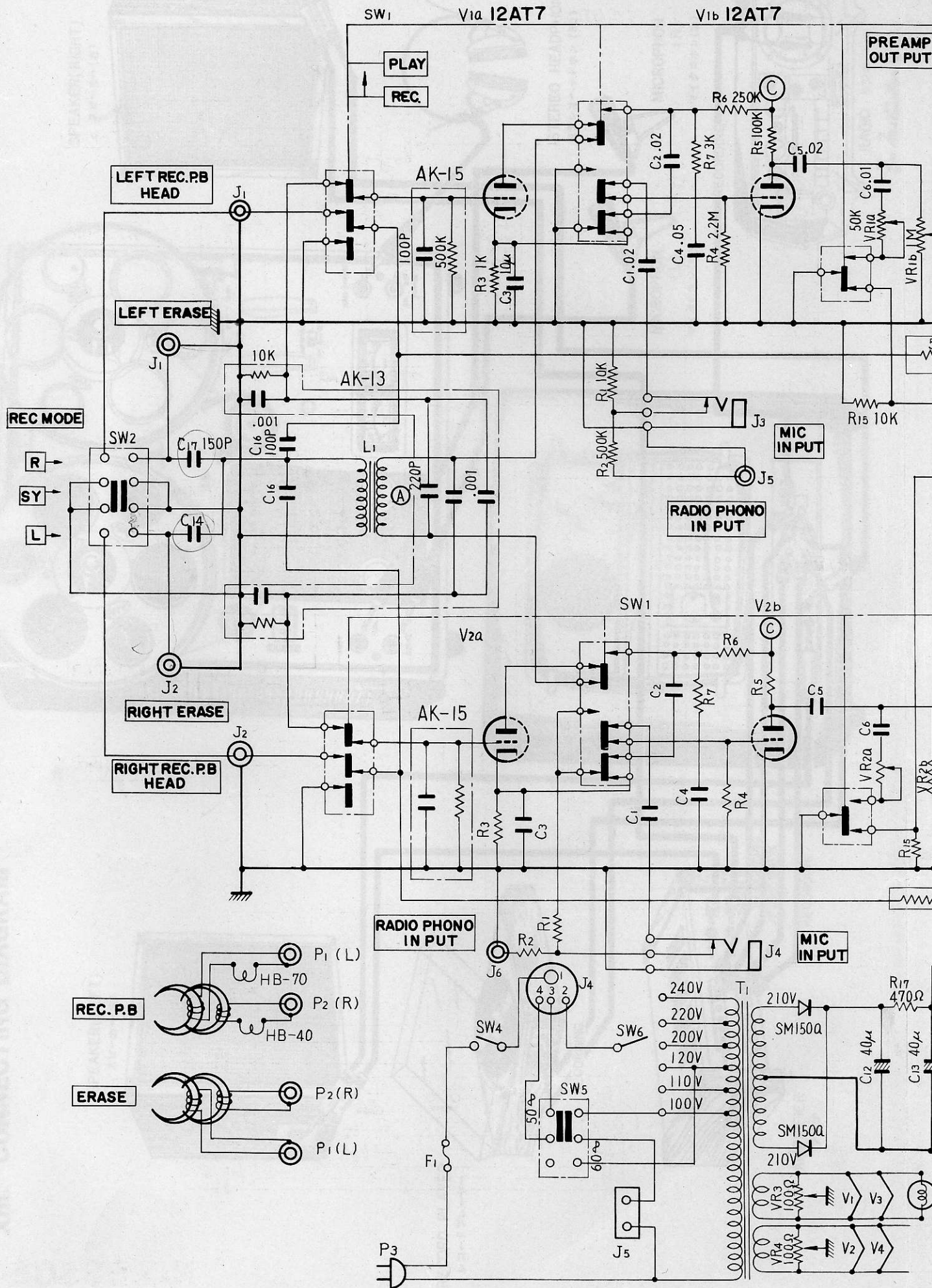

XIII. CONNECTING DIAGRAM

SPEAKER (LEFT)
スピーカー(左)

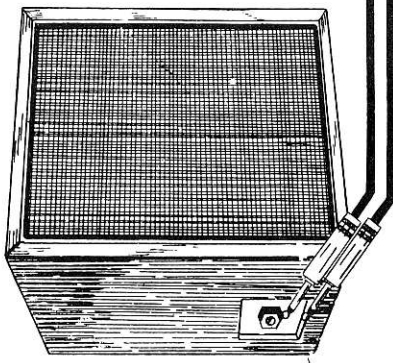

SPEAKER (RIGHT)
スピーカー(右)

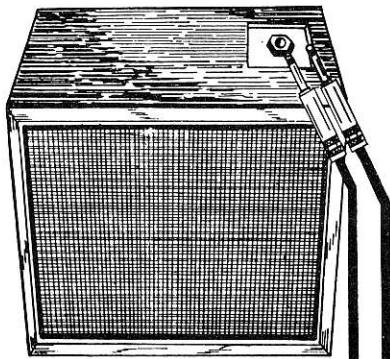

RECORD PLAYER
レコードプレーヤー

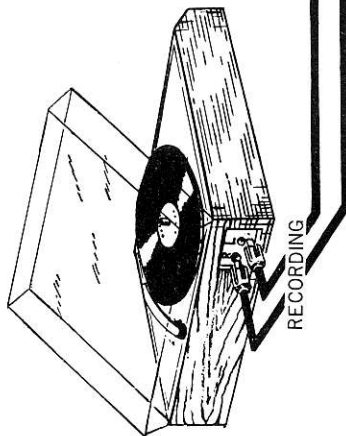

RECORDING

AMPLIFIER
アンプ

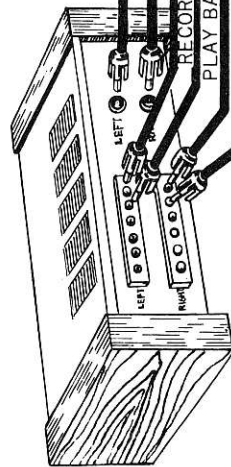

RECORDING

PLAY BACK

RECORDING

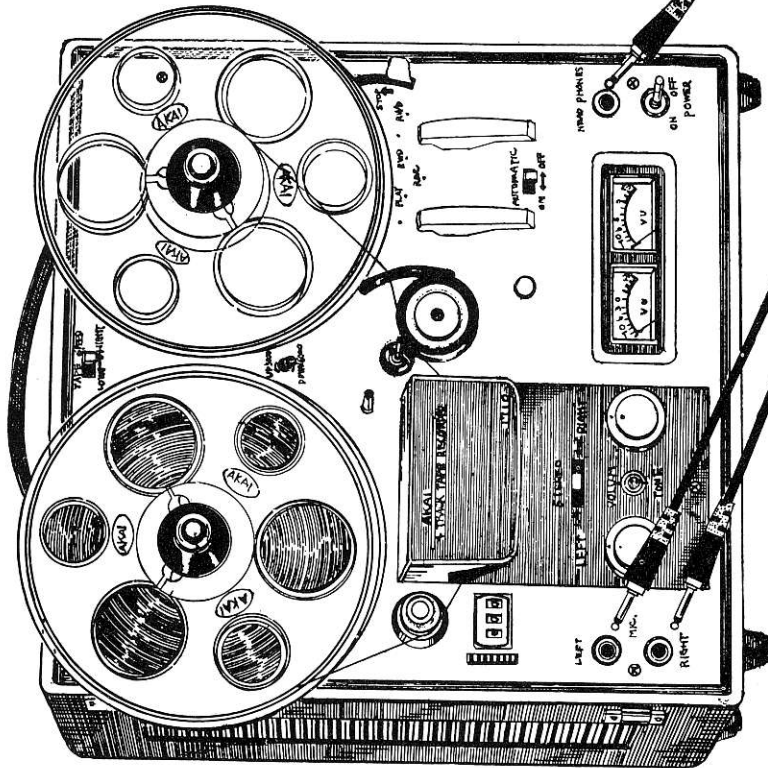

STEREO HEADPHONE
ステレオヘッドホン (8Ω)

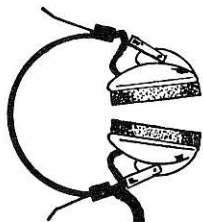

MICROPHON (R)
マイクホン(右)



MICROPHON (L)
マイクホン(左)



RECORDING

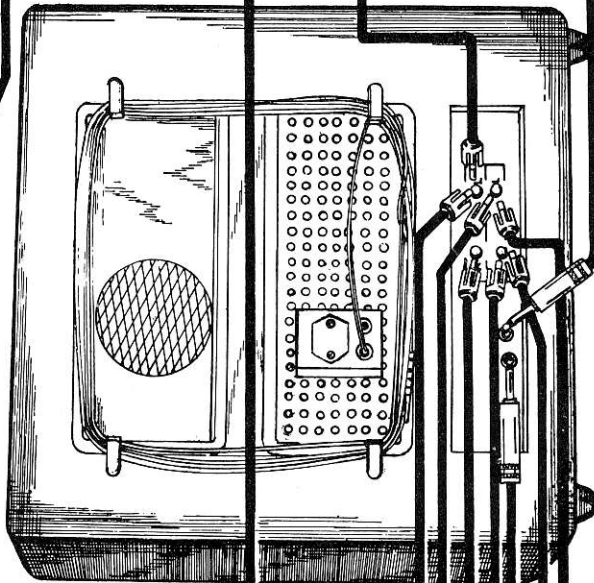

RADIO ラジオ

J. Matsubara



AKAI ELECTRIC CO., LTD.
AKAI TRADING CO., LTD.

**12, 2-chome, Higashi-Kojiya,
Ohta-ku, Tokyo, Japan.**

Price ¥ 900.00
\$ 2.50

Printed in Japan