

Service
Service
Service

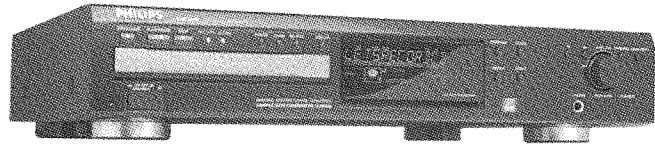

Service Manual

SERVICING

For servicing CDR600 and CDR602 the set can be divided into two parts:

- 1. Except for the CD-R/W module all workshops can repair the set on component level.
The Switched Mode Power Supply unit is available as a sparepart, but can also be repaired on component level.
- 2. The **CD-R/W module** can only be repaired on component level with the help of COMPAIR, Release 1.6 and higher.
With this tool diagnosing of the set can be done in an interactive way. In the tool also the adjustment procedure has been implemented. This is absolutely necessary in case the CDR Main Board and/or CD drive (CDR Loader) is disconnected from the matched production combination.
Only designated workshops can perform these repairs!
Please send the complete set to the designated workshop.



Available circuit descriptions: *The Basics of Compact Disc Recordable/Rewritable* 4822 725 25242
3rd generation Compact Disc Recording 3104 125 40100

TABLE OF CONTENTS

	page		page
Technical Specification	2	I/O BOARD	32
Warnings and Servicing Hints	3	POWER BOARD	32b
Brief Operating Instructions	6	Diagnostic Software	33
MECHANICAL INSTRUCTIONS		Faultfinding trees	37
Wiring Diagram	25	Faultfinding guide	41
Exploded View	26	List of Abbreviations	51
Dismantling Instructions	27	Partslist	56
ELECTRICAL AND CIRCUIT DIAGRAMS			
Overall Block diagram	28		
DISPLAY BOARD	29		
HEADPHONE/IR BOARD	31		

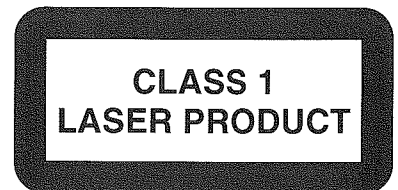

© Copyright 2001 Philips Consumer Electronics B.V. Eindhoven, The Netherlands
All rights reserved. No part of this publication may be reproduced, stored in a retrieval system or transmitted, in any form or by any means, electronic, mechanical, photocopying, or otherwise without the prior permission of Philips.

Published by MS 0115 Service Audio Printed in The Netherlands Subject to modification

GB 3103 785 25090



PHILIPS

I/O BOARD - CIRCUIT DIAGRAM

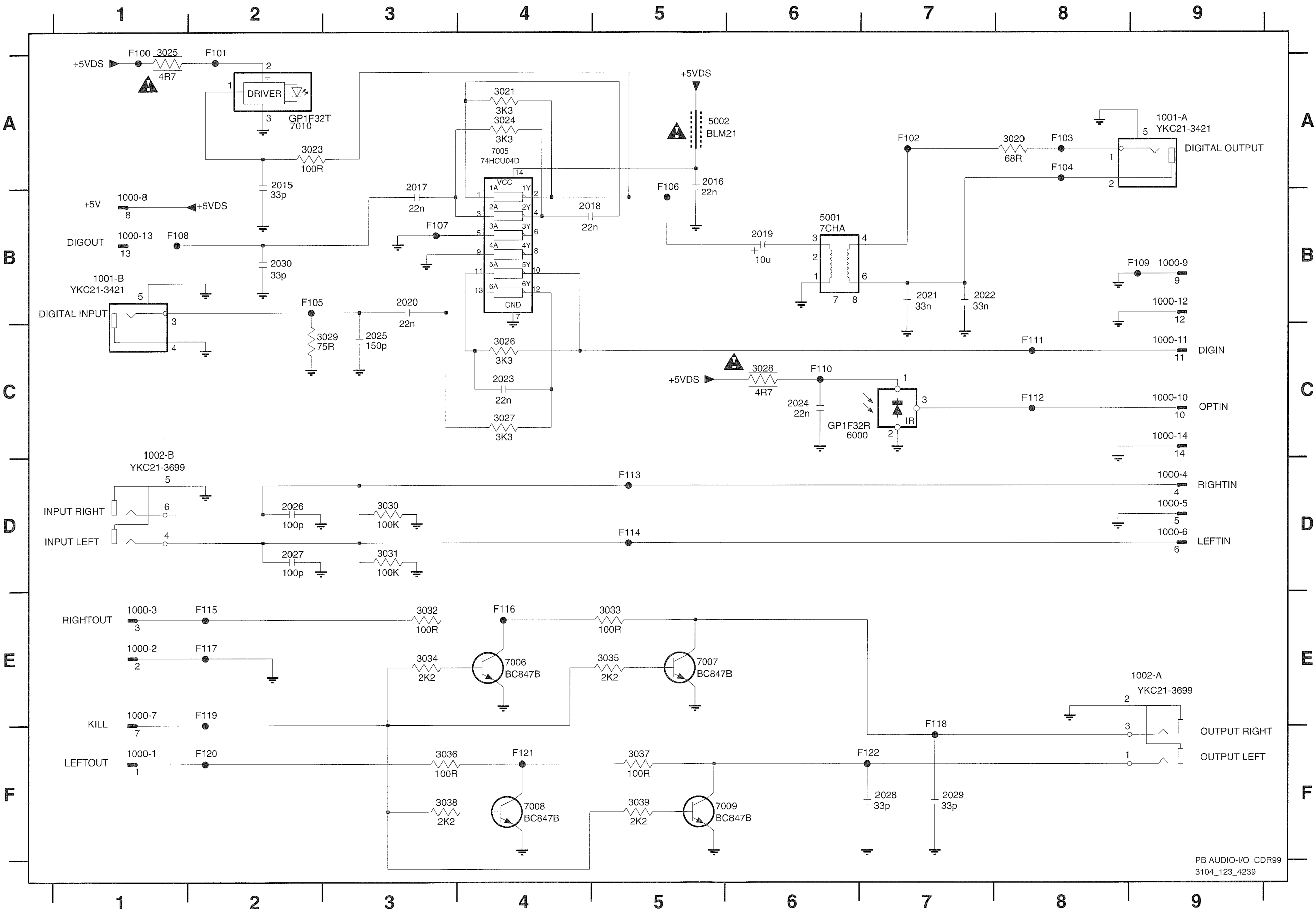

- 1000-1 F1
- 1000-10 C9
- 1000-11 C9
- 1000-12 B9
- 1000-13 B1
- 1000-14 C9
- 1000-2 E1
- 1000-3 E1
- 1000-4 D9
- 1000-5 D9
- 1000-6 D9
- 1000-7 E1
- 1000-8 B1
- 1000-9 B9
- 1001-A A9
- 1001-B B1
- 1002-A E9
- 1002-B D1
- 2015 A2
- 2016 A5
- 2017 B3
- 2018 B4
- 2019 B6
- 2020 B3
- 2021 B7
- 2022 B7
- 2023 C4
- 2024 C6
- 2025 C3
- 2026 D2
- 2027 D2
- 2028 F7
- 2029 F7
- 2030 B2
- 3020 A8
- 3021 A4
- 3023 A2
- 3024 A4
- 3025 A1
- 3026 C4
- 3027 C4
- 3028 C6
- 3029 C3
- 3030 D3
- 3031 D3
- 3032 E3
- 3033 E5
- 3034 E3
- 3035 E5
- 3036 F3
- 3037 F5
- 3038 F3
- 3039 F5
- 3999 F9
- 5001 B6
- 5002 A5
- 6000 C7
- 7005 A4
- 7006 E4
- 7007 E5
- 7008 F4
- 7009 F5
- 7010 A2

I/O BOARD - TOP VIEW

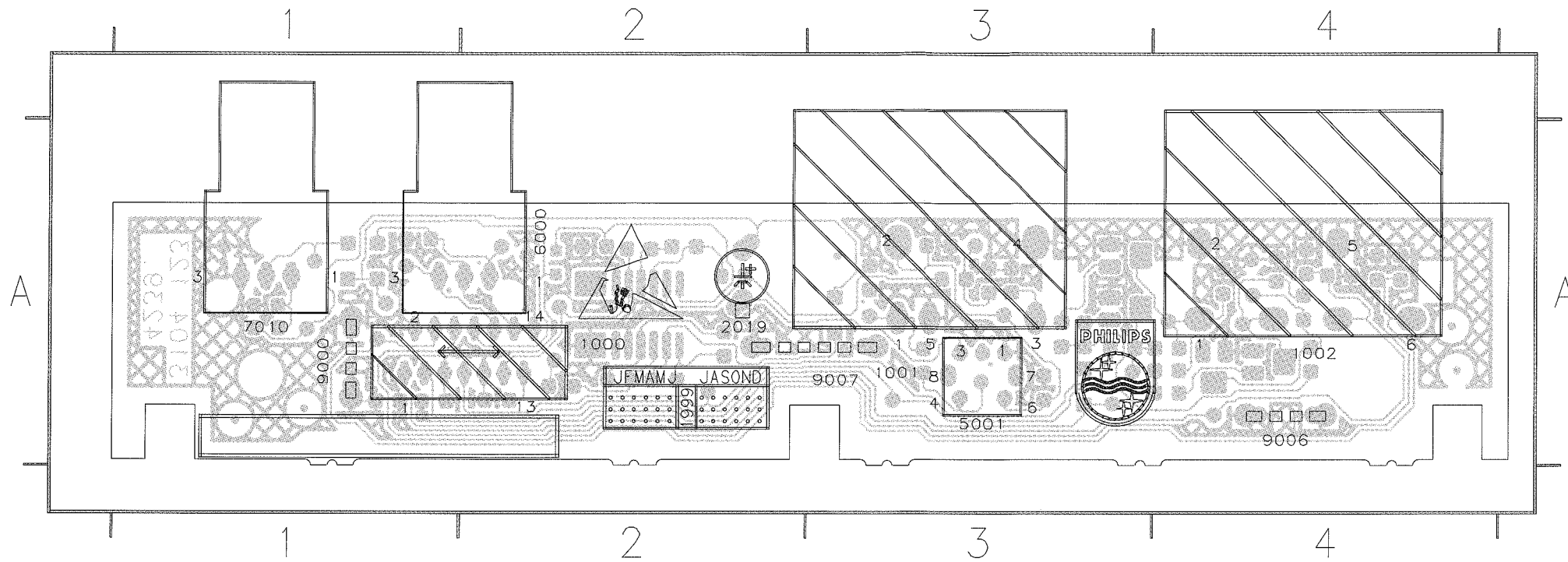

1000	A2
1001	A3
1002	A4
2019	A2
5001	A3
6000	A2
7010	A1
9000	A1
9006	A4
9007	A3

I/O BOARD - BOTTOM VIEW

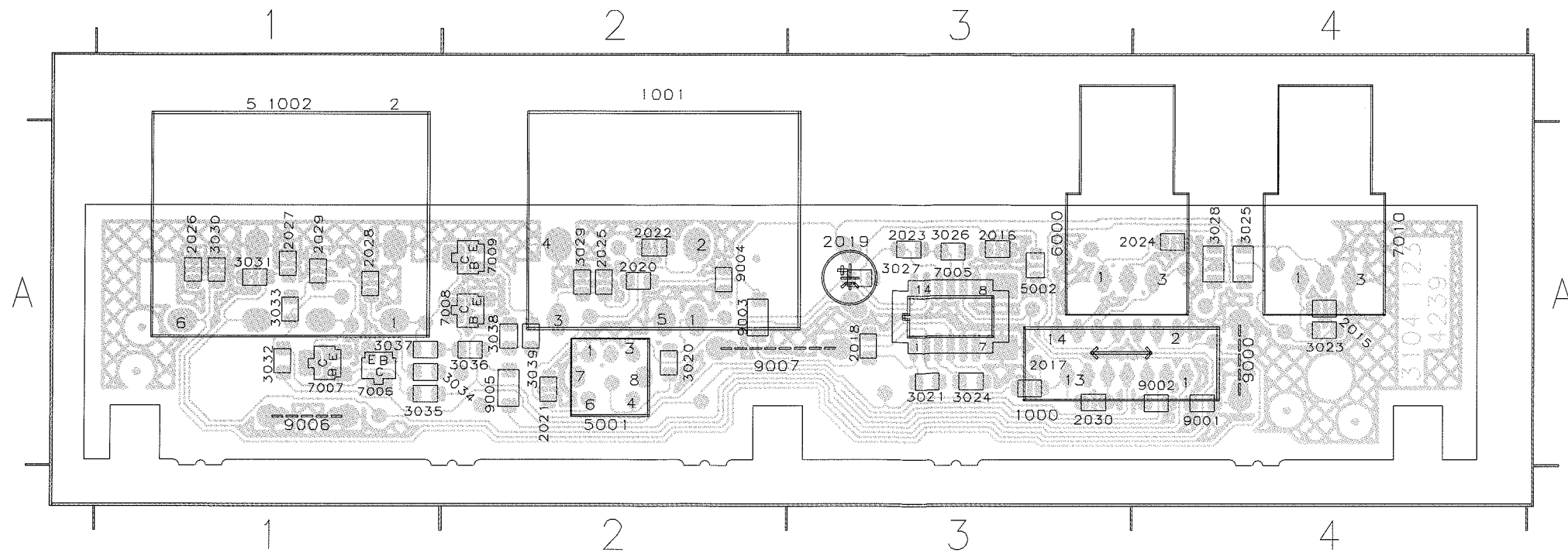

2015	A4	3034	A2
2016	A3	3035	A1
2017	A3	3036	A2
2018	A3	3037	A1
2019	A2	3038	A2
2020	A2	3039	A2
2021	A2	5002	A4
2022	A3	7005	A3
2023	A4	7006	A3
2024	A2	7007	A1
2025	A1	7008	A1
2026	A1	7009	A2
2027	A1	7008	A2
2028	A1	7009	A2
2029	A1	9001	A4
2030	A3	9002	A4
3020	A2	9003	A2
3021	A3	9004	A2
3022	A3	9005	A2
3023	A4		
3024	A3		
3025	A4		
3026	A3		
3027	A3		
3028	A4		
3029	A2		
3030	A1		
3031	A1		
3032	A1		
3033	A1		

POWER SUPPLY UNIT CDR3-ECO

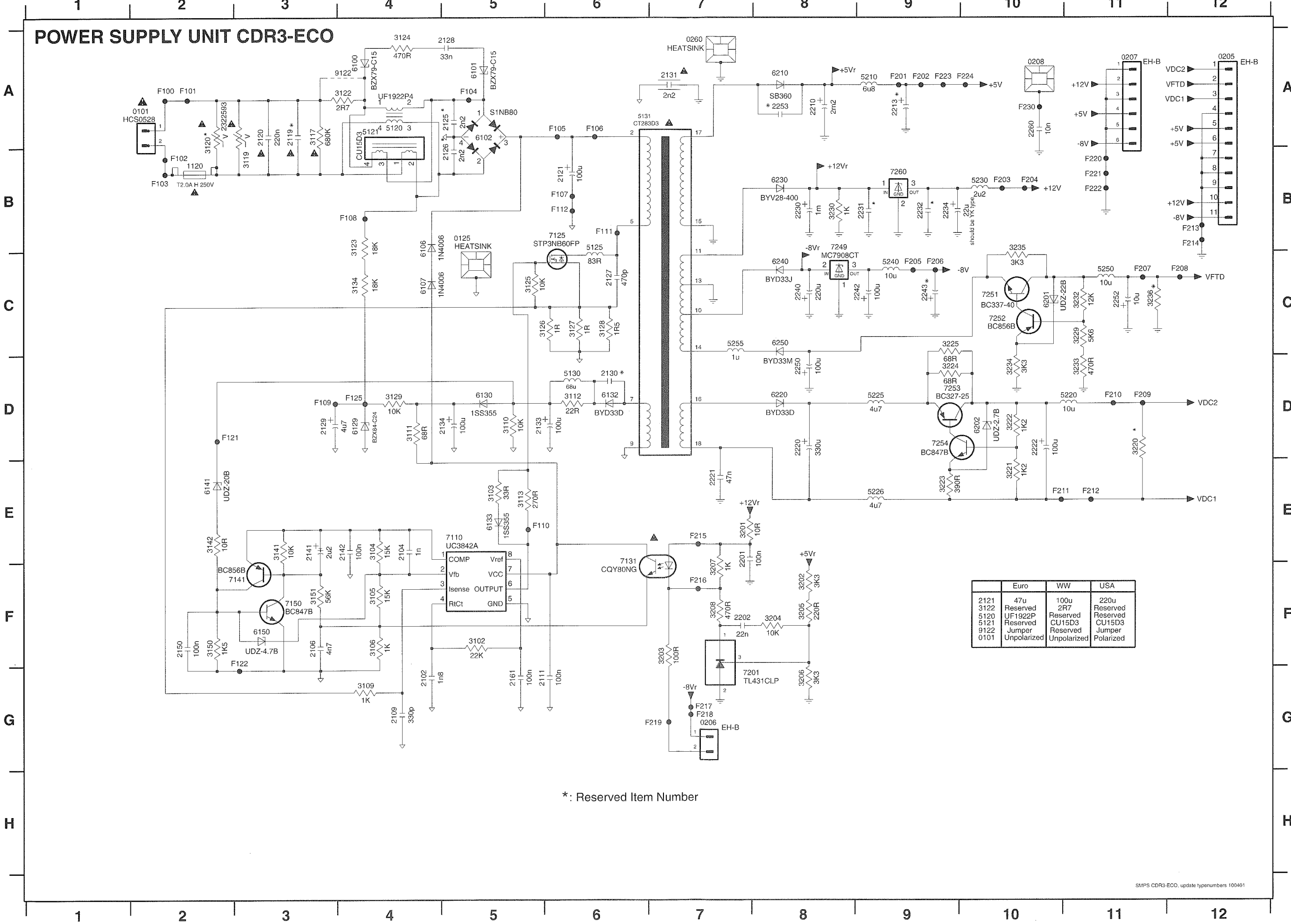

	Euro	WW	USA
2121	47u	100u	220u
3122	Reserved	2R7	Reserved
5120	Reserved	Reserved	Reserved
5121	Reserved	Reserved	Reserved
9122	Jumper	Reserved	Jumper
0101	Unpolarized	Unpolarized	Polarized

*: Reserved Item Number

- 0101 A2
- 0125 B5
- 0205 A12
- 0206 G7
- 0207 A11
- 0208 A10
- 0260 A7
- 1120 B2
- 2102 G4
- 2104 E4
- 2106 F3
- 2109 G4
- 2111 G5
- 2119 A3
- 2120 A3
- 2121 B6
- 2125 A5
- 2126 B5
- 2127 C6
- 2128 A5
- 2129 D3
- 2130 D6
- 2131 A7
- 2133 D5
- 2134 D5
- 2141 E3
- 2142 E4
- 2150 F2
- 2161 G5
- 2201 E7
- 2202 F7
- 2210 A8
- 2213 A9
- 2220 D8
- 2221 E7
- 2222 D10
- 2230 B8
- 2231 B9
- 2232 B9
- 2234 B9
- 2240 C8
- 2242 C9
- 2243 C9
- 2250 D8
- 2252 C11
- 2253 A8
- 2260 A10
- 3102 F5
- 3103 E5
- 3104 E4
- 3105 F4
- 3106 F4
- 3109 G4
- 3110 D5
- 3111 D4
- 3112 D6
- 3113 E5
- 3117 A3
- 3119 B3
- 3120 A2
- 3122 A4
- 3123 B4
- 3124 A4
- 3125 C5
- 3126 C6
- 3127 C6
- 3128 C6
- 3129 D4
- 3134 C4
- 3141 E3
- 3142 E2
- 3150 F2
- 3151 F3
- 3201 E7
- 3202 F8
- 3203 F7
- 3204 F8
- 3205 F8
- 3206 G8
- 3207 F7
- 3208 F7
- 3220 D11
- 3221 E10
- 3222 D10
- 3223 E9
- 3224 D9
- 3225 C9
- 3229 C11
- 3230 B8
- 3232 C11
- 3233 D11
- 3234 D10
- 3235 B10
- 3236 C11
- 5120 A4
- 5121 A4
- 5125 B6
- 5130 D6
- 5131 A6
- 5210 A9
- 5220 D11
- 5225 D9
- 5226 E9
- 5230 B10
- 5240 C9
- 5240 D9
- 5240 E9
- 5240 F9
- 5240 G9
- 5240 H9
- 5240 I9
- 5240 J9
- 5240 K9
- 5240 L9
- 5240 M9
- 5240 N9
- 5240 O9
- 5240 P9
- 5240 Q9
- 5240 R9
- 5240 S9
- 5240 T9
- 5240 U9
- 5240 V9
- 5240 W9
- 5240 X9
- 5240 Y9
- 5240 Z9

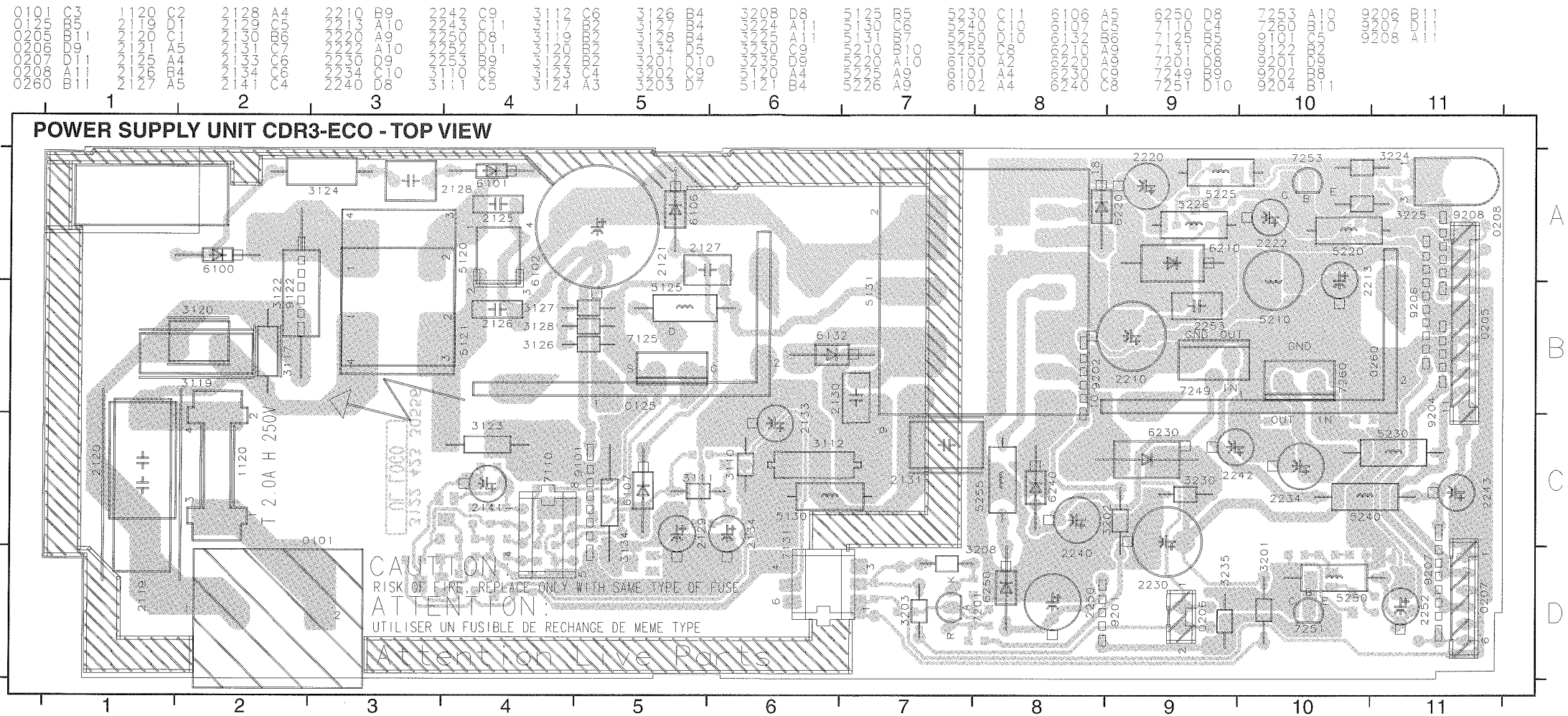

2102 A4	2111 A4	2201 A7	2232 B10	3104 B4	3113 B5	3142 A4	3205 A8	3221 D9	3232 A10	4101 B5	6141 A4	7141 B4
2104 B4	2142 B4	2202 A8	2260 D11	3105 A3	3125 B5	3150 B4	3206 A8	3233 D9	3234 A10	4120 B5	6150 A3	7150 A3
2106 A4	2150 A4	2221 D8	3102 A4	3106 B4	3134 B4	3207 A7	3208 D10	3235 A11	3236 A11	4120 B5	6201 A10	7252 A10
2109 B4	2161 B4	2231 B10	3103 B5	3109 B4	3135 B4	3220 D10	3229 A10	3237 A11	3238 A11	4120 B5	6202 D9	7253 A10

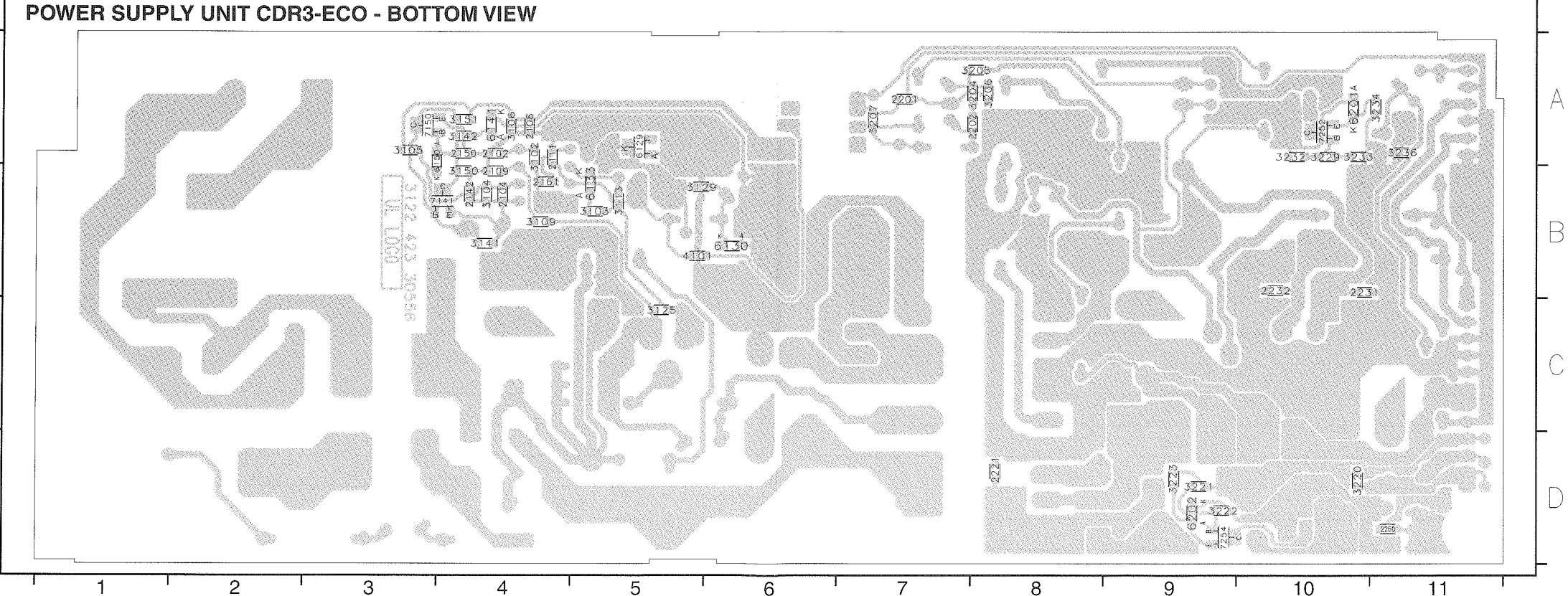

5. Electrical and Circuit Diagrams

BLOCK DIAGRAM

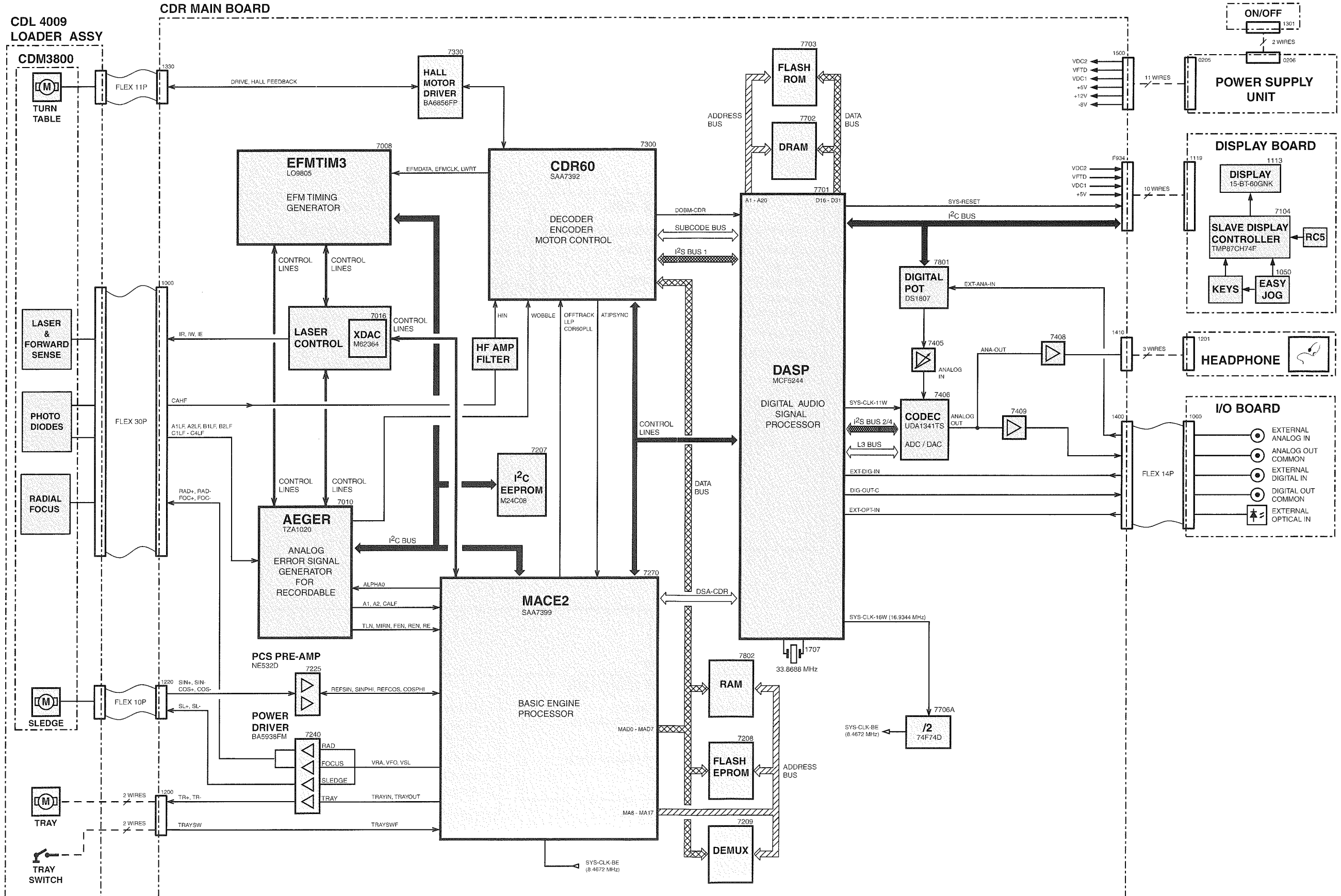

DISPLAY BOARD - CIRCUIT DIAGRAM

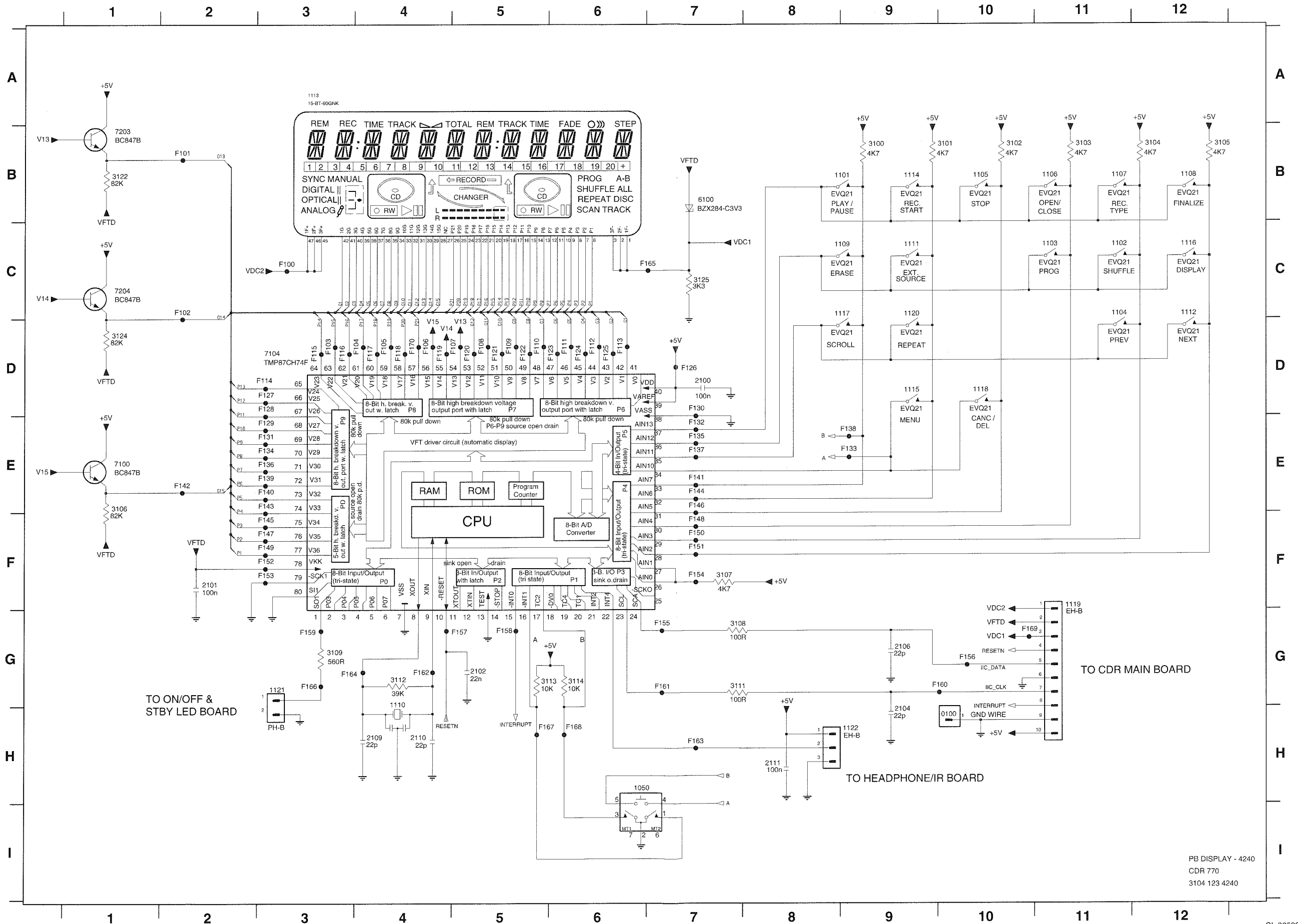

- 0100 H10
- 1050 H6
- 1101 B9
- 1102 C11
- 1103 C11
- 1104 C11
- 1105 B10
- 1106 B11
- 1107 B11
- 1108 B12
- 1109 C9
- 1110 H4
- 1111 C9
- 1112 C12
- 1113 A3
- 1114 B9
- 1115 D9
- 1116 C12
- 1117 C9
- 1118 D10
- 1119 F11
- 1120 C9
- 1121 G3
- 1122 H9
- 2100 D7
- 2101 F2
- 2102 G5
- 2104 H9
- 2106 G9
- 2109 H4
- 2110 H4
- 2111 H8
- 3100 B9
- 3101 B10
- 3102 B10
- 3103 B11
- 3104 B12
- 3105 B12
- 3106 E1
- 3107 F7
- 3108 G7
- 3109 G3
- 3111 G7
- 3112 G4
- 3113 G6
- 3114 G6
- 3122 B1
- 3124 D1
- 3125 C7
- 6100 B7
- 7100 E1
- 7104 D3
- 7203 B1
- 7204 C1

PB DISPLAY - 4240
 CDR 770
 3104 123 4240

DISPLAY BOARD - FRONT VIEW

0100 A10 1050 A11 1102 A8 1104 A10 1106 A1 1108 A3 1110 A6 1112 A10 1114 A2 1116 A3 1118 A10 1120 A9 1200 A2 1201 A3 1300 A11 1302 A2 6300 A11 9017 A6 9019 A5 9023 A5 9025 A5 9027 A5 9029 A5 9032 A6 9035 A7 9043 A8 9045 A8 9061 A10 9070 A11
0200 A3 1101 A1 1103 A8 1105 A2 1107 A2 1109 A3 1111 A4 1113 A6 1115 A2 1117 A3 1119 A10 1202 A2 1290 A3 1301 A11 6200 A2 9016 A5 9018 A6 9022 A8 9024 A5 9026 A5 9028 A5 9030 A6 9033 A7 9035 A8 9044 A8 9047 A8 9062 A10 9200 A2

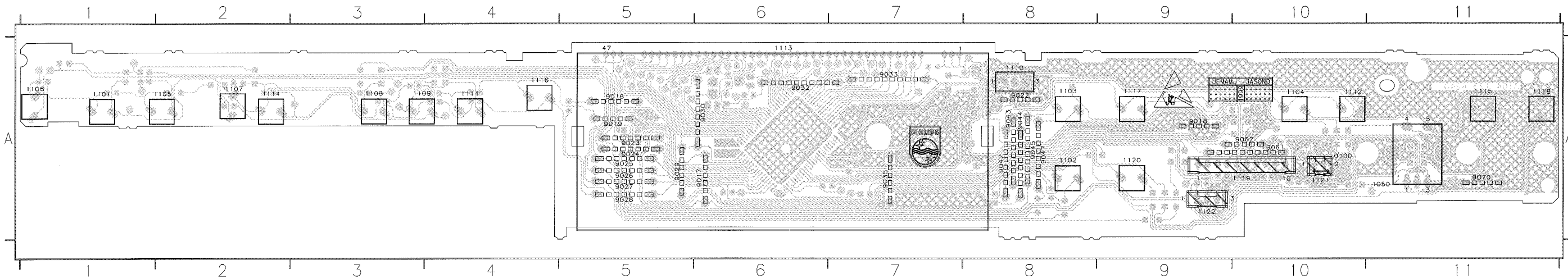

DISPLAY BOARD - BACK VIEW

2100 A7 2106 A2 2200 A9 3100 A11 3104 A10 3108 A5 3113 A2 3125 A4 7100 A6 7999 A6 9003 A10 9007 A9 9011 A8 9015 A8 9034 A5 9039 A4 9048 A4 9052 A3 9056 A3 9060 A2 9066 A2 9071 A10 9077 A1
2101 A5 2109 A5 2201 A9 3101 A10 3105 A9 3109 A2 3114 A2 3200 A10 7104 A6 9000 A11 9004 A10 9008 A9 9012 A8 9020 A7 9036 A4 9040 A5 9049 A4 9053 A3 9057 A3 9063 A2 9067 A2 9073 A4 9080 A7
2102 A5 2110 A5 2202 A10 3102 A11 3106 A6 3111 A6 3122 A6 3999 A8 7203 A6 9001 A11 9005 A10 9009 A8 9013 A8 9021 A7 9037 A4 9041 A4 9050 A4 9054 A3 9058 A2 9064 A2 9068 A2 9075 A2 9081 A7
2104 A2 2111 A3 2203 A10 3103 A11 3107 A6 3112 A5 3124 A6 6100 A5 7204 A6 9002 A10 9006 A9 9010 A8 9014 A8 9031 A6 9038 A4 9046 A4 9051 A3 9055 A3 9059 A2 9065 A2 9069 A2 9076 A1 9081 A7

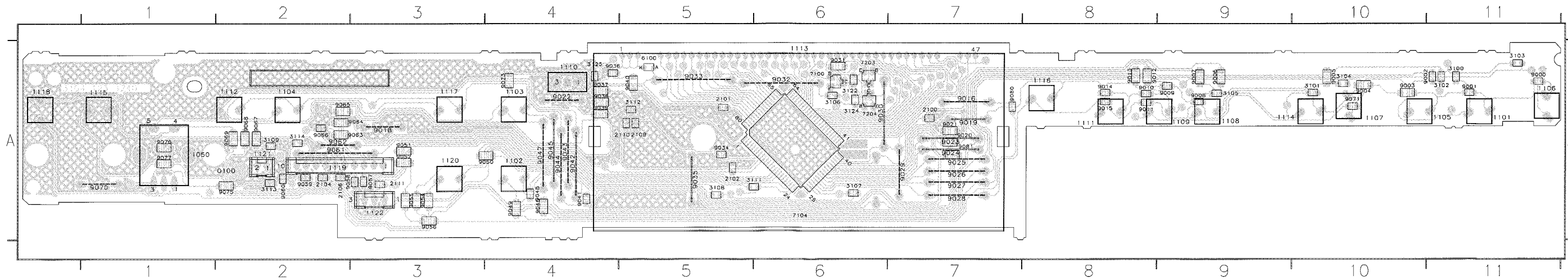

HEADPHONE/IR BOARD - CIRCUIT DIAGRAM

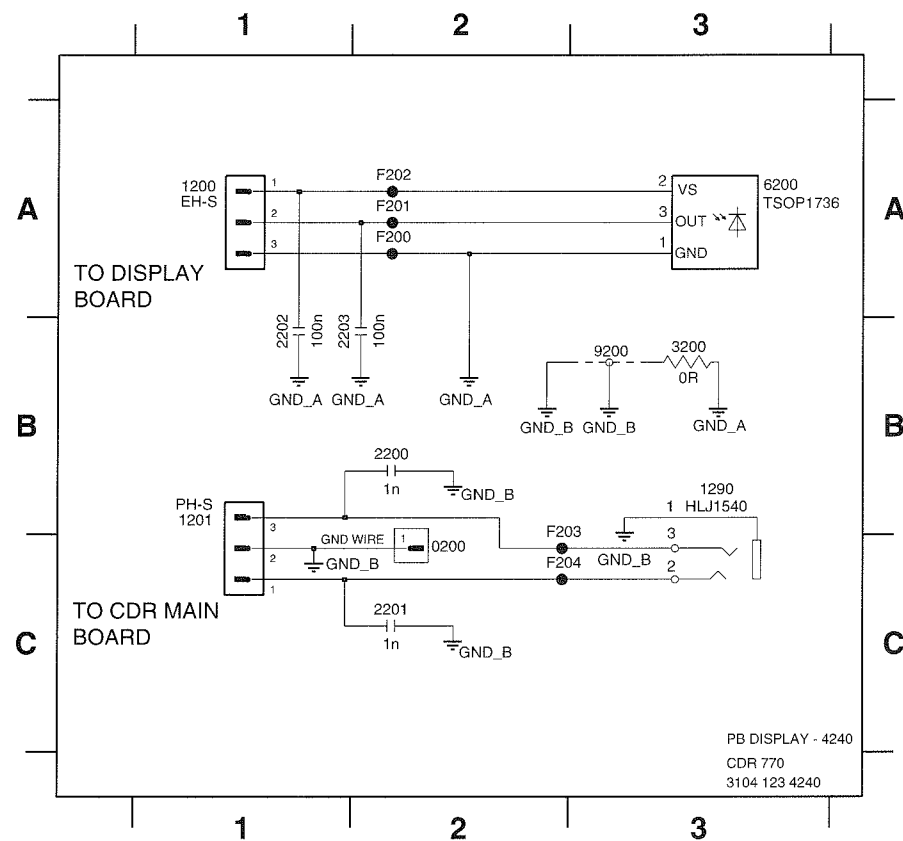

- 0200 C2
- 1200 A1
- 1201 B1
- 1290 B3
- 2200 B2
- 2201 C2
- 2202 B1
- 2203 B1
- 3200 B3
- 6200 A3
- 9200 B3
- F200 A2
- F201 A2
- F202 A2
- F203 C2
- F204 C2

HEADPHONE & IR BOARD TOP VIEW

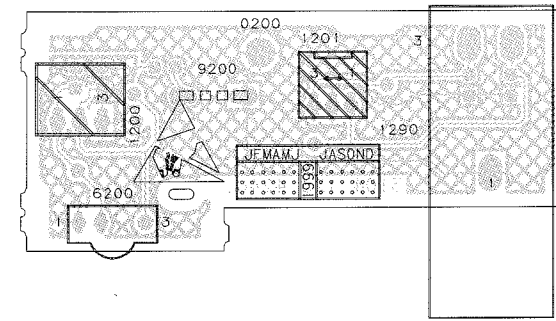

HEADPHONE/IR BOARD - BOTTOM VIEW

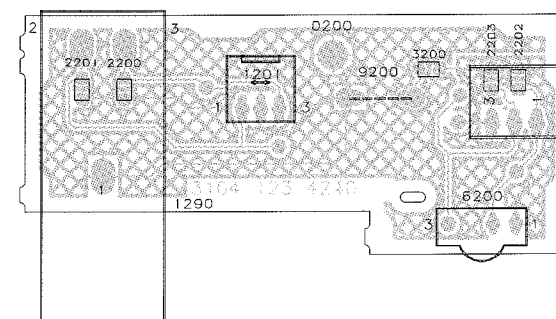

ON/OFF & STBY LED BOARD - CIRCUIT DIAGRAM

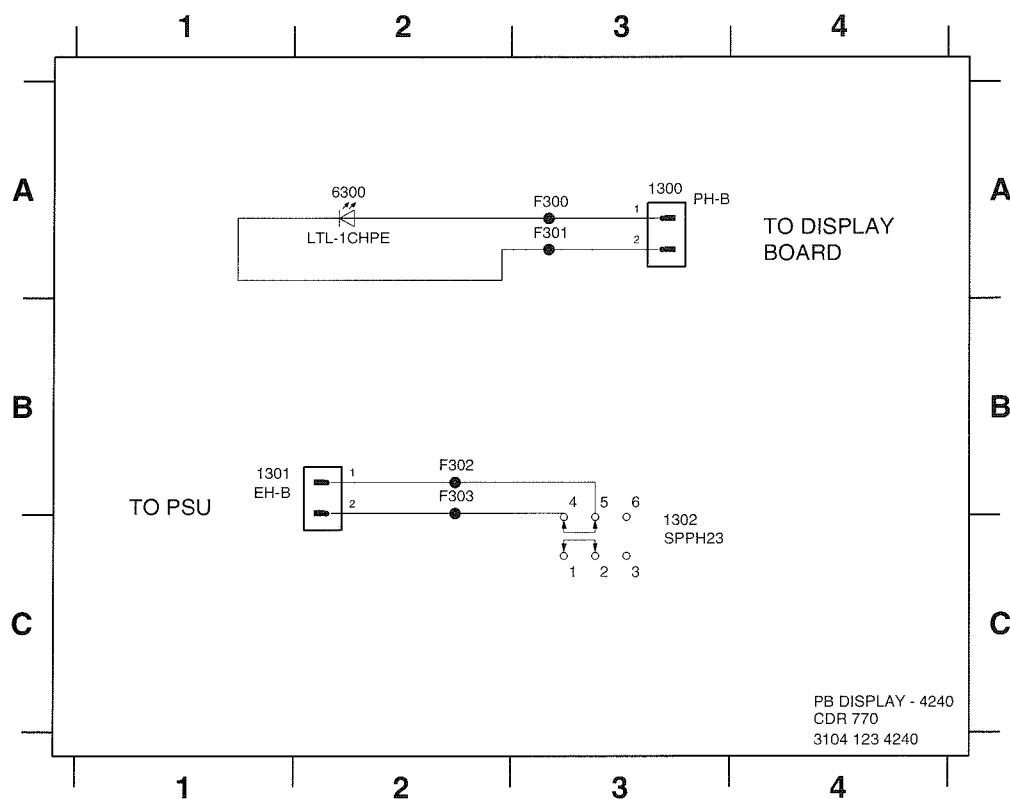

- 1300 A3
- 1301 B1
- 1302 C3
- 6300 A2
- F300 A3
- F301 A3
- F302 B2
- F303 B2

ON/OFF & STBY LED BOARD - FRONT VIEW



ON/OFF & STBY LED BOARD BACK VIEW



EXPLODED VIEW

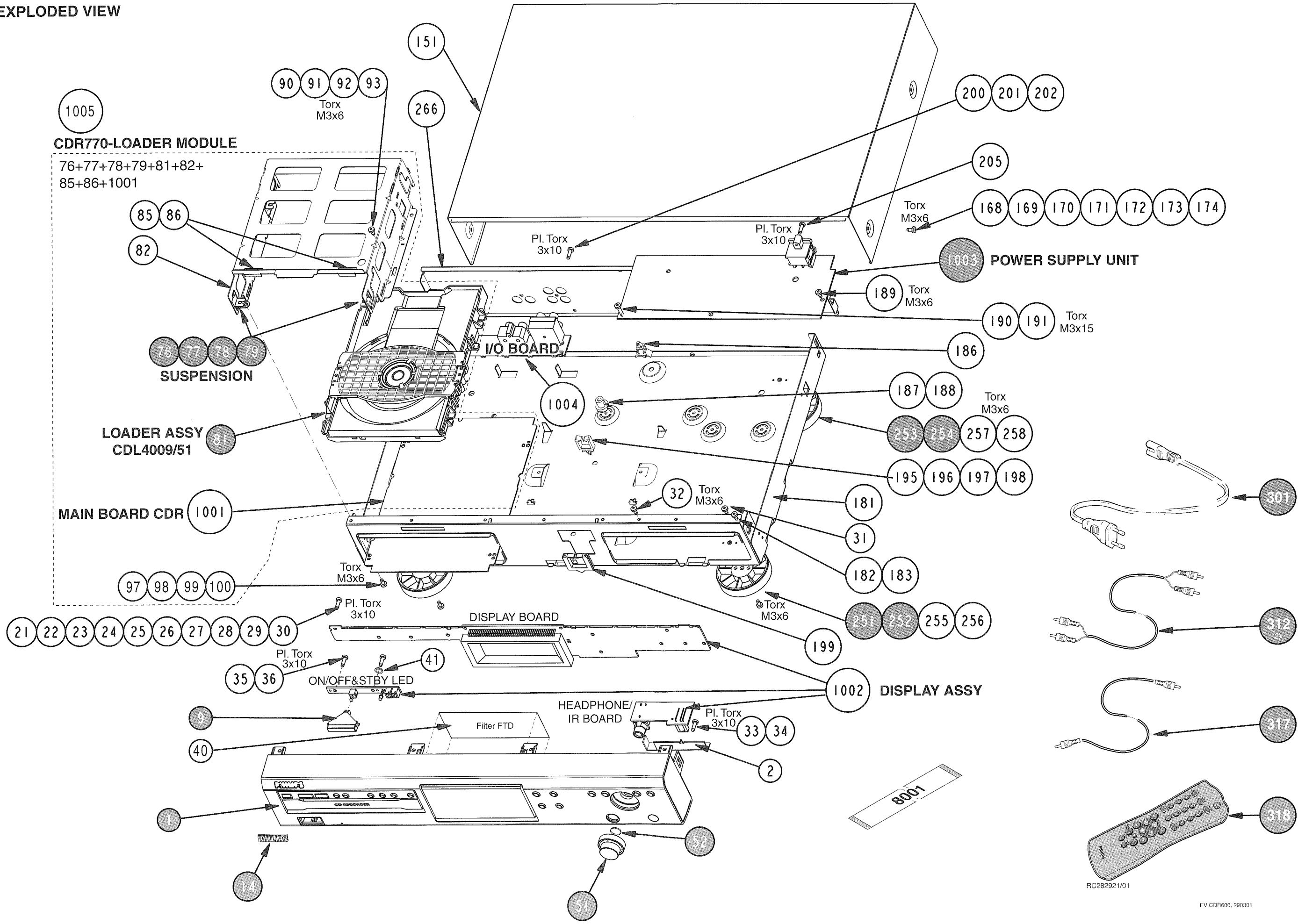

10. Partslist

10.1 Mechanical partslist

1	3103 308 11710	FRONT ASSY CDR600
1	3103 308 11720	FRONT ASSY CDR602
9	3103 304 71330	BUTTON POWER CDR600
9	3103 308 11290	BUTTON POWER CDR602
14	3139 240 00040	WORDMARK „PHILIPS“ SILVER CDR602
14	4822 459 10887	WORDMARK „PHILIPS“ CDR600
51	3103 304 71360	KNOB EASY-JOG CDR600
51	3103 308 11320	KNOB EASY-JOG CDR602
52	4822 492 51374	SPRING KNOB CLAMP
76	3104 144 05730	RUBBER DAMPER CD-DRIVE
77	3104 144 05730	RUBBER DAMPER CD-DRIVE
78	3104 144 05730	RUBBER DAMPER CD-DRIVE
79	3104 144 05730	RUBBER DAMPER CD-DRIVE
81	9305 043 20951	LOADER ASSY CDL4009/51
251	4822 462 11174	FOOT, SILVER
252	4822 462 11174	FOOT, SILVER
253	4822 462 42158	FOOT, BLACK
254	4822 462 42158	FOOT, BLACK
301	3104 128 92560	MAINS CORD, USA
301	4622 004 50290	MAINS CORD, IEC
312	3103 308 92610	AUDIO CABLE STEREO CINCH 1.5m
317	3103 308 92540	DIGITAL OUT CABLE, 75Ω
318	3139 228 82010	REMOTE CONTROL RC282921/01
1003	3122 427 22000	PSU-CDR3-ECO EURO 20PS202
1003	3122 427 22010	PSU CDR-3 ECONOMY USA
1005	3104 129 52521	CDR 770 MODULE SERVICE
8001	3104 157 11240	FLEXFOIL CABLE, 14P, 100mm

10.2 Electrical partslist

10.2.1. DISPLAY & HEADPHONE/IR BOARD

MECHANICAL PARTS

3	4822 256 10506	FTD HOLDER CDR600
---	----------------	-------------------

MISCELLANEOUS

1050	2422 129 16314	ROTATRY ENCODER + SWITCH
1101	4822 276 13114	TACT SWITCH
1102	4822 276 13114	TACT SWITCH
1103	4822 276 13114	TACT SWITCH
1104	4822 276 13114	TACT SWITCH
1105	4822 276 13114	TACT SWITCH
1106	4822 276 13114	TACT SWITCH
1107	4822 276 13114	TACT SWITCH
1108	4822 276 13114	TACT SWITCH
1109	4822 276 13114	TACT SWITCH
1111	4822 276 13114	TACT SWITCH
1112	4822 276 13114	TACT SWITCH
1113	2722 171 07174	DISPLAY CDR60x
1114	4822 276 13114	TACT SWITCH
1115	4822 276 13114	TACT SWITCH
1116	4822 276 13114	TACT SWITCH
1117	4822 276 13114	TACT SWITCH
1118	4822 276 13114	TACT SWITCH
1120	4822 276 13114	TACT SWITCH
1290	4822 267 31453	HEADPHONE SOCKET 6,3mm
1302	4822 276 14007	SWITCH PUSH, POWER
6200	4822 218 11745	TSOP1736, IR EYE

CAPACITORS

2100©	4822 126 14585	100nF	10%	50V
2101©	4822 126 13838	100nF	10%	50V
2102©	5322 122 32654	22nF	10%	63V
2104©	5322 122 32658	22pF	5%	50V
2106©	5322 122 32658	22pF	5%	50V
2109©	5322 122 32658	22pF	5%	50V
2110©	5322 122 32658	22pF	5%	50V
2111©	4822 126 14585	100nF	10%	50V
2200©	5322 122 31647	1nF	10%	63V
2201©	5322 122 31647	1nF	10%	63V

RESISTORS

3100©	4822 051 20472	4,7kΩ	5%	0,1W
3101©	4822 051 20472	4,7kΩ	5%	0,1W
3102©	4822 051 20472	4,7kΩ	5%	0,1W
3103©	4822 051 20472	4,7kΩ	5%	0,1W
3104©	4822 051 20472	4,7kΩ	5%	0,1W
3105©	4822 051 20472	4,7kΩ	5%	0,1W
3106©	4822 117 11149	82kΩ	1%	0,1W
3107©	4822 051 20472	4,7kΩ	5%	0,1W
3108©	4822 117 11373	100Ω	1%	0,1W
3109©	4822 117 11503	220Ω	5%	0,1W
3111©	4822 117 11373	100Ω	1%	0,1W
3112©	4822 051 20393	39kΩ	5%	0,1W
3113©	4822 117 10833	10kΩ	1%	0,1W
3114©	4822 117 10833	10kΩ	1%	0,1W
3122©	4822 117 11149	82kΩ	1%	0,1W
3124©	4822 117 11149	82kΩ	1%	0,1W
3125©	4822 051 20332	3,3kΩ	5%	0,1W
9000©	4822 051 20008	CHIP JUMPER 0805		
9001©	4822 051 20008	CHIP JUMPER 0805		
9002©	4822 051 20008	CHIP JUMPER 0805		
9003©	4822 051 20008	CHIP JUMPER 0805		

RESISTORS

9004 ©	4822 051 10008	CHIP JUMPER 1206
9005 ©	4822 051 10008	CHIP JUMPER 1206
9006 ©	4822 051 10008	CHIP JUMPER 1206
9007 ©	4822 051 10008	CHIP JUMPER 1206
9008 ©	4822 051 20008	CHIP JUMPER 0805
9009 ©	4822 051 20008	CHIP JUMPER 0805
9010 ©	4822 051 20008	CHIP JUMPER 0805
9011 ©	4822 051 20008	CHIP JUMPER 0805
9012 ©	4822 051 10008	CHIP JUMPER 1206
9013 ©	4822 051 10008	CHIP JUMPER 1206
9014 ©	4822 051 20008	CHIP JUMPER 0805
9015 ©	4822 051 20008	CHIP JUMPER 0805
9020 ©	4822 051 10008	CHIP JUMPER 1206
9021 ©	4822 051 10008	CHIP JUMPER 1206
9031 ©	4822 051 10008	CHIP JUMPER 1206
9034 ©	4822 051 20008	CHIP JUMPER 0805
9036 ©	4822 051 20008	CHIP JUMPER 0805
9037 ©	4822 051 10008	CHIP JUMPER 1206
9038 ©	4822 051 10008	CHIP JUMPER 1206
9039 ©	4822 051 10008	CHIP JUMPER 1206
9040 ©	4822 051 10008	CHIP JUMPER 1206
9041 ©	4822 051 20008	CHIP JUMPER 0805
9046 ©	4822 051 10008	CHIP JUMPER 1206
9048 ©	4822 051 20008	CHIP JUMPER 0805
9049 ©	4822 051 10008	CHIP JUMPER 1206
9050 ©	4822 051 10008	CHIP JUMPER 1206
9051 ©	4822 051 10008	CHIP JUMPER 1206
9052 ©	4822 051 10008	CHIP JUMPER 1206
9053 ©	4822 051 10008	CHIP JUMPER 1206
9054 ©	4822 051 10008	CHIP JUMPER 1206
9055 ©	4822 051 10008	CHIP JUMPER 1206
9056 ©	4822 051 10008	CHIP JUMPER 1206
9057 ©	4822 051 20008	CHIP JUMPER 0805
9058 ©	4822 051 20008	CHIP JUMPER 0805
9059 ©	4822 051 20008	CHIP JUMPER 0805
9060 ©	4822 051 20008	CHIP JUMPER 0805
9063 ©	4822 051 10008	CHIP JUMPER 1206
9064 ©	4822 051 10008	CHIP JUMPER 1206
9065 ©	4822 051 10008	CHIP JUMPER 1206
9066 ©	4822 051 20008	CHIP JUMPER 0805
9067 ©	4822 051 10008	CHIP JUMPER 1206
9068 ©	4822 051 10008	CHIP JUMPER 1206
9069 ©	4822 051 10008	CHIP JUMPER 1206
9071 ©	4822 051 20008	CHIP JUMPER 0805
9073 ©	4822 051 10008	CHIP JUMPER 1206
9075 ©	4822 051 10008	CHIP JUMPER 1206
9076 ©	4822 051 10008	CHIP JUMPER 1206
9077 ©	4822 051 10008	CHIP JUMPER 1206
9080 ©	4822 051 20008	CHIP JUMPER 0805
9081 ©	4822 051 10008	CHIP JUMPER 1206

COILS

1110	2422 540 98423	CERAMIC RESON. 8MHZ CSTS*MG03
------	----------------	-------------------------------

DIODES

6100 ©	9340 548 47115	PDZ3,3B
6300	4822 130 82978	LED LTL-16KPE

TRANSISTORS

7100 ©	4822 130 60511	BC847B
7203 ©	4822 130 60511	BC847B
7204 ©	4822 130 60511	BC847B
7999 ©	5322 130 60845	BC807-25

INTEGRATED CIRCUITS

7104	3104 123 94761	TMP87CH74F-6851, MICROPROC.
------	----------------	-----------------------------

10.2.2. I/O BOARD

MISCELLANEOUS

1000	2422 025 16289	FFC-CONNECTOR, 14P, SIDE ENTRY
1001	4822 267 31448	CINCH SOCKET, 2-FOLD
1002	4822 265 11151	CINCH SOCKET, 4-FOLD
6000	4822 218 11487	OPTICAL CONNECTOR, GP1F32R

CAPACITORS

2016 ©	4822 126 14585	100nF	10%	50V
2017 ©	5322 122 32654	22nF	10%	63V
2019	4822 124 40248	10µF	20%	63V
2020 ©	5322 122 32654	22nF	10%	63V
2021 ©	4822 126 12105	33nF	5%	63V
2022 ©	4822 126 12105	33nF	5%	63V
2023 ©	5322 122 32654	22nF	10%	63V
2024 ©	5322 122 32654	22nF	10%	63V
2025 ©	5322 122 33538	150pF	5%	63V
2026 ©	5322 122 32531	100pF	5%	50V
2027 ©	5322 122 32531	100pF	5%	50V
2028 ©	5322 122 32659	33pF	5%	50V
2029 ©	5322 122 32659	33pF	5%	50V
2030 ©	5322 122 32659	33pF	5%	50V

RESISTORS

2018 ©	4822 117 11139	1,5kΩ	1%	0,1W
3020 ©	4822 117 12521	68Ω	1%	0,1W
3021 ©	4822 051 20332	3,3kΩ	5%	0,1W
3024 ©	4822 051 20332	3,3kΩ	5%	0,1W
3026 ©	4822 051 20332	3,3kΩ	5%	0,1W
3027 ©	4822 051 20332	3,3kΩ	5%	0,1W
3028 ©	4822 117 11152	4,7Ω	5%	0,06W
3029 ©	4822 117 11927	75Ω	1%	
3032 ©	4822 117 11373	100Ω	1%	0,1W
3033 ©	4822 117 11373	100Ω	1%	0,1W
3034 ©	4822 117 11449	2,2kΩ	1%	0,1W
3035 ©	4822 117 11449	2,2kΩ	1%	0,1W
3036 ©	4822 117 11373	100Ω	1%	0,1W
3037 ©	4822 117 11373	100Ω	1%	0,1W
3038 ©	4822 117 11449	2,2kΩ	1%	0,1W
3039 ©	4822 117 11449	2,2kΩ	1%	0,1W
9001 ©	4822 051 20008	CHIP JUMPER 0805		
9002 ©	4822 051 20008	CHIP JUMPER 0805		
9003 ©	4822 051 10008	CHIP JUMPER 1206		
9004 ©	4822 051 20008	CHIP JUMPER 0805		
9005 ©	4822 051 10008	CHIP JUMPER 1206		

COILS

5001	4822 157 70601	100µH
5002 ©	4822 157 71206	COIL, BLM21

TRANSISTORS

7006 ©	4822 130 42615	BC817-40
7007 ©	4822 130 42615	BC817-40
7008 ©	4822 130 42615	BC817-40
7009 ©	4822 130 42615	BC817-40

INTEGRATED CIRCUITS

7005 ©	5322 209 11517	PC74HCU04T, HEX INVERTER IC
--------	----------------	-----------------------------

10.2.3. POWER SUPPLY BOARD

COMPLETE MODULES

1003	3122 427 22000	PSU-CDR3-ECO EURO 20PS202
1003	3122 427 22010	PSU CDR-3 ECONOMY USA

MECHANICAL PARTS

25	4822 492 63524	SPRING, FIXATION TRANSISTOR
60	4822 492 63524	SPRING, FIXATION TRANSISTOR

MISCELLANEOUS

101 ▲	4822 265 31015	MAINS SOCKET, IEC
101 ▲	4822 265 31016	MAINS SOCKET, USA
1120 ▲	4822 070 32002	FUSE T2A
1121	4822 265 11253	FUSE HOLDER 2P

CAPACITORS

2102 ©	2238 861 15182	1,8nF	5%	50V
2104 ©	5322 122 31647	1nF	10%	63V
2106 ©	5322 126 10223	4,7nF	10%	63V
2109 ©	5322 122 31863	330pF	5%	50V
2111 ©	4822 126 14585	100nF	10%	50V

2120 ▲	4822 121 10697	220nF	20%	275V
2121	8222 675 04990	220µF	10%	200V <i>USA version only</i>
2121	8222 675 05480	47µF	10%	400V <i>EU version only</i>
2127	4822 122 50116	470p	F10%	1kV
2128	4822 121 70141	33nF	5%	400V

2129	4822 124 40769	4,7µF	20%	100V
2131 ▲	4822 126 14497	2,2nF	20%	250V
2133	4822 124 42084	100µF	20%	35V
2134	4822 124 42084	100µF	20%	35V
2141	4822 124 22652	2,2µF	20%	50V

2142 ©	4822 126 14585	100nF	10%	50V
2150 ©	4822 126 14585	100nF	10%	50V
2161 ©	4822 126 14585	100nF	10%	50V
2201 ©	4822 126 14585	100nF	10%	50V
2202 ©	5322 122 32654	22nF	10%	63V

2210	2020 012 93728	2200µF	20%	10V
2213	4822 124 41584	100µF	20%	10V
2220	4822 124 40849	330µF	20%	16V
2221 ©	4822 126 13751	47nF	10%	50V
2222	4822 124 42234	100µF	20%	6,3V

2230	4822 124 81144	1000µF	20%	16V
2234	4822 124 81151	22µF	20%	50V
2240	4822 124 40196	220µF	20%	16V
2242	4822 124 41584	100µF	20%	10V
2250	4822 124 40255	100µF	20%	50V

2252	4822 124 40248	10µF	20%	63V
2253	2020 558 90449	4,7nF		1KV
2260 ©	4822 122 33177	10nF	20%	50V

RESISTORS

3102 ©	4822 117 10354	22kΩ	1%	0,1W
3103 ©	4822 051 20339	33Ω	5%	0,1W
3104 ©	4822 116 83933	15kΩ	1%	0,1W
3105 ©	4822 116 83933	15kΩ	1%	0,1W
3106 ©	4822 051 10102	1kΩ	2%	0,25W

3109 ©	4822 051 10102	1kΩ	2%	0,25W
3110	4822 050 21003	10kΩ	2%	0,25W
3111	4822 116 52199	68Ω	5%	0,16W
3112	4822 053 11229	22Ω	5%	2W
3113 ©	4822 051 10102	1kΩ	2%	0,25W

3117 ▲	4822 053 21684	680kΩ	5%	0,5W
3119 ▲	2322 595 90023	VDR 800V		
3123	4822 050 21803	18kΩ	1%	0,6W
3124	4822 117 12181	470Ω	20%	0,5W
3125 ©	4822 117 10833	10kΩ	1%	0,1W

RESISTORS

3126	4822 116 80176	1Ω	5%	0,5W
3127	4822 116 80176	1Ω	5%	0,5W
3128	4822 116 80676	1,5Ω	5%	0,5W
3129 ©	4822 117 10833	10kΩ	1%	0,1W
3134	4822 050 21803	18kΩ	1%	0,6W

3141 ©	4822 117 10833	10kΩ	1%	0,1W
3142 ©	4822 051 20109	10Ω	5%	0,1W
3150 ©	4822 117 11139	1,5kΩ	1%	0,1W
3151 ©	4822 117 11148	56kΩ	1%	0,1W
3201	4822 116 52176	10Ω	5%	0,5W

3202	4822 050 13302	3,3kΩ	1%	0,4W
3203	4822 116 52175	100Ω	5%	0,5W
3204 ©	4822 117 10833	10kΩ	1%	0,1W
3205 ©	4822 117 11503	220Ω	5%	0,1W
3206 ©	4822 051 20332	3,3kΩ	5%	0,1W

3207 ©	4822 051 10102	1kΩ	2%	0,25W
3208	4822 116 83883	470Ω	5%	0,16W
3221 ©	4822 051 20122	1,2kΩ	5%	0,1W
3222 ©	4822 051 20122	1,2kΩ	5%	0,1W
3223 ©	4822 117 11596	390Ω	1%	0,1W

3224	4822 116 52199	68Ω	5%	0,16W
3225	4822 116 52199	68Ω	5%	0,16W
3229 ©	4822 117 13085	5,6kΩ	1%	0,1W
3230	4822 050 21002	1kΩ	1%	0,6W
3232 ©	4822 117 11383	12kΩ	1%	0,1W

3233 ©	4822 051 20471	470Ω	5%	0,1W
3234 ©	4822 051 20332	3,3kΩ	5%	0,1W
3235	4822 116 52269	3,3kΩ	5%	0,5W
4101 ©	4822 051 20008	CHIP JUMPER		0805

COILS

5120	4822 157 11846	MAINS FILTER	<i>EU version only</i>
5121	4822 157 53348	MAINS FILTER	<i>USA version only</i>
5125	4822 157 11411	FERRITE BEAD	
5130	4822 157 51312	68µH	
5131	3128 138 38950	TRANSFORMER SMPS 20PS202	

5210	4822 157 11722	6,8µH	20%
5220	4822 157 51462	10µH	10%
5225	4822 157 53139	4,7µH	
5226	4822 157 53139	4,7µH	
5230	4822 157 50963	2,2µH	

5240	4822 157 51462	10µH	10%
5250	4822 157 51462	10µH	10%
5255	4822 157 51195	1µH	20%

DIODES

6100	4822 130 34281	BZX79-C15
6101	4822 130 34281	BZX79-C15
6102	4822 130 83707	S1NB80, BRIDGE RECTIFIER
6106	4822 130 31603	1N4006
6107	4822 130 31603	1N4006

6129 ©	5322 130 80122	BZX84-C24
6130 ©	4822 130 83649	1SS355
6132	4822 130 42488	BYD33D
6133 ©	4822 130 83649	1SS355
6141 ©	4822 130 10656	UDZ20B

6150 ©	4822 130 11148	UDZ-4,7B
6201 ©	9322 107 43685	UDZ-22B
6202 ©	9322 102 64685	UDZ-2,7B
6210	4822 130 83865	SB360
6220	4822 130 42488	BYD33D

6230	4822 130 11415	BYV28-400/20
6240	4822 130 42606	BYD33J
6250	4822 130 32896	BYD33M

TRANSISTORS

7125	4822 130 11417	STP3NB60FP, FET
7141 ©	4822 130 60373	BC856B
7150 ©	4822 130 60511	BC847B
7251	4822 130 41344	BC337-40
7252 ©	4822 130 60373	BC856B
7253	4822 130 41246	BC327-25
7254 ©	4822 130 60511	BC847B

INTEGRATED CIRCUITS

7110	9322 145 88682	UC3842A, PWM CONTROLLER
7131 ▲	4822 130 91451	CQY80NG, OPTO COUPLER
7201	4822 209 81397	TL431CLPST, PRECISION REFERENCE
7249	4822 209 82112	MC7908CT, VOLTAGE REGULATOR
7260	8222 675 06290	BA12T, VOLTAGE REGULATOR

PHILIPS

AUDIO CD RECORDER

MODEL

CDR-600/602

INSTRUCTION BOOK

Let's make things better.



PHILIPS

Caution

CAUTION: Use of controls or adjustments or performance of procedures other than herein may result in hazardous radiation exposure or other unsafe operation.

This product complies with the radio interference requirements of the European Union.

ATTENTION: L'utilisation des commandes ou réglages ou le non-respect des procédures ci-inclues peuvent se traduire par une exposition dangereuse à l'irradiation.

Ce matériel satisfait aux impératifs de brouillage radio de la Communauté Européenne.

ATENCIÓN: El uso de mandos o ajustes o la ejecución de métodos que no sean los aquí descritos puede ocasionar peligro de exposición a radiación.

Este aparato satisface las normas relativas a la interferencia radioeléctrica de la Comunidad Europea.

ACHTUNG: Der Gebrauch von Bedienelemente oder Einstellungen bzw. Verfahrensausführungen die hier nicht ausdrücklich erwähnt worden sind, kann eine gefährliche Strahlendosierung oder andere unsichere Operationen zur Folge haben.

Dieses Produkt entspricht den Funkentstörvorschriften der Europäischen Union.

LET OP: Het gebruik van de toetsen en regelingen of het toepassen van de aanwijzingen anders dan hier beschreven, kan leiden tot blootstelling aan gevaarlijke straling of tot onveilige werking. Dit apparaat voldoet aan de radio-ontstoringseisen van de Europese Unie.

ATTENZIONE: L'uso dei comandi o regolazioni o prestazioni delle procedure oltre a quelle descritte nel presente potrebbero causare esposizione a radiazioni pericolose o altre operazioni rischiose.

Questo prodotto è conforme ai requisiti delle interferenze radio della Unione Europea.

WARNING: Om du använder knapparna på annat än här angivet sätt eller utför andra justeringar eller förfaranden än de här angivna kan du utsättas för skadlig strålning eller andra risker.

Denna apparat uppfyller EU:s krav beträffande radiostörningar.

ADVARSEL: Anvendelse af andre betjeningsanordninger eller justeringer eller udførelse af andre procedurer end de heri angivne, kan medføre udsættelse for farlig stråling eller andre risici.

Dette apparat overholder EU's krav vedrørende radiostøj.

MUISTUTUS: Muiden kuin tässä kuvattujen säätimien tai säätöjen tai toimenpiteiden käyttö voi aiheuttaa vaarallisen altistuksen säteilylle tai muun turvallisuutta vaarantavan seurauksen.

Tämä tuote on Euroopan unionin radiohäiriöitä koskevien vaatimusten mukainen.

AVISO: A utilização de comandos ou ajustes ou a execução de procedimentos de forma diferente daquela aqui indicada poderá resultar numa exposição perigosa a radiações ou noutra operação arriscada.

Este produto obedece aos requisitos referentes a interferência de rádio estabelecidos pela União Europeia.

ΠΡΟΣΟΧΗ: Οποιαδήποτε διαδικασία, χρήση ή ρύθμιση των ρυθμιστικών πλήκτρων και διακοπών εκτός των προβλεπόμενων στο παρόν εγχειρίδιο, μπορεί να έχει ως αποτέλεσμα την επιβλαβή έκθεση σε ακτινοβολία ή άλλη επικίνδυνη λειτουργία.

Υο προϊόν αυτό πληροί τις απαιτήσεις της Ευρωπαϊκής Ένωσης ως προς τις ραδιοπαρεμβολές.

UWAGA: Operowanie klawiszami lub pokrętłami w sposób odbiegający od zalecanego albo wykonywanie procedur innych, niż zawarte w niniejszej instrukcji, może narazić użytkownika na niebezpieczne promieniowanie lub inne zagrożenia.

Niniejszy produkt spełnia wymogi Unii Europejskiej dotyczące zakłóceń radiowych.

English ————— **4**

Table of contents

English

General information	
Welcome.....	5
Environmental information.....	5
About this manual.....	5
Technical data.....	5
Discs for recording.....	6
Discs for playback.....	6
Maintenance.....	6
Accessories.....	6

Operating buttons	
Controls.....	7

Display	
DISPLAY indications.....	8
DISPLAY messages.....	8
MENU messages.....	10

Connections	
Connections at the back.....	11
Set up recommendations.....	11
Connections general.....	11

Installation	
Analog connections.....	12
Digital connections.....	12
Power supply/Mains.....	13

Remote control	
Inserting batteries in the remote control.....	14
Remote control commands.....	14

Recording	
Inserting discs.....	15
Introduction.....	16
Adjusting the recording level.....	17
Recording an entire CD.....	17
Recording a single track.....	18
Manual recording.....	19
Finalizing CDR & CDRW discs.....	20
Unfinalizing CDRW discs.....	20
Erasing CDRW discs content.....	21

Playing	
Playing a CD.....	21
Selecting a track.....	21
Search.....	22
Shuffle (random order) play.....	22
Repeat CD, track or program.....	22
Programming tracks.....	22

Menu mode	
Remarks about Menu mode.....	23
General operation of Menu.....	23
A. Text input.....	24
B. Erasing text.....	24
C. Reviewing CD text memory.....	25
D. Auto track increment.....	25
E. Balance.....	26

Troubleshooting	
Troubleshooting.....	27

General information

Welcome!

Thank you for buying this Philips Compact Disc Recorder.

In the 1980s Philips invented a new audio system - the CD. The CD (compact disc) revealed the new dimensions of digital sound and added to the pleasure of audio.

Compact-disc technology permits a high contrast in both loud and soft passages, with perfect channel separation.

Philips has now further developed compact disc technology and the result is the CD recorder.

With your Philips CD Recordable/ReWritable Recorder, you can record, play and erase your own high-quality audio CDs, subject to legal restrictions on copying. Naturally, you will also be able to play all pre-recorded audio CDs.

Note: In certain countries, including the UK and certain Commonwealth countries, use of the product (or CD Recorder) as shown or suggested in this user manual may require the permission of copyright holders.

Environmental information

All redundant packing material has been omitted. We have done our utmost to make the packaging easily separable into three mono materials: cardboard (box), polystyrene foam (buffer) and polyethylene (bags, protective foam sheet).

Your set consists of materials which can be recycled if disassembled by a specialized company. Please observe the local regulations regarding the disposal of packing materials, exhausted batteries and old equipment.

CAUTION

INVISIBLE RADIATION WHEN OPEN.
AVOID EXPOSURE TO BEAM.

Note: This warning is located inside the enclosure.

About this manual

This manual gives instructions for operating this CD recorder.

Please note:

- the digits (1) throughout the text indicate a sequence of actions necessary to perform a certain operation;
- the arrows (→) indicate the reaction from the recorder;
- the dots (○) indicate remarks, advice or special options within a sequence of actions. The dot-marked instructions are not necessary for operation.

All instructions in this manual are based on control via the keys on the set. If there are corresponding keys available on the remote control they can be used as well.

Technical data

Subject to modification without notice.

General

Power consumption.....	15 W
Power consumption in Standby.....	6 W
Operating temperature.....	5-35° C
Weight.....	4 kg
Dimensions.....	435 x 310 x 88 mm

Audio

Frequency response.....	2Hz-22.050 Hz
Playback S/N (A-weighted).....	100 dB
Playback S/N.....	100 dB
Playback dynamic range CDR.....	95 dB
Playback total harmonic distortion CDR.....	88 dB = 0.0039 %
Channel separation.....	100 dB
Recording S/N (A-weighted).....	98 dB
Recording S/N digital without SRC.....	equal to source
Recording dynamic range.....	92 dB
Recording total harmonic distortion - noise.....	85 dB (0.0056%)

Laser

Type.....	Semiconductor laser GaAlAs
Wave length.....	775-795 nm (at 25° C)
Output power.....	2.5 mW (Read.) 35 mW (Write)
Beam divergence.....	60 degree

The type plate is located on the back of the set.

General information

Discs for recording

For recording, make sure to use special audio discs only. These discs are marked with "Digital Audio" and the logos shown below.

There are two different types of audio discs for the use on this CD recorder:

- CD-Audio Recordable (CDR) discs

These discs can be recorded on once and play in all standard CD players and CD recorders, when they are finalized.



- CD-Audio ReWritable (CDRW) discs

These discs can be recorded on, erased and re-recorded many times and play in CDRW compatible CD players and CD recorders, when they are finalized.



All Philips CD players and CD recorders with the sticker shown here are CDRW compatible.



To ensure proper working of the set we recommend the use of Philips audio CDR and audio CDRW discs only.

Note: Do not use a computer CDR or CDRW as recording will not work!

Recording is permissible insofar as copyright or other rights of third parties are not infringed upon.

In certain countries including the UK and certain Commonwealth countries, use of the product as shown or suggested in this user manual may require the permission of copyright holders.

Discs for playback

Your CD recorder is able to play:

- All pre-recorded audio CDs.
- All Audio CDR and Audio CDRW.

Note: CDR(W) discs containing audio recorded with a computer can only be played when they are correctly treated according the audio standard (IEC958: Consumer part). Single session only!

Maintenance

For recording, it is very important to use discs that are free of dust and scratches.

To clean a CD, wipe it in a straight line from the center towards the edge using a soft, lint-free cloth. A cleaning agent may damage the disc! Write only on the printed side of a CDR or CDRW, and only with a soft felt-tipped pen.

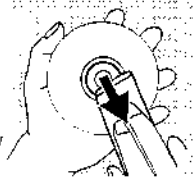

Clean the CD recorder with a soft, slightly dampened lint-free cloth. Do not use any cleaning agents as they may have a corrosive effect.



Do not expose the CD recorder batteries or CDs to humidity, rain, sand or excessive heat (caused by heating equipment or direct sunlight).

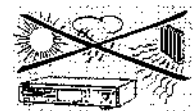

Always keep the tray closed to avoid dust on the lens.

The lens may cloud over when the CD recorder is suddenly moved from cold to warm surroundings, making it impossible to play a CD. Leave the CD recorder in the warm environment until the moisture evaporates.

Accessories

- 2 Analog audio cables (with red and white plugs)
- 1 Digital coaxial cable (with black plugs)
- Power cord
- 2 Batteries
- Remote control
- Guarantee

Operating buttons

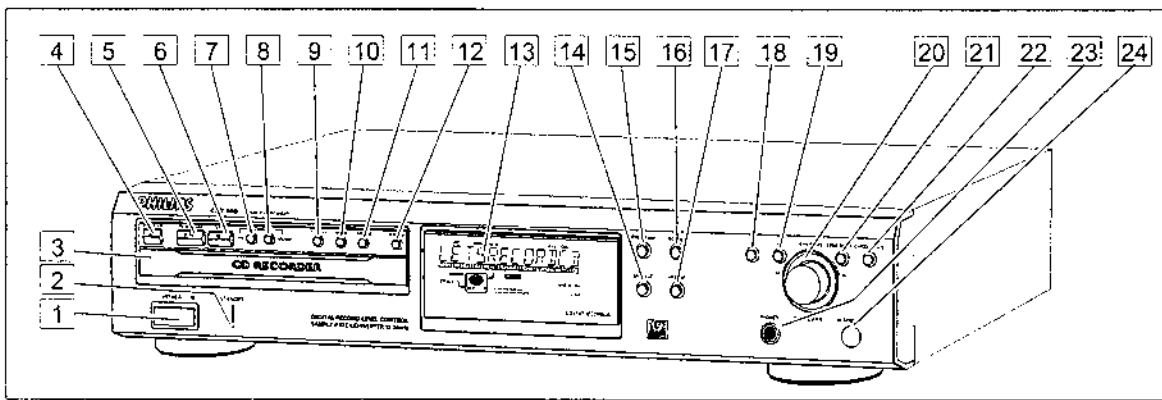





Controls

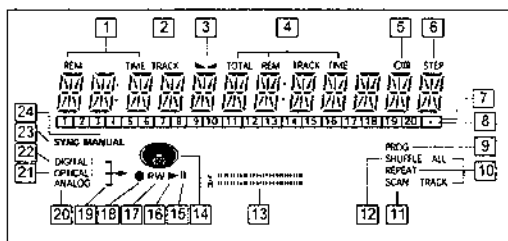

- 1 ON/OFF**
turns the CD recorder ON and OFF
- 2 Standby indicator**
- 3 Disc tray**
- 4 OPEN/CLOSE ▲**
opens/closes disc tray
- 5 PLAY/PAUSE ►||**
starts play/interrupts play or recording
- 6 STOP ■**
stops/clears a program
- 7 RECORDING TYPE**
selects recording modes
- 8 RECORD**
starts recording, finalizing, erasing
- 9 FINALIZE**
selects finalize mode
- 10 ERASE**
selects erasing mode (disc or track)
- 11 SOURCE**
selects input source
- 12 DISPLAY**
selects display information, permanent text scrolling and time
- 13 Display information screen**
- 14 SHUFFLE**
plays CD(RW) or program in random order
- 15 PROGRAM**
opens/closes program memory
- 16 SCROLL**
activates scrolling of text over the display (once)
- 17 REPEAT**
repeats play (all, program or track)
- 18 ◀◀**
- searches backward
- cursor control in Menu/Prog. review mode
- 19 ▶▶**
- searches forward
- cursor control in Menu/Prog. review mode
- 20 ◀ EASY JOG ▶ (rotate)**
- previous/next track (Play and Program mode)
- recording level control (recording)
- selects settings (menu on)
- ENTER (push)**
- plays selected tracks
- selects settings in menu mode
- programs track numbers
- 21 STORE/MENU**
- enters Menu mode
- stores Menu settings
- 22 CANCEL/DELETE**
- deletes tracks from a program
- deletes text in Menu mode
- returns to a higher level in the menu
- 23 PHONES**
socket for headphones
- 24 IR sensor**
receives signals from the remote control

Display

DISPLAY indications



- 1 **REMTIME**
remaining time
- 2 **TRACK**
track number
- 3 
balance (lights up during balance adjustment)
- 4 **TOTAL REM TRACK TIME**
indicates total or remaining time of disc or track
- 5 
remote control active
- 6 **STEP**
indicates the number of tracks in a program
- 7 **Track bar**
indicates:
- tracks on a disc or in a program
- track in play
- 8 **+ 20**
disc or program contains more than 20 tracks
- 9 **PROG (ram)**
flashes during programming/lights in program mode
- 10 **REPEAT TRACK/ALL**
lights up when a track/complete disc (or program) is repeated
- 11 **SCAN**
lights up when the first 10 seconds of each track are played
- 12 **SHUFFLE**
plays tracks in random order
- 13 **L/R II II**
Record/play level bar, indicates the audio signal level
- 14 **CD**
CD inserted (a pre-recorded CD or finalized CDR or CDR(W) disc)
- 15 **II**
pause function active
- 16 
lights during play
- 17 **R(W)**
unfinalized CDR(W) disc inserted

- 18 
lights during recording
- 19 
lights during recording
- 20 **ANALOG**
analog input selected
- 21 **OPTICAL I**
optical input I selected for external recording
- 22 **DIGITAL I**
digital input I selected for external recording
- 23 **SYNC**
synchronized recording active
- 24 **MANUAL**
manual recording active

DISPLAY messages

Messages as listed and explained here may appear on the display for your guidance.

General

- READING**
reading disc information
- OPEN**
opening tray
- CLOSE**
closing tray
- NO DISC**
no disc inserted, disc unreadable or disc inserted upside down
- PROG FULL**
program full
- INSERT DISC**
insert disc or insert disc correctly
- WRONG DISC**
inserted disc is not an audio CD
- UNFINALIZED**
unfinalized CDR(W) disc
- MEMORY XXX%**
indicates the amount of memory used for unfinalized discs

Recording

- WAIT**
- when STOP ■ is pressed during recording
- when STOP ■ is pressed during recording the first 4 seconds of a track
- UPDATE**
updating disc contents

BISC FULL
recording no longer possible

DIGITAL 1
digital coaxial input 1 selected

OPTICAL
digital optical input selected

ANALOG
analog input selected

COPY PROTECT
no digital recording can be made from the connected source

NOT FINALIZED
when opening the tray with an unfinalized disc inserted

MAKE CD
start of synchronized recording of a complete disc and Auto Finalize function selected

RECORD DISC
start synchronized recording of a complete disc

RECORD TRACK
start synchronized recording of a single track

REC MANUAL
manual start of recording selected

***** BB**
level is being adjusted

ERASE TRACK
when erasing one or more tracks

ERASE DISC
when erasing a disc

FINALIZE CD
when finalizing a disc

FINALIZED
when trying to finalize an already finalized disc

CHECK INPUT
when RECORD is pressed while no digital source is detected

***** ERASE**
time countdown when erasing a track or a disc

***** FINAL**
time countdown when finalizing a disc

PRESS RECORD
to start manual recording, finalizing or erasing

START SOURCE
to start synchronized recording from a source (e.g. CD player)

FINALIZED CD
when trying to record on a finalized CDR or a prerecorded CD

UNFINALIZE/PRESS ENTER
when trying to record on a finalized CDRW

PROF SOURCE
when a professional source is connected

Play

PROGRAM
program mode selected

ALBUM TITLE
will be followed by album title

TRACK TITLE
will be followed by track title

ALBUM ARTIST
will be followed by artist's name

TRACK ARTIST
will be followed by track artist's name

Others

NO AUDIO TR
when the recorder enters a data track during recording

FINALIZE CD
laser power calibration performed 96 times, finalize disc needed

INITIALIZING
during laser power calibration for unfinalized discs

DISC RECOVER
during disc recovery after power failure

OPC ERROR
OPC failure during OPC procedure (OPC = Optimum Power Calibration)

RECORD ERROR
recording error in menu mode

DISC ERROR
when trying to record on or finalize a recovered disc

MEMORY FULL/FINALIZE CD
when no more text can be stored for a certain disc. Another disc must be finalized to obtain memory space

NOT POSSIBLE
when trying to erase a CDR

Display

English

MENU messages - See Menu mode

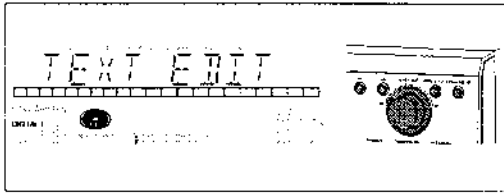

- NO TRACKS
when attempting to edit text for a disc which has no tracks
- TEXT EDIT
when entering Text Edit mode
- ALBUM ARTIST
when editing or erasing an artist's name
- ALBUM TITLE
when editing or erasing a title
- ARTIST TR N
when editing or erasing an artist's name per track
- TITLE TR N
when editing or erasing a title per track
- TEXT ERASE
when entering Text Erase mode
- ALL TEXT
when entering AllText mode
- ERASE OK
when confirmation for erasing must be given with ENTER key
- ERASE ALL OK
when confirmation for erasing must be given with ENTER key
- ERASE MEMORY
when waiting for confirmation for erasing a disc
- MEMORY VIEW
when selecting text review per unfinalized disc in memory
- MEMORY EMPTY
when REVIEW is selected while no text is in memory

- AUTO TRACK
when selecting auto track increment ON or OFF
- ON
Auto Track increment on
- OFF
Auto Track increment off
- SET BALANCE
when selecting BALANCE
- NO TEXT
no text stored for disc

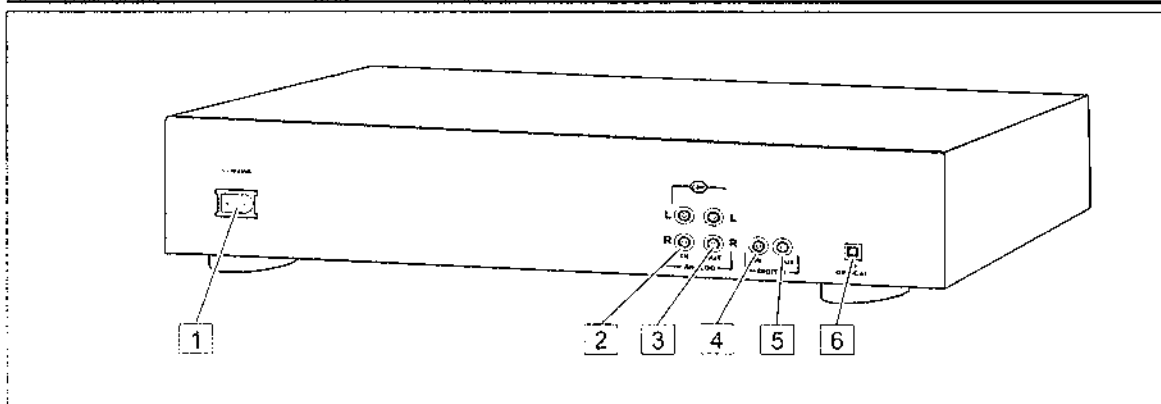

Connections at the back

- 1 Connection to mains
- 2 **ANALOG IN**
connects to the line (analog) output of an amplifier/receiver or other analog source (tape deck, tuner etc.), so you can record from this source (ANALOG IN). For recording from a record player both recorder and record player should be connected to an amplifier/receiver
- 3 **ANALOG OUT**
connects to the line (analog) input of an amplifier/receiver, so you can listen to playback of this set via the amplifier/receiver
- 4 **DIGITAL IN**
connects to the digital coaxial output of an external digital source (CD player, DVD, DAT, etc.), so you can record from this source (DIGITAL IN)
- 5 **DIGITAL OUT**
connects to the digital coaxial input of an amplifier/receiver, so you can listen to playback of this set via the amplifier/receiver
- 6 **OPTICAL IN**
connects to the digital optical output of an external digital source (CD player, DVD, DAT, etc.), so you can record from this source (OPTICAL IN)

Connections general

For recording the following inputs are present:

- Digital optical input (OPTICAL IN)
- Digital coaxial input (DIGITAL IN)
- Analog input (ANALOG IN)

For playback the following outputs are present:

- Digital coaxial output (DIGITAL OUT)
- Analog output (ANALOG OUT)

The connections you make will depend upon the possibilities your audio equipment offers. Please refer to the user manuals for your other audio equipment first.

Digital recordings (optical or coaxial) give the best performance in audio and usability (e.g. auto-track increment).

We advise you to always establish both digital and analog connections. This will mean that analog recordings can always be made when digital recording is not possible.

We have described the most common ways of connecting the CD recorder. If you still have difficulties with the connections, please contact the Philips Consumer Service desk in your area.

Set up recommendations

- Place the CD recorder on a solid, vibration-free surface.
- Do not place the CD recorder near a source of heat or in direct sunlight.
- Do not use the CD recorder under extremely damp conditions.
- If the CD recorder is placed in a cabinet, make sure that a one-inch space remains free on all sides of the CD recorder/player for proper ventilation.

Important: Do not position the CD recorder on top of other equipment that might heat it up (e.g. receiver or amplifier).

Installation

English

Analog connections

These connections are required for playback and recording via an amplifier/receiver, equipped with an analog in- and outputs.

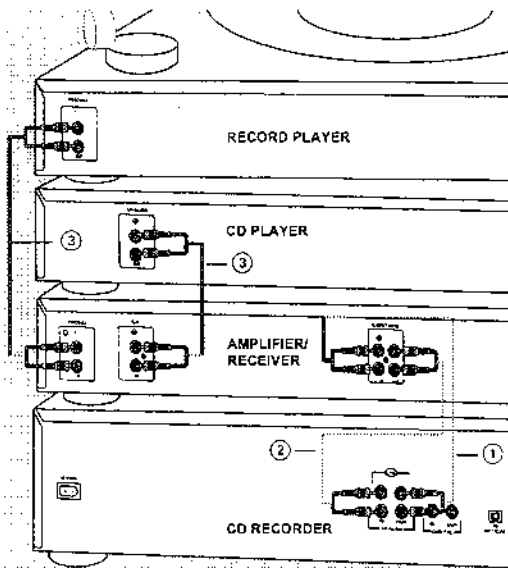

- 1 Connect supplied audio cable between the ANALOG OUT-sockets on the set and the ANALOG input sockets of the amplifier/receiver (TAPE IN, CD-R, AUX or PLAY IN). Insert the red plugs into the R sockets, and the white plugs into the L sockets.
- 2 Connect supplied audio cable between the ANALOG IN-sockets on the set and the analog outputs of the amplifier/receiver (CDR OUT, TAPE OUT, AUX OUT, REC OUT etc.). Insert the red plugs into the R sockets, and the white plugs into the L sockets.
- 3 Connect all other components of your system (tape deck, CD player, tuner, record player etc.) via their ANALOG OUT-sockets to the appropriate analog input sockets of the amplifier/receiver (CD IN, TUNER IN, AUX IN, PHONO IN etc.).
→ Any analog device, connected to the amplifier/receiver can now be used as recording source (ANALOG).

Digital connections

Direct digital coaxial connection

This connection is required for direct recording from a digital coaxial source (e.g. a CD player, DVD, DAT).

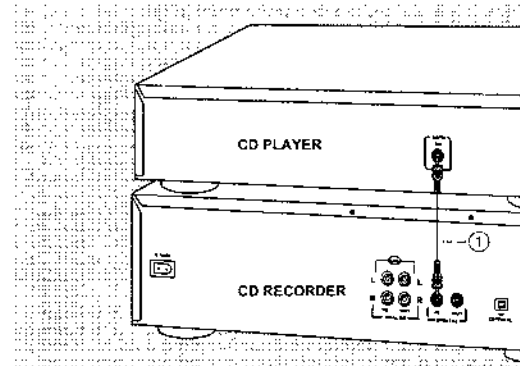

- 1 Connect a digital coaxial cable between the DIGITAL IN-socket on the set and the DIGITAL OUT socket of the digital source.
→ Recording can now be done via the digital coaxial input (DIGITAL 1).

Direct digital optical connection

This connection is required for direct recording from a digital optical source (e.g. a CD player, DVD, DAT).

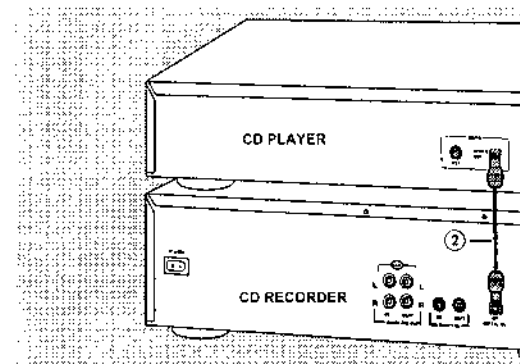

- 1 Remove the dust caps from the digital optical connections of both source and CD recorder. Keep the caps in a safe place.
- 2 Connect an optical fibre-optic cable between the OPTICAL IN socket of the set and the OPTICAL OUT socket of the source. Make sure you insert both plugs fully, until a click is heard.
→ Recording can now be done via the digital optical input (OPTICAL).

Digital coaxial connections via a digital receiver

If you have a receiver with digital coaxial in- and outputs, these connections allow you to make digital recordings from various sources, connected to the receiver.

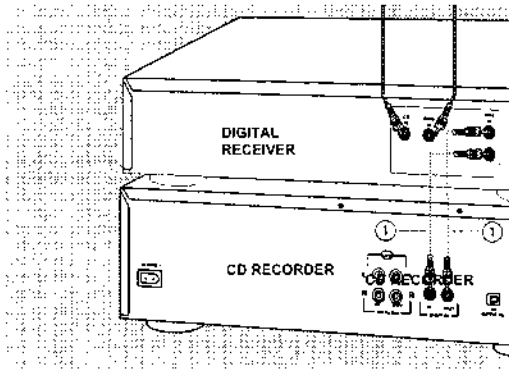

- 1 Connect a digital coaxial cable between the DIGITAL IN- and OUT sockets on the set and e.g. the (digital) AUX in- and output sockets on the digital receiver.
→ Any digital device, connected to the digital input sockets of the digital receiver (e.g. CD and DVD) can now be used as recording source.

Power supply/Mains

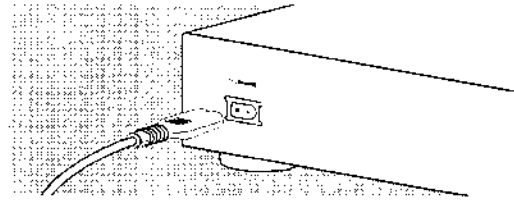

- 1 Check whether the mains voltage as shown on the type plate corresponds to your local mains voltage. If it does not, consult your dealer or service organisation.
- 2 Make sure all connections have been made before switching on the mains supply.
- 3 Plug the power cord supplied into the AC MAINS – connector and the CD recorder, then into the wall socket.
- 4 Press ON/OFF.
→ The CD recorder will switch on.

Notes:

If the CD recorder is in Standby mode (red LED on), press any key to activate the recorder.

When the CD recorder is in the "OFF" position, it is still consuming some power. If you wish to disconnect your CD recorder completely from the mains, withdraw the plug from the AC Outlet.

Remote control

English

Inserting batteries in the remote control

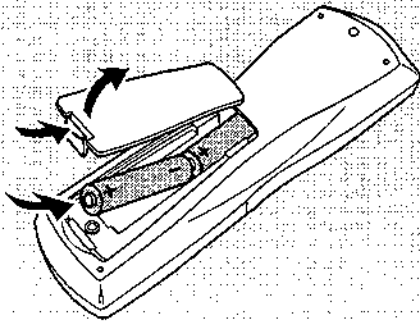

- 1 Open the battery compartment cover.
- 2 Insert 2 batteries (AA, LR6 or UM-3; as supplied) as shown.
- 3 Replace the cover.

Note: We recommend you use 2 batteries of the same type and condition.

Batteries contain chemical substances, so they should be disposed of properly.

Remote control commands

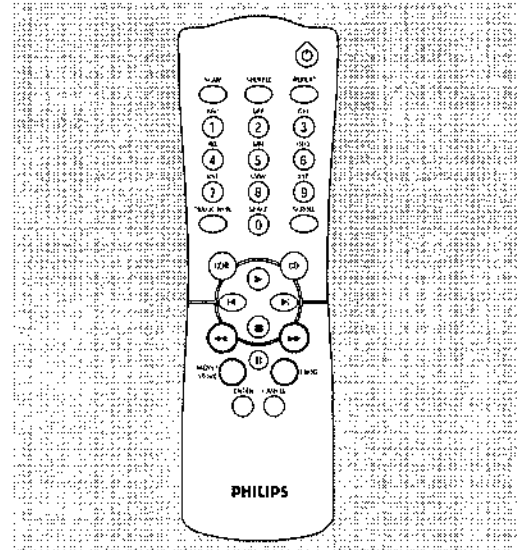

STANDBY

switches to Standby/On/Off

SCAN

plays the first 10 seconds of each track

SHUFFLE

plays CD(RW) or program in random order

REPEAT

repeat play

Number/alphabet keys 0 - 9

- selects a track by number
- selects character for text input

TRACK INCR(ement)

increases track numbers during recording

SCROLL

activates scrolling of text over the display

CDR

selects CD recorder

CD

selects CD player, can be used to control a separate Philips CD player



starts CD(RW) play



previous track (Play and Program mode)



next track (Play and Program mode)



stops CD(RW) and clears a program



- searches backward
- cursor control in Menu/Prog. review mode



- searches forward
- cursor control in Menu/Prog. review mode



interrupts CD(RW) play/recording

MENU/STORE

- enters Menu mode
- stores Menu settings

PROG.(ram)

opens/closes program memory

ENTER

- selects settings in Menu mode
- programs track numbers
- starts playback of selected track

CANCEL

- deletes tracks from a program
- deletes text in Menu mode
- returns to a higher level in the menu

Note: Always press CDR first to select the CD recorder.

Inserting discs

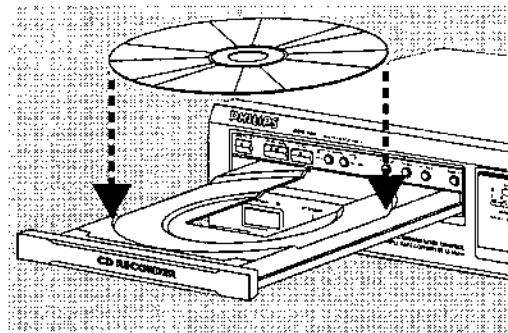

- 1 Press OPEN/CLOSE to open the disc tray.
→ OPEN lights up.
 - 2 Insert a CD, CDR or CDRW in the appropriate recess in the tray, label side up.
 - 3 Press OPEN/CLOSE to close the tray (see also Playing a CD).
→ CLOSE lights up, followed by RECORDING the display will show the type of disc that has been inserted.
- If a blank or partly-recorded CDR or unfinalized CDRW is inserted, the CD recorder will calibrate the disc for optimum recording. During this process the display will first show INITIAL TIME and then the number of audio tracks. Calibration can take up to 25 seconds.
 - If a CDR(W) is finalized, CD will show on the display.
 - If CD-text is available the TITLE/TEXT will scroll by.

Notes:

Only Audio CDs will be accepted. If a non-audio disc is inserted, the display will show: WRONG DISC / USE AUDIO CD.

For recording it is important that the blank disc is completely free from dust particles or scratches (see maintenance).

Recording

Introduction

You will soon discover how easy it is to make your own CDs.

Your recorder offers several recording modes.

RECORD DISC

- to make a synchronized recording of the complete disc or a program simply by starting the source.

RECORD TRACK

- to make an synchronized recording of a single track simply by starting the source.

REC(ord) MANUAL

- to manually start a recording simply by pressing the RECORD key.

MAKE CD

- to make a synchronized recording of the complete disc or a program simply by starting the source. Finalizing will be done automatically (active for digital recordings).

For each recording purpose the most appropriate recording mode is explained. Basically a recording session consists of three steps:

- preparing (make all settings for your recording),
- recording (the actual recording starts) and
- finalizing your recording (making CDR(W) suitable for playback on a standard cd-player).

Some remarks on recording

It is advisable to use a CDRW disc for your first try.

- If the disc is a CDR disc and is already finalized, no recording is possible.
- If the disc is a CDRW disc and is already finalized, you must unfinalize it first.
- The recording procedure is the same for CDRs and CDRWs.
- CD text cannot be recorded from an external CD player. (Text information is not available on the output of the CD player.)

- There must be at least 7 seconds of recording time left on the disc, otherwise you will not be able to enter record standby mode. **BISC FULL** will then show on the display.
- If the display indicates **CD's PROTECT** no digital recording can be made of the source material. Recording will not start.
- The Serial Copy Management System (SCMS) only allows digital recording under specific conditions:
 - This means that it is not possible to make a digital copy from a digital copy.
 - Analog recording is always possible!
 - The number of recordings to be made from the original is unlimited.
- A maximum of 99 tracks can be recorded on a disc. Minimum allowable track length is 4 seconds.

Important: Use only discs with CDR AUDIO only or CDRW AUDIO only logo. Discs for use in a personal computer's CD-(re)writer cannot be used in an Audio CD-recorder.

If you want to play the recorded CDR disc on a regular CD player, it must be finalized.

Finalizing is a simple procedure, necessary to:

- **be able to play recordings on a CD PLAYER,**
- **avoid further unwanted recordings on a disc,**
- **avoid erasure of tracks on a CDRW,**
- **write CD text on a CDR(W).**

Finalized CDRW discs play only on CDRW compatible CD players.

Adjusting the recording level

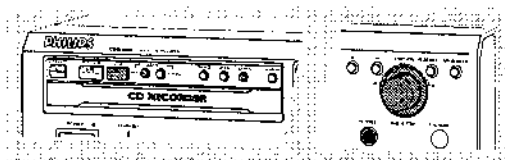

Some analog sources have such high output levels, that you may need to adjust the recording level to ensure good quality recordings without distortion.

- 1 Place an unfinalized CD(RW) disc, absolutely free of scratches and dust particles in the CD recorder tray.
- 2 Press SOURCE repeatedly to select the ANALOG input
→ ANALOG lights up and ANALOG will appear on the display.
- 3 With the CD recorder stopped, press RECORDING TYPE three times to select REC MANUAL.
→ starts to flash and the display shows PRESS RECORD.
- 4 Start the source by pressing PLAY/PAUSE .
DO NOT start recording!
- 5 Rotate the EASY JOG/ENTER key to decrease the record level: until, on the Record/Play Level bar, all the blue segments are alight, but the red segments do not light continuously during the loudest passages.
- 6 Press STOP on the CD recorder and on the source.
→ The adjusted recording level is stored in the memory of your recorder (also when powered off).

Note: The recording level can also be adjusted for digital or optical recordings after selecting the DIGITAL 1 or OPTICAL input.

Recording an entire CD

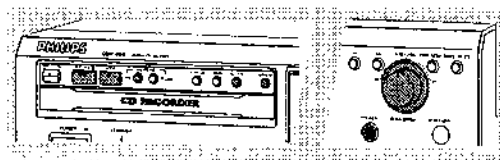

This feature enables you to make fast and easy copy of an entire CD to CD, make a compilation CD or archive an entire LP or cassette on CD.

Preparing

- 1 Place an unfinalized recordable disc, absolutely free of scratches and dust particles in the CD recorder tray.
- 2 Press SOURCE repeatedly to select the type of connection you made to your source of recording. Examples:
 - CD-player is connected with its digital out connector directly to the digital in connector of your CD-recorder: connection is DIGITAL 1.
 - CD-player is connected with its analog out connectors directly to analog in connectors of your CD-recorder: connection is ANALOG
 - Turntable is connected with its analog out connectors to amplifier/receiver which is connected to the analog in connectors of your CD-recorder: connection is ANALOG
 → DIGITAL 1, OPTICAL 1 or ANALOG lights up and DIGITAL 1, OPTICAL 1 or ANALOG will appear on the display.
- 3 With the CD recorder stopped, press RECORDING TYPE to select REC DISC for recording of an entire CD or a program of tracks.
→ and sync start to flash and the display shows the selection.
If the input label DIGITAL 1 or OPTICAL 1 also flashes, switch on the external source or check the digital connection.

Notes:

If you are recording from a digital source (OPTICAL or DIGITAL 1) and want to finalize the CD automatically after recording, press RECORDING TYPE until the option MAKE CD is selected.

If you planned to record a compilation of tracks, be sure to have programmed a selection of tracks on the CD-player or CD-changer from which you are going to record.

Recording

Recording

- 1 To start recording, press Play on the external source from which you want to record. The CD recorder automatically starts recording.
 - If, however, you start the source during a track, recording will start at the beginning of the next track or after 2.7 seconds of silence in analog recordings.
 - Track numbers are automatically incremented. During an analog recording you can insert additional track numbers during recording by simply pressing TRACK INCR. on the remote control.
 - The EASY JOG/ENTER key can be used to adjust the recording level.
 - The recorder stops automatically in case of digital recording from a CD. With AUTO TRACK ON, the recorder pauses and waits for a new track for 1 minute before going to stop. Recordings from DAT, DCC or analog sources will only stop after 20 seconds of silence.
- 2 To stop recording manually, press STOP ■ on the CD recorder.
 - **sync** goes out and the display will show **UPBITE** for several seconds.

Finalizing

If you want to play the recorded CD(RW) on a normal CD player, you must first finalize the disc. Please note that you cannot add anymore tracks on a finalized CDR. See Finalizing CDR and CDRW discs.

Recording a single track



This feature enables you to record a single track from a CD, LP or cassette.

Preparing

- 1 Place an **unfinalized recordable disc**, absolutely free of scratches and dust particles in the CD recorder tray.
- 2 Press SOURCE repeatedly to select the type of connection you made to your source of recording. Examples:
 - CD-player is connected with its digital out connector directly to the digital in connector of your CD-recorder: connection is **DIGITAL I**.
 - CD-player is connected with its analog out connectors directly to analog in connectors of your CD-recorder: connection is **ANALOG**.

• Turntable is connected with its analog out connectors to amplifier/receiver which is connected to the analog in connectors of your CD-recorder: connection is **ANALOG**
→ **DIGITAL I**, **OPTICAL I** or **ANALOG** lights up and **DIGITAL I**, **OPTICAL I** or **ANALOG** will appear on the display.

- 3 With the recorder stopped, press RECORDING TYPE two times to select **REC TRACK** for recording of a single track.
 - **TR** and **sync** start to flash and the display shows the selection.

Recording

- 1 To start recording, press Play on the external source from which you want to record. The CD recorder automatically starts recording.
 - If, however, you start the source during a track, recording will start at the beginning of the next track or after 2.7 seconds of silence in analog recordings.
 - The EASY JOG/ENTER key can be used to adjust the recording level.
 - The recorder stops automatically in case of digital recording from a CD. Recordings from DAT, DCC or analog sources will only stop after 20 seconds of silence.
- 2 To stop recording manually, press STOP ■ on the CD recorder.
 - **sync** goes out and the display will show **UPBITE** for several seconds.

Finalizing

If you want to play the recorded CDR(W) on a normal CD player, you must first finalize the disc. Please note that you cannot add anymore tracks on a finalized CDR. See Finalizing CDR and CDRW discs.

Manual recording

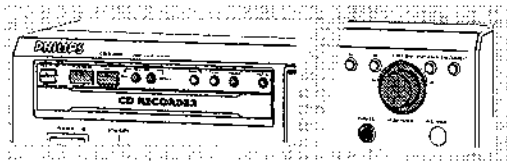

This feature enables you to manually start and stop a recording record from any source. You can use manual recording for recording live music, or for particular music like classic which cannot be recorded with synchronised recording.

Important: For recording from CD-changers, use the RECORD DISC, RECORD TRACK or MAKE CD mode. Do not use REC MANUAL.

Track increments

- During digital recordings, track numbers can be copied automatically from the original.
- For analog recordings, the set can detect silences (longer than 2.7 seconds) in the source material and start a new track. Auto Track is however dependent on the quality of the analog source material and will not always increase the track number like on the original.
- For recordings from noisy external analog sources like LP or cassette tapes we strongly recommend to switch Auto Track to OFF and insert track numbers manually.
- Auto Track is default switched on. If you wish to switch Auto Track off or on:

- 1 Press STORE/MENU.
→ TEXT EDIT will appear on the display.
- 2 Rotate the EASY JOG/ENTER key to select the AUTO TRACK submenu.
→ AUTO TRACK will appear on the display.
- 3 Press EASY JOG/ENTER to confirm.
→ ON or OFF will appear on the display.
- 4 Turn the EASY JOG/ENTER key to select Auto track ON or OFF.
- 5 Press EASY JOG/ENTER to confirm.
→ AUTO TRACK will appear on the display.
- 6 Press STOP ■ to exit.

During analog recording, you can always insert track numbers manually by pressing TRACK INCR. on the remote control. The minimum track length is 4 sec. Track numbers cannot be changed after recording.

Preparing

- 1 Place an unfinalized recordable disc, absolutely free of scratches and dust particles in the CD recorder tray.
 - 2 Press SOURCE repeatedly to select the type of connection you made to your source of recording. Examples:
 - CD-player is connected with its digital out connector directly to the digital in connector of your CD-recorder: connection is DIGITAL I.
 - CD-player is connected with its analog out connectors directly to analog in connectors of your CD-recorder: connection is ANALOG
 - Turntable is connected with its analog out connectors to amplifier/receiver which is connected to the analog in connectors of your CD-recorder: connection is ANALOG
- DIGITAL I, OPTICAL I or ANALOG lights up and DIGITAL I, OPTICAL I or ANALOG will appear on the display.
- 3 With the CD recorder stopped press RECORDING TYPE three times to select REC MANUAL for recording of a single track.
→ ↵ and MANUAL start to flash and the display shows the selection.
- If CHECK INPUT message and the input label DIGITAL I or OPTICAL also flashes, switch on the external source or check the digital connection.
 - You can record a 3-second silence at the start of a track by pressing PLAY/PAUSE ►|| on the CD recorder before starting the recording.

Recording

- 1 To start recording, press RECORD on the CD recorder and immediately start the source.
→ ↵ lights continuously. The track number and recording time will appear on the display.
- To interrupt recording, press PLAY/PAUSE ►|| on the CD recorder.
→ ↵ starts to flash. Resume at step 1.
- 2 To stop recording, press STOP ■ on the CD recorder.
→ UPBRITE lights up and goes out.

After recording the display will show UPBRITE for several seconds.

Note: In case of AUTO TRACK ON, the recorder will stop automatically. Recordings from DAT, DCC or analog recordings will stop after 20 seconds of silence. With AUTO TRACK OFF, the recording will not stop automatically.

Finalizing

If you want to play the recorded CD(RW) on a normal CD player, you must first finalize the disc. Please note that you cannot add anymore tracks on a finalized CDR. See Finalizing CDR and CDRW discs.

Recording

Finalizing CDR & CDRW discs

During finalizing, the table of contents (TOC) is written to the disc.

Finalizing is a simple procedure that is necessary in order to:

- be able to play recordings on a CD PLAYER
- avoid further unwanted recordings on a disc,
- avoid erasure of tracks on a CDRW,
- write CD text on a CDR(W).

Auto finalizing

The CDR(W) is automatically finalized when using the MAKE CD recording function.

Manual finalizing

- 1 Make sure the disc (in the CD recorder) is absolutely free of scratches and dust particles.
- 2 With the recorder stopped, press FINALIZE.
→ The display will show **FINALIZE CD** and **PRESS RECORD**.
- 3 Press RECORD.
→ **### ### FINRL** and the approximate finalization time is shown on the display.
The display counts down through the finalization.
Upon completion, the total number of tracks and the total time recorded will appear on the display.
For CDR(W), **CDR(w)** changes to **CD** on display.

Finalizing will take at least 2- 4 minutes.

Notes:

During finalization, the CD recorder will not accept operating commands.

When a CDR has been finalized, no more recordings can be added.

Unfinalizing CDRW discs

For CDRW discs only

If you want to make more recordings (or erase tracks) on a finalized disc, you must unfinalize it first. The index of the disc content will be removed.

To unfinalize

- 1 With the CD recorder stopped, press RECORDING TYPE or ERASE.
→ **UNFINALIZE** and **PRESS ENTER** will appear on the display.
 - 2 Press JOG (ENTER).
→ The disc will now be unfinalized and can be used again to record.
- If no further recording or erasure is required, press **STOP ■**.

Notes:

*Unfinalizing will take approximately 1.5 minutes.
When unfinalizing a CDRW disc with text available, this text will be transferred to the CD recorder memory. However, if the text memory is full, the message **MEMORY FULL / FINALIZE CD** will be displayed. Text must be erased, stored for other discs, or another disc must be finalized in order to create space in the memory.*

Erasing CDRW discs content

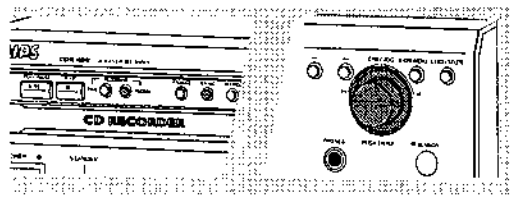

For unfinalized CDRW discs only!

You can erase:

- Tracks can only be erased from the end.
- With the EASY JOG you can select more than one track to be erased simultaneously.

Note: It is not possible to erase tracks within the sequence.

- It is also possible to erase the entire disc at once.

To erase one or more tracks from the end:

- 1 Press ERASE once.
 - The display will show the number of tracks and their total playing time. ERASE TRACK and PRESS RECORD will light up.
- If the disc is finalized, CD will appear on the display after inserting a CDRW in the recorder. The recorder will ask you to confirm unfinalizing first. Confirm by pressing the EASY JOG/ENTER key or ENTER on the remote control.
- 2 Select the track(s) you wish to erase by turning the EASY JOG/ENTER key to the left.
 - The selected track numbers will start blinking on the track bar.
 - The display will show the remaining time after erasing the selected track(s). The track shown will be included in the tracks erased.
- 3 Press RECORD.
 - The display will show the total countdown time and ERASE.
 - After the selected track(s) has/have been erased, the display will show the number of remaining tracks and their total playing time.

To erase the entire disc:

- 1 Press ERASE twice.
 - The display will show the number of tracks and their total playing time. ERASE DISC and PRESS RECORD will light up.
- If the disc is finalized, CD will appear on the display after inserting a CDRW in the recorder. The recorder will ask you to confirm unfinalizing first. Confirm by pressing the EASY JOG/ENTER key or ENTER on the remote control.
- 2 Press RECORD.
 - The display will show the total countdown time and ERASE. The entire disc will be erased.

Erasing an entire disc may take up to 15 seconds.

Playing a CD

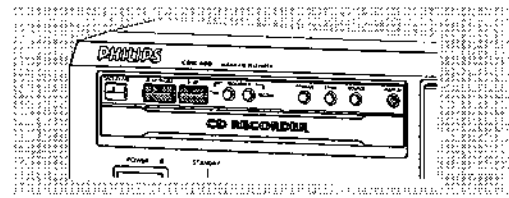

- 1 Press PLAY/PAUSE ►|| to start CD play.
 - ► will light up and the track number and track time of the track in play will appear on the display.
- 2 Press Display once, twice or three times to see:
 - Remaining track time, total remaining time, permanent text information and track time (see Menu mode).
- 3 To interrupt play temporarily, press PLAY/PAUSE ►|| again.
 - || will light on the display.
- 4 To continue play, press PLAY/PAUSE ►|| again.
- 5 To stop play, press STOP ■.
 - The number of tracks and the total playing time will appear on the display.

Selecting a track

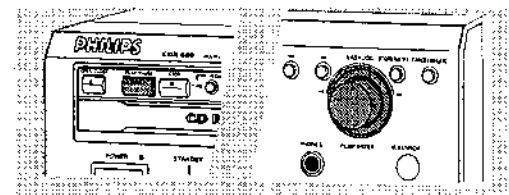

Selecting a track during play

- 1 Turn the EASY JOG/ENTER key until the required track number appears on the display.
 - Play will skip to the beginning of the selected track.

Selecting a track when CD play is stopped

- 1 Turn the EASY JOG/ENTER key until the required track number appears on the display.
- 2 Press EASY JOG/ENTER or ENTER on the remote control to confirm or press PLAY/PAUSE ►|| to start playing.

Note: You can also enter the required track number using the numerical keys on the remote control. For 2 digit numbers, press the keys in rapid succession.

Playing

Search

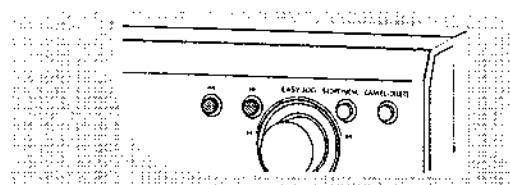

- 1 Hold down ◀ or ▶ (in Play mode).
→ The player first searches backwards or forwards at 10 times normal speed with sound at low volume, then goes to 50 times normal speed with sound muted.
- 2 Release the button at the desired passage.
→ Play will start at the desired passage.

Note: During Shuffle, Repeat Track or Programmed play, search is restricted to within the track being played at the time.

Shuffle (random order) play

- 1 Press SHUFFLE before or during CD play to start shuffle play.
→ The tracks on the CD (or program if set) will play in random order.
- 2 Press SHUFFLE again to return to normal CD play.
→ CD recorder goes to Stop mode.

Note: Shuffle is also cleared when you open the disc tray.

Repeat CD, track or program

- 1 Press repeat one or more times during CD play.
→ When **REPEAT TRACK** lights up, the current track will play repeatedly. When **REPEAT ALL** lights up, the entire disc or program plays repeatedly.
- 2 To return to normal play, press REPEAT one or more times until:
→ The **REPEAT** text disappears from the display.

Note:

You can use shuffle in combination with REPEAT ALL or programmed play.

REPEAT is also cleared when you open the disc tray.

Programming tracks

- You can program up to 99 tracks to play in any desired sequence.
- Tracks can be programmed more than once, but each time counts as a track (**STEP**).

Programming

- 1 In Stop mode press PROGRAM to enter Program mode.
→ **PROG** flashes and **PROGRAM** followed by track information appears on the display.
- 2 Select the desired track numbers by turning the EASY JOG/ENTER key left or right and store by pressing ENTER.

or:

Key in a track number with the number keys and press ENTER to confirm. For 2-digit numbers, press the keys in rapid succession.
→ The track will be stored in the program.
→ The track number, total program time and the number of programmed tracks (**STEPS**) are displayed.

- 3 Repeat step 2 for all tracks to be programmed.
- 4 Press STOP ■ or PROGRAM to end programming.
→ **PROG** lights continuously.
- 5 Press PLAY/PAUSE ▶|| to start programmed play.

Note:

To review the program, press PROGRAM, followed by ◀ or ▶ with the CD recorder in Stop mode.

To add more tracks to the program, repeat steps 1 to 5.

If you try to store more than 99 tracks,

PROG FULL will appear on the display.

Clearing a program

- 1 Press STOP ■ if necessary to stop programmed play.
 - 2 Press STOP ■ again to clear the program.
→ **PROG** will disappear from the display.
- The program is also cleared when you open the disc tray.

Erasing a track from a program

- 1 In Stop mode press PROGRAM to enter Program mode.
- 2 Use ◀ or ▶ to select the track from to be deleted.
→ The track number and program step will be shown on the display.
- 3 Press CANCEL/DELETE to erase the track from the program.
→ The remaining program steps and the remaining playing time on the program will be displayed.

Menu mode

Remarks about Menu mode

- In Menu mode you will have access to a number of features which are not available via the regular keys (on the deck's front and the remote control).
- The TEXT submenus (A-B) allow you to give names to discs and tracks. The disc and track names will be displayed during playback.
- In the RECORDING submenus (D-E) you can set Auto Track and Balance.
- All settings (except Balance) made in Menu mode will be stored in the deck's memory and can be called up and changed at any time.

General operation of Menu

Menu active in Recording or Stop mode!

- 1 When using the remote control, select CDR first.
- 2 Press STORE/MENU on the deck or the remote control to enter Menu mode.
→ TEXT EDIT will appear on the display.
- 3 Rotate EASY JOG/ENTER to select the required submenus:
- 4 Press EASY JOG/ENTER to confirm your selection.
- 5 Rotate EASY JOG/ENTER to select options in the submenu.
- 6 Press EASY JOG/ENTER to confirm selections.
- 7 Press STORE/MENU to store settings and return to the submenu.
- 8 Press STOP ■ to store settings and exit Menu mode.

Note: Text can only be edited for unfinalized discs. (Finalized CDRW discs must be unfinalized first.)

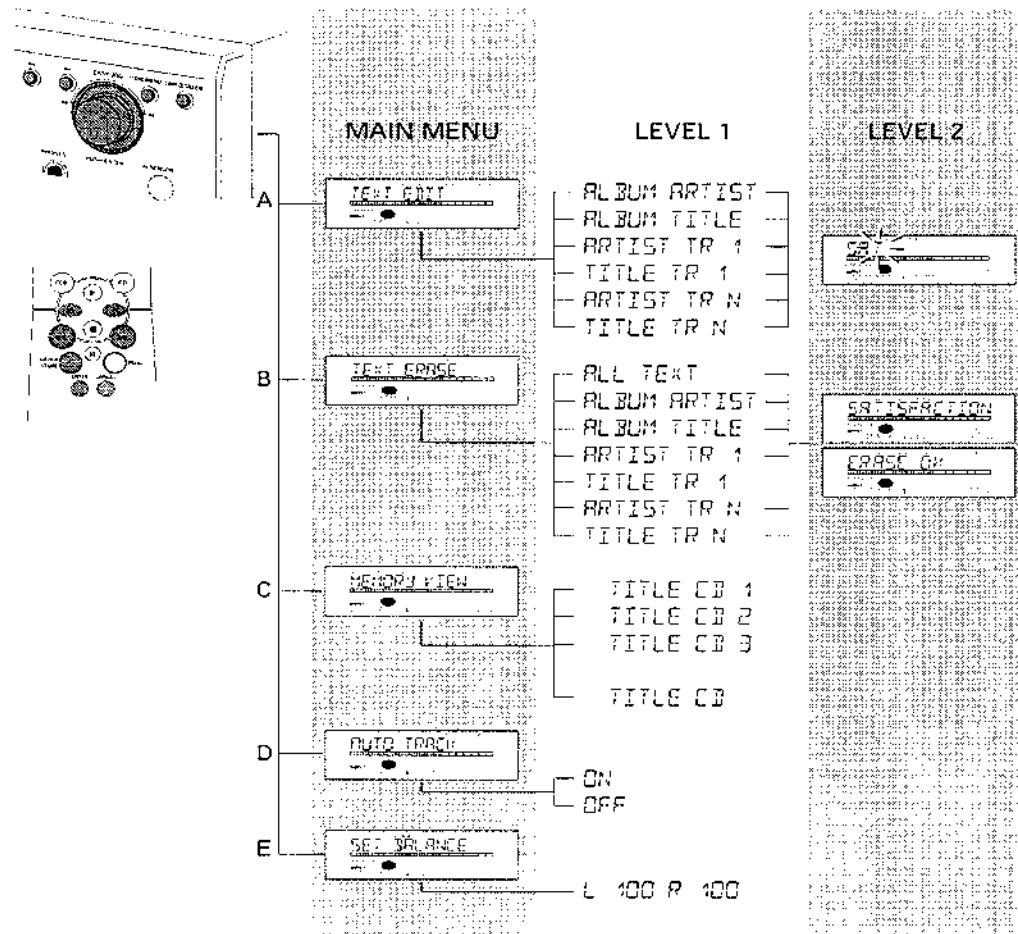

Menu mode

A. Text input

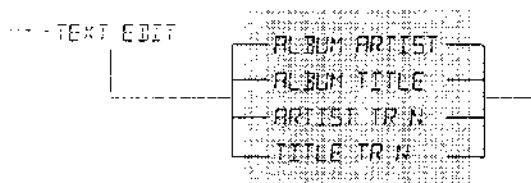

CD text can be added and/or changed to a recording. This can be done in Stop mode or during recording. With this feature you can store the name of artist and album to a CDR as well as a track title and name of artist per title.

Text will be stored in the recorder memory and can be edited until the CDR is finalized. When a CDR(W) is finalized, the CD Text will be written on the disc and removed from the recorder's memory. Text on a (finalized) CDRW can be edited at any time.

- 1 Press STORE/MENU.
→ TEXT EDIT will appear on the display.
- 2 Press EASY JOG/ENTER to confirm.
→ ALBUM ARTIST will appear on the display.
- 3 Rotate EASY JOG/ENTER to select the required option in the submenu: ALBUM ARTIST, ALBUM TITLE, ARTIST TR 1, TITLE TR 1, etc.
- 4 Press EASY JOG/ENTER to confirm.
→ The first character space appears on the display.
- 5 Select the characters by rotating the EASY JOG/ENTER key or by pressing the corresponding numeric/alphabet key on the remote control.
- 6 Press EASY JOG/ENTER to store each character and move to the next cursor position.
- With the ◀◀ and ▶▶ keys you can move to a required cursor position.
- With the CANCEL key you can delete a character.
- 7 Press STORE/MENU to store the name you have entered and return to the submenu, or STOP ■ to exit.

Notes:

A maximum of 60 characters can be stored per item.

By pressing the EASY JOG/ENTER key or ENTER on the remote control without selecting a character first, you can insert a space between characters.

When an artist's name has been stored for a certain track, the name will automatically be copied for the next track. The name can be confirmed by pressing STORE/MENU or a new name can be entered as described above.

B. Erasing text

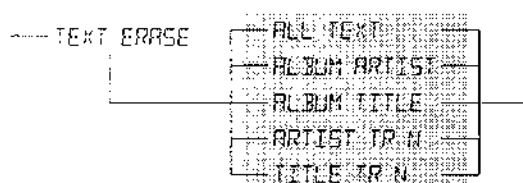

- 1 Press STORE/MENU.
→ TEXT ERASE will appear on the display.
- 2 Rotate the EASY JOG/ENTER key to select the TEXT ERASE submenu.
→ TEXT ERASE will appear on the display.
- 3 Press EASY JOG/ENTER to confirm.
→ ALL TEXT appear on the display.
- 4 Rotate EASY JOG/ENTER to select the required option in the submenu: ALL TEXT, ALBUM ARTIST, ALBUM TITLE, ARTIST TR 1, TITLE TR 1, etc.
- 5 Press EASY JOG/ENTER to confirm.
→ The display will ask you to reconfirm your selection. ERASE OK will appear on the display.
- 6 Press EASY JOG/ENTER to reconfirm.
→ UPDATE will appear on the display.
- 7 Press STORE/MENU to return to the submenu or STOP ■ to exit.

C. Reviewing CD text in memory

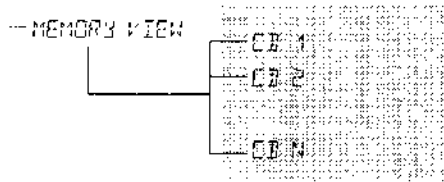

CD text is stored in the recorder's memory. When a CDR(W) is finalized, the CD Text will be written on the disc and removed from the recorder's memory. With the MEMORY VIEW function you can view/delete the CD text in the recorder's memory for each unfinalized disc. The amount of memory used is displayed each time the tray opens with an unfinalized CDR(W) inserted (e.g. MEMORY 50%).

- 1 Press STORE/MENU.
→ TEXT EDIT will appear on the display.
- 2 Rotate the EASY JOG/ENTER key to select the MEMORY VIEW submenu.
→ MEMORY VIEW will appear on the display.
- 3 Press EASY JOG/ENTER to confirm.
→ The first album title in the recorder memory will appear on the display.
- 4 Select the album title you wish to erase.
- 5 Press EASY JOG/ENTER to confirm.
→ ERASE MEMORY will appear on the display.
- 6 Press the EASY JOG/ENTER key to confirm the erasure of the text for that particular disc.
→ UPDATE will appear on the display.
- 7 Press STORE/MENU to return to the submenu or STOP ■ to exit.

Notes:

If there are no discs in the memory, the message MEMORY EMPTY will appear on the display.

When the text memory of your CD recorder is full, the message MEMORY FULL will appear, followed by FINALIZE CD. If you want to add a CD to the list of discs for which text is stored, you will have to erase a disc from this list or finalize another disc for which text is stored.

MEMORY FULL/FINALIZE CD may also appear when unfinalizing a CDRW disc for which text was stored (see 'Unfinalizing CDRW discs'). The same action(s) should be taken in order to obtain memory space.

D. Auto track increment

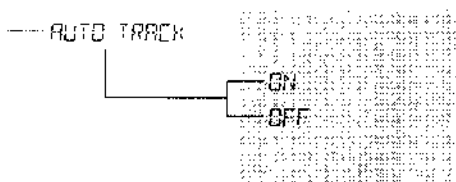

Track increments

During synchronised recordings, track numbers will be copied from the original. This will be done automatically for digital sources. For analog recordings, the set can detect silences (longer than 2.7 seconds) in the source material and start a new track (Auto track increment).

Auto Track is however dependent on the quality of the analog source material and will not always increase the track number like on the original.

Auto Track is default switched on. If you wish to switch Auto Track off or on:

- 1 Press STORE/MENU.
→ TEXT EDIT will appear on the display.
- 2 Rotate the EASY JOG/ENTER key to select the AUTO TRACK submenu.
→ AUTO TRACK will appear on the display.
- 3 Press EASY JOG/ENTER to confirm.
→ ON or OFF will appear on the display.
- 4 Turn the EASY JOG/ENTER key to select Auto track OFF or ON.
- 5 Press EASY JOG/ENTER to confirm.
→ AUTO TRACK will appear on the display.
- 6 Press STOP ■ to exit.

During analog recording, you can always insert track numbers manually by pressing TRACK INCR on the remote control. It is not possible to add track numbers manually during digital recording. The minimum track length is 4 sec. Track numbers cannot be changed after recording.

Note: Auto Track is always active during synchronised recordings.

Menu mode

English

E. Balance

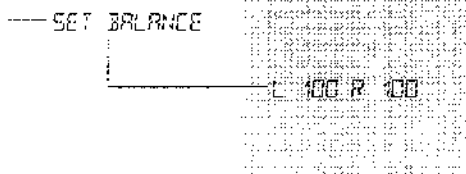

This feature is only active in Record/Standby mode

- 1 Press STORE/MENU.
→ TEST EDIT will appear on the display.
- 2 Rotate the EASY JOG/ENTER key to select the SET BALANCE submenu.
→ SET BALANCE will appear on the display.
- 3 Press EASY JOG/ENTER to confirm.
→ ◀▶ and L 100 R 100 will appear on the display.
- 4 Adjust recording balance by turning the EASY JOG/ENTER key.
 - Turn to the left: the figure on the left (▶) counts down, that on the right counts up.
 - Turn to the right: the figure on the right (◀) counts down, that on the left counts up.
- 5 Press EASY JOG/ENTER to confirm.
- 6 Press STORE/MENU to store settings.

Note: The balance setting will not be stored permanently.

Troubleshooting

WARNING

Under no circumstances should you try to repair the set yourself as this will invalidate the guarantee.

Do not open the set as there is a risk of electric shock.

If a fault occurs, first check the points listed, before taking the set for repair. If you are unable to solve a problem by following these hints, consult your dealer or service centre.

Laser safety

This unit employs a laser. Only a qualified service person should remove the cover or attempt to service this device, due to possible eye injury.

Problem	Solution:
No power	<ul style="list-style-type: none">- ensure that the ON/OFF key is in the on position (red LED on): the CD recorder is in standby mode, press any key to activate it- make sure that the power cable is plugged in correctly- switch the recorder OFF and then immediately back ON
No sound	<ul style="list-style-type: none">- check the audio connections- try using a different source on the amplifier
Amplifier sound is distorted	<ul style="list-style-type: none">- make sure that the CD recorder analog output is not connected to the amplifier Phono input
Play will not start	<ul style="list-style-type: none">- make sure that the label of the CD is facing up- clean the disc- make sure that the disc is not defective by trying another disc
Remote control does not work	<ul style="list-style-type: none">- press CDR on the remote control and try again- point the remote control directly at the CD recorder- check the batteries and replace if necessary- select the right source first
Will not record	<ul style="list-style-type: none">- clean the disc- check if CDR(W) is an unfinalized disc- check that the disc is recordable and replace if necessary- the disc is not an AUDIO disc (WRONG DISC)- wrong input source chosen, Input label flashing (CHECK INPUT)- try using a Philips Audio CDR(W)
Recording is distorted	<ul style="list-style-type: none">- make sure the recording level is correct
20 second pause between recordings	<ul style="list-style-type: none">- see "Autostart recording".
Recorder does not react	<ul style="list-style-type: none">- switch the ON/OFF button on the front of the recorder off and back on
DISC RECOVER on display	<ul style="list-style-type: none">- a power failure has occurred during recording; the CD recorder is attempting to repair the disc
DISC ERROR appears on the display	<ul style="list-style-type: none">- the disc cannot be recorded further, and cannot be finalized.- on a CDRW disc, the track being recorded is lost, but further recording and finalization can still be done
Recorded tracks do not start or stop at the correct time or tracks have been merged together	<ul style="list-style-type: none">- try another auto track setting- check if there are at least 2.7 seconds silence in between the tracks (analog recording only)- insert track increments manually with the remote control
START SOURCE indication	<ul style="list-style-type: none">- start the synchronized external recording by pressing PLAY on the external source you wish to record from.

Alpha MB 2858

8. Faultfinding Guide

8.1 Display Board

8.1.1 Description of display board

General description

The display board has three major parts : the FTD (Fluorescent Tube Display), the display controller TMP87C874F and the keyboard. The display controller is controlled by the DASP master processor on the CDR main board. The communication protocol used is I2C. So all the information between DASP and display controller goes via the SDA or I2C DATA and SCL or I2C CLK lines. Communication is always initiated by the DASP on the CDR main board. Unlike the previous generations of CDR players, the interrupt generated by the display controller at key-press or reception of remote control is not used. Instead, the DASP polls the display controller for these events.

Display controller TMP87C874F

TMP87C874F (IC7104) is a high speed and high performance 8-bit single chip microprocessor, containing 8-bit A/D conversion inputs and a VFT (Vacuum Fluorescent Tube) driver. In this application, its functions are :

- slave microprocessor.
- FTD driver.
- generates the square wave for the filament voltage required for an AC FTD.
- generates the grid and segment scanning for the FTD.
- generates the scanning grid for the key matrix.
- input for remote control.

All the communication runs via the serial bus interface I2C. The display controller uses an 8Mhz resonator as clock driver.

BLOCK DIAGRAM

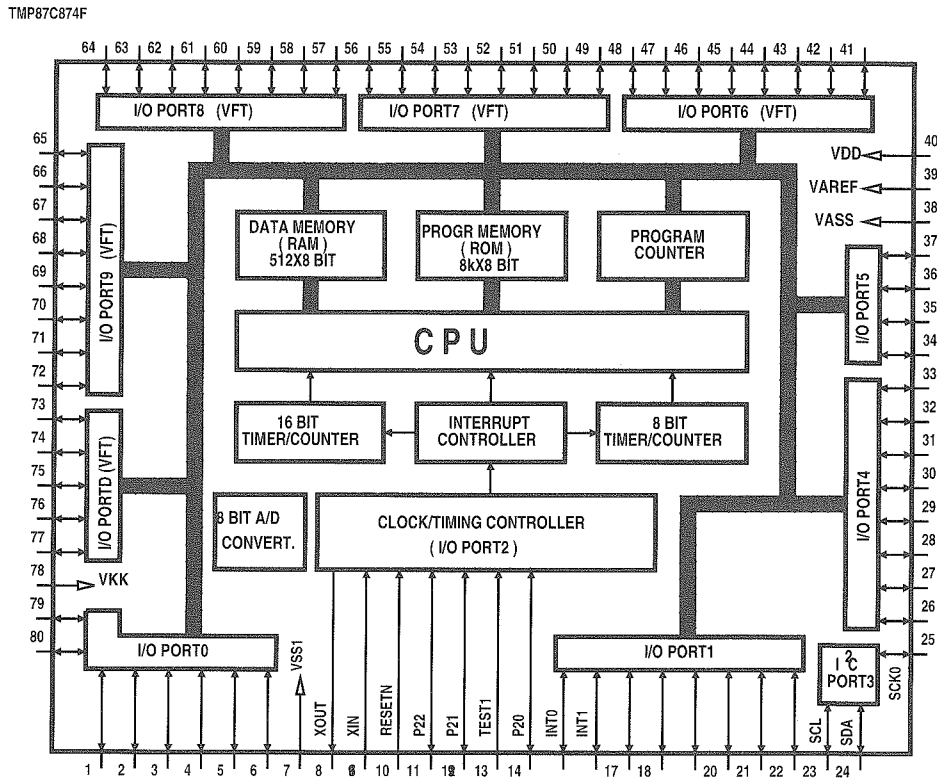

PIN DESCRIPTIONS

INT0	external interrupt input 0
INT1	external interrupt input 1
RESETN	reset signal input, active low
SCL	I2C-bus serial clock input/output
SDA	I2C-bus serial data input/output
TEST	test pin, tied to low
VAREF	analog reference voltage input
VASS	analog reference ground
VDD	+5V
VKK	VFT driver power supply
VSS	ground
XIN, XOUT	resonator connecting pins for high-frequency clock

Figure 8-1

8.1.2 Test instructions

Supply voltages

The display board receives several voltages via connector 1119 (and connector 1121 for CDR570/930).

- VFTD : $-38V \pm 5\%$ measured at pin 2 of conn. 1119.
- VDC1-VDC2 : $3V8 \pm 10\%$ measured between pin 1 and 3 of conn. 1119.
- +5V : $+5V \pm 5\%$ measured at pin 10 of conn. 1119 (pin 4 of conn. 1121 for CDR570/930).

Voltages VFTD, VDC1 and VDC2 are produced in the power supply unit and sent to the display board via the CDR main board. The +5V voltage is produced on the CDR main board as D5V.

Clock signal

As clock driver for the display controller, a resonator of 8 Mhz (1110) is used. The signal can be measured at pins 8 and 9 of the display controller : $8 \text{ Mhz} \pm 5\%$.

Control signals

RESET

The reset signal comes via pin 4 of conn. 1119 from the DASP master processor on the CDR main board (SYS_RESET). The reset is low active. It should be kept low during power up for at least 3 machine cycles with supply voltage in operating range and a stable clock signal (1 machine cycle = $12 \times 1/Fc$ (8 Mhz) sec.). During normal operation, the reset should be high (3V3). The high signal is 3V3 because the DASP operates on 3V3.

I2C DATA/I2C CLK

These lines connect to the DASP master processor via respectively pin 5 and pin 7 of conn. 1119 (pin 5 of conn. 1119 and pin 1 of conn. 1121 for CDR570/930). When there is no communication, they should have the high level (+5V). The oscillogram below gives an indication of how these signals should look like.

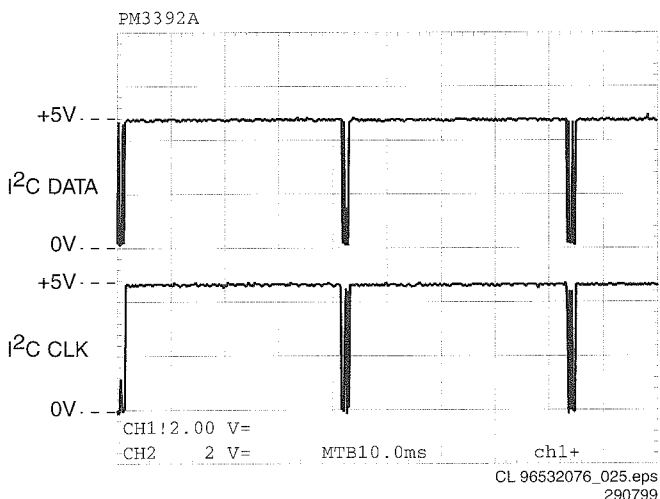

Figure 8-2 'I2C signals'

FTD drive lines

Filament voltage

Should measure $3.8V \pm 10\%$ (=VDC1-VDC2) between pins 1-2-3 and pins 45-46-47 (pins 1-2 and pins 48-49 for CDR570/930) of the FTD (1113).

Grid lines

Level and timing of all grid lines, G1-->G15, can be checked either at the FTD itself or at the display controller. Grid lines G13, G14 and G15 each have an extra current amplifier in line : T7203 for G13, T7204 for G14 and T7100 for G15. A typical grid line signal shows in the oscillogram below.

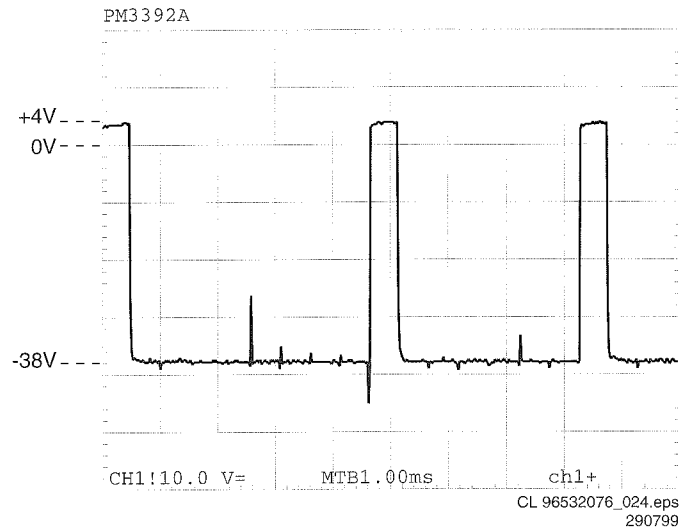

Figure 8-3 'Gridline'

Segment lines

Level and timing of all segment lines, P1-->P21 (P1-->P20 for CDR570/930), can be checked either at the FTD itself or at the display controller. The data on these segment lines however, depends on the characters displayed. The oscillogram below shows a segment line with data. A segment line without data maintains a -38V level.

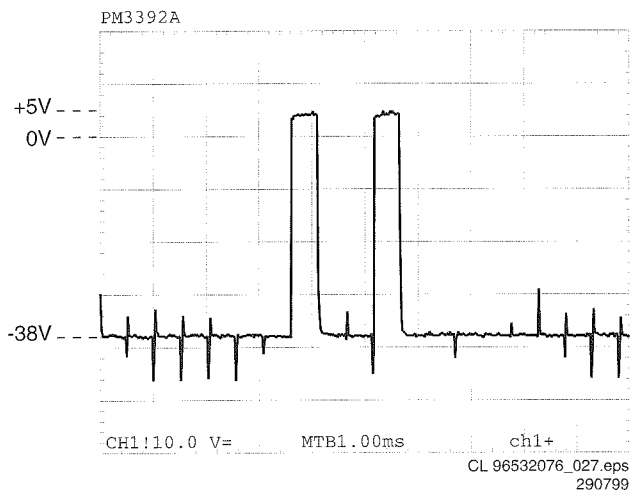

Figure 8-4 'Segment line'

Key matrix lines

The lines connected to pins 34, 35, 36 and 37 of the display controller act as matrix scanners. Without a key pressed, they maintain a low level. As soon as a key is pressed, the scanning line connected to that key puts out a scanning signal, which should look like the oscillogram below. This scanning signal goes via the pressed key to I/O port 4 of the display controller (pins 28 to 33). The display controller can now determine which

key has been pressed. Without a key pressed, pins 28 to 33 of the display controller maintain a high level (+5V).

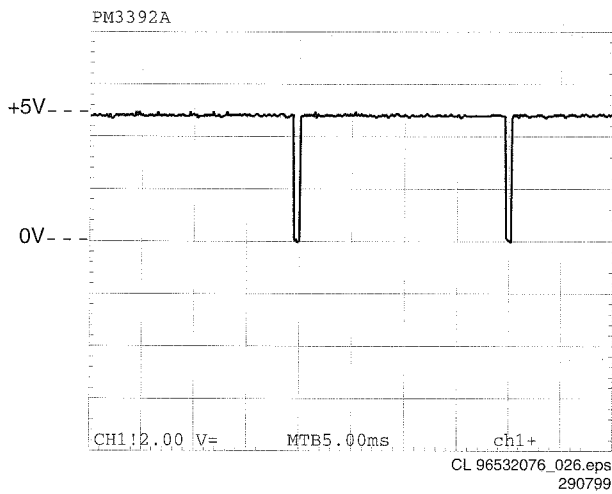

Figure 8-5 'Key matrix scan line'

Easy jog knob

Rotary operation

The easy jog knob (1050) incorporates a whole heap of user control possibilities in just one knob. Without the knob being operated, pin 1 and 3 of the knob (and thus pin 16 and 17 of the display controller), maintain the +5V level. Turning the knob clockwise briefly connects pin 1 to GND followed by pin 3.

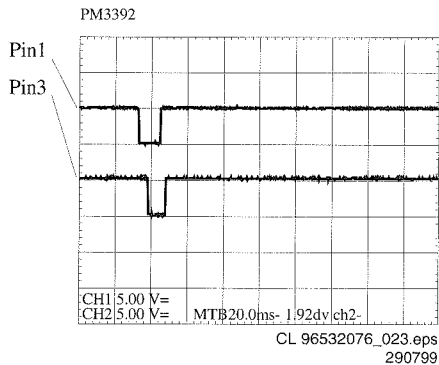

Figure 8-6 'Turn clockwise'

Turning the knob anti-clockwise briefly connects pin 3 to GND followed by pin 1.

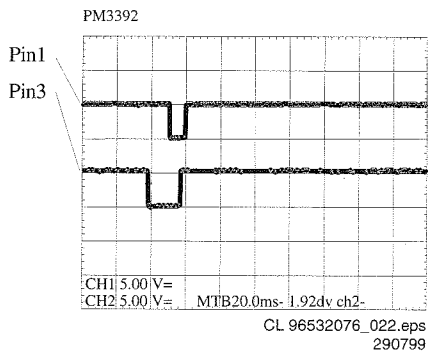

Figure 8-7 'Turn anti-clockwise'

The pulses created this way arrive at pin 16 and 17 of the display controller. The first pulse to arrive tells the controller the direction of the rotation. Counting the pulses reveals the amount of rotation. Combining and decoding this information, the display controller will execute the appropriate task.

Push button operation

This button connects to the key matrix lines and thus the operation is identical to the ordinary keys. Without being pressed, pin 4 of the easy jog maintains the low level, pin 5 the high level. When pressed the scanning signal goes through the closed contact of pins 4 and 5, and can be checked at both pins.

IR receiver - remote control

In the CDR570/930 the IR receiver TSOP1736 (6101) is mounted on the display board. In the CDR770 that same IR receiver (6200) is mounted on a small board together with the headphone socket. In the CDR775 the IR receiver (6200) is mounted on its own small board. In all versions the IR receiver connects to the display controller. The signal coming from the receiver can be checked at pin 22 of the display controller. This signal is normally high (+5V). When the remote control is being operated, pulses mixed in with the +5V can be measured. The oscillogram gives an indication of how the signal looks like with the RC being operated.

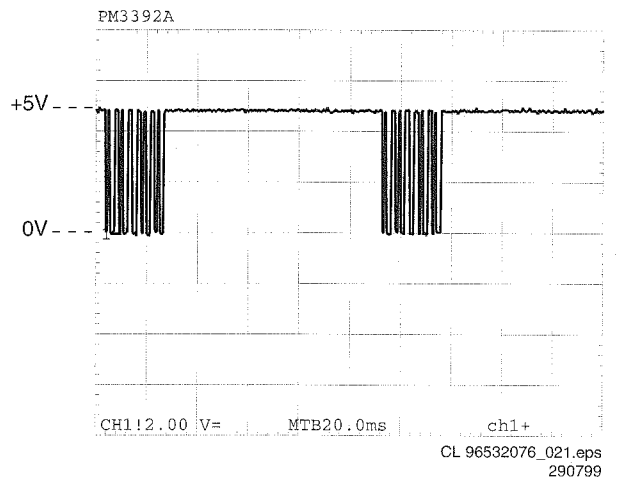

Figure 8-8 'IR receiver signal'

8.1.3 Display board troubleshooting guide

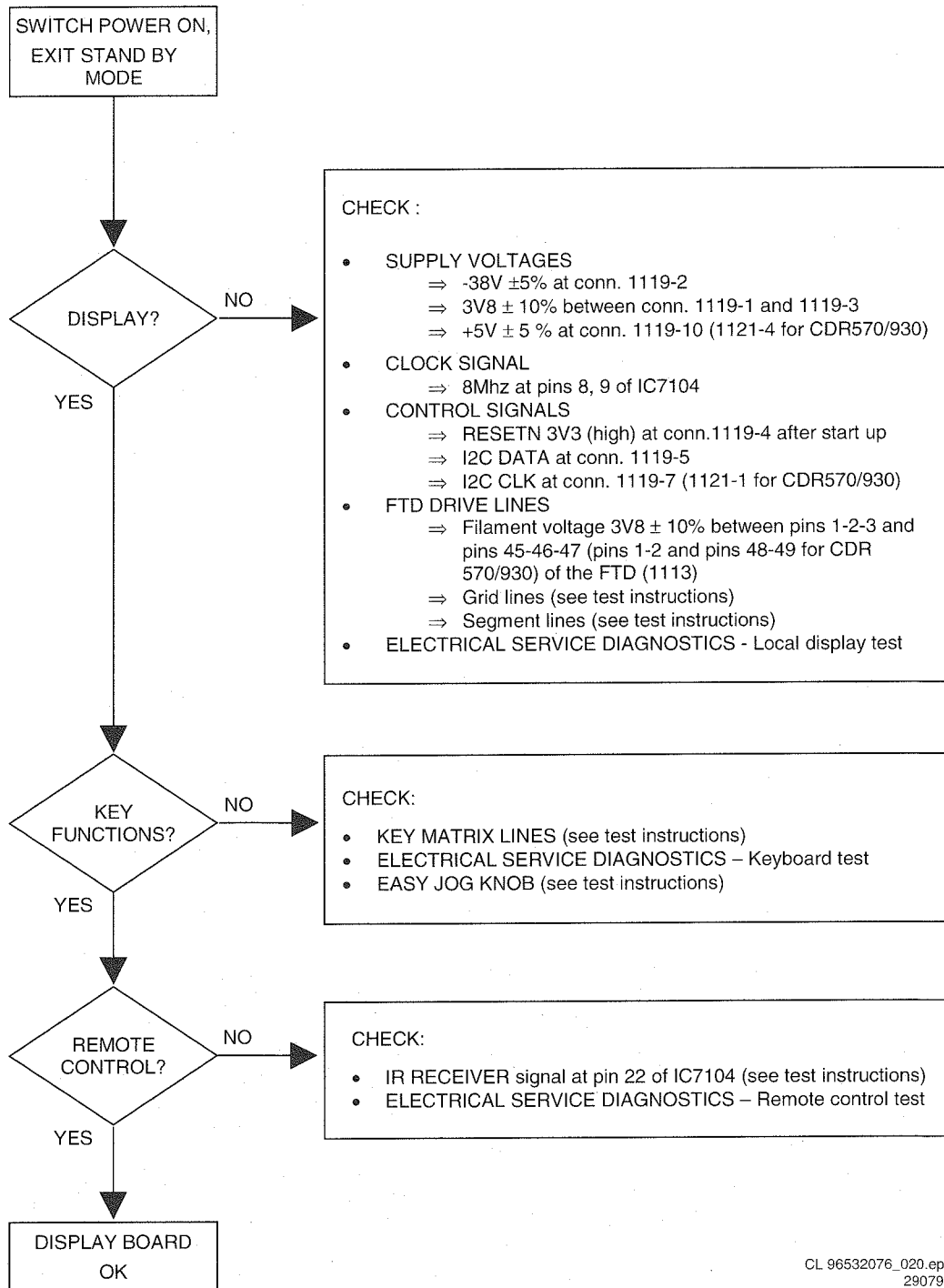

Figure 8-9 'Display board troubleshooting'

Circuit description of the current mode power supply

Blockdiagram

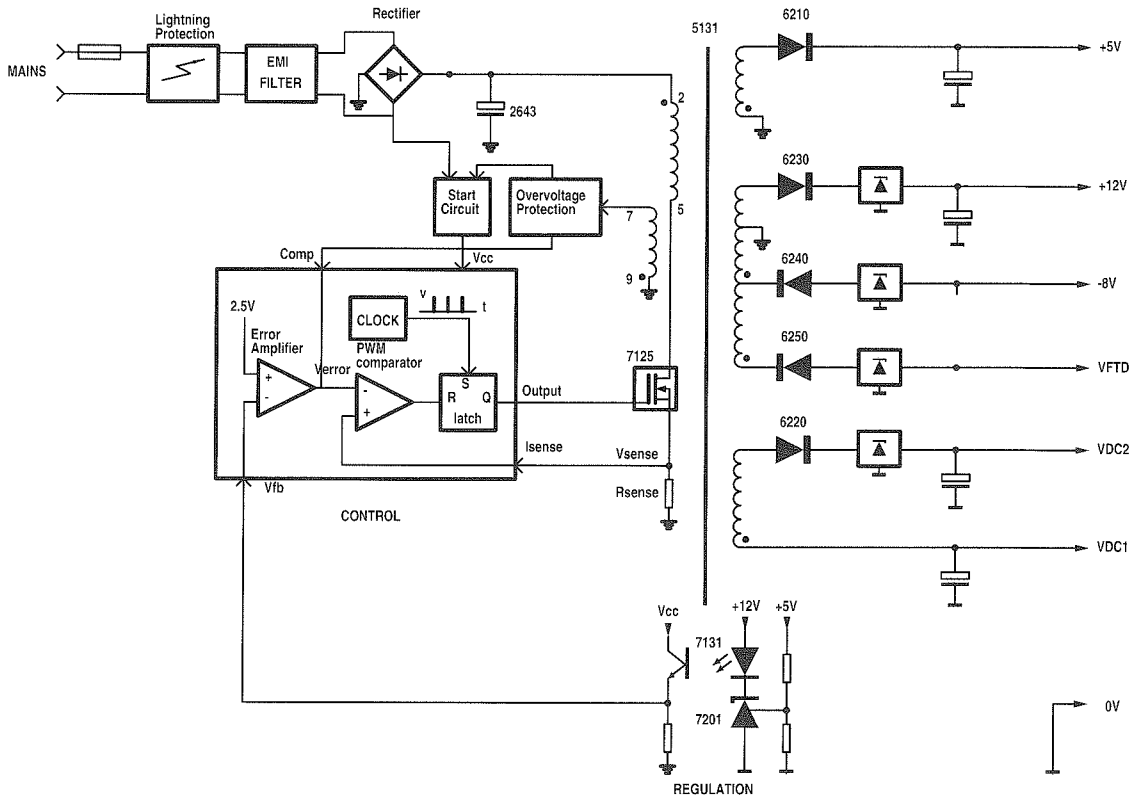

Figure A: Blockdiagram power supply

Function description

MOSFET 7125 is used as a power switch controlled by the controller IC 7110. When the switch is closed, energy is transferred from mains to the transformer. This energy is supplied to the load when the switch is opened. Through control of the switched-on time, the energy transferred in each cycle is regulated so that the output voltages are independent of load or input voltage variations. The controlling device UC3842 is an integrated pulse width modulator. A clock signal initiates power pulses at a fixed frequency. The termination of each output pulse occurs when a feedback signal of the inductor current reaches a threshold set by the error signal. In this way the error signal actually controls the peak inductor current on cycle-by cycle basis.

Description of UC3842

The input voltage V_{cc} (pin 7) is monitored by a comparator with hysteresis, enabling the circuit at 16V and disabling the circuit below 10V. The error amplifier compares a voltage V_{fb} (pin 2) related to the output voltage of the power supply, with an internal 2.5V reference. The current sense comparator compares the output of the error amplifier with the switch current I_{sense} (pin 3) of the power supply. The output of the current sense comparator resets a latch, which is set every cycle by the oscillator. The output stage is a totem pole, capable of driving a MOSFET directly

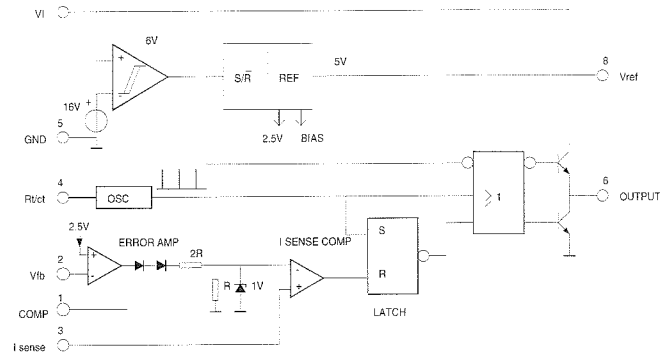

Figure B : Blockdiagram UC3842

Start up sequence

t1: Charging the capacitor at V_{cc}

C_{2129} will be charged via R_{3123} and R_{3134} , C_{2133} and C_{2111} via R_{3129} . The output is switched off during t_1 .

t2: Charging of output capacitors

When the input voltage of the IC exceeds 14,5V, the circuit is enabled and starts to produce output pulses. The current consumption of the circuit increases to about 17mA, depending on the external loads of the IC. At first, the capacitor at the V_{cc} pin will discharge because the primary auxiliary voltage, coming from winding 7-9 is below the V_{cc} voltage. At some moment during t_2 , the primary auxiliary voltages reaches the same level as V_{cc} . This primary auxiliary voltage now determines the V_{cc} voltage

t3: regulation

The output voltage of the power supply is in regulation

t4: overload

When the output is shortened, the supply voltage of the circuit will decrease and after some time drop below the lower threshold voltage. At that moment, the output will be disabled and the process of charging the V_{cc} capacitor starts again. If the output is still shorted at the next t_2 phase, the complete start-and stop sequence will repeat.

The power supply comes in a hiccup mode

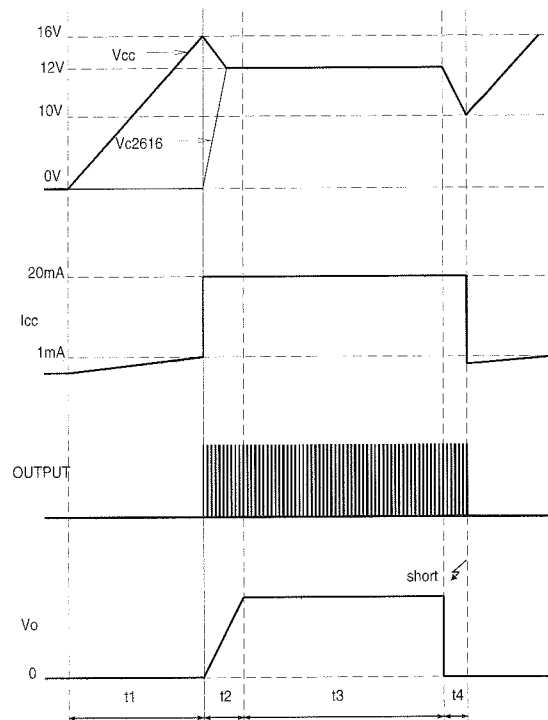

Figure C: Start-up sequence

Regulation

Figure 4 shows the most relevant signals during the regulation phase of the power supply.

The oscillator voltage ramps up and down between V_1 and V_2 . The voltage at the current sense terminal is compared every cycle with the output of the error amplifier V_{comp} . The output is switched off when the current sense level exceeds the level at the output of the error amplifier.

1. **Time_{ON} phase** : A drain current will flow from the positive supply at pin 1 through the transformer's primary winding, the MOSFET and R_{sense} to ground. As the positive voltage at pin 1 of the transformer is constant, the current will increase linearly and create a ramp dependent on the mains voltage and the inductance of the primary winding. A certain amount of energy is stored in the transformer in the form of a magnetic field. The polarity of the voltages at the secondary windings is such that the diodes are non-conducting.
2. **Time_{DIODE} phase** : When the MOSFET is switched off, energy is no longer supplied to the transformer. The inductance of the transformer now tries to maintain the current which has been flowing through it at a constant level. The polarity of the voltage from the transformer therefore becomes reversed. This results in a current flow through the transformer's secondary winding via the diodes, electrolytic capacitors and the load. This current is also ramp shaped but decreasing.
3. **Time_{DEAD} phase** : when the stored energy has been supplied to the load, the voltage from the secondary windings falls below the output voltage (held constant by the electrolytic capacitors) plus the threshold voltage of the diodes. The current in the secondary winding stops flowing. At this point, the drain voltage of the MOSFET is not yet zero because C_{2609} between drain and source contains a certain charge. This charge will start a sine-shaped ringing together with the transformer's self-induction.

The oscillator will start a next cyclus which consists of the described three phases.

The time of the different phases depends on the mains voltage and the load.

$Time_{DEAD}$ is maximum at an input of $400V_{DC}$ and minimum load, it will be zero at an input of $100V_{DC}$ and overload.

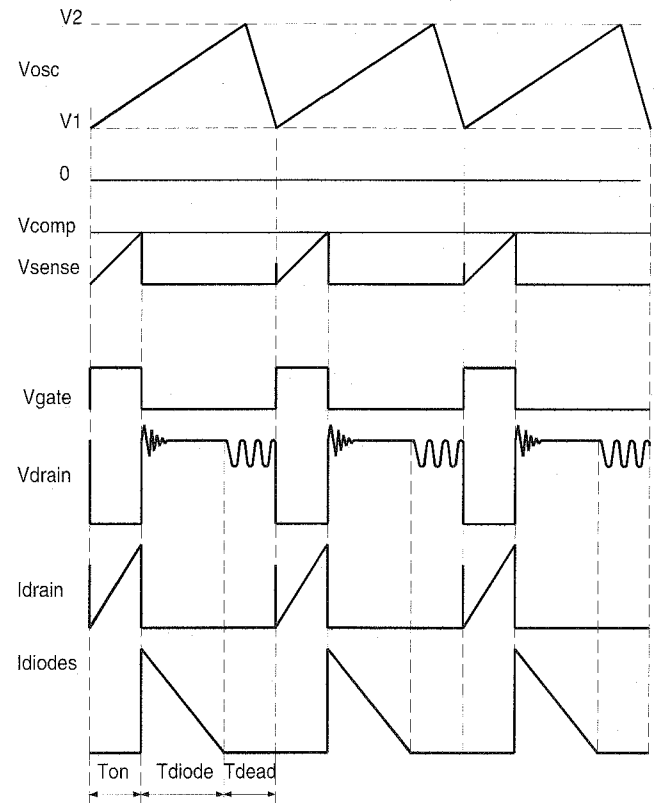
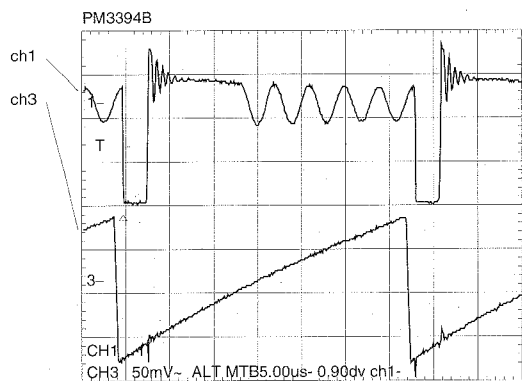

Figure D

Oscillograms



ch1 : Drain voltage at testpoint T632
 ch2 : Drain current
 ch3 : Gate voltage at testpoint T669



ch1 : Drain voltage(T632)
 ch2 : Oscillator voltage at pin 4 of IC7612

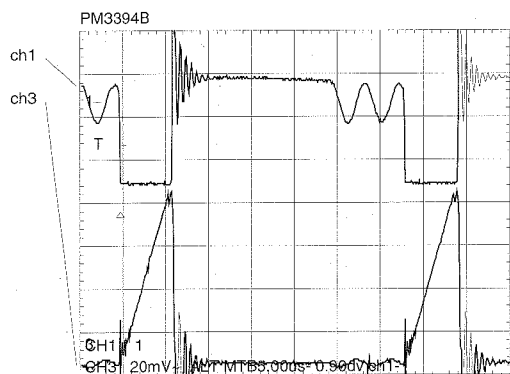

ch1 : Drain voltage(T632)
 ch3 : Sense voltage(T612)

Circuit description

Input circuit

The input circuit consists of a lightning protection circuit and an EMI filter.

The lightning protection comprises R3120, gasarrestor 1125 and R3124.

The EMI filter is formed by C2120, L5120, C2125 and R3124. It prevents inflow of noise into/from the mains.

Primary rectifier/smoothing circuit

The AC input is rectified by rectifier bridge 6102 and smoothed into C2121. The voltage over C2121 is approximately 300V. It can vary from 100V to 390V.

Start circuit and Vcc supply

This circuit is formed by R3123, R3134, C2129, D6129, R3129, R3111, C2133 and C2111.

When the power plug is connected to the mains voltage, the stabilised voltage over D6129(24V) will charge C2133 via R3129. When the voltage reaches 14,5V across C2111, the control circuit of IC7110 is turned on and the regulation starts. During regulation, Vcc of IC7110 will be supplied by the rectified voltage from winding 7-9 via L5132, D6132 and C2133.

Control circuit

The control circuit exists of IC7110, C2102, C2104, C2107, C2109, C2110, R3102, R3103, R3104, R3107, R3108, R3109 and R3110. C2102 and R3110 define the frequency of the oscillator.

Power switch circuit

This circuit comprises MOSFET 7125, Rsense 3126, 3127 and 3128, R3125, C2127, L5125, R3112 and R3113. R3125 is a pull-down resistor to remove static charges from the gate of the MOSFET.

Regulation circuit

The regulation circuit comprises opto-coupler 7200 which isolates the error signal from the control IC on the primary side and a reference component 7201.

The TL431(7201) can be represented by two components:

- a very stable and accurate reference diode
- a high gain amplifier

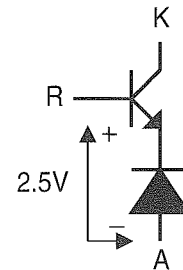

TL431 will conduct from cathode to anode when the reference is higher than the internal reference voltage of about 2.5V. If the reference voltage is lower, the cathode current is almost zero.

The cathode current flows through the LED of the opto-coupler. The collector current of the opto-coupler flows through R3106, producing an error voltage, connected to voltage feedback pin 14 of IC7110.

Overvoltage protection circuit

This circuit consist of D6114, C2114, R3115and R3116. When the regulation circuit is interrupted due to an error in the control loop, the regulated output voltage will increase (overvoltage). This overvoltage is sensed on the primary winding 7-9. When an overvoltage longer than 2.0µs is detected, the output is disabled until Vcc is removed and then re-applied. The power supply will come in a hiccup mode as long as the error in the control loop is present.

Secondary rectifier/smoothing circuit

There are 5 rectifier/smoothing circuits on the secondary side. Each voltage depends on the number of windings of the transformer.

The -8V supply is regulated by voltage regulator 7249.

On/off circuit

In off mode pin 1 and pin 2 of connector 0206 are connected. The high voltage (-8V, +12V) over opto coupler 7200 forces this one to conduct . IC 7110 is switched off

TROUBLE SHOOTING POWER SUPPLY

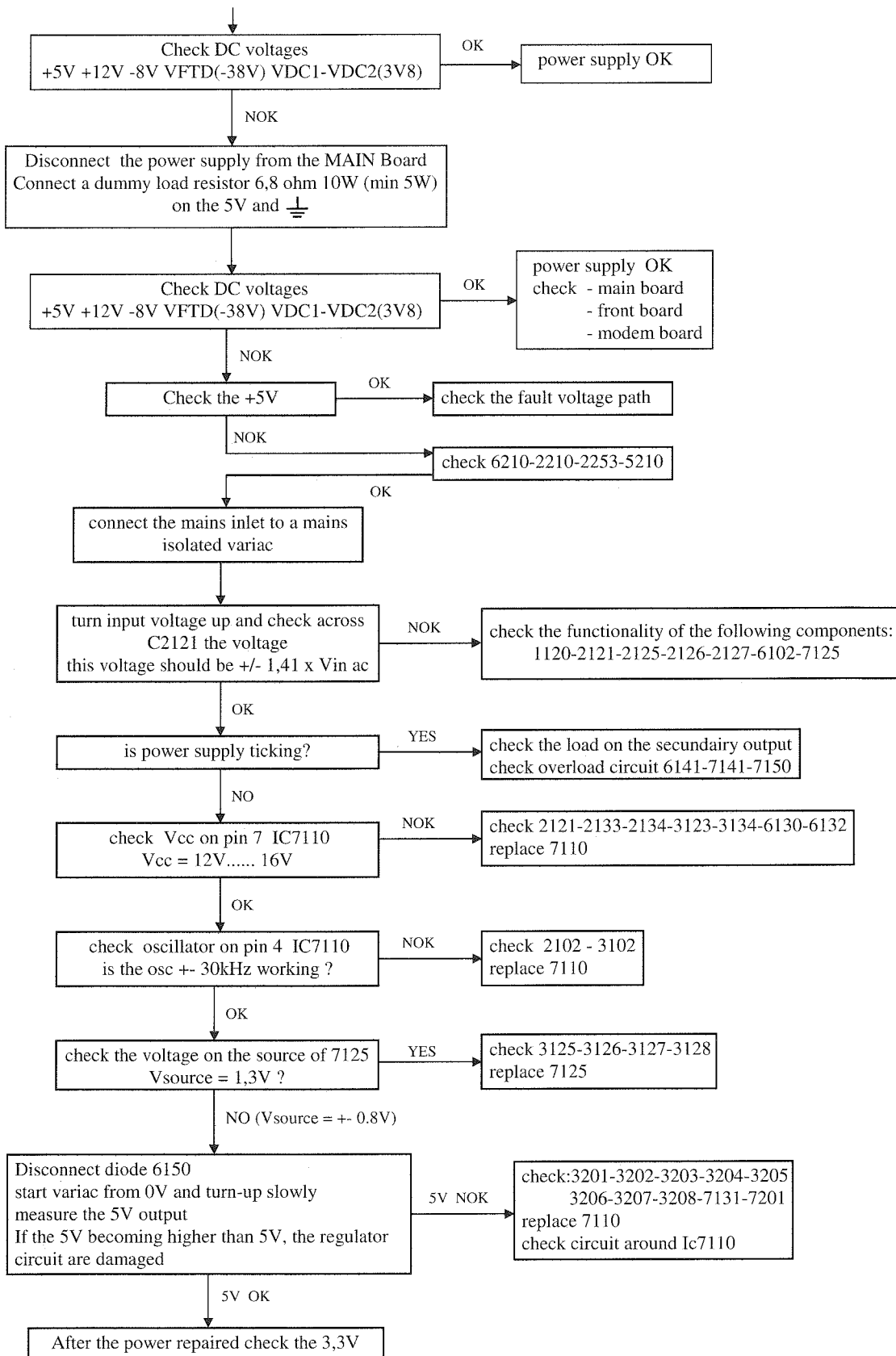

9. List of Abbreviations

SIGNAL NAME	SIGNAL FLOW	FUNCTION AND DESCRIPTION
+12V	main supply voltage from PSU	+12V supply voltage from PSU
+12VA	supply voltage	+12V supply voltage for Audio part
+5V	main supply voltage from PSU	+5V supply voltage from PSU
+5VA	supply voltage	+5V supply voltage for Audio part
+9SRVPWR	IC7558 -> IC7240	PoWeR supply for SeRVo driver IC
12VPWR	supply voltage	+12V supply voltage for servo part
-8V	main supply voltage from PSU	-8V supply voltage from PSU
-8VA	supply voltage	-8V supply voltage for Audio part
A(1:20)	IC7701 -> R3818,R3819, R3820, R3821, R3897 -> IC7703	Address lines 1 to 20 between DASP and flash ROM
A(10:20)	IC7701 -> R3819, R3820, R3821 -> IC7702	Address lines 10 to 20 between DASP and DRAM
A1	IC7010 -> IC7270	amplitude of the "land" reflection relative to the average EFM, voltage output, OPC input
A1LF, A2LF	CONN1000 -> IC7010	satellite photo diodes A1, A2 current output
A2	IC7010 -> IC7270	amplitude of the "pit" reflection relative to the average EFM, voltage output, OPC input
A-8V	supply voltage	-8V supply voltage for servo part
AEGER		Analog Error signal GEnerator for Recordable
AINTON	IC7008 -> IC7010	Alpha INTegrator ON (to AEGER)
ALE	IC7270 -> R3213 -> IC7209, IC7300IC7270 -> R3230	Address Latch Enable; external address latch strobe line, freeze address when low
ALPHA0	IC7270 -> IC7010	analog voltage mode output from OPC D/A converter
ALS	IC7008 -> IC7010	Alpha Loop Switch (to AEGER)
ASTROBE	IC7008 -> IC7010	Alpha STROBE (to AEGER)
ATIP		Absolute Time In Pre-groove (sync signal)
ATIPSYNC	IC7300 -> IC7270	ATIP SYNC signal
ATT	IC7270 -> R3717, R3722IC7270 -> IC7701	ATTenuation request from MACE2 to audio DAC, active low; means that the output can be attenuated in case of search activities
B1LF, B2LF	CONN1000 -> IC7010	satellite photo diodes B1, B2 current output
BCLK	IC7701 -> R3898A -> IC7300	I2S1 BitCLock from DASP to CDR60 (playback and record)
BE_RESET	IC7701 -> R3261 -> IC7270IC7701 -> R3716	Basic Engine RESET, active high
BIASC	IC7008 -> R3056	BIAS Current switch CDRW output
BKPT	CONN1819, R3907 -> IC7701	JTAG mode select / debug mode BreakPoinT
C1LF, .. , C4LF	CONN1000 -> IC7010	Central photo diodes C1, C2, C3, C4 current output
CAGAIN	R3016,R3115 -> IC7010	set-point laser power on disc, current input
CAHF	CONN1000 -> C2374	Central Aperture (central photo diodes) High Frequency current output (C1+C2+C3+C4)
CALF	IC7010 -> IC7270	Central Aperture (central photo diodes) Low-pass Filtered signal (DC coupled EFM signal), voltage output, OPC input
CAS0	IC7701 -> IC7702	Column Address Strobe DRAM for upper byte
CAS1	IC7701 -> IC7702	Column Address Strobe DRAM for lower byte
CDR	IC7008 -> IC7355	CDR strategy detected output (active high)
CDR60CFLG	IC7300 -> R3382B -> CONN1812	serial output of error corrector status information of the CDR60-decoder, to be measured at test connector
CDR60CL1	IC7300 -> R3382C -> CONN1812	output of CLock signal for testing system clock of IC CDR60 at test connector
CDR60CS	IC7270 -> R3235B -> R3702, IC7300	CDR60 Chip Select, active high
CDR60INT	IC7300 -> IC7270	CDR60 INTerrupt line, active low
CDR60LWRT	IC7300 -> R3048	CDR60 Laser WRiTe control output
CDR60MEAS1	IC7300 -> R3382A -> CONN1812	serial output of information about jitter, PLL frequency and asymmetry of bit recovery block in CDR60, to be measured at test connector
CDR60PLL	IC7270 -> R3305 -> IC7300	CDR60 clock multiplier enable, active high
CDRW	IC7355D -> IC7355CIC7355D -> CONN1000	inverted CDR-strategy-detected signal
CLK_OUT	IC7701 -> R3771 -> CONN1819	system CLock OUT
CLK_SYS	IC7701 -> R3727, R3731	oscillator output
COS-	CONN1220 -> IC7225B	Hall feedback signal from sledge motor

COS+	CONN1220 -> IC7225B	Hall feedback signal from sledge motor
CSFLASH	IC7701 -> IC7703	Chip Select for FLASH or boot device
CSRAM	IC7270 -> R3235A -> R3703, IC7802	Chip Select SRAM, active low
D(16:31)	IC7701 <-> R3822, R3823, R3824, R3825 <-> IC7703, IC7702	Databus bit 16 to 31 between DASP, flash ROM and DRAM
D3V3	supply voltage	+3,3V supply voltage for Digital part
D5V	supply voltage	+5V supply voltage for Digital part
D5VS	supply voltage	+5V supply voltage for Servo part
DALPHA	IC7010 -> R3037	ALPHA error signal for laser power control
DASP		Digital Audio Signal Processor
DATAI	IC7701 -> R3898C -> IC7300	I2S1 DATA In from DASP to CDR60 (recording)
DATAO	IC7300 -> R3314 -> IC7701	I2S1 DATA Out from CDR60 to DASP (playback)
DEEMP	IC7270 -> R3719, R3724IC7270 -> IC7701	DE-EMphasis control for audio DAC from MACE2, active high; means that de-emphasis is needed in digital filter
DELTAP	IC7016 -> R3126	DELTA Power current source drive signal from XDAC
DIG_OUT_C	IC7701 -> R3706 -> C2707, CONN1400	Common DIGital OUTput (consumer)
DISPLAY_INT	F934 -> R3812, IC7701	DISPLAY INTerrupt
DMON	IC7270 -> R3324	power save at stop, active low
DOBM_CD	CONN1708, C2731 -> R3757 -> R3903 -> IC7701	Digital Output (EBU output) from CD player in CDR775 to DASP
DOBM_CDR	IC7300 -> R3382D -> C2379, IC7701	Digital Output (EBU output) from CDR60 to DASP
DRAM_RW	IC7701 -> IC7702	Read/Write strobe for DRAM
DSA_ACK_CD	IC7701 <-> R3830 <-> R3831 <-> CONN1708IC7701 <-> R3830 <-> C2735	Data/Strobe/Acknowledge serial communication between DASP and CD-player in CDR775
DSA_ACK_CDR	IC7701 -> R3729 -> IC7270, CONN1830IC7701 -> R3729 -> R3769	Data/Strobe/Acknowledge serial communication between MACE2 and DASP for CDR; acknowledge input for MACE2 is strobe output for DASP
DSA_DATA_CD	IC7701 <-> R3828 <-> R3829 <-> CONN1708IC7701 <-> R3828 <-> C2733	Data/Strobe/Acknowledge serial communication between DASP and CD-player in CDR775
DSA_DATA_CDR	IC7270<->R3246 <-> R3813 <-> IC7701, CONN1830IC7270<->R3246 <-> R3767	Data/Strobe/Acknowledge serial communication between MACE2 and DASP for CDR
DSA_STR_CD	IC7701 <-> R3835 <-> R3832 <-> CONN1708IC7701 <-> R3835 <->C2734	Data/Strobe/Acknowledge serial communication between DASP and CD-player in CDR775
DSA_STR_CDR	IC7270 -> R3245 -> IC7701, CONN1830IC7270 -> R3245 -> R3768	Data/Strobe/Acknowledge serial communication between MACE2 and DASP for CDR (strobe output for MACE2 is acknowledge input for DASP)
DSCLK	CONN1819, R3908 -> IC7701	reset in / Debug Serial CLock in
DSI	CONN1819, R3909 -> IC7701	JTAG reset in / Debug Serial clock In
EFM		Eight to Fourteen Modulation = modulation method used for CD storage, also the actual raw CD signal as written or read on or from the CD disc
EFMCLK	IC7300 -> IC7008	EFM CLock output
EFMDATA	IC7300 -> IC7008	EFM DATA output
EFMTIM3		EFM TIMing generator
EPON	IC7008 -> R3010IC7008 -> C2010	Erase Power ON
EPONO	IC7008 -> R3107	Erase Power ON Open drain output
EPONRC	R3004 -> CONN1000	Erase Power ON (after RC circuit)
ERASEC	IC7008 -> R3087	ERASE Current switch CDRW output
ERON	IC7008 -> IC 7010	ERror ON (to AEGER)
EXT_DIG_IN1	CONN1400 -> IC7701	EXTernal DIGital INput 1
EXT_DIG_IN2	CONN1702, C2767, C2721 -> R3701 - >IC7701	EXTernal DIGital INput 2 (CDR950 only)
EXT_OPT_IN	CONN1400, C2722 -> R3708 -> IC7701	EXTernal OPTical INput
F_READY	IC7703 -> R3817 -> IC7701CONN1701 -> IC7701	Flash READY detection, this line is forced low as long as the flash is busy with erase or program algorithm
F_RW	IC7701 -> IC7708B	Read/Write strobe for Flash ROM
FEN	IC7010 -> IC7270	Focus Error Normalized current output
FOC-	IC7240 -> CONN1000	FOCus actuator drive signal negative connection
FOC+	IC7240 -> CONN1000	FOCus actuator drive signal positive connection
FS30V	D6500 -> CONN1000	Forward Sense diode 30V power supply
FSA	CONN1000 -> T7119, T7120	Forward Sense photo diode current output
FSCLR	IC7008 -> IC7126	Forward Sense signals CLear switch
FSOF	IC7008 -> R3052	Forward Sense photo diode sampling Off

FSON	IC7008 -> R3051	Forward Sense photo diode sampling ON
FSR	R3040 -> IC7270	Forward Sense signal while Reading for read control loop
FSRS	IC7008 -> IC7126D	Forward Sense photo diode Read Sampling
FSW	R3050 -> IC7270	Forward Sense signal while Writing for write control loop
FSWS	IC7008 -> IC7126C	Forward Sense photo diode Write Sampling
FWEN	IC7270 -> IC7208, R3806	Flash EPROM Write ENable
HALL_U, HALL_V, HALL_W	IC7330 -> IC7300, CONN1812	HALL feedback signals from turn table motor via hall motor driver
HFS0	IC7270 -> R3249 -> IC7360	select HF circuit
I2C		Inter IC
I2C_CLK	IC7701, R3711 -> R3715 -> C2709 -> F934IC7701, R3711 -> IC7801	I2C CLock line used for display slave processor and digital potmeter
I2C_DATA	IC7701, R3712 <-> R3713 <-> C2708, R3714 <-> F934IC7701, R3712 <-> IC7801	I2C DATA line used for display slave processor and digital potmeter
I2CL	R3248B -> IC7207, R3247C	I2C CLock line
I2CSCL	IC7207 -> IC7008IC7207 -> IC7010IC7207 -> R3248B	I2C Serial CLock line
I2CSDA	IC7207 <-> IC7008IC7207 <-> IC7010IC7207 <-> R3248A	I2C Serial DAta line
I2DA	R3248A <-> IC7270, R3247D	I2C DAta line
I2S_BCLK_AI	IC7701 -> R3814 -> IC7406	I2S4 Bit CLock for CODEC (ADC for CDR950) Analog Input (record from analog source)
I2S_BCLK_AO	IC7701 -> R3894A -> IC7406	I2S2 Bit CLock for CODEC (DAC for CDR950) Analog Output
I2S_BCLK_CD	CONN1708, C2739 -> R3834 -> IC7701	I2S3 Bit CLock from CD player (record n=2) (CDR775 only)
I2S_BCLK_MIC	CONN1708, C2739 -> R3834 -> IC7701	I2S3 Bit CLock from MICrophone (CDR950 only)
I2S_DATA_AI	IC7406 -> IC7701	I2S4 DATA from CODEC (ADC for CDR950) Analog Input (record from analog source)
I2S_DATA_AO	IC7701 -> R3894C -> IC7406	I2S2 DATA for CODEC (DAC for CDR950) Analog Output
I2S_DATA_CD	CONN1708, C2738 -> R3836 -> IC7701	I2S3 DATA from CD player (record n=2) (CDR775 only)
I2S_DATA_MIC	CONN1708, C2738 -> R3836 -> IC7701	I2S3 DATA from MICrophone (CDR950 only)
I2S_WS_AI	IC7701 -> R3743 -> IC7406	I2S4 Word CLock for CODEC (ADC for CDR950) Analog Input (record from analog source)
I2S_WS_AO	IC7701 -> R3894B -> IC7406	I2S2 Word CLock for CODEC (DAC for CDR950) Analog Output
I2S_WS_CD	CONN1708, C2740 -> R3833 -> IC7701	I2S3 Word CLock from CD player (record n=2) (CDR775 only)
I2S_WS_MIC	CONN1708, C2740 -> R3833 -> IC7701	I2S3 Word CLock from MICrophone (CDR950 only)
I2S1_MS	IC7270 -> R3910, IC7701	I2S1 Master-Slave interrupt from MACE2
IE	T7121 -> CONN1000	laser Erase drive current signal
INT_COPY_ANA	IC7701 -> R3721 -> IC7401IC7701 -> R3721 -> R3410	select INTernal COPY ANALog (in case of copy protected disc or track on CD drive) (CDR775 only)
IR	T7135 -> CONN1000T7135 -> R3056T7135 -> IC7008	laser Read drive current signal
IW	T7122 -> CONN1000T7122 -> D6003	laser Write drive current signal
KEY_PRESSED	IC7706B -> R3816 -> IC7701	KEY PRESSED interrupt
KILL	T7560, T7561, R3560 -> CONN1400, R3424, R3428	KILL signal from power supply part to audio outputs
KILL_OUT	IC7701 -> R3532	disables the KILL activity from the PSU; 1 = no kill, 0 = kill active
L12V	supply voltage	+12V supply voltage for servo/Laser part
L3_CLK	IC7701 -> R3725 -> IC7406	L3 interface CLock line / control CODEC (not for CDR950)
L3_DATA	IC7701 <-> R3728 <-> IC7406	L3 interface DATA line with CODEC (not for CDR950)
L3_MODE	IC7701 -> R3735 -> IC7406	L3 interface MODE line selects data or address transfer mode for CODEC (not for CDR950)
L5V	supply voltage	+5V supply voltage for servo/Laser part
L-5V	supply voltage	-5V supply voltage for servo/Laser part
LASCK	IC7270 <-> R3248D	Clock line DAC LASer control
LASDACCK	R3248D <-> IC7016	Clock line DAC LASer control
LASDACDI	R3248C <-> IC7016	Data line DAC LASer control
LASDACLD	R3212 <-> IC7016	LoaD line DAC LASer control
LASDD	IC7270 <-> R3248C	Data line DAC LASer control
LASLD	IC7270 <-> R3238 <-> R3212IC7270 <-> R3232	LoaD line DAC LASer control
LEFT	CONN1708, C2743 -> IC7401C, IC7407C	audio output LEFT channel from CD-player in CDR775
LLP	IC7270 -> IC7300	Laser Low Power (active high), switches the laser from write to read power whenever the device tends to go offtrack

LWRT	R3048 -> IC7008	Laser WRITe control input
MA(16:17)	IC7270 <-> IC7208	bank switch higher address lines
MA(8:15)	IC7270 <-> IC7802 <-> IC7208	address bus high byte
MACE2		Mini All Cd Engine (minus decoder + OPC + PCS + extra RAM)
MAD(0:7)	IC7270 <-> IC7209 <-> IC7802 <-> IC7208 <-> IC7300	bi-directional data bus / address bus low byte
MIRN	IC7010 -> IC7270	MIRror Normalized (disc reflection) current output
MOTO1	IC7300 -> IC7355A	turn table MOTOr control output
MRDN	IC7270 -> R3276 -> R3242A, IC7802, IC7300	Master ReaD, read strobe for external peripherals, active low
MUTE	IC7270 -> R3718, R3723IC7270 -> IC7701	MUTE control from MACE2 to DASP, active low
MWRN	IC7270 -> R3280 -> R3242B, IC7802, IC7300	Master WRite, write strobe for external peripherals, active low
NMUTE	IC7701 -> R3726, IC7406	MUTE output, low active
OFFTRACK	IC7270 -> IC7300	OFFTRACK detection flag
OPC		Optimum Power Calibration
P12VKILL	supply voltage	+12V supply voltage for KILL-circuit
PCS		Position Control Sledge
PCSCOS	IC7225B, C2229 -> IC7270, CONN1812	Position Control Sledge COS feedback signal
PCSSIN	IC7225A, C2227 -> IC7270, CONN1812	Position Control Sledge SIN feedback signal
PDAR		Photo Diode Amplifier Recordable
PERASE	R3036, R3031, R3030, R3029, R3028, R3027, R3020 -> IC7002C, R3043, T7113	laser Power switch for ERASE
POWER_UP	IC7270 -> R3243C, R3556, R3538	standby pin, high level activates essential powers necessary for full function; overrules HI_POWER setting
PPN	IC7010 -> IC7050C	Push-Pull signal, Normalized, balanced, voltage output
PRCOARSE	IC7016 -> R3057	drive signal from Power Read COARSE DAC for read current source
PRFINE	IC7016 -> R3058	drive signal from Power Read FINE DAC for read current source
PROF_EBU	IC7701 -> CONN1820	PROFessional digital output (CDR950 only)
PSEn	IC7270 -> R3260 -> IC7208IC7270 -> R3231	Program Store ENable; external ROM output enable line, active low
PW	R3081 -> IC7008	Write Power signal to OPC input of MACE2
PWB	IC7001C -> IC7016	drive signal to XDAC<->s for write and erase current sources and VCAGAIN
PWD	IC7016 -> IC7002BIC7016 -> IC7002C	drive signal from XDAC for write and erase current sources
PWMAX	IC7016 -> R3073	PW MAXimum signal from DAC used for determining set point for laser power during writing
PWMIN	IC7016 -> R3072	PW MINimum signal from DAC used for determining set point for laser power during writing
PWRITE	R3035, R3026, R3025, R3024, R3023, R3022, R3021 -> IC7002B, R3044, T7124	laser Power switch for WRITE
RAD-	IC7240 -> CONN1000	Radial actuator drive signal negative connection
RAD+	IC7240 -> CONN1000	Radial actuator drive signal positive connection
RAS0	IC7701 -> IC7702	Row Address Strobe DRAM
RCK	IC7300 -> R3319 -> IC7701	EIAJ subcode clock from CDR60 to DASP (CD text interface)
RDGAIN1	IC7008 -> R3054	forward sense ReaD GAIN switch 1
RDGAIN2	IC7008 -> C2027	forward sense ReaD GAIN switch 2
RDGAIN3	IC7008 -> C2060	forward sense ReaD GAIN switch 3
RE	IC7010 -> IC7215A	Radial Error signal for fast track counting, voltage output
RECORDING	IC7008 -> IC7010IC7008 -> CONN1000IC7008 -> IC7355C	RECORDING output (active high)
REN	IC7010 -> IC7270	Radial Error Normalized current output
RIGHT	CONN1708, C2742 -> IC7401A, IC7407A	audio output RIGHT channel from CD-player in CDR775
RXD_TOOL	CONN1818 -> IC7701	Receive of UART for test TOOL
S1V65	Reference Voltage	1.65V delivered by IC7215B for Servo part
S2V9	Reference Voltage	2.9V delivered by IC7010 for Servo part
SEL_HP_OUT	IC7701 -> R3720 -> IC7407	SElect HeadPhone OUTput in DJ-mode (for CDR775 only)
SFSY	IC7701 -> R3756 -> IC7300	EIAJ subcode synchronisation from DASP to CDR60 (CD text interface)
SIN-	CONN1220 -> IC7225A	Hall feedback signal from sledge motor
SIN+	CONN1220 -> IC7225A	Hall feedback signal from sledge motor
SL-	IC7240 -> R3265 -> CONN1220	SLedge motor drive signal negative connection
SL+	IC7240 -> CONN1220	SLedge motor drive signal positive connection

SRSTN	IC7270 -> R3243B, IC7300	Slave ReSeT out (CDR60 reset), active low
STANDBY	IC7270 -> R3807 -> R3887 -> IC7701	STANDBY pin, high level activates essential powers necessary for full function; overrules HI_POWER setting
SUB	IC7701 -> R3710 -> IC7300	EIAJ subcode data from DASP to CDR60 (CD text interface)
SYS_CLK_11W	IC7701 -> R3732 -> IC7406	11.2896 MHz SYStem CLock for AD/DA datapath
SYS_CLK_16W	IC7701 -> R3894D-> IC7706A	16.9344 MHz SYStem CLock for producing SYS_CLK_BE
SYS_CLK_8W	IC7706A -> R3815 -> CONN1708	SYStem CLock CD player (8.4672 MHz) (CDR775 only)
SYS_CLK_BE	IC7706A -> R3826 -> IC7270	SYStem CLock Basic Engine (8.4672 MHz)
SYS_RESET	IC7701 -> R3758 -> CONNF934IC7701 -> R3770 -> T7707 -> CONN1708	SYStem RESET to display assy (and CD player for CDR775)
TCK	CONN1819 -> R3906, IC7701	JTAG Clock signal
TDSO	IC7701 -> CONN1819	JTAG Serial Data Out / debug data out
TERMB	IC7270 <-> CONN1818	UART connection with MACE
TLN	IC7010 -> IC7270	Track Loss Normalized current output
TR-	IC7240 -> CONN1200	TRay motor drive signal negative connection
TR+	IC7240 -> CONN1200	TRay motor drive signal positive connection
TRACE99_RXD	CONN1818 -> R3838, IC7701	TRACE99 test tool receive data
TRACE99_TXD	IC7701 -> CONN1818	TRACE99 test tool transmit data
TRAYIN	IC7270 -> IC7240	move TRAY IN line, active low
TRAYOUT	IC7270 -> IC7240	move TRAY OUT line, active low

TRAYSW	CONN1200 -> R3747CONN1200 -> R3748	TRAY SWitch signal from loader assy
TRAYSWF	R3748, C2214 -> IC7270	Filtered TRAY SWitch signal, low is completely out or in
TXD_TOOL	IC7701 -> CONN1818	Transmit of UART for test TOOL
U+, U-, V+, V-, W+, W-	CONN1330 -> IC7330	hall feedback signals from turn table motor to hall motor driver
UCOIL, VCOIL, WCOIL	IC7330 -> CONN1330	drive signals for turn table motor
VCAGAIN	IC7016 -> IC7005A	set-point laser power on disc, voltage output
VDC1	CONN1500 -> CONNF934	supply voltage for display assy
VDC2	CONN1500 -> CONNF934	supply voltage for display assy
VFO	IC7270 -> R3295 -> R3244	FOcus actuator drive output
VFTD	CONN1500 -> CONNF934	Voltage Fluorescent Tube Display (display assy)
VRA	IC7270 -> R3297 -> R3254	RAdial actuator drive output
VSL	IC7270 -> R3299 -> IC7240	SLedge actuator drive output
WCLK	IC7701 -> R3898B -> IC7300	I2S1 WordCLock from DASP to CDR60 (playback and record)
WOBBLE	IC7050C -> IC7300	analog WOBBLE signal of pre-groove detected by PPN-signal
WPON	IC7008 -> R3009IC7008 -> C2009	Write Power ON
WPONO	IC7008 -> R3106	Write Power ON Open drain output
WPONRC	R3003 -> CONN1000	Write Power ON (after RC circuit)
XDAC		multiplying DAC

1. Technical Specifications CDR600

1.1 General

Mains voltage	: all range version 84-250V (/00), : USA version 117V/60Hz (/17)
Mains frequency	: 50-60 Hz
Power consumption	: 15W

S/N-ratio A-weighted	: > 98dB (typical 102dB)
S/N-ratio unweighted	: > 93dB (typical 95dB)
Dynamic range	: > 92dB at 1kHz (typical 96dB)
	: > 90dB between 20Hz and 20kHz (typical 96dB)
THD+N	: > 82dB between 20Hz and 20kHz (typical 88dB)

1.2 Input/Output

1.2.1 Line output

Output level	: 2Vrms at 0dB
Output resistance	: 200Ω

1.2.2 Line input

Input sensitivity	: 500mVrms
Input impedance	: 50kΩ
Max. input voltage	: 2.5Vrms

1.2.3 Digital output

Format	: AES/EBU format according IEC958 (consumer format)
Sampling frequency	: 44.1kHz
Output resistance	: 75Ω

1.2.4 Digital input

Format	: AES/EBU format according IEC958 (consumer format)
Sampling frequency	: 32 to 96kHz
Input resistance	: 75Ω

1.2.5 Optical input

Format	: AES/EBU format according IEC958 (consumer format)
Sampling frequency	: 32 to 48kHz

1.3 Audio Performance

1.3.1 Cinch analog output (play-back path)

Output voltage	: 2Vrms ± 2dB (0dB signal)
Frequency range F.R.	: 20Hz < F.R. < 20kHz
Amplitude linearity	: ±0.3dB (typical ±0.1dB)
Channel unbalance	: < 0.3dB at 1kHz (typical ± 0.2dB)
Output resistance	: 200Ω
Phase non-linearity	: < 0.2 deg at 1kHz
Outband attenuation	: 50dB above 30kHz
Channel separation	: > 90dB at 1kHz (typical 110dB)
	: > 85dB between 20Hz and 20kHz (typical > 93dB)

1.3.2 Cinch analog input/output (monitor path)

Measured with Audio precision system one.

Input voltage is 500Vrms.

Output voltage	: 2Vrms ± 2dB (0dB signal)
Frequency range F.R.	: 20Hz < F.R. < 20kHz
Amplitude linearity	: ± 0.3dB (typical ± 0.1dB)
Channel unbalance	: < 0.3dB at 1kHz (typical ± 0.2dB)
Output resistance	: 200Ω
Phase non-linearity	: < 0.2 deg at 1kHz
Outband attenuation	: 50dB above 30kHz
Channel separation	: > 90dB at 1kHz (typical 98dB)
	: > 85dB between 20Hz and 20kHz (typical > 92dB)
S/N-ratio unweighted	: > 84dB (typical 88dB)
Dynamic range	: > 82dB at 1kHz (typical 90dB)
THD+N	: > 80dB between 20Hz and 20kHz (typical 85dB)
Intermodulation THD	: > 80dB

1.3.3 Headphone output (all functions)

Output voltage	: 3Vrms (0dB)/8-2000Ω
S/N	: > 80dB
THD+N	: > 75dB
Channel separation	: > 60dB between 20Hz and 20kHz

1.4 Laser Device

Material	: GaAlAs
Wave length	: between 780 and 800nm (at 25°C)
Laser output	: 1mW max. during reading, 20mW max. during writing
Class	: 3B

1.5 Dimensions and Weight

Number and height of feet	: 4x11mm foiled
Apparatus tray closed (WxDxH)	: 435x305x75mm (without feet)
Weight without packaging	: 3.2kg
Weight with packaging	: 4.2kg

2. Warnings and Servicing Hints

GB WARNING

All ICs and many other semi-conductors are susceptible to electrostatic discharges (ESD). Careless handling during repair can reduce life drastically.

When repairing, make sure that you are connected with the same potential as the mass of the set via a wrist wrap with resistance.

Keep components and tools also at this potential.

ESD



NL WAARSCHUWING

Alle IC's en vele andere halfgeleiders zijn gevoelig voor elektrostatische ontladingen (ESD).

Onzorgvuldig behandelen tijdens reparatie kan de levensduur drastisch doen verminderen.

Zorg ervoor dat u tijdens reparatie via een polsband met weerstand verbonden bent met hetzelfde potentiaal als de massa van het apparaat.

Houd componenten en hulpmiddelen ook op ditzelfde potentiaal.

F ATTENTION

Tous les IC et beaucoup d'autres semi-conducteurs sont sensibles aux décharges statiques (ESD).

Leur longévité pourrait être considérablement écourtée par le fait qu'aucune précaution n'est prise à leur manipulation.

Lors de réparations, s'assurer de bien être relié au même potentiel que la masse de l'appareil et enfiler le bracelet serti d'une résistance de sécurité.

Veiller à ce que les composants ainsi que les outils que l'on utilise soient également à ce potentiel.

D WARNUNG

Alle IC und viele andere Halbleiter sind empfindlich gegen elektrostatische Entladungen (ESD).

Unvorsichtige Behandlung bei der Reparatur kann die Lebensdauer drastisch vermindern. Sorgen Sie dafür, dass Sie im Reparaturfall über ein Pulsarmband mit Widerstand mit dem Massepotential des Gerätes verbunden sind.

Halten Sie Bauteile und Hilfsmittel ebenfalls auf diesem Potential.

I AVVERTIMENTO

Tutti IC e parecchi semi-conduttori sono sensibili alle scariche statiche (ESD).

La loro longevità potrebbe essere fortemente ridotta in caso di non osservazione della più grande cauzione alla loro manipolazione.

Durante le riparazioni occorre quindi essere collegato allo stesso potenziale che quello della massa dell'apparecchio tramite un braccialetto a resistenza.

Assicurarsi che i componenti e anche gli utensili con quali si lavora siano anche a questo potenziale.

GB

Safety regulations require that the set be restored to its original condition and that parts which are identical with those specified be used.

NL

Veiligheidsbepalingen vereisen, dat het apparaat in zijn oorspronkelijke toestand wordt terug gebracht en dat onderdelen, identiek aan de gespecificeerde worden toegepast.

F

Les normes de sécurité exigent que l'appareil soit remis à l'état d'origine et que soient utilisées les pièces de rechange identiques à celles spécifiées.

D

Bei jeder Reparatur sind die geltenden Sicherheitsvorschriften zu beachten. Der Originalzustand des Gerats darf nicht verändert werden. Für Reparaturen sind Original-Ersatzteile zu verwenden.

I

Le norme di sicurezza esigono che l'apparecchio venga rimesso nelle condizioni originali e che siano utilizzati pezzi di ricambio identici a quelli specificati.

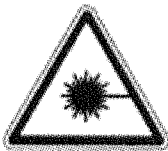

**CAUTION
VARO!
WARNING
ADVERSE!
DANGER
VORSICHT**

VISIBLE LASER RADIATION WHEN OPEN. AVOID EXPOSURE TO BEAM.

AVATTIENSA OLLET ALTTIINA NÄKYMÄTTÖMÄLLÄ LASER SÄTEILYLLÄ ÄLÄ KATSO SÄTEESIN.

OSYNEG LASERSTRÄLNING NÄR DENNA DEL ÄR ÖPPNAD BETRÄKTA EJ STRÄLEN.

OSYNEG LASERSTRÄLNING VID ÖPPNING. UNDGA ONSÄTTTELSE FOR STRÄLNING.

VISIBLE LASER RADIATION WHEN OPEN. AVOID DIRECT EXPOSURE TO BEAM.

UNSICHTBARE LASERSTRÄHLUNG WENN ABEDECKUNG GEÖFFNET. NICHT DEM STRAHL AUSSETZEN.

SHOCK, FIRE HAZARD SERVICE TEST:

CAUTION: After servicing this appliance and prior to returning to customer, measure the resistance between either primary AC cord connector pins (with unit NOT connected to AC mains and its Power switch ON), and the face or Front Panel of product and controls and chassis bottom,

Any resistance measurement less than 1 Megohms should cause unit to be repaired or corrected before AC power is applied, and verified before return to user/customer.

Ref. UL Standard NO. 1492.

NOTE ON SAFETY:

Symbol : Fire or electrical shock hazard. Only original parts should be used to replace any part with symbol Any other component substitution (other than original type), may increase risk or fire or electrical shock hazard.

"Pour votre sécurité, ces documents doivent être utilisés par des spécialistes agréés, seuls habilités à réparer votre appareil en panne."

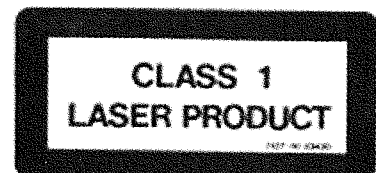

SERVICING HINTS

In the set, chip components have been applied. For disassembly and assembly check the figure below.

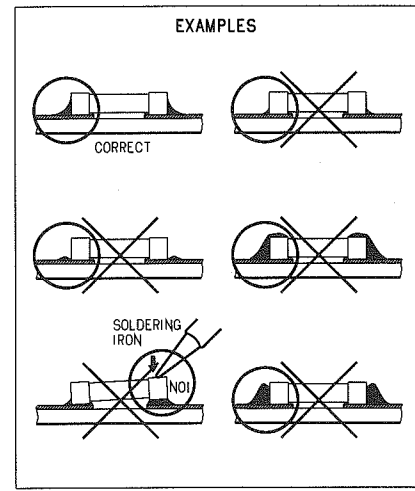
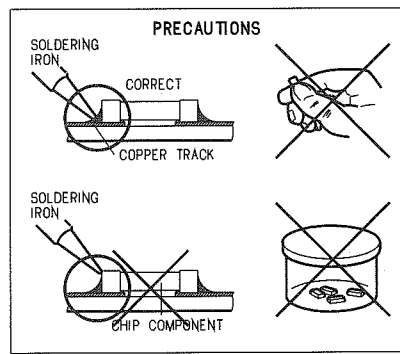
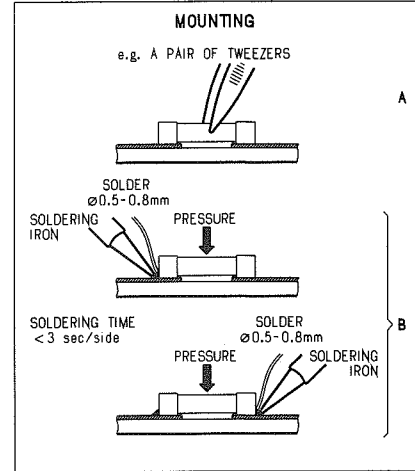
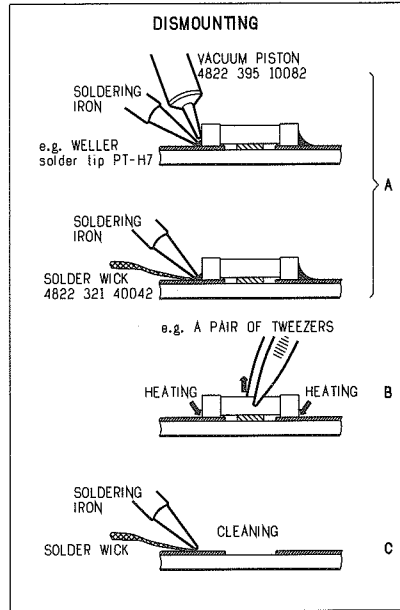
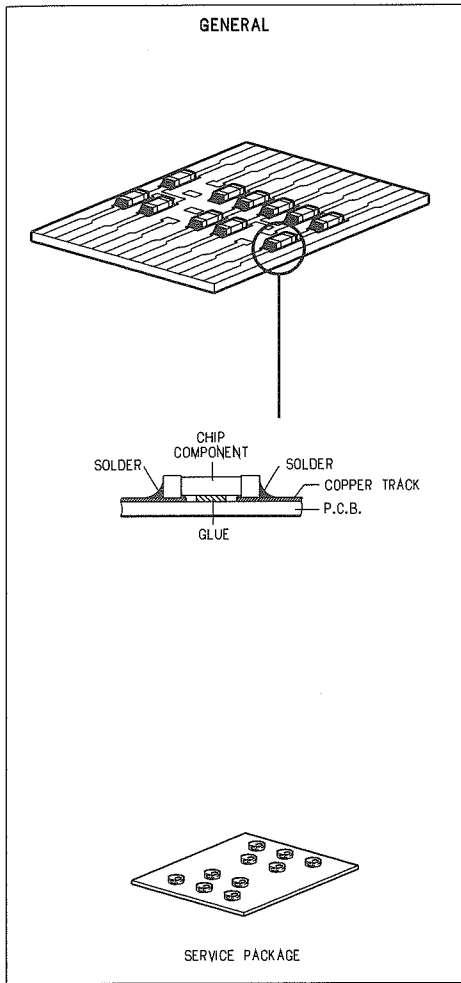

SAFETY GUIDELINES FOR THE PROFESSIONAL SERVICE TECHNICIAN

Important

Proper service and repair is important to the safe, reliable operation of all Philips equipment. The service procedures recommended by Philips and described in this service manual are effective methods of performing service operations. Some of these service operations require the use of tools specially designed for the purpose. The special tools should be used when and as recommended.

It is important to note that this manual contains various CAUTIONS and NOTICES which should be carefully read in order to minimize the risk of personal injury to service personnel. The possibility exists that improper service methods may damage the equipment. It also is important to understand that these CAUTIONS and NOTICES ARE NOT EXHAUSTIVE. Philips could not possibly know, evaluate and advise the service trade of all conceivable ways in which service might be done or of the possible hazardous consequences of each way. Consequently, Philips has not undertaken any such broad evaluation. Accordingly, a servicer who uses a service procedure or tool which is not recommended by Philips must first satisfy himself thoroughly that neither his safety nor the safe operation of the equipment will be jeopardized by the service method selected.

Safety Checks

After the original service problem has been corrected, a complete safety check should be made. Be sure to check over the entire set, not just the areas where you have worked. Some previous servicer may have left an unsafe condition, which could be unknowingly passed on to your customer. Be sure to check all of the following:

Fire and Shock Hazard

1. Be sure all components are positioned in such a way as to avoid the possibility of adjacent component shorts. This is especially important on those units which are transported to and from the service shop.
2. Never release a repaired unit unless all protective devices such as insulators, barriers, covers, strain reliefs, and other hardware have been installed according to the original design.
3. Soldering and wiring must be inspected to locate possible cold solder joints, solder splashes, sharp solder points, frayed leads, pinched leads, or damaged insulation (including the ac cord). Be certain to remove loose solder balls and all other loose foreign particles.
4. Check across-the-line components and other components for physical evidence of damage or deterioration and replace if necessary. Follow original layout, lead length, and dress.
5. No lead or component should touch a resistor rated at 1 watt or more. Lead tension around protruding metal surfaces or edges must be avoided.
6. Critical components having special safety characteristics are identified with a Δ by the Ref. No. in the parts list and enclosed within a broken line* (where several critical components are grouped in one area) along with the safety symbol Δ on the schematic diagrams and/or exploded views.

Replacement parts without the same safety characteristics may create shock, fire, or other hazards.

7. When servicing any unit, always use a separate isolation transformer for the chassis. Failure to use a separate isolation transformer may expose you to possible shock hazard, and may cause damage to servicing instruments.
8. Many electronic products use a polarized ac line cord (one wide pin on the plug). Defeating this safety feature may create a potential hazard to the servicer and the user. Extension cords which do not incorporate the polarizing feature should never be used.

Fire and Shock Hazard (Continued)

9. After reassembly of the unit, always perform an ac leakage test or resistance test from the line cord to all exposed metal parts of the cabinet. Also, check all metal control shafts (with knobs removed), antenna terminals, handles, screws, etc. to be sure the unit is safe to operate without danger of electrical shock.

* Broken line: 

Leakage Current Cold Check

1. Unplug the ac line cord and connect a jumper between the two prongs of the plug.
2. Turn on the power switch.
3. Measure the resistance value between the jumpered ac plug and all exposed cabinet parts of the receiver, such as screw heads, antennas, and control shafts. When the exposed metallic part has a return path to the chassis, the reading should be between 1 megohm and 5.2 megohms. When the exposed metal does not have a return path to the chassis, the reading must be infinity. Remove the jumper from the ac line cord.

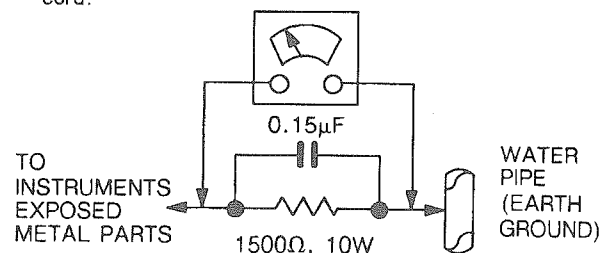
**Leakage Current Hot Check**

1. Do not use an isolation transformer for this test. Plug the completely reassembled unit directly into the ac outlet.
2. Connect a 1.5k, 10W resistor paralleled by a 0.15µF capacitor between each exposed metallic cabinet part and a good earth ground such as a water pipe, as shown above.
3. Use an ac voltmeter with at least 5000 ohms/volt sensitivity to measure the potential across the resistor.
4. The potential at any point should not exceed 0.75 volts. A leakage current tester may be used to make this test; leakage current must not exceed 0.5 millamps. If a measurement is outside of the specified limits, there is a possibility of shock hazard. The receiver should be repaired and rechecked before returning it to the customer.
5. Repeat the above procedure with the ac plug reversed. (Note: An ac adapter is necessary when a polarized plug is used. Do not defeat the polarizing feature of the plug.)

Parts Replacement

1. Many electrical and mechanical parts in Philips equipment have special safety related characteristics. These characteristics are often not evident from visual inspection nor can the protection afforded by them necessarily be obtained by using replacement components rated for higher voltage, wattage, etc. The use of a substitute part which does not have the same safety characteristics as the Philips recommended replacement part shown in this service manual may create shock, fire, or other hazards. Under no circumstances should the original design be modified or altered without written permission from Philips. Philips assumes no liability, express or implied, arising out of any unauthorized modification of design. Servicer assumes all liability.
2. All ICs and many other semiconductor parts are susceptible to electrostatic discharges (ESD). Careless handling during repair can reduce the life of the part drastically.

LASER NOTE:

DANGER - Invisible laser radiation when open. AVOID DIRECT EXPOSURE TO BEAM.

CAUTION - Use of controls or adjustments or performance of procedures other than those specified herein may result in hazardous radiation exposure.

CAUTION - The use of optical instruments with this product will increase eye hazard.

4. Mechanical Instructions

WIRING DIAGRAM

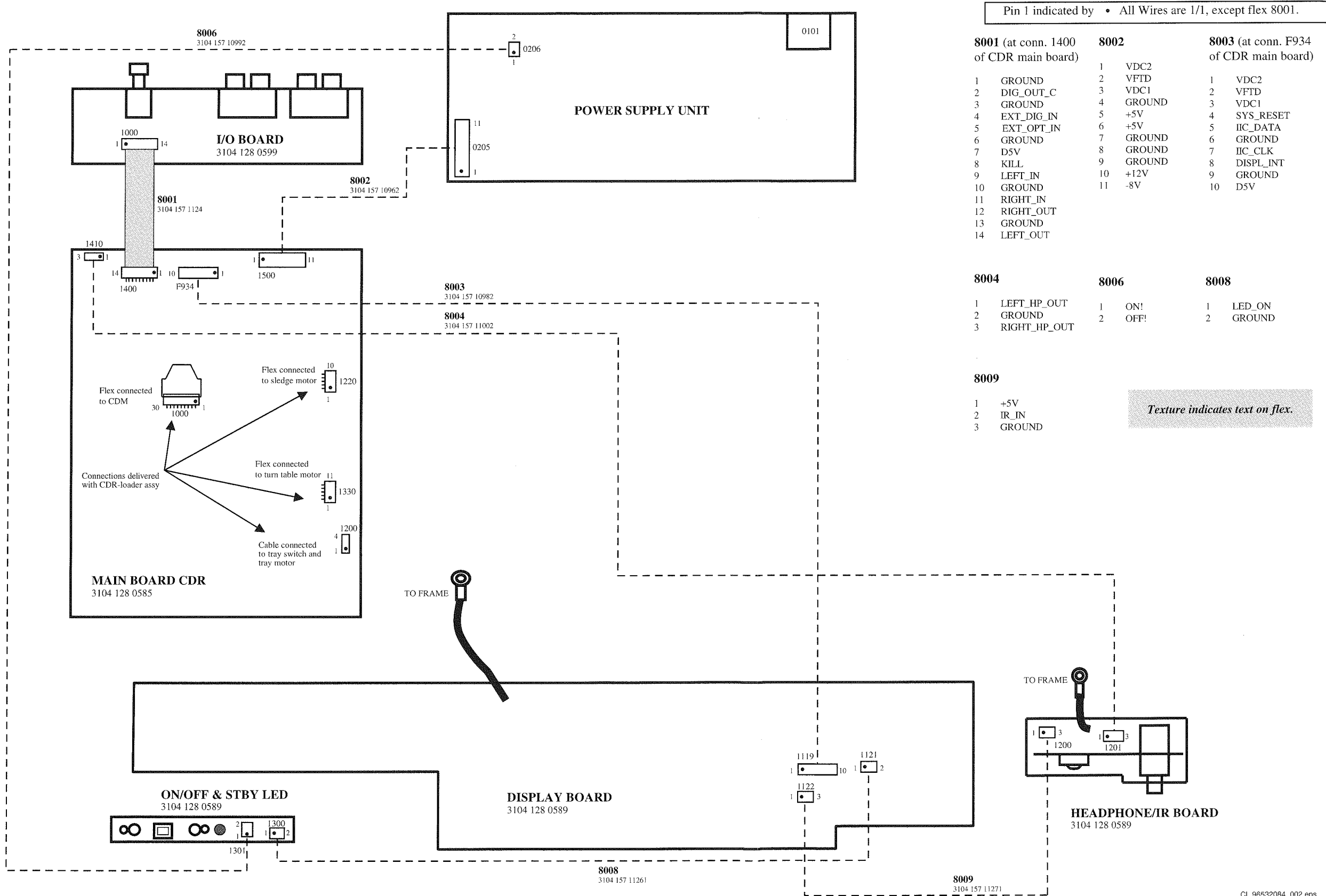

DISMANTLING INSTRUCTIONS

See Exploded View for item numbers

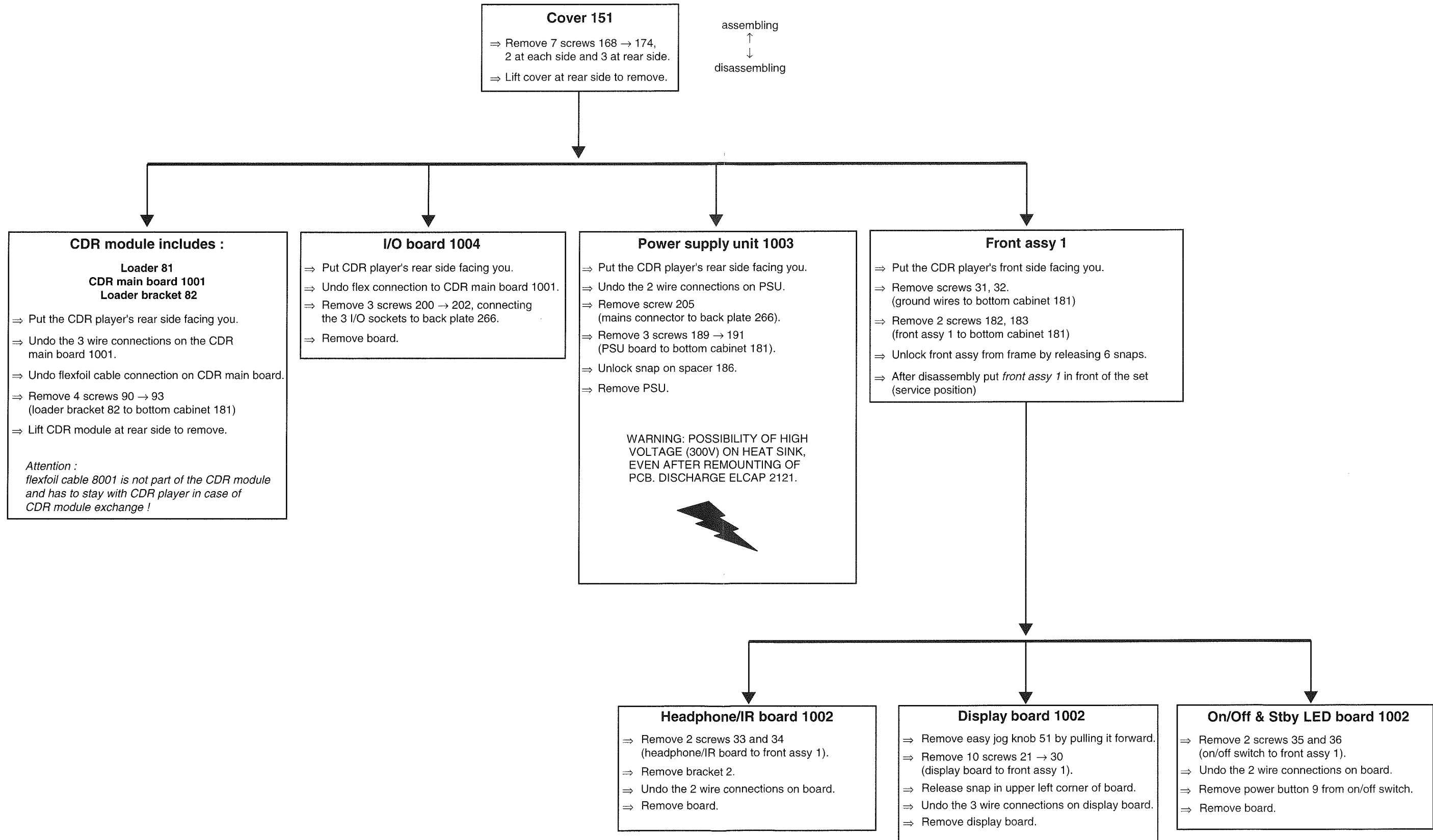

6. Diagnostic Software

6.1 Dealer mode

The purpose of the dealer mode is to prevent people taking out the CD inside the player at exhibitions, showrooms etc.. This mode disables the open/close function of the player.

The dealer mode can be switched on and off by pressing keys [OPEN/CLOSE] and [STOP] of the CDR player simultaneously while switching on the unit. The dealer mode is stored in the flash memory and can only be changed by executing the above actions.

6.2 Dealer diagnostics

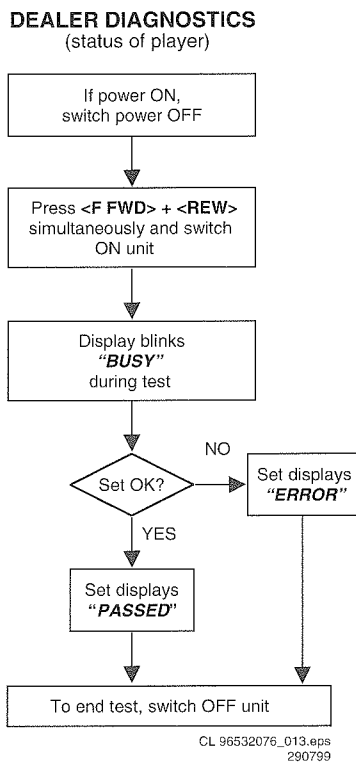

Figure 6-1

6.2.1 Description

The intention of the dealer diagnostics is to give an indication of the CDR player status. An inexperienced, even non-technical dealer will/can perform the test. Tests are executed automatically without need for external tools or disassembly of the unit. This test checks the CDR main board using the same tests as the electrical service diagnostics program. Only the result of the test, "PASSED" or "ERROR", will be shown on the display. Pressing keys [F FWD] and [REWIND] simultaneously while switching on the unit, starts the test. Switching off the unit ends the test.

6.2.2 Requirements to perform the test

- Working keyboard to start up the test.
- Working local display to check the output messages.

6.3 Electrical service diagnostics

ELECTRICAL SERVICE DIAGNOSTICS
(software versions, test for defective components)

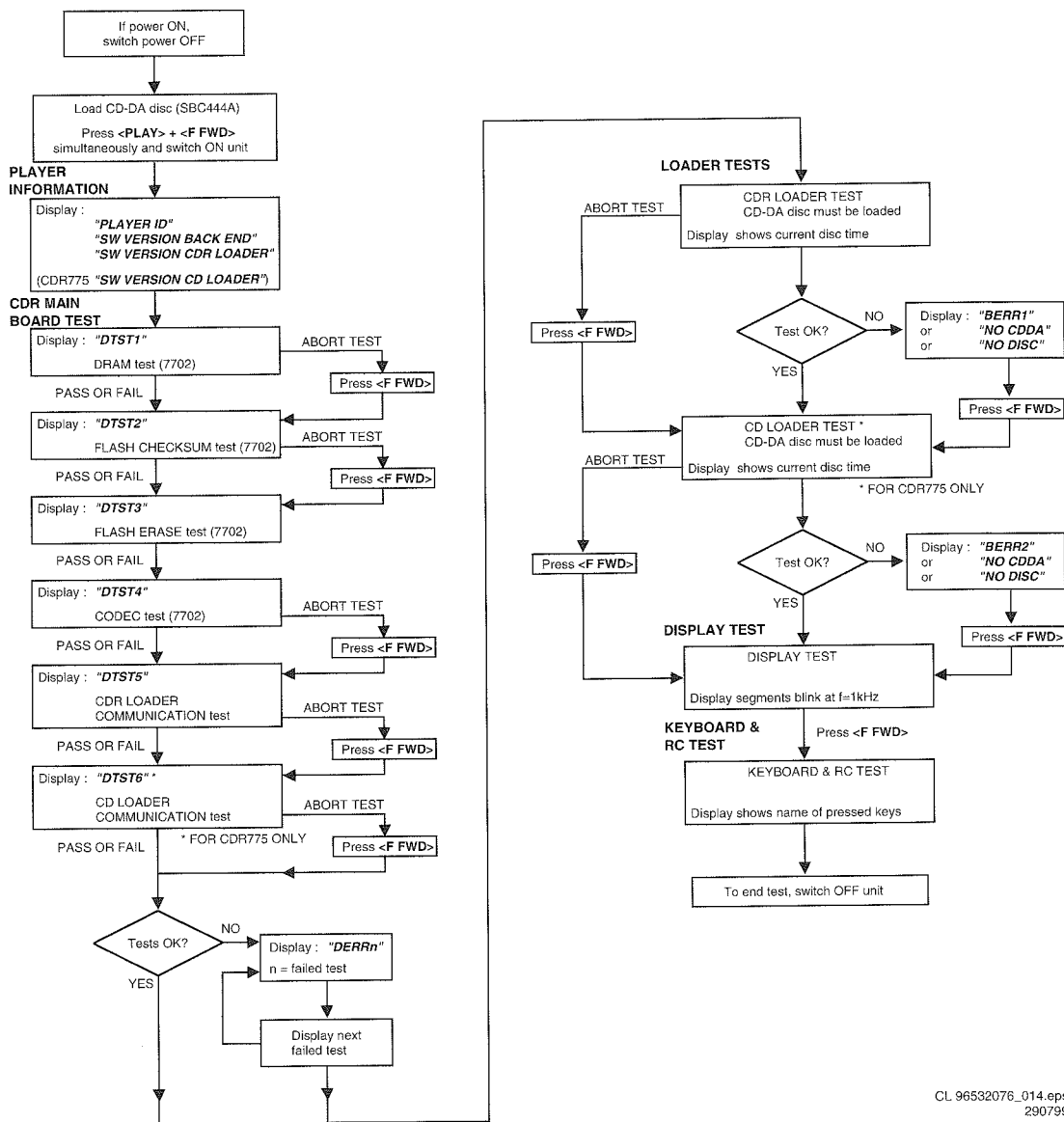

CL 96532076_014.eps
290799

Figure 6-2

6.3.1 Description

The intention of the electrical service diagnostics is to show the software versions present in the player and to direct the dealer towards defective internal units. The units are : the CDR main board, the CDR loader, the CD loader in case of a CDR775 and the keyboard/display board. A sequence of tests is executed automatically. Some of the tests can be aborted or skipped without the result being taken into account. External tools or disassembly of the unit is not necessary to get the diagnostic information. Pressing keys [PLAY/PAUSE] and [F FWD] simultaneously while switching on the unit, starts the test. Switching off the unit ends the test.

6.3.2 Requirements to perform the test

- Working keyboard to start up the test.
- Working local display to check the output messages.
- A CD-DA disc with a minimum of 3 tracks in all trays to perform the disc test.

6.3.3 Description of the tests

Player information

In this part of the test the following important information can be checked without removing the cover :

- Recorder ID.
- SW-version back end of player.
- SW-version CDR loader.
- SW-version CD loader (only for CDR775).

CDR main board test

As soon as the CDR main board tests are finished, all failure messages (if any) will be displayed sequentially by pressing the [F FWD] key. The message "DERRn" will be displayed with n indicating the faulty test number.

If one of the tests is aborted with the [F FWD] key, no error message will be displayed for this test. The flash data erase test ("DTST3") can not be aborted !

The CDR main board test consists out of :

DRAM test

Display : "DTST1". The DRAM used for buffer management is tested by writing, reading and verifying test patterns.

Flash checksum test

Display : "DTST2". This test checks the checksum of the player's SW stored in the flash.

Flash data erase

Display : "DTST3". During this test, all temporary information (CDtxt) in the flash is erased.

CODEC (ADC/DAC) test

Display : "DTST4". This test checks the CODEC IC by writing, reading and verifying test patterns. The test is not applicable for CDR950.

CDR communication test

Display : "DTST5". The communication between the host processor (DASP) and the CDR loader via the DSA-R-bus is tested.

CD communication test

Display : "DTST6". The communication between the host processor (DASP) and the CD loader is tested. The test is only applicable for CDR775.

Loader tests

These tests determine if the CDR loader and the CD loader in case of a CDR775 work correctly. A CD-DA disc with a minimum of 3 tracks needs to be inserted in both loaders. A disc test is executed to check focus control, disc motor control, radial control and jump grooves control. The disc test is performed by audio play-back of 5 seconds at the beginning, middle and end of the disc.

CDR loader test

During the test, the current disc time is shown. In case of an error the message "BERR1" will be displayed and the [F FWD] key must be pressed to continue with the following test. Pressing the [F FWD] key also aborts this test.

CD loader test

For CDR775 only. During the test, the current disc time is shown. In case of an error the message "BERR2" will be displayed and the [F FWD] key must be pressed to continue with the following test. Pressing the [F FWD] key also aborts this test.

Display test

All segments will blink at a frequency of 1 Hz. Pressing the [F FWD] key will start the next test because the user has to check for himself if all segments work properly.

Keyboard and remote control tests

The test will give the user the ability to test every key without executing the function assigned to it. Therefore, the user needs to press every key on the keyboard and the remote control. The display will show the name of the key being pressed. Pressing more than one key at once will give an unpredictable result except for the service combinations : [PLAY/PAUSE] + [STOP], [PLAY/PAUSE] + [F FWD], [F FWD] + [REWIND], [ERASE] + [RECORD], [PLAY/PAUSE] + [RECORD], [OPEN/CLOSE] + [PROGRAM].

6.4 Mechanical service diagnostics

Figure 6-3

6.4.1 Description

No external tools are required to perform this test. The cover needs to be removed because the user has to check the movements of the tray, focus and sledge visually. Pressing keys [PLAY/PAUSE] and [STOP] simultaneously while switching on the unit, starts the test. Switching off the unit ends the test. In case of a CDR775, one can check the CD loader mechanics in the same way by pressing the above key combination on the CD player keys.

6.4.2 Requirements to perform the test

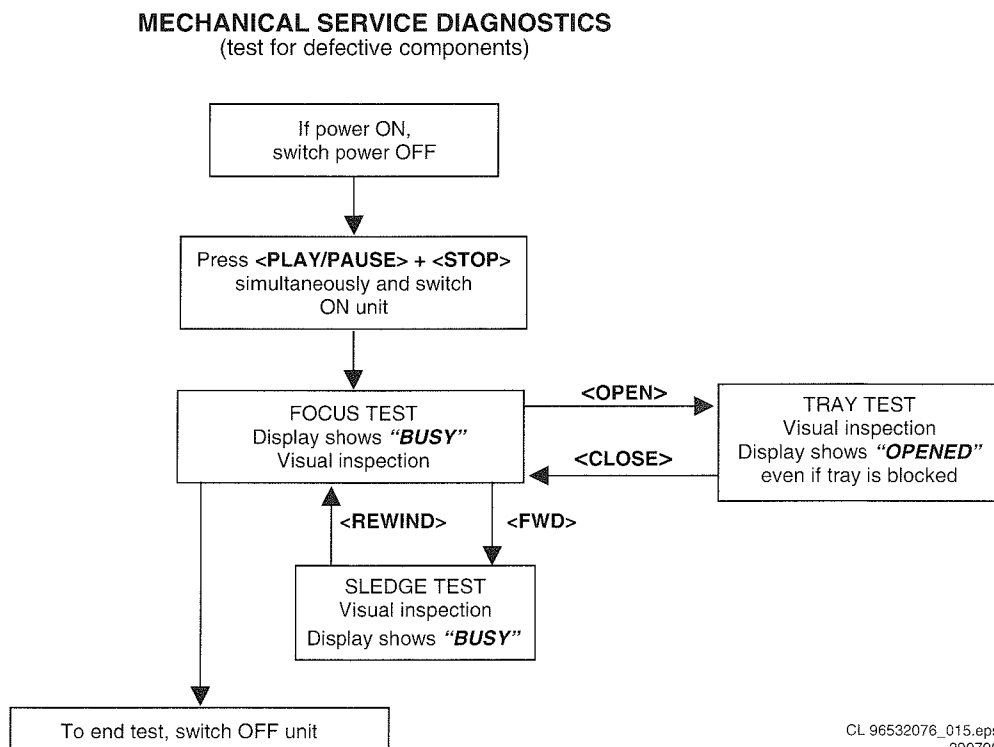
- Working keyboard to cycle through the tests and to start up the test.
- Working local display to check the output messages.

6.4.3 Description of the tests

Focus control test

The focussing lens is continuously moving up and down. The display reads "BUSY".

Sledge control test

After pressing [F FWD] the sledge continuously moves up and down. Pressing [REWIND] stops the sledge at the position it is in and the focus control test resumes. The display reads "BUSY".

Tray control test

This test starts from within the focus control test routine. Pressing [OPEN/CLOSE] moves the tray in or out. In the tray closed position one can initiate focus and sledge tests by pressing [F FWD]. One has to stop these tests pressing [REWIND] before it is possible to open the tray again. Depending on the action the display reads "OPEN", "OPENED", "CLOSE" or "BUSY".

6.5 DC-erase service mode

DC ERASE SERVICE MODE (erasure of complete CD-RW)

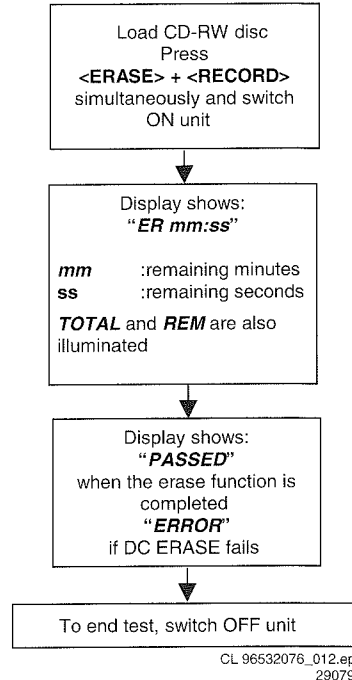

Figure 6-4

6.5.1 Description

This test is initiated by pressing [ERASE] and [RECORD] simultaneously while switching on the unit. The player will erase a complete CD-RW disc (including PMA and ATIP lead out area) at speed N=2. The display shows the countdown of the remaining time required for the operation to complete. The format is "ER mm:ss", where "mm" are the remaining minutes and "ss" the remaining seconds. After completion the message "PASSED" is shown, and the player has to be switched off and on again to start up in normal operating mode. Switching off the unit before completion of the test, leaves the disc in an unpredictable state. In such case only a complete DC-erase procedure can recover the CD-RW disc.

6.5.2 Requirements to perform the test

- Functional CDR player.
- A CD-RW audio disc must be present in the tray.

7. Faultfinding Trees

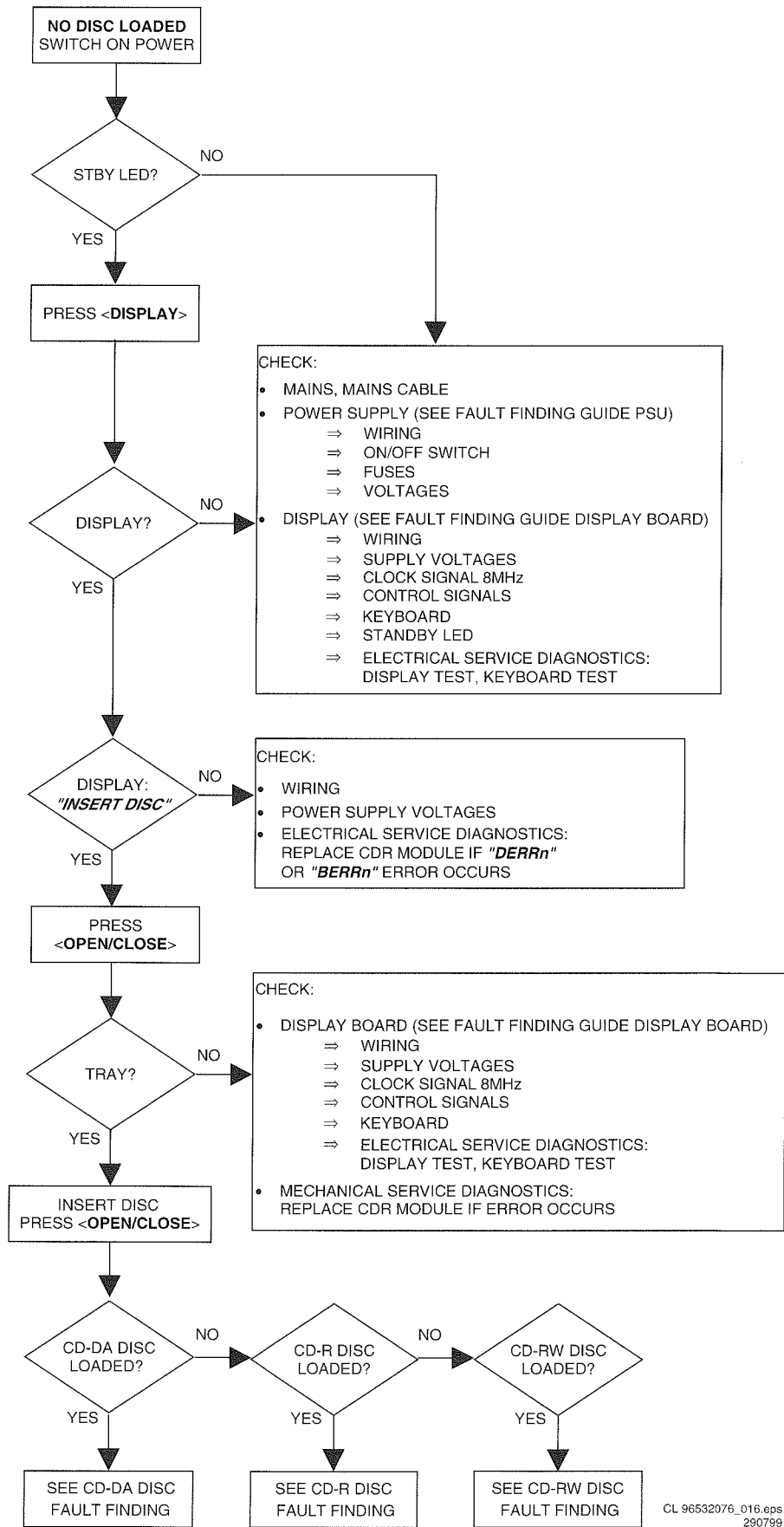

CL 96532076_016.eps
290799

Figure 7-1

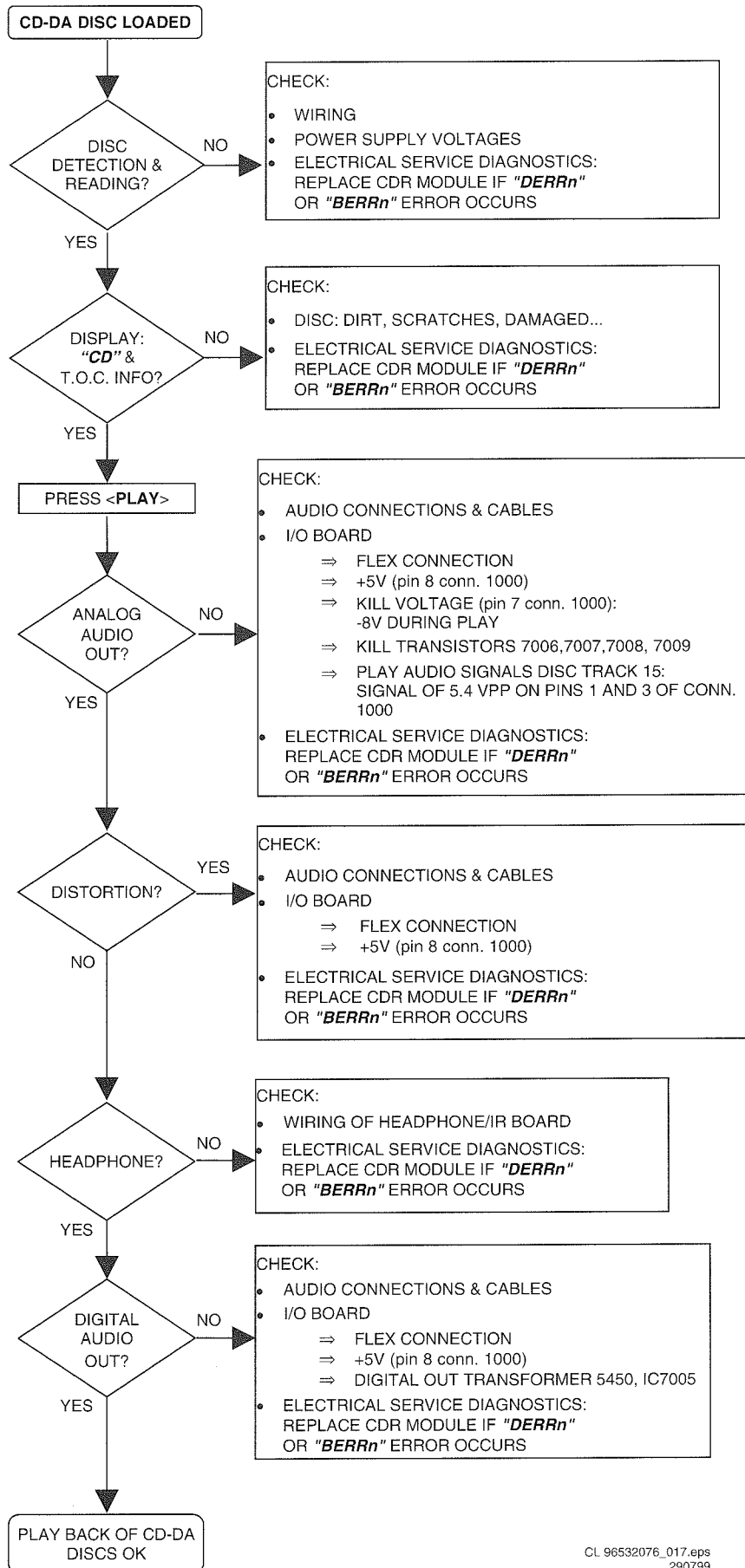

CL 96532076_017.eps
290799

Figure 7-2

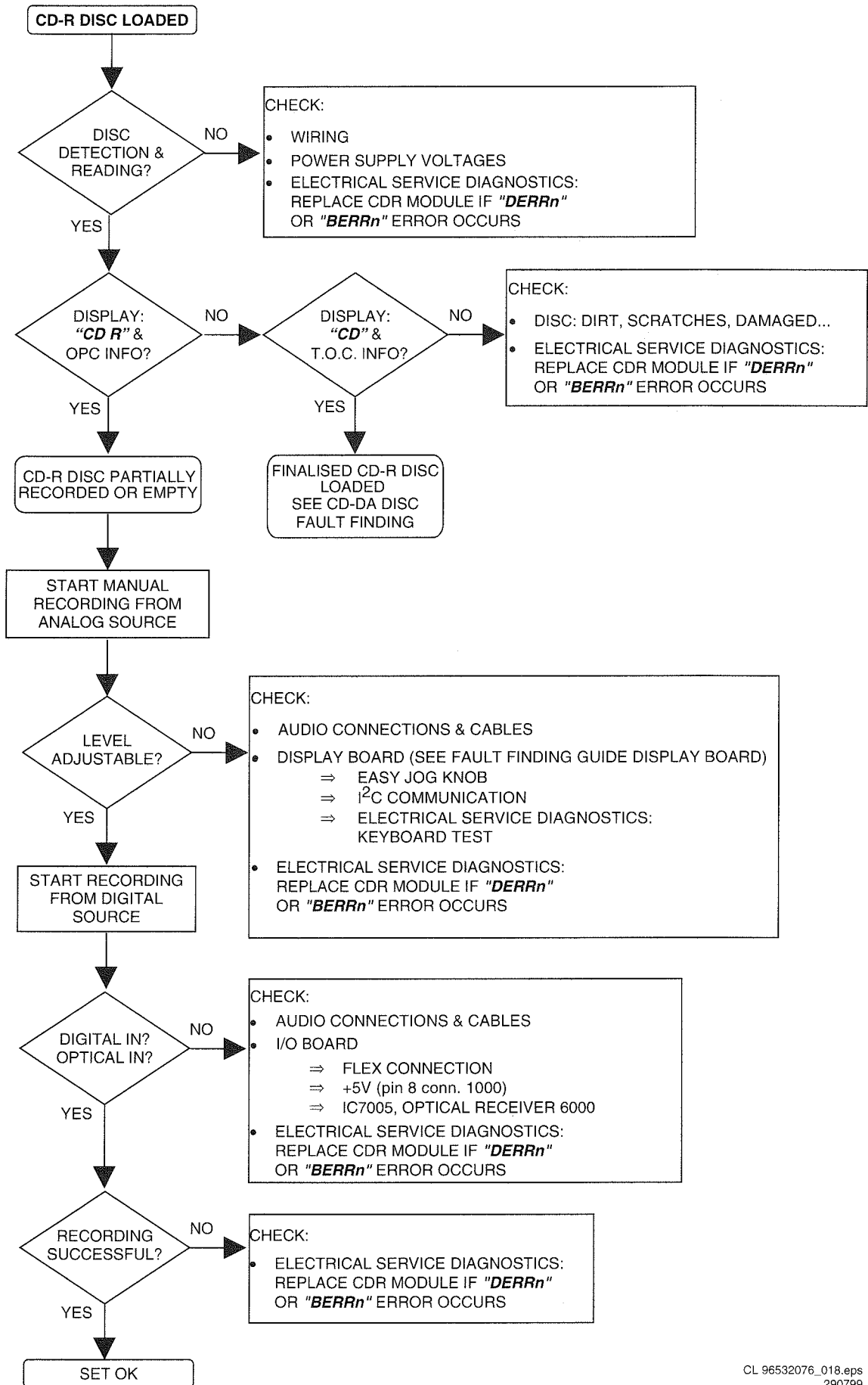

Figure 7-3

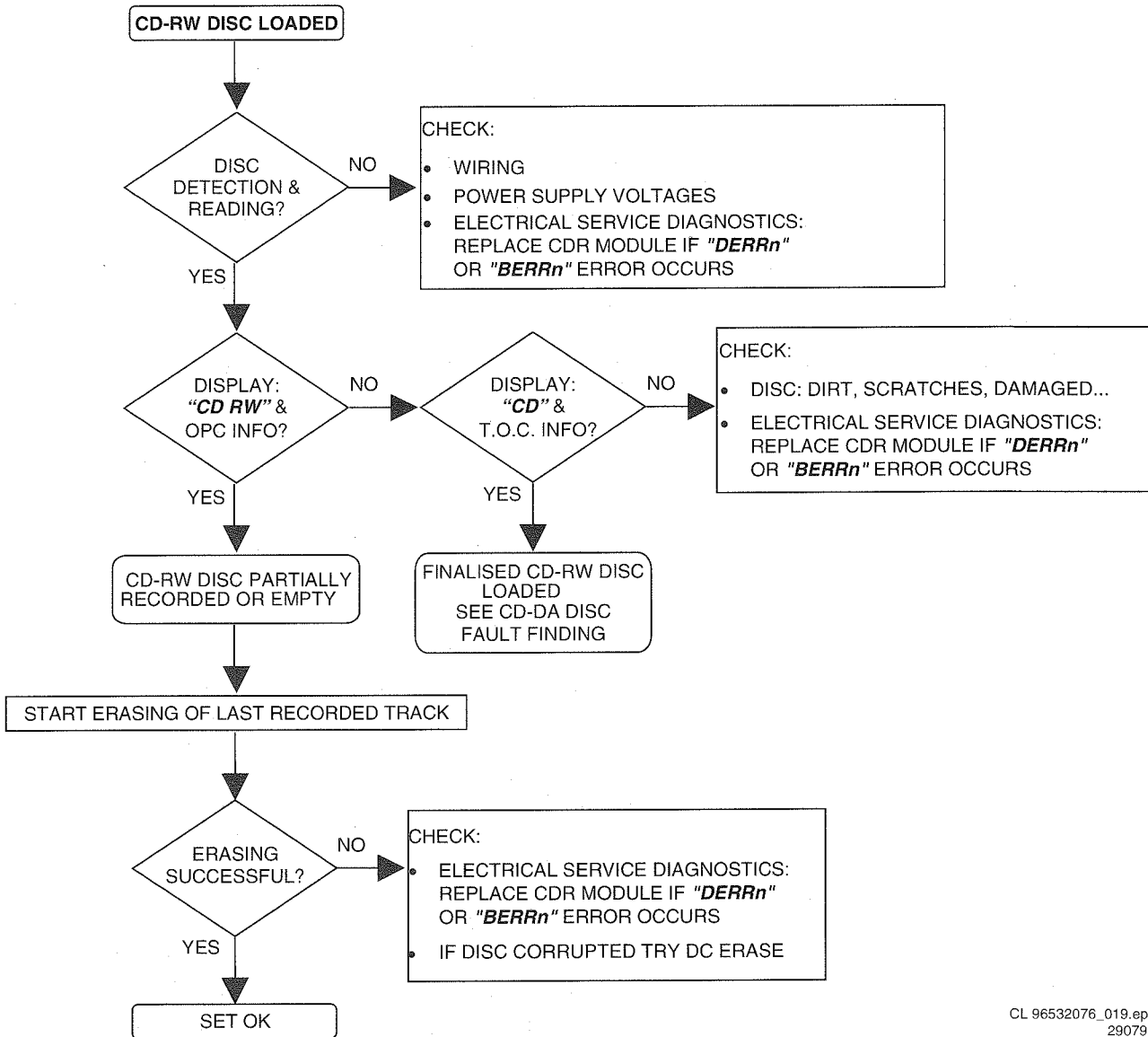

Figure 7-4