

# Bearcat®

## SERVICE MANUAL

### BC-220



**Electra** ELECTRA  
COMPANY

DIVISION OF MASCO CORPORATION OF INDIANA  
CUMBERLAND, INDIANA 46229

© Copyright 1979 by Electra Company

REFERENCE DOCUMENT LIST

		<u>PAGE</u>
(Fig. 1)	Block Diagram	3
(Fig. 2)	Tuning Voltage Curves	7, 8,
(Fig. 3)	FM IF (IC-2)	13
(Fig. 4)	AM IF (IC-3)	15
(Fig. 5)	Squelch Circuitry	18
(Fig. 6)	Alignment Procedure	27
(Fig. 7)	Symptom and Cure Aids	29
XD282	Schematic (Radio Board)	30
XD266	Schematic (Feature Board)	31
XD401	Parts Placement	32

BC-220 SERVICE MANUAL

SPECIFICATIONS . . . . .	1
CIRCUIT DESCRIPTION	
I.    GENERAL . . . . .	2
II.   RF AND VCO . . . . .	4
a)  VHF . . . . .	4
b)  UHF . . . . .	5
c)  VCO . . . . .	6
d)  Track Tuning . . . . .	10
III.  I.F. SYSTEM	
a)  I.F. . . . .	12
b)  AM Detector . . . . .	14
IV.   AUDIO . . . . .	16
V.    SQUELCH . . . . .	16
VI.   POWER SUPPLY . . . . .	19
VII.  SYNTHESIZER . . . . .	20
a)  Synthesizer . . . . .	20
b)  Reference Oscillator . . . . .	20
c)  Loop Filter . . . . .	20
d)  DC to DC Converter . . . . .	21
VIII. FEATURE BOARD . . . . .	22
a)  Feature Board Description . . . . .	22
b)  Keyboard and Display . . . . .	22
c)  Memory . . . . .	23
d)  Interface . . . . .	23
e)  Power Supply . . . . .	24
f)  Frequency Detector . . . . .	25
ALIGNMENT PROCEDURE . . . . .	27
SYMPTOM AND CURE AIDS . . . . .	29
PARTS LIST . . . . .	33

BC-220

TECHNICAL SPECIFICATIONS\*

Size: 10 5/8"W x 3 1/2"H x 8"D  
Weight: 5 lbs.  
Cabinet: Embossed Steel  
Power: 117 Vac, 20W; 13.8Vdc, 9W  
Antenna: Telescoping antenna (supplied)  
Connector provided for external antenna  
(50-70 ohms)  
RF Sensitivity: 0.4uV 32-50MHz  
0.4uV 144-174MHz  
0.8uV 420-512MHz  
(+5kHz deviation 12dB SINAD)  
1.0uV for 10dB S/N Aircraft 60% Mod.  
IF Selectivity: -55dB @ +25kHz  
Frequency Coverage: Low Band 32-50MHz  
Aircraft 118-136MHz  
Amateur 144-148MHz  
High Band 148-174MHz  
UHF Band 420.450-470MHz  
UHF-T Band 470.0125-512.45MHz  
Scan/Search Speed: Selectable 4 or 11 channels per second  
Audio Output: 2 Watts RMS, 8 ohms, 10% THD (max.)  
Front Panel: Volume (ON/OFF)  
Squelch (Auto. Squelch)  
Display  
Keyboard  
Speaker  
Rear Apron Connectors: 12Vdc  
External Antenna  
External Speaker Jack  
117Vac Receptacle  
Ground Terminal

\*Specifications are typical and subject to change without notice.

GENERAL

Figure 1 is a block diagram of the BC-220 receiver. From a single antenna input, the Low band (32-50MHz), Aircraft band (118-136MHz), High band (144-174MHz), and U/T (420.45-512.45MHz) frequencies are coupled through track-tuned amplifiers and mixer stages to a common IF (10.8MHz). A second oscillator at 10.4MHz is used for mixing down to a 400kHz second IF which is limited and demodulated. The recovered audio is coupled to the audio amplifier and also filtered for activation of a noise-squelch circuit.

The local oscillator is derived from a phase locked-loop synthesizer. The VCO (Voltage Controlled Oscillator) frequency is divided down by a programmable counter which is present from memory and compared to a reference frequency. Any frequency or phase difference produces a correction signal to change the VCO tuning voltage. This tuning voltage then forces the VCO to oscillate at the frequency required for the counter to produce an output that is in phase with the reference frequency. The VCO is coupled directly into the synthesizer, which eliminates other mixing, for "birdie free" operation.

The frequency program is entered from a decimal keyboard into a microprocessor where it is multiplexed to drive the display and decoded to enter the proper binary code in memory to control the synthesizer.

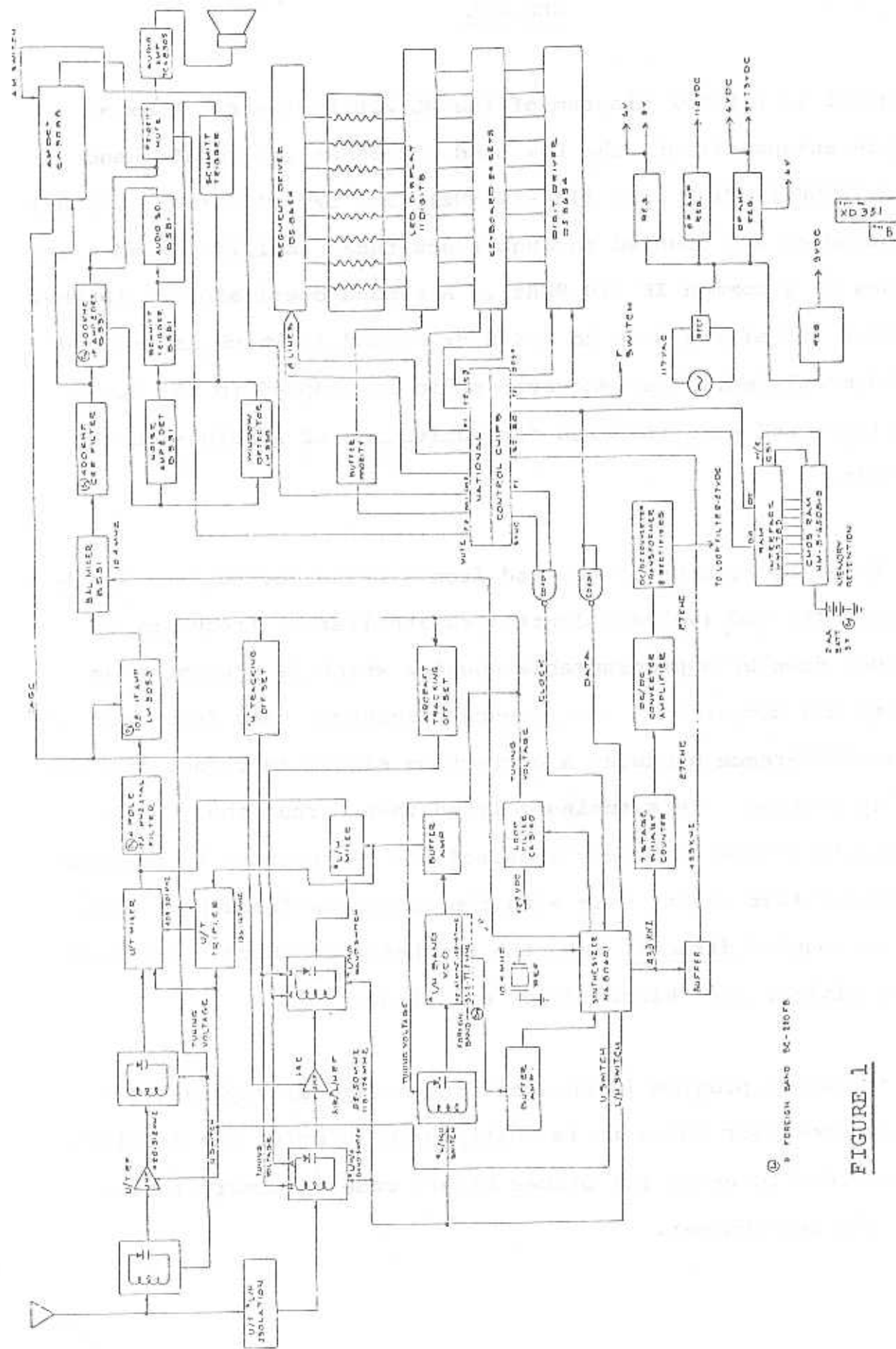

© FOREIGN BARD 80-11078

FIGURE 1

## II. RF AND VCO:

### a) VHF - L, A, and H:

An L, A, or H band signal enters the receiver through the vertical antenna or the J1 jack on the rear panel. L1 attenuates frequencies that are below the low band, while diodes D1 and D2 limit the amplitude of very strong signals that would cause an overload. C12 and L18 form a parallel resonant trap which acts as a high impedance to keep UHF frequencies from the gate of Q4. L18 is a  $1\frac{1}{2}$  turn coil which acts as a short to L, A, and H band frequencies so they pass directly to the gate of Q4. Q4 is the RF amplifier whose input and output is track-tuned. L9, L10, and VVC4 tune the input and L11, L12, and VVC5 tune the output when operating in the L band. Pin diodes D3 and D4 and capacitors C17 and C20 are used to short out L10 and L12 when operating in the A and H bands. The output of Q4 is coupled through C23 into gate 1 of the RF mixer Q5. The local oscillator for the L, A, and H bands is injected into gate 2 of Q5. The local oscillator frequency is 10.8MHz below the incoming frequency for the L and A bands. The output of the mixer Q5 is 10.8MHz. Transformer T1 is the output load for Q5 and is tuned to 10.8MHz. Q9 is used to switch the B+ off the RF amplifier Q4 during U/T band operation.

b) UHF:

The U band signal enters the receiver through the antenna input circuitry. C1 then couples these signals to the first track-tuned circuit comprised of L2, L3, VVC1, and C2. This tuned circuit acts as a pre-selector input network before the RF amplifier Q1. Q1 is in a common base configuration to improve stability and to provide better isolation between input and output. L4, on the output of Q1, provides the DC path for Q1 thus allowing the track-tuned output to operate at ground. The output track-tuned network is comprised of L5, L6, VVC2, and C8. The output is then coupled through C9 to the RF mixer Q2. Also coupling into the base of Q2 is the tripled VCO signal. The VCO signal is coupled into the base of the tripler Q3 by C14. The output is track-tuned which is comprised of L8, VVC3 and C16, then is coupled through C10 to the mixer Q2. The output of the mixer Q2, 10.8MHz, is fed to the crystal filters FL1, FL2, and T1 which is tuned to 10.8MHz to provide the proper IF frequency.

c) VCO:

The VCO circuit is a differential input voltage control oscillator which runs from 40-61MHz and 128-167MHz. Q10 is the actual oscillator and Q11 is used primarily as a buffer.



c) VCO: (Continued)

The frequency determining components are L14, L15, VVC6, VVC7, C30, and C31. Feedback is provided for the oscillator through C25 (A, H, & U/T bands) and C32 (L band).

During L band operation both coils L14 and L15 are in circuit with VVC6 and VVC7, but L14 and VVC6 are both so small in value at L band frequencies that L15 and VVC7 are the most significant components. Then during A, H, & U/T bands, D8 is turned on through R42 which A.C. grounds the bottom of L14 through C33. This shorts out L15 and VVC7 making L14 and VVC6 the most significant components.

The output of Q11 is fed to the base of Q13 and Q14. These two transistors operate as emitter followers (buffers) to isolate the outputs from the VCO. Q14 is used to isolate the synthesizer from the VCO by coupling through C37 into Pin 17 of IC-8. Q13 is used to couple the VCO signal to Q12 through C34. Q12 is a buffer amplifier whose output coil L13 is tuned for the A band. This output of Q12 is then coupled through C29 to the gate input of Q5, the L, A, and H band RF mixer, and is coupled through C14 to the base of the U/T tripler. Tuning voltage vs. frequency - Refer to Figures 2-A, 2-B, and 2-C.

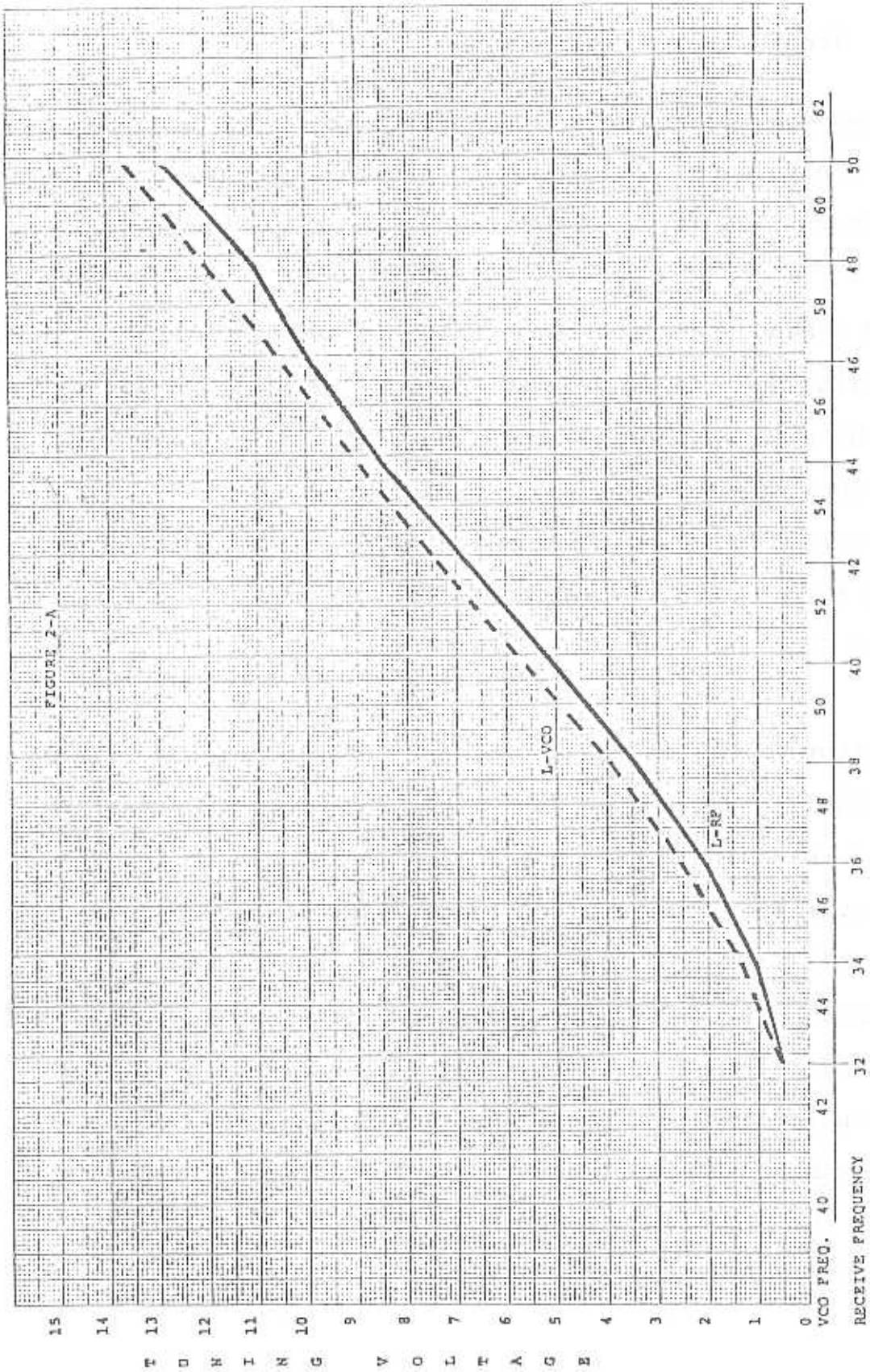

FIGURE 2-A

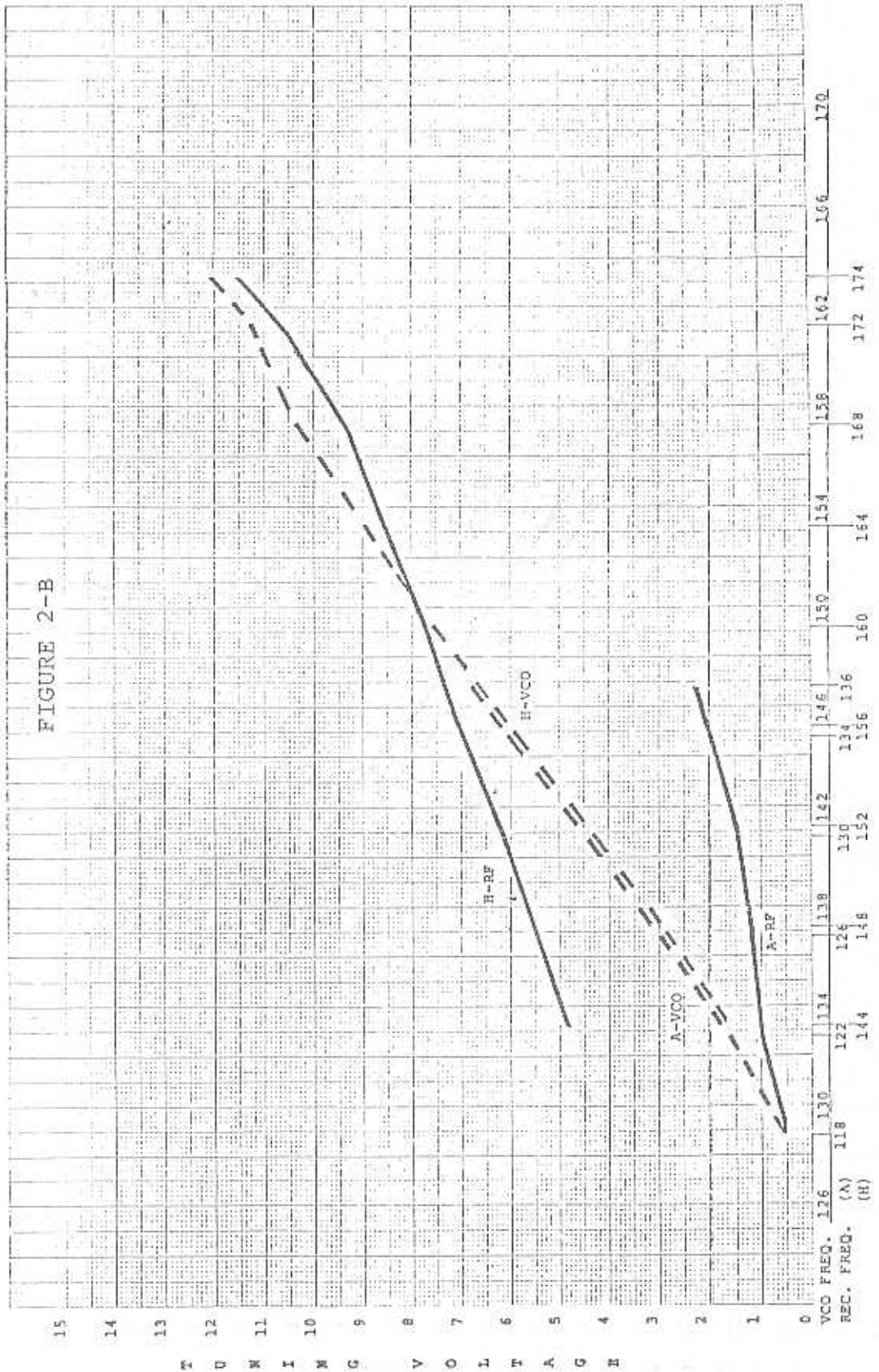

FIGURE 2-B

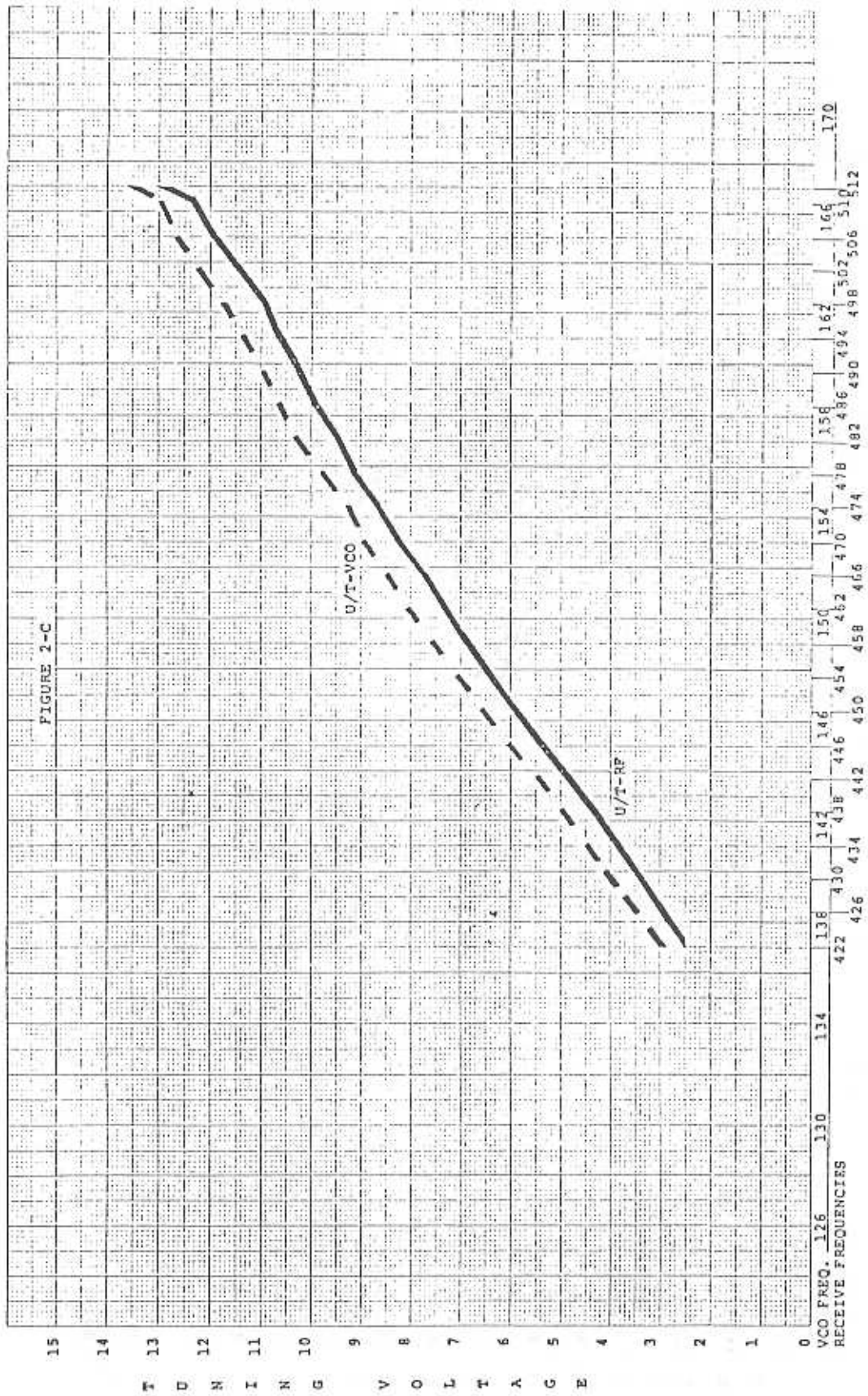

FIGURE 2-C

d) Track Tuning - Offset:

Track-tuning is the function of the tuning voltage vs. frequency. The L and U/T band RF circuits are tuned directly from the tuning voltage along with the VCO. The H band RF circuits have a 3 volt step at the low end and the A band RF circuits are gradually raised at the high end to provide proper tuning. Q6, Q7, Q8, D5, and D6 provide the switching and offsets needed.

There are 3 inputs to the offset circuits. They are: Pins 13 and 14 of IC-8 and Pin 3 of IC-3. During L band, all three inputs are low. With Pin 3 of IC-3 being low, D5 is turned on holding Q8 off. Also, Q7 is off which turns Q6 on and reverse biases D6 so in the L band the tuning voltage is coupled straight through R38 to the RF section.

During A band, Pin 3 of IC-3 goes high which reverse biases D5 and allows Q8 to now function. Pin 13 of IC-8 is still low and Pin 14 of IC-8 goes high which turns on Q7 and with the emitter high, this allows the collector to be high also turning on Q6 and reverse biasing D6. This allows Q8 to do the controlling of the tuning voltage by the use of R35, R36, and R37. At 118MHz, the low end of the A band, the tuning voltage is too low to turn on Q8, but as the frequency increases, the tuning voltage increases which turns on Q8 and flattens out the tuning curve for proper tuning.

d) Track Tuning - Offset: (Continued)

During H band operation, Pin 3 of IC-3 is low which turns D5 on and holds Q8 off. Pin 13 of IC-8 is low while Pin 14 of IC-8 goes high turning Q7 on. When Q7 turns on, Q6 is turned off giving the tuning voltage a 3 volt step at the low end through D6 and R25.

During U/T band operation, Pin 3 of IC-3 goes low while Pins 13 and 14 of IC-8 are high. Q6 and Q7 are both turned on which reverse biases D6 and turns on D5 disabling Q8. This allows the tuning voltage to be coupled directly through R38.

In summary, the L and U/T bands are tracked directly with the VCO; a 3 volt step is added at the low end of the H band and the high end of the A band is flattened out for proper tuning.

Band Switching Control Lines	L	A	H	U/T
IC-3/Pin 3	0	1	0	0
IC-8/Pin 13	0	0	0	1
IC-8/Pin 14	0	1	1	1

### III. IF SYSTEM:

#### a) IF:

The outputs of the L, A, and H band mixer Q5 are fed into the primary of T1, which steps the output down to a level comparable to the output level from the U/T mixer Q2. T1's output is coupled into a 10.8MHz four-pole crystal filter (which filters out all frequencies except 10.8MHz) through R52. R52 is used to match the impedance of the filters with transformer T1. The IF frequency, which is 10.8MHz, is then coupled into the input of IC-1, the first IF amplifier. L17 is used to resonate with the internal capacity of IC-1 at 10.8MHz to provide a match for the output of the crystal filters. Diode D9 provides a constant 1.7V drop from the AGC voltage line to provide proper gain adjustment for the Aircraft band. During FM operation, the voltage supplied to D9 is held high for maximum gain. Transformer T2, which is resonant at 10.8MHz, will provide the output tuning of the differential pair used in IC-1. IC-1 provides about 16dB of additional IF gain to insure sufficient noise limiting in the receiver. The output of IC-1 is coupled through capacitor C60 into Pin 16 into IC-2. Referring to Figure 3, a 10.4MHz frequency is coupled into Pin 1 of IC-2 to provide mixing down to the second IF, 400kHz. The 400kHz second IF is available at Pin 3 and is coupled into a ceramic filter, CF3, to provide additional selectivity. The output of the

FM IF RECEIVER AND SQUELCH SUBSYSTEM -IC-2

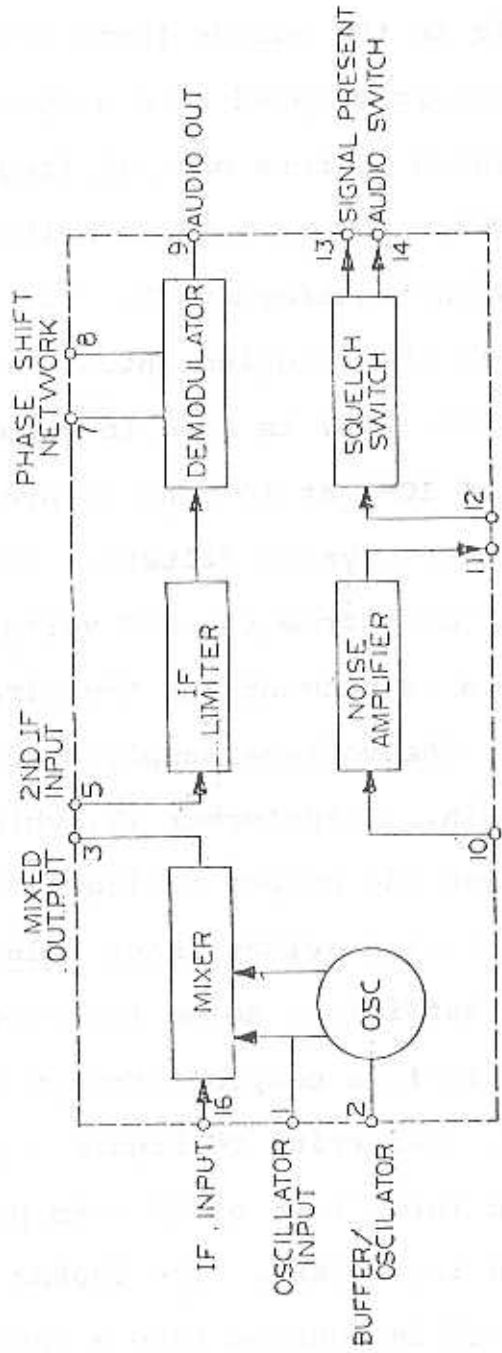

FIGURE 3



a) IF: (Continued)

ceramic filter is coupled to Pin 5 of the internal IF amplifier. The signal is then limited and demodulated with the recovered audio output at Pin 9. Transformer T3, capacitor C51, and R61 provide the phase shift to balance the demodulator.

b) AM Detector: (Refer to Figure 4)

The output of the ceramic filter, CF3, is coupled through capacitor C59 to Pin 4 of IC-3 which is the AM sub-system. The first IF amplifier provides an output on Pin 6 which is connected to transformer T4 and tuned to 400kHz. The secondary of T4 is connected into the input of the second IF amplifier. The AM sub-system also features a detector with an audio output available at Pin 9. The detected output is fed through R68 and to an RC combination of C55 and R67 which rolls off some of the high frequency components at about 3kHz. The output of the network is coupled through R66 to the audio input Pin 14. R64 is a feed-back resistor for an operational amplifier (used as a pre-amplifier) between Pins 14 and 15 of IC-3. This provides a gain of approximately 4 for the audio signal. The audio output off of Pin 15 is then coupled through C69 to the volume control. An AGC signal (DC voltage) inversely proportional to the input signal is provided at Pin 13 to control the gain of IC-1, Q4, and IC-3

AM RECEIVER SUBSYSTEM - IC-3

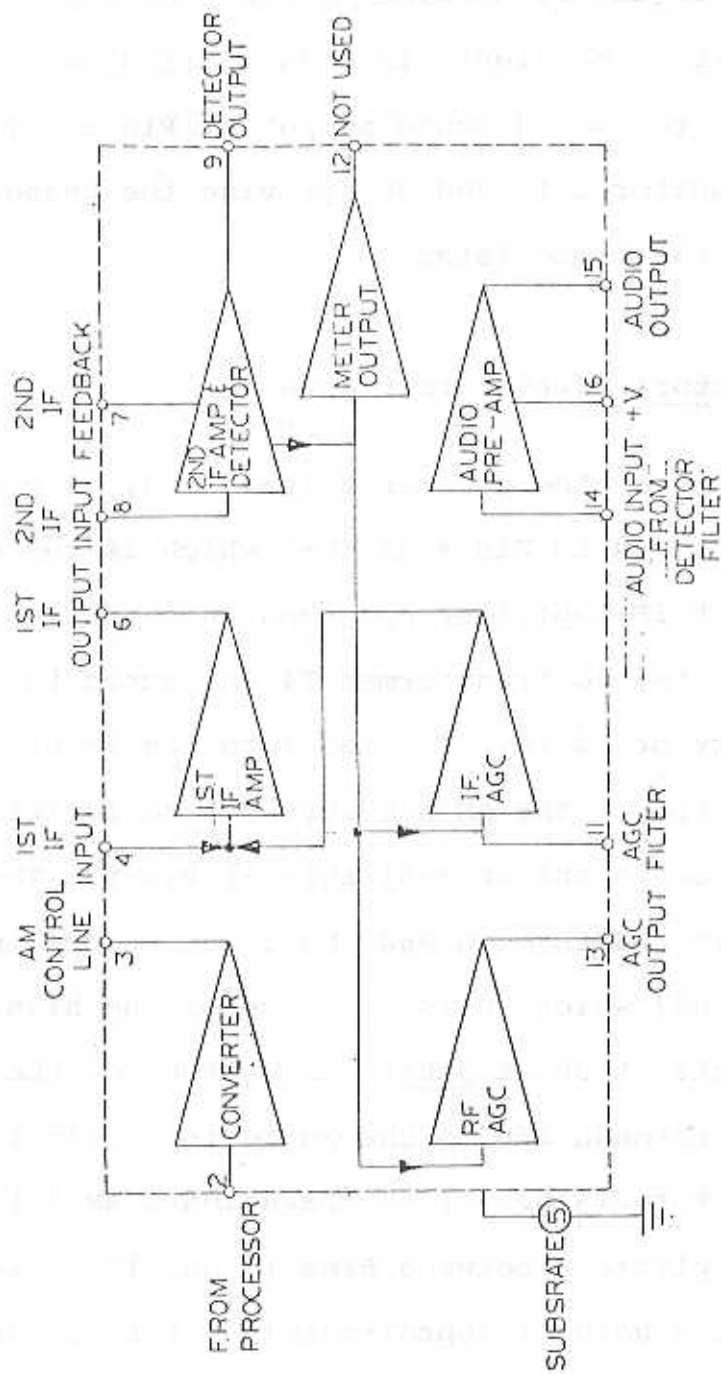

FIGURE 4

b) AM Detector: (Continued)

to prevent an overload condition. During all FM modes, Pin 13 is at 2.5 volts to provide maximum gain.

IV. AUDIO:

The audio from the wiper of the volume control R94 is fed into two RC low-pass filter networks: R95, R97, C70, and C71 which attenuates frequencies above 3500 Hz. At the volume control is an NPN transistor Q16 which is used for the mute function to mute the audio during synthesizer transitions and priority sample. After this low-pass filter, the audio is coupled into Pin 8 of IC-4, the audio amplifier, which provides amplification to drive the speaker. The function of the external components is as follows: R92 sets the closed loop gain of the amplifier. R91 and C73 reduce saturation losses during positive half-waves. C76 sets the upper cutoff frequency. C75, C78, and R93 increase frequency stability and prevent oscillations. C79 filters ripple on the power supply line.

V. SQUELCH: (See Figure 5)

The noise squelch system uses an operational amplifier within IC-2 as a bandpass amplifier. The resonant frequency 8kHz, Q, and gain are determined by external components C64, C65,

V. SQUELCH: (Continued)

C66, R87, R88, and R90. It is necessary to shape the noise power pass-band so that normal audio frequencies do not activate the squelch system. When no transmission is being received, the high frequency noise 8kHz is amplified by IC-2. The noise is then coupled through C63 and detected by D10 to produce a negative voltage which is filtered by C40, C62, and R85. Two back-to-back capacitors are used because the voltage swings both positive and negative. The detected negative voltage is then applied through R84 to Pin 12 of IC-2 which overcomes the positive bias provided from the squelch control R79, through R212 and R213 connected to Pins 1 and 7, respectively of IC-205, the window detector on the feature board. With the voltage at Pin 12 of IC-2 below the turn-on level due to the negative voltage from the detected noise, Pin 13 voltage will go high to permit the receiver to scan. Pin 14 will go low shutting off the audio at the volume control R94. When a signal is received, the resultant signal in the IF produces noise quieting by limiting through the system which reduces the 8kHz noise; thereby reducing the negative voltage level from the detected noise. This reduced negative level permits the positive bias of R79 to reach a turn-on level at Pin 12 of IC-2 which causes Pin 13 to go low to stop scanning and shuts off the Pin 14 output to enable the audio to reach IC-4 for amplification. Q15

BC-220 SQUELCH SYSTEM

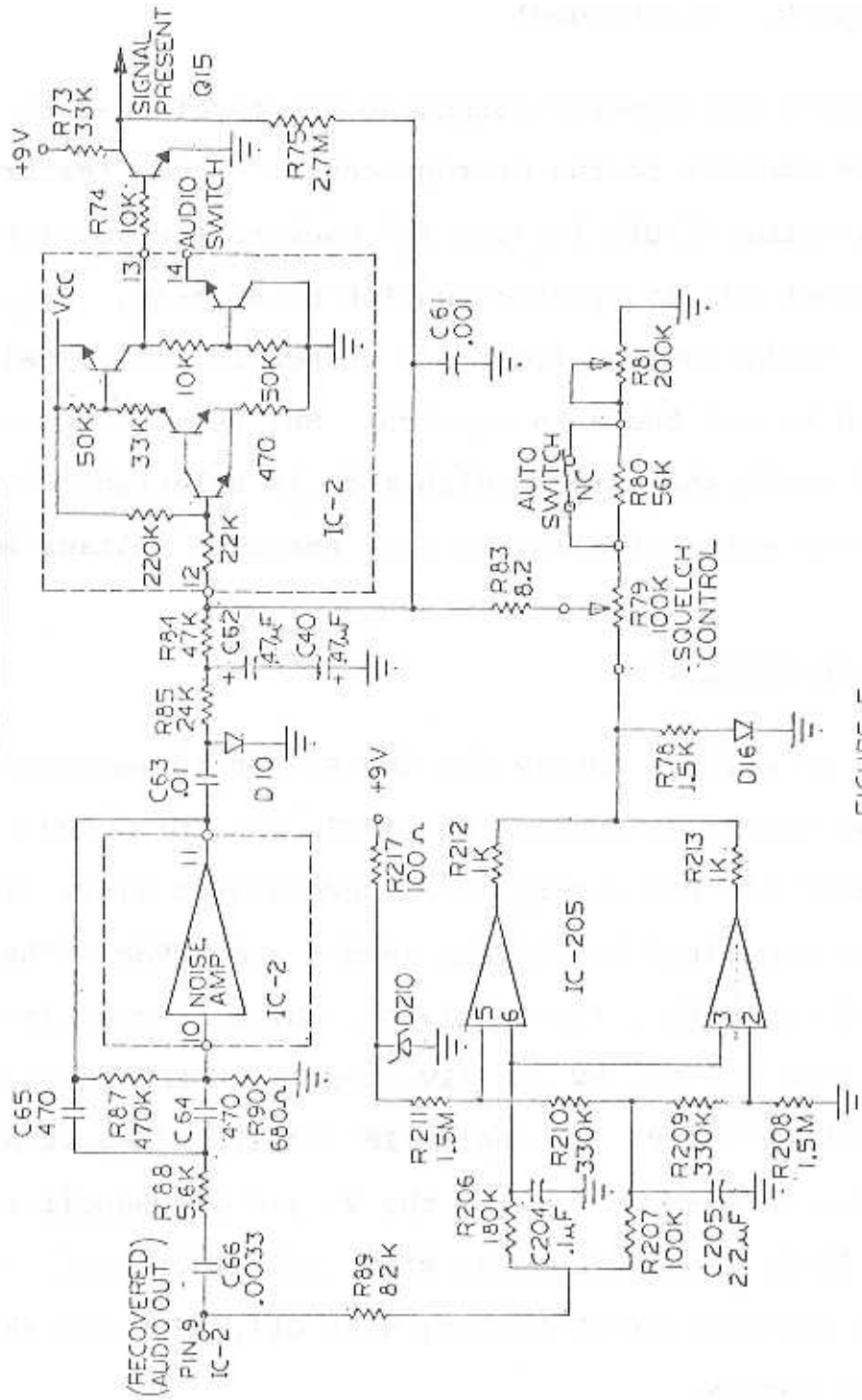

FIGURE 5

V. SQUELCH: (Continued)

inverts the squelch output at Pin 13 of IC-2 to provide the scan control to the microprocessor on the feature board. The collector of Q15 is also fed back to the squelch input (Pin 12) through R75 to provide squelch hysteresis. R81 is used to set the tight squelch limit for proper lock-in. SW1 and R80 are used to set the auto squelch. SW1 is normally closed shorting R80 until the auto squelch mode is selected. Then R80 is in series with R81 allowing more positive voltage at Pin 12 of IC-2.

VI. POWER SUPPLY:

The DC voltage supply for the BC-220 is developed by a full wave rectifier consisting of T5, D14, D15, and C101. The DC output of this supply is an unregulated +16V. This 16Vdc is then regulated to +11Vdc, +9Vdc, and +5Vdc. The 5V is developed by IC-6, a +5V regulator, which is used as the reference voltage for the 9V and 11V along with the supply for the synthesizer (IC-8) and the FM IF (IC-2). IC-5 is a dual op-amp which is used to develop the 9V and 11V supplies. One-half of IC-5, along with Q18, R101, and R102 develop the +9V supply and one-half of IC-5 along with Q17, R98, and R99 develop the +11V supply.

## VII. SYNTHESIZER:

### a) Synthesizer:

The synthesizer (IC-8) is a custom integrated circuit which contains the reference oscillator, counter, divider, band-switching and phase detector functions. The input frequency response is good up to 175MHz thus requiring no other mixing. Direct synthesis in this case provides "birdie free" operation of the scanner radio.

### b) Reference Oscillator:

The reference oscillator is contained within IC-8; however, external components govern the frequency. The 10.4MHz crystal Y1 is the frequency controlling component and C83 and C84 provide the feedback for this modified Colpitts oscillator. C82 is used to set the oscillator on frequency which is then coupled through C80 to the IF system (IC-2) for dual conversion mixing down to 400kHz. The reference oscillator is also fed internally to a divide chain whose output is used as the reference frequency for the phase comparator.

### c) Loop Filter:

The loop filter is an integrator that takes the correction pulses from the phase comparator and converts them to a DC

level. R109 and R110 in conjunction with the filter capacitor C91, sets the bias voltage on Pin 3 of IC-7. C88 and R107 filter the input of IC-7 Pin 2 from the phase comparator output. D21 is used to speed the loops lock-up time when scanning. C90, through R108, charges to oppose the input changes and holds the output at a DC level.

If the VCO is running too low in frequency, negative correction pulses will go to the inverting input forcing the output voltage to go higher. In the same manner, when the VCO is too high in frequency, positive correction pulses from the comparator will cause a decrease in DC voltage until the VCO is on frequency. When the VCO is on frequency, the charge on C90 will hold this DC voltage, keeping the VCO on frequency while the phase comparator goes to a high impedance state.

Since the width of the correction pulses is dependent on a degree of phase difference, the further the VCO is off frequency, the wider the pulse will be. The output of IC-7 is a varying DC voltage from approximately 0.5Vdc to 16Vdc which is used to tune both the VCO and RF amplifiers through their offsets.

d) Synthesizer Generated DC to DC Converter:

The 10.4MHz reference oscillator is internally divided in



d) Synthesizer Generated DC to DC Converter: (Continued)

IC-8 to provide a 433kHz signal on Pin 1. The signal is coupled through R111 into Pin 1 of IC-9. IC-9 is a 7-bit divider and is used to divide 433kHz by 16. The output of the divider is a 27kHz square-wave from Pin 6. This square-wave is coupled through C93 and formed into a triangular wave using R114 and C94. This signal is fed into Pin 8 of IC-10 which is an audio amplifier used to amplify the incoming triangular waveform. The output of IC-10 on Pin 5 is coupled through C98 to the primary of T6. T6 steps up the voltage to a suitable level to be rectified by diodes D18 and D19 and filtered by capacitor C106 to provide a positive +25V DC for the loop filter supply IC-7.

VIII. FEATURE BOARD:

a) Feature Board Description:

IC-203 and IC-204 is a custom programmed microprocessor pair which accepts a decimal keyboard input converted to our appropriate binary code for synthesizer control. They also enter the data into channel memory and multiplex information for the 11-digit, 7-segment display.

b) Keyboard and Display:

A decimal keyboard is used to control data inputs K1, K2,

and K3 of the microprocessor which decodes the timing pulses from the digit driver outputs of IC-207. Display data is multiplexed to supply source voltage to each required segment during the sequential strobing of the digit cathodes to display the information. IC-206 is an 8-section display driver to supply current for each segment through its' associated 100 ohm resistor.

c) Memory:

IC-202 is a CMOS 1k x 1 RAM. This RAM is serviced through the RAM interface IC-201. The interface accepts serial data from the microprocessor, converts it to parallel information to address the memory and loads the memory. The interface in the READ mode accepts the serial data from the RAM; converts it into the proper coding and processes it back into the microprocessor in serial format.

d) Interface:

IC-208 is a quad "nand gate" and is used primarily to invert the data for the synthesizer; also to provide the enable for the synthesizer clock. Q202 is used as a "nand gate" from both chip selects for the chip enable function on Pin 1 of IC-202. Q203 is used as an amplifier to amplify the system clock for the microprocessor. Q204 is a Darlington transistor to enable the cathode of the 5 segments for the "P"

d) Interface: (Continued)

(priority) in the display since it is not multiplexed. Q205 is a switch that enables the synthesizer IC-8 to operate using foreign band frequencies (66-88MHz). Q206 is utilized as an active power-on reset through the use of C207 and R234 time constant. In normal operation, Q206 will be off. As the 9V power supply comes up initially, C207 is discharged which causes Q206 to conduct, holding Pin 2 at ground as C207 charges to 9V. Q206 turns off immediately switching Pin 2 to 9V. This step function then sets the program counter to zero thus initializing the microprocessor to the first instruction. D207 and D208 are called strap diodes and are used to alter the processor to a prescribed condition. D207, when installed, changes the IF frequency from 10.8MHz to 10.85MHz. D208, when installed, changes the L band to F band (foreign) along with the other foreign band changes indicated by the \*.

e) Power Supply:

The Feature Board power supply has two main supplies; +9V and +5V. The 9V is developed from the switched +16V, Q201 (pass transistor), D204, and R201. D204 sets up the bias for Q201 through R201. Then the +5V is developed from the 9V, feeding into IC-209, a 5V regulator. D201 and D202 are used to keep the +5V across the interface and memory at the same potential.

e) Power Supply: (Continued)

D202, D203, and D213 are used as an "OR" gate. VA, which is the memory supply, gets its voltage from either the +5V, the battery, or the memory keep-alive supply D212 and R238. The memory keep-alive supply keeps power to the memory when the radio is turned off and not unplugged.

f) Frequency Detector Squelch: (Window Detector)

The purpose of this circuit is to keep adjacent channel activity from unsquelching the radio. This would happen in conventional scanner radios in the presence of strong or interfering signals. This signal will not let the radio unsquelch if the signal is more than 7kHz from the received frequency. The voltage comparator window detector is IC-205, dual operational amplifier LM 358. The upper voltage limit is on Pin 2. These voltages are established by R208, R209, R210, and R211.

If the voltage above the upper limit or below the lower limit appears on common Pins 3 and 6, the output of Pin 1 or 7 will go low. This reduces the voltage of Pin 12 of IC-2 forcing the receiver to continue scanning. If the voltage is within the limits or within the window, both outputs will be high. With both outputs in normal operation, the squelch control R79 is used to set the bias of Pin 12 of IC-2. If

f) Frequency Detector Squelch: (Window Detector)

these outputs are high, and other squelch conditions acceptable, the radio will be unsquelched. The discriminator output (IC-2 Pin 9) develops a DC voltage which is inversely proportional to frequency. The slope of the discriminator is approximately .18V per kilohertz from the center frequency and has a DC offset of 2.75V. This voltage is filtered by R89 and C67 and serves as a window detector input.

BC-220 ALIGNMENT PROCEDURE

NO. DESCRIPTION	INPUT SIGNAL	ADJUSTMENT	NOTES
1) H Band - Tuning Voltage Calib.	None Radio programmed to 146.05	Adjust L14 for 2.4V ±.05V at TP1	
2) L Band - Tuning Voltage Calib.	None Radio programmed to 33.76MHz	Adjust L15 for 1.2V ±.05V at TP1	
3) I.F. Adjustment	<p>Method 1: Apply a swept 10.8MHz signal to antenna input. It is desirable to sweep +25kHz at a 60Hz rate (or less). See notes for level. (Radio may be programmed to all L or H frequency).</p> <p>-----</p> <p>Method 2: Apply an L or H signal swept by a sawtooth waveform +25kHz. Program radio to L or H signal generator frequency.</p>	<p>Monitor output of TP2 with detector probe. Scope should be set to .01 to .05V/Div. range. Adjust scope pattern T1 maximum amplitude T2 for minimum ripple.</p> <p>Adjustment same as Method 1.</p>	<p>It is important that the signal input level be adjusted to keep I.F. from limiting. If sweep is at 60Hz rate, scope may be on line sync, otherwise horizontal input must be attached to sweep signal.</p>
4) Frequency Adjustment	None	Connect a frequency counter to TP3 (R11) 10.40000MHz.	Any frequency may be used. *Couple TP3 through a .01uF capacitor to counter.

BC-220 ALIGNMENT PROCEDURE

NO. DESCRIPTION	INPUT SIGNAL	ADJUSTMENT	NOTES
5) Discriminator Adjustment	Program radio to 465.3MHz 1.0kHz Mod. 3.3kHz Dev. 5-10uV	Adjust T3 for maximum audio.	Connect an AC VTVM to audio output jack.
6) L Band Alignment	Program radio to 33.76MHz. Apply a 33.76MHz signal @1uV to the antenna input. No modulation.	Adjust L10 & L12 for best quieting at audio output.	It may be necessary to reduce signal level and re-adjust L10 & L12.
7) H Band Alignment	Program radio to 146.05MHz. Apply a 146.05MHz signal @1uV to antenna input. No modulation.	Adjust L9 & L11 for best quieting at audio output.	It may be necessary to reduce signal level and re-adjust L9 & L11.
8) U/T Band Alignment	Program radio to 420.825MHz. Apply a 420.825MHz signal @2uV to antenna input. No modulation.	Adjust C2, C8, & C16 for best quieting at audio output.	It may be necessary to reduce signal level below 2uV to the point where the effect of adjustment can be measured.
9) AM I.F. Adjustment	Program radio to 118.8MHz. Apply a 1.0uV signal @ 118.8MHz 60% modulation, to the antenna input.	Adjust T4 for maximum audio.	Connect an AC VTVM to the audio output jack.
10) Tight Squelch Adjustment	Program radio to 511.912MHz. Apply a 2.0uV signal @ 511.912MHz to the antenna input.	Adjust R81 until the radio locks on signal.	Rotate <u>squelch control CCW</u> , <u>but not in Auto</u> and <u>push Scan</u> .

BC-220 SYMPTOM & CURE AIDS

SYMPTOM

COMPONENT

- 1) No or weak receive on L Band 10.4MHz off frequency, Q4, Q5, band switching, IC-1, IC-2
- 2) No or weak receive on A Band 10.4MHz off frequency, Q4, Q5, band switching, IC-1, IC-3
- 3) No or weak receive on H Band 10.4MHz off frequency, Q4, Q5, band switching, IC-1, IC-2
- 4) No or weak receive on U/T Band Q1, Q2, Q3, (C2, C8, C16) shorted, band switching
- 5) No or weak I.F. IC-1, IC-2, CF1, CF2, CF3, T1, T2
- 6) No squelch or won't unsquelch IC-205, IC-2, D10, Q15, misaligned R81
- 7) No audio IC-4, Open J2, Q16 (shorted)
- 8) Power Supply T5, IC-5, IC-6, Q17, Q18, Q201, D204, IC-209
- 9) Won't program IC-201, IC-202, IC-203, IC-204, IC-208
- 10) Won't hold program IC-201, IC-202, IC-203
- 11) Missing segments IC-203, IC-206, R223-R230, Display
- 12) Missing digit IC-203, IC-207, Display
- 13) No display or dot Y1, Power Supply, Q203, Q206, IC-203, IC-204, IC-8



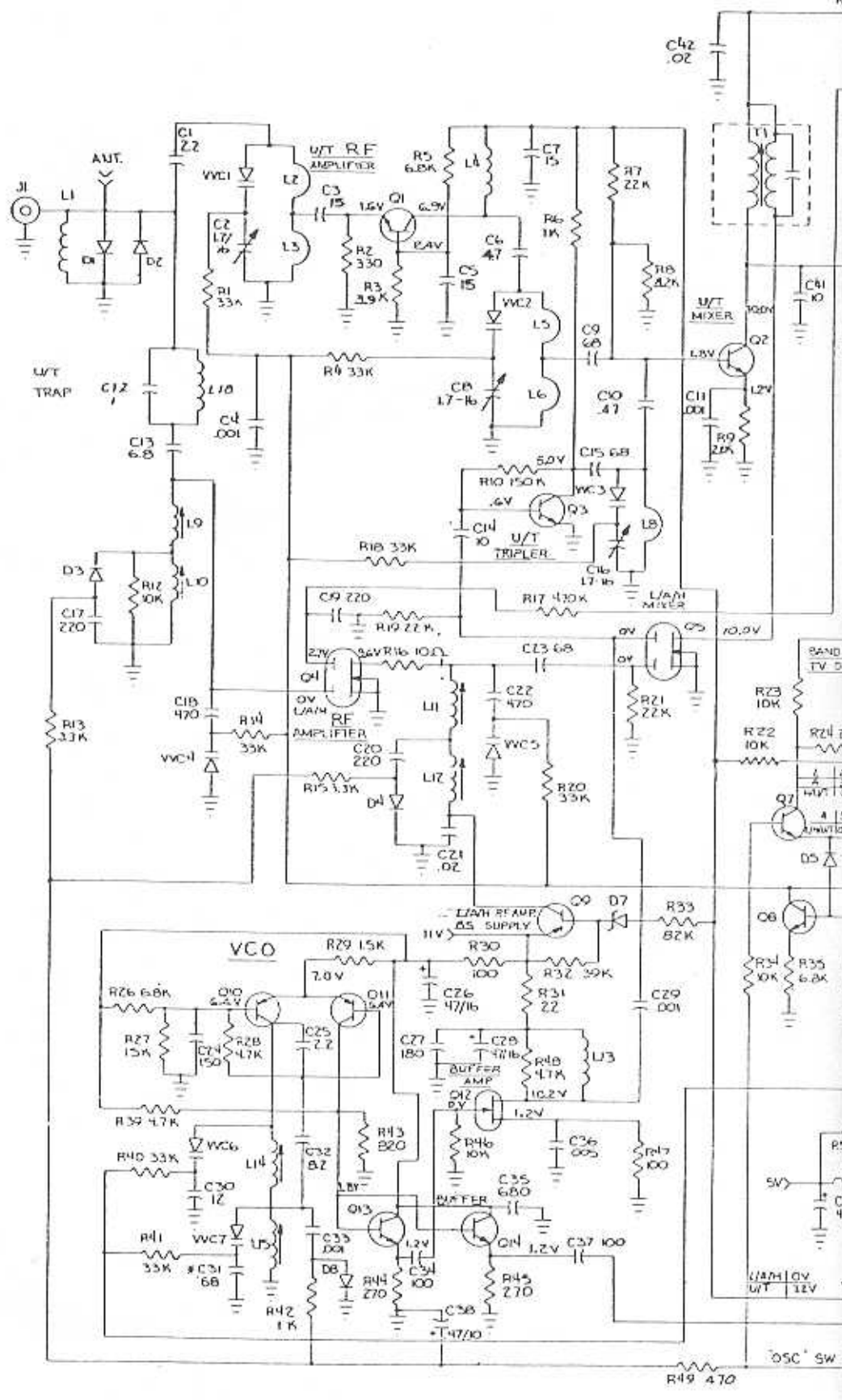

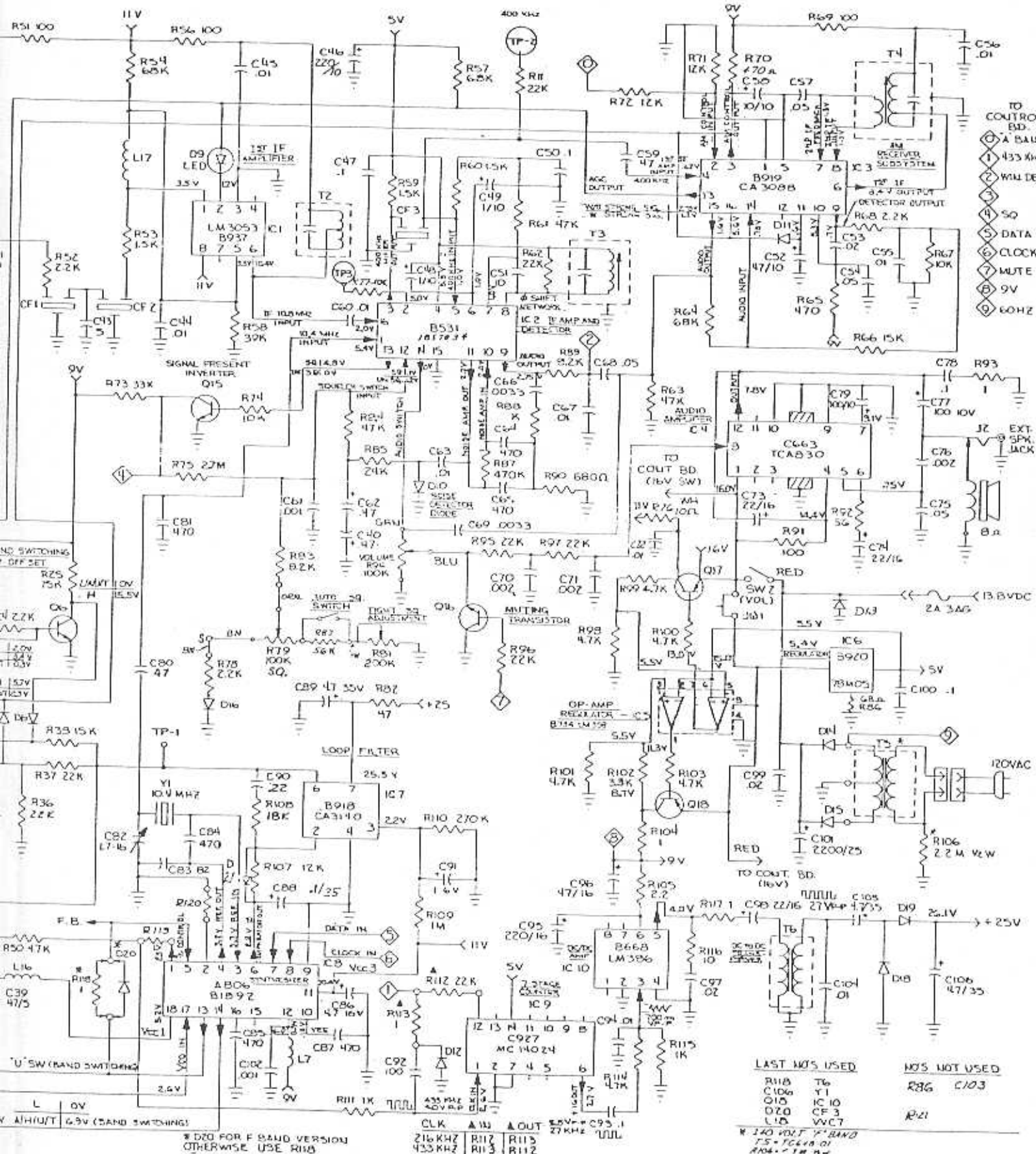

- TO CONTROL BOARD:
- 1 433 KHZ
  - 2 WML DET
  - 3 50
  - 4 DATA
  - 5 CLOCK
  - 6 MUTE
  - 7 9V
  - 8 60HZ

LAST NOS USED	NOS NOT USED
R18	T6
C106	Y1
C10	IC10
D20	CF3
L10	WCT

\* 140 VOLT 1/2 BAND  
 15-164A 01  
 100-17 1M H  
 C31-150

\* D20 FOR F SAUD VERSION  
 OTHERWISE USE R18

CLK IN OUT  
 216 KHZ R117 R115  
 433 KHZ R113 R112

5V- C95.1  
 27KHZ WML

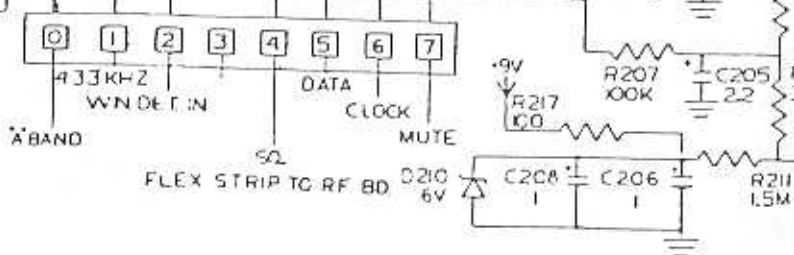
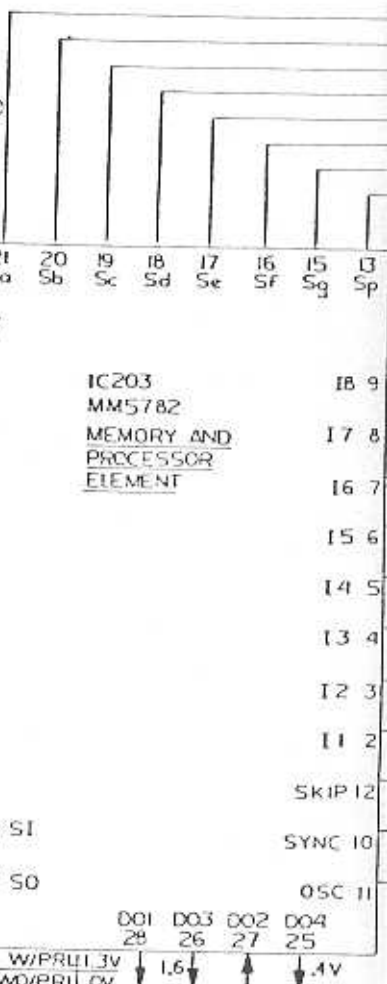
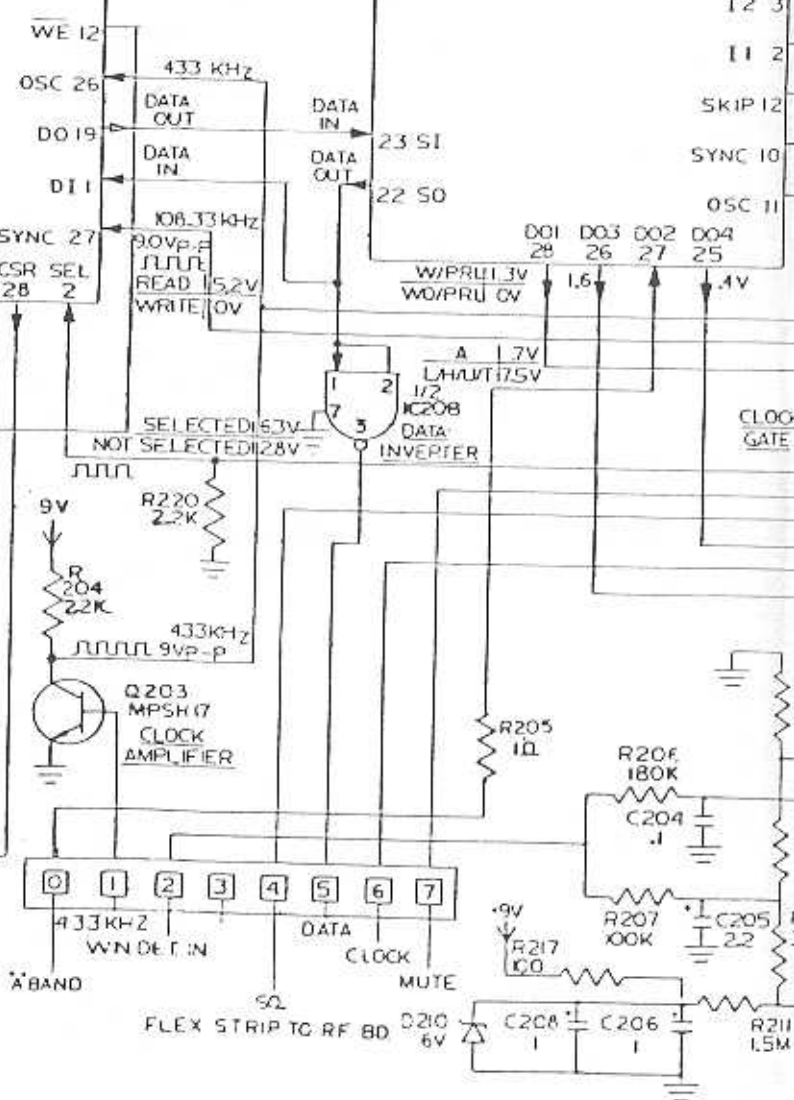
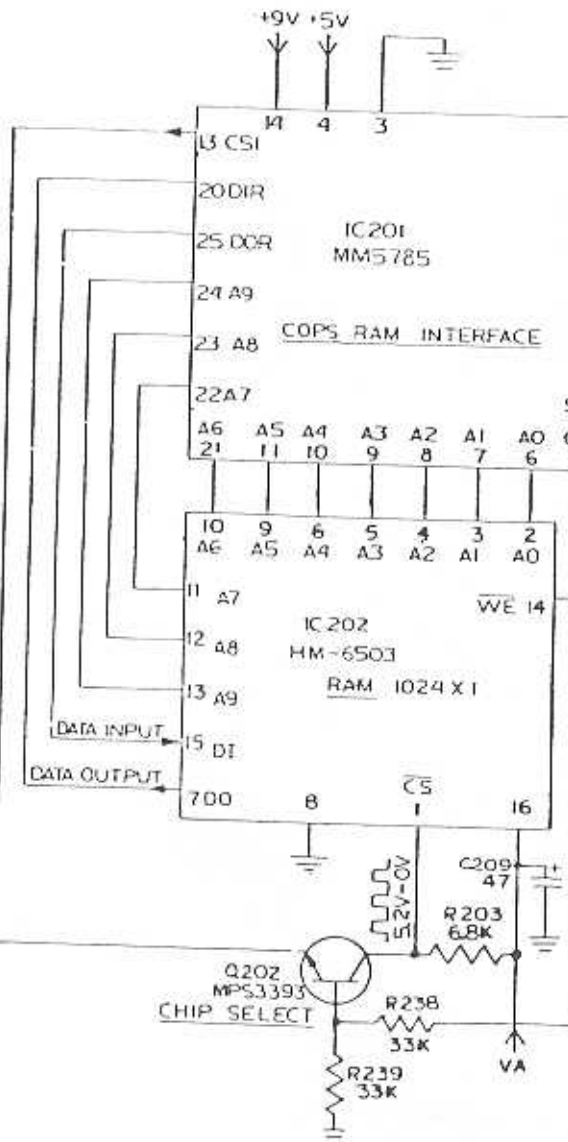
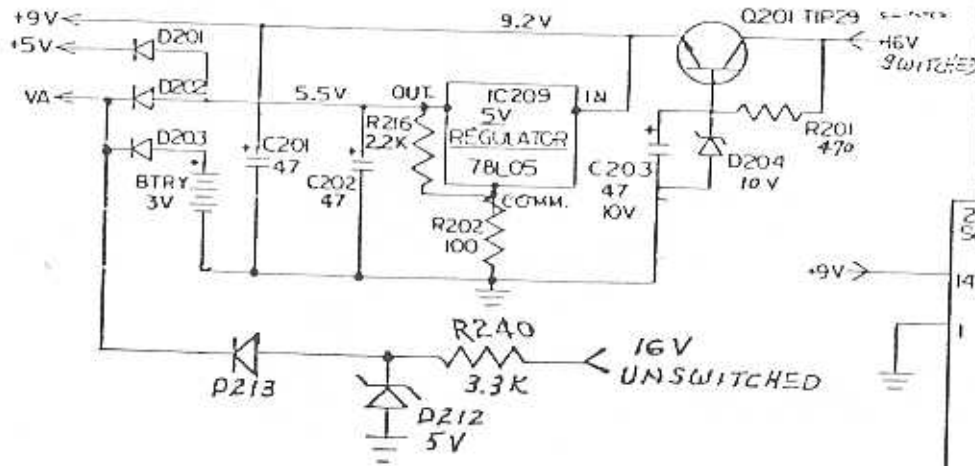
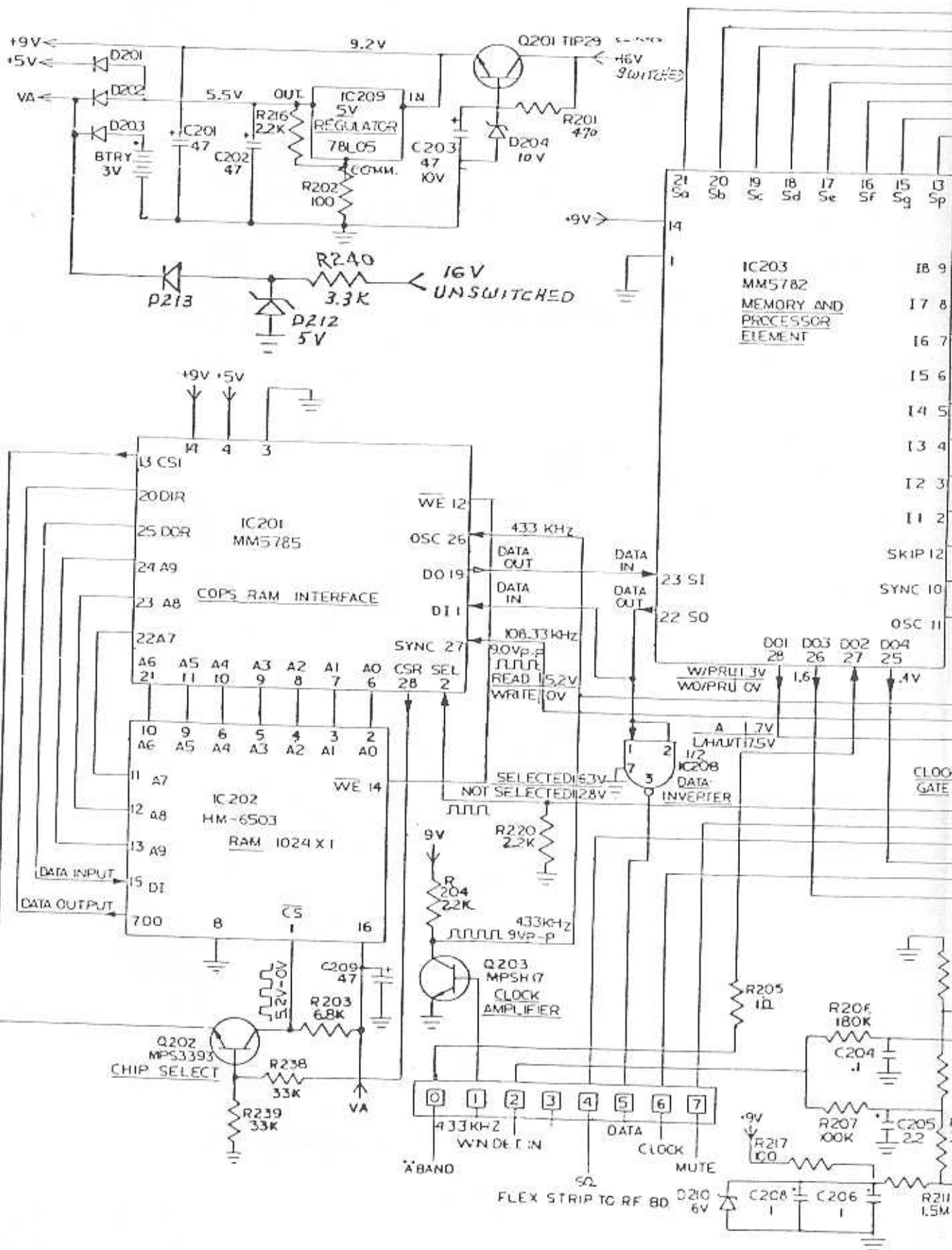

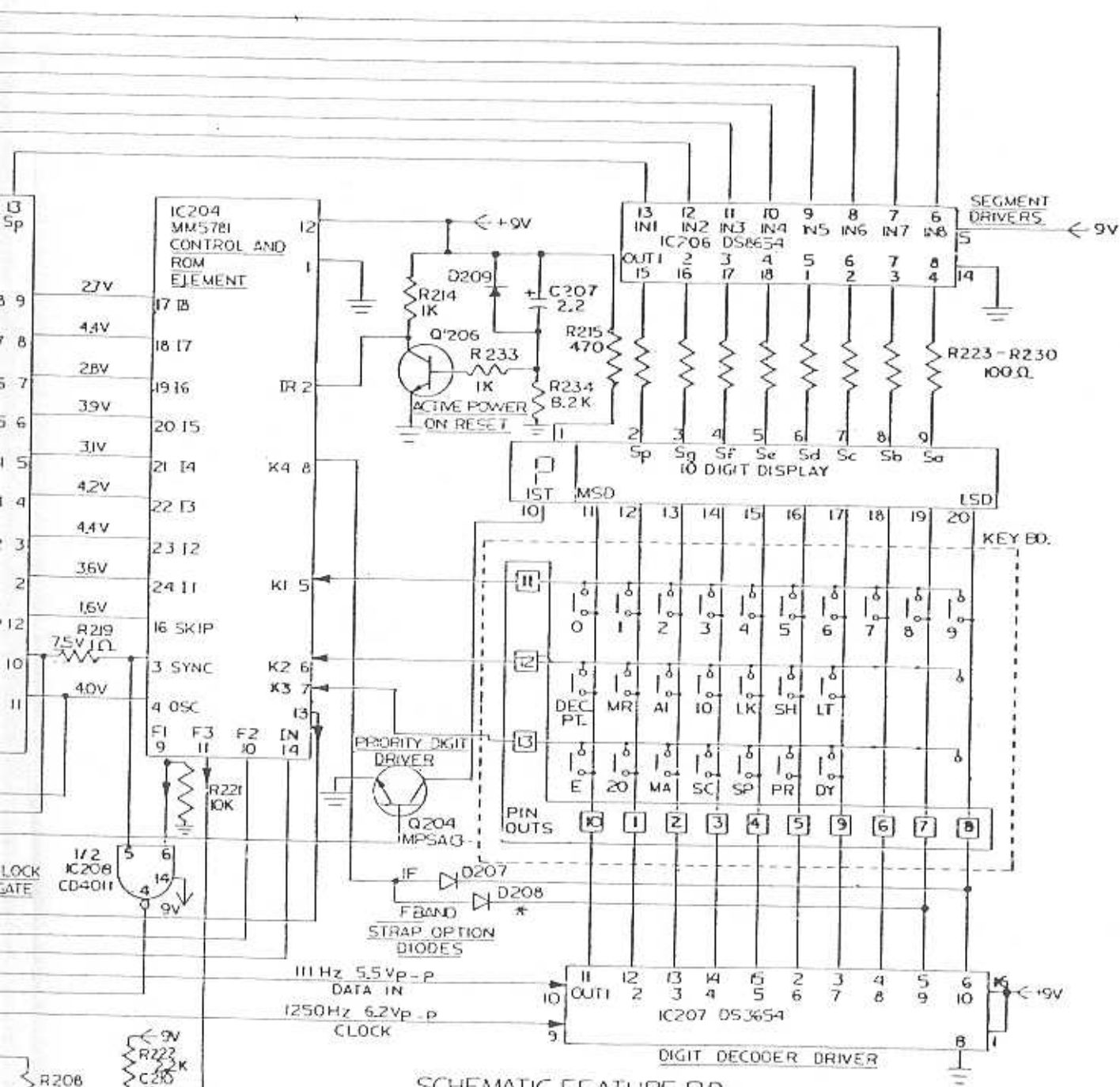

**SCHEMATIC FEATURE BD**

ALL RESISTOR VALUES IN OHMS  
ALL CAPACITOR VALUES IN MICROFARADS  
LAST INDICATOR USED:

- |                     |       |          |
|---------------------|-------|----------|
| CAPACITORS          | C210  | NOT USED |
| DIODES              | D208  | D205     |
| INTEGRATED CIRCUITS | IC208 | R218     |
| RESISTORS           | R210  | R235     |
| TRANSISTORS         | Q208  | R236     |

\* USE WITH "F" BAND, 210 i  
D208  
D211  
R231  
R232  
Q205  
W18

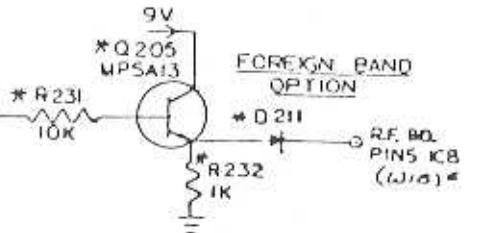
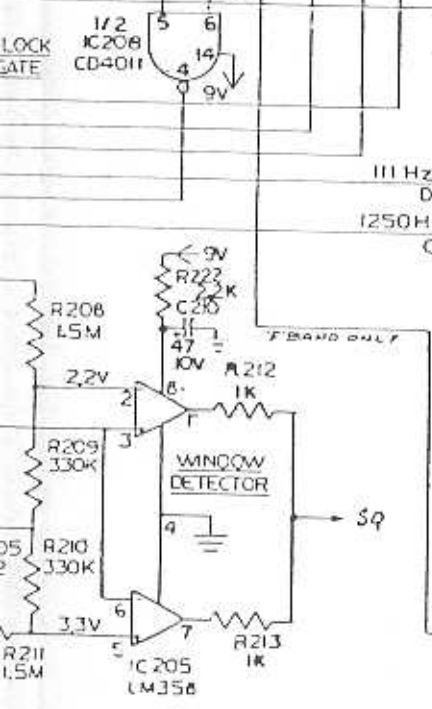

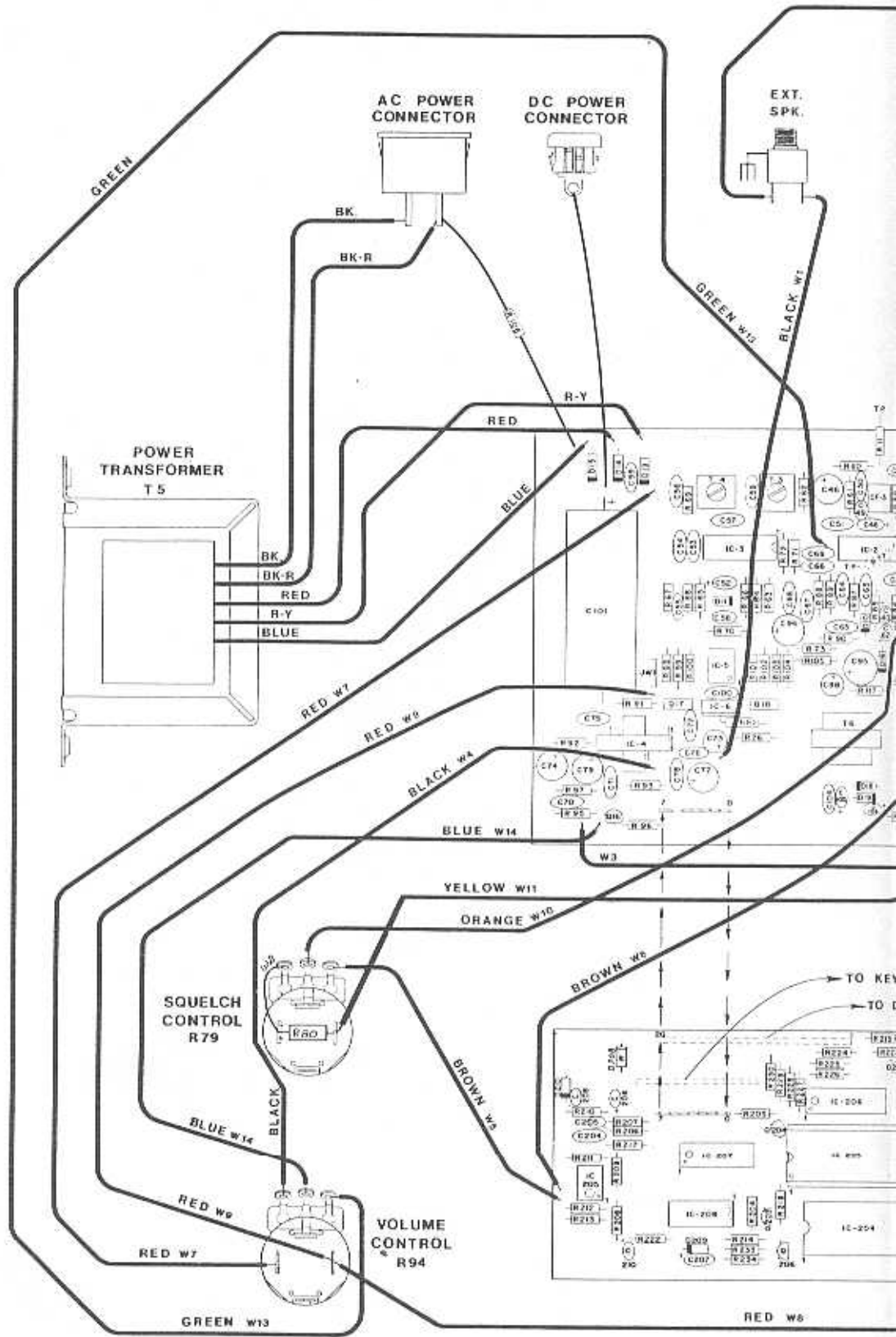

**FEATURE BOARD**

LAST NO. USED

- R239
- C210
- D211
- Q206
- IC-209

NO'S. NOT USED

- R218
- R237 R235 R236
- D205 D206 D207

\* 240 YOU  
 USE WITH T  
 R231 W  
 R232  
 D208  
 D211  
 Q205

NOTES:

- ▲ MARK BY COILS L9, L10, L11, L12, L14 & L15 SHOWS LONG SIDE. (UPPER COIL OF WIRE).

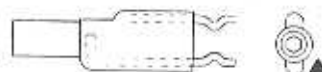

- PARTS SHOWN IN BROKEN LINES MOUNTED ON OPPOSITE SIDE OF BOARD. R77 & D8.

- COMPONENT LEADS SHALL NOT EXTEND MORE THAN .040/.060 FROM BOTTOM OF P.C. BOARD AFTER LEAD TRIMMING.

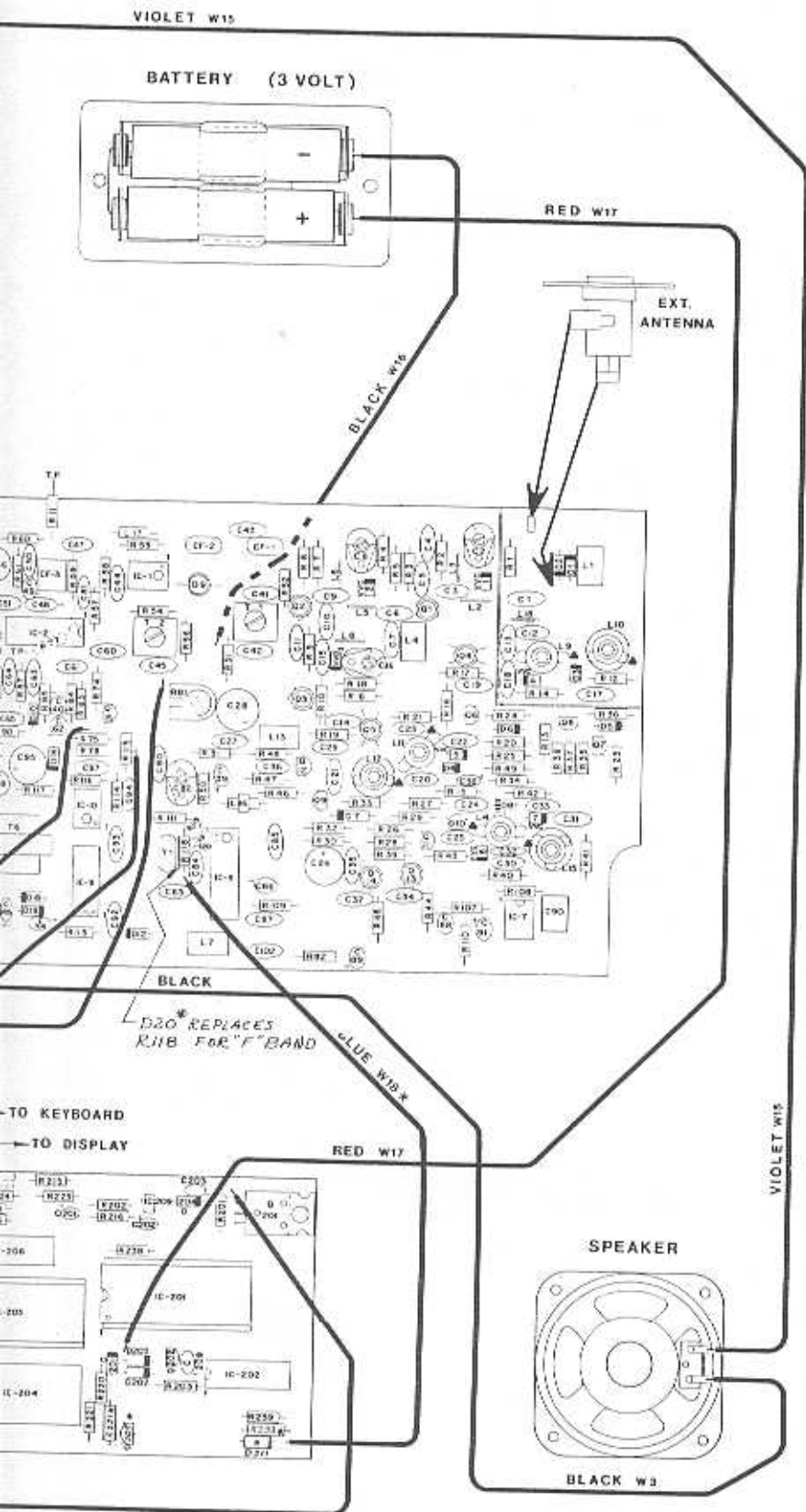

40 VOLT  
WITH F BAND ONLY  
W18, BLUE

RF BOARD

LAST NO. USED		NO'S. NOT USED
R120	VVC-7	R55
C106	IC-10	R86
D19	CF-3	R112
Q18	JW-1	C103
L18	Y1	D17
T6		

PARTS LIST

BC-220

<u>PLACEMENT</u>	<u>DESCRIPTION</u>	<u>ELECTRA NUMBER</u>
	Keyboard	BC68-601
	P.C. Board, Feature	BD27-501
	P.C. Board, Radio	BD29-601
C10	.47PF 10% Cer Disc	CA46-001
C32	8.2 PF 5% NPO Mini Cap	CJ01-082
C6	47 PF 5% N75 Mini Cap	CJ07-470
C2,C8,C16,C82	1.7-16 PF Plas. Var. Cap	CB74-301
C83	82 PF 5% NPO PTPI	C101-820
C43	5 PF 10% NPO 100V Cer	C102-050
C13	6.8 PF 10% NPO 100V Cer	C102-068
C14,C41,C51	10 PF 10% NPO 100V Cer	C102-100
C3,C5	15 PF 10% NPO 100V Cer	C102-150
C12	1 PF NPO +/- .25 100V Cer	C103-010
C1,C25	2.2 PF +/- .25 NPO 100 V Cer	C103-022
C59	47 PF 5% N150 CD Cap	C110-470
C30	12 PF 5% N750 CW PTPI Cap	C111-120
C7	15 PF 10% N750 Cer Cap PTPI	C112-150
C80	47 PF 10% NPO PTPI Cer Disc	C115-470
C9,C15,C23,C31	68 PF 10% N1500 Cer Disc	C122-680
C27	180 PF 10% Y5F Cer	C132-181
C34,C37,C92	100 PF 20% Y5F 500V Cer	C133-101
C24	150 PF 20% Y5F	C133-151
C17,C19,C20	220 PF 20% Y5F PTPI Cer Disc	C133-221
C18,C22,C64,C65, C81,C84,C85,C87	470 PF 20% Y5F 500V Cer	C133-471

<u>PLACEMENT</u>	<u>DESCRIPTION</u>	<u>ELECTRA NUMBER</u>
C35	680 PF Y5F 20% PTPI Cer	C133-681
C44,C45,C55,C56 C60,C63,C67,C72, C94,C104	.01 MF Z5U 20% 12V PTPI Cer	C301-103
C54,C57,C68,C75	.05 MF 20% 12V Z5U Cer PTPI	C301-503
C21,C42,C53,C97 C99	.02 MF 20% Z5U 50V Cer	C303-203
C4,C11,C29,C33 C61,C102	.001 MF 20% 100V Z5U Disc Cer PTPI	C304-102
C70,C71,C76	.002 MF Z5U 20% 100V Cer Disc PTPI	C304-202
C36	.005 MF 20% Z5U 100V Cer	C304-502
C47,C50,C78,C93, C100	.0 MF +80-20% X5U 12V Cer	C331-104
C90	.22 MF 10% 35V Mylar	C501-224
C66,C69	.0033 MF 10% Z5P 100V Mylar	C503-332
C48,C49,C91, C206,C208	1 MF 20% 10V Tant	C602-105
C205,C207	2.2 MF 10V Tant	C602-225
C38,C40,C62	.47 MF 20% 10V Tant	C602-474
C201,C202,C203, C209,C210	47 MF 20% 10V Tant	C602-476
C86	4.7 MF 20% 16V Tant	C603-475
C88	.1 MF 20% 25V Tant	C605-104
C204	.1 MF 20% 35V Tant	C606-104
C89,C105,C106	4.7 MF 35V Tant	C606-475
C101	2200 MF 25V Elect TT	C707-228
C58	10 MF 10V -10/+100 TW Elect	C732-106
C73,C74,C98	22 MF +100/-10 16V TW Elect	C733-226
C46,C95	220 MF -10/+100 16V Elect TW	C733-227
C26,C28,C96	47 MF +100/-10 16V TW Cap	C733-476



<u>PLACEMENT</u>	<u>DESCRIPTION</u>	<u>ELECTRA NUMBER</u>
C77,C79	100 MF +80/20% 10V Elect TW	C751-107
C39,C52	47 MF +80-20 10V	C751-476
D9	National #NSL5046 L.E.D. Red	DA28-701
D13,D14,D15	Gen. Inst. #IN4002 or IN4002 G.P.	DB70-301
VVC4,VVC5, VVC6,VVC7	Siemens #BB209 Tuning Diode Matched	DB70-601
VVC1,VVC2,VVC3	Siemens #BB105A Tuning Diode Matched	DB70-701
D210	APD IN5233B 6V 5% Zener	DB72-302
D3,D4,D8	Siemens BA244	DB73-102
D1,D2,D5,D6, D10,D11,D21, D12,D16,D18, D19,D201,D202, D203,D209,D213	Hitachi IN4148	DB73-602
D204	IN5240B 10V Zener Diode	DF10-401
D7,D212	IN5231 5V Zener Diode APD	DB92-603
Ant. Connector	9/32 Odx. 133IDX.025 Thk Washer	FA36-801
Mounting Bracket	Nylon Shoulder Washer	FA57-801
Serial Tag	Rivet, Steel 1/8 X .155Avdel	FB80-901
Feet	Rivet 1/8 x .235	FB80-902
Connector	Rivet Stl 1/8 x 3/16 Semi-tubular ZO	F102-000
Mobile Mounting Bracket	1/4 ID x 9/16 OD Flat Washer Cad	F202-000
Antenna Bushing	#10 Internal Washer Cad	F205-000
Display Holder	Spring Washer .283 OD	F210-000
Antenna Bushing	10/32 x 5/16 Hex Nut Cad	F306-000
Power Transformer	#8 Internal Tooth Lockwasher Zinc	F321-000
Speaker Jack	Int. TTH. Lock Washer .256/.267 I.D.	F322-000
JB598	Nut M 6 x 0.5	F323-000
Display Holder	Spring Clip .125 ID	F401-000
	Antenna Insulator	HA21-501

<u>PLACEMENT</u>	<u>DESCRIPTION</u>	<u>ELECTRA NUMBER</u>
	Insulator AC	HA62-101
	Logo Inlay	HA91-001
	Plug Button	HA97-701
	Bracket, Mobile Mounting	HB23-402
	Knob	HB46-402
	Inlay Volume	HB46-504
	Keytop, Orange	HB82-501
	Keytop, Beige	HB82-503
	Keytop, Yellow Ochre	HB82-504
	Keytop, Blue	HB82-506
	Control Inlay	HB85-201
	Foot	HB89-001
	Snap Bushing	HB89-903
	Antenna Bushing	HB91-601
	Battery Door	HB94-201
	Antenna Ground Strap	HB95-701
	Display Holder	HC51-701
	Metal Serial Tag	HC60-419
	Mounting Bracket	HC66-401
	RF Shield	HC66-902
	Cover, AC	HC67-501
	Keyboard Inlay	HC69-001
	Front Panel	HD11-303
	Wrap	HD11-403
	Chassis Assembly	HD22-303
	Keytop Cushion	HF10-801

<u>PLACEMENT</u>	<u>DESCRIPTION</u>	<u>ELECTRA NUMBER</u>
	Antenna Plug	JA12-701
	Terminal Bushing Heyco DC251-1	JA22-202
	Terminal T101-S	JA22-203
	Antenna Connector	JA36-201
Use w/IC-202 & IC-207	16 Pin I.C. Socket Assy.-Scanbe	JA58-402
Use w/IC-8	Samtec 18 Pin I.C. Socket Assy.	JA88-102
	Jack - Earphone 3.5MM Diameter	JB60-501
Use w/IC-204	24 Pin I.C. Socket - Scanbe	JB88-702
	AC Interlock Receptacle	JB95-201
	Connector, Top Entry	JC65-701
Use w/IC-201 & IC-203	28 Pin I.C. Socket	JD38-301
L1	Choke, White	LA21-801
L4,L7	Choke, Blue	LA21-804
L13	Choke, Green	LA21-805
L8	Coil	LA50-801
L2,L3,L5	Coil	LA50-802
L6	UHF Coil	LA50-803
L18	Choke	LA50-901
L16	Choke Wound on Coil Form	LA96-001
L17	Choke	LB46-304
L9,L11	Coil	LB50-104
L10,L12	Coil	LB51-102
L15	Coil, 12 1/3 Turns Alum.	LB51-103

<u>PLACEMENT</u>	<u>DESCRIPTION</u>	<u>ELECTRA NUMBER</u>
L14	Coil, Hi Band Osc.	LC76-201
	Antenna	MA13-802
	2 Amp-3AG Fuse	MA37-602
	Fuse Holder	MA62-201
	Terminal, Fully Insulated	MA64-001
	Terminal	MA64-901
	Contact Fuse	MA65-201
	Heat Sink, I.C.	MA80-501
	Spring	MA90-201
	Speaker	MB33-202
	Display 11 Digit Numeric	MC68-501
	1½ Volt Battery Holder	MC71-602
	A.C. Power Cord	MC80-104
IC8	DS8966 Custom IC 175MHz Synthesizer	NA80-601
IC2	IC IF 16 Pin SC8780P B1841	NB53-101
IC10	National #LM386N	NB66-801
IC208	Motorola #MC14011CP	NB67-901
IC5, IC205	National #LM358N	NB73-402
IC206	National DS8654N IC	NB86-201
IC204	National MM5781NED/N	NB89-102
IC7	CA3140AE Loop Filter OP Amp I.C.	NB91-801
IC3	CA3088AE AM Det. I.C.	NB91-901
IC201	MM5785 Cops RAM Interface I.C.	NB92-101
IC202	HM6508 CMOS RAM Harris	NB92-202

<u>PLACEMENT</u>	<u>DESCRIPTION</u>	<u>ELECTRA NUMBER</u>
	Antenna Plug	JA12-701
	Terminal Bushing Heyco DC251-1	JA22-202
	Terminal T101-S	JA22-203
	Antenna Connector	JA36-201
Use w/IC-202 & IC-207	16 Pin I.C. Socket Assy.-Scanbe	JA58-402
Use w/IC-8	Samtec 18 Pin I.C. Socket Assy.	JA88-102
	Jack - Earphone 3.5MM Diameter	JB60-501
Use w/IC-204	24 Pin I.C. Socket - Scanbe	JB88-702
	AC Interlock Receptacle	JB95-201
	Connector, Top Entry	JC65-701
Use w/IC-201 & IC-203	28 Pin I.C. Socket	JD38-301
L1	Choke, White	LA21-801
L4,L7	Choke, Blue	LA21-804
L13	Choke, Green	LA21-805
L8	Coil	LA50-801
L2,L3,L5	Coil	LA50-802
L6	UHF Coil	LA50-803
L18	Choke	LA50-901
L16	Choke Wound on Coil Form	LA96-001
L17	Choke	LB46-304
L9,L11	Coil	LB50-104
L10,L12	Coil	LB51-102
L15	Coil, 12 1/3 Turns Alum.	LB51-103

<u>PLACEMENT</u>	<u>DESCRIPTION</u>	<u>ELECTRA NUMBER</u>
IC207	DS3654 Digit Driver I.C.	NB92-301
IC209	Regulator 78L05AC 5V Texas Inst.	NB92-413
IC9	MC14024 Motorola 7-stage Counter IC	NB92-702
IC1	LM3053 I.F. Amp I.C.	NB93-701
IC4	SGS/ATES TCA 830S Audio Amplifier	NC66-301
IC203	Cops MM 5782N IC	NC73-901
IC6	Regulator, T.I. 7805C	NC81-711
Q4,Q5	Gen. Inst. MEM 636	QA15-702
Q203	Motorola MPS H-17 EL#617	QB72-501
Q1,Q2,Q3, Q13,Q14	Motorola #2N5179	QB72-603
Q18	T.I. # Tip 30	QB74-401
Q201	T.I. # Tip 29	QB74-501
Q17,Q18	National #92PE77A	QB76-402
Q204	NPC Darlington NPM A13	QB82-002
Q12	MPD 820 J Fet Transistor	QB91-701
Q9	MPS A62	QB93-601
Q6,Q7,Q8,Q15, Q16,Q202,Q206,	National #MPS3393 Process 07	QC58-102
Q10,Q11	Motorola #MPS3640 SPS758 EL271	QC59-202
R81	Res. 200K Trimpot Piher PT10V	RB71-505
R94	Pot - Switch 100K	RC53-602
R79	Pot - Switch 100K	RC53-604
R93,R104,R113,R117, R118,R205,R219	1 Ohm $\frac{1}{4}$ 10%	R100-010
R105	2.2 Ohm $\frac{1}{4}$ W Gen Res	R100-022
R16,R76,R116	10 Ohm $\frac{1}{4}$ W Gen Res	R100-100

<u>PLACEMENT</u>	<u>DESCRIPTION</u>	<u>ELECTRA NUMBER</u>
R30, R47, R51, R56, R69, R91, R202, R217, R223, R224, R225, R226, R227, R228, R229, R230	100 Ohm $\frac{1}{2}$ W Gen Res	R100-101
R6, R42, R111, R115, R212, R213, R214, R233	1K $\frac{1}{2}$ W Gen Res	R100-102
R12, R22, R23, R34, R46, R67, R74, R77, R221	10K $\frac{1}{2}$ W Gen Res	R100-103
R207	100K $\frac{1}{2}$ W Gen Res	R100-104
R109	1M $\frac{1}{2}$ W Gen Res	R100-105
R71, R72, R107	12K $\frac{1}{2}$ W Gen Res	R100-123
R29, R53, R59, R60, R78	1.5K $\frac{1}{2}$ W Gen Res	R100-152
R25, R27, R38, R66	15K $\frac{1}{2}$ W Gen Res	R100-153
R10	150K $\frac{1}{2}$ W Gen Res	R100-154
R208, R211	1.5M $\frac{1}{2}$ W Gen Res	R100-155
R108	18K $\frac{1}{2}$ W Gen Res	R100-183
R206	180K $\frac{1}{2}$ W Gen Res	R100-184
R31	22 Ohm $\frac{1}{2}$ W Gen Res	R100-220
R9, R24, R52, R68, R204, R216, R220, R222	2.2K $\frac{1}{2}$ W Gen Res	R100-222
R7, R11, R19, R21, R36, R37, R62, R95, R96, R97 (R112- 216kHz only)	22K $\frac{1}{2}$ W Gen Res	R100-223
R85	24K $\frac{1}{2}$ W Gen Res	R100-243
R44, R45	270 Ohm $\frac{1}{2}$ W Gen Res	R100-271
R110	270K $\frac{1}{2}$ W Gen Res	R100-274
R75	2.7M $\frac{1}{2}$ W Gen Res	R100-275

<u>PLACEMENT</u>	<u>DESCRIPTION</u>	<u>ELECTRA NUMBER</u>
IC207	DS3654 Digit Driver I.C.	NB92-301
IC209	Regulator 78L05AC 5V Texas Inst.	NB92-413
IC9	MC14024 Motorola 7-stage Counter IC	NB92-702
IC1	LM3053 I.F. Amp I.C.	NB93-701
IC4	SGS/ATES TCA 830S Audio Amplifier	NC66-301
IC203	Cops MM 5782N IC	NC73-901
IC6	Regulator, T.I. 7805C	NC81-711
Q4,Q5	Gen. Inst. MEM 636	QA15-702
Q203	Motorola MPS H-17 EL#617	QB72-501
Q1,Q2,Q3, Q13,Q14	Motorola #2N5179	QB72-603
Q18	T.I. # Tip 30	QB74-401
Q201	T.I. # Tip 29	QB74-501
Q17,Q18	National #92PE77A	QB76-402
Q204	NPC Darlington NPM A13	QB82-002
Q12	MPD 820 J Fet Transistor	QB91-701
Q9	MPS A62	QB93-601
Q6,Q7,Q8,Q15, Q16,Q202,Q206,	National #MPS3393 Process 07	QC58-102
Q10,Q11	Motorola #MPS3640 SPS758 EL271	QC59-202
R81	Res. 200K Trimpot Piher PT10V	RB71-505
R94	Pot - Switch 100K	RC53-602
R79	Pot - Switch 100K	RC53-604
R93,R104,R113,R117, R118,R205,R219	1 Ohm $\frac{1}{4}$ 10%	R100-010
R105	2.2 Ohm $\frac{1}{4}$ W Gen Res	R100-022
R16,R76,R116	10 Ohm $\frac{1}{4}$ W Gen Res	R100-100



<u>PLACEMENT</u>	<u>DESCRIPTION</u>	<u>ELECTRA NUMBER</u>
R30, R47, R51, R56, R69, R91, R202, R217, R223, R224, R225, R226, R227, R228, R229, R230	100 Ohm $\frac{1}{2}$ W Gen Res	R100-101
R6, R42, R111, R115, R212, R213, R214, R233	1K $\frac{1}{4}$ W Gen Res	R100-102
R12, R22, R23, R34, R46, R67, R74, R77, R221	10K $\frac{1}{4}$ W Gen Res	R100-103
R207	100K $\frac{1}{4}$ W Gen Res	R100-104
R109	1M $\frac{1}{4}$ W Gen Res	R100-105
R71, R72, R107	12K $\frac{1}{4}$ W Gen Res	R100-123
R29, R53, R59, R60, R78	1.5K $\frac{1}{4}$ W Gen Res	R100-152
R25, R27, R38, R66	15K $\frac{1}{4}$ W Gen Res	R100-153
R10	150K $\frac{1}{4}$ W Gen Res	R100-154
R208, R211	1.5M $\frac{1}{4}$ W Gen Res	R100-155
R108	18K $\frac{1}{4}$ W Gen Res	R100-183
R206	180K $\frac{1}{4}$ W Gen Res	R100-184
R31	22 Ohm $\frac{1}{4}$ W Gen Res	R100-220
R9, R24, R52, R68, R204, R216, R220, R222	2.2K $\frac{1}{4}$ W Gen Res	R100-222
R7, R11, R19, R21, R36, R37, R62, R95, R96, R97 (R112- 216kHz only)	22K $\frac{1}{4}$ W Gen Res	R100-223
R85	24K $\frac{1}{4}$ W Gen Res	R100-243
R44, R45	270 Ohm $\frac{1}{4}$ W Gen Res	R100-271
R110	270K $\frac{1}{4}$ W Gen Res	R100-274
R75	2.7M $\frac{1}{4}$ W Gen Res	R100-275

<u>PLACEMENT</u>	<u>DESCRIPTION</u>	<u>ELECTRA NUMBER</u>
R2	330 Ohm $\frac{1}{4}$ W Gen Res	R100-331
R13, R15, R102, R240	3.3K $\frac{1}{4}$ W Gen Res	R100-332
R1, R4, R14, R18, R20, R40, R41, R73, R238, R239	33K $\frac{1}{4}$ W Gen Res	R100-333
R209, R210	330K $\frac{1}{4}$ W Gen Res	R100-334
R3	3.9K $\frac{1}{4}$ W Gen Res	R100-392
R32, R58	39K $\frac{1}{4}$ W Gen Res	R100-393
R82	47 Ohm $\frac{1}{4}$ W 10%	R100-470
R49, R65, R70, R201	470 Ohm $\frac{1}{4}$ W Gen Res	R100-471
R28, R39, R48, R50, R98, R99, R100, R101, R103, R114	4.7K $\frac{1}{4}$ W Gen Res	R100-472
R61, R63, R84	47K $\frac{1}{4}$ W Gen Res	R100-473
R17, R87	470K $\frac{1}{4}$ W Gen Res	R100-474
R92	56 Ohm $\frac{1}{4}$ W Gen Res 5%	R100-560
R88	5.6K $\frac{1}{4}$ W Gen Res	R100-562
R86	68 Ohm $\frac{1}{4}$ W Gen Res	R100-680
R90	680 Ohm $\frac{1}{4}$ W Gen Res	R100-681
R80	56K $\frac{1}{4}$ W Gen Res	R100-563
R5, R26, R35, R57, R203	6.8K $\frac{1}{4}$ W Gen Res	R100-682
R54, R64	68K $\frac{1}{4}$ W Gen Res	R100-683
R43	820 Ohm $\frac{1}{4}$ W Gen Res	R100-821
R8, R83, R89, R234	8.2K $\frac{1}{4}$ W Gen Res	R100-822
R33	82K $\frac{1}{4}$ W Gen Res	R100-823
R215	470 Ohm $\frac{1}{4}$ W 5% Res CF	R101-471
R119, R120	1 Ohm $\frac{1}{4}$ W Gen Res LL	R150-010

<u>PLACEMENT</u>	<u>DESCRIPTION</u>	<u>ELECTRA NUMBER</u>
R106	2.2M ½W 10% Carbon Comp Res LL	R214-225
T3	Coil, Quad 400kHz	LB53-101
T4	IF Transformer Black	TB31-101
T1	IF Transformer	TB52-003
T2	IF Transformer	TB93-301
T6	DC Converter	TC64-201
T5	Power Transformer	TC65-401
Mobile Mounting Bracket	¼-20X½ HH Cad	U201-000
PC Board to Chassis	6 X 3/8 Hex Washer Head Slt'd Type A	U222-000
Panel to Chassis	6 X 5/16 Phil Hd Type 25 Cad	U234-000
Wrap to Chassis Spkr. to Chassis Btry. Cover to Chas.	6 X ¼ Slotted Hex W Head Type A Black	U242-000
Trans. to Chassis	8 X 3/8 Holt Pan Hd. Type BA Zinc OR	U251-000
DC Grnd. Cable	#6 X ¼ Slt'd Hex Wshr Hd Type A,Z O	U258-000
Keyboard to FB FB to Mtg. Bracket	4 X 3/8 HWH 17 Type A Zinc or Cad	U259-000
Display to Feature Board	Flexible Jumper 20 Cond.	WA54-708
	Jumper	WA56-509
	Solid, #22 300V 1/64 PVC, FRI Black	W100-000
	Solid, #22 300V 1/64 PVC FRI Black	W101-000
	Solid, #22 300V 1/64 PVC FRI Red	W102-000
	Solid, #22 300V 1/64 PVC FRI Orange	W103-000
	Solid, #22 300V 1/64 PVC FRI Yellow	W104-000
	Solid, #22 300V 1/64 PVC FRI Green	W105-000

<u>PLACEMENT</u>	<u>DESCRIPTION</u>	<u>ELECTRA NUMBER</u>
R2	330 Ohm $\frac{1}{4}$ W Gen Res	R100-331
R13, R15, R102, R240	3.3K $\frac{1}{4}$ W Gen Res	R100-332
R1, R4, R14, R18, R20, R40, R41, R73, R238, R239	33K $\frac{1}{4}$ W Gen Res	R100-333
R209, R210	330K $\frac{1}{4}$ W Gen Res	R100-334
R3	3.9K $\frac{1}{4}$ W Gen Res	R100-392
R32, R58	39K $\frac{1}{4}$ W Gen Res	R100-393
R82	47 Ohm $\frac{1}{4}$ W 10%	R100-470
R49, R65, R70, R201	470 Ohm $\frac{1}{4}$ W Gen Res	R100-471
R28, R39, R48, R50, R98, R99, R100, R101, R103, R114	4.7K $\frac{1}{4}$ W Gen Res	R100-472
R61, R63, R84	47K $\frac{1}{4}$ W Gen Res	R100-473
R17, R87	470K $\frac{1}{4}$ W Gen Res	R100-474
R92	56 Ohm $\frac{1}{4}$ W Gen Res 5%	R100-560
R88	5.6K $\frac{1}{4}$ W Gen Res	R100-562
R86	68 Ohm $\frac{1}{4}$ W Gen Res	R100-680
R90	680 Ohm $\frac{1}{4}$ W Gen Res	R100-681
R80	56K $\frac{1}{4}$ W Gen Res	R100-563
R5, R26, R35, R57, R203	6.8K $\frac{1}{4}$ W Gen Res	R100-682
R54, R64	68K $\frac{1}{4}$ W Gen Res	R100-683
R43	820 Ohm $\frac{1}{4}$ W Gen Res	R100-821
R8, R83, R89, R234	8.2K $\frac{1}{4}$ W Gen Res	R100-822
R33	82K $\frac{1}{4}$ W Gen Res	R100-823
R215	470 Ohm $\frac{1}{4}$ W 5% Res CF	R101-471
R119, R120	1 Ohm $\frac{1}{4}$ W Gen Res LL	R150-010

<u>PLACEMENT</u>	<u>DESCRIPTION</u>	<u>ELECTRA NUMBER</u>
	Solid, #22 300V 1/64 PVC Fri Blue	W106-000
	Solid, #22 300V 1/64 PVC Fri Violet	W107-000
	Str. #22 7/30 300V 1/64 PVC Black	W200-000
	Str. #22 7/30 300V 1/64 PVC Red	W202-000
	Str. #18 16/30 600V 1/32 PVC Black	W800-000
	Str. #18 16/30 600V 132 PVC Fri Red	W802-000
	Wire Buss 22 Ga	W922-000
CF3	Ceramic Filter	YA53-505
CF1,CF2	Crystal Filter 10.8MHz	YA60-101
Y1	Crystal 10.4MHz	YA92-402