

JVC

SERVICE MANUAL

MICRO COMPONENT SYSTEM

UX-1^{B/E/G}



COMPACT
disc
DIGITAL AUDIO

B..... U.K.
E..... Continental
 Europe
G..... Germany

Contents

	Page		Page
1	Safety Precautions	2	
2	Safety Precautions about UX-1	3	
3	Features	5	
4	Specifications	5	
5	Instructions (Extract)	6	
6	Location of Main Parts	20	
7	Removal of Main Parts	22	
8	Main Adjustments	31	
9	Block Diagram	36	
10	Wiring Connections	37	
11	Standard Schematic Diagram and Location of P.C. Board Parts	38	
	■ Microcomputer, LCD Display Section		
	■ Circuit Diagram	38	
	■ Display P.C. Board / Jack P.C. Board / Door Close Switch P.C. Board / CD Door Open Switch P.C. Board / CD Door Motor P.C. Board / External Antenna Terminal P.C. Board	39	
	■ CD Control Section Circuit Diagram	40	
	■ CD Control P.C. Board	41	
	■ Tuner P.C. Board / Antenna terminal Board	42	
	■ Tuner Section Circuit Diagram	43	
	■ Function Section Circuit Diagram	44	
	■ Function P.C. Board / Electric Volume P.C. Board / Tone Quality Control Volume P.C. Board	45	
	■ CD Operation Section Circuit Diagram	46	
	■ CD Operation P.C. Board	46	
	■ Tape Deck, Pre-amplifier / Mechanism Control Section Circuit Diagram	47	
	■ Power Supply / Power Amplifier Section Circuit Diagram	48	
	■ Pre-amplifier P.C. Board / Headphone Jack P.C. Board / Relay P.C. Board / Tape Deck Operation Key Switch P.C. Board	49	
	■ Reel Motor P.C. Board / Actuator Motor P.C. Board / Cam Switch P.C. Board / Mechanism Control P.C. Board / Leaf Switch P.C. Board	50	
	■ Relay Drive P.C. Board / Power Amplifier P.C. Board / Power Supply, Relay P.C. Board	51	
12	Exploded View of Enclosure Component Parts and Parts List	52	
	CD Receiver Section	52	
	Tape Deck, Amplifier Section	52	
	Cassette Mechanism Section	56	
	CD Mechanism Section	58	
	Speaker System Section	59	
13	Illustration of Packing and Packing Parts List	61	
14	Electrical Parts List	62	

6 Location of Main Parts

CD · Receiver Sections

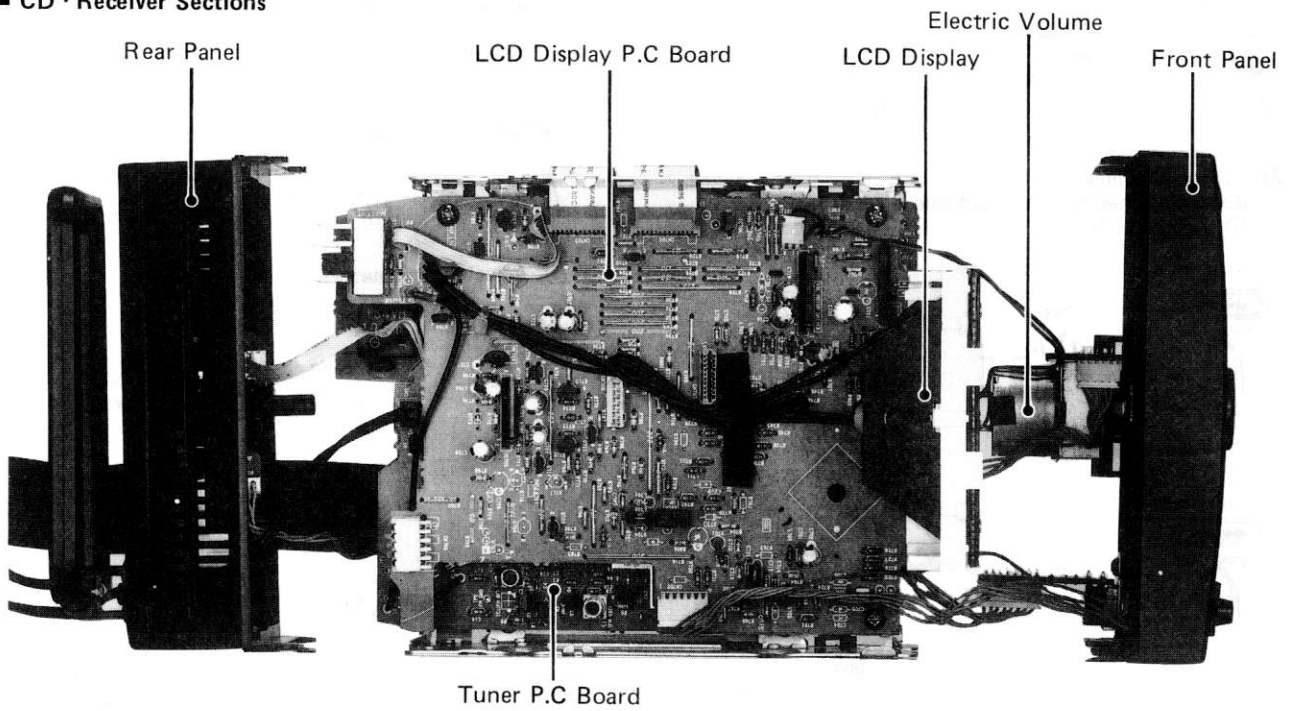

Fig. 6-1

CD Player View

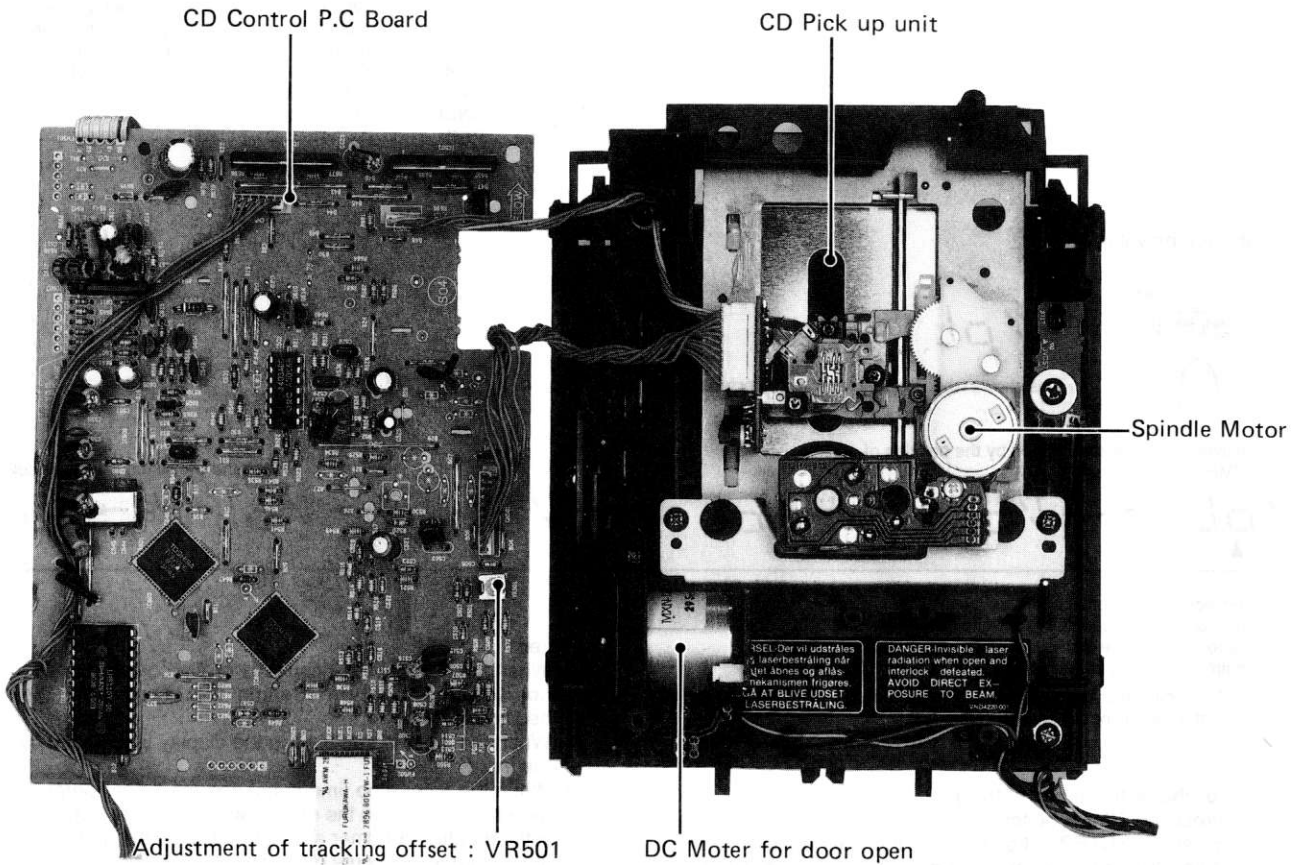

Fig. 6-2

■ Tape Deck · Amplifier Sections

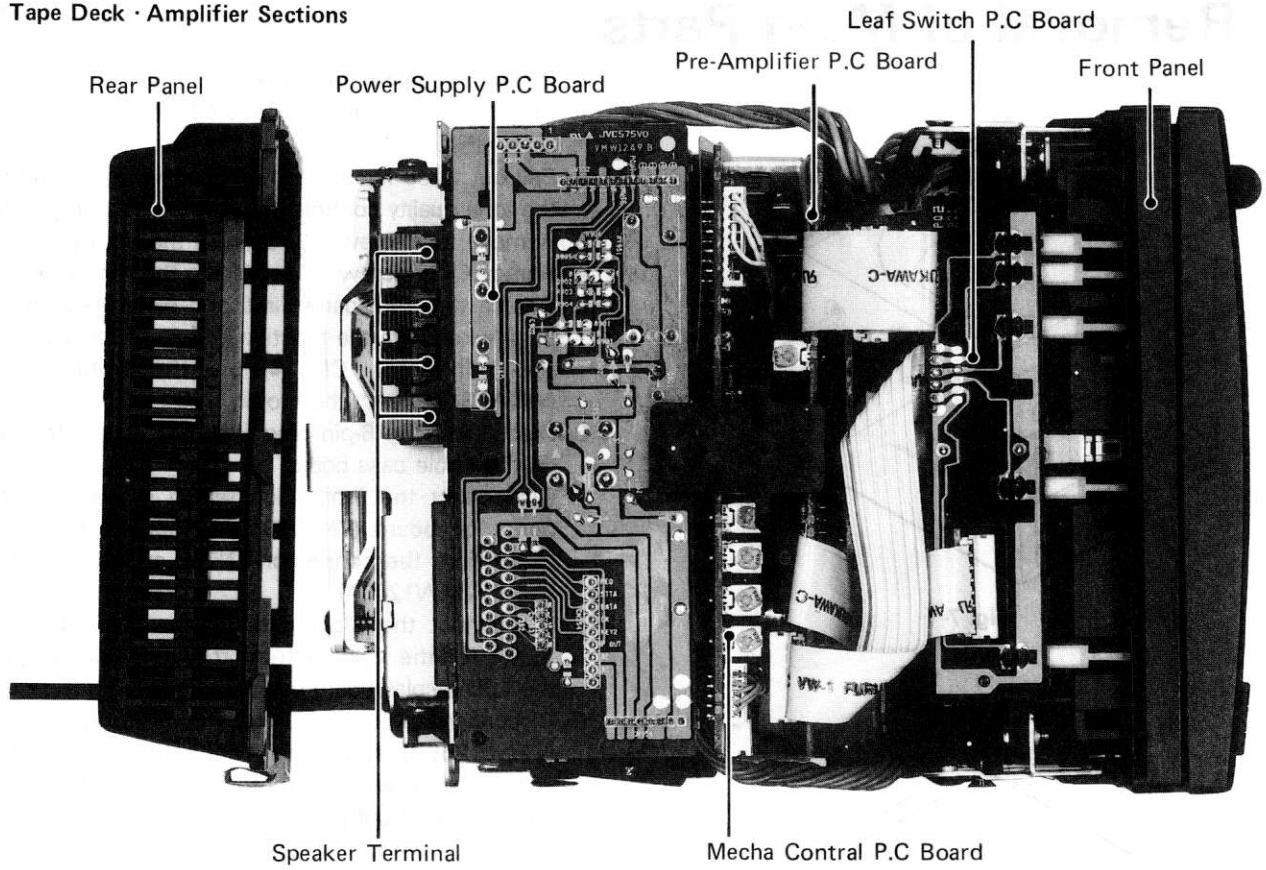

Fig. 6-3

■ Cassette Mechanism Sections

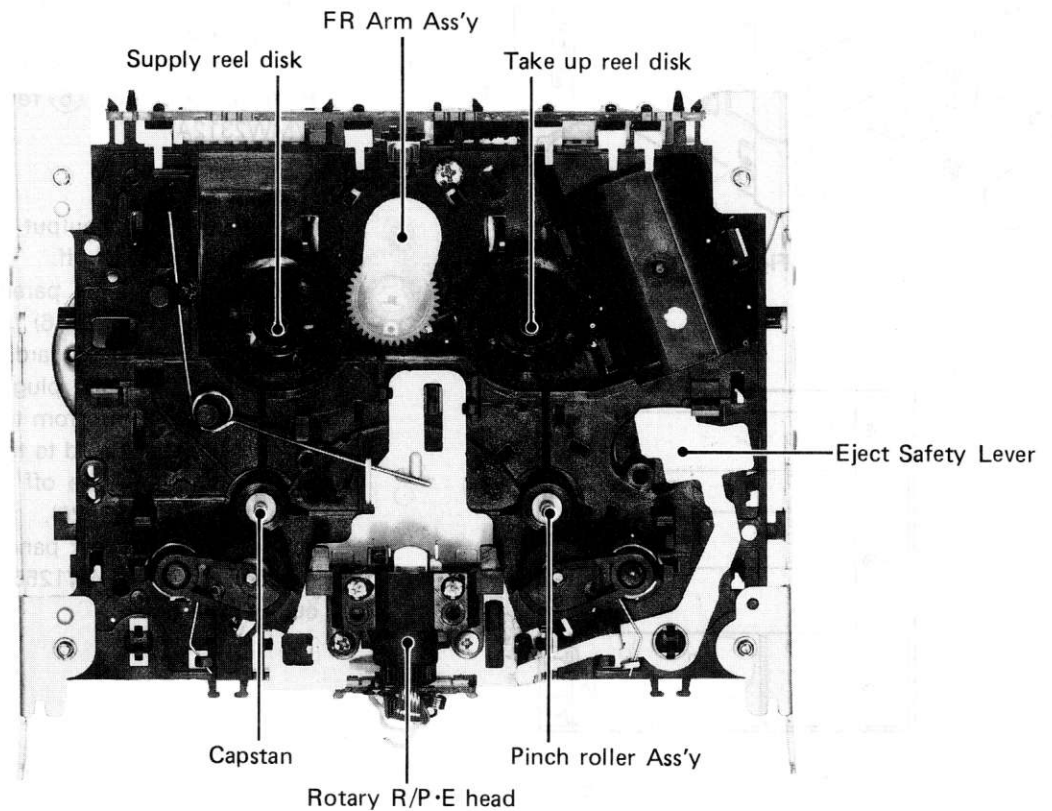

Fig. 6-4

7 Removal of Main Parts

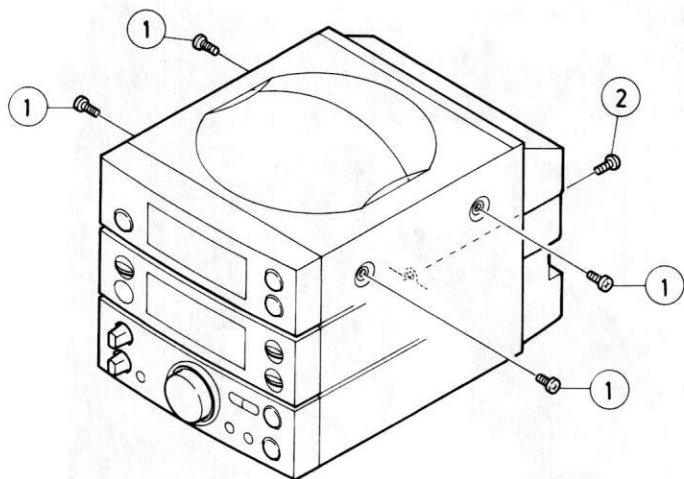

Fig. 7-1

■ CD and Receiver sections

1. Remove five screws (1) and (2) retaining the metal cover. (Fig. 7-1)
2. Pull out three knobs of the sound volume control and the tone quality controls (treble and bass). (Fig. 7-2)
3. Remove four screws (3) retaining the front panel.
4. Remove four screws (4) retaining the rear panel.
5. Detach the front panel first, and disconnect the 5-pin plug (wired with the function board - VMW1255B) from the connector CN314 on the volume board (VMW2312C) with the motor.
6. Disconnect the 8-pin plug from the connector CN313 on the treble bass board.
7. Disconnect the 7-pin plug which is wired with the operation board (VMW2312A) attached to the front panel from the connector CN702 of the LCD display board (VMW1246A).
8. Disconnect the 2-pin plug which is wired with the motor for the volume from the connector CN701 of the LCD display board (VMW1246A).
9. Disconnect the 8-pin plug wire with the function board (VMW1255B) from the connector CN602 of the volume board with the motor (VMW2312B).
10. Take out the front panel.

■ P.C. boards attached to front panel (Fig. 7-3)

1. Remove a screw (5) retaining the volume assembly for tone quality control.
2. Remove nuts with washers retaining the volume assembly with the motor from the front panel, and take out the volume assembly with the motor.
3. Remove six screws (6) retaining the operation board (VMW2312A).

■ Rear panel (Fig. 7-2)

1. Release the audio output cable from the clamp and move the rear panel off.
2. Disconnect the 2-pin parallel wires (wired with the tuner board - VMW2326) from the connector CN1 of the antenna terminal board.
3. Disconnect the 3-pin plug (wired with the function board - VMW1255B) from the connector CN301 of the pin jack board attached to the rear panel.
4. Pull the antenna wire off the connector CN2 of the tuner board (VMW2326).
5. For replacing the rear panel, unsolder JW301 on the function board (VMW1255B) and remove the audio output cable.

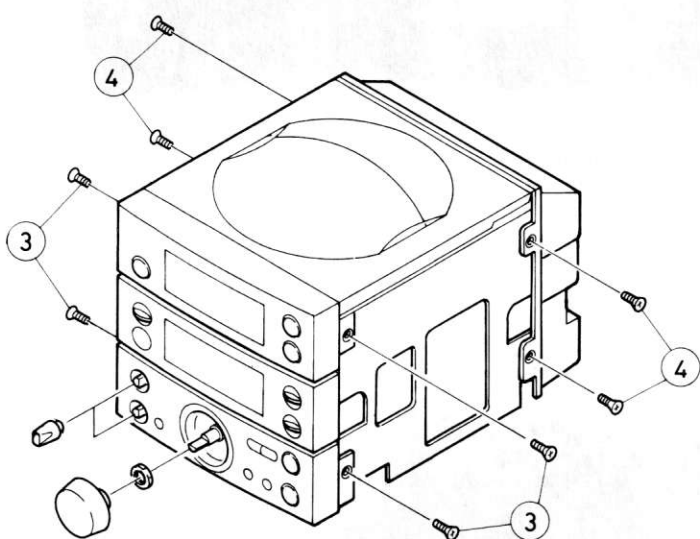

Fig. 7-2

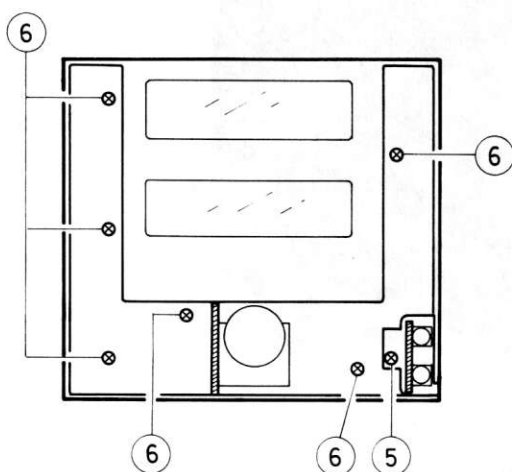

Fig. 7-3

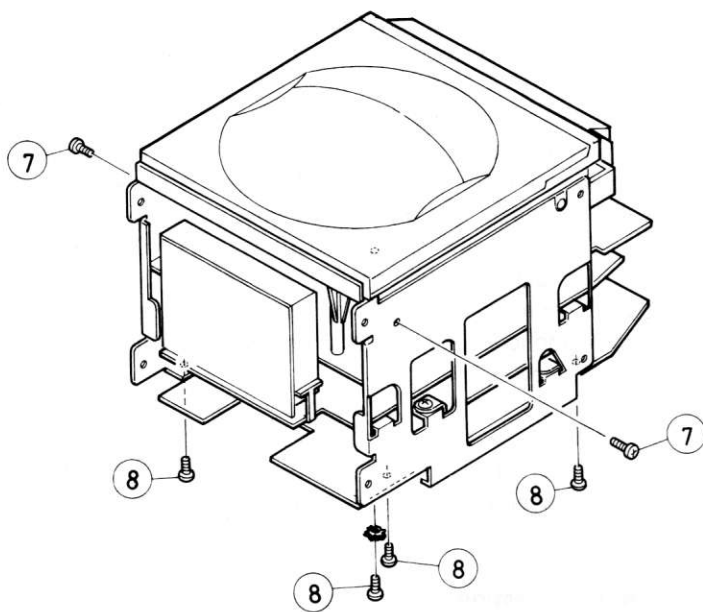

Fig. 7-4

■ CD player assembly (Fig. 7-4)

1. Remove two screws (7) retaining the CD player assembly.
2. Disconnect the parallel wires coming from the connector CN504 of the CD control board (VMW-2307A) from the connector CN707 of the Microcomputer, LCD display board (VMW1255A).
3. Disconnect the 6-pin plug which is wired with the door open/close motor board and the door open switch board from the connector CN706 of the Microcomputer, LCD display board (VMW1255A).
4. Disconnect the 5-pin parallel wires coming from the CD control board (VMW2307) from the connector CN705 of the Microcomputer, LCD display board (VMW1255A).
5. Take out the CD player assembly.

■ Function board (VMW1255B) (Fig. 7-4)

Remove four screws (8) retaining the function board (VMW1255B) from the both sides of the chassis.

■ LCD display board (VMW1255A) (Fig. 7-5)

1. Remove three screws (9) retaining the Microcomputer, LCD display board (VMW1255A) from the both sides of the chassis.
2. Disconnect the wire coming from the Microcomputer LCD display board (VMW1255A) from the post pin of the tuner board (VMW2326).
3. Disconnect the parallel wires coming from the LCD display board (VMW1255A) from the connectors CN302 and CN303 of the function board (VMW1255B).

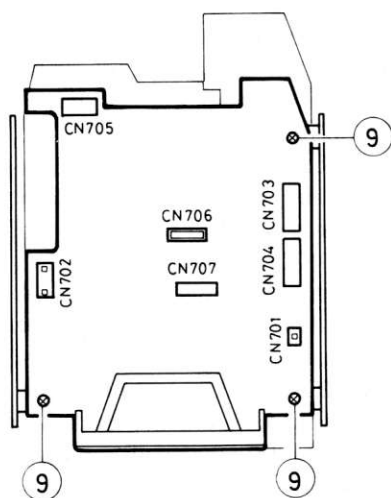

Fig. 7-5

■ Tuner board (VMW2326) (Fig. 7-6)

1. Remove two screws (10) retaining the tuner board from the both sides of the chassis.
2. Disconnect the 10-pin plug wired with the tuner board (VMW2326) from the connector CN301 of the function board (VMW1255B).

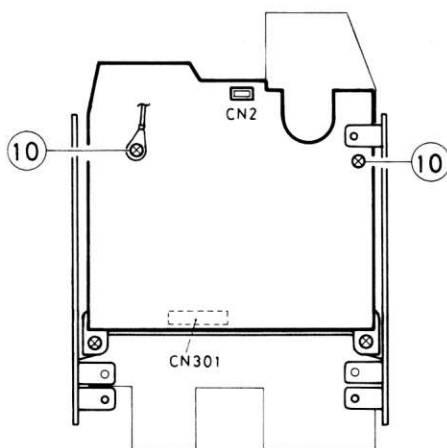

Fig. 7-6

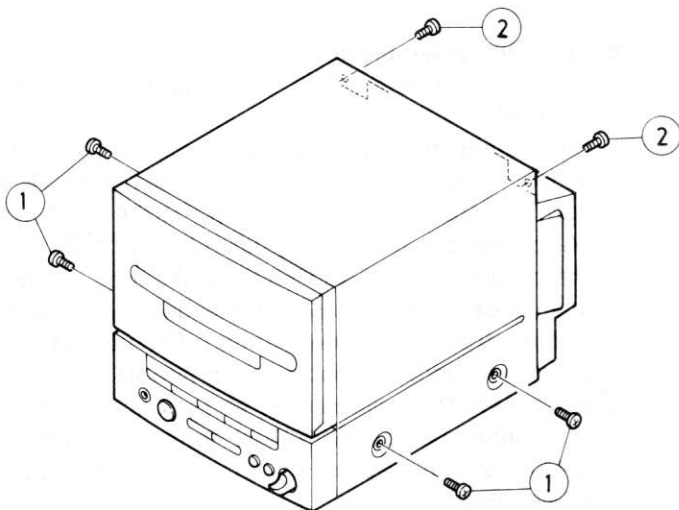

Fig. 7-7

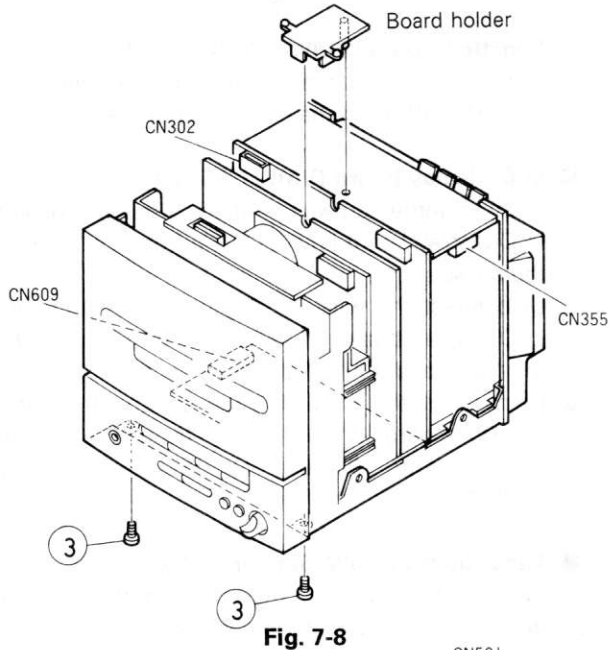

Fig. 7-8

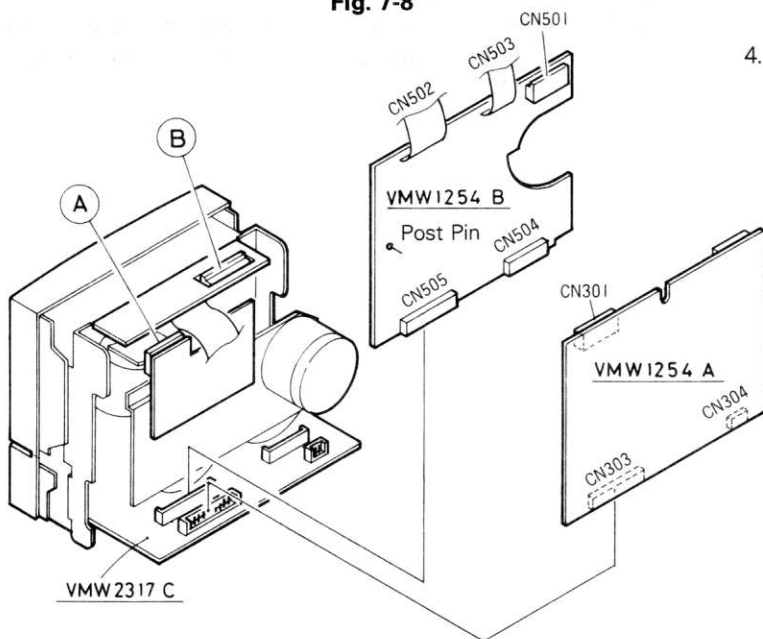

Fig. 7-9

■ **Tape deck and amplifier section**

1. Remove six screws ① and ② retaining the metal cover. (Fig. 7-7), (Fig. 7-8)
2. Detach the board holder.
3. Remove two screws ③ retaining the front panel, the bottom cover and the jack holder together with.
4. Disconnect the 9-pin cable wired with the connector CN354 of the power board (VMW1249B) from the connector CN609 of the preamp board (VMW2317C).
5. Disconnect the 5-pin cable coming from the headphone jack board from the connector CN355 of the power board.
6. Disconnect the 5-pin cable coming from the connector CN353 of the power board (VMW1249B) from the connector CN302 of the preamp board (VMW1254A).
7. Disassemble the power supply section and the deck section from each other.

■ **Deck section** (Fig. 7-9), (Fig. 7-10)

1. Disconnect the 8-pin parallel wires coming from CN502 of the mechanism control board (VMW1254B) from the connector (A) of the reel motor board (VMW3272A) attached to the mechanism.
2. Disconnect the 7-pin parallel wires coming from CN503 of the mechanism control board (VMW1254B) from the connector (B) of the cam switch board (VMW3273A).
3. Disconnect the connectors CN505 and CN504 of the mechanism control board (VMW1254B) from the connectors CN603 and CN604 of the relay board (VMW2317C) respectively.
Disconnect the 6-pin parallel wires coming from the mechanism switch board (VMW1253) from the connector CN501 of the mechanism control board (VMW1254B). Also disconnect the wire coming from the relay board from the post pin of the mechanism control board (VMW1254B).
4. Disconnect the connectors CN303 and CN304 of the preamp board (VMW1254A) from the connectors CN602 and CN603 of the relay board (VMW2317C) respectively.
Disconnect the wires coming from the relay board (VMW2317C) and the head from the connector CN301 of the preamp board (VMW1254A).

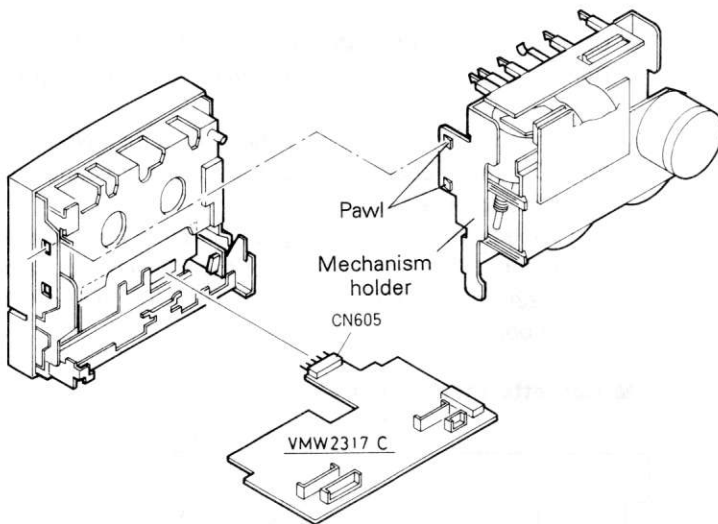

Fig. 7-10

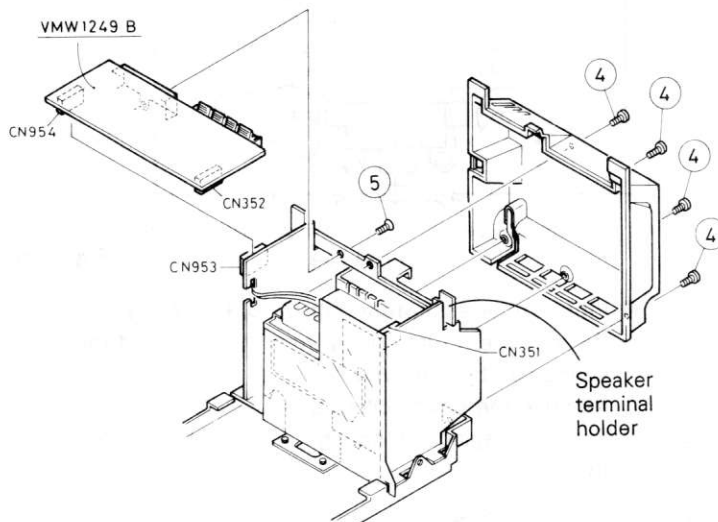

Fig. 7-11

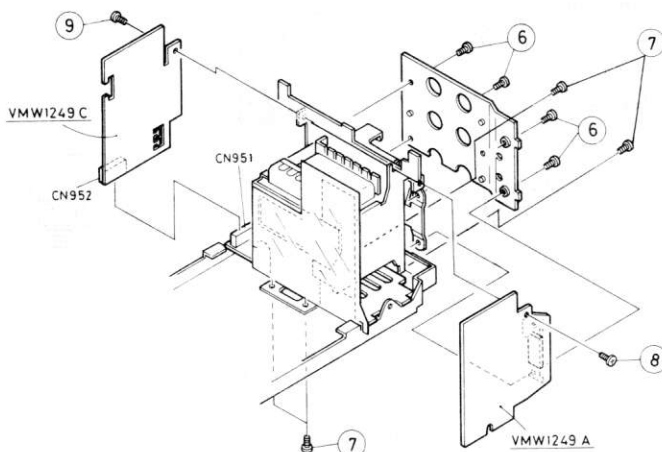

Fig. 7-12

5. Disengage the pawls of the mechanism holders on the both sides of the cassette mechanism from the front panel and detach the cassette mechanism.
6. Disconnect the plug of CN605 of the relay board (VMW2317C) from the connector CN606 of the operation key board (VMW2317A) attached to the front panel.

■ Power supply section (Fig. 7-11, Fig. 7-12)

1. Remove four screws (4) retaining the rear panel.
2. Put the power cord off the groove of the rear panel and take out the rear panel.
3. Remove a screw (5) retaining the connector of the power board (VMW1249B) from the speaker terminal holder.
4. Disconnect connectors CN954 and CN352 of the power board (VMW1249B) from connectors CN953 of the power relay board (VMW1249C) and CN351 of the power amp board (VMW1249A) respectively, and take out the board VMW1249B.
5. Remove four screws (6) retaining the radiation (A).
6. Remove four screws (7) retaining the bottom cover and the transformer bracket.
7. Take off the bottom cover first, and remove a screw (8) retaining the power amp board (VMW1249A) to detach it.
8. Remove a screw (9) retaining the power relay board (VMW1249C).
9. Disconnect the connector CN952 of the power relay board (VMW1249C) from the connector CN951 of the power transformer board (VMW1249D).

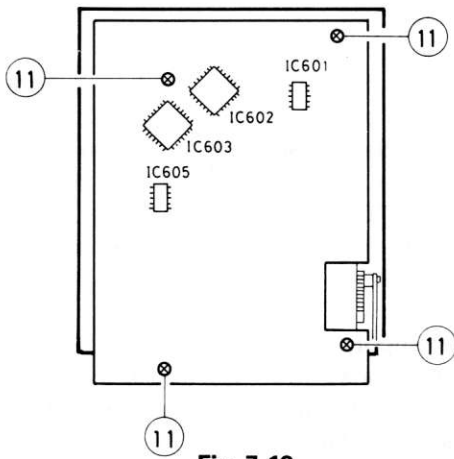

Fig. 7-13

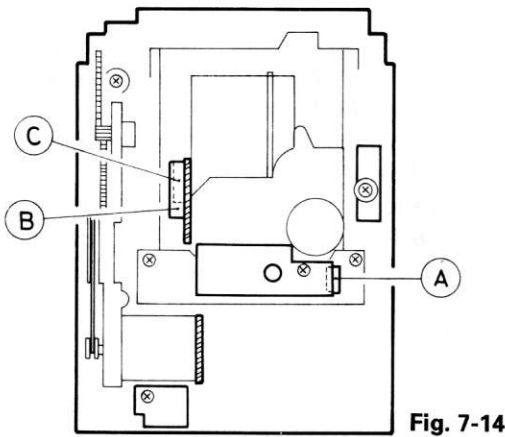

Fig. 7-14

■ **Head mount assembly** (Fig. 7-15, Fig. 7-16)

1. Disengage two pawls securing the head wire relay board.
2. Remove two screws (1) retaining the head mount assembly from the head base.
3. Remove the head gear (1) and the head spring.

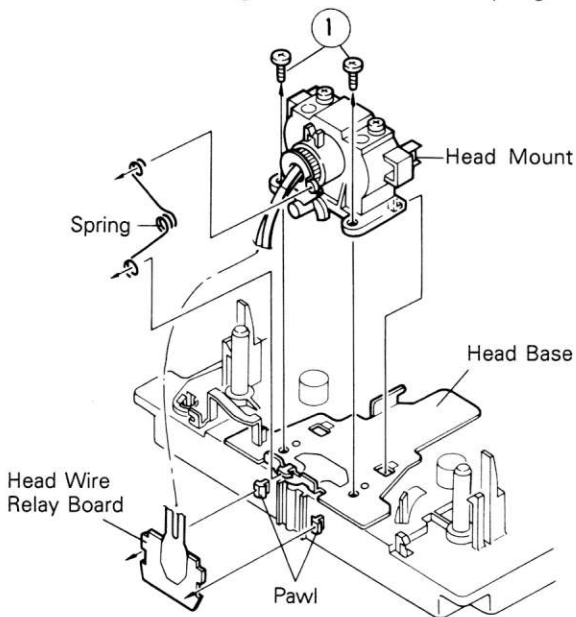

Fig. 7-16

- **CD control board (VMW2307)** (Fig. 7-13), (Fig. 7-14)
1. Remove four screws (11) retaining the CD control board (VMW2307).
 2. Disconnect the 6-pin plug of the connector CN502 of the CD control board (VMW2307) from the connector (A) of the spindle motor board.
 3. Disconnect the 10-pin plug and 4-pin plug of the connectors CN501 and CN503 of the CD control board (VMW2307) from the connectors (B), (C) of the CD pickup board.

■ **Cassette mechanism section**

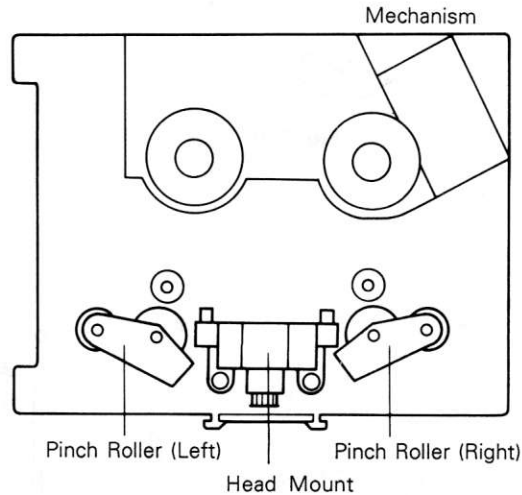

Fig. 7-15

■ **Pinch roller assembly** (Fig. 7-15, Fig. 7-17)

1. Release the return spring from the pawl and the return spring can be removed.
2. Remove the pinch roller spring.
3. For re-engaging the springs, see the figures of (A) and (B).

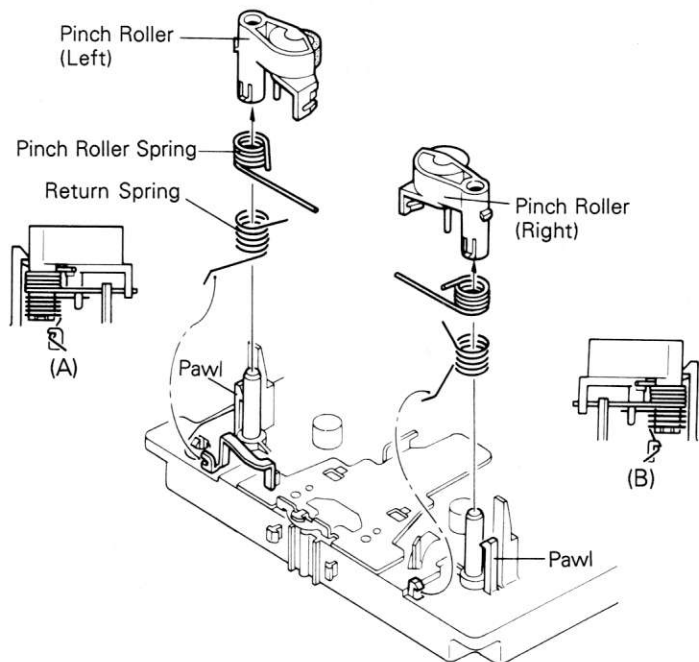

Fig. 7-17

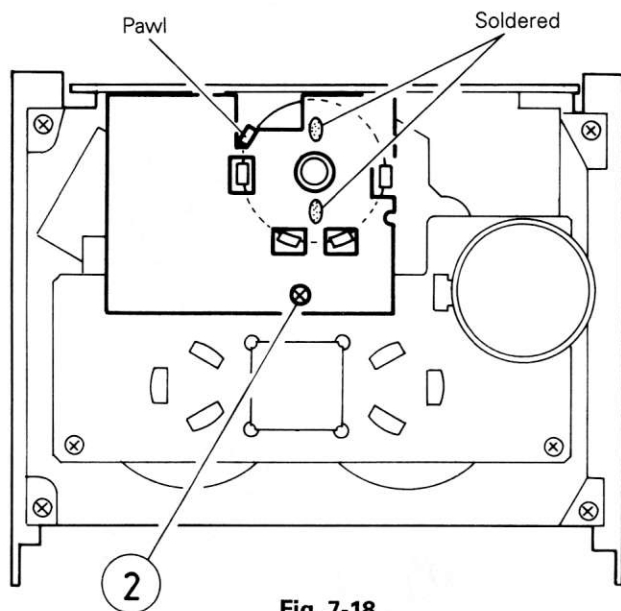

Fig. 7-18

■ **FM bracket/Capstan motor assembly** (Fig. 7-18, Fig. 7-19)

1. Unsolder at the two points connecting the drive motor and the motor board. (Mechanism A or Mechanism B)
2. Remove two screws (2) retaining the FM bracket and capstan motor assembly together with.
3. Remove four fixing screws (3) and disengage five pawls, and the FM bracket and capstan belt can be removed.
4. Remove two screws (4) retaining the capstan motor to the FM bracket.
5. For re-engaging the capstan belt, refer to Fig. 7-20.

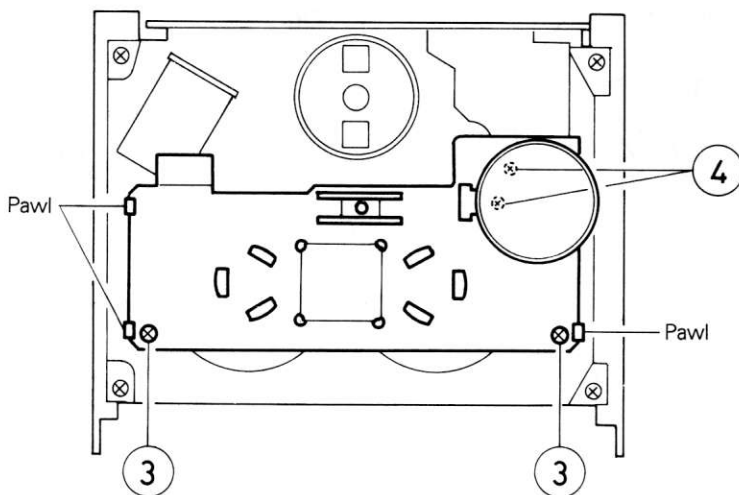
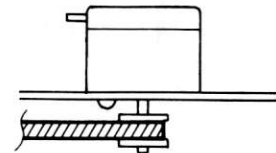

Fig. 7-19

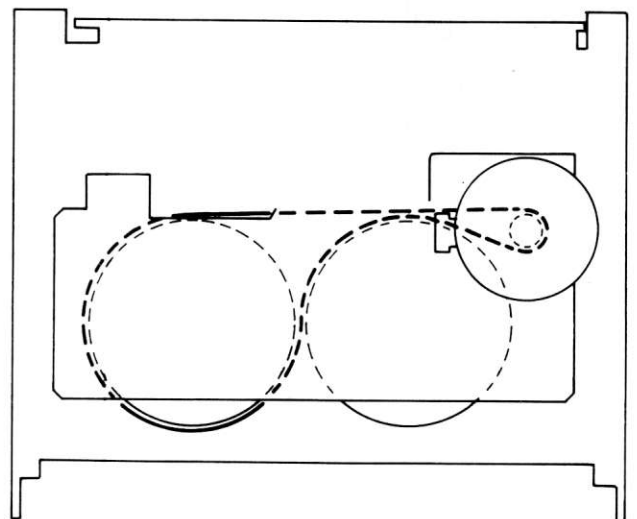

Fig. 7-20

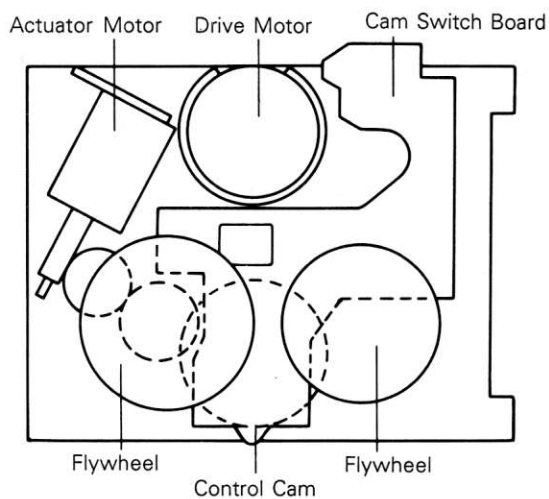

Fig. 7-21

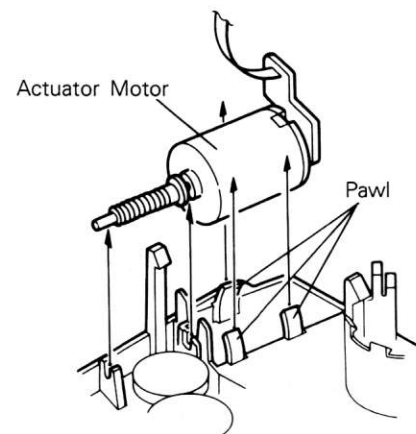

Fig. 7-22

■ **Actuator motor assembly** (Fig. 7-20, Fig. 7-21)

Disengage three pawls securing the actuator motor assembly.

■ **Flywheel assembly** (Fig. 7-21, Fig. 7-23)

Remove the washer engaged on the capstan shaft and pull out the flywheel.

■ **Drive motor** (Fig. 7-21, Fig. 7-24)

1. Pull the gear and the arm assembly out of the drive motor shaft.
2. Remove a screw (5) retaining the drive motor.
3. Disengage four pawls securing the drive motor.

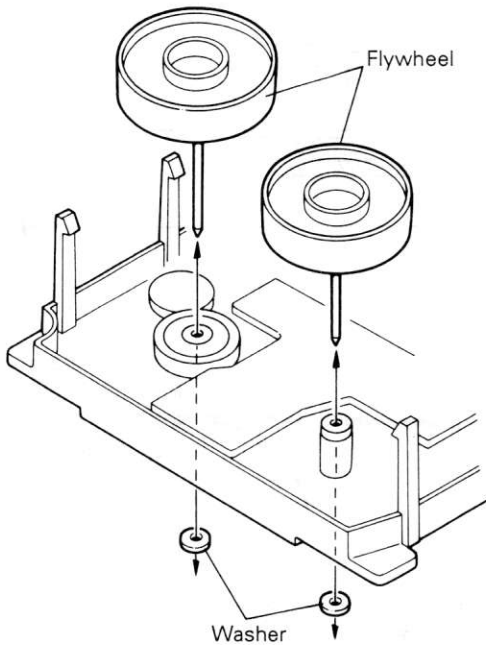

Fig. 7-23

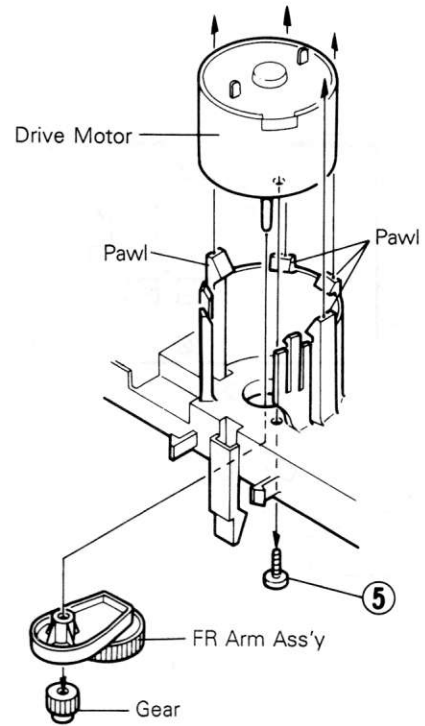

Fig. 7-24

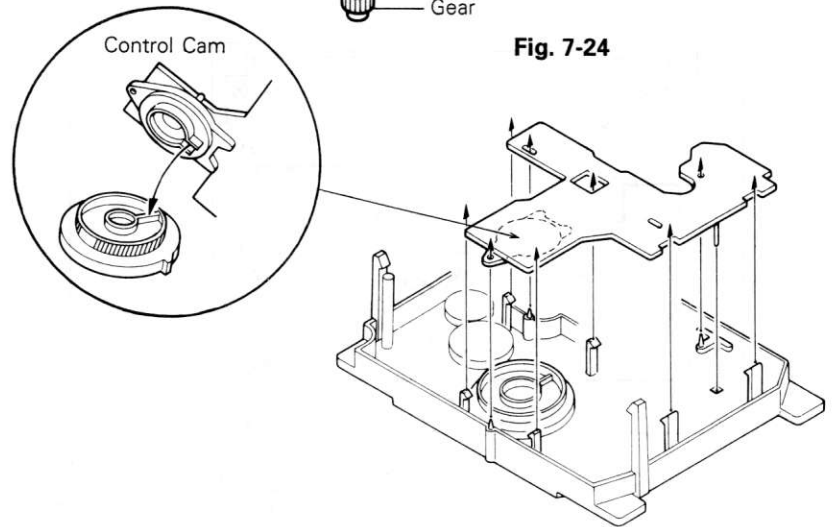

Fig. 7-25

■ **Cam switch board** (Fig. 7-21, Fig. 7-25)

1. Disengage six pawls retaining the cam switch board.
2. Engagement of the cam switch board with the control cam is shown in the magnified illustration in the circle.

■ **Actuator gear (big)** (Fig. 7-21, Fig. 7-26)

Disengage three pawls retaining the actuator gear (big).

■ **Control cam** (Fig. 7-21, Fig. 7-26)

1. Disengage two pawls retaining the control cam.
2. Assembled condition of the control cam is illustrated in the circle.

■ **Actuator gear (small)** (Fig. 7-21, 7-26)

Disengage two pawls retaining the actuator gear (small).

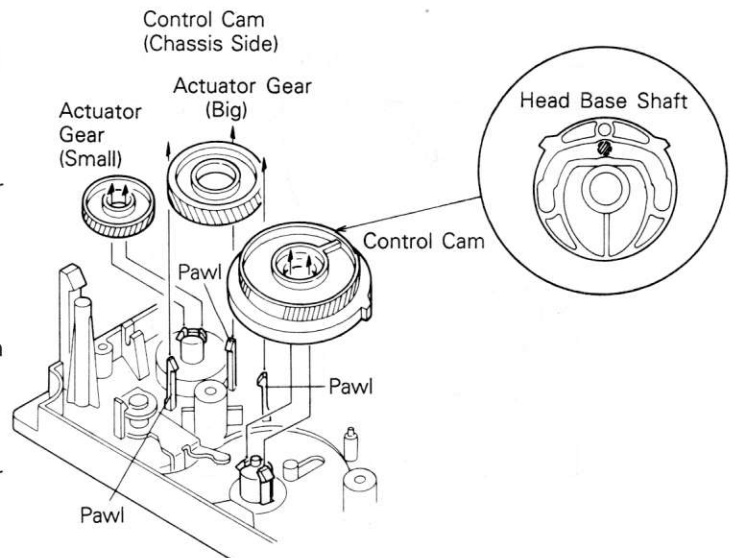

Fig. 7-26

■ Speaker system

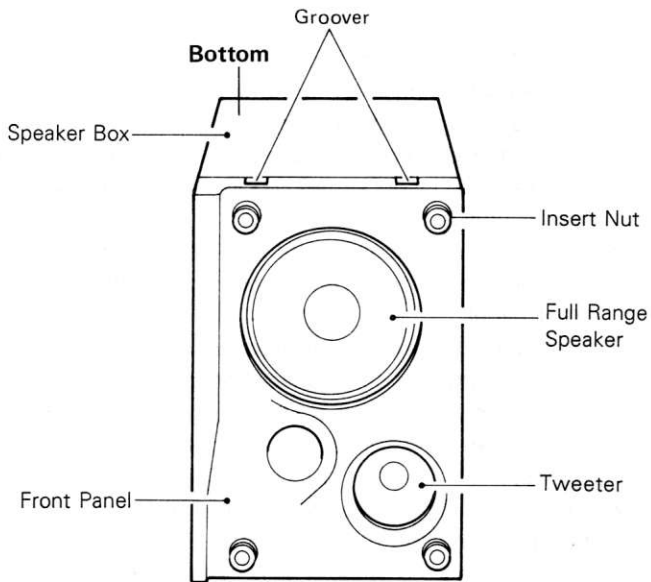

Fig. 7-28

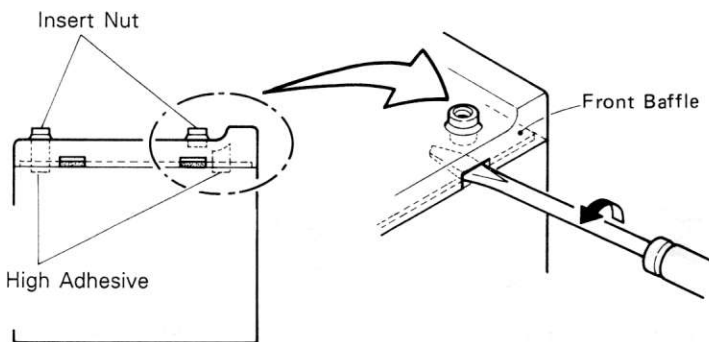

Fig. 7-29

Note : Front panel and speaker box are provided together with as an assembly for servicing. They won't be supplied individually.

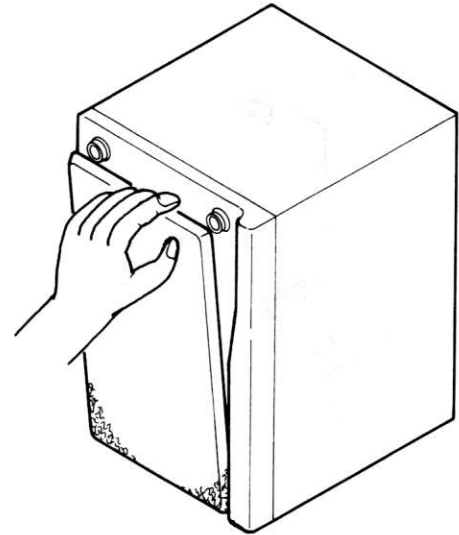

Fig. 7-27

■ Speaker box

1. Remove the Saran (synthetic resin) net by hand. (Fig. 7-27)
2. Stand the speaker box upside down as shown in Fig. 7-28.
3. Insert an ordinary (—) screwdriver into the right hole shown in Fig. 7-28 and Fig. 7-29 and push the bottom end of the insert nut upward.

Note: Since high power adhesive is used to glue the boss of the front panel and the speaker box together, apply a constant force for a long time to separate them from each other.

If it is intended to do in a short time, the boss of the front panel will be damaged.

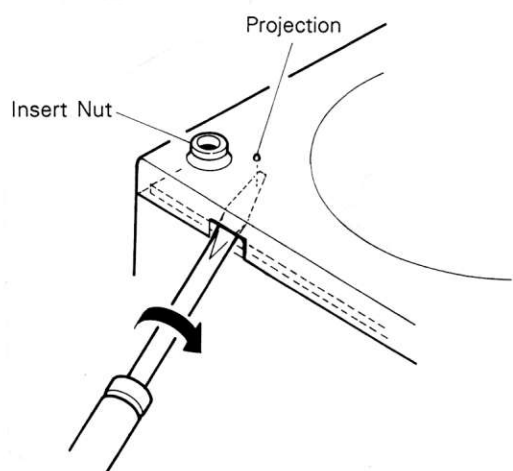

Fig. 7-30

4. Insert an ordinary (—) screwdriver into the left hole shown in Fig. 7-30 and set its edge just under the small projection. Keeping this position, slowly turn the screwdriver to push the front panel gently upward with care as described in the above note.
5. When there is a gap between the front panel and the speaker box, insert something like a UM-3 battery into it as shown in Fig. 7-31.
6. Next, insert an acrylic plate of 1 mm thick or so into the gap aiming at the center boss on the left side of the front panel.
7. In order to prevent the front panel from damage, insert an ordinary screwdriver between the front panel and the acrylic plate as shown in Fig. 7-31, then lift the front panel upward using the front baffle plate as a fulcrum.
8. Repeat the above steps 4 through 7 aiming at different bosses to remove the front panel.
9. For removing the speaker unit, remove four screws ① for the full range speaker while two screws ② for the tweeter as shown in Fig. 7-33.

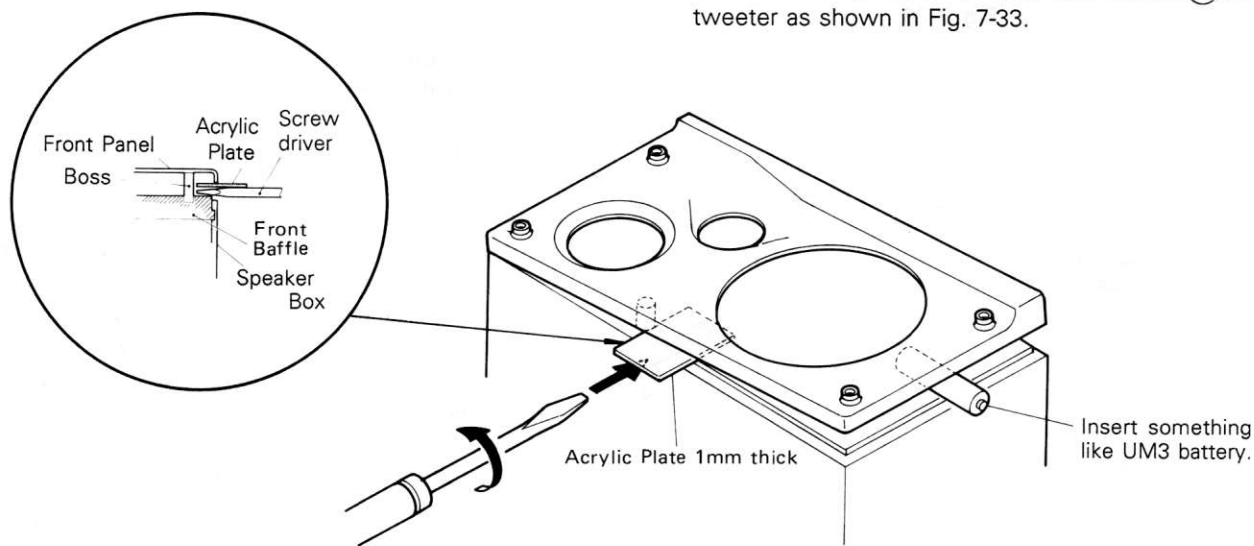

Fig. 7-31

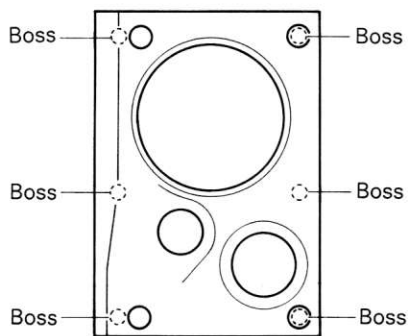

Fig. 7-32

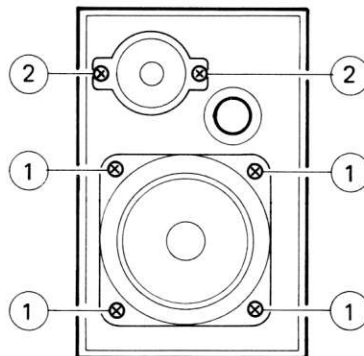

Fig. 7-33

8 Main Adjustment

Equipment and Measuring Instrument used for Adjustment

Electronic voltmeter
 Audio frequency oscillator
 Attenuator
 Wow-flutter meter
 Frequency counter

Standard signal generator
 Torque testing cassette gauge CTG-N
 Alignment tape
 Measuring tape: TS-8 (UR)
 VTT702 (8 kHz)

Condition for Measurement: Tuner Sections

Supply voltage : 230 V AC (50/60 Hz) . . . UX-1E/G
 240 V AC (50/60 Hz) . . . UX-1B

Applied voltage
 of the Tuner : 5.6 V DC
 Connect a 47 Ω resistor in series with the power supply.

Reference output: Speaker ; 50 mW (0.45 V)/4 Ω

Reference input: AUX IN ; -8 dBs

Headphone; 0.61 mW (0.14 V)/32 Ω

Input signal : (AM) Modulation frequency; 400 Hz, 30%
 (FM) Modulation frequency; 400 Hz,
 22.5 kHz dev.

Set position of

- Volume & Switch : BASS/TREBLE; Center
- FM; Stereo
- TIMER; OFF
- Main Volume; 0 dBs output
- BEAT Cut; Standard
- DOLBY NR; OFF
- TAPE SELECT; NORMAL

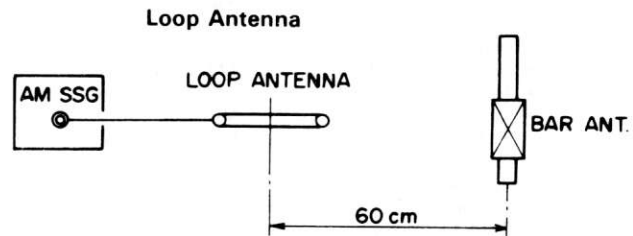

Fig. 8-1

Attentive point

Connection of IF sweeper :

Connect a 30 pF capacitor and a 33 kΩ resistor in series with the sweeper's output and a 0.082 μF capacitor and a 100 kΩ resistor in parallel to the input.

IF sweeper's output level: Set at the lowest level that will allow adjustment.

FM MPX adjustment:

For this adjustment, connect a 100 kΩ resistor in series with the frequency counter's input.

Location of Adjustment (Tuner P.C. Board View)

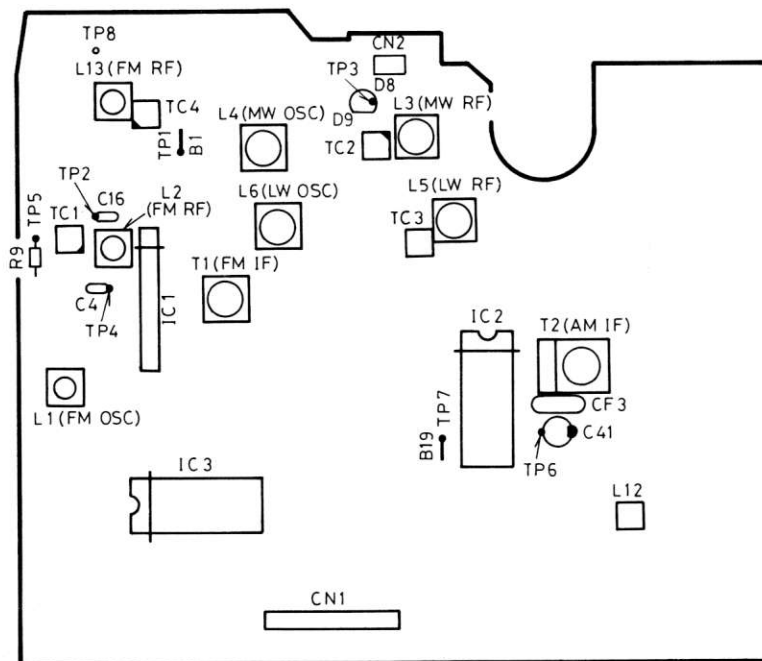

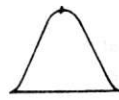

Fig. 8-2

- L5, L6 TC3 E/B/G Version only.
- L12, L13, TC4, TP8 G Version only.
- TC1 G Version only.

Preset memory (UX-1B/E/G)

Memory	Band	
	FM (MHz)	AM (kHz)
M1	87.5	522
M2	108	1629
M3	88	603
M4	98	1404
M5	106	999
M6	87.5	144
M7	87.5	288
M8	87.5	216

■ Adjustment of Tuner Section

Item	Measuring Condition and Main Adjustment	Standard Value	Adjust
AM IF	<p>The unit should not usually require adjustment. Follow the steps below when adjustment is necessary.</p> <p>[Conditions]</p> <ul style="list-style-type: none"> Band select switch position: AM Reception frequency: Set at the highest frequency where no signal is received. Volume control: Minimum gain position Tuner input position: Positive side to TP3 Tuner output position: Positive side to TP6, Negative side to TP7 <p>[Adjustment]</p> <p>Adjust T2 (above mentioned adjust point) so that maximum and symmetrical waveform can be obtained. In this case, the wave head should appear at the center marker (455 kHz) on the scope of sweeper.</p>	 <p>Fig. 8-3</p>	T2 (AM IF)
FM IF	<p>The unit should not usually require adjustment. Follow the steps below when adjustment is necessary.</p> <p>[Conditions]</p> <ul style="list-style-type: none"> Band select switch position: FM Reception frequency: Set at the highest frequency where no signal is received. Volume control: Minimum gain position Tuner input position: Positive side to TP4 Tuner output position: Positive side to TP6, Negative side to TP7 <p>[Adjustment]</p> <ol style="list-style-type: none"> Disconnect CF3 to change waveform from S-curve (Fig. 8-4) to single peak of the waveform (Fig. 8-5). Turn T1 to shape waveform so that it peaks in the center (10.7 MHz) of the waveform and is symmetrical in both sides. Connect CF3 again and confirm that waveform returns to the original (Fig. 8-4). 	 <p>Fig. 8-4</p>  <p>Fig. 8-5</p>	T1 (FM IF)
LW Tracking	<p>[Conditions]</p> <ul style="list-style-type: none"> Band select switch position: AM Tuner input: Loop antenna <p>[Adjustment]</p> <ol style="list-style-type: none"> Adjustment of VT: With preset to M6, receive 144 kHz signal and adjust L6 to obtain 1.1 ± 0.02 V at TP5. Frequency of SSG: 144 kHz Reception position: Preset position (M6) Adjust L5 to maximize output. Frequency of SSG: 288 kHz Reception position: Preset position (M7) Adjust TC3 to maximize output. Repeatedly adjust L5 and TC3 to obtain maximum sensitivity. 	1.1 ± 0.02 V Maximum Maximum	L5 TC3
MW Tracking	<p>[Conditions]</p> <ul style="list-style-type: none"> Band select switch position: AM Tuner input: Loop antenna <p>[Adjustment]</p> <p>The unit should not usually require adjustment. Follow the steps below when adjustment is necessary.</p> <ol style="list-style-type: none"> Frequency of SSG: 603 Hz Reception position: Preset position (M3) Adjust L3 to maximize output. Frequency of SSG: 1404 kHz Reception position: Preset position (M4) Adjust TC2 to maximize output. Repeatedly adjust L3 and TC2 to obtain maximum sensitivity. IFT adjustment (UX-1E #1-11000 only): Raise output up to 1404 kHz and adjust T2 to maximize output moreover. 	Maximum Maximum	L3 TC2
FM Tracking (UX-1E/B)	<p>[Conditions]</p> <ul style="list-style-type: none"> Band select switch position: FM Tuner input position: Positive side to TP1, Negative side to TP2 (75 Ω unbalanced) <p>[Adjustment - UX-1E/B]</p> <ol style="list-style-type: none"> Frequency of SSG: 88 MHz Reception position: Preset position (M3) Adjust L1 to maximize output. <p>[Adjustment - UX-1G]</p> <ol style="list-style-type: none"> Adjustment of VT: With preset to M4, receive 87.5 MHz signal and adjust L1 to obtain 1.3 ± 0.02 V at TP5. Frequency of SSG: 87.5 MHz Reception position: Preset position (M1) Frequency of SSG: 88 MHz Reception position: Preset position (M3) Adjust L2 and L13 to maximize output. Frequency of SSG: 106 MHz Reception position: Preset position (M4) Adjust TC1 and TC4 to maximize output. Repeatedly adjust L2 and TC1 to obtain maximum sensitivity. 	Maximum 1.3 ± 0.02 V Maximum Maximum	L1 L2, L13 TC1, TC4
FM MPX Confirmation	<p>[Conditions]</p> <ul style="list-style-type: none"> Input position: Positive side to TP1, Negative side to TP2, 75 Ω unbalanced Input signal: 98 MHz (preset position: M4), 60 dBμV modulation FM stereo modulation frequency: 1 kHz, 75 kHz dev. <p>[Confirmation]</p> <p>Confirm that stereo operation and frequency separation meet the specifications.</p>	-	-

■ Adjustment of Amplifier Section

Item	Test Tape	Measuring and Adjustment Method	Selector Switch	Adjusting Point
L, R channel output check	VTT752	Play side A of VTT752 test tape to check L-ch output. Play side B of VTT752 test tape to check R-ch output.	TAPE	—
PB frequency response check	VTT739 Adj. output at DOLBY test point	Play VTT739 test tape and check 1 kHz output at DOLBY test point against : 63 Hz $-2 \text{ dB} \pm \text{within } 4 \text{ dB}$ 12.5 kHz $0 \text{ dB} \pm 3 \text{ dB}$ (with setting to METAL position, deviation to NORMAL position should be as follows) 12.5 kHz within $-4 \pm 2 \text{ dB}$ Confirm the above relations.	TAPE	—
Auto tape select operation check	VTT739 Adj. output at DOLBY test point	Play VTT739 test tape without chrome detection tab cut off and check deviation of 12.5 kHz signal to 1 kHz signal.	TAPE	—
REC bias frequency adjustment	TS11 Adj. output at DOLBY test point	1) Set Beat Cut switch to NORMAL position. 2) With TAPE select switch set to METAL position, record on metal tape (TS-11). 3) Connect frequency counter to DOLBY test point and measure amplified bias leakage by divital voltmeter. 4) Adjust L301 so that frequency counter reads 69 kHz $\pm 0.1 \text{ kHz}$. 5) Set Beat Cut switch to position "2".	Beat Cut SW: NORMAL TAPE : Metal	L301
Head azimuth check	VTT704 (12.5 kHz) Adj. output at DOLBY test point	1) Play VTT704 test tape (12.5 kHz). 2) Confirm that there is not extreme difference in phase and level both in forward and reverse directions. 3) If difference is observed, adjust head azimuth adjusting screw for forward and reverse directions.	TAPE	Adjust head azimuth adjusting setscrew only after head replacement.
Tape speed & Wow & flutter adj. & check	VTT712 (3 kHz) Adj. output at DOLBY test point	1) Play VTT712 test tape (3 kHz) on mechanism B in the forward direction, and adjust VR501 so that frequency counter reads in a range between 2940 and 3090 Hz. 2) Play VTT712 test tape (3 kHz) in the reverse direction, and confirm that frequency counter reads 3000 $\pm 60 \text{ Hz}$. 3) Wow & flutter : Less than 0.2 % (JIS WRMS).	TAPE	VR501
PB output level adj.	VTT724 (1 kHz) Adj. output at DOLBY test point	Play VTT724 test tape and adjust the following so that output level is -11 dB s at DOLBY test point. VR101 for L-ch, VR201 for R-ch	TAPE	VR101 (L-ch) VR201 (R-ch)
REC/PB frequency response adj. & check	TS8, TS10 Adj. output at DOLBY test point	1) Input reference -20 dB signal through AUX IN and record it on normal tape TS8. Playing back the tape, adjust VRB11 (L-ch) and VRB21 (R-ch) respectively so that deviation of 1.25 kHz to 12.5 kHz is $0 \pm 1 \text{ dB}$ at DOLBY test point. 2) In the same manner, record the signal on CrO ₂ (TS10) tape and metal (TS11) tape and play them back to confirm that deviation of 1.25 kHz to 12.5 kHz is $1 \pm 4 \text{ dB}$.	TAPE: NORMAL TAPE: CrO ₂ , METAL	VRB11 (L-ch) VRB21 (R-ch)
REC/PB output level adj.	TS8, TS10, TS11 Adj. output at DOLBY test point	1) Input reference 1 kHz signal through AUX IN and record the signal on normal tape (TS8). 2) Play back the recording and adjust VR102 (L-ch) and VR202 (R-ch) respectively to obtain $0 \pm 0.5 \text{ dB}$ as output level at DOLBY test point. 3) In the same manner, record the signal on chrome tape (TS10) and metal tape (TS11). 4) Play them back to confirm that output level at DOLBY test point is $0 \pm 3 \text{ dB}$.	TAPE: NORMAL TAPE: CrO ₂ , METAL	VR102 (L-ch) VR202 (R-ch)

■ Location of Adjustments : Tape Deck Amplifier Section

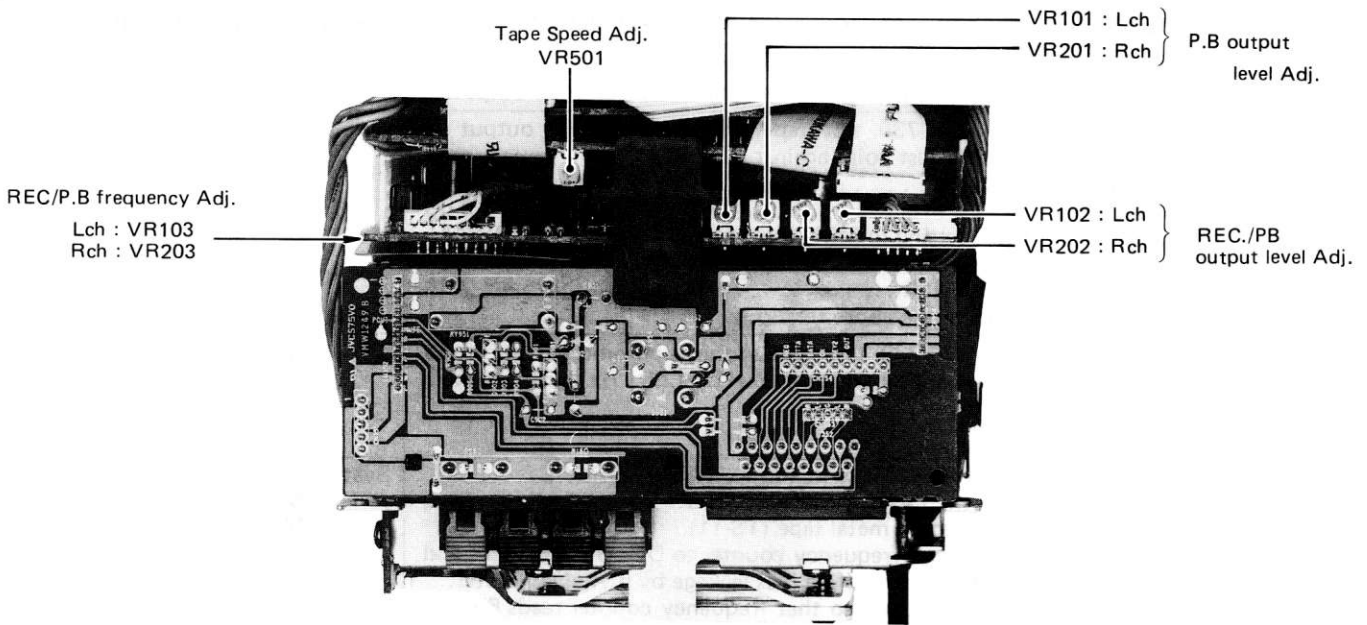

Fig. 8-6

■ Adjustment of CD Player Sections

CD unit

The term "in this State" refers to the state in which the CD mechanism (EXL-M5C) and CD Control Board (VMW2307A) are assembled. Accordingly, maintenance and other service operations are performed in a "State of CD Unit".

How to Reset Microcomputer

Adjust level at pin ⑥ of FW2 to +5 V first, and then shortcircuit it to GND.

• Preparation

1. When regulated power supply is used, shortcircuit between pin ① and pin ④ of FW501.
Supply power of 10 V to pin ② of FW501.
Measure audio output at the speaker output terminal.
2. When adjustment or measurement needs to load a disk, remove the magnet clamber from the set.
3. With the OPEN/CLOSE switch (leaf switches S718, S717) set to ON, TOC reading starts.

■ Adjustment of Tracking Offset

Oscilloscope, Normal disk are necessary.

• Adjustment procedure

1. Connect an oscilloscope between TP502 (VREF) and TP503 (TE).
2. Play a normal disk.
3. Shortcircuit between TP504 and TP502.
4. Adjust VR501 so that DC level of tracking error signal becomes zero (waveform on oscilloscope screen).

Note: Adjust VR501 to shape waveform vertically symmetric based on zero level.
Input to oscilloscope is supplied in DC coupling circuit.

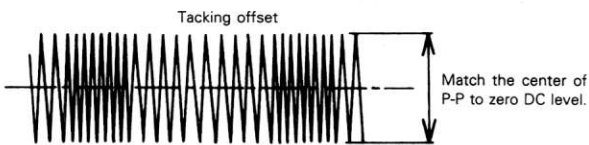

Fig. 8-7

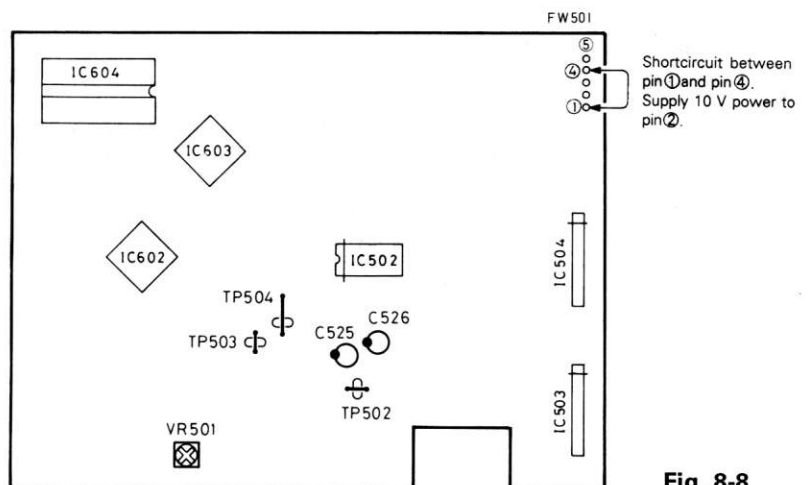

Fig. 8-8

■ Standard Specification of Mechanism

No.	Item	Condition	Standard Value			Measuring Instrument and Tape
1	Take-up torque (g-cm)	PLAY FF/REW (FWD REV)	27~60 g-cm 90~200 g-cm			Cassette torque gauge TW2111A (for FWD) TW2121A (for REV) TW2232 (for FF/REW)
2	*Speed diviation (Hz)	Tape start, end	4.8 cm/sec 2940~3060 Hz 9.6 cm/sec 5880~6120 Hz	*Speed error Difference between tape FWD speed at the beginning of tape on mechanism B and tape REV speed at the beginning of tape on mechanism A must be within 40Hz.	Speed must be adjusted at: 3000±10 Hz 6000±20 Hz	VTT712 Wow-flutter meter
3	Wow-flutter (%)	Tape start, end (FWD, REV)	JIS WRMS less than 0.18% JIS RMS less than 0.33%			VTT712 Wow-flutter meter
4	Pinch roller press power (g)	Play back (FWD, REV)	260~340 g			Leaf gauge
5	Back tension on the reel (g-cm)	Play back (FWD, REV)	1.5~5.0 g-cm			Cassette torque gauge TW2111A (for FWD) TW2121A (for REV)
6	Fast FWD time (SEC)	FF, REW	Less than 120 sec			C-60 tape
7	Tape tension (g-cm)	Play back (FWD, REV)	More than 90 g-cm			Cassette torque gauge TW2412 (for FWD) TW2422 (for REV)
8	Current consumption (mA)	CAP PLAY REEL ACT FF/REW REEL	Less than 100 mA Less than 70 mA Less than 180 mA Less than 70 mA			C-60 tape Ammeter
9	12.5 kHz azimuth (dB)	Difference between: FWD and REV Lch and Rch	Less than 3 dB Less than 4 dB			HEAD amplifier Electrical voltmeter VTT704(12.5 kHz)
10	E HEAD tilt check	FWD REV	90° ± 45'			M300 gauge 45' chip

9 Block Diagram

■ CD Player Sections

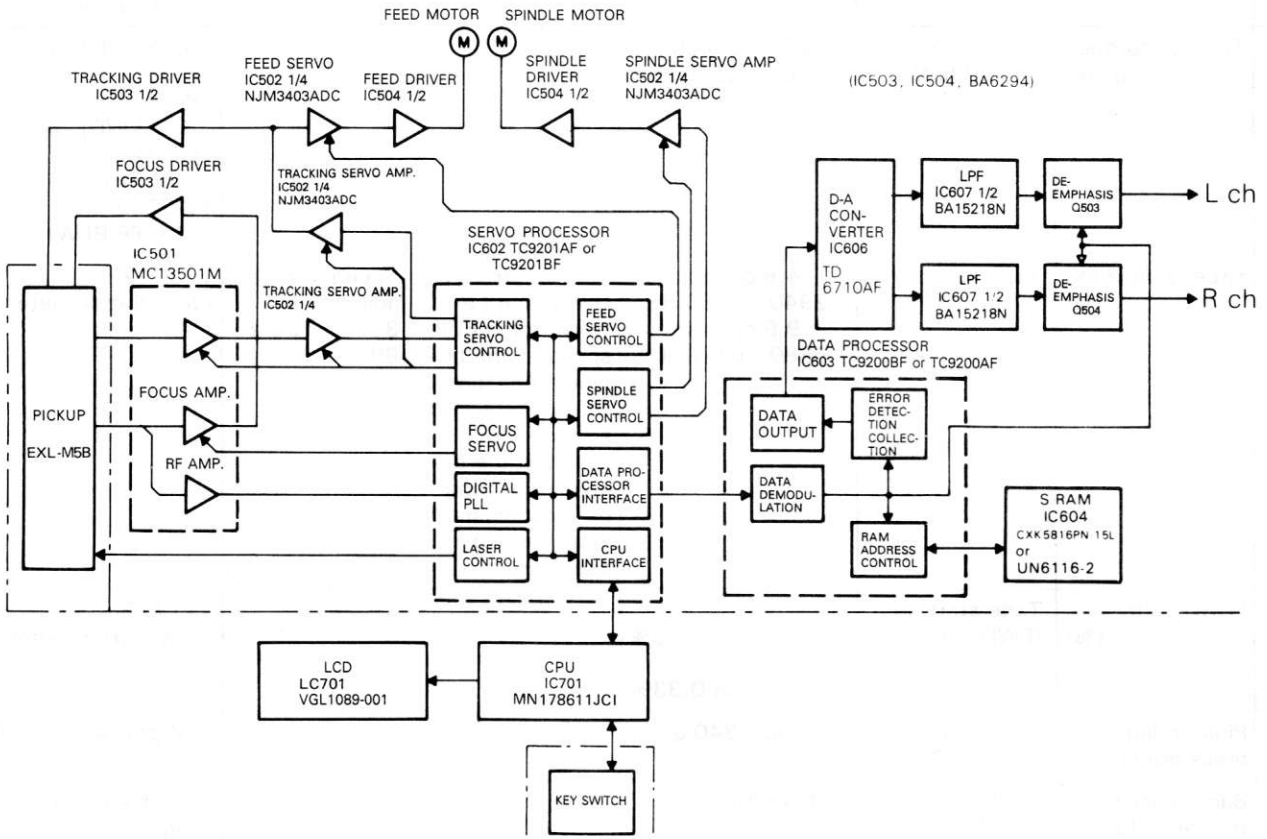

Fig. 9-1

■ General Sections

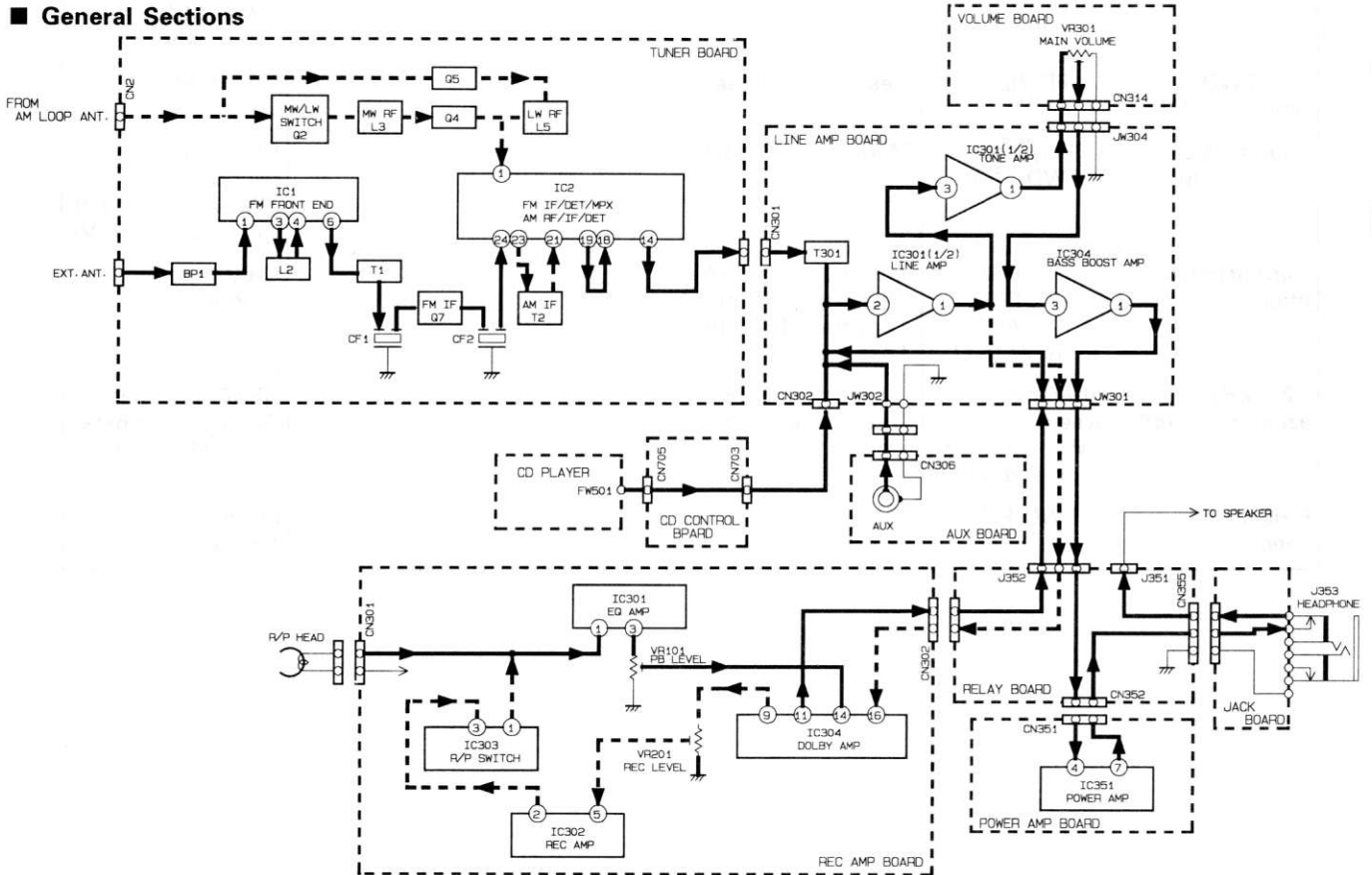

Fig. 9-2

■ Tape Deck. Amplifier Section

Color codes are shown below.

- 1 Brown
- 2 Red
- 3 Orange
- 4 Yellow
- 5 Green
- 6 Blue
- 7 Violet
- 8 Grey
- 9 White
- 0 Black

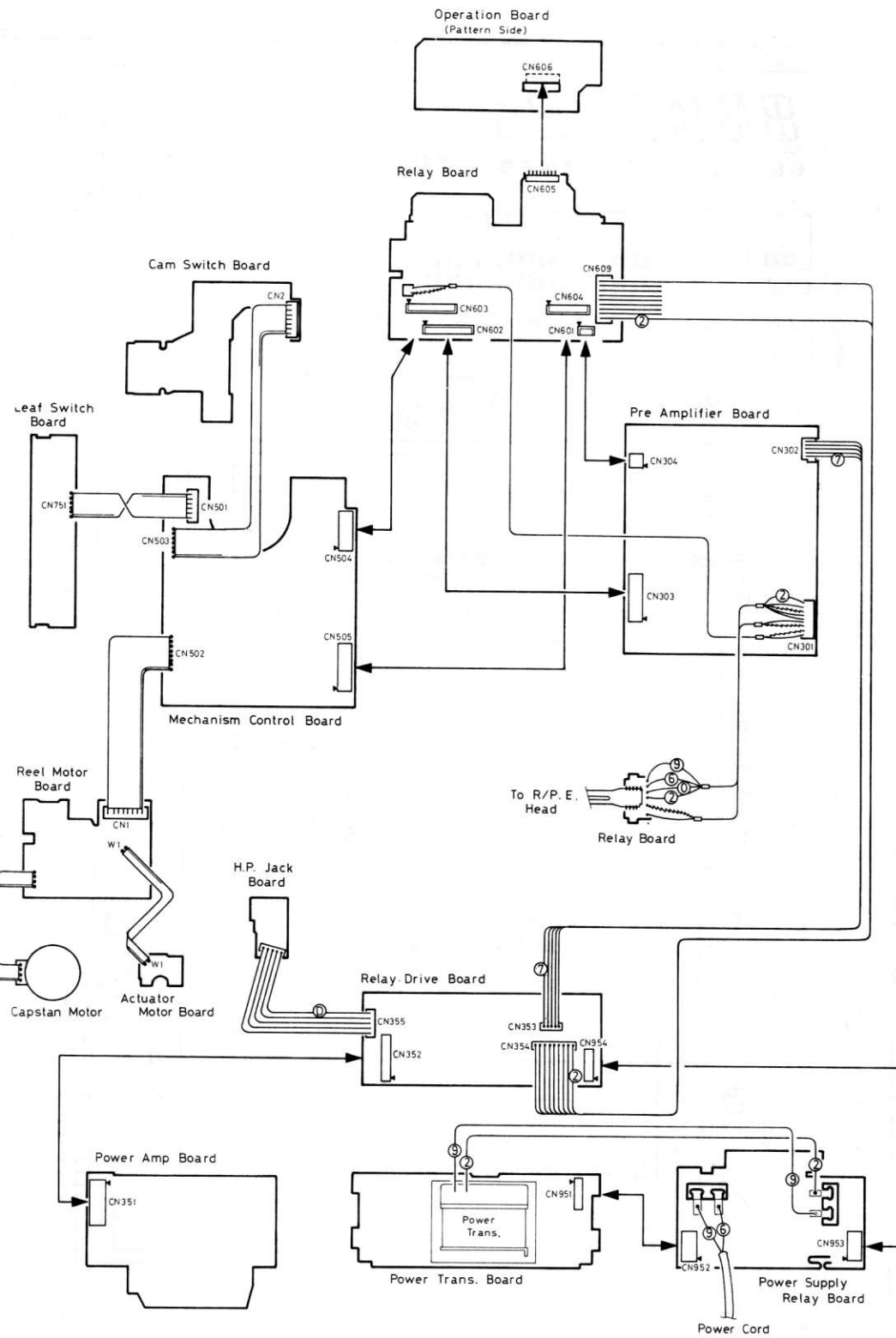

Fig. 10-2

P.C. Board Parts

6

7

8

9

10

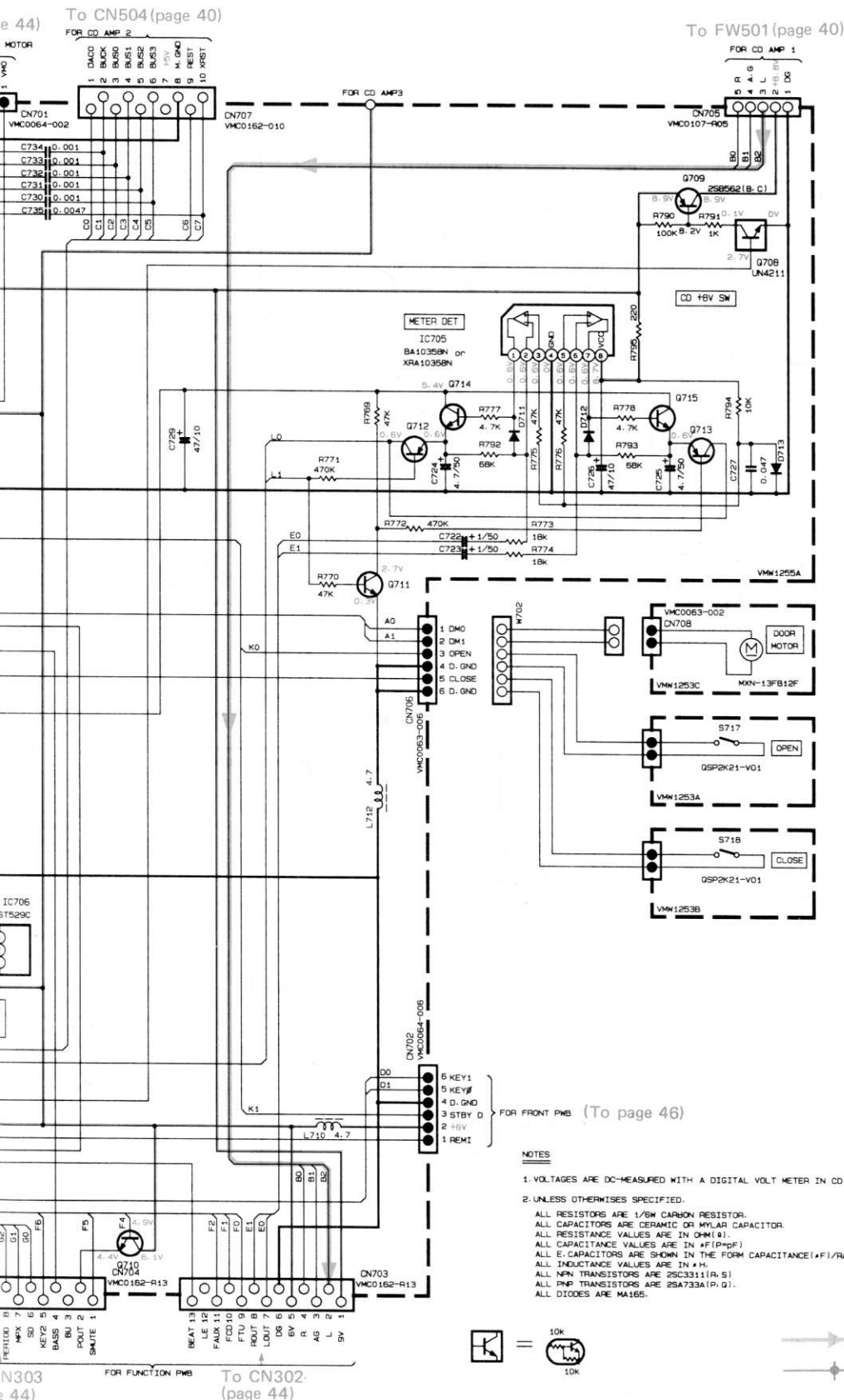

- NOTES**
1. VOLTAGES ARE DC-MEASURED WITH A DIGITAL VOLT METER IN CD STOP.
 2. UNLESS OTHERWISE SPECIFIED, ALL RESISTORS ARE 1/8W CARBON RESISTOR. ALL CAPACITORS ARE CERAMIC OR MYLAR CAPACITOR. ALL RESISTANCE VALUES ARE IN OHM (Ω). ALL CAPACITANCE VALUES ARE IN μF (P+P). ALL E. CAPACITORS ARE SHOWN IN THE FORM CAPACITANCE(μF)/RATED VOLTAGE(V). ALL INDUCTANCE VALUES ARE IN μH. ALL NPN TRANSISTORS ARE 2SC3311(R, S). ALL PNP TRANSISTORS ARE 2SA733A(P, G). ALL DIODES ARE MA165.

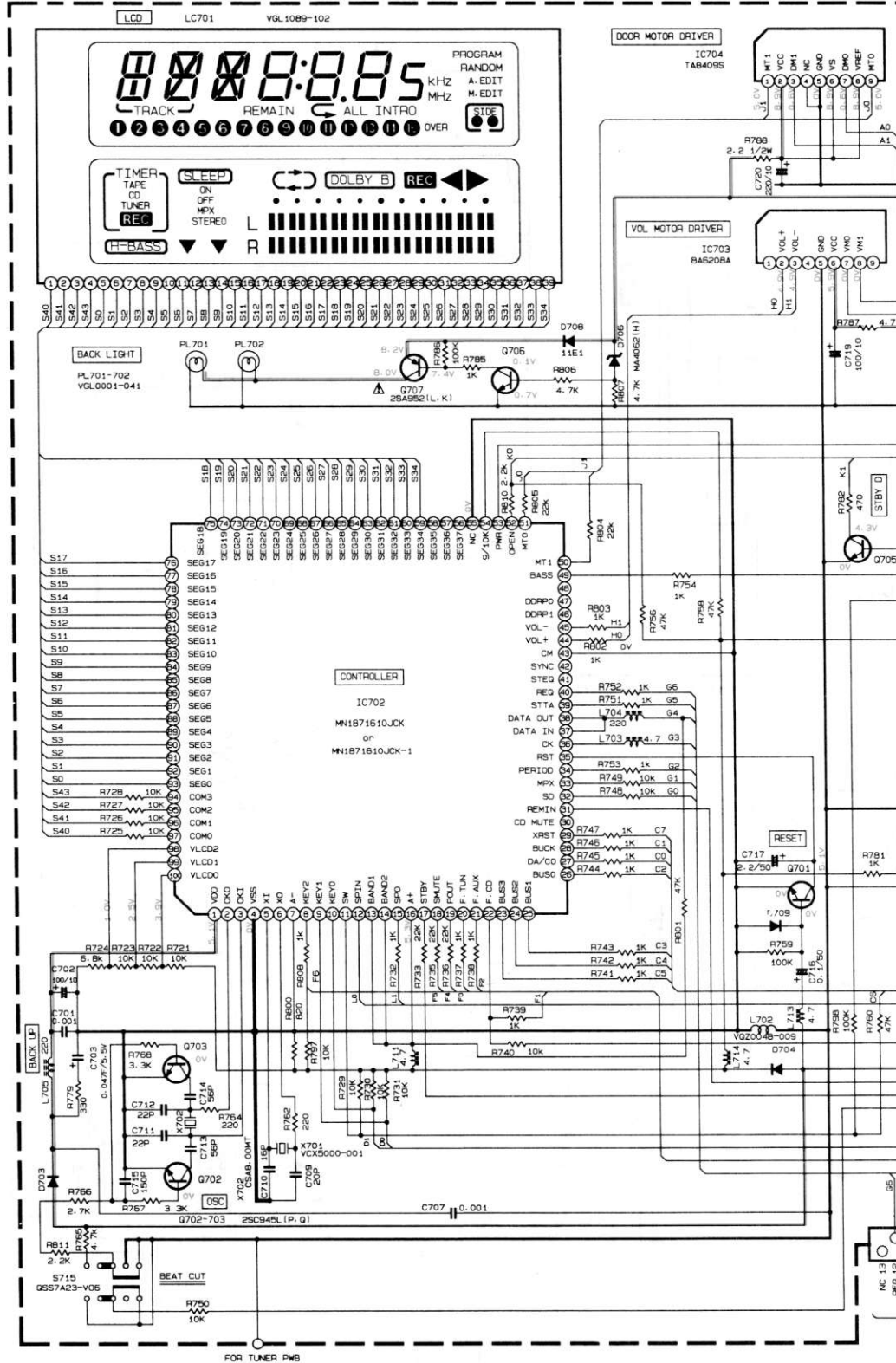

Fig. 11-1
38 (No. 1822)

11 Standard Schematic Diagram and Location of

Microcomputer, LCD Display Section : Drawing No. VDH9159-005SV/UX-1B/E/G/GE/GZ

A
B
C
D
E
F
G



FOR TUNER PWB

1

2

3

4

5

A

B

C

D

E

F

G

Microcomputer, LCD Display P.C. Board : Drawing No. VMW1255A

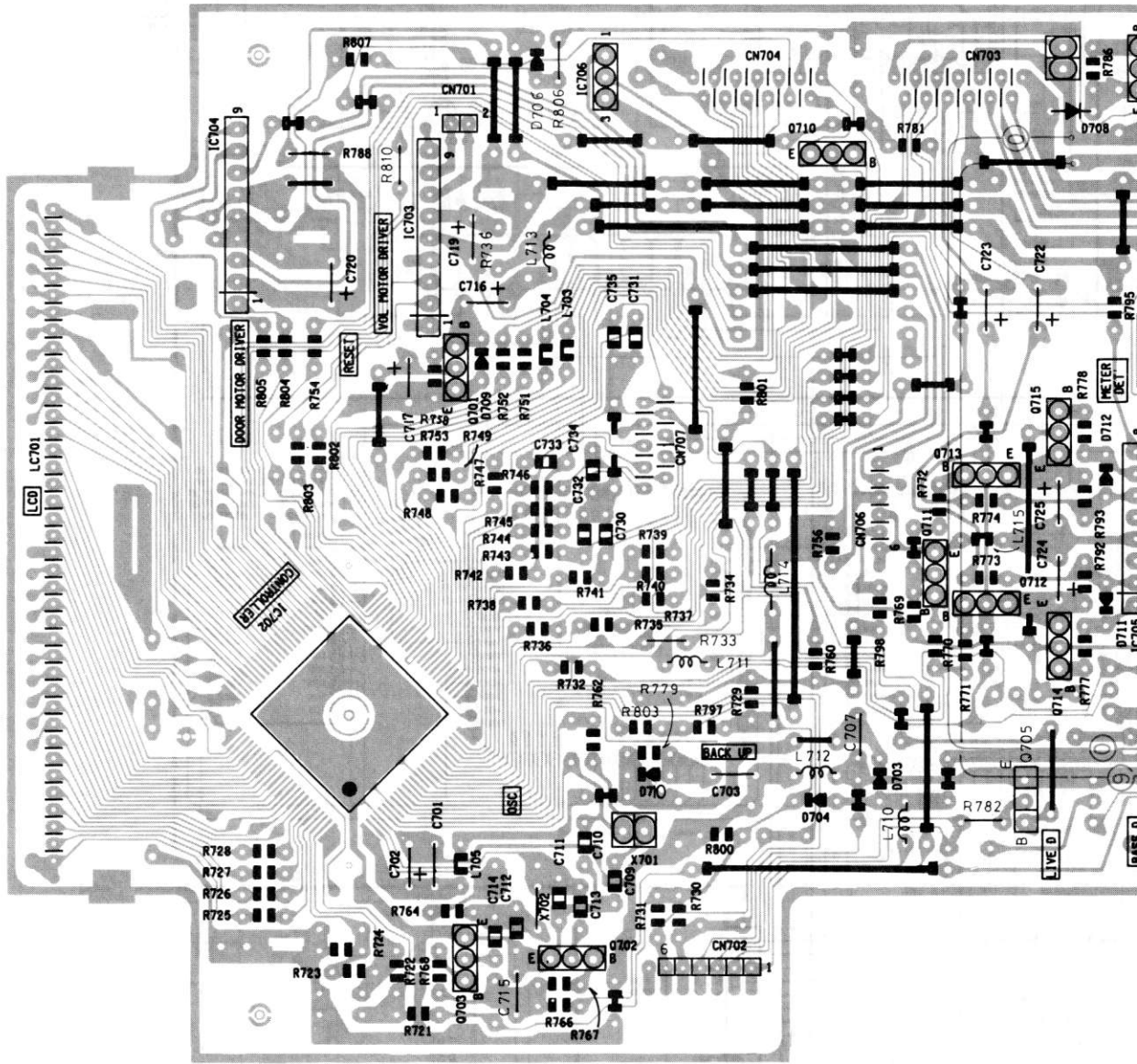
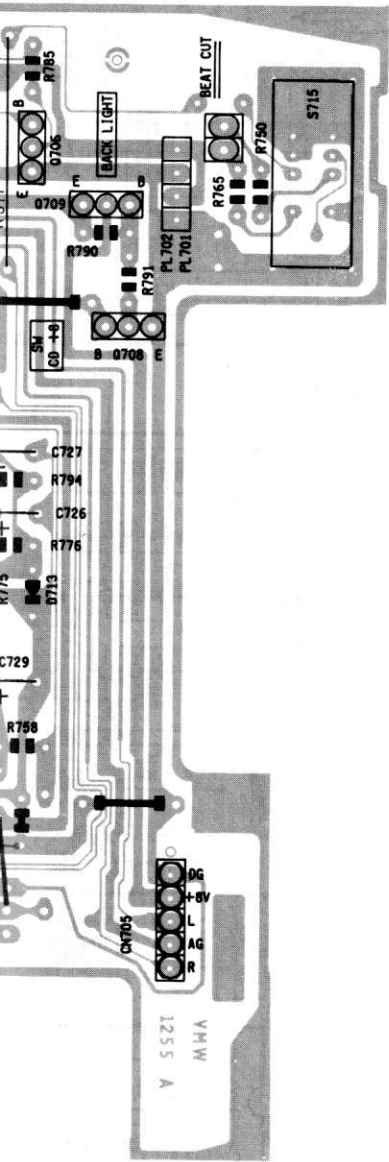

Fig. 11-2



■ Door Close Switch P.C. Board :
Drawing No. VMW1253A

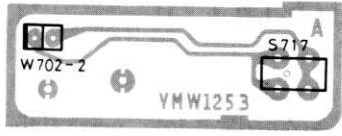

Fig. 11-3

■ CD Door Open Switch P.C. Board :
Drawing No. VMW1253B

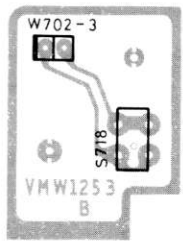

Fig. 11-4

■ CD Door Motor P.C. Board :
Drawing No. VMW1253C

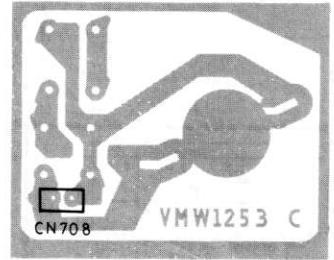

Fig. 11-5

■ Jack P.C. Board :
Drawing No. VMW1253E

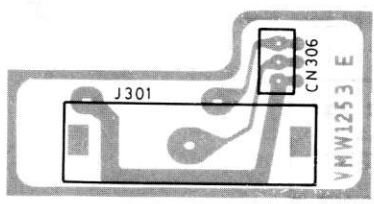
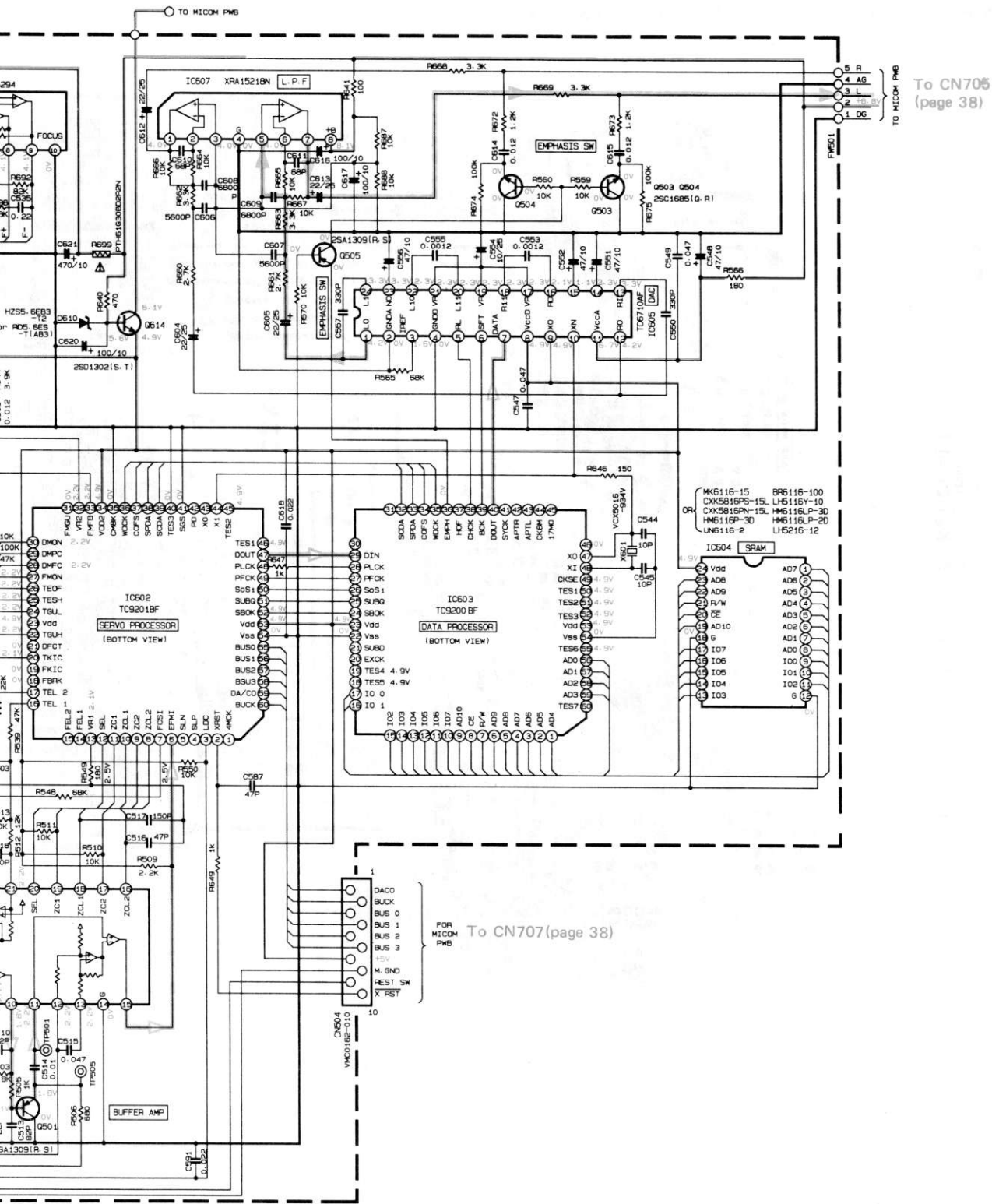

Fig. 11-6



To CN705 (page 38)

FOR MICOM PWB To CN707 (page 38)

VOL TAGE (V)
5-697)

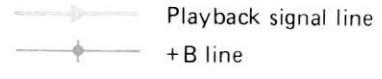
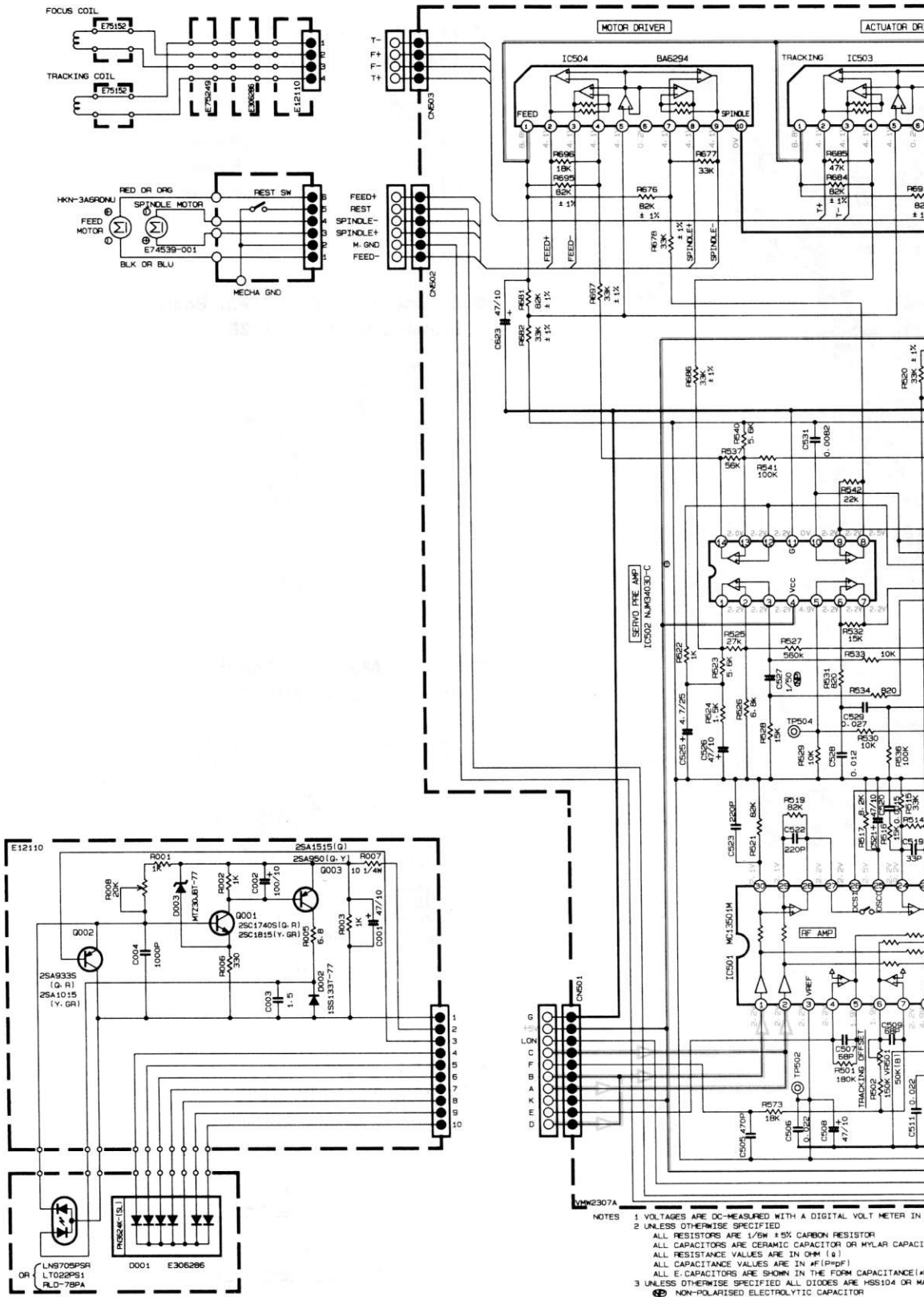

Fig. 11-7
40 (No. 1822)

■ CD Control Section : Drawing No. VDH9159-005CV/UX-1B/E/G/GE/GI

A
B
C
D
E
F
G



- NOTES
- 1 VOLTAGES ARE DC-MEASURED WITH A DIGITAL VOLT METER IN S...
 - 2 UNLESS OTHERWISE SPECIFIED
 - ALL RESISTORS ARE 1/8W ± 5% CARBON RESISTOR
 - ALL CAPACITORS ARE CERAMIC CAPACITOR OR MYLAR CAPACIT...
 - ALL RESISTANCE VALUES ARE IN OHM (Ω)
 - ALL CAPACITANCE VALUES ARE IN μF (μF)
 - ALL E-CAPACITORS ARE SHOWN IN THE FORM CAPACITANCE/UF
 - 3 UNLESS OTHERWISE SPECIFIED ALL DIODES ARE HSS104 OR MA...
 - ⊕ NON-POLARISED ELECTROLYTIC CAPACITOR
 - * 1/4W ± 1% CARBON RESISTOR (R520, 576, 578, 581, 582, 584, 586...

■ CD Control P.C. Board : Drawing No. VMW2307/UX-1E

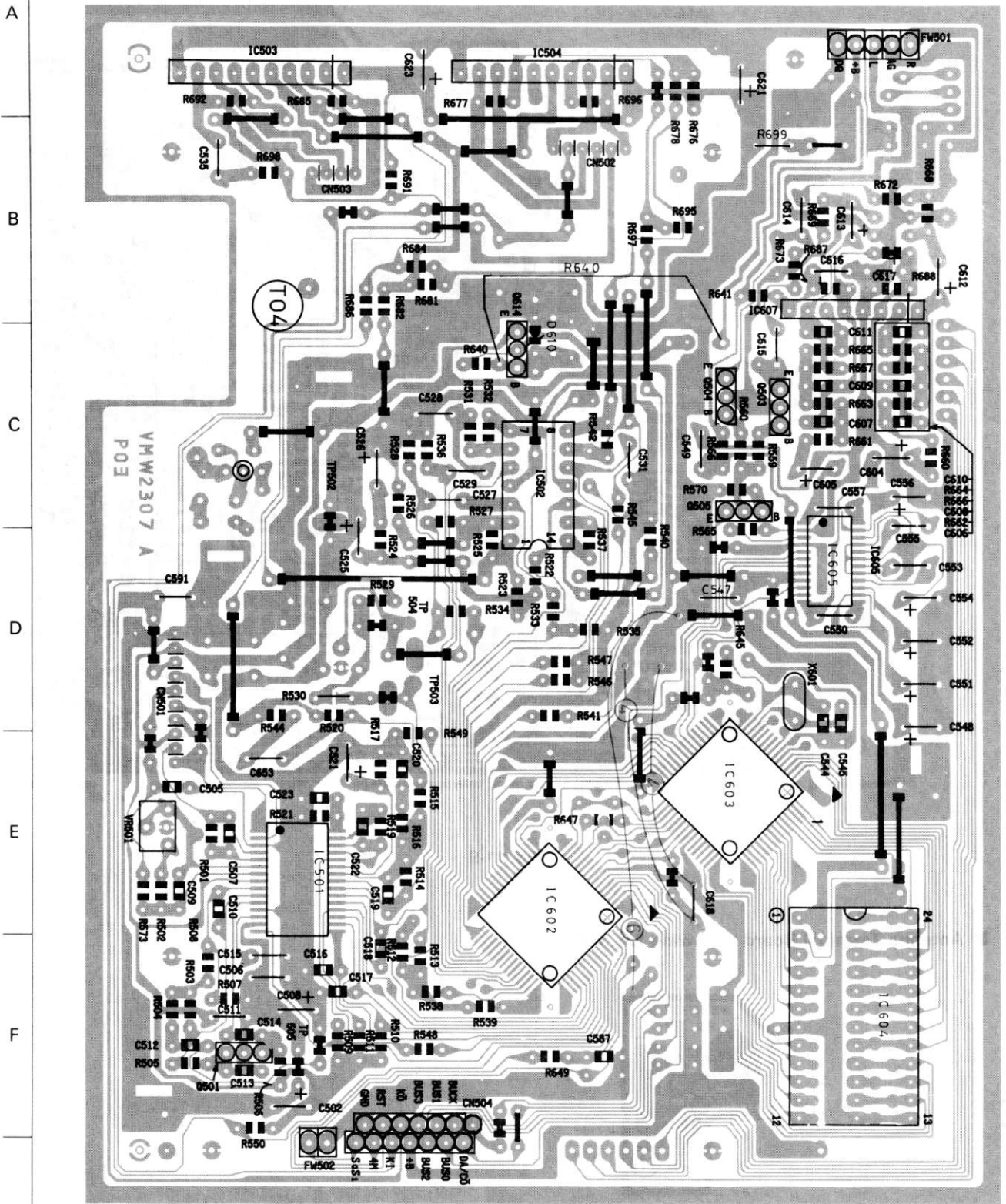

Fig. 11-8

1 2 3 4 5

■ Tuner P.C. Board : Drawing No. VMW2326/UX-1B/E

A
B
C
D
E
F
G

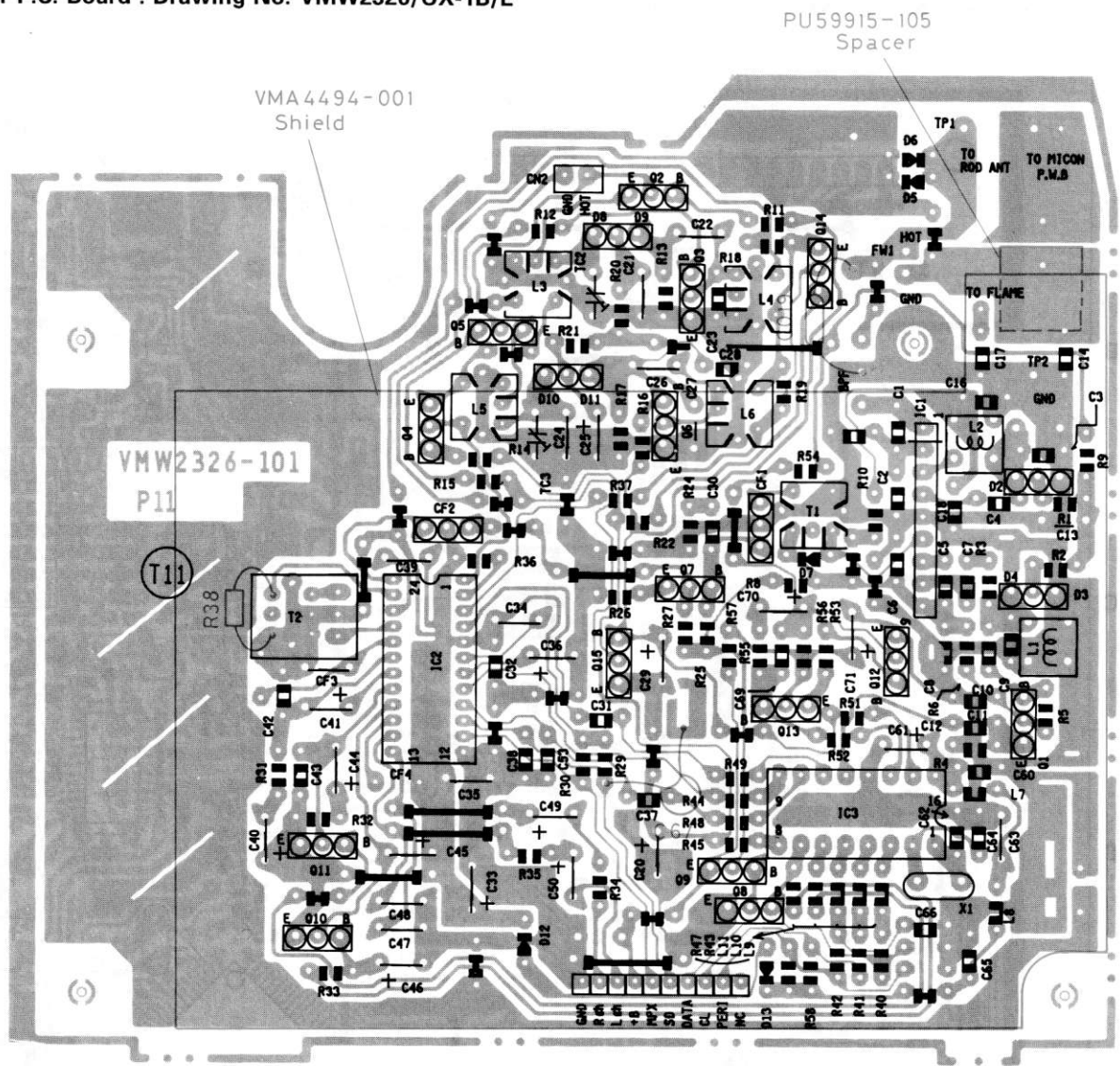

Fig. 11-9

■ Antenna Terminal Board : Drawing No. VMW2339A

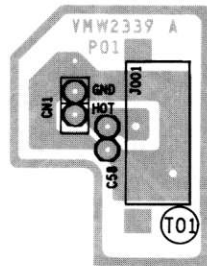

Fig. 11-10

1 2 3 4 5

■ Tuner Section : Drawing No. VDH9159-005TW/UX-1B/E

A

B

C

D

E

F

G

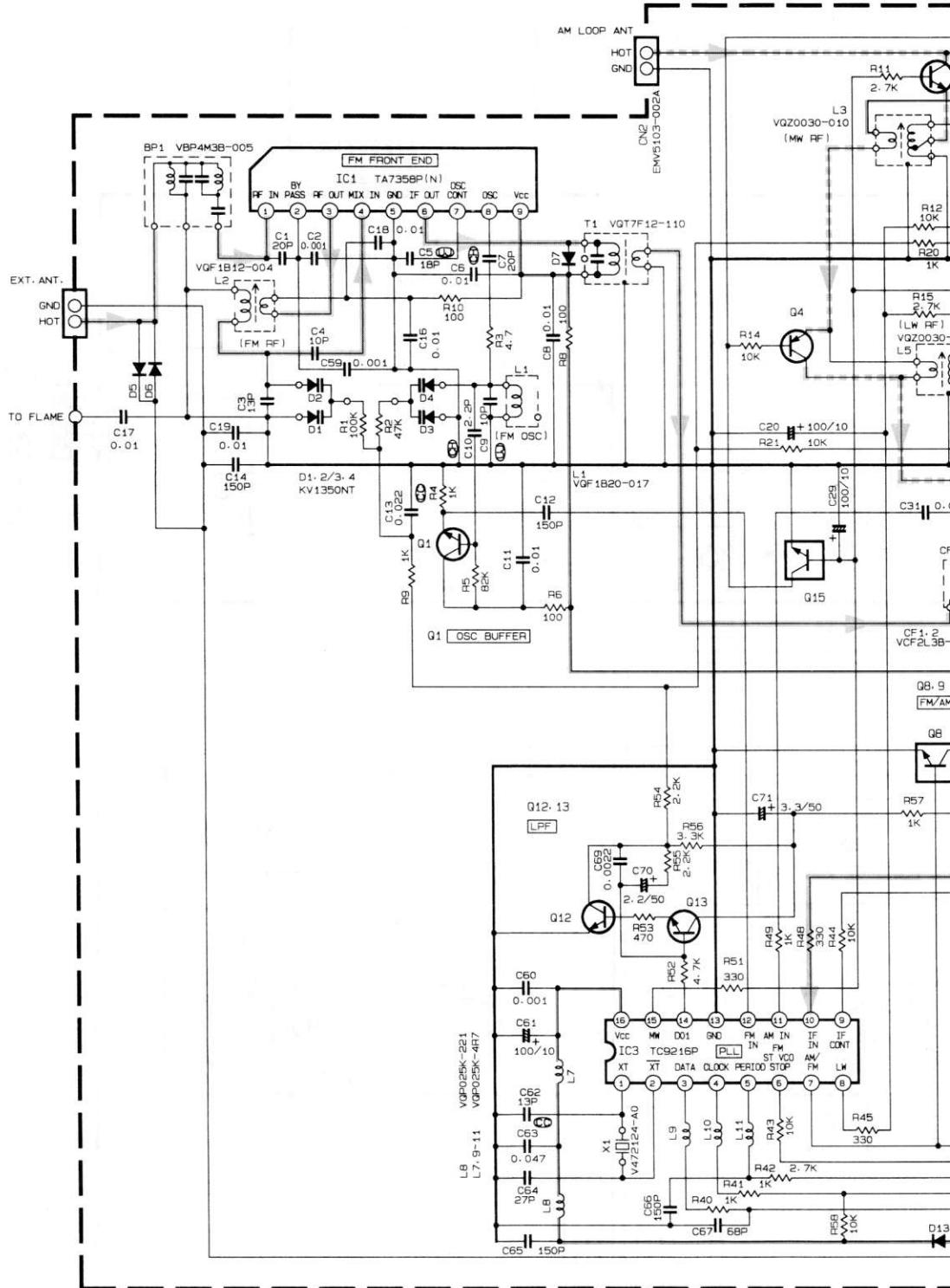

NOTES

- VOLTAGES ARE DC-MEASURED WITH A DIGITAL VOLT METER.
- ALL RESISTORS ARE 1/6W ±5% CARBON RESISTOR.
- ALL RESISTANCE VALUES ARE IN OHM (Ω).
- ALL CAPACITANCE VALUES ARE IN pF (pPF).
- ALL CAPACITORS ARE SHOWN IN THE FORM OF CAPACITANCE (pF)/RATED VOLTAGE (V)
- SI DIODES (▶) ARE ALL MA165 THAT CAN BE CHANGED TO SIMILAR DIODE SUCH AS 1SS254T OR HSS104TJ.
- PARTS NO. OF TRANSISTOR ARE AS FOLLOWS.

Q1	2SC1923(D)	Q4, 14	2SA1309(R, S)
Q6, 8, 12, 13	2SC3311(R, S)	Q9-11	DTA114YS
Q3, 7	2SC2839(E)	Q2, 5	2SD1302(S, T)
Q8	DTC114YN	Q15	DTC124ES

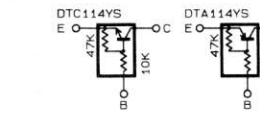

B. INSIDE OF DIGITAL TRANSISTORS

6

7

8

9

10

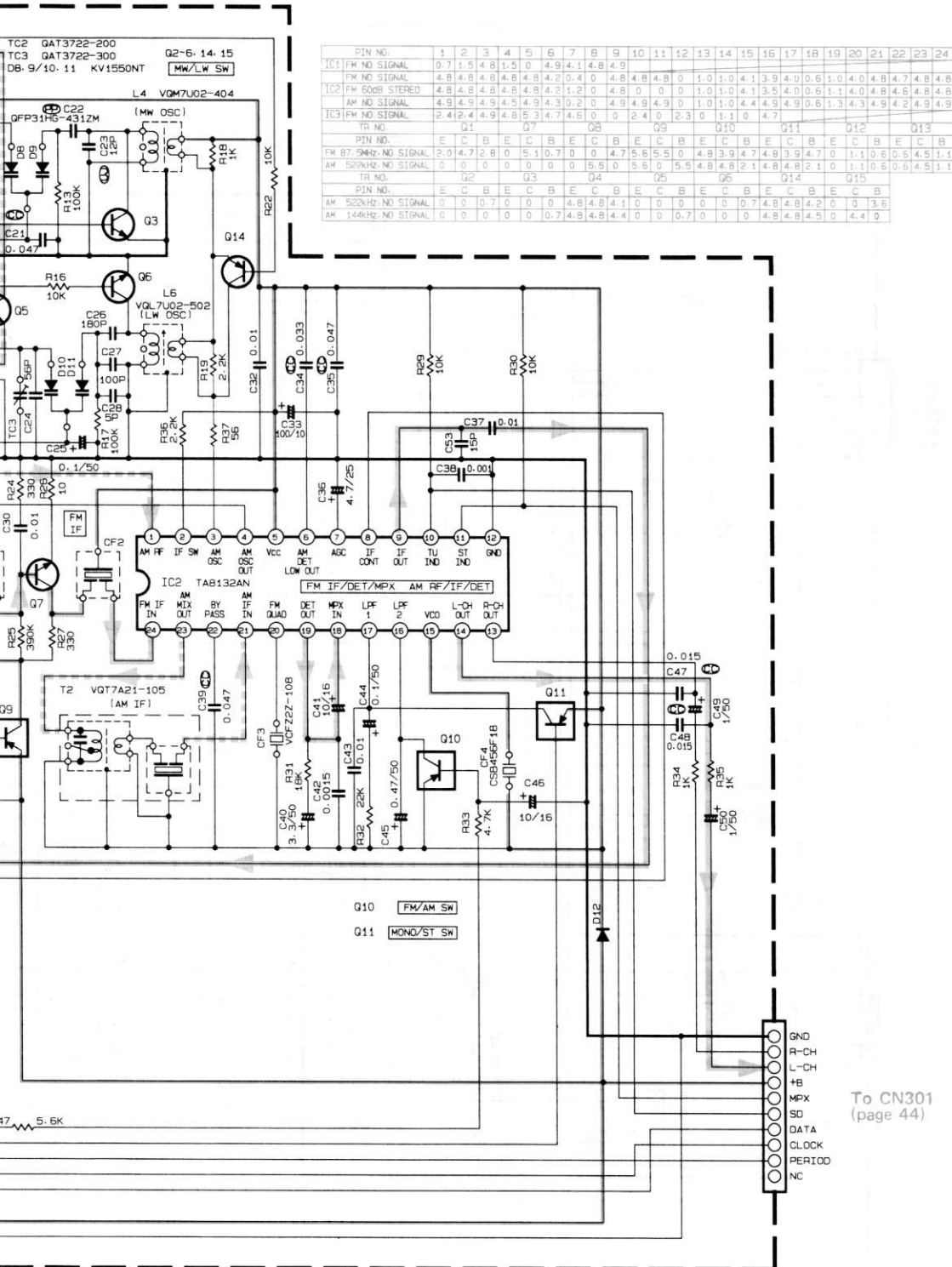

PIN NO.	1	2	3	4	5	6	7	8	9	10	11	12	13	14	15	16	17	18	19	20	21	22	23	24
IC1 FM NO SIGNAL	0.7	1.5	4.8	1.5	0	4.9	4.1	4.8	4.9															
IC2 FM NO SIGNAL	4.8	4.8	4.8	4.8	4.8	4.2	0.4	0	4.8	4.8	4.8	0	1.0	1.0	4.1	3.9	4.0	0.6	1.0	4.0	4.8	4.7	4.8	4.8
IC2 FM 50dB STEREO	4.8	4.8	4.8	4.8	4.2	1.2	0	4.8	0	0	0	1.0	1.0	4.1	3.5	4.0	0.6	1.1	4.0	4.8	4.6	4.8	4.8	4.8
IC2 AM NO SIGNAL	4.9	4.9	4.9	4.9	4.3	0.2	0	4.9	4.9	0	1.0	1.0	4.4	4.9	4.9	0.6	1.3	4.3	4.9	4.2	4.9	4.2	4.9	4.9
IC3 FM NO SIGNAL	2.4	2.4	4.8	5.3	4.7	4.6	0	2.4	0	2.3	0	1.1	0	4.7										
TR NO.	Q1			Q7			Q8			Q9			Q10			Q11			Q12			Q13		
PIN NO.	E	C	B	E	C	B	E	C	B	E	C	B	E	C	B	E	C	B	E	C	B	E	C	B
FM 87.5MHz: NO SIGNAL	2.0	4.7	2.8	0	5.1	0.7	0	4.7	5.6	5.5	0	4.8	3.9	4.7	4.8	3.9	4.7	0	1.1	0.6	0.6	4.5	1.1	
AM 520kHz: NO SIGNAL	0	0	0	0	0	0	0	5.5	0	5.5	4.8	4.8	2.1	4.8	4.8	2.1	0	1.1	0.6	0.6	4.5	1.1		
TR NO.	Q2			Q3			Q4			Q5			Q6			Q14			Q15					
PIN NO.	E	C	B	E	C	B	E	C	B	E	C	B	E	C	B	E	C	B	E	C	B	E	C	B
AM 520kHz: NO SIGNAL	0	0	0.7	0	0	0	4.8	4.8	4.1	0	0	0	0	0.7	4.8	4.8	4.2	0	0	3.6				
AM 144kHz: NO SIGNAL	0	0	0	0	0	0.7	4.8	4.8	4.4	0	0	0.7	0	0	4.8	4.8	4.5	0	4.4	0				

SHOWN AS FOLLOWS:

9: LAST NO.
 R 58 C 71 Q 15 D 13
 BLANK NO.
 R 7, 23, 28, 38, 39, 46, 50
 C 15, 51, 52, 54, 58, 68

Fig. 11-11

Playback signal line
 +B line

Function Section : Drawing No. VDH9159-006BV/UX-1E/B

A
B
C
D
E
F
G

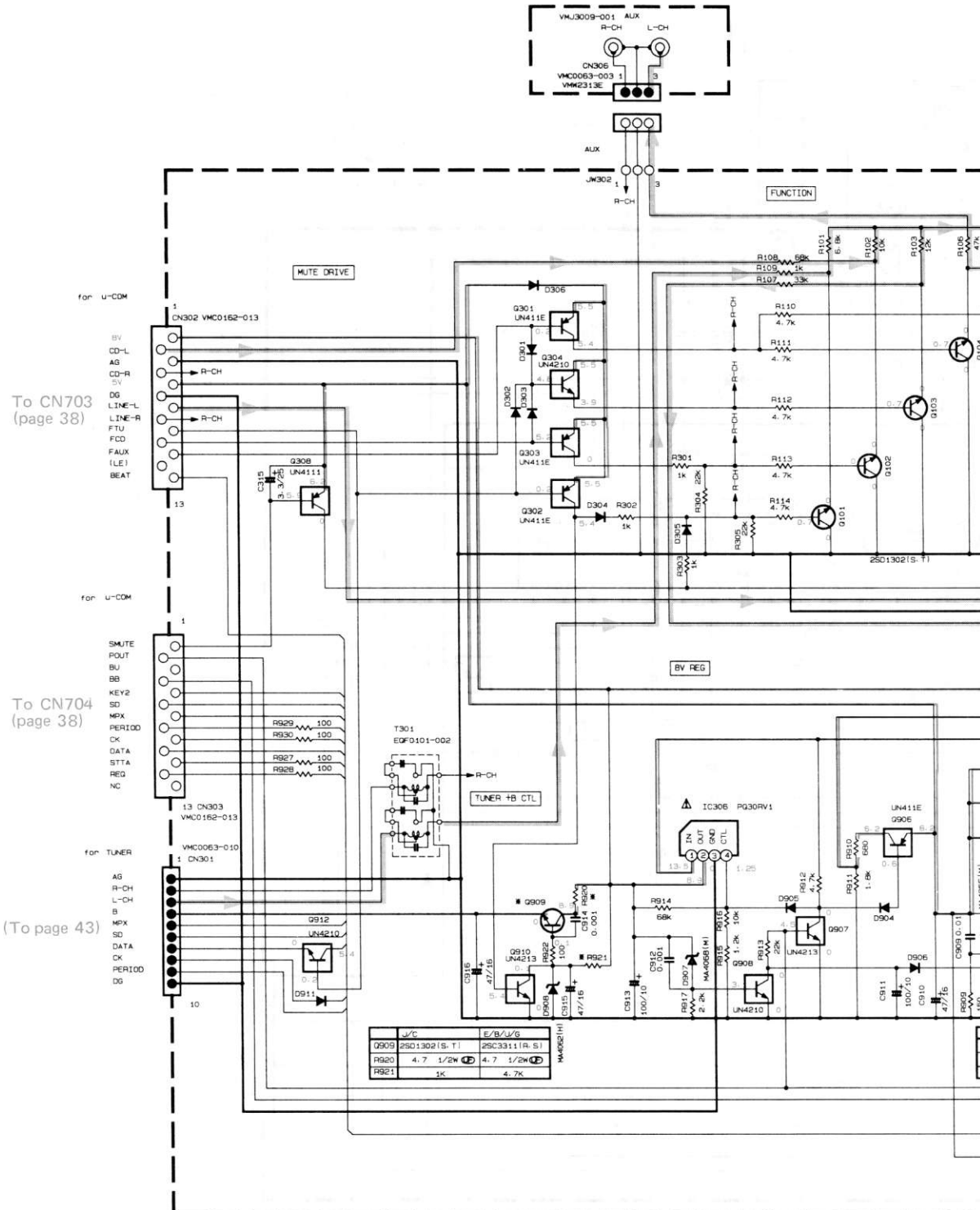

- NOTES**
- VOLTAGES ARE DC-MEASURED WITH A DIGITAL VOLT METER OR OSCILLOSCOPE WITHOUT INPUT SIGNAL. CONDITION — CD MODE
 - UNLESS OTHERWISE SPECIFIED - RESISTORS ARE 1/8W ±5% CARBON RESISTOR. ALL RESISTANCE VALUES ARE IN OHM(S). ALL CAPACITORS ARE CERAMIC CAPACITOR OR MYLAR CAPACITOR. ALL CAPACITANCE VALUES ARE IN μF(P/PF). ALL INDUCTANCE VALUES ARE IN mH(MMH). ALL E-CAPACITORS ARE SHOWN IN THE FORM OF CAPACITANCE (μF/RATED VOLTAGE (V)). ALL DIODES ARE MA165
- Ⓜ INFLAMMABLE CARBON RESISTOR
 - Ⓜ METAL FILM RESISTOR
 - Ⓜ OXIDE METAL FILM RESISTOR
 - Ⓜ 250V LOW LEAK CURRENT ELECTROLYTIC CAPACITOR
 - Ⓜ NON-POLARISED ELECTROLYTIC CAPACITOR
 - Ⓜ POLYPROPYLENE CAPACITOR
 - Ⓜ POLYSTYROL CAPACITOR

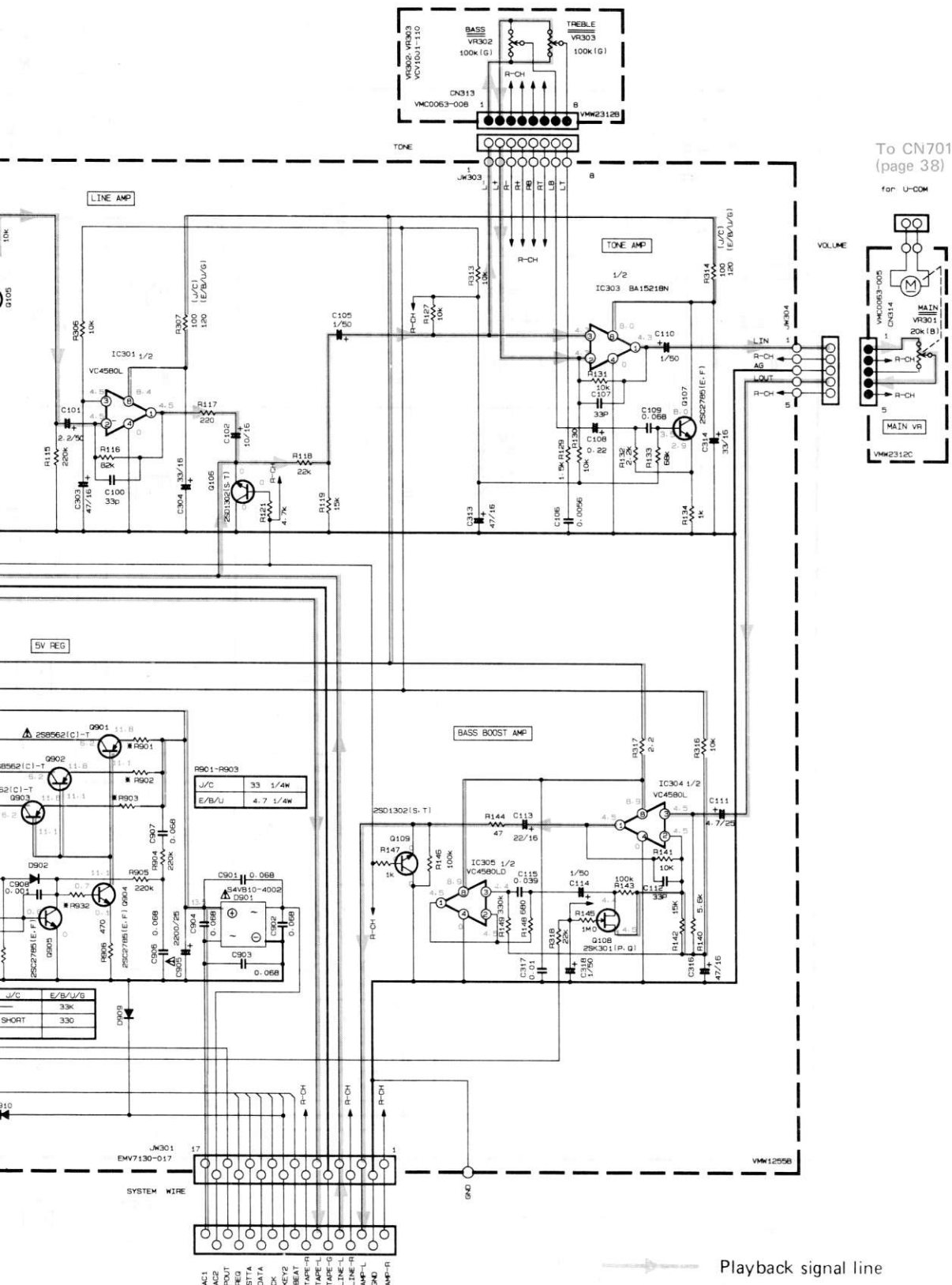

Fig. 11-12 To J352 (page 48)

1

2

3

4

5

A

B

C

D

E

F

G

■ Function P.C. Board : Drawing No. VMW1255B/UX-1E

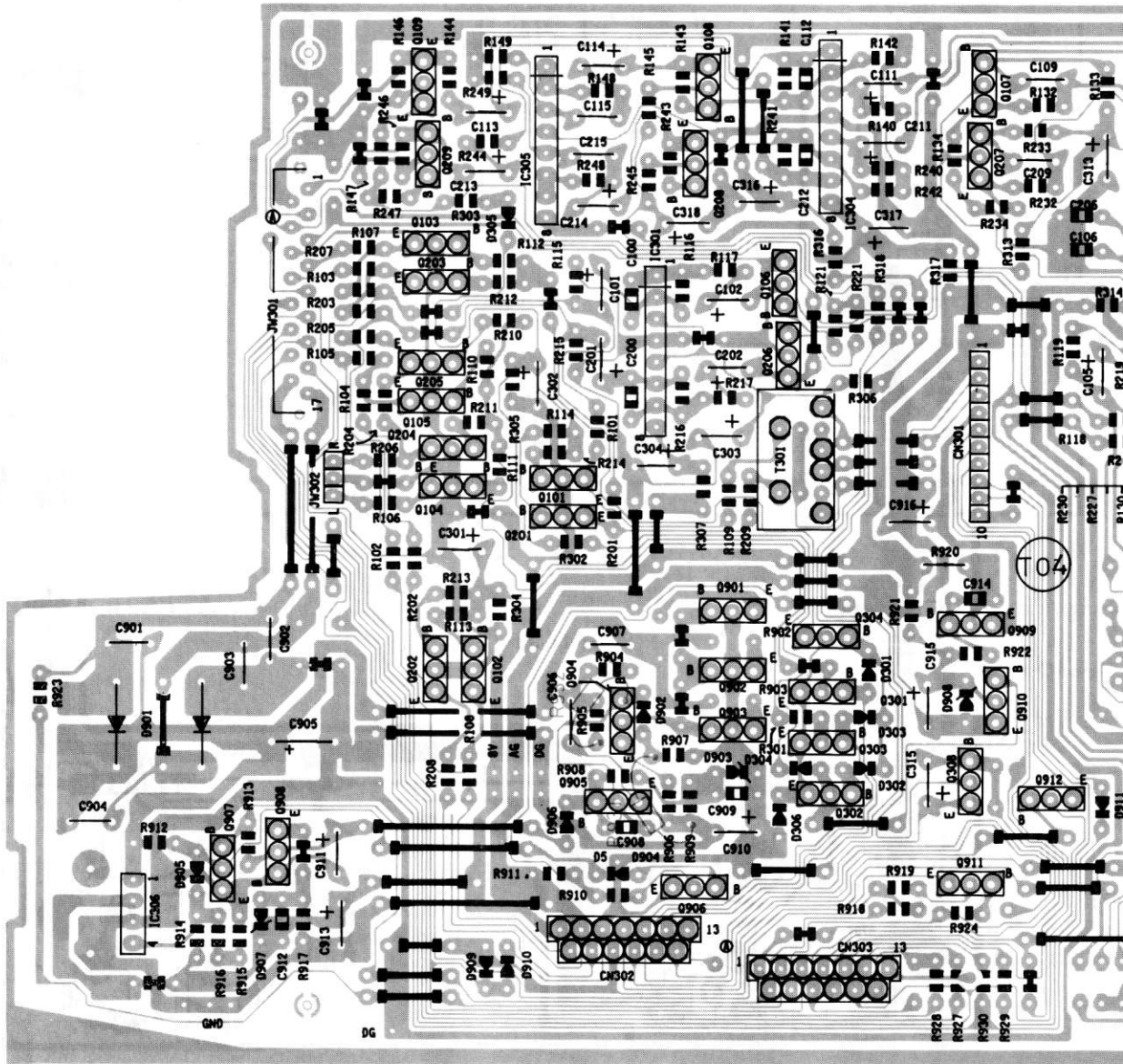
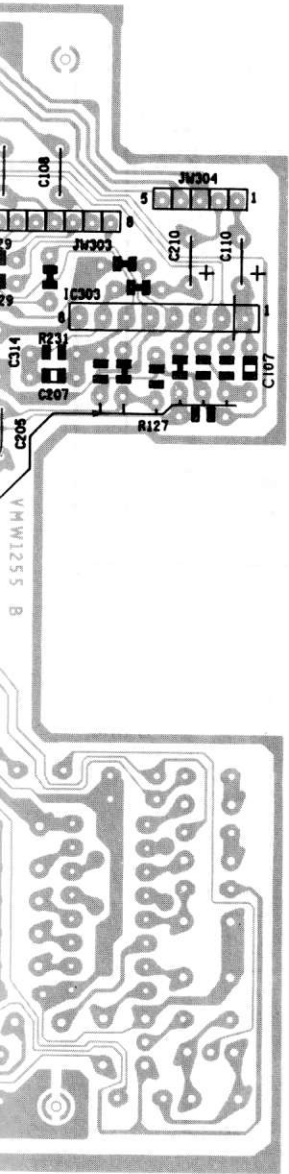

Fig. 11-13



Electric Volume P.C. Board :
Drawing No. VMW2312C

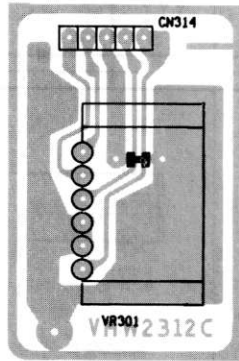

Fig. 11-14

Tone Quality Control Volume P.C. Board :
Drawing No. VMW2312B

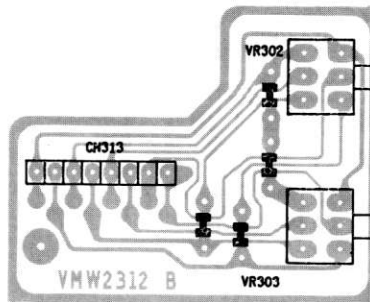
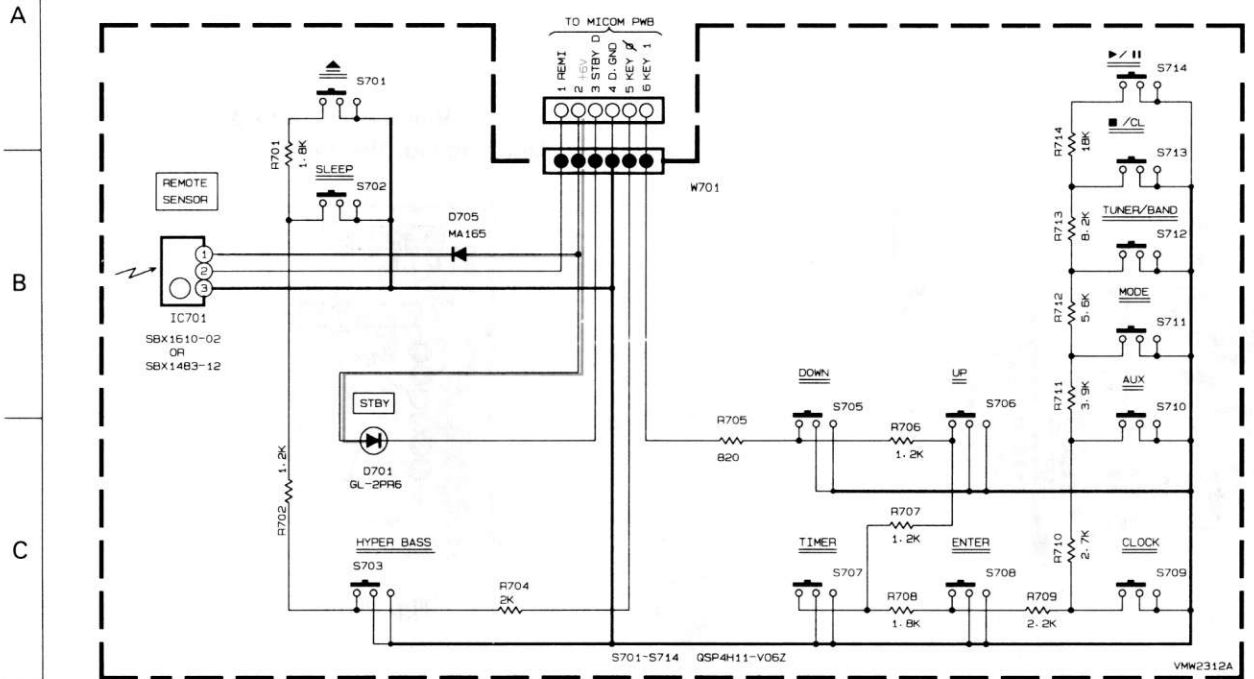

Fig. 11-15

CD Operation Section : Drawing No. VDH9159-005DX/UX-1B/E/G



NOTES

1. UNLESS OTHERWISE SPECIFIED.
 ALL RESISTORS ARE 1/6W CARBON RESISTOR.
 ALL RESISTANCE VALUES ARE IN OHM(Ω).

J: #13001-
 E: #1-
 B: #1-
 G: #1-
 U: #1-
 C: #1-

Fig. 11-16

◆ + B line

A
B
C
D
E
F
G

1 2 3 4 5

■ CD Operation P.C. Board : Drawing No. VMW2312A/UX-1E

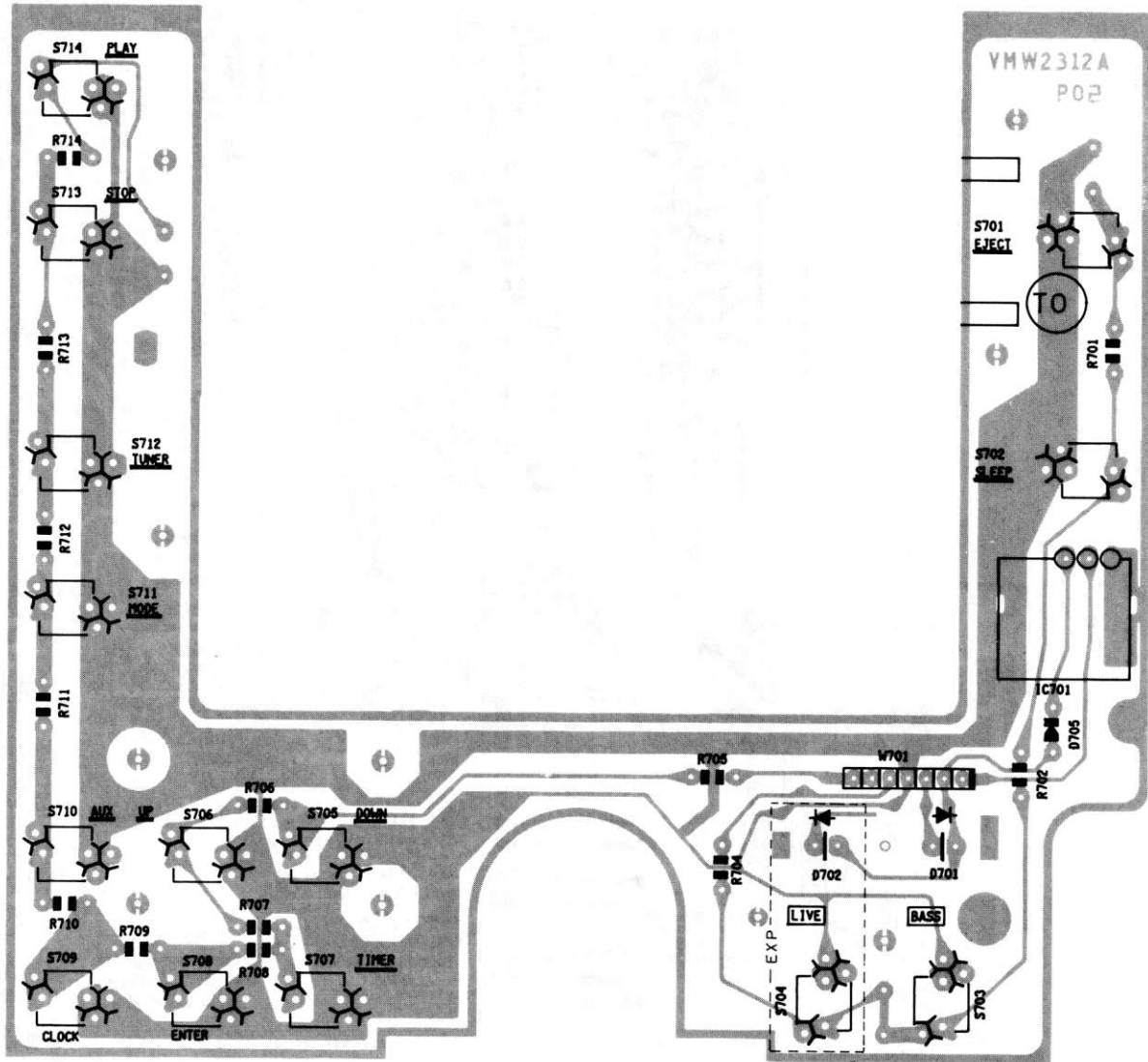

Fig. 11-17

1 2 3 4 5

■ Tape Deck, Pre-amplifier/Mechanism Control Section : Drawing No. VDH9159-005AV/UX-1E/B/G

A
B
C
D
E
F
G

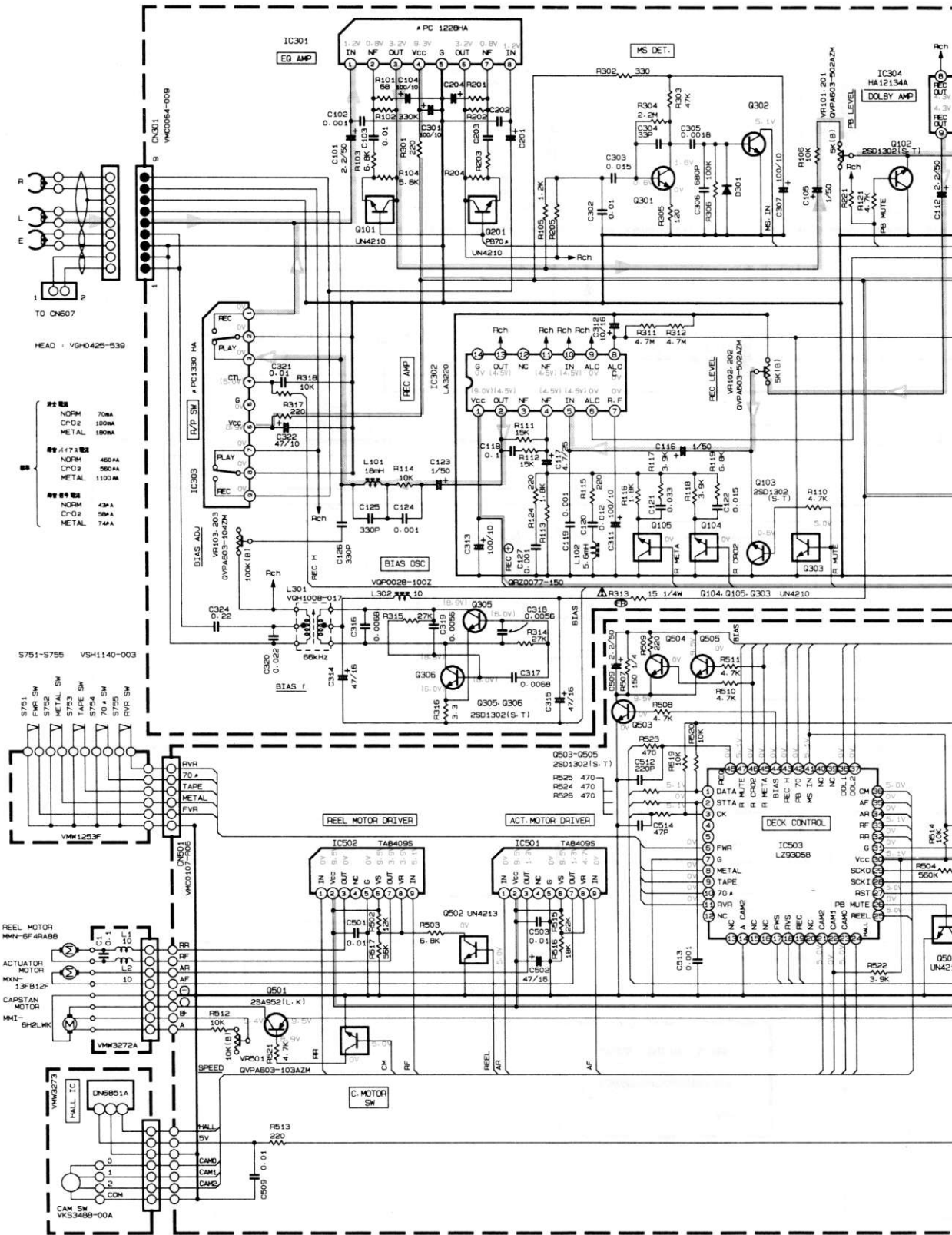
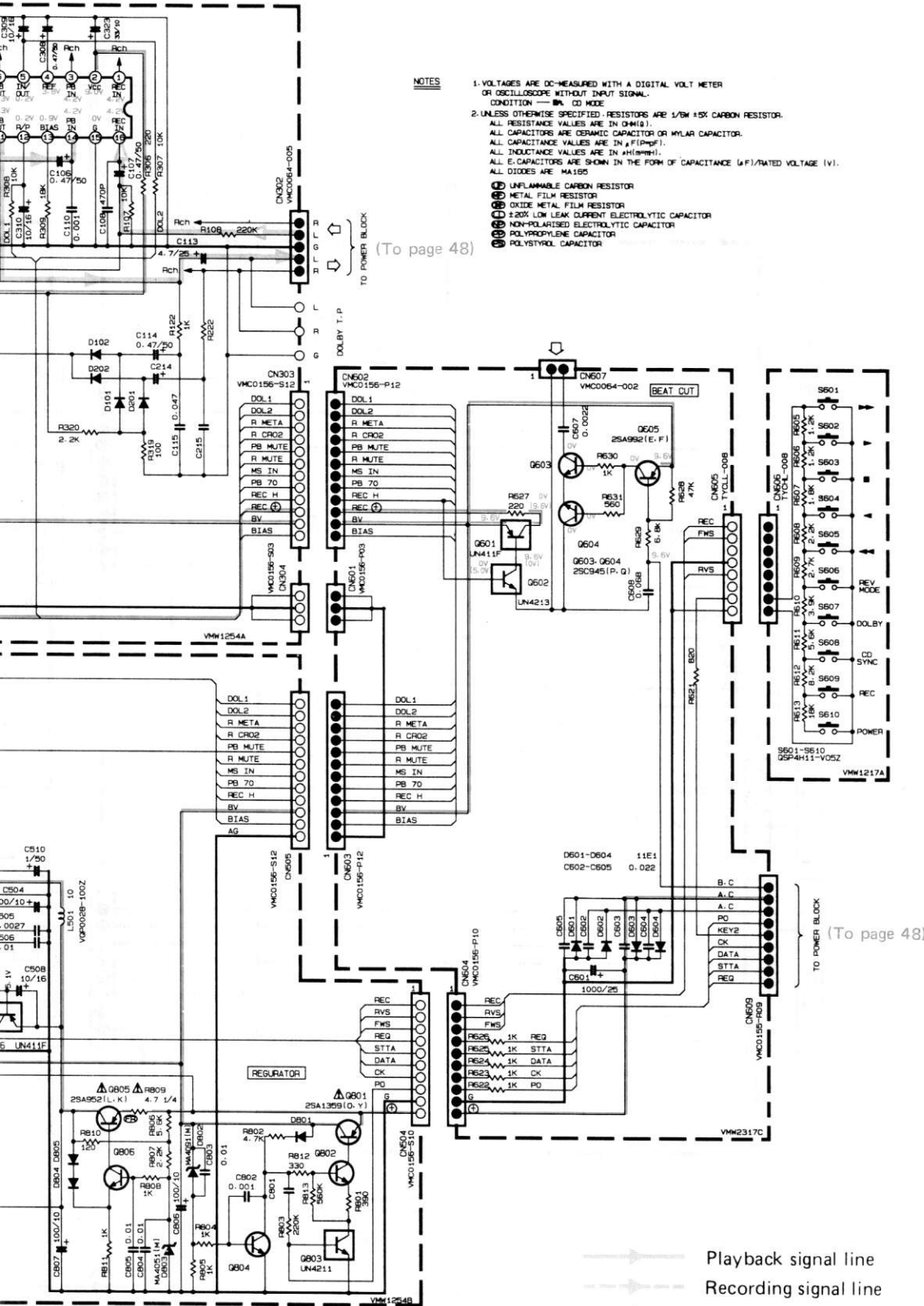

Fig. 11-18



NOTES

1. VOLTAGES ARE DC-MEASURED WITH A DIGITAL VOLT METER OR OSCILLOSCOPE WITHOUT INPUT SIGNAL.
CONDITION — PAUSE MODE
2. UNLESS OTHERWISE SPECIFIED, RESISTORS ARE 1/8W ±5% CARBON RESISTOR.
ALL RESISTANCE VALUES ARE IN OHM(Ω).
ALL CAPACITORS ARE CERAMIC CAPACITOR OR MYLAR CAPACITOR.
ALL CAPACITANCE VALUES ARE IN μF(μF).
ALL INDUCTANCE VALUES ARE IN mH(mH).
ALL E-CAPACITORS ARE SHOWN IN THE FORM OF CAPACITANCE (μF)/RATED VOLTAGE (V).
ALL DIODES ARE 1N4150

- Ⓜ UNFLAMMABLE CARBON RESISTOR
- Ⓜ METAL FILM RESISTOR
- Ⓜ OXIDE METAL FILM RESISTOR
- Ⓜ ±20% LOW LEAK CURRENT ELECTROLYTIC CAPACITOR
- Ⓜ NON-POLARISED ELECTROLYTIC CAPACITOR
- Ⓜ POLYPROPYLENE CAPACITOR
- Ⓜ POLYSTYROL CAPACITOR

(To page 48)

(To page 48)

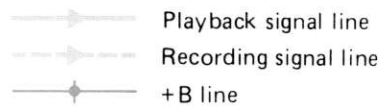

Power Supply/Power Amplifier Section : Drawing No. VDH9159-006AW/UX-1B/E/G

A
B
C
D
E
F
G

1 2 3 4 5

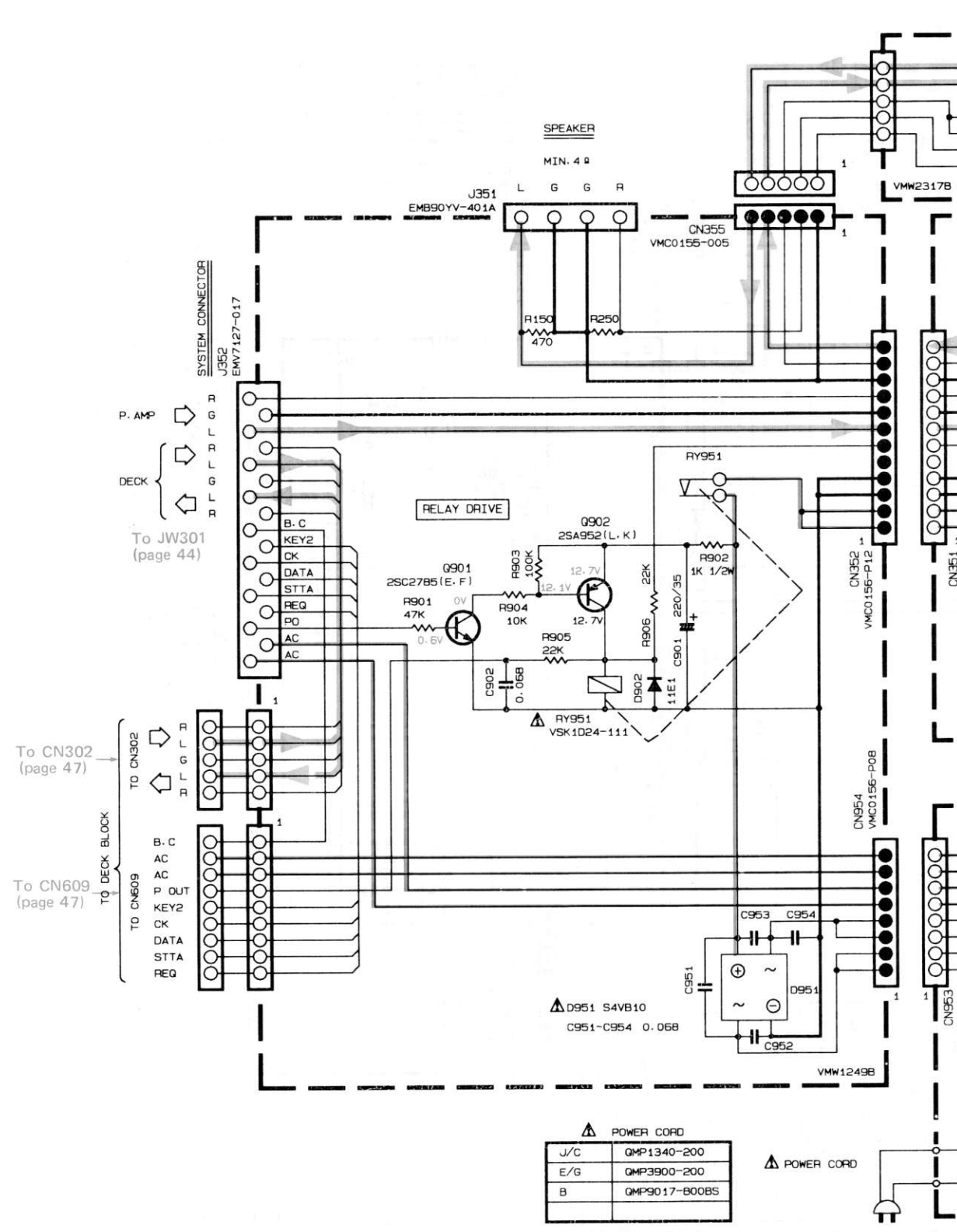

NOTES

1. VOLTAGES ARE DC-MEASURED WITH A DIGITAL VOLT METER OR OSCILLOSCOPE WITHOUT INPUT SIGNAL.
CONDITION — **CD** MODE
 2. UNLESS OTHERWISE SPECIFIED, RESISTORS ARE 1/8W ±5% CARBON RESISTOR.
ALL RESISTANCE VALUES ARE IN OHM(Ω).
ALL CAPACITORS ARE CERAMIC CAPACITOR OR MYLAR CAPACITOR.
ALL CAPACITANCE VALUES ARE IN μF(μPF).
ALL INDUCTANCE VALUES ARE IN μH(μMH).
ALL E-CAPACITORS ARE SHOWN IN THE FORM OF CAPACITANCE (μF)/RATED VOLTAGE (V).
ALL DIODES ARE MA165
- Ⓛ UNFLAMMABLE CARBON RESISTOR
 - Ⓜ METAL FILM RESISTOR
 - Ⓞ OXIDE METAL FILM RESISTOR
 - Ⓟ ±20% LOW LEAK CURRENT ELECTROLYTIC CAPACITOR
 - Ⓠ NON-POLARISED ELECTROLYTIC CAPACITOR
 - Ⓡ POLYPROPYLENE CAPACITOR
 - Ⓢ POLYSTYROL CAPACITOR

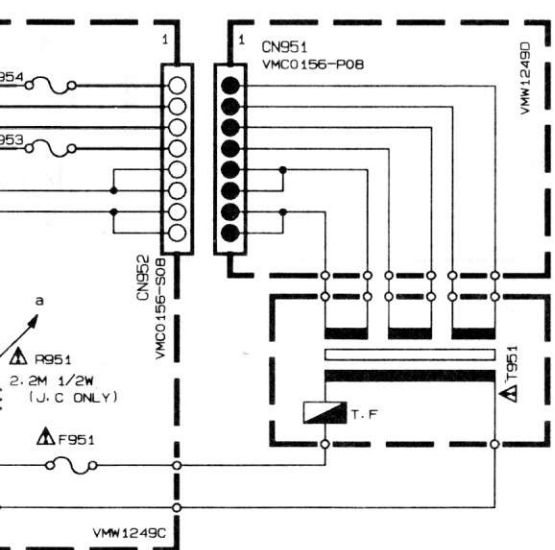
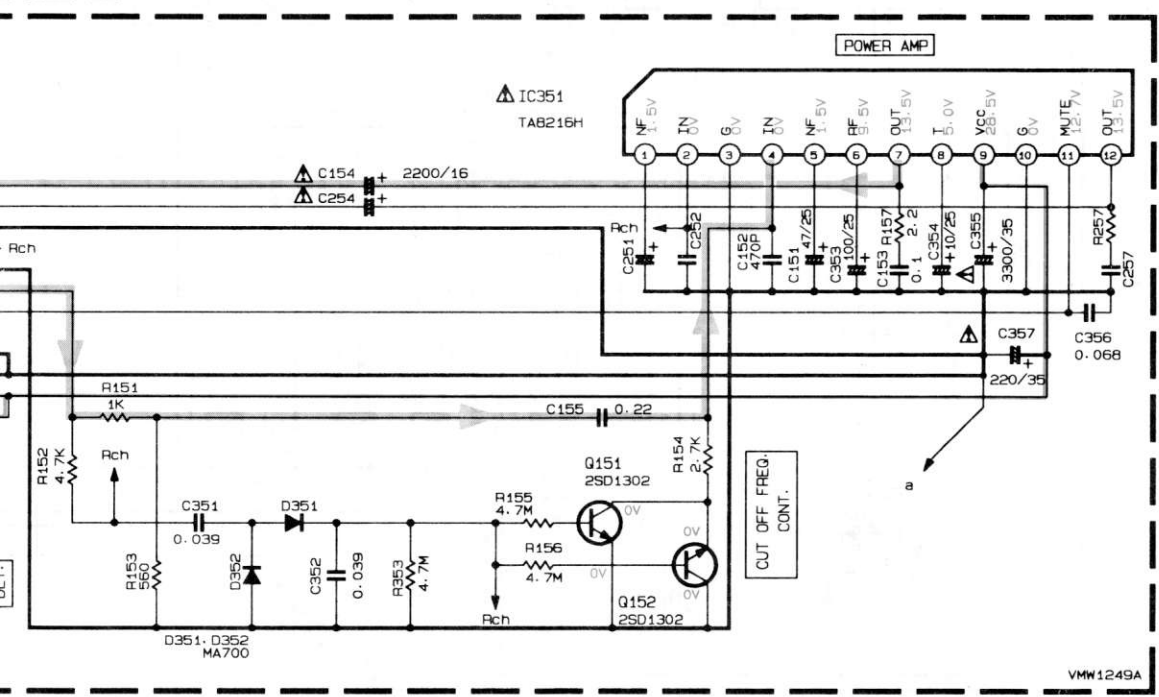
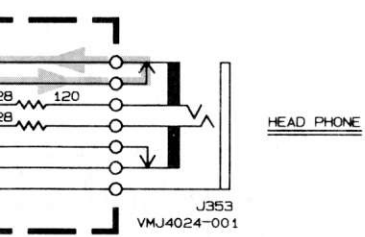

T951 POWER TRANS

J/C	VTP66A6-24A
E/G	VTP66J6-24A
B	VTP66T6-24A

FUSE

	F951	F953	F954
J/C	1.6A/125V GMF51U1-1R6	2A/125V GMF51U1-2R0	800mA/125V GMF51U1-R80
E/G	T630mA GMF51A2-R63	T1.6A GMF51A2-1R6	T630mA GMF51A2-R63
B	T630mA GMF51E2-R63BS	T1.6A GMF51E2-1R6BS	T630mA GMF51E2-R63BS

Fig. 11-19

1

2

3

4

5

A

B

C

D

E

F

G

■ Pre-amplifier P.C. Board : Drawing No. VMW1254A

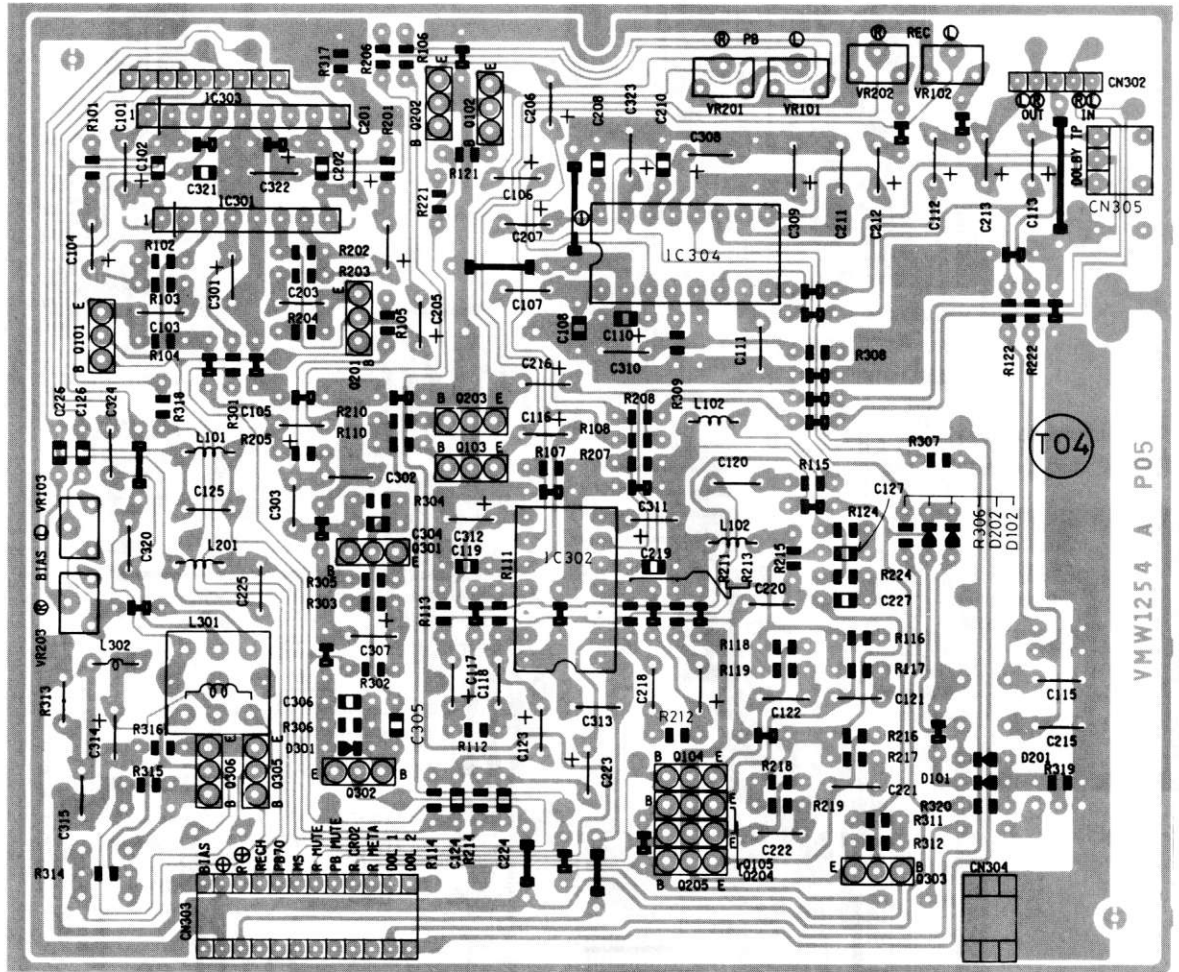

Fig. 11-20

■ Headphone Jack P.C. Board : Drawing No. VMW2317B

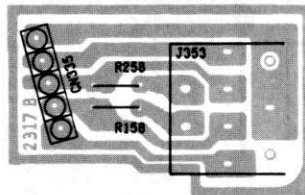

Fig. 11-21

■ Relay P.C. Board : Drawing No. VMW2317C/UX-1B

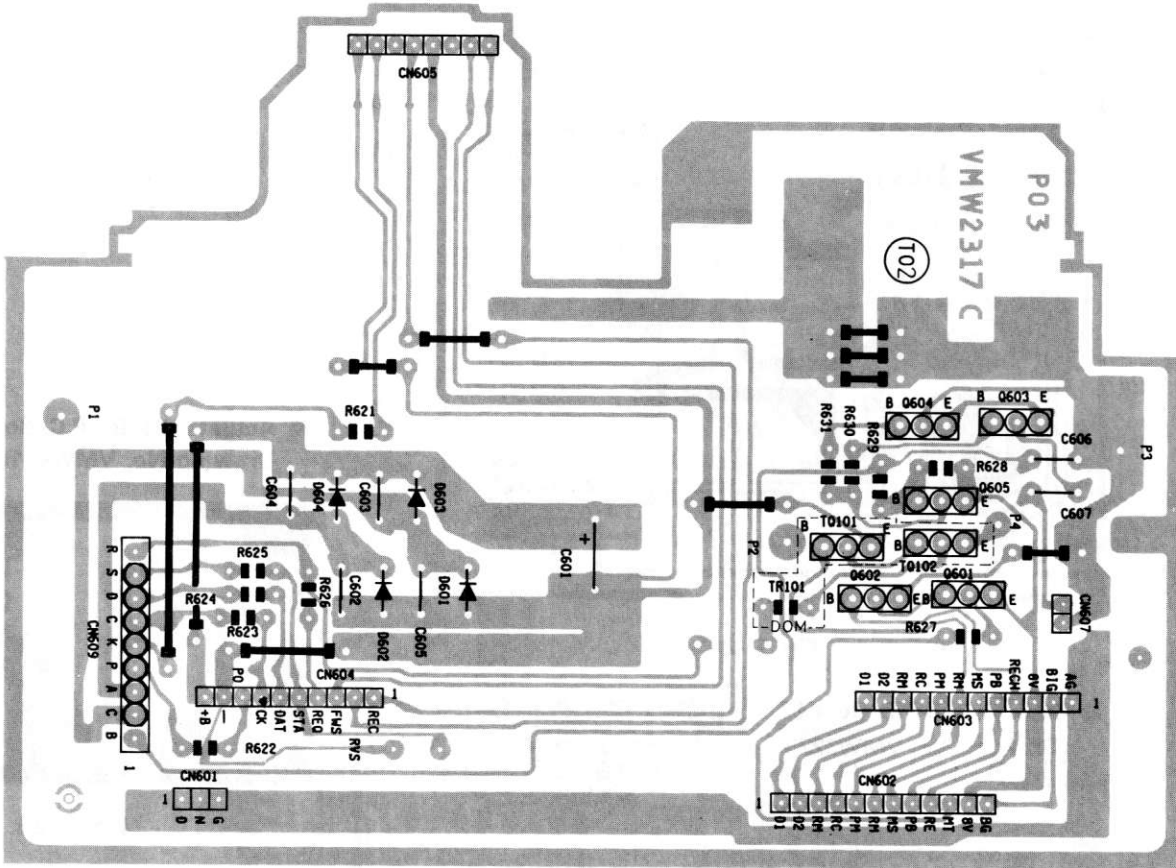

Fig. 11-22

■ Tape Deck Operation Key Switch P.C. Board : Drawing No. VMW2317A/UX-1E

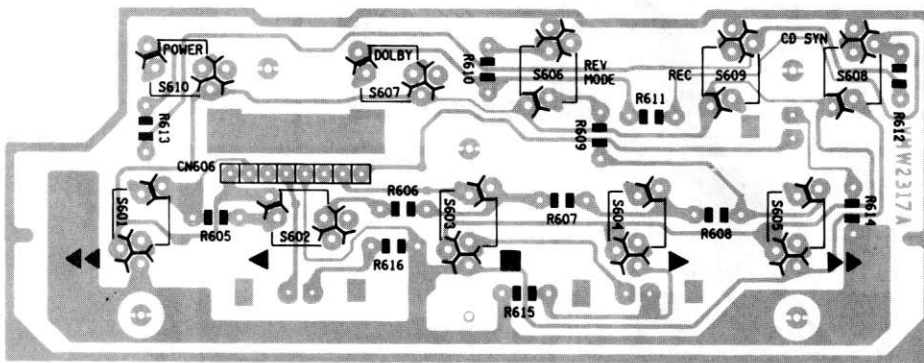

Fig. 11-23

1 2 3 4 5

A
B
C
D
E
F
G

■ Reel Motor P.C. Board : Drawing No. VMW3272

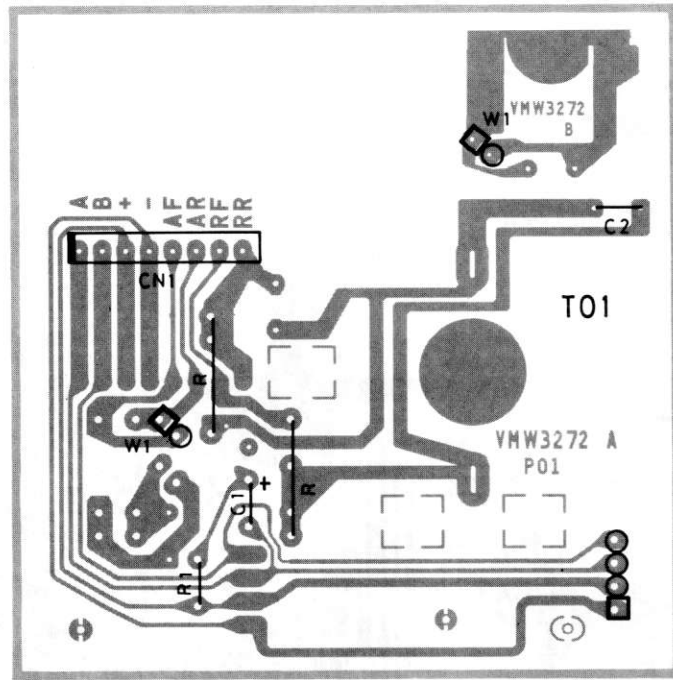

Fig. 11-24

■ Cam Switch P.C. Board : Drawing No. VMW3273

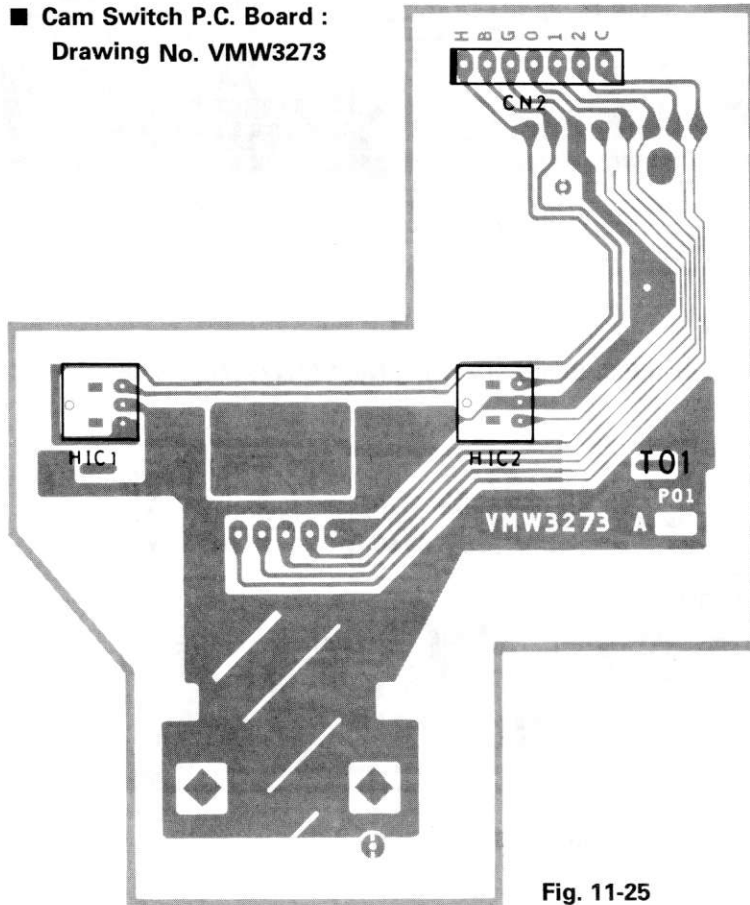

Fig. 11-25

■ Actuator Motor P.C. Board : Drawing No. VMW4816

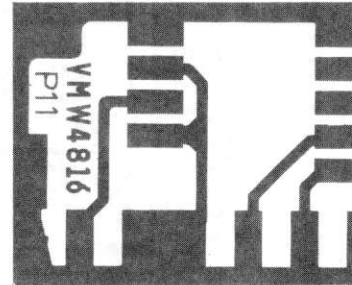

Fig. 11-26

■ Mechanism Control P.C. Board : Drawing No. VMW1254B/UX-1E

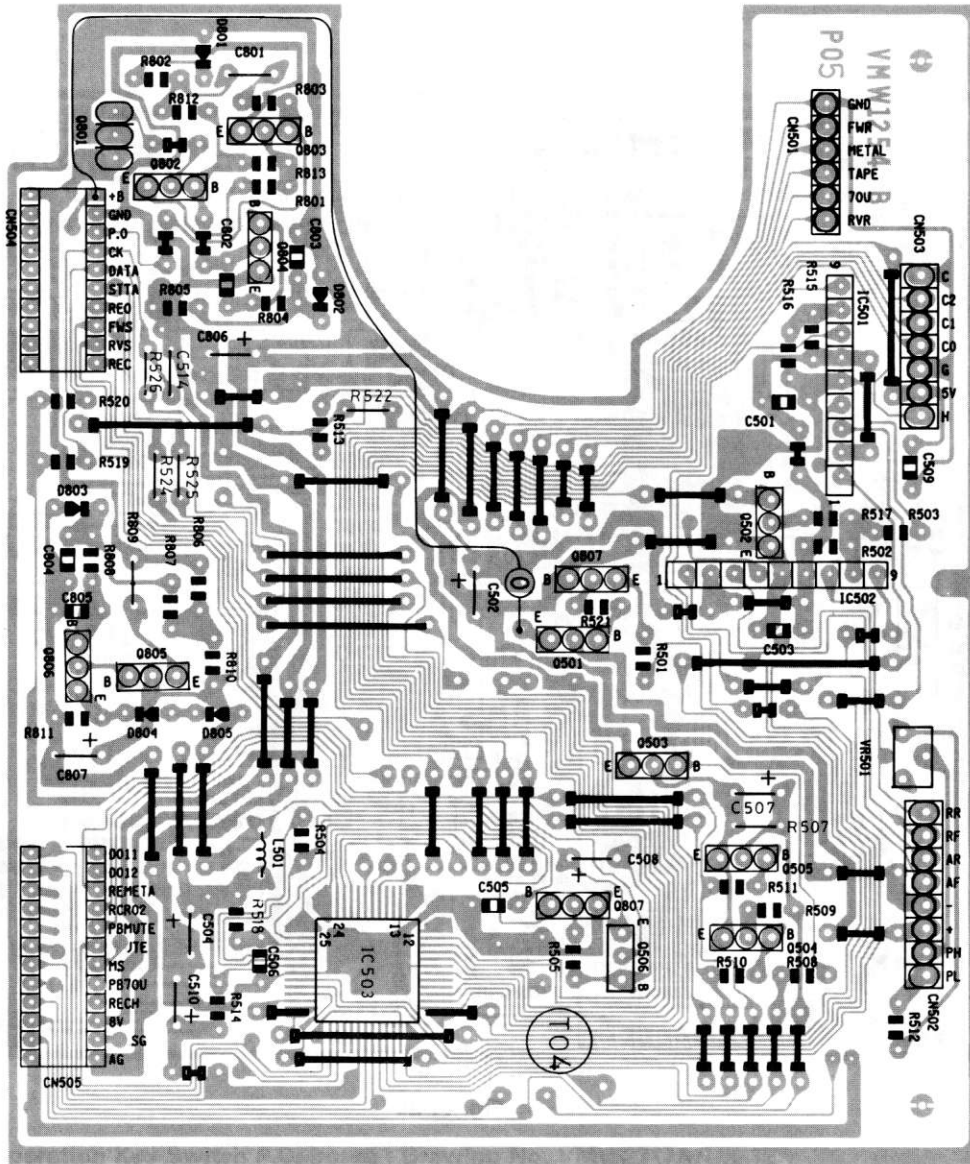

Fig. 11-27

■ Leaf Switch P.C. Board : Drawing No. VMW1253F/UX-1E

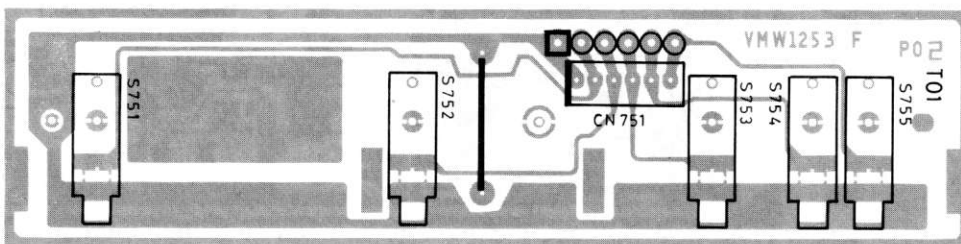
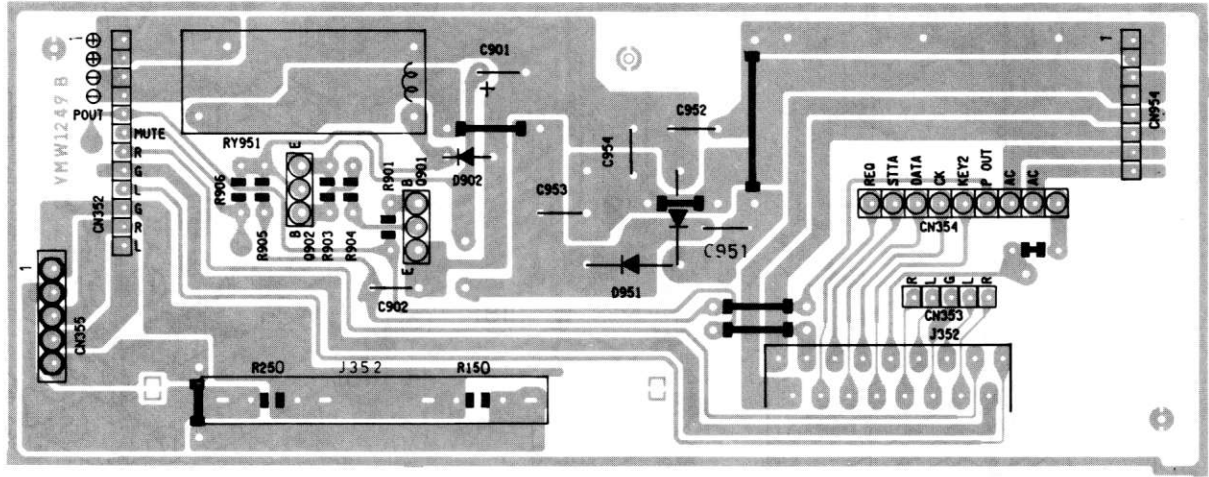

Fig. 11-28

A

■ Relay Drive P.C. Board : Drawing No. VMW1249B



B

C

Fig. 11-29

D

■ Power Amplifier P.C. Board : Drawing No. VMW1249A

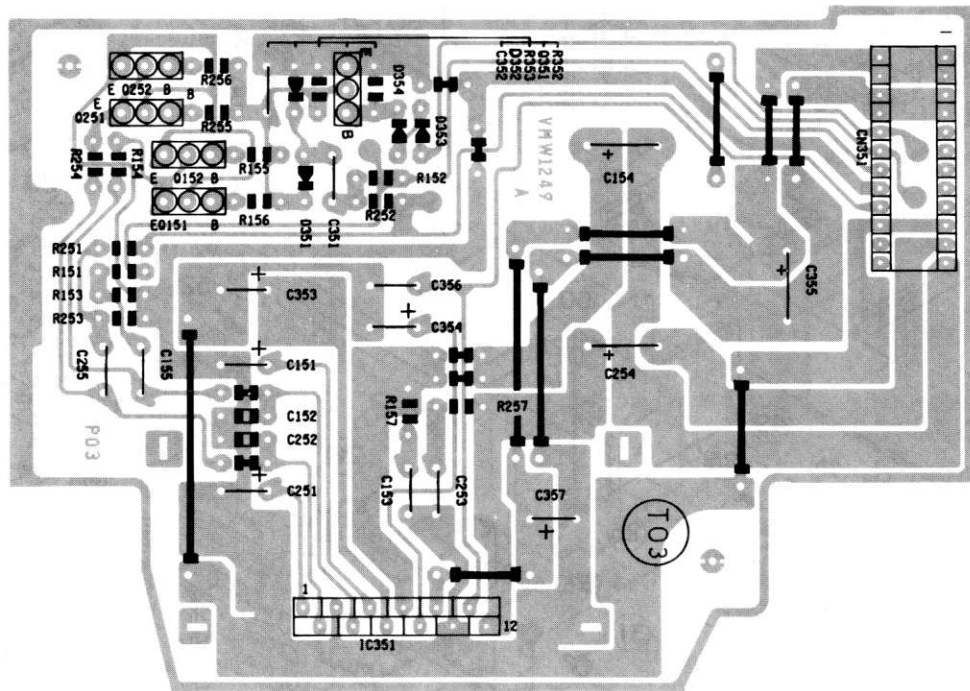

E

F

G

Fig. 11-30

6 | 7 | 8 | 9 | 10

■ Power Supply, Relay P.C. Board : Drawing No. VMW1249C

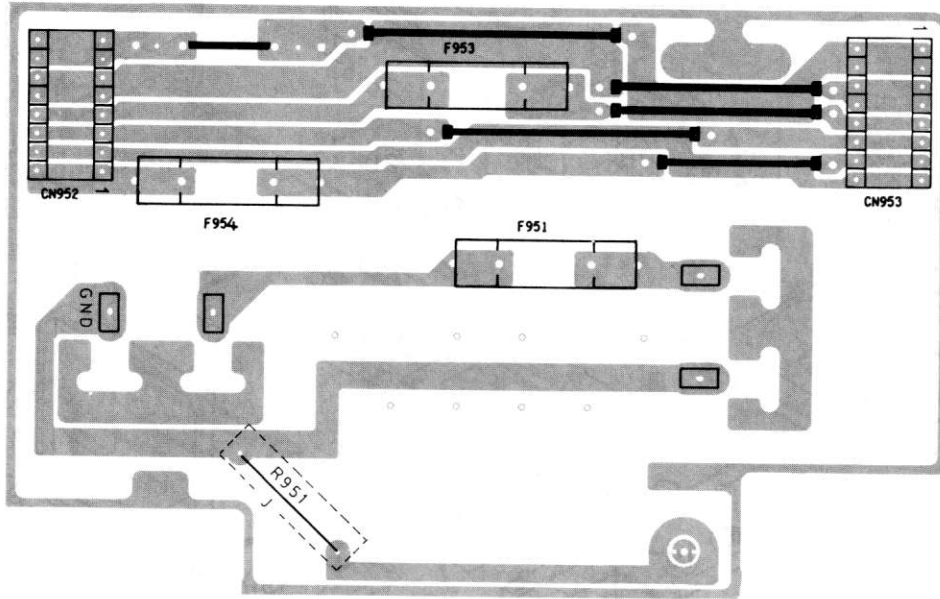

Fig. 11-31

Power Supply, Relay P.C. Board : Drawing No. VMW1249D

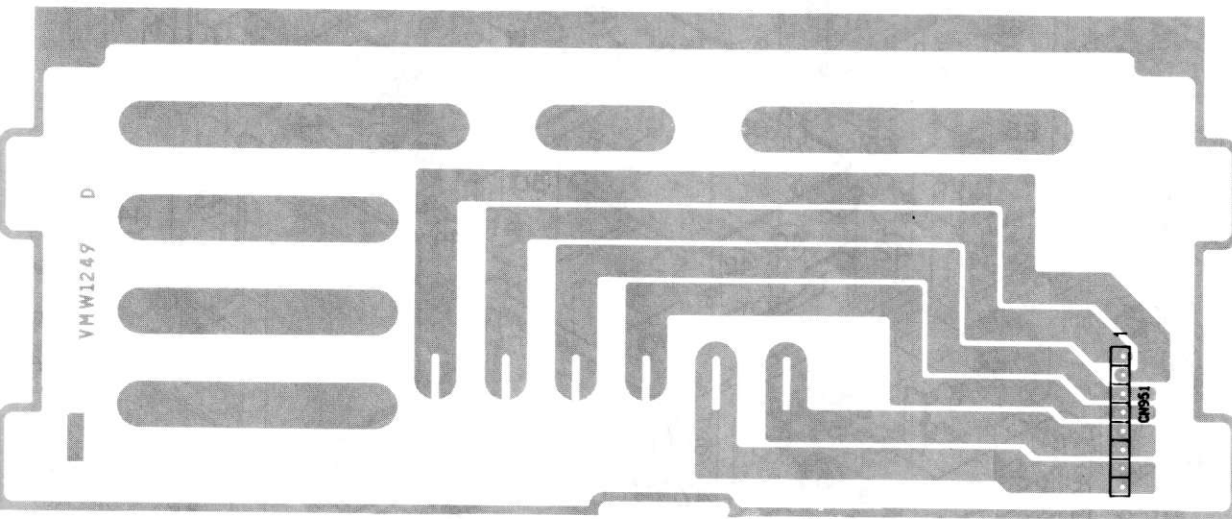
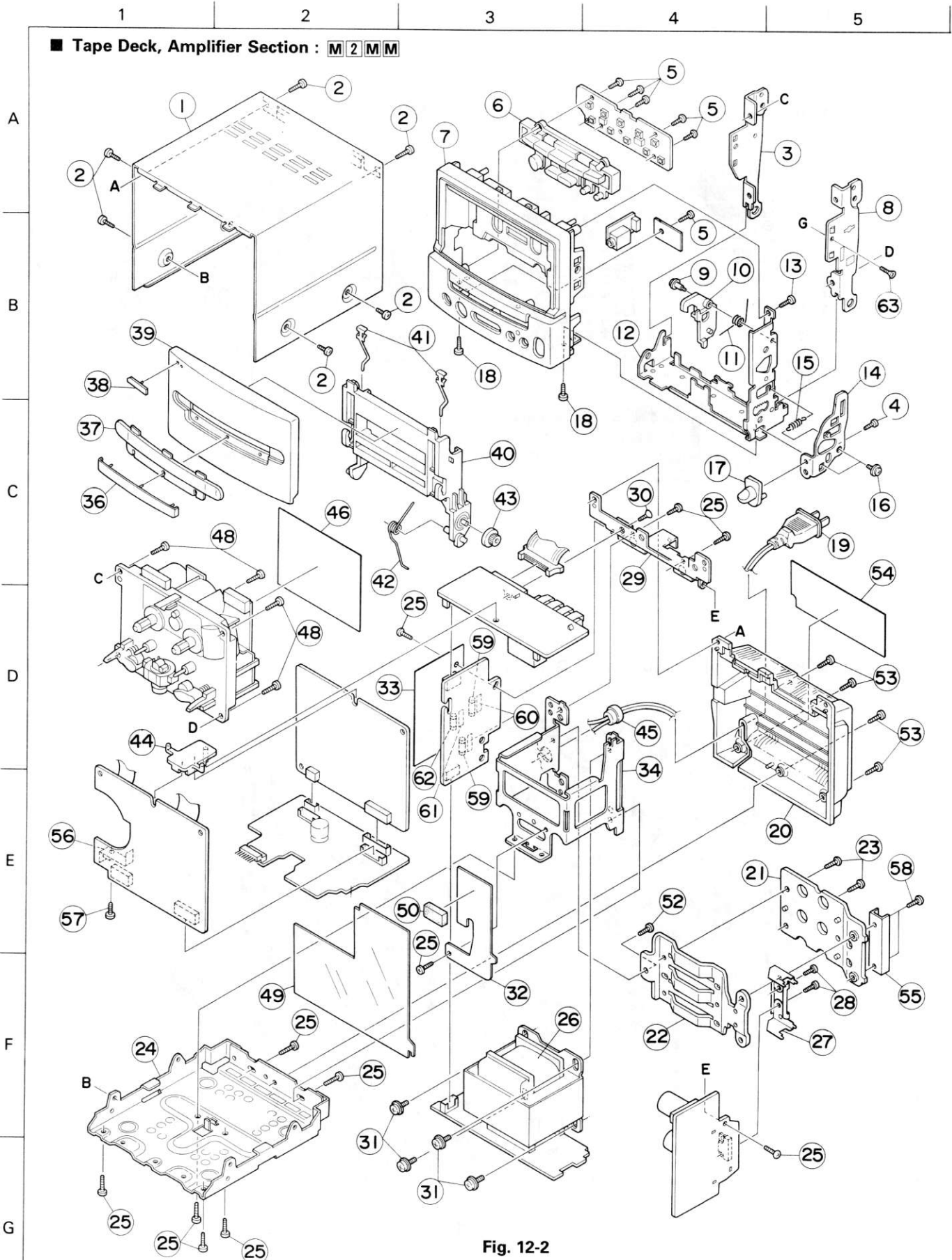

Fig. 11-32

Parts and Parts List



■ CD Receiver Section

Block No. **M I M M**

△	REF.	PARTS NO.	PARTS NAME	REMARKS	QTY
	56,58,59 72	ZCUXR1K-FBK	FRONT CABINET ASS'Y		1
	1	VJT3311-003	CD DOOR LENS		1
	2	VJT2265-003	CD DOOR		1
	3	VJD1149-002UL	CD CASE		1
	4	MXN-13FB12F	DC MOTOR ASS'Y	CD DOOR	1
	5	VYH3659-001	GEAR BRACKET		1
	6	VYH7358-001	GEAR(B)		1
	7	VYH7357-001	GEAR(A)		1
	8	VYH7356-002	PULLEY		1
	9	VKB3000-144	BELT		1
	10	GBSF3006Z	SCREW	PULLEY/GEAR BKT	1
	11	SBSF3010Z	SCREW	CD CASE/GEAR BKT	2
	12	SPSP3004Z	SCREW	DC MOTOR/GEAR BKT	2
	13	E75054-001	PULLEY	FOR DC MOTOR	1
	14	SBSF3010Z	SCREW		4
	15	EXL-M5C	CD MECHA		1
	16	E75609-001	INSULATOR	FOR CD MECHA.	2
	17	E75609-002	INSULATOR	FOR CD MECHA.	1
	18	VYH7297-101	HOLDER		1
	19	SBSF3010Z	SCREW	HOLDER/CD CASE	2
	20	VJD5318-002	PICK COVER		1
	21	SDST2006M	SCREW	PICKUP COVER	3
	22	VYH3660-003	CLAMPER PLATE		1
	23	VYH7313-001R	MAGNET		1
	24	E306835-001	CLAMPER		1
	25	VYH7348-002	VOLUME BRACKET		1
	26	SBSF2610Z	SCREW	VOLUME/BRACKET	1
	27	VYTT575-001	FILTER	FOR LCD	1
	28	VYH3663-002	LCD HOLDER		1
	29	VYH7365-002	LAMP CASE		2
	30	SBSF2606Z	SCREW	LAMP CASE	2
	31	VGZ0001-041	P.LAMP	PL701	1
		VGZ0001-041	P.LAMP	PL702	1
	32	VQZ0029-005	AM LOOP ANTENA		1
	33	VJD5335-001	LOOP ANT HOLDER		1
	34	SDSF3010M	SCREW		1
	35	E65923-003	T.SCREW	JACK PCB/REAR PAN	3
	36	SSST3006Z	SCREW	REAR/CHASSIS	4
	37	VJC1962-006	REAR PANEL(T)		1
	38	SBST3006Z	SCREW	DISPLAY BOARD	3
	39	SBST3006Z	SCREW	FUNCTION BOARD	4
	40	VYH7349-001	CHASSIS BRACKET	FRONT	1
	41	VYH7350-001	CHASSIS BRACKET	REAR	1
	42	SBST3006Z	SCREW	S.CHASSIS, BRACKET	4
	43	VJC2411-002	METAL COVER		1
	44	SDST3006M	SCREW	METAL COVER	4

△	REF.	PARTS NO.	PARTS NAME	REMARKS	QTY
	45	VJF4003-003	FOOT		4
	46	VYH3657-001	SIDE CHASSIS(R)		1
	47	VYH3656-001	SIDE CHASSIS(L)		1
	48	SBSF3010M	T.SCREW	METAL COVER	1
	50	SBST3006Z	SCREW	TUNER BOAD, CHASSI	2
	51	VXP3418-001	PUSH KNOB	AUX, CLOCK/DISPLAY	1
	52	VXP5029-001	PUSH KNOB	TIMER/BAND, FM MOD	1
	53	VXP5027-001	PUSH KNOB	PLAY/PAUSE, STOP	1
	54	VXP5030-002	PUSH KNOB	HYPER-BASS	1
	55	VXP5026-001	PUSH KNOB	OPEN/CLOSE, SLEEP	1
	56	VJC1961-003	FRONT PANEL(T)		1
	57	VXL4375-004	VOLUME KNOB		1
	58	VJT4181-003	LCD LENS(DOWN)		1
	59	VJT4180-001	LCD LENS(UP)		1
	60	PQ42561-2	MARK	JVC	1
	61	SSST3006Z	SCREW	FRONT/CHASSIS	4
	62	VXL4374-001	KNOB	BASS, TREBLE	2
	63	SBSF3006Z	SCREW	SWITCH PCB/CD CAS	1
	64	SBSF3010Z	SCREW	SWITCH BRACKET	1
	65	SBSF2610Z	SCREW	OPERATION BOARD	6
	66	VCV1001-101	VR WITH MOTOR	VR301 MAIN VOLUME	1
	67	VYN9159-101	NAME PLATE		1
	68	VYH3662-001	BUSHING		1
	69	SDSF3008Z	SCREW	CD/CHASSIS UNIT	2
	70	VMA4494-001	SHIELD(TUNER)		1
	71	VYH7363-003	LED HOLDER		1
	72	VYTT574-001	FILTER	REMOTE SENSOR	1
	73	E65923-003	T.SCREW		1
	75	VMH4032-H25B	HEAT SINK		1
	76	VMPO092-001	SYSTEM WIRE ASY		1
	77	E71541-001	E.I.LASER MARK	CD CASE SERFACE	1
	78	VND4220-001	LASER CAUTION	CD CASE BACK	1
	79	VND4221-001	CLASS 1 LABEL	BOTTOM	1
	80	VYH7519-001	JACK BRACKET		1
	81	VYSH201-004	SPACER	CLAMPER COVER	3

■ Tape Deck, Amplifier Section

Block No. **M2MM**

△	REF.	PARTS NO.	PARTS NAME	REMARKS	QTY
	36~39	ZCUXD1K-CLBK	CASSETTE DOOR ASS'Y		1
	40, 41	ZCUXD1K-CH	CASSETTE HOLDER ASS'Y		1
	1	VJC2412-001	TOP COVER		1
	2	SDST3008M	SCREW		6
	3	VYH7351-001	MECHA HOLDER L		1
	4	SSSF2608Z	SCREW	EJECT KNOB	1
	5	SBSF2606Z	SCREW	FRONT+PCB	5
		SBSF2606Z	SCREW	H. PHONES	1
	6	VXP3417-001	BUTTON		1
	7	VJC1959-003	FRONT PANEL	#F	1
	8	VYH7352-001	MECHA HOLDER R		1
	9	VKZ4341-001	SPECIAL SCREW	EJECT ARM	1

REF.	PARTS NO.	PARTS NAME	REMARKS	QTY
10	VYH7347-001	EJECT ARM		1
11	VKW4938-001	TORTION SPRING		1
12	VYH7345-002	DOOR HOLDER		1
13	SDSF3010Z	SCREW	DOOR HOLDER/FRONT	1
14	VYH7346-001	EJECT LEVER		1
15	VKW3002-274	TENSION SPRING	EJECT LEVER	1
16	VKZ4323-002	SCREW	EJECT LEVER	2
17	VXQ4109-001	EJECT KNOB		1
18	SDST3006Z	SCREW	DOOR HOLDER/FRONT	2
19	QMP3900-200	POWER CORD		1
20	VJC1960-005	REAR PANEL (D)		1
21	VYH7361-001	RADIATION (A)		1
22	VYH7362-001	RADIATION (B)		1
23	GBSF3010Z	TAPPING SCREW	HEAT SINK AXB	2
24	VJC3205-001	BOTTOM COVER		1
25	SDST3006Z	SCREW	JACK HOLDER	2
	SDST3006Z	SCREW	SHIELD/TRANS BKT	1
	SDST3006Z	SCREW	JACK HOLDER/PCB	2
	SDST3006Z	SCREW	TRANS BKT	2
	SDST3006Z	SCREW	TRANS BKT	2
26	VTP66J6-24A	POWER TRANS	T951	1
27	VYH7360-001	IC HOLDER		1
28	SBSF3008Z	SCREW	RADIATION AXB	2
	SDSF3008Z	SCREW	IC/IC HOLDER	2
29	VYH7355-001	JACK HOLDER		1
30	SSSF3008Z	SCREW	JACK HOLDER	1
31	VKZ3001-002	SPECIAL SCREW	FOR TRANS	4
32	VMA4485-001	SHIELD PLATE		1
33	VMA4507-001	BARRIER		1
34	VYH3658-001	TRANS BRACKET		1
36	VJD5334-002	DOOR ORNAMENT		1
37	VJT4179-001	DOOR LENS		1
38	PQ42561-2	MARK	JVC	1
39	VJT2264-002	DOOR COVER		1
40	VJT2263-001	CASS DOOR		1
41	VKY4180-001	CASSETTE SPRING		2
42	VKW4939-002	DOOR SPRING		1
43	VYH5601-001	GEAR		1
44	VYH7353-001	PCB HOLDER		1
45	QHS3876-162	S.R.BUSHING	POWER CORD	1
46	VYSH106-051	SPACER	17	1
48	SDST3008Z	SCREW		2
	SDST3008Z	SCREW		2
49	VMA4496-001	INSULATOR	PRE PCB	1
50	VYSH105-033	SPACER		1
52	SDST3006Z	SCREW		1
53	SDST3008M	SCREW		4
54	VYN9159-122	NAME PLATE		1
55	VYH7478-001	HEAT SINK. (A)		1
56	VYH7479-001	HEAT SINK (B)		1
57	SDST2608Z	SCREW		1
59	QMF51A2-R63	FUSE	F951	1
	QMF51A2-R63	FUSE	F954	1
60	VND4003-072	FUSE LABEL		1
	VND4003-072	FUSE LABEL		1
61	VND4003-073	FUSE LABEL		1
62	QMF51A2-1R6	FUSE	F953	1
63	SSST3006Z	SCREW	MECHA HOLDER/FRON	1

1

2

3

4

5

■ Cassette Mechanism Sections : M 3 M M

A

B

C

D

E

F

G

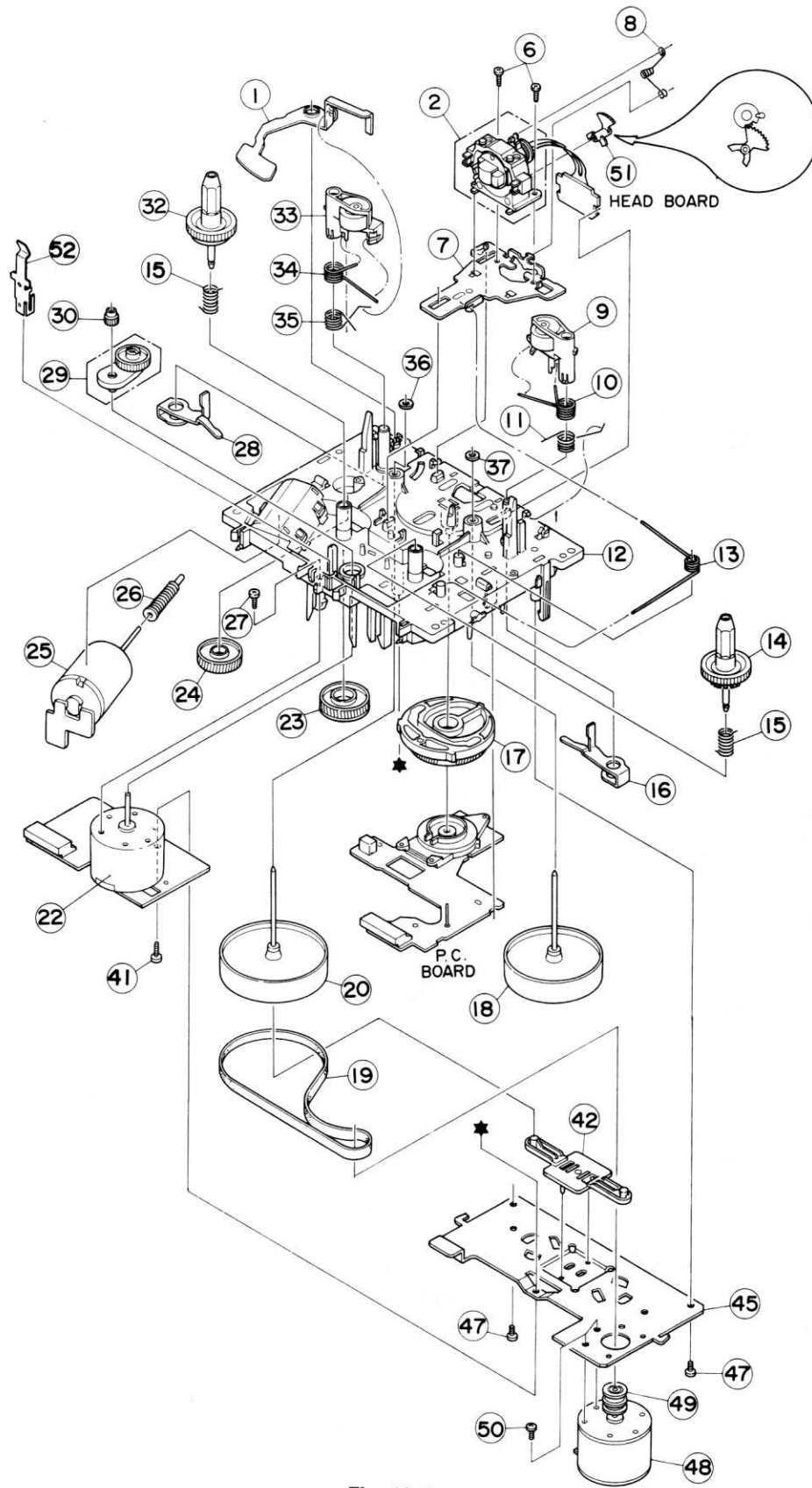

Fig. 12-3

■ Cassette Mechanism Sections

Block No. **M3MM**

△	REF.	PARTS NO.	PARTS NAME	REMARKS	QTY
	25,26	MXN13FB12F-SA1	REEL MOTOR ASS'Y		1
	48,49	MMI6H2LWK-SA4	CAPSTAN MOTOR ASS'Y		1
	2	V DG5149-002MB1	HEAD MOUNT ASS'Y		1
	1	VKL6954-006	EJECT SAFETY(R)		1
	6	SDST2004Z	SCREW	MOUNT BASE	2
	7	VKL6942-00C	HEAD BASE AS'Y		1
	8	VKW4914-007	HEAD SPRING	HEAD GEAR, FROM 310	1
	9	VKP4221-00A	PINCH R.(L) ASY		1
	10	VKW4982-001	SPRING	PINCH ROLLER(L)	1
	11	VKW4933-003	TORSION SPRING	PINCH ROLLER ARM(1
	12	VKS1112-30E	CHASSIS B ASSY		1
	13	VKW4930-002	RETURN SPRING	HEAD BASE	1
	14	VKS3480-003	REEL		1
	15	VKW4928-002	B.T. SPRING		1
		VKW4928-002	B.T. SPRING		1
	16	VKL6940-002	PINCH LEVER (L)		1
	17	VKS2209-004	CONTROL CAM		1
	18	VKF3182-00E	FLYWHEEL(L)ASY		1
	19	VKB3001-049	BELT		1
	20	VKF3180-00E	FLYWHEEL(R)ASY		1
	22	MMN-6F4RA88	D.C.MOTOR	FOR REEL	1
	23	VKS5331-002	ACT. GEAR (6)		1
	24	VKS5330-003	ACT. GEAR (5)		1
	25	MXN-13FB12F	DC MOTOR ASS'Y	ACTUATEOR	1
	26	VKS5329-001	ACTUATOR GEAR4		1
	27	SDSP2605Z	SCREW		1
	28	VKL6939-002	PINCH LEVER (R)		1
	29	VKS5325-00E	FR ARM ASY		1
	30	VKS5328-002	GEAR	REEL MOTOR	1
	32	VKS5321-00C	T-UP REEL ASS'Y		1
	33	VKP4219-00A	PINCH R.(R) ASY		1
	34	VKW4981-001	SPRING	PINCH ROLLER(R)	1
	35	VKW4932-003	TORSION SPRING	PINCH ROLLER ARM(1
	36	VKZ4035-009	WASHER	FOR OIL CUT(F)	1
	37	Q03093-527	WASHER	FOR OIL CUT(R)	1
	41	SDSF2608Z	SCREW		1
	42	VKS5327-003	THRUST PLATE		1
	45	VKM3416-004	FM BRACKET		1
	47	SDSF2605Z	SCREW	FM BRACKET	2
	48	MMI-6H2LWK	MOTOR ASS'Y	FOR CAPSTAN	1
	49	VKR4364-002	MOTOR PULLEY		1
	50	SPSP2603Z	SCREW		2
	51	VKS3485-002	HEAD GEAR (1)		1
	52	VKY4628-001	PACK SPRING		1

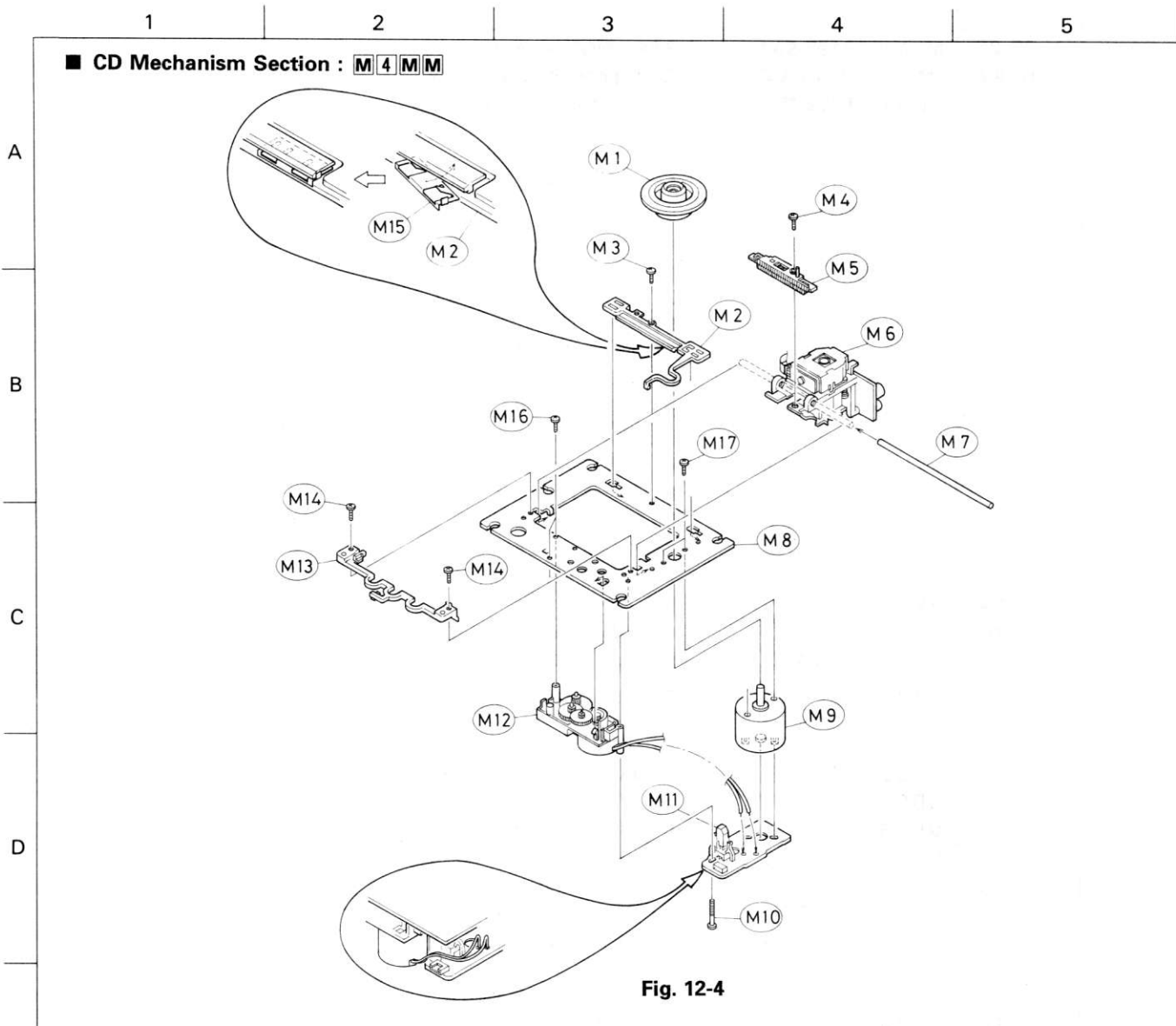
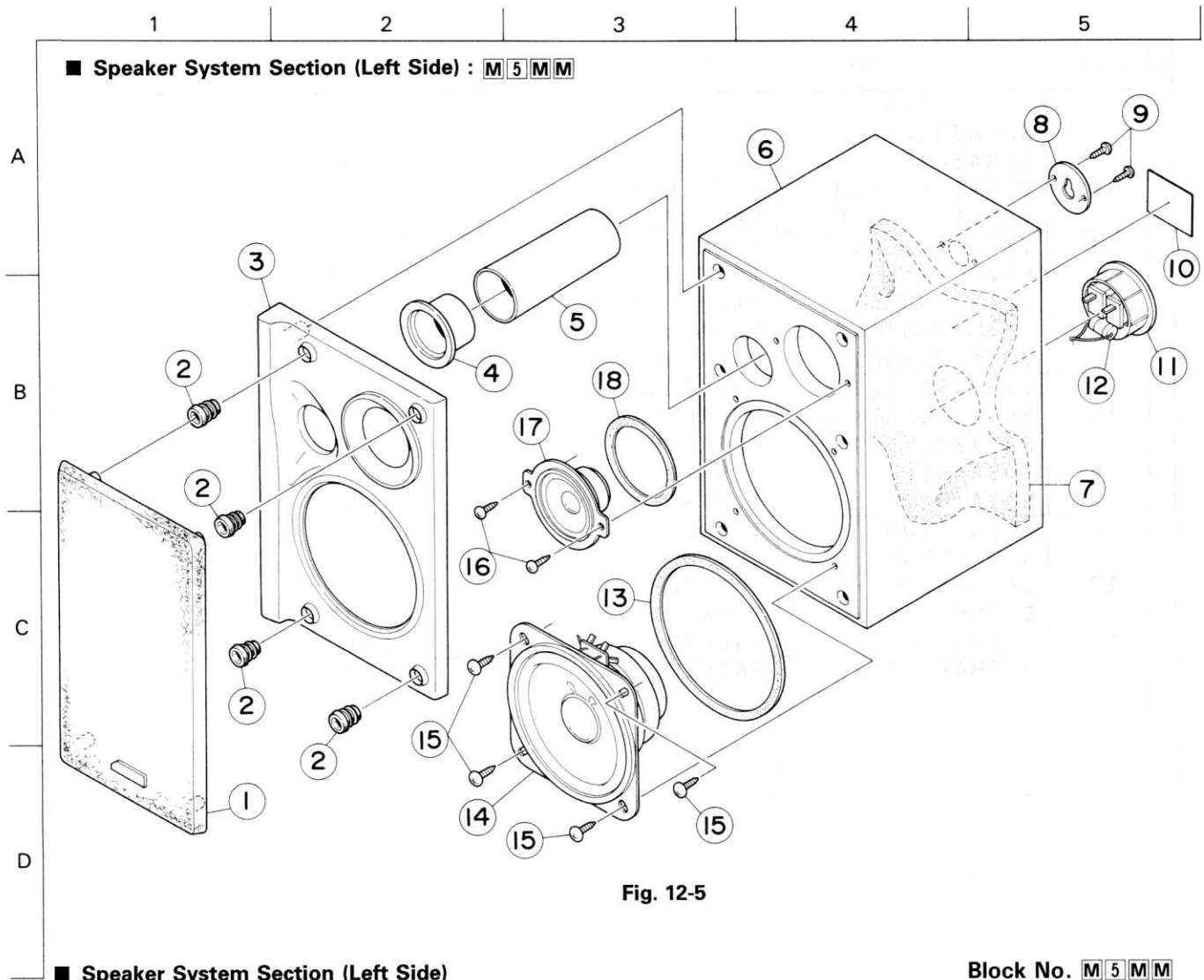

Fig. 12-4

CD Mechanism Component Parts List

Block No. M4MM

REF. NO.	PARTS NO.	PARTS NAME	REMARKS	Q'TY
M1	E406064-002	CD TURN TABLE ASS'Y		1
M2	E306275-003	CD SUPPORT		1
M3	SDST2005Z	SCREW	FOR CD SUPPORT	1
M4	SPSH2050M	SCREW	FOR CD RACK ASS'Y	1
M5	E306282-001	CD RACK ASS'Y		1
M6	OPTIMA-5S	CD PICK UP UNIT		1
M7	E74930-003	CD SHAFT	FOR CD PICK UP UNIT	1
M8	E26487-003	CD MECHANISM BASE		1
M9	E74539-001B	SPINDLE MOTOR		1
M10	E75832-001	SCREW	FOR CD LEAF SWITCH UNIT	1
M11	ESB1100-005	CD LEAF SWITCH		1
M12	SE10351-11	CD GEAR ASS'Y		1
M13	E306277-001	CD HOLDER		1
M14	SDST2004Z	SCREW	FOR CD HOLDER	2
M15	E75827-001	SPRING	FOR CD SUPPORT	1
M16	E72713-001	SCREW	FOR CD MECHA BASE + GEAR ASS'Y	2
M17	SDSP2003N	SCREW	FOR SPINDLE MOTOR	2



△	REF.	PARTS NO.	PARTS NAME	REMARKS	QTY
	3,6	VJC2414-001SA	SPEAKER BOX ASS'Y	LEFT	1
	3,6	VJC2414-002SA	SPEAKER BOX ASS'Y	RIGHT	1
	1	VJC2413-10A	GRILL ASS'Y	LEFT	1
		VJC2413-10B	GRILL ASS'Y	RIGHT	1
	2	VYTR430-001	BLIND	LEFT	4
		VYTR430-001	BLIND	RIGHT	4
	3	VJC1970-003	FRONT PANEL	LEFT	1
		VJC1971-003	FRONT PANEL	RIGHT	1
	4	VYH7369-001	DUCT CONECTOR	LEFT	1
		VYH7369-001	DUCT CONECTOR	RIGHT	1
	5	VYH7370-001	DUCT	LEFT	1
		VYH7370-001	DUCT	RIGHT	1
	6	VJC2414-003	SPEAKER BOX	LEFT	1
		VJC2414-004	SPEAKER BOX	RIGHT	1
	7	VKZ4389-002	SOUND ABSOBER	LEFT	1
		VKZ4389-002	SOUND ABSOBER	RIGHT	1
	8	VJD5342-001	HOLDER	LEFT	1

△	REF.	PARTS NO.	PARTS NAME	REMARKS	QTY
	9	VJD5342-001	HOLDER	RIGHT	1
		SDSA3012M	SCREW	LEFT	2
		SDSA3012M	SCREW	RIGHT	2
	10	VYN9159-101B	NAME PLATE	LEFT	1
		VYN9159-101B	NAME PLATE	RIGHT	1
	11	VMZ0099-001	TERMINAL	LEFT	1
		VMZ0099-001	TERMINAL	RIGHT	1
	12	UXB1-CONDENSER	E.CAPACITOR	LEFT NETWORK,1.5	1
		UXB1-CONDENSER	E.CAPACITOR	RIGHT NETWORK,1.5	1
	13	VYTH490-001	PACKING	LEFT	1
	14	VYTH490-001	PACKING	RIGHT	1
		EAS12PL511K-G	SPEAKER	LEFT	1
		EAS12PL511K-G	SPEAKER	RIGHT	1
	15	SDSA4012M	T.SCREW	FOR LEFT SPEAKER	4
		SDSA4012M	T.SCREW	RIGHT	4
	16	SDSA3510M	SCREW	LEFT	2
		SDSA3510M	SCREW	RIGHT	2
	17	EAS5PH73KA-G	SPEAKER	LEFT	1
		EAS5PH73KA-G	SPEAKER	RIGHT	1
	18	VYTH490-002	PACKING	LEFT	1
		VYTH490-002	PACKING	RIGHT	1

13 Illustration of Packing and Packing Parts List

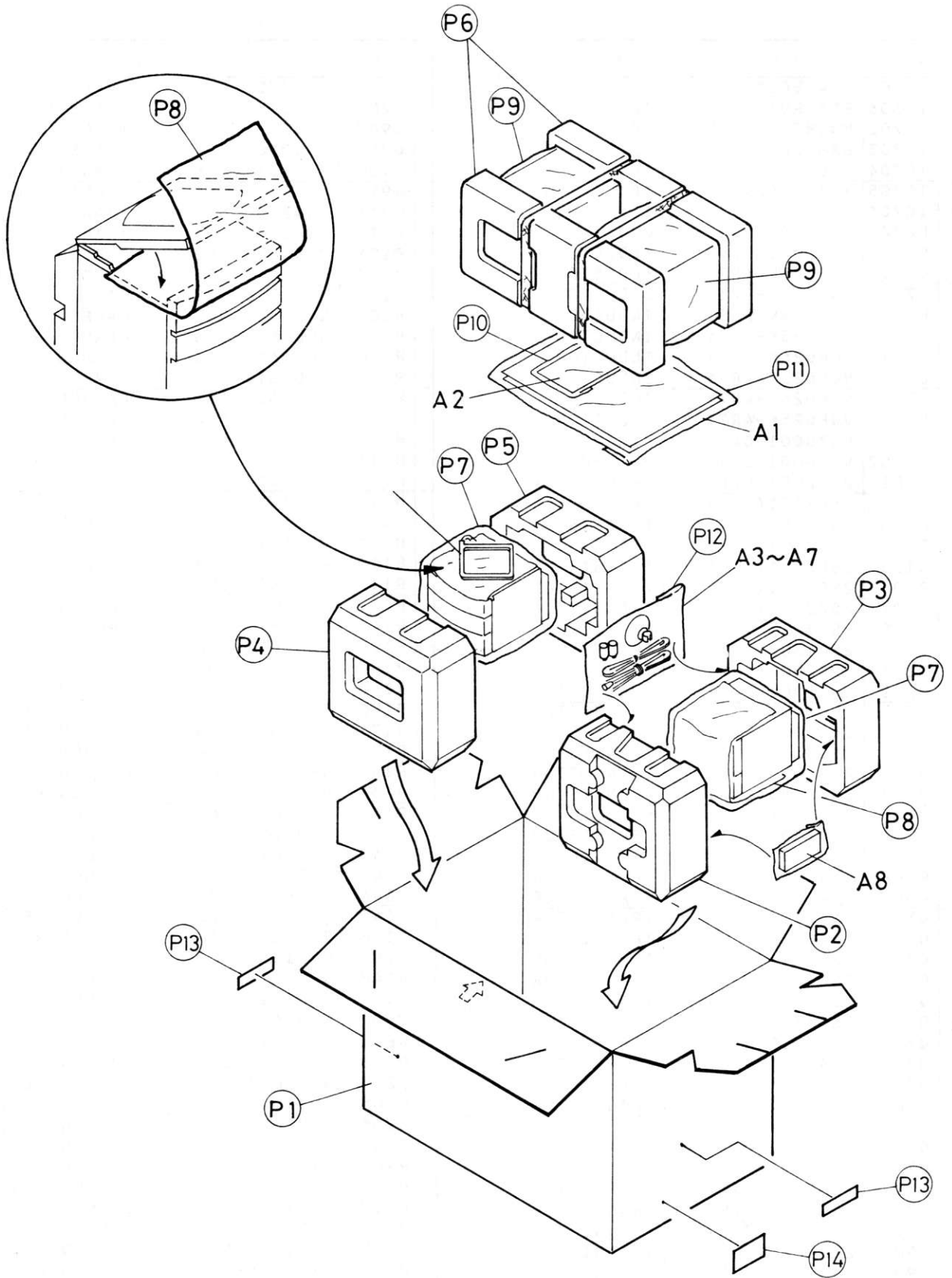

Fig. 13-1

■ Packing & Accessories Parts List

REF. NO.	PARTS NO.	PARTS NAME	REMARKS	Q'TY
P1	VPC9159-006	CARTON		1
P2	VPH1538-001	CUSHION (F1)	TAPE DECK SECTION: FRONT	1
P3	VPH1538-002	CUSHION (R1)	TAPE DECK SECTION: REAR	1
P4	VPH1539-001	CUSHION (F2)	CD PLAYER SECTION: FRONT	1
P5	VPH1539-002	CUSHION (R2)	CD PLAYER SECTION: REAR	1
P6	VPH3216-001	CUSHION SET	FOR SPEAKER SYSTEM	1 set
P7	VPE3005-065	ENVELOPE	TAPE DECK/CD PLAYER SECTIONS	2
P8	VPK4002-009	SHEET	TAPE DECK/CD PLAYER SECTIONS	2
P9	VPE3010-007	ENVELOPE	FOR SPEAKER SYSTEM	2
P10	E66416-003	ENVELOPE	FOR INSTRUCTIONS BOOK, WARRANTY CARD	1
P11	VPE3005-007	ENVELOPE	INSTRUCTIONS BOOK, WARRANTY CARD	1
P12	QPGA010-03003	ENVELOPE	FOR ACCESSORIES A3 – A6	1
P13	VND3044-003	SERIAL TICKET	UX-1E	1
	VND3044-004	SERIAL TICKET	UX-1B	1
	VND3044-005	SERIAL TICKET	UX-1G	1
P14	VND3025-127	EAN CODE LABEL		1
A1	VNN9159-211	INSTRUCTIONS	UX-1B/E/G	1
	VNN9159-441	INSTRUCTIONS	UX-1E	1
A2	PU36158	FTZ INFORMATION SHEET	UX-1G	1
	BT20066A	WARRANTY CARD	UX-1B/G	1
	BT20114	SAFETY CARD	UX-1G	1
	BT20060	SAFETY CARD	UX-1B	1
	E43486-340B	SAFETY INSTRUCTION SHEET	UX-1B	1
A3	EWP502-001	FM ANTENNA		1
A4	E304084-001	LOOP ANTENNA STAND		1
A5	VMP0093-002	SPEAKER CORD		2
A6	UM4NJ-2P	BATTERY	FOR REMOCON UNIT	2
A7	UGZ0112-001	CHANGE PLUG		1
A8	RM955	REMOCON UNIT	MODEL NAME: RM-RX1001	1

14 Electrical Parts List

■ Micro Computer/LCD Display/Function
P.C.Board : Drawing No.VMW1255

△	REF.	PARTS NO.	PARTS NAME
	CN301	VMC0063-010	CONNECTOR
	CN302	VMC0162-013	CONNECTOR
	CN303	VMC0162-013	CONNECTOR
	CN701	VMC0064-002	CONNECTOR
	CN702	VMC0064-006	CONNECTOR
	CN703	VMC0162-R13	CONNECTOR
	CN704	VMC0162-R13	CONNECTOR
	CN705	VMC0107-R05	SOCKET
	CN706	VMC0063-006	CONNECTOR
	CN707	VMC0162-010	CONNECTOR
	C100	QCS11HJ-330	C CAPACITOR
	C101	QEK41HM-225	E.CAPA.
	C102	QEK41CM-106	E CAPACITOR
	C105	QEK41HM-105	E CAPACITOR
	C106	QCXB1CM-562Y	C CAPACITOR
	C107	QCS11HJ-330	C CAPACITOR
	C108	QFV41HJ-224	TF CAPACITOR
	C109	QFV41HJ-683	TF CAPACITOR
	C110	QEK41HM-105	E CAPACITOR
	C111	QEK41EM-475	E.CAPACITOR
	C112	QCS11HJ-330	C CAPACITOR
	C113	QEK41CM-226	E CAPACITOR
	C114	QEK41HM-105	E CAPACITOR
	C115	QFV11HJ-393ZM	TF CAPACITOR
	C200	QCS11HJ-330	C CAPACITOR
	C201	QEK41HM-225	E.CAPA.
	C202	QEK41CM-106	E CAPACITOR
	C205	QEK41HM-105	E CAPACITOR
	C206	QCXB1CM-562Y	C CAPACITOR
	C207	QCS11HJ-330	C CAPACITOR
	C208	QFV41HJ-224	TF CAPACITOR
	C209	QFV41HJ-683	TF CAPACITOR
	C210	QEK41HM-105	E CAPACITOR
	C211	QEK41EM-475	E.CAPACITOR
	C212	QCS11HJ-330	C CAPACITOR
	C213	QEK41CM-226	E CAPACITOR
	C214	QEK41HM-105	E CAPACITOR
	C215	QFV11HJ-393ZM	TF CAPACITOR
	C301	QEK41CM-336	E CAPACITOR
	C302	QEK41EM-475	E.CAPACITOR
	C303	QEK41CM-476	E CAPACITOR
	C304	QEK41CM-336	E CAPACITOR
	C313	QEK41CM-476	E CAPACITOR
	C314	QEK41CM-336	E CAPACITOR
	C315	QEK41EM-335	E CAPACITOR
	C316	QEK41CM-476	E CAPACITOR
	C317	QCC11EM-103	C CAPACITOR
	C318	QEK41HM-105	E CAPACITOR
	C701	QCBB1HK-102Y	C CAPACITOR
	C702	QETC1AM-107ZN	E CAPACITOR
	C703	VCE0056-479Z	SUPER CAP.
	C707	QCBB1HK-102Y	C CAPACITOR
	C709	QCS11HJ-200	C CAPACITOR
	C710	QCS11HJ-160	C CAPACITOR
	C711	QCS11HJ-220	C CAPACITOR
	C712	QCS11HJ-220	C CAPACITOR
	C713	QCS11HJ-560	C.CAPACITOR
	C714	QCS11HJ-560	C.CAPACITOR
	C715	QCBB1HK-151Y	C CAPACITOR
	C716	QETC1HM-104ZM	E CAPACITOR

△	REF.	PARTS NO.	PARTS NAME
	C717	QETC1HM-225ZM	E.CAPACITOR
	C719	QETC1AM-107ZM	E.CAPACITOR
	C720	QETC1AM-227ZM	E.CAPACITOR
	C722	QETC1HM-105ZN	E CAPACITOR
	C723	QETC1HM-105ZN	E CAPACITOR
	C724	QETC1HM-475ZN	E CAPACITOR
	C725	QETC1HM-475ZN	E CAPACITOR
	C726	QETC1AM-476ZN	E CAPACITOR
	C727	QCC11EM-473	E CAPACITOR
	C729	QETC1AM-476ZN	E CAPACITOR
	C730	QCBB1HK-102Y	C CAPACITOR
	C731	QCBB1HK-102Y	C CAPACITOR
	C732	QCBB1HK-102Y	C CAPACITOR
	C733	QCBB1HK-102Y	C CAPACITOR
	C734	QCBB1HK-102Y	C CAPACITOR
	C735	QCXB1CM-472Y	C.CAPACITOR
	C901	QFV41HJ-683	TF CAPACITOR
	C902	QFV41HJ-683	TF CAPACITOR
	C903	QFV41HJ-683	TF CAPACITOR
	C904	QFV41HJ-683	TF CAPACITOR
	C905	QETB1EM-228N	E.CAPACITOR
	C906	QFV41HJ-683	TF CAPACITOR
	C907	QFV41HJ-683	TF CAPACITOR
	C908	QCBB1HK-102Y	C CAPACITOR
	C909	QCVB1CM-103Y	C CAPACITOR
	C910	QEK41CM-476	E CAPACITOR
	C911	QEK61AM-107ZM	E CAPACITOR
	C912	QCBB1HK-102Y	C CAPACITOR
	C913	QEK61AM-107ZM	E CAPACITOR
	C914	QCBB1HK-102Y	C CAPACITOR
	C915	QEK41CM-476	E CAPACITOR
	C916	QEK41CM-476	E CAPACITOR
	D301	MA165	SI DIODE
	D302	MA165	SI DIODE
	D303	MA165	SI DIODE
	D304	MA165	SI DIODE
	D305	MA165	SI DIODE
	D306	MA165	SI DIODE
	D703	MA165	SI DIODE
	D704	MA165	SI DIODE
	D706	MA4062(H)	Z DIODE
	D708	11E1-TB2	SI DIODE
	D709	MA165	SI DIODE
	D711	MA165	SI DIODE
	D712	MA165	SI DIODE
	D713	MA165	SI DIODE
	D901	S4VB10-4002	SI DIODE
	D902	MA165	SI DIODE
	D903	MA4056(M)	ZENER DIODE
	D904	MA165	SI DIODE
	D905	MA165	SI DIODE
	D906	MA165	SI DIODE
	D907	MA4068(M)	Z DIODE
	D908	MA4062(H)	Z DIODE
	D909	MA165	SI DIODE
	D910	MA165	SI DIODE
	D911	MA165	SI DIODE
	IC301	VC4580L	IC
	IC303	XRA15218N	IC
	IC304	VC4580L	IC

△	REF.	PARTS NO.	PARTS NAME
	IC305	VC4580LD	IC
	IC306	PQ30RV1	IC
	IC702	MN1871610JCK-1	IC(CPU)
	IC703	BA6208A	IC
	IC704	TA8409S	IC
	IC705	XRA10358N	IC
	IC706	PST529C	IC
	LC701	VGL1089-102	LCD
	L702	VQZ0048-009	INDUCTOR
	L703	VQP025K-4R7Y	INDUCTOR
	L704	VQP025K-221Y	INDUCTOR
	L705	VQP025K-221Y	INDUCTOR
	L710	VQP025K-4R7Y	INDUCTOR
	L711	VQP025K-4R7Y	INDUCTOR
	L712	VQP025K-4R7Y	INDUCTOR
	L713	VQP025K-4R7Y	INDUCTOR
	L714	VQP025K-4R7Y	INDUCTOR
	PL701	VGZ0001-041	P.LAMP
	PL702	VGZ0001-041	P.LAMP
	Q101	2SC2001(L,K)	TRANSISTOR
	Q102	2SC2001(L,K)	TRANSISTOR
	Q103	2SC2001(L,K)	TRANSISTOR
	Q104	2SC2001(L,K)	TRANSISTOR
	Q105	2SC2001(L,K)	TRANSISTOR
	Q106	2SC2001(L,K)	TRANSISTOR
	Q107	2SC2785(E,F)	TRANSISTOR
	Q108	2SK301(P,Q)	FET I/M
	Q109	2SD1302(S,T)	TRANSISTOR
	Q201	2SC2001(L,K)	TRANSISTOR
	Q202	2SC2001(L,K)	TRANSISTOR
	Q203	2SC2001(L,K)	TRANSISTOR
	Q204	2SC2001(L,K)	TRANSISTOR
	Q205	2SC2001(L,K)	TRANSISTOR
	Q206	2SC2001(L,K)	TRANSISTOR
	Q207	2SC2785(E,F)	TRANSISTOR
	Q208	2SK301(P,Q)	FET I/M
	Q209	2SD1302(S,T)	TRANSISTOR
	Q301	UN411E	TRANSISTOR
	Q302	UN411E	TRANSISTOR
	Q303	UN411E	TRANSISTOR
	Q304	UN4210	TRANSISTOR
	Q308	UN4111	TRANSISTOR
	Q701	2SC3311(R,S)	TRANSISTOR
	Q702	2SC945L(P,Q)	TRANSISTOR
	Q703	2SC945L(P,Q)	TRANSISTOR
	Q705	2SC3311(R,S)	TRANSISTOR
	Q706	2SC3311(R,S)	TRANSISTOR
	Q707	2SA952(L,K)	TRANSISTOR
	Q708	UN4211	TRANSISTOR
	Q709	2SB562(B,C)	TRANSISTOR
	Q710	2SC3311(R,S)	TRANSISTOR
	Q711	2SC3311(R,S)	TRANSISTOR
	Q712	2SA733A(P,K)	TRANSISTOR
	Q713	2SA733A(P,K)	TRANSISTOR
	Q714	2SC3311(R,S)	TRANSISTOR
	Q715	2SC3311(R,S)	TRANSISTOR
	Q901	2SB562(B,C)	TRANSISTOR
	Q902	2SB562(B,C)	TRANSISTOR
	Q903	2SB562(B,C)	TRANSISTOR
	Q904	2SC2785(E,F)	TRANSISTOR

△	REF.	PARTS NO.	PARTS NAME
	Q905	2SC2785(E,F)	TRANSISTOR
	Q906	UN411E	TRANSISTOR
	Q907	UN4213	TRANSISTOR
	Q908	UN4210	TRANSISTOR
	Q909	2SC3311(R,S)	TRANSISTOR
	Q910	UN4213	TRANSISTOR
	Q911	UN4213	TRANSISTOR
	Q912	UN4210	TRANSISTOR
	R101	QRD161J-682	CARBON RESISTOR
	R102	QRD161J-103	CARBON RESISTOR
	R103	QRD161J-123	CARBON RESISTOR
	R104	QRD161J-822	CARBON RESISTOR
	R105	QRD161J-103	CARBON RESISTOR
	R106	QRD161J-473	CARBON RESISTOR
	R107	QRD161J-333	CARBON RESISTOR
	R108	QRD161J-683	CARBON RESISTOR
	R109	QRD161J-102	CARBON RESISTOR
	R110	QRD161J-472	CARBON RESISTOR
	R111	QRD161J-472	CARBON RESISTOR
	R112	QRD161J-472	CARBON RESISTOR
	R113	QRD161J-472	CARBON RESISTOR
	R114	QRD161J-472	CARBON RESISTOR
	R115	QRD161J-224	CARBON RESISTOR
	R116	QRD161J-823	CARBON RESISTOR
	R117	QRD161J-101	CARBON RESISTOR
	R118	QRD161J-223	CARBON RESISTOR
	R119	QRD161J-153	CARBON RESISTOR
	R121	QRD161J-472	CARBON RESISTOR
	R127	QRD161J-103	CARBON RESISTOR
	R129	QRD161J-152	CARBON RESISTOR
	R130	QRD161J-103	CARBON RESISTOR
	R131	QRD161J-103	CARBON RESISTOR
	R132	QRD161J-222	CARBON RESISTOR
	R133	QRD161J-683	CARBON RESISTOR
	R134	QRD161J-102	CARBON RESISTOR
	R140	QRD161J-562	CARBON RESISTOR
	R141	QRD161J-103	CARBON RESISTOR
	R142	QRD161J-153	CARBON RESISTOR
	R143	QRD161J-104	CARBON RESISTOR
	R144	QRD161J-470	CARBON RESISTOR
	R145	QRD161J-105	CARBON RESISTOR
	R146	QRD161J-104	CARBON RESISTOR
	R147	QRD161J-102	CARBON RESISTOR
	R148	QRD161J-681	CARBON RESISTOR
	R149	QRD161J-334	CARBON RESISTOR
	R201	QRD161J-682	CARBON RESISTOR
	R202	QRD161J-103	CARBON RESISTOR
	R203	QRD161J-123	CARBON RESISTOR
	R204	QRD161J-822	CARBON RESISTOR
	R205	QRD161J-103	CARBON RESISTOR
	R206	QRD161J-473	CARBON RESISTOR
	R207	QRD161J-333	CARBON RESISTOR
	R208	QRD161J-683	CARBON RESISTOR
	R209	QRD161J-102	CARBON RESISTOR
	R210	QRD161J-472	CARBON RESISTOR
	R211	QRD161J-472	CARBON RESISTOR
	R212	QRD161J-472	CARBON RESISTOR
	R213	QRD161J-472	CARBON RESISTOR
	R214	QRD161J-472	CARBON RESISTOR
	R215	QRD161J-224	CARBON RESISTOR

△	REF.	PARTS NO.	PARTS NAME
	R216	QRD161J-823	CARBON RESISTOR
	R217	QRD161J-101	CARBON RESISTOR
	R218	QRD161J-223	CARBON RESISTOR
	R219	QRD161J-153	CARBON RESISTOR
	R221	QRD161J-472	CARBON RESISTOR
	R227	QRD161J-103	CARBON RESISTOR
	R229	QRD161J-152	CARBON RESISTOR
	R230	QRD161J-103	CARBON RESISTOR
	R231	QRD161J-103	CARBON RESISTOR
	R232	QRD161J-222	CARBON RESISTOR
	R233	QRD161J-683	CARBON RESISTOR
	R234	QRD161J-102	CARBON RESISTOR
	R240	QRD161J-562	CARBON RESISTOR
	R241	QRD161J-103	CARBON RESISTOR
	R242	QRD161J-153	CARBON RESISTOR
	R243	QRD161J-104	CARBON RESISTOR
	R244	QRD161J-470	CARBON RESISTOR
	R245	QRD161J-105	CARBON RESISTOR
	R246	QRD161J-104	CARBON RESISTOR
	R247	QRD161J-102	CARBON RESISTOR
	R248	QRD161J-681	CARBON RESISTOR
	R249	QRD161J-334	CARBON RESISTOR
	R301	QRD161J-102	CARBON RESISTOR
	R302	QRD161J-102	CARBON RESISTOR
	R303	QRD161J-102	CARBON RESISTOR
	R304	QRD161J-223	CARBON RESISTOR
	R305	QRD161J-223	CARBON RESISTOR
	R306	QRD161J-103	CARBON RESISTOR
	R307	QRD161J-121	CARBON RESISTOR
	R313	QRD161J-103	CARBON RESISTOR
	R314	QRD161J-121	CARBON RESISTOR
	R316	QRD161J-103	CARBON RESISTOR
	R317	QRD161J-2R2	CARBON RESISTOR
	R318	QRD161J-223	CARBON RESISTOR
	R721	QRD161J-103	CARBON RESISTOR
	R722	QRD161J-103	CARBON RESISTOR
	R723	QRD161J-103	CARBON RESISTOR
	R724	QRD161J-682	CARBON RESISTOR
	R725	QRD161J-103	CARBON RESISTOR
	R726	QRD161J-103	CARBON RESISTOR
	R727	QRD161J-103	CARBON RESISTOR
	R728	QRD161J-103	CARBON RESISTOR
	R729	QRD161J-103	CARBON RESISTOR
	R730	QRD161J-103	CARBON RESISTOR
	R731	QRD161J-103	CARBON RESISTOR
	R732	QRD161J-102	CARBON RESISTOR
	R733	QRD161J-223	CARBON RESISTOR
	R735	QRD161J-223	CARBON RESISTOR
	R736	QRD161J-223	CARBON RESISTOR
	R737	QRD161J-102	CARBON RESISTOR
	R738	QRD161J-102	CARBON RESISTOR
	R739	QRD161J-102	CARBON RESISTOR
	R740	QRD161J-103	CARBON RESISTOR
	R741	QRD161J-102	CARBON RESISTOR
	R742	QRD161J-102	CARBON RESISTOR
	R743	QRD161J-102	CARBON RESISTOR
	R744	QRD161J-102	CARBON RESISTOR
	R745	QRD161J-102	CARBON RESISTOR
	R746	QRD161J-102	CARBON RESISTOR
	R747	QRD161J-102	CARBON RESISTOR

△	REF.	PARTS NO.	PARTS NAME
	R748	QRD161J-103	CARBON RESISTOR
	R749	QRD161J-103	CARBON RESISTOR
	R750	QRD161J-103	CARBON RESISTOR
	R751	QRD161J-102	CARBON RESISTOR
	R752	QRD161J-102	CARBON RESISTOR
	R753	QRD161J-102	CARBON RESISTOR
	R754	QRD161J-102	CARBON RESISTOR
	R756	QRD161J-473	CARBON RESISTOR
	R758	QRD161J-473	CARBON RESISTOR
	R759	QRD161J-104	CARBON RESISTOR
	R760	QRD161J-473	CARBON RESISTOR
	R762	QRD161J-221	CARBON RESISTOR
	R764	QRD161J-221	CARBON RESISTOR
	R765	QRD161J-472	CARBON RESISTOR
	R766	QRD161J-272	CARBON RESISTOR
	R767	QRD161J-332	CARBON RESISTOR
	R768	QRD161J-332	CARBON RESISTOR
	R769	QRD161J-473	CARBON RESISTOR
	R770	QRD161J-473	CARBON RESISTOR
	R771	QRD161J-474	CARBON RESISTOR
	R772	QRD161J-474	CARBON RESISTOR
	R773	QRD161J-183	CARBON RESISTOR
	R774	QRD161J-183	CARBON RESISTOR
	R775	QRD161J-473	CARBON RESISTOR
	R776	QRD161J-473	CARBON RESISTOR
	R777	QRD161J-472	CARBON RESISTOR
	R778	QRD161J-472	CARBON RESISTOR
	R779	QRD161J-331	CARBON RESISTOR
	R781	QRD161J-102	CARBON RESISTOR
	R782	QRD161J-471	CARBON RESISTOR
	R785	QRD161J-102	CARBON RESISTOR
	R786	QRD161J-104	CARBON RESISTOR
	R787	QRD161J-4R7	CARBON RESISTOR
	R788	QRD121J-2R2	CARBON RESISTOR
	R790	QRD161J-104	CARBON RESISTOR
	R791	QRD161J-102	CARBON RESISTOR
	R792	QRD161J-683	CARBON RESISTOR
	R793	QRD161J-683	CARBON RESISTOR
	R794	QRD161J-103	CARBON RESISTOR
	R795	QRD161J-221	CARBON RESISTOR
	R797	QRD161J-103	CARBON RESISTOR
	R798	QRD161J-104	CARBON RESISTOR
	R800	QRD161J-821	CARBON RESISTOR
	R801	QRD161J-473	CARBON RESISTOR
	R802	QRD161J-102	CARBON RESISTOR
	R803	QRD161J-102	CARBON RESISTOR
	R804	QRD161J-223	CARBON RESISTOR
	R805	QRD161J-223	CARBON RESISTOR
	R806	QRD161J-472	CARBON RESISTOR
	R807	QRD161J-472	CARBON RESISTOR
	R808	QRD161J-102	CARBON RESISTOR
	R810	QRD161J-222	CARBON RESISTOR
	R811	QRD161J-222	CARBON RESISTOR
	R901	QRD143J-4R7S	CARBON RESISTOR
	R902	QRD143J-4R7S	CARBON RESISTOR
	R903	QRD143J-4R7S	CARBON RESISTOR
	R904	QRD161J-224	CARBON RESISTOR
	R905	QRD161J-224	CARBON RESISTOR
	R906	QRD161J-471	CARBON RESISTOR
	R907	QRD161J-563	CARBON RESISTOR

■ CD Control P.C.Board
:Drawing No.VMW2307

△	REF.	PARTS NO.	PARTS NAME
	R908	QRD161J-103	CARBON RESISTOR
	R909	QRD161J-151	CARBON RESISTOR
	R910	QRD161J-681	CARBON RESISTOR
	R911	QRD161J-182	CARBON RESISTOR
	R912	QRD161J-472	CARBON RESISTOR
	R913	QRD161J-223	CARBON RESISTOR
	R914	QRD161J-683	CARBON RESISTOR
	R915	QRD161J-122	CARBON RESISTOR
	R916	QRD161J-103	CARBON RESISTOR
	R917	QRD161J-222	CARBON RESISTOR
	R918	QRD161J-332	CARBON RESISTOR
	R919	QRD161J-102	CARBON RESISTOR
	R920	QRD12CJ-470SX	C RESISTOR
	R921	QRD161J-472	CARBON RESISTOR
	R922	QRD161J-101	CARBON RESISTOR
	R923	QRD161J-221	CARBON RESISTOR
	R924	QRD161J-104	CARBON RESISTOR
	R927	QRD161J-101	CARBON RESISTOR
	R928	QRD161J-101	CARBON RESISTOR
	R929	QRD161J-101	CARBON RESISTOR
	R930	QRD161J-101	CARBON RESISTOR
	R931	QRD161J-333	CARBON RESISTOR
	R932	QRD161J-331	CARBON RESISTOR
	S715	QSS7A23-V06	SLIDE SWITCH
	T301	EQF0101-002	FILTER
	X701	VCX5000-001	CRYSTAL
	X702	CSA8.00MT-TF01	CERA LOCK

■ CD Door Open/Close Switch·Door Moter
Antenna Terminal·Auxjack·Leaf Switch
P.C.Board : Drawing No.VMW1253A~E

△	REF.	PARTS NO.	PARTS NAME
	B1	E03719-15.0	FORMED BUS WIRE
	CN306	VMC0063-003	CONNECTOR
	CN708	VMC0063-002	CONNECTOR
	J301	VMJ3009-001	JACK ASSY
	S717	QSP2K21-V01	PUSH SWITCH
	S718	QSP2K21-V01	PUSH SWITCH
	S751	VSH1140-003	LEAF SWITCH
	S752	VSH1140-003	LEAF SWITCH
	S753	VSH1140-003	LEAF SWITCH
	S754	VSH1140-003	LEAF SWITCH
	S755	VSH1140-003	LEAF SWITCH

△	REF.	PARTS NO.	PARTS NAME
	CN504	VMC0162-010	CONNECTOR
	C502	QETC1AM-476ZN	E CAPACITOR
	C505	QCBB1HK-471Y	C CAPACITOR
	C506	QCC11EM-223	C CAPACITOR
	C507	QCS11HJ-680	C CAPACITOR
	C508	QETC1AM-476ZN	E CAPACITOR
	C509	QCS11HJ-680	C CAPACITOR
	C510	QCSB1HK-2R2Y	C CAPACITOR
	C511	QCC11EM-223	C CAPACITOR
	C512	QCS11HJ-220	C CAPACITOR
	C513	QCBB1HK-820Y	C CAPACITOR
	C514	QCVB1CM-103Y	C CAPACITOR
	C515	QCC11EM-473	C CAPACITOR
	C516	QCS11HJ-470	C CAPACITOR
	C517	QCBB1HK-151Y	C CAPACITOR
	C518	QCBB1HK-101Y	C CAPACITOR
	C519	QCS11HJ-330	C CAPACITOR
	C520	QCXB1CM-222Y	C CAPACITOR
	C521	QEK41CM-476	E CAPACITOR
	C522	QCBB1HK-221Y	C CAPACITOR
	C523	QCBB1HK-221Y	C CAPACITOR
	C525	QER41EM-475	E CAPACITOR
	C526	QER61AM-476ZM	E CAPACITOR
	C527	QEPJ1HM-105ZM	NP CAPACITOR
	C528	QFV41HJ-123	TF CAPACITOR
	C529	QFV11HJ-273ZN	TF CAPACITOR
	C531	QCVB1CM-822Y	C CAPACITOR
	C535	QFV41HJ-224	TF CAPACITOR
	C544	QCS11HJ-100	C CAPACITOR
	C545	QCS11HJ-100	C CAPACITOR
	C547	QFV41HJ-473	TF CAPACITOR
	C548	QETC1AM-476ZN	E CAPACITOR
	C549	QCC11EM-473	C CAPACITOR
	C550	QCBB1HK-331Y	C CAPACITOR
	C551	QETC1AM-476ZN	E CAPACITOR
	C552	QETC1AM-476ZN	E CAPACITOR
	C553	QCY41HK-122	C CAPACITOR
	C554	QETC1EM-106ZN	E CAPACITOR
	C555	QCY41HK-122	C CAPACITOR
	C556	QETC1AM-476ZN	E CAPACITOR
	C557	QCBB1HK-331Y	C CAPACITOR
	C563	QFV41HJ-123	FILM CAPACITOR
	C587	QCS11HJ-470	C CAPACITOR
	C591	QCC11EM-223	C CAPACITOR
	C604	QETC1EM-226ZN	E CAPACITOR
	C605	QETC1EM-226ZN	E CAPACITOR
	C606	QCXB1CM-562Y	C CAPACITOR
	C607	QCXB1CM-562Y	C CAPACITOR
	C608	QCXB1CM-682Y	C CAPACITOR
	C609	QCXB1CM-682Y	C CAPACITOR
	C610	QCS11HJ-680	C CAPACITOR
	C611	QCS11HJ-680	C CAPACITOR
	C612	QETC1EM-226ZN	E CAPACITOR
	C613	QETC1EM-226ZN	E CAPACITOR
	C614	QCC11EM-123	C CAPACITOR
	C615	QCC11EM-123	C CAPACITOR
	C616	QETC1AM-107ZN	E CAPACITOR
	C617	QETC1AM-107ZN	E CAPACITOR
	C618	QCC11EM-223	C CAPACITOR

△	REF.	PARTS NO.	PARTS NAME
	C620	QEK61AM-107ZM	E CAPACITOR
	C621	QETC1AM-477ZN	E CAPACITOR
	C623	QETC1AM-476ZN	E CAPACITOR
	D610	RD5.6ES	DIODE
	IC501	MC13501M	IC
	IC502	NJM3403D-C	IC
	IC503	BA6294	IC
	IC504	BA6294	IC
	IC602	TC9201BF	IC
	IC603	TC9200BF	IC
	IC604	CXK5816PS-15L	IC
	IC605	TD6710AF	IC
	IC607	XRA15218N	IC
	Q501	2SA1309(R,S)	TRANSISTOR
	Q503	2SC1685(Q,R)	TRANSISTOR
	Q504	2SC1685(Q,R)	TRANSISTOR
	Q505	2SA1309(R,S)	TRANSISTOR
	Q614	2SD1302(S,T)	TRANSISTOR
	R501	QRD161J-184	CARBON RESISTOR
	R502	QRD161J-154	CARBON RESISTOR
	R503	QRD161J-682	CARBON RESISTOR
	R504	QRD161J-472	CARBON RESISTOR
	R505	QRD161J-102	CARBON RESISTOR
	R506	QRD161J-681	CARBON RESISTOR
	R507	QRD161J-104	CARBON RESISTOR
	R508	QRD161J-273	CARBON RESISTOR
	R509	QRD161J-222	CARBON RESISTOR
	R510	QRD161J-103	CARBON RESISTOR
	R511	QRD161J-103	CARBON RESISTOR
	R512	QRD161J-123	CARBON RESISTOR
	R513	QRD161J-103	CARBON RESISTOR
	R514	QRD161J-224	CARBON RESISTOR
	R515	QRD161J-333	CARBON RESISTOR
	R516	QRD161J-153	CARBON RESISTOR
	R517	QRD161J-822	CARBON RESISTOR
	R519	QRD161J-823	CARBON RESISTOR
	R520	QRV141F-3302AY	CMF RESISTOR
	R521	QRD161J-823	CARBON RESISTOR
	R522	QRD161J-102	CARBON RESISTOR
	R523	QRD161J-562	CARBON RESISTOR
	R524	QRD161J-152	CARBON RESISTOR
	R525	QRD161J-273	CARBON RESISTOR
	R526	QRD161J-682	CARBON RESISTOR
	R527	QRD161J-564	CARBON RESISTOR
	R528	QRD161J-153	CARBON RESISTOR
	R529	QRD161J-103	CARBON RESISTOR
	R530	QRD161J-103	CARBON RESISTOR
	R531	QRD161J-821	CARBON RESISTOR
	R532	QRD161J-153	CARBON RESISTOR
	R533	QRD161J-103	CARBON RESISTOR
	R534	QRD161J-821	CARBON RESISTOR
	R535	QRD161J-272	CARBON RESISTOR
	R536	QRD161J-104	CARBON RESISTOR
	R537	QRD161J-563	CARBON RESISTOR
	R538	QRD161J-153	CARBON RESISTOR
	R539	QRD161J-333	CARBON RESISTOR
	R540	QRD161J-562	CARBON RESISTOR
	R541	QRD161J-104	CARBON RESISTOR
	R542	QRD161J-223	CARBON RESISTOR
	R544	QRD161J-392	CARBON RESISTOR

△	REF.	PARTS NO.	PARTS NAME
	R545	QRD161J-103	CARBON RESISTOR
	R546	QRD161J-104	CARBON RESISTOR
	R547	QRD161J-473	CARBON RESISTOR
	R548	QRD161J-683	CARBON RESISTOR
	R549	QRD161J-181	CARBON RESISTOR
	R550	QRD161J-103	CARBON RESISTOR
	R559	QRD161J-103	CARBON RESISTOR
	R560	QRD161J-103	CARBON RESISTOR
	R565	QRD161J-683	CARBON RESISTOR
	R566	QRD161J-181	CARBON RESISTOR
	R570	QRD161J-103	CARBON RESISTOR
	R573	QRD161J-183	CARBON RESISTOR
	R640	QRD161J-471	CARBON RESISTOR
	R641	QRD161J-101	CARBON RESISTOR
	R645	QRD161J-151	CARBON RESISTOR
	R647	QRD161J-102	CARBON RESISTOR
	R649	QRD161J-102	CARBON RESISTOR
	R660	QRD161J-272	CARBON RESISTOR
	R661	QRD161J-272	CARBON RESISTOR
	R662	QRD161J-332	CARBON RESISTOR
	R663	QRD161J-332	CARBON RESISTOR
	R664	QRD161J-103	CARBON RESISTOR
	R665	QRD161J-103	CARBON RESISTOR
	R666	QRD161J-103	CARBON RESISTOR
	R667	QRD161J-103	CARBON RESISTOR
	R668	QRD161J-332	CARBON RESISTOR
	R669	QRD161J-332	CARBON RESISTOR
	R672	QRD161J-122	CARBON RESISTOR
	R673	QRD161J-122	CARBON RESISTOR
	R674	QRD161J-104	CARBON RESISTOR
	R675	QRD161J-104	CARBON RESISTOR
	R676	QRV141F-8202AY	CMF RESISTOR
	R677	QRD161J-333	CARBON RESISTOR
	R678	QRV141F-3302AY	CMF RESISTOR
	R681	QRV141F-8202AY	CMF RESISTOR
	R682	QRV141F-3302AY	CMF RESISTOR
	R684	QRV141F-8202AY	CMF RESISTOR
	R685	QRD161J-473	CARBON RESISTOR
	R686	QRV141F-3302AY	CMF RESISTOR
	R687	QRD161J-103	CARBON RESISTOR
	R688	QRD161J-103	CARBON RESISTOR
	R691	QRV141F-8202AY	CMF RESISTOR
	R692	QRD161J-823	CARBON RESISTOR
	R695	QRV141F-8202AY	CMF RESISTOR
	R696	QRD161J-183	CARBON RESISTOR
	R697	QRV141F-3302AY	CMF RESISTOR
	R698	QRD161J-682	CARBON RESISTOR
	R699	PTH61G30BD2R2N	POSISTER
	VR501	QVZ3523-503AZ	V RESISTOR
	X601	VCX5016-934V	CRYSTAL

■ Tuner P.C.Board Parts List
: Drawing No.VMW2326

△	REF.	PARTS NO.	PARTS NAME	△	REF.	PARTS NO.	PARTS NAME
	BP01	VBP4M3B-005	BP FILTER		C062	QCSB1HJ-130Y	C CAPACITOR
	CF01	VCF2L3B-108Z	C FILTER		C063	QCC11EM-473	C CAPACITOR
	CF02	VCF2L3B-108Z	C FILTER		C064	QCS11HJ-270	C. CAPACITOR
	CF03	VCF1Z2Z-108Z	C FILTER		C065	QCBB1HK-151Y	C CAPACITOR
	CF04	CSB456F18	CERA LOCK		C066	QCBB1HK-151Y	C CAPACITOR
	CNO2	EMV5103-002A	PLUG ASSY		C067	QCS11HJ-151	C CAPACITOR
	C001	QCS11HJ-200	C CAPACITOR		C069	QCXB1CM-222Y	C CAPACITOR
	C002	QCBB1HK-102Y	C CAPACITOR		C070	QEK41HM-225	E CAPACITOR
	C003	QCSB1HJ-130Y	C CAPACITOR		C071	QEK41HM-335	E CAPACITOR
	C004	QCT05UJ-100	C. CAPACITOR		D001	KV135ONT	VARI CAP
	C005	QCT05UJ-180	C. CAPACITOR		D002	KV135ONT	VARI CAP
	C006	QCVB1CN-103Y	C CAPACITOR		D003	KV135ONT	VARI CAP
	C007	QCT30CH-200Y	C CAPACITOR		D004	KV135ONT	VARI CAP
	C008	QCVB1CN-103Y	C CAPACITOR		D005	MA165	SI DIODE
	C009	QCT05UJ-100	C. CAPACITOR		D006	MA165	SI DIODE
	C010	QCT30CH-2R2Y	C CAPACITOR		D007	MA165	SI DIODE
	C011	QCVB1CN-103Y	C CAPACITOR		D008	KV155ONT	VARI CAP
	C012	QCBB1HK-151Y	C CAPACITOR		D009	KV155ONT	VARI CAP
	C013	QCC11EM-223	C CAPACITOR		D010	KV155ONT	VARI CAP
	C014	QCBB1HK-151Y	C CAPACITOR		D011	KV155ONT	VARI CAP
	C016	QCVB1CN-103Y	C CAPACITOR		D012	MA165	SI DIODE
	C017	QCBB1HK-102Y	C CAPACITOR		D013	MA165	SI DIODE
	C018	QCVB1CN-103Y	C CAPACITOR		IC01	TA7358P(N)	IC
	C019	QCVB1CN-103Y	C CAPACITOR		IC02	TA8132AN	IC
	C020	QEK61AM-107ZM	E CAPACITOR		IC03	TC9216P	IC
	C021	QCC11EM-473	C CAPACITOR		L001	VQF1B20-017	OSC COIL
	C022	QFP31HG-431ZM	PP CAPACITOR		L002	VQF1B12-004	RF COIL
	C023	QCT30UJ-120Y	C. CAPACITOR		L003	VQZ0030-010	RF COIL(MW)
	C024	QCS11HJ-560	C. CAPACITOR		L004	VQM7U02-404	OSC COIL(MW)
	C025	QEK41HM-104	E CAPACITOR		L005	VQZ0030-008	RF COIL
	C026	QCS11HJ-181	C. CAPACITOR		L006	VQL7U02-502	OSC COIL(LW)
	C027	QCS11HJ-101	C. CAPACITOR		L007	VQP025K-4R7Y	INDUCTOR
	C028	QCS11HJ-180	C CAPACITOR		L008	VQP025K-221Y	INDUCTOR
	C029	QEK40JM-227	E CAPACITOR		L009	VQP025K-4R7Y	INDUCTOR
	C030	QCVB1CN-103Y	C CAPACITOR		L010	VQP025K-4R7Y	INDUCTOR
	C031	QCVB1CN-103Y	C CAPACITOR		L011	VQP025K-4R7Y	INDUCTOR
	C032	QCVB1CN-103Y	C CAPACITOR		Q001	2SC1923(O)E2	TRANSISTOR
	C033	QEK61AM-107ZM	E CAPACITOR		Q002	2SD1302(S,T)	TRANSISTOR
	C034	QCC31EM-333ZV	C CAPACITOR		Q003	2SC2839(E)AC	TRANSISTOR
	C035	QCC11EM-473	C CAPACITOR		Q004	2SA1309(R,S)	TRANSISTOR
	C036	QEK41EM-475	E. CAPACITOR		Q005	2SD1302(S,T)	TRANSISTOR
	C037	QCVB1CN-103Y	C CAPACITOR		Q006	2SC3311(R,S)	TRANSISTOR
	C038	QCBB1HK-102Y	C CAPACITOR		Q007	2SC2839(E)AC	TRANSISTOR
	C039	QCC11EM-473	C CAPACITOR		Q008	DTC114YSTP	TR. I M
	C040	QEK41HM-335	E CAPACITOR		Q009	DTA114YSTP	TRANSISTOR
	C041	QEK41CM-106	E CAPACITOR		Q010	DTA114YSTP	TRANSISTOR
	C042	QCXB1CM-152Y	C CAPACITOR		Q011	DTA114YSTP	TRANSISTOR
	C043	QCVB1CN-103Y	C CAPACITOR		Q012	2SC3311(R,S)	TRANSISTOR
	C044	QEK41HM-104	E CAPACITOR		Q013	2SC3311(R,S)	TRANSISTOR
	C045	QEK41HM-474	E CAPACITOR		Q014	2SA1309(R,S)	TRANSISTOR
	C046	QEK41CM-106	E CAPACITOR		Q015	DTC124ESTP	TRANSISTOR
	C047	QCC31EM-153ZV	C. CAPACITOR		R001	QRD161J-104	CARBON RESISTOR
	C048	QCC31EM-153ZV	C. CAPACITOR		R002	QRD161J-473	CARBON RESISTOR
	C049	QEK41HM-105	E CAPACITOR		R003	QRD161J-4R7	CARBON RESISTOR
	C050	QEK41HM-105	E CAPACITOR		R004	QRD161J-102	CARBON RESISTOR
	C053	QCS11HJ-150	C CAPACITOR		R005	QRD161J-823	CARBON RESISTOR
	C059	QCBB1HK-102Y	C CAPACITOR		R006	QRD161J-101	CARBON RESISTOR
	C060	QCBB1HK-102Y	C CAPACITOR		R008	QRD161J-101	CARBON RESISTOR
	C061	QEK61AM-107ZM	E CAPACITOR		R009	QRD161J-102	CARBON RESISTOR
					R010	QRD161J-101	CARBON RESISTOR

■ Operation Key · Bass/Treble Volume · Volume with
Moter P.C.Board : Drawing No.2312A~C

△	REF.	PARTS NO.	PARTS NAME
	R011	QRD161J-222	CARBON RESISTOR
	R012	QRD161J-103	CARBON RESISTOR
	R013	QRD161J-104	CARBON RESISTOR
	R014	QRD161J-103	CARBON RESISTOR
	R015	QRD161J-222	CARBON RESISTOR
	R016	QRD161J-103	CARBON RESISTOR
	R017	QRD161J-104	CARBON RESISTOR
	R018	QRD161J-102	CARBON RESISTOR
	R019	QRD161J-222	CARBON RESISTOR
	R020	QRD161J-102	CARBON RESISTOR
	R021	QRD161J-103	CARBON RESISTOR
	R022	QRD161J-103	CARBON RESISTOR
	R024	QRD161J-331	CARBON RESISTOE
	R025	QRD161J-394	CARBON RESISTOR
	R026	QRD161J-100	CARBON RESISTOR
	R027	QRD161J-331	CARBON RESISTOE
	R029	QRD161J-103	CARBON RESISTOR
	R030	QRD161J-103	CARBON RESISTOR
	R031	QRD161J-183	CARBON RESISTOR
	R032	QRD161J-223	CARBON RESISTOR
	R033	QRD161J-472	CARBON RESISTOR
	R034	QRD161J-102	CARBON RESISTOR
	R035	QRD161J-102	CARBON RESISTOR
	R036	QRD161J-222	CARBON RESISTOR
	R037	QRD161J-560	CARBON RESISTOR
	R040	QRD161J-102	CARBON RESISTOR
	R041	QRD161J-102	CARBON RESISTOR
	R042	QRD161J-222	CARBON RESISTOR
	R043	QRD161J-103	CARBON RESISTOR
	R044	QRD161J-103	CARBON RESISTOR
	R045	QRD161J-561	CARBON RESISTOR
	R047	QRD161J-562	CARBON RESISTOR
	R048	QRD161J-331	CARBON RESISTOE
	R049	QRD161J-102	CARBON RESISTOR
	R051	QRD161J-561	CARBON RESISTOR
	R052	QRD161J-472	CARBON RESISTOR
	R053	QRD161J-471	CARBON RESISTOR
	R054	QRD161J-222	CARBON RESISTOR
	R055	QRD161J-222	CARBON RESISTOR
	R056	QRD161J-332	CARBON RESISTOR
	R057	QRD161J-102	CARBON RESISTOR
	R058	QRD161J-103	CARBON RESISTOR
	TC02	QAT3722-200ZM	T CAPACITOR
	TC03	QAT3722-300ZM	T CAPACITOR
	T001	VQT7F12-110S	IFT
	T002	VQT7A21-105	IFT
	X001	V472124-A0	CRYSTAL

△	REF.	PARTS NO.	PARTS NAME
	CN313	VMC0063-008	CONNECTOR
	CN314	VMC0063-005	CONNECTOR
	D701	GL-2PR6	LED
	D705	MA165	SI DIODE
	IC701	SBX1610-02	RM RECIVER
	R701	QRD161J-182	CARBON RESISTOR
	R702	QRD161J-122	CARBON RESISTOR
	R704	QRD161J-202	CARBON RESISTOR
	R705	QRD161J-821	CARBON RESISTOR
	R706	QRD161J-122	CARBON RESISTOR
	R707	QRD161J-122	CARBON RESISTOR
	R708	QRD161J-182	CARBON RESISTOR
	R709	QRD161J-222	CARBON RESISTOR
	R710	QRD161J-272	CARBON RESISTOR
	R711	QRD161J-392	CARBON RESISTOR
	R712	QRD161J-562	CARBON RESISTOR
	R713	QRD161J-822	CARBON RESISTOR
	R714	QRD161J-183	CARBON RESISTOR
	S701	QSP4H11-V06Z	TACT SWITCH
	S702	QSP4H11-V06Z	TACT SWITCH
	S703	QSP4H11-V06Z	TACT SWITCH
	S705	QSP4H11-V06Z	TACT SWITCH
	S706	QSP4H11-V06Z	TACT SWITCH
	S707	QSP4H11-V06Z	TACT SWITCH
	S708	QSP4H11-V06Z	TACT SWITCH
	S709	QSP4H11-V06Z	TACT SWITCH
	S710	QSP4H11-V06Z	TACT SWITCH
	S711	QSP4H11-V06Z	TACT SWITCH
	S712	QSP4H11-V06Z	TACT SWITCH
	S713	QSP4H11-V06Z	TACT SWITCH
	S714	QSP4H11-V06Z	TACT SWITCH
	VR302	VCV1001-110	VR
	VR303	VCV1001-110	VR

■ Pre-amplifier Mecha Control P.C.Board
: Drawing No.VMW1254A-B

△	REF.	PARTS NO.	PARTS NAME
	CN301	VMC0064-009	CONNECTOR
	CN302	VMC0064-005	CONNECTOR
	CN303	VMC0156-S12	CONNECTOR
	CN304	VMC0156-S03	CONNECTOR
	CN305	QMV5012-003	CONNECTOR
	CN501	VMC0107-R06	4P PLUG ASSY
	CN504	VMC0156-S10	CONNECTOR
	CN505	VMC0156-S12	CONNECTOR
	C101	QEK41HM-225	E.CAPA.
	C102	QCBB1HK-102Y	C CAPACITOR
	C103	QFV41HJ-103	TF CAPACITOR
	C104	QEK60JM-107ZM	E CAPACITOR
	C105	QER41HM-105	E CAPACITOR
	C106	QEK41HM-474	E CAPACITOR
	C107	QEK41HM-474	E CAPACITOR
	C108	QCBB1HK-471Y	C CAPACITOR
	C110	QCBB1HK-102Y	C CAPACITOR
	C111	QFV41HJ-224	TF CAPACITOR
	C112	QEK41HM-225	E.CAPA.
	C113	QEK41EM-475	E.CAPACITOR
	C114	QEK41HM-474	E CAPACITOR
	C115	QCC11EM-473	C CAPACITOR
	C116	QER41HM-105	E CAPACITOR
	C117	QEK41EM-475	E.CAPACITOR
	C118	QFV41HJ-104	TF CAPACITOR
	C119	QCBB1HK-102Y	C CAPACITOR
	C120	QFV11HJ-153ZN	TF CAPACITOR
	C121	QFV41HJ-333	TF CAPACITOR
	C122	QFV11HJ-153ZN	TF CAPACITOR
	C123	QEK41HM-105	E CAPACITOR
	C124	QCBB1HK-102Y	C CAPACITOR
	C125	QCS32HJ-331ZV	C CAPACITOR
	C126	QCBB1HK-331Y	C CAPACITOR
	C127	QCXB1CM-222Y	C CAPACITOR
	C201	QEK41HM-225	E.CAPA.
	C202	QCBB1HK-102Y	C CAPACITOR
	C203	QFV41HJ-103	TF CAPACITOR
	C204	QEK60JM-107ZM	E CAPACITOR
	C205	QER41HM-105	E CAPACITOR
	C206	QEK41HM-474	E CAPACITOR
	C207	QEK41HM-474	E CAPACITOR
	C208	QCBB1HK-471Y	C CAPACITOR
	C210	QCBB1HK-102Y	C CAPACITOR
	C211	QFV41HJ-224	TF CAPACITOR
	C212	QEK41HM-225	E.CAPA.
	C213	QEK41EM-475	E.CAPACITOR
	C214	QEK41HM-474	E CAPACITOR
	C215	QCC11EM-473	C CAPACITOR
	C216	QER41HM-105	E CAPACITOR
	C217	QEK41EM-475	E.CAPACITOR
	C218	QFV41HJ-104	TF CAPACITOR
	C219	QCBB1HK-102Y	C CAPACITOR
	C220	QFV11HJ-153ZN	TF CAPACITOR
	C221	QFV41HJ-333	TF CAPACITOR
	C222	QFV11HJ-153ZN	TF CAPACITOR
	C223	QEK41HM-105	E CAPACITOR
	C224	QCBB1HK-102Y	C CAPACITOR
	C225	QCS32HJ-331ZV	C CAPACITOR
	C226	QCBB1HK-331Y	C CAPACITOR
	C227	QCXB1CM-222Y	C CAPACITOR

△	REF.	PARTS NO.	PARTS NAME
	C301	QER41AM-107	E CAPACITOR
	C302	QFV41HJ-103	TF CAPACITOR
	C303	QFV11HJ-153ZN	TF CAPACITOR
	C304	QCS11HJ-330	C CAPACITOR
	C305	QCXB1CM-182Y	C.CAPACITOR
	C306	QCBB1HK-681Y	C CAPACITOR
	C307	QEK61AM-107Z	E CAPACITOR
	C308	QER41HM-225	E.CAPACITOR
	C309	QER41CM-106	E CAPACITOR
	C310	QEK41CM-106	E CAPACITOR
	C311	QEK61AM-107Z	E CAPACITOR
	C312	QEK41CM-106	E CAPACITOR
	C313	QEK61AM-107Z	E CAPACITOR
	C314	QEK41CM-476	E CAPACITOR
	C315	QEK41CM-476	E CAPACITOR
	C316	QFLA1HJ-682ZM	M CAPACITOR
	C317	QFLA1HJ-682ZM	M CAPACITOR
	C318	QFLA1HJ-562ZM	M CAPACITOR
	C319	QFLA1HJ-562ZM	M CAPACITOR
	C320	QFG32AJ-223ZN	
	C321	QCVB1CM-103Y	C CAPACITOR
	C322	QEK41CM-476	E CAPACITOR
	C323	QEK61AM-336ZN	E CAPACITOR
	C324	QFV41HJ-224	TF CAPACITOR
	C501	QCVB1CM-103Y	C CAPACITOR
	C502	QEK41CM-476	E CAPACITOR
	C503	QCVB1CM-103Y	C CAPACITOR
	C504	QEK60JM-107ZM	E CAPACITOR
	C505	QCXB1CM-272Y	C.CAPACITOR
	C506	QCVB1CM-103Y	C CAPACITOR
	C507	QER41HM-225	E.CAPACITOR
	C508	QEK41CM-106	E CAPACITOR
	C509	QCVB1CM-103Y	C CAPACITOR
	C510	QEK41HM-105	E CAPACITOR
	C514	QCS11HJ-470	C CAPACITOR
	C515	QCVB1CM-103Y	C CAPACITOR
	C801	QFV41HJ-683	TF CAPACITOR
	C802	QCBB1HK-102Y	C CAPACITOR
	C803	QCVB1CM-103Y	C CAPACITOR
	C804	QCVB1CM-103Y	C CAPACITOR
	C805	QCVB1CM-103Y	C CAPACITOR
	C806	QEK61AM-107Z	E CAPACITOR
	C807	QEK60JM-107ZM	E CAPACITOR
	D101	MA165	SI DIODE
	D102	MA165	SI DIODE
	D201	MA165	SI DIODE
	D202	MA165	SI DIODE
	D301	MA165	SI DIODE
	D801	HSS104TJ	SI DIODE
	D802	MA4091(M)	ZENER DIODE
	D803	MA4051(M)	Z DIODE
	D804	HSS104TJ	SI DIODE
	D805	HSS104TJ	SI DIODE
	IC301	UPC1228HA	IC
	IC302	LA3220	IC
	IC303	UPC1330HA	IC
	IC304	HA12134A	IC
	IC501	TA8409S	IC
	IC502	TA8409S	IC
	IC503	LZ93D58	IC

△	REF.	PARTS NO.	PARTS NAME
	L101	VQP0001-183S	INDUCTOR
	L102	VQP0001-562S	INDUCTOR
	L201	VQP0001-183S	INDUCTOR
	L202	VQP0001-562S	INDUCTOR
	L301	VQH1008-017	OSC COIL(BIAS)
	L302	VQP0028-100Z	INDUCTOR
	L501	VQP0028-100Z	INDUCTOR
	Q101	UN4210	TRANSISTOR
	Q102	2SC2001(L,K)	TRANSISTOR
	Q103	2SC2001(L,K)	TRANSISTOR
	Q104	UN4210	TRANSISTOR
	Q105	UN4210	TRANSISTOR
	Q201	UN4210	TRANSISTOR
	Q203	2SC2001(L,K)	TRANSISTOR
	Q204	UN4210	TRANSISTOR
	Q205	UN4210	TRANSISTOR
	Q301	2SC2785(E,F)	TRANSISTOR
	Q302	2SC2785(E,F)	TRANSISTOR
	Q303	UN4210	TRANSISTOR
	Q305	2SD1302(S,T)	TRANSISTOR
	Q306	2SD1302(S,T)	TRANSISTOR
	Q501	2SA952(L,K)	TRANSISTOR
	Q502	UN4213	TRANSISTOR
	Q503	2SD1302(S,T)	TRANSISTOR
	Q504	2SD1302(S,T)	TRANSISTOR
	Q505	2SD1302(S,T)	TRANSISTOR
	Q506	UN411F	TRANSISTOR
	Q507	UN4213	TRANSISTOR
	Q801	2SA1359(OY)	TRANSISTOR
	Q802	2SC2785(E,F)	TRANSISTOR
	Q803	UN4211	TRANSISTOR
	Q804	2SC2785(E,F)	TRANSISTOR
	Q805	2SA952(L,K)	TRANSISTOR
	Q806	2SC2785(E,F)	TRANSISTOR
	Q807	UN4213	TRANSISTOR
	R101	QRD161J-680	CARBON RESISTOR
	R102	QRD161J-334	CARBON RESISTOR
	R103	QRD161J-682	CARBON RESISTOR
	R104	QRD161J-562	CARBON RESISTOR
	R105	QRD161J-122	CARBON RESISTOR
	R106	QRD161J-103	CARBON RESISTOR
	R107	QRD161J-103	CARBON RESISTOR
	R108	QRD161J-224	CARBON RESISTOR
	R110	QRD161J-472	CARBON RESISTOR
	R111	QRD161J-153	CARBON RESISTOR
	R112	QRD161J-153	CARBON RESISTOR
	R113	QRD161J-182	CARBON RESISTOR
	R114	QRD161J-103	CARBON RESISTOR
	R115	QRD161J-221	CARBON RESISTOR
	R116	QRD161J-182	CARBON RESISTOR
	R117	QRD161J-392	CARBON RESISTOR
	R118	QRD161J-392	CARBON RESISTOR
	R119	QRD161J-682	CARBON RESISTOR
	R121	QRD161J-472	CARBON RESISTOR
	R122	QRD161J-102	CARBON RESISTOR
	R124	QRD161J-221	CARBON RESISTOR
	R201	QRD161J-680	CARBON RESISTOR
	R202	QRD161J-334	CARBON RESISTOR
	R203	QRD161J-682	CARBON RESISTOR
	R204	QRD161J-562	CARBON RESISTOR

△	REF.	PARTS NO.	PARTS NAME
	R205	QRD161J-122	CARBON RESISTOR
	R206	QRD161J-103	CARBON RESISTOR
	R207	QRD161J-103	CARBON RESISTOR
	R208	QRD161J-224	CARBON RESISTOR
	R210	QRD161J-472	CARBON RESISTOR
	R211	QRD161J-153	CARBON RESISTOR
	R212	QRD161J-153	CARBON RESISTOR
	R213	QRD161J-182	CARBON RESISTOR
	R214	QRD161J-103	CARBON RESISTOR
	R215	QRD161J-221	CARBON RESISTOR
	R216	QRD161J-182	CARBON RESISTOR
	R217	QRD161J-392	CARBON RESISTOR
	R218	QRD161J-392	CARBON RESISTOR
	R219	QRD161J-682	CARBON RESISTOR
	R221	QRD161J-472	CARBON RESISTOR
	R222	QRD161J-102	CARBON RESISTOR
	R224	QRD161J-221	CARBON RESISTOR
	R301	QRD161J-221	CARBON RESISTOR
	R302	QRD161J-331	CARBON RESISTOR
	R303	QRD161J-473	CARBON RESISTOR
	R304	QRD161J-225	CARBON RESISTOR
	R305	QRD161J-121	CARBON RESISTOR
	R306	QRD161J-221	CARBON RESISTOR
	R307	QRD161J-103	CARBON RESISTOR
	R308	QRD161J-103	CARBON RESISTOR
	R309	QRD161J-183	CARBON RESISTOR
	R311	QRD161J-475	CARBON RESISTOR
	R312	QRD161J-475	CARBON RESISTOR
	R313	QRZ0077-150X	F.RES.I.M
	R314	QRD161J-273	CARBON RESISTOR
	R315	QRD161J-273	CARBON RESISTOR
	R316	QRD161J-3R3	CARBON RESISTOR
	R317	QRD161J-221	CARBON RESISTOR
	R318	QRD161J-103	CARBON RESISTOR
	R319	QRD161J-101	CARBON RESISTOR
	R320	QRD161J-222	CARBON RESISTOR
	R321	QRD161J-104	CARBON RESISTOR
	R501	QRD161J-102	CARBON RESISTOR
	R502	QRD161J-123	CARBON RESISTOR
	R503	QRD161J-682	CARBON RESISTOR
	R504	QRD161J-684	CARBON RESISTOR
	R505	QRD161J-472	CARBON RESISTOR
	R507	QRD143J-151S	CARBON RESISTOR
	R508	QRD161J-472	CARBON RESISTOR
	R509	QRD161J-221	CARBON RESISTOR
	R510	QRD161J-472	CARBON RESISTOR
	R511	QRD161J-472	CARBON RESISTOR
	R512	QRD161J-103	CARBON RESISTOR
	R513	QRD161J-221	CARBON RESISTOR
	R514	QRD161J-103	CARBON RESISTOR
	R515	QRD161J-223	CARBON RESISTOR
	R516	QRD161J-183	CARBON RESISTOR
	R517	QRD161J-563	CARBON RESISTOR
	R518	QRD161J-224	CARBON RESISTOR
	R519	QRD161J-103	CARBON RESISTOR
	R520	QRD161J-103	CARBON RESISTOR
	R521	QRD161J-472	CARBON RESISTOR
	R522	QRD161J-392	CARBON RESISTOR
	R523	QRD161J-471	CARBON RESISTOR
	R524	QRD161J-471	CARBON RESISTOR

■ Deck Function-Operation Key P.C.Board
: Drawing No.VMW2317

△	REF.	PARTS NO.	PARTS NAME
	R525	QRD161J-471	CARBON RESISTOR
	R526	QRD161J-471	CARBON RESISTOR
	R801	QRD161J-391	CARBON RESISTOR
	R802	QRD161J-472	CARBON RESISTOR
	R803	QRD161J-224	CARBON RESISTOR
	R804	QRD161J-102	CARBON RESISTOR
	R805	QRD161J-102	CARBON RESISTOR
	R806	QRD161J-562	CARBON RESISTOR
	R807	QRD161J-222	CARBON RESISTOR
	R808	QRD161J-102	CARBON RESISTOR
	R809	QRZ0077-4R7X	F. RESISTOR
	R810	QRD161J-121	CARBON RESISTOR
	R811	QRD161J-102	CARBON RESISTOR
	R812	QRD161J-331	CARBON RESISTOR
	R813	QRD161J-564	CARBON RESISTOR
	VR101	QVPA603-502AZM	SEMI.V.RESISTOR
	VR102	QVPA603-502AZM	SEMI.V.RESISTOR
	VR103	QVPA603-104M	SEMI.V.RESISTOR
	VR201	QVPA603-502AZM	SEMI.V.RESISTOR
	VR202	QVPA603-502AZM	SEMI.V.RESISTOR
	VR203	QVPA603-104M	SEMI.V.RESISTOR
	VR501	QVPA603-103AZM	SEMI.V.RESISTOR

△	REF.	PARTS NO.	PARTS NAME
	CN601	VMC0156-P03	CONNECTOR
	CN602	VMC0156-P12	CONNECTOR
	CN603	VMC0156-P12	CONNECTOR
	CN604	VMC0156-P10	CONNECTOR
	CN605	TYCLL-008	CONNECTOR
	CN606	TYCHL-008	CONNECTOR
	CN607	VMC0064-002	CONNECTOR
	CN609	VMC0155-R09	CONNECTOR
	C601	VCE0061-108	E CAPACITOR
	C602	QCF11HP-223	C CAPACITOR
	C603	QCF11HP-223	C CAPACITOR
	C604	QCF11HP-223	C CAPACITOR
	C605	QCF11HP-223	C CAPACITOR
	C606	QFV41HJ-683	TF CAPACITOR
	C607	QFN41HJ-222	M CAPACITOR
	D601	11E1	SI DIODE
	D602	11E1	SI DIODE
	D603	11E1	SI DIODE
	D604	11E1	SI DIODE
	J353	VMJ4024-001	JACK
	Q601	UN411F	TRANSISTOR
	Q602	UN4213	TRANSISTOR
	Q603	2SC945(P,Q)	TRANSISTOR
	Q604	2SC945(P,Q)	TRANSISTOR
	Q605	2SA992(E,F)	TRANSISTOR
	R158	QRD161J-121	CARBON RESISTOR
	R258	QRD161J-121	CARBON RESISTOR
	R605	QRD161J-122	CARBON RESISTOR
	R606	QRD161J-122	CARBON RESISTOR
	R607	QRD161J-182	CARBON RESISTOR
	R608	QRD161J-222	CARBON RESISTOR
	R609	QRD161J-272	CARBON RESISTOR
	R610	QRD161J-392	CARBON RESISTOR
	R611	QRD161J-562	CARBON RESISTOR
	R612	QRD161J-822	CARBON RESISTOR
	R613	QRD161J-183	CARBON RESISTOR
	R614	QRD161J-331	CARBON RESISTOR
	R615	QRD161J-331	CARBON RESISTOR
	R616	QRD161J-331	CARBON RESISTOR
	R621	QRD161J-821	CARBON RESISTOR
	R622	QRD161J-102	CARBON RESISTOR
	R623	QRD161J-102	CARBON RESISTOR
	R624	QRD161J-102	CARBON RESISTOR
	R625	QRD161J-102	CARBON RESISTOR
	R626	QRD161J-102	CARBON RESISTOR
	R627	QRD161J-221	CARBON RESISTOR
	R628	QRD161J-473	CARBON RESISTOR
	R629	QRD161J-682	CARBON RESISTOR
	R630	QRD161J-102	CARBON RESISTOR
	R631	QRD161J-561	CARBON RESISTOR
	S601	QSP4H11-V05Z	TACT SWITCH
	S602	QSP4H11-V05Z	TACT SWITCH
	S603	QSP4H11-V05Z	TACT SWITCH
	S604	QSP4H11-V05Z	TACT SWITCH
	S605	QSP4H11-V05Z	TACT SWITCH
	S606	QSP4H11-V05Z	TACT SWITCH
	S607	QSP4H11-V05Z	TACT SWITCH
	S608	QSP4H11-V05Z	TACT SWITCH
	S609	QSP4H11-V05Z	TACT SWITCH
	S610	QSP4H11-V05Z	TACT SWITCH

■ Reel Moter P.C.Board : Drawing No.VMW3272

REF	PARTS NO.	PARTS NAME
CN1	VMC0107-R08	SOCKET
C1	QETB1CM-336N	E. CAPACTOR
R1	QRD161J-102	C. RESISTOR

■ Cam Switch P.C.Board : Drawing No.VMW3273

REF	PARTS NO.	PARTS NAME
CN2	VMC0107-R07	SOCKET
	VKS3495-00A	CAM SWITCH UNIT
	DN6851A	HOLL IC
	VKS3487-001	IC HOLDER
	VKZ4611-001	EARTH PIN

■ Power Supply Power Amplifier P.C.Board
: Drawing No. VMW1249A·B

REF.	PARTS NO.	PARTS NAME
Q252	2SD1302(S,T)	TRANSISTOR
CN351	VMC0156-S12	CONNECTOR
CN352	VMC0156-P12	CONNECTOR
CN355	VMC0155-005	CONNECTOR
CN951	VMC0156-P08	CONNECTOR
CN952	VMC0156-S08	CONNECTOR
CN953	VMC0156-S08	CONNECTOR
CN954	VMC0156-P08	CONNECTOR
C151	QETC1EM-476ZM	E.CAPACITOR
C152	QCB1HK-471Y	C CAPACITOR
C153	QCC11EM-104	C CAPACITOR
C154	QET41CR-228	E CAPACITOR
C155	QFV41HJ-224	TF CAPACITOR
C251	QETC1EM-476ZM	E.CAPACITOR
C252	QCB1HK-471Y	C CAPACITOR
C253	QCC11EM-104	C CAPACITOR
C254	QET41CR-228	E CAPACITOR
C255	QFV41HJ-224	TF CAPACITOR
C351	QFV71HJ-393ZM	FILM CAPACITOR
C352	QFV71HJ-393ZM	FILM CAPACITOR
C353	QETC1EM-107ZM	E.CAPACITOR
C354	QETC1EM-106ZM	E.CAPACITOR
C355	QETB1VM-338N	E.CAPACITOR
C356	QCC11EM-683	C CAPACITOR
C357	QETB1VM-227N	E CAPACITOR
C901	QETB1VM-227N	E CAPACITOR
C902	QFV41HJ-683	TF CAPACITOR
C951	QFV41HJ-683	TF CAPACITOR
C952	QFV41HJ-683	TF CAPACITOR
C953	QFV41HJ-683	TF CAPACITOR
C954	QFV41HJ-683	TF CAPACITOR
D351	MA700	ZENER DIODE
D352	MA700	ZENER DIODE
D353	HSS104TJ	SI DIODE
D354	HSS104TJ	SI DIODE

REF.	PARTS NO.	PARTS NAME
D902	11E1	SI DIODE
D951	S4VB10-4002	SI DIODE
IC351	TA8216H(JVC)	IC
J351	EMB90YV-401A	SPK.TERMINAL
J352	EMV7127-017	CONNECTOR
Q151	2SD1302(S,T)	TRANSISTOR
Q152	2SD1302(S,T)	TRANSISTOR
Q252	2SD1302(S,T)	TRANSISTOR
Q351	UN4213TA	TRANSISTOR
Q901	2SC2785(E,F)	TRANSISTOR
Q902	2SA952(L,K)	TRANSISTOR
RY951	VSK1D24-111	RELAY
R150	QRD161J-471	CARBON RESISTOR
R151	QRD161J-102	CARBON RESISTOR
R152	QRD161J-472	CARBON RESISTOR
R153	QRD161J-561	CARBON RESISTOR
R154	QRD161J-272	CARBON RESISTOR
R155	QRD161J-475	CARBON RESISTOR
R156	QRD161J-475	CARBON RESISTOR
R157	QRD161J-2R2	CARBON RESISTOR
R250	QRD161J-471	CARBON RESISTOR
R251	QRD161J-102	CARBON RESISTOR
R252	QRD161J-472	CARBON RESISTOR
R253	QRD161J-561	CARBON RESISTOR
R254	QRD161J-272	CARBON RESISTOR
R255	QRD161J-475	CARBON RESISTOR
R256	QRD161J-475	CARBON RESISTOR
R257	QRD161J-2R2	CARBON RESISTOR
R352	QRD161J-472	CARBON RESISTOR
R353	QRD161J-475	CARBON RESISTOR
R901	QRD161J-473	CARBON RESISTOR
R902	QRD121J-102	CARBON RESISTOR
R903	QRD161J-104	CARBON RESISTOR
R904	QRD161J-103	CARBON RESISTOR
R905	QRD161J-223	CARBON RESISTOR
R906	QRD161J-223	CARBON RESISTOR