

**JUNE 1948**

**35 CENTS**

**EVERYTHING IN TELEVISION • RADIO • ELECTRONICS  
FOR THE RADIO SERVICE • TECHNICIAN**

**RADIO**

**MAINTENANCE**

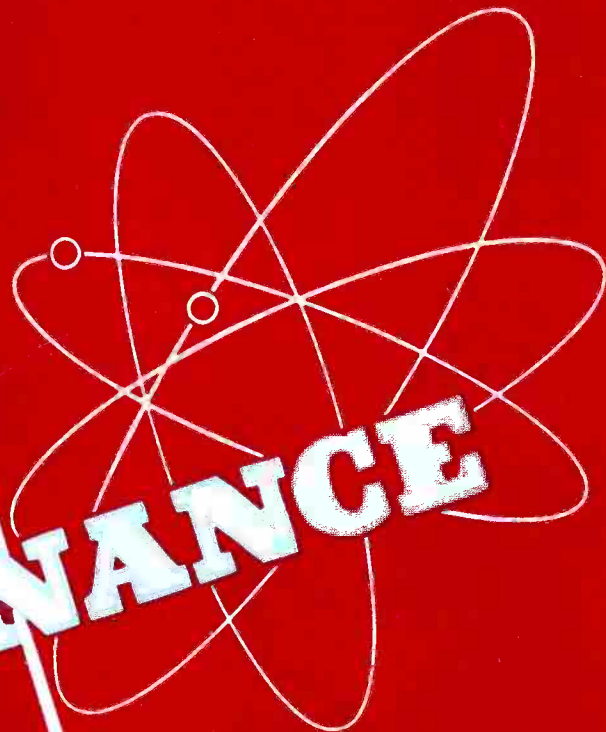

**INTERFERENCE—PART II  
HEATER-CATHODE HUM  
SUPER SERVICE  
F.M. AND YOU**

YEARLY SUBSCRIPTION \$3.00

**BOLAND & BOYCE INC., PUBLISHERS MONTCLAIR, N. J.**



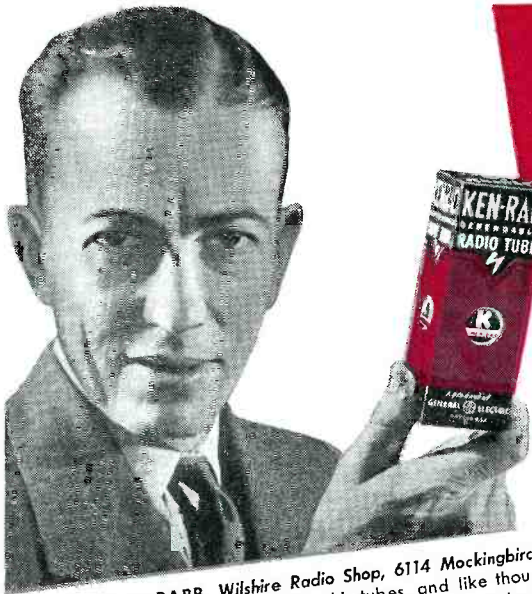

TILLMAN F. BABB, Wilshire Radio Shop, 6114 Mockingbird Lane, Dallas, Texas. Tillman knows his tubes, and like thousands of outstanding servicemen, he prefers Ken-Rad tubes. They're quality, through and through.



# "KEN-RAD TUBES PAY OFF!"

"Ken-Rad tubes? I'll say I use them!

"Ken-Rad tubes have been doing a job for me for 13 years. And I'll say this—there's not a better tube made. They perform well and stand up.

"You can depend on them to make customers happy. Happy customers build business.

"And I'm not letting customers down. I'm selling *quality*. It pays off!

"That's why I'm for Ken-Rad tubes!"

## "Ken-Rad tubes are MADE TO PAY OFF"

"We make Ken-Rad tubes to stand up—satisfy users—and build business for servicemen.

"Before a Ken-Rad tube is sent to you it must pass a series of tests for noise, microphonics, static, life, short, appearance, gas, air and hum.

"That's why Ken-Rad tubes meet your most exacting demands—for quality, stamina, endurance.

"That's why they'll bring customers back satisfied."



ROBERT HAGAN, Shop Foreman, Quality Laboratory, is in charge of the strict Life Test, above. It's typical of the numerous tests that Ken-Rad tubes must pass before leaving the plant.

**The Serviceman's Tube**

178-GA7-8850

# KEN-RAD Radio Tubes

PRODUCT OF GENERAL ELECTRIC COMPANY

Schenectady 5, New York



*"Certainly*  
**WE HAVE ALL 17 VOLUMES**  
*... and we have the Rider Television Manual on Order"*

"Certainly we have all 17 Rider Manuals—and the Television Manual on order. I can't imagine any high class, efficient radio service laboratory operating satisfactorily without them. I'll have Volume 18 on the shelf, too, as soon as it's published,"

*Says* **R. B. GRAF**, Service Mgr.  
 Ward Radio & Appliances, Silver Spring, Md.



**OUT IN JUNE!**  
**Another Rider "First"**  
 Rider again leads the way. This time with the first industry wide television manual.  
**VOL. I . . . . . RIDER TELEVISION MANUAL**

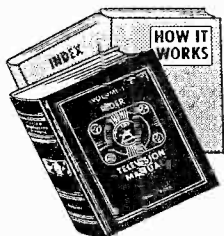

Circuit Descriptions—Schematics—Patterns—Alignment—Voltage and Resistance Tables—Chassis Views—Parts Lists—Double-Spread and Giant Pages—Standard Rider Looseleaf Binder—Approximately 1350 Pages.

- **"HOW IT WORKS" BOOK (about 200 pages)** (available separately at \$2.70)

Explanation of the underlying theories of Antennas—Channel Frequencies—R-F Sections—Sound and Video Channels—Sync and Sweep Circuits—Waveforms in Circuits—Power Supplies—Alignment and Servicing.

- **Complete, Accurate, Separate INDEX** Approximately 1350 Pages, PLUS two supplementary books— \$15.00.

**ORDER YOURS FROM YOUR JOBBER**

A conspicuous characteristic of Rider Manual owners is their unswerving loyalty to "The World's Greatest Compilation of Radio Servicing Data." This steady patronage is born of the benefits provided by Rider Manuals during eighteen years of continuing service to the servicing industry.

Because of their value, complete sets of Rider Manuals will be found over the benches of practically every money-making radio servicing shop.

There is a reason for their constant use. They provide the greatest coverage: More brand names. More single band receivers. More multiband receivers. More record changers. More wire recorders. More wireless record players. More essential servicing data on all radio and associated products.

*Plus:* Rider-exclusive, "clarified-schematics" (beginning with Vol. XV) breaking down all multiband receivers.

*Plus:* the separate "How It Works" book clarifying the theories underlying the electrical and mechanical innovations in the newest sets.

*And Now!!* Volume I of the Rider TELEVISION Manual, brings you up-to-the-minute on the biggest servicing development since the very introduction of radio. Keep your data abreast of the latest sources of profit. Give your shop the sign of successful servicing, a complete set of all the Rider Manuals.

*Check! You too need all 17*

Volume XVII . . . . .	\$15.00	Abridged Manuals I to V (one vol.) . . . . .	\$17.50
Volume XVI . . . . .	8.40	Record Changers and Recorders . . . . .	9.00
Volume XV . . . . .	18.00	Master Index, covering Manuals, Vols. I to XV . . . . .	1.50
Volume XIV to VII (ea. Vol.) . . . . .	15.00		
Volume VI . . . . .	11.00		

JOHN F. RIDER PUBLISHER, Inc., 404 Fourth Avenue, New York 16  
 Export Agent: Rock International Corp., 13 E. 40th St., N.Y.C. Cable ARLAB

**RIDER MANUALS** *Mean* **SUCCESSFUL SERVICING**

NOTE: The Mallory Radio Service Encyclopedia, 6th Edition, makes reference to only one source of Radio Receiver Schematics—Rider Manuals.



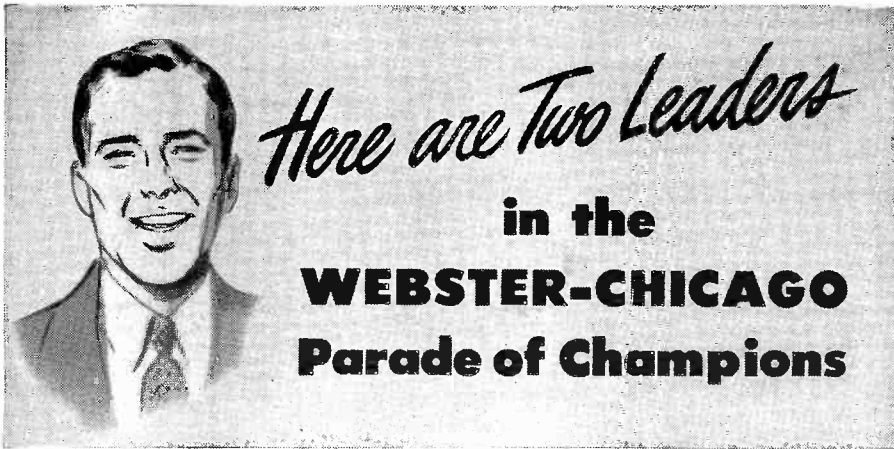

You can *sell* the advanced engineering, precision manufacturing and customer satisfaction of Webster-Chicago Record Changers. The wide preference for these "champions" has resulted in their use in nationally famous radio-phonograph combinations.

And, for profitable replacements — leading Service Dealers standardize on Webster-Chicago for trouble-free installations.

Here are two leaders in the parade of champions that can be profit-builders for you *right now!*

**MODEL 156 with Automatic Stop.** Model 156 embodies the most advanced features of record changer design — a vastly improved pick-up arm that accommodates a cartridge of low needle pressure—automatic stop—simpler, faster, more positive changer action. Model 156-27 supplied with G. E. variable reluctance pickup.

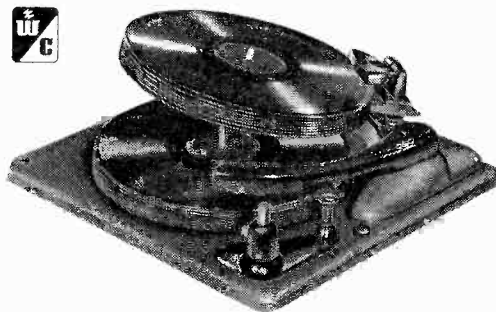

*If you don't have a copy of "Operating and Service Instructions for Model 156 Record Changer" write for a copy today.*

**MODEL 50 for Small Radio-Phonograph Combinations** Compactly designed for use with smaller radio-phonograph combinations. Precision-built for trouble-free operation. Base dimensions: 12 x 12 1/8 in. Vertical space requirements: 6 1/2 in. above, 2 1/2 in. below top of mounting board.



*Be sure you have a copy of "Operating and Service Instructions for Model 50 Record Changer"—write for one today, if you don't have one on file.*

For complete information on these and other Webster-Chicago Record Changers get in touch with your distributor or write us for the name of the Webster-Chicago distributor nearest to you.

Makers of Webster-Chicago Wire Recorders and Nylon Phonograph Needles

**WEBSTER-CHICAGO**

5610 BLOOMINGDALE AVENUE • CHICAGO 39, ILLINOIS

## OFF OUR CHEST

From time to time we receive letters from readers who feel that F.M. and Television will not be available in their locality for many years to come. While it is true that both of these services have limitations in regard to distance, these limitations are not as severe as was previously believed. For years it has been thought that F.M. would only be practical in the large population centers where many listeners would be grouped close to the transmitting station. As F.M. stations were placed in operation across the country and receiving equipment was improved, it was discovered that reception was possible at comparatively long distances from a station. In some rural areas it has been possible to secure better, more reliable F.M. reception than was ever obtainable with A.M.

The point we are trying to make is that both F.M. and Television are going to be available in almost every part of the country in the near future. Don't make the mistake of deciding that you will not need to prepare yourself for these new fields, because you are located a considerable distance from a city.

Television is destined to play an important part in the country's economic future. The manufacturer and the broadcaster realizing this are performing the research and development necessary to make nationwide television possible.

Difficulties far more imposing than those which television now faces if it is to be available throughout the country, have already been overcome in bringing it to the stage at which it now stands.

The advent of F.M. and Television has created a great opportunity for all service technicians. Without a large group of highly trained service technicians, it will not be possible to keep millions of F.M. and Television receivers operating. The need for trained service technicians has already become a problem in the large Eastern metropolitan centers where television is already an actuality. Prepare yourself now, and don't be caught with your training down when F.M. and Television arrive in your town.

# RADIO

# MAINTENANCE

INCLUDING  
ELECTRONIC  
MAINTENANCE

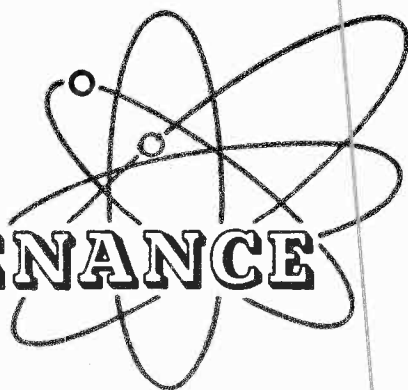

Volume 4

JUNE 1948

Number 6

## CONTENTS

Super Service .....	P. Martin	16
Radio Service can be big business		
Interference—Part II .....	Paul M. Miller	18
Installation of noise filters		
Heater-Cathode Hum .....	Albert Loisch	21
Cause and means of elimination		
F.M. and You .....	J. R. Johnson	22
F.M. is an important part of Radio Service		
Trouble Shooting Receiver Distortion .....	K. E. Stewart	24
Part II of a three-part series		
Pueblo Servicemen's Association .....	R. C. Travers	27
An organization helps the service technician		
Review of Trade Literature .....		32
Catalogs, books, etc.		
Electronically Speaking .....		37
Over the Bench .....	John T. Frye	40
A serviceman's opinion		
The Industry Presents .....		42
New products		
Time Savers .....	H. Leeper	44
The Notebook .....		47
Practical suggestions from readers		

**WILLIAM F. BOYCE**  
Publisher

**JOSEPH J. ROCHE**  
Editor

**VICTOR M. TURNER**  
Art Director

**FRANK SCHMITT**  
Eastern Advertising

**MARVIN H. ALBERT**  
Associate Editor

**THOMAS A. BYRNES**  
Director of Field Services  
and Quality Control

**STUART J. OSTEN**  
Midwestern Advertising  
Midwestern Office  
228 No. La Salle St.  
Chicago 1, Ill.  
Dearborn 3507

**MORTON SCHERAGA**  
Contributing Editor  
Eastern Office  
460 Bloomfield Avenue  
Montclair, N. J.  
Montclair 2-7101

**AL JOHNSTON**  
Circulation Manager  
West Coast  
Swain Associates  
639 So. Wilton Place  
Los Angeles 5, Calif.  
Dunkirk 8-2248

Copyright 1948, Boland & Boyce, Inc.

Radio Maintenance is published monthly by Boland & Boyce, Inc., at 34 No. Crystal St., East Stroudsburg, Pa., U.S.A.; Executive and Editorial Office, 460 Bloomfield Ave., Montclair, N. J. Subscription Rates: In U. S., Mexico, South and Central America, and U. S. possessions, \$3.00 for 1 year, \$5.00 for two years, single copies 35 cents; in Canada, \$3.50 for 1 year, \$6.00 for 2 years, single copies 40 cents; in British Empire, \$4.00 for 1 year, \$7.00 for 2 years, single copies 50 cents; all other foreign countries, \$5.00 for 1 year.

Entered as Second Class matter July 13, 1946, at Post Office, East Stroudsburg, Pa., under the Act of March 3, 1879.

Change of address: Four weeks' notice required for change of address. When ordering a change, please furnish an address stencil impression from a recent issue if you can. Address changes cannot be made without the old stencil as well as the new one.

# American Beauty

## ELECTRIC SOLDERING IRONS

are sturdily built for the hard usage of industrial service. Have plug type tips and are constructed on the unit system with each vital part, such as heating element, easily removable and replaceable. In 5 sizes, from 50 watts to 550 watts.

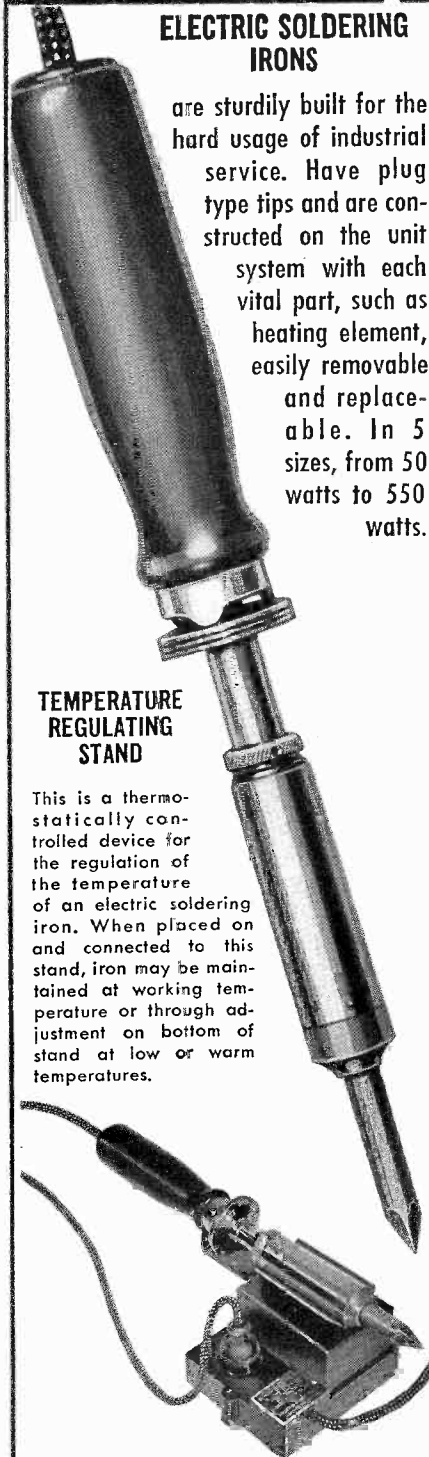

## TEMPERATURE REGULATING STAND

This is a thermostatically controlled device for the regulation of the temperature of an electric soldering iron. When placed on and connected to this stand, iron may be maintained at working temperature or through adjustment on bottom of stand at low or warm temperatures.

For descriptive literature write

110-1

**AMERICAN ELECTRICAL  
HEATER COMPANY**  
DETROIT 2, MICH., U. S. A.



**SYLVANIA  
RADIO TUBES...**



**... MAKE THE SERVICE  
DEALER HAPPY...**



**... BECAUSE THEY KEEP  
SET-OWNERS HAPPY!**

**W**hether a replacement job calls for miniatures, standard tubes or the famous Lock-Ins, you can install Sylvania Tubes with complete confidence. You *know* they'll give the kind of performance that builds good will among your customers!

And... don't fail to cash in on Sylvania's national advertising. Make full use of the Radio Serviceman's decal—*your* decal—featured in every single one of Sylvania's national ads!

**DISPLAY THE DECAL THAT  
BRINGS CUSTOMERS  
TO YOU!**



# SYLVANIA ELECTRIC

*Radio Tube Division, Emporium, Pa.*

MAKERS OF RADIO TUBES; CATHODE RAY TUBES; ELECTRONIC DEVICES;  
FLUORESCENT LAMPS, FIXTURES, WIRING DEVICES; ELECTRIC LIGHT BULBS

Sylvania Electric Products Inc.  
Radio Tube Division  
Advertising Dept., Room R-1606  
Emporium, Pa.

Gentlemen:

Please send, FREE, the following quantities of the Sylvania Serviceman's decals:

..... 8-inch size ..... 12-inch decals

Name .....

Company .....

Street Address .....

City ..... Zone # .....

State .....



# PROSPECTING FOR *Extra* SALES?

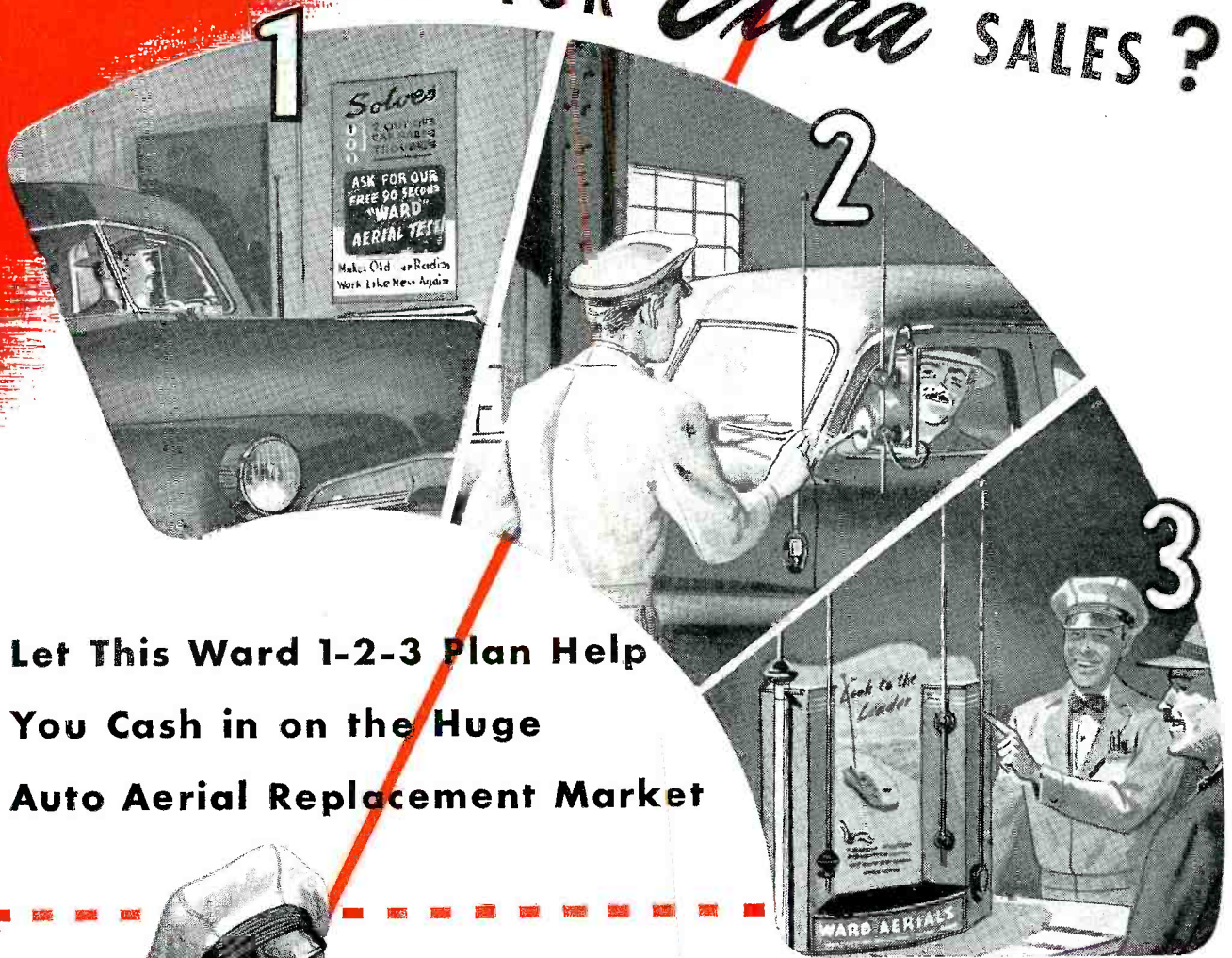

**Let This Ward 1-2-3 Plan Help  
You Cash in on the Huge  
Auto Aerial Replacement Market**



## **FAULTY AERIALS CAUSE 2 OUT OF 3 CAR RADIO TROUBLES**

Thousands of auto aerials in use today have become so badly damaged by weather, vibration and abuse that they might as well be junked!

To help you sell the two out of three who only need a replacement aerial to make their radios work like new again, Ward offers you a special package deal backed by a powerful barrage of national consumer advertising in the Saturday Evening Post, Collier's and the American Weekly! It includes: (1) A striking sign that catches customer interest, (2) A handy aerial tester that spots trouble in a jiffy, and (3) A smart display of four replacement aerials, a model for every make and model car.

Your profit is at least \$2.00 on every aerial, PLUS installation charge. The signs and display are free, you pay only for the aerials! Write today for details. Also, please send name of your parts jobber!

### **THE WARD PRODUCTS CORPORATION**

1529 EAST 45TH STREET, CLEVELAND 3, OHIO  
DIVISION OF THE GABRIEL COMPANY

IN CANADA: Atlas Radio Corp., 560 West King Street, Toronto, Ontario  
EXPORT DEPT.: C. O. Brandes, Mgr., 4900 Euclid Avenue, Cleveland 3, Ohio



Nationally advertised in  
The Saturday Evening Post  
Collier's • The American Weekly

# WARD

# *Aerials*

WORLD'S LARGEST PRODUCER OF AERIALS FOR CAR AND HOME



# ANNOUNCING RAYTHEON BANTAL TUBES

A New and Better Tube

No Extra Cost!

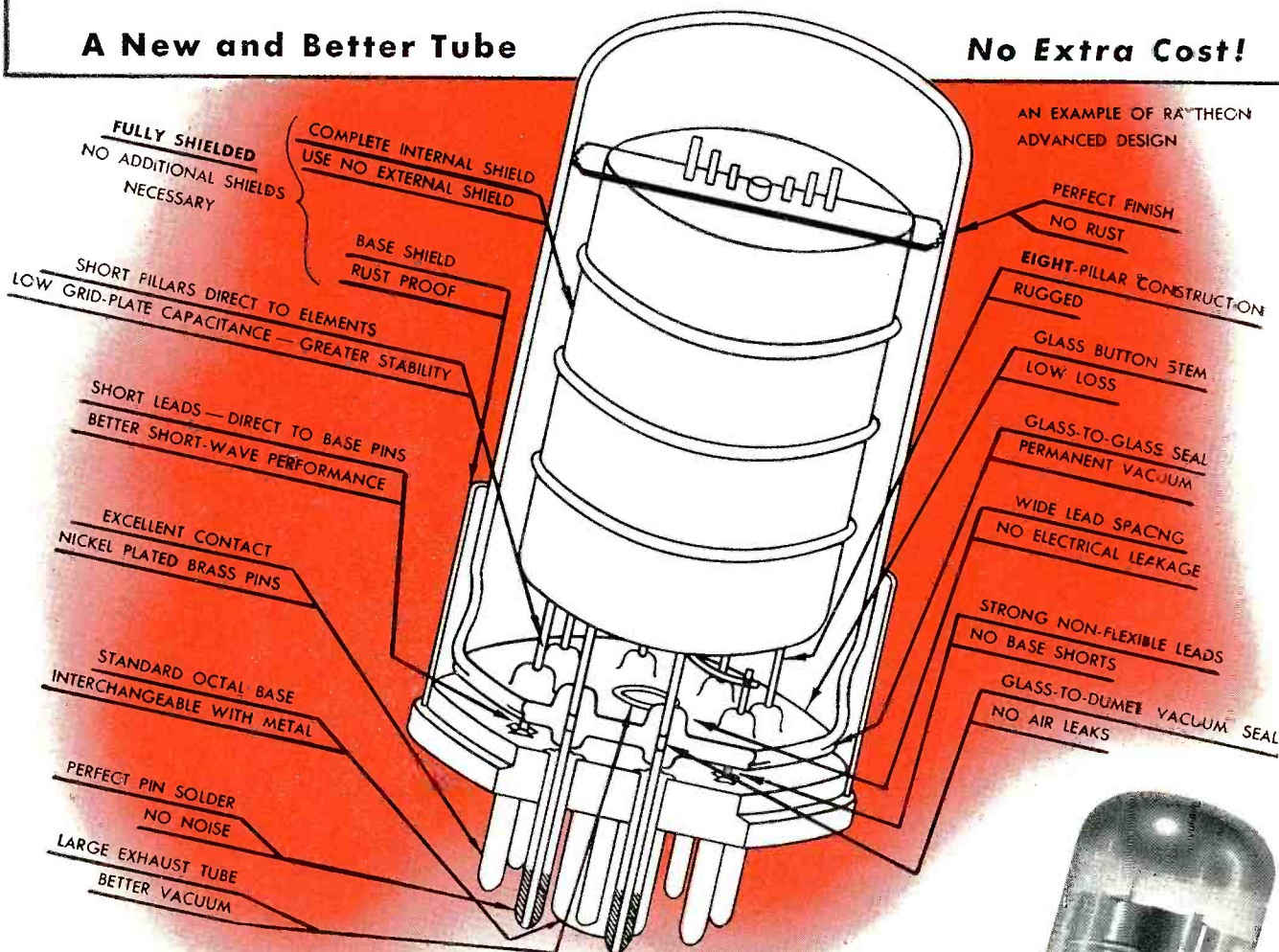

Just think! All the above design improvements and construction advantages in *one* tube—the RAYTHEON BANTAL tube.

- **Rugged Eight Pillar Construction**
- **Completely Shielded Internally** — No external shielding hardware or installation labor! Increases your service profit!
- **Made In Eight Popular Types** 6SA7GT-6SJ7GT-6SK7GT-6SQ7GT-12SA7GT-12SJ7GT-12SK7GT-12SQ7GT
- **Superior Performance Assures Customer Satisfaction And Repeat Business**

• **All At No Extra Cost!**

Your Raytheon Distributor — sponsor of the famous Bonded Dealer-Service Program — is now delivering Bantal Tubes.

Look for this distinctive marking on the Raytheon Bantal Tube. The 12SK7GT Tube illustrated replaces ordinary "GT" and Metal 12SK7 Tubes. **Only** the Bantal Tube is needed in stock!



**RAYTHEON MANUFACTURING COMPANY**

RADIO RECEIVING TUBE DIVISION

NEWTON, MASSACHUSETTS • CHICAGO, ILLINOIS • LOS ANGELES, CALIFORNIA

RADIO RECEIVING TUBES • SPECIAL PURPOSE TUBES • TRANSMITTING TUBES • HEARING AID TUBES





## EQUALLY MATCHED

Split the reed assembly of a Mallory vibrator down the middle and the two halves will match each other so accurately that no scale made will register a significant difference. This precise distribution of weight is a major factor in assuring accurate output, reliable operation and long life.

### *Mallory Vibrators Make the Best Replacements*

Such careful manufacturing makes Mallory vibrators free of bounce and chatter and dependable in starting. More of them are used in original equipment than all other makes combined. That's convincing proof

they are the best replacement vibrators for you to stock.

In addition to assured quality, Mallory offers the most complete line in the business. Mallory standardization permits 12 basic vibrators to meet 90% of your replacement requirements. But a complete line of 52 vibrators is available to meet virtually every vibrator need.

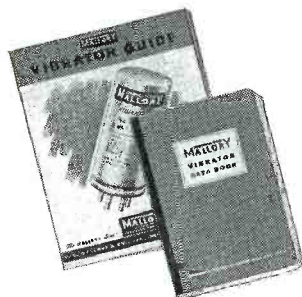

The Mallory Replacement Vibrator Guide is free. The Vibrator Data Book is \$1.00—from your distributor or by mail.

### Mallory "2448" Vibrator Deal

This deal gives you a handsome storage and display cabinet for your stock of vibrators, together with a selection of vibrators and buffer capacitors that will answer 75% of your requirements.



You pay only the service man's net price of \$24.48 for the six vibrators and twelve buffer capacitors. There is no charge for the attractive, convenient cabinet. Your Mallory distributor has them in stock for immediate delivery.

**MORE MALLORY VIBRATORS ARE IN USE THAN ALL OTHER MAKES COMBINED**

**P. R. MALLORY & CO. Inc.**  
**MALLORY**

CAPACITORS . . . CONTROLS . . . VIBRATORS . . .  
SWITCHES . . . RESISTORS . . . RECTIFIERS . . .  
VIBRAPACK\* POWER SUPPLIES . . . FILTERS

\*Reg. U. S. Pat. Off.

**APPROVED PRECISION PRODUCTS**

**P. R. MALLORY & CO., Inc., INDIANAPOLIS 6, INDIANA**



# RADIO SERVICEMEN!

# 19 PRIZES FOR 18 IDEAS

## HERE'S HOW EASY IT IS TO WIN

Right now, you may have a winning idea at work in your shop. An idea for a simple service tool which makes your work easier, faster, more profitable. Hytron wants to help make such needed tools available to all servicemen — at cost. You can cash in on your idea easily — and also help the other fellow.

Simply obtain an official entry blank from your Hytron jobber — or write us. Answer a few simple questions on the blank. Then include a sketch with constructional details — or a photograph — or a model of your proposed tool. Mail

to Hytron Contest Editor. The tool should be simple, practicable, durable, compact, easy and economical to manufacture. Examples: Hytron Tube Tapper and Miniature Pin Straightener.

That's all there is to it. Nothing to buy. Nothing difficult. No fancy writing. And could you use one of those beautiful deluxe test equipments — or one of those crisp new Savings Bonds! Check the easy rules. Get an official entry blank today for full details on how to win. Send in as many entries as you wish — in any or all six contests. Everyone wins a Tube Tapper. Your idea may hit the jackpot. Let's go!

### HERE ARE THE EASY RULES

**WHO** . . . Any bona fide radio serviceman who repairs radios for the general public and who lives in continental United States is eligible for these contests. Except employees of Hytron, their advertising agencies, and their families.

**HOW** . . . Get official entry blank from your Hytron jobber, or write us. Describe on blank your idea for a shop tool for radio servicemen. Include sketch and constructional details — a photo — or model. Make your proposed tool simple, practicable, durable, compact, easy and economical to manufacture (preferably to sell without profit at 50¢ or less) — like the Tube Tapper or Miniature Pin Straightener.

**WHERE** . . . Mail to CONTEST EDITOR, HYTRON RADIO & ELECTRONICS CORP., SALEM, MASS.

**WHEN** . . . There are six monthly contests. Opening and closing dates for each contest are the first and last days of each of the months from May through October, 1948, inclusive. The postmark date determines month of entry. Entries for final month's contest must be postmarked before midnight, October 31, 1948, and received by November 15th. At judges' discretion, unsuccessful entries in any month's contest may be re-considered among following months' entries. You may submit as many different ideas as you wish in any or all six monthly contests. Use separate blank for each entry.

**PRIZES** . . . See special listing of prizes.

**JUDGES** . . . Entries will be judged on originality, simplicity, practicability, durability, compactness, and ease and economy of manufacture. Judges will be: Sanford Cowan, Editor & Publisher of *Radio Service Dealer*; W. W. MacDonald, Managing Editor of *Electronics*; Oliver Read, Chief Editor of *Radio News*; Joseph Roche, Editor of *Radio Maintenance*; J. L. Stoutenburgh, Executive Editor of *Radio & Television Retailing*; Lewis Winner, Chief Editor of *Service*.

Judges' decisions final. Duplicate prizes in case of ties. No entries returned. Entries become property of Hytron, who may, at its option and by special arrangement with the entrant, pay the cost of a patent application (if the tool is patentable) with the understanding that Hytron is to have a non-exclusive license to manufacture, distribute, and sell the tool without royalties. Contests subject to all Federal and State regulations. Winners will be notified by mail. Grand prize winner will be announced in radio of service trade papers shortly after close of final contest. Prize winner list available approximately one month after close of last contest.

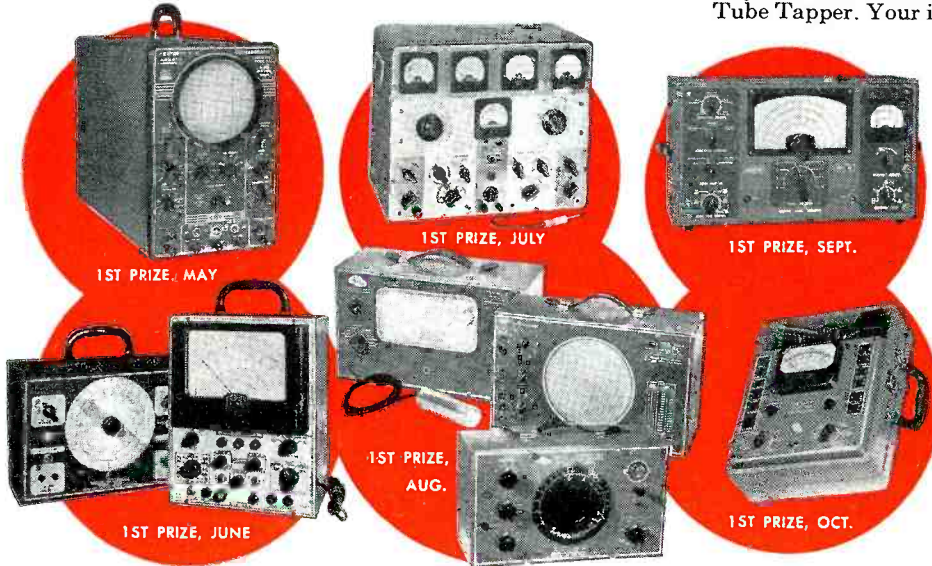

### HERE ARE SOME EXAMPLES



Hytron's Tube Tapper and Miniature Pin Straighteners show you the kind of tool wanted. Check off the qualities. Simple? Yes. Practicable? Usable time-savers. Durable? Built to last. Compact? Carry them in your pocket. Easy and economical to manufacture? Adapted to mass production. Tube Tapper a nickel; Pin Straightener 49¢ — both under 50¢. Tools associated with tubes preferred, but other original service tools also acceptable.

### HERE ARE THE PRIZES

#### First Prizes

- MAY DuMont Type 274 Five-Inch Oscillograph.
- JUNE Radio City Products Model 665-A, the "Billionaire", V-T Volt-Ohm-Capacity Meter, Insulation Tester; and Model 705-A Signal Generator.
- JULY Hickok Model 156A Indicating Traceometer.
- AUG. McMurdo Silver Model 900A "Vomax" Electronic Volt-Ohm-Milliammeter; Model 904 Condenser/Resistor Tester; and Model 905A "Sparx" Dynamic Signal Tracer/Test Speaker.
- SEPT. Jackson Model 641 Universal Signal Generator.
- OCT. Weston Model 769 High Frequency Electronic Analyzer.

Second Prize — Each Month \$50 U. S. Savings Bond  
 Third Prize — Each Month \$25 U. S. Savings Bond

#### Grand Prize.

\$200 U. S. Savings Bond — to contestant whose idea is judged to be best of the 6 winning monthly first prizes.

SPECIALISTS IN RADIO RECEIVING TUBES SINCE 1921

# HYTRON

RADIO AND ELECTRONICS CORP.

MAIN OFFICE: SALEM, MASSACHUSETTS





# The Answers TO EASY FM & TV SERVICING



The big profits in service lie in repairing FM and TV receivers — of which thousands are already in use. Fast, efficient service demands *visual alignment* of sound and video i.f. amplifiers. McMurdo Silver, world-famous builder of Laboratory Caliber Electronic Test Instruments, gives you the quick, accurate answers. Use 909 or 911 with any good 'scope, follow the simple, clear pictorial instructions and you'll master FM and TV alignment in "no time flat."

## 911 FM/TV SWEEP SIGNAL GENERATOR WITH CRYSTAL MARKER OSCILLATORS.

Covers 2 thru 226 megacycles in three bands upon accurately calibrated 3-range dial without band-switching! Output variable from zero to 1/2 volt. One graduated knob sets linear electronic FM sweep to anything between 40 Kc. and 10 megacycles—low enough for sharp communication FM to high enough for the biggest TV sets. Provides saw-tooth horizontal synchronizing voltage to 'scope at 2x power line frequency giving steady, stable mirror-image trace on your 'scope of i.f. — and r.f. — amplifier selectivity curves. Two panel knobs control amplitude of marker-frequency "pips" produced by two built-in low-drift 1 and 5 mc. crystal oscillators. These marker "pips" let you determine precisely correct pass-band in TV i.f. alignment . . . also serve as standard-frequency signals for checking calibration of *all* types of receivers, signal generators, etc.



\$78.50\*

## 909 FM/TV SWEEP SIGNAL GENERATOR.

Already America's most popular sweep signal generator. Model 909 is identical to Model 911 above except that it does not include crystal marker oscillators — uses your present AM signal generator to provide variable-frequency marker "pips" when desired. Using any good 'scope and following the clear, concise pictorial instructions, Model 909 makes you master of FM and TV visual alignment . . . the only method guaranteeing fast and perfect i.f. alignment. Thousands already in use by smart service technicians and in the laboratories and factories of FM and TV set manufacturers prove it to be exactly the instrument you have demanded. Convenient portable size matches all Silver LCETI — turns your shop into a modern service laboratory.



\$48.50\*

\*Prices slightly higher West of Rockies.

Send for 1948-1949 Catalog of NEW LCETI Test Instruments

OVER 37 YEARS OF RADIO ENGINEERING ACHIEVEMENT

*McMurdo Silver Co., Inc.*

EXECUTIVE OFFICES: 1240 MAIN ST., HARTFORD 3, CONN.  
FACTORY OFFICE: 1249 MAIN ST., HARTFORD 3, CONN.

LABORATORY  
CALIBER  
ELECTRONIC  
TEST  
INSTRUMENTS

**Specify the**



**1201**

**DELUXE ALNICO 5  
LOUDSPEAKER**

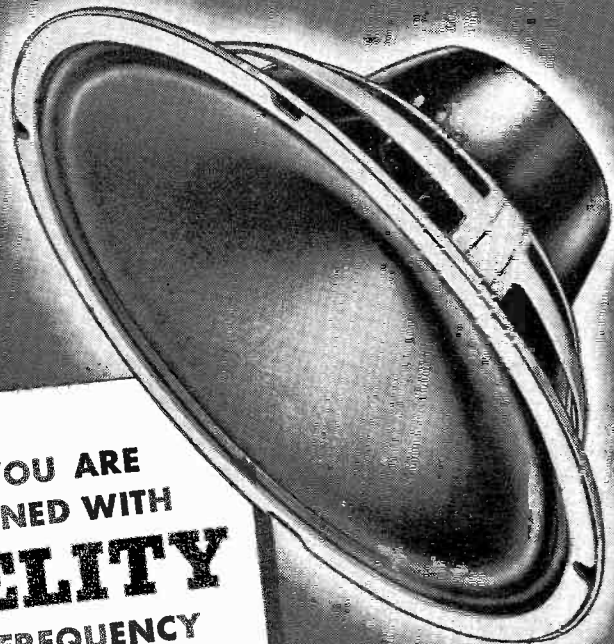

WHEN YOUR  
JOB DEMANDS  
**POWER**  
25 WATTS  
POWER HANDLING  
CAPACITY

WHEN YOU ARE  
CONCERNED WITH  
**FIDELITY**  
BROAD FREQUENCY  
CHARACTERISTIC  
50—13,000 CYCLES

EQUIPPED WITH  
THE FAMOUS  
**GENERAL ELECTRIC**  
ALUMINUM FOIL BASE  
VOICE COIL

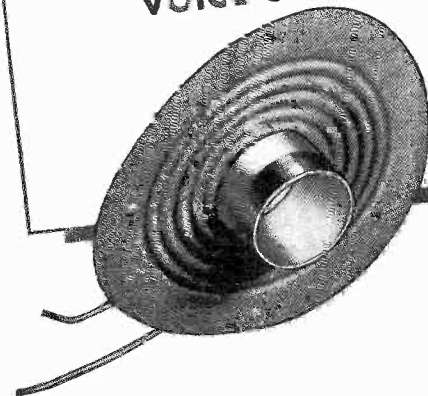

**P**OWER, fidelity and a price that will amaze you for a speaker of this exceptionally high quality—it's the G-E 1201.

It's a wide range speaker with the frequency response stretched out at both ends of the curve to give intense realism, smooth, full lows and "high fidelity." A curvilinear cone is employed to provide this extended frequency response. Alnico 5, 14½ ounces of it, gives high sensitivity and smooth response.

The moving parts in the speaker assembly are ruggedly designed to take high power without damage to the speaker in any way.

Note: Frequency response 50—13,000 cycles.

For complete information on this outstanding speaker write: *General Electric Company, Electronics Park, Syracuse, New York.*

**GENERAL**



**ELECTRIC**

169-G5



**SAVE TIME**  
do a **BETTER** job



## SANGAMO Type 30 Plastic Molded Tubular Paper Capacitors

Thousands of radio service men are enthusiastic about this easier-to-handle, easier-to-install tubular capacitor! Molded in a thermo-setting plastic—with capacity values permanently *sealed* in, and with no wax ends to melt out at high temperatures—they assure better characteristics, longer life, and more dependable performance.

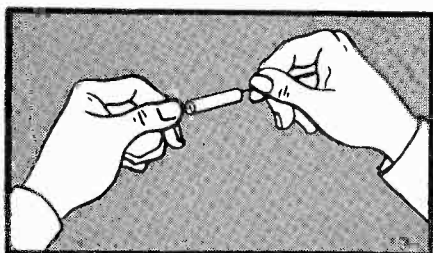

### **Easier to Handle**

The plastic molded case gives improved mechanical stability . . . does away with the necessity for delicate handling . . . leads are

so firmly fixed that it's almost impossible to *pull* them out!

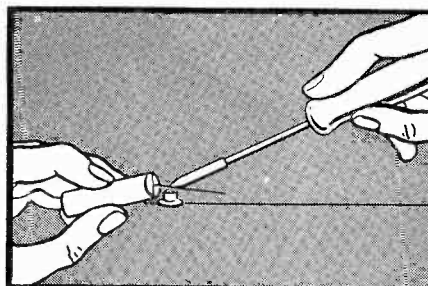

### **Easier to Install**

Sangamo Type 30 Capacitors can be used wherever ordinary wax-filled paper capacitors are now used. No more mess of running wax—heat from a soldering iron will not melt out ends—nothing can burn. This means easier installation, fewer damaged assemblies, and more jobs finished in less time.



Sangamo manufactures a complete line of paper, mica and silver capacitors. Write for Catalog No. 23B for full information.

SC484A

PAPER • MICA • SILVER • CAPACITORS

**SANGAMO**  
**ELECTRIC COMPANY**  
SPRINGFIELD • ILLINOIS

**RM-251** is a distinguished addition to the Jensen reproducer family. This "decorator-designed" Bass Reflex cabinet utilizes any fifteen inch Jensen loud speaker including the coaxial. Of sufficient size, it makes an ideal base for almost any television or receiver equipment.

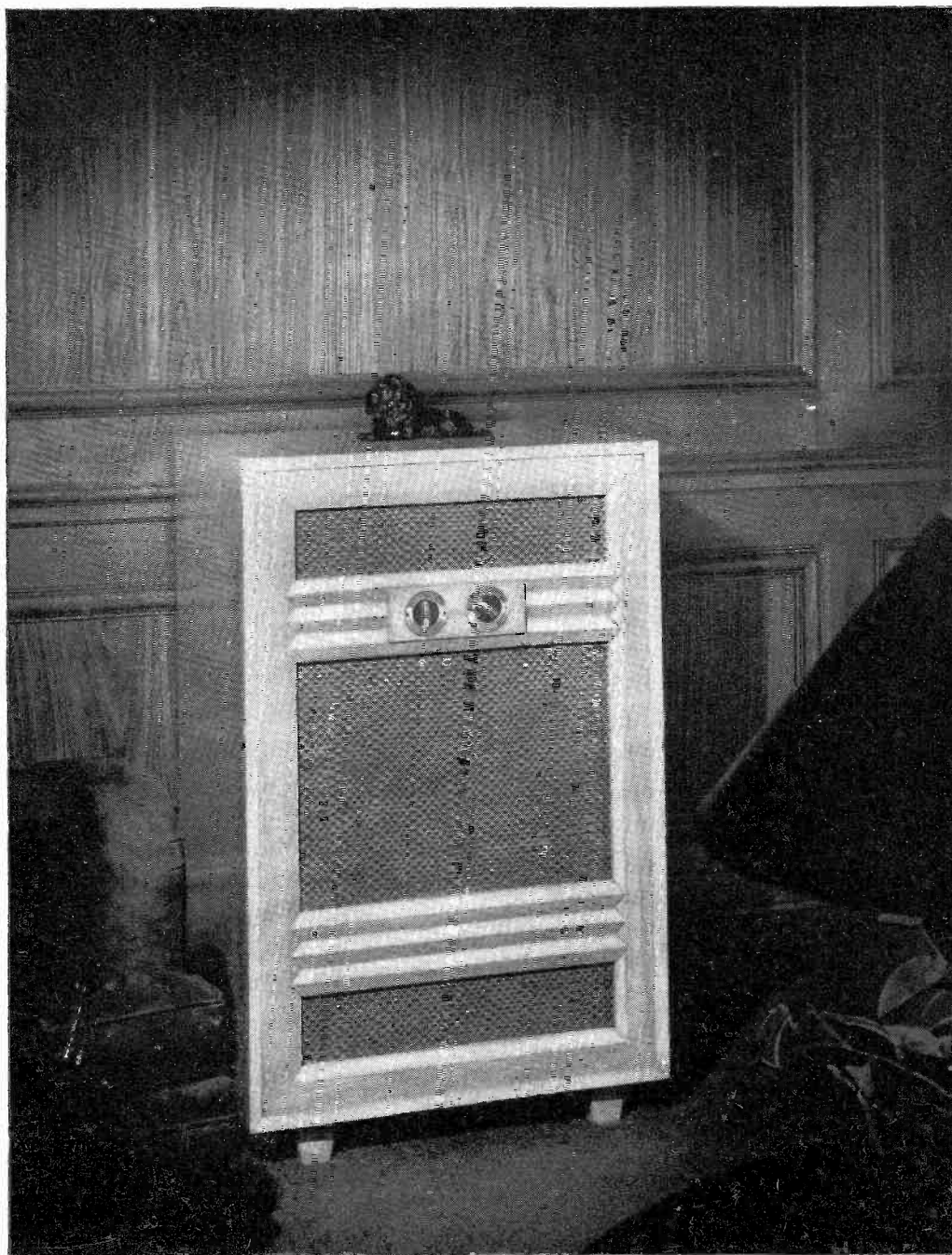

**Jensen**

**CUSTOMODE REPRODUCER**  
Chicago



# UNIVERSAL COILS

Another  
Philco  
First!

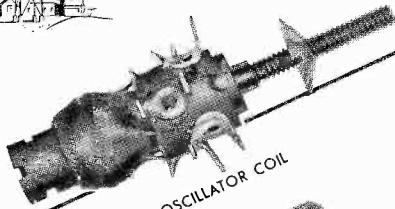

UNIVERSAL OSCILLATOR COIL

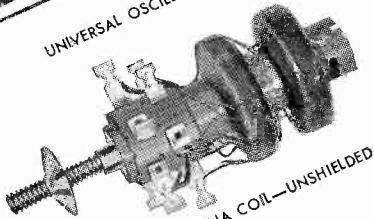

UNIVERSAL R. F. OR ANTENNA COIL—UNSHIELDED

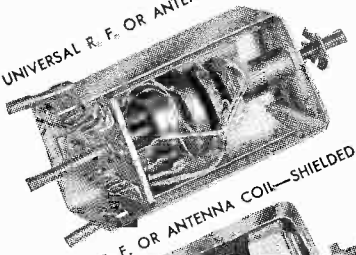

UNIVERSAL R. F. OR ANTENNA COIL—SHIELDED

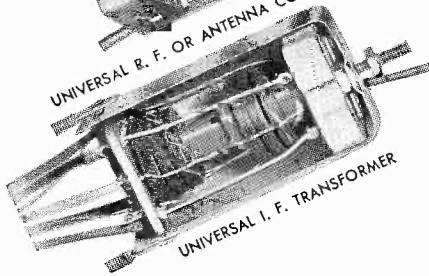

UNIVERSAL I. F. TRANSFORMER

## SHORT-WAVE BANDS

Only 2 coils are required to perform all the functions of antenna, R. F. and Oscillator Circuits.

PART NO. 45-6389-2 from 1.7 to 6 mc.  
SLIP-ON PRIMARIES FOR 45-6389-2  
LOW IMPEDANCE PART NO. 45-6389-1  
HIGH IMPEDANCE PART NO. 45-6389-3  
PART NO. 45-6389 FROM 6 to 18 mc.  
(INCLUDES PRIMARY)

These also have full range of adjustability and flexibility described for other types of Philco Universal Coils illustrated above.

PHILCO COMPLETELY COVERS STANDARD BROADCAST AND SHORT-WAVE RECEIVER COIL REQUIREMENTS . . . WITH **6** UNIVERSAL COILS . . . SAVING UP TO 90% OF STOCK NORMALLY REQUIRED FOR SERVICE REPLACEMENTS . . . REDUCING INVESTMENT . . . SAVING TIME . . . AND INCREASING SERVICE PROFITS.

At last! Coils that are *really* universal. Yes, ONE OF A KIND—and *only one*—for each basic requirement. That's Philco's newest contribution to better, quicker servicing of all makes of radios . . . UNIVERSAL COILS that save the service man time, trouble and expense. They simplify replacement work. They make it possible to service more sets with a stock of fewer types. Here's the answer to *all* coil replacement problems—from the world's largest designer, manufacturer and user of coils—Philco.

SEND FOR FULL INFORMATION TODAY

PHILCO CORPORATION  
ACCESSORY DIVISION  
PHILADELPHIA 34, PA.

Please send me complete information about Philco "UNIVERSAL COILS"

Name \_\_\_\_\_

Address \_\_\_\_\_

City \_\_\_\_\_ Zone \_\_\_\_\_ State \_\_\_\_\_

The New **PRECISION "612"** is your answer  
to **Economical, Positive, Tube and Battery Testing**

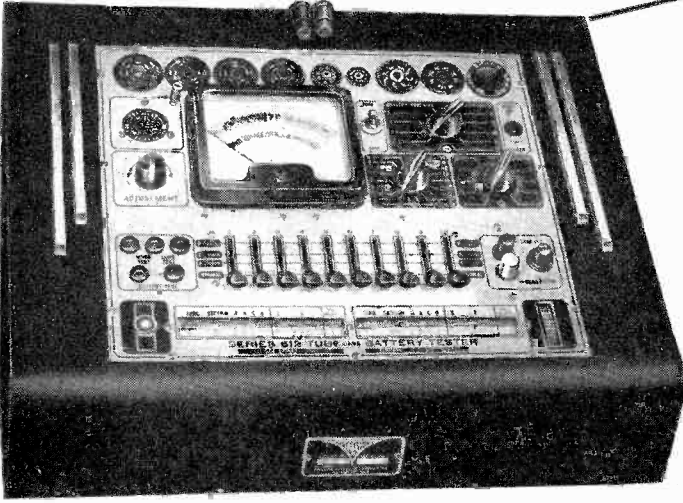

- ★ **Positive Free-Point Tube Testing**
- PLUS** ★ **Highest Practical Obsolescence Insurance**
- PLUS** ★ **Utmost Simplicity of Operation**
- PLUS** ★ **"Precision" Quality and Workmanship**
- PLUS** ★ **Moderate Cost . . . Impressive Design**

The new Series 612 is a modern, **free-point, lever-operated Cathode Conductance Tube Tester** representing the culmination of extended and intensive development in the field of modern tube checking requirements. It answers the ever-present need for **positive tube testing results at moderate cost**, with full conformity to "Precision's" high standards of workmanship, performance and quality components.

The new "600" line affords tube testing parameters based upon the time-proven emission testing principles as recommended by both tube manufacturers and R.M.A.; plus innumerable circuit features which render it incomparable amongst instruments in its category.

**612-C** (illustrated). In modern chrome-trimmed, Counter type cabinet. Dull black ripple finish on heavy gauge steel. 16 x 13 1/2 x 7", sloping to 3" at front.  
Complete: - \$63.95

**612-P**-In hardwood, Portable case with tool compartment. Size 12 x 13 x 6" Complete: - \$61.95

**612-MCP**-Open style Metal Case Portable, fine dull black ripple finish on heavy gauge steel. Size 10 1/2 x 12 x 6"  
Complete: - \$59.95

**612-PM**-In standard size Panel Mount 12 1/4 x 19" with dust cover. For rack cabinet or wall mounting.  
Complete: - \$61.95

**TUBE AND BATTERY TESTING FEATURES**

- ★ Tests all modern tube types including 7 pin Acorns, button 7 and Noval 9 pin types, dual-capped H.F. tubes, FM and TV amplifiers, etc.
- ★ Filament voltages from 3/4 to 117 volts.
- ★ Absolute Free-Point 10 element lever selection for both short and merit tests.
- ★ 4 1/2" wide vision meter. 2% Accuracy.
- ★ Dual HI-LO short-check sensitivity.
- ★ Individual Tests of Multi-Section Tubes including tuning indicators, gas rectifiers, oscillator-converters, etc.
- ★ Ballast Unit Tests.
- ★ Micro-Line adjustment - continuously variable.
- ★ Pilot and signal light tests.
- ★ Noise and Condenser test pin jacks.
- ★ Dynamic "under-load" test for all popular radio A, B, and C dry batteries.
- ★ Built-in, brass geared roll chart.
- ★ Anodized, deep-etched, heavy gauge aluminum panel.
- ★ Panel-mounted Fuse extractor Post.
- ★ Telephone type cabled wiring using plastic-insulated moisture resistant hook-up wire.

**SERIES 620 TUBE, BATTERY AND SET TESTER**  
RANGES TO 3000 VOLTS, 12 AMPERES, + 64DB, 10 MEGOHMS

A COMPLETE, PORTABLE, SERVICE LABORATORY providing every essential feature for general purpose test and check of modern radio and electronic equipment.

Incorporates the identical tube test circuit and battery testing features of the Series 612, (described above) PLUS a complete A.C.-D.C. Multi-Range Circuit Tester of 1000 ohms per volt sensitivity.

The Series 620 is available in the same four model types as described for the series 612 (above)

620-C - Counter Cabinet.....Net Price \$84.30  
620-P - Portable Case.....Net Price \$82.30  
620-MCP - Metal Case Port..Net Price \$80.30  
620-PM - Panel Mount.....Net Price \$82.30

- CIRCUIT TESTING FEATURES**
- ★ 5 A.C.-D.C.-Output Voltage Ranges: to 3000 volts.
  - ★ 5 D.C. Current Ranges: to 12 Amperes
  - ★ 3 Resistance Ranges: self-contained; to 10 Megohms.
  - ★ 5 Decibel Ranges from -12 to +64 DB.
  - ★ Full rotary Range and Function Selection.
  - ★ 2 pin jacks serve all standard ranges.
  - ★ 1% Wire-wound and Metallized Resistors.
  - ★ 400 microampere 4 1/2" Meter. 2% accuracy.
  - ★ All Circuits Insulated from power line.

**SEE** these new "Precision" Test Instruments now on display at all leading radio parts and equipment distributors, or write directly for the Precision 1948 catalog describing the full Precision line of quality Electronic Test Instruments.

**PRECISION**  
TEST EQUIPMENT

*Standard of Accuracy*

**PRECISION**  
APPARATUS COMPANY INC.  
92-27 HORACE HARDING BOULEVARD  
ELMHURST 5, NEW YORK





# Precision . . . .

The ease and grace of a figure skater is a manifestation of infinite skill and precision. The delicate mechanisms that make the RADIART VIBRATOR outstanding represent precision manufacture at its best. The skillful engineering . . . the finest quality materials would be of little value without the precision manufacture that makes a working body of material and design. This is the RADIART VIBRATOR . . . another of the reasons for its superiority. This is why Radiart is preferred everywhere by servicemen who know vibrators.

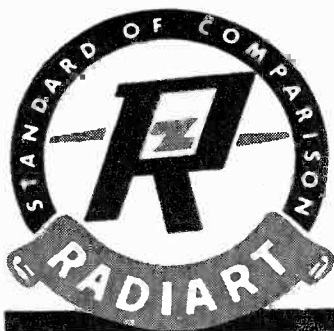
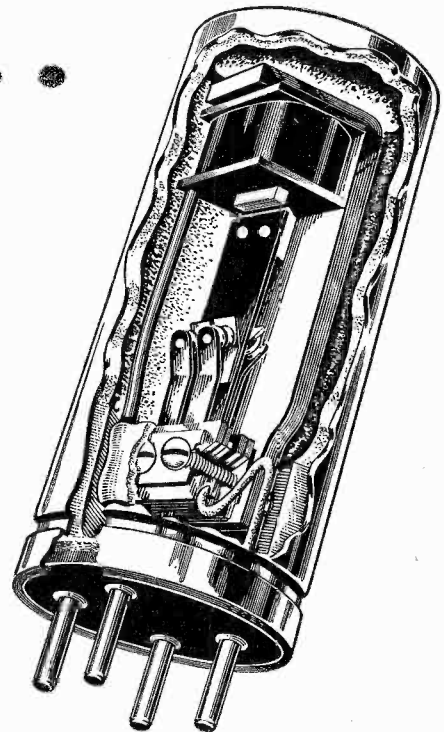

## The Radiart Corp.

CLEVELAND 2, OHIO  
EXPORT—SCHEEL INTERNATIONAL, INC.



# SUPER SERVICE

by P. Martin

**Brownie Radio Service is an example of the great opportunities for expansion in the radio service field. A service technician can, with patience, skill, and careful management, build his business to a large scale organization.**

**Y**ES, Radio Service can be big business, a lifetime business, as evidenced by Brownie Radio Service, Inc., of Cleveland, Ohio. From an ordinary service shop, Harold Brown and Morris Kopf, the owners, have built the business into one of the country's largest service centers. Hundreds of radios pass through this huge shop each week. An amazing degree of efficiency is demonstrated by this company in keeping the multitude of confusing details, usually associated with the handling of other people's property, down to an absolute minimum.

Ten departments are utilized in the activities of this business. Each one has a clearly defined job. This breakdown makes it possible for the service technicians in each department to become specialists in one branch of

service work and thus reach peak efficiency.

### The Office

The office consists of three girls for record keeping, bookkeeping, cashier, etc. The hundreds of telephone calls each day are expedited by a telephone switchboard and operator. Eight extension phones are provided throughout the various departments. The offices of Mr. Brown and Mr. Kopf are also part of the main office.

### The Table Model Department

There are six servicemen in the table model section. All of them are experts on table models and portables. A fast, efficient group, they keep up to date on the latest models and changes in models. Besides doing a

first-class repair job on table models, these men do wonders with old cabinets in bringing their beauty back to life, and an array of polishes and cleaners send all cabinets out sparkling and shining.

### The Record Changer Department

Two highly skilled record changer men using the most modern record changer tools and test equipment, make a quick job of the most complicated repairs or adjustments, on any kind of changer, player, or recorder.

### The Auto Radio Department

This department consists of three automobile radio specialists. The latest and best equipment and tools make the installation and repair of any



FIG. 1 M. E. KOPF, MANAGER, BROWNIE RADIO SERVICE, INC.

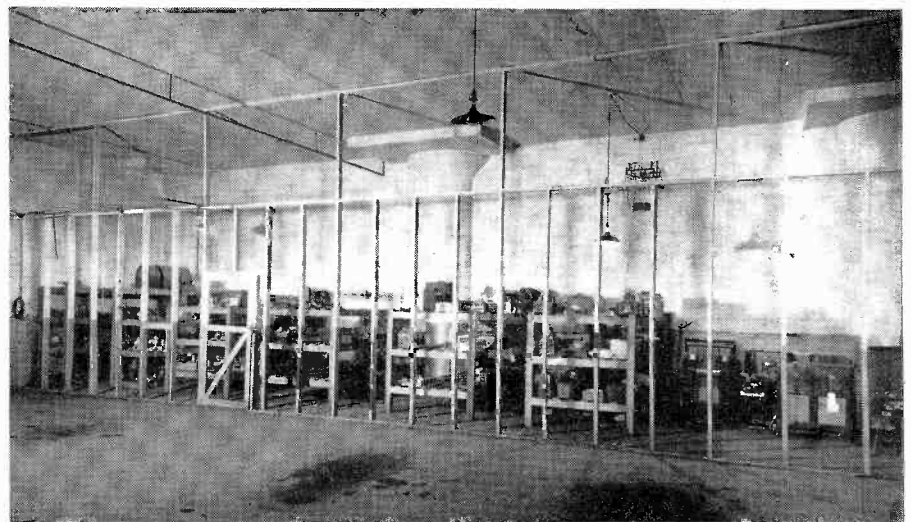

FIG. 2 THE RACKS BEHIND THE SCREENS HOLD RECEIVERS WHICH HAVE JUST BEEN BROUGHT IN OR ABOUT TO BE RETURNED. THE REST OF THIS LARGE ROOM IS USED FOR WORK ON AUTOMOBILE RADIOS.



auto radio a simple routine job for these experts. All auto radio work is done under cover and there is ample space for a dozen or more cars in the huge auto repair department. The police department, F.B.I., and other private agencies that use two-way radio take advantage of the skill and efficiency of these men.

### The Special Equipment Department

Here, one or two men, as the volume of work requires, service special equipment such as Solovox, electric organs, sound projectors, interphone and dictograph machines, electric guitars, microphones, etc. These men have to be good, and know what they are doing, as a mistake here might well ruin very expensive equipment. All the latest data and diagrams for this equipment, together with changes in models, are kept on file and there is no guesswork. Marine radios and amateur radios are also serviced in this department. For the convenience of this and the f.m. department, an insulated, shielded, soundproofed room has been built. Here, oblivious of the conglomeration of noises, squeals and howls of the service department proper, the men can take their equipment and jobs for testing and fine adjusting. Industrial concerns and individuals can take their unusual electronic devices to Brownie's confident of skilled service.

### The Outside Department

A fleet of cars and trucks, each manned with an experienced serviceman, pick up and deliver sets to all parts of the city of Cleveland. They install new radios for seven of the largest department stores, who are under contract to Brownie Radio for this work. They also install a.m. and f.m. antennas on private homes, and commercial buildings and stores. Each car or truck has a complete supply of tools, test equipment and repair parts along in order to give the customer home service if the job is a minor repair. A courteous, well regulated department.

### The F.M. Department

Brownie Radio Service, Inc., is manufacturing and installing f.m. antenna amplifiers. Many radio dealers have difficulty in demonstrating f.m. receivers. Brownie Radio makes it easy and profitable for them

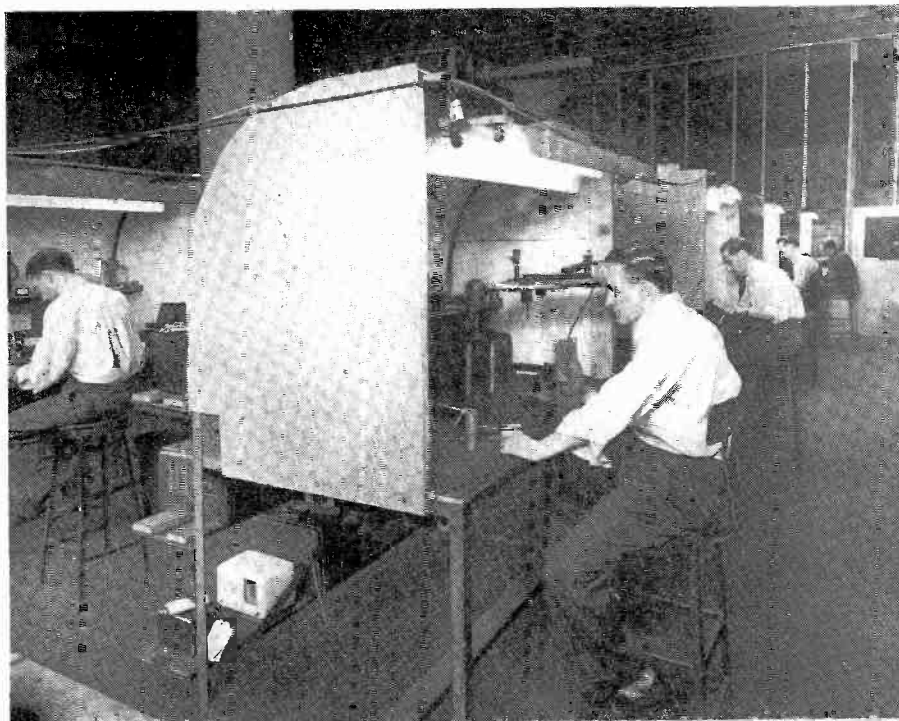

FIG. 3 A ROW OF REPAIR BENCHES AT BROWNIE. IN THE FOREGROUND A RECORD-CHANGER SPECIALIST IS AT WORK.



FIG. 4 PART OF THE OFFICE WHERE THOUSANDS OF ORDERS ARE HANDLED.

to give a good, high quality demonstration, by installing a multiple-receiver antenna system. These systems consist of an antenna and a series of amplifiers. The amplifiers cover all f.m. frequencies equally well, and feed a large number of individual receivers at once, without interference between receivers. These antenna systems are becoming so popular that they are being installed

in areas far from Cleveland.

### The Retail Department

Although a great deal of the radio service is done on a wholesale basis for department and furniture stores, and radio dealers, Brownie has a retail customer counter which handles the usual neighborhood business. These customers are impressed by the

→ To Page 36

## Suggestions on the installation of noise filters and a chart showing suggested filters for various uses.

by Paul M. Miller

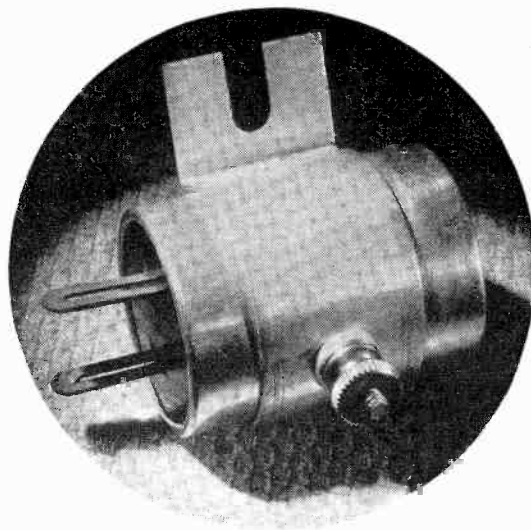

# INTERFERENCE

## PART II

**P**ROBABLY the most common "noise maker" in the home or office is the fluorescent light. The high-frequency oscillations generated by these lamps are radiated through the air and fed through the power lines to nearby radios and television sets.

The greatest intensity of the interference occurs when the lamp is first turned on and the starter goes into action. The frequency range of this disturbance makes it particularly annoying in the television and f.m. bands. Eliminating this interference *completely* often requires that some sort of screen be placed over the fixture to catch the radiation from the lamps and the metal fixture. It is usually not necessary to go this far since a suitable filter installed in the fixture will often prove to be satisfactory. Only one filter is required in a fixture, regardless of the number of lamps in the unit. Proper installation of the filters is important and can mean the difference between success and failure in removing the interference. In most filter units the container is the ground connection and great care should be taken to insure that a good low resistance connection is made.

The paint must be thoroughly removed from the area around the point where the unit will be bolted,

screwed, or soldered to the frame of the fixture. Choose a mounting point close to the place where the a.c. line leaves the fixture.

This will insure that no radiation from the starter will be induced in the line after it leaves the filter unit.

Ordinary capacity type filters should be installed across the line as shown in Figure 1. Capacitance-inductance filters are installed in series with the line as shown in Figure 2.

Chart 1 is a list of equipment and the filters recommended for use with each type of equipment given. Chart 2 is the key to the alphabetical listing used in Chart 1. Where two or more letters (A, B, C, etc.) of a single brand appear under one manufacturer's name it is only because there will be different current requirements or power ratings and varying intensity levels on each job, and it will be up to the serviceman to select a filter that comes as close to the estimated ratings as possible.

Low current units are used with vacuum cleaners, hair dryers, fans, sewing machines and other devices which do not use a great deal of power.

Oil burner motors, stoker motors and the like require units capable of carrying considerably higher current. Units are available which can be

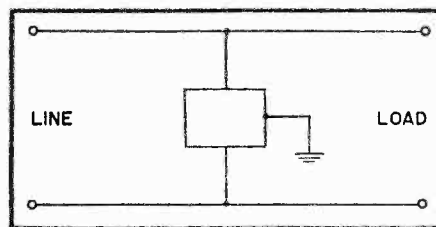

FIG. 1 CAPACITY-TYPE FILTERS ARE CONNECTED DIRECTLY ACROSS THE LINE AS SHOWN ABOVE.

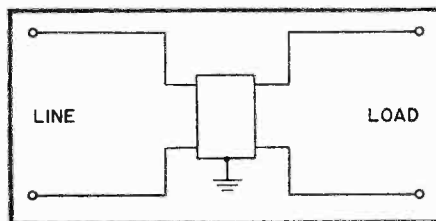
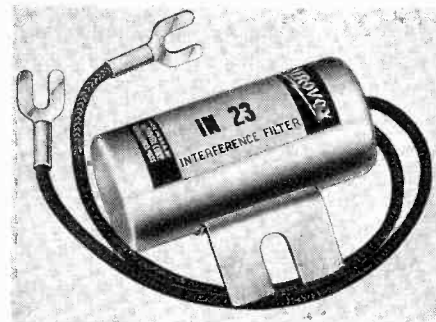

FIG. 2 CAPACITANCE - INDUCTANCE FILTERS ARE CONNECTED IN SERIES WITH THE LINE AS SHOWN ABOVE.



THE AEROVOX TYPE IN-23 IS A CAPACITY-TYPE FILTER DESIGNED FOR USE WITH FLUORESCENT LAMPS.



mounted on the motor or at the electric service box. As a rule, the most effective location is at the motor itself. Filters of heavy duty ratings are available in shielded boxes for BX cable connections.

For critical applications such as shielded rooms or test booths, or shielded demonstration parlors, it may be necessary to introduce shields between the input and output wiring, and in some cases to use two or more filters in series. A single filter of the high efficiency type (such as a single or twin Pi type) connected in series with one side of the power circuit to an interfering device is usually sufficient. In severe cases, a filter in each side of the power circuit may be necessary. In polyphase systems, a filter in each line is required.

### Locating Sources of Interference

There will be times when the serviceman is called on a noise job, and he finds that the interference is not being caused by electrical appliances or apparatus in the owner's home, and he must either experiment with filters in a "try 'em all" method at the receiver, or else go out and hunt up the source of the noise. He can knock on the neighbors' doors asking them if they happen to have an electric razor operating, or fluorescent lights burning, or what appliances they have operating at the moment.

Getting 100% cooperation with this method will require tact and courtesy on the part of the serviceman.

Another (and more satisfactory) method of locating the source of the interference is through the use of a portable radio of superheterodyne design. If the set has a.v.c., it is best to disconnect it. A pair of headphones should be added to the set as it may not be convenient to

have the speaker operating on all occasions, such as in a busy office, or on a heavily travelled street where other noise may prevent the serviceman from hearing well.

An output meter or tuning eye can be an added accessory if desired. The antenna may be a short automobile antenna rod, about 4 or 5 feet long, with or without a small loop on the end. Either one will do the trick, although a small loop added to the end of the pole will increase the directivity of the antenna. Swinging the antenna and set around will give the direction of the source of the interference. Walking toward the source should increase the noise level and the reading on the output meter.

Connecting the antenna to an electrical outlet through a small condenser will give an indication of the presence and strength of any interference coming in this way.

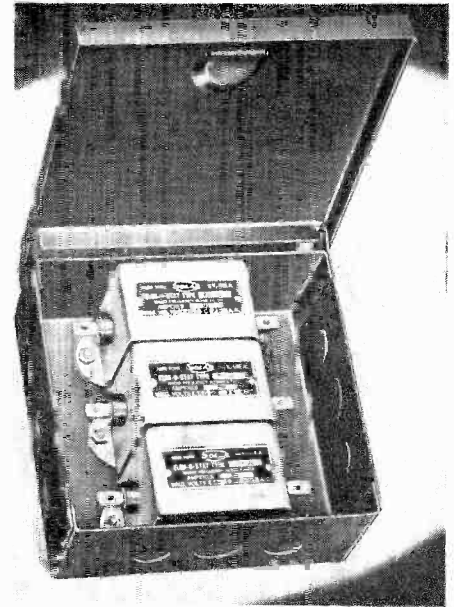

SOLAR ELIM-O-STATS MOUNTED IN AN ELECTRICAL SERVICE BOX. THESE ARE HEAVY DUTY UNITS.

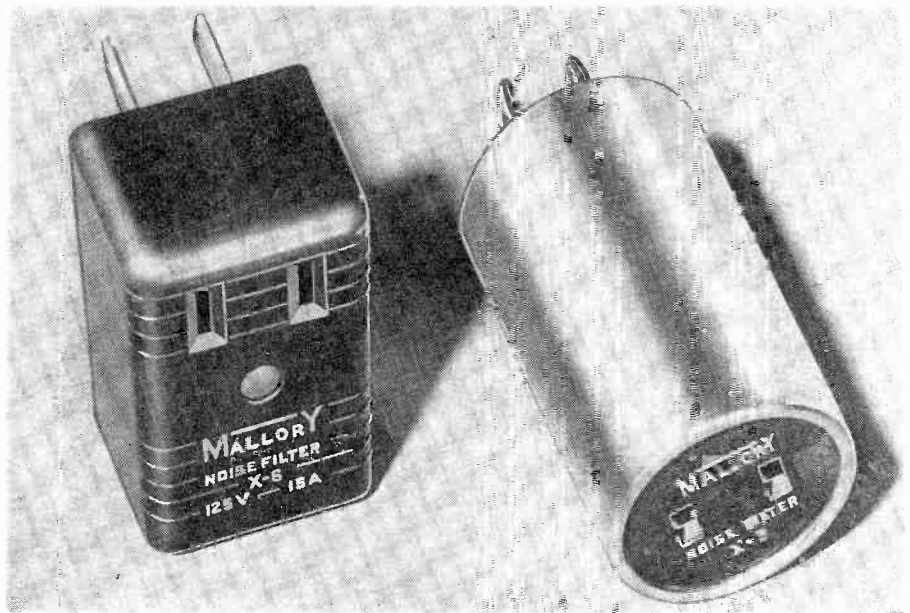

TWO NOISE FILTERS FOR USE WITH SMALL ELECTRICAL APPLIANCES. THESE UNITS ARE MANUFACTURED BY P. R. MALLORY AND CO.

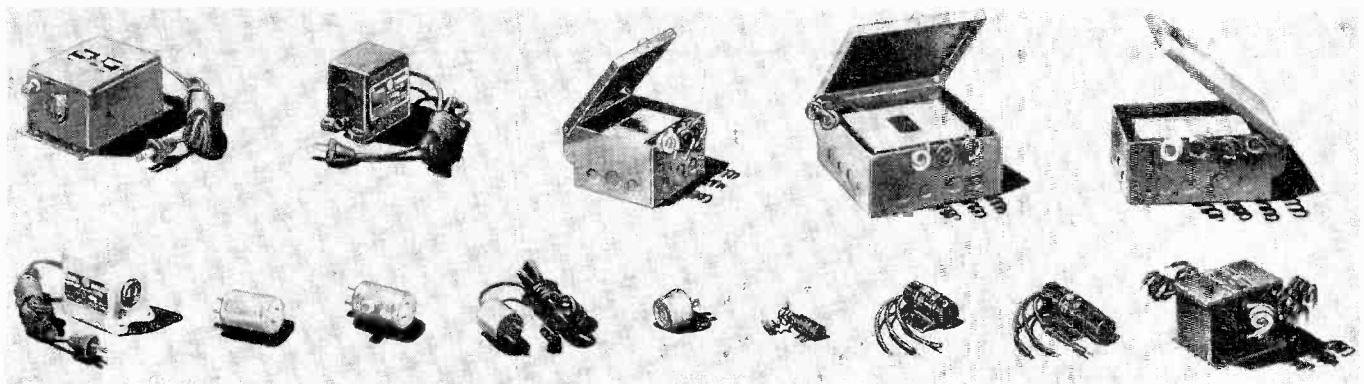

A GROUP OF INTERFERENCE FILTERS MANUFACTURED BY CORNELL-DUBILIER. LIGHT AND HEAVY DUTY UNITS ARE SHOWN WITH MOUNTINGS SUITABLE FOR THE USE TO WHICH THEY ARE TO BE PUT.

## CHART 1

	Cornell Dubilier	Continental Carbon Co.	Solar	Sprague	Mallory
Adding Machines	E A	B A	J	G A	A
Addressing Machines	E A	B A	J	G A	A
Air Conditioners	E	B	D	F	C
Barber Clippers	F	A	C	C	A
Battery Chargers					
(a) Mercury Arc	E	C	D	A	C
(b) Rotary type	F	C	D	A	C
(c) Vibrator type	E	B	D	D	C
Beer Pumps	E	B	K	E	C
Billing Machines	E	B	D	G	A
Calculating Machines	E	B	D	G	A
Cash Registers	E	A	D	G	A B
Compressors, Air	E	B	D K	A	E
Dental Machines	F	G A	G D	F	C
Diathermy Machines	B L	A B G	G J	A	C
Dictographs	F	H	G	F	A
Dishwashers	F	B	J D	A	C
Doorbells	A	E A	H G	C	A B
Drink Mixers	F	A	J D	E	A
Drills	F	A G	H	E	D
Electric Typewriters	F	F A	J	C	A B
Elevator Motors	B L	B	C	A	E
Fans	F	G A	H D	E	C
Flat Irons	A	B	J D	C	C
Food Mixers	F	A	H D	E	A
Floor Polishers	E	H	D	D	C
Fluorescent Lights	J	A	E	G	D
Fruit Juicers	F	B	J D	E	A
Generators	K B L	E	A B C	D A	D
Hair Dryers	A	A	D	E	A B
Heating Pads	F	B	J D	C	C
Humidifiers	F	C	A	F	B C
Malted Milk Shakers	B	A	J	E	B
Mangles	F	B	C	F	B
Massage Machines	F	B	J D	F	B C
Motors, Repulsions*	K B L	E	A B C	A	A B C
Series*	K B L	E G	H D	A	A B C
Neon Signs	E C L	B	J K	E A	D
Oil Burners	B	D	J	D A	C
Ozonators	F	A	D	F	C
Printing Presses	K	E G	H	A	C
Razors, Electric	H	A	J D	C	B
Refrigerators	E	B	J D	F	C
Rotary Converters	K	C	J	A	C
Sewing Machines	F	A H	G D	F	C
Sign Flashers	K L	B	K A	A	A B C
Stokers	K B L	B	K A	A	C
Vacuum Cleaners	F	H	G D	F	A
Violet Ray Machines	B L	B	G J	A	C
Washing Machines	F	B	J C	F	C
X-Ray Machines	B L	B	C J	A	C

\* For Single Phase Motors

If the interference comes in the portable radio in one direction and turning it 90 degrees either way eliminates the noise, then perhaps relocating the set owner's antenna will accomplish the same results. If the noise is not present in the receiver of the customer at the time the serviceman calls, he can inspect and put into operation every appliance in the home, one at a time, until the noise

appears.

### Interference Kit

Just as the brush salesman carries a kit of sample brushes which he thinks the housewife will buy, so does the modern noise specialist carry a kit containing an assortment of noise eliminators. Most of the service calls the serviceman encounters in his daily work relating to interference will consist of powerline interference

and the use of filters.

One of the most valuable and time saving devices in the kit will be the Aerovox Interference Analyzer Type ANI-37.

The Analyzer is a small metal box, containing combinations of capacity and inductance in various proportions and arrangements, that connects between the receiver and the electric outlet, and is rotated through its set-

→ To Page 28



# HEATER-CATHODE HUM

by Albert Loisch

The author outlines the cause of heater-cathode hum and the means by which it may be eliminated.

**E**LECTRICAL leakage between an a.c. operated heater and the cathode of a vacuum tube can introduce low-frequency voltage into audio amplifier circuits and cause objectionable hum when it occurs in a stage in which there is considerable gain. High-frequency circuits are also subject to hum, if they allow the low-frequency voltage to modulate the signal. The principal source of this hum is a minute leakage current which flows between heater and cathode as outlined. The flow of this current through the self-biasing resistor or the parallel combination of resistor and by-pass condenser applies a hum voltage between the grid and cathode of the tube. The path taken by the leakage current when one end of the heater is grounded is shown in Fig. 1. Here, the voltage across the heater, especially that between the high voltage end and ground, causes the current to flow.

Series operating conditions, with the heater not at ground, are shown in Fig. 2. The voltage across the other heaters between the tube and ground adds to the voltage causing leakage current to flow. It is known that heater cathode leakage current is essentially a thermionic emission phenomenon and that the flow of current is due to the emission of

negative charges (electrons) and positive charges (positive ions) from the insulation coating on the heater to the cathode sleeve. The capacitance between heater and cathode being of the order of 10 uuf, is too small to constitute a leakage path.

If the heater varies in potential with respect to the other electrodes, the same phenomenon can cause hum, by emission of charges to these electrodes. Hum from this effect occurs most frequently in a.f. amplifiers having a grid bias that is less than the highest voltage between heater and ground. To overcome hum troubles, heaters should not be operated above rated voltage, as hum doubles with only a six percent increase in heater voltage. If self-biasing circuits are used, the 60 cycle impedance should be as low as possible. This is attained by the use of low cathode resistance and high capacity by-pass condensers and is particularly important in the early stages of a high gain a.f. amplifier. Use of fixed-bias avoids this sort of hum. Tubes having comparatively small leakage, used as biased detectors, frequently hum as the cathode resistor is necessarily high and practical conditions require a small bypass condenser. The most satisfactory method of avoiding this

difficulty is to arrange the circuit so as to ground the cathode of the detector.

In series heater operation, the tube most susceptible to hum should be placed nearest ground. This is usually the detector tube in a.c.-d.c. receivers. The next tube to be given the preferred position near ground, is the converter, as this avoids modulation hum (not caused by heater cathode leakage). When a transformer is used, hum will be reduced by grounding the center of the heater winding. Hum can be reduced to a negligible value through the use of sufficient bias between heater and cathode to prevent the net voltage reversing. This condition occurs in infinite impedance detectors and certain cathode loaded circuits. Hum resulting from emission of charges from the heater to other electrodes, is reduced by decreasing heater temperature, by keeping the impedance of the electrode circuits low and by keeping the electrodes constantly biased with respect to the heater. Balancing or bucking hum in a receiver is sometimes resorted to in minimizing total hum. Heater cathode leakage should not be a part of a hum balancing system as it is too variable.

///

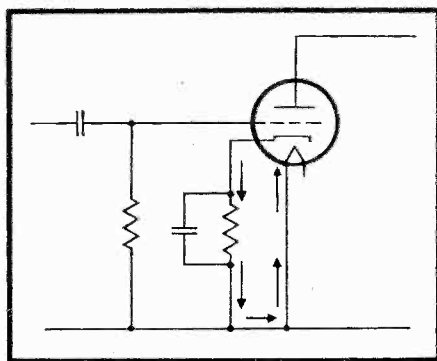

FIG. 1 THE ARROWS IN THE FIGURE ABOVE INDICATE THE PATH WHICH THE CATHODE LEAKAGE CURRENT TAKES.

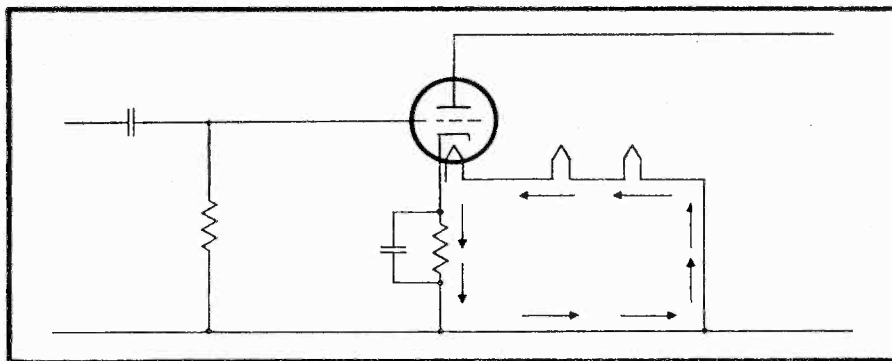
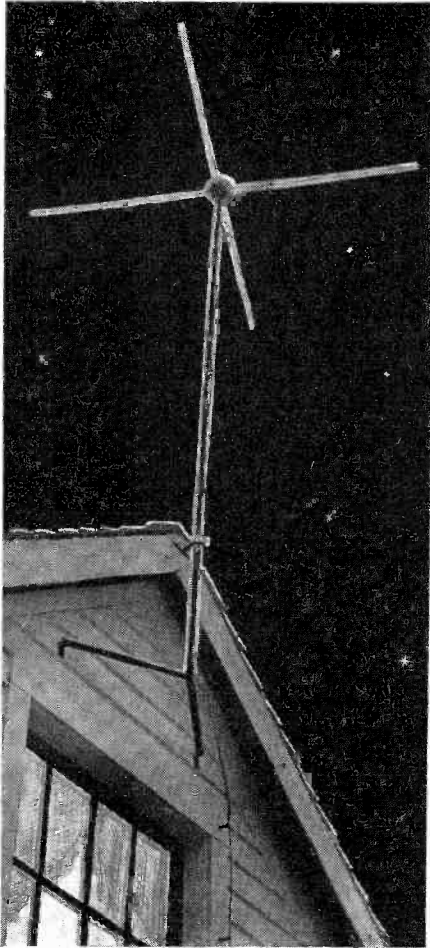

FIG. 2 WHEN RECEIVER FILAMENTS ARE CONNECTED IN SERIES, THE CATHODE LEAKAGE CURRENT FLOWS THROUGH ALL OF THE FILAMENTS. IT REACHES GROUND THROUGH THE BIAS RESISTOR OF THE STAGE IN WHICH THE CATHODE LEAKAGE IS TAKING PLACE.



# F M AND YOU

by J. R. Johnson

**A review of the f.m. situation as it affects the service technician. In many parts of the country, f.m. has reached the point where it represents an important percentage of the repair business.**

**F**REQUENCY modulation has outgrown its short pants and is fast reaching maturity. The time is already in sight when it will equal and surpass amplitude modulation. At present there are many more a.m. listeners than f.m. listeners. This situation is rapidly being changed as the following facts indicate:

1. The number of f.m. broadcasting stations has grown from the pre-war dozen or so to the over 400 now in operation.
2. Over 1000 f.m. stations are authorized and will be on the air by the end of 1948.
3. Over a million f.m. receivers were produced last year.
4. The estimated production figures for 1948 include from three to five million more f.m. receivers.

No service technician can overlook receivers which are coming out by the millions. What is more, f.m. coverage is no longer a "city only" proposition; nor is it to be confined to any particular area. Although in its experimental years f.m. was confined to population centers, it is really even better adapted to farm and prairie areas. FCC estimates place 84% of the country's population within reach of good f.m. reception by the end of this year.

Program material has steadily improved, especially since the recent agreement between the networks and the American Federation of Musicians. This agreement allows simultaneous transmission of musical programs on a.m. and f.m. Most of the popular a.m. programs are now available on the f.m. band.

Of course, there are still problems to be solved. For most of them the solution can easily be foreseen, and none will slow up f.m.'s progress. For instance, too many programs consist of ordinary records with limited fidelity and annoying needle scratch. As listeners become more and more numerous, money will be available to replace many of these programs with "live" talent.

## Technical Importance

Where does the service technician fit into all this? He has a tremendously important role. He is the only real contact between the manufacturer and the set owner. Hundreds of new and different things about f.m. must be explained to the customer. Antenna selection and erection assume much greater importance than

they have in the past. Circuits operating at high frequencies necessitate critical adjustments never necessary in a.m. broadcast receivers.

All of this means a better future for the progressive serviceman. The investment which the public is making in f.m. receivers will far surpass that made in a.m. receivers and although the new receivers are more complex and harder to work on, the rewards of the competent technician will be greater.

## Evolution of F.M.

The triumph of the f.m. system is its victory over noise interference. Amplitude modulation was the first system used because of two important factors:

1. Early receiving circuits were so broad that "selectivity" in the sense that we know it today was unknown. Frequency modulation if used, would go undetected.

2. The first transmitting circuits were amplitude modulated anyway as a result of their design. For instance, spark transmitters produce a "damped" a.m. wave inherent in the design of the circuit. It is therefore only natural that first developments were along the lines of amplitude modulation. Expensive transmitters were installed all over the country and the great momentum in the use of a.m. has postponed, a little, the change from one system to the other. But now it's in full swing.

Major Armstrong obtained his first patent on f.m. in 1933. It is significant that this patent was the result of a twenty year search for a method to *eliminate static*. The elimination of static and random receiver noise is the main advantage of f.m., and the only one which is a product of the modulation method itself (from the receiver owner's standpoint). Other advantages result from the use of higher frequency transmission, which would probably have been introduced even without f.m.

## Why F.M. is Growing

Put the inherent noise suppression properties of f.m. together with the fact that it is transmitted on high frequencies and its advantages over a.m. broadcasting are tremendous. Here are the reasons for the change from a.m. to f.m.

1. *Noise rejection*. Most noise is equivalent to an amplitude modulated carrier, and contains only a small



quantity of frequency modulated components. F.m. signals can be passed through limiters, which remove the noise, without any interference to the modulation. Amplitude modulation would be distorted or destroyed by the limiting action, which removes the a.m. noise in f.m. receivers.

2. *Greater reliable receiving range.* Although a.m. stations are often heard at distant points (at night) their actual dependable coverage (in which signals are always the same) is relatively small, even when interference from another area is not a factor. This limitation is a result of the carrier frequency range used. In this range, 540 to 1600 kc., transmission takes place over two paths. The dependable path is a combination of direct wave (line of sight) and the wave component which travels along the surface of the earth and objects on the earth. This combination wave is called the "ground waves." Only extremely slight changes in strength are experienced with signals received over this path *only*.

Another path is used by low frequency signals. This is produced by the reflection of waves from a layer of ionized air some distance above the earth. At night these "sky waves" are reflected in such a way that they interfere with the ground wave because of a phase difference between the two signals. The sky waves vary in strength with time of day, time of year, and atmospheric conditions. Fig. 1 illustrates the ground and sky wave components of a radio signal.

Because of all this, the average reliable coverage of a.m. broadcast stations is only about twenty miles. Almost perfect reception is available much farther, but beyond the basic limit there are at least some times when there is fading or interference.

### F.M. Uses Only Ground WAVE

Frequency modulation broadcasts use the 88-108 mc. range. On these frequencies, the sky wave is not a factor. High angle radiation is either dissipated in, or goes through the ionized layer which reflects the low frequency signals. Thus only the ground wave components are used. Although the ground wave coverage is limited, it holds up very well to between 60 and 100 miles. Beyond this range, it is attenuated rapidly and does not interfere with stations in other areas, say 500 miles distant.

The resulting reliable coverage is especially good for those locations which are twenty to 100 miles from the station. Reception is not affected by fading and distortion or interference from distant stations after sundown.

3. *High fidelity reception.* A wider range of audio frequencies could be transmitted on the broadcast band with a.m.. But this is not possible, because the bandwidth allowed for each station would have to be doubled (the band is already extremely crowded). This increased bandwidth would increase the noise level, since noise is proportional to bandwidth negating any gain in quality obtained.

The first difficulty is taken care of by the allocations of the f.m. carrier frequencies. The bandwidths allocated are wide enough to allow a wide audio frequency modulation coverage (up to 15,000 cycles per second).

The second problem is solved by the inherent noise suppression qualities of frequency modulation itself. The solution is aided by the fact that at these frequencies lightning and other atmospheric noises have much

less effect, even on a.m. signals, than they do at the regular broadcast frequencies.

### F.M. Future for Service Technicians

The future of f.m. has been well planned. The Federal Communications Commission allocated channels in a logical manner to minimize interference and get the greatest benefit from the allotted band. Fig. 2 shows in chart form the a.m. broadcast channels and the new f.m. band channels. Notice that there are about the same number of channels, but that the f.m. channels are twenty times as wide. F.m. channels are being assigned by areas. For instance, New York metropolitan area, Philadelphia metropolitan area, etc. Channel frequencies in adjacent areas are to be staggered so that at locations in the "overlap" section midway between areas, two signals will not appear on the same channel.

F. m. networks are forming. One in particular is making rapid progress. It is called the "Continental

→ To Page 35

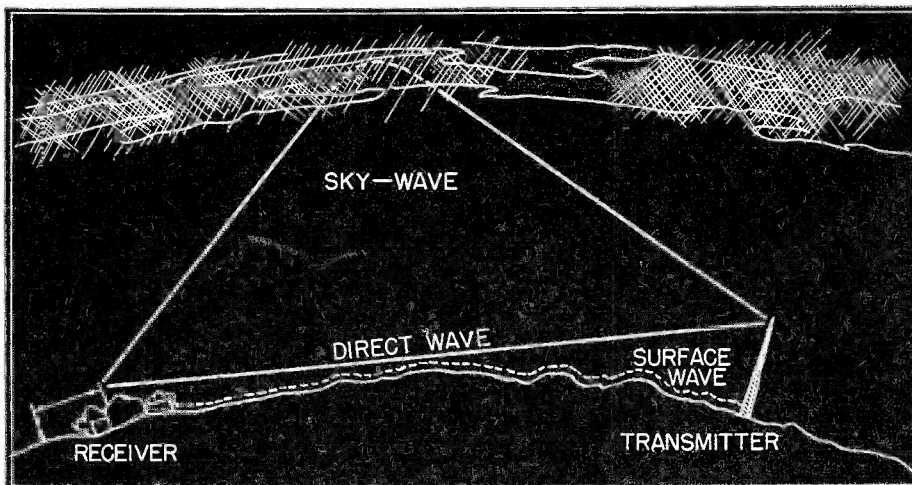

Fig. 1 At the a.m. broadcast frequencies, the transmitted wave is divided into three parts as illustrated above. At the frequencies used for f.m. broadcasting, the sky wave does not return to earth to cause interference.

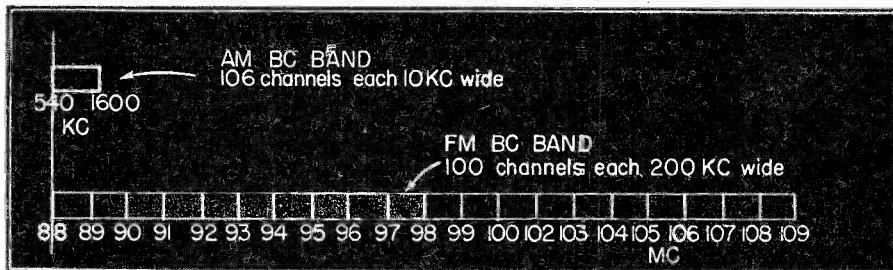

Fig. 2 The chart above illustrates the vast difference in the number of frequencies available in the a.m. band. The greatly increased frequency allotment for each station permits the transmission of the complete audible spectrum.

# TROUBLESHOOTING RECEIVER DISTORTION

PART 2  
by K. E. Stewart

## THE COMMON CAUSES OF DISTORTION. HOW THEY MAY BE LOCATED AND REMEDIED.

**M**OST modern receivers utilize degenerative, or negative feedback circuits to hold distortion to a minimum. Negative feedback tends to reduce both harmonic and frequency distortion. One or two, or even three stages are involved in the feedback chain. There are many methods used. A portion of the voltage may be fed back from the voice coil circuit, or the plate circuit of the output stage to a preceding stage as in Fig. 1, or in some cases degenerative feedback in one stage is accomplished merely by omitting the cathode by-pass condenser across all or a portion of the cathode resistor as shown in Fig. 2. Regardless of the method used, the improved tone quality which results,

is obtained at the sacrifice of amplification. A material loss of gain will result with excessive degeneration. Likewise a marked increase in distortion will result if for any reason the degenerative feedback circuit should cease to function.

In the case of a resistance-coupled push-pull stage, there will be some means of phase inversion in order that the signal voltages fed to the two output grids will be opposite in phase.

If the distortion is to be held to a minimum, the voltages must not only be opposite in phase but equal in amplitude. In checking the operation of the phase inverter, a modulated signal from a signal generator may

be fed into the r-f input of the receiver, or into any r-f or i-f stage for that matter; or an audio signal may be fed into the input of the audio amplifier of the receiver. (See Fig. 3) The audio voltages that will consequently appear at the two output grids may be checked and compared by either the use of an oscilloscope or a v.t.v.m. that is equipped with an r-f probe. These voltages should be of the same magnitude. A material difference between these readings may indicate a defective tube in the phase inverter socket, or a change in value of a load resistor in the phase inverter circuit.

Separate phase inverter tubes are not always used. Sometimes the driver stage serves as the phase inverter by having one of the output grids coupled to its plate and the other to its cathode as shown in Fig. 4. This serves the purpose of phase inversion because the voltages at the plate and cathode of a vacuum tube are essentially 180° out of phase.

In such a case, any difference in the values of the plate load resistor and the cathode load resistor will result in one of the output grids receiving a stronger excitation voltage than the other, causing distortion. A difference in the values of the grid load resistors of the output stage or the coupling condensers can have the same effect. In some phase inverter circuits, the grid load resistors are purposely of different values in order to apply equal signal excitation voltages to the two grids. Such a circuit may be found in cases where phase inversion is acquired by coupling one of the output grids to the screen-grid of the other stage as in Fig. 5. In any case the signal voltages at the

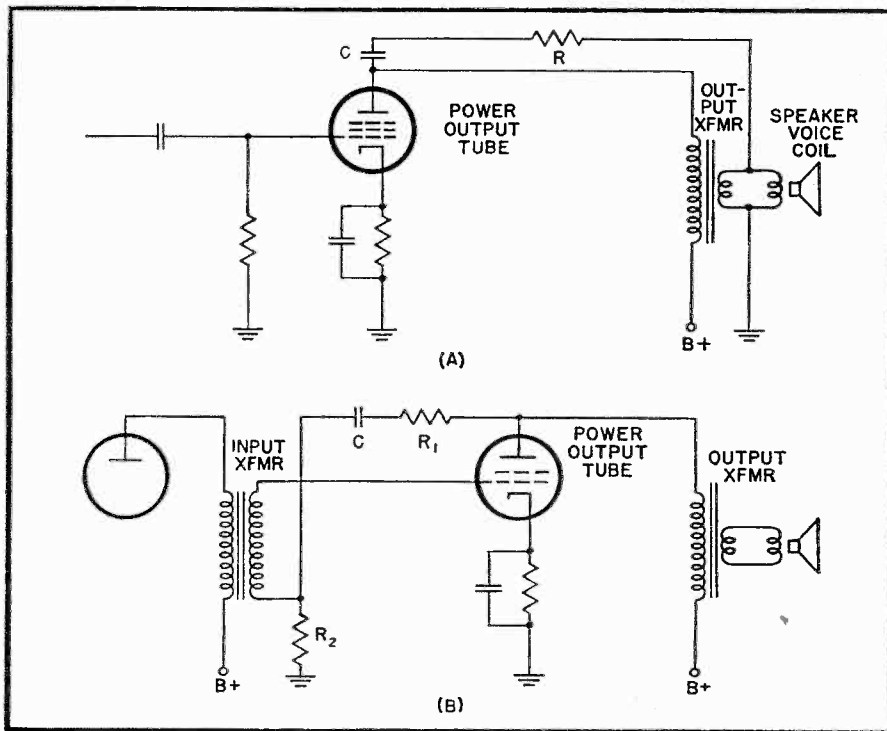

FIG. 1 THE CIRCUITS ABOVE ILLUSTRATE TWO COMMON METHODS EMPLOYED TO OBTAIN REGENERATIVE FEEDBACK. IN A, RESISTOR R AND CAPACITOR C CONSTITUTE THE FEEDBACK CIRCUIT. IN B, RESISTORS R1 AND R2 AND CAPACITOR C CONSTITUTE THE FEEDBACK CIRCUIT.



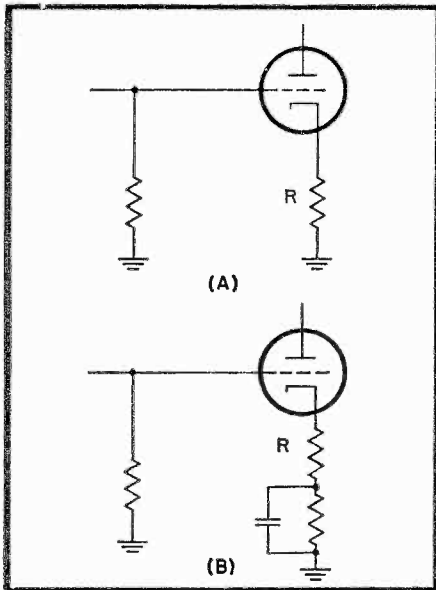

FIG. 2 NEGATIVE FEEDBACK VOLTAGE MAY BE DEVELOPED TO CROSS THE CATHODE RESISTOR OF AN AMPLIFIER BY OMITTING THE BYPASS CONDENSER AS SHOWN IN A OR BY PLACING THE BYPASS CONDENSER ACROSS ONLY PART OF THE CATHODE RESISTOR AS SHOWN IN B.

two control grids of the output stage should be equal.

### Midget Receivers

In some midget receivers a grid resistor of from 10 to 15 megohms will be found in the first a-f amplifier stage.

This grid resistor can be quickly located by first locating the coupling condenser which will be connected to the arm of the volume control potentiometer. The other end of this condenser will be connected to the grid of the first a-f amplifier and also to the grid resistor, R1 in Fig. 6. When these receivers are tuned to a strong local signal, there will be an unpleasant time lag, accompanied by distortion when the volume control is advanced for louder volume. Sometimes the value of resistor R1 will increase and become of such a high value that the distortion is always present. This time lag can be eliminated and the tone quality often improved by substituting a resistor of from 2 to 3 megohms.

A symptom sometimes encountered, especially in a receiver with resistance coupled audio stages, is a static-like noise due to the use of a resistor with too small a wattage rating. The wattage rating given to a resistor is based on the power necessary to raise the temperature of the resistor to 250° C. A resistor should be used which has a wattage rating of approximately twice the actual

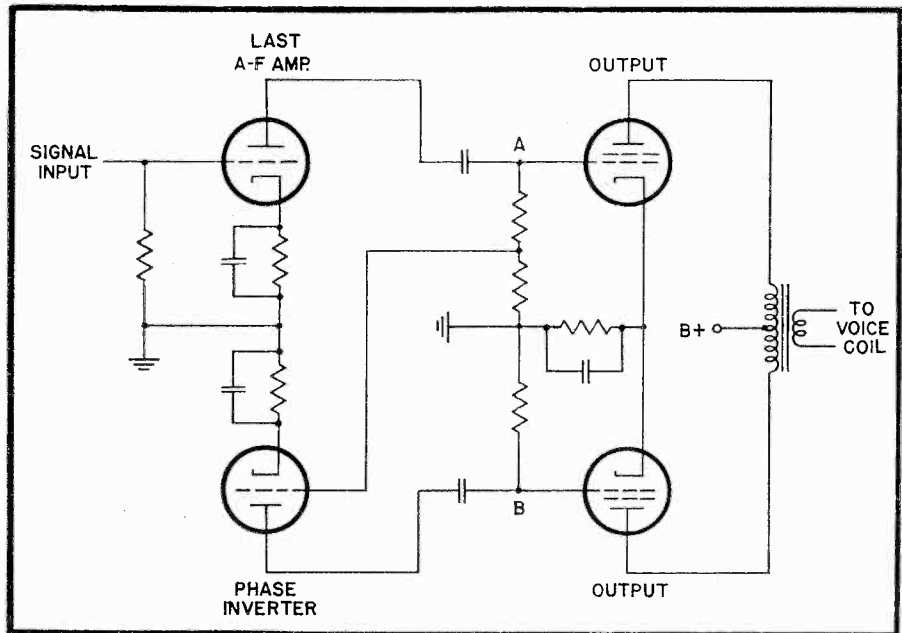

FIG. 3 PUSH-PULL OUTPUT STAGE AND PHASE INVERTER. THE OPERATION OF THE PHASE INVERTER MAY BE CHECKED BY COMPARING THE VOLTAGES PRESENT AT POINTS A AND B AS DESCRIBED IN THE TEXT.

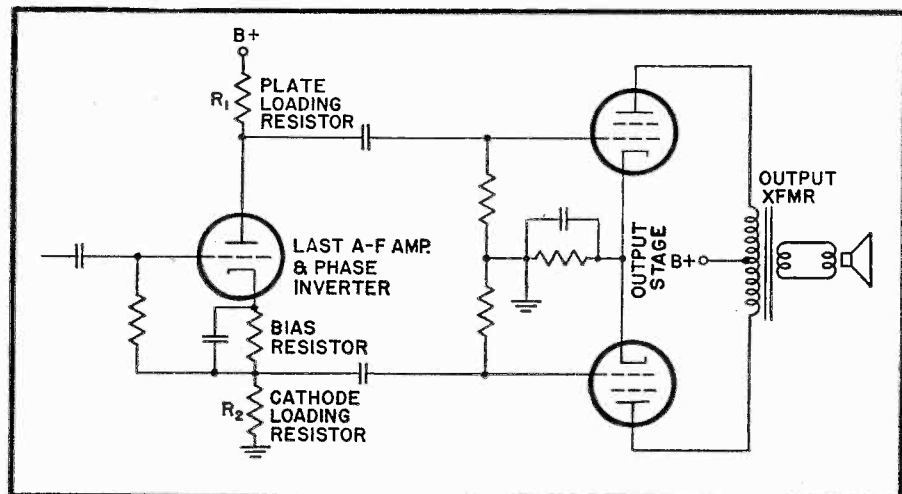

FIG. 4 A PHASE INVERTER USING A SINGLE TRIODE. IN ORDER FOR THE PHASE INVERTER TO OPERATE PROPERLY, RESISTORS R1 AND R2 MUST BE OF EQUAL VALUE.

power that it must dissipate.

### Bass Compensation

Most receivers employ some sort of bass compensation associated with the volume control circuit in order to compensate for the relative low sensitivity of the ear to the bass frequencies at low volume. A varying percentage of feedback takes place at different volume control settings. The lower the setting of the volume control the greater the amount of feedback, resulting in a greater amount of bass emphasis. The volume control resistor will be tapped at one or more points. It is extremely important, therefore that this control be of the correct value, and have the proper tapering, and when replacement is necessary it must be re-

placed with an exact duplicate of the original control.

The presence of an excessive amount of regenerative or positive feedback associated with one or more stages in a receiver is often the source of considerable distortion. Regenerative feedback may be due to many causes. The most common cause in the audio section is undesired coupling between stages due to lack of voltage regulation in the common voltage supply. The higher the gain of the audio stages, the more troublesome feedback becomes. The feedback may be great enough to cause sustained oscillations. Oscillation resulting from poor regulation will produce a sound in the speaker resembling the sound of a motor boat. Consequently such oscillation has in-

herited the name "Motorboating." The installation of r-c filtering, or isolating, networks in the individual B + lead of one or more stages will often remedy this condition, if such networks are not already incorporated in the circuit (See Fig. 7). In installing these networks the resistor should be kept as low as possible to prevent unnecessary lowering of the plate voltage. All of the by-pass condensers and power supply filter condensers should be checked first as the trouble usually lies in an open or partially open condenser which is already incorporated in the receiver. Any component which is capable of causing poor voltage regulation in the receiver can be the source of the trouble. The voltage regulation may be checked by tuning the receiver to a strong signal and taking voltage readings at various points along the distribution line with a v.t.v.m. The voltage at any point should be constant. Any fluctuation of the meter reading will indicate poor regulation. If the power transformer has been replaced by a

transformer with too low a rating, it may be necessary to replace it with a heavier transformer before good regulation can be acquired. One indication of an overloaded transformer is an excessively high temperature after the receiver has been on for sometime. This may be checked by placing one's hand upon the transformer. The temperature should never become great enough to cause discomfort to the hand.

Any filter choke that is associated with the power supply is as important in keeping the voltage regulation under control as are the filter condensers. If a choke has been replaced with one that is too light or with one of too low a reactance, poor regulation may result.

Oftentimes distortion will originate in the i-f stages as a result of excessive regeneration due to stray coupling between the grid and plate leads. This trouble is common with midget receivers. Sustained oscillations will usually result when a station carrier is tuned in, especially on the low frequency end of the dial.

Proper dressing of these leads will usually remedy this condition.

Loose shield cans often become a source of trouble. The symptoms are many and varying, such as squealing, howling, static noises, and other intermittent disturbances. An ungrounded or poorly grounded i-f can will also affect the alignment. Misalignment of the receiver will result in distortion. A marked frequency distortion will also result with the sharp tuning of i-f transformers that are designed for flat-top characteristics. The factory instructions should be followed in every detail when aligning a receiver.

### Oscillator

Frequently drift and instability of output voltage of the local oscillator may be the source of distortion in a superheterodyne receiver. The oscillator output will vary with the frequency in most receivers and in the case of the small midgets this variation may approach a ratio of

→ To Page 38

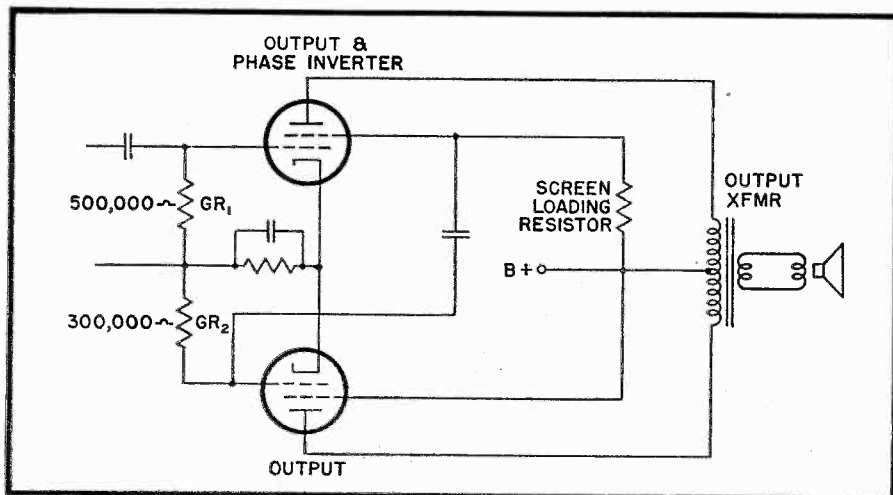

FIG. 5 PUSH-PULL OUTPUT STAGE AND PHASE INVERTER COMBINED.

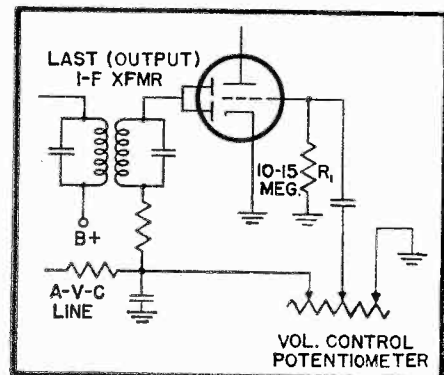

FIG. 6 AN INCREASE IN THE VALUE OF R1 WILL CAUSE DISTORTION AS DESCRIBED IN THE TEXT.

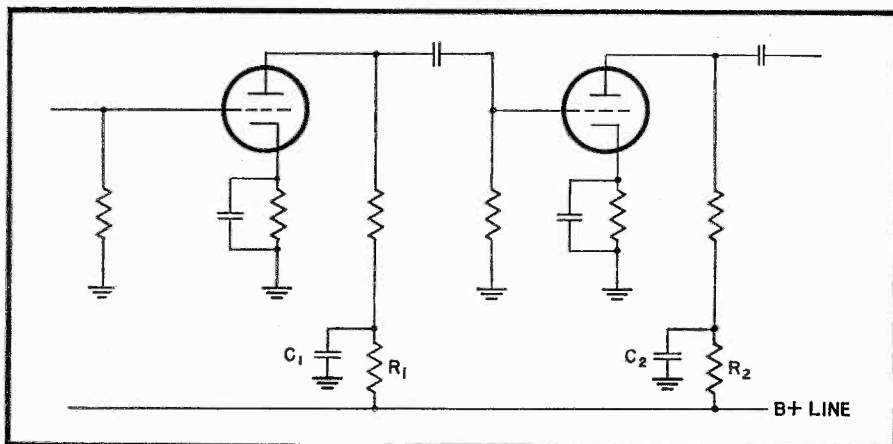

FIG. 7 THE INSTALLATION OF RESISTORS R1 AND R2 AND CONDENSERS C1 AND C2 WILL OFTEN REMEDY "MOTORBOATING".

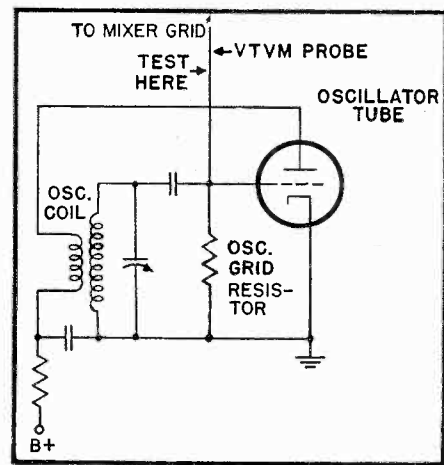

FIG. 8 AN OSCILLATOR MAY BE CHECKED FOR OUTPUT VARIATION BY PLACING THE R.F. PROBE OF A V.T.V.M. AT POINT A AND ROTATING THE TUNING CONDENSER THROUGHOUT ITS RANGE.

# PUEBLO

## SERVICEMEN'S ASSOCIATION

by R. C. Travers

Here is an example of how servicemen, no matter how small a group, can improve their position by forming an organization.

**T**HE Pueblo Servicemen's Association was formed in January, 1948. Composed of fourteen members, all of whom operate their own service shops within the confines of Pueblo or its suburban areas, this Association is unique in a number of ways.

To begin with every member must pass an entrance examination. This examination is made up of fifty true and false questions regarding radio circuits and set testing procedure. Every member submits ten questions which he feels might be usable for the examination. From the one hundred and forty questions thus submitted, fifty are chosen.

The second phase of the examination consists of deliberately rendering unplayable three radio sets, one a house radio, one an auto radio, and one a combination a.m.-f.m. radio. Again each member submits in writing five methods of making each set unplayable. From the suggestions submitted, a choice is made, and the three sets are placed in inoperative condition. Service members have a given time limit to make each radio set playable and in A1 order.

Servicemen who pass this examination with a grade of at least 85% receive a membership card good for Association privileges for a full year. In addition, their service shops are visited every three months by a committee of three Association men. Committee personnel is changed from quarter to quarter. Service shops are inspected for cleanliness and neatness of the entire establishment. No knowledge is given of committee visits.

Every member is granted certain privileges in return for a payment of weekly dues of \$.50. An Association library is composed of late technical manuals, and manufacturer's literature. Every member may withdraw

one book for a period of forty-eight hours at every weekly interval.

The Association has invested in a television kit and three separate test benches, each containing panel meters. In addition, a tube tester, Wheatstone Bridge, and Cathode Ray Oscilloscope are maintained in the laboratory. Every member may use the laboratory for three hours weekly and experiment to his heart's content with the video or other laboratory apparatus.

Moreover each week a lecture period is held on Friday evenings, at which time members each take the floor to discuss new set repair kinks,

experiments with f.m., a.m., and wire recorders, and industrial radio repair activities.

A wire recorder has been ordered for the laboratory, and members will be allowed to use it on the same three-hour basis weekly.

In addition, members pay a \$2.00 monthly charge for rental of laboratory and association headquarters. All members agree not to miss more than one meeting per quarter on pain of swift expulsion.

The members agree to charge a minimum of \$2.00 per service hour for house calls and \$1.75 for shop handling; to furnish customers with a

→ To Page 33



LEFT TO RIGHT—JOHN Q. RYAN, ASSOCIATION PRESIDENT; H. ALBERT WILLIAMS, VICE PRESIDENT; AND WILLIAM RAWLEY, SECRETARY AND TREASURER, ABOUT TO GO ON THE AIR FOR THE PUEBLO RADIO ASSOCIATION.





# Sell the leader

## Shockproof Webster-Chicago Nylon Needles with Knee Action

You'll be doing your customers a real favor when you sell them Webster-Chicago nylon needles with knee action. This exclusive design gives records extra protection—annoying surface noise, platter chatter and groove-hopping are virtually eliminated. The full range of highs and lows are reproduced. The clarity, smoothness and tone fidelity of instrumental and vocal recordings is remarkable, even old records sound better. If you are not already selling Webster-Chicago Nylon Needles write us for the name of the distributor in your locality.

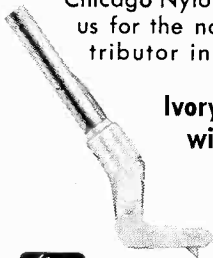

Ivory Nylon Needle with Knee Action

**\$350**



The Choice of Music Lovers

Made by the makers of Webster-Chicago Record Changers and Wire Recorders

**WEBSTER-CHICAGO**

5610 BLOOMINGDALE AVE., CHICAGO 39, ILL.

### CHART 2

Cornell-Dubilier	Cont. Carbon	Solar	Sprague	Mallory
A—IF-4 IF-5 IF-6	A—FO1DH LO2DH GO1DH	A—EA-157 EI-111 EI-112 EI-171	A—Filterol #1 Filterol #2 Filterol #3	A—X1 X3 X5 X6
B—IF-7 IF-15 IF-16	B—F505DH F1005DH	B—EB100 EB-101 EB-102	B—Filterol #4	B—Z2 Z4 Z6 Z8
C—IF-11 IF-12	C—R01DH R305DH	C—EB-103 EB-104 EB-105	C—IF-S1	C—LC5 LC10
D—IF-14*	D—OB14 OB15	D—ED-104 ED-105 ED-106	D—IF-11	D—Z8A
E—IF-18	E—F05D	E—EF-100 EF-103	E—IF-15	E—LB
F—IF-19 IF-21	F—F18	F—EF-101 EF-102 EF-104 EF-105	F—IF-21	
G—IF-20	G—G01D	G—EI-107 EI-109	G—IF-37	
H—IF-22	H—G14T	H—EI-113		
J—IF-24 IF-54		J—EN-184		
K—IF-25 IF-26		K—JUMBO		
L—IF-27 IF-28 IF-29	* 2 or 3 Phase			

### Interference—

#### Part II

→ From Page 20

tings until the greatest reduction of noise is noted, and the correct type of filter to install is read on the dial scale.

If the serviceman desires to con-

struct his own Analyzer, he can choose a variety of the most popular filters of the capacity and capacitance-inductance types of the same brand name and install them in a box, using his ingenuity to terminate the various leads in a switching arrangement that permits one filter at a time to be switched in series with one or both of the power lines, or across the line, whichever is required. ✓✓✓

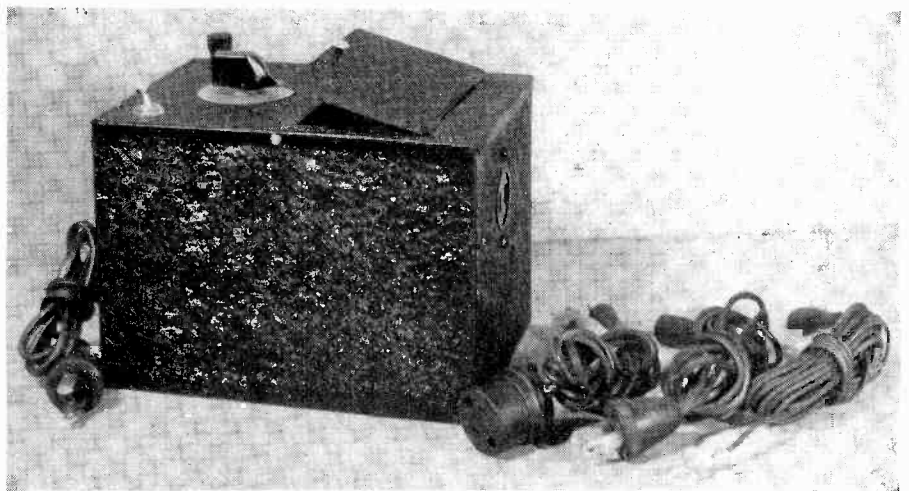

THE AEROVOX INTERFERENCE ANALYZER TYPE ANI-37. AN INSTRUMENT WHICH IS VERY HELPFUL IN DETERMINING WHICH TYPE OF FILTER WILL BE MOST EFFECTIVE IN ELIMINATING LINE NOISE.

# PHOTOFACT Publications Help You to Success!

Have more practical, useful, complete data than you can get anywhere else...

**READY NOW!**

## PHOTOFACT VOLUME 4

Includes First Three TV Course Installments!

Latest companion to popular Volumes 1, 2 and 3 — brings your file of post-war receiver service data right up to July 1948! Most accurate and complete radio data ever compiled... an absolute **MUST** for all Servicemen. Everything you need to know for faster, more profitable servicing, in handy, unified form. Includes: Exclusive Standard Notation schematics; photo views keyed to parts lists and alignment data; complete parts listings and proper replacements; alignment, stage gain, circuit voltage and resistance analysis; coil resistances; dial cord stringing; disassembly instructions; record changer repair instructions. Order Volume 4 today — it's the *only* service data that meets your *actual* needs!

- Vol. 4. Models from Jan. 1, 1948 to July 1, 1948
- Vol. 3. Models from July 1, 1947 to Jan. 1, 1948
- Vol. 2. Models from Jan. 1, 1947 to July 1, 1947
- Vol. 1. All post-war models up to Jan. 1, 1947

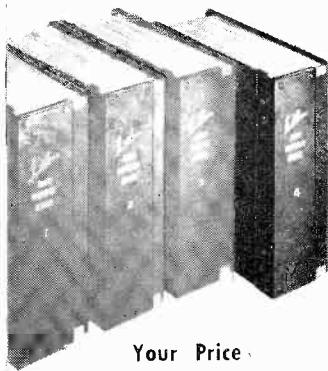

Your Price  
Each Volume,  
in Deluxe Binder  
**\$18.39**

## 1947 Automatic Record Changer Manual

Nothing like it! Covers more than 40 different post-war models. Absolutely accurate, complete, authoritative — based on actual analysis of the equipment. Shows exclusive "exploded" views, photos from all angles. Gives full change cycle data, adjustment data, service hints and kinks, complete parts lists. Shows you how to overcome any kind of changer trouble. **PLUS** — for the first time — complete, accurate data on leading Wire, Ribbon, Tape, and Paper Disc Recorders. 400 pages; 8½" x 11"; hard cover; opens flat. Don't be without this manual. **ONLY \$4.95**



## Radio Receiver Tube Placement Guide

The book that shows you exactly where to replace each tube in 5500 radio receiver models. Covers receivers from 1938 to 1947. Each tube layout is illustrated by a clear, accurate diagram. Saves time — eliminates risky hit-and-miss methods, especially when the customer has removed tubes from the set. A handy pocket-sized 192-page book, indexed for quick reference. You'll use it profitably every single day. Order several copies **ONLY \$1.25** for your bench and outside calls!



**FAMOUS \$500.00  
TELEVISION COURSE  
At No Extra Cost to You!**

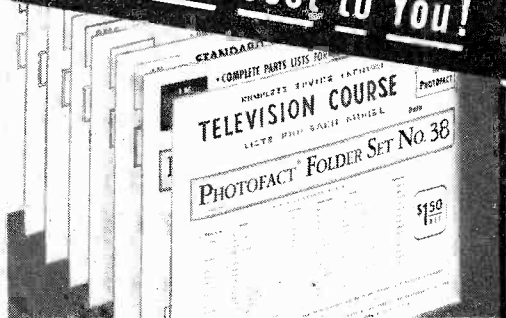

## NOW RUNNING IN CURRENT PHOTOFACT FOLDER SETS

Here's the first practical, successfully proved Television instruction for the Service Technician! Now — at no extra cost to you — you can prepare for profitable Television servicing without taking time off from your business. If you can service a Superheterodyne, the PHOTOFACT Course will teach you clearly and simply how to service a Television Receiver. Telegrams, letters and 'phone calls by the hundred acclaim the first installment of the \$500 Television Course which appeared in PHOTOFACT Folder Set No. 38. If you haven't started the Course (which is running in current PHOTOFACT Folder issues) — be sure to get PHOTOFACT Sets No. 38, 39 and 40 today! Stay ahead of the game with PHOTOFACT!

**Don't Miss a Single Installment!**

## Dial Cord Stringing Guide

The book that shows you the one *right* way to string a dial cord. Here, for the first time, in one handy pocket-sized book, are all available dial cord diagrams covering over 2300 receivers, 1938 through 1946. Makes dial cord restringing quick and simple. Pays for itself in time saved on a single dial cord repair job. A "must" for every service bench and tool kit. Order today! **ONLY \$1.00**



## BOOST YOUR EARNING POWER!

Mail This Order Form  
to HOWARD W. SAMS & CO., INC.  
2924 E. Washington St., Indianapolis 7, Indiana

My (check) (money order) for \$.....enclosed.

- Send Photofact Sets 38, 39, 40. (\$1.50 per Set).
- Send Photofact Volume 4 (including Sets Nos. 31 through 40) in DeLuxe Binder, 18.39.
- Vol. 3.  Vol. 2.  Vol. 1 (\$18.39 each).
- Automatic Record Changer Manual, \$4.95.
- Tube Placement Guide, \$1.25.
- Dial Cord Stringing Guide, \$1.00.
- Send FREE Photofact Cumulative Index.

Name \_\_\_\_\_

Address \_\_\_\_\_

City \_\_\_\_\_ State \_\_\_\_\_

**HOWARD W. SAMS & CO., INC.**  
INDIANAPOLIS 7, INDIANA

Export—Ad. Auriema—89 Broad St., New York 4, N. Y.—U. S. of America  
Canada—A. C. Simmons & Sons, 301 King St., East—Toronto, Ontario

**PHOTOFACT SERVICE**

"The Service that pays for itself over and over again!"

# Centralab Announces an

➔ See how **EASILY** and **QUICKLY** "Adashaft"\* Radiohms can be assembled!

No WIGGLE, no wobble, no slip when you use Centralab's "Adashaft" Radiohm. Just insert shaft pilot in hole provided in control stub shaft, and slip "C" washer into place. Quick as a wink, control and shaft become an integral unit, ready for smooth, trouble-free operation. Notice the wide selection of shaft types which Centralab offers you — for every kind of set from large radio-phonograph combinations to small automobile receivers. Shafts are rugged—built to withstand hard usage, yet easy to cut to lengths required.

*\*Trademark registered*

BEFORE ASSEMBLY

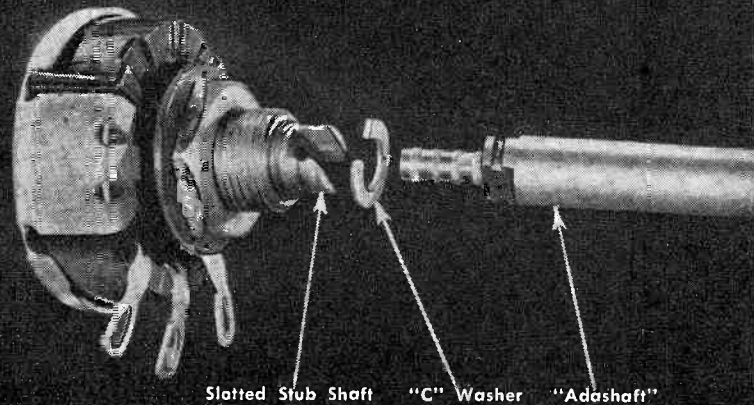

AFTER ASSEMBLY

Where line switches are required, use **CRL attachable Switch Covers!**

Available in five types for "R" Radiohms, 4 types for "M" Radiohms, 1 type for "E" Radiohms. Minimum life of 50,000 mechanical and electrical operations. Underwriters approved. Contact carrier is propelled by full-floating, compression type spring, provides easy, positive action. Rated at 5 amp., 125 volts; 1 amp., 250 volts.



# Improved "Adashaft" Radiohm!

SIX TYPES OF SHAFTS GIVE YOU WIDE VARIETY!



K-185 3" Fluted "Adashaft" (supplied standard)



K-176 1 $\frac{1}{16}$ " Split "Adashaft"



K-177 3 $\frac{7}{8}$ " Split Knurl "Adashaft"



K-166 3" Auto Type "Adashaft"



Long Guide Funnel



Short Guide Funnel



K-167 6" Auto Type "Adashaft"



Long Guide Funnel



K-165 10" "Adashaft"  $\frac{1}{32}$ " flat



K-184 Slotted Insulating Coupler



K-161 Coupler Shaft

 See how "Adashaft" Radiohms cut down overhead on service and repairs!

NOW, YOU CAN HAVE a small stock of controls on hand, yet be prepared to handle almost any kind of control replacement problem for your customers! Yes, that's what Centralab "Adashaft" Radiohms give you, and that's why more and more radio service dealers are using them to speed up service and cut down inventory.

Centralab "Adashaft" Radiohms are avail-

ble in all sizes for all Model "M" volume control applications. See for yourself how they can streamline your service operations. Ask your jobber about them, or write direct for further information.

## Centralab

Division of GLOBE-UNION INC., Milwaukee

# SUPER VALUES from MID-AMERICA!

## Stromberg-Carlson DYNATENNA

This famous-make FM antenna has been advertised and sold for many times the low price MID-AMERICA asks! Covers both FM bands. Delivers FM reception at its best. Complete with 60 ft. of 300-ohm twin lead-in. Line is standard approved flat-type, solid dielectric with weather-resisting insulation. Mounts anywhere easily . . . vertically or horizontally to match polarization of trans-

mitting station. Illustrated instructions and all necessary hardware. A screwdriver is only tool needed for assembly. Dynatenna is seamless, heat-treated, all aluminum . . . will withstand severest weather.

**\$4.95**

each  
\$4.45 each  
in lots of 3

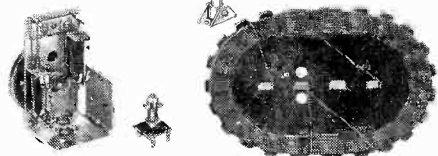

## PERMEABILITY TUNER

Build a really HOT 5 or 6-tube AC-DC superhet receiver! Takes place of old-style gang condenser, of and antenna coils: regular 455 KC intermediate frequency. **MA-2167** Complete with permeability tuned oscillator coil. 4 x 2 1/2 x 2 1/2" diameter dial drum. Complete with diagrams for building 5 and 6 tube sets. Order **MA-2169** Loop Antenna . . . **15c**  
Order **MA-2914** Drilled, punched Chassis . . . **39c**

**\$1.24**

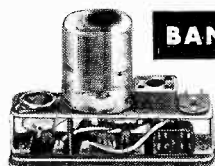

## BANTAM 1-WATTER

BCR-746-A tuning unit used as foundation for Bantam 1-Watter described in Jan. 1948 QST. Makes tiny crystal-controlled CW xmitter. Measures only 3 3/8" long, 2 1/2" high, 1 1/2" wide. Requires only 1 1/2 volts "A", 30 to 90 volts "B". Draws 8 to 15 ma under load. Supplied less crystal, 1S4 tube and plug-in coil MA-907 . . . **24c**

## SPECIAL AUDIO TRANSFORMERS

Exceptionally high-quality universal output transformer for up to 12" speakers. Rated at 12 watts. Matches any single push-pull or parallel tubes to 6-8 ohm voice coil. 12" color-coded leads. 2" high with 2 1/2" mounting centers for installation on chassis or speaker. Complete with instructions for matching tube impedances. **MA-1205 \$1.19**

Hermetically sealed 200 ohm CT to 50,000 ohm grid. Use as microphone transformer, line-to-grid, etc. 2 1/2" x 1 1/2" x 1 1/2". **MA-1262 69c**

Single 3000-ohm to 4-ohm voice coil output for 50L6, 35L6, etc. 1 3/4" high on 2 1/2" mounting centers. **MA-1255 . . . 49c**

## Heavy Duty Noise Filters

Rated on 10 amps, 115-volt AC. Measures only 1" x 1 1/2" square. Install right in amplifiers, receivers and other equipment where line noises must be kept at a minimum. Nationally-known manufacturer. **MA-2164 . . . 79c**

Filter for mobile power supplies. Rated 10 amps, 6-30 VDC. Has additional 2 mfd. 100 VDC condenser. 2" high, 2" square. **MA-2165 . . . 59c**

## SPEAKER SPECIALS

All with Heavy ALNICO 5 Slugs

3 1/2" PM MA-206 2 . . . \$1.39 4x6 Oval PM MA-2187 \$1.39  
5" PM MA-2071 . . . \$1.39 6" PM MA-2189 . . . \$1.95

## ORDER FROM THIS AD!

Quantities are limited, so get your order in now! Minimum order shipped, \$2.50. Send 25% deposit, balance C. O. D. Get on MID-AMERICA's mailing list to receive BIG BARGAIN BULLETINS that list latest, greatest buys in radio parts, electronic equipment. Send orders to Desk RM-68

**MID-AMERICA CO. Inc.**  
2412 S. Michigan Avenue  
Chicago 16, Ill.

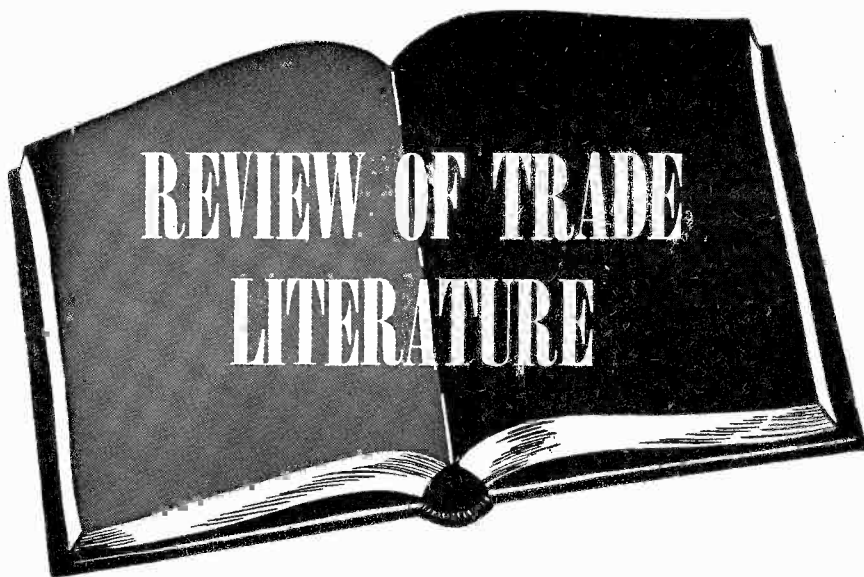

To avoid delay when writing to the manufacturer give issue and page number.

**I**N TIME for this summer's portable radio season, Burgess Battery Company has announced a 1948 Replacement Guide to Battery Operated Radios. This new guide contains up-to-the-minute replacement battery information, listing over 1600 sets made by 100 radio manufacturers, and the correct batteries for each set.

Free copies of this new replacement guide may be had by writing Burgess Battery Company, Dept. KG, Freeport, Illinois.

Terminal Radio Corporation of New York has published a profusely illustrated catalog showing the newest sound equipment for custom-set builders, broadcast stations, recording studios and high fidelity enthusiasts.

Terminal's new Sound Catalog includes the latest amplifiers, tuners, speakers, cabinets, record changers, pickups, phono cartridges, recorders, microphones and essential sound accessories.

The catalog may be obtained free by writing to Terminal Radio Corp., 85 Cortland St., New York 7, N. Y.

A two-color illustrated folder has been published by Altec Lansing Corporation, New York and Hollywood, announcing "a new, basically improved line of general purpose speakers." The folder stresses the claim that the new line is "fundamentally re-engineered, not mere modifications or reworking of present line."

New models are 604B Duplex,

603B Multicell Diacone, 600B Diacone, and a new addition to line, an 8" Diacone. Also illustrated in folder are cabinets available with these speakers.

Highlighted for the first time in Altec Lansing sales literature are frequency response curves for each speaker. Past reason ascribed for not publishing curves: "Published curves on speakers have seemed to reflect more wishful thinking than a true scientific presentation of facts."

Curves now presented by Altec Lansing are declared "accurate reproductions of response frequency characteristic measurements made under outdoor conditions at an elevated height. Ground reflections, and local effects which do not persist over significant areas have been removed from the traces of the automatic recorder."

Folder states: "The methods used in making these measurements are in all cases the preferred type of outdoor automatic measurements recommended by the American Standards Association in their Loudspeaking Testing Bulletin C16.4-1942, and refined by the Altec Lansing research staff."

The folder may be obtained by writing to Altec Lansing Corp., 250 West 57th St., New York 19, N. Y.

Howard W. Sams and Company have just published the first installment of their television course. Based on the resident course given at the Saunders Radio and Electronic School in Boston, it was originally

→ To Page 41

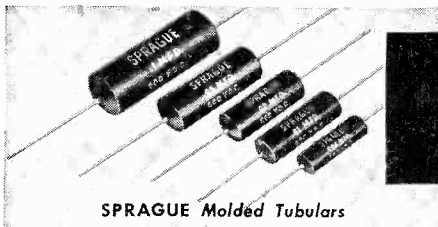

SPRAGUE Molded Tubulars

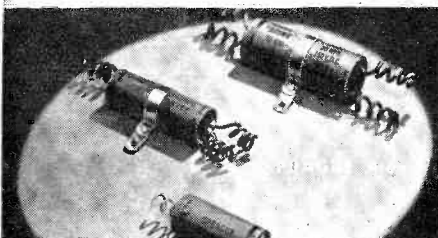

SPRAGUE Koolohm Resistors



SPRAGUE EL Midget C types

# YOUR REPUTATION...

and your customers deserve the best!

# SPRAGUE

These are but a few of the many capacitor and resistor types in the complete SPRAGUE Line. "Specify SPRAGUE" in *all* your repair work. Build a reputation for a quality job while you are building a more profitable business!

## WRITE FOR THE COMPLETE CATALOG

SPRAGUE PRODUCTS COMPANY, North Adams, Mass.

JOBGING AND DISTRIBUTING ORGANIZATION FOR THE PRODUCTS OF THE SPRAGUE ELECTRIC COMPANY

## Pueblo Association

→ From Page 27

detailed service invoice; to offer a 30-day service guarantee on all transactions; and not to handle free inspection calls or operate on Saturday afternoon or Sunday.

All members cooperate in presenting radio spots over the Pueblo radio station; three association spots are used daily, each mentioning a specific member. In addition KOA Denver is utilized once a week for a fifteen minute program, during which Pueblo Association members predict the future of radio. Members of the listening public are invited to send in queries regarding the shape of things to come in radio, and they are answered over the half-hour radio forum.

Association members agree at all times to cooperate with each other in supplying names of deadbeats and slow credit payers.

In a well-rounded nutshell, the Pueblo Radio Association is going great guns and expects to continue in this vein for many years. The headquarters is at 54 Vanderstan Avenue, Pueblo, Colorado. ✓ ✓ ✓

## The ONLY POWER SUPPLY that gives these ratings\* without overheating

**Electro**  
ELECTRICAL AND RADIO EQUIPMENT

### MODEL "A"

- \* 6V at 15 amps. in parallel
  - \* 12V at 7½ amps. in series
  - \* 6V at 7½ amps. separately
- 115 volts 60 cycles input

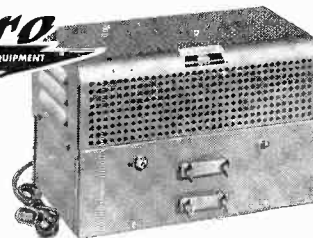

Operates auto radios with solenoid tuning and tone controls — also 12 volt marine and aircraft radios.

Height: 7¾" Length: 11¾"  
Width: 7¾" Ship. wt. 31 lbs.

DC OUTPUT

Oversize transformers, chokes and rectifiers insure against overheating. Large capacity condensers for wide-range voltage regulation. Instantaneous power for solenoid operation. Two separately filtered DC output sources.

Compact. Sturdy. 18-gauge steel construction. Handsome blue Hammerloid finish. Comes completely equipped including 6' rubber cord and plug. Vastly superior and costs no more than batteries for equal service.

Send for complete description of this up-to-the-minute power supply.

### ELECTRO PRODUCTS LABORATORIES

Pioneer Manufacturers of Battery Eliminators

549 West Randolph Street

Chicago 6, Illinois



No reason to put off buying that new test equipment you want and need. Never before in Walter Ashe history have allowances on used factory-built Test Instruments been so generous. So now is the time to trade and save real money. Simply tell us on the coupon what you have to trade. List your preference in new equipment. Back will come our big new "surprise" offer. Don't delay.

**MAIL THIS COUPON TODAY!**

Walter Ashe Announces  
**" BIGGER-THAN-EVER "**  
**"SURPRISE"**  
**TRADE-IN**  
**ALLOWANCES**  
 ON YOUR USED  
**TEST EQUIPMENT**



Use this coupon to get Walter Ashe's "Surprise" Trade-In Allowance on your used factory-built test equipment. RM 6  
 WALTER ASHE RADIO CO.  
 1125 Pine St., St. Louis 1, Missouri

Am interested in the following top condition, slightly used Test Equipment \_\_\_\_\_ (list preference)

I want to trade \_\_\_\_\_ (describe used equipment)

for \_\_\_\_\_ (show make, model of new Test Instrument desired)

Rush my FREE COPY of the big, New 1948 Walter Ashe Catalog.

NAME \_\_\_\_\_

ADDRESS \_\_\_\_\_

CITY \_\_\_\_\_ ZONE \_\_\_\_\_ STATE \_\_\_\_\_

*Walter Ashe*  
**RADIO CO.**  
 "Test Equipment Headquarters"  
 1125 PINE ST. ST. LOUIS 1, MO.  
 PHONE CHEstnut 1125

**OTHER WALTER ASHE STAR ATTRACTIONS:**  
 SMASH VALUES IN RECONDITIONED "GOOD-AS-NEW" TEST EQUIPMENT.  
 ALL THE BIG-NAME BRANDS OF NEW TEST INSTRUMENTS IN STOCK, READY FOR IMMEDIATE DELIVERY.  
 CONVENIENT TIME PAYMENT PLAN.

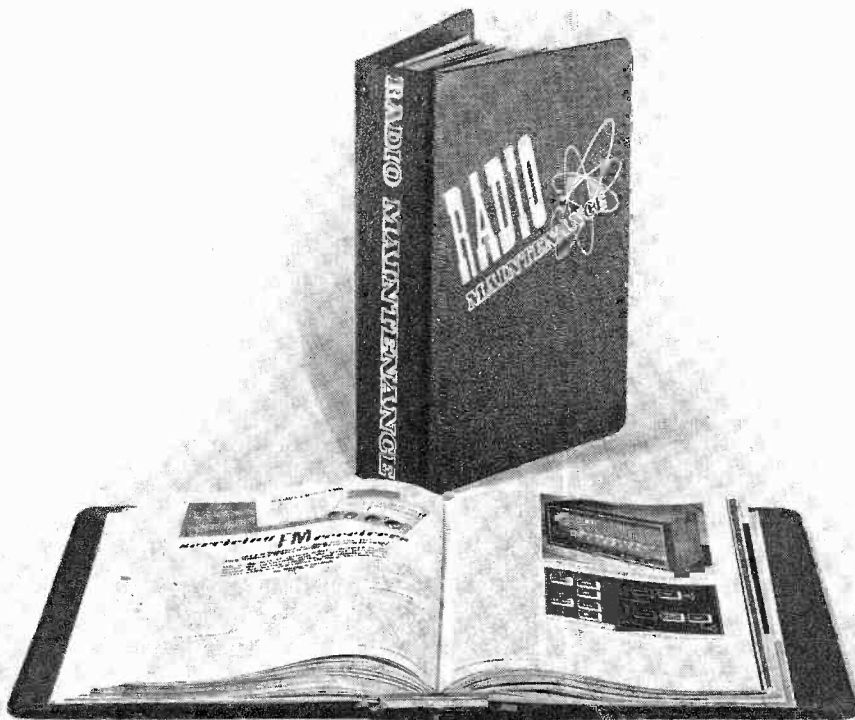

Keep your back numbers of **RADIO MAINTENANCE** in these handsome green and gold binders. Each binder will hold up to 18 copies of the magazines without puncturing holes or mutilating them in any way. They are held securely but are easily removed if desired. With the index printed at the end of each year, your magazines will be a constant reference for . . . a valuable service library. Send for your binders now!

**BINDERS**

**TO PRESERVE YOUR  
 RADIO MAINTENANCE  
 MAGAZINES**

**RADIO MAINTENANCE**  
 460 Bloomfield Avenue  
 Montclair, N. J.

Please send me \_\_\_\_\_ binders at \$3.00 each.

Total amount enclosed \_\_\_\_\_

Name \_\_\_\_\_

Address \_\_\_\_\_

City \_\_\_\_\_ Zone \_\_\_\_\_

State \_\_\_\_\_

## F.M. and You

→ From Page 23

Network." Starting with four stations, about a year ago, it has grown to 41 stations. The locations of these stations extend from South Carolina to Canada. Most of the interconnecting links between stations are radio relays which give reliable high fidelity transmission at much less expense than the elaborate type of cable needed for wide frequency range transmission.

Add all this up and the future is clear. Whether or not f.m. will replace a.m. entirely may be open to question. That f.m. is now rapidly increasing in importance nobody will deny.

Millions of new f.m. sets will be put into use in 1948. That means installation jobs which are new and different and which require the serviceman's skill in new measure. Repair jobs will include a much higher percentage of f.m. tuners and combination receivers. A new understanding of high fidelity by set owners will require higher maintenance standards in audio repair work.

Here are some of the things a serviceman should know to be well prepared for f.m. work.

1. How to choose the proper antenna and transmission line for any given location. How to erect this antenna and adjust it for maximum efficiency.
2. The operation of the special r.f. amplifier and converter circuits used in f.m. receivers.
3. The difference between f.m. i.f. amplifiers and their a.m. cousins.
4. How to adjust and maintain all of the new detector circuits.
5. The nature of high fidelity. Weak points in audio amplifiers and how to please the customer's ear.
6. Alignment requirements which are quite different from those of ordinary a.m. broadcast receivers.
7. What test equipment is necessary and desirable for practical servicing work.

This knowledge can be obtained by attending school, through correspondence courses, by reading books and magazine articles, and by personal experimentation. The time and money expended in equipping yourself and your shop for f.m. servicing will be well repaid. ✓✓✓

# For EXPERT TELEVISION SERVICING...

## Your oscillograph MUST have

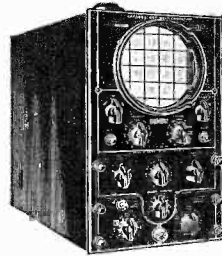

good low-frequency response to align video and r-f amplifiers and video and f-m i-f amplifiers. You NEED an adequate low-frequency response to display correct detector and discriminator curves. Also, you MUST have deflection sensitivity better than 0.02 rms volt/in. to obtain a readable pattern on the cathode-ray tube. The Du Mont Type 208-B Cathode-ray Oscillograph has a sensitivity of 0.01 rms volt/in. and its frequency response is 2 cps to 100 kc.

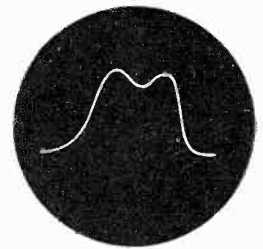

Frequency-response curve of i-f amplifier

**Cat. No. 1146-A, \$270.00**

## For GENERAL trouble-shooting

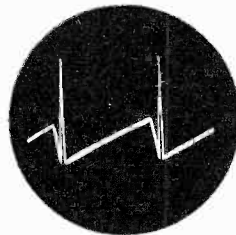

Sawtooth waveform and sync pulse of vertical sawtooth generator

such as checking video amplifiers and observing sync pulses, your oscillograph MUST have a HIGH frequency response of approximately 2 mc (higher response is not necessary) with a deflection sensitivity of 0.1 rms volt/in. to examine the waveform of these signals in the various circuits. The Du Mont Type 224-A has a sensitivity of 0.1 rms volt/in. and a frequency response to 2 mc. The Type 224-A also employs continuous sweep, which is entirely satisfactory for servicing applications.

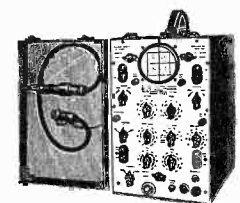

**Cat. No. 1191-A, \$290.00**

## ... and to CHECK Signal level

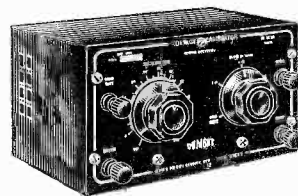

at specific points, as designated by the television set manufacturer, the Du Mont Type 264-A Voltage Calibrator is ideal for measuring the voltage amplitude of ANY PART of a complex signal displayed on your oscillograph.

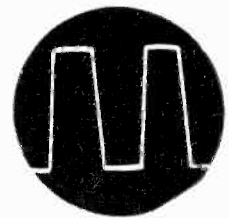

Square-wave output for measuring signal amplitude

**Cat. No. 1240-A, \$39.50**

- These three instruments constitute the "MUSTS" of Expert Television Servicing. Descriptive literature sent on request.

# DU MONT

**ALLEN B. DU MONT  
LABORATORIES, Inc.**  
Passaic • New Jersey

Cable Address: Albeedu, Passaic, N. J., U. S. A.

# No More Guesswork



## OHMITE Little Devil

### COMPOSITION RESISTORS

You never have to guess about the resistance and wattage of any Little Devil resistor. Every unit is not only color-coded but individually marked for quick, positive identification. Millions used in critical war equipment. Standard RMA values from 10 ohms to 22 megohms, in ½, 1, and 2-watt sizes. Tol. ± 10%. Also ± 5% in ½ and 1-watt sizes.

Available Only Through OHMITE Distributors

Ohmite Manufacturing Co.  
4913 Flournoy St., Chicago 44, Ill.

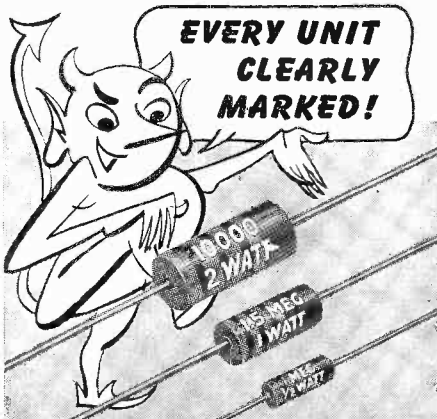

## Super Service

→ From Page 17

efficient appearance of the place. Bench after bench of busy technicians, an amazing array of technical looking equipment, and hundreds of radios being processed make a business-like impression.

### The Stockroom

Three men are kept busy in the stockroom doling out parts to the many servicemen, ordering parts and equipment, wrapping and shipping and generally keeping the huge stock up-to-date. All standard replacement parts for radios and record changers are stocked, as well as many special parts. Bill Send is in charge of the stockroom, and Bill says that it requires constant vigilance to keep track of the countless springs, gears, pins and other parts that go into the repair of a dozen different record changers, as well as innumerable parts for portables, auto radios, f.m. sets, and ordinary home radios.

### The Recall Department

Only a small number of the thousands of sets that pass through Brownie's are returned for unsatisfactory performance, and usually

wear and tear, rather than bad workmanship, is the reason Brownie Radio gives a three (3) month unconditional guarantee on all repaired sets, regardless of what work was done on them. If only a tube was replaced, and something else goes wrong with the set within the 90 days, it is repaired at no charge whatsoever, no matter what went wrong. This feature is one of the reasons why Brownie retains its customers and friends. No matter how small a repair job is, the set is checked over completely for damaged or suspicious-looking parts, adjustments are made, and the set checked for overall performance. Barring accidents, the serviceman is fairly certain that when that set goes out, it will stay out. No one can predict a tube burn-out, especially in a.c.-d.c. models, but the guarantee applies just the same. Radio batteries, of course, do not come under the guarantee.

In charge of the entire service department is Robert Simler, the shop foreman. Simler worked in every department in the business, before becoming foreman, and knows the routine from all angles. An expert technician himself, he keeps the organization running smoothly and efficiently.

Yes, radio servicing is really big business at Brownie Radio Service, Inc. ✓ ✓ ✓

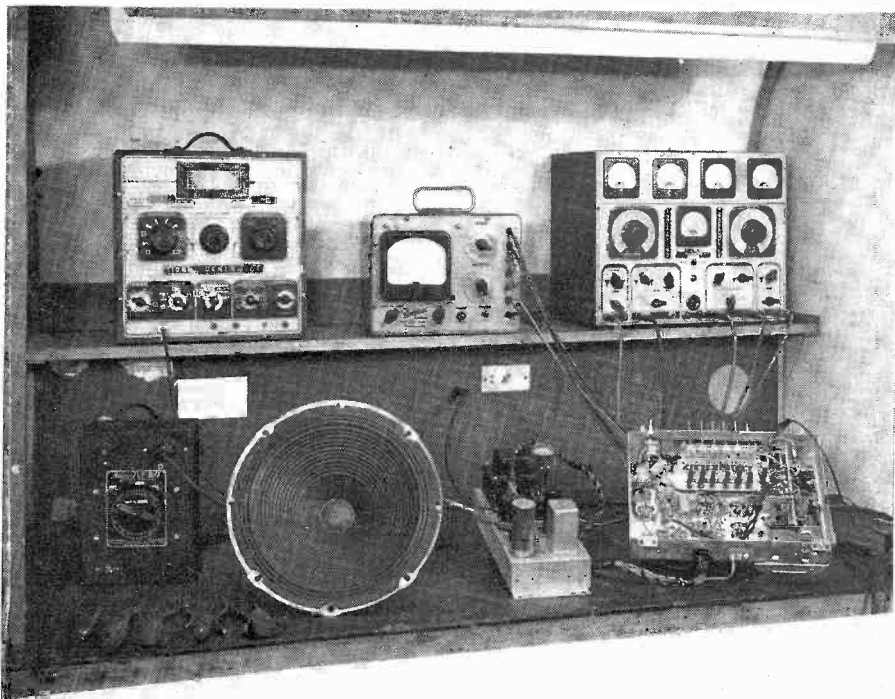

FIG. 5 THE INTERIOR OF ONE OF THE TROUBLE-SHOOTING AND REPAIR BENCHES. THESE BENCHES ARE CLOSED IN ON THE REAR, TOP, AND SIDES TO REDUCE NOISE AND ARE LIGHTED BY TWO FLUORESCENT TUBES.



# Electronically Speaking

A New York "Town Meeting for Electronic Technicians" was authorized by the RMA during the U.S.-Canadian RMA conference at Toronto. The meeting was authorized on recommendation of Chairman J. J. Kahn of the RMA Parts Division. Although the date has not yet been fixed, it is expected to be some time this summer or early fall. According to an RMA release, the New York "Town Meeting" was given priority because of RMA's recent action opposing a proposal to license radio servicemen in New York City and requests of a New York radio servicemen's organization that a clinic be held there as soon as possible. Emphasis will be placed on training for television set servicing at the New York meeting.

A nation-wide series of television antenna forums has been announced by the J. F. D. Manufacturing Company. According to the company, the purpose of the symposiums is to assist all servicemen with specific antenna installation problems relating to location and selection of arrays. The first forum is scheduled to be held at the Hotel Sheraton in Newark, N. J. Other meetings will be held in areas throughout the country where clarification and information on antenna installation problems is needed. The dates and locations of future meetings will be announced shortly.

National Radio Week will be November 14 through 20. According to the RMA, another "Voice of Democracy" contest for high school students will be held.

A servicing meeting discussing Television, F.M. and Public Address equipment is being sponsored by John F. Rider Publisher, Inc. It is scheduled for May 20th at the Man-

→ To Page 41

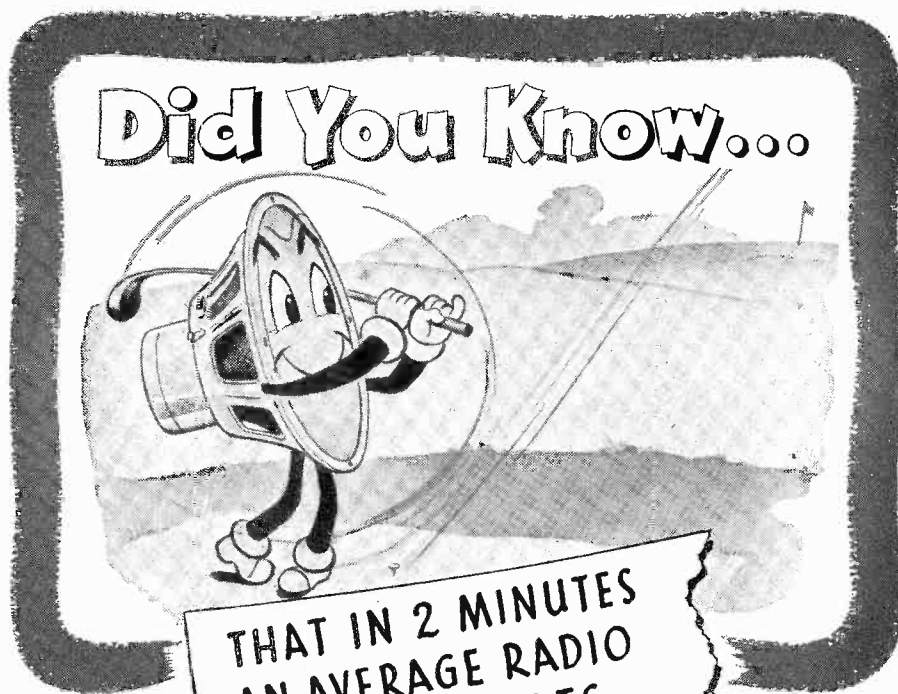

## Did You Know...

THAT IN 2 MINUTES  
AN AVERAGE RADIO  
SPEAKER EXERTS  
ENOUGH ENERGY TO  
DRIVE A GOLF BALL  
OVER 575 YARDS?

**W**e know it's impossible for a speaker to swing a golf club, but *it is true* that in just 2 minutes time an average loudspeaker does exert enough energy to drive a golf ball over 575 yards! This means that although OPERADIO builds speakers with the skill and care of a watchmaker . . . these speakers are sturdily constructed to stand up under heavy, continuous use. OPERADIO speakers are delicately balanced to authentically reproduce the sweetest high notes of a piccolo, yet, carry the tremendous power of a full orchestra crescendo.

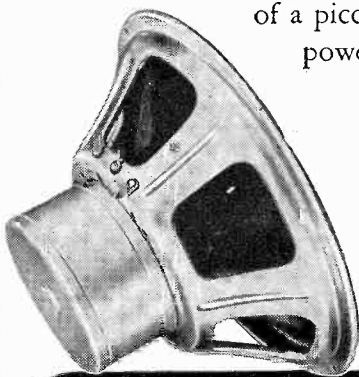

**ASK FOR OPERADIO SPEAKERS —  
A FULL LINE OF OUTSTANDING  
SPEAKERS FOR EVERY PURPOSE!**

## oPERADIo

### RADIO REPLACEMENT and PUBLIC ADDRESS SPEAKERS

**OPERADIO MFG. COMPANY • St. Charles, Illinois**

# Free



**Concord**  
**RADIO CATALOG**  
23 pgs. Radio & Television Sets - 62 pgs. Radio Parts - 18 pgs. Sound Amplifiers & Accessories - 23 pgs. Ham Gear - 9 pgs. Electronic Test Equipment

**160 VALUE-PACKED PAGES**

Write for FREE copy of this great, new Concord Catalog—a vast, complete selection of everything in Radio, Television and Test Equipment. Thousands of items... new, latest 1948 prices. See new LOWER prices on finest-quality RADIO SETS, PHONO-RADIOS, RECORD CHANGERS, RECORD PLAYERS, RECORDERS—wire and disc, PORTABLES, AMPLIFIERS, COMPLETE SOUND SYSTEMS, TESTERS. Complete latest listings of all well-known, standard, dependable lines of radio parts and equipment. 4,212,014 SATISFIED CUSTOMERS CANNOT BE WRONG! For more than a quarter century at CONCORD the customer has been the Most Important Person in the world. This established reputation for Customer Satisfaction is the reason Radio Men (the Experts Who Know) keep coming back to CONCORD for every radio and electronic need. At CONCORD, YOU MUST BE COMPLETELY SATISFIED or your money will be cheerfully refunded. Write for Catalog Now—Please address Dept. 186.

**CONCORD RADIO CORP.**  
CHICAGO 7      ATLANTA 3  
901 W. Jackson Boulevard      265 Peachtree Street  
Downtown Chicago Branch: 229 W. Madison Street  
LAFAYETTE RADIO CORP.



Free illustrated booklet tells the "Inside Story" of an amazing new servicing method. It also contains valuable "hints and kinks" for every radio man. Just send your name, address, and the words—"Inside Story"—on a post card and we will mail your copy at once, without cost or obligation. Do it now before you forget!



**FEILER ENGINEERING CO.**  
Dept. 5H8 945 George St.  
Chicago 14, Ill.

## Distortion

→ From Page 26

about 2 to 1. In the better receivers, however, the output is almost constant. A simple method of checking this variation and the general stability of the oscillator is by connecting the r-f probe of a v.t.v.m. to the oscillator grid resistor (Fig. 8) and observing the output voltage while rotating the tuning condenser through the tuning range. The oscillator frequency will be lowered when the r-f probe is attached to the grid resistor and therefore it will become necessary to retune the oscillator slightly, if it is desired to observe its output at any specific frequency setting.

The stability of an oscillator is generally improved with a high value of grid resistor, but should this value become too great, oscillation may become intermittent or cease entirely. The wiring and other components associated with the oscillator circuit must be rigid and care should be exercised to avoid disarranging any of these from their original position. This is especially important in the case of high frequency oscillators. Displacement of any of these components may result in absorption of some of the oscillator output at certain frequencies due to the proximity of other circuits which may resonate at these frequencies.

Distortion sometimes originates in the mixer stage. A trouble sometimes encountered is that of image effects resulting from oscillator harmonics beating with the incoming signal and producing an interfering i-f signal.

Reducing the a.v.c voltage that is applied to the mixer stage will usually remedy this trouble. It must be remembered, however, that the a.v.c. time constant should not be upset in the process of installing a voltage divider.

The oscillator voltage which is induced into the control grid circuit of the mixer tube should not become equal to the grid bias voltage of the mixer. If this condition should exist when the grid bias is normal, the oscillator output may be reduced by reducing the oscillator plate voltage or by installing a lower value of grid resistor.

There are other factors not associated with the chassis proper which may contribute to distorted reception, such as incorrect phasing of multiple speakers, microphonic action and acoustic feedback, and even the cabinet itself may contribute its share of trouble. Buzzing and rattling noises are often caused by sympathetic vibrations of loose cabinet paneling or loose grill work located in front of the speaker.

## Speaker Phasing

The phasing of twin or multiple speaker voice-coils may be checked by connecting a source of low d-c potential such as a 1½ volt dry cell in series with the voice coil circuit (Fig. 9) and placing the fingers lightly on the speaker cones as the circuit is closed. At the instant contact is made, the cones will make a decided movement in either the inward or outward direction. When properly phased they will all move in the same direction. The direc-

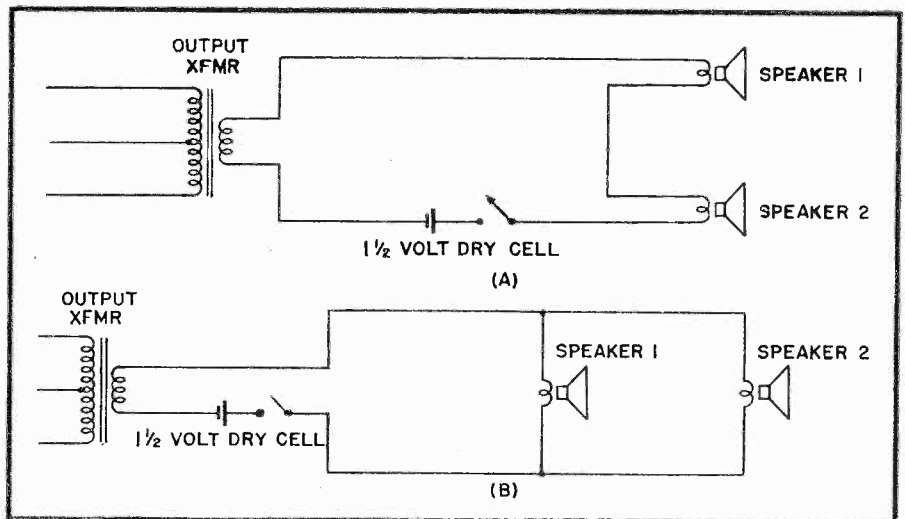

FIG. 9 THE METHOD USED TO CHECK SPEAKER PHASING. A IS FOR SERIES SPEAKERS AND B IS FOR PARALLEL SPEAKERS.

tion of movement of any individual speaker cone is changed by merely reversing its voice coil leads.

Sound vibrations which are transmitted from the speaker to the chassis will sometimes cause certain components on the chassis, such as the tuning condensers or oscillator coil, etc., to vibrate in unison with the speaker cone, resulting in sustained oscillations, which usually introduce a roaring or howling sound into the output. The installation of rubber cushions under the chassis, if these are not already employed, will often remedy this trouble. The installation of rubber washers between the speaker and the cabinet will also often help to effect a cure. In some cases a tube with microphonic qualities will be the chief source of trouble. In such cases it is only necessary to replace the tube. It is suggested that if a tube cannot be found that will be insensitive to the vibrations, that several layers of friction tape be wound around the base of the tube so as to dampen out the induced vibrations.

A torn or otherwise damaged speaker cone will usually produce "rattling" and "buzzing" sounds. Should the speaker voice coil be out of alignment so that the voice coil rubs against the pole pieces, a rasping "tinny" sound will result which will be especially pronounced at low volume, and at the lower audio frequencies.

The possibilities of distortion are many and varied, but an attempt has been made to give the reader a basic outline from which to start, along with several service hints on actual cases. ✓ ✓ ✓

## FREE CATALOG

Simply send your name and address and receive free our new big 1948 catalog. Hundreds of radio parts values.

AMERICAN SALES CO.  
1811 W. 47TH ST. CHICAGO, ILL.

## JUST OPENED!

Federated's New Branch  
ALLENTOWN, PA.

With completely stocked warehouse and show-rooms, featuring all standard brands in Radio, Electronic Parts, & Equipment. IF YOU'RE AROUND—DROP IN AND SAY HELLO!

Federated Purchaser Inc.

1115 Hamilton St., Allentown, Penna.  
PHONE: Allentown 3-7441

# Tailor-made

## for WIRE RECORDER- RADIO combinations



MODEL  
**78**

with push-button  
control

## Webster-Chicago WIRE RECORDER

is a top quality, precision unit designed for installation in radio console or for use in semi-portable applications with radio or high fidelity amplifier. Model 78 provides all combinations... recording from radio or microphone; playback through headphones, radio or external amplifier, with simple push-button control of electrical circuits. A sensitive meter provides accurate recording level indication and the wire transport mechanism is positive acting and foolproof.

**Easy to install...** Model 78 is easy to install, and makes an ideal combination. Contained in an attractive metal case which mounts as a complete unit, Model 78 is furnished complete with microphone, one spool of wire and all necessary plugs, cords and instructions for neat installation.

■ The radio-listening public is demanding auxiliary equipment for more complete enjoyment of their radio programs, record music and home entertainment.

■ DEMONSTRATE and install Webster-Chicago Model 78 Wire Recorder.

■ Ask your Webster-Chicago Distributor



## WEBSTER-CHICAGO

famous, too, for Webster-Chicago Record Changers and  
Magic Nylon Phonograph Needles

5610 W. BLOOMINGDALE AVE. • CHICAGO 39, ILL.



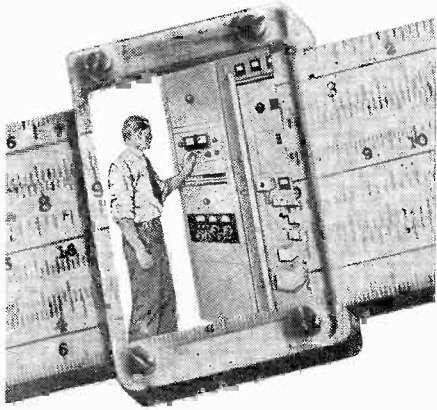

## Here's How You Can Figure on a BETTER JOB in RADIO-ELECTRONICS, Broadcasting, Television, Servicing, Manufacturing.

You can't plan your future on a slide rule. But you can take a measurement of your own capabilities.

Look at the successful serviceman. You'll find that he's the fellow who looked and planned ahead. Today, you have the same opportunity—at a time when radio's technical progress has gone beyond the supply of technical Manpower. Never before have so many men like you had the opportunity to step ahead into better-paying jobs . . . jobs that offer real interest and security in any one of the many expanding fields that urgently need competently trained men.

You can't say, "I don't need more training." Every ambitious radio technician needs more training. No matter what your experience, you must fortify yourself with up-to-date technical knowledge to qualify for the better jobs and to stave off the new competition that war-time activity has brought into the field.

CREI has a course of training for you. You will find our proved type of training practical and thorough. Whether your future lies in broadcasting, television, servicing, manufacturing or any branch of communications, you will find that you can "go all the way with CREI" from introductory, basic principles to advanced training, and on to specialized fields of radio-electronics.

### MAIL COUPON FOR FREE BOOK

If you want a more secure future and want to make more money, let us prove to you we have the training you need. To help us intelligently answer your inquiry—please state briefly your background of experience, education and present position.



**Veterans! CREI Is "G. I." Approved**

Capitol Radio Engineering Institute  
16th and PARK RD., N.W., DEPT. RT-6  
WASHINGTON 10, D. C.

Mail me your 24-page booklet "CREI Training for Your Better Job in Radio Electronics."

Check field of greatest interest:

- PRACTICAL RADIO-ELECTRONICS
- PRACTICAL TELEVISION
- BROADCASTING
- RECEIVER SERVICING
- AERONAUTICAL RADIO ENGINEERING
- INDUSTRIAL ELECTRONICS

Name .....

Street .....

City ..... Zone ..... State .....

I am entitled to training under G. I. Bill



by John T. Frye

**I**N GENERAL, customers are poor judges of a radio repairman's ability. They do not have the technical background to distinguish between a simple repair and one requiring exceptional knowledge and technical skill; and they are quite likely to allow their opinions to be colored by bluff, showmanship, or personality traits on the part of the radio mechanic.

Other servicemen, though, such as yourself, are not so easily fooled. As soon as you flip a chassis upside down on your bench, you are able to form a pretty accurate opinion of the ability of the last man who worked on it. A dozen little things tell the story to your practiced eye. That is why, from a purely technical point of view, the best serviceman is he who might well be called the "serviceman's serviceman."

The other afternoon a gang of us "solder-slingers" were talking about what constituted a real "serviceman's serviceman." Here is what we decided:

He must have a very sound grounding in radio theory. It does not matter where he got this, but he simply must know what every single condenser, resistor, coil, and tube-element *does* in any standard radio circuit. Not only must his knowledge be deep, but it must be broad as well. He should be able to puzzle out the functioning of any electronic circuit, no matter whether it be an electric-eye bean-sorter or an electronic organ. Finally, his knowledge must be up-to-date. He should be thoroughly familiar with the basic TV and FM theories and with the circuits required to accomplish the special needs of these services. It may be possible that his location makes it impossible for him to obtain

first-hand experience in these mediums, but that is no excuse—not in these days of up-to-the-minute magazine articles—for his being a single step behind his fellow workers in his knowledge of theory.

Our good serviceman is experienced, too. He is as well acquainted with the usual weaknesses of popular sets as he is with the personality traits of his friends. He is able to diagnose correctly a high percentage of radio defects simply by listening to the sets play. The steps he takes to "corner" a particular trouble are few, direct, and decisive.

He is a good mechanic. His tools are kept in excellent shape, and he is an expert with the soldering iron. Every joint he makes is mechanically rigid before solder is applied; and the joint itself is neat, smooth, rosin-free, and with no excess of solder. What is more, he is careful that he does not burn insulation, melt the wax out of condensers, or do other damage by the careless use of his soldering iron.

Our radio mechanic leaves no parts to drop down and dangle by their leads when the chassis is pulled from the cabinet. Every part is firmly anchored in the best possible place. You never catch him placing a dry-electrolytic filter condenser directly alongside a heat-radiating resistor. He knows that to do this is to cut the life of the condenser in half. He is careful, too, about the dressing of leads. If he has to disturb wires, he places them back exactly as they were, after he is through. What is more, he replaces *all* of the hardware he is forced to remove during his service work. He is not one of those slovenly workmen who replace only one of the two nuts intended to hold an i-f can in place or who fasten a

circuits and values.

While leading distributors throughout the country handle Roger Television products, information and prices may be had by writing to Roger Television, Inc., 366 Madison Ave., New York 17, N. Y.

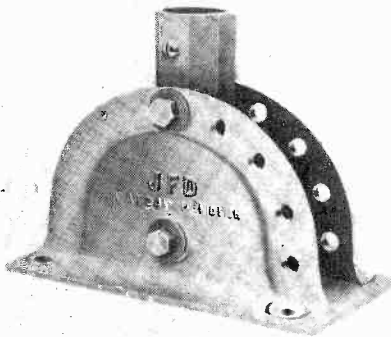

### VERSATILE F.M. AND TV. BRACKET

The J.F.D. Manufacturing Co. has announced an addition to their F.M. and Television Antenna Accessories line.

The new unit—called the "Multi-Position" bracket—solves a wide range of F.M. and Television antenna installation problems, and cuts installation time to a minimum. Its unique design permits swift mounting of antennas, with masts up to 1 3/8" o.d., anywhere—on perpendicular walls, on window sills or on peak, gabled or flat roofs—for maximum reception efficiency. These are only a few of the unlimited adaptabilities of this versatile bracket. Of exceptionally rugged design, the "Multi-Position" bracket strongly resists wear and damage from wind, rain, or ice storms.

The JFD "Multi-Position" bracket is shipped completely assembled. For further information, write to the J.F.D. Manufacturing Co., Inc., 4117 Fort Hamilton Parkway, Brooklyn 19, N. Y., requesting Booklet No. 248S.

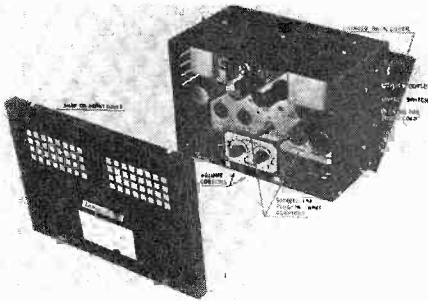

### AMPLIFIER

Plug-In channel adaptors make the new Langevin Type 122 eight watt amplifier an audio unit with many applications. Three extra sockets are provided in each of the two input channels of the Type 122 so that various combinations of PLUG-IN equalizers, transformers, voice filters, and vacuum tubes can be used.

Electrically, the new Langevin Type 122 is a low noise level, low distortion unit with wide range frequency response (eight watts with less than 3% total harmonic distortion from 50 to 15,000 cycles).

Extremely versatile, the new unit answers the need for a small high quality amplifier. For further information write to the Langevin Manufacturing Corporation, 37 West 65th St., New York 23, N. Y.

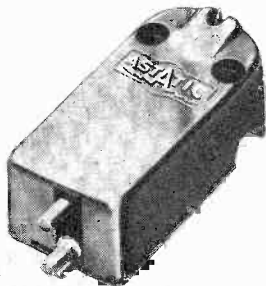

### MAGNETIC PICKUP

A revolutionary new, magnetic type pickup cartridge has been announced by The Astatic Corporation, Conneaut, Ohio. Reversing traditional principles employed in the manufacture of this type of reproducer, the new Astatic "Magneto-Induction Pickup Cartridge" eliminates for the first time the need for delicately spaced, troublesome "air gaps", according to a company spokesman.

Heretofore, presence of "air gaps" and their tendency to collect lint and dust has caused gradually diminishing quality of reproduction in magnetic pickups, defeating certain basic advantages of this type unit, it was stated. The new development offers every inherent advantage, plus an amazing ability to retain original fidelity of reproduction, thanks to elimination of the "air gaps", this leading manufacturer of microphones, pickups and accessory equipment claims.

The radically new cartridge is already available in two models: Model MI-1 with standard housing, and Model MI-2 with Mu-metal housing, which provides increased shielding effect for maximum reduction of hum.

*Built for Service*



**Servicemen's choice!**  
in . . .



• Every year is an election year for Cunninghams in Colorado. People vote for Cunninghams because Cunningham tubes are "built for service." Their top performance and long life make them the outstanding renewal tubes. That's why you should vote to use Cunninghams in your work.

See your  
CUNNINGHAM DISTRIBUTOR

L. B. WALKER RADIO CO. . Pueblo  
L. B. WALKER RADIO CO. . Denver

**Cunningham Tubes**

A product of  
RADIO CORPORATION OF AMERICA  
Harrison, N. J.

## Permoflux SPEAKERS

### YOUR JOBBER CAN SUPPLY YOU!

Permoflux quality and dependability—the same as supplied to the major set manufacturers—is your assurance of complete customer satisfaction. You'll find Permoflux Speakers easy to install and readily available in both PM and Electrodynamic types. You'll find too, that it pays to give your customers "tops in tone" with a Permoflux Replacement Speaker.

TWO COMPLETE  
FACILITIES TO SERVE YOU

PERMOFLUX

WRITE FOR  
FREE BULLETIN

PIONEER MANUFACTURERS OF PERMANENT MAGNET DYNAMIC TRANSDUCERS

**PERMOFLUX CORPORATION**

4900 WEST GRAND AVE., CHICAGO 39, ILLINOIS  
236 SOUTH VERDUGO ROAD, GLENDALE 5, CALIFORNIA

# KEEP POSTED ON ELECTRON TUBES

Use this convenient coupon for obtaining the RCA tube reference data you need.

RCA, Commercial Engineering,  
Section FW-59 Harrison, N. J.

Send me the RCA publications checked below. I am enclosing \$..... to cover cost of the books for which there is a charge.

Name \_\_\_\_\_

Address \_\_\_\_\_

City \_\_\_\_\_ Zone \_\_\_\_\_ State \_\_\_\_\_

- Quick-Reference Chart, Miniature Tubes (Free). [A]
- HB-3 Tube Handbook (\$10.00)\*. [B]
- RC-15 Receiving Tube Manual (35 cents). [C]
- Receiving Tubes for AM, FM, and Television Broadcast (10 cents). [D]
- Radiotron Designers Handbook (\$1.25). [E]
- Quick Selection Guide, Non-Receiving Types (Free). [F]
- Power and Gas Tubes for Radio and Industry (10 cents). [G]
- Phototubes, Cathode-Ray and Special Types (10 cents). [H]
- RCA Preferred Types List (Free). [I]
- Headliners for Hams (Free). [J]

\*Price applies to U. S. and possessions only.



TUBE DEPARTMENT

**RADIO CORPORATION of AMERICA**  
HARRISON, N. J.

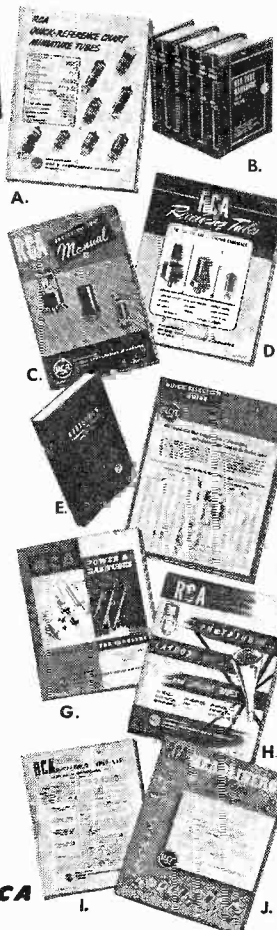

# TIME SAVERS

by H. Leeper

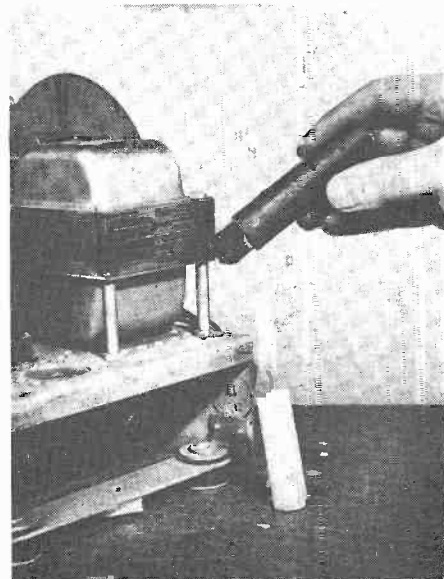

## TRANSFORMER VIBRATION

Ferrule cement such as used to cement tips to fishing rods may often be used to eliminate transformer lamination hum.

This cement is easily carried in stick form and may be applied by use of a candle to heat the laminations and the cement.

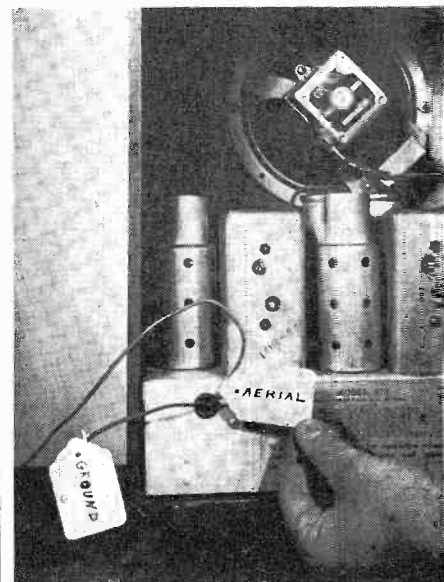

## AERIAL AND GROUND WIRES

Many receivers have two unmarked wires brought out through the rear of the chassis for aerial and ground connections. Customers will often disconnect these wires when moving furniture or cleaning and then reconnect improperly. This leads to an unprofitable call if such occurrence takes place shortly after repairs have been made on the set.

Tagging the leads with ordinary price tags will eliminate the possibility of such trouble.

# REVOLUTIONARY

## THE NEW *Astatic* Magneto-Induction PICKUP

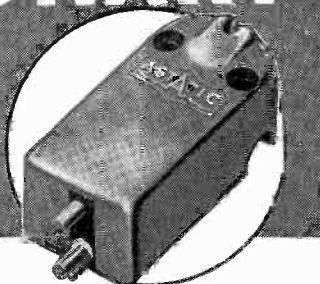

● Yes, this is it! A radically new pickup cartridge that opens broad new vistas of listening pleasure.

The Astatic Magneto-Induction Pickup represents the first clean break with traditional principles employed in the manufacture of magnetic type reproducers. Discarded now is the need for delicately spaced "air gaps," which collect lint and dust, become a prime source of trouble in other type magnetic pickups. Their elimination in the Magneto-Induction cartridge is a newly opened door to peak fidelity of reproduction that is stable and trouble-free, even under the most consistent service or adverse climatic conditions.

**MODEL MI-1**      **MODEL MI-2**  
**Standard Housing**      **Mumetal Housing\***

\*Provides increased shielding effect for maximum reduction of hum.

Also Two Equalizer-Amplifier Models

**NOW AVAILABLE**

### Here are the OUTSTANDING FEATURES

1. No "Air Gaps."
2. No necessity for delicate handling.
3. No costly armature balancing problems.
4. Longer-lived performance without distortion or change.
5. Transcription quality reproduction.
6. Velocity response flat to 12,000 cycles.
7. Output is 100 millivolts, approximately 20 db. greater than most light-weight magnetic pickups.
8. Needle pressure, 1 oz.
9. Impedance, 7,500 ohms at 1,000 c.p.s.—110,000 ohms at 10,000 c.p.s.
10. Interchangeability: Can be employed with most standard pickup and transcription arms.



Manufactured under  
Massa Laboratories License



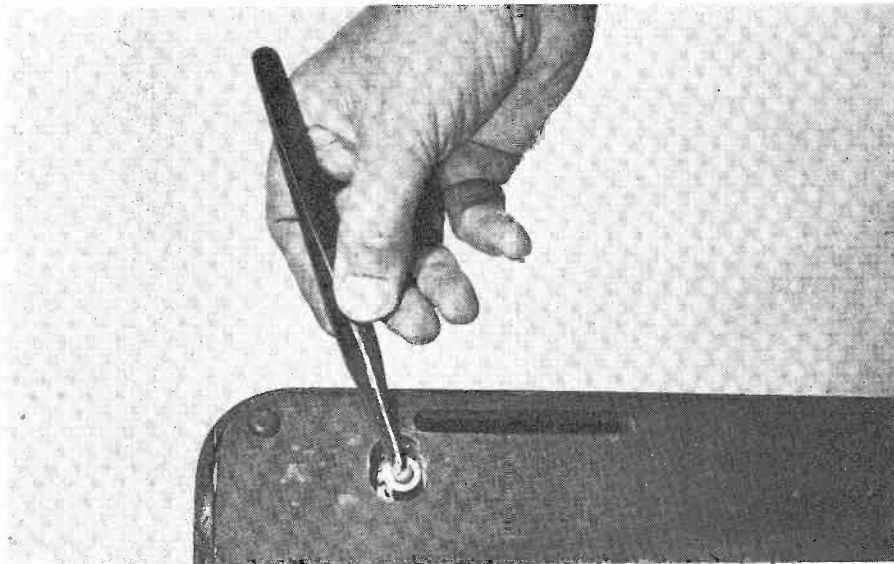

### TWEEZERS SAVE TIME

A pair of tweezers of the type shown will be found a valuable tool for the repair kit. Chassis screws which stick after the threads are disengaged may be gripped and removed with tweezers when other tools such as long nosed pliers will not hold. Many other uses for such a tool will be found around a radio chassis when making repairs.



### HOLDING TORCH

A small alcohol torch is often required to solder wires to the radio chassis or where considerable heat is necessary.

Such torches are light in weight and are difficult to keep in an upright position, particularly where the torch must point at an angle. The use of a sealing compound of the type used by electricians which is of a plastic nature, will solve this problem. This compound while non-hardening, is sufficiently firm to hold the torch in the desired position and is easily removed after using. It may be used repeatedly.

## RECONE — FOR FINER TONE

Send your speakers to A. G. for the original 48 hour RECONING SERVICE

- Parts in stock for *any* speaker
- Audio test at full power rating
- Reasonable prices
- Guaranteed workmanship

Write for price schedule—see how you can profit by tying-in with this new, fast reconing service.

**A. G. RADIO PARTS CO.**

3525 N. 17th St.

Philadelphia 40, Pa.

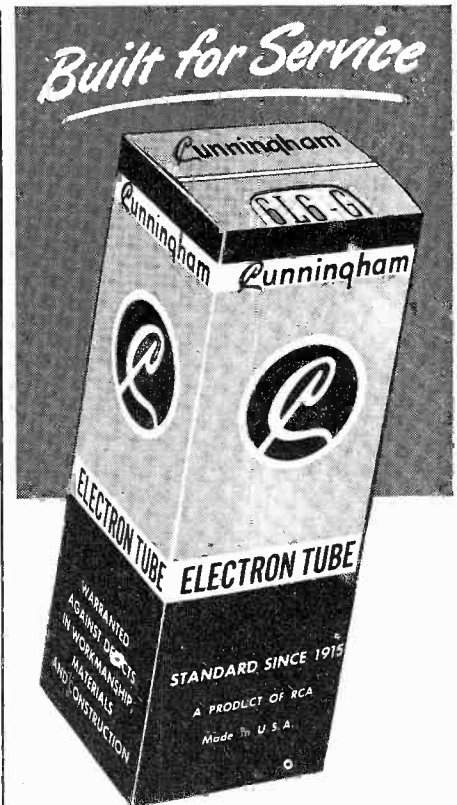

**Servicemen's choice!**

in ...



• For 32 years Cunninghams have enjoyed long terms of service in the Nation's Capital. That's because Cunningham tubes are "built for service" —give outstanding performance wherever they're used. Make Cunningham tubes *your* choice and you'll lead where there's need for top service.

See your  
**CUNNINGHAM DISTRIBUTOR**  
**CAPITOL RADIO WHOLESALERS**  
**Washington**



# 12 BOOKS IN 1 IN THE RADIO DATA BOOK

**THE ONLY RADIO HANDBOOK OF ITS KIND! . . . 1148 PAGES . . . 12 SECTIONS, EACH A COMPLETE COVERAGE OF ONE RADIO SUBJECT.**

**TOGETHER, THE 12 SECTIONS FORM THE MOST COMPLETE, EASY TO READ HANDBOOK MONEY CAN BUY!**

Plan every operation in radio and electronics with the *Radio Data Book*. This new radio bible will be your life-long tool . . . you will use it every day, on the board, at the bench, in the field! Use it for engineering, construction, troubleshooting and testing. The RADIO DATA BOOK will be your invaluable aid in design, experiment and in layout. It will help make your production better, faster and easier. In any and every operation in radio and electronics, you will use the RADIO DATA BOOK!

The RADIO DATA BOOK is a work of complete authority, prepared by engineers with many years of practical experience. They have been assisted by the Boland & Boyce staff of editors skilled in preparing electronics manuals for the U. S. Signal Corps for many years. These men have worked for several years gathering material for this book . . . all the knowledge of radio principles and operation . . . all the statistics . . . all the newest developments in electronics . . . every possible angle and detail. Eighteen months were spent digesting this material into the most concise, the clearest, and the most readable form. The result is this invaluable manual . . . The RADIO DATA BOOK. Whether you use this book for general reference, for scientific instruction, or for education, one thing is certain—the practical help, the daily usefulness you will derive from it will prove to be worth many, many times its astonishingly low price.

**Here's a description of just ONE section — Section 5, Sound Systems:**

This section covers the planning, selection of components, and assembly of complete P.A. installations. Every type of unit and material used in a sound system is described and analyzed. Components are classed as to size and type of P.A. installations in which they should be used. Tables and charts are given from which to determine power and ratings. Microphone and speaker construction are described and illustrated in detail . . . placement in auditoriums, etc., for proper acoustical results is explained and illustrated. Patterns of the different types of microphones are illustrated as are the proper methods of wiring up the various units, etc.

The above is just one of the twelve big sections in the RADIO DATA BOOK. We wish we had room here to describe all twelve in detail, but just look over the list of sections, and you will see why this is the best radio handbook money can buy. Send in your order for the RADIO DATA BOOK today!

**COMING SOON!**

## THE VIDEO HANDBOOK

**Everything in Television in one Complete Textbook**

**Over 500 pages completely illustrated.**

This new handbook will be invaluable to everyone concerned with the technical aspect of Television. Everything from the basic theory of television through the design and characteristics of receivers to final installation, operation, and maintenance is covered. This is a completely new book that includes all of the latest developments in the field—the components discussed are of the newest design—the practical maintenance described is a result of intensive study of the equipment placed in operation during the past few months.

There are five completely illustrated sections in the VIDEO HANDBOOK, each over a hundred pages long.

The VIDEO HANDBOOK will be out October 15th, but we have received a flood of orders already. To insure your getting a copy in the first printing—mail your order now.

The VIDEO HANDBOOK is \$5.00 alone, or you can order it with the RADIO DATA BOOK and get both books at the special price of \$9.00. Send in the coupon today.

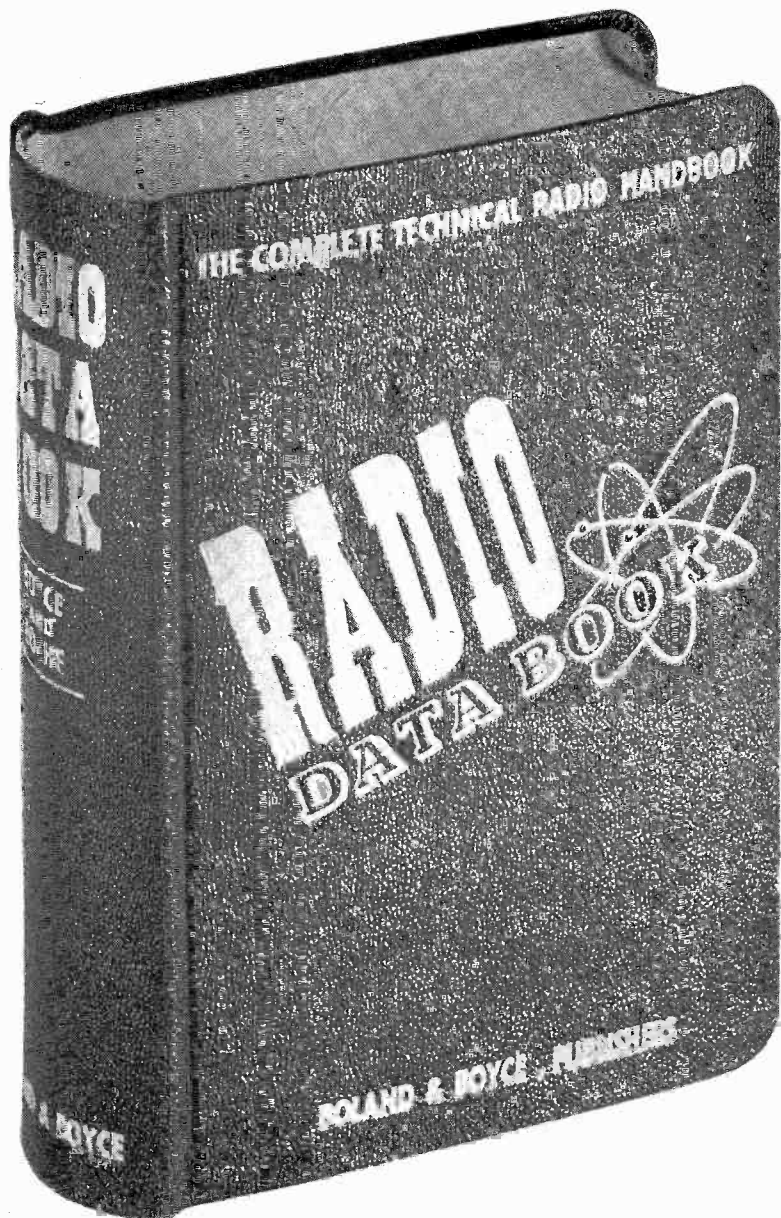

- 12 sections . . . 1000 pages . . . Completely illustrated
- Section 1. THE 150 BASIC CIRCUITS IN RADIO
  - Section 2. COMPLETE TEST EQUIPMENT DATA
  - Section 3. TESTING, MEASURING AND ALIGNMENT
  - Section 4. ALL ABOUT ANTENNAS
  - Section 5. SOUND SYSTEMS
  - Section 6. RECORDING
  - Section 7. COMPLETE TUBE MANUAL
  - Section 8. CHARTS, GRAPHS AND CURVES
  - Section 9. CODES, SYMBOLS AND STANDARDS
  - Section 10. 50 TESTED CIRCUITS DESIGNED FOR OPTIMUM PERFORMANCE
  - Section 11. DICTIONARY OF RADIO AND ELECTRONIC TERMS

**12 complete books in one only \$5.00!**  
**Less than 42c per book!**

**MAIL THIS COUPON TO YOUR JOBBER TODAY, OR DIRECT TO:  
BOLAND & BOYCE INC., PUBLISHERS  
460 BLOOMFIELD AVE., MONTCLAIR, N. J. RM-5**

- |  |   |
|--|---|
| <input type="checkbox"/> Enclosed is full amount.                                    | <input type="checkbox"/> Please send me the RADIO DATA BOOK at \$5.00. (\$5.50 foreign)       |
| <input type="checkbox"/> Enclosed is \$1.00, I will pay postman balance on delivery. | <input type="checkbox"/> Send me the VIDEO HANDBOOK at \$5.00. (\$5.50 foreign)               |
|  | <input type="checkbox"/> Send me BOTH books at the special price of \$9.00. (\$10.00 foreign) |

NAME .....  
ADDRESS .....  
STATE ..... ZONE ..... CITY .....

**BOLAND & BOYCE INC., PUBLISHERS**

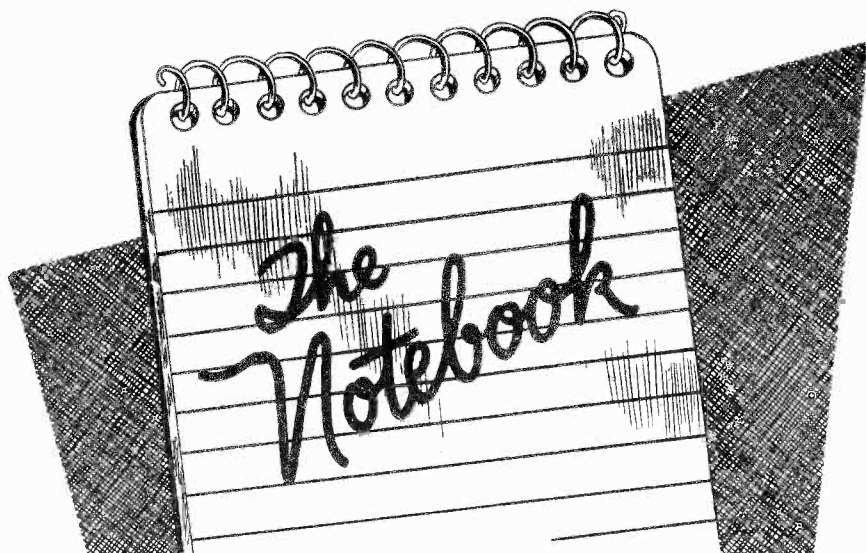

### NEW SIGHT FOR MAGIC EYE

Electron ray indicator tubes gradually lose their brilliance until they reach a point at which they are no longer useful. Their life may often be extended by the following procedure.

Hold the tube over the flame of a candle for about three minutes. During this time rotate it slowly. Allow the tube to cool slowly in an area free from drafts. The tube will then glow considerably brighter, and its useful life will be increased.

Marion L. Rhodes  
Knightstown, Indiana

### ZENITH MODEL 8G005YBT

Hum modulation, when this receiver is operated from the a.c. line, is often caused by leakage through the plywood case. This may be checked by disconnecting the loop leads from the chassis and then checking the resistance from the loop to the chassis. This resistance should be at least 2 megohms.

The hum may be removed by insu-

lating the line resistor plate from the small screws holding it to the top of the case.

Ralph H. Mercer  
Lake Worth, Florida

### WIRE RECORDERS

It will often be found that when a new spool of wire is first used on a wire recorder that the quality of the recording falls off considerably near the end of the spool. Investigation will reveal a collection of magnetic "dust" in the wire-groove of the recording head. A small paint-brush can be used to remove this and to restore the machine to normal operation.

I have only found this condition existing when a new spool of wire is used for the first time; so apparently the tiny magnetic particles are all deposited in the recording head during the first passage of the wire through it. Once this is cleaned off, no further attention is usually necessary until another new spool is used.

John T. Frye  
Logansport, Indiana



**Servicemen's choice!**  
in ...



- There's always a bumper crop of Cunninghams in Kansas because people in the Sunflower State are hep to the long life and top performance of Cunningham tubes in line and battery radios. You can cash in on the harvest by electing to use Cunninghams whenever new tubes are called for.

See your  
CUNNINGHAM DISTRIBUTOR  
ACME RADIO SUPPLY  
Topeka



**FOR A FINER TONE A WALDOM CONE**

**THE LARGEST MANUFACTURERS OF REPLACEMENT CONES**

**WALDOM**  
ELECTRONICS INCORPORATED  
911 N. LARRABEE • CHICAGO, ILL.

Write for FREE  
Reference Catalog  
No. 49



# BACK NUMBERS

GET THEM WHILE  
THEY LAST!

## JANUARY 1946

THE PROBLEMS OF ORGANIZATION  
TELEVISION RECEIVER INSTALLATION  
RADIO MAINTENANCE IN AVIATION  
USING THE OSCILLOGRAPH FOR  
DISTORTION MEASUREMENTS

## MARCH 1946

TROUBLESHOOTING TELEVISION RECEIVERS  
APPLICATIONS OF A LOW COST  
SIGNAL TRACER  
RADIO REPAIRMEN'S ASSOCIATIONS  
RADIO SERVICE ALONG THE AIRWAYS

## APRIL 1946

A MIDGET AUDIO FREQUENCY  
OSCILLATOR  
IF I WERE A SERVICEMAN  
AN EQUALIZED AMPLIFIER FOR  
MAGNETIC PICKUPS

## MAY 1946

PA SYSTEMS  
TEST PANEL FOR THE MODERN BENCH  
RINGING THE BELL

## JUNE-JULY 1946

FUNDAMENTALS OF TELEVISION  
VOLUME CONTROL TAPERS  
THE ELECTRONIC OHMMETER  
VECTOR ANALYSIS

## AUGUST 1946

AVC CIRCUITS  
FM TROUBLESHOOTING  
TELEVISION RECEIVER FUNDAMENTALS  
RECORD CHANGERS

## DECEMBER 1946

TELEVISION RECEIVERS . . .  
THE RF SECTION  
TUNING THE INDICATORS  
PART II—THE OSCILLOGRAPH . . .  
HOW TO USE IT  
REPLACING AUTO CABLES

## JANUARY 1947

SERVICING BY EAR  
TELEVISION RECEIVERS . . . VIDEO  
CHANNEL  
PART III THE OSCILLOGRAPH . . .  
HOW TO USE IT  
MINIATURE TUBE CHART

## FEBRUARY 1947

THE OSCILLOGRAPH . . . HOW TO USE  
IT PART IV  
TELEVISION RECEIVERS . . . THE SOUND  
CHANNEL  
THE AUDIO OSCILLATOR  
SELENIUM RECTIFIERS

Get these back numbers to help complete your file of RADIO MAINTENANCE magazines. These copies, plus the copies you will receive in the months to come will form a valuable reference library to which you will turn for assistance in your daily work. The articles are listed under each month's heading to help you select the ones you wish to order, or you may want to order all eighteen back numbers listed below for the special price of \$4.25 (a reduction of \$1.05!) Send in for these copies today—insert them in your RADIO MAINTENANCE binders and you'll have a first-rate service library!

## MARCH 1947

ANTENNAS . . . FM AND TELEVISION  
PART I  
SERVICING AUTOMATIC RECORD  
CHANGERS  
OSCILLATORS AND CONVERTERS  
TELEVISION RECEIVERS . . . THE VERTICAL  
SWEEP

## APRIL 1947

ANTENNAS . . . FM AND TELEVISION,  
PART II  
PHASE INVERTER CIRCUITS  
A UNIVERSAL SPEAKER  
TELEVISION RECEIVERS . . .  
THE HORIZONTAL SWEEP . . .

## MAY 1947

THE OPEN AND CLOSE CASES  
VOLTAGE DOUBLERS  
SIGNAL TRACER  
TELEVISION RECEIVERS . . .  
THE CATHODE RAY TUBE

## JUNE 1947

WHEN THE CUSTOMER ISN'T RIGHT  
TEST EQUIPMENT MAINTENANCE  
CRYSTAL CONTROLLED SIGNAL  
GENERATOR  
TELEVISION RECEIVERS . . .  
THE POWER SUPPLY

## JULY 1947

SERVICING FM RECEIVERS  
TEST EQUIPMENT MAINTENANCE, PART II  
TELEVISION RECEIVERS . . .  
FLYWHEEL SYNC

## AUGUST 1947

SPEAKER MATCHING  
TEST EQUIPMENT MAINTENANCE, PART III  
SERVICING FM RECEIVERS  
TELEVISION . . . HF POWER SUPPLIES

## JANUARY 1948

HOW TO IMPROVE YOUR SIGNAL  
TRACING TECHNIQUES  
SPECIAL FM CIRCUITS  
WHAT'S NEW IN VIDEO SECTIONS

## FEBRUARY 1948

USING SWEEP GENERATORS FOR  
FM ALIGNMENT PART I  
LET'S WORK TOGETHER  
VOLTAGE REGULATOR OPERATION  
TIME SAVERS

## MARCH 1948

HOW TO ELIMINATE HUM  
USING SWEEP GENERATORS FOR  
FM ALIGNMENT PART II  
LOW-COST TELEVISION  
AN FM SIGNAL SOURCE

## RADIO MAINTENANCE MAGAZINE

460 BLOOMFIELD AVE., MONTCLAIR, N. J.

Please send me the back numbers checked here . . .  January 1946  August 1946  March 1947  January 1948  
 March 1946  December 1946  April 1947  February 1948  
 April 1946  May 1947  March 1948

I am enclosing 35c for each copy, or \$2 for any 8 copies, or \$4.25 for all 18.  January 1947  June-July 1946  February 1947  July 1947  August 1947

Have selected 8 copies . . . enclosing \$2.00  Send me all 18 . . . enclosing \$4.25

NAME .....

ADDRESS .....

CITY .....

ZONE ..... STATE .....

## ADVERTISERS

A. G. Radio Parts Co. . . . .	45
Agency: Arthur Liebscher	
American Electrical Heater Co. . . . .	3
Agency: Dudgeon, Taylor & Bruske, Inc.	
American Sales Co. . . . .	39
Agency: The Schram Co.	
Walter Ashe Radio Co. . . . .	34
Agency: Ralph Smith Advertising Agency	
The Astatic Corp. . . . .	44
Agency: Wearstler Advertising, Inc.	
Capitol Radio Engineering Institute . . . . .	40
Agency: Henry J. Kaufman & Associates	
Centralab . . . . .	30, 31
Agency: Klau-Van Pietersom-Dunlap	
Concord Radio Corp. . . . .	38
Agency: E. H. Brown Advertising Agency	
Allen B. DuMont Laboratories, Inc. . . . .	35
Agency: Austin C. Lescarboursa & Staff	
Electro Products Laboratories . . . . .	33
Agency: Merrill Symonds Advertising Agency	
Federated Purchaser, Inc. . . . .	39
Agency: Bergman-Jarrett Co.	
Feiler Engineering Co. . . . .	38
Agency: Turner Advertising Agency	
General Electric Co. . . . . 2nd Cover, 10	
Agency: Maxon, Inc.	
Hytron Radio & Electronics Corp. . . . .	8
Agency: Henry A. Loudon, Advertising, Inc.	
Jensen Mfg. Co. . . . .	12
Agency: Burton Browne, Adv.	
P. R. Mallory & Co., Inc. . . . .	7
Agency: The Aitkin-Kynett Co.	
McMurdo Silver Co. . . . .	9
Agency: Edward Owen & Co.	
Mid-America Co., Inc. . . . .	32
Agency: E. H. Brown Adv. Agency	
Midway Radio Tube Co. . . . .	41
Ohmite Mfg. Co. . . . .	36
Agency: The Fensholt Co.	
Operadio Mfg. Co. . . . .	37
Agency: Kennedy & Co.	
Permoflux Corp. . . . .	43
Agency: Turner Advertising Agency	
Philco Corp. . . . .	13
Agency: Hutchins Adv. Agency	
Precision Apparatus Co. . . . .	14
Agency: Shappe-Wilkes, Inc.	
Radiart Corp. . . . .	15
Agency: Ohio Adv. Agency	
Radio Corporation of America . . . . .	41, 43, 44, 45, 47, 3rd Cover
Agency: J. Walter Thompson	
Raytheon Mfg. Co. . . . .	6
Agency: Walter B. Snow & Staff, Inc.	
John F. Rider, Publisher, Inc. . . . .	1
Agency: Lansford F. King, Adv.	
Howard W. Sams & Co., Inc. . . . .	29
Agency: George Brodsky Adv.	
Sangamo Electric Co. . . . .	11
Agency: Arthur R. Mogge, Inc.	
Sprague Products Co. . . . .	33
Agency: Harry P. Bridge Co.	
Sylvania Electric . . . . .	4
Agency: Newell-Emmett Co.	
Waldom Electronics Co. . . . .	47
Agency: The Schram Co.	
Ward Products Corp. . . . .	5
Agency: Burton Browne Adv.	
Webster-Chicago . . . . .	2, 28, 39
Agency: Fuller & Smith & Ross	



DESIGNED FOR THE BETTER SERVICE SHOP...

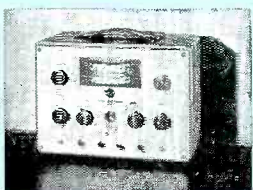
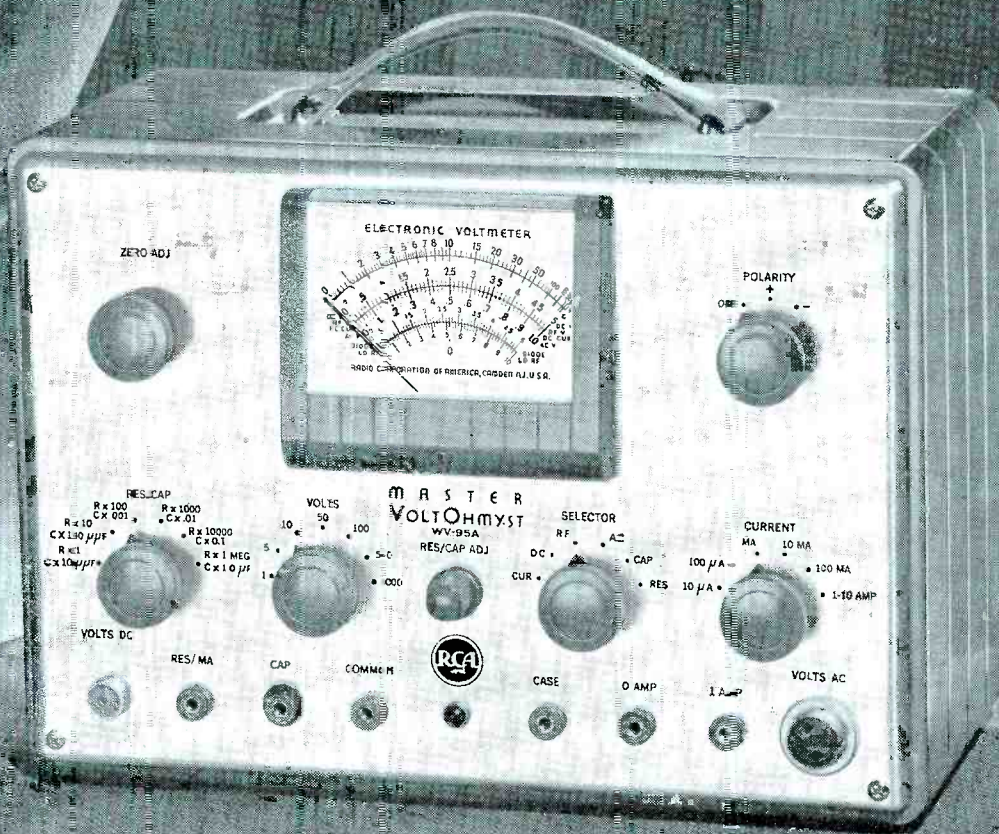

Audio Oscillator

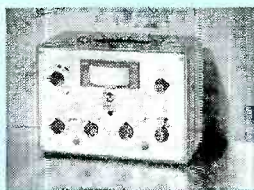

Test Oscillator

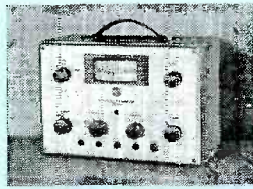

FM Sweep Generator

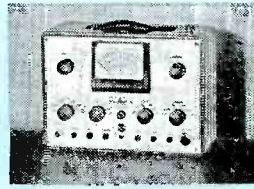

Master VoltOhmyst  
Electronic Meter

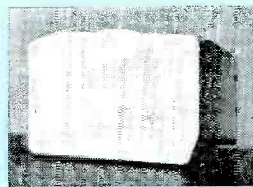

To Be Announced

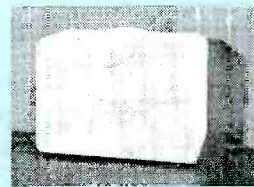

To Be Announced

READ NEW MASTER VOLTOHMYST ELECTRONIC METER  
... fourth unit of a revolutionary new line of test equipment

Measures capacitance, current, voltage, and resistance

**OUTSTANDING NEW FEATURES**

- Measures Capacitance—from 5 mmfd. to 1000 mfd.
- Measures dc current—from 1 micro-amp to 10 amps
- Has measuring circuits isolated from case
- Accessory crystal probe available—for routine measurements up to 100 Mc.
- Accessory diode probe available—for peak-to-peak measurements up to 250 Mc.
- Provides extra ac sensitivity—1 volt rms, full scale

In addition, the RCA Master Volt-Ohmyst Electronic Meter includes all features of the regular VoltOhmyst Electronic Meter. It's a dc voltmeter ... a dc current meter ... an ohmmeter ... an ac voltmeter ... an af voltmeter ... and an rf voltmeter.

\*"VoltOhmyst" is a registered trade mark of the Radio Corporation of America

Use the Master VoltOhmyst Electronic Meter to save time and increase profit on every radio or television job. It's the only single instrument capable of so many varied tests and measurements. It will give accurate readings despite line voltage fluctuations. Its million-to-one current range makes it useful as an electronic galvanometer. You can use it with the accessory crystal probe for rms readings to 100 Mc. or with the accessory diode probe for peak-to-peak readings to 250 Mc. The Master VoltOhmyst Electronic Meter is the most versatile VTVM available.

A new bulletin containing complete specifications on the Type WV-95A Master VoltOhmyst Electronic Meter is yours for the asking. See your RCA Test Equipment Distributor, or write RCA, Commercial Engineering, Section FX59, Harrison, N. J.



**RADIO CORPORATION of AMERICA**

**TEST AND MEASURING EQUIPMENT**

**HARRISON, N. J.**





**30,000**  
**Successful**  
**Servicemen**  
**use**  
**RADIO**  
**MAINTENANCE**  
**every day**

**RADIO MAINTENANCE** is one of the most valuable items among radio servicing tools. Using the proper tools speeds up work—increases profits. In every issue, **RADIO MAINTENANCE** presents articles and departments full of money-making ideas. Add it to your previous issues and form a complete service library. All your **RADIO MAINTENANCE** magazines are designed to form a reference library in themselves. Binders holding up to 18 copies each are now available for preserving your **RADIO MAINTENANCE** library — don't miss a single issue!

**RADIO MAINTENANCE MAGAZINE**

460 BLOOMFIELD AVE.

MONTCLAIR 1, N. J.