



THE M-O VALVE CO LTD

ENGLISH ELECTRIC VALVE CO LTD

Product Data

Hydrogen Thyratrons

Issued by

The GEC Electronic Tube Company Limited,

a Management Company which unites the activities of The M-O Valve Company Limited and English Electric Valve Company Limited.

English Electric Valve Company Limited

Waterhouse Lane, Chelmsford, Essex, CM1 2QU
Telephone: Chelmsford (0245) 61777 Telex: 99103

The M-O Valve Company Limited

Brook Green Works, Hammersmith, London W6 7PE
Telephone: 01-603 3431 Telex: 23435

Hydrogen Thyratrons



QUICK REFERENCE DATA

HYDROGEN THYRATRONS

GLASS ENVELOPE TYPES

EEV Type	Description	Peak output power max (MW)	Heating factor max (V.A.p.p.s.)	Peak forward voltage max (kV)	Peak anode current (mA)
6587	Triode	2.0	3.9×10^9	16	305
8503	Triode	2.6	3.9×10^9	16	305
CX1140	Tetrode	12.5	9.0×10^9	25	1000
CX1159	Tetrode	16.5	14×10^9	33	1000
CX1191	Tetrode	3.2	5.0×10^9	16	400
CX1191A	Tetrode	6.25	6.25×10^9	25	500
CX1191D	Tetrode	8.0	8.0×10^9	35	500
FX227	Triode	0.06	0.36×10^9	3.0	40
FX297	Triggered diode, p.i.v. 25 kV max.				500
FX2501	Triode	2.0	3.9×10^9	16	305
FX2503	Triggered diode, p.i.v. 33 kV max.				500
FX2505	Triode	0.5	2.8×10^9	10	50
FX2517	Triode	0.5	2.8×10^9	10	50
FX2519A/ 5949A	Triode	6.25	6.25×10^9	25	500
FX2525	Triode	1.6	3.0×10^9	15	200
FX2530/ 6777	Triode	0.34	2.5×10^9	5.0	50

CERAMIC ENVELOPE TYPES

EEV type*	Description	Peak output power max (MW)	Heating factor max (V.A.p.p.s.)	Peak forward voltage max (kV)	Peak anode current max (A)
CX1154	Tetrode	50	30×10^9	40	3000
CX1154B	Double ended	50	30×10^9	35	3000
CX1157	Tetrode	3.5	7.0×10^9	20	350
CX1164	Tetrode	2.1	7.0×10^9	12	350
CX1168	Two-gap tetrode	100	70×10^9	80	3000
CX1168B	Double ended	88	60×10^9	70	3000
CX1171	Three-gap tetrode	150	70×10^9	120	3000
CX1171B	Double ended	130	60×10^9	105	3000
CX1174	Tetrode	120	60×10^9	40	6000
CX1174B	Double ended	100	60×10^9	35	6000
CX1175	Two-gap tetrode	200	140×10^9	80	6000
CX1175B	Double ended	175	120×10^9	70	6000
CX1177	Tetrode	0.9	4.0×10^9	12	150
CX1180	Tetrode	12.5	12.5×10^9	25	1000
CX1192	Three-gap tetrode	360	140×10^9	120	6000
CX1192B	Double ended	260	120×10^9	105	6000
CX1193	Four-gap tetrode	400	140×10^9	160	6000
CX1193B	Double ended	350	120×10^9	140	6000
CX1199	Four-gap tetrode	200	70×10^9	160	3000
CX1199B	Double ended	175	60×10^9	140	3000
CX1535	Pentode	12.5	500×10^9	25	1000
CX1536	Two-gap tetrode	350	300×10^9	70	10 000
FX2507/ 8613	Triode	4.0	10×10^9	16	500
FX2531	Triode	1.2	7.2×10^9	16	150

METAL ENVELOPE TYPES – Pulse Modulator Service

EEV type	Description	Peak output power max (MW)	Heating factor max (V.A.p.p.s.)	Peak forward voltage max (kV)	Peak anode current max (A)
CX1525	Tetrode	100	100×10^9	70	3500
CX1526A	Tetrode	70	70×10^9	40	3500
CX1527A	Tetrode	200	200×10^9	40	10 000
CX1528	Tetrode	70	70×10^9	40	3500
CX1529	Tetrode	200	200×10^9	40	10 000

METAL ENVELOPE TYPES – Inverter Service

EEV type	Description	Output power per pair (kW)	Peak anode voltage (kV)	Average anode current max (A)	Peak anode current max (A)
CX1526B	Tetrode	320	40	20	40
CX1527B	Tetrode	1000	40	60	120



**HYDROGEN
THYRATRON**

The data to be read in conjunction with the Hydrogen Thyatron Preamble.

ABRIDGED DATA

Hydrogen-filled triode thyatron, positive grid, for pulse operation. A hydrogen reservoir is incorporated. The tube is ruggedized to meet the requirements of airborne applications. Environmental tests applied to the tube comply with those of the CV6022 specification and include linear acceleration at 12g, and vibration at ¼g minimum acceleration and 150Hz frequency or at the frequency of maximum resonance in the range between 10 and 150Hz.

The tube complies with MIL-E-1/1046.

Peak forward anode voltage	16	kV max
Peak anode current	325	A max
Average anode current	225	mA max
Anode heating factor	3.9×10^9	V.A.p.p.s. max
Peak output power	2.0	MW max

GENERAL

Electrical

Cathode (connected internally to one end of heater)	oxide coated
Heater voltage	$6.3 \pm 7\frac{1}{2}\%$ V
Heater current	10.6 A
Tube heating time (minimum)	3.0 min

Mechanical

Overall length	7.250 inches (184.2mm) max
Overall diameter	2.563 inches (65.1mm) max
Net weight	12 ounces (340g) approx
Mounting position	any
Clamping	see note 1
Base	B4D, bayonet
Top cap	B.S.448-CT3

Cooling	natural
--------------------------	---------

PULSE MODULATOR SERVICE

MAXIMUM AND MINIMUM RATINGS (Absolute values)

	Min	Max	
Anode			
Peak forward anode voltage (see note 2)	—	16	kV
Peak inverse anode voltage (see note 3)	—	16	kV
Peak anode current	—	325	A
Average anode current	—	225	mA
Rate of rise of anode current (see note 4)	—	1500	A/ μ s
Anode heating factor	—	3.9×10^9	V.A.p.p.s.

Grid

Unloaded grid drive pulse voltage (see note 5)	200	—	V
Grid pulse duration	2.0	—	μ s
Rate of rise of grid pulse (see note 4)	180	—	V/ μ s
Peak inverse grid voltage	—	200	V
Loaded grid bias voltage	0	-120	V
Forward impedance of grid drive circuit	—	500	Ω

Cathode

Heater voltage	$6.3 \pm 7\frac{1}{2}\%$	—	V
Tube heating time	3.0	—	min

Environmental

Environmental performance	—	—	see note 6
Ambient temperature	-50	+90	$^{\circ}$ C
Altitude	—	10 000	ft
	—	3	km

CHARACTERISTICS

	Min	Typical	Max	
Critical d.c. anode voltage for conduction (see note 7)	—	0.3	1.0	kV
Anode delay time (see notes 7 and 8)	—	0.3	0.65	μ s
Anode delay time drift (see notes 7 and 9)	—	0.05	0.1	μ s
Time jitter (see notes 7 and 10)	—	3.0	5.0	ns
Recovery time	—	—	—	see note 11 and curves
Heater current (at 6.3V)	9.6	10.6	11.6	A
Additional tests	—	—	—	see note 12

NOTES

1. The tube should preferably be clamped by the base only. Any clamps used on the bulb must not extend beyond $4\frac{1}{4}$ inches (108mm) above the top of the base and should be made from material of low thermal conductivity.
2. This is the maximum forward hold-off voltage imposed on the thyratron in a pulse modulator circuit. Tubes are tested at 18kV peak forward anode voltage, with the charging reactor inductance and pulse forming network capacitance resonant at 1000p.p.s. For instantaneous starting applications the maximum permissible peak forward voltage is 13.5kV; this must not be reached in less than 0.04 second and there must be no overshoot.
3. In pulsed operation the peak inverse anode voltage, exclusive of a spike of 0.05 microsecond duration, must not exceed 5.0kV during the first 25 microseconds after the pulse.
4. This rate of rise refers to that part of the leading edge of the pulse between 25% and 75% of the pulse amplitude.
5. Measured with respect to cathode potential.
6. All tubes are subjected to an acceleration of 10g at 50Hz before testing. In addition, samples are tested under the following conditions:
 - (a) **Linear Acceleration** 12g (min) is applied and maintained for 1 minute at right angles to and in each direction along the major axis of the tube. A heater voltage of 6.3V is applied during the test.
 - (b) **Resonance Search** Vibration is applied in two mutually perpendicular directions, one of which is parallel to the longitudinal axis of the tube. The frequency is swept at a rate not exceeding one octave per minute between 10 and 150Hz, with accelerations of $\frac{1}{4}$ g (min). All resonances detectable visually or electrically are noted for information and also for use in test (c). Normal operating voltages are applied during the test.
 - (c) **Vibration Fatigue** Each tube is subjected to vibration for two periods of ten hours. In one period the direction of vibration is parallel to the longitudinal axis of the tube, and in the other the direction is perpendicular to the longitudinal axis of the tube.

The acceleration is $\frac{1}{4}g$ and the frequency is that of the strongest resonance detected during the resonance search. If no resonances were detected in the search, then a frequency of 150Hz is used. A heater voltage of 6.3V is applied during the test.

Tubes must pass operational tests after the above procedure has been completed.

7. The typical figures are obtained on test using conditions of minimum grid drive. Improved performance can be expected by increasing the grid drive.
8. The time interval between a point on the leading edge of the unloaded grid pulse at 25% of the pulse amplitude and the point where anode conduction takes place.
9. Normally taken as the drift in delay time over a 5-minute run at full ratings between the second and seventh minutes of operation.
10. The variation of firing time measured at 50% of current pulse amplitude.
11. The recovery characteristics are controlled on a sampling basis.
12. In addition to operational testing at pulse repetition rates of 800 and 1000p.p.s. on all tubes, an additional test at 2500p.p.s., 12.5kV, is performed on a sampling basis.

X-RAY WARNING

X-rays are emitted by the 6587 from the region of the anode, but the radiation is usually reduced to a safe level by the metal panels of the equipment in which the tube operates.

MAXIMUM RECOVERY CHARACTERISTICS

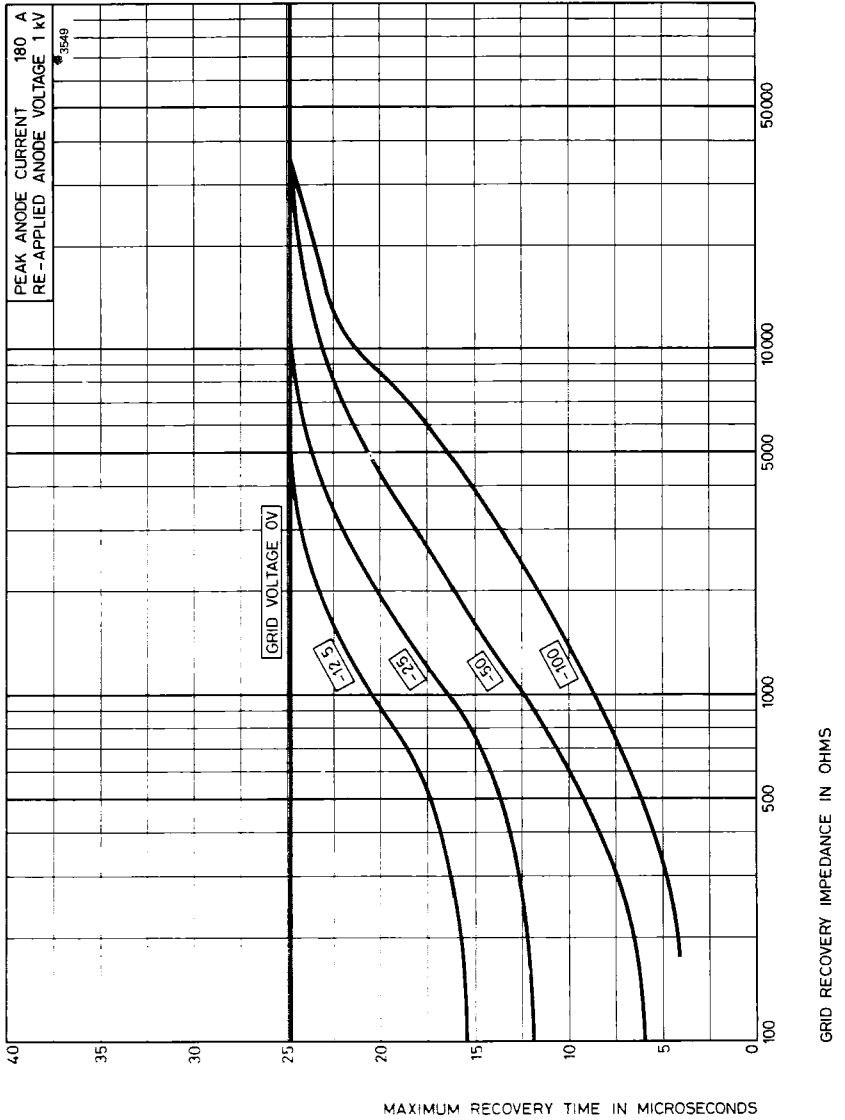

OUTLINE (All dimensions without limits are nominal)

3550

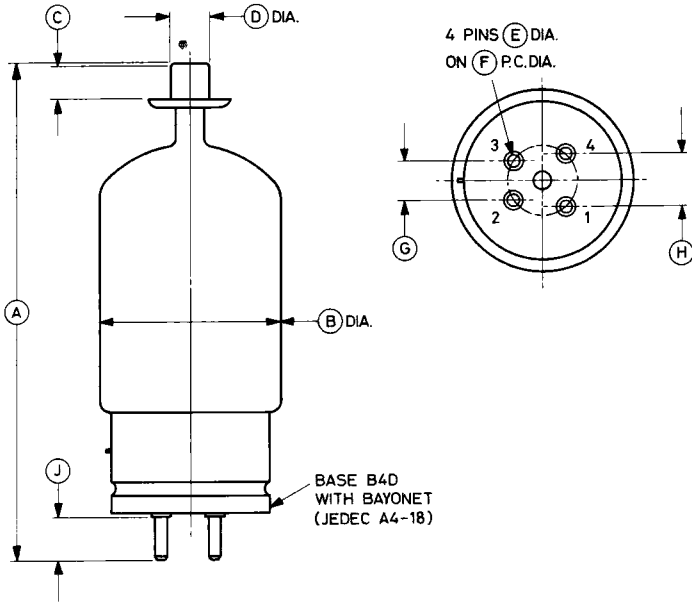

Ref	Inches	Millimetres
A	7.000 ± 0.250	177.8 ± 6.4
B	2.563 max	65.10 max
C	0.375 min	9.53 min
D	0.566 ± 0.007	14.38 ± 0.18
E	0.187 ± 0.003	4.750 ± 0.076
F	1.000	25.40
G	0.562	14.27
H	0.750	19.05
J	0.625	15.88

Pin	Element
1	Grid
2	Heater, cathode
3	Heater
4	Cathode
Top cap	Anode

Millimetre dimensions have been derived from inches.

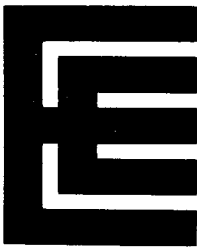

HYDROGEN THYRATRON

Service Type CV6022

The data to be read in conjunction with the Hydrogen Thyatron Preamble.

ABRIDGED DATA

Hydrogen-filled triode thyatron, positive grid, for pulse operation. A hydrogen reservoir is incorporated. Electrically superior to 5C22 and ruggedized to meet the requirements of airborne applications. Environmental tests applied to the tube include linear acceleration at 12g, and vibration at ¼g minimum acceleration and 150Hz frequency or at the frequency of maximum resonance in the range between 10 and 150Hz.

Peak forward anode voltage	16	kV max
Peak anode current	325	A max
Average anode current	250	mA max
Anode heating factor	3.9×10^9	V.A.p.p.s. max
Peak output power	2.6	MW max

GENERAL

Electrical

Cathode (connected internally to one end of heater)	oxide coated
Heater voltage	$6.3 \pm 7.5\%$ V
Heater current	10.6 A
Tube heating time (minimum)	3.0 min

Mechanical

Overall length	8.750 inches (222.3mm) max
Overall diameter	2.563 inches (65.1mm) max
Net weight	12 ounces (350g) approx
Mounting position	any
Clamping	see note 1
Base	B4D, bayonet
Top cap	B.S.448-CT3

Cooling	natural
--------------------------	---------

PULSE MODULATOR SERVICE

MAXIMUM AND MINIMUM RATINGS (Absolute values)

	Min	Max	
Anode			
Peak forward anode voltage (see note 2)	—	16	kV
Peak inverse anode voltage (see note 3)	—	16	kV
Peak anode current	—	325	A
Average anode current	—	250	mA
Rate of rise of anode current (see note 4)	—	1500	A/ μ s
Anode heating factor	—	3.9×10^9	V.A.p.p.s.

Grid

Unloaded grid drive pulse voltage (see note 5)	200	—	V
Grid pulse duration	2.0	—	μ s
Rate of rise of grid pulse (see note 4)	180	—	V/ μ s
Peak inverse grid voltage	—	200	V
Loaded grid bias voltage	0	-120	V
Forward impedance of grid drive circuit	50	500	Ω

Cathode

Heater voltage	$6.3 \pm 7\frac{1}{2}\%$	—	V
Tube heating time	3.0	—	min

Environmental

Environmental performance			see note 6
Ambient temperature	-50	+90	$^{\circ}$ C
Altitude	—	10 000	ft
	—	3	km

CHARACTERISTICS

	Min	Typical	Max	
Critical d.c. anode voltage for conduction (see note 7)	—	0.3	1.0	kV
Anode delay time (see notes 7 and 8)	—	0.3	0.65	μ s
Anode delay time drift (see notes 7 and 9)	—	0.05	0.1	μ s
Time jitter (see notes 7 and 10)	—	3.0	5.0	ns
Recovery time				see note 11 and curves
Heater current (at 6.3V)	9.6	10.6	11.6	A
Additional tests				see note 12

NOTES

1. The tube should preferably be clamped by the base only. Any clamps used on the bulb must not extend beyond $4\frac{1}{4}$ inches (108mm) above the top of the base and should be made from material of low thermal conductivity.
2. This is the maximum forward hold-off voltage imposed on the thyatron in a pulse modulator circuit. Tubes are tested at 18kV peak forward anode voltage, with the charging reactor inductance and pulse forming network capacitance resonant at 1000p.p.s. For instantaneous starting applications the maximum permissible peak forward voltage is 13.5kV; this must not be reached in less than 0.04 second and there must be no overshoot.
3. In pulsed operation the peak inverse anode voltage, exclusive of a spike of 0.05 microsecond duration, must not exceed 5.0kV during the first 25 microseconds after the pulse.
4. This rate of rise refers to that part of the leading edge of the pulse between 25% and 75% of the pulse amplitude.
5. Measured with respect to cathode potential.
6. All tubes are subjected to an acceleration of 10g at 50Hz before testing. In addition, samples are tested under the following conditions:
 - (a) **Linear Acceleration** 12g (min) is applied and maintained for 1 minute at right angles to and in each direction along the major axis of the tube. A heater voltage of 6.3V is applied during the test.
 - (b) **Resonance Search** Vibration is applied in two mutually perpendicular directions, one of which is parallel to the longitudinal axis of the tube. The frequency is swept at a rate not exceeding one octave per minute between 10 and 150Hz, with accelerations of $\frac{1}{4}$ g (min). All resonances detectable visually or electrically are noted for information and also for use in test (c). Normal operating voltages are applied during the test.
 - (c) **Vibration Fatigue** Each tube is subjected to vibration for two periods of ten hours. In one period the direction of vibration is parallel to the longitudinal axis of the tube, and in the other the direction is perpendicular to the longitudinal axis of the tube.

The acceleration is $\frac{1}{4}g$ and the frequency is that of the strongest resonance detected during the resonance search. If no resonances were detected in the search, then a frequency of 150Hz is used. A heater voltage of 6.3V is applied during the test.

• Tubes must pass operational tests after the above procedure has been completed.

7. The typical figures are obtained on test using conditions of minimum grid drive. Improved performance can be expected by increasing the grid drive.
8. The time interval between a point on the leading edge of the unloaded grid pulse at 25% of the pulse amplitude and the point where anode conduction takes place.
9. Normally taken as the drift in delay time over a 5-minute run at full ratings between the second and seventh minutes of operation.
10. The variation of firing time measured at 50% of current pulse amplitude.
11. The recovery characteristics are controlled on a sampling basis.
12. In addition to operational testing at pulse repetition rates of 800 and 1000p.p.s. on all tubes, an additional test at 2500p.p.s., 12.5kV, is performed on a sampling basis.

X-RAY WARNING

X-rays are emitted by the 8503 from the region of the anode, but the radiation is usually reduced to a safe level by the metal panels of the equipment in which the tube operates.

MAXIMUM RECOVERY CHARACTERISTICS

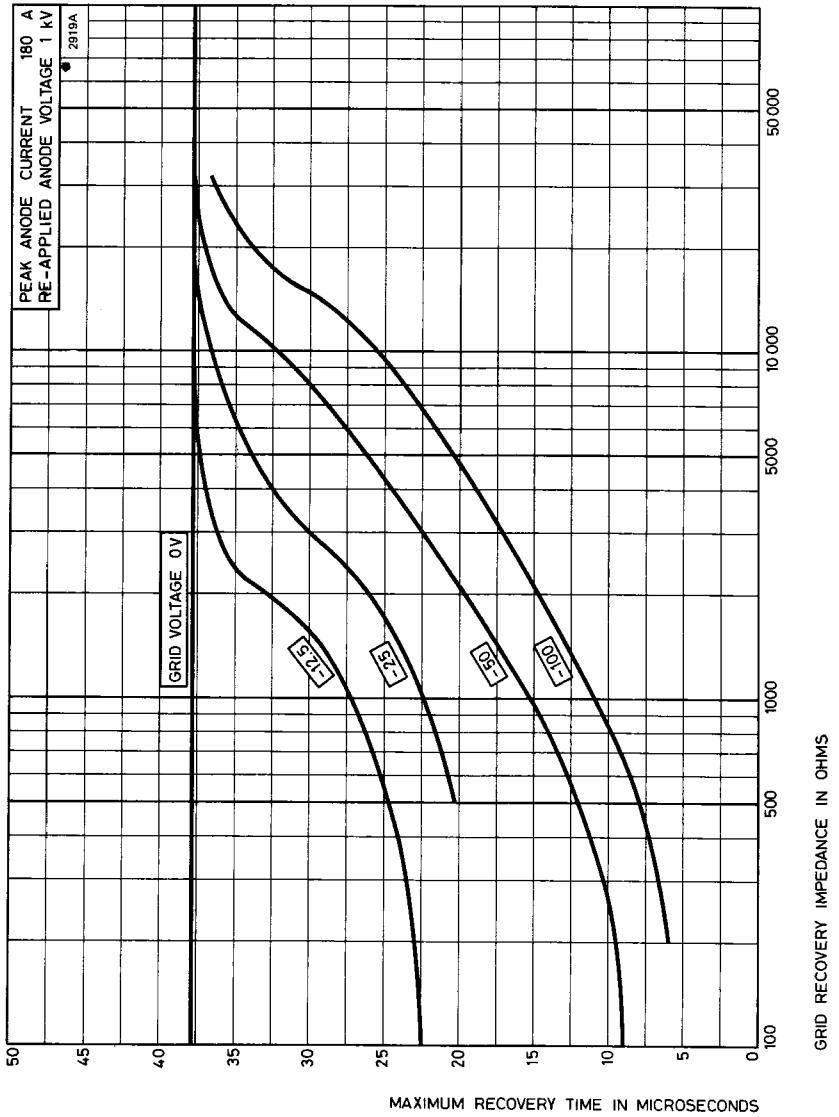

OUTLINE (All dimensions without limits are nominal)

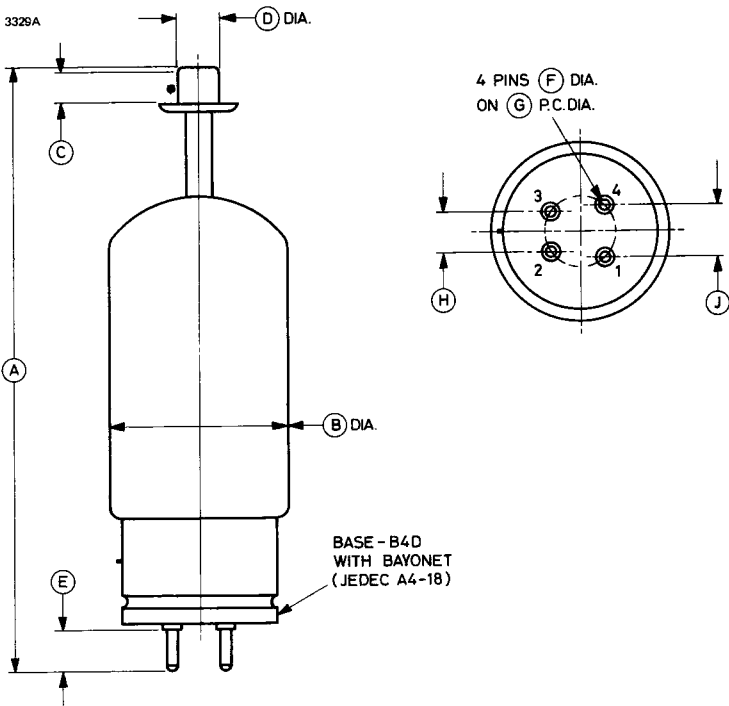

Ref	Inches	Millimetres
A	8.500 ± 0.250	215.9 ± 6.4
B	2.563 max	65.10 max
C	0.375 min	9.53 min
D	0.566 ± 0.007	14.38 ± 0.18
E	0.625	15.88
F	0.187 ± 0.003	4.750 ± 0.076
G	1.000	25.40
H	0.562	14.27
J	0.750	19.05

Pin	Element
1	Grid
2	Heater, cathode
3	Heater
4	Cathode
Top cap	Anode

Millimetre dimensions have been derived from inches.



HYDROGEN THYRATRON

Service Type CV8563

The data to be read in conjunction with the Hydrogen Thyatron Preamble.

ABRIDGED DATA

Hydrogen-filled tetrode thyatron, featuring low jitter and low anode delay time drift. Suitable for use at high pulse repetition rates, in parallel for switching higher powers, or for switching long pulses. A reservoir operating from the cathode heater supply is incorporated. The CX1140 replaces many less sophisticated thyatrons of similar rating when used with base adaptors obtainable from EEV. Details of these adaptors are given on page 5.

Peak forward anode voltage	25	kV max
Peak anode current (see page 2)	1000	A max
Average anode current	1.25	A max
Anode heating factor	9.0×10^9	V.A.p.s. max
Peak output power	12.5	MW max

GENERAL

Electrical

Cathode (connected internally to mid-point of heater)	oxide coated
Heater voltage	$6.3 \pm 5\%$ V
Heater current	22 A
Tube heating time (minimum)	5.0 min
Inter-electrode capacitances (approximate):	
anode to grid 2 (grid 1 and cathode not connected)	13 pF
anode to grid 1 (grid 2 and cathode not connected)	7.5 pF
anode to cathode (grid 1 and grid 2 not connected)	26 pF

Mechanical

Overall length	12.500 inches (317.5mm) max
Overall diameter	3.312 inches (84.12mm) max
Net weight	1½ pounds (0.7kg) approx
Mounting position (see note 1)	any
Base	pin spacing as B5F; metal shell with micaalex insert
Top cap (see note 2)	B.S.448-CT3

Cooling natural

PULSE MODULATOR SERVICE

MAXIMUM AND MINIMUM RATINGS (Absolute values)

	Min	Max	
Anode			
Peak forward anode voltage (see note 3)	—	25	kV
Peak inverse anode voltage (see note 4)	—	25	kV
Peak anode current	—	1000	A
Peak anode current (pulse repetition rate limited to 60p.p.s. max)	—	2000	A
Average anode current	—	1.25	A
Rate of rise of anode current (see note 5)	—	5000	A/ μ s
Anode heating factor	—	9.0×10^9	V.A.p.p.s.
Grid 2			
Unloaded grid 2 drive pulse voltage (see note 6)	200	1000	V
Grid 2 pulse duration	1.0	—	μ s
Rate of rise of grid 2 pulse (see note 5)	1.0	—	kV/ μ s
Grid 2 pulse delay	0.5	3.0	μ s
Peak inverse grid 2 voltage	—	450	V
Loaded grid 2 bias voltage	-50	-150	V
Forward impedance of grid 2 drive circuit	50	800	Ω
Grid 1 — D.C. Primed (See note 7)			
D.C. grid 1 unloaded priming voltage	75	150	V
D.C. grid 1 priming current	50	100	mA
Grid 1 — Pulsed			
Unloaded grid 1 drive pulse voltage (see note 6)	300	1000	V
Grid 1 pulse duration	2.0	—	μ s
Rate of rise of grid 1 pulse (see note 5)	1.0	—	kV/ μ s
Peak inverse grid 1 voltage	—	450	V
Loaded grid 1 bias voltage	—	—	see note 8
Peak grid 1 drive current	0.3	1.0	A
Cathode			
Heater voltage	—	$6.3 \pm 5\%$	V
Tube heating time	5.0	—	min
Environmental			
Ambient temperature	-50	+90	$^{\circ}$ C
Altitude	—	10 000	ft
	—	3	km

CHARACTERISTICS

	Min	Typical	Max	
Critical d.c. anode voltage for conduction (see note 9)	—	0.5	2.0	kV
Anode delay time (see notes 9 and 10)	—	0.15	0.25	μ s
Anode delay time drift (see notes 9, 11 and 12)	—	20	50	ns
Time jitter (see notes 9 and 12)	—	1.0	5.0	ns
Recovery time				see note 13 and curves
Heater current (at 6.3V)	18	22	25	A

RATINGS FOR SINGLE SHOT OR CROWBAR SERVICE (See note 7)

D.C. forward anode voltage	25	kV max
Peak anode current	15 000	A max
Product of peak current and pulse length	0.6	A.s max
Repetition frequency	1 pulse per 10s	max

NOTES

1. Clamping is only permissible by the base.
2. A large area anode connector EEV type MA360 is recommended.
3. The maximum permissible peak forward voltage for instantaneous starting is 20kV and there must be no overshoot.
4. The peak inverse voltage must not exceed 10kV for the first 25 microseconds after the anode pulse.
5. This rate of rise refers to that part of the leading edge of the pulse between 25% and 75% of the pulse amplitude.
6. Measured with respect to cathode. In certain cases the maximum drive pulse voltage may be exceeded without damage to the tube; a maximum value of 2.5kV is then recommended. When grid 1 is pulse driven, the last 0.25 μ s of the top of the grid 1 pulse must overlap the corresponding first 0.25 μ s of the top of the delayed grid 2 pulse.

7. When d.c. priming is used on grid 1, a negative bias of 100 to 200V must be applied to grid 2 to ensure anode voltage hold-off. D.C. priming is recommended for crowbar service.
8. D.C. negative bias voltages must not be applied to grid 1. When grid 1 is pulse driven, the potential of grid 1 may vary between -10 and $+5V$ with respect to cathode potential during the period between the completion of recovery and the commencement of the succeeding grid pulse.
9. Typical figures are obtained on test using conditions of minimum grid drive. Improved performance can be expected by increasing the grid drive.
10. The time interval between the instant at which the rising unloaded grid 2 pulse reaches 25% of its pulse amplitude and the instant when anode conduction takes place.
11. The drift in delay time over a period from 10 seconds to 10 minutes after reaching full voltage.
12. For equipment where jitter and anode delay time drift are not important, the tube may be triggered by applying a single pulse to grid 2 and connecting grid 1 to grid 2 via a 100pF capacitor shunted by a $10M\Omega$ resistor. These components are incorporated in adaptor assemblies MA92 and MA179 (see page 5).
13. The recovery characteristics are controlled on a sampling basis.

X-RAY WARNING

X-rays are emitted by the CX1140 from the region of the anode, but the radiation is usually reduced to a safe level by the steel panels of the equipment in which the tube operates.

ADAPTOR ASSEMBLIES

In addition to standard top cap connectors and base sockets, a number of adaptor assemblies are available from English Electric Valve Company Ltd. They assist in the replacement of other types of thyatron by CX1140, as indicated below.

MA91 For replacing GHT3/CV5721.

A five-contact socket fitted with flexible leads and terminal tags, and mounted on an insulating base plate. It provides a conversion from base to flange type mounting.

MA92 For replacing 1754/5948 (CV3518).

Similar to MA91 but incorporates an RC network and is designed for use with CX1140 where a single pulse drive and flying lead connections are required. Where CX1140 and MA92 replace 1754/5948 (CV3518), it should be noted that no lead is provided for a hydrogen reservoir connection as the CX1140 does not require a separate supply.

MA179 For replacing 1754/5948 and with tube clamping.

A five-contact socket with flexible leads and terminal tags, mounted on an insulating base plate; it is fitted with a base clamp. It incorporates an RC network and is designed for use with CX1140 where a single pulse drive and flying lead connections are required.

See page 6 for conversion of 5949/1907 or 5949A socket to use CX1140.

Further information is contained in the leaflet 'Accessories for Hydrogen Thyratrons'.

Conversion of 5949/1907 or 5949A socket to use CX1140/CV8563

1) View of 5949/1907 or 5949A socket from underneath

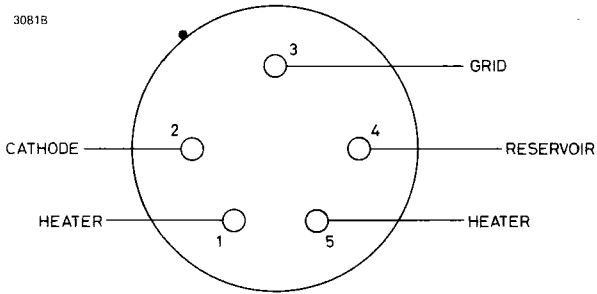

2) View of 5949/1907 or 5949A socket modified to use CX1140

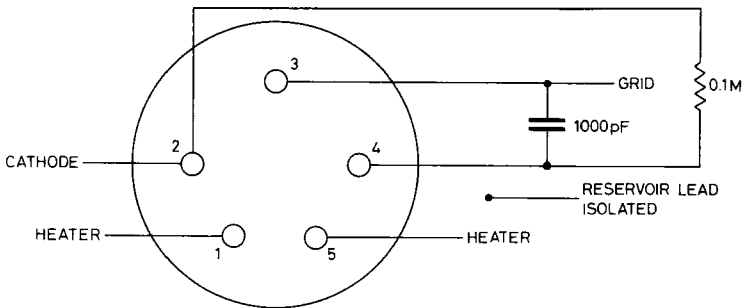

3) Conversion Procedure

The following components are required; they should be rated to withstand the existing grid drive power.

One $0.1M\Omega$ resistor.

One 1000pF mica capacitor.

- Remove reservoir lead from pin 4 and isolate.
- Connect the $0.1M\Omega$ resistor and 1000pF capacitor in parallel between pins 3 and 4.
- Plug in CX1140.

MAXIMUM RECOVERY CHARACTERISTICS

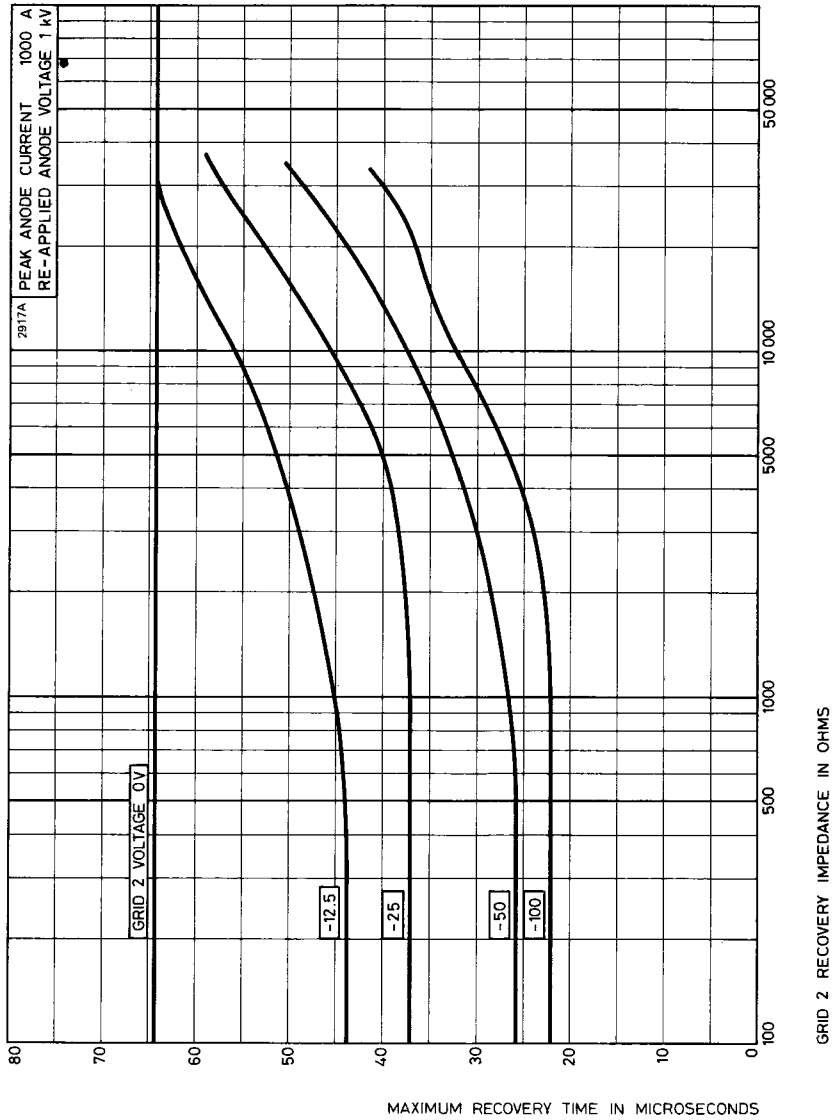

Whilst EEV has taken care to ensure the accuracy of the information contained herein it accepts no responsibility for the consequences of any use thereof and also reserves the right to change the specification of goods without notice. EEV accepts no liability beyond that set out in its standard conditions of sale in respect of infringement of third party patents arising from the use of tubes or other devices in accordance with information contained herein.

OUTLINE (All dimensions without limits are nominal)

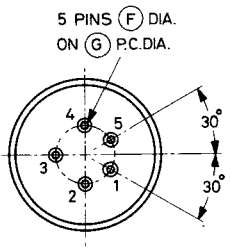
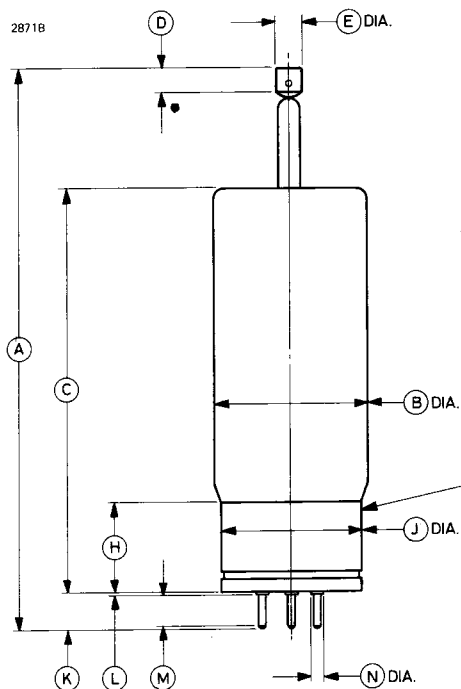

BASE PIN SPACING
AS B5F. METAL SHELL
WITH MICALEX INSERT

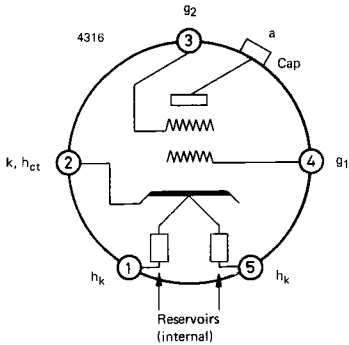

Ref	Inches	Millimetres
A	12.000 ± 0.500	304.8 ± 12.7
B	3.312 max	84.12 max
C	8.500 ± 0.500	215.9 ± 12.7
D	0.500 min	12.70 min
E	0.566 ± 0.007	14.38 ± 0.18
F	0.187 ± 0.003	4.750 ± 0.076
G	1.250	31.75
H	1.937	49.20
J	3.062 ± 0.062	77.77 ± 1.57
K	0.770 max	19.56 max
L	0.073 max	1.85 max
M	0.575 min	14.60 min
N	0.260 max	6.60 max

Pin	Element
1	Heater
2	Cathode, connected internally to heater mid-point
3	Grid 2
4	Grid 1
5	Heater
Top cap	Anode

Millimetre dimensions have been derived from inches.



DEUTERIUM-FILLED CERAMIC THYRATRON

The data to be read in conjunction with the Hydrogen Thyatron Preamble.

ABRIDGED DATA

Deuterium-filled tetrode thyatron with ceramic/metal envelope, featuring low jitter, firing time and drift. Suitable for switching high power at high pulse repetition rates or for switching long pulses. A reservoir operating from a separate heater supply is incorporated.

Peak forward anode voltage	40	kV max
Peak anode current (see page 2)	3000	A max
Average anode current	3.0	A max
Anode heating factor	30×10^9	V.A.p.p.s. max
Peak output power	50	MW max

GENERAL

Electrical

Cathode (connected internally to one end of heater)	oxide coated
Cathode heater voltage	$6.3 \pm 5\%$ V
Cathode heater current	21.5 A
Reservoir heater voltage (see note 1)	5.0 V
Reservoir heater current	7.0 A
Tube heating time (minimum)	15 min
Anode to grid 2 capacitance	15 to 20 pF

Mechanical

Seated height	6.500 inches (165.1mm) max
Clearance required below mounting flange	2.000 inches (50.8mm) min
Overall diameter (mounting flange)	4.375 inches (111.1mm) nom
Net weight	4 pounds (1.8kg) approx
Mounting position (see note 2)	any
Tube connections	see outline

Cooling	forced-air or liquid
Forced-air	see note 3
Liquid	oil or coolant immersion
Maximum temperature of envelope	200 °C

Natural ambient* cooling is usually insufficient to maintain the ceramic/metal envelope temperature below the maximum value specified above. Cooling by oil or coolant immersion is advised in view of the high voltages present. Further information is contained in the relevant section of the Preamble.

PULSE MODULATOR SERVICE

MAXIMUM AND MINIMUM RATINGS (Absolute values)

	Min	Max	
Anode			
Peak forward anode voltage (see note 4)	—	40	kV
Peak inverse anode voltage (see note 5)	—	40	kV
Peak anode current	—	3000	A
Peak anode current (pulse repetition rate limited to 60p.p.s. max)	—	4000	A
Average anode current	—	3.0	A
Rate of rise of anode current (see notes 6 and 7)	—	5000	A/μs
Anode heating factor	—	30 x 10 ⁹	V.A.p.p.s.

Grid 2

Unloaded grid 2 drive pulse voltage (see note 8)	200	1000	V
Grid 2 pulse duration	1.0	—	μs
Rate of rise of grid 2 pulse (see note 7)	1.0	—	kV/μs
Grid 2 pulse delay	0.5	3.0	μs
Peak inverse grid 2 voltage	—	450	V
Loaded grid 2 bias voltage (see note 9)	-50	-200	V
Forward impedance of grid 2 drive circuit	50	1000	Ω

Grid 1 – D.C. Primed (See note 10)

D.C. grid 1 unloaded priming voltage	75	150	V
D.C. grid 1 priming current	75	150	mA

MAXIMUM AND MINIMUM RATINGS – continued

Grid 1 – Pulsed

	Min	Max	
Unloaded grid 1 drive pulse voltage (see note 8)	300	1000	V
Grid 1 pulse duration	2.0	—	μ s
Rate of rise of grid 1 pulse (see note 7)	1.0	—	kV/ μ s
Peak inverse grid 1 voltage	—	450	V
Loaded grid 1 bias voltage	—	—	see note 11
Peak grid 1 drive current	0.3	1.0	A

Cathode

Heater voltage	6.3 \pm 5%	—	V
Heating time	15	—	min

Reservoir

Heater voltage (see note 1)	4.5	6.5	V
Heating time	15	—	min

Environmental

Ambient temperature	–50	+90	$^{\circ}$ C
Altitude	—	10 000	ft
	—	3	km

CHARACTERISTICS

	Min	Typical	Max	
Critical d.c. anode voltage for conduction (see note 12)	—	0.5	1.0	kV
Anode delay time (see notes 12 and 13)	—	0.1	0.25	μ s
Anode delay time drift (see notes 12 and 14)	—	15	50	ns
Time jitter (see note 12)	—	1.0	5.0	ns
Cathode heater current (at 6.3V)	18	21.5	25	A
Reservoir heater current (at 5.0V)	6.0	7.0	9.0	A

RATINGS FOR SINGLE SHOT OR CROWBAR SERVICE (See note 10)

D.C. forward anode voltage	35	kV max
Peak anode current	15 000	A max
Product of peak current and pulse length	0.1	A.s max
Repetition frequency	1 pulse per 10s	max

NOTES

1. The reservoir heater must be decoupled with a suitable capacitor to avoid damage by spike voltages. The recommended reservoir heater voltage is stamped on individual tube envelopes.
2. The tube must be mounted by means of its mounting flange.
3. An adequate flow of air must be supplied to maintain the ceramic/metal envelope temperature below the maximum rated value.
4. The maximum permissible peak forward voltage for instantaneous starting is 30kV and there must be no overshoot.
5. The peak inverse voltage including spike must not exceed 10kV for the first 25 microseconds after the anode pulse.
6. For single shot or burst mode applications this parameter can exceed 100kA/ μ s. The ultimate value which can be attained depends to a large extent upon the external circuit.
7. This rate of rise refers to that part of the leading edge of the pulse between 25% and 75% of the pulse amplitude.
8. Measured with respect to cathode. When grid 1 is pulse driven, the last 0.25 μ s of the top of the grid 1 pulse must overlap the corresponding first 0.25 μ s of the top of the delayed grid 2 pulse.
9. The tube may be operated with a loaded grid 2 bias voltage of 0 to -50V provided that care is taken to ensure that the peak grid 1 drive current is sufficiently low to prevent triode firing (tube control by the grid 1 pulse).
10. When d.c. priming is used on grid 1, a negative bias of 100 to 200V must be applied to grid 2 to ensure anode voltage hold-off. D.C. priming is recommended for pulse modulator and crowbar service.
11. D.C. negative bias voltages must not be applied to grid 1. When grid 1 is pulse driven, the potential of grid 1 may vary between -10 and +5V with respect to cathode potential during the period between the completion of recovery and the commencement of the succeeding grid pulse.
12. Typical figures are obtained on test using conditions of minimum grid drive. Improved performance can be expected by increasing grid drive.

13. The time interval between the instant at which the rising unloaded grid 2 pulse reaches 25% of its pulse amplitude and the instant when anode conduction takes place.
14. The drift in delay time over a period from 10 seconds to 10 minutes after reaching full voltage.

X-RAY WARNING

X-rays may be emitted by the CX1154 but the radiation is usually reduced to a safe level by the metal panels of the equipment in which the tube operates.

OUTLINE

23978

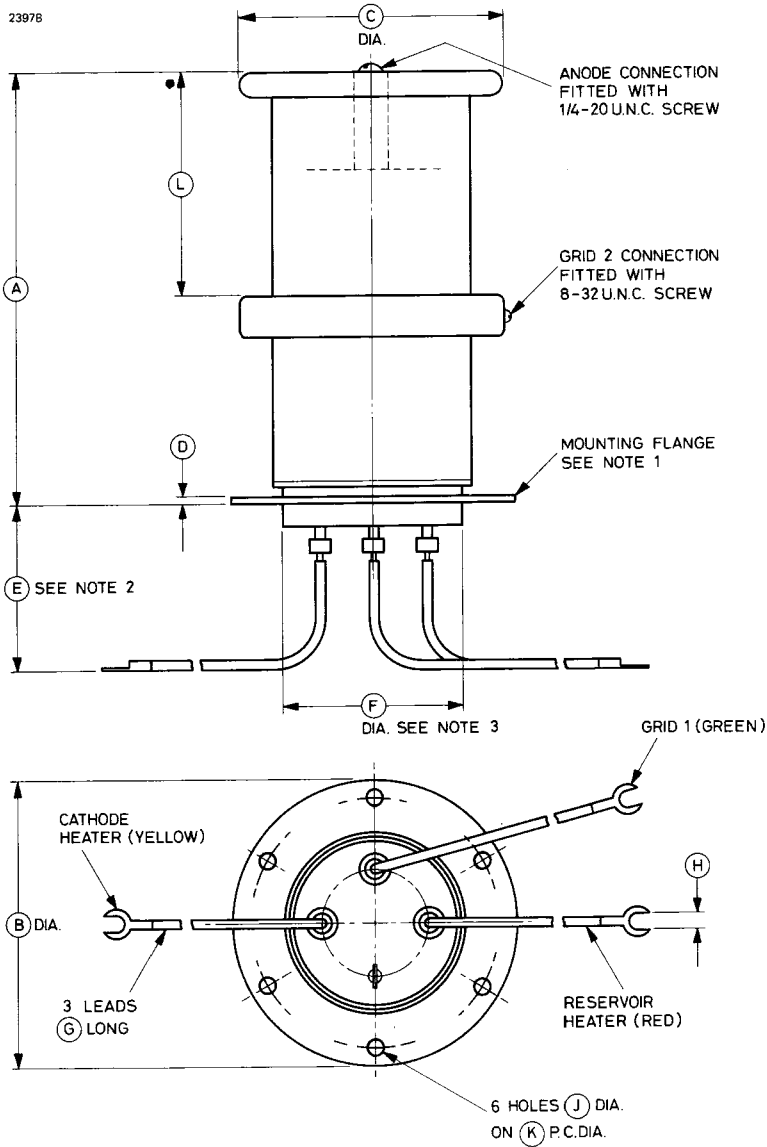

Outline Dimensions (All dimensions without limits are nominal)

Ref	Inches	Millimetres
A	6.500 max	165.1 max
B	4.375	111.1
C	4.000	101.6
D	0.100	2.54
E	2.000 min	50.80 min
F	2.750 max	69.85 max
G	6.000	152.4
H	0.250	6.35
J	0.256	6.50
K	3.750	95.25
L	3.375	85.73

Millimetre dimensions have been derived from inches except dimension J.

Outline Notes

1. The mounting flange is the connection for the cathode, cathode heater return and reservoir heater return.
2. A minimum clearance of 2.000 inches (50.80mm) must be allowed below the mounting flange.
3. The recommended mounting hole is 2.875 inches (73.03mm) diameter.

Whilst EEV has taken care to ensure the accuracy of the information contained herein it accepts no responsibility for the consequences of any use thereof and also reserves the right to change the specification of goods without notice. EEV accepts no liability beyond that set out in its standard conditions of sale in respect of infringement of third party patents arising from the use of tubes or other devices in accordance with information contained herein.



CX1154B

DOUBLE ENDED CERAMIC THYRATRON

The data to be read in conjunction with the Hydrogen Thyatron Preamble.

ABRIDGED DATA

Deuterium-filled, double ended high voltage thyatron with ceramic/metal envelope, featuring low jitter, firing time and drift. Suitable for switching high power and for switching long pulses.

Reservoirs are incorporated, operating from separate heater supplies. The tube is electrically symmetrical, with identical cathode and grid assemblies at both ends; the flange electrode which is positive when the tube is triggered is referred to as the anode.

Peak forward anode voltage	35	kV max
Peak anode current (see page 2)	3000	A max
Average anode current	3.0	A max
Anode heating factor	30×10^9	V.A.p.p.s. max
Peak output power	50	MW max

GENERAL

Electrical

Cathodes (connected internally to one end of associated heater)		oxide coated
Cathode heater voltage (each end)	$6.3 \pm 5\%$	V
Cathode heater current (each end)	21.5	A
Reservoir heater voltage (each end) (see note 1)	5.0	V
Reservoir heater current (each end)	7.0	A
Tube heating time (minimum)	15	min
Inter-electrode capacitances, 'anode' to grid 2	15 to 20	pF approx

Mechanical

Seated height (flange to flange)	9.906 inches (251.6mm) nom
Clearance required below flanges	2.000 inches (50.8mm) min
Overall diameter	4.375 inches (111.1mm) nom
Net weight	2.5kg (5.5 pounds) approx
Mounting position (see note 2)	any
Tube connections	see outline

Cooling

Forced-air	forced-air or liquid
Liquid	oil or coolant immersion
Maximum temperature of envelope	200 °C

Natural ambient cooling is usually insufficient to maintain the ceramic/metal envelope temperature below the maximum value specified above. Cooling by oil or coolant immersion is advised in view of the high voltages present. Further information is contained in the relevant section of the Preamble.

PULSE MODULATOR SERVICE (See note 4)

MAXIMUM AND MINIMUM RATINGS (Absolute values)

	Min	Max	
Anode			
Peak forward or inverse anode voltage (see note 5)	—	35	kV
Peak anode current	—	3000	A
Peak anode current (pulse repetition rate limited to 60p.p.s. max)	—	4000	A
Average anode current	—	3.0	A
Rate of rise of anode current (see notes 6 and 7)	—	5000	A/μs
Anode heating factor	—	30×10^9	V.A.p.p.s.

Grid 2

Unloaded grid 2 drive pulse voltage (see note 8)	200	1000	V
Grid 2 pulse duration	1.0	—	μs
Rate of rise of grid 2 pulse (see note 6)	1.0	—	kV/μs
Grid 2 pulse delay	0.5	3.0	μs
Peak inverse grid 2 voltage	—	450	V
Loaded grid 2 bias voltage	-50	-200	V
Forward impedance of grid 2 drive circuit	50	1000	Ω

MAXIMUM AND MINIMUM RATINGS — continued

	Min	Max	
Grid 1 — D.C. Primed (See note 9)			
D.C. grid 1 unloaded priming voltage	75	150	V
D.C. grid 1 priming current	25	50	mA

Grid 1 — Pulsed (See note 10)

Unloaded grid 1 drive pulse voltage (see note 8)	300	1000	V
Grid 1 pulse duration	2.0	—	μ s
Rate of rise of grid 1 pulse (see note 6)	1.0	—	kV/ μ s
Peak inverse grid 1 voltage	—	450	V
Loaded grid 1 bias voltage			see note 11
Peak grid 1 drive current	0.3	1.0	A

Cathode

Heater voltage	$6.3 \pm 5\%$		V
Heating time	15	—	min

Reservoir

Heater voltage (see note 1)	4.5	6.5	V
Heating time	15	—	min

Environmental

Ambient temperature	—50	+90	$^{\circ}$ C
Altitude	—	10 000	ft
	—	3	km

CHARACTERISTICS

	Min	Typical	Max	
Critical d.c. anode voltage for conduction (see note 12)	—	0.3	0.5	kV
Anode delay time (see notes 12 and 13)	—	0.1	0.25	μ s
Anode delay time drift (see notes 12 and 14)	—	15	50	ns
Time jitter (see note 12)	—	1.0	5.0	ns
Cathode heater current (at 6.3V)	18	21.5	25	A
Reservoir heater current (at 5.0V)	6.0	7.0	9.0	A

RATINGS FOR SINGLE SHOT OR CROWBAR SERVICE (See note 9)

D.C. forward anode voltage	30	kV max
Peak anode current	15 000	A max
Product of peak current and pulse duration	1.0	A.s max
Repetition frequency	1 pulse per 10s	max

NOTES

1. The reservoir heaters must be decoupled with suitable capacitors to avoid damage by spike voltages. The recommended voltage for each tube is marked on the tube, and both reservoirs must be operated at the same heater voltage.
2. The tube must be mounted by one of the cathode flanges, with flexible connections to all other electrodes.
3. An adequate flow of air must be supplied to maintain the ceramic/metal envelope temperature below the maximum rated value.
4. Triggered charging techniques are recommended because the tube has a relatively long recovery time (100–200 μ s).
5. This is the maximum hold off voltage in either direction before the tube is triggered. The maximum permissible peak forward voltage for instantaneous starting is 30kV and there must be no overshoot.
6. This rate of rise refers to that part of the leading edge of the pulse between 25% and 75% of the pulse amplitude.
7. For single shot or burst mode applications this parameter can exceed 100kA/ μ s; the ultimate value which can be attained depends upon the external circuit, but the heating factor must be reduced.
8. Measured with respect to the associated cathode. The tube is triggered by pulsing the grid 2 at the negative end, while the grid 2 at the anode (positive) end is normally connected to its associated cathode and carries most of the forward anode current. When grid 1 is pulse driven, the last 0.25 μ s of the top of the grid 1 pulse must overlap the corresponding first 0.25 μ s of the top of the delayed grid 2 pulse.
9. When d.c. priming is used on grid 1, a negative bias of 100 to 200V must be applied to grid 2 to ensure anode voltage hold-off. D.C. priming of grid 1 at both ends is recommended for crowbar service.
10. When pulse drive is applied to the triggered end of the tube, the grid 1 at the anode (positive) end will normally be d.c. primed.

11. D.C. negative bias voltages must not be applied to grid 1. When grid 1 is pulse driven, the potential of grid 1 may vary between -10 and $+5\text{V}$ with respect to cathode during the period between the completion of recovery and the start of the next grid pulse.
12. • Typical figures are obtained on test using conditions of minimum grid 2 drive. Improved performance can be expected with increased grid drive.
13. The time interval between the instant at which the rising unloaded grid 2 pulse reaches 25% of its pulse amplitude and the instant when anode conduction takes place.
14. The drift in delay time over a period from 10 seconds to 10 minutes after reaching full voltage.

X-RAY WARNING

X-rays may be emitted by the CX1154B but the radiation is usually reduced to a safe level by the metal surrounds and panels of the equipment in which the tube operates.

SCHEMATIC DIAGRAM

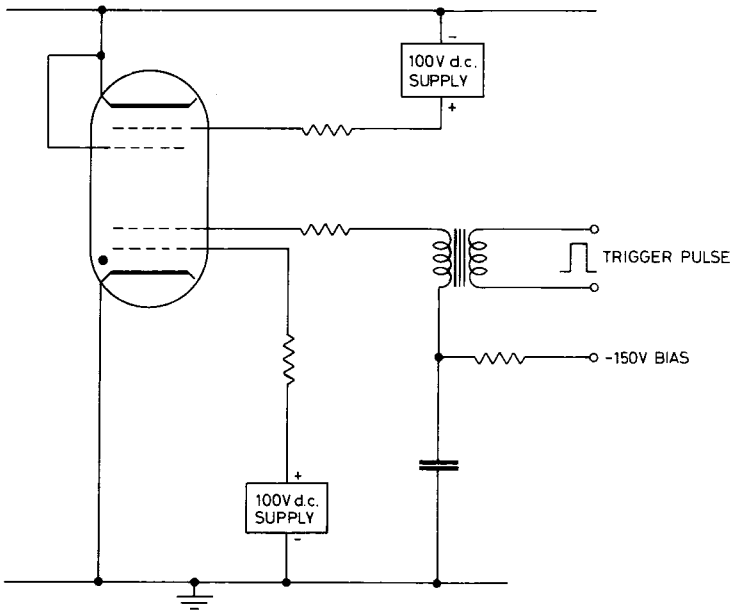

4328

OUTLINE

4326

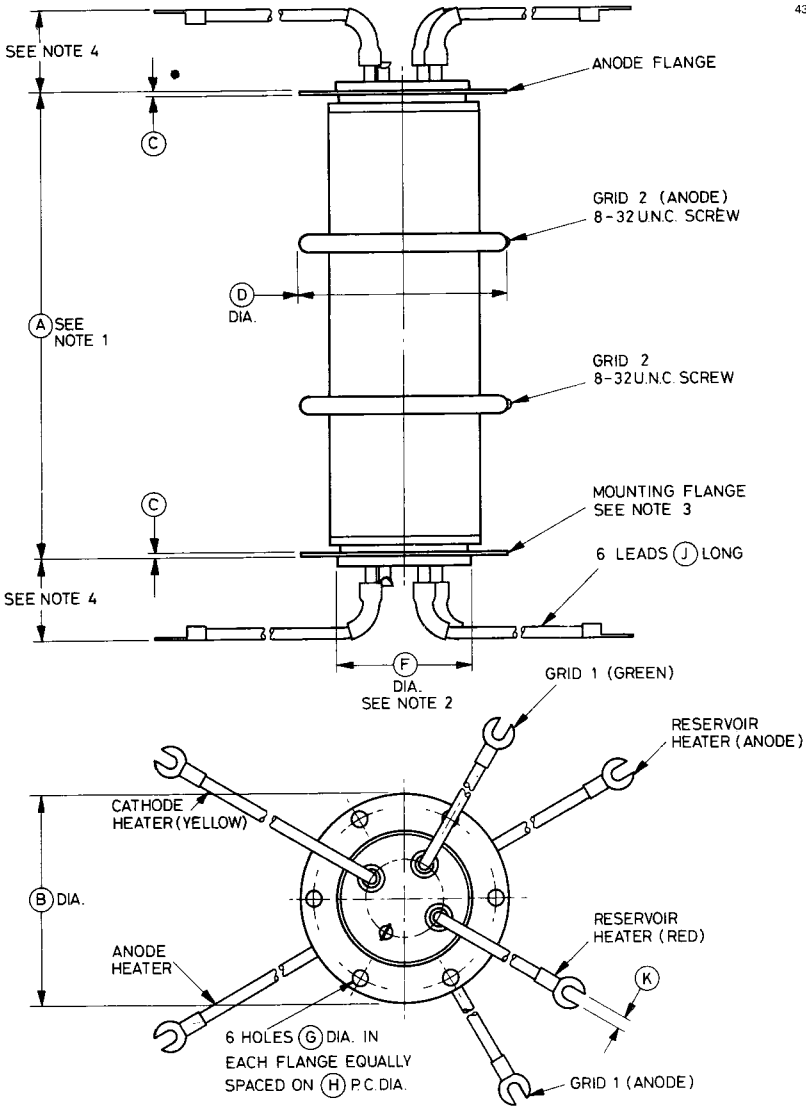

Outline Dimensions (All dimensions without limits are nominal)

Ref	Inches	Millimetres
A	9.906 ± 0.100	251.6 ± 2.54
B	4.375	111.1
C	0.100	2.54
D	4.375 ± 0.062	111.1 ± 1.6
F	2.750 max	69.85 max
G	0.256	6.50
H	3.750	95.25
J	6.000 min	152.4 min
K	0.250	6.35

Millimetre dimensions have been derived from inches.

Outline Notes

1. The two flanges will be parallel within 0.059 inch (1.5mm).
2. The recommended mounting hole is 2.875 inches (73.03mm) diameter.
3. The tube must be mounted by one flange only. The flange is the connection for the cathode, cathode heater return and reservoir heater return.
4. A minimum clearance of 2.000 inches (50.80mm) must be allowed below the flange.

Whilst EEV has taken care to ensure the accuracy of the information contained herein it accepts no responsibility for the consequences of any use thereof and also reserves the right to change the specification of goods without notice. EEV accepts no liability beyond that set out in its standard conditions of sale in respect of infringement of third party patents arising from the use of tubes or other devices in accordance with information contained herein.

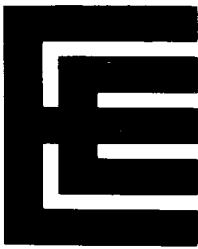

CX1157

HYDROGEN-FILLED CERAMIC THYRATRON

Service Type CV6241

The data to be read in conjunction with the Hydrogen Thyatron Preamble.

ABRIDGED DATA

Hydrogen-filled tetrode thyatron with ceramic envelope, featuring low jitter and low anode delay time drift. Suitable for use at high pulse repetition rates and in applications requiring ruggedness and compactness. A hydrogen reservoir operating from the heater supply is incorporated.

Peak forward anode voltage	20	kV max
Peak anode current	350	A max
Average anode current	500	mA max
Anode heating factor	7.0×10^9	V.A.p.p.s. max
Peak output power	3.5	MW max

GENERAL

Electrical

Cathode (connected internally to one end of heater)	oxide coated
Cathode heater voltage	$6.3 \pm 7\frac{1}{2}\%$ V
Cathode heater current	7.5 A
Reservoir heater voltage (see note 1)	$6.3 \pm 7\frac{1}{2}\%$ V
Reservoir heater current	1.5 A
Tube heating time (minimum)	3.0 min

Mechanical

Seated height	3.000 inches (76.20mm) max
Clearance required below mounting flange	1.250 inches (31.75mm) min
Overall diameter (mounting flange)	2.250 inches (57.15mm) nom
Net weight	10 ounces (284g) approx
Mounting position (see note 2)	any
Tube connections	see outline

Cooling natural, forced-air or liquid

Where natural cooling is insufficient to maintain the envelope temperatures below the specified rated values, cooling by forced-air, or by oil or coolant immersion may be used.

The temperature of the anode terminal and the base, measured at the points indicated on the outline drawing, must not exceed the values specified below.

Anode terminal	250	°C max
Base	220	°C max

PULSE MODULATOR SERVICE

MAXIMUM AND MINIMUM RATINGS (Absolute values)

	Min	Max	
Anode			
Peak forward anode voltage (see note 3)	—	20	kV
Peak inverse anode voltage (see note 4)	—	20	kV
Peak anode current	—	350	A
Average anode current	—	500	mA
Rate of rise of anode current (see notes 5 and 6)	—	2500	A/ μ s
Anode heating factor	—	7.0×10^9	V.A.p.p.s.

Grid 2

Unloaded grid 2 drive pulse voltage (see note 7)	200	750	V
Grid 2 pulse duration	1.0	—	μ s
Rate of rise of grid 2 pulse (see note 6)	1.0	—	kV/ μ s
Grid 2 pulse delay	0.5	3.0	μ s
Peak inverse grid 2 voltage	—	200	V
Loaded grid 2 bias voltage (see note 8)	-50	-200	V
Forward impedance of grid 2 drive circuit	100	1000	Ω

Grid 1 — D.C. Primed (See note 9)

D.C. grid 1 unloaded priming voltage	75	150	V
D.C. grid 1 priming current	50	150	mA

MAXIMUM AND MINIMUM RATINGS — continued

Grid 1 — Pulsed

	Min	Max	
Unloaded grid 1 drive pulse voltage (see note 7)	300	750	V
Grid 1 pulse duration	2.0	—	μ s
Rate of rise of grid 1 pulse (see note 6)	1.0	—	kV/ μ s
Peak inverse grid 1 voltage	—	200	V
Loaded grid 1 bias voltage	—	—	see note 10
Peak grid 1 drive current	0.15	0.5	A

Cathode

Heater voltage	$6.3 \pm 7\frac{1}{2}\%$	—	V
Heating time	3.0	—	min

Reservoir

Heater voltage (see note 1)	$6.3 \pm 7\frac{1}{2}\%$	—	V
Heating time	3.0	—	min

Environmental (See note 11)

Ambient temperature	—55	+130	$^{\circ}$ C
Altitude	—	10 000	ft
	—	3	km

CHARACTERISTICS

	Min	Typical	Max	
Critical d.c. anode voltage for conduction (see note 12)	—	0.2	0.3	kV
Anode delay time (see notes 12 and 13)	—	0.15	0.25	μ s
Anode delay time drift (see notes 12 and 14)	—	20	50	ns
Time jitter (see note 12)	—	1.0	5.0	ns
Recovery time	—	—	—	see note 15 and curves
Heater and reservoir current (at 6.3V)	7.5	9.0	10.5	A

SINGLE SHOT OR CROWBAR SERVICE

In applications requiring a very rapid rate of rise of anode current, the CX1157 geometry allows it to be mounted in a coaxial structure in order to minimize the total circuit inductance. Operation of the tube under the following ratings results in short anode delay times and very low time jitter.

MAXIMUM AND MINIMUM RATINGS (Absolute values)

	Min	Typical	Max	
Anode				
Peak forward anode voltage (see note 16)	—	—	20	kV
Peak anode current (see note 17)	—	—	3000	A
Average anode current	—	—	300	mA

Grid 2

Unloaded grid 2 drive pulse voltage	0.5	1.0	2.0	kV
Grid 2 pulse duration	0.25	—	5.0	μ s
Rate of rise of grid 2 pulse (unloaded)	10	30	—	kV/ μ s
Loaded grid 2 bias voltage	—50	—150	—200	V
Forward impedance of grid 2 drive circuit	50	50	500	Ω

Grid 1

Grid 1 drive current (d.c.)	50	70	100	mA
-----------------------------	----	----	-----	----

Cathode

Heater voltage	5.8	6.8	7.0	V
----------------	-----	-----	-----	---

Reservoir

Heater voltage	5.8	6.8	7.0	V
----------------	-----	-----	-----	---

CHARACTERISTICS

Anode delay time (see note 18)	—	30	75	ns
Rate of rise of anode current (see notes 18 and 19)	—	100	—	kA/ μ s
Time jitter (see note 20)	—	<1.0	2.0	ns

NOTES

1. The reservoir heater supply must be obtained either from the cathode heater supply or if a separate supply is used it must be decoupled to avoid damage to the reservoir.
2. • The tube must be mounted by means of its mounting flange.
3. The maximum permissible peak forward voltage for instantaneous starting is 16kV and there must be no overshoot.
4. The peak inverse voltage including spike must not exceed 5.0kV for the first 25 microseconds after the anode pulse.
5. For single shot or burst mode applications this parameter can exceed 100kA/ μ s. The ultimate value which can be attained depends to a large extent upon the external circuit.
6. This rate of rise refers to that part of the leading edge of the pulse between 25% and 75% of the pulse amplitude.
7. Measured with respect to cathode. When grid 1 is pulse driven, the last 0.25 μ s of the top of the grid 1 pulse must overlap the corresponding first 0.25 μ s of the top of the delayed grid 2 pulse.
8. The tube may be operated with a loaded grid 2 bias voltage of 0 to -50V provided that care is taken to ensure that the peak grid 1 drive current is sufficiently low to prevent triode firing (tube control by the grid 1 pulse).
9. When d.c. priming is used on grid 1, a negative bias of 100 to 200V must be applied to grid 2 to ensure anode voltage hold-off. D.C. priming is especially suitable in crowbar service.
10. D.C. negative bias voltages must not be applied to grid 1. When grid 1 is pulse driven, the potential of grid 1 may vary between -10 and +5V with respect to cathode potential during the period between the completion of recovery and the commencement of the succeeding grid pulse.
11. To ensure a high standard of ruggedness, all tubes are subjected to the following tests. After each mechanical test all the tubes must then satisfy all electrical tests.
 - (a) Vibration — The tubes are vibrated at 50Hz with acceleration of 10g for one minute in the direction of the cathode axis and then in one direction perpendicular to the cathode axis. See note 2.
 - (b) Recovery Time — The tubes are tested for recovery at zero grid 2 bias voltage with a maximum limit of 35 μ s.

The tubes are subjected to the following tests on a sampling basis.

- (c) Operation under Vibration — The tubes are vibrated at 10g in each of three planes at a sweep rate of one octave per minute from 20 to 500 Hz, under normal operating conditions. See note 2.
 - (d) Survival under Vibration and Heater Cycling — The tubes are vibrated at 10g at a sweep rate of one octave per minute from 5 to 500 Hz for 70 hours in each plane together with heater cycling of a 10 minute on/off cycle. See note 2.
 - (e) Long Duration Shock — The tubes are tested at 125g for ten milliseconds with two blows in each plane. See note 2.
 - (f) High Temperature Test — The tubes are tested at a base temperature of 220°C and an anode temperature of 250°C under normal operating conditions for 5 hours. This implies an ambient temperature of 130°C.
 - (g) Low Temperature Instant Start — The tubes are cooled to -20°C and subjected to a 3-minute warm up period with 5.8V on the heater. The tubes must withstand a snap start at 10kV and operate satisfactorily.
 - (h) Standby-Life — The tubes are run with 6.3V heater voltage applied for 500 hours.
12. Typical figures are obtained on test using conditions of minimum grid drive. Improved performance can be expected by increasing grid drive.
 13. The time interval between the instant when the unloaded grid 2 voltage passes cathode potential and the instant when anode conduction takes place.
 14. The drift in delay time over a period from 10 seconds to 10 minutes after reaching full voltage.
 15. The recovery characteristics are controlled on a sampling basis.
 16. For crowbar applications where the tube is required to hold off d.c. anode voltage for longer than 20ms, the maximum peak forward anode voltage is 16kV. If the reservoir voltage is increased above normal, the d.c. hold-off voltage may be reduced.
 17. For pulse durations not exceeding 0.25μs.

18. Shorter anode delay time and higher rate of rise of anode current may be obtained by increasing the cathode and reservoir heater voltages from 6.3 to 6.8V.
19. The rate of rise of anode current obtainable is also dependent on the
 - total circuit inductance and transmission line type matching.
20. With the grid drive conditions specified, the anode delay time jitter will normally be less than 1.0ns.

X-RAY WARNING

X-rays may be emitted by the CX1157 but the radiation is usually reduced to a safe level by the metal panels of the equipment in which the tube operates.

MAXIMUM RECOVERY CHARACTERISTICS

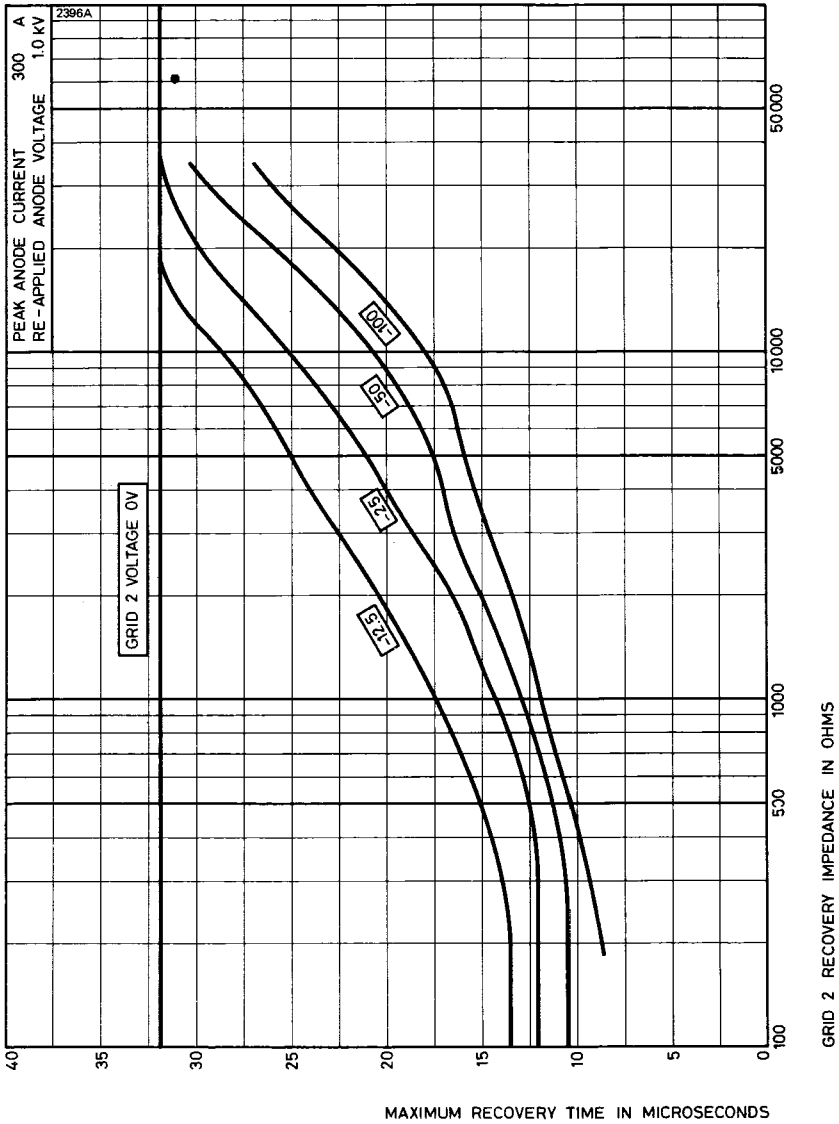

OUTLINE

23958

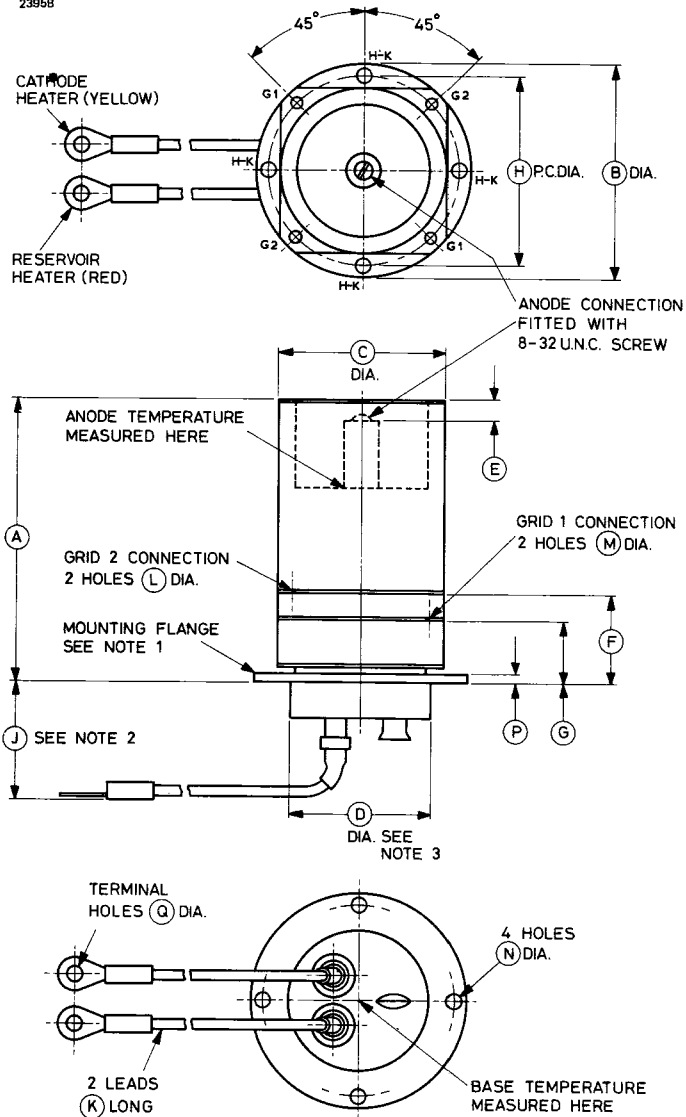

Outline Dimensions (All dimensions without limits are nominal)

Ref	Inches	Millimetres
A	3.000 max	76.20 max
B	2.250	57.15
C	1.750 \pm 0.031	44.45 \pm 0.79
D	1.437	36.50
E	0.220 \pm 0.015	5.59 \pm 0.38
F	0.940	23.88
G	0.658	16.71
H	2.031 \pm 0.010	51.59 \pm 0.25
J	1.250 min	31.75 min
K	6.000	152.4
L	0.120	3.05
M	0.120	3.05
N	0.165	4.19
P	0.100	2.54
Q	0.165	4.19

Millimetre dimensions have been derived from inches.

Outline Notes

1. The mounting flange is the connection for the cathode, cathode heater return and reservoir heater return.
2. A minimum clearance of 1.250 inches (31.75mm) must be allowed below the flange.
3. The recommended mounting hole is 1.500 inches (38.10mm) diameter.

Whilst EEV has taken care to ensure the accuracy of the information contained herein it accepts no responsibility for the consequences of any use thereof and also reserves the right to change the specification of goods without notice. EEV accepts no liability beyond that set out in its standard conditions of sale in respect of infringement of third party patents arising from the use of tubes or other devices in accordance with information contained herein.

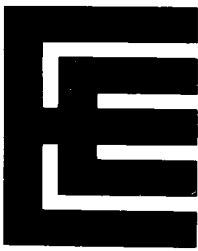

DEUTERIUM THYRATRON

Service Type CV9080

The data to be read in conjunction with the Hydrogen Thyatron Preamble.

ABRIDGED DATA

Deuterium-filled tetrode thyatron, featuring low jitter and low anode delay time drift. Suitable for use at high pulse repetition rates, in parallel for switching higher powers, or for switching long pulses. A reservoir operating from the cathode heater supply is incorporated.

Peak forward anode voltage	33	kV max
Peak anode current (see page 2)	1000	A max
Average anode current	1.25	A max
Anode heating factor	14×10^9	V.A.p.p.s. max
Peak output power	16.5	MW max

GENERAL

Electrical

Cathode (connected internally to mid-point of heater)	oxide coated
Heater voltage	$6.3 \pm 5\%$ V
Heater current	22 A
Tube heating time (minimum)	5.0 min
Inter-electrode capacitances (approximate):	
anode to grid 2 (grid 1 and cathode not connected)	13 pF
anode to grid 1 (grid 2 and cathode not connected)	7.5 pF
anode to cathode (grid 1 and grid 2 not connected)	26 pF

Mechanical

Overall length	12.500 inches (317.5mm) max
Overall diameter	3.312 inches (84.12mm) max
Net weight	1½ pounds (0.7kg) approx
Mounting position (see note 1)	any
Base	pin spacing as B5F; metal shell with micalex insert
Base adaptors	see page 5
Top cap (see note 2)	B.S.448-CT3

Cooling	natural
-------------------	---------

PULSE MODULATOR SERVICE

MAXIMUM AND MINIMUM RATINGS (Absolute values)

	Min	Max	
Anode			
Peak forward anode voltage (see note 3)	—	33	kV
Peak inverse anode voltage (see note 4)	—	25	kV
Peak anode current	—	1000	A
Peak anode current (pulse repetition rate limited to 60p.p.s. max)	—	2000	A
Average anode current (see note 14)	—	1.25	A
Rate of rise of anode current (see note 5)	—	5000	A/ μ s
Anode heating factor	—	14×10^9	V.A.p.p.s.
Grid 2			
Unloaded grid 2 drive pulse voltage (see note 6)	200	1000	V
Grid 2 pulse duration	1.0	—	μ s
Rate of rise of grid 2 pulse (see note 5)	1.0	—	kV/ μ s
Grid 2 pulse delay	0.5	3.0	μ s
Peak inverse grid 2 voltage	—	450	V
Loaded grid 2 bias voltage	-50	-150	V
Forward impedance of grid 2 drive circuit	50	800	Ω
Grid 1 — D.C. Primed (See note 7)			
D.C. grid 1 unloaded priming voltage	75	150	V
D.C. grid 1 priming current	50	100	mA
Grid 1 — Pulsed			
Unloaded grid 1 drive pulse voltage (see note 6)	300	1000	V
Grid 1 pulse duration	2.0	—	μ s
Rate of rise of grid 1 pulse (see note 5)	1.0	—	kV/ μ s
Peak inverse grid 1 voltage	—	450	V
Loaded grid 1 bias voltage	—	—	see note 8
Peak grid 1 drive current	0.3	1.0	A
Cathode			
Heater voltage	—	$6.3 \pm 5\%$	V
Tube heating time	5.0	—	min
Environmental			
Ambient temperature	-50	+90	$^{\circ}$ C
Altitude	—	10 000	ft
	—	3	km

CHARACTERISTICS

	Min	Typical	Max	
Critical d.c. anode voltage for conduction (see note 9)	—	0.5	2.0	kV
Anode delay time (see notes 9 and 10)	—	0.15	0.25	μ s
Anode delay time drift (see notes 9, 11 and 12)	—	20	50	ns
Time jitter (see notes 9 and 12)	—	1.0	5.0	ns
Recovery time				see note 13 and curves
Heater current (at 6.3V)	18	22	25	A

RATINGS FOR SINGLE SHOT OR CROWBAR SERVICE (See note 7)

D.C. forward anode voltage	30	kV max
Peak anode current	15 000	A max
Product of peak current and pulse length	0.6	A.s max
Repetition frequency	1 pulse per 10s	max

NOTES

1. Clamping is only permissible by the base.
2. A large area anode connector EEV type MA360 is recommended.
3. The maximum permissible peak forward voltage for instantaneous starting is 20kV and there must be no overshoot.
4. The peak inverse voltage must not exceed 10kV for the first 25 microseconds after the anode pulse.
5. This rate of rise refers to that part of the leading edge of the pulse between 25% and 75% of the pulse amplitude.
6. Measured with respect to cathode. In certain cases the maximum drive pulse voltage may be exceeded without damage to the tube; a maximum value of 2.5kV is then recommended. When grid 1 is pulse driven, the last 0.25 μ s of the top of the grid 1 pulse must overlap the corresponding first 0.25 μ s of the top of the delayed grid 2 pulse.

7. When d.c. priming is used on grid 1, a negative bias of 100 to 200V must be applied to grid 2 to ensure anode voltage hold-off. D.C. priming is recommended for crowbar service.
8. D.C. negative bias voltages must not be applied to grid 1. When grid 1 is pulse driven, the potential of grid 1 may vary between -10 and $+5$ V with respect to cathode potential during the period between the completion of recovery and the commencement of the succeeding grid pulse.
9. Typical figures are obtained on test using conditions of minimum grid drive. Improved performance can be expected by increasing the grid drive.
10. The time interval between the instant at which the rising unloaded grid 2 pulse reaches 25% of its pulse amplitude and the instant when anode conduction takes place.
11. The drift in delay time over a period from 10 seconds to 10 minutes after reaching full voltage.
12. For equipment where jitter and anode delay time drift are not important, the tube may be triggered by applying a single pulse to grid 2 and connecting grid 1 to grid 2 via a 100pF capacitor shunted by a $10M\Omega$ resistor. These components are incorporated in adaptor assemblies MA92 and MA179 (see page 5).
13. The recovery characteristics are controlled on a sampling basis.
14. For inverter type applications where the peak current does not exceed 50A, the maximum average anode current may be increased to 2.5A; EEV should be consulted.

X-RAY WARNING

X-rays are emitted by the CX1159 from the region of the anode, but the radiation is usually reduced to a safe level by the steel panels of the equipment in which the tube operates.

ADAPTOR ASSEMBLIES

In addition to standard top cap connectors and base sockets, a number of adaptor assemblies are available from English Electric Valve Company Ltd.

MA91

A five-contact socket fitted with flexible leads and terminal tags, and mounted on an insulating base plate. It provides a conversion from base to flange type mounting.

MA92

Similar to MA91 but incorporates an RC network and is designed for use with CX1159 where a single pulse drive and flying lead connections are required.

MA179

A five-contact socket with flexible leads and terminal tags, mounted on an insulating base plate; it is fitted with a base clamp. It incorporates an RC network and is designed for use with CX1159 where a single pulse drive and flying lead connections are required.

Further information is contained in the leaflet 'Accessories for Hydrogen Thyratrons'.

MAXIMUM RECOVERY CHARACTERISTICS

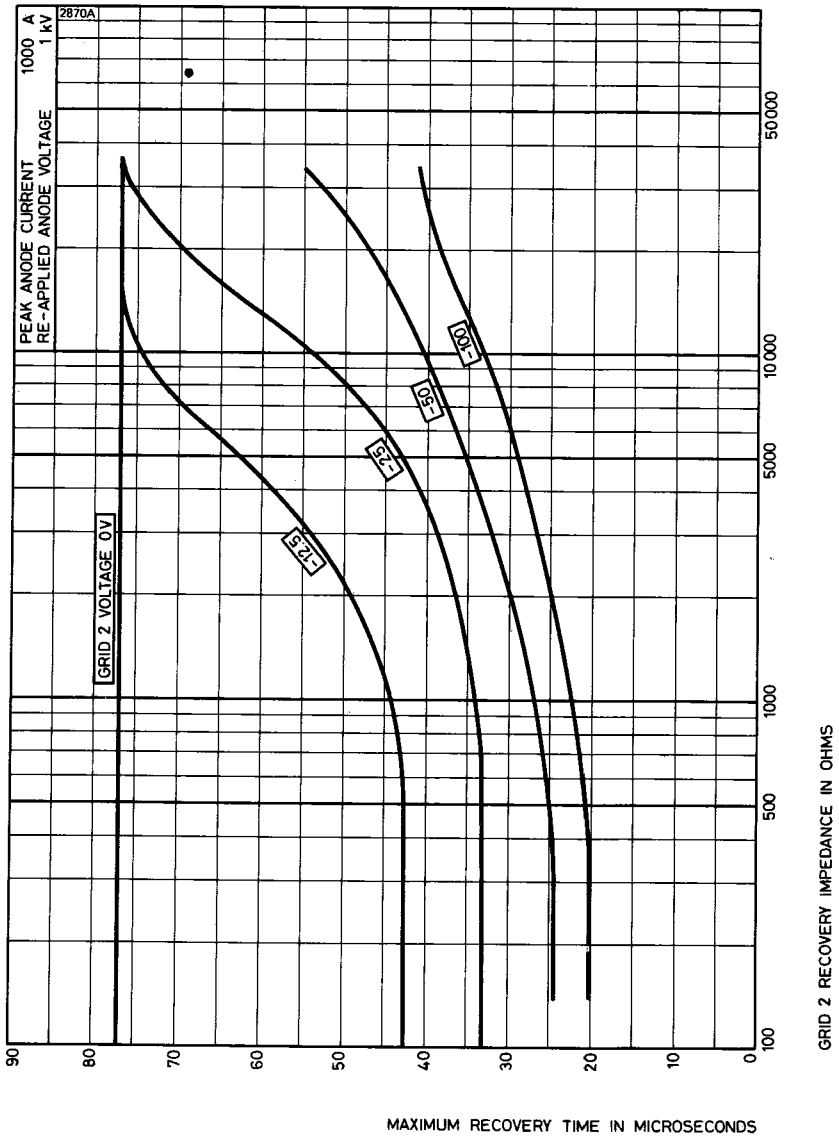

Whilst EEV has taken care to ensure the accuracy of the information contained herein it accepts no responsibility for the consequences of any use thereof and also reserves the right to change the specification of goods without notice. EEV accepts no liability beyond that set out in its standard conditions of sale in respect of infringement of third party patents arising from the use of tubes or other devices in accordance with information contained herein.

OUTLINE (All dimensions without limits are nominal)

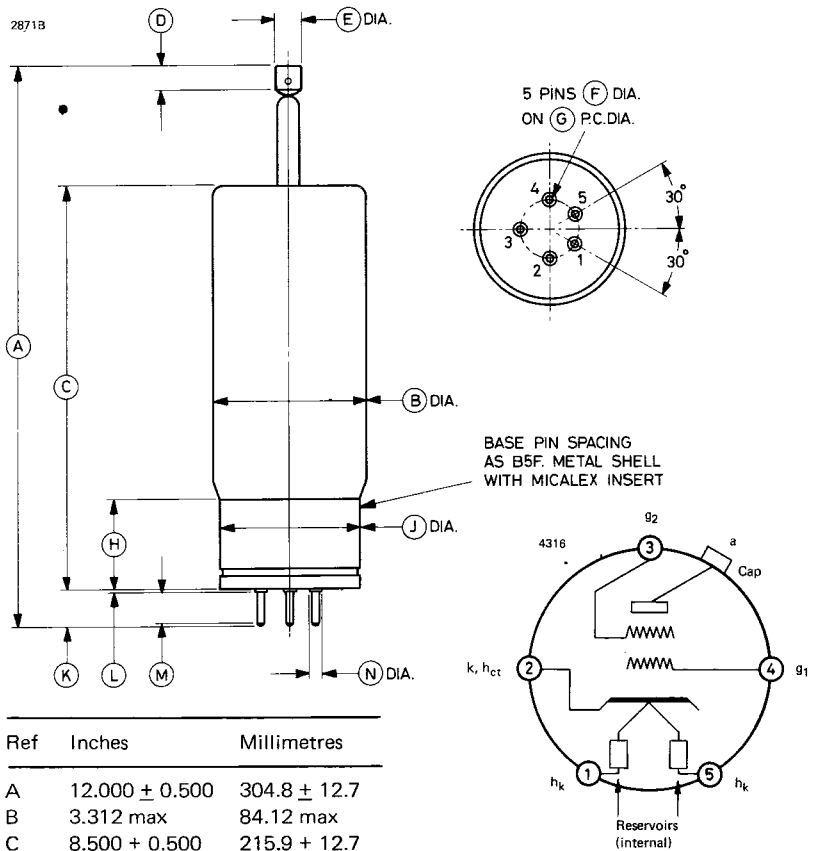

Ref	Inches	Millimetres
A	12.000 ± 0.500	304.8 ± 12.7
B	3.312 max	84.12 max
C	8.500 ± 0.500	215.9 ± 12.7
D	0.500 min	12.70 min
E	0.566 ± 0.007	14.38 ± 0.18
F	0.187 ± 0.003	4.750 ± 0.076
G	1.250	31.75
H	1.937	49.20
J	3.062 ± 0.062	77.77 ± 1.57
K	0.770 max	19.56 max
L	0.073 max	1.85 max
M	0.575 min	14.60 min
N	0.260 max	6.60 max

Millimetre dimensions have been derived from inches.

Pin	Element
1	Heater
2	Cathode, connected internally to heater mid-point
3	Grid 2
4	Grid 1
5	Heater
Top cap	Anode



HYDROGEN-FILLED CERAMIC THYRATRON

The data to be read in conjunction with the Hydrogen Thyatron Preamble.

ABRIDGED DATA

Hydrogen-filled tetrode thyatron with ceramic envelope, featuring low jitter and low anode delay time drift. Suitable for use at high pulse repetition rates and in applications requiring ruggedness and compactness. A hydrogen reservoir operating from the heater supply is incorporated.

The CX1164 is particularly recommended for circuits where a high rate of rise of anode current is required.

Peak forward anode voltage	12	kV max
Peak anode current	350	A max
Average anode current	500	mA max
Anode heating factor	7.0×10^9	V.A.p.p.s. max
Peak output power	2.1	MW max

GENERAL

Electrical

Cathode (connected internally to one end of heater)	oxide coated
Cathode heater voltage	$6.3 \pm 7\frac{1}{2}\%$ V
Cathode heater current	7.5 A
Reservoir heater voltage (see note 1)	$6.3 \pm 7\frac{1}{2}\%$ V
Reservoir heater current	1.5 A
Tube heating time (minimum)	3.0 min

Mechanical

Seated height	3.000 inches (76.20mm) max
Clearance required below mounting flange	1.250 inches (31.75mm) min
Overall diameter (mounting flange)	2.250 inches (57.15mm) nom
Net weight	10 ounces (284g) approx
Mounting position (see note 2)	any
Tube connections	see outline

Cooling natural, forced-air or liquid

Where natural cooling is insufficient to maintain the envelope temperatures below the specified rated values, cooling by forced-air, or by oil or coolant immersion may be used.

The temperature of the anode terminal and the base, measured at the points indicated on the outline drawing, must not exceed the values specified below.

Anode terminal	250	°C max
Base	220	°C max

PULSE MODULATOR SERVICE

MAXIMUM AND MINIMUM RATINGS (Absolute values)

	Min	Max	
Anode			
Peak forward anode voltage (see note 3)	—	12	kV
Peak inverse anode voltage (see note 4)	—	12	kV
Peak anode current	—	350	A
Average anode current	—	500	mA
Rate of rise of anode current (see notes 5 and 6)	—	10 000	A/ μ s
Anode heating factor	—	7.0×10^9	V.A.p.p.s.

Grid 2

Unloaded grid 2 drive pulse voltage (see note 7)	200	750	V
Grid 2 pulse duration	1.0	—	μ s
Rate of rise of grid 2 pulse (see note 6)	1.0	—	kV/ μ s
Grid 2 pulse delay	0.5	3.0	μ s
Peak inverse grid 2 voltage	—	200	V
Loaded grid 2 bias voltage (see note 8)	-50	-200	V
Forward impedance of grid 2 drive circuit	100	1000	Ω

Grid 1 — D.C. Primed (See note 9)

D.C. grid 1 unloaded priming voltage	75	150	V
D.C. grid 1 priming current	50	150	mA

MAXIMUM AND MINIMUM RATINGS — Continued

	Min	Max	
Grid 1 — Pulsed			
Unloaded grid 1 drive pulse voltage (see note 7)	300	750	V
Grid 1 pulse duration	2.0	—	μ s
Rate of rise of grid 1 pulse (see note 6)	1.0	—	kV/ μ s
Peak inverse grid 1 voltage	—	200	V
Loaded grid 1 bias voltage	see note 10		
Peak grid 1 drive current	0.15	0.5	A
Cathode			
Heater voltage	6.3 \pm 7½%		V
Heating time	3.0	—	min
Reservoir			
Heater voltage (see note 1)	6.3 \pm 7½%		V
Heating time	3.0	—	min
Environmental (See note 11)			
Ambient temperature	—55	+130	°C
Altitude	—	10 000	ft
	—	3	km

CHARACTERISTICS

	Min	Typical	Max	
Critical d.c. anode voltage for conduction (see note 12)	—	0.2	0.3	kV
Anode delay time (see notes 12 and 13)	—	0.15	0.25	μ s
Anode delay time drift (see notes 12 and 14)	—	20	50	ns
Time jitter (see note 12)	—	1.0	5.0	ns
Recovery time	see note 15			
Heater and reservoir current (at 6.3V)	7.5	9.0	10.5	A

NOTES

1. The reservoir heater supply must be obtained either from the cathode heater supply or if a separate supply is used it must be decoupled to avoid damage to the reservoir.
2. The tube must be mounted by means of its mounting flange.
3. The maximum permissible peak forward voltage for instantaneous starting is 7.0kV and there must be no overshoot.
4. The peak inverse voltage including spike must not exceed 5.0kV for the first 25 microseconds after the anode pulse.
5. For single shot or burst mode applications this parameter can exceed 100kA/ μ s. The ultimate value which can be attained depends to a large extent upon the external circuit.
6. This rate of rise refers to that part of the leading edge of the pulse between 25% and 75% of the pulse amplitude.
7. Measured with respect to cathode. When grid 1 is pulse driven, the last 0.25 μ s of the top of the grid 1 pulse must overlap the corresponding first 0.25 μ s of the top of the delayed grid 2 pulse.
8. The tube may be operated with a loaded grid 2 bias voltage of 0 to -50V provided that care is taken to ensure that the peak grid 1 drive current is sufficiently low to prevent triode firing (tube control by the grid 1 pulse).
9. When d.c. priming is used on grid 1, a negative bias of 100 to 200V must be applied to grid 2 to ensure anode voltage hold-off.
10. D.C. negative bias voltages must not be applied to grid 1. When grid 1 is pulse driven, the potential of grid 1 may vary between -10 and +5V with respect to cathode potential during the period between the completion of recovery and the commencement of the succeeding grid pulse.
11. To ensure a high standard of ruggedness, all tubes are subjected to the following tests. After each mechanical test all the tubes must then satisfy all electrical tests.
 - (a) Vibration — The tubes are vibrated at 50Hz with acceleration of 10g for one minute in the direction of the cathode axis and then in one direction perpendicular to the cathode axis. See note 2.
 - (b) Recovery Time — The tubes are tested for recovery at zero grid 2 bias voltage with a maximum limit of 35 μ s.

The tubes are subjected to the following tests on a sampling basis.

- (c) Operation under Vibration – The tubes are vibrated at 10g in each of three planes at a sweep rate of one octave per minute from 20 to 500 to 20Hz, under normal operating conditions. See note 2.
 - (d) Survival under Vibration and Heater Cycling – The tubes are vibrated at 10g at a sweep rate of one octave per minute from 5 to 500Hz for 70 hours in each plane together with heater cycling of a 10 minute on/off cycle. See note 2.
 - (e) Long Duration Shock – The tubes are tested at 125g for ten milliseconds with two blows in each plane. See note 2.
 - (f) High Temperature Test – The tubes are tested at a base temperature of 220°C and an anode temperature of 250°C under normal operating conditions for 5 hours. This implies an ambient temperature of 130°C.
 - (g) Low Temperature Instant Start – The tubes are cooled to –20°C and subjected to a 3-minute warm up period with 5.8V on the heater. The tubes must withstand a snap start at 10kV and operate satisfactorily.
 - (h) Standby-Life – The tubes are run with 6.3V heater voltage applied for 500 hours.
12. Typical figures are obtained on test using conditions of minimum grid drive. Improved performance can be expected by increasing grid drive.
 13. The time interval between the instant when the unloaded grid 2 voltage passes cathode potential and the instant when anode conduction takes place.
 14. The drift in delay time over a period from 10 seconds to 10 minutes after reaching full voltage.
 15. The recovery characteristics are controlled on a sampling basis.

X-RAY WARNING

X-rays may be emitted by the CX1164 but the radiation is usually reduced to a safe level by the steel panels of the equipment in which the tube operates.

OUTLINE

23958

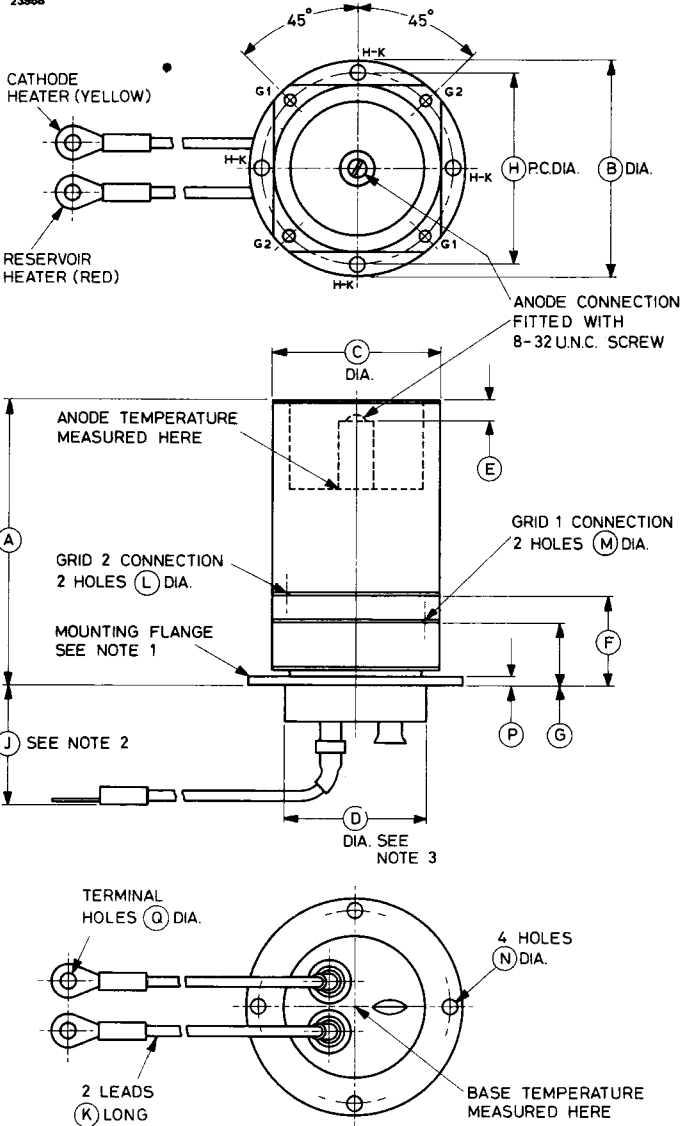

Outline Dimensions (All dimensions without limits are nominal)

Ref	Inches	Millimetres
A	3.000 max	76.20 max
B	2.250	57.15
C	1.750 ± 0.031	44.45 ± 0.79
D	1.437	36.50
E	0.220 ± 0.015	5.59 ± 0.38
F	0.940	23.88
G	0.658	16.71
H	2.050 ± 0.020	52.07 ± 0.51
J	1.250 min	31.75 min
K	6.000	152.4
L	0.120	3.05
M	0.120	3.05
N	0.165	4.19
P	0.100	2.54
Q	0.165	4.19

Millimetre dimensions have been derived from inches.

Outline Notes

1. The mounting flange is the connection for the cathode, cathode heater return and reservoir heater return.
2. A minimum clearance of 1.250 inches (31.75mm) must be allowed below the flange.
3. The recommended mounting hole is 1.500 inches (38.10mm) diameter.

Whilst EEV has taken care to ensure the accuracy of the information contained herein it accepts no responsibility for the consequences of any use thereof and also reserves the right to change the specification of goods without notice. EEV accepts no liability beyond that set out in its standard conditions of sale in respect of infringement of third party patents arising from the use of tubes or other devices in accordance with information contained herein.

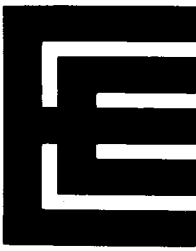

TWO-GAP CERAMIC THYRATRON

The data to be read in conjunction with the Hydrogen Thyatron Preamble.

ABRIDGED DATA

Deuterium-filled, two-gap, high voltage thyatron with ceramic/metal envelope, featuring low jitter, firing time and drift. Suitable for switching high power at high pulse repetition rates or for switching long pulses. A reservoir operating from a separate heater supply is incorporated.

Peak forward anode voltage	80	kV max
Peak anode current (see page 2)	3000	A max
Average anode current	3.0	A max
Anode heating factor	70×10^9	V.A.p.p.s. max
Peak output power	100	MW max

GENERAL

Electrical

Cathode (connected internally to one end of heater)	oxide coated
Cathode heater voltage	$6.3 \pm 5\%$ V
Cathode heater current	21.5 A
Reservoir heater voltage (see note 1)	5.0 V
Reservoir heater current	7.0 A
Tube heating time (minimum)	15 min
Inter-electrode capacitances (approximate):	
anode to gradient grid	15 to 20 pF
gradient grid to grid 2	15 to 20 pF

Mechanical

Seated height	10.00 inches (254mm) max
Clearance required below mounting flange	2.000 inches (50.8mm) min
Overall diameter (mounting flange)	4.375 inches (111.1mm) nom
Net weight	6½ pounds (3kg) approx
Mounting position (see note 2)	any
Tube connections	see outline

Cooling	forced-air or liquid
Forced-air	see note 3
Liquid	oil or coolant immersion
Maximum temperature of envelope	200 °C

Natural ambient cooling is usually insufficient to maintain the ceramic/metal envelope temperature below the maximum value specified above. Cooling by oil or coolant immersion is advised in view of the high voltages present. Further information is contained in the relevant section of the Preamble.

PULSE MODULATOR SERVICE

MAXIMUM AND MINIMUM RATINGS (Absolute values)

	Min	Max	
Anode			
Peak forward anode voltage (see note 4)	—	80	kV
Peak inverse anode voltage (see note 5)	—	80	kV
Peak anode current	—	3000	A
Peak anode current (pulse repetition rate limited to 60p.p.s. max)	—	4000	A
Average anode current	—	3.0	A
Rate of rise of anode current (see notes 6 and 7)	—	5000	A/ μ s
Anode heating factor	—	70×10^9	V.A.p.p.s.

Grid 2

Unloaded grid 2 drive pulse voltage (see note 8)	200	1000	V
Grid 2 pulse duration	1.0	—	μ s
Rate of rise of grid 2 pulse (see note 7)	1.0	—	kV/ μ s
Grid 2 pulse delay	0.5	3.0	μ s
Peak inverse grid 2 voltage	—	450	V
Loaded grid 2 bias voltage (see note 9)	—50	—200	V
Forward impedance of grid 2 drive circuit	50	1000	Ω

Grid 1 – D.C. Primed (See note 10)

D.C. grid 1 unloaded priming voltage	75	150	V
D.C. grid 1 priming current	75	150	mA

MAXIMUM AND MINIMUM RATINGS – continued

Grid 1 – Pulsed

	Min	Max	
Unloaded grid 1 drive pulse voltage (see note 8)	300	1000	V
Grid 1 pulse duration	2.0	—	μ s
Rate of rise of grid 1 pulse (see note 7)	1.0	—	kV/ μ s
Peak inverse grid 1 voltage	—	450	V
Loaded grid 1 bias voltage	—	—	see note 11
Peak grid 1 drive current	0.3	1.0	A

Cathode

Heater voltage	$6.3 \pm 5\%$	—	V
Heating time	15	—	min

Reservoir

Heater voltage (see note 1)	4.5	6.5	V
Heating time	15	—	min

Environmental

Ambient temperature	–50	+90	$^{\circ}$ C
Altitude	—	10 000	ft
	—	3	km

CHARACTERISTICS

	Min	Typical	Max	
Critical d.c. anode voltage for conduction (see note 12)	—	3.0	5.0	kV
Anode delay time (see notes 12 and 13)	—	0.1	0.25	μ s
Anode delay time drift (see notes 12 and 14)	—	15	50	ns
Time jitter (see note 12)	—	1.0	5.0	ns
Cathode heater current (at 6.3V)	18	21.5	25	A
Reservoir heater current (at 5.0V)	6.0	7.0	9.0	A

RATINGS FOR SINGLE SHOT OR CROWBAR SERVICE (See note 10)

D.C. forward anode voltage	70	kV max
Peak anode current	15 000	A max
Product of peak current and pulse length	0.1	A.s max
Repetition frequency	1 pulse per 10s	max

NOTES

1. The reservoir heater must be decoupled with a suitable capacitor to avoid damage by spike voltages. The recommended reservoir heater voltage is stamped on individual tube envelopes.
2. The tube must be mounted by means of its mounting flange.
3. An adequate flow of air must be supplied to maintain the ceramic/metal envelope temperature below the maximum rated value.
4. The maximum permissible peak forward voltage for instantaneous starting is 40kV and there must be no overshoot.
5. The peak inverse voltage including spike must not exceed 20kV for the first 125 microseconds after the anode pulse.
6. For single shot or burst mode applications this parameter can exceed 100kA/ μ s. The ultimate value which can be attained depends to a large extent upon the external circuit.
7. This rate of rise refers to that part of the leading edge of the pulse between 25% and 75% of the pulse amplitude.
8. Measured with respect to cathode. When grid 1 is pulse driven, the last 0.25 μ s of the top of the grid 1 pulse must overlap the corresponding first 0.25 μ s of the top of the delayed grid 2 pulse.
9. The tube may be operated with a loaded grid 2 bias voltage of 0 to -50V provided that care is taken to ensure that the peak grid 1 drive current is sufficiently low to prevent triode firing (tube control by the grid 1 pulse).
10. When d.c. priming is used on grid 1, a negative bias of 100 to 200V must be applied to grid 2 to ensure anode voltage hold-off. D.C. priming is recommended for pulse modulator and crowbar service.
11. D.C. negative bias voltages must not be applied to grid 1. When grid 1 is pulse driven, the potential of grid 1 may vary between -10 and +5V with respect to cathode potential during the period between the completion of recovery and the commencement of the succeeding grid pulse.
12. Typical figures are obtained on test using conditions of minimum grid drive. Improved performance can be expected by increasing grid drive.

13. The time interval between the instant at which the rising unloaded grid 2 pulse reaches 25% of its pulse amplitude and the instant when anode conduction takes place.
14. The drift in delay time over a period from 10 seconds to 10 minutes
 - after reaching full voltage.

X-RAY WARNING

X-rays may be emitted by the CX1168 but the radiation is usually reduced to a safe level by the metal panels of the equipment in which the tube operates.

SCHEMATIC DIAGRAM

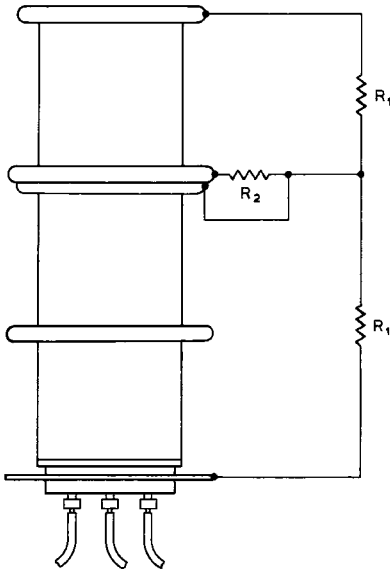

Recommended Values

$$R_1 = 10 \text{ to } 20M\Omega$$

$$R_2 = 470 \text{ to } 1000\Omega$$

Please consult EEV for alternative methods of connection.

OUTLINE

23988

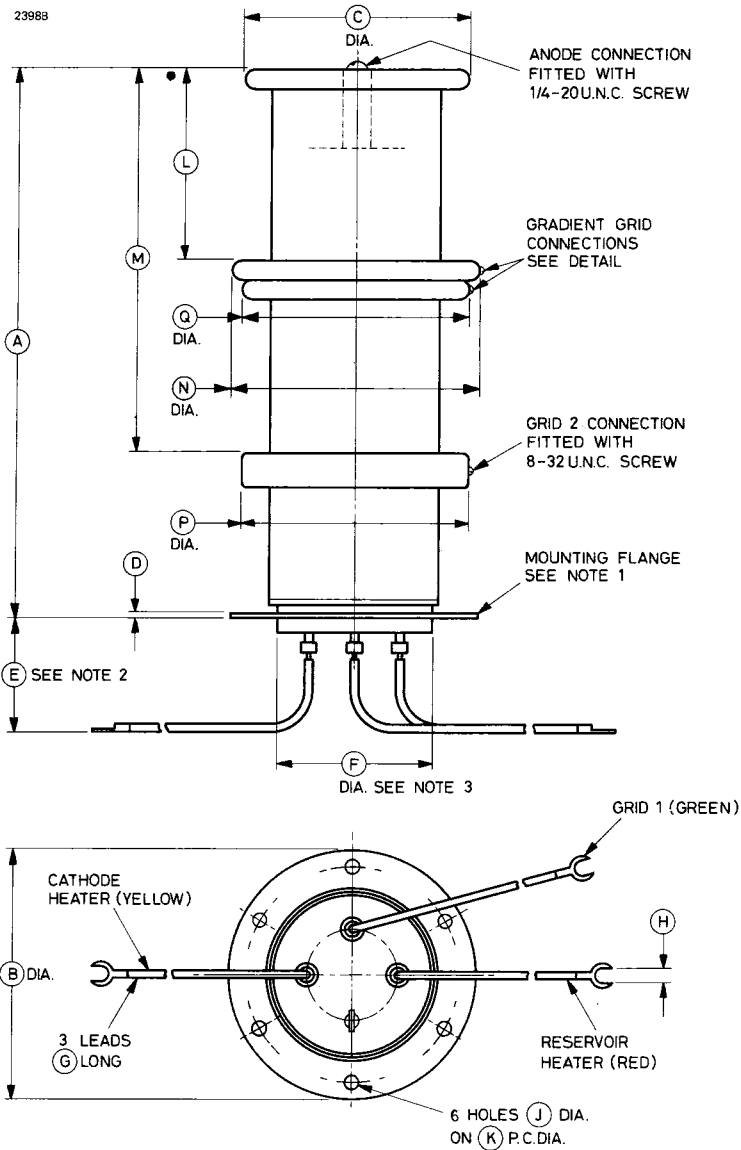

Detail of Gradient Grid Connections

3573A

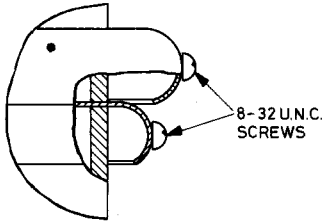

Outline Dimensions (All dimensions without limits are nominal)

Ref	Inches	Millimetres	Ref	Inches	Millimetres
A	10.000 max	254.0 max	J	0.256	6.50
B	4.375	111.1	K	3.750	95.25
C	4.000	101.6	L	3.375	85.73
D	0.100	2.54	M	6.750	171.5
E	2.000 min	50.80 min	N	4.375	111.1
F	2.750 max	69.85 max	P	4.000	101.6
G	6.000	152.4	Q	3.625	92.08
H	0.250	6.35			

Millimetre dimensions have been derived from inches except dimension J.

Outline Notes

1. The mounting flange is the connection for the cathode, cathode heater return, and reservoir heater return.
2. A minimum clearance of 2.000 inches (50.80mm) must be allowed below the mounting flange.
3. The recommended mounting hole is 2.875 inches (73.03mm) diameter.

Whilst EEV has taken care to ensure the accuracy of the information contained herein it accepts no responsibility for the consequences of any use thereof and also reserves the right to change the specification of goods without notice. EEV accepts no liability beyond that set out in its standard conditions of sale in respect of infringement of third party patents arising from the use of tubes or other devices in accordance with information contained herein.



TWO-GAP DOUBLE ENDED CERAMIC THYRATRON

The data to be read in conjunction with the Hydrogen Thyatron Preamble.

ABRIDGED DATA

Deuterium-filled, two-gap, double ended high voltage thyatron with ceramic/metal envelope, featuring low jitter, firing time and drift. Suitable for switching high power and for switching long pulses.

Reservoirs are incorporated, operating from separate heater supplies. The tube is electrically symmetrical, with identical cathode and grid assemblies at both ends; the flange electrode which is positive when the tube is triggered is referred to as the anode.

Peak forward anode voltage	70	kV max
Peak anode current (see page 2)	3000	A max
Average anode current	3.0	A max
Anode heating factor	60×10^9	V.A.p.p.s. max
Peak output power	88	MW max

GENERAL

Electrical

Cathodes (connected internally to one end of associated heater)		oxide coated
Cathode heater voltage (each end)	$6.3 \pm 5\%$	V
Cathode heater current (each end)	21.5	A
Reservoir heater voltage (each end) (see note 1)	5.0	V
Reservoir heater current (each end)	7.0	A
Tube heating time (minimum)	15	min
Inter-electrode capacitances, gradient grid to grid 2 (each end)	15 to 20	pF approx

Mechanical

Seated height (flange to flange)	12.344 inches (313.5mm) nom
Clearance required below flanges	2.000 inches (50.8mm) min
Overall diameter	4.375 inches (111.1mm) nom
Net weight	3.5kg (7.7 pounds) approx
Mounting position (see note 2)	any
Tube connections	see outline

Cooling	forced-air or liquid
Forced-air	see note 3
Liquid	oil or coolant immersion
Maximum temperature of envelope	200 °C

Natural ambient cooling is usually insufficient to maintain the ceramic/metal envelope temperature below the maximum value specified above. Cooling by oil or coolant immersion is advised in view of the high voltages present. Further information is contained in the relevant section of the Preamble.

PULSE MODULATOR SERVICE (See note 4)

MAXIMUM AND MINIMUM RATINGS (Absolute values)

	Min	Max	
Anode			
Peak forward or inverse anode voltage (see note 5)	—	70	kV
Peak anode current	—	3000	A
Peak anode current (pulse repetition rate limited to 60p.p.s. max)	—	4000	A
Average anode current	—	3.0	A
Rate of rise of anode current (see notes 6 and 7)	—	5000	A/μs
Anode heating factor	—	60 x 10 ⁹	V.A.p.p.s.

Grid 2

Unloaded grid 2 drive pulse voltage (see note 8)	200	1000	V
Grid 2 pulse duration	1.0	—	μs
Rate of rise of grid 2 pulse (see note 6)	1.0	—	kV/μs
Grid 2 pulse delay	0.5	3.0	μs
Peak inverse grid 2 voltage	—	450	V
Loaded grid 2 bias voltage	-50	-200	V
Forward impedance of grid 2 drive circuit	50	1000	Ω

Grid 1 – D.C. Primed (See note 9)

D.C. grid 1 unloaded priming voltage	75	150	V
D.C. grid 1 priming current	25	50	mA

MAXIMUM AND MINIMUM RATINGS — continued

	Min	Max	
Grid 1 — Pulsed (See note 10)			
Unloaded grid 1 drive pulse voltage (see note 8)	300	1000	V
Grid 1 pulse duration	2.0	—	μ s
Rate of rise of grid 1 pulse (see note 6)	1.0	—	kV/ μ s
Peak inverse grid 1 voltage	—	450	V
Loaded grid 1 bias voltage			see note 11
Peak grid 1 drive current	0.3	1.0	A
Cathode			
Heater voltage	$6.3 \pm 5\%$		V
Heating time	15	—	min
Reservoir			
Heater voltage (see note 1)	3.5	6.5	V
Heating time	15	—	min
Environmental			
Ambient temperature	-50	+90	$^{\circ}$ C
Altitude	—	10 000	ft
	—	3	km

CHARACTERISTICS

	Min	Typical	Max	
Critical d.c. anode voltage for conduction (see note 12)	—	3.0	5.0	kV
Anode delay time (see notes 12 and 13)	—	0.1	0.25	μ s
Anode delay time drift (see notes 12 and 14)	—	15	50	ns
Time jitter (see note 12)	—	1.0	5.0	ns
Cathode heater current (at 6.3V)	18	21.5	25	A
Reservoir heater current (at 5.0V)	6.0	7.0	9.0	A

RATINGS FOR SINGLE SHOT OR CROWBAR SERVICE (See note 9)

D.C. forward anode voltage	60	kV max
Peak anode current	15 000	A max
Product of peak current and pulse duration	1.0	A.s max
Repetition frequency	1 pulse per 10s	max

NOTES

1. The reservoir heaters must be decoupled with suitable capacitors to avoid damage by spike voltages. The recommended voltage for each tube is marked on the tube, and both reservoirs must be operated at the same heater voltage.
2. The tube must be mounted by one of the cathode flanges, with flexible connections to all other electrodes.
3. An adequate flow of air must be supplied to maintain the ceramic/metal envelope temperature below the maximum rated value.
4. Triggered charging techniques are recommended because the tube has a relatively long recovery time (100–200 μ s).
5. This is the maximum hold off voltage in either direction before the tube is triggered. The maximum permissible peak forward voltage for instantaneous starting is 60kV and there must be no overshoot.
6. This rate of rise refers to that part of the leading edge of the pulse between 25% and 75% of the pulse amplitude.
7. For single shot or burst mode applications this parameter can exceed 100kA/ μ s; the ultimate value which can be attained depends upon the external circuit, but the heating factor must be reduced.
8. Measured with respect to the associated cathode. The tube is triggered by pulsing the grid 2 at the negative end, while the grid 2 at the anode (positive) end is normally connected to its associated cathode and carries most of the forward anode current. When grid 1 is pulse driven, the last 0.25 μ s of the top of the grid 1 pulse must overlap the corresponding first 0.25 μ s of the top of the delayed grid 2 pulse.
9. When d.c. priming is used on grid 1, a negative bias of 100 to 200V must be applied to grid 2 to ensure anode voltage hold-off. D.C. priming of grid 1 at both ends is recommended for crowbar service.
10. When pulse drive is applied to the triggered end of the tube, the grid 1 at the anode (positive) end will normally be d.c. primed.
11. D.C. negative bias voltages must not be applied to grid 1. When grid 1 is pulse driven, the potential of grid 1 may vary between –10 and +5V with respect to cathode during the period between the completion of recovery and the start of the next grid pulse.

12. Typical figures are obtained on test using conditions of minimum grid 2 drive. Improved performance can be expected with increased grid drive.
13. The time interval between the instant at which the rising unloaded grid 2 pulse reaches 25% of its pulse amplitude and the instant when anode conduction takes place.
14. The drift in delay time over a period from 10 seconds to 10 minutes after reaching full voltage.

X-RAY WARNING

X-rays may be emitted by the CX1168B but the radiation is usually reduced to a safe level by the metal surrounds and panels of the equipment in which the tube operates.

SCHEMATIC DIAGRAM

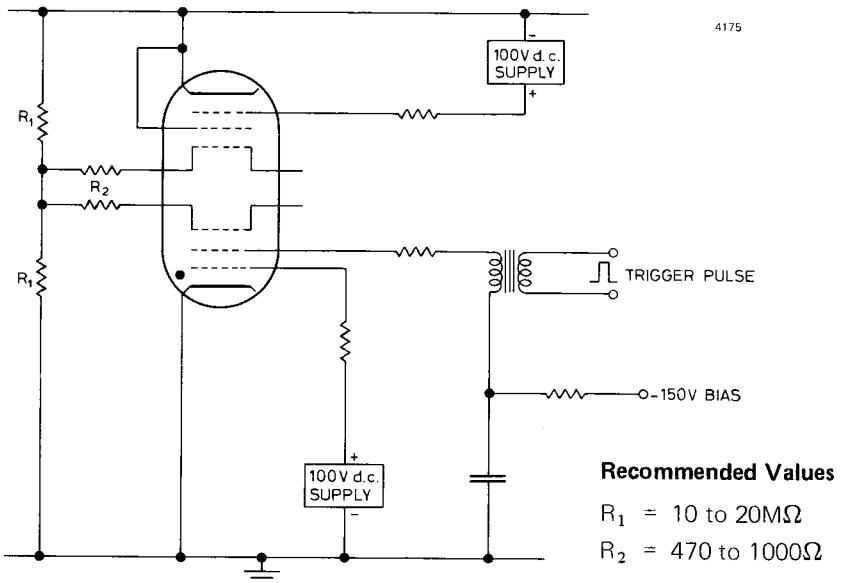

OUTLINE

4178

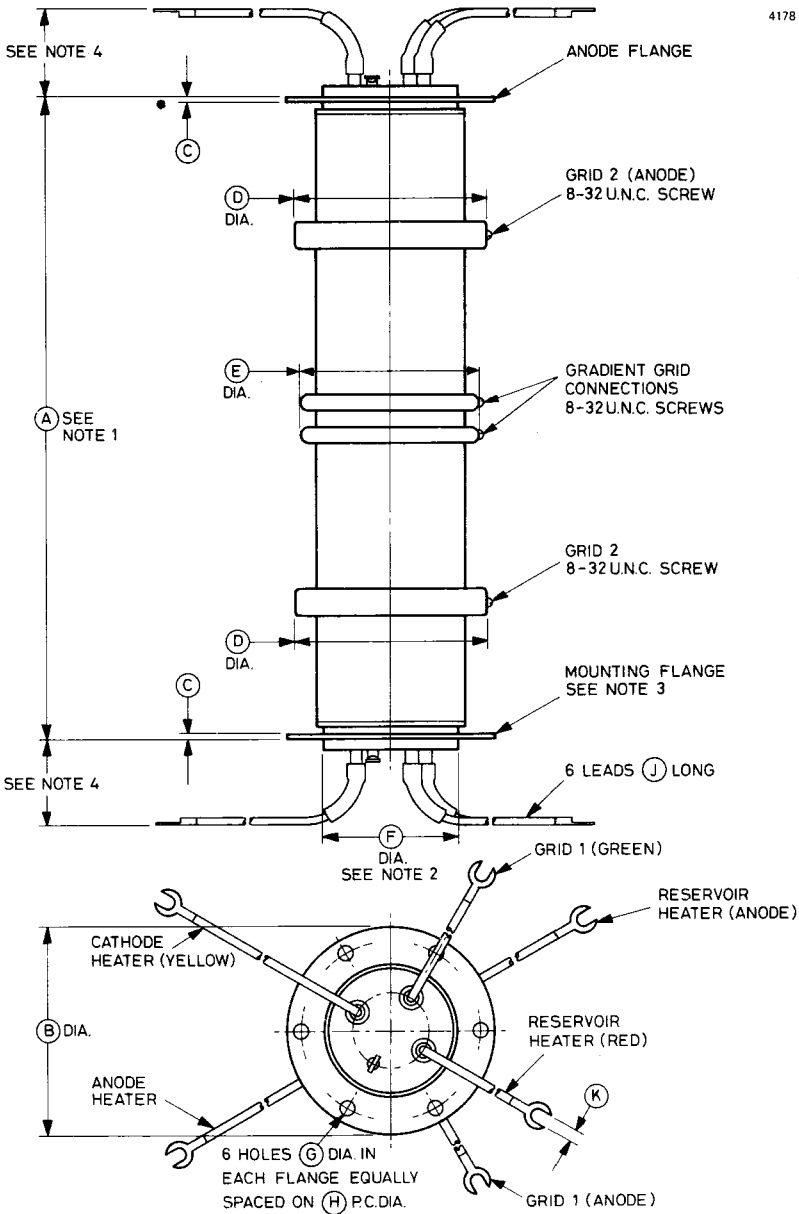

Outline Dimensions (All dimensions without limits are nominal)

Ref	Inches	Millimetres
A	12.344 ± 0.100	313.54 ± 2.54
B	4.375	111.1
C	0.100	2.54
D	4.000 ± 0.062	101.6 ± 1.6
E	3.625 ± 0.062	92.08 ± 1.57
F	2.750 max	69.85 max
G	0.256	6.50
H	3.750	95.25
J	6.000 min	152.4 min
K	0.250	6.35

Millimetre dimensions have been derived from inches.

Outline Notes

1. The two flanges will be parallel within 0.059 inch (1.5mm).
2. The recommended mounting hole is 2.875 inches (73.03mm) diameter.
3. The tube must be mounted by one flange only. The flange is the connection for the cathode, cathode heater return and reservoir heater return.
4. A minimum clearance of 2.000 inches (50.80mm) must be allowed below the flange.

Whilst EEV has taken care to ensure the accuracy of the information contained herein it accepts no responsibility for the consequences of any use thereof and also reserves the right to change the specification of goods without notice. EEV accepts no liability beyond that set out in its standard conditions of sale in respect of infringement of third party patents arising from the use of tubes or other devices in accordance with information contained herein.

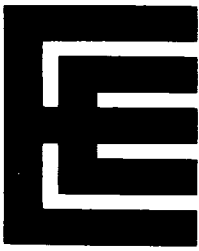

CX1171

THREE-GAP CERAMIC THYRATRON

The data to be read in conjunction with the Hydrogen Thyatron Preamble.

ABRIDGED DATA

Deuterium-filled, three-gap, high voltage thyatron with ceramic/metal envelope, featuring low jitter, firing time and drift. Suitable for switching high power at high pulse repetition rates or for switching long pulses. A reservoir operating from a separate heater supply is incorporated.

Peak forward anode voltage	120	kV max
Peak anode current (see page 2)	3000	A max
Average anode current	3.0	A max
Anode heating factor	70×10^9	V.A.p.p.s. max
Peak output power	150	MW max

GENERAL

Electrical

Cathode (connected internally to one end of heater)	oxide coated
Cathode heater voltage	$6.3 \pm 5\%$ V
Cathode heater current	21.5 A
Reservoir heater voltage (see note 1)	5.0 V
Reservoir heater current	7.0 A
Tube heating time (minimum)	15 min
Inter-electrode capacitances (approximate):	
anode to gradient grid 2	15 to 20 pF
gradient grid 2 to gradient grid 1	15 to 20 pF
gradient grid 1 to grid 2	15 to 20 pF

Mechanical

Seated height	13.500 inches (342.9mm) max
Clearance required below mounting flange	2.000 inches (50.8mm) min
Overall diameter (mounting flange)	4.375 inches (111.1mm) nom
Net weight	8 $\frac{3}{4}$ pounds (4.0kg) approx
Mounting position (see note 2)	any
Tube connections	see outline

Cooling	forced-air or liquid
Forced-air	see note 3
Liquid	oil or coolant immersion
Maximum temperature of envelope	200 °C

Natural ambient cooling is usually insufficient to maintain the ceramic/metal envelope temperature below the maximum value specified above. Cooling by oil or coolant immersion is advised in view of the high voltages present. Further information is contained in the relevant section of the Preamble.

PULSE MODULATOR SERVICE

MAXIMUM AND MINIMUM RATINGS (Absolute values)

	Min	Max	
Anode			
Peak forward anode voltage (see note 4)	—	120	kV
Peak inverse anode voltage (see note 5)	—	120	kV
Peak anode current	—	3000	A
Peak anode current (pulse repetition rate limited to 60p.p.s. max)	—	4000	A
Average anode current	—	3.0	A
Rate of rise of anode current (see notes 6 and 7)	—	5000	A/ μ s
Anode heating factor	—	70×10^9	V.A.p.p.s.

Grid 2

Unloaded grid 2 drive pulse voltage (see note 8)	200	1000	V
Grid 2 pulse duration	1.0	—	μ s
Rate of rise of grid 2 pulse (see note 7)	1.0	—	kV/ μ s
Grid 2 pulse delay	0.5	3.0	μ s
Peak inverse grid 2 voltage	—	450	V
Loaded grid 2 bias voltage (see note 9)	—50	—200	V
Forward impedance of grid 2 drive circuit	50	1000	Ω

Grid 1 — D.C. Primed (See note 10)

D.C. grid 1 unloaded priming voltage	75	150	V
D.C. grid 1 priming current	75	150	mA

MAXIMUM AND MINIMUM RATINGS – continued

Grid 1 – Pulsed

	Min	Max	
Unloaded grid 1 drive pulse voltage (see note 8)	300	1000	V
Grid 1 pulse duration	2.0	—	μ s
Rate of rise of grid 1 pulse (see note 7)	1.0	—	kV/ μ s
Peak inverse grid 1 voltage	—	450	V
Loaded grid 1 bias voltage			see note 11
Peak grid 1 drive current	0.3	1.0	A

Cathode

Heater voltage		$6.3 \pm 5\%$	V
Heating time	15	—	min

Reservoir

Heater voltage (see note 1)	4.5	6.5	V
Heating time	15	—	min

Environmental

Ambient temperature	–50	+90	$^{\circ}$ C
Altitude	—	10 000	ft
	—	3	km

CHARACTERISTICS

	Min	Typical	Max	
Critical d.c. anode voltage for conduction (see note 12)	—	5.0	7.0	kV
Anode delay time (see notes 12 and 13)	—	0.1	0.25	μ s
Anode delay time drift (see notes 12 and 14)	—	15	50	ns
Time jitter (see note 12)	—	1.0	5.0	ns
Cathode heater current (at 6.3V)	18	21.5	25	A
Reservoir heater current (at 5.0V)	6.0	7.0	9.0	A

RATINGS FOR SINGLE SHOT OR CROWBAR SERVICE (See note 10)

D.C. forward anode voltage		105	kV max
Peak anode current		15 000	A max
Product of peak current and pulse length		0.1	A.s max
Repetition frequency		1 pulse per 10s	max

NOTES

1. The reservoir heater must be decoupled with a suitable capacitor to avoid damage by spike voltages. The recommended reservoir heater voltage is stamped on individual tube envelopes.
2. The tube must be mounted by means of its mounting flange.
3. An adequate flow of air must be supplied to maintain the ceramic/metal envelope temperature below the maximum rated value.
4. The maximum permissible peak forward voltage for instantaneous starting is 60kV and there must be no overshoot.
5. The peak inverse voltage including spike must not exceed 20kV for the first 125 microseconds after the anode pulse.
6. For single shot or burst mode applications this parameter can exceed 100kA/ μ s. The ultimate value which can be attained depends to a large extent upon the external circuit.
7. This rate of rise refers to that part of the leading edge of the pulse between 25% and 75% of the pulse amplitude.
8. Measured with respect to cathode. When grid 1 is pulse driven, the last 0.25 μ s of the top of the grid 1 pulse must overlap the corresponding first 0.25 μ s of the top of the delayed grid 2 pulse.
9. The tube may be operated with a loaded grid 2 bias voltage of 0 to -50V provided that care is taken to ensure that the peak grid 1 drive current is sufficiently low to prevent triode firing (tube control by the grid 1 pulse).
10. When d.c. priming is used on grid 1, a negative bias of 100 to 200V must be applied to grid 2 to ensure anode voltage hold-off. D.C. priming is recommended for pulse modulator and crowbar service.
11. D.C. negative bias voltages must not be applied to grid 1. When grid 1 is pulse driven, the potential of grid 1 may vary between -10 and +5V with respect to cathode potential during the period between the completion of recovery and the commencement of the succeeding grid pulse.
12. Typical figures are obtained on test using conditions of minimum grid drive. Improved performance can be expected by increasing grid drive.

13. The time interval between the instant at which the rising unloaded grid 2 pulse reaches 25% of its pulse amplitude and the instant when anode conduction takes place.
14. The drift in delay time over a period from 10 seconds to 10 minutes
 - after reaching full voltage.

X-RAY WARNING

X-rays may be emitted by the CX1171 but the radiation is usually reduced to a safe level by the metal panels of the equipment in which the tube operates.

SCHEMATIC DIAGRAM

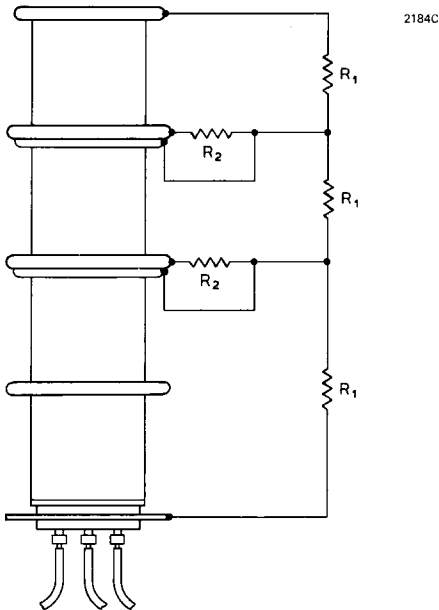

Recommended Values

$$R_1 = 10 \text{ to } 20\text{M}\Omega$$

$$R_2 = 470 \text{ to } 1000\Omega$$

Please consult EEV for alternative methods of connection.

OUTLINE

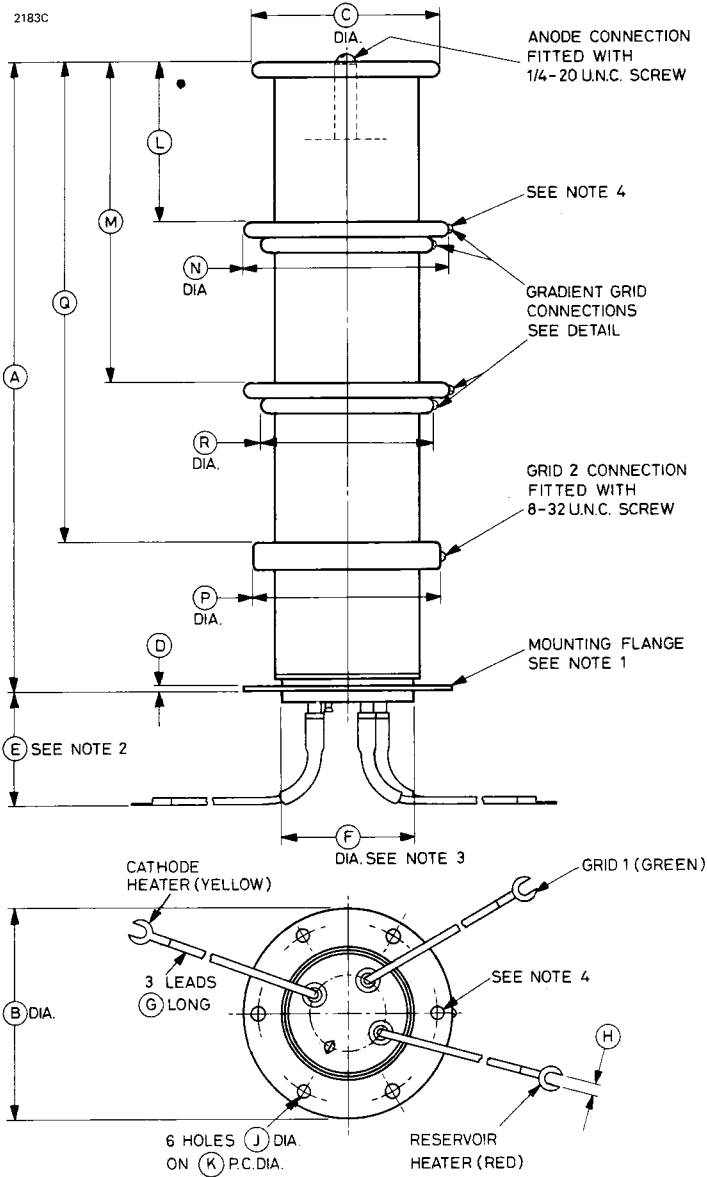

Detail of Gradient Grid Connections

3573A

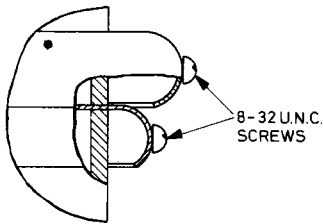

Outline Dimensions (All dimensions without limits are nominal)

Ref	Inches	Millimetres	Ref	Inches	Millimetres
A	13.500 max	342.9 max	J	0.256	6.50
B	4.375	111.1	K	3.750	95.25
C	4.000	101.6	L	3.375	85.73
D	0.100	2.54	M	6.750	171.5
E	2.000 min	50.80 min	N	4.375	111.1
F	2.750 max	69.85 max	P	4.000	101.6
G	6.000	152.4	Q	10.125	257.2
H	0.250	6.35	R	3.625	92.08

Millimetre dimensions have been derived from inches except dimension J.

Outline Notes

1. The mounting flange is the connection for the cathode, cathode heater return and reservoir heater return.
2. A minimum clearance of 2.000 inches (50.80mm) must be allowed below the mounting flange.
3. The recommended mounting hole is 2.875 inches (73.03mm) diameter.
4. The holes for all grid connections will be in line with the hole in the mounting flange to within 10° either side of the hole centre.

Whilst EEV has taken care to ensure the accuracy of the information contained herein it accepts no responsibility for the consequences of any use thereof and also reserves the right to change the specification of goods without notice. EEV accepts no liability beyond that set out in its standard conditions of sale in respect of infringement of third party patents arising from the use of tubes or other devices in accordance with information contained herein.



THREE-GAP DOUBLE ENDED CERAMIC THYRATRON

The data to be read in conjunction with the Hydrogen Thyatron Preamble.

ABRIDGED DATA

Deuterium-filled, three-gap, double ended high voltage thyatron with ceramic/metal envelope, featuring low jitter, firing time and drift. Suitable for switching high power and for switching long pulses. Reservoirs are incorporated, operating from separate heater supplies. The tube is electrically symmetrical, with identical cathode and grid assemblies at both ends; the flange electrode which is positive when the tube is triggered is referred to as the anode.

Peak forward anode voltage	105	kV max
Peak anode current (see page 2)	3000	A max
Average anode current	3.0	A max
Anode heating factor	60 x 10 ⁹ V.A.p.p.s.	max
Peak output power	130	MW max

GENERAL

Electrical

Cathodes (connected internally to one end of associated heater)		oxide coated
Cathode heater voltage (each end)	6.3 ± 5%	V
Cathode heater current (each end)	21.5	A
Reservoir heater voltage (each end) (see note 1)	5.0	V
Reservoir heater current (each end)	7.0	A
Tube heating time (minimum)	15	min
Inter-electrode capacitances (each gap)	15 to 20	pF approx

Mechanical

Seated height (flange to flange)	15.787 inches (401.0mm)	nom
Clearance required below flanges	2.000 inches (50.8mm)	min
Overall diameter	4.375 inches (111.1mm)	nom
Net weight	10.3 pounds (4.7kg)	approx
Mounting position (see note 2)		any
Tube connections		see outline

Cooling	forced-air or liquid
Forced-air	see note 3
Liquid	oil or coolant immersion
Maximum temperature of envelope	200 °C

Natural ambient cooling is usually insufficient to maintain the ceramic/metal envelope temperature below the maximum value specified above. Cooling by oil or coolant immersion is advised in view of the high voltages present. Further information is contained in the relevant section of the Preamble.

PULSE MODULATOR SERVICE (See note 4)

MAXIMUM AND MINIMUM RATINGS (Absolute values)

	Min	Max	
Anode			
Peak forward or inverse anode voltage (see note 5)	—	105	kV
Peak anode current	—	3000	A
Peak anode current (pulse repetition rate limited to 60p.p.s. max)	—	4000	A
Average anode current	—	3.0	A
Rate of rise of anode current (see notes 6 and 7)	—	5000	A/μs
Anode heating factor	—	60 x 10 ⁹	V.A.p.p.s.

Grid 2

Unloaded grid 2 drive pulse voltage (see note 8)	200	1000	V
Grid 2 pulse duration	1.0	—	μs
Rate of rise of grid 2 pulse (see note 6)	1.0	—	kV/μs
Grid 2 pulse delay	0.5	3.0	μs
Peak inverse grid 2 voltage	—	450	V
Loaded grid 2 bias voltage	-50	-200	V
Forward impedance of grid 2 drive circuit	50	1000	Ω

Grid 1 – D.C. Primed (See note 9)

D.C. grid 1 unloaded priming voltage	75	150	V
D.C. grid 1 priming current	25	50	mA

MAXIMUM AND MINIMUM RATINGS — continued

	Min	Max	
Grid 1 — Pulsed (See note 10)			
Unloaded grid 1 drive pulse voltage (see note 8)	300	1000	V
Grid 1 pulse duration	2.0	—	μ s
Rate of rise of grid 1 pulse (see note 6)	1.0	—	kV/ μ s
Peak inverse grid 1 voltage	—	450	V
Loaded grid 1 bias voltage	—	—	see note 11
Peak grid 1 drive current	0.3	1.0	A
Cathodes			
Heater voltage	$6.3 \pm 5\%$	—	V
Heating time	15	—	min
Reservoirs			
Heater voltage (see note 1)	3.5	6.5	V
Heating time	15	—	min
Environmental			
Ambient temperature	-50	+90	$^{\circ}$ C
Altitude	—	10 000	ft
	—	3	km

CHARACTERISTICS

	Min	Typical	Max	
Critical d.c. anode voltage for conduction (see note 12)	—	5.0	7.0	kV
Anode delay time (see notes 12 and 13)	—	0.1	0.25	μ s
Anode delay time drift (see notes 12 and 14)	—	15	50	ns
Time jitter (see note 12)	—	1.0	5.0	ns
Cathode heater current (at 6.3V)	18	21.5	25	A
Reservoir heater current (at 5.0V)	6.0	7.0	9.0	A

RATINGS FOR SINGLE SHOT OR CROWBAR SERVICE (See note 9)

D.C. forward anode voltage	90	kV max
Peak anode current	15 000	A max
Product of peak current and pulse duration	1.0	A.s max
Repetition frequency	1 pulse per 10s	max

NOTES

1. The reservoir heaters must be decoupled with suitable capacitors to avoid damage by spike voltages. The recommended voltage for each tube is marked on the tube, and both reservoirs must be operated at the same heater voltage.
2. The tube must be mounted by one of the cathode flanges, with flexible connections to all other electrodes.
3. An adequate flow of air must be supplied to maintain the ceramic/metal envelope temperature below the maximum rated value.
4. Triggered charging techniques are recommended because the tube has a relatively long recovery time (100–200 μ s).
5. This is the maximum hold off voltage in either direction before the tube is triggered. The maximum permissible peak forward voltage for instantaneous starting is 90kV and there must be no overshoot.
6. This rate of rise refers to that part of the leading edge of the pulse between 25% and 75% of the pulse amplitude.
7. For single shot or burst mode applications this parameter can exceed 100kA/ μ s; the ultimate value which can be attained depends upon the external circuit, but the heating factor must be reduced.
8. Measured with respect to the associated cathode. The tube is triggered by pulsing the grid 2 at the negative end, while the grid 2 at the anode (positive) end is connected to its associated cathode and carries most of the forward anode current. When grid 1 is pulse driven, the last 0.25 μ s of the top of the grid 1 pulse must overlap the corresponding first 0.25 μ s of the top of the delayed grid 2 pulse.
9. When d.c. priming is used on grid 1, a negative bias of 100 to 200V must be applied to grid 2 to ensure anode voltage hold-off. D.C. priming of grid 1 at both ends is recommended for crowbar service.
10. When pulse drive is applied to the triggered end of the tube, the grid 1 at the anode (positive) end will normally be d.c. primed.
11. D.C. negative bias voltages must not be applied to grid 1. When grid 1 is pulse driven, the potential of grid 1 may vary between –10 and +5V with respect to cathode during the period between the completion of recovery and the start of the next grid pulse.

OUTLINE

4179A

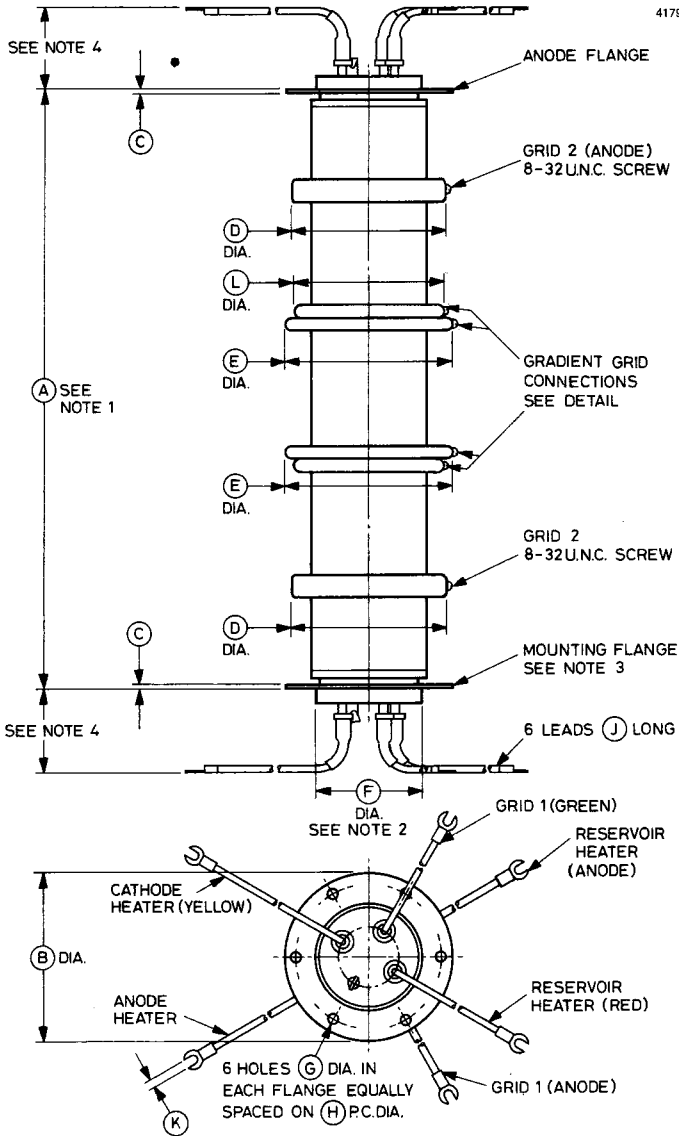

Whilst EEV has taken care to ensure the accuracy of the information contained herein it accepts no responsibility for the consequences of any use thereof and also reserves the right to change the specification of goods without notice. EEV accepts no liability beyond that set out in its standard conditions of sale in respect of infringement of third party patents arising from the use of tubes or other devices in accordance with information contained herein.

Detail of Gradient Grid Connections

3573A

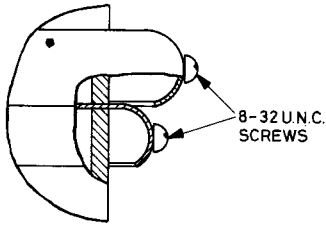

Outline Dimensions (All dimensions without limits are nominal)

Ref	Inches	Millimetres
A	15.787 ± 0.100	400.99 ± 2.54
B	4.375	111.1
C	0.100	2.54
D	4.000 ± 0.062	101.6 ± 1.6
E	4.375 ± 0.062	111.1 ± 1.6
F	2.750 max	69.85 max
G	0.256	6.50
H	3.750	95.25
J	6.000 min	152.4 min
K	0.250	6.35
L	3.625	92.08

Millimetre dimensions have been derived from inches.

Outline Notes

1. The two flanges will be parallel within 0.059 inch (1.5mm).
2. The recommended mounting hole is 2.875 inches (73.03mm) diameter.
3. The tube must be mounted by one flange only. The flange is the connection for the cathode, cathode heater return and reservoir heater return.
4. A minimum clearance of 2.000 inches (50.80mm) must be allowed below the flange.



CX1174

DEUTERIUM-FILLED CERAMIC THYRATRON

The data to be read in conjunction with the Hydrogen Thyatron Preamble.

ABRIDGED DATA

Deuterium-filled tetrode thyatron with ceramic/metal envelope, featuring low jitter, firing time and drift. Suitable for switching high power at high pulse repetition rates or for switching long pulses. A reservoir operating from a separate heater supply is incorporated.

Peak forward anode voltage	40	kV max
Peak anode current (see page 2)	6000	A max
Average anode current	6.0	A max
Anode heating factor	60×10^9	V.A.p.p.s. max
Peak output power	120	MW max

GENERAL

Electrical

Cathode (connected internally to one end of heater)	oxide coated
Cathode heater voltage	$6.3 \pm 5\%$ V
Cathode heater current	40 A
Reservoir heater voltage (see note 1)	5.0 V
Reservoir heater current	10 A
Tube heating time (minimum)	15 min
Anode to grid 2 capacitance	40 pF

Mechanical

Seated height	8.312 inches (211.1mm) max
Clearance required below mounting flange	2.500 inches (63.5mm) min
Overall diameter (mounting flange)	6.000 inches (152.4mm) nom
Net weight	7¼ pounds (3.5kg) approx
Mounting position (see note 2)	any
Tube connections	see outline

Cooling	forced-air or liquid
Forced-air	see note 3
Liquid	oil or coolant immersion
Maximum temperature of envelope	200 °C

Natural ambient cooling is usually insufficient to maintain the ceramic/metal envelope temperature below the maximum value specified above. Cooling by oil or coolant immersion is advised in view of the high voltages present. Further information is contained in the relevant section of the Preamble.

PULSE MODULATOR SERVICE

MAXIMUM AND MINIMUM RATINGS (Absolute values)

	Min	Max	
Anode			
Peak forward anode voltage (see note 4)	—	40	kV
Peak inverse anode voltage (see note 5)	—	40	kV
Peak anode current	—	6000	A
Peak anode current (pulse repetition rate limited to 60p.p.s. max)	—	8000	A
Average anode current	—	6.0	A
Rate of rise of anode current (see notes 6 and 7)	—	10 000	A/μs
Anode heating factor	—	60 x 10 ⁹	V.A.p.p.s.

Grid 2

Unloaded grid 2 drive pulse voltage (see note 8)	400	2000	V
Grid 2 pulse duration	1.0	—	μs
Rate of rise of grid 2 pulse (see note 7)	1.0	—	kV/μs
Grid 2 pulse delay	0.5	3.0	μs
Peak inverse grid 2 voltage	—	450	V
Loaded grid 2 bias voltage (see note 9)	−50	−200	V
Forward impedance of grid 2 drive circuit	50	500	Ω

Grid 1 – D.C. Primed (See note 10)

D.C. grid 1 unloaded priming voltage	75	150	V
D.C. grid 1 priming current	75	150	mA

MAXIMUM AND MINIMUM RATINGS — continued

Grid 1 — Pulsed	Min	Max	
Unloaded grid 1 drive pulse voltage (see note 8)	400	1000	V
Grid 1 pulse duration	2.0	—	μs
Rate of rise of grid 1 pulse (see note 7)	1.0	—	kV/μs
Peak inverse grid 1 voltage	—	450	V
Loaded grid 1 bias voltage			see note 11
Peak grid 1 drive current	0.5	1.5	A

Cathode

Heater voltage	6.3 ± 5%		V
Heating time	15	—	min

Reservoir

Heater voltage (see note 1)	4.5	6.5	V
Heating time	15	—	min

Environmental

Ambient temperature	−50	+90	°C
Altitude	—	10 000	ft
	—	3	km

CHARACTERISTICS

	Min	Typical	Max	
Critical d.c. anode voltage for conduction (see note 12)	—	0.5	1.0	kV
Anode delay time (see notes 12 and 13)	—	0.1	0.25	μs
Anode delay time drift (see notes 12 and 14)	—	15	50	ns
Time jitter (see note 12)	—	1.0	5.0	ns
Cathode heater current (at 6.3V)	35	40	45	A
Reservoir heater current (at 5.0V)	8.0	10	12	A

RATINGS FOR SINGLE SHOT OR CROWBAR SERVICE (See note 10)

D.C. forward anode voltage	35	kV max
Peak anode current	60 000	A max
Product of peak current and pulse length	0.2	A.s max
Repetition frequency	1 pulse per 10s	max

NOTES

1. The reservoir heater must be decoupled with a suitable capacitor to avoid damage by spike voltages. The recommended reservoir heater voltage is stamped on individual tube envelopes.
2. The tube must be mounted by means of its mounting flange.
3. An adequate flow of air must be supplied to maintain the ceramic/metal envelope temperature below the maximum rated value.
4. The maximum permissible peak forward voltage for instantaneous starting is 30kV and there must be no overshoot.
5. The peak inverse voltage including spike must not exceed 10kV for the first 25 microseconds after the anode pulse.
6. For single shot or burst mode applications this parameter can exceed 100kA/ μ s. The ultimate value which can be attained depends to a large extent upon the external circuit.
7. This rate of rise refers to that part of the leading edge of the pulse between 25% and 75% of the pulse amplitude.
8. Measured with respect to cathode. When grid 1 is pulse driven, the last 0.25 μ s of the top of the grid 1 pulse must overlap the corresponding first 0.25 μ s of the top of the delayed grid 2 pulse.
9. The tube may be operated with a loaded grid 2 bias voltage of 0 to -50V provided that care is taken to ensure that the peak grid 1 drive current is sufficiently low to prevent triode firing (tube control by the grid 1 pulse).
10. When d.c. priming is used on grid 1, a negative bias of 100 to 200V must be applied to grid 2 to ensure anode voltage hold-off. D.C. priming is recommended for pulse modulator and crowbar service.
11. D.C. negative bias voltages must not be applied to grid 1. When grid 1 is pulse driven, the potential of grid 1 may vary between -10 and +5V with respect to cathode potential during the period between the completion of recovery and the commencement of the succeeding grid pulse.
12. Typical figures are obtained on test using conditions of minimum grid drive. Improved performance can be expected by increasing grid drive.

13. The time interval between the instant at which the rising unloaded grid 2 pulse reaches 25% of its pulse amplitude and the instant when anode conduction takes place.
14. The drift in delay time over a period from 10 seconds to 10 minutes
 - after reaching full voltage.

X-RAY WARNING

X-rays may be emitted by the CX1174 but the radiation is usually reduced to a safe level by the metal panels of the equipment in which the tube operates.

OUTLINE

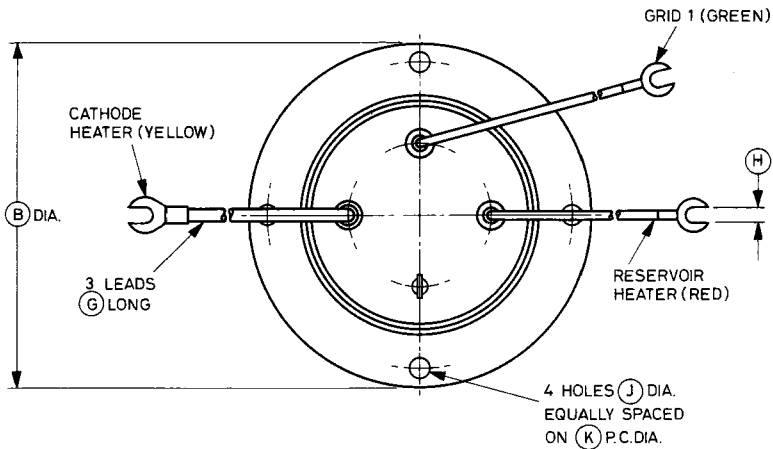
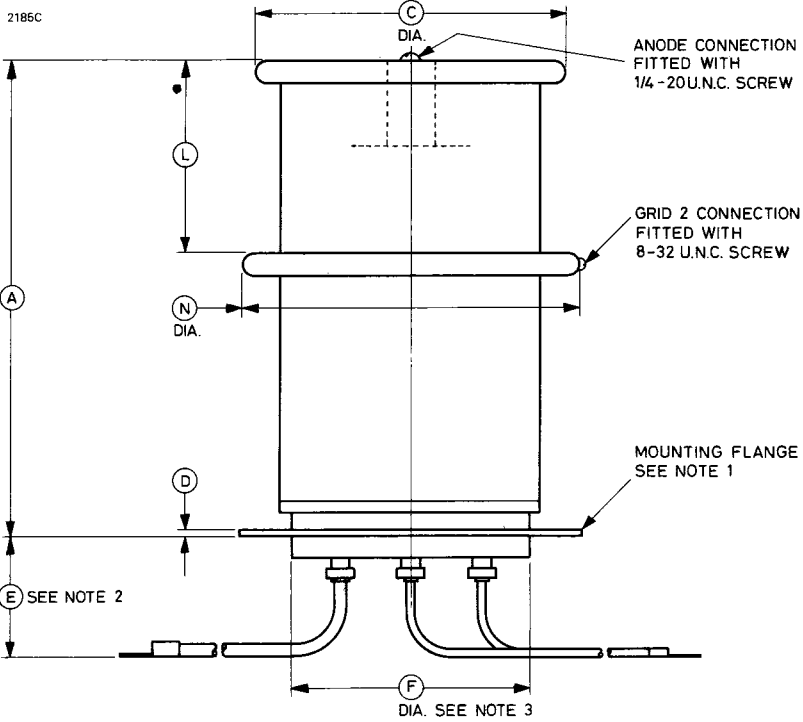

Outline Dimensions (All dimensions without limits are nominal)

Ref	Inches	Millimetres
A ●	8.312 max	211.1 max
B	6.000	152.4
C	5.500	139.7
D	0.125	3.18
E	2.500 min	63.50 min
F	4.187 max	106.3 max
G	7.000	177.8
H	0.250	6.35
J	0.315	8.0
K	5.344	135.7
L	3.375	85.73
N	5.875	149.2

Millimetre dimensions have been derived from inches except dimension J.

Outline Notes

1. The mounting flange is the connection for the cathode, cathode heater return and reservoir heater return.
2. A minimum clearance of 2.500 inches (63.50mm) must be allowed below the mounting flange.
3. The recommended mounting hole is 4.250 inches (108mm) diameter.



DOUBLE ENDED CERAMIC THYRATRON

The data to be read in conjunction with the Hydrogen Thyatron Preamble.

ABRIDGED DATA

Deuterium-filled, double ended high voltage thyatron with ceramic/metal envelope, featuring low jitter, firing time and drift. Suitable for switching high power and for switching long pulses.

Reservoirs are incorporated, operating from separate heater supplies. The tube is electrically symmetrical, with identical cathode and grid assemblies at both ends; the flange electrode which is positive when the tube is triggered is referred to as the anode.

Peak forward anode voltage	35	kV max
Peak anode current (see page 2)	6000	A max
Average anode current	6.0	A max
Anode heating factor	60×10^9	V.A.p.p.s. max
Peak output power	100	MW max

GENERAL

Electrical

Cathodes (connected internally to one end of associated heater)		oxide coated
Cathode heater voltage (each end)	$6.3 \pm 5\%$	V
Cathode heater current (each end)	40	A
Reservoir heater voltage (each end) (see note 1)	5.0	V
Reservoir heater current (each end)	10	A
Tube heating time (minimum)	15	min
Inter-electrode capacitances, 'anode' to grid 2	40	pF approx

Mechanical

Seated height (flange to flange)	12.780 inches (324.6mm)	nom
Clearance required below flanges	2.500 inches (63.5mm)	min
Overall diameter	6.000 inches (152.4mm)	nom
Net weight	10.25 pounds (4.65kg)	approx
Mounting position (see note 2)		any
Tube connections		see outline

Cooling	forced-air or liquid
Forced-air	see note 3
Liquid	oil or coolant immersion
Maximum temperature of envelope	200 °C

Natural ambient cooling is usually insufficient to maintain the ceramic/metal envelope temperature below the maximum value specified above. Cooling by oil or coolant immersion is advised in view of the high voltages present. Further information is contained in the relevant section of the Preamble.

PULSE MODULATOR SERVICE (See note 4)

MAXIMUM AND MINIMUM RATINGS (Absolute values)

	Min	Max	
Anode			
Peak forward or inverse anode voltage (see note 5)	—	35	kV
Peak anode current	—	6000	A
Peak anode current (pulse repetition rate limited to 60p.p.s. max)	—	8000	A
Average anode current	—	6.0	A
Rate of rise of anode current (see notes 6 and 7)	—	10 000	A/μs
Anode heating factor	—	60 x 10 ⁹	V.A.p.p.s.

Grid 2

Unloaded grid 2 drive pulse voltage (see note 8)	400	2000	V
Grid 2 pulse duration	1.0	—	μs
Rate of rise of grid 2 pulse (see note 6)	1.0	—	kV/μs
Grid 2 pulse delay	0.5	3.0	μs
Peak inverse grid 2 voltage	—	450	V
Loaded grid 2 bias voltage	-50	-200	V
Forward impedance of grid 2 drive circuit	50	500	Ω

Grid 1 – D.C. Primed (see note 9)

D.C. grid 1 unloaded priming voltage	75	150	V
D.C. grid 1 priming current	25	50	mA

MAXIMUM AND MINIMUM RATINGS — continued

	Min	Max	
Grid 1 — Pulsed (see note 10)			
Unloaded grid 1 drive pulse voltage (see note 8)	400	1000	V
Grid 1 pulse duration	2.0	—	μ s
Rate of rise of grid 1 pulse (see note 6)	1.0	—	kV/ μ s
Peak inverse grid 1 voltage	—	450	V
Loaded grid 1 bias voltage	—	—	see note 11
Peak grid 1 drive current	0.5	1.5	A

Cathodes

Heater voltage	$6.3 \pm 5\%$	—	V
Heating time	15	—	min

Reservoirs

Heater voltage (see note 1)	3.5	6.5	V
Heating time	15	—	min

Environmental

Ambient temperature	-50	+90	$^{\circ}$ C
Altitude	—	10 000	ft
	—	3	km

CHARACTERISTICS

	Min	Typical	Max	
Critical d.c. anode voltage for conduction (see note 12)	—	0.3	0.5	kV
Anode delay time (see notes 12 and 13)	—	0.1	0.25	μ s
Anode delay time drift (see notes 12 and 14)	—	15	50	ns
Time jitter (see note 12)	—	1.0	5.0	ns
Cathode heater current (at 6.3V)	35	40	45	A
Reservoir heater current (at 5.0V)	8.0	10	12	A

RATINGS FOR SINGLE SHOT OR CROWBAR SERVICE (see note 9)

D.C. forward anode voltage	30	kV max
Peak anode current	60 000	A max
Product of peak current and pulse duration	2.0	A.s max
Repetition frequency	1 pulse per 10s	max

NOTES

1. The reservoir heaters must be decoupled with suitable capacitors to avoid damage by spike voltages. The recommended voltage for each tube is marked on the tube, and both reservoirs must be operated at the same heater voltage.
2. The tube must be mounted by one of the cathode flanges, with flexible connections to all other electrodes.
3. An adequate flow of air must be supplied to maintain the ceramic/metal envelope temperature below the maximum rated value.
4. Triggered charging techniques are recommended because the tube has a relatively long recovery time (100–200 μ s).
5. This is the maximum hold off voltage in either direction before the tube is triggered. The maximum permissible peak forward voltage for instantaneous starting is 30kV and there must be no overshoot.
6. This rate of rise refers to that part of the leading edge of the pulse between 25% and 75% of the pulse amplitude.
7. For single shot or burst mode applications this parameter can exceed 100kA/ μ s; the ultimate value which can be attained depends upon the external circuit, but the heating factor must be reduced.
8. Measured with respect to the associated cathode. The tube is triggered by pulsing the grid 2 at the negative end, while the grid 2 at the anode (positive) end is connected to its associated cathode and carries most of the forward anode current. When grid 1 is pulse driven, the last 0.25 μ s of the top of the grid 1 pulse must overlap the corresponding first 0.25 μ s of the top of the delayed grid 2 pulse.
9. When d.c. priming is used on grid 1, a negative bias of 100 to 200V must be applied to grid 2 to ensure anode voltage hold-off. D.C. priming of grid 1 at both ends is recommended for crowbar service.
10. When pulse drive is applied to the triggered end of the tube, the grid 1 at the anode (positive) end will normally be d.c. primed.
11. D.C. negative bias voltages must not be applied to grid 1. When grid 1 is pulse driven, the potential of grid 1 may vary between –10 and +5V with respect to cathode during the period between the completion of recovery and the start of the next grid pulse.

12. Typical figures are obtained on test using conditions of minimum grid drive. Improved performance can be expected with increased grid drive.
13. The time interval between the instant at which the rising unloaded grid 2 pulse reaches 25% of its pulse amplitude and the instant when anode conduction takes place.
14. The drift in delay time over a period from 10 seconds to 10 minutes after reaching full voltage.

X-RAY WARNING

X-rays may be emitted by the CX1174B but the radiation is usually reduced to a safe level by the metal surrounds and panels of the equipment in which the tube operates.

SCHEMATIC DIAGRAM

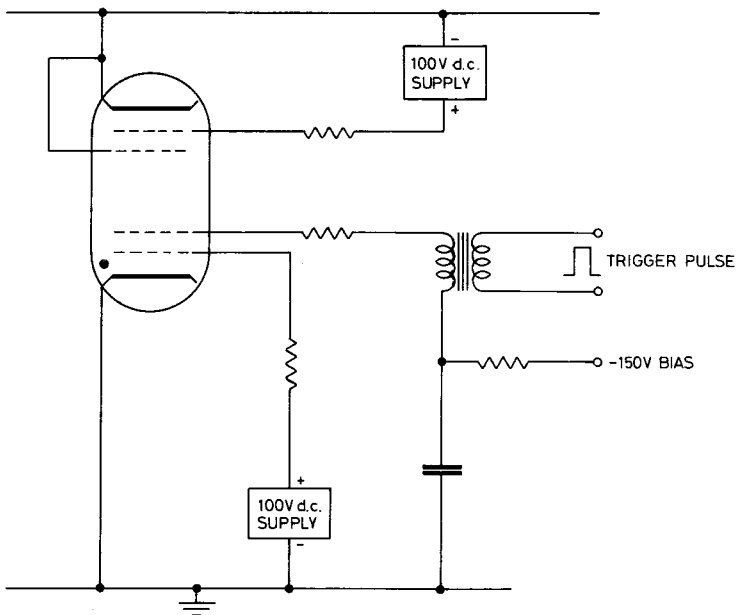

Outline Dimensions (All dimensions without limits are nominal)

Ref	Inches	Millimetres
A	12.780 ± 0.100	324.6 ± 2.54
B	6.000	152.4
C	0.125	3.18
D	5.875	149.2
F	4.187 max	106.3 max
G	0.315	8.0
H	5.344	135.7
J	7.000	177.8
K	0.250	6.35

Millimetre dimensions have been derived from inches.

Outline Notes

1. The two flanges will be parallel within 0.059 inch (1.5mm).
2. The recommended mounting hole is 4.250 inches (108.0mm) diameter.
3. The tube must be mounted by one flange only. The flange is the connection for the cathode, cathode heater return and reservoir heater return.
4. A minimum clearance of 2.500 inches (63.50mm) must be allowed below the mounting flange.

Whilst EEV has taken care to ensure the accuracy of the information contained herein it accepts no responsibility for the consequences of any use thereof and also reserves the right to change the specification of goods without notice. EEV accepts no liability beyond that set out in its standard conditions of sale in respect of infringement of third party patents arising from the use of tubes or other devices in accordance with information contained herein.



CX1175

TWO-GAP CERAMIC THYRATRON

The data to be read in conjunction with the Hydrogen Thyatron Preamble.

ABRIDGED DATA

Deuterium-filled, two-gap, high voltage thyatron with ceramic/metal envelope, featuring low jitter, firing time and drift. Suitable for switching high power at high pulse repetition rates or for switching long pulses. A reservoir operating from a separate heater supply is incorporated.

Peak forward anode voltage	80	kV max
Peak anode current (see page 2)	6000	A max
Average anode current	6.0	A max
Anode heating factor	140×10^9	V.A.p.p.s. max
Peak output power	200	MW max

GENERAL

Electrical

Cathode (connected internally to one end of heater)	oxide coated
Cathode heater voltage	$6.3 \pm 5\%$ V
Cathode heater current	40 A
Reservoir heater voltage (see note 1)	5.0 V
Reservoir heater current	10 A
Tube heating time (minimum)	15 min
Inter-electrode capacitances (approximate):	
anode to gradient grid	40 pF
gradient grid to grid 2	40 pF

Mechanical

Seated height	11.812 inches (300.0mm) max	☆
Clearance required below mounting flange	2.500 inches (63.5mm) min	
Overall diameter (mounting flange)	6.000 inches (152.4mm) nom	
Net weight	13 pounds (5.9kg) approx	
Mounting position (see note 2)	any	
Tube connections	see outline	

☆ Indicates a change

Cooling	forced-air or liquid
Forced-air	see note 3
Liquid	oil or coolant immersion
Maximum temperature of envelope	200 °C

Natural ambient cooling is usually insufficient to maintain the ceramic/metal envelope temperature below the maximum value specified above. Cooling by oil or coolant immersion is advised in view of the high voltages present. Further information is contained in the relevant section of the Preamble.

PULSE MODULATOR SERVICE

MAXIMUM AND MINIMUM RATINGS (Absolute values)

	Min	Max	
Anode			
Peak forward anode voltage (see note 4)	—	80	kV
Peak inverse anode voltage (see note 5)	—	80	kV
Peak anode current	—	6000	A
Peak anode current (pulse repetition rate limited to 60p.p.s. max)	—	8000	A
Average anode current	—	6.0	A
Rate of rise of anode current (see notes 6 and 7)	—	10 000	A/μs
Anode heating factor	—	140 x 10 ⁹	V.A.p.p.s.

Grid 2

Unloaded grid 2 drive pulse voltage (see note 8)	400	2000	V
Grid 2 pulse duration	1.0	—	μs
Rate of rise of grid 2 pulse (see note 7)	1.0	—	kV/μs
Grid 2 pulse delay	0.5	3.0	μs
Peak inverse grid 2 voltage	—	450	V
Loaded grid 2 bias voltage (see note 9)	-50	-200	V
Forward impedance of grid 2 drive circuit	50	500	Ω

Grid 1 – D.C. Primed (See note 10)

D.C. grid 1 unloaded priming voltage	75	150	V
D.C. grid 1 priming current	75	150	mA

MAXIMUM AND MINIMUM RATINGS – continued

Grid 1 – Pulsed	Min	Max	
Unloaded grid 1 drive pulse voltage (see note 8)	400	1000	V
Grid 1 pulse duration	2.0	—	μs
Rate of rise of grid 1 pulse (see note 7)	1.0	—	kV/μs
Peak inverse grid 1 voltage	—	450	V
Loaded grid 1 bias voltage			see note 11
Peak grid 1 drive current	0.5	1.5	A

Cathode

Heater voltage	6.3 ± 5%		V
Heating time	15	—	min

Reservoir

Heater voltage (see note 1)	4.5	6.5	V
Heating time	15	—	min

Environmental

Ambient temperature	−50	+90	°C
Altitude	—	10 000	ft
	—	3	km

CHARACTERISTICS

	Min	Typical	Max	
Critical d.c. anode voltage for conduction (see note 12)	—	3.0	5.0	kV
Anode delay time (see notes 12 and 13)	—	0.1	0.25	μs
Anode delay time drift (see notes 12 and 14)	—	15	50	ns
Time jitter (see note 12)	—	1.0	5.0	ns
Cathode heater current (at 6.3V)	35	40	45	A
Reservoir heater current (at 5.0V)	8.0	10	12	A

RATINGS FOR SINGLE SHOT OR CROWBAR SERVICE (See note 10)

D.C. forward anode voltage	70		kV max
Peak anode current	60 000		A max
Product of peak current and pulse length	0.2		A.s max
Repetition frequency	1 pulse per 10s		max

NOTES

1. The reservoir heater must be decoupled with a suitable capacitor to avoid damage by spike voltages. The recommended reservoir heater voltage is stamped on individual tube envelopes.
2. The tube must be mounted by means of its mounting flange.
3. An adequate flow of air must be supplied to maintain the ceramic/metal envelope temperature below the maximum rated value.
4. The maximum permissible peak forward voltage for instantaneous starting is 40kV and there must be no overshoot.
5. The peak inverse voltage including spike must not exceed 20kV for the first 250 microseconds after the anode pulse.
6. For single shot or burst mode applications this parameter can exceed 100kA/ μ s. The ultimate value which can be attained depends to a large extent upon the external circuit.
7. This rate of rise refers to that part of the leading edge of the pulse between 25% and 75% of the pulse amplitude.
8. Measured with respect to cathode. When grid 1 is pulse driven, the last 0.25 μ s of the top of the grid 1 pulse must overlap the corresponding first 0.25 μ s of the top of the delayed grid 2 pulse.
9. The tube may be operated with a loaded grid 2 bias voltage of 0 to -50V provided that care is taken to ensure that the peak grid 1 drive current is sufficiently low to prevent triode firing (tube control by the grid 1 pulse).
10. When d.c. priming is used on grid 1, a negative bias of 100 to 200V must be applied to grid 2 to ensure anode voltage hold-off. D.C. priming is recommended for pulse modulator and crowbar service.
11. D.C. negative bias voltages must not be applied to grid 1. When grid 1 is pulse driven, the potential of grid 1 may vary between -10 and +5V with respect to cathode potential during the period between the completion of recovery and the commencement of the succeeding grid pulse.
12. Typical figures are obtained on test using conditions of minimum grid drive. Improved performance can be expected by increasing grid drive.

13. The time interval between the instant at which the rising unloaded grid 2 pulse reaches 25% of its pulse amplitude and the instant when anode conduction takes place.
14. The drift in delay time over a period from 10 seconds to 10 minutes
 - after reaching full voltage.

☆ HEALTH AND SAFETY HAZARDS

EEV hydrogen thyratrons are safe to handle and operate, provided that the relevant precautions stated herein are observed. English Electric Valve Company does not accept responsibility for damage or injury resulting from the use of electronic devices it produces. Equipment manufacturers and users must ensure that adequate precautions are taken. Appropriate warning labels and notices must be provided on equipments incorporating EEV devices and in operating manuals.

High Voltage

Equipment must be designed so that personnel cannot come into contact with high voltage circuits. All high voltage circuits and terminals must be enclosed and fail-safe interlock switches must be fitted to disconnect the primary power supply and discharge all high voltage capacitors and stored charges in the electronic devices before allowing access. Interlock switches must not be bypassed to allow operation with access doors open.

X-Ray Radiation

All high voltage devices produce X-rays during operation and may require shielding. The X-ray radiation from hydrogen thyratrons is usually reduced to a safe level by enclosing the equipment with metal panels.

☆ Indicates a change

Detail of Gradient Grid Connections

3573A

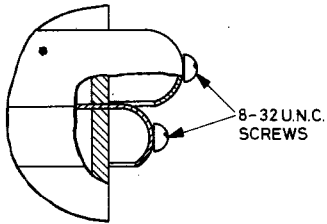

Outline Dimensions (All dimensions without limits are nominal)

Ref	Inches	Millimetres	Ref	Inches	Millimetres
☆ A	11.812 max	300.0 max	J	0.315	8.0
B	6.000	152.4	K	5.344	135.7
C	5.500	139.7	L	3.375	85.73
D	0.125	3.18	M	6.750	171.5
☆ E	2.250 min	57.15 min	N	5.875	149.2
F	4.187 max	106.3 max	P	5.875	149.2
G	7.000	177.8	Q	5.125	130.2
H	0.250	6.35			

Millimetre dimensions have been derived from inches except dimension J.

Outline Notes

1. The mounting flange is the connection for the cathode, cathode heater return and reservoir heater return.
- ☆ 2. A minimum clearance of 2.250 inches (57.15 mm) must be allowed below the mounting flange.
3. The recommended mounting hole is 4.250 inches (108mm) diameter.

☆ Indicates a change

SCHEMATIC DIAGRAM

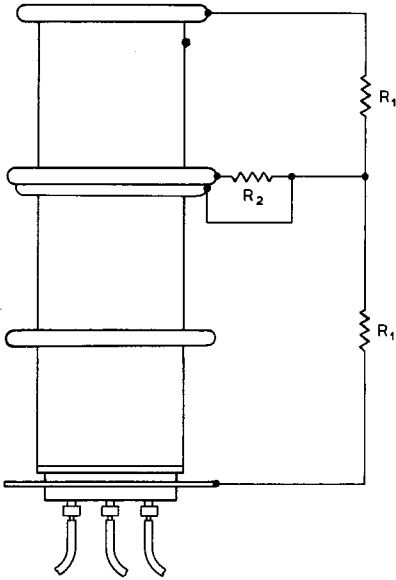

2187C

Recommended Values

$$R_1 = 10 \text{ to } 20\text{M}\Omega$$

$$R_2 = 470 \text{ to } 1000\Omega$$

Please consult EEV for alternative methods of connection.

Whilst EEV has taken care to ensure the accuracy of the information contained herein it accepts no responsibility for the consequences of any use thereof and also reserves the right to change the specification of goods without notice. EEV accepts no liability beyond that set out in its standard conditions of sale in respect of infringement of third party patents arising from the use of tubes or other devices in accordance with information contained herein.



CX1175B

TWO-GAP DOUBLE ENDED CERAMIC THYRATRON

The data to be read in conjunction with the Hydrogen Thyatron Preamble.

ABRIDGED DATA

Deuterium-filled, two-gap, double ended high voltage thyatron with ceramic/metal envelope, featuring low jitter, firing time and drift. Suitable for switching high power and for switching long pulses.

Reservoirs are incorporated, operating from separate heater supplies. The tube is electrically symmetrical, with identical cathode and grid assemblies at both ends; the flange electrode which is positive when the tube is triggered is referred to as the anode.

Peak forward anode voltage	70	kV max
Peak anode current (see page 2)	6000	A max
Average anode current	6.0	A max
Anode heating factor	120×10^9	V.A.p.p.s. max
Peak output power	175	MW max

GENERAL

Electrical

Cathodes (connected internally to one end of associated heater)		oxide coated
Cathode heater voltage (each end)	$6.3 \pm 5\%$	V
Cathode heater current (each end)	40	A
Reservoir heater voltage (each end) (see note 1)	5.0	V
Reservoir heater current (each end)	10	A
Tube heating time (minimum)	15	min
Inter-electrode capacitances (each gap)	40	pF approx

Mechanical

Seated height (flange to flange)	16.230 inches (412.2mm) nom
Clearance required below flanges	2.500 inches (63.5mm) min
Overall diameter	6.000 inches (152.4mm) nom
Net weight	17.6 pounds (8kg) approx
Mounting position (see note 2)	any
Tube connections	see outline

Cooling	forced-air or liquid
Forced-air	see note 3
Liquid	oil or coolant immersion
Maximum temperature of envelope	200 °C

Natural ambient cooling is usually insufficient to maintain the ceramic/metal envelope temperature below the maximum value specified above. Cooling by oil or coolant immersion is advised in view of the high voltages present. Further information is contained in the relevant section of the Preamble.

PULSE MODULATOR SERVICE (See note 4)

MAXIMUM AND MINIMUM RATINGS (Absolute values)

	Min	Max	
Anode			
Peak forward or inverse anode voltage (see note 5)	—	70	kV
Peak anode current	—	6000	A
Peak anode current (pulse repetition rate limited to 60p.p.s. max)	—	8000	A
Average anode current	—	6.0	A
Rate of rise of anode current (see notes 6 and 7)	—	10 000	A/μs
Anode heating factor	—	120 x 10 ⁹	V.A.p.p.s.

Grid 2

Unloaded grid 2 drive pulse voltage (see note 8)	400	2000	V
Grid 2 pulse duration	1.0	—	μs
Rate of rise of grid 2 pulse (see note 6)	1.0	—	kV/μs
Grid 2 pulse delay	0.5	3.0	μs
Peak inverse grid 2 voltage	—	450	V
Loaded grid 2 bias voltage	−50	−200	V
Forward impedance of grid 2 drive circuit	50	500	Ω

Grid 1 – D.C. Primed (see note 9)

D.C. grid 1 unloaded priming voltage	75	150	V
D.C. grid 1 priming current	25	50	mA

MAXIMUM AND MINIMUM RATINGS – continued

	Min	Max	
Grid 1 – Pulsed (see note 10)			
Unloaded grid 1 drive pulse voltage (see note 8)	400	1000	V
Grid 1 pulse duration	2.0	—	μ s
Rate of rise of grid 1 pulse (see note 6)	1.0	—	kV/ μ s
Peak inverse grid 1 voltage	—	450	V
Loaded grid 1 bias voltage			see note 11
Peak grid 1 drive current	0.5	1.5	A

Cathodes

Heater voltage		6.3 ± 5%	V
Heating time	15	—	min

Reservoirs

Heater voltage (see note 1)	3.5	6.5	V
Heating time	15	—	min

Environmental

Ambient temperature	–50	+90	°C
Altitude	—	10 000	ft
	—	3	km

CHARACTERISTICS

	Min	Typical	Max	
Critical d.c. anode voltage for conduction (see note 12)	—	3.0	5.0	kV
Anode delay time (see notes 12 and 13)	—	0.1	0.25	μ s
Anode delay time drift (see notes 12 and 14)	—	15	50	ns
Time jitter (see note 12)	—	1.0	5.0	ns
Cathode heater current (at 6.3V)	35	40	45	A
Reservoir heater current (at 5.0V)	8.0	10	12	A

RATINGS FOR SINGLE SHOT OR CROWBAR SERVICE (see note 9)

D.C. forward anode voltage	60	kV max
Peak anode current	60 000	A max
Product of peak current and pulse duration	2.0	A.s max
Repetition frequency	1 pulse per 10s	max

NOTES

1. The reservoir heaters must be decoupled with suitable capacitors to avoid damage by spike voltages. The recommended voltage for each tube is marked on the tube, and both reservoirs must be operated at the same heater voltage.
2. The tube must be mounted by one of the cathode flanges, with flexible connections to all other electrodes.
3. An adequate flow of air must be supplied to maintain the ceramic/metal envelope temperature below the maximum rated value.
4. Triggered charging techniques are recommended because the tube has a relatively long recovery time (100–200 μ s).
5. This is the maximum hold off voltage in either direction before the tube is triggered. The maximum permissible peak forward voltage for instantaneous starting is 60kV and there must be no overshoot.
6. This rate of rise refers to that part of the leading edge of the pulse between 25% and 75% of the pulse amplitude.
7. For single shot or burst mode applications this parameter can exceed 100kA/ μ s; the ultimate value which can be attained depends upon the external circuit, but the heating factor must be reduced.
8. Measured with respect to the associated cathode. The tube is triggered by pulsing the grid 2 at the negative end, while the grid 2 at the anode (positive) end is connected to its associated cathode and carries most of the forward anode current. When grid 1 is pulse driven, the last 0.25 μ s of the top of the grid 1 pulse must overlap the corresponding first 0.25 μ s of the top of the delayed grid 2 pulse.
9. When d.c. priming is used on grid 1, a negative bias of 100 to 200V must be applied to grid 2 to ensure anode voltage hold-off. D.C. priming of grid 1 at both ends is recommended for crowbar service.
10. When pulse drive is applied to the triggered end of the tube, the grid 1 at the anode (positive) end will normally be d.c. primed.
11. D.C. negative bias voltages must not be applied to grid 1. When grid 1 is pulse driven, the potential of grid 1 may vary between –10 and +5V with respect to cathode during the period between the completion of recovery and the start of the next grid pulse.

12. Typical figures are obtained on test using conditions of minimum grid drive. Improved performance can be expected with increased grid drive.
13. The time interval between the instant at which the rising unloaded grid 2 pulse reaches 25% of its pulse amplitude and the instant when anode conduction takes place.
14. The drift in delay time over a period from 10 seconds to 10 minutes after reaching full voltage.

X-RAY WARNING

X-rays may be emitted by the CX1175B but the radiation is usually reduced to a safe level by the metal surrounds and panels of the equipment in which the tube operates.

SCHEMATIC DIAGRAM

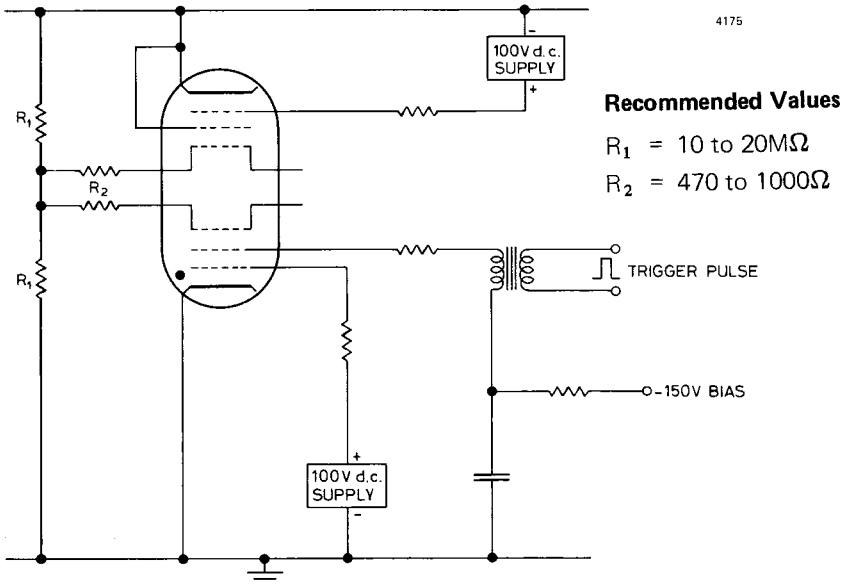

OUTLINE

4181

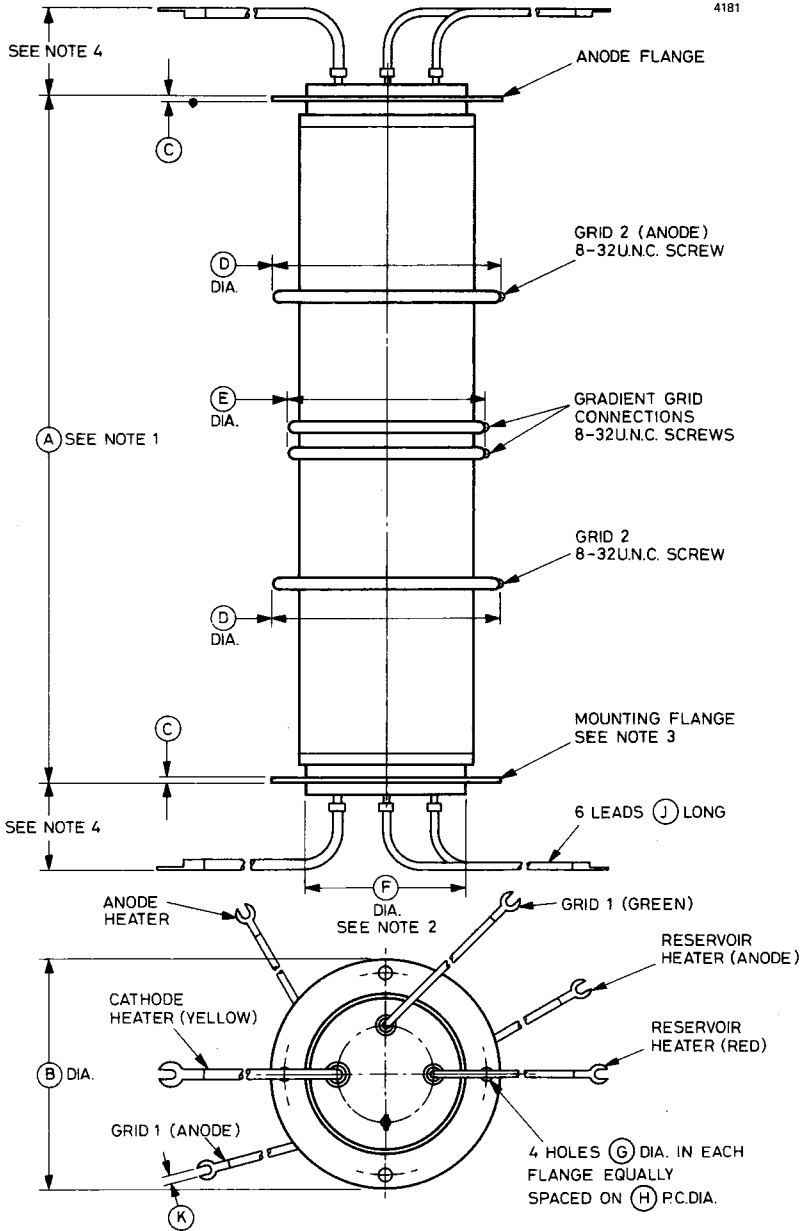

Detail of Gradient Grid Connections

3573A

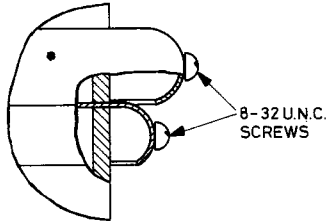

Outline Dimensions (All dimensions without limits are nominal)

Ref	Inches	Millimetres
A	16.230 ± 0.100	412.24 ± 2.54
B	6.000	152.4
C	0.125	3.18
D	5.875	149.2
E	5.125	130.2
F	4.187 max	106.3 max
G	0.315	8.0
H	5.344	135.7
J	7.000	177.8
K	0.250	6.35

Millimetre dimensions have been derived from inches.

Outline Notes

1. The two flanges will be parallel within 0.059 inch (1.5mm).
2. The recommended mounting hole is 4.250 inches (108.0mm) diameter.
3. The tube must be mounted by one flange only. The flange is the connection for the cathode, cathode heater return and reservoir heater return.
4. A minimum clearance of 2.500 inches (63.50mm) must be allowed below the mounting flange.

Whilst EEV has taken care to ensure the accuracy of the information contained herein it accepts no responsibility for the consequences of any use thereof and also reserves the right to change the specification of goods without notice. EEV accepts no liability beyond that set out in its standard conditions of sale in respect of infringement of third party patents arising from the use of tubes or other devices in accordance with information contained herein.



HYDROGEN THYRATRON

The data to be read in conjunction with the Hydrogen Thyatron Preamble.

ABRIDGED DATA

Hydrogen-filled tetrode thyatron with ceramic/metal envelope, featuring low jitter and low anode delay time drift. Suitable for use at high pulse repetition rates and in applications requiring ruggedness and compactness. A hydrogen reservoir with separate heater supply lead is incorporated.

Peak forward anode voltage	12	kV max
Peak anode current	150	A max
Average anode current	200	mA max
Anode heating factor	4.0×10^9	V.A.p.p.s. max
Peak output power	0.9	MW max

GENERAL

Electrical

Cathode (connected internally to one end of heater)	oxide coated
Cathode heater voltage	$6.3 \pm 7\frac{1}{2}\%$ V
Cathode heater current	4.5 A
Reservoir heater voltage (see note 1)	$6.3 \pm 7\frac{1}{2}\%$ V
Reservoir heater current	2.0 A
Tube heating time (minimum) (see note 2)	3.0 min

Mechanical

Seated height	2.400 inches (60.96mm) max
Clearance required below mounting flange	1.125 inches (28.58mm) min
Overall diameter (mounting flange)	1.875 inches (47.63mm) nom
Net weight	6 ounces (170g) approx
Mounting position (see note 3)	any
Tube connections	see outline

Cooling natural, forced-air or liquid

Where natural cooling is insufficient to maintain the envelope temperatures below the specified rated values, cooling by forced-air, or by oil or coolant immersion may be used.

The temperature of the anode terminal and the base, measured at the points indicated on the outline drawing, must not exceed the values specified below.

Anode terminal	250	°C max
Base	220	°C max

PULSE MODULATOR SERVICE

MAXIMUM AND MINIMUM RATINGS (Absolute values)

	Min	Max	
Anode			
Peak forward anode voltage (see note 4)	—	12	kV
Peak inverse anode voltage (see note 5)	—	12	kV
Peak anode current	—	150	A
Average anode current	—	200	mA
Rate of rise of anode current (see note 6)	—	2000	A/ μ s
Anode heating factor	—	4.0×10^9	V.A.p.p.s.

Grid 2

Unloaded grid 2 drive pulse voltage (see note 7)	200	2000	V
Grid 2 pulse duration	1.0	—	μ s
Rate of rise of grid 2 pulse	1.0	—	kV/ μ s
Grid 2 pulse delay	0.5	3.0	μ s
Peak inverse grid 2 voltage	—	200	V
On load grid 2 bias voltage (see note 8)	0	–200	V
Forward impedance of grid 2 drive circuit	100	2000	Ω

Grid 1 – D.C. Primed (See note 9)

D.C. grid 1 unloaded priming voltage	75	150	V
D.C. grid 1 priming current	50	100	mA

Grid 1 – Pulsed

Unloaded grid 1 drive pulse voltage (see note 7)	300	2000	V
Grid 1 pulse duration	2.0	—	μ s
Rate of rise of grid 1 pulse	1.0	—	kV/ μ s
Peak inverse grid 1 voltage	—	200	V
On load grid 1 bias voltage			see note 10
Peak grid 1 drive current	150	500	mA

Cathode

Heater voltage	6.3 ± 7½%	V
Heating time (see note 2)	3.0	min

Reservoir

Heater voltage	6.3 ± 7½%	V
Heating time (see note 2)	3.0	min

Environmental (See Note 11)

Ambient temperature	-55	+130	°C
Altitude	—	10 000	ft
	—	3	km

CHARACTERISTICS

	Min	Typical	Max	
Critical d.c. anode voltage for conduction (see note 12)	—	200	300	V
Anode delay time (see notes 12 and 13)	—	0.12	0.3	µs
Anode delay time drift (see notes 12 and 14)	—	10	50	ns
Time jitter (see note 12)	—	1.0	5.0	ns
Recovery time		see note 15 and curves		
Heater and reservoir current (at 6.3V)	5.0	6.5	8.0	A

NOTES

1. The reservoir heater supply must be decoupled with a suitable capacitor to avoid damage to the reservoir heater by spike voltages.
2. For ambient temperatures between -20°C and -55°C the tube heating time with 6.3V on the cathode and reservoir heaters is 5 minutes. The tube heating time may be reduced to 90 seconds minimum at ambient temperatures down to 0°C by applying 7.5V to the cathode and reservoir heaters. After warm-up the heater voltages must be reduced to 6.3V.

3. The tube must be mounted by means of its mounting flange.
4. The maximum permissible peak forward voltage for instantaneous starting is 10kV, and there must be no overshoot.
5. The peak inverse voltage (exclusive of a spike of 50 nanoseconds maximum* duration) must not exceed 6.0kV for the first 25 microseconds after the anode pulse.
6. This rate of rise refers to that part of the leading edge of the pulse between 25% and 75% of the pulse amplitude. Stray anode capacitance should be kept to a minimum and not allowed to exceed 10pF.
7. Measured with respect to cathode. When grid 1 is pulse driven, the last 0.25 μ s of the top of the grid 1 pulse must overlap the corresponding first 0.25 μ s of the top of the delayed grid 2 pulse.
8. The tube may be operated with an on-load grid 2 bias voltage of 0 to -50V provided that care is taken to ensure that the peak grid 1 drive current is sufficiently low to prevent triode firing (tube control by the grid 1 pulse).
9. When d.c. priming is used on grid 1, a negative bias of 100 to 200V must be applied to grid 2 to ensure anode voltage hold-off.
10. D.C. negative bias voltages must not be applied to grid 1. When grid 1 is pulse driven, the d.c. potential of grid 1 may vary between -10V and +5V with respect to cathode potential during the period between the completion of recovery and the commencement of the succeeding grid pulse.
11. To ensure a high standard of ruggedness, all tubes are subjected to the following tests. After each mechanical test all the tubes must then satisfy all electrical tests.
 - (a) Vibration – The tubes are vibrated at 50Hz with acceleration of 10g for one minute in the direction of the cathode axis and then in one direction perpendicular to the cathode axis. See note 3.
 - (b) Recovery Time – The tubes are tested for recovery at zero grid 2 bias voltage with a maximum limit of 50 μ s.

The tubes are subjected to the following tests on a sample basis.

- (c) Operation under Vibration – The tubes are vibrated at 10g in each of three planes at a sweep rate of one octave per minute from 20 to 2000 to 20Hz, under normal operating conditions. See note 3.

- (d) Survival under Vibration and Heater Cycling – The tubes are vibrated at 10g at a sweep rate of one octave per minute from 5 to 2000Hz for 70 hours in each plane together with heater cycling with a 10 minute on/off cycle. See note 3.
 - (e) Long Duration Shock – The tubes are tested at 125g for ten milliseconds with two blows in each plane. See note 3.
 - (f) High Temperature Test – The tubes are tested at a base temperature of 220°C and an anode temperature of 250°C under normal operating conditions for 5 hours. This implies an ambient temperature of 130°C.
 - (g) Low Temperature Instant Start – The tubes are cooled to –20°C and subjected to a 3-minute warm up period with 5.8V on the heater. The tubes must withstand a snap start at 10kV and operate satisfactorily.
 - (h) Standby Life – The tubes are run with 6.3V heater voltage applied for 500 hours.
12. Typical figures are obtained on test using conditions of minimum grid drive. Improved performance can be expected by increasing the grid drive.
 13. The time interval between the instant when the unloaded grid 2 voltage passes cathode potential and the instant when anode conduction takes place.
 14. The drift in delay time over a period from 10 seconds to 10 minutes after reaching full voltage.
 15. The recovery characteristics are controlled on a sampling basis.

X-RAY WARNING

X-rays are emitted by the CX1177 from the region of the anode, but the radiation is usually reduced to a safe level by the metal panels of the equipment in which the tube operates.

MAXIMUM RECOVERY CHARACTERISTICS

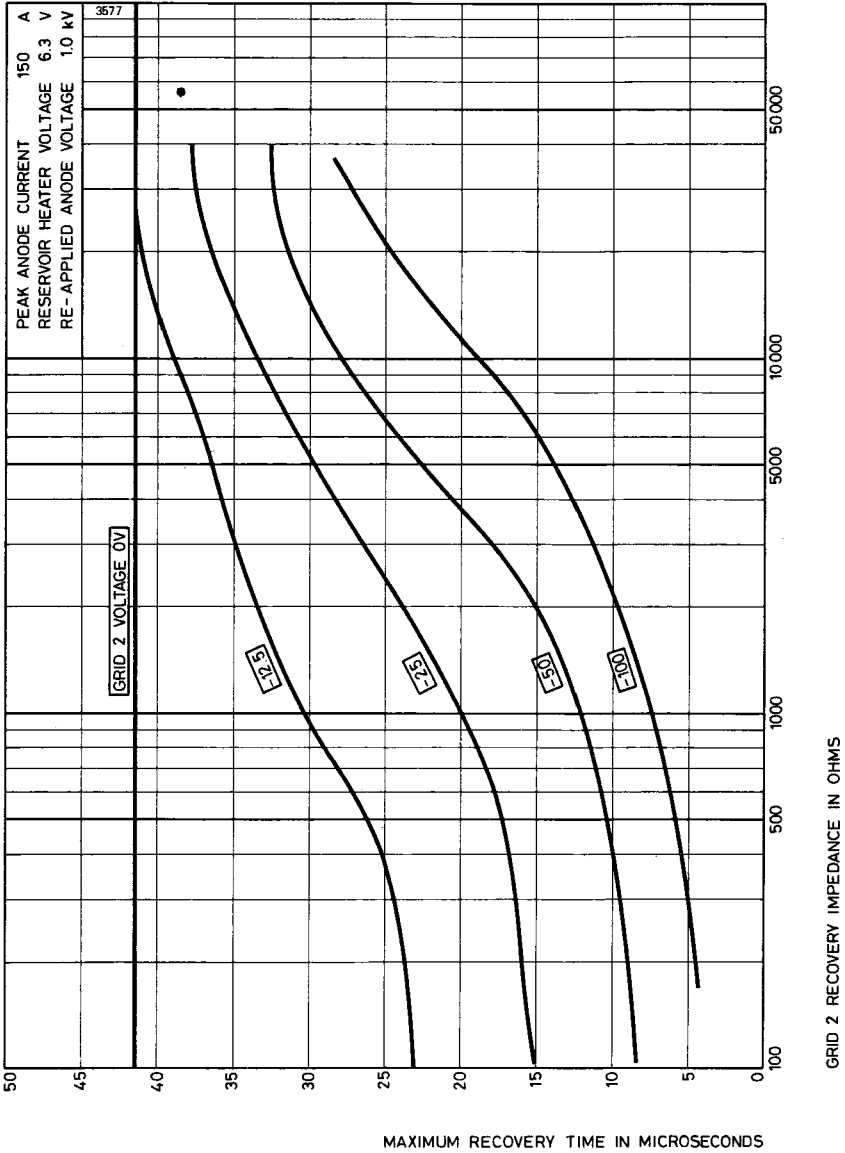

OUTLINE (See page 8 for Outline Notes and Dimensions)

2471A

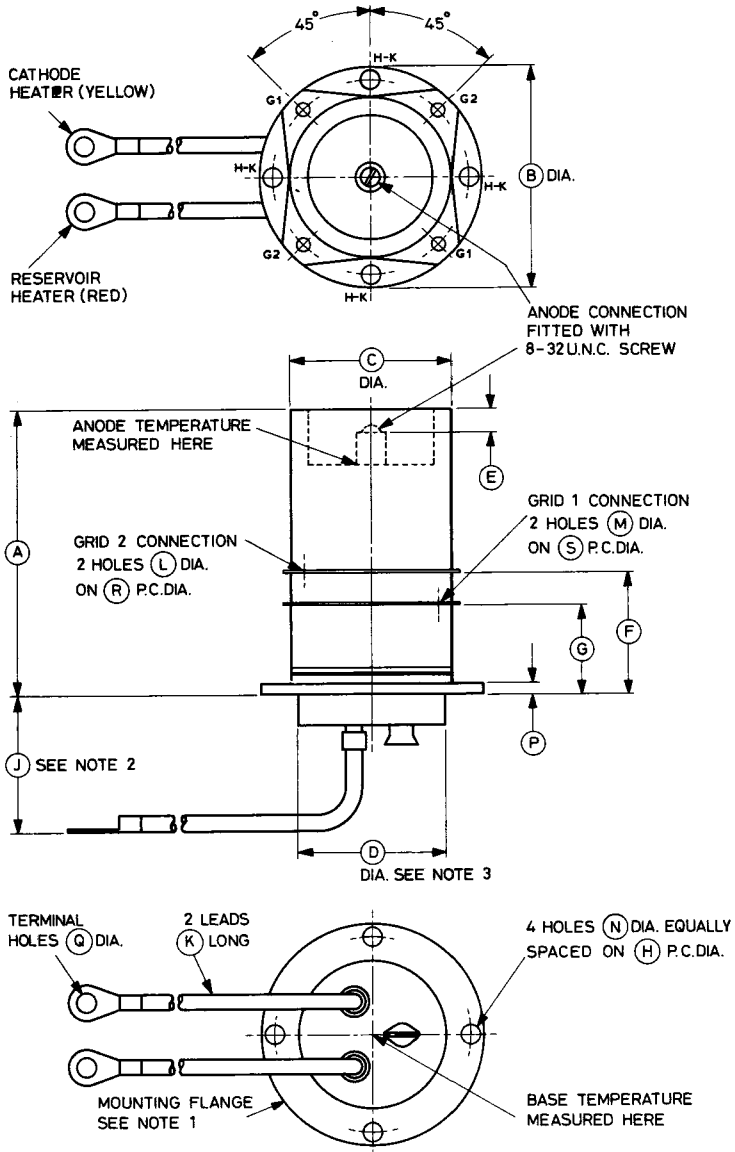

Outline Dimensions (All dimensions without limits are nominal)

Ref	Inches	Millimetres
A	2.400 max	60.96 max
B	1.875	47.63
C	1.375	34.93
D	1.250	31.75
E	0.197 \pm 0.030	5.00 \pm 0.76
F	1.021	25.93
G	0.750	19.05
H	1.656 \pm 0.010	42.06 \pm 0.25
J	1.125 min	28.58 min
K	6.000	152.4
L	0.118	3.00
M	0.118	3.00
N	0.156	3.96
P	0.100	2.54
Q	0.150	3.81
R	1.625	41.28
S	1.625	41.28

Millimetre dimensions have been derived from inches.

Outline Notes

1. The mounting flange is the connection for the cathode, cathode heater return and reservoir heater return.
2. A minimum clearance of 1.125 inches (28.58mm) must be allowed below the mounting flange.
3. The recommended mounting hole is 1.312 inches (33.3mm) diameter.



CX1180

HYDROGEN-FILLED CERAMIC THYRATRON

The data to be read in conjunction with the Hydrogen Thyatron Preamble.

ABRIDGED DATA

Hydrogen-filled tetrode thyatron with ceramic/metal envelope, featuring low jitter, firing time and drift. Suitable for switching high power at high pulse repetition rates or for switching long pulses. A hydrogen reservoir operating from the heater supply is incorporated.

Peak forward anode voltage	25	kV max
Peak anode current	1000	A max
Average anode current	1.25	A max
Anode heating factor	12.5×10^9	V.A.p.p.s. max
Peak output power	12.5	MW max

GENERAL

Electrical

Cathode (connected internally to one end of heater)	oxide coated
Cathode heater voltage	$6.3 \pm 5\%$ V
Cathode heater current	11 A
Reservoir heater voltage (see note 1)	$6.3 \pm 5\%$ V
Reservoir heater current	6.0 A
Tube heating time (minimum)	5.0 min
Anode to grid 2 capacitance	15 to 20 pF

Mechanical

Seated height	4.875 inches (123.8mm) max
Clearance required below mounting flange	1.500 inches (38.1mm) min
Overall diameter (mounting flange)	3.500 inches (88.9mm) nom
Net weight	2¼ pounds (1.0kg) approx
Mounting position (see note 2)	any
Tube connections	see outline

Cooling natural, forced-air or liquid

Where natural cooling is insufficient to maintain the envelope temperature below the specified rated value, cooling by forced-air or by oil or coolant immersion may be used.

Forced-air see note 3

Liquid oil or coolant immersion

Maximum temperature of envelope 200 °C

Further information is contained in the relevant section of the Preamble.

PULSE MODULATOR SERVICE

MAXIMUM AND MINIMUM RATINGS (Absolute values)

	Min	Max	
Anode			
Peak forward anode voltage (see note 4)	—	25	kV
Peak inverse anode voltage (see note 5)	—	25	kV
Peak anode current	—	1000	A
Average anode current	—	1.25	A
Rate of rise of anode current (see notes 6 and 7)	—	5000	A/ μ s
Anode heating factor	—	12.5×10^9	V.A.p.p.s.

Grid 2

Unloaded grid 2 drive pulse voltage (see note 8)	200	1000	V
Grid 2 pulse duration	1.0	—	μ s
Rate of rise of grid 2 pulse (see note 7)	1.0	—	kV/ μ s
Grid 2 pulse delay	0.5	3.0	μ s
Peak inverse grid 2 voltage	—	450	V
Loaded grid 2 bias voltage (see note 9)	-50	-200	V
Forward impedance of grid 2 drive circuit	50	1000	Ω

Grid 1 — D.C. Primed (See note 10)

D.C. grid 1 unloaded priming voltage	75	150	V
D.C. grid 1 priming current	50	150	mA

MAXIMUM AND MINIMUM RATINGS — continued

Grid 1 — Pulsed

	Min	Max	
Unloaded grid 1 drive pulse voltage (see note 8)	300	1000	V
Grid 1 pulse duration	2.0	—	μ s
Rate of rise of grid 1 pulse (see note 7)	1.0	—	kV/ μ s
Peak inverse grid 1 voltage	—	450	V
Loaded grid 1 bias voltage	—	—	see note 11
Peak grid 1 drive current	0.3	1.0	A

Cathode

Heater voltage	6.3 \pm 5%		V
Heating time	5.0	—	min

Reservoir

Heater voltage (see note 1)	6.3 \pm 5%		V
Heating time	5.0	—	min

Environmental

Ambient temperature	—50	+90	$^{\circ}$ C
Altitude	—	10 000	ft
	—	3	km

CHARACTERISTICS

	Min	Typical	Max	
Critical d.c. anode voltage for conduction (see note 12)	—	0.3	1.0	kV
Anode delay time (see notes 12 and 13)	—	0.1	0.25	μ s
Anode delay time drift (see notes 12 and 14)	—	20	50	ns
Time jitter (see note 12)	—	1.0	5.0	ns
Cathode heater current (at 6.3V)	9.0	11	13	A
Reservoir heater current (at 6.3V)	4.0	6.0	8.0	A

RATINGS FOR SINGLE SHOT OR CROWBAR SERVICE (See note 10)

D.C. forward anode voltage	25	kV max
Peak anode current	5000	A max
Product of peak current and pulse length	0.2	A.s max
Repetition frequency	1 pulse per 10s	max

NOTES

1. The reservoir heater supply must be obtained either from the cathode heater supply or if a separate supply is used it must be decoupled to avoid damage to the reservoir.
2. The tube must be mounted by means of its mounting flange.
3. An adequate flow of air must be supplied to maintain the ceramic/metal envelope temperature below the maximum rated value.
4. The maximum permissible peak forward voltage for instantaneous starting is 20kV and there must be no overshoot.
5. The peak inverse voltage including spike must not exceed 10kV for the first 25 microseconds after the anode pulse.
6. For single shot or burst mode applications this parameter can exceed 100kA/ μ s. The ultimate value which can be attained depends to a large extent upon the external circuit.
7. This rate of rise refers to that part of the leading edge of the pulse between 25% and 75% of the pulse amplitude.
8. Measured with respect to cathode. When grid 1 is pulse driven, the last 0.25 μ s of the top of the grid 1 pulse must overlap the corresponding first 0.25 μ s of the top of the delayed grid 2 pulse.
9. The tube may be operated with a loaded grid 2 bias voltage of 0 to -50V provided that care is taken to ensure that the peak grid 1 drive current is sufficiently low to prevent triode firing (tube control by the grid 1 pulse).
10. When d.c. priming is used on grid 1, a negative bias of 100 to 200V must be applied to grid 2 to ensure anode voltage hold-off. D.C. priming is recommended for pulse modulator and crowbar service.
11. D.C. negative bias voltages must not be applied to grid 1. When grid 1 is pulse driven, the potential of grid 1 may vary between -10 and +5V with respect to cathode potential during the period between the completion of recovery and the commencement of the succeeding grid pulse.
12. Typical figures are obtained on test using conditions of minimum grid drive. Improved performance can be expected by increasing grid drive.

13. The time interval between the instant when the unloaded grid 2 voltage passes cathode potential and the instant when anode conduction takes place.
14. The drift in delay time over a period from 10 seconds to 10 minutes
 - after reaching full voltage.

X-RAY WARNING

X-rays may be emitted by the CX1180 but the radiation is usually reduced to a safe level by the metal panels of the equipment in which the tube operates.

OUTLINE

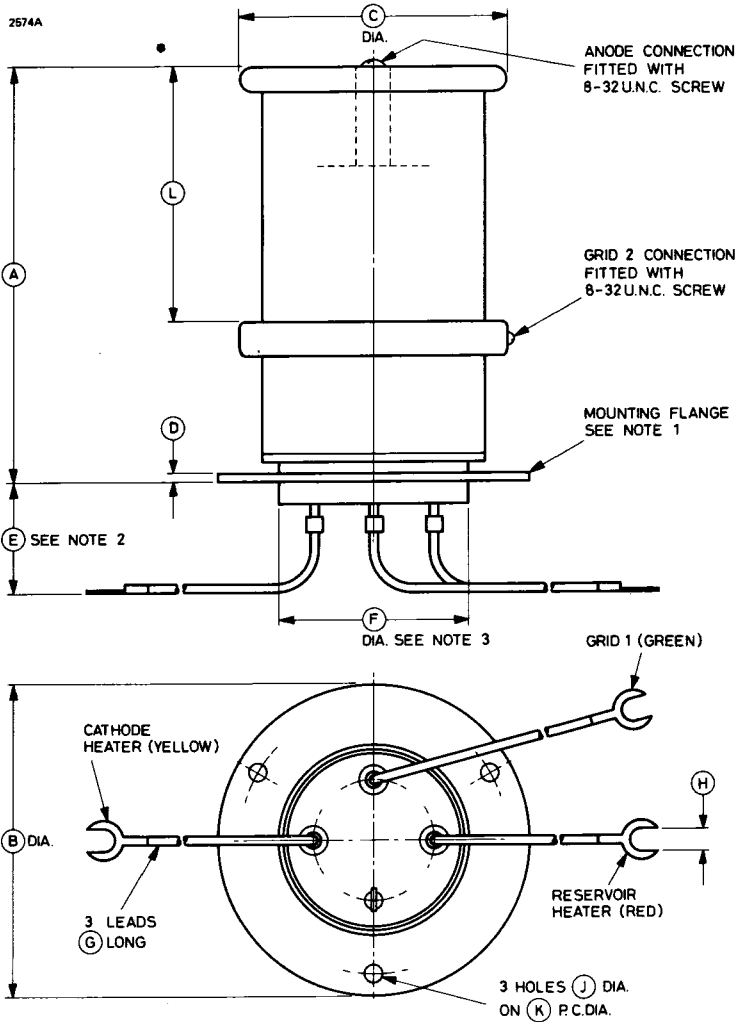

Outline Dimensions (All dimensions without limits are nominal)

Ref	Inches	Millimetres
A	4.875 max	123.8 max
B	3.500	88.90
C	3.062	77.77
D	0.100	2.54
E	1.500 min	38.10 min
F	2.125 max	53.98 max
G	6.000	152.4
H	0.250	6.35
J	0.197	5.00
K	3.000	76.20
L	2.875	73.03

Millimetre dimensions have been derived from inches except dimension J.

Outline Notes

1. The mounting flange is the connection for the cathode, cathode heater return and reservoir heater return.
2. A minimum clearance of 1.500 inches (38.10mm) must be allowed below the mounting flange.
3. The recommended mounting hole is 2.187 inches (55.55mm) diameter.



CX1191

HYDROGEN THYRATRON

The data to be read in conjunction with the Hydrogen Thyatron Preamble.

ABRIDGED DATA

Hydrogen-filled tetrode thyatron, featuring fast recovery time and ruggedized construction, suitable for use in airborne or mobile military radar systems. It is used for switching peak powers up to 3.2MW at high repetition rates under a wide range of operating conditions. It has a rugged, internally connected reservoir and under normal conditions the CX1191 will give a life of at least 3000 hours. Samples are subjected to extensive environmental test procedures including vibration at 2g from 50 to 500Hz.

Peak forward anode voltage	16	kV max
Peak anode current	400	A max
Average anode current	0.4	A max
Anode heating factor	5.0×10^9	V.A.p.p.s. max
Peak output power	3.2	MW max

GENERAL

Electrical

Cathode (connected internally to one end of heater)		oxide coated
Heater voltage	$6.3 \pm 7\frac{1}{2}\%$	V
Heater current	12.5	A
Tube heating time (minimum) (see note 1)	2.0	min
Inter-electrode capacitances (approximate):		
anode to grid 2 (grid 1 and cathode not connected)	9.0	pF
anode to grid 1 (grid 2 and cathode not connected)	4.5	pF
anode to cathode (grid 1 and grid 2 not connected)	18	pF

Mechanical

Overall length	8.250 inches (209.6mm) max
Overall diameter	2.562 inches (65.1mm) max
Net weight	12 ounces (340g) approx
Mounting position (see note 2)	any
Base	B4D, bayonet
Top cap	B.S.448-CT3

Cooling	natural
--------------------------	---------

PULSE MODULATOR SERVICE

MAXIMUM AND MINIMUM RATINGS (Absolute values)

	Min	Max	
Anode			
Peak forward anode voltage (see note 1)	—	16	kV
Peak inverse anode voltage (see note 3)	—	5.0	kV
Peak anode current	—	400	A
Average anode current	—	0.4	A
Rate of rise of anode current (see note 4)	—	2500	A/ μ s
Anode heating factor	—	5.0×10^9	V.A.p.p.s.

Grid 2

Unloaded grid 2 drive pulse voltage (see note 5)	200	750	V
Grid 2 pulse duration	1.0	—	μ s
Rate of rise of grid 2 pulse (see note 4)	1.0	—	kV/ μ s
Grid 2 pulse delay	0.5	3.0	μ s
Peak inverse grid 2 voltage	—	200	V
Loaded grid 2 bias voltage	-50	-120	V
Forward impedance of grid 2 drive circuit	100	1000	Ω

Grid 1 — D.C. Primed (See note 6)

D.C. grid 1 unloaded priming voltage	75	150	V
D.C. grid 1 priming current	50	100	mA

Grid 1 — Pulsed

Unloaded grid 1 drive pulse voltage (see note 5)	300	750	V
Grid 1 pulse duration	2.0	—	μ s
Rate of rise of grid 1 pulse (see note 4)	1.0	—	kV/ μ s
Peak inverse grid 1 voltage	—	200	V
Loaded grid 1 bias voltage	—	—	see note 7
Peak grid 1 drive current	0.3	1.0	A

Cathode

Heater voltage	$6.3 \pm 7\frac{1}{2}\%$	—	V
Tube heating time (see note 1)	2.0	—	min

Environmental

Environmental performance	—	—	see note 8
Ambient temperature	-55	+90	$^{\circ}$ C
Altitude	—	10 000	ft
	—	3	km

CHARACTERISTICS

	Min	Typical	Max	
Critical d.c. anode voltage for conduction (see note 9)	—	0.3	1.0	kV
Anode delay time (see notes 9 and 10)	—	0.15	0.25	μ s
Anode delay time drift (see notes 9, 11 and 12)	—	20	50	ns
Time jitter (see notes 9 and 12)	—	1.0	5.0	ns
Recovery time				see note 13 and curves
Heater current (at 6.3V)	11	12.5	13	A

RATINGS FOR SINGLE SHOT OR CROWBAR SERVICE (See note 6)

D.C. forward anode voltage	15	kV max
Peak anode current	5000	A max
Product of peak current and pulse length	0.2	A.s max
Repetition frequency	1 pulse per 10s	max

NOTES

- For instantaneous starting applications where the anode voltage exceeds 12kV, the minimum cathode heating time is 3 minutes. The maximum permissible peak forward voltage for instantaneous starting is 16.0kV, and there must be no overshoot.
- Clamping is only permissible by the base.
- The peak inverse voltage exclusive of a spike of 1 microsecond maximum duration and 16kV maximum amplitude must not exceed 10kV for the first 5 microseconds after the anode pulse and must not exceed 5.0kV thereafter.
- The rate of rise refers to that part of the leading edge of the pulse between 25% and 75% of the pulse amplitude.
- Measured with respect to cathode. In certain cases the maximum drive pulse voltage may be exceeded without damage to the tube; a maximum value of 2.5kV is then recommended. When grid 1 is pulse driven, the last 0.25 μ s of the top of the grid 1 pulse must overlap the corresponding first 0.25 μ s of the top of the delayed grid 2 pulse.

6. When d.c. priming is used on grid 1, a negative bias of 100 to 200V must be applied to grid 2 to ensure anode voltage hold-off. D.C. priming is recommended for pulse modulator and crowbar service.
7. D.C. negative bias voltages must not be applied to grid 1. When grid 1 is pulse driven, the potential of grid 1 may vary between -10 and $+5V$ with respect to cathode potential during the period between the completion of recovery and the commencement of the succeeding grid pulse.
8. All tubes are subjected to an acceleration of 10g at 50Hz before testing. In addition, samples are tested under the following conditions:
 - (a) **Linear Acceleration** 12g (min) is applied and maintained for 1 minute at right angles to and in each direction along the major axis of the tube. A heater voltage of 6.3V is applied during the test.
 - (b) **Resonance Search** Vibration is applied in two mutually perpendicular directions, one of which is parallel to the longitudinal axis of the tube. The frequency is swept at a rate not exceeding one octave per minute between 10 and 150Hz, with accelerations of 2g (min). All resonances detectable visually or electrically are noted for information and also for use in test (c). Normal operating voltages are applied during the test.
 - (c) **Vibration Fatigue** Each tube is subjected to vibration for two periods of ten hours. In one period the direction of vibration is parallel to the longitudinal axis of the tube, and in the other the direction is perpendicular to the longitudinal axis of the tube. An acceleration of 2g is used and the frequency is that of the strongest resonance detected during the resonance search. If no resonances were detected in the search, then a frequency of 150Hz is used. A heater voltage of 6.3V is applied during the test.

Tubes must pass operational tests after the above procedure has been completed.

In addition to operational testing at a pulse repetition rate of 1000p.p.s. on all tubes, an additional test at 6400p.p.s. is performed on a sampling basis.

9. Typical figures are obtained on test using conditions of minimum grid drive. Improved performance can be expected by increasing the grid drive.
10. The time interval between the instant when the open circuit grid 2 voltage passes cathode potential and the instant when anode conduction takes place.
11. The drift in delay time over a period from 10 seconds to 10 minutes after reaching full voltage.
12. For equipment where jitter and anode delay time drift are not important, the tube may be triggered by applying a single pulse to grid 2 and connecting grid 1 to grid 2 via a 100pF capacitor shunted by a 10M Ω resistor.
13. The recovery characteristics are controlled on a sampling basis.

X-RAY WARNING

X-rays are emitted by the CX1191 from the region of the anode, but the radiation is usually reduced to a safe level by the metal panels of the equipment in which the tube operates.

MAXIMUM RECOVERY CHARACTERISTICS

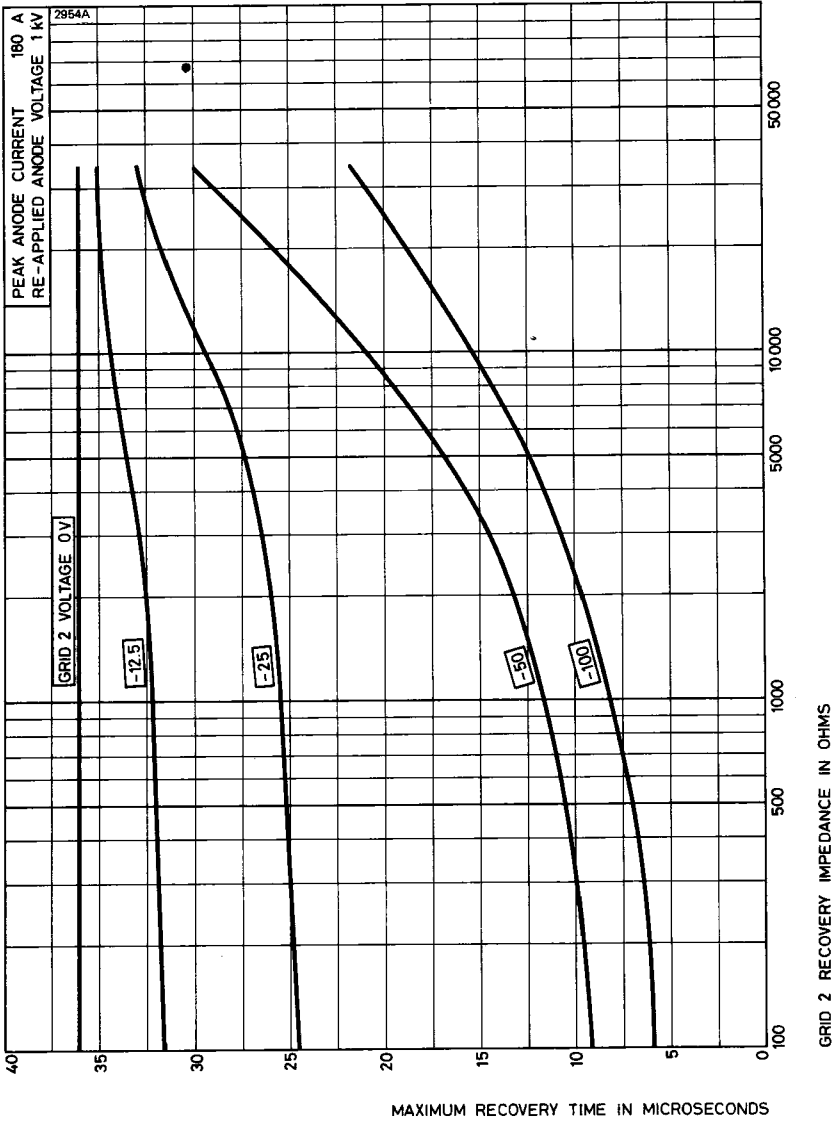

OUTLINE (All dimensions without limits are nominal)

2963

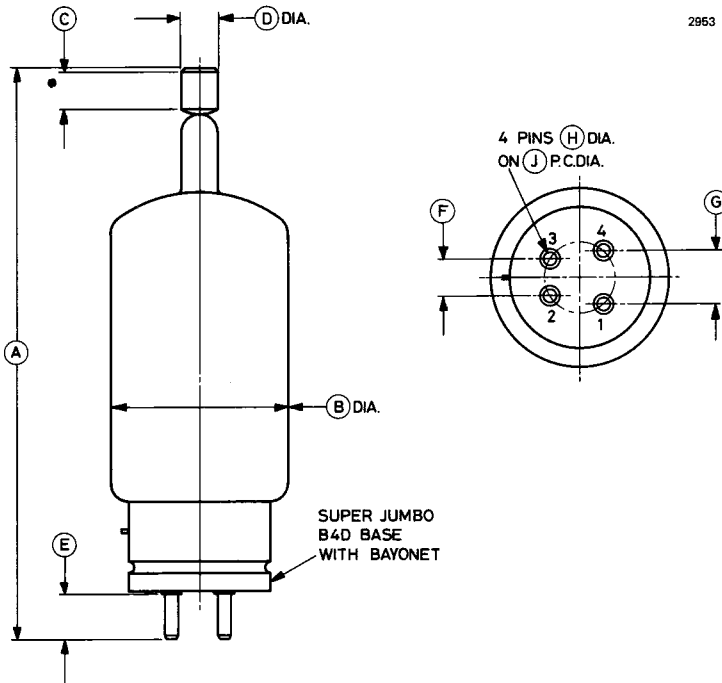

Ref	Inches	Millimetres	Pin	Element
A	8.000 ± 0.250	203.2 ± 6.4	1	Grid 1
B	2.562 max	65.08 max	2	Heater, cathode
C	0.500 min	12.70 min	3	Heater
D	0.566 ± 0.007	14.38 ± 0.18	4	Grid 2
E	0.625	15.88	Top cap	Anode
F	0.562	14.28		
G	0.750	19.05		
H	0.187 ± 0.003	4.750 ± 0.076		
J	1.000	25.40		

Millimetre dimensions have been derived from inches.



HYDROGEN THYRATRON

The data to be read in conjunction with the Hydrogen Thyatron Preamble.

ABRIDGED DATA

Hydrogen-filled tetrode thyatron, featuring fast recovery time and ruggedized construction, suitable for use in airborne or mobile military radar systems. It is used for switching peak powers up to 6.25MW at high repetition rates under a wide range of operating conditions. It has a rugged, internally connected reservoir. Samples are subjected to extensive environmental test procedures including vibration at 2g from 50 to 500Hz.

Peak forward anode voltage	25	kV max
Peak anode current	500	A max
Average anode current	0.5	A max
Anode heating factor	6.25×10^9	V.A.p.p.s. max
Peak output power	6.25	MW max

GENERAL

Electrical

Cathode (connected internally to one end of heater)	oxide coated
Heater voltage	$6.3 \pm 7\%$ V
Heater current	12.5 A
Tube heating time (minimum) (see note 1)	3.0 min
Inter-electrode capacitances (approximate):	
anode to grid 2 (grid 1 and cathode not connected)	9.0 pF
anode to grid 1 (grid 2 and cathode not connected)	4.5 pF
anode to cathode (grid 1 and grid 2 not connected)	18 pF

Mechanical

Overall length	8.250 inches (209.6mm) max
Overall diameter	2.562 inches (65.1mm) max
Net weight	12 ounces (340g) approx
Mounting position (see note 2)	any
Base	B4D, bayonet
Top cap	B.S.448-CT3

Cooling	natural
-------------------	---------

PULSE MODULATOR SERVICE

MAXIMUM AND MINIMUM RATINGS (Absolute values)

	Min	Max	
Anode			
Peak forward anode voltage (see note 1)	—	25	kV
Peak inverse anode voltage (see note 3)	—	25	kV
Peak anode current	—	500	A
Average anode current	—	0.5	A
Rate of rise of anode current (see note 4)	—	2500	A/ μ s
Anode heating factor	—	6.25×10^9	V.A.p.p.s.

Grid 2

Unloaded grid 2 drive pulse voltage (see note 5)	200	750	V
Grid 2 pulse duration	1.0	—	μ s
Rate of rise of grid 2 pulse (see note 4)	1.0	—	kV/ μ s
Grid 2 pulse delay	0.5	3.0	μ s
Peak inverse grid 2 voltage	—	200	V
Loaded grid 2 bias voltage	-50	-120	V
Forward impedance of grid 2 drive circuit	100	1000	Ω

Grid 1 — D.C. Primed (See note 6)

D.C. grid 1 unloaded priming voltage	75	150	V
D.C. grid 1 priming current	50	100	mA

Grid 1 — Pulsed

Unloaded grid 1 drive pulse voltage (see note 5)	300	750	V
Grid 1 pulse duration	2.0	—	μ s
Rate of rise of grid 1 pulse (see note 4)	1.0	—	kV/ μ s
Peak inverse grid 1 voltage	—	200	V
Loaded grid 1 bias voltage	—	—	see note 7
Peak grid 1 drive current	0.3	1.0	A

Cathode

Heater voltage	$6.3 \pm 7\frac{1}{2}\%$	—	V
Tube heating time (see note 1)	3.0	—	min

Environmental

Environmental performance	—	—	see note 8
Ambient temperature	-55	+90	$^{\circ}$ C
Altitude	—	10 000	ft
	—	3	km

CHARACTERISTICS

	Min	Typical	Max	
Critical d.c. anode voltage for conduction (see note 9)	—	0.3	1.0	kV
Anode delay time (see notes 9 and 10)	—	0.15	0.25	μ s
Anode delay time drift (see notes 9, 11 and 12)	—	20	50	ns
Time jitter (see notes 9 and 12)	—	1.0	5.0	ns
Heater current (at 6.3V)	11	12.5	13	A

RATINGS FOR SINGLE SHOT OR CROWBAR SERVICE (See note 6)

D.C. forward anode voltage	25	kV max
Peak anode current	5000	A max
Product of peak current and pulse duration	0.2	A.s max
Repetition frequency	1 pulse per 10s	max

NOTES

1. The maximum permissible peak forward voltage for instantaneous starting is 20kV and there must be no overshoot. For single shot and crowbar applications, each tube is tested to withstand 25kV at 6.3V heater voltage, with 100mA grid 1 drive current and -100 V grid 2 bias voltage.
2. Clamping is only permissible by the base.
3. For pulsed operation, the peak inverse anode voltage exclusive of a spike of 0.05 microsecond duration must not exceed 10kV during the first 25 microseconds after the pulse.
4. The rate of rise refers to that part of the leading edge of the pulse between 25% and 75% of the pulse amplitude.
5. Measured with respect to cathode. In certain cases the maximum drive pulse voltage may be exceeded without damage to the tube; a maximum value of 2.5kV is then recommended. When grid 1 is pulse driven, the last 0.25μ s of the top of the grid 1 pulse must overlap the corresponding first 0.25μ s of the top of the delayed grid 2 pulse.

6. When d.c. priming is used on grid 1, a negative bias of 100 to 200V must be applied to grid 2 to ensure anode voltage hold-off. D.C. priming is recommended for pulse modulator and crowbar service.
7. D.C. negative bias voltages must not be applied to grid 1. When grid 1 is pulse driven, the potential of grid 1 may vary between -10 and $+5V$ with respect to cathode potential during the period between the completion of recovery and the commencement of the succeeding grid pulse.
8. All tubes are subjected to an acceleration of $10g$ at $50Hz$ before testing. In addition, samples are tested under the following conditions:
 - (a) **Linear Acceleration** $12g$ (min) is applied and maintained for 1 minute at right angles to and in each direction along the major axis of the tube. A heater voltage of $6.3V$ is applied during the test.
 - (b) **Resonance Search** Vibration is applied in two mutually perpendicular directions, one of which is parallel to the longitudinal axis of the tube. The frequency is swept at a rate not exceeding one octave per minute between 10 and $150Hz$, with accelerations of $2g$ (min). All resonances detectable visually or electrically are noted for information and also for use in test (c). Normal operating voltages are applied during the test.
 - (c) **Vibration Fatigue** Each tube is subjected to vibration for two periods of ten hours. In one period the direction of vibration is parallel to the longitudinal axis of the tube, and in the other the direction is perpendicular to the longitudinal axis of the tube. An acceleration of $2g$ is used and the frequency is that of the strongest resonance detected during the resonance search. If no resonances were detected in the search, then a frequency of $150Hz$ is used. A heater voltage of $6.3V$ is applied during the test.

Tubes must pass operational tests after the above procedure has been completed.

9. Typical figures are obtained on test using conditions of minimum grid drive. Improved performance can be expected by increasing the grid drive.

10. The time interval between the instant when the open circuit grid 2 voltage passes cathode potential and the instant when anode conduction takes place.
11. The drift in delay time over a period from 10 seconds to 10 minutes after reaching full voltage.
12. For equipment where jitter and anode delay time drift are not important, the tube may be triggered by applying a single pulse to grid 2 and connecting grid 1 to grid 2 via a 100pF capacitor shunted by a 10M Ω resistor.
13. For screened grid operation, grid 2 may be connected to cathode provided that a low impedance grid drive pulse (say 50 Ω) is used. Under these conditions the critical d.c. anode voltage for conduction may be higher than normal.

X-RAY WARNING

X-rays are emitted by the CX1191A from the region of the anode, but the radiation is usually reduced to a safe level by the metal panels of the equipment in which the tube operates.

OUTLINE (All dimensions without limits are nominal)

2953

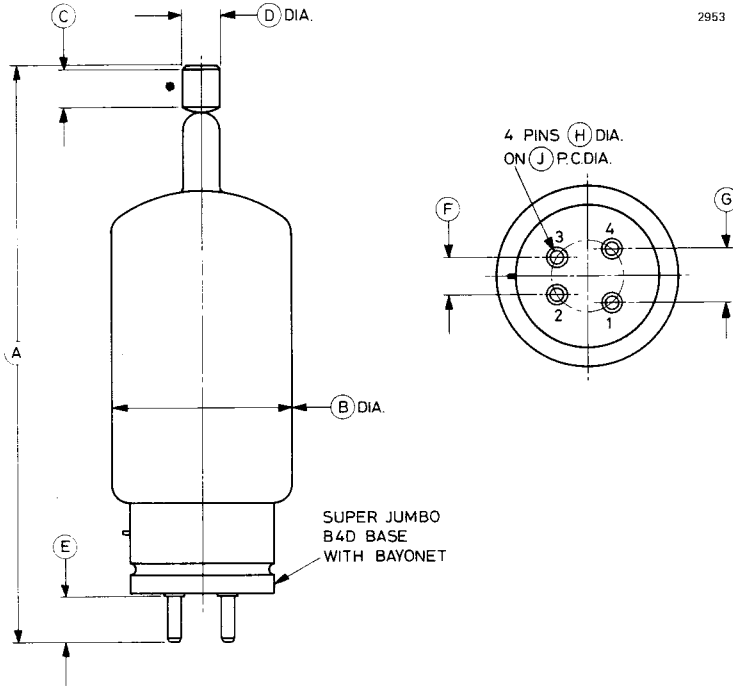

Ref	Inches	Millimetres	Pin	Element
A	8.000 ± 0.250	203.2 ± 6.4	1	Grid 1
B	2.562 max	65.08 max	2	Heater, cathode
C	0.500 min	12.70 min	3	Heater
D	0.566 ± 0.007	14.38 ± 0.18	4	Grid 2
E	0.625	15.88	Top cap	Anode
F	0.562	14.28		
G	0.750	19.05		
H	0.187 ± 0.003	4.750 ± 0.076		
J	1.000	25.40		

Millimetre dimensions have been derived from inches.



CX1191D

DEUTERIUM THYRATRON

The data to be read in conjunction with the Hydrogen Thyatron Preamble.

ABRIDGED DATA

Deuterium-filled tetrode thyatron of ruggedized construction, suitable for use in airborne or mobile military radar systems. It is used for switching peak powers up to 8.0MW at high repetition rates under a wide range of operating conditions. It has a rugged, internally connected reservoir. Samples are subjected to extensive environmental test procedures including vibration at 2g from 50 to 200Hz.

Peak forward anode voltage	35	kV max
Peak anode current	500	A max
Average anode current	0.5	A max
Anode heating factor	8.0×10^9	V.A.p.p.s. max
Peak output power	8.0	MW max

GENERAL

Electrical

Cathode (connected internally to one end of heater)	oxide coated
Heater voltage	$6.3 \pm 7\%$ V
Heater current	12.5 A
Tube heating time (minimum) (see note 1)	5.0 min
Inter-electrode capacitances (approximate):	
anode to grid 2 (grid 1 and cathode not connected)	9.0 pF
anode to grid 1 (grid 2 and cathode not connected)	4.5 pF
anode to cathode (grid 1 and grid 2 not connected)	18 pF

Mechanical

Overall length	8.250 inches (209.6mm) max
Overall diameter	2.562 inches (65.1mm) max
Net weight	12 ounces (340g) approx
Mounting position (see note 2)	any
Base	B4D, bayonet
Top cap	B.S.448-CT3

Cooling	natural
--------------------------	---------

PULSE MODULATOR SERVICE

MAXIMUM AND MINIMUM RATINGS (Absolute values)

	Min	Max	
Anode			
Peak forward anode voltage (see note 1)	—	35	kV
Peak inverse anode voltage (see note 3)	—	10	kV
Peak anode current	—	500	A
Average anode current	—	0.5	A
Rate of rise of anode current (see note 4)	—	2500	A/ μ s
Anode heating factor	—	8.0×10^9	V.A.p.p.s.

Grid 2

Unloaded grid 2 drive pulse voltage (see note 5)	200	750	V
Grid 2 pulse duration	1.0	—	μ s
Rate of rise of grid 2 pulse (see note 4)	1.0	—	kV/ μ s
Grid 2 pulse delay	0.5	3.0	μ s
Peak inverse grid 2 voltage	—	200	V
Loaded grid 2 bias voltage	-50	-120	V
Forward impedance of grid 2 drive circuit	100	1000	Ω

Grid 1 — D.C. Primed (See note 6)

D.C. grid 1 unloaded priming voltage	75	150	V
D.C. grid 1 priming current	50	100	mA

Grid 1 — Pulsed

Unloaded grid 1 drive pulse voltage (see note 5)	300	750	V
Grid 1 pulse duration	2.0	—	μ s
Rate of rise of grid 1 pulse (see note 4)	1.0	—	kV/ μ s
Peak inverse grid 1 voltage	—	200	V
Loaded grid 1 bias voltage	—	—	see note 7
Peak grid 1 drive current	0.3	1.0	A

Cathode

Heater voltage	$6.3 \pm 7\frac{1}{2}\%$	—	V
Tube heating time (see note 1)	5.0	—	min

Environmental

Environmental performance	—	—	see note 8
Ambient temperature	-55	+90	$^{\circ}$ C
Altitude	—	10 000	ft
	—	3	km

CHARACTERISTICS

	Min	Typical	Max	
Critical d.c. anode voltage for conduction (see note 9)	—	0.3	1.0	kV
Anode delay time (see notes 9 and 10)	—	0.15	0.25	μ s
Anode delay time drift (see notes 9, 11 and 12)	—	20	50	ns
Time jitter (see notes 9 and 12)	—	1.0	5.0	ns
Heater current (at 6.3V)	11	12.5	13	A

RATINGS FOR SINGLE SHOT OR CROWBAR SERVICE (See note 6)

D.C. forward anode voltage (see note 1)	35	kV max
Peak anode current	5000	A max
Product of peak current and pulse length	0.2	A.s max
Repetition frequency	1 pulse per 10s	max

NOTES

1. The maximum permissible peak forward voltage for instantaneous starting is 20kV, and there must be no overshoot.
For single shot and crowbar applications, each tube is tested to withstand 35kV d.c. at 6.3V heater voltage for 10 minutes, with 100mA grid 1 drive current and $-100V$ grid 2 bias.
2. Clamping is only permissible by the base.
3. The peak inverse voltage exclusive of a spike of 1 microsecond maximum duration and 20kV maximum amplitude must not exceed 12kV for the first 5 microseconds after the anode pulse and must not exceed 5.0kV thereafter.
4. The rate of rise refers to that part of the leading edge of the pulse between 25% and 75% of the pulse amplitude.
5. Measured with respect to cathode. In certain cases the maximum drive pulse voltage may be exceeded without damage to the tube; a maximum value of 2.5kV is then recommended. When grid 1 is pulse driven, the last 0.25 μ s of the top of the grid 1 pulse must overlap the corresponding first 0.25 μ s of the top of the delayed grid 2 pulse.

6. When d.c. priming is used on grid 1, a negative bias of 100 to 200V must be applied to grid 2 to ensure anode voltage hold-off. D.C. priming is recommended for pulse modulator and crowbar service.
7. D.C. negative bias voltages must not be applied to grid 1. When grid 1 is pulse driven, the potential of grid 1 may vary between -10 and $+5V$ with respect to cathode potential during the period between the completion of recovery and the commencement of the succeeding grid pulse.
8. All tubes are subjected to an acceleration of $10g$ at $50Hz$ before testing. In addition, samples are tested under the following conditions:
 - (a) **Linear Acceleration** $12g$ (min) is applied and maintained for 1 minute at right angles to and in each direction along the major axis of the tube. A heater voltage of $6.3V$ is applied during the test.
 - (b) **Resonance Search** Vibration is applied in two mutually perpendicular directions, one of which is parallel to the longitudinal axis of the tube. The frequency is swept at a rate not exceeding one octave per minute between 10 and $200Hz$, with accelerations of $2g$ (min). All resonances detectable visually or electrically are noted for information and also for use in test (c). Normal operating voltages are applied during the test.
 - (c) **Vibration Fatigue** Each tube is subjected to vibration for two periods of ten hours. In one period the direction of vibration is parallel to the longitudinal axis of the tube, and in the other the direction is perpendicular to the longitudinal axis of the tube. An acceleration of $2g$ is used and the frequency is that of the strongest resonance detected during the resonance search. If no resonances were detected in the search, then a frequency of $150Hz$ is used. A heater voltage of $6.3V$ is applied during the test.

Tubes must pass operational tests after the above procedure has been completed.

9. Typical figures are obtained on test using conditions of minimum grid drive. Improved performance can be expected by increasing the grid drive.
10. The time interval between the instant when the open circuit grid 2 voltage passes cathode potential and the instant when anode conduction takes place.
11. The drift in delay time over a period from 10 seconds to 10 minutes after reaching full voltage.
12. For equipment where jitter and anode delay time drift are not important, the tube may be triggered by applying a single pulse to grid 2 and connecting grid 1 to grid 2 via a 100pF capacitor shunted by a 10M Ω resistor.

For screened grid operation, grid 2 may be connected to cathode provided that a low impedance grid drive pulse (say 50 ohms) is used. Under these conditions, the critical d.c. anode voltage for conduction may be higher than normal.

X-RAY WARNING

X-rays are emitted by the CX1191D from the region of the anode, but the radiation is usually reduced to a safe level by the metal panels of the equipment in which the tube operates.

OUTLINE (All dimensions without limits are nominal)

2953

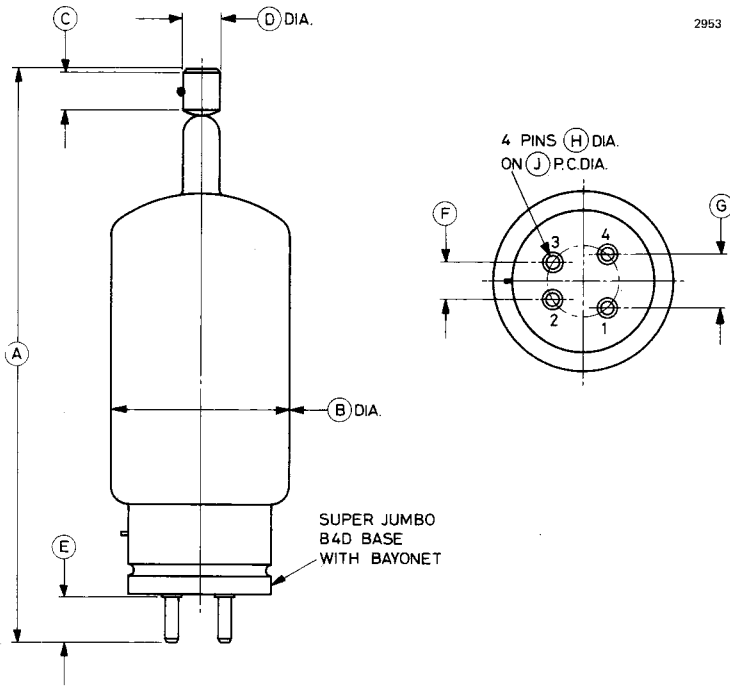

Ref	Inches	Millimetres	Pin	Element
A	8.000 ± 0.250	203.2 ± 6.4	1	Grid 1
B	2.562 max	65.08 max	2	Heater, cathode
C	0.500 min	12.70 min	3	Heater
D	0.566 ± 0.007	14.38 ± 0.18	4	Grid 2
E	0.625	15.88	Top cap	Anode
F	0.562	14.28		
G	0.750	19.05		
H	0.187 ± 0.003	4.750 ± 0.076		
J	1.000	25.40		

Millimetre dimensions have been derived from inches.



THREE-GAP CERAMIC THYRATRON

The data to be read in conjunction with the Hydrogen Thyatron Preamble.

ABRIDGED DATA

Deuterium-filled, three-gap, high voltage thyatron with ceramic/metal envelope, featuring low jitter, firing time and drift. Suitable for switching high power at high pulse repetition rates or for switching long pulses. A reservoir operating from a separate heater supply is incorporated.

Peak forward anode voltage	120	kV max
Peak anode current (see page 2)	6000	A max
Average anode current	6.0	A max
Anode heating factor	140×10^9	V.A.p.p.s. max
Peak output power	360	MW max

GENERAL

Electrical

Cathode (connected internally to one end of heater)	oxide coated
Cathode heater voltage	$6.3 \pm 5\%$ V
Cathode heater current	40 A
Reservoir heater voltage (see note 1)	5.0 V
Reservoir heater current	10 A
Tube heating time (minimum)	15 min
Inter-electrode capacitances (approximate):	
anode to gradient grid 2	40 pF
gradient grid 2 to gradient grid 1	40 pF
gradient grid 1 to grid 2	40 pF

Mechanical

Seated height	15.312 inches (388.9 mm) max	☆
Clearance required below mounting flange	2.500 inches (63.5mm) min	
Overall diameter (mounting flange)	6.000 inches (152.4mm) nom	
Net weight	18½ pounds (8.4kg) approx	
Mounting position (see note 2)	any	
Tube connections	see outline	

☆ Indicates a change

Cooling	forced-air or liquid
Forced-air	see note 3
Liquid	oil or coolant immersion
Maximum temperature of envelope	200 °C

Natural ambient cooling is usually insufficient to maintain the ceramic/metal envelope temperature below the maximum value specified above. Cooling by oil or coolant immersion is advised in view of the high voltages present. Further information is contained in the relevant section of the Preamble.

PULSE MODULATOR SERVICE

MAXIMUM AND MINIMUM RATINGS (Absolute values)

	Min	Max	
Anode			
Peak forward anode voltage (see note 4)	—	120	kV
Peak inverse anode voltage (see note 5)	—	120	kV
Peak anode current	—	6000	A
Peak anode current (pulse repetition rate limited to 60p.p.s. max)	—	8000	A
Average anode current	—	6.0	A
Rate of rise of anode current (see notes 6 and 7)	—	10 000	A/μs
Anode heating factor	—	140 x 10 ⁹	V.A.p.p.s.

Grid 2

Unloaded grid 2 drive pulse voltage (see note 8)	400	2000	V
Grid 2 pulse duration	1.0	—	μs
Rate of rise of grid 2 pulse (see note 7)	1.0	—	kV/μs
Grid 2 pulse delay	0.5	3.0	μs
Peak inverse grid 2 voltage	—	450	V
Loaded grid 2 bias voltage (see note 9)	-50	-200	V
Forward impedance of grid 2 drive circuit	50	500	Ω

Grid 1 — D.C. Primed (See note 10)

D.C. grid 1 unloaded priming voltage	75	150	V
D.C. grid 1 priming current	75	150	mA

MAXIMUM AND MINIMUM RATINGS — continued

Grid 1 — Pulsed

	Min	Max	
Unloaded grid 1 drive pulse voltage (see note 8)	400	1000	V
Grid 1 pulse duration	2.0	—	μ s
Rate of rise of grid 1 pulse (see note 7)	1.0	—	kV/ μ s
Peak inverse grid 1 voltage	—	450	V
Loaded grid 1 bias voltage			see note 11
Peak grid 1 drive current	0.5	1.5	A

Cathode

Heater voltage	$6.3 \pm 5\%$		V
Heating time	15	—	min

Reservoir

Heater voltage (see note 1)	4.5	6.5	V
Heating time	15	—	min

Environmental

Ambient temperature	−50	+90	$^{\circ}$ C
Altitude	—	10 000	ft
	—	3	km

CHARACTERISTICS

	Min	Typical	Max	
Critical d.c. anode voltage for conduction (see note 12)	—	5.0	7.0	kV
Anode delay time (see notes 12 and 13)	—	0.1	0.25	μ s
Anode delay time drift (see notes 12 and 14)	—	15	50	ns
Time jitter (see note 12)	—	1.0	5.0	ns
Cathode heater current (at 6.3V)	35	40	45	A
Reservoir heater current (at 5.0V)	8.0	10	12	A

RATINGS FOR SINGLE SHOT OR CROWBAR SERVICE (See note 10)

D.C. forward anode voltage	105	kV max
Peak anode current	60 000	A max
Product of peak current and pulse length	0.2	A.s max
Repetition frequency	1 pulse per 10s	max

NOTES

1. The reservoir heater must be decoupled with a suitable capacitor to avoid damage by spike voltages. The recommended reservoir heater voltage is stamped on individual tube envelopes.
2. The tube must be mounted by means of its mounting flange.
3. An adequate flow of air must be supplied to maintain the ceramic/metal envelope temperature below the maximum rated value.
4. The maximum permissible peak forward voltage for instantaneous starting is 85kV and there must be no overshoot.
5. The peak inverse voltage including spike must not exceed 20kV for the first 250 microseconds after the anode pulse.
6. For single shot or burst mode applications this parameter can exceed 100kA/ μ s. The ultimate value which can be attained depends to a large extent upon the external circuit.
7. This rate of rise refers to that part of the leading edge of the pulse between 25% and 75% of the pulse amplitude.
8. Measured with respect to cathode. When grid 1 is pulse driven, the last 0.25 μ s of the top of the grid 1 pulse must overlap the corresponding first 0.25 μ s of the top of the delayed grid 2 pulse.
9. The tube may be operated with a loaded grid 2 bias voltage of 0 to -50V provided that care is taken to ensure that the peak grid 1 drive current is sufficiently low to prevent triode firing (tube control by the grid 1 pulse).
10. When d.c. priming is used on grid 1, a negative bias of 100 to 200V must be applied to grid 2 to ensure anode voltage hold-off. D.C. priming is recommended for pulse modulator and crowbar service.
11. D.C. negative bias voltages must not be applied to grid 1. When grid 1 is pulse driven, the potential of grid 1 may vary between -10 and +5V with respect to cathode potential during the period between the completion of recovery and the commencement of the succeeding grid pulse.
12. Typical figures are obtained on test using conditions of minimum grid drive. Improved performance can be expected by increasing grid drive.

13. The time interval between the instant at which the rising unloaded grid 2 pulse reaches 25% of its pulse amplitude and the instant when anode conduction takes place.
14. The drift in delay time over a period from 10 seconds to 10 minutes after reaching full voltage.

☆ **HEALTH AND SAFETY HAZARDS**

EEV hydrogen thyratrons are safe to handle and operate, provided that the relevant precautions stated herein are observed. English Electric Valve Company does not accept responsibility for damage or injury resulting from the use of electronic devices it produces. Equipment manufacturers and users must ensure that adequate precautions are taken. Appropriate warning labels and notices must be provided on equipments incorporating EEV devices and in operating manuals.

High Voltage

Equipment must be designed so that personnel cannot come into contact with high voltage circuits. All high voltage circuits and terminals must be enclosed and fail-safe interlock switches must be fitted to disconnect the primary power supply and discharge all high voltage capacitors and stored charges in the electronic devices before allowing access. Interlock switches must not be bypassed to allow operation with access doors open.

X-Ray Radiation

All high voltage devices produce X-rays during operation and may require shielding. The X-ray radiation from hydrogen thyratrons is usually reduced to a safe level by enclosing the equipment with metal panels.

☆ Indicates a change

OUTLINE

3572C

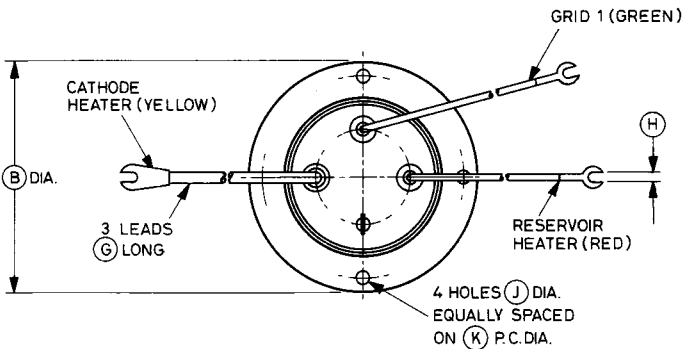
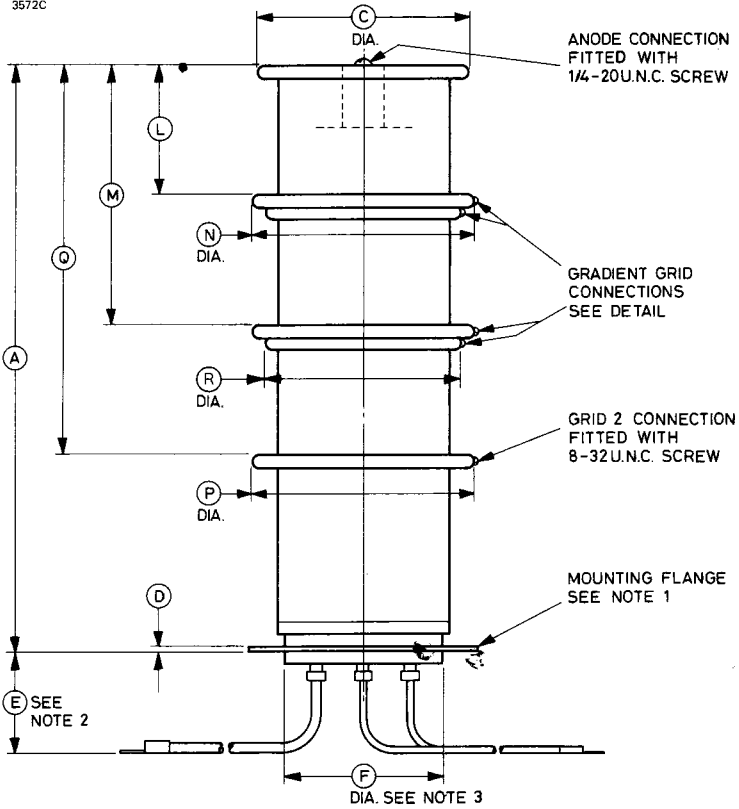

Detail of Gradient Grid Connections

3573A

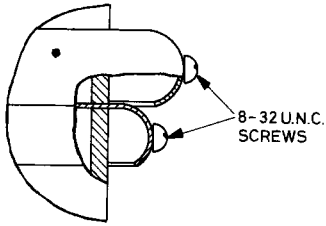

Outline Dimensions (All dimensions without limits are nominal)

Ref	Inches	Millimetres	Ref	Inches	Millimetres
☆ A	15.312 max	388.9 max	J	0.315	8.0
B	6.000	152.4	K	5.344	135.7
C	5.500	139.7	L	3.375	85.73
D	0.125	3.18	M	6.750	171.5
☆ E	2.250 min	57.15 min	N	5.875	149.2
F	4.187 max	106.3 max	P	5.875	149.2
G	7.000	177.8	Q	10.125	257.2
H	0.250	6.35	R	5.125	130.2

Millimetre dimensions have been derived from inches except dimension J.

Outline Notes

1. The mounting flange is the connection for the cathode, cathode heater return and reservoir heater return.
- ☆ 2. A minimum clearance of 2.250 inches (57.15 mm) must be allowed below the mounting flange.
3. The recommended mounting hole is 4.250 inches (108mm) diameter.

☆ Indicates a change

SCHEMATIC DIAGRAM

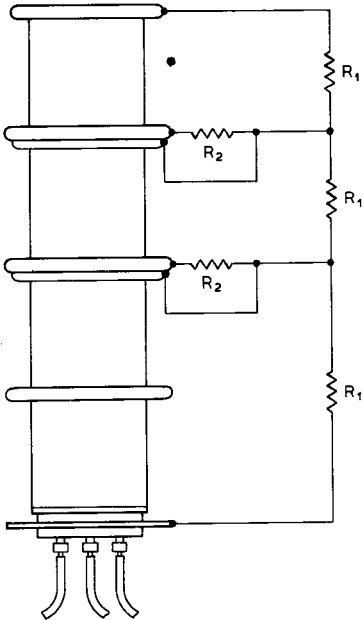

2184C

Recommended Values

$$R_1 = 10 \text{ to } 20\text{M}\Omega$$

$$R_2 = 470 \text{ to } 1000\Omega$$

Please consult EEV for alternative methods of connection.

Whilst EEV has taken care to ensure the accuracy of the information contained herein it accepts no responsibility for the consequences of any use thereof and also reserves the right to change the specification of goods without notice. EEV accepts no liability beyond that set out in its standard conditions of sale in respect of infringement of third party patents arising from the use of tubes or other devices in accordance with information contained herein.



THREE-GAP DOUBLE ENDED CERAMIC THYRATRON

The data to be read in conjunction with the Hydrogen Thyatron Preamble.

ABRIDGED DATA

Deuterium-filled, three-gap, double ended high voltage thyatron with ceramic/metal envelope, featuring low jitter, firing time and drift. Suitable for switching high power and for switching long pulses.

Reservoirs are incorporated, operating from separate heater supplies. The tube is electrically symmetrical, with identical cathode and grid assemblies at both ends; the flange electrode which is positive when the tube is triggered is referred to as the anode.

Peak forward anode voltage	105	kV max
Peak anode current (see page 2)	6000	A max
Average anode current	6.0	A max
Anode heating factor	120×10^9 V.A.p.p.s.	max
Peak output power	260	MW max

GENERAL

Electrical

Cathodes (connected internally to one end of associated heater)		oxide coated
Cathode heater voltage (each end)	$6.3 \pm 5\%$	V
Cathode heater current (each end)	40	A
Reservoir heater voltage (each end) (see note 1)	5.0	V
Reservoir heater current (each end)	10	A
Tube heating time (minimum)	15	min
Inter-electrode capacitances (each gap)	40	pF approx

Mechanical

Seated height (flange to flange)	19.680 inches (499.9mm)	nom
Clearance required below flanges	2.500 inches (63.5mm)	min
Overall diameter	6.000 inches (152.4mm)	nom
Net weight	21 pounds (9.5kg)	approx
Mounting position (see note 2)		any
Tube connections		see outline

Cooling	forced-air or liquid
Forced-air	see note 3
Liquid	oil or coolant immersion
Maximum temperature of envelope	200 °C

Natural ambient cooling is usually insufficient to maintain the ceramic/metal envelope temperature below the maximum value specified above. Cooling by oil or coolant immersion is advised in view of the high voltages present. Further information is contained in the relevant section of the Preamble.

PULSE MODULATOR SERVICE (See note 4)

MAXIMUM AND MINIMUM RATINGS (Absolute values)

	Min	Max	
Anode			
Peak forward or inverse anode voltage (see note 5)	—	105	kV
Peak anode current	—	6000	A
Peak anode current (pulse repetition rate limited to 60p.p.s. max)	—	8000	A
Average anode current	—	6.0	A
Rate of rise of anode current (see notes 6 and 7)	—	10 000	A/ μ s
Anode heating factor	—	120 x 10 ⁹	V.A.p.p.s.

Grid 2

Unloaded grid 2 drive pulse voltage (see note 8)	400	2000	V
Grid 2 pulse duration	1.0	—	μ s
Rate of rise of grid 2 pulse (see note 6)	1.0	—	kV/ μ s
Grid 2 pulse delay	0.5	3.0	μ s
Peak inverse grid 2 voltage	—	450	V
Loaded grid 2 bias voltage	-50	-200	V
Forward impedance of grid 2 drive circuit	50	500	Ω

Grid 1 — D.C. Primed (see note 9)

D.C. grid 1 unloaded priming voltage	75	150	V
D.C. grid 1 priming current	25	50	mA

MAXIMUM AND MINIMUM RATINGS — continued

	Min	Max	
Grid 1 — Pulsed (see note 10)			
Unloaded grid 1 drive pulse voltage (see note 8)	400	1000	V
Grid 1 pulse duration	2.0	—	μ s
Rate of rise of grid 1 pulse (see note 6)	1.0	—	kV/ μ s
Peak inverse grid 1 voltage	—	450	V
Loaded grid 1 bias voltage			see note 11
Peak grid 1 drive current	0.5	1.5	A

Cathodes

Heater voltage		6.3 ± 5%	V
Heating time	15	—	min

Reservoirs

Heater voltage (see note 1)	3.5	6.5	V
Heating time	15	—	min

Environmental

Ambient temperature	−50	+90	°C
Altitude	—	10 000	ft
	—	3	km

CHARACTERISTICS

	Min	Typical	Max	
Critical d.c. anode voltage for conduction (see note 12)	—	5.0	7.0	kV
Anode delay time (see notes 12 and 13)	—	0.1	0.25	μ s
Anode delay time drift (see notes 12 and 14)	—	15	50	ns
Time jitter (see note 12)	—	1.0	5.0	ns
Cathode heater current (at 6.3V)	35	40	45	A
Reservoir heater current (at 5.0V)	8.0	10	12	A

RATINGS FOR SINGLE SHOT OR CROWBAR SERVICE (see note 9)

D.C. forward anode voltage	90	kV max
Peak anode current	60 000	A max
Product of peak current and pulse duration	2.0	A.s max
Repetition frequency	1 pulse per 10s	max

NOTES

1. The reservoir heaters must be decoupled with suitable capacitors to avoid damage by spike voltages. The recommended voltage for each tube is marked on the tube, and both reservoirs must be operated at the same heater voltage.
2. The tube must be mounted by one of the cathode flanges, with flexible connections to all other electrodes.
3. An adequate flow of air must be supplied to maintain the ceramic/metal envelope temperature below the maximum rated value.
4. Triggered charging techniques are recommended because the tube has a relatively long recovery time (100–200 μ s).
5. This is the maximum hold off voltage in either direction before the tube is triggered. The maximum permissible peak forward voltage for instantaneous starting is 90kV and there must be no overshoot.
6. This rate of rise refers to that part of the leading edge of the pulse between 25% and 75% of the pulse amplitude.
7. For single shot or burst mode applications this parameter can exceed 100kA/ μ s; the ultimate value which can be attained depends upon the external circuit, but the heating factor must be reduced.
8. Measured with respect to the associated cathode. The tube is triggered by pulsing the grid 2 at the negative end, while the grid 2 at the anode (positive) end is connected to its associated cathode and carries most of the forward anode current. When grid 1 is pulse driven, the last 0.25 μ s of the top of the grid 1 pulse must overlap the corresponding first 0.25 μ s of the top of the delayed grid 2 pulse.
9. When d.c. priming is used on grid 1, a negative bias of 100 to 200V must be applied to grid 2 to ensure anode voltage hold-off. D.C. priming of grid 1 at both ends is recommended for crowbar service.
10. When pulse drive is applied to the triggered end of the tube, the grid 1 at the anode (positive) end will normally be d.c. primed.
11. D.C. negative bias voltages must not be applied to grid 1. When grid 1 is pulse driven, the potential of grid 1 may vary between –10 and +5V with respect to cathode during the period between the completion of recovery and the start of the next grid pulse.

12. Typical figures are obtained on test using conditions of minimum grid drive. Improved performance can be expected with increased grid drive.
13. The time interval between the instant at which the rising unloaded grid 2 pulse reaches 25% of its pulse amplitude and the instant when anode conduction takes place.
14. The drift in delay time over a period from 10 seconds to 10 minutes after reaching full voltage.

X-RAY WARNING

X-rays may be emitted by the CX1192B but the radiation is usually reduced to a safe level by the metal surrounds and panels of the equipment in which the tube operates.

SCHEMATIC DIAGRAM

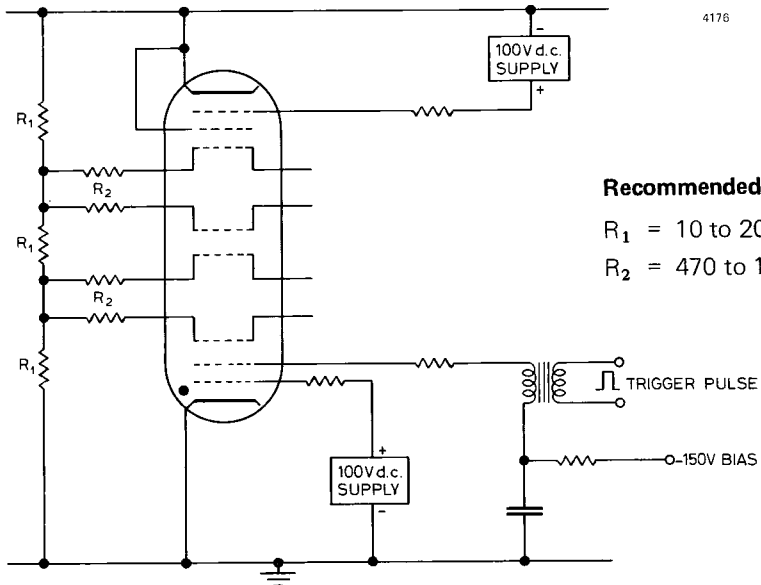

Recommended Values

$R_1 = 10 \text{ to } 20M\Omega$

$R_2 = 470 \text{ to } 1000\Omega$

OUTLINE

4184

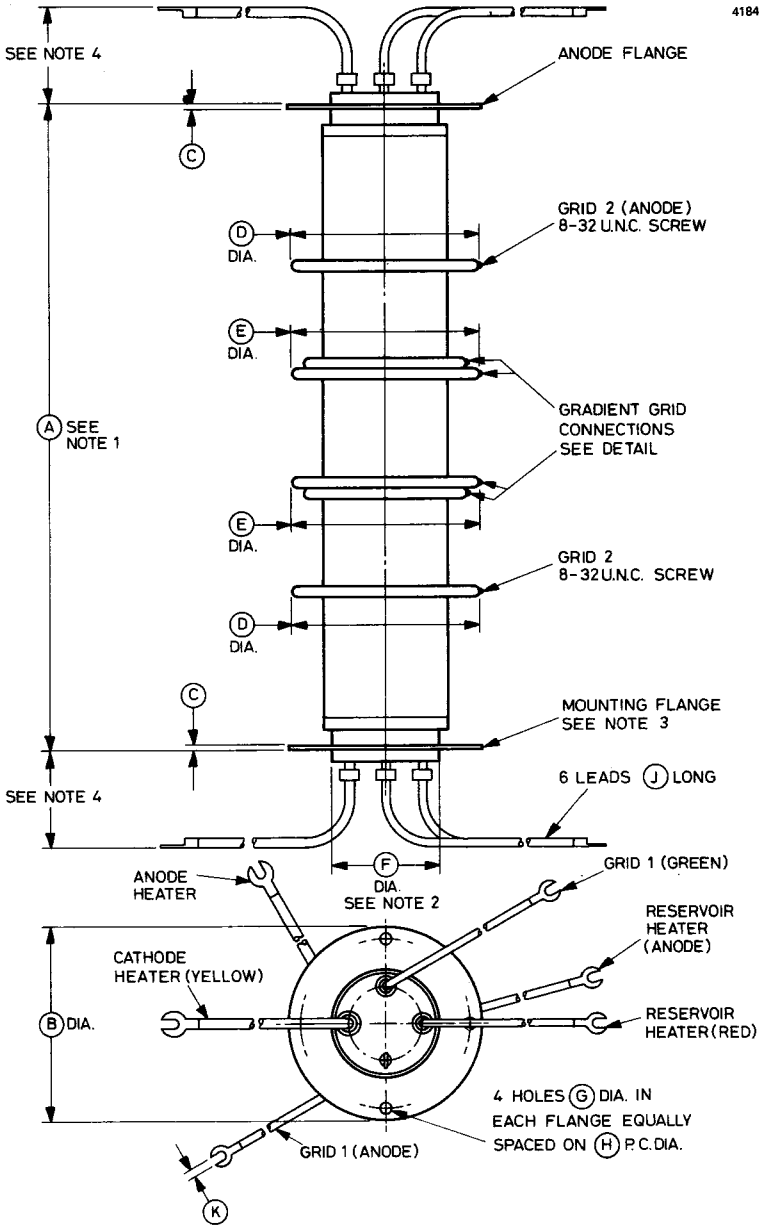

Detail of Gradient Grid Connections

3573A

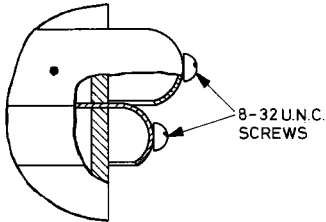

Outline Dimensions (All dimensions without limits are nominal)

Ref	Inches	Millimetres
A	19.680 ± 0.100	499.87 ± 2.54
B	6.000	152.4
C	0.125	3.18
D	5.875	149.2
E	5.875	149.2
F	4.187 max	106.3 max
G	0.315	8.0
H	5.344	135.7
J	7.000	177.8
K	0.250	6.35

Millimetre dimensions have been derived from inches.

Outline Notes

1. The two flanges will be parallel within 0.059 inch (1.5mm).
2. The recommended mounting hole is 4.250 inches (108.0mm) diameter.
3. The tube must be mounted by one flange only. The flange is the connection for the cathode, cathode heater return and reservoir heater return.
4. A minimum clearance of 2.500 inches (63.50mm) must be allowed below the mounting flange.

Whilst EEV has taken care to ensure the accuracy of the information contained herein it accepts no responsibility for the consequences of any use thereof and also reserves the right to change the specification of goods without notice. EEV accepts no liability beyond that set out in its standard conditions of sale in respect of infringement of third party patents arising from the use of tubes or other devices in accordance with information contained herein.



FOUR GAP CERAMIC THYRATRON

The data to be read in conjunction with the Hydrogen Thyatron Preamble.

ABRIDGED DATA

Deuterium-filled, four-gap, high voltage thyatron with ceramic/metal envelope, featuring low jitter, firing time and drift. Suitable for switching high power at high pulse repetition rates or for switching long pulses. A reservoir operating from a separate heater supply is incorporated.

Peak forward anode voltage	160	kV max
Peak anode current (see page 2)	6000	A max
Average anode current	6.0	A max
Anode heating factor	140×10^9	V.A.p.p.s. max
Peak output power	400	MW max

GENERAL

Electrical

Cathode (connected internally to one end of heater)	oxide coated	
Cathode heater voltage	$6.3 \pm 5\%$	V
Cathode heater current	40	A
Reservoir heater voltage (see note 1)	5.0	V
Reservoir heater current	10	A
Tube heating time (minimum)	15	min
Inter-electrode capacitances (approximate):		
anode to gradient grid 3	40	pF
gradient grid 3 to gradient grid 2	40	pF
gradient grid 2 to gradient grid 1	40	pF
gradient grid 1 to grid 2	40	pF

Mechanical

Seated height	18.812 inches (477.8 mm) max	☆
Clearance required below mounting flange	2.500 inches (63.5mm) min	
Overall diameter (mounting flange)	6.000 inches (152.4mm) nom	
Net weight	23¾ pounds (10.8kg) approx	
Mounting position (see note 2)		any
Tube connections		see outline

☆ Indicates a change

Cooling	forced-air or liquid
Forced-air	see note 3
Liquid	oil or coolant immersion
Maximum temperature of envelope	200 °C

Natural ambient*cooling is usually insufficient to maintain the ceramic/metal envelope temperature below the maximum value specified above. Cooling by oil or coolant immersion is advised in view of the high voltages present. Further information is contained in the relevant section of the Preamble.

PULSE MODULATOR SERVICE

MAXIMUM AND MINIMUM RATINGS (Absolute values)

	Min	Max	
Anode			
Peak forward anode voltage (see note 4)	—	160	kV
Peak inverse anode voltage (see note 5)	—	160	kV
Peak anode current	—	6000	A
Peak anode current (pulse repetition rate limited to 60p.p.s. max)	—	8000	A
Average anode current	—	6.0	A
Rate of rise of anode current (see notes 6 and 7)	—	10 000	A/μs
Anode heating factor	—	140 x 10 ⁹	V.A.p.p.s.

Grid 2

Unloaded grid 2 drive pulse voltage (see note 8)	400	2000	V
Grid 2 pulse duration	1.0	—	μs
Rate of rise of grid 2 pulse (see note 7)	1.0	—	kV/μs
Grid 2 pulse delay	0.5	3.0	μs
Peak inverse grid 2 voltage	—	450	V
Loaded grid 2 bias voltage (see note 9)	-50	-200	V
Forward impedance of grid 2 drive circuit	50	500	Ω

Grid 1 – D.C. Primed (See note 10)

D.C. grid 1 unloaded priming voltage	75	150	V
D.C. grid 1 priming current	75	150	mA

MAXIMUM AND MINIMUM RATINGS — continued

Grid 1 — Pulsed	Min	Max	
Unloaded grid 1 drive pulse voltage (see note 8)	400	1000	V
Grid 1 pulse duration	2.0	—	μ s
Rate of rise of grid 1 pulse (see note 7)	1.0	—	kV/ μ s
Peak inverse grid 1 voltage	—	450	V
Loaded grid 1 bias voltage			see note 11
Peak grid 1 drive current	0.5	1.5	A

Cathode

Heater voltage	$6.3 \pm 5\%$		V
Heating time	15	—	min

Reservoir

Heater voltage (see note 1)	4.5	6.5	V
Heating time	15	—	min

Environmental

Ambient temperature	-50	+90	$^{\circ}$ C
Altitude	—	10 000	ft
	—	3	km

CHARACTERISTICS

	Min	Typical	Max	
Critical d.c. anode voltage for conduction (see note 12)	—	7.0	10	kV
Anode delay time (see notes 12 and 13)	—	0.1	0.25	μ s
Anode delay time drift (see notes 12 and 14)	—	15	50	ns
Time jitter (see note 12)	—	1.0	5.0	ns
Cathode heater current (at 6.3V)	35	40	45	A
Reservoir heater current (at 5.0V)	8.0	10	12	A

RATINGS FOR SINGLE SHOT OR CROWBAR SERVICE (See note 10)

D.C. forward anode voltage		140	kV max
Peak anode current		60 000	A max
Product of peak current and pulse length		2.0	A.s max
Repetition frequency		1 pulse per 10s	max

NOTES

1. The reservoir heater must be decoupled with a suitable capacitor to avoid damage by spike voltages. The recommended reservoir heater voltage is stamped on individual tube envelopes.
2. The tube must be mounted by means of its mounting flange.
3. An adequate flow of air must be supplied to maintain the ceramic/metal envelope temperature below the maximum rated value.
4. The maximum permissible peak forward voltage for instantaneous starting is 80kV and there must be no overshoot.
5. The peak inverse voltage including spike must not exceed 20kV for the first 250 microseconds after the anode pulse.
6. For single shot or burst mode applications this parameter can exceed 100kA/ μ s. The ultimate value which can be attained depends to a large extent upon the external circuit.
7. This rate of rise refers to that part of the leading edge of the pulse between 25% and 75% of the pulse amplitude.
8. Measured with respect to cathode. When grid 1 is pulse driven, the last 0.25 μ s of the top of the grid 1 pulse must overlap the corresponding first 0.25 μ s of the top of the delayed grid 2 pulse.
9. The tube may be operated with a loaded grid 2 bias voltage of 0 to -50V provided that care is taken to ensure that the peak grid 1 drive current is sufficiently low to prevent triode firing (tube control by the grid 1 pulse).
10. When d.c. priming is used on grid 1, a negative bias of 100 to 200V must be applied to grid 2 to ensure anode voltage hold-off. D.C. priming is recommended for pulse modulator and crowbar service.
11. D.C. negative bias voltages must not be applied to grid 1. When grid 1 is pulse driven, the potential of grid 1 may vary between -10 and +5V with respect to cathode potential during the period between the completion of recovery and the commencement of the succeeding grid pulse.
12. Typical figures are obtained on test using conditions of minimum grid drive. Improved performance can be expected by increasing grid drive.

13. The time interval between the instant at which the rising unloaded grid 2 pulse reaches 25% of its pulse amplitude and the instant when anode conduction takes place.
14. The drift in delay time over a period from 10 seconds to 10 minutes after reaching full voltage.

☆ HEALTH AND SAFETY HAZARDS

EEV hydrogen thyratrons are safe to handle and operate, provided that the relevant precautions stated herein are observed. English Electric Valve Company does not accept responsibility for damage or injury resulting from the use of electronic devices it produces. Equipment manufacturers and users must ensure that adequate precautions are taken. Appropriate warning labels and notices must be provided on equipments incorporating EEV devices and in operating manuals.

High Voltage

Equipment must be designed so that personnel cannot come into contact with high voltage circuits. All high voltage circuits and terminals must be enclosed and fail-safe interlock switches must be fitted to disconnect the primary power supply and discharge all high voltage capacitors and stored charges in the electronic devices before allowing access. Interlock switches must not be bypassed to allow operation with access doors open.

X-Ray Radiation

All high voltage devices produce X-rays during operation and may require shielding. The X-ray radiation from hydrogen thyratrons is usually reduced to a safe level by enclosing the equipment with metal panels.

☆ Indicates a change

OUTLINE

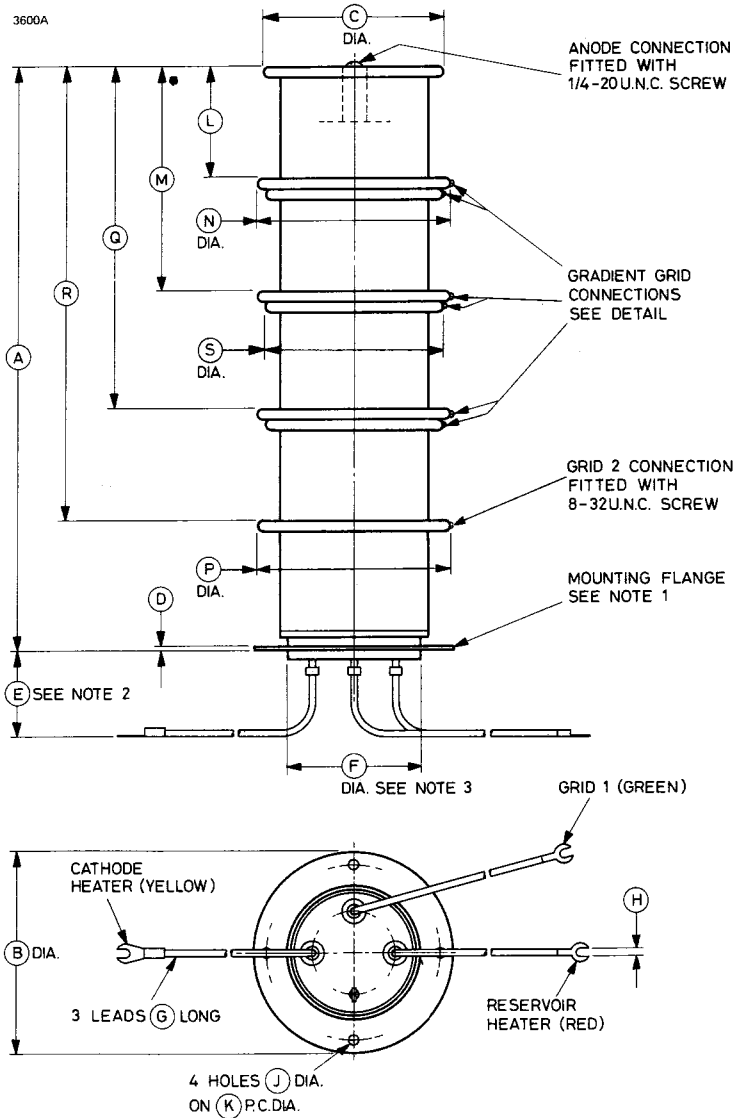

Detail of Gradient Grid Connections

3573A

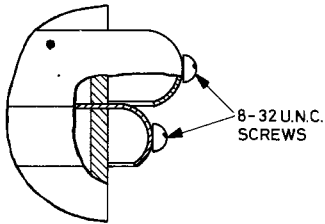

Outline Dimensions (All dimensions without limits are nominal)

Ref	Inches	Millimetres	Ref	Inches	Millimetres
☆ A	18.812 max	477.8 max	K	5.344	135.7
B	6.000	152.4	L	3.375	85.73
C	5.500	139.7	M	6.750	171.5
D	0.125	3.18	N	5.875	149.2
☆ E	2.250 min	57.15 min	P	5.875	149.2
F	4.187 max	106.3 max	Q	10.125	257.2
G	7.000	177.8	R	13.500	342.9
H	0.250	6.35	S	5.125	130.2
J	0.315	8.0			

Millimetre dimensions have been derived from inches except dimension J.

Outline Notes

1. The mounting flange is the connection for the cathode, cathode heater return and reservoir heater return.
- ☆ 2. A minimum clearance of 2.250 inches (57.15 mm) must be allowed below the mounting flange.
3. The recommended mounting hole is 4.250 inches (108mm) diameter.

☆ Indicates a change

SCHEMATIC DIAGRAM

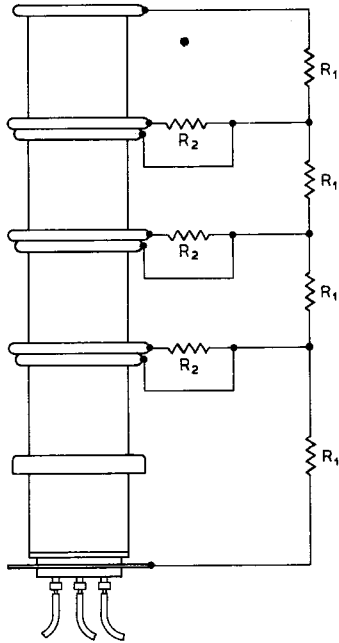

Recommended Values

$$R_1 = 10 \text{ to } 20\text{M}\Omega$$

$$R_2 = 470 \text{ to } 1000\Omega$$

Please consult EEV for alternative methods of connection.

Whilst EEV has taken care to ensure the accuracy of the information contained herein it accepts no responsibility for the consequences of any use thereof and also reserves the right to change the specification of goods without notice. EEV accepts no liability beyond that set out in its standard conditions of sale in respect of infringement of third party patents arising from the use of tubes or other devices in accordance with information contained herein.



FOUR-GAP DOUBLE ENDED CERAMIC THYRATRON

The data to be read in conjunction with the Hydrogen Thyatron Preamble.

ABRIDGED DATA

Deuterium-filled, four-gap, double ended high voltage thyatron with ceramic/metal envelope, featuring low jitter, firing time and drift. Suitable for switching high power and for switching long pulses.

Reservoirs are incorporated, operating from separate heater supplies. The tube is electrically symmetrical, with identical cathode and grid assemblies at both ends; the flange electrode which is positive when the tube is triggered is referred to as the anode.

Peak forward anode voltage	140	kV max
Peak anode current (see page 2)	6000	A max
Average anode current	6.0	A max
Anode heating factor	120 x 10 ⁹ V.A.p.p.s.	max
Peak output power	350	MW max

GENERAL

Electrical

Cathodes (connected internally to one end of associated heater)		oxide coated
Cathode heater voltage (each end)	6.3 ± 5%	V
Cathode heater current (each end)	40	A
Reservoir heater voltage (each end) (see note 1)	5.0	V
Reservoir heater current (each end)	10	A
Tube heating time (minimum)	15	min
Inter-electrode capacitances (each gap)	40	pF approx

Mechanical

Seated height (flange to flange)	23.130 inches (587.5mm) nom
Clearance required below flanges	2.500 inches (63.5mm) min
Overall diameter	6.000 inches (152.4mm) nom
Net weight	27.5 pounds (12.5kg) approx
Mounting position (see note 2)	any
Tube connections	see outline

Cooling	forced-air or liquid
Forced-air	see note 3
Liquid	oil or coolant immersion
Maximum temperature of envelope	200 °C

Natural ambient cooling is usually insufficient to maintain the ceramic/metal envelope temperature below the maximum value specified above. Cooling by oil or coolant immersion is advised in view of the high voltages present. Further information is contained in the relevant section of the Preamble.

PULSE MODULATOR SERVICE (See note 4)

MAXIMUM AND MINIMUM RATINGS (Absolute values)

	Min	Max	
Anode			
Peak forward or inverse anode voltage (see note 5)	—	140	kV
Peak anode current	—	6000	A
Peak anode current (pulse repetition rate limited to 60p.p.s. max)	—	8000	A
Average anode current	—	6.0	A
Rate of rise of anode current (see notes 6 and 7)	—	10 000	A/μs
Anode heating factor	—	120 x 10 ⁹	V.A.p.p.s.

Grid 2

Unloaded grid 2 drive pulse voltage (see note 8)	400	2000	V
Grid 2 pulse duration	1.0	—	μs
Rate of rise of grid 2 pulse (see note 6)	1.0	—	kV/μs
Grid 2 pulse delay	0.5	3.0	μs
Peak inverse grid 2 voltage	—	450	V
Loaded grid 2 bias voltage	−50	−200	V
Forward impedance of grid 2 drive circuit	50	500	Ω

Grid 1 – D.C. Primed (see note 9)

D.C. grid 1 unloaded priming voltage	75	150	V
D.C. grid 1 priming current	25	50	mA

MAXIMUM AND MINIMUM RATINGS – continued

	Min	Max	
Grid 1 – Pulsed (see note 10)			
Unloaded grid 1 drive pulse voltage (see note 8)	400	1000	V
Grid 1 pulse duration	2.0	—	μ s
Rate of rise of grid 1 pulse (see note 6)	1.0	—	kV/ μ s
Peak inverse grid 1 voltage	—	450	V
Loaded grid 1 bias voltage			see note 11
Peak grid 1 drive current	0.5	1.5	A

Cathodes

Heater voltage		$6.3 \pm 5\%$	V
Heating time	15	—	min

Reservoirs

Heater voltage (see note 1)	3.5	6.5	V
Heating time	15	—	min

Environmental

Ambient temperature	–50	+90	$^{\circ}$ C
Altitude	—	10 000	ft
	—	3	km

CHARACTERISTICS

	Min	Typical	Max	
Critical d.c. anode voltage for conduction (see note 12)	—	7.0	10	kV
Anode delay time (see notes 12 and 13)	—	0.1	0.25	μ s
Anode delay time drift (see notes 12 and 14)	—	15	50	ns
Time jitter (see note 12)	—	1.0	5.0	ns
Cathode heater current (at 6.3V)	35	40	45	A
Reservoir heater current (at 5.0V)	8.0	10	12	A

RATINGS FOR SINGLE SHOT OR CROWBAR SERVICE (see note 9)

D.C. forward anode voltage	120	kV max
Peak anode current	60 000	A max
Product of peak current and pulse duration	2.0	A.s max
Repetition frequency	1 pulse per 10s	max

NOTES

1. The reservoir heaters must be decoupled with suitable capacitors to avoid damage by spike voltages. The recommended voltage for each tube is marked on the tube, and both reservoirs must be operated at the same heater voltage.
2. The tube must be mounted by one of the cathode flanges, with flexible connections to all other electrodes.
3. An adequate flow of air must be supplied to maintain the ceramic/metal envelope temperature below the maximum rated value.
4. Triggered charging techniques are recommended because the tube has a relatively long recovery time (100–200 μ s).
5. This is the maximum hold off voltage in either direction before the tube is triggered. The maximum permissible peak forward voltage for instantaneous starting is 120kV and there must be no overshoot.
6. This rate of rise refers to that part of the leading edge of the pulse between 25% and 75% of the pulse amplitude.
7. For single shot or burst mode applications this parameter can exceed 100kA/ μ s; the ultimate value which can be attained depends upon the external circuit, but the heating factor must be reduced.
8. Measured with respect to the associated cathode. The tube is triggered by pulsing the grid 2 at the negative end, while the grid 2 at the anode (positive) end is connected to its associated cathode and carries most of the forward anode current. When grid 1 is pulse driven, the last 0.25 μ s of the top of the grid 1 pulse must overlap the corresponding first 0.25 μ s of the top of the delayed grid 2 pulse.
9. When d.c. priming is used on grid 1, a negative bias of 100 to 200V must be applied to grid 2 to ensure anode voltage hold-off. D.C. priming of grid 1 at both ends is recommended for crowbar service.
10. When pulse drive is applied to the triggered end of the tube, the grid 1 at the anode (positive) end will normally be d.c. primed.
11. D.C. negative bias voltages must not be applied to grid 1. When grid 1 is pulse driven, the potential of grid 1 may vary between –10 and +5V with respect to cathode during the period between the completion of recovery and the start of the next grid pulse.

12. Typical figures are obtained on test using conditions of minimum grid drive. Improved performance can be expected with increased grid drive.
13. The time interval between the instant at which the rising unloaded grid 2 pulse reaches 25% of its pulse amplitude and the instant when anode conduction takes place.
14. The drift in delay time over a period from 10 seconds to 10 minutes after reaching full voltage.

X-RAY WARNING

X-rays may be emitted by the CX1193B but the radiation is usually reduced to a safe level by the metal surrounds and panels of the equipment in which the tube operates.

SCHEMATIC DIAGRAM

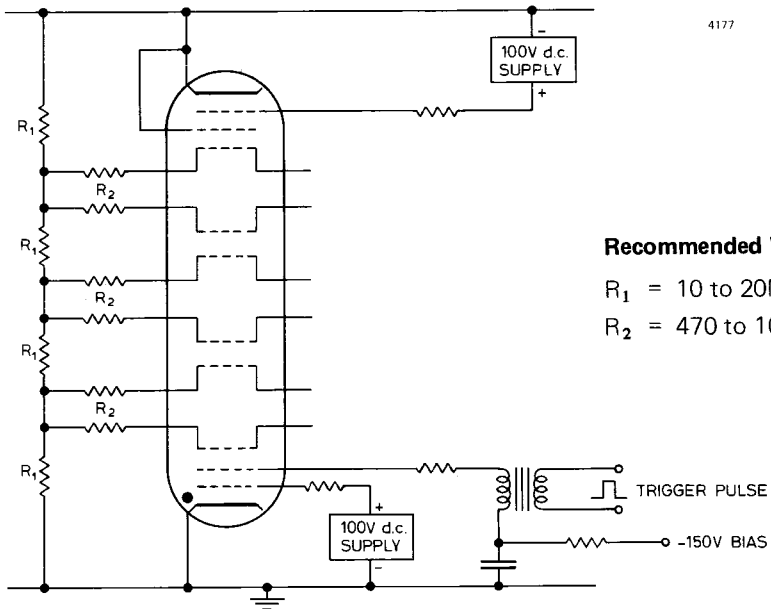

Recommended Values

$R_1 = 10 \text{ to } 20\text{M}\Omega$

$R_2 = 470 \text{ to } 1000\Omega$

OUTLINE

4185A

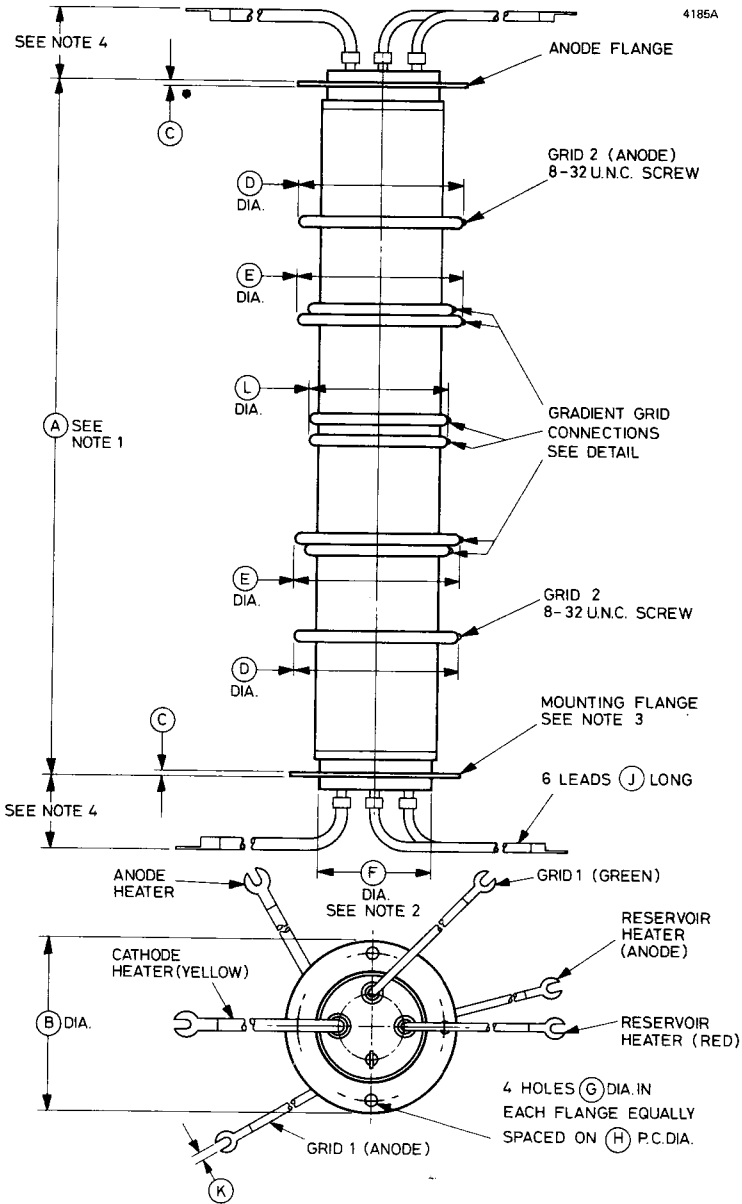

Whilst EEV has taken care to ensure the accuracy of the information contained herein it accepts no responsibility for the consequences of any use thereof and also reserves the right to change the specification of goods without notice. EEV accepts no liability beyond that set out in its standard conditions of sale in respect of infringement of third party patents arising from the use of tubes or other devices in accordance with information contained herein.

Detail of Gradient Grid Connections

3573A

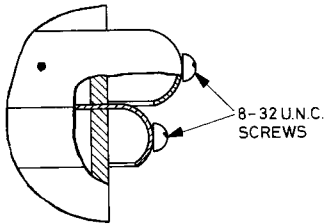

Outline Dimensions (All dimensions without limits are nominal)

Ref	Inches	Millimetres
A	23.130 \pm 0.200	587.50 \pm 5.08
B	6.000	152.4
C	0.125	3.18
D	5.875	149.2
E	5.875	149.2
F	4.187 max	106.3 max
G	0.315	8.0
H	5.344	135.7
J	7.000	177.8
K	0.250	6.35
L	5.125	130.2

Millimetre dimensions have been derived from inches.

Outline Notes

1. The two flanges will be parallel within 0.059 inch (1.5mm).
2. The recommended mounting hole is 4.250 inches (108.0mm) diameter.
3. The tube must be mounted by one flange only. The flange is the connection for the cathode, cathode heater return and reservoir heater return.
4. A minimum clearance of 2.500 inches (63.50mm) must be allowed below the mounting flange.



FOUR-GAP CERAMIC THYRATRON

The data to be read in conjunction with the Hydrogen Thyatron Preamble.

ABRIDGED DATA

Deuterium-filled, four-gap, high voltage thyatron with ceramic/metal envelope, featuring low jitter, firing time and drift. Suitable for switching high power at high pulse repetition rates or for switching long pulses. A reservoir operating from a separate heater supply is incorporated.

Peak forward anode voltage	160	kV max
Peak anode current (see page 2)	3000	A max
Average anode current	3.0	A max
Anode heating factor	70×10^9	V.A.p.p.s. max
Peak output power	200	MW max

GENERAL

Electrical

Cathode (connected internally to one end of heater)	oxide coated
Cathode heater voltage	$6.3 \pm 5\%$ V
Cathode heater current	21.5 A
Reservoir heater voltage (see note 1)	5.0 V
Reservoir heater current	7.0 A
Tube heating time (minimum)	15 min
Inter-electrode capacitances (approximate):	
anode to gradient grid 3	15 to 20 pF
gradient grid 3 to gradient grid 2	15 to 20 pF
gradient grid 2 to gradient grid 1	15 to 20 pF
gradient grid 1 to grid 2	15 to 20 pF

Mechanical

Seated height	16.875 inches (428.6mm) max
Clearance required below mounting flange	2.000 inches (50.8mm) min
Overall diameter (mounting flange)	4.375 inches (111.1mm) nom
Net weight	11 pounds (5kg) approx
Mounting position (see note 2)	any
Tube connections	see outline

Cooling	forced-air or liquid
Forced-air	see note 3
Liquid	oil or coolant immersion
Maximum temperature of envelope	200 °C

Natural ambient cooling is usually insufficient to maintain the ceramic/metal envelope temperature below the maximum value specified above. Cooling by oil or coolant immersion is advised in view of the high voltages present. Further information is contained in the relevant section of the Preamble.

PULSE MODULATOR SERVICE

MAXIMUM AND MINIMUM RATINGS (Absolute values)

	Min	Max	
Anode			
Peak forward anode voltage (see note 4)	—	160	kV
Peak inverse anode voltage (see note 5)	—	160	kV
Peak anode current	—	3000	A
Peak anode current (pulse repetition rate limited to 60p.p.s. max)	—	4000	A
Average anode current	—	3.0	A
Rate of rise of anode current (see notes 6 and 7)	—	5000	A/μs
Anode heating factor	—	70 x 10 ⁹	V.A.p.p.s.

Grid 2

Unloaded grid 2 drive pulse voltage (see note 8)	200	1000	V
Grid 2 pulse duration	1.0	—	μs
Rate of rise of grid 2 pulse (see note 7)	1.0	—	kV/μs
Grid 2 pulse delay	0.5	3.0	μs
Peak inverse grid 2 voltage	—	450	V
Loaded grid 2 bias voltage (see note 9)	-50	-200	V
Forward impedance of grid 2 drive circuit	50	1000	Ω

Grid 1 — D.C. Primed (See note 10)

D.C. grid 1 unloaded priming voltage	75	150	V
D.C. grid 1 priming current	75	150	mA

MAXIMUM AND MINIMUM RATINGS – continued

Grid 1 – Pulsed	Min	Max	
Unloaded grid 1 drive pulse voltage (see note 8)	300	1000	V
Grid 1 pulse duration	2.0	–	μ s
Rate of rise of grid 1 pulse (see note 7)	1.0	–	kV/ μ s
Peak inverse grid 1 voltage	–	450	V
Loaded grid 1 bias voltage			see note 11
Peak grid 1 drive current	0.3	1.0	A

Cathode

Heater voltage	$6.3 \pm 5\%$		V
Heating time	15	–	min

Reservoir

Heater voltage (see note 1)	4.5	6.5	V
Heating time	15	–	min

Environmental

Ambient temperature	–50	+90	$^{\circ}$ C
Altitude	–	10 000	ft
	–	3	km

CHARACTERISTICS

	Min	Typical	Max	
Critical d.c. anode voltage for conduction (see note 12)	–	7.0	10	kV
Anode delay time (see notes 12 and 13)	–	0.1	0.25	μ s
Anode delay time drift (see notes 12 and 14)	–	15	50	ns
Time jitter (see note 12)	–	1.0	5.0	ns
Cathode heater current (at 6.3V)	18	21.5	25	A
Reservoir heater current (at 5.0V)	6.0	7.0	8.0	A

RATINGS FOR SINGLE SHOT OR CROWBAR SERVICE (See note 10)

D.C. forward anode voltage	140	kV max
Peak anode current	30 000	A max
Product of peak current and pulse length	1.0	A.s max
Repetition frequency	1 pulse per 10s	max

NOTES

1. The reservoir heater must be decoupled with a suitable capacitor to avoid damage by spike voltages. The recommended reservoir heater voltage is stamped on individual tube envelopes.
2. The tube must be mounted by means of its mounting flange.
3. An adequate flow of air must be supplied to maintain the ceramic/metal envelope temperature below the maximum rated value.
4. The maximum permissible peak forward voltage for instantaneous starting is 80kV and there must be no overshoot.
5. The peak inverse voltage including spike must not exceed 20kV for the first 125 microseconds after the anode pulse.
6. For single shot or burst mode applications this parameter can exceed 100kA/ μ s. The ultimate value which can be attained depends to a large extent upon the external circuit.
7. This rate of rise refers to that part of the leading edge of the pulse between 25% and 75% of the pulse amplitude.
8. Measured with respect to cathode. When grid 1 is pulse driven, the last 0.25 μ s of the top of the grid 1 pulse must overlap the corresponding first 0.25 μ s of the top of the delayed grid 2 pulse.
9. The tube may be operated with a loaded grid 2 bias voltage of 0 to -50V provided that care is taken to ensure that the peak grid 1 drive current is sufficiently low to prevent triode firing (tube control by the grid 1 pulse).
10. When d.c. priming is used on grid 1, a negative bias of 100 to 200V must be applied to grid 2 to ensure anode voltage hold-off. D.C. priming is recommended for pulse modulator and crowbar service.
11. D.C. negative bias voltages must not be applied to grid 1. When grid 1 is pulse driven, the potential of grid 1 may vary between -10 and +5V with respect to cathode potential during the period between the completion of recovery and the commencement of the succeeding grid pulse.
12. Typical figures are obtained on test using conditions of minimum grid drive. Improved performance can be expected by increasing grid drive.

13. The time interval between the instant at which the rising unloaded grid 2 pulse reaches 25% of its pulse amplitude and the instant when anode conduction takes place.
14. The drift in delay time over a period from 10 seconds to 10 minutes after reaching full voltage.

X-RAY WARNING

X-rays may be emitted by the CX1199 but the radiation is usually reduced to a safe level by the metal panels of the equipment in which the tube operates.

SCHEMATIC DIAGRAM

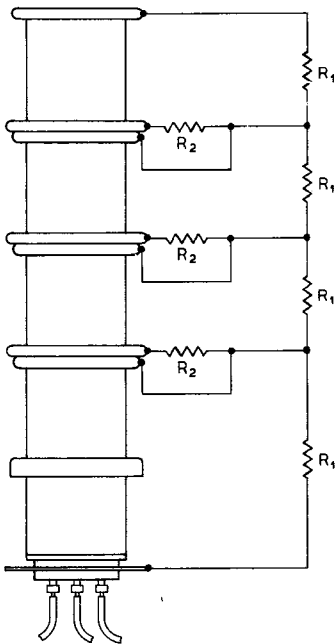

Recommended Values

$R_1 = 10 \text{ to } 20M\Omega$

$R_2 = 470 \text{ to } 1000\Omega$

Please consult EEV for alternative methods of connection.

OUTLINE

3588A

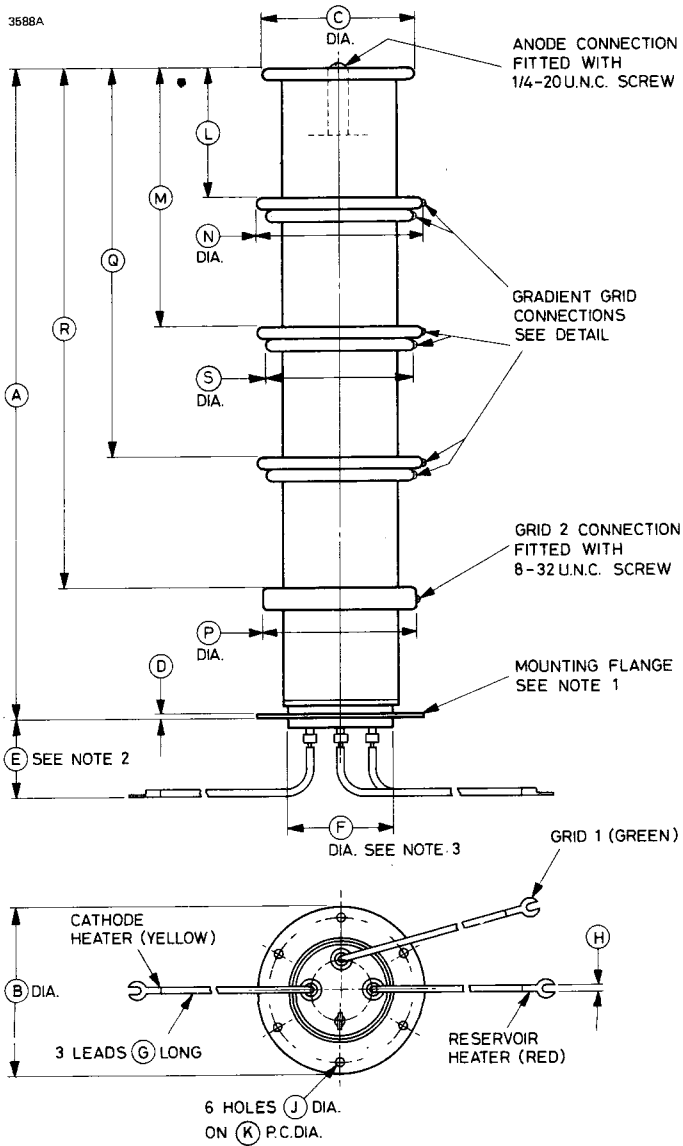

Detail of Gradient Grid Connections

3573A

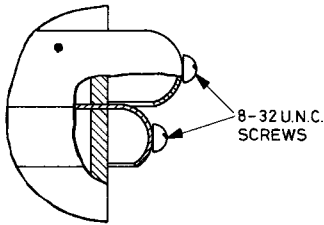

Outline Dimensions (All dimensions without limits are nominal)

Ref	Inches	Millimetres	Ref	Inches	Millimetres
A	16.875 max	428.6 max	K	3.750	95.25
B	4.375	111.1	L	3.375	85.73
C	4.000	101.6	M	6.750	171.5
D	0.100	2.54	N	4.375	111.1
E	2.000 min	50.80 min	P	4.000	101.6
F	2.750 max	69.85 max	Q	10.125	257.2
G	6.000	152.4	R	13.500	342.9
H	0.250	6.35	S	3.625	92.08
J	0.256	6.50			

Millimetre dimensions have been derived from inches except dimension J.

Outline Notes

1. The mounting flange is the connection for the cathode, cathode heater return and reservoir heater return.
2. A minimum clearance of 2.000 inches (50.80mm) must be allowed below the mounting flange.
3. The recommended mounting hole is 2.875 inches (73.03mm) diameter.

Whilst EEV has taken care to ensure the accuracy of the information contained herein it accepts no responsibility for the consequences of any use thereof and also reserves the right to change the specification of goods without notice. EEV accepts no liability beyond that set out in its standard conditions of sale in respect of infringement of third party patents arising from the use of tubes or other devices in accordance with information contained herein.



FOUR-GAP DOUBLE ENDED CERAMIC THYRATRON

The data to be read in conjunction with the Hydrogen Thyatron Preamble.

ABRIDGED DATA

Deuterium-filled, four-gap, double ended high voltage thyatron with ceramic/metal envelope, featuring low jitter, firing time and drift. Suitable for switching high power and for switching long pulses. Reservoirs are incorporated, operating from separate heater supplies. The tube is electrically symmetrical, with identical cathode and grid assemblies at both ends; the flange electrode which is positive when the tube is triggered is referred to as the anode.

Peak forward anode voltage	140	kV max
Peak anode current (see page 2)	3000	A max
Average anode current	3.0	A max
Anode heating factor	60×10^9	V.A.p.p.s. max
Peak output power	175	MW max

GENERAL

Electrical

Cathodes (connected internally to one end of associated heater)		oxide coated
Cathode heater voltage (each end)	$6.3 \pm 5\%$	V
Cathode heater current (each end)	21.5	A
Reservoir heater voltage (each end) (see note 1)	5.0	V
Reservoir heater current (each end)	7.0	A
Tube heating time (minimum)	15	min
Inter-electrode capacitances (each gap)	15 to 20	pF approx

Mechanical

Seated height (flange to flange)	19.250 inches (489.0mm)	nom
Clearance required below flanges	2.000 inches (50.8mm)	min
Overall diameter	4.375 inches (111.1mm)	nom
Net weight	13.2 pounds (6.0kg)	approx
Mounting position (see note 2)		any
Tube connections		see outline

Cooling	forced-air or liquid
Forced-air	see note 3
Liquid	oil or coolant immersion
Maximum temperature of envelope	200 °C

Natural ambient* cooling is usually insufficient to maintain the ceramic/metal envelope temperature below the maximum value specified above. Cooling by oil or coolant immersion is advised in view of the high voltages present. Further information is contained in the relevant section of the Preamble.

PULSE MODULATOR SERVICE (See note 4)

MAXIMUM AND MINIMUM RATINGS (Absolute values)

	Min	Max	
Anode			
Peak forward or inverse anode voltage (see note 5)	—	140	kV
Peak anode current	—	3000	A
Peak anode current (pulse repetition rate limited to 60p.p.s. max)	—	4000	A
Average anode current	—	3.0	A
Rate of rise of anode current (see notes 6 and 7)	—	5000	A/μs
Anode heating factor	—	60 x 10 ⁹	V.A.p.p.s.

Grid 2

Unloaded grid 2 drive pulse voltage (see note 8)	200	1000	V
Grid 2 pulse duration	1.0	—	μs
Rate of rise of grid 2 pulse (see note 6)	1.0	—	kV/μs
Grid 2 pulse delay	0.5	3.0	μs
Peak inverse grid 2 voltage	—	450	V
Loaded grid 2 bias voltage	-50	-200	V
Forward impedance of grid 2 drive circuit	50	1000	Ω

Grid 1 — D.C. Primed (See note 9)

D.C. grid 1 unloaded priming voltage	75	150	V
D.C. grid 1 priming current	25	50	mA

MAXIMUM AND MINIMUM RATINGS — continued

	Min	Max	
Grid 1 — Pulsed (See note 10)			
Unloaded grid 1 drive pulse voltage (see note 8)	300	1000	V
Grid 1 pulse duration	2.0	—	μs
Rate of rise of grid 1 pulse (see note 6)	1.0	—	kV/μs
Peak inverse grid 1 voltage	—	450	V
Loaded grid 1 bias voltage	—	—	see note 11
Peak grid 1 drive current	0.3	1.0	A

Cathodes

Heater voltage	6.3 ± 5%	—	V
Heating time	15	—	min

Reservoirs

Heater voltage (see note 1)	3.5	6.5	V
Heating time	15	—	min

Environmental

Ambient temperature	−50	+90	°C
Altitude	—	10 000	ft
	—	3	km

CHARACTERISTICS

	Min	Typical	Max	
Critical d.c. anode voltage for conduction (see note 12)	—	7.0	10	kV
Anode delay time (see notes 12 and 13)	—	0.1	0.25	μs
Anode delay time drift (see notes 12 and 14)	—	15	50	ns
Time jitter (see note 12)	—	1.0	5.0	ns
Cathode heater current (at 6.3V)	18	21.5	25	A
Reservoir heater current (at 5.0V)	6.0	7.0	9.0	A

RATINGS FOR SINGLE SHOT OR CROWBAR SERVICE (See note 9)

D.C. forward anode voltage	—	120	kV max
Peak anode current	—	15 000	A max
Product of peak current and pulse duration	—	1.0	A.s max
Repetition frequency	—	1 pulse per 10s	max

NOTES

1. The reservoir heaters must be decoupled with suitable capacitors to avoid damage by spike voltages. The recommended voltage for each tube is marked on the tube, and both reservoirs must be operated at the same heater voltage.
2. The tube must be mounted by one of the cathode flanges, with flexible connections to all other electrodes.
3. An adequate flow of air must be supplied to maintain the ceramic/metal envelope temperature below the maximum rated value.
4. Triggered charging techniques are recommended because the tube has a relatively long recovery time (100–200 μ s).
5. This is the maximum hold off voltage in either direction before the tube is triggered. The maximum permissible peak forward voltage for instantaneous starting is 120kV and there must be no overshoot.
6. This rate of rise refers to that part of the leading edge of the pulse between 25% and 75% of the pulse amplitude.
7. For single shot or burst mode applications this parameter can exceed 100kA/ μ s; the ultimate value which can be attained depends upon the external circuit, but the heating factor must be reduced.
8. Measured with respect to the associated cathode. The tube is triggered by pulsing the grid 2 at the negative end, while the grid 2 at the anode (positive) end is connected to its associated cathode and carries most of the forward anode current. When grid 1 is pulse driven, the last 0.25 μ s of the top of the grid 1 pulse must overlap the corresponding first 0.25 μ s of the top of the delayed grid 2 pulse.
9. When d.c. priming is used on grid 1, a negative bias of 100 to 200V must be applied to grid 2 to ensure anode voltage hold-off. D.C. priming of grid 1 at both ends is recommended for crowbar service.
10. When pulse drive is applied to the triggered end of the tube, the grid 1 at the anode (positive) end will normally be d.c. primed.
11. D.C. negative bias voltages must not be applied to grid 1. When grid 1 is pulse driven, the potential of grid 1 may vary between –10 and +5V with respect to cathode during the period between the completion of recovery and the start of the next grid pulse.

OUTLINE

4180

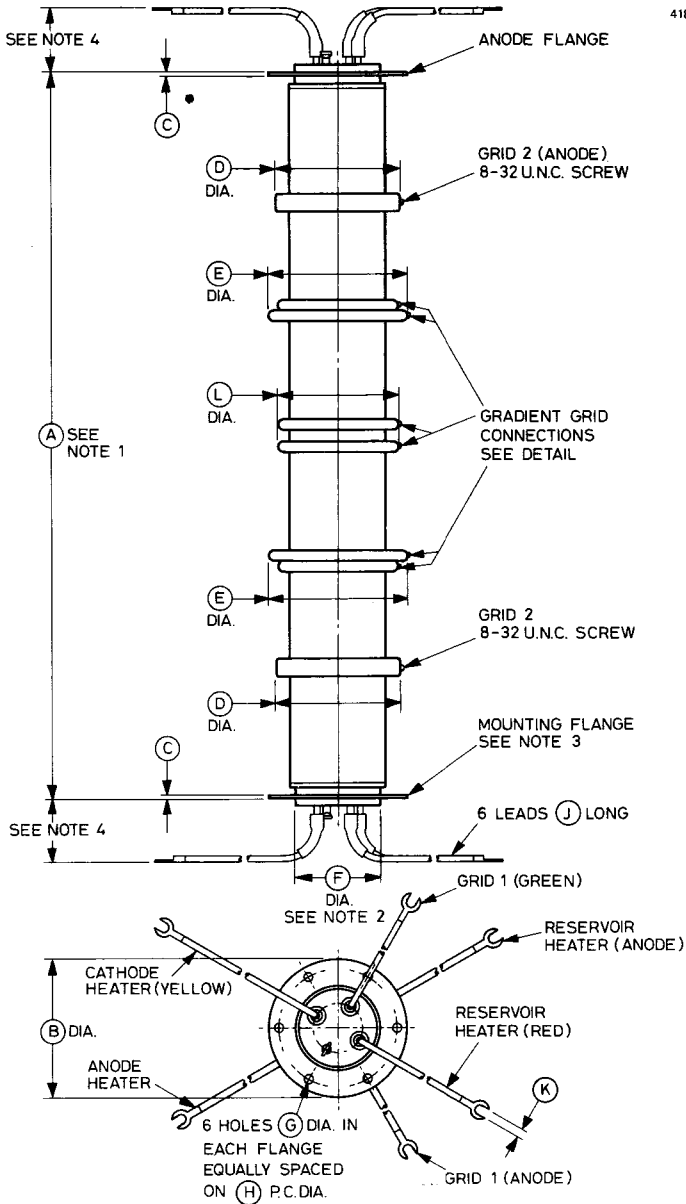

Whilst EEV has taken care to ensure the accuracy of the information contained herein it accepts no responsibility for the consequences of any use thereof and also reserves the right to change the specification of goods without notice. EEV accepts no liability beyond that set out in its standard conditions of sale in respect of infringement of third party patents arising from the use of tubes or other devices in accordance with information contained herein.

Detail of Gradient Grid Connections

3573A

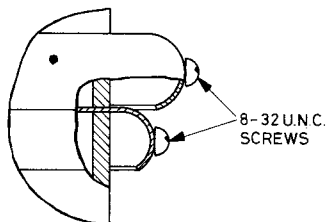

Outline Dimensions (All dimensions without limits are nominal)

Ref	Inches	Millimetres
A	19.250 ± 0.200	488.95 ± 5.08
B	4.375	111.1
C	0.100	2.54
D	4.000 ± 0.062	101.6 ± 1.6
E	4.375 ± 0.062	111.1 ± 1.6
F	2.750 max	69.85 max
G	0.256	6.50
H	3.750	95.25
J	6.000 min	152.4 min
K	0.250	6.35
L	3.625 ± 0.062	92.08 ± 1.57

Millimetre dimensions have been derived from inches.

Outline Notes

1. The two flanges will be parallel within 0.059 inch (1.5mm).
2. The recommended mounting hole is 2.875 inches (73.03mm) diameter.
3. The tube must be mounted by one flange only. The flange is the connection for the cathode, cathode heater return and reservoir heater return.
4. A minimum clearance of 2.000 inches (50.80mm) must be allowed below the flange.



DEUTERIUM FILLED TWO-GAP METAL/CERAMIC THYRATRON

The data to be read in conjunction with the Hydrogen Thyatron Preamble.

ABRIDGED DATA

Deuterium-filled two-gap thyatron with metal/ceramic envelope, suitable for switching high peak and average power at high pulse repetition rates. A reservoir operating from the cathode heater supply is incorporated.

Peak forward anode voltage (see note 5)	70	kV max
Peak anode current (see note 7)	3500	A max
Average anode current	5.0	A max
Anode heating factor	100×10^9	V.A.p.p.s. max
Peak output power	100	MW max
Operating frequency (see note 15)	25	kHz max

GENERAL

Electrical

Cathode	impregnated tungsten
Cathode heater voltage (see note 1)	$6.3 \pm 7.5\%$ V
Cathode heater current	36 A
Reservoir heater voltage (see notes 1 and 2)	$6.3 \pm 7.5\%$ V
Reservoir heater current	5.0 A
Tube heating time (minimum)	5.0 min

Mechanical

Seated height	240 mm (9.448 inches) max
Clearance required below mounting flange	80 mm (3.150 inches) min
Overall diameter (excluding connections)	122 mm (4.803 inches) max
Net weight	3.6 kg (8 pounds) approx
Mounting position	see note 3
Tube connections	see outline

Cooling

The tube may be cooled by forced-air or liquid immersion, depending on operating conditions, to maintain the metal/ceramic envelope below the maximum rated temperature.

In addition to 225 W of heater power, the tube dissipates from 100 W per ampere average anode current, rising to 300 W/A at the highest rates of rise and fall of anode current.

The cathode end of the tube must be cooled whenever heater voltages are applied.

Envelope temperature:

anode, gradient grid, grid 1 and grid 2	250	°C max
cathode flange and end cover	150	°C max

PULSE MODULATOR SERVICE

MAXIMUM AND MINIMUM RATINGS (Absolute values)

	Min	Max	
Anode			
Peak forward anode voltage (see notes 4 and 5)	—	70	kV
Peak inverse anode voltage (see notes 5 and 6)	—	70	kV
Peak anode current (see note 7)	—	3500	A
Average anode current	—	5.0	A
R.M.S. anode current	—	125	A
Rate of rise of anode current (see note 8)	—	10	kA/μs
Anode heating factor	—	100 x 10 ⁹	V.A.p.p.s.

Grid 2

Unloaded grid 2 drive pulse voltage (see note 9)	600	2000	V
Grid 2 pulse duration	1.0	—	μs
Rate of rise of grid 2 pulse (see notes 8 and 10)	4.0	—	kV/μs
Impedance of grid 2 drive circuit (see note 11)	50	250	Ω
D.C. resistance of grid 2 drive circuit	—	500	Ω
Grid 2 negative bias supply voltage	0	120	V

MAXIMUM AND MINIMUM RATINGS – Continued

	Min	Max	
Grid 1 – D.C. primed (see note 12)			
D.C. grid 1 priming current	0.1	2.0	A
D.C. grid 1 voltage drop	15	30	V

Grid 1 – Pulsed (see note 13)			
Unloaded grid 1 drive pulse voltage	300	1000	V
Grid 1 pulse duration	2.0	–	μ s
Rate of rise of grid 1 pulse	1.0	–	kV/ μ s
Peak grid 1 drive current	0.5	2.0	A

Cathode			
Heater voltage	$6.3 \pm 7\frac{1}{2}\%$		V
Heating time	5.0	–	min

Reservoir			
Heater voltage	$6.3 \pm 7\frac{1}{2}\%$		V
Heating time	5.0	–	min

Environmental			
Ambient temperature	–40	+90	$^{\circ}$ C

CHARACTERISTICS

	Min	Typical	Max	
Critical d.c. anode voltage for conduction	–	0.5	2.0	kV
Anode delay time	–	200	250	ns
Anode delay time drift (see note 14)	–	15	25	ns
Time jitter	–	3.0	5.0	ns
Recovery time (see note 16)	–	20	–	μ s
Cathode heater current (at 6.3 V)	30	36	40	A
Reservoir heater current (at 6.3 V)	4.0	5.0	6.0	A

NOTES

1. The reservoir heater can be supplied either from a transformer common to the cathode heater supply or a separate transformer. If a single transformer is used, the reservoir lead must be connected to the mounting flange and the reservoir heater circuit decoupled with a suitable capacitor.

The cathode connection to the load must be adequate to prevent pulse voltages appearing in the heater circuits. At high rates of rise of anode current, the cathode potential may rise significantly at the beginning of the pulse, depending on the cathode lead inductance. The heater transformers must have sufficient insulation to withstand this voltage.

2. The reservoir system of the CX1525 contains a barretter and variations of the reservoir supply voltage within the limits given will not significantly alter the gas pressure.
3. The tube may be mounted in any position provided that the cathode end is lower than the anode.
4. The maximum permissible peak forward voltage for instantaneous starting is 40 kV and there must be no overshoot.
5. For operation at 70 kV, the tube must be liquid immersed. When operated in air, the maximum peak forward or inverse anode voltage must be limited to 50 kV.
6. The peak inverse voltage including spike must not exceed 20 kV for the first 25 μ s after the anode pulse.
7. For pulse durations up to 3 microseconds. For greater pulse durations the peak current must not exceed:—

$$3000 \left[\frac{3}{t_p} \right]^{\frac{1}{2}}$$

where t_p is in microseconds.

8. This rate of rise refers to that part of the leading edge of the pulse between 25% and 75% of the pulse amplitude.
9. Measured with respect to cathode.
10. A lower rate of rise may be used, but this may result in the anode delay time, delay time drift and jitter exceeding the limits quoted.
11. During both the drive pulse period and during recovery when the current flow is reversed.
12. This method of operation limits the transient voltages, which appear at the grids during the rise time of the anode current pulse, to less than 1 kV. It is recommended for applications requiring short rise times or high peak currents.

13. Alternatively, grid 1 may be driven from the grid 2 pulse drive through a $100\ \Omega$ resistance in series with $0.01\ \mu\text{F}$; a $500\ \Omega$ resistor should be connected between grid 1 and cathode.
14. Measured between the fifth minute after the application of h.t. and any subsequent time.
15. The CX1525 has a short recovery time for a tube of its size. For peak forward anode voltages below $40\ \text{kV}$, the tube may be operated as a single gap device without the resistive divider shown on page 5 and with the gradient grid connected to the cathode through a resistor. A $12\ \text{W}$ wire wound resistor in the range 5 to $20\ \Omega$ is suitable. Under these conditions, the gradient grid acts as a screen for the control grid against high rates of rise of anode voltage.
16. Measured after a current pulse of $1000\ \text{A}$, with a grid 2 bias voltage of $-100\ \text{V}$, a recovery impedance of $500\ \Omega$ and a $1.0\ \text{kV}$ anode probe.

X-RAY WARNING

X-rays are emitted by this device. The metal envelope of the CX1525 provides limited protection but further shielding may be required.

GRADIENT GRID CONNECTIONS

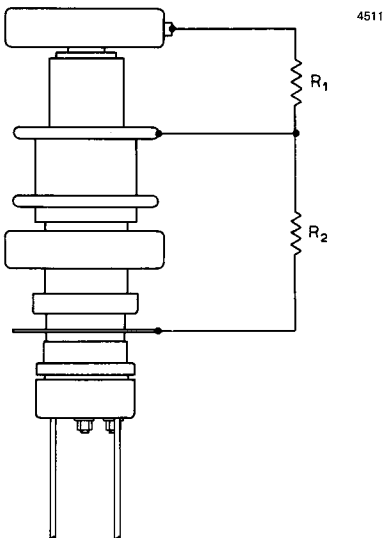

Recommended Values

$$R_1 = R_2 = 10 \text{ to } 20\text{M}\Omega$$

OUTLINE

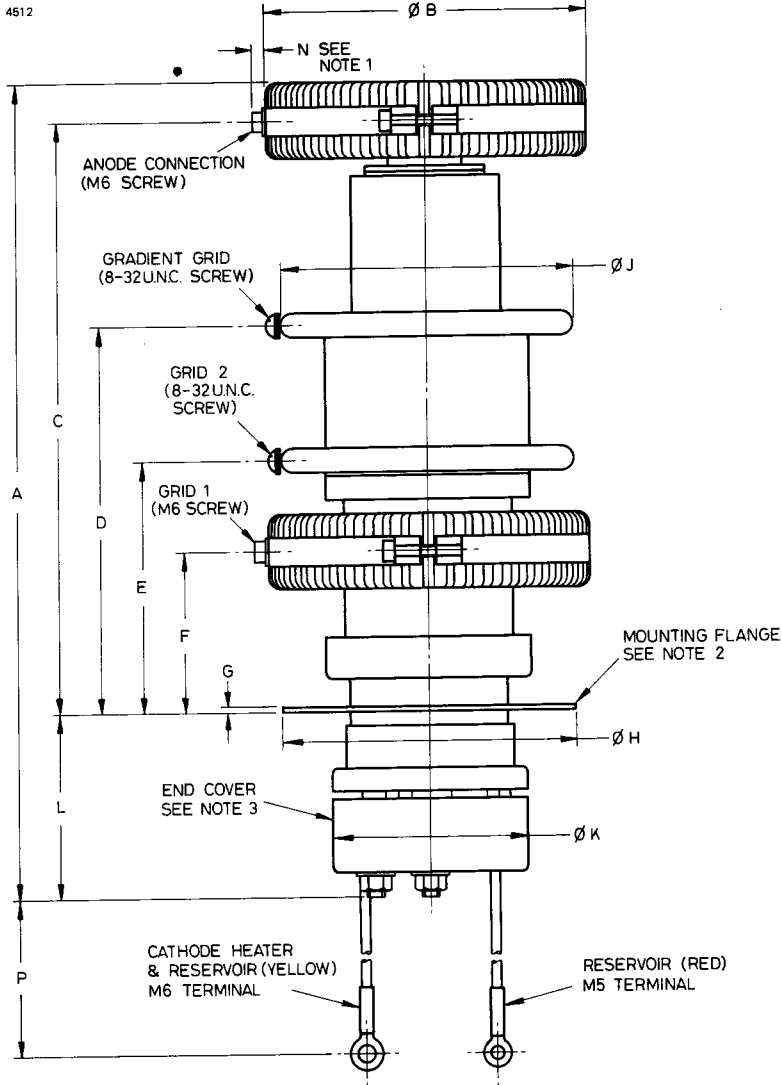

Whilst EEV has taken care to ensure the accuracy of the information contained herein it accepts no responsibility for the consequences of any use thereof and also reserves the right to change the specification of goods without notice. EEV accepts no liability beyond that set out in its standard conditions of sale in respect of infringement of third party patents arising from the use of tubes or other devices in accordance with information contained herein.

Enlarged Detail of Mounting Flange

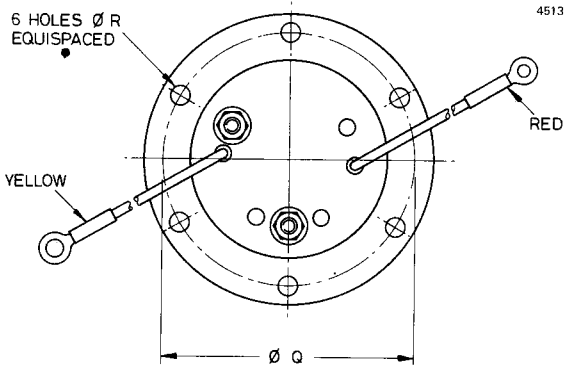

Outline Dimensions (All dimensions without limits are nominal)

Ref	Millimetres	Inches	Ref	Millimetres	Inches
A	300.0 max	11.811 max	J	111.0	4.375
B	122.0 max	4.803 max	K	75.00 max	2.953 max
C	222.7	8.768	L	63.50 max	2.500 max
D	146.0	5.748	N	15.00 max	0.591 max
E	95.00	3.740	P	305.0	12.008
F	61.00	2.402	Q	95.25	3.750
G	2.50	0.100	R	6.50	0.256
H	111.0	4.375			

Inch dimensions have been derived from millimetres.

Outline Notes

1. This dimension also applies to the clamping screws and lugs.
2. The mounting flange is the connection for the cathode and cathode heater return.
3. The end cover is at heater potential and must not be grounded.



CX1526A CX1526B

DEUTERIUM FILLED METAL/CERAMIC THYRATRON

The data to be read in conjunction with the Hydrogen Thyatron Preamble.

ABRIDGED DATA

Deuterium-filled tetrode thyatron with metal/ceramic envelope designed for liquid immersion cooling. The CX1526A is suitable for switching high peak and average power at high pulse repetition rates in pulse modulators and the CX1526B is for inverter service in medium frequency induction heating generators. A reservoir operating from the cathode heater supply is incorporated.

Pulse Modulator Service

Peak forward anode voltage	40	kV max
Peak anode current (see note 6)	3500	A max
Average anode current	5.0	A max
Anode heating factor	70×10^9	V.A.p.p.s. max
Peak output power	70	MW max

Inverter Service

Peak anode voltage	40	kV max
Average anode current	20	A max
Output power (two tubes)	320	kW

GENERAL

Electrical

Cathode	impregnated tungsten
Cathode heater voltage (see note 1)	$6.3 \pm 7.5\%$ V
Cathode heater current	36 A
Reservoir heater voltage (see notes 1 and 2)	$6.3 \pm 7.5\%$ V
Reservoir heater current	5.0 A
Tube heating time (minimum)	5.0 min
Anode to grid 2 capacitance	35 pF

Mechanical

Seated height	210mm (8.268 inches) max
Clearance required below mounting flange	108mm (4.250 inches) min
Overall diameter (excluding connections)	122mm (4.803 inches) max
Net weight	3.4kg (7.5 pounds) approx
Mounting position	see note 3
Tube connections	see outline

Cooling

The tube is designed to be operated totally immersed in a liquid coolant. In pulse modulator service, the tube dissipates 250W of heater power and from 100W per ampere average anode current, rising to 300W/A at the highest rates of rise and fall of anode current. In inverter service, the total tube dissipation at maximum ratings is 2.5 to 3.0kW.

The cathode end of the tube must be cooled whenever heater voltages are applied.

Envelope temperature	100 °C max
--------------------------------	------------

PULSE MODULATOR SERVICE (CX1526A)

MAXIMUM AND MINIMUM RATINGS (Absolute values)

	Min	Max	
Anode			
Peak forward anode voltage (see note 4)	—	40	kV
Peak inverse anode voltage (see note 5)	—	40	kV
Peak anode current (see note 6)	—	3500	A
Average anode current	—	5.0	A
R.M.S. anode current	—	125	A
Rate of rise of anode current (see note 7)	—	10	kA/ μ s
Anode heating factor	—	70×10^9	V.A.p.p.s.

Grid 2

Unloaded grid 2 drive pulse voltage (see note 8)	600	2000	V
Grid 2 pulse duration	2.0	—	μ s
Rate of rise of grid 2 pulse (see notes 7 and 9)	4.0	—	kV/ μ s
Impedance of grid 2 drive circuit (see note 10)	50	250	Ω
D.C. resistance of grid 2 drive circuit	—	500	Ω
Grid 2 negative bias supply voltage	0	120	V

MAXIMUM AND MINIMUM RATINGS – Continued

	Min	Max	
Grid 1 – D.C. primed (see note 11)			
D.C. grid 1 priming current	0.1	2.0	A
D.C. grid 1 voltage drop	15	30	V
Grid 1 – Pulsed (see note 12)			
Unloaded grid 1 drive pulse voltage	300	1000	V
Grid 1 pulse duration	2.0	—	μ s
Rate of rise of grid 1 pulse	1.0	—	kV/ μ s
Peak grid 1 drive current	0.5	2.0	A
Cathode			
Heater voltage	$6.3 \pm 7\frac{1}{2}\%$		V
Heating time	5.0	—	min
Reservoir			
Heater voltage	$6.3 \pm 7\frac{1}{2}\%$		V
Heating time	5.0	—	min
Environmental			
Ambient temperature	—	+70	$^{\circ}$ C

CHARACTERISTICS

	Min	Typical	Max	
Critical d.c. anode voltage for conduction.	—	0.5	1.0	kV
Anode delay time	—	200	250	ns
Anode delay time drift (see note 13)	—	15	25	ns
Time jitter	—	3.0	5.0	ns
Cathode heater current (at 6.3V)	30	36	40	A
Reservoir heater current (at 6.3V)	4.0	5.0	6.0	A

INVERTER SERVICE (CX1526B)

MAXIMUM RATINGS (Absolute values)

Peak forward anode voltage	40	kV max
Peak inverse anode voltage (see note 14)	40	kV max
Average anode current (see note 1)	20	A max
Peak anode current:		
repetitive (see note 15)	40	A max
surge (see note 16)	200	A max
Rate of rise of anode current (see note 7)	1000	A/ μ s max
Rate of fall of anode current	1000	A/ μ s max
Rate of rise of anode voltage	2.0	kV/ μ s max
Operating frequency (see note 17)	6.0	kHz max

CHARACTERISTICS

Anode to cathode arc voltage	90	V
--	----	---

TRIGGERING

	Min	Max	
Unloaded grid 2 drive pulse voltage (see note 8)	400	1000	V
Impedance of grid 2 drive circuit (see note 10)	50	250	Ω
Grid 2 negative bias supply voltage (see note 18)	50	120	V
Grid 2 bias supply source impedance	—	100	Ω
D.C. grid 1 voltage drop	15	30	V
D.C. grid 1 priming current (see note 11)	0.1	2.0	A

NOTES

- The reservoir heater can be supplied either from a transformer common to the cathode heater supply or a separate transformer; if a single transformer is used, the reservoir heater circuit must be decoupled with a suitable capacitor. The cathode connection to the load must be adequate to prevent pulse voltages appearing in the heater circuits. At high rates of rise of anode current, the cathode potential may rise significantly at the beginning of the pulse, depending on the cathode

lead inductance. The heater transformers must have sufficient insulation to withstand this voltage.

In inverter service, it is recommended that the cathode and reservoir heaters be supplied from separate transformers. A tapped heater transformer should be provided enabling the heater to be run at 6.3V during standby periods, and stepped down to 6.1V whenever the average anode current exceeds 10A.

2. The reservoir system of the CX1526 contains a barretter and variations of the reservoir supply voltage within the limits given will not significantly alter the gas pressure.
3. The tube may be mounted in any position provided that the cathode end is lower than the anode.
4. The maximum permissible peak forward voltage for instantaneous starting is 30kV and there must be no overshoot.
5. For pulse modulator service, the peak inverse voltage including spike must not exceed 10kV for the first 25 μ s after the anode pulse.
6. For pulse durations up to 3 microseconds. For greater pulse durations the peak current must not exceed:—

$$3000 \left[\frac{3}{t_p} \right]^{1/2}$$

where t_p is in microseconds.

7. This rate of rise refers to that part of the leading edge of the pulse between 25% and 75% of the pulse amplitude.
8. Measured with respect to cathode.
9. A lower rate of rise may be used, but this may result in the anode delay time, delay time drift and jitter exceeding the limits quoted.
10. During both the drive pulse period and during recovery when the current flow is reversed.
11. This method of operation limits the transient voltages, which appear at the grids during the rise time of the anode current pulse, to less than 1kV. It is recommended for applications requiring short rise times or high peak currents and for inverter use.
12. Alternatively, grid 1 may be driven from the grid 2 pulse drive through a 100 Ω resistance in series with 0.01 μ F; a 500 Ω resistor should be connected between grid 1 and cathode.

13. Measured between the fifth minute after the application of h.t. and any subsequent time.
14. For inverter service the inverse voltage should not exceed 25kV during the 10 μ s period immediately following the cessation of anode conduction. •
15. A spike not exceeding 100A in amplitude, and of approximately 5 μ s duration, is permissible at the start of the current pulse.
16. This rating applies for a maximum duration of 20ms.
17. The time interval from the end of forward conduction to the re-application of forward anode voltage must not be less than 10 μ s.
18. A negative bias supply of 100 to 120V must be applied to the grid immediately at the end of the conduction period, to facilitate recovery. The bias voltage must be maintained for a minimum duration of 50 μ s.

X-RAYS

The metal envelope of the CX1526 reduces emission of X-rays from the tube.

RECOMMENDED TRIGGERING METHODS

The circuit component values indicated in Figs. 1 and 2 are nominal and need not be strictly adhered to.

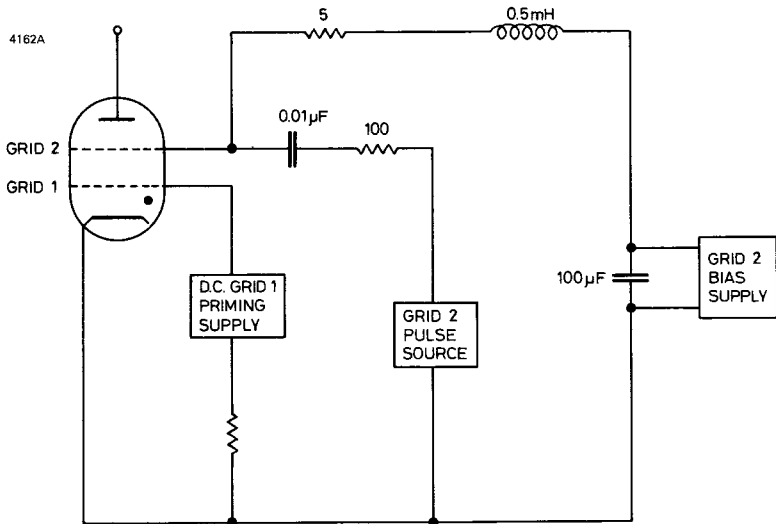

Fig. 1. This is the recommended triggering arrangement, particularly where the tube is to be used at high peak currents, high rates of rise of anode current, or high pulse repetition rates.

RECOMMENDED TRIGGERING METHODS – Continued

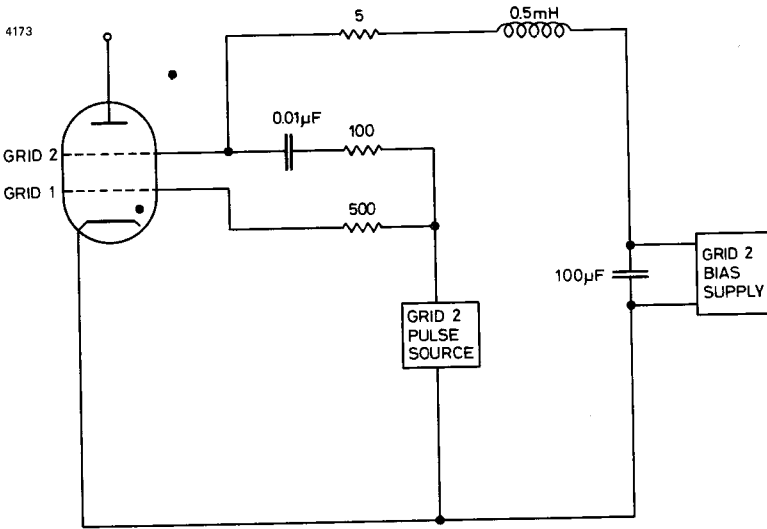

Fig. 2. This alternative triggering arrangement is suitable for operation at high pulse repetition rates. It is not recommended for use at high peak anode currents or high rates of rise of anode current.

OUTLINE DIMENSIONS (All dimensions without limits are nominal)

Ref	Millimetres	Inches	Ref	Millimetres	Inches
A	270.0 max	10.630 max	M	28.00	1.102
B	122.0 max	4.803 max	N	128.5	5.059
C	15.00 max	0.591 max	P	95.50	3.760
D	29.00	1.142	Q	63.50 max	2.500 max
E	56.00 max	2.205 max	R	75.00 max	2.953 max
G	115.0	4.528	T	305.0	12.008
H	43.00	1.693	U	5.60	0.220
J	76.00	2.992	V	85.73	3.375
K	5.00	0.197			

Inch dimensions have been derived from millimetres.

Whilst EEV has taken care to ensure the accuracy of the information contained herein it accepts no responsibility for the consequences of any use thereof and also reserves the right to change the specification of goods without notice. EEV accepts no liability beyond that set out in its standard conditions of sale in respect of infringement of third party patents arising from the use of tubes or other devices in accordance with information contained herein.

OUTLINE

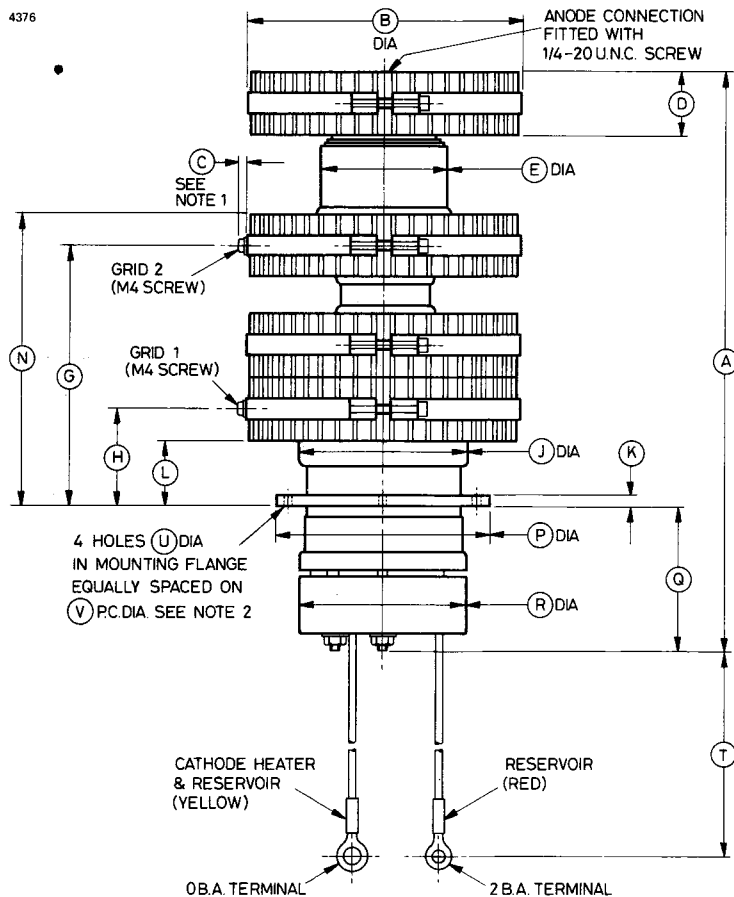

OUTLINE NOTES

1. This dimension also applies to the clamping screws and lugs.
2. The mounting flange is the connection for the cathode and cathode heater return.



CX1527A CX1527B

DEUTERIUM FILLED METAL/CERAMIC THYRATRON

The data to be read in conjunction with the Hydrogen Thyatron Preamble.

ABRIDGED DATA

Deuterium-filled tetrode thyatron with metal/ceramic envelope designed for liquid immersion cooling. The CX1527A is suitable for switching high peak and average power at high pulse repetition rates in pulse modulators and the CX1527B is for inverter service in medium frequency induction heating generators. A reservoir operating from the cathode heater supply is incorporated.

Pulse Modulator Service

Peak forward anode voltage	40	kV max
Peak anode current (see note 6)	10 000	A max
Average anode current	15	A max
Anode heating factor	200×10^9	V.A.p.p.s. max
Peak output power	200	MW max

Inverter Service

Peak anode voltage	40	kV max
Average anode current	60	A max
Output power (two tubes)	1000	kW

GENERAL

Electrical

Cathode	impregnated tungsten
Cathode heater voltage (see note 1)	$6.3 \pm 7.5\%$ V
Cathode heater current	90 A
Reservoir heater voltage (see notes 1 and 2)	$6.3 \pm 7.5\%$ V
Reservoir heater current	8.0 A
Tube heating time (minimum)	10 min
Anode to grid 2 capacitance	80 pF

Mechanical

Seated height	300 mm (11.810 inches) max
Clearance required below mounting flange	75 mm (2.953 inches) min
Overall diameter (excluding connections)	200 mm (7.870 inches) max
Net weight	8 kg (17.6 pounds) approx
Mounting position	see note 3
Tube connections	see outline

Cooling

The tube is designed to be operated totally immersed in a liquid coolant. In pulse modulator service, the tube dissipates 600 W of heater power and from 100 W per ampere average anode current, rising to 300 W/A at the highest rates of rise and fall of anode current. In inverter service, the total tube dissipation at maximum ratings is 7 to 8 kW.

The cathode end of the tube must be cooled whenever heater voltages are applied.

Envelope temperature	100 °C max
--------------------------------	------------

PULSE MODULATOR SERVICE (CX1527A)

MAXIMUM AND MINIMUM RATINGS (Absolute values)

	Min	Max	
Anode			
Peak forward anode voltage (see note 4)	—	40	kV
Peak inverse anode voltage (see note 5)	—	40	kV
Peak anode current (see note 6)	—	10 000	A
Average anode current	—	15	A
R.M.S. anode current	—	350	A
Rate of rise of anode current (see note 7)	—	10	kA/ μ s
Anode heating factor	—	200 x 10 ⁹	V.A.p.p.s.

Grid 2

Unloaded grid 2 drive pulse voltage (see note 8)	600	2000	V
Grid 2 pulse duration	1.0	—	μ s
Rate of rise of grid 2 pulse (see notes 7 and 9)	4.0	—	kV/ μ s
Impedance of grid 2 drive circuit (see note 10)	50	250	Ω
D.C. resistance of grid 2 drive circuit	—	500	Ω
Grid 2 negative bias supply voltage	0	120	V

MAXIMUM AND MINIMUM RATINGS – Continued

	Min	Max	
Grid 1 – D.C. primed (see note 11)			
D.C. grid 1 priming current	0.1	2.0	A
D.C. grid 1 voltage drop	15	30	V

Grid 1 – Pulsed (see note 12)

Unloaded grid 1 drive pulse voltage	300	1000	V
Grid 1 pulse duration	2.0	–	μ s
Rate of rise of grid 1 pulse	1.0	–	kV/ μ s
Peak grid 1 drive current	0.5	2.0	A

Cathode

Heater voltage	$6.3 \pm 7\frac{1}{2}\%$		V
Heating time	10	–	min

Reservoir

Heater voltage	$6.3 \pm 7\frac{1}{2}\%$		V
Heating time	10	–	min

Environmental

Ambient temperature	–	+70	$^{\circ}$ C
-------------------------------	---	-----	--------------

CHARACTERISTICS

	Min	Typical	Max	
Critical d.c. anode voltage				
for conduction	–	0.5	1.0	kV
Anode delay time	–	200	250	ns
Anode delay time drift				
(see note 13)	–	15	25	ns
Time jitter	–	10	15	ns
Cathode heater current (at 6.3 V)	80	90	100	A
Reservoir heater current (at 6.3 V)	6.0	7.0	8.0	A

INVERTER SERVICE (CX1527B)

MAXIMUM RATINGS (Absolute values)

Peak forward anode voltage	40	kV max
Peak inverse anode voltage (see note 14)	40	kV max
Average anode current (see note 1)	60	A max
Peak anode current:		
repetitive (see note 15)	120	A max
surge (see note 16)	600	A max
Rate of rise of anode current (see note 7)	3000	A/ μ s max
Rate of fall of anode current	3000	A/ μ s max
Rate of rise of anode voltage	2.0	kV/ μ s max
Operating frequency (see note 17)	6.0	kHz max

CHARACTERISTICS

Anode to cathode arc voltage	90	V
--	----	---

TRIGGERING

	Min	Max	
Unloaded grid 2 drive pulse voltage (see note 8)	400	1000	V
Impedance of grid 2 drive circuit (see note 10)	50	250	Ω
Grid 2 negative bias supply voltage (see note 18)	50	120	V
Grid 2 bias supply source impedance	—	100	Ω
D.C. grid 1 voltage drop	15	30	V

NOTES

1. The reservoir heater can be supplied either from a transformer common to the cathode heater supply or a separate transformer. If a single transformer is used, the reservoir lead should be connected to the mounting flange and the reservoir heater circuit decoupled with a suitable capacitor.

The cathode connection to the load must be adequate to prevent pulse voltages appearing in the heater circuits. At high rates of rise of anode

current, the cathode potential may rise significantly at the beginning of the pulse, depending on the cathode lead inductance. The heater transformers must have sufficient insulation to withstand this voltage.

In inverter service, it is recommended that the cathode and reservoir heaters be supplied from separate transformers. A tapped heater transformer should be provided enabling the heater to be run at 6.3 V during standby periods, and stepped down to 6.0 V whenever the average anode current exceeds 30 A.

2. The reservoir system of the CX1527 contains a barretter and variations of the reservoir supply voltage within the limits given will not significantly alter the gas pressure.
3. The tube may be mounted in any position provided that the cathode end is lower than the anode.
4. The maximum permissible peak forward voltage for instantaneous starting is 30 kV and there must be no overshoot.
5. For pulse modulator service, the peak inverse voltage including spike must not exceed 15 kV for the first 25 μ s after the anode pulse.
6. For pulse durations up to 3 microseconds. For greater pulse durations the peak current must not exceed:—

$$10\,000 \left[\frac{3}{t_p} \right]^{\frac{1}{2}}$$

where t_p is in microseconds.

7. This rate of rise refers to that part of the leading edge of the pulse between 25% and 75% of the pulse amplitude.
8. Measured with respect to cathode.
9. A lower rate of rise may be used, but this may result in the anode delay time, delay time drift and jitter exceeding the limits quoted.
10. During both the drive pulse period and during recovery when the current flow is reversed.
11. This method of operation reduces the transient voltages which appear at the grids during the rise time of the anode current pulse. It is recommended for applications requiring short rise times or high peak currents.
12. Alternatively, grid 1 may be driven from the grid 2 pulse drive through a 100 Ω resistance in series with 0.01 μ F; a 500 Ω resistor should be connected between grid 1 and cathode.

13. Measured between the fifth minute after the application of h.t. and any subsequent time.
14. For inverter service the inverse voltage should not exceed 25 kV during the 10 μ s period immediately following the cessation of anode conduction. •
15. A spike not exceeding 300 A in amplitude, and of approximately 5 μ s duration, is permissible at the start of the current pulse.
16. This rating applies for a maximum duration of 20 ms.
17. The time interval from the end of forward conduction to the re-application of forward anode voltage must not be less than 10 μ s.
18. A negative bias supply of 100 to 120 V must be applied to the grid immediately at the end of the conduction period, to facilitate recovery. The bias voltage must be maintained for a minimum duration of 50 μ s.

X-Ray Warning

X-rays are emitted by this device. The metal envelope of the CX1527 provides limited protection but further shielding may be required.

OUTLINE DIMENSIONS (All dimensions without limits are nominal)

Ref	Millimetres	Inches	Ref	Millimetres	Inches
A	360.0 max	14.173 max	J	148.0	5.827
B	200.0 max	7.874 max	K	3.15	0.124
C	15.00 max	0.591 max	L	57.00 max	2.244 max
D	8.00	0.315	M	9.53	0.375
E	135.7	5.343	N	152.4	6.000
F	78.00 max	3.071 max	P	120.0 max	4.724 max
G	270.0	10.630	Q	305.0 min	12.008 min
H	195.0	7.677			

Inch dimensions have been derived from millimetres except dimensions M and N.

Whilst EEV has taken care to ensure the accuracy of the information contained herein it accepts no responsibility for the consequences of any use thereof and also reserves the right to change the specification of goods without notice. EEV accepts no liability beyond that set out in its standard conditions of sale in respect of infringement of third party patents arising from the use of tubes or other devices in accordance with information contained herein.

OUTLINE

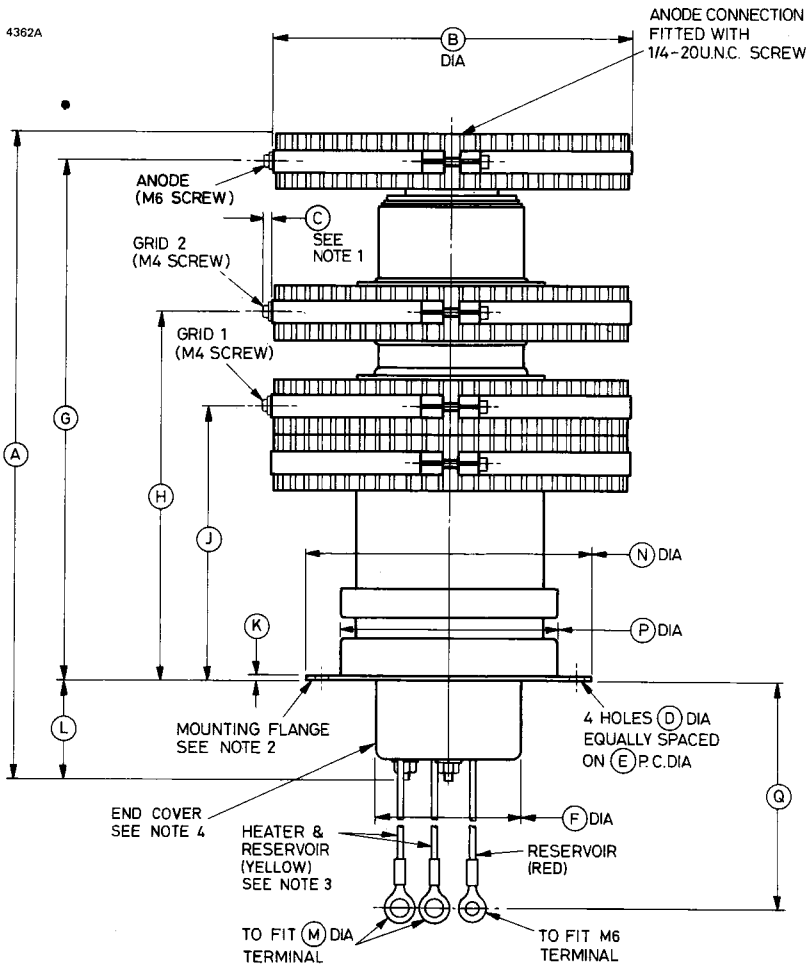

OUTLINE NOTES

1. This dimension also applies to the clamping screws and lugs.
2. The mounting flange is the connection for the cathode and cathode heater return.
3. These two leads must be connected in parallel to the same terminal of the heater transformer.
4. The end cover is at heater potential and must not be grounded.



DEUTERIUM FILLED METAL/CERAMIC THYRATRON

The data to be read in conjunction with the Hydrogen Thyatron Preamble.

ABRIDGED DATA

Deuterium-filled tetrode thyatron with metal/ceramic envelope, suitable for switching high peak and average power at high pulse repetition rates. A reservoir operating from the cathode heater supply is incorporated.

Peak forward anode voltage	40	kV max
Peak anode current (see note 7)	3500	A max
Average anode current	5.0	A max
Anode heating factor	70×10^9	V.A.p.s. max
Peak output power	70	MW max

GENERAL

Electrical

Cathode	Impregnated tungsten	
Cathode heater voltage (see note 1)	$6.3 \pm 7.5\%$	V
Cathode heater current	36	A
Reservoir heater voltage (see notes 1 and 2)	$6.3 \pm 7.5\%$	V
Reservoir heater current	5.0	A
Tube heating time (minimum)	5.0	min
Anode to grid 2 capacitance	35	pF

Mechanical

Seated height	240 mm (9.448 inches) max
Clearance required below mounting flange	80 mm (3.150 inches) min
Overall diameter (excluding connections)	122 mm (4.803 inches) max
Net weight	3.6 kg (8 pounds) approx
Mounting position	see note 3
Tube connections	see outline

Cooling

The tube may be cooled by forced-air or liquid immersion, depending on operating conditions, to maintain the metal/ceramic envelope below the maximum rated temperature.

In addition to 225 W of heater power, the tube dissipates from 100 W per ampere average anode current, rising to 300 W/A at the highest rates of rise and fall of anode current.

The cathode end of the tube must be cooled whenever heater voltages are applied.

Envelope temperature:

anode, grid 1 and grid 2	250	°C max
cathode flange and end cover	150	°C max

PULSE MODULATOR SERVICE

MAXIMUM AND MINIMUM RATINGS (Absolute values)

	Min	Max	
Anode			
Peak forward anode voltage (see notes 4 and 5)	—	40	kV
Peak inverse anode voltage (see notes 5 and 6)	—	40	kV
Peak anode current (see note 7)	—	3500	A
Average anode current	—	5.0	A
R.M.S. anode current	—	125	A
Rate of rise of anode current (see note 8)	—	10	kA/ μ s
Anode heating factor	—	70×10^9	V.A.p.p.s.

Grid 2

Unloaded grid 2 drive pulse voltage (see note 9)	600	2000	V
Grid 2 pulse duration	1.0	—	μ s
Rate of rise of grid 2 pulse (see notes 8 and 10)	4.0	—	kV/ μ s
Impedance of grid 2 drive circuit (see note 11)	50	250	Ω
D.C. resistance of grid 2 drive circuit	—	500	Ω
Grid 2 negative bias supply voltage	0	120	V

MAXIMUM AND MINIMUM RATINGS — Continued

	Min	Max	
Grid 1 — D.C. primed (see note 12)			
D.C. grid 1 priming current	0.1	2.0	A
D.C. grid 1 voltage drop	15	30	V

Grid 1 — Pulsed (see note 13)

Unloaded grid 1 drive pulse voltage	300	1000	V
Grid 1 pulse duration	2.0	—	μ s
Rate of rise of grid 1 pulse	1.0	—	kV/ μ s
Peak grid 1 drive current	0.5	2.0	A

Cathode

Heater voltage	$6.3 \pm 7\frac{1}{2}\%$		V
Heating time	5.0	—	min

Reservoir

Heater voltage	$6.3 \pm 7\frac{1}{2}\%$		V
Heating time	5.0	—	min

Environmental

Ambient temperature	—40	+90	$^{\circ}$ C
-------------------------------	-----	-----	--------------

CHARACTERISTICS

	Min	Typical	Max	
Critical d.c. anode voltage for conduction	—	0.5	1.0	kV
Anode delay time	—	200	250	ns
Anode delay time drift (see note 14)	—	15	25	ns
Time jitter	—	3.0	5.0	ns
Cathode heater current (at 6.3 V)	30	36	40	A
Reservoir heater current (at 6.3 V)	4.0	5.0	6.0	A

NOTES

1. The reservoir heater can be supplied either from a transformer common to the cathode heater supply or a separate transformer. If a single transformer is used, the reservoir lead should be connected to the mounting flange and the reservoir heater circuit decoupled with a suitable capacitor.

The cathode connection to the load must be adequate to prevent pulse voltages appearing in the heater circuits. At high rates of rise of anode current, the cathode potential may rise significantly at the beginning of the pulse, depending on the cathode lead inductance. The heater transformers must have sufficient insulation to withstand this voltage.

2. The reservoir system of the CX1528 contains a barretter and variations of the reservoir supply voltage within the limits given will not significantly alter the gas pressure.
3. The tube may be mounted in any position provided that the cathode end is lower than the anode.
4. The maximum permissible peak forward voltage for instantaneous starting is 30 kV and there must be no overshoot.
5. When both forward and inverse voltages are present the peak to peak voltage must not exceed 50 kV in air at N.T.P. or 80 kV if the tube is oil immersed.
6. The peak inverse voltage including spike must not exceed 10 kV for the first 25 μ s after the anode pulse.
7. For pulse durations up to 3 microseconds. For greater pulse durations the peak current must not exceed:—

$$3000 \left[\frac{3}{t_p} \right]^{1/2}$$

where t_p is in microseconds.

8. This rate of rise refers to that part of the leading edge of the pulse between 25% and 75% of the pulse amplitude.
9. Measured with respect to cathode.
10. A lower rate of rise may be used, but this may result in the anode delay time, delay time drift and jitter exceeding the limits quoted.

11. During both the drive pulse period and during recovery when the current flow is reversed.
12. This method of operation reduces the transient voltages which appear at the grids during the rise time of the anode current pulse. It is recommended for applications requiring short rise times or high peak currents.
13. Alternatively, grid 1 may be driven from the grid 2 pulse drive through a $100\ \Omega$ resistance in series with $0.01\ \mu\text{F}$; a $500\ \Omega$ resistor should be connected between grid 1 and cathode.
14. Measured between the fifth minute after the application of h.t. and any subsequent time.

X-RAY WARNING

X-rays are emitted by this device. The metal envelope of the CX1528 provides limited protection but further shielding may be required.

OUTLINE

4342A

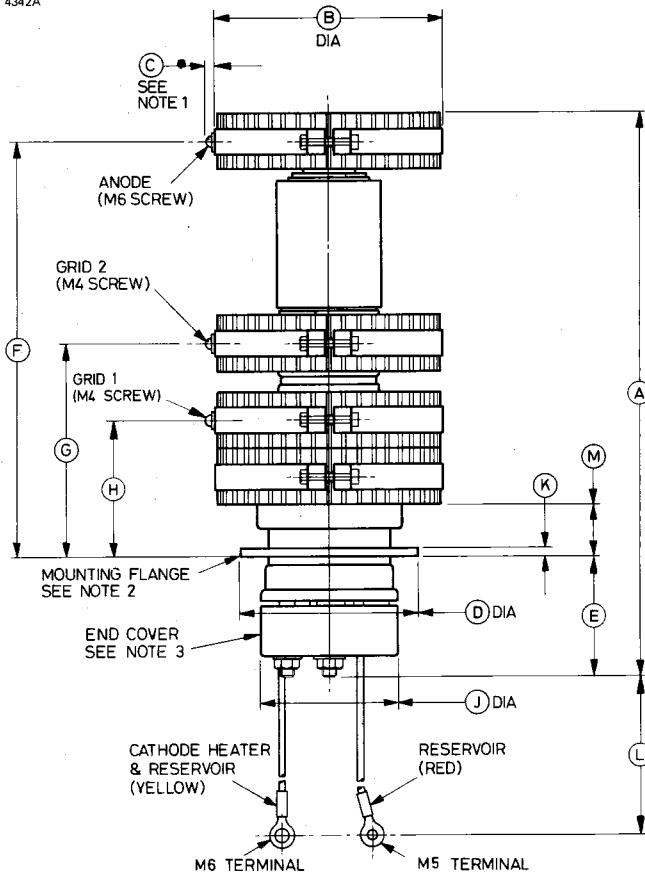

OUTLINE NOTES

1. This dimension also applies to the clamping screws and lugs.
2. The mounting flange is the connection for the cathode and cathode heater return.
3. The end cover is at heater potential and must not be grounded.

Enlarged Detail of Mounting Flange

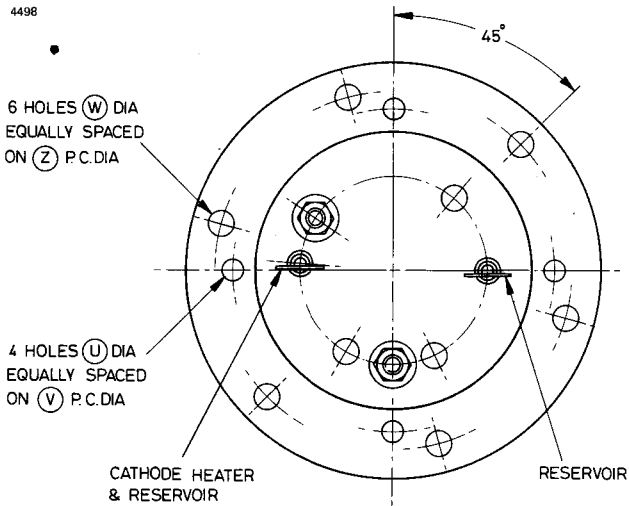

Outline Dimensions (All dimensions without limits are nominal)

Ref	Millimetres	Inches	Ref	Millimetres	Inches
A	300.0 max	11.811 max	J	75.00 max	2.953 max
B	122.0 max	4.803 max	K	2.50	0.100
C	15.00 max	0.591 max	L	305.0	12.008
D	111.0	4.375	M	28.00	1.102
E	63.50 max	2.500 max	U	5.60	0.220
F	215.0	8.465	V	85.73	3.375
G	113.0	4.449	W	6.50	0.256
H	72.00	2.834	Z	95.25	3.750

Inch dimensions have been derived from millimetres.

Whilst EEV has taken care to ensure the accuracy of the information contained herein it accepts no responsibility for the consequences of any use thereof and also reserves the right to change the specification of goods without notice. EEV accepts no liability beyond that set out in its standard conditions of sale in respect of infringement of third party patents arising from the use of tubes or other devices in accordance with information contained herein.



DEUTERIUM FILLED METAL/CERAMIC THYRATRON

The data to be read in conjunction with the Hydrogen Thyatron Preamble.

ABRIDGED DATA

Deuterium-filled tetrode thyatron with metal/ceramic envelope, suitable for switching high peak and average power at high pulse repetition rates. A reservoir operating from the cathode heater supply is incorporated.

Peak forward anode voltage	40	kV max
Peak anode current (see note 7)	10 000	A max
Average anode current	15	A max
Anode heating factor	200×10^9	V.A.p.p.s. max
Peak output power	200	MW max

GENERAL

Electrical

Cathode	impregnated tungsten
Cathode heater voltage (see note 1)	$6.3 \pm 7.5\%$ V
Cathode heater current	90 A
Reservoir heater voltage (see notes 1 and 2)	$6.3 \pm 7.5\%$ V
Reservoir heater current	7.0 A
Tube heating time (minimum)	10 min
Anode to grid 2 capacitance	80 pF

Mechanical

Seated height	315 mm (12.400 inches) max
Clearance required below mounting flange	75 mm (2.953 inches) min
Overall diameter (excluding connections)	200 mm (7.870 inches) max
Net weight	8 kg (17.6 pounds) approx
Mounting position	see note 3
Tube connections	see outline

Cooling

The tube may be cooled by forced-air or liquid immersion, depending on operating conditions, to maintain the metal/ceramic envelope below the maximum rated temperature.

In addition to 600 W of heater power, the tube dissipates from 100 W per ampere average anode current, rising to 300 W/A at the highest rates of rise and fall of anode current.

The cathode end of the tube must be cooled whenever heater voltages are applied.

When forced-air cooling of the anode is required it should be directed into the tubular anode terminal. At maximum ratings an airflow of 100 ft³/min at 2 inches w.g. is suitable. Further information is contained in the relevant section of the Preamble.

Envelope temperature:

anode, grid 1 and grid 2	250	°C max
cathode flange and end cover	150	°C max

PULSE MODULATOR SERVICE

MAXIMUM AND MINIMUM RATINGS (Absolute values)

	Min	Max	
Anode			
Peak forward anode voltage (see notes 4 and 5)	—	40	kV
Peak inverse anode voltage (see notes 5 and 6)	—	40	kV
Peak anode current (see note 7)	—	10 000	A
Average anode current	—	15	A
R.M.S. anode current	—	350	A
Rate of rise of anode current (see note 8)	—	10	kA/μs
Anode heating factor	—	200 x 10 ⁹	V.A.p.p.s.

Grid 2

Unloaded grid 2 drive pulse voltage (see note 9)	600	2000	V
Grid 2 pulse duration	1.0	—	μs
Rate of rise of grid 2 pulse (see notes 8 and 10)	4.0	—	kV/μs
Impedance of grid 2 drive circuit (see note 11)	50	250	Ω
D.C. resistance of grid 2 drive circuit	—	500	Ω
Grid 2 negative bias supply voltage	0	120	V

MAXIMUM AND MINIMUM RATINGS – Continued

	Min	Max	
Grid 1 – D.C. primed (see note 12)			
D.C. grid 1 priming current	0.1	2.0	A
D.C. grid 1 voltage drop	15	30	V
Grid 1 – Pulsed (see note 13)			
Unloaded grid 1 drive pulse voltage	300	1000	V
Grid 1 pulse duration	2.0	–	μ s
Rate of rise of grid 1 pulse	1.0	–	kV/ μ s
Peak grid 1 drive current	0.5	2.0	A
Cathode			
Heater voltage	$6.3 \pm 7\frac{1}{2}\%$		V
Heating time	10	–	min
Reservoir			
Heater voltage	$6.3 \pm 7\frac{1}{2}\%$		V
Heating time	10	–	min
Environmental			
Ambient temperature	–40	+90	$^{\circ}$ C

CHARACTERISTICS

	Min	Typical	Max	
Critical d.c. anode voltage for conduction	–	0.5	1.0	kV
Anode delay time	–	200	250	ns
Anode delay time drift (see note 14)	–	15	25	ns
Time jitter	–	10	15	ns
Cathode heater current (at 6.3 V)	80	90	100	A
Reservoir heater current (at 6.3 V)	6.0	7.0	8.0	A

NOTES

1. The reservoir heater can be supplied either from a transformer common to the cathode heater supply or a separate transformer. If a single transformer is used, the reservoir lead should be connected to the mounting flange and the reservoir heater circuit decoupled with a suitable capacitor.

The cathode connection to the load must be adequate to prevent pulse voltages appearing in the heater circuits. At high rates of rise of anode current, the cathode potential may rise significantly at the beginning of the pulse, depending on the cathode lead inductance. The heater transformers must have sufficient insulation to withstand this voltage.

2. The reservoir system of the CX1529 contains a barretter and variations of the reservoir supply voltage within the limits given will not significantly alter the gas pressure.
3. The tube may be mounted in any position provided that the cathode end is lower than the anode.
4. The maximum permissible peak forward voltage for instantaneous starting is 30 kV and there must be no overshoot.
5. When both forward and inverse voltages are present the peak to peak voltage must not exceed 60 kV in air at N.T.P. or 80 kV if the tube is oil immersed.
6. The peak inverse voltage including spike must not exceed 15 kV for the first 25 μ s after the anode pulse.
7. For pulse durations up to 3 microseconds. For greater pulse durations the peak current must not exceed: –

$$10\,000 \left[\frac{3}{t_p} \right]^{\frac{1}{2}}$$

where t_p is in microseconds.

8. This rate of rise refers to that part of the leading edge of the pulse between 25% and 75% of the pulse amplitude.
9. Measured with respect to cathode.

10. A lower rate of rise may be used, but this may result in the anode delay time, delay time drift and jitter exceeding the limits quoted.
11. During both the drive pulse period and during recovery when the current flow is reversed.
12. This method of operation reduces the transient voltages which appear at the grids during the rise time of the anode current pulse. It is recommended for applications requiring short rise times or high peak currents.
13. Alternatively, grid 1 may be driven from the grid 2 pulse drive through a $100\ \Omega$ resistance in series with $0.01\ \mu\text{F}$; a $500\ \Omega$ resistor should be connected between grid 1 and cathode.
14. Measured between the fifth minute after the application of h.t. and any subsequent time.

X-RAY WARNING

X-rays are emitted by this device. The metal envelope of the CX1529 provides limited protection but further shielding may be required.

OUTLINE

41638

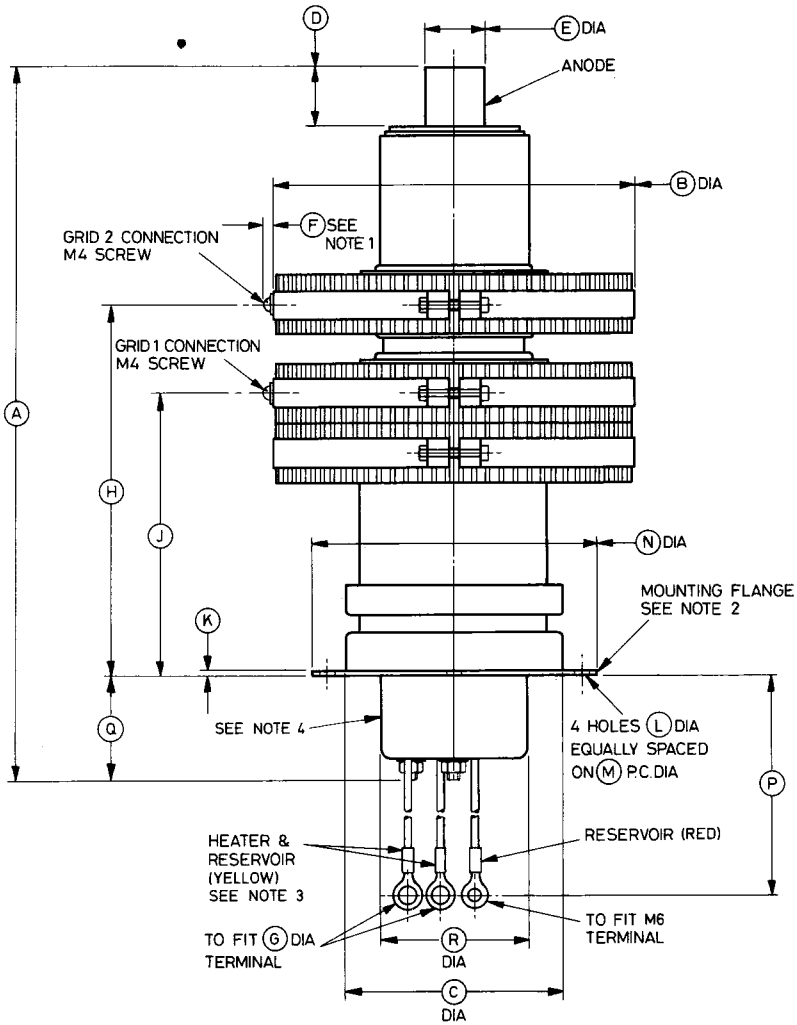

OUTLINE DIMENSIONS (All dimensions without limits are nominal)

Ref	Millimetres	Inches
A	375.0 max	14.764 max
B	200.0 max	7.874 max
C	120.0 max	4.724 max
D	30.0 max	1.181 max
E	31.75 ± 0.15	1.250 ± 0.006
F	15.0 max	0.591 max
G	9.53	0.375
H	198.0 ± 5.0	7.795 ± 0.197
J	148.0 ± 5.0	5.827 ± 0.197
K	3.15	0.124
L	8.00	0.315
M	135.7	5.343
N	152.4	6.000
P	305.0 min	12.008 min
Q	57.0 max	2.244 max
R	78.0 max	3.071 max

Inch dimensions have been derived from millimetres except dimensions G and N.

OUTLINE NOTES

1. This dimension also applies to the clamping screws and lugs.
2. The mounting flange is the connection for the cathode and cathode heater return.
3. These two leads must be connected in parallel to the same terminal of the heater transformer.
4. The end cover is at heater potential and must not be grounded.

Whilst EEV has taken care to ensure the accuracy of the information contained herein it accepts no responsibility for the consequences of any use thereof and also reserves the right to change the specification of goods without notice. EEV accepts no liability beyond that set out in its standard conditions of sale in respect of infringement of third party patents arising from the use of tubes or other devices in accordance with information contained herein.



CX1535

HYDROGEN-FILLED TRIPLE GRID CERAMIC THYRATRON

The data to be read in conjunction with the Hydrogen Thyatron Preamble.

ABRIDGED DATA

Hydrogen-filled triple grid (pentode) thyatron with ceramic/metal envelope, featuring low jitter, firing time and drift. The third grid makes the tube suitable for high power switching at very high repetition rates and permits a very short anode circuit recharge time. A hydrogen reservoir is incorporated together with an automatic current control, giving precise gas control inside the thyatron over wide variations of reservoir voltage.

Peak forward anode voltage	25	kV max
Peak anode current	1000	A max
Average anode current	1.25	A max
Anode heating factor	500×10^9	V.A.p.p.s. max
Peak output power	12.5	MW max
Pulse repetition frequency	100	kHz max

GENERAL

Electrical

Cathode (connected internally to one end of heater)	barium aluminate
Cathode and reservoir heater voltage (see note 1)	$6.3 \pm 7.5\%$ V
Cathode and reservoir heater current	25 A
Tube heating time (minimum)	5.0 min
Anode to grid 2 capacitance (see note 2)	<1.0 pF
Grid input capacitance (see note 3)	40 pF

Mechanical

Seated height	139.7mm (5.500 inches) max
Clearance required below mounting flange	38.0mm (1.496 inches) min
Overall diameter (mounting flange)	88.9mm (3.500 inches) nom
Net weight	1.5kg (3.3 pounds) approx
Mounting position (see note 4)	any
Tube connections	see outline

Cooling

The tube is designed to be operated totally immersed in a liquid coolant.

Maximum temperature of envelope 150 °C

Further information is contained in the relevant section of the Preamble.

PULSE MODULATOR SERVICE

MAXIMUM AND MINIMUM RATINGS (Absolute values)

	Min	Max	
Anode			
Peak forward anode voltage (see note 5)	—	25	kV
Peak inverse anode voltage (see note 6)	—	25	kV
Peak anode current	—	1000	A
Average anode current	—	1.25	A
Rate of rise of anode current (see note 7)	—	5000	A/ μ s
Anode heating factor	—	500×10^9	V.A.p.p.s.

Grid 3

Grid 3 to cathode resistor (see R_{G3} in Fig. 1)	5.0	100	Ω
--	-----	-----	----------

Grid 2

Unloaded grid 2 drive pulse voltage (see note 8)	300	1000	V
Grid 2 pulse duration	0.5	—	μ s
Rate of rise of grid 2 pulse (see note 7)	3.0	—	kV/ μ s
Grid 2 pulse delay (see note 8)	0.5	—	μ s
Peak inverse grid 2 voltage	—	450	V
Loaded grid 2 bias voltage	-50	-200	V
Forward impedance of grid 2 drive circuit	50	250	Ω

Grid 1 — D.C. Primed

D.C. grid 1 unloaded priming voltage	75	150	V
D.C. grid 1 priming current	50	150	mA

MAXIMUM AND MINIMUM RATINGS — continued

	Min	Max	
Grid 1 — Pulsed (See note 9)			
Unloaded grid 1 drive pulse voltage (see note 8)	300	1000	V
Grid 1 pulse duration	2.0	—	μ s
Rate of rise of grid 1 pulse (see note 7)	1.0	—	kV/ μ s
Peak inverse grid 1 voltage	—	450	V
Loaded grid 1 bias voltage			see note 10
Peak grid 1 drive current	0.3	1.0	A
Cathode and Reservoir			
Heater voltage		$6.3 \pm 7.5\%$	V
Heating time	5.0	—	min
Environmental			
Ambient temperature	-50	+110	$^{\circ}$ C

CHARACTERISTICS

	Min	Typical	Max	
Critical d.c. anode voltage for conduction (see note 11)	—	0.5	2.0	kV
Anode delay time (see notes 11 and 12)	—	0.2	0.3	μ s
Anode delay time drift (see notes 11 and 13)	—	20	45	ns
Time jitter (see note 11)	—	3.0	7.0	ns
Cathode and reservoir heater current (at 6.3V)	20	22.5	25	A
Pulse repetition frequency (see note 14)	—	75	100	kHz

NOTES

1. The reservoir heater can be supplied from the same transformer as the cathode heater or from a separate transformer. In either case it must be decoupled with a 0.5μ F paper capacitor in parallel with a 1000pF silvered mica capacitor, or capacitors with comparable performance.

2. The anode to grid 2 capacitance is measured with grid 3 connected to cathode.
3. The input capacitance is the capacitance between grid 1 and grid 2 connected together and grid 3 and cathode connected together. It must be taken into account in trigger circuit design since it loads the trigger drive pulse.
4. The tube must be mounted by means of its mounting flange.
5. The maximum permissible peak forward voltage for instantaneous starting is 20kV and there must be no overshoot.
6. The peak inverse voltage including spike must not exceed 20kV for the first 25 microseconds after the anode pulse.
7. This rate of rise refers to that part of the leading edge of the pulse between 25% and 75% of the pulse amplitude.
8. Measured with respect to cathode. When grid 1 is pulse driven, the last 0.25 μ s of the top of the grid 1 pulse must overlap the corresponding first 0.25 μ s of the top of the delayed grid 2 pulse.
9. Grid 1 may also be driven from grid 2 through a resistor–capacitor network as shown in Fig. 1, but with a consequent reduction in performance in respect of jitter, anode delay time and anode delay time drift.

4341

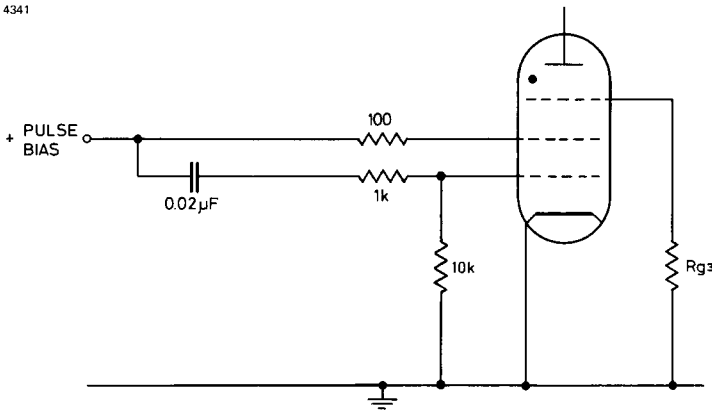

Fig. 1 Single-pulse drive circuit.

10. D.C. negative bias voltages must not be applied to grid 1. When grid 1 is pulse driven, the potential of grid 1 may vary between -10 and $+5V$ with respect to cathode potential during the period between the completion of recovery and the commencement of the succeeding grid pulse.
11. Typical figures are obtained on test using conditions of minimum grid drive. Improved performance can be expected by increasing grid drive.
12. The time interval between the instant at which the rising unloaded grid 2 pulse reaches 25% of its pulse amplitude and the instant when anode conduction takes place.
13. The drift in delay time over a period from 2 minutes to 10 minutes after reaching full voltage.
14. Advice on operation at high pulse repetition frequencies is available from English Electric Valve Company Limited.

X-RAY WARNING

X-rays may be emitted by the CX1535 but the radiation is usually reduced to a safe level by the steel panels of the equipment in which the tube operates.

OUTLINE

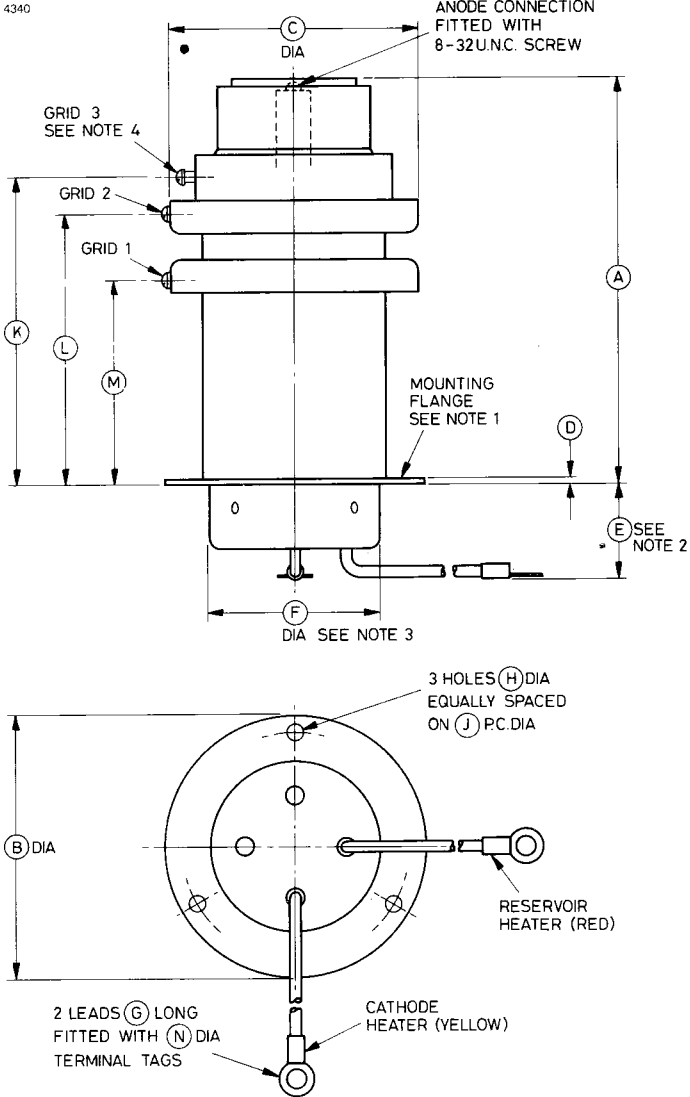

Outline Dimensions

Ref	Millimetres	Inches
A •	136.5 ± 3.2	5.374 ± 0.126
B	88.90 ± 0.25	3.500 ± 0.010
C	83.0 ± 1.5	3.268 ± 0.059
D	3.15 ± 0.25	0.124 ± 0.010
E	38.10 max	1.500 max
F	56.0 max	2.205 max
G	160.0 ± 10.0	6.299 ± 0.394
H	5.0 ± 0.1	0.197 ± 0.004
J	76.2 ± 0.1	3.000 ± 0.004
K	103.3 ± 2.5	4.067 ± 0.098
L	90.8 ± 2.5	3.575 ± 0.098
M	68.3 ± 2.5	2.689 ± 0.098
N	6.35	0.250

Inch dimensions have been derived from millimetres.

Outline Notes

1. The mounting flange is the connection for the cathode, cathode heater return and reservoir heater return.
2. A minimum clearance of 38.0mm (1.496 inches) must be allowed below the mounting flange.
3. The recommended mounting hole is 58.0mm (2.283 inches) diameter.
4. Grid connections fitted with 8–32 UNC screws.

Whilst EEV has taken care to ensure the accuracy of the information contained herein it accepts no responsibility for the consequences of any use thereof and also reserves the right to change the specification of goods without notice. EEV accepts no liability beyond that set out in its standard conditions of sale in respect of infringement of third party patents arising from the use of tubes or other devices in accordance with information contained herein.



DEUTERIUM FILLED TWO-GAP METAL/CERAMIC THYRATRON

The data to be read in conjunction with the Hydrogen Thyatron Preamble.

ABRIDGED DATA

Deuterium-filled two-gap thyatron with metal/ceramic envelope, suitable for switching high peak and average power at high pulse repetition rates. A reservoir operating from the cathode heater supply is incorporated.

Peak forward anode voltage (see note 5)	70	kV max
Peak anode current (see note 7)	10 000	A max
Average anode current	10	A max
Anode heating factor	300×10^9	V.A.p.p.s. max
Peak output power	350	MW max
Operating frequency (see note 15)	20	kHz max

GENERAL

Electrical

Cathode		impregnated tungsten
Cathode heater voltage (see note 1)	$6.3 \pm 7.5\%$	V
Cathode heater current	90	A
Reservoir heater voltage (see notes 1 and 2)	$6.3 \pm 7.5\%$	V
Reservoir heater current	8.0	A
Tube heating time (minimum)	10	min
Anode to gradient grid capacitance	45	pF
Gradient grid to grid 2 capacitance	45	pF

Mechanical

Seated height	320 mm (12.600 inches)	max
Clearance required below mounting flange	75 mm (2.953 inches)	min
Overall diameter	152.4 mm (6.000 inches)	nom
Net weight	6.6 kg (14.5 pounds)	approx
Mounting position		see note 3
Tube connections		see outline

Cooling

The tube may be cooled by forced-air or liquid immersion, depending on operating conditions, to maintain the metal/ceramic envelope below the maximum rated temperature.

In addition to 600 W of heater power, the tube dissipates from 100 W per ampere average anode current, rising to 300 W/A at the highest rates of rise and fall of anode current.

The cathode end of the tube must be cooled whenever heater voltages are applied.

Envelope temperature:

grid 1, grid 2, gradient grid and anode	250	°C max
cathode flange and end cover	150	°C max

PULSE MODULATOR SERVICE

MAXIMUM AND MINIMUM RATINGS (Absolute values)

	Min	Max	
Anode			
Peak forward anode voltage (see notes 4 and 5)	—	70	kV
Peak inverse anode voltage (see notes 5 and 6)	—	70	kV
Peak anode current (see note 7)	—	10 000	A
Average anode current	—	10	A
R.M.S. anode current	—	275	A
Rate of rise of anode current (see note 8)	—	10	kA/ μ s
Anode heating factor	—	300×10^9	V.A.p.p.s.

Grid 2

Unloaded grid 2 drive pulse voltage (see note 9)	600	2000	V
Grid 2 pulse duration	1.0	—	μ s
Rate of rise of grid 2 pulse (see notes 8 and 10)	4.0	—	kV/ μ s
Impedance of grid 2 drive circuit (see note 11)	50	250	Ω
D.C. resistance of grid 2 drive circuit	—	500	Ω
Grid 2 negative bias supply voltage	0	120	V

MAXIMUM AND MINIMUM RATINGS – Continued

	Min	Max	
Grid 1 – D.C. primed (see note 12)			
D.C. grid 1 priming current	0.2	2.0	A
D.C. grid 1 voltage drop	15	30	V

Grid 1 – Pulsed (see note 13)

Unloaded grid 1 drive pulse voltage	300	1000	V
Grid 1 pulse duration	2.0	—	μ s
Rate of rise of grid 1 pulse	1.0	—	kV/ μ s
Peak grid 1 drive current	0.5	2.0	A

Cathode

Heater voltage	$6.3 \pm 7\frac{1}{2}\%$		V
Heating time	10	—	min

Reservoir

Heater voltage	$6.3 \pm 7\frac{1}{2}\%$		V
Heating time	10	—	min

Environmental

Ambient temperature	–40	+90	$^{\circ}$ C
-------------------------------	-----	-----	--------------

CHARACTERISTICS

	Min	Typical	Max	
Critical d.c. anode voltage for conduction	—	0.1	2.0	kV
Anode delay time	—	200	450	ns
Anode delay time drift (see note 14)	—	15	25	ns
Time jitter	—	10	15	ns
Recovery time (see note 16)	—	25	—	μ s
Cathode heater current (at 6.3 V)	80	90	100	A
Reservoir heater current (at 6.3 V)	6.0	7.0	8.0	A

NOTES

1. The reservoir heater can be supplied either from a transformer common to the cathode heater supply or a separate transformer. If a single transformer is used, the reservoir lead must be connected to the mounting flange and the reservoir heater circuit decoupled with a suitable capacitor.

The cathode connection to the load must be adequate to prevent pulse voltages appearing in the heater circuits. At high rates of rise of anode current, the cathode potential may rise significantly at the beginning of the pulse, depending on the cathode lead inductance. The heater transformers must have sufficient insulation to withstand this voltage.

2. The reservoir system of the CX1536 contains a barretter and variations of the reservoir supply voltage within the limits given will not significantly alter the gas pressure.
3. The tube may be mounted in any position provided that the cathode end is lower than the anode.
4. The maximum permissible peak forward voltage for instantaneous starting is 40 kV and there must be no overshoot.
5. For operation at 70 kV, the tube must be liquid immersed. When operated in air, the maximum peak forward or inverse anode voltage must be limited to 50 kV.
6. The peak inverse voltage including spike must not exceed 20 kV for the first 25 μ s after the anode pulse.
7. For pulse durations up to 3 microseconds. For greater pulse durations the peak current must not exceed:—

$$10\,000 \left[\frac{3}{t_p} \right]^{\frac{1}{2}}$$

where t_p is in microseconds.

8. This rate of rise refers to that part of the leading edge of the pulse between 25% and 75% of the pulse amplitude.
9. Measured with respect to cathode.
10. A lower rate of rise may be used, but this may result in the anode delay time, delay time drift and jitter exceeding the limits quoted.
11. During both the drive pulse period and during recovery when the current flow is reversed.
12. This method of operation limits the transient voltages, which appear at the grids during the rise time of the anode current pulse, to less than 1 kV. It is recommended for applications requiring short rise times or high peak currents.

13. Alternatively, grid 1 may be driven from the grid 2 pulse drive through a $100\ \Omega$ resistance in series with $0.01\ \mu\text{F}$; a $500\ \Omega$ resistor should be connected between grid 1 and cathode.
14. Measured between the fifth minute after the application of h.t. and any subsequent time.
15. The CX1536 has a short recovery time for a tube of its size. For peak forward anode voltages below $40\ \text{kV}$, the tube may be operated as a single gap device without the resistive divider shown below and with the gradient grid connected to the cathode through a resistor. A $12\ \text{W}$ wire wound resistor in the range 5 to $20\ \Omega$ is suitable. Under these conditions, the gradient grid acts as a screen for the control grid against high rates of rise of anode voltage.
16. Measured after a current pulse of $1000\ \text{A}$, with a grid 2 bias voltage of $-100\ \text{V}$, a recovery impedance of $500\ \Omega$ and a $1.0\ \text{kV}$ anode probe.

X-RAY WARNING

X-rays are emitted by this device. The metal envelope of the CX1536 provides limited protection but further shielding may be required.

GRADIENT GRID CONNECTIONS

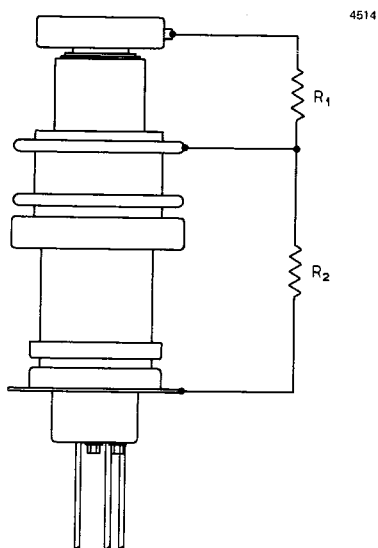

Recommended Values

$$R_1 = R_2 = 10 \text{ to } 20\text{M}\Omega$$

OUTLINE

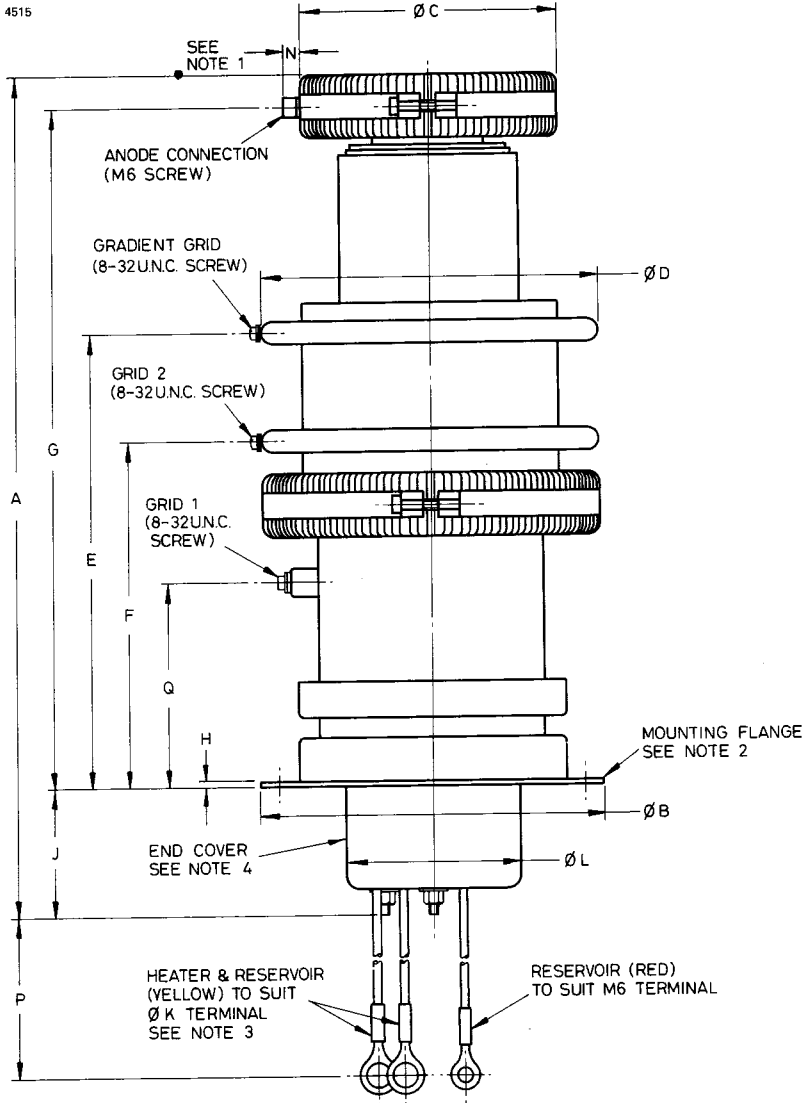

Whilst EEV has taken care to ensure the accuracy of the information contained herein it accepts no responsibility for the consequences of any use thereof and also reserves the right to change the specification of goods without notice. EEV accepts no liability beyond that set out in its standard conditions of sale in respect of infringement of third party patents arising from the use of tubes or other devices in accordance with information contained herein.

Enlarged Detail of Mounting Flange

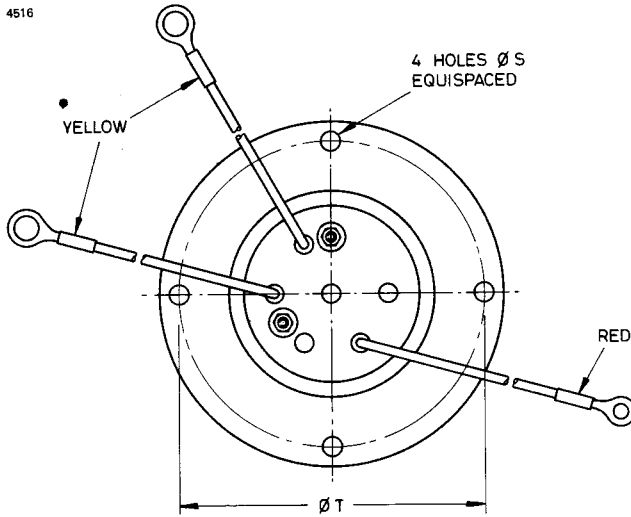

Outline Dimensions (All dimensions without limits are nominal)

Ref	Millimetres	Inches	Ref	Millimetres	Inches
A	375.0 max	14.764 max	J	60.00 max	2.362 max
B	152.4	6.000	K	9.50	0.374
C	114.3	4.500	L	78.00 max	3.071 max
D	150.0	5.906	N	15.00 max	0.591 max
E	200.0	7.874	P	245.0 min	9.646 min
F	152.0	5.984	Q	90.00	3.543
G	300.0	11.811	S	8.00	0.315
H	3.15	0.124	T	135.7	5.343

Inch dimensions have been derived from millimetres.

Outline Notes

1. This dimension also applies to the clamping screws and lugs.
2. The mounting flange is the connection for the cathode and cathode heater return.
3. These two leads must be connected in parallel to the same terminals of the heater transformer.
4. The end cover is at heater potential and must not be grounded.



HYDROGEN THYRATRON

Service Type CV372

The data to be read in conjunction with the Hydrogen Thyatron Preamble.

ABRIDGED DATA

Hydrogen-filled triode thyatron, positive grid, for pulse operation. A hydrogen reservoir is incorporated.

Peak forward anode voltage	3.0	kV max
Peak anode current	40	A max
Average anode current	50	mA max
Anode heating factor	0.36×10^9	V.A.p.p.s. max
Peak output power	60	kW max

GENERAL

Electrical

Cathode (connected internally to one end of heater)	oxide coated
Heater voltage	6.3 ^{+ 5%} - 10% V
Heater current	2.7 A
Tube heating time (minimum)	2.0 min

Mechanical

Overall length	5.000 inches (127.0mm) max
Overall diameter	1.532 inches (38.9mm) max
Net weight	2 ounces (60g) approx
Mounting position (see note 1)	any
Base	medium UX4
Top cap	B.S.448-CT2

Cooling	natural
-------------------	---------

PULSE MODULATOR SERVICE

MAXIMUM AND MINIMUM RATINGS (Absolute values)

	Min	Max	
Anode			
Peak forward anode voltage (see note 2)	—	3.0	kV
Peak inverse anode voltage (see note 3)	—	3.0	kV
Peak anode current	—	40	A
Average anode current	—	50	mA
Rate of rise of anode current (see note 4)	—	750	A/ μ s
Anode heating factor	—	0.36×10^9	V.A.p.p.s.
Grid			
Unloaded grid drive pulse voltage (see note 5)	175	—	V
Grid pulse duration	2.0	—	μ s
Rate of rise of grid pulse (see note 4)	160	—	V/ μ s
Peak inverse grid voltage	—	200	V
Loaded grid bias voltage	0	-120	V
Forward impedance of grid drive circuit	—	1500	Ω
Cathode			
Heater voltage	6.3	$+5\%$ -10%	V
Tube heating time	2.0	—	min
Environmental			
Ambient temperature	-50	+90	$^{\circ}$ C
Altitude	—	10 000	ft
	—	3	km

CHARACTERISTICS

	Min	Typical	Max	
Critical d.c. anode voltage for conduction (see note 6)	—	200	800	V
Anode delay time (see notes 6 and 7)	—	0.3	0.6	μ s
Anode delay time drift (see notes 6 and 8)	—	0.05	0.15	μ s
Time jitter (see notes 6 and 9)	—	3.0	20	ns
Recovery time	—	see note 10 and curves		
Heater current (at 6.3V)	2.35	2.7	3.0	A

NOTES

1. The tube should preferably be clamped by the base only. Any clamps used on the bulb must not extend beyond 2 inches (50mm approx) above the top of the base and should be made from material of low thermal conductivity.
2. For instantaneous starting applications the maximum permissible peak forward voltage is 3.0kV. This must not be reached in less than 0.04 second and there must be no overshoot.
3. In pulsed operation the peak inverse anode voltage, exclusive of a spike of 0.05 microsecond duration, must not exceed 1.5kV during the first 25 microseconds after the pulse.
4. This rate of rise refers to that part of the leading edge of the pulse between 25% and 75% of the pulse amplitude.
5. Measured with respect to cathode potential.
6. The typical figures are obtained on test using conditions of minimum grid drive. Improved performance can be expected by increasing the grid drive.
7. The time interval between a point on the leading edge of the unloaded grid pulse at 25% of the pulse amplitude and the point where anode conduction takes place.
8. Normally taken as the drift in delay time over a 5-minute run at full ratings between the second and seventh minutes of operation.
9. The variation of firing time measured at 50% of current pulse amplitude.
10. The recovery characteristics are controlled on a sampling basis.

MAXIMUM RECOVERY CHARACTERISTICS

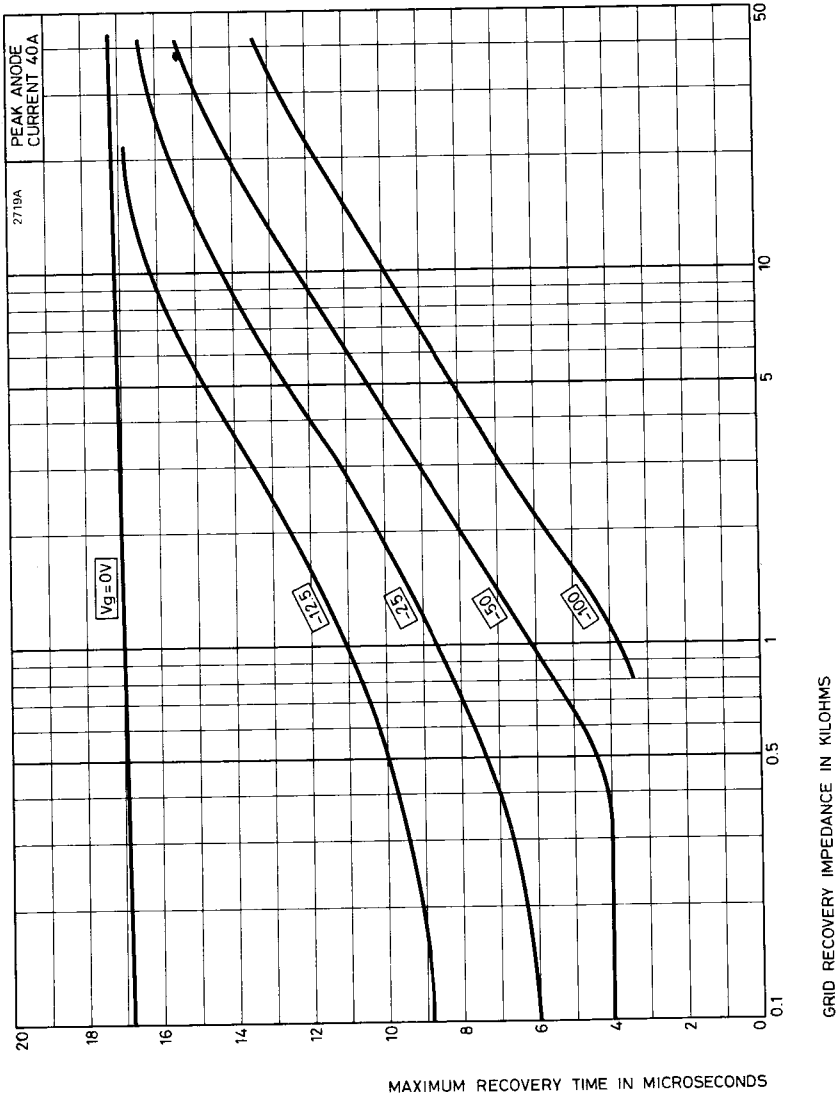

OUTLINE (All dimensions without limits are nominal)

2720A

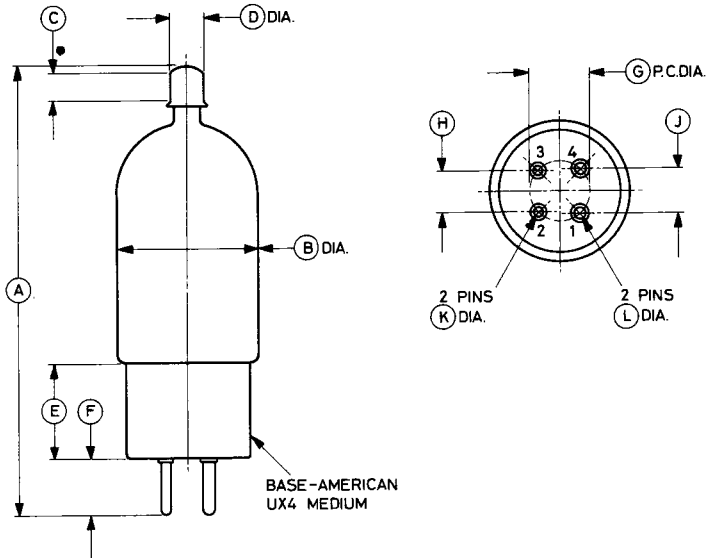

Ref	Inches	Millimetres
A	4.750 ± 0.250	120.7 ± 6.4
B	1.535 max	39.00 max
C	0.268 min	6.81 min
D	0.359 ± 0.003	9.119 ± 0.076
E	1.087 max	27.61 max
F	0.629 max	15.98 max
G	0.640	16.26
H	0.437	11.10
J	0.468	11.89
K	0.125 ± 0.005	3.18 ± 0.13
L	0.156 ± 0.003	3.962 ± 0.076

Pin	Element
1	Heater
2	Cathode
3	Grid
4	Heater, cathode
Top cap	Anode

Millimetre dimensions have been derived from inches except dimension B.

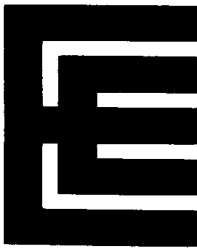

HYDROGEN THYRATRON

The data to be read in conjunction with the Hydrogen Thyatron Preamble.

ABRIDGED DATA

Hydrogen-filled triode thyatron for use as an inverse or charging diode in pulse modulators. By virtue of its comparatively long recovery time it is suitable for operation in high power modulators of long pulse length. A hydrogen reservoir is incorporated.

Peak inverse anode voltage	25	kV max
Peak anode current	500	A max
Average anode current	1.25	A max

GENERAL

Electrical

Cathode (connected internally to mid-point of heater)	oxide coated
Heater voltage	6.3 ± 5% V
Heater current	21.5 A
Tube heating time (minimum)	5.0 min
Inter-electrode capacitances (approximate):	
anode to grid (cathode not connected)	5.0 pF
anode to cathode (grid not connected)	25 pF

Mechanical

Overall length	12.500 inches (317.5mm) max
Overall diameter	3.312 inches (84.12mm) max
Net weight	1½ pounds (0.7kg) approx
Mounting position (see note 1)	any
Base	pin spacing as B5F; metal shell with micalex insert
Top cap (see note 2)	B.S.448-CT3

Cooling	natural
--------------------------	---------

MAXIMUM AND MINIMUM RATINGS (Absolute values)

	Min	Max	
Anode			
Peak inverse anode voltage	—	25	kV
Peak anode current	—	500	A
Average anode current	—	1.25	A
Rate of rise of anode current (see note 3)	—	2500	A/ μ s

Grid			
Unloaded grid drive pulse voltage (see note 4)	300	1000	V
Grid pulse duration	1.0	—	μ s
Rate of rise of grid pulse (see note 3)	1.0	—	kV/ μ s
Loaded grid bias voltage (see note 5)	0	−120	V
Peak grid drive current	—	1.0	A
Average grid drive current (see note 6)	1.0	10	mA

Cathode			
Heater voltage	6.3 \pm 5%	—	V
Tube heating time	5.0	—	min

Environmental			
Ambient temperature	−55	+90	$^{\circ}$ C
Altitude	—	10 000	ft
	—	3	km

Maximum Simultaneous Inverse Diode Ratings

Peak anode current	—	500	A
Anode pulse duration	—	100	μ s

CHARACTERISTICS

	Min	Max	
Critical d.c. anode voltage for conduction	—	100	V
Anode delay time (see notes 7 and 8)	—	0.2	μ s
Recovery time (see note 9)	—	50	μ s
Heater current (at 6.3V)	18	25	A

NOTES

1. Clamping is permissible by the base only.
2. A large area anode connector MA360 is recommended.
3. This rate of rise refers to that part of the leading edge of the pulse between 25% and 75% of the pulse amplitude.
4. Measured with respect to cathode potential.
5. For inverse diode applications, the tube is normally operated without grid bias. The use of negative grid bias causes a decrease in recovery time.
6. These conditions apply to a continuous grid discharge.
7. The typical figures are obtained on test using conditions of minimum grid drive. Improved performance can be expected by increasing the grid drive.
8. The time interval between a point on the leading edge of the unloaded grid pulse at 25% of the pulse amplitude and the point where anode conduction takes place.
9. The time specified is the recovery time after a 100A pulse with zero potential on the grid. The recovery time increases with increased anode current.

OUTLINE (All dimensions without limits are nominal)

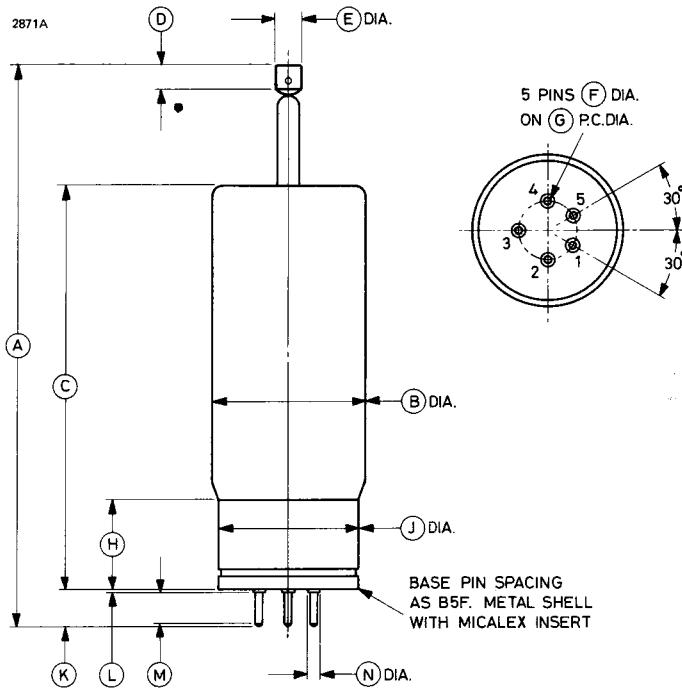

Ref	Inches	Millimetres
A	12.000 ± 0.500	304.8 ± 12.7
B	3.312 max	84.12 max
C	8.500 ± 0.500	215.9 ± 12.7
D	0.500 min	12.70 min
E	0.566 ± 0.007	14.38 ± 0.18
F	0.187 ± 0.003	4.750 ± 0.076
G	1.250	31.75
H	1.937	49.20
J	3.062 ± 0.062	77.77 ± 1.57
K	0.770 max	19.56 max
L	0.073 max	1.85 max
M	0.575 min	14.60 min
N	0.260 max	6.60 max

Pin	Element
1	Heater
2	Cathode
3	Grid
4	No connection
5	Heater
Top cap	Anode

Millimetre dimensions have been derived from inches.

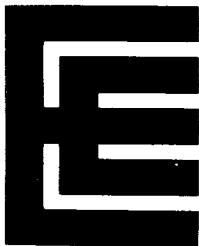

HYDROGEN THYRATRON

The data to be read in conjunction with the Hydrogen Thyatron Preamble.

ABRIDGED DATA

Hydrogen-filled triode thyatron, positive grid, for pulse operation. A hydrogen reservoir is incorporated. The tube is ruggedized to meet the requirements of airborne applications. Environmental tests applied to the tube comply with those of the CV6022 specification and include linear acceleration at 12g, and vibration at $\frac{1}{4}g$ minimum acceleration and 150Hz frequency or at the frequency of maximum resonance in the range between 10 and 150Hz.

Peak forward anode voltage	16	kV max
Peak anode current	325	A max
Average anode current	225	mA max
Anode heating factor	3.9×10^9	V.A.p.p.s. max
Peak output power	2.0	MW max

GENERAL

Electrical

Cathode (connected internally to one end of heater)	oxide coated
Heater voltage	$6.3 \pm 7\%$ V
Heater current	10.6 A
Tube heating time (minimum)	3.0 min

Mechanical

Overall length	6.250 inches (158.8mm) max
Overall diameter	2.563 inches (65.1mm) max
Net weight	12 ounces (350g) approx
Mounting position	any
Clamping	see note 1
Base	B.S.448-B7D (JEDEC A7-17)
Top cap	B.S.448-CT3

Cooling	natural
-------------------	---------

PULSE MODULATOR SERVICE

MAXIMUM AND MINIMUM RATINGS (Absolute values)

	Min	Max	
Anode			
Peak forward anode voltage (see note 2)	—	16	kV
Peak inverse anode voltage (see note 3)	—	16	kV
Peak anode current	—	325	A
Average anode current	—	225	mA
Rate of rise of anode current (see note 4)	—	1500	A/ μ s
Anode heating factor	—	3.9×10^9	V.A.p.p.s.

Grid

Unloaded grid drive pulse voltage (see note 5)	200	—	V
Grid pulse duration	2.0	—	μ s
Rate of rise of grid pulse (see note 4)	180	—	V/ μ s
Peak inverse grid voltage	—	200	V
Loaded grid bias voltage	0	-120	V
Forward impedance of grid drive circuit	50	500	Ω

Cathode

Heater voltage	$6.3 \pm 7\frac{1}{2}\%$	—	V
Tube heating time	3.0	—	min

Environmental

Environmental performance	—	—	see note 6
Ambient temperature	-50	+90	$^{\circ}$ C
Altitude	—	10 000	ft
	—	3	km

CHARACTERISTICS

	Min	Typical	Max	
Critical d.c. anode voltage for conduction (see note 7)	—	0.3	1.0	kV
Anode delay time (see notes 7 and 8)	—	0.3	0.65	μ s
Anode delay time drift (see notes 7 and 9)	—	0.05	0.1	μ s
Time jitter (see notes 7 and 10)	—	3.0	5.0	ns
Recovery time	—	—	—	see note 11 and curves
Heater current (at 6.3V)	9.6	10.6	11.6	A
Additional tests	—	—	—	see note 12

NOTES

1. The tube should preferably be clamped by the base only. Any clamps used on the bulb must not extend beyond $4\frac{1}{4}$ inches (108mm) above the top of the base and should be made from material of low thermal conductivity.
2. This is the maximum forward hold-off voltage imposed on the thyatron in a pulse modulator circuit. Tubes are tested at 18kV peak forward anode voltage, with the charging reactor inductance and pulse forming network capacitance resonant at 1000p.p.s. For instantaneous starting applications the maximum permissible peak forward voltage is 13.5kV; this must not be reached in less than 0.04 second and there must be no overshoot.
3. In pulsed operation the peak inverse anode voltage, exclusive of a spike of 0.05 microsecond duration, must not exceed 5.0kV during the first 25 microseconds after the pulse.
4. This rate of rise refers to that part of the leading edge of the pulse between 25% and 75% of the pulse amplitude.
5. Measured with respect to cathode potential.
6. All tubes are subjected to an acceleration of 10g at 50Hz before testing. In addition, samples are tested under the following conditions:
 - (a) **Linear Acceleration** 12g (min) is applied and maintained for 1 minute at right angles to and in each direction along the major axis of the tube. A heater voltage of 6.3V is applied during the test.
 - (b) **Resonance Search** Vibration is applied in two mutually perpendicular directions, one of which is parallel to the longitudinal axis of the tube. The frequency is swept at a rate not exceeding one octave per minute between 10 and 150Hz, with accelerations of $\frac{1}{4}$ g (min). All resonances detectable visually or electrically are noted for information and also for use in test (c). Normal operating voltages are applied during the test.
 - (c) **Vibration Fatigue** Each tube is subjected to vibration for two periods of ten hours. In one period the direction of vibration is parallel to the longitudinal axis of the tube, and in the other the direction is perpendicular to the longitudinal axis of the tube.

The acceleration is $\frac{1}{4}g$ and the frequency is that of the strongest resonance detected during the resonance search. If no resonances were detected in the search, then a frequency of 150Hz is used. A heater voltage of 6.3V is applied during the test.

•
Tubes must pass operational tests after the above procedure has been completed.

7. The typical figures are obtained on test using conditions of minimum grid drive. Improved performance can be expected by increasing the grid drive.
8. The time interval between a point on the leading edge of the unloaded grid pulse at 25% of the pulse amplitude and the point where anode conduction takes place.
9. Normally taken as the drift in delay time over a 5-minute run at full ratings between the second and seventh minutes of operation.
10. The variation of firing time measured at 50% of current pulse amplitude.
11. The recovery characteristics are controlled on a sampling basis.
12. In addition to operational testing at pulse repetition rates of 800 and 1000p.p.s. on all tubes, an additional test at 2500p.p.s., 12.5kV, is performed on a sampling basis.

X-RAY WARNING

X-rays are emitted by the FX2501 from the region of the anode, but the radiation is usually reduced to a safe level by the metal panels of the equipment in which the tube operates.

MAXIMUM RECOVERY CHARACTERISTICS



OUTLINE (All dimensions without limits are nominal)

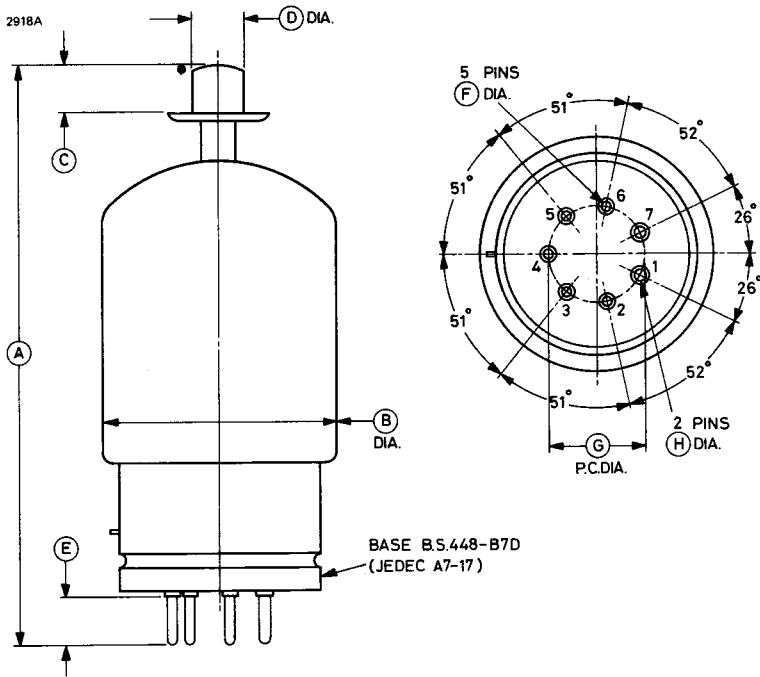

Ref	Inches	Millimetres
A	6.250	158.8
B	2.563 max	65.10 max
C	0.375 min	9.53 min
D	0.566 ± 0.005	14.38 ± 0.13
E	0.500	12.70
F	0.125 ± 0.003	3.175 ± 0.076
G	1.000	25.40
H	0.156 ± 0.003	3.962 ± 0.076

Pin	Element
1	Heater
2	Grid 1
3	Cathode
4	No connection
5	Cathode
6	Grid 1
7	Heater
Top cap	Anode

Millimetre dimensions have been derived from inches.



DEUTERIUM THYRATRON

The data to be read in conjunction with the Hydrogen Thyatron Preamble.

ABRIDGED DATA

Deuterium-filled triode thyatron for use as an inverse or charging diode in pulse modulators. By virtue of its comparatively long recovery time it is suitable for operation in high power modulators of long pulse length. A reservoir is incorporated.

Peak inverse anode voltage	33	kV max
Peak anode current	500	A max
Average anode current	1.25	A max

GENERAL

Electrical

Cathode (connected internally to mid-point of heater)	oxide coated
Heater voltage	6.3 ± 5% V
Heater current	21.5 A
Tube heating time (minimum)	5.0 min
Inter-electrode capacitances (approximate):	
anode to grid (cathode not connected)	5.0 pF
anode to cathode (grid not connected)	25 pF

Mechanical

Overall length	13.500 inches (342.9mm) max
Overall diameter	3.312 inches (84.12mm) max
Net weight	1½ pounds (0.7kg) approx
Mounting position (see note 1)	any
Base	pin spacing as B5F; metal shell with micalex insert
Top cap (see note 2)	B.S.448-CT3 (see outline)

Cooling see note 3

MAXIMUM AND MINIMUM RATINGS (Absolute values)

	Min	Max	
Anode			
Peak inverse anode voltage	—	33	kV
Peak anode current	—	500	A
Average anode current	—	1.25	A
Rate of rise of anode current (see note 4)	—	2500	A/ μ s

Grid

Unloaded grid drive pulse voltage (see note 5)	300	1000	V
Grid pulse duration	1.0	—	μ s
Rate of rise of grid pulse (see note 4)	1.0	—	kV/ μ s
Loaded grid bias voltage (see note 6)	0	−120	V
Peak grid drive current	—	1.0	A
Average grid drive current (see note 7)	1.0	10	mA

Cathode

Heater voltage	6.3 ± 5%	—	V
Heating time	5.0	—	min

Environmental

Ambient temperature	−55	+90	°C
Altitude	—	10 000	ft
	—	3	km

Maximum Simultaneous Inverse Diode Ratings

Peak anode current	—	500	A
Anode pulse duration	—	100	μ s

CHARACTERISTICS

	Min	Max	
Critical d.c. anode voltage for conduction	—	100	V
Anode delay time (see notes 8 and 9)	—	0.2	μ s
Recovery time (see note 10)	—	70	μ s
Heater current (at 6.3V)	18	25	A

NOTES

1. Clamping is permissible by the base only.
2. A separate anode adaptor is supplied with the tube. When fitting the adaptor, it should be slid over the anode pin until it seats down; it should then be raised by 1mm or until the top of the pin is level with the top of the adaptor insert, whichever gives the larger clearance from the glass, and clamped in position.
3. For anode voltages exceeding 25kV the anode must be cooled with forced air at 0.5 to 2ft³/min (0.014 to 0.057m³/min). The air hose should be connected to the anode adaptor so that the air flow is directed onto the anode seal.
4. This rate of rise refers to that part of the leading edge of the pulse between 25% and 75% of the pulse amplitude.
5. Measured with respect to cathode potential.
6. For inverse diode applications, the tube is normally operated without grid bias. The use of negative grid bias causes a decrease in recovery time.
7. The conditions apply to a continuous grid discharge from a d.c. supply of 100V minimum with a current limiting resistor in series with the grid.
8. The typical figures are obtained on test using conditions of minimum grid drive. Improved performance can be expected by increasing the grid drive.
9. The time interval between a point on the leading edge of the unloaded grid pulse at 25% of the pulse amplitude and the point where anode conduction takes place.
10. The time specified is the recovery time after a 100A pulse with zero potential on the grid. The recovery time increases with increased anode current.

OUTLINE (All dimensions without limits are nominal)

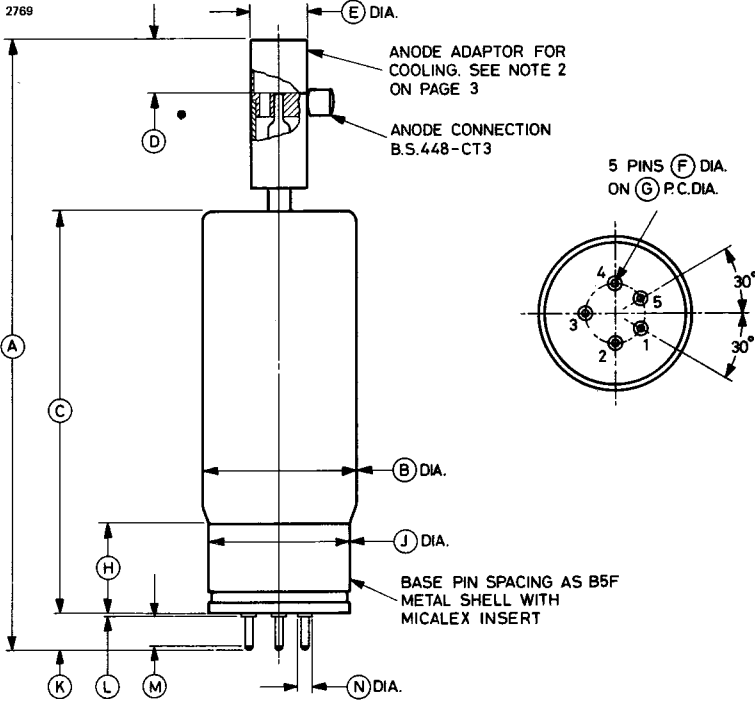

Ref	Inches	Millimetres	Pin	Element
A	13.000 ± 0.500	330.2 ± 12.7	1	Heater
B	3.312 max	84.12 max	2	Cathode
C	8.500 ± 0.500	215.9 ± 12.7	3	Grid
D	1.000	25.40	4	No connection
E	1.250 ± 0.007	31.75 ± 0.18	5	Heater
F	0.187 ± 0.003	4.750 ± 0.076	Top cap	Anode
G	1.250	31.75		
H	1.937	49.20		
J	3.062 ± 0.062	77.77 ± 1.57		
K	0.770 max	19.56 max		
L	0.073 max	1.85 max		
M	0.575 min	14.60 min		
N	0.260 max	6.60 max		

Millimetre dimensions have been derived from inches.



HYDROGEN THYRATRON

The data to be read in conjunction with the Hydrogen Thyatron Preamble.

ABRIDGED DATA

Hydrogen-filled triode thyatron, positive grid, for pulse operation. A hydrogen reservoir is incorporated. Electrically superior to 4C35A.

Peak forward anode voltage	10	kV max
Peak anode current	100	A max
Average anode current	125	mA max
Anode heating factor	2.8×10^9	V.A.p.p.s. max
Peak output power	0.5	MW max

GENERAL

Electrical

Cathode (connected internally to one end of heater)	oxide coated	
Heater voltage	$6.3^{+5\%}$ -10%	V
Heater current	6.1	A
Tube heating time (minimum)	3.0	min

Mechanical

Overall length	6.875 inches (174.6mm) max
Overall diameter	2.562 inches (65.1mm) max
Net weight	9 ounces (260g) approx
Mounting position (see note 1)	any
Base	B4D, bayonet
Top cap	B.S.448-CT3

Cooling	natural
--------------------------	---------

PULSE MODULATOR SERVICE

MAXIMUM AND MINIMUM RATINGS (Absolute values)

	Min	Max	
Anode			
Peak forward anode voltage (see note 2)	—	10	kV
Peak inverse anode voltage (see note 3)	—	10	kV
Peak anode current	—	100	A
Average anode current	—	125	mA
Rate of rise of anode current (see note 4)	—	1500	A/ μ s
Anode heating factor	—	2.8×10^9	V.A.p.p.s.

Grid

Unloaded grid drive pulse voltage (see note 5)	175	—	V
Grid pulse duration	2.0	—	μ s
Rate of rise of grid pulse (see note 4)	160	—	V/ μ s
Peak inverse grid voltage	—	200	V
Loaded grid bias voltage	0	-120	V
Forward impedance of grid drive circuit	—	1500	Ω

Cathode

Heater voltage	6.3	+5% -10%	V
Tube heating time	3.0	—	min

Environmental

Ambient temperature	-50	+90	$^{\circ}$ C
Altitude	—	10 000	ft
	—	3	km

CHARACTERISTICS

	Min	Typical	Max	
Critical d.c. anode voltage for conduction (see note 6)	—	0.3	1.0	kV
Anode delay time (see notes 6 and 7)	—	0.35	0.6	μ s
Anode delay time drift (see notes 6 and 8)	—	0.03	0.1	μ s
Time jitter (see note 6 and 9)	—	3.0	5.0	ns
Recovery time	—	—	—	see note 10 and curves
Heater current (at 6.3V)	5.5	6.1	6.7	A

NOTES

1. The tube should preferably be clamped by the base only. Any clamps used on the bulb must not extend beyond 2½ inches (63.5mm) above the top of the base and should be made from material of low thermal conductivity.
2. For instantaneous starting applications the maximum permissible peak forward voltage is 8.0kV and there must be no overshoot.
3. In pulsed operation the peak inverse anode voltage, exclusive of a spike of 0.05 microsecond duration, must not exceed 2.5kV during the first 25 microseconds after the pulse.
4. This rate of rise refers to that part of the leading edge of the pulse between 25% and 75% of the pulse amplitude.
5. Measured with respect to cathode potential.
6. The typical figures are obtained on test using conditions of minimum grid drive. Improved performance can be expected by increasing the grid drive.
7. The time interval between a point on the leading edge of the unloaded grid pulse at 25% of the pulse amplitude and the point where anode conduction takes place.
8. Normally taken as the drift in delay time over a 5-minute run at full ratings between the second and seventh minutes of operation.
9. The variation of firing time measured at 50% of current pulse amplitude.
10. The recovery characteristics are controlled on a sampling basis.

MAXIMUM RECOVERY CHARACTERISTICS

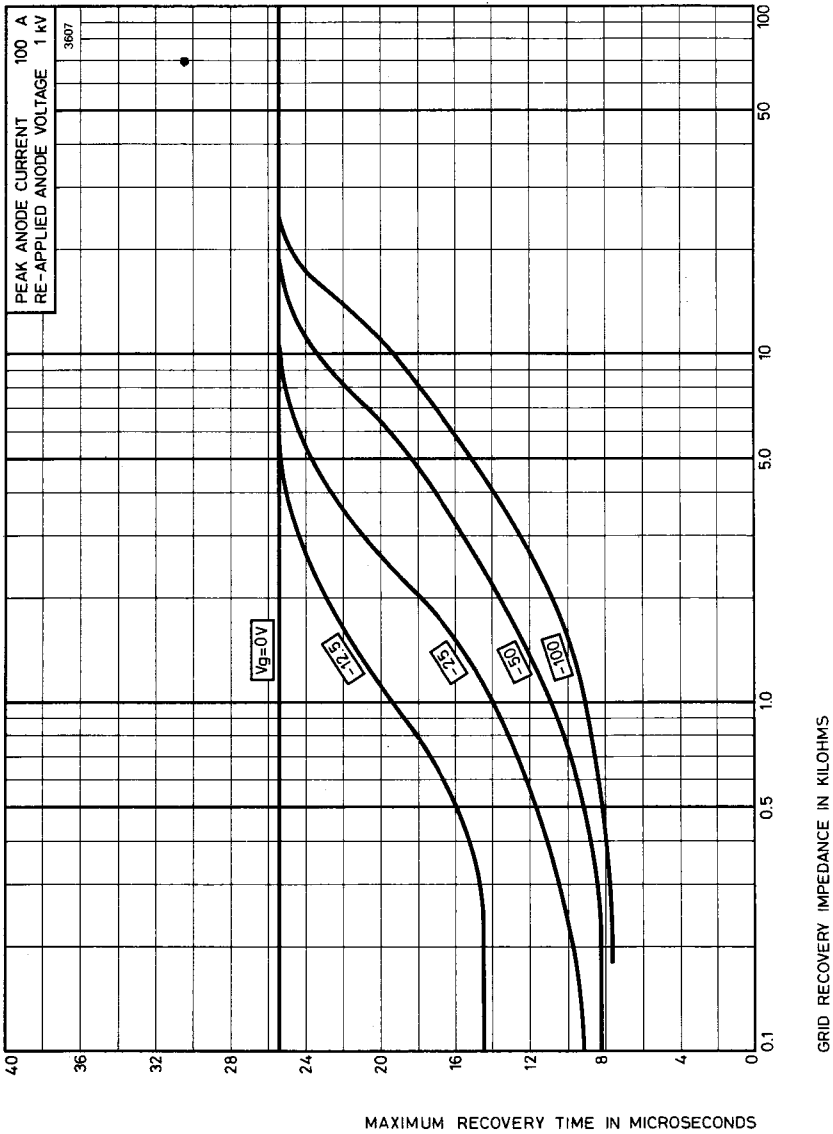

OUTLINE (All dimensions without limits are nominal)

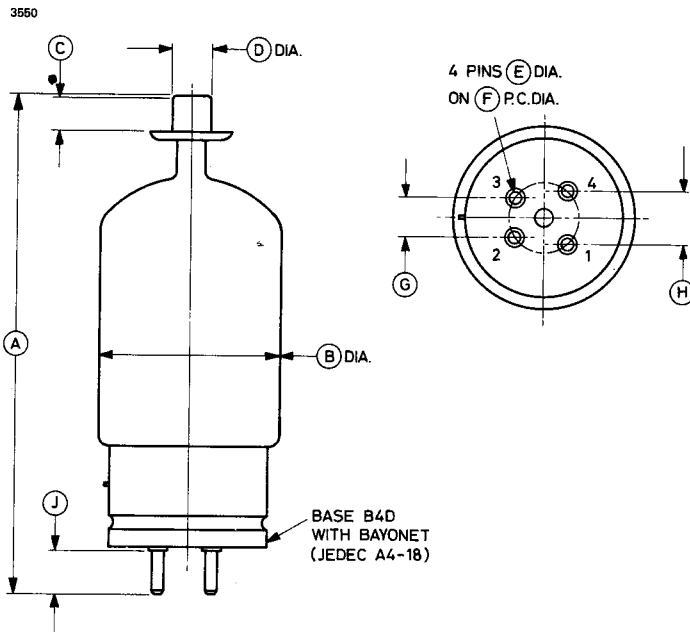

Ref	Inches	Millimetres
A	6.875 max	174.6 max
B	2.563 max	65.10 max
C	0.375 min	9.53 min
D	0.566 ± 0.007	14.38 ± 0.18
E	0.187 ± 0.003	4.750 ± 0.076
F	1.000	25.40
G	0.562	14.27
H	0.750	19.05
J	0.625	15.88

Pin	Element
1	Grid
2	Heater, cathode
3	Heater
4	Cathode
Top cap	Anode

Millimetre dimensions have been derived from inches.



HYDROGEN-FILLED CERAMIC THYRATRON

The data to be read in conjunction with the Hydrogen Thyatron Preamble.

DESCRIPTION

The FX2507/8613 is a rugged hydrogen thyatron designed for use in compact airborne radars, particularly with 250kW X-band magnetrons such as the 7008. It has a ceramic envelope with a B4D base, and is intended to replace glass envelope tubes without equipment modification.

It features low jitter and low anode delay time and is suitable for use at high pulse repetition rates; it can switch peak powers up to 3MW. The tube will operate over an ambient temperature range of -55 to $+130^{\circ}\text{C}$. A hydrogen reservoir is internally connected.

This tube complies with and is tested to MIL-E-1/1590B.

Peak forward anode voltage	16	kV max
Peak inverse anode voltage	16	kV max
Peak anode current	500	A max
Average anode current	500	mA max
Rate of rise of anode current	2000	A/ μs max
Anode heating factor	10×10^9	V.A.p.p.s. max

GENERAL

Electrical

Cathode (connected internally to one end of heater)		oxide coated
Heater voltage	$6.3 \pm 7\frac{1}{2}\%$	V
Heater current	10.6	A
Tube heating time (minimum)	3.0	min

Mechanical

Overall length	6.625 inches (168.3mm) max
Overall diameter	2.375 inches (60.33mm) max
Net weight	1 pound (454g) approx
Mounting position	any
Clamping	see note 1
Base	B4D, bayonet
Top cap	National type 12 or B.S.448-CT3

Cooling natural or forced-air

Where natural cooling is insufficient to maintain the envelope temperatures below the specified rated values, forced-air cooling up to 10ft³/min may be used. The temperature of the anode terminal and the base must not exceed the values specified below.

Anode terminal	250	°C max
Base	220	°C max

PULSE MODULATOR SERVICE

MAXIMUM AND MINIMUM RATINGS (Absolute values)

	Min	Max	
Anode			
Peak forward anode voltage (see note 2)	—	16	kV
Peak inverse anode voltage (see note 3)	—	16	kV
Peak anode current	—	500	A
Average anode current	—	500	mA
Rate of rise of anode current (see note 4)	—	2000	A/μs
Anode heating factor	—	10 x 10 ⁹	V.A.p.p.s.

Grid			
Unloaded grid drive pulse voltage (see note 5)	175	600	V
Grid pulse duration	2.0	—	μs
Rate of rise of grid pulse (see note 4)	180	—	V/μs
Peak inverse grid voltage	—	200	V
Loaded grid bias voltage	0	—200	V
Forward impedance of grid drive circuit	—	500	Ω

MAXIMUM AND MINIMUM RATINGS – Continued

	Min	Max	
Cathode			
Heater voltage	6.3 ± 7½%		V
Tube heating time	3.0	—	min
Environmental			
Environmental performance			see note 6
Ambient temperature	–55	+130	°C
Altitude	—	10 000	ft
	—	3	km

CHARACTERISTICS

	Min	Typical	Max	
Critical d.c. anode voltage				
for conduction (see note 7)	—	0.3	1.0	kV
Anode delay time (see notes				
7 and 8)	—	0.3	0.5	µs
Anode delay time drift (see notes				
7 and 9)	—	0.05	0.1	µs
Time jitter (see notes 7 and 10)	—	3.0	5.0	ns
Recovery time				see note 11 and curves
Heater current (at 6.3V)	9.6	10.6	11.5	A
Additional tests				see note 12

NOTES

1. The tube must only be clamped by the base.
2. This is the maximum forward hold-off voltage imposed on the thyatron in a pulse modulator circuit. Tubes are tested at 18kV peak forward anode voltage, with the charging reactor inductance and pulse forming network capacitance resonant at 1000p.p.s. For instantaneous starting applications the maximum permissible peak forward voltage is 16kV; this must not be reached in less than 0.04 second and there must be no overshoot.

3. In pulsed operation the peak inverse anode voltage, exclusive of a spike of 0.05 microsecond maximum duration, must not exceed 5.0kV during the first 25 microseconds after the pulse.
4. This rate of rise refers to that part of the leading edge of the pulse between 25% and 75% of the pulse amplitude.
5. Measured with respect to cathode potential.
6. To ensure a high standard of ruggedness, all tubes are subjected to the following tests. After each mechanical test all the tubes must then satisfy all electrical tests.
 - (a) Vibration — The tubes are vibrated at 50Hz with acceleration of 10g for one minute in the direction of the cathode axis and then in one direction perpendicular to the cathode axis.
 - (b) Recovery Time — The tubes are tested for recovery at zero grid bias voltage with a maximum limit of 35 μ s.

The tubes are subjected to the following tests on a sampling basis.

- (c) Operation under Vibration — The tubes are vibrated at 10g in each of three planes at a sweep rate of one octave per minute from 20 to 500 to 20Hz, under normal operating conditions.
 - (d) Survival under Vibration and Heater Cycling — The tubes are vibrated at 10g at a sweep rate of one octave per minute from 5 to 500Hz for 70 hours in each plane together with heater cycling of a 10 minute on/off cycle.
 - (e) Long Duration Shock — The tubes are tested at 100g for ten milliseconds with two blows in each plane.
 - (f) High Temperature Test — The tubes are tested at a base temperature of 220°C and an anode temperature of 250°C under normal operating conditions for 5 hours. This implies an ambient temperature of 130°C.
 - (g) Standby-Life — The tubes are run with 6.3V heater voltage applied for 500 hours.
7. The typical figures are obtained on test using conditions of minimum grid drive. Improved performance can be expected by increasing the grid drive.

8. The time interval between a point on the leading edge of the unloaded grid pulse at 25% of the pulse amplitude and the point where anode conduction takes place.
9. Normally taken as the drift in delay time over a 5-minute run at full ratings between the second and seventh minutes of operation.
10. The variation of firing time measured at 50% of current pulse amplitude.
11. The recovery characteristics are controlled on a sampling basis.
12. In addition to operational testing at pulse repetition rates of 800 and 1000p.p.s. on all tubes, an additional test at 2500p.p.s., 14kV, is performed on a sampling basis.

MAXIMUM RECOVERY CHARACTERISTICS

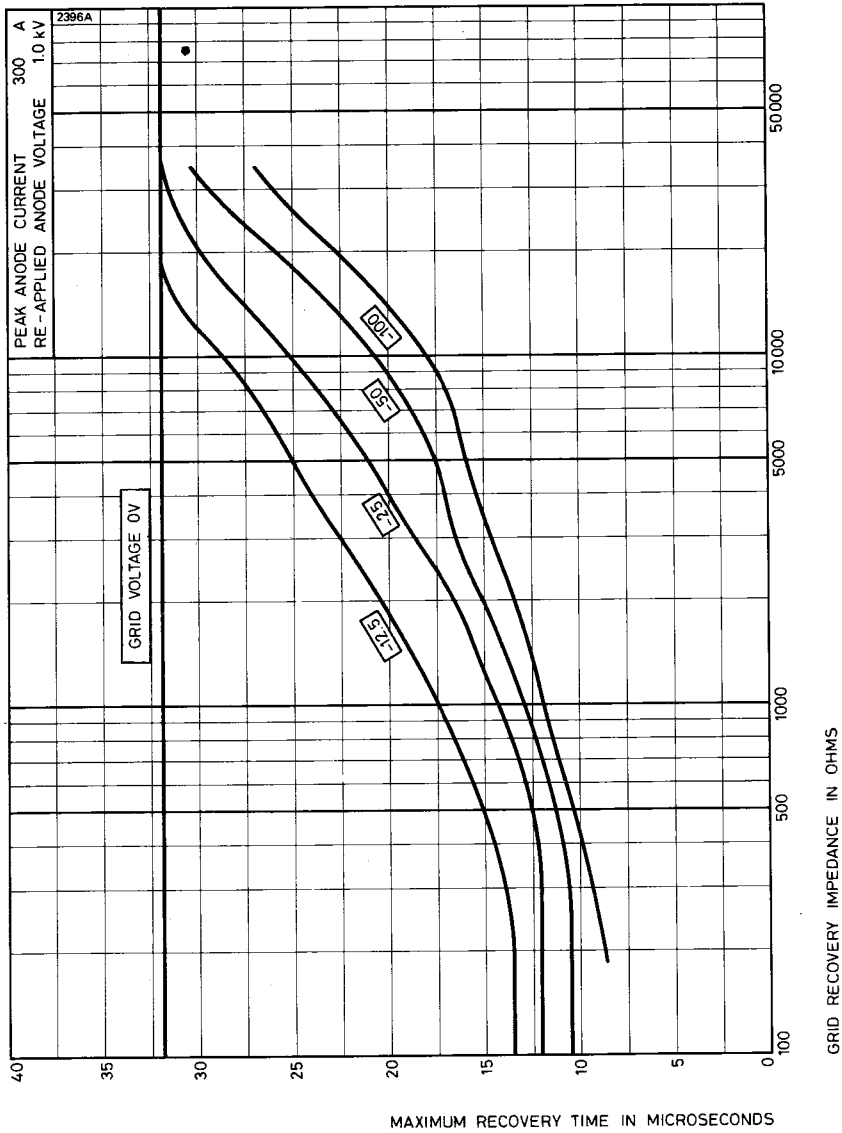

OUTLINE

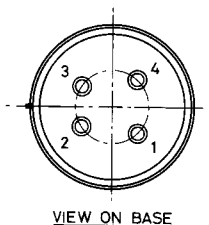
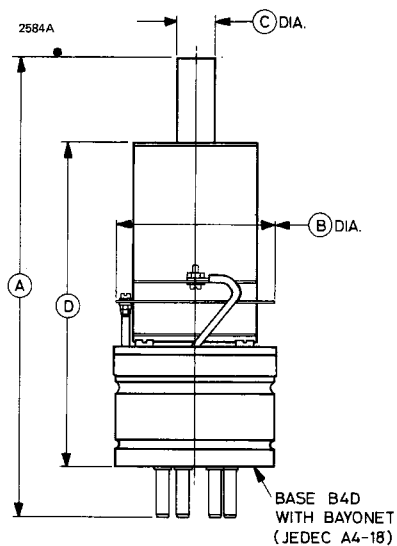

Connections

Pin	Element
1	Grid
2	Heaters & cathode
3	Heaters
4	Cathode
Top cap	Anode

Ref	Inches	Millimetres
A	6.375 ± 0.250	161.9 ± 6.4
B	2.250 ± 0.125	57.15 ± 3.18
C	0.566 ± 0.007	14.38 ± 0.18
D	4.875 nom	123.8 nom

Millimetre dimensions have been derived from inches.

Outline Notes

1. The two flanges are electrically and mechanically connected to the grid.
2. The cathode is electrically isolated from the base shell.



HYDROGEN THYRATRON

The data to be read in conjunction with the Hydrogen Thyatron Preamble.

ABRIDGED DATA

Ruggedized hydrogen-filled triode thyatron, positive grid, for pulse operation especially in airborne radar systems. A hydrogen reservoir is incorporated.

Peak forward anode voltage	10	kV max
Peak anode current	100	A max
Average anode current	100	mA max
Anode heating factor	2.8×10^9	V.A.p.s. max
Peak output power	0.5	MW max

GENERAL

Electrical

Cathode (connected internally to one end of the heater)	oxide coated
Heater voltage	$6.3^{+5\%}_{-10\%}$ V
Heater current	6.1 A
Tube heating time (minimum)	3.0 min

Mechanical

Overall length	5.000 inches (127.0mm) max
Overall diameter	1.535 inches (39.0mm) max
Net weight	4 ounces (113g) approx
Mounting position (see note 1)	any
Base	adapted JEDEC A4-89
Top cap	B.S.448-CT2

Cooling	natural
-------------------	---------

PULSE MODULATOR SERVICE

MAXIMUM AND MINIMUM RATINGS (Absolute values)

	Min	Max	
Anode			
Peak forward anode voltage (see note 2)	—	10	kV
Peak inverse anode voltage (see note 3)	—	10	kV
Peak anode current	—	100	A
Average anode current	—	100	mA
Rate of rise of anode current (see note 4)	—	1500	A/ μ s
Anode heating factor	—	2.8×10^9	V.A.p.p.s.
Grid			
Unloaded grid drive pulse voltage (see note 5)	175	—	V
Grid pulse duration	2.0	—	μ s
Rate of rise of grid pulse (see note 4)	160	—	V/ μ s
Peak inverse grid voltage	—	200	V
Unloaded grid bias voltage	0	-120	V
Forward impedance of grid drive circuit	—	1500	Ω
Cathode			
Heater voltage	6.3	$+5\%$ -10%	V
Tube heating time	3.0	—	min
Environmental			
Environmental performance			see note 6
Ambient temperature	-50	+90	$^{\circ}$ C
Altitude	—	10 000	ft
	—	3	km

CHARACTERISTICS

	Min	Typical	Max	
Critical d.c. anode voltage for conduction (see note 7)	—	0.3	1.0	kV
Anode delay time (see notes 7 and 8)	—	0.35	0.6	μ s
Anode delay time drift (see notes 7 and 9)	—	0.03	0.1	μ s
Time jitter (see notes 7 and 10)	—	3.0	5.0	ns
Recovery time	see note 11 and curves			
Heater current (at 6.3V)	5.5	6.1	6.7	A

NOTES

1. The tube should preferably be clamped by the base only. Any clamps used on the bulb must not extend beyond 2 inches (50mm) above the top of the base and should be made from material of low thermal conductivity.
2. For instantaneous starting applications the maximum permissible peak forward voltage is 8.0kV and there must be no overshoot.
3. In pulsed operation the peak inverse anode voltage, exclusive of a spike of 0.05 microsecond duration, must not exceed 2.5kV during the first 25 microseconds after the pulse.
4. This rate of rise refers to that part of the leading edge of the pulse between 25% and 75% of the pulse amplitude.
5. Measured with respect to cathode potential.
6. Mechanical Testing. Samples from each production batch are subjected to vibration tests as follows.
 - a) At an acceleration of 10g, 50Hz for one minute.
 - b) At a constant amplitude of 0.040 inch through the range 10Hz to 50Hz to 10Hz.The tests are carried out in two mutually perpendicular directions at right angles to the longitudinal axis of the tube.
7. The typical figures are obtained on test using conditions of minimum grid drive. Improved performance can be expected by increasing the grid drive.
8. The time interval between a point on the leading edge of the unloaded grid pulse at 25% of the pulse amplitude and the point where anode conduction takes place.
9. Normally taken as the drift in delay time over a 5-minute run at full ratings between the second and seventh minutes of operation.
10. The variation of firing time measured at 50% of current pulse amplitude.
11. The recovery characteristics are controlled on a sampling basis.

MAXIMUM RECOVERY CHARACTERISTICS

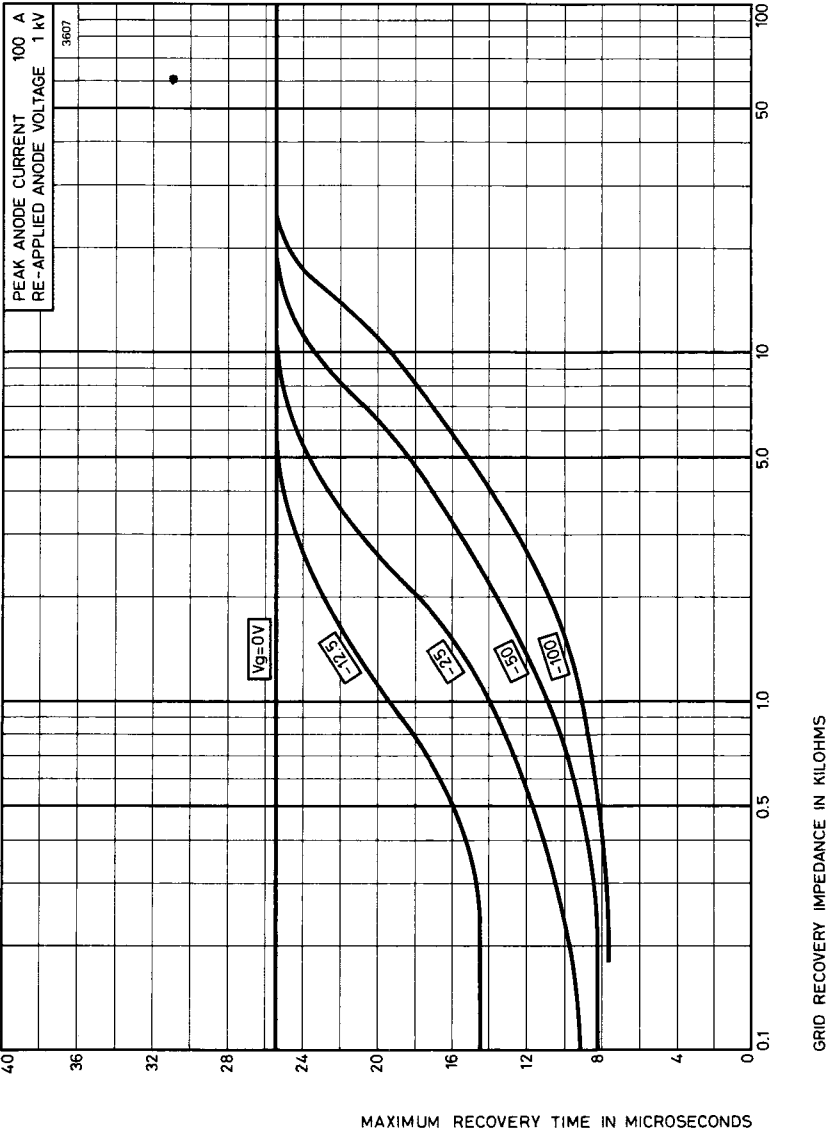

OUTLINE (All dimensions without limits are nominal)

2470

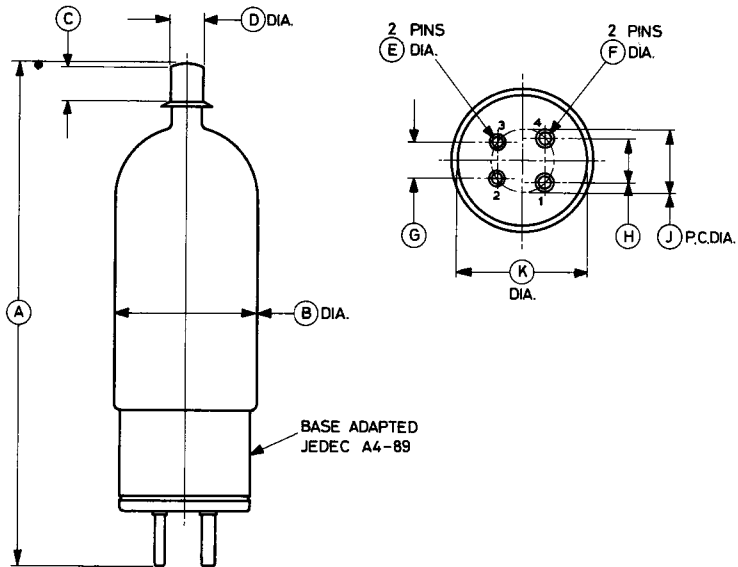

Ref	Inches	Millimetres
A	4.750 ± 0.250	120.7 ± 6.4
B	1.535 max	39.00 max
C	0.268 min	6.81 min
D	0.359 ± 0.003	9.119 ± 0.076
E	0.125 ± 0.003	3.175 ± 0.076
F	0.156 ± 0.003	3.962 ± 0.076
G	0.437	11.10
H	0.468	11.89
J	0.640	16.26
K	1.372	34.85

Pin	Element
1	Heater
2	Cathode
3	Grid
4	Heater, cathode
Top cap	Anode

Millimetre dimensions have been derived from inches except dimension B.



FX2519A/5949A

HYDROGEN THYRATRON

The data to be read in conjunction with the Hydrogen Thyatron Preamble.

ABRIDGED DATA

Hydrogen-filled, positive grid triode thyatron for pulse operation at high peak currents and high voltages. A low reservoir current version of type 5949A, complying with MIL-E-1/1100C.

Peak forward anode voltage	25	kV max
Peak anode current	500	A max
Average anode current	500	mA max
Anode heating factor	6.25×10^9	V.A.p.p.s. max
Peak output power	6.25	MW max

GENERAL

Electrical

Cathode (connected internally to mid-point of heater)	oxide coated
Cathode heater voltage	$6.3 \pm 5\%$ V
Cathode heater current	18.5 A
Reservoir heater voltage (see note 1)	4.5 V
Reservoir heater current	3.0 A
Tube heating time (minimum)	3.0 min

Mechanical

Overall length	12.500 inches (317.5mm) max
Overall diameter	3.312 inches (84.12mm) max
Net weight	1½ pounds (0.7kg) approx
Mounting position	any
Base	pin spacing as B5F, metal shell with micalex insert
Top cap (see note 2)	B.S.448-CT3

Cooling	natural
--------------------------	---------

PULSE MODULATOR SERVICE

MAXIMUM AND MINIMUM RATINGS (Absolute values)

	Min	Max	
Anode			
Peak forward anode voltage (see note 3)	—	25	kV
Peak inverse anode voltage (see note 4)	—	25	kV
Peak anode current	—	500	A
Average anode current	—	500	mA
Rate of rise of anode current (see note 5)	—	2500	A/ μ s
Anode heating factor	—	6.25×10^9	V.A.p.p.s.

Grid

Unloaded grid drive pulse voltage (see note 6)	550	1000	V
Grid pulse duration	2.0	—	μ s
Rate of rise of grid pulse (see note 5)	1.8	—	kV/ μ s
Peak inverse grid voltage	—	450	V
Loaded grid bias voltage	0	-120	V
Forward impedance of grid drive circuit	50	200	Ω

Cathode

Heater voltage	$6.3 \pm 5\%$	—	V
Heating time	3.0	—	min

Reservoir

Heater voltage (see note 1)	3.0	5.0	V
Heating time	3.0	—	min

Environmental

Ambient temperature	-55	+75	$^{\circ}$ C
Altitude	—	10 000	ft
	—	3	km

CHARACTERISTICS

	Min	Typical	Max	
Critical d.c. anode voltage for conduction (see note 7)	—	0.7	4.0	kV
Anode delay time (see notes 7 and 8)	—	0.25	1.0	μ s
Anode delay time drift (see notes 7 and 9)	—	0.02	0.25	μ s
Time jitter (see notes 7 and 10)	—	2.0	5.0	ns
Cathode heater current (at 6.3V)	15	18.5	22	A
Reservoir heater current (at 4.5V)	—	3.0	3.3	A

NOTES

1. The reservoir voltage must be set to within $\pm 5\%$ of the value marked on the tube base.
2. • A large area anode connector MA360 is recommended.
3. This is the maximum forward hold-off voltage imposed on the thyatron in a pulse modulator circuit. Tubes are tested at 27.5kV peak forward anode voltage, with the charging reactor inductance and pulse forming network capacitance resonant at 500p.p.s. For instantaneous starting applications the maximum permissible peak forward voltage is 18kV; this must not be reached in less than 0.04 second and there must be no overshoot.
4. In pulsed operation the peak inverse anode voltage, exclusive of a spike of 0.05 microsecond duration, must not exceed 5.0kV during the first 25 microseconds after the pulse.
5. This rate of rise refers to that part of the leading edge of the pulse between 25% and 75% of the pulse amplitude.
6. Measured with respect to cathode potential.
7. The typical figures are obtained on test using conditions of minimum grid drive. Improved performance can be expected by increasing the grid drive.
8. The time interval between a point on the leading edge of the unloaded grid pulse at 25% of the pulse amplitude and the point where anode conduction takes place.
9. Normally taken as the drift in delay time over a 5-minute run at full ratings between the second and seventh minutes of operation.
10. The variation of firing time measured at 50% of current pulse amplitude.

X-RAY WARNING

X-rays are emitted by the FX2519A/5949A from the region of the anode, but the radiation is usually reduced to a safe level by the steel panels of the equipment in which the tube operates.

Whilst EEV has taken care to ensure the accuracy of the information contained herein it accepts no responsibility for the consequences of any use thereof and also reserves the right to change the specification of goods without notice. EEV accepts no liability beyond that set out in its standard conditions of sale in respect of infringement of third party patents arising from the use of tubes or other devices in accordance with information contained herein.

OUTLINE (All dimensions without limits are nominal)

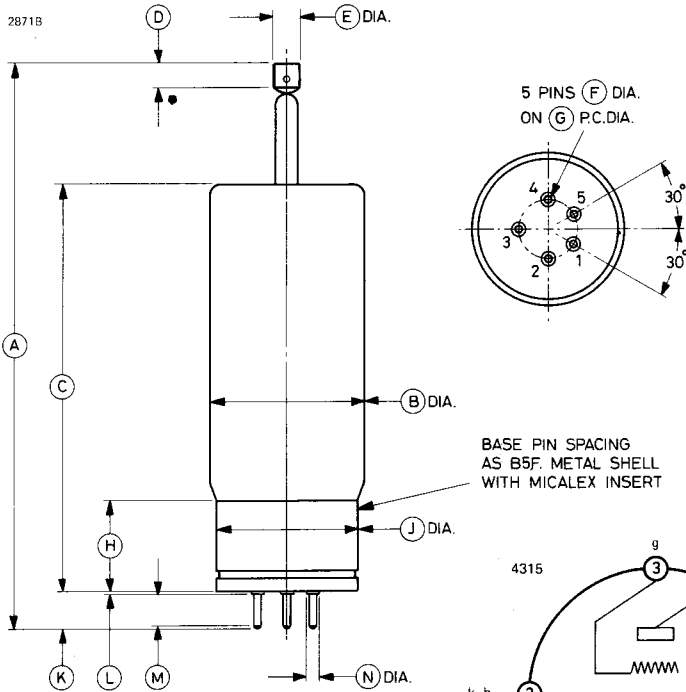

Ref	Inches	Millimetres
A	12.000 ± 0.500	304.8 ± 12.7
B	3.312 max	84.12 max
C	8.500 ± 0.500	215.9 ± 12.7
D	0.500 min	12.70 min
E	0.566 ± 0.007	14.38 ± 0.18
F	0.187 ± 0.003	4.750 ± 0.076
G	1.250	31.75
H	1.937	49.20
J	3.062 ± 0.062	77.77 ± 1.57
K	0.770 max	19.56 max
L	0.073 max	1.85 max
M	0.575 min	14.60 min
N	0.260 max	6.60 max

Millimetre dimensions have been derived from inches.

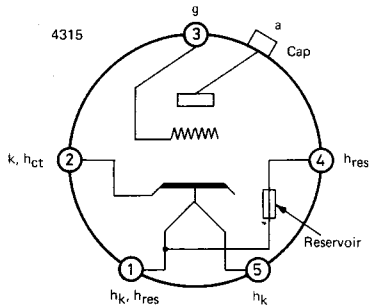

Pin	Element
1	Heater, reservoir
2	Cathode, connected internally to heater mid-point
3	Grid
4	Reservoir
5	Heater
Top cap	Anode

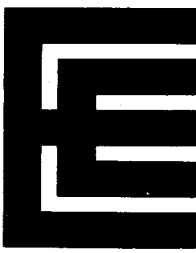

HYDROGEN THYRATRON

The data to be read in conjunction with the Hydrogen Thyatron Preamble.

ABRIDGED DATA

Ruggedized hydrogen-filled triode thyatron, positive grid, for pulse operation. A hydrogen reservoir is incorporated.

Peak forward anode voltage	16	kV max
Peak anode current (see note 1)	200	A max
Average anode current	200	mA max
Anode heating factor	3.0×10^9	V.A.p.p.s. max
Peak output power	1.6	MW max

GENERAL

Electrical

Cathode (connected internally to one end of heater)	oxide coated
Heater voltage	$6.3 \pm 7.5\%$ V
Heater current	6.1 A
Tube heating time (minimum)	3.0 min

Mechanical

Overall length	6.250 inches (158.8mm) max
Overall diameter	1.535 inches (38.99mm) max
Net weight	4 ounces (110g) approx
Mounting position	any
Base	JEDEC A4-89 (UX4) 4-pin
Top cap	B.S.448-CT3

Cooling	natural
--------------------------	---------

PULSE MODULATOR SERVICE

MAXIMUM AND MINIMUM RATINGS (Absolute values)

	Min	Max	
Anode			
Peak forward anode voltage (see note 2)	—	16	kV
Peak inverse anode voltage (see note 3)	—	16	kV
Peak anode current (see note 1)	—	200	A
Average anode current	—	200	mA
Rate of rise of anode current (see note 4)	—	1500	A/ μ s
Anode heating factor	—	3.0×10^9	V.A.p.p.s.

Grid

Unloaded grid drive pulse voltage (see notes 5 and 6)	200	—	V
Grid pulse duration	2.0	—	μ s
Rate of rise of grid pulse (see note 4)	180	—	V/ μ s
Peak inverse grid voltage	—	200	V
Loaded grid bias voltage	0	-120	V
Forward impedance of grid drive circuit	50	500	Ω

Cathode

Heater voltage	$6.3 \pm 7\frac{1}{2}\%$		V
Tube heating time	3.0	—	min

Environmental

Ambient temperature	-50	+90	$^{\circ}$ C
Altitude	—	10 000	ft
	—	3	km

CHARACTERISTICS

	Min	Typical	Max	
Critical d.c. anode voltage for conduction (see note 6)	—	0.3	1.0	kV
Anode delay time (see notes 6 and 7)	—	0.3	0.65	μ s
Anode delay time drift (see notes 6 and 8)	—	0.03	0.1	μ s
Time jitter (see notes 6 and 9)	—	3.0	5.0	ns
Recovery time				see note 10 and curves
Heater current (at 6.3V)	5.5	6.1	6.7	A
Additional tests				see note 11

NOTES

1. Under fault conditions the peak anode current rating may be increased to 350A.
2. This is the maximum forward hold-off voltage imposed on the thyatron in a pulse modulator circuit. Tubes are tested at 18kV peak forward anode voltage, with the charging reactor inductance and pulse forming network capacitance resonant at 1000p.p.s. For instantaneous starting applications the maximum permissible peak forward voltage is 13.5kV; this must not be reached in less than 0.04 second and there must be no overshoot.
3. In pulsed operation the peak inverse anode voltage, exclusive of a spike of 0.05 microsecond duration, must not exceed 5.0kV during the first 25 microseconds after the pulse.
4. This rate of rise refers to that part of the leading edge of the pulse between 25% and 75% of the pulse amplitude.
5. Measured with respect to cathode potential.
6. The typical figures are obtained on test using conditions of minimum grid drive. Improved performance can be expected by increasing the grid drive.
7. The time interval between a point on the leading edge of the unloaded grid pulse at 25% of the pulse amplitude and the point where anode conduction takes place.
8. Normally taken as the drift in delay time over a 5-minute run at full ratings between the second and seventh minutes of operation.
9. The variation of firing time measured at 50% of current pulse amplitude.
10. The recovery characteristics are controlled on a sampling basis.
11. In addition to operational testing at pulse repetition rates of 800 and 1000p.p.s. on all tubes, an additional test at 2500p.p.s., 12.5kV, is performed on a sampling basis.

X-RAY WARNING

X-rays are emitted by the FX2525 from the region of the anode, but the radiation is usually reduced to a safe level by the steel panels of the equipment in which the tube operates.

MAXIMUM RECOVERY CHARACTERISTICS

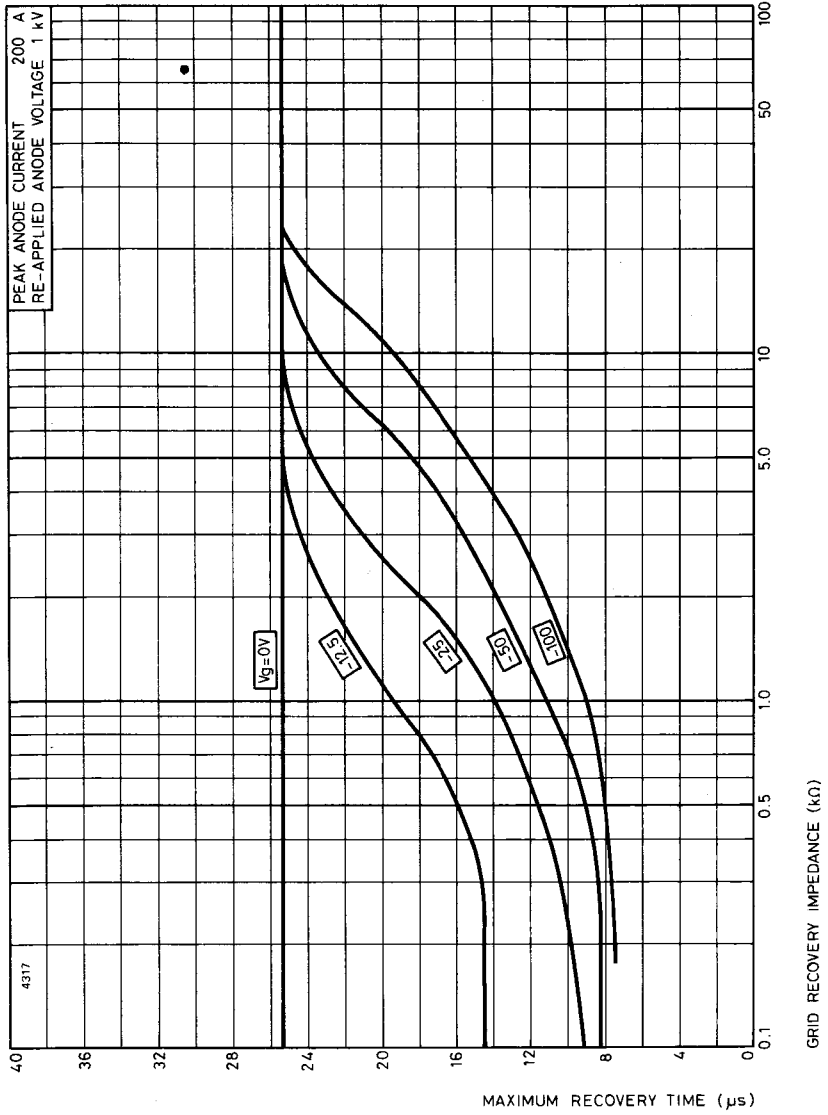

Whilst EEV has taken care to ensure the accuracy of the information contained herein it accepts no responsibility for the consequences of any use thereof and also reserves the right to change the specification of goods without notice. EEV accepts no liability beyond that set out in its standard conditions of sale in respect of infringement of third party patents arising from the use of tubes or other devices in accordance with information contained herein.

OUTLINE (All dimensions without limits are nominal)

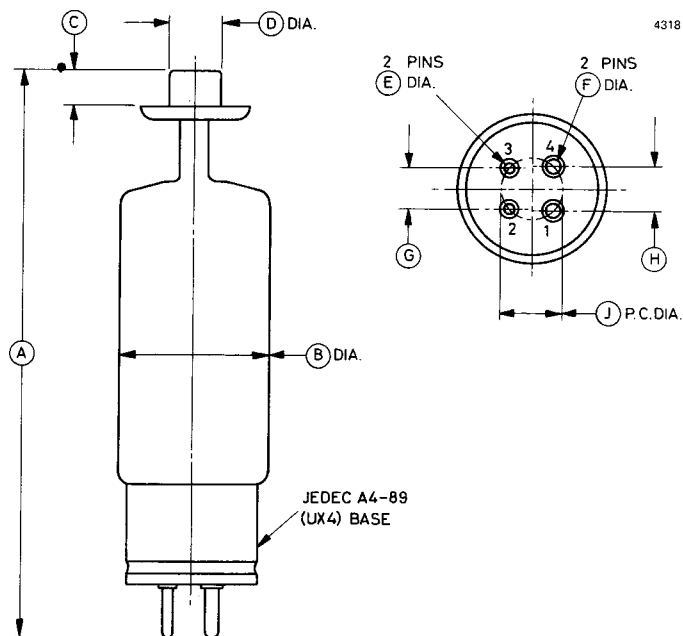

Ref	Millimetres	Inches
A	152.4 ± 6.4	6.000 ± 0.250
B	38.99 max	1.535 max
C	9.50 min	0.375 min
D	14.38 ± 0.13	0.566 ± 0.005
E	3.18	0.125
F	3.96	0.156
G	11.10	0.437
H	11.89	0.468
J	16.26	0.640

Pin	Element
1	Heater
2	Cathode
3	Grid
4	Heater, cathode
Top cap	Anode

Inch dimensions have been derived from millimetres.

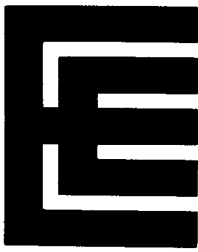

HYDROGEN THYRATRON

The data to be read in conjunction with the Hydrogen Thyatron Preamble.

ABRIDGED DATA

Hydrogen-filled triode thyatron, positive grid, for pulse operation especially in compact airborne radar systems. A hydrogen reservoir operating from the cathode heater supply is incorporated.

Peak forward anode voltage	8.0	kV max
Peak anode current	85	A max
Average anode current	100	mA max
Anode heating factor	2.5×10^9	V.A.p.p.s. max
Peak output power	0.34	MW max

GENERAL

Electrical

Cathode (connected internally to one end of heater)		oxide coated
Heater voltage	6.3	V
Heater current	3.0	A
Cathode heating time (minimum)	3.0	min

Mechanical

Overall length	4.375 inches (111.1mm) max
Overall diameter	1.560 inches (39.62mm) max
Net weight	2 ounces (60g) approx
Mounting position	any
Clamping	see note 1
Base	adapted JEDEC A4-89
Top cap	B.S.448-CT2

Cooling	see note 2
--------------------------	------------

MAXIMUM AND MINIMUM RATINGS (Absolute values)

	Min	Max	
Anode			
Peak forward anode voltage	—	8.0	kV
Peak inverse anode voltage (see note 3)	—	8.0	kV
Peak anode current	—	85	A
Average anode current	—	100	mA
Rate of rise of anode current (see note 4)	—	1200	A/ μ s
Anode heating factor	—	2.5×10^9	V.A.p.p.s.

Grid

Unloaded grid drive pulse amplitude	175	—	V
Unloaded grid pulse length	2.0	—	μ s
Rate of rise of grid pulse (see note 4)	350	—	V/ μ s
Peak inverse grid voltage	—	200	V
Forward impedance of grid drive circuit	—	1500	Ω

Cathode

Heater voltage	5.7	6.9	V
Cathode heating time	3.0	—	min

Environmental

Ambient temperature	−50	+90	$^{\circ}$ C
-------------------------------	-----	-----	--------------

CHARACTERISTICS

	Min	Typical	Max	
Critical d.c. anode voltage for conduction (see notes 5 and 6)	—	200	800	V
Anode delay time (see notes 6 and 7)	—	0.35	0.5	μ s
Anode delay time drift (see notes 6 and 8)	—	0.03	0.1	μ s
Jitter (see notes 6 and 9)	—	3	5	ns
Recovery time				see note 10 and curves
Heater current (at 6.3V)	2.5	3.0	3.5	A

NOTES

1. The tube should preferably be clamped by the base only. Any clamps used on the bulb must be insulated from ground.
2. Cooling of the anode lead is permissible, but no forced air flow should be directed on to the bulb.
3. In pulsed operation the peak inverse anode voltage, exclusive of a spike of 0.05 microsecond duration, must not exceed 3.0kV during the first 25 microseconds after the pulse.
4. This rate of rise refers to that part of the leading edge of the pulse between 25% and 75% of the pulse amplitude.
5. The minimum supply voltage at which the tube will conduct decreases as the grid drive current is increased. A typical value of 200 volts is easily obtained. This in no way affects the ability of the tube to recover.
6. The typical figures are more realistic for tubes operating under normal conditions.
7. The time interval between a point on the leading edge of the unloaded grid pulse at 25% of the pulse amplitude and the point where anode conduction takes place.
8. Normally taken as the drift in delay time over a 5 minute run at full ratings between the second and seventh minutes of operation.
9. The variation of firing time measured at 50% of current pulse amplitude.
10. The recovery characteristics are controlled on a sampling basis.

MAXIMUM RECOVERY CHARACTERISTICS

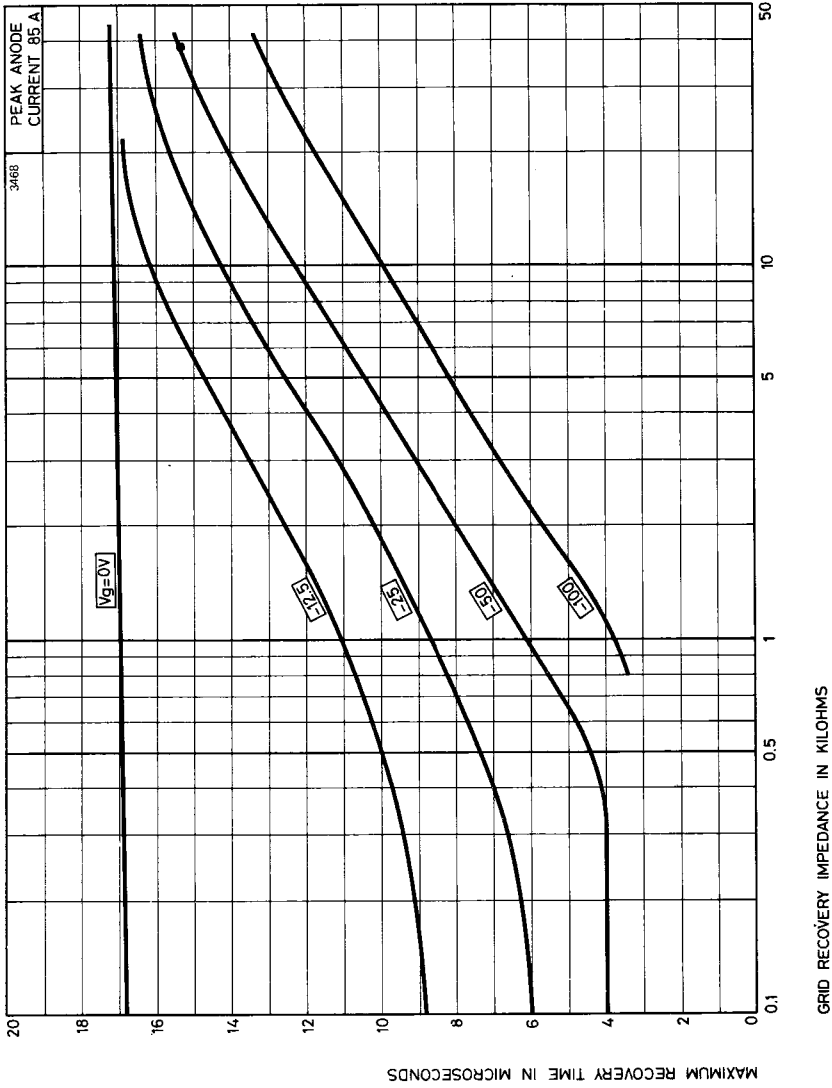

OUTLINE (All dimensions without limits are nominal)

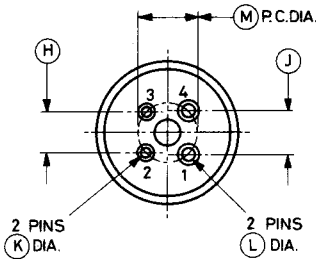
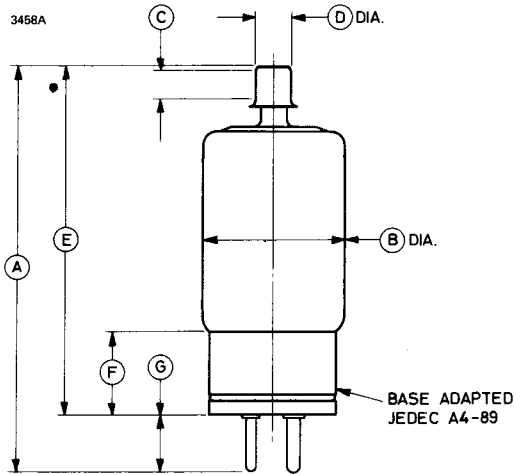

Pin	Element
1	Heater
2	Cathode
3	Grid
4	Heater, cathode
Top cap	Anode

Ref	Inches	Millimetres	Ref	Inches	Millimetres
A	4.250 ± 0.125	108.0 ± 3.2	G	0.596 max	15.14 max
B	1.500 ± 0.060	38.10 ± 1.52	H	0.437	11.10
C	0.300 min	7.62 min	J	0.468	11.89
D	0.365 max	9.27 max	K	0.125 ± 0.003	3.175 ± 0.076
E	3.687 ± 0.125	93.65 ± 3.18	L	0.156 ± 0.003	3.962 ± 0.076
F	0.875	22.23	M	0.640	16.26

Millimetre dimensions have been derived from inches.

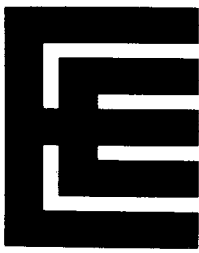

HYDROGEN-FILLED CERAMIC THYRATRON

The data to be read in conjunction with the Hydrogen Thyatron Preamble.

ABRIDGED DATA

Hydrogen-filled triode thyatron with ceramic envelope, positive grid, for pulse operation. Suitable for use in compact airborne military radar systems. A hydrogen reservoir operating from the heater supply is incorporated.

Peak forward anode voltage	16	kV max
Peak anode current	150	A max
Average anode current	450	mA max
Anode heating factor	7.2×10^9	V.A.p.p.s. max

GENERAL

Electrical

Cathode (connected internally to one end of heater)	oxide coated
Cathode heater voltage	$6.3 \pm 7.5\%$ V
Cathode heater current	7.5 A
Reservoir heater voltage (see note 1)	$6.3 \pm 7.5\%$ V
Reservoir heater current	1.5 A
Tube heating time (minimum)	3.0 min

Mechanical

Overall length	119.83mm (4.718 inches) max
Overall diameter	58.41mm (2.300 inches) max
Net weight	450g (1 pound) approx
Mounting position	any

PULSE MODULATOR SERVICE

MAXIMUM AND MINIMUM RATINGS (Absolute values)

Anode	Min	Max	
Peak forward anode voltage (see note 2)	—	16	kV
Peak inverse anode voltage (see note 3)	—	16	kV
Peak anode current	—	150	A
Average anode current	—	450	mA
Rate of rise of anode current (see note 4)	—	1500	A/ μ s
Anode heating factor	—	7.2×10^9	V.A.p.p.s.

Grid

Unloaded grid drive pulse voltage (see note 5)	200	—	V
Grid pulse duration	2.0	—	μ s
Rate of rise of grid pulse (see note 4)	180	—	V/ μ s
Peak inverse grid voltage	—	200	V
Loaded grid bias voltage	0	-120	V
Forward impedance of grid drive circuit	50	500	Ω

Cathode

Heater voltage	$6.3 \pm 7\frac{1}{2}\%$		V
Heating time	3.0	—	min

Reservoir

Heater voltage (see note 1)	$6.3 \pm 7\frac{1}{2}\%$		V
Heating time	3.0	—	min

Environmental

Environmental performance			see note 6
Ambient temperature	-40	+100	$^{\circ}$ C
Altitude	—	10 000	ft
	—	3	km

CHARACTERISTICS

	Min	Max	
Critical d.c. anode voltage for conduction (see note 7)	—	1.0	kV
Anode delay time (see notes 7 and 8)	—	0.5	μs
Anode delay time drift (see notes 7 and 9)	—	0.1	μs
Time jitter (see notes 7 and 10)	—	5.0	ns
Heater and reservoir current (at 6.3V)	7.5	11.5	A
Additional tests			see note 11

NOTES

1. The reservoir heater supply must be obtained either from the cathode heater supply or if a separate supply is used it must be decoupled to avoid damage to the reservoir.
2. This is the maximum forward hold-off voltage imposed on the thyatron in a pulse modulator circuit. Tubes are tested at 16kV peak forward anode voltage, with the charging reactor inductance and pulse forming network capacitance resonant at 1000p.p.s. For instantaneous starting applications the maximum permissible peak forward voltage is 16kV; this must not be reached in less than 0.04 second and there must be no overshoot.
3. In pulsed operation the peak inverse anode voltage, exclusive of a spike of 0.05 microsecond duration, must not exceed 5.0kV during the first 25 microseconds after the pulse.
4. This rate of rise refers to that part of the leading edge of the pulse between 25% and 75% of the pulse amplitude.
5. Measured with respect to cathode potential.
6. All tubes are subjected to an acceleration of 10g at 50Hz before testing. In addition, samples are tested under the following conditions:
 - (a) Operation under Vibration — The tubes are vibrated at 10g in each of three planes at a sweep rate of one octave per minute from 20 to 500 to 20Hz, under normal operating conditions.

- (b) Survival under Vibration and Heater Cycling — The tubes are vibrated at 10g at a sweep rate of one octave per minute from 5 to 500Hz for 70 hours in each plane together with heater cycling of a 10 minute on/off cycle.
7. The typical figures are obtained on test using conditions of minimum grid drive. Improved performance can be expected by increasing the grid drive.
 8. The time interval between a point on the leading edge of the unloaded grid pulse at 25% of the pulse amplitude and the point where anode conduction takes place.
 9. Normally taken as the drift in delay time over a 5-minute run at full ratings between the second and seventh minutes of operation.
 10. The variation of firing time measured at 50% of current pulse amplitude.
 11. In addition to operational testing at pulse repetition rates of 800 and 1000p.p.s. on all tubes, an additional test at 2500p.p.s., 14kV, is performed on a sampling basis.

X-RAY WARNING

X-rays are emitted by the FX2531 from the region of the anode, but the radiation is usually reduced to a safe level by the metal panels of the equipment in which the tube operates.

OUTLINE NOTES

1. Connections for the cathode, cathode heater return and reservoir heater return.
2. The cover must not be used as a conductor.

OUTLINE (All dimensions without limits are nominal)

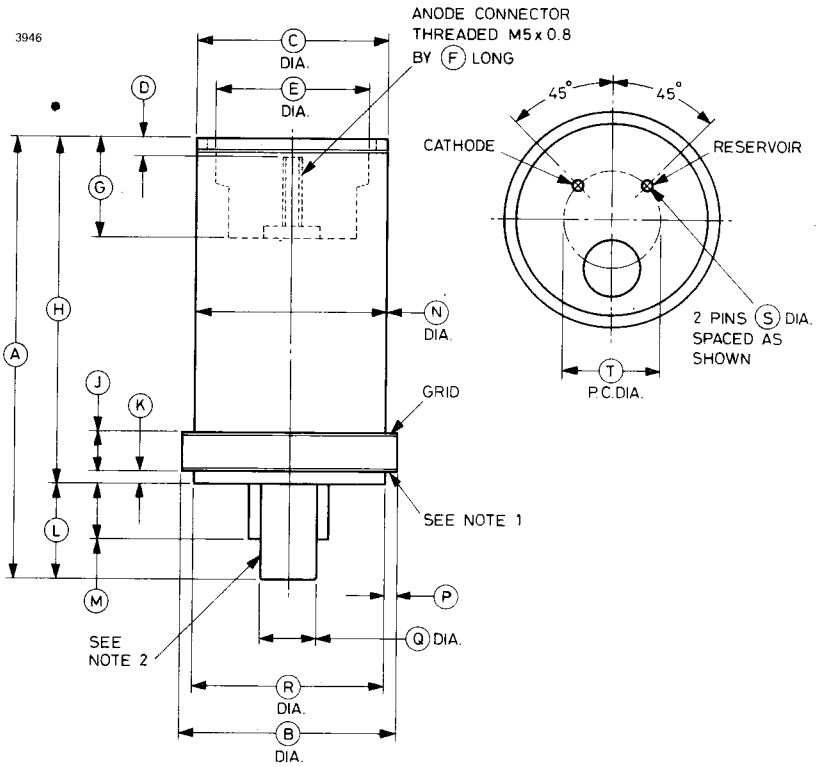

Ref	Millimetres	Inches	Ref	Millimetres	Inches
A	119.83 max	4.718 max	K	3.17 ± 0.76	0.125 ± 0.030
B	57.65 + 0.76 - 0.63	2.270 + 0.030 - 0.025	L	25.40 max	1.000 max
C	50.80 ± 0.38	2.000 ± 0.015	M	15.87 max	0.625 max
D	6.35 max	0.250 max	N	50.80 ± 0.38	2.000 ± 0.015
E	41.14 ± 2.54	1.620 ± 0.100	P	2.38 min	0.094 min
F	15.87 min	0.625 min	Q	16.13 max	0.635 max
G	26.16 ± 3.17	1.030 ± 0.125	R	50.80 ± 0.38	2.000 ± 0.015
H	91.26 ± 3.17	3.593 ± 0.125	S	3.17 ± 0.15	0.125 ± 0.006
J	10.79 + 0.38 - 0.76	0.425 + 0.015 - 0.030	T	25.40	1.000

Inch dimensions have been derived from millimetres.

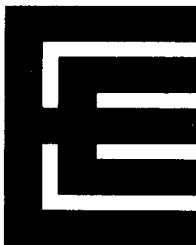

ACCESSORIES FOR HYDROGEN THYRATRONS

The following top cap connectors and sockets are available from English Electric Valve Company Ltd., for use with EEV hydrogen thyratrons.

Type	Outline	Description
MA91	Page 4	A five-contact (B5F) socket with flexible leads and terminal tags, and mounted on an insulating base plate. It provides a conversion from base to flange type mounting.
MA92	Page 5	Similar to MA91 but incorporates an RC network, and is designed for use with tetrodes such as CX1140 and where a single pulse drive and flying lead connections are required.
MA94	Page 6	B5F socket with 3.750 inch diameter mounting flange.
MA153	Page 7	Flange-mounted B5F socket with a base clamp.
MA153A	Page 8	Flange-mounted B5F socket.
MA153B	Page 9	B5F socket with 4.875 inch diameter mounting flange.
MA179	Page 10	MA92 with a base clamp.
MA275	Page 11	B5F socket with base clamp; small diameter.
MA356	Page 12	UX4 socket.
MA357	Page 13	B4D socket with base clamp; Tufnol mounting plate.
MA357B	Page 14	B4D socket with ceramic mounting plate.

Continued on page 2

Type	Outline	Description
MA358	Page 15	Top cap connector for 0.359 inch diameter cap.
MA359†	Page 15	Top cap connector for 0.566 inch diameter cap.
MA360†	Page 16	Heat-dissipating top cap connector for 0.566 inch diameter cap.
MA360A†	Page 16	Lightweight, heat-dissipating, anti-corona top cap connector for 0.566 inch diameter cap.

† The MA360 has been designed primarily for heat dissipation and is relatively massive, weighing 75g. When the thyatron is intended for operation under conditions where heat dissipation and corona problems are encountered, the connector MA360A should be used (weight 35g). The lightweight connector MA359 (weight 3g) is recommended where the operating conditions include shock and vibration, but only if the heat dissipation is low otherwise air cooling is necessary.

Tube Type	Top Cap Connector	Socket
6587	MA359	MA357, MA357B
8508	MA359	MA357, MA357B
CX1140	MA360	MA91*, MA92* MA94, MA153 MA153A, MA153B MA179*, MA275
CX1159	MA360	MA91*, MA92* MA94, MA153 MA153A, MA153B MA179*, MA275
CX1191	MA359, MA360, MA360A‡	MA357, MA357B
CX1191A	MA359, MA360, MA360A‡	MA357, MA357B
CX1191D	MA359, MA360, MA360A‡	MA357, MA357B
FX227	MA358	MA356
FX297	MA360	MA91, MA94 MA153, MA153A MA153B, MA275
FX2503	Special, supplied with tube	MA91, MA94 MA153, MA153A MA153B, MA275
FX2505	MA359	MA357, MA357B
FX2517	MA358	MA356
FX2519A/5949A	MA360, MA360A	MA91, MA94 MA153, MA153A MA153B, MA275
FX2530/6777	MA358	MA356

* For conversion applications

‡ See footnote on page 2

SOCKET ASSEMBLY MA91

See pages 1 and 3 for further details.

2910A

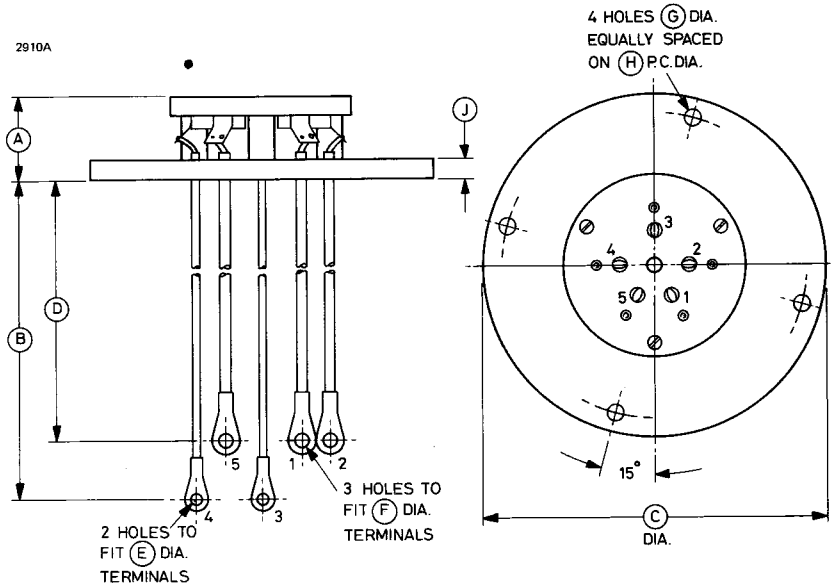

Ref	Inches	Millimetres
A	1.500	38.10
B	11.000 min	280.0 min
C	6.000	152.4
D	10.000 min	254.0 min
E*	0.197	5.00
F*	0.236	6.00
G	0.312	7.92
H	5.344 ± 0.020	135.7 ± 0.5
J	0.375	9.53

Lead	Colour
1	Yellow (heater)
2	Black (cathode)
3	White (grid 2)
4	Blue (grid 1)
5	Yellow (heater)

Millimetre dimensions have been derived from inches except where indicated thus *.

All dimensions without limits are nominal.

SOCKET ASSEMBLY MA92

See pages 1 and 3 for further details.

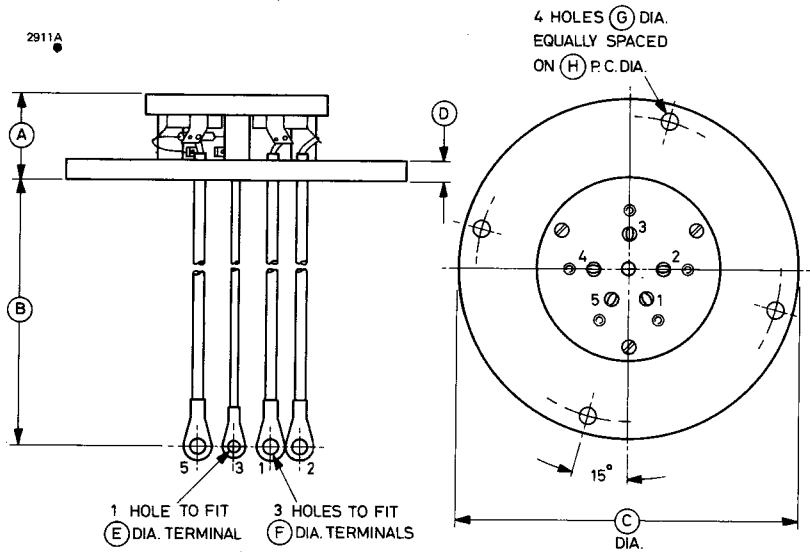

Ref	Inches	Millimetres	Lead	Colour
A	1.500	38.10	1	Yellow (heater)
B	8.000 min	203.2 min	2	Black (cathode)
C	6.000	152.4	3	Green (grid)
D	0.375	9.53	5	Yellow (heater)
E*	0.197	5.00		
F*	0.236	6.00		
G	0.312	7.92		
H	5.344 ± 0.020	135.7 ± 0.5		

Millimetre dimensions have been derived from inches except where indicated thus*.

All dimensions without limits are nominal.

SOCKET MA94

See pages 1 and 3 for further details.

2916A

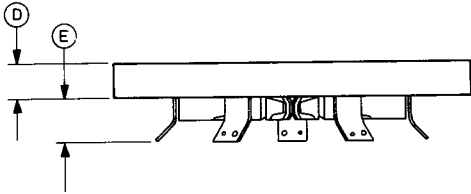
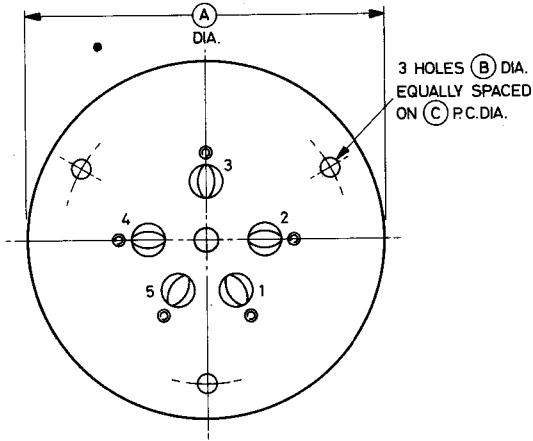

Ref	Inches	Millimetres
A	3.750	95.25
B	0.188	4.78
C	3.000	76.20
D	0.375	9.53
E	0.500 max	12.70 max

Millimetre dimensions have been derived from inches.

All dimensions without limits are nominal.

SOCKET ASSEMBLY MA153

See pages 1 and 3 for further details.

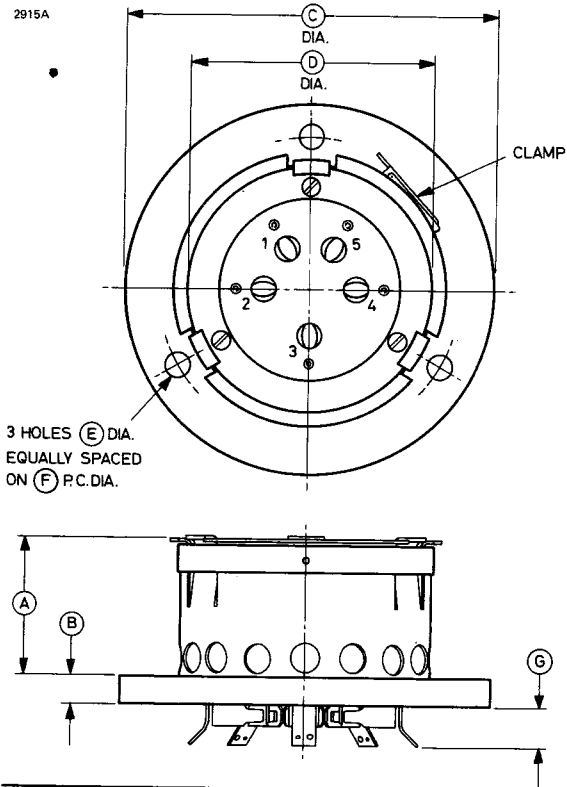

Ref	Inches	Millimetres
A	1.812	46.02
B	0.375	9.53
C	4.875	123.8
D	3.156 ± 0.031	80.16 ± 0.79
E	0.312	7.92
F	4.000	101.6
G	0.500 max	12.70 max

Millimetre dimensions have been derived from inches.

All dimensions without limits are nominal.

SOCKET MA153A

See pages 1 and 3 for further details.

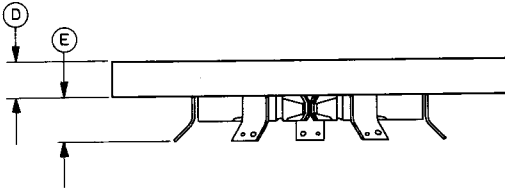
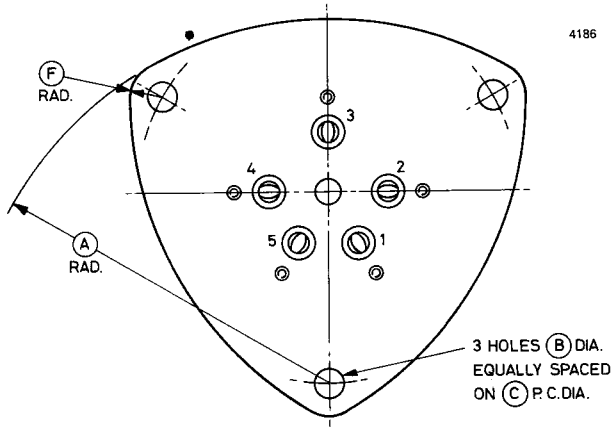

Ref	Inches	Millimetres
A	3.812	96.82
B	0.312	7.92
C	4.000	101.6
D	0.375	9.53
E	0.500 max	12.70 max
F	0.343	8.71

Millimetre dimensions have been derived from inches.

All dimensions without limits are nominal.

SOCKET MA153B

See pages 1 and 3 for further details.

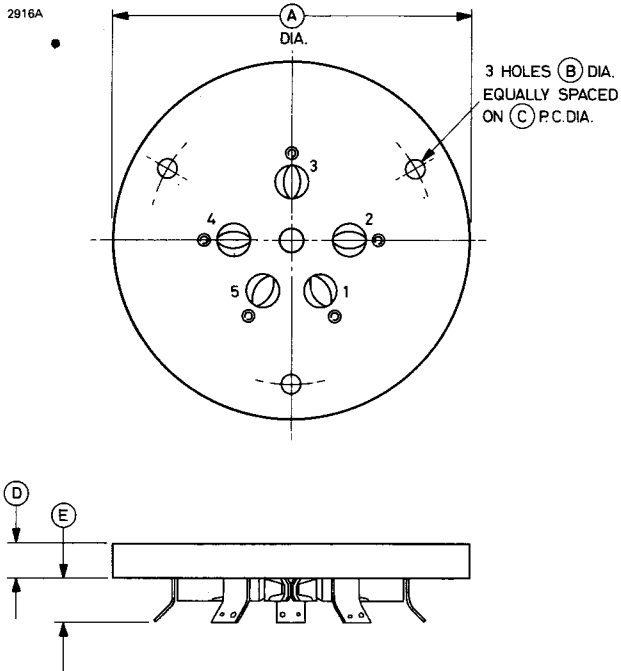

Ref	Inches	Millimetres
A	4.875	123.8
B	0.188	4.78
C	3.000	76.20
D	0.375	9.53
E	0.500 max	12.70 max

Millimetre dimensions have been derived from inches.

All dimensions without limits are nominal.

SOCKET ASSEMBLY MA179

See pages 1 and 3 for further details.

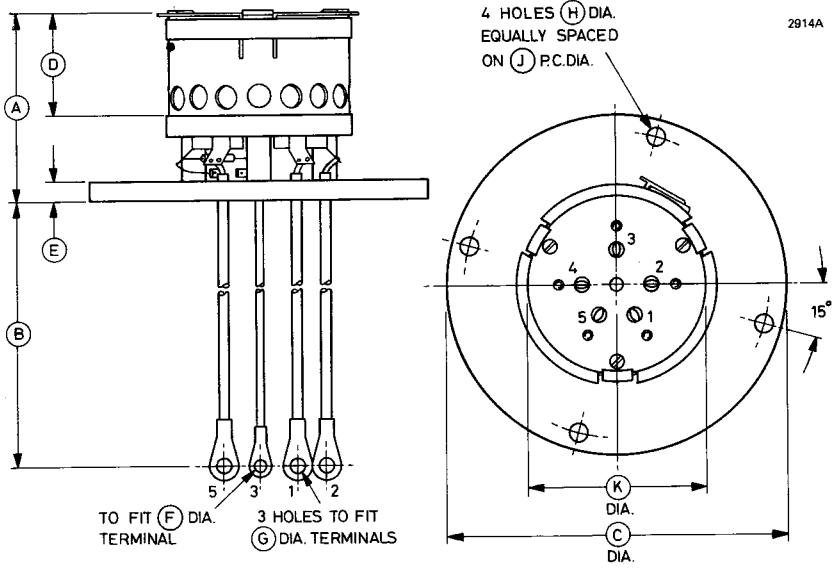

Ref	Inches	Millimetres	Lead	Colour
A	3.312	84.12	1	Yellow (heater)
B	8.000 min	203.2 min	2	Black (cathode)
C	6.000 ± 0.031	152.4 ± 0.8	3	Green (grid)
D	1.813 ± 0.031	46.05 ± 0.79	5	Yellow (heater)
E	0.375 ± 0.031	9.53 ± 0.79		
F*	0.197	5.00		
G*	0.236	6.00		
H	0.312	7.92		
J	5.344 ± 0.020	135.7 ± 0.5		
K	3.094 ± 0.016	78.59 ± 0.41		

Millimetre dimensions have been derived from inches except where indicated thus*.

All dimensions without limits are nominal.

SOCKET ASSEMBLY MA275 (All dimensions are nominal)

See pages 1 and 3 for further details.

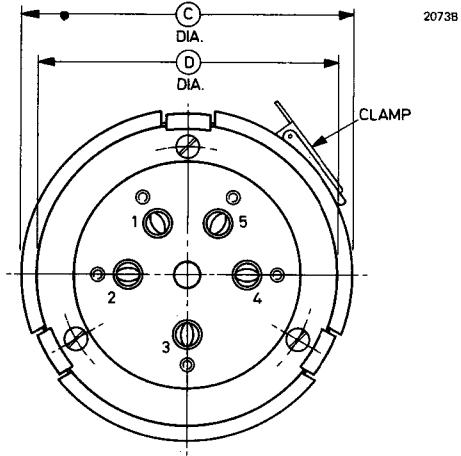

Ref	Inches	Millimetres
A	1.813	46.05
B	0.375	9.53
C	3.500	88.90
D	3.093	78.56
E	1.062	26.97
F	2.687	68.25
G	3.188	80.98

Millimetre dimensions have been derived from inches.

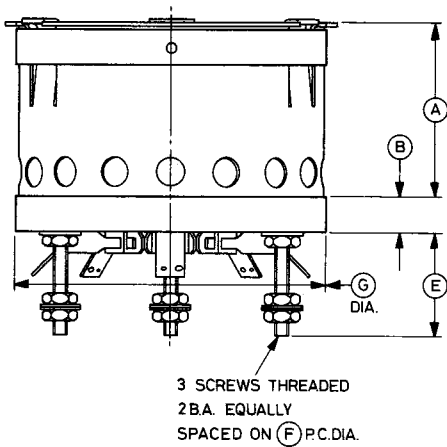

SOCKET MA356

See pages 1 and 3 for further details.

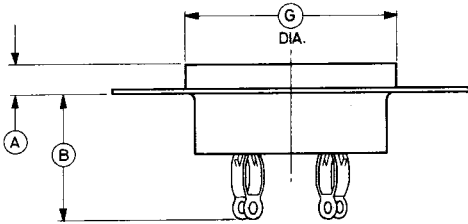
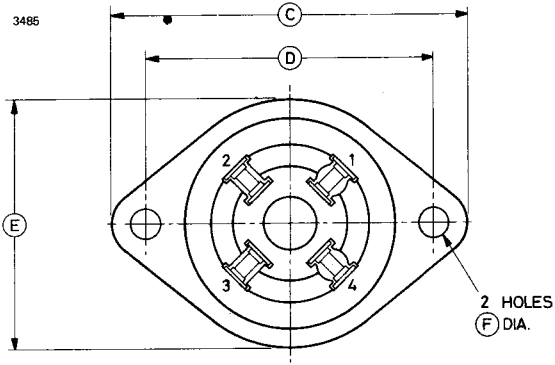

Ref	Inches	Millimetres
A	0.250 max	6.35 max
B	0.750 max	19.05 max
C	1.875 max	47.63 max
D	1.500 ± 0.005	38.10 ± 0.13
E	1.313 max	33.35 max
F	0.156 ± 0.005	3.96 ± 0.13
G	1.219 max	30.96 max

Millimetre dimensions have been derived from inches.

SOCKET ASSEMBLY MA357

See pages 1 and 3 for further details.

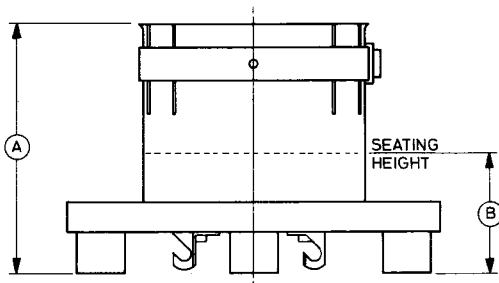
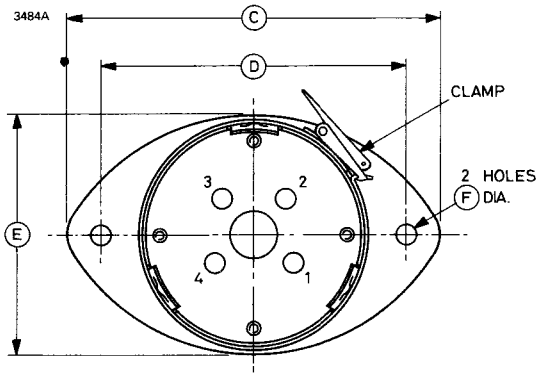

Ref	Inches	Millimetres
A	2.688 max	68.28 max
B	1.281 max	32.54 max
C	4.000 max	101.6 max
D	3.188 ± 0.005	80.98 ± 0.13
E	2.500 ± 0.062	63.50 ± 1.57
F	$0.203 \begin{matrix} +0.005 \\ -0.000 \end{matrix}$	$5.16 \begin{matrix} +0.13 \\ -0.00 \end{matrix}$

Millimetre dimensions have been derived from inches.

SOCKET ASSEMBLY MA357B

See pages 1 and 3 for further details.

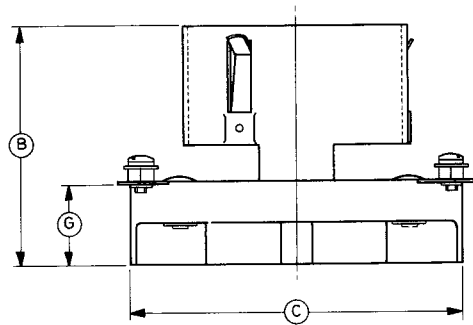
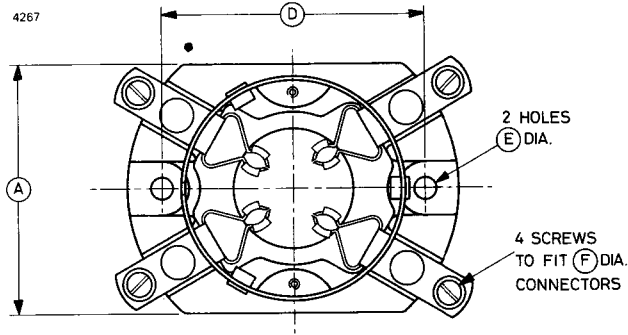

Ref	Inches	Millimetres
A	2.625	66.68
B	2.500	63.50
C	3.500	88.90
D	2.750	69.85
E	0.234	5.94
F	0.187	4.75
G	0.875	22.23

Millimetre dimensions have been derived from inches.

MA358

See pages 2 and 3 for further details.

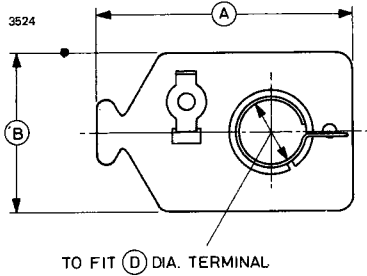

Ref	Inches	Millimetres
A	1.375 max	34.93 max
B	0.860 max	21.84 max
C	0.625 max	15.88 max
D	0.359	9.12

Millimetre dimensions have been derived from inches.

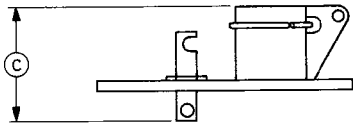

MA359 (All dimensions are nominal)

See pages 2 and 3 for further details.

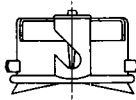
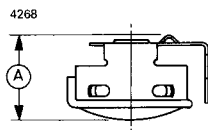

TO FIT (B) DIA.
TERMINAL

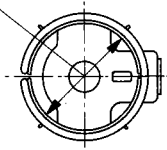

Ref	Inches	Millimetres
A	0.500	12.70
B	0.566	14.38

Millimetre dimensions have been derived from inches.

Whilst EEV has taken care to ensure the accuracy of the information contained herein it accepts no responsibility for the consequences of any use thereof and also reserves the right to change the specification of goods without notice. EEV accepts no liability beyond that set out in its standard conditions of sale in respect of infringement of third party patents arising from the use of tubes or other devices in accordance with information contained herein.

MA360 (All dimensions are nominal)

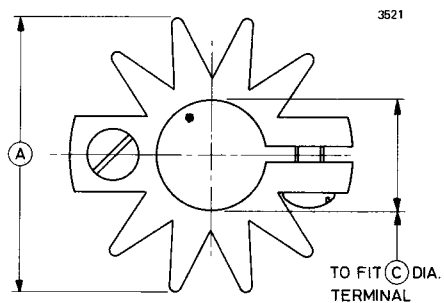

Ref	Inches	Millimetres
A	1.500	38.10
B	0.625	15.88
C	0.566	14.38

Millimetre dimensions have been derived from inches.

THREADED 8-32 N.C.

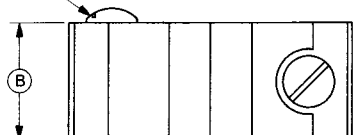

MA360A (All dimensions are nominal)

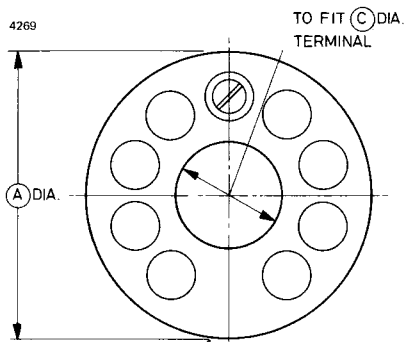

Ref	Inches	Millimetres
A	1.500	38.10
B	0.625	15.88
C	0.566	14.38
D	0.187	4.75

Millimetre dimensions have been derived from inches.

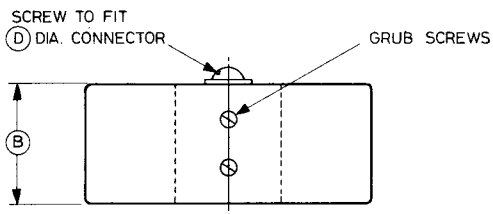



MA391

CURRENT PULSE MEASUREMENT TRANSFORMER

DESCRIPTION

The MA391 is a pulse current transformer intended for simple measurement and observation of current pulses through a thyratron or cable. The current flow is transformed to a voltage output suitable for display on an oscilloscope. Four current/voltage ratios are available (see table below).

The measurement or observation is carried out, for example, simply by removing the thyratron anode connection, placing the transformer over the tube and replacing the connection. The transformer can be allowed to rest wherever convenient but for safety reasons, its metal case must be at or near earth potential; it can be earthed via the outer screen of the signal cable. For accurate results, the case of the transformer must be isolated from the pulse circuit, and when used on a cable it should be supported so that the cable passes approximately through the centre of the transformer aperture. The output connection is a 50 ohm BNC socket and waveforms of a few nanoseconds duration can be observed.

The transformer is fully screened against electrostatic interference and is contained in a rugged cast aluminium housing.

The output matched load is contained within the transformer housing and the terminating impedance of the oscilloscope is non-critical within broad limits. However, if the oscilloscope input impedance is less than 5000 ohms the current calibration of the transformer will be affected although the waveform will not.

Trans- former type	Current for 1 V output (A)	Voltage for 1 kA input (V)	Maximum current (A) (see note 1)	Maximum amp-second rating (see note 2)	Maximum percentage droop (per μ s)
MA391	20	50	10 000	2.8×10^{-2}	3.5
MA391A	50	20	25 000	7×10^{-2}	1.4
MA391B	100	10	50 000	1.4×10^{-1}	0.7
MA391C	200	5	100 000	2.8×10^{-1}	0.4

NOTES

1. To avoid the risk of permanent damage to the transformer, the maximum current specified must not be exceeded.
2. The fidelity of the output waveform depends upon the maximum ampere-second rating not being exceeded.

MA391 IN POSITION ROUND CERAMIC THYRATRON

3582

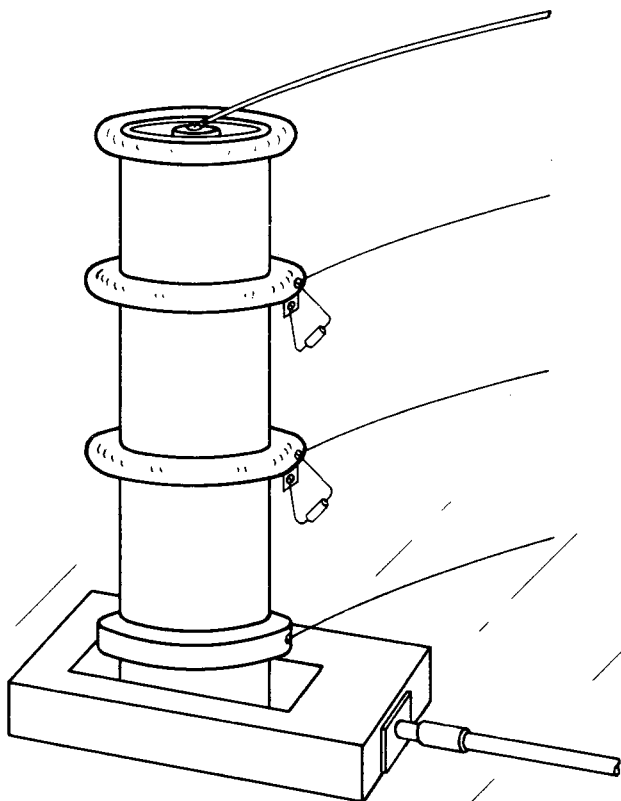

OUTLINE

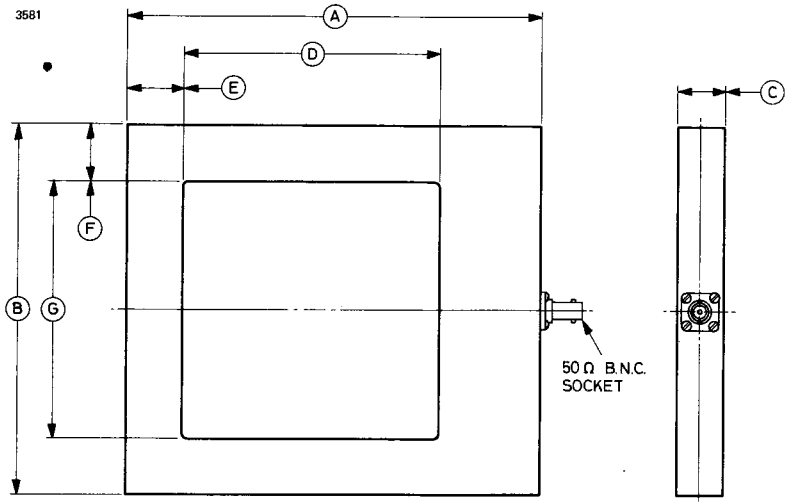

Ref	Inches	Millimetres
A	7.313 ± 0.125	185.8 ± 3.2
B	6.500 ± 0.125	165.1 ± 3.2
C	0.844 ± 0.031	21.44 ± 0.79
D	4.500 ± 0.062	114.3 ± 1.6
E	1.000 ± 0.062	25.40 ± 1.57
F	1.000 ± 0.062	25.40 ± 1.57
G	4.500 ± 0.062	114.3 ± 1.6

Millimetre dimensions have been derived from inches.

Whilst EEV has taken care to ensure the accuracy of the information contained herein it accepts no responsibility for the consequences of any use thereof and also reserves the right to change the specification of goods without notice. EEV accepts no liability beyond that set out in its standard conditions of sale in respect of infringement of third party patents arising from the use of tubes or other devices in accordance with information contained herein.



MA459

CURRENT PULSE MEASUREMENT TRANSFORMER

DESCRIPTION

The MA459 is a pulse current transformer intended for simple measurement and observation of current pulses through a thyatron or cable. The current flow is transformed to a voltage output suitable for display on an oscilloscope. Five current/voltage ratios are available (see table below).

The measurement or observation is carried out, for example, simply by removing the thyatron anode connection, placing the transformer over the tube and replacing the connection. The transformer can be allowed to rest wherever convenient but for safety reasons, its metal case must be at or near earth potential; it can be earthed via the outer screen of the signal cable. For accurate results, the case of the transformer must be isolated from the pulse circuit, and when used on a cable it should be supported so that the cable passes approximately through the centre of the transformer aperture. The output connection is a 50 ohm BNC socket and waveforms of a few nanoseconds duration can be observed.

The transformer is fully screened against electrostatic interference and is contained in a rugged cast aluminium housing.

The output matched load is contained within the transformer housing and the terminating impedance of the oscilloscope is non-critical within broad limits. However, if the oscilloscope input impedance is less than 5000 ohms the current calibration of the transformer will be affected although the waveform will not.

Trans- former type	Current for 1 V output (A)	Voltage for 1 kA input (V)	Maximum current (A) (see note 1)	Maximum amp-second rating (see note 2)	Maximum percentage droop (per μ s)
MA459	20	50	10 000	8×10^{-2}	2.0
MA459A	50	20	25 000	2×10^{-1}	0.8
MA459B	100	10	50 000	4×10^{-1}	0.4
MA459C	200	5	100 000	8×10^{-1}	0.3
MA459D	500	2	250 000	2.0	0.15

NOTES

1. To avoid the risk of permanent damage to the transformer, the maximum current specified must not be exceeded.
2. The fidelity of the output waveform depends upon the maximum ampere-second rating not being exceeded.

MA459 IN POSITION ROUND CERAMIC THYRATRON

3582

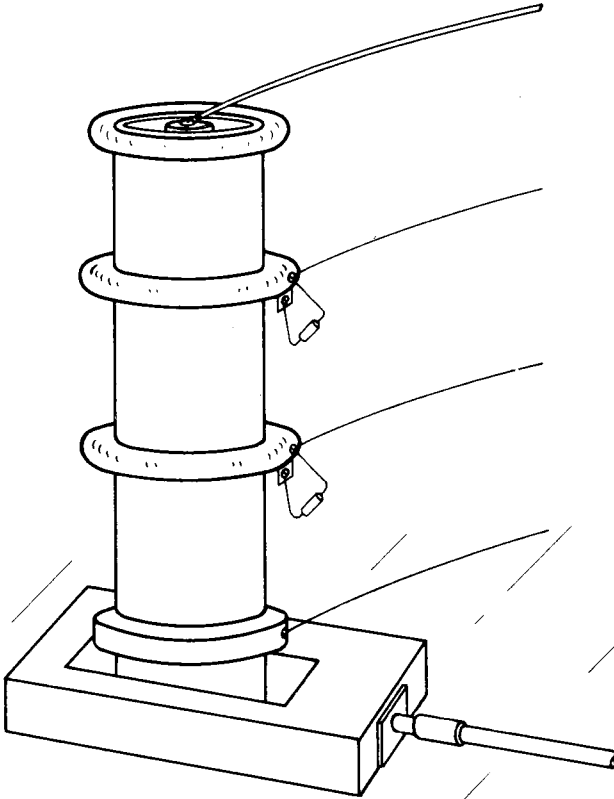

OUTLINE

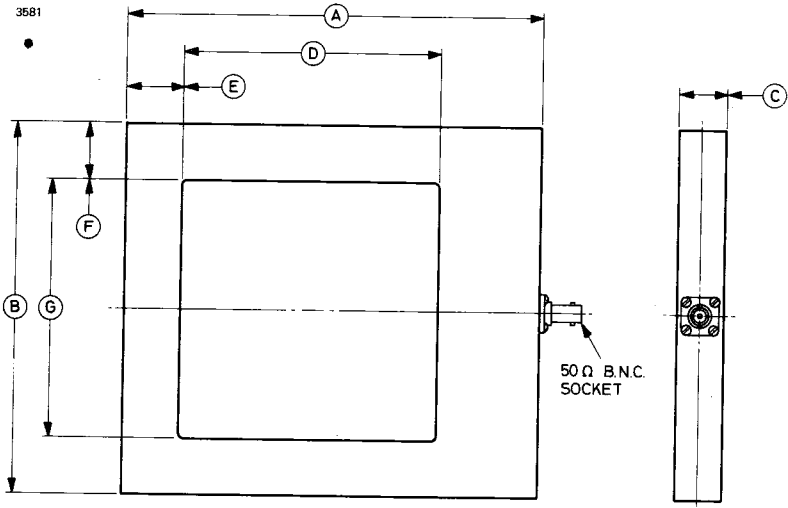

Ref	Inches	Millimetres
A	9.062 ± 0.125	230.2 ± 3.2
B	8.250 ± 0.125	209.6 ± 3.2
C	0.813 ± 0.031	20.65 ± 0.79
D	6.125 ± 0.062	155.6 ± 1.6
E	1.062 ± 0.062	26.97 ± 1.57
F	1.062 ± 0.062	26.97 ± 1.57
G	6.125 ± 0.062	155.6 ± 1.6

Millimetre dimensions have been derived from inches.

Whilst EEV has taken care to ensure the accuracy of the information contained herein it accepts no responsibility for the consequences of any use thereof and also reserves the right to change the specification of goods without notice. EEV accepts no liability beyond that set out in its standard conditions of sale in respect of infringement of third party patents arising from the use of tubes or other devices in accordance with information contained herein.

