

ENGLISH
ELECTRIC
VALVE
CO LTD



Product
Data

Tetrodes and Pentode

1970

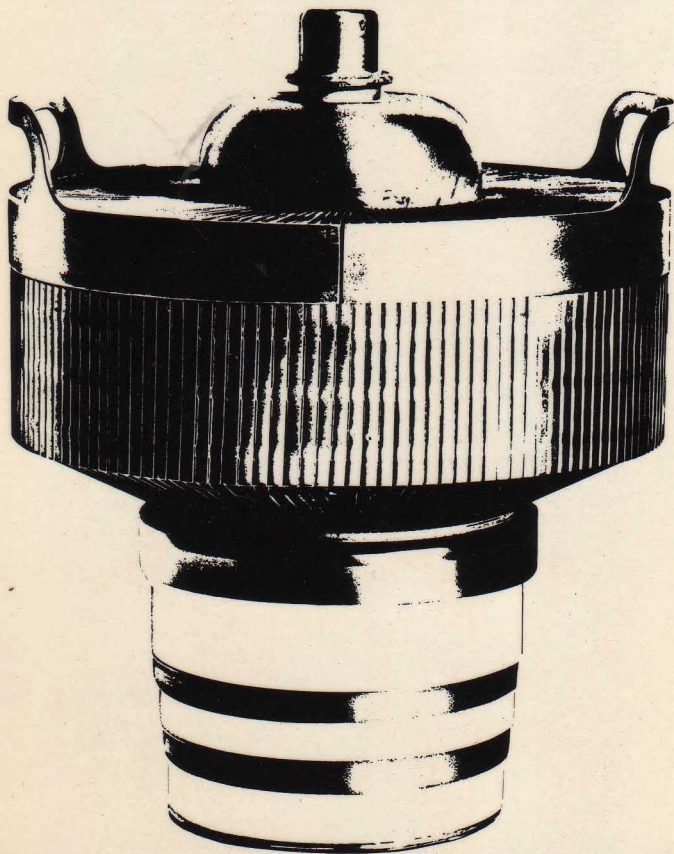

**TETRODES
PENTODE**

GENERAL SECTION



MEDIUM POWER TETRODES



HIGH POWER TETRODES



POWER PENTODE ,



The Valve Data Book comprises ten bound volumes, made up as follows:

- **IGNITRONS**
RECTIFIERS
INDUSTRIAL THYRATRONS
COLD CATHODE TUBES
- **TRIODES**
- **TETRODES AND PENTODE**
- **MODULATORS**
 Hydrogen Thyratrons
 Pulse Tetrodes
SPARK GAPS
- **MAGNETRONS**
- **AMPLIFIER KLYSTRONS**
- **OSCILLATOR KLYSTRONS**
TRAVELLING WAVE TUBES
BACKWARD WAVE OSCILLATORS
- **DUPLEXER DEVICES**
MONITOR DIODES
MICROWAVE SWITCHES
- **LIGHT CONVERSION DEVICES**
 Television Camera Tubes
 Storage Cathode Ray Tubes
 Laser and Flash Tubes
 Glow Modulators
- **VACUUM CAPACITORS**

These bound volumes replace the previous loose-leaf books and will be re-issued at intervals. When the most recent data are required for equipment design purposes, the individual sheets should be obtained.

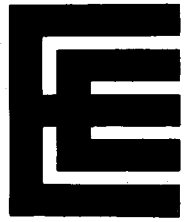

Tetrodes Pentode

English Electric Valve Company Limited

Chelmsford, Essex, England CM1 2QU

Telephone: Chelmsford (0245) 61777

Telex: 99103 Telegrams: Enelectico Chelmsford

July 1970



General Section



OVERSEAS REPRESENTATIVES and DISTRIBUTORS



Argentine Republic	English Electric Marconi Argentina S.R.L.	Buenos Aires
Australia	Amalgamated Wireless Valve Company Pty. Ltd.	Rydalmere, NSW
Austria	William Pattermann, Rudolfingasse 18	Vienna XIX
Belgium and Luxembourg	SAIT Electronics	Brussels
Brazil	Brazileira de Comercio Exterior Ltda. (BRASCOM)	Sao Paulo
Canada	English Electric Valve North America Ltd.	Rexdale, Ontario
China	Marconi (China) Ltd.	Hong Kong
Colombia	Representaciones y Promociones Industriales Ltda.	Bogota
Congolese Republic, Katanga and Ruanda	SAIT Electronics	Kinshasa, Congolese Republic
Denmark	Sophus Berendsen A/S	Copenhagen
Eastern Europe: Albania, Bulgaria Czechoslovakia German Democratic Republic, Hungary Poland, Rumania and Yugoslavia	Friedrich Bernhardt, Isoppgasse 23, Mauer, A-1238	Vienna XXIII, Austria

July 1970

Finland	Insinööritoimisto Oy Aseko Ab	Helsinki
France	Tranchant Electronique S.A.	Paris
German Federal Republic	Willy List, Franz-Rücker-Allee 42	6 Frankfurt-am-Main-90
Greece	Telectrotec	Athens
Iceland	Orka Ltd.	Reykjavik
India	Associated Instrument Manufacturers (India) Private Ltd.	Bombay, Calcutta, Madras and New Delhi
Iraq	Leon Kouyoumdjian and Co.	Baghdad
Italy	Marconi Italiana S.p.A.	Genoa, Milan and Rome
Japan	Cornes and Co. Ltd.	Osaka and Tokyo
Kuwait	Fager Development Est.	Kuwait
Malaysia	Associated Instrument Manufacturers (Malaya) Sdn. Berhad.	Kuala Lumpur, Penang and Ipoh
Mexico	Agencias Canadenses Y Occidentales S.A. (ACOSA)	Mexico 4, D.F.
Netherlands	SAIT Electronics Nederland	Rotterdam
New Zealand	Amalgamated Wireless (Australasia) N.Z. Ltd.	Auckland, Christchurch and Wellington
Norway	Norsk Marconikompani A/S	Oslo
Pakistan	International Industries Ltd.	Karachi, Lahore and Dacca
Peru	Fernando Ezeta B, Casilla 3061	Lima
Portugal	MEDITROM, Comercial de Equipamentos Técnicos S.A.R.L.	Lisbon

Singapore	Associated Instrument Manufacturers (Singapore) Sdn. Berhad.	Singapore
South Africa	Marconi (South Africa) Ltd.	Benoni
Spain	Europea de Electronica S.A. (Eurotronica S.A.)	Madrid
Sweden	Svenska Radio AB	Stockholm
Switzerland	Woods AG	Zurich
Syria	Attar Brothers Co. (Engineering)	Damascus
Thailand	Vichien Pathana Ltd. Partnership	Bangkok
Trinidad & Tobago, and Guyana	Telecomm Ltd.	Port-of-Spain, Trinidad
Turkey	Ratel Radio Telecommunication Co. Ltd.	Istanbul
United States of America	Camera Tubes: English Electric Valve North America Ltd., 1051 Clinton Street General Distributors: Calvert Electronics International Inc.	Buffalo, N.Y. New York
Uruguay	Pellmar S.A.	Montevideo
Venezuela	English Electric-Marconi de Venezuela C.A.	Caracas
Vietnam	International Group Ltd.	Saigon



EQUIVALENTS INDEX

Type to be replaced	EEV replacement	Type to be replaced	EEV replacement
2B52*	C1134	5CX1500A	5CX1500A
2B94*	C178A/5894	5D22*	C1112
4-125*	C1108	5D22/4-250A*	C1112
4-125A*	C1108	5F22*	C1112
4-250*	C1112	5F23A*	C1136
4-250A*	C1112	6F66R*	6166A/7007
4-250A/5D22*	C1112		CR192A
4-400A*	C1136	8F66R*	6166A/7007
4CV75 000A	CY1170J		CR192A
4CW10 000A	4CW10 000A	8T11R*	6166A/7007
4CX1000A	4CX1000A		CR192A
4CX1000K	4CX1000K	11E15	C1134
4CX1500B	4CX1500B	11E16	C178A/5894
4CX5000A	4CX5000A	13E1	C1158
4CX10 000D	4CX10 000D	55B/200A	C1134
4CX35 000C	4CX35 000C	55B/400A	C178A/5894
4D21*	C1108	5894*	C178A/5894
4D32	4D32	6155*	C1108
4F21*	C1108	6156*	C1112
4JC/201E	6166A/7007	6166*	6166A/7007
4JC/201S*	CR192A		CR192A
5B/900A	C1158	6166A	6166A/7007

* Near equivalent

			EEV replacement
		CR176	C1134
		CR176	C1136
		CR176	C1158
		CAS1	CAS1
		CR176	CR176
8168/4CX1000A	4CX1000A	CR192	CR192A
8170	4CX5000A	CR192A	CR192A
8170/4CX5000A	4CX5000A	CV2130	C1108
8171	4CX10 000D	CV2131	C1112
8171/4CX10 000D	4CX10 000D	CV2324	CR176
8349	4CX35 000C	CV2377*	C1158
8349/4CX35 000C	4CX35 000C	CV2797	C178A/5894
8352	4CX1000K	CV2799	C1134
8352/4CX1000K	4CX1000K	CV3543	4D32
8438	C1136	CV5959	C1136
8660	4CX1500B	CV6045	C1158
ACS5	4CX5000A	CV6184	4CX10 000D
AX4-125A/4D21*	C1108	CV8061	C1158
AX4-250A/5D22*	C1112	CV8067	C1134
AX9903*	C178A/5894	CV8244	CR192A
AX9903/5894*	C178A/5894	CV8295	4CX5000A
AX9910*	C1134	CV8699	4CX10 000D
C178A	C178A/5894	CV9918	4CX1000A
C178A/5894	C178A/5894	CV10819	C1134P
C1108	C1108	CV11106	5CX1500A
C1112	C1112	CV11107	4CX35 000C
C1123	4D32	CY1170J	CY1170J

* Near equivalent

Type to be replaced	EEV replacement	Type to be replaced	EEV replacement
CY1172	CY1172	QY4-250	C1112
E125A*	C1108	QY4-400	C1136
E250A*	C1112	RK4D32	4D32
E3033	4CX10 000D	RS685*	C1108
GL-4-250A/ 5D22*	C1112	RS686*	C1112
GL-4D21/ 4-125A*	C1108	RS1002A	C1136
GL-5894*	C178A/5894	RS1007*	C1108
ML-5894*	C178A/5894	RS1009*	C178A/5894
PL-4D21*	C1108	RS1019*	C1134
PL-5D22*	C1112	RS2002V	CY1172
Q160-1*	C1108	RS2793	4CX5000A
Q400-1*	C1112	SRS455*	C1108
Q450-1*	C1136	SRS456*	C1112
QB3/300	C1108	SRS4451*	C178A/5894
QB3.5/750	C1112	SRS4452	C1134
QB4-1100	C1136	TD25	C178A/5894
QQE03/20	C1134	TT16D	C1108
QQE06/40	C178A/5894	TT20	C1134
QQV03-20A	C1134	TT25*	C178A/5894
QQV06-40A	C178A/5894	WL-5D22*	C1112
QY3-125	C1108	YL1091	CY1172
		YL1460	C1136

* Near equivalent



TABULATED DATA

POWER TETRODES AND PENTODE

NATURAL COOLED TETRODES

EEV type	Anode dissipation max (W)	Output power (W) [⊕]	Anode voltage max (V)	Frequency (MHz) [‡]	Screen voltage max (V)
4D32	50	140	750	60	350
C178A/ 5894★	2 x 20	90◆	600	250/500	300
C1108	125	375	3000	120/200	400
C1112	250	1000	4000	75/120	600
C1134★	2 x 10	48◆	600	150/600	300
C1136	400	1100	4000	75/110	600
C1158▲	90	—	800	—	300

WATER COOLED TETRODE

EEV type	Anode dissipation max (kW)	Output power (kW) [⊕]	Anode voltage max (kV)	Frequency (MHz) [‡]	Screen voltage max (kV)
4CW10,000A	10	16	7.5	30/110	1.5

⊕ ‡ ★ ▲ ◆ See foot of page 2

FORCED-AIR COOLED TETRODES

EEV type	Anode dissipation max (kW)	Output power (kW) [⊕]	Anode voltage max (kV)	Frequency (MHz) [‡]	Screen voltage max (kV)
4CX1000A 4CX1000K	1.0	3.2■	3.0	110	0.4
4CX1500B	1.5	2.7■	3.0	30	0.4
4CX5000A	5.0	16	7.5	30/110	1.5
4CX10,000D	10	16	7.5	30/110	1.5
4CX35,000C	35	82	20	30	2.5
6166A	10	9.0	6.9	60/220	2.0
CR176	3.5	--	7.5	30	1.5
CR192A	10	9.0	6.9	60/220	2.0

VAPOUR COOLED TETRODES

CY1170J□	75	82	15	30	2.5
CY1172●	150	220	15	30	1.6

FORCED-AIR COOLED PENTODE

5CX1500A	1.5	3.2■	5.0	110	750
----------	-----	------	-----	-----	-----

⊕ Under class C unmodulated conditions

‡ Where two values are given, the lower value is the maximum frequency for full ratings. Derating is necessary for operation at the higher value

★ Double tetrode

▲ Series regulator; mutual conductance 35mA/V at $V_a = V_{g2} = 150V$, $I_a = 500mA$

◆ With 2 sections in push-pull

■ 2 valves, class AB₁ audio

□ Fitted with integral boiler unit

● Operates in boiler unit CY4120

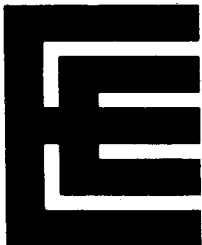

INTRODUCTION

The EEV range of power tetrodes extends from small double tetrodes with glass envelopes up to high power types of metal/ceramic construction, giving output powers up to 250kW.

Cooling methods vary according to anode dissipation; natural convection is adequate for the small types and forced-air, water or vapour cooling is employed for the higher power tubes.

Most types in the tetrode range employ thoriated tungsten filaments, but some smaller types have indirectly heated, oxide coated cathodes.

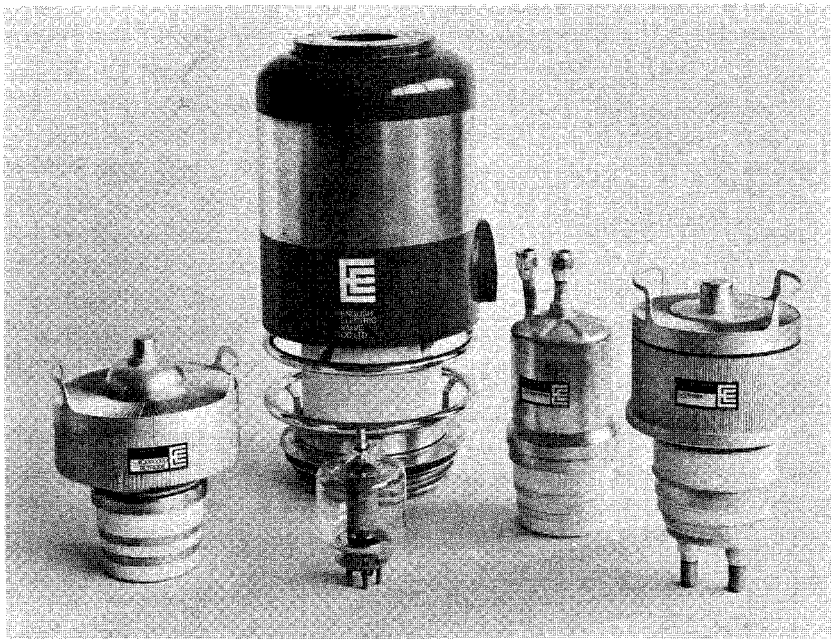

A selection from the range of EEV tetrodes

TETRODE CHARACTERISTICS

The electrical characteristics of a tetrode are usually specified by amplification factor and mutual conductance as defined below.

Amplification Factor

Tetrodes have two amplification factors.

- (a) The first gives a measure of the control effected on the anode current by the grid and anode voltages, with screen voltage as a constant. This is similar to the amplification factor of a triode and is defined by:

$$\mu = \left[\frac{\partial V_a}{\partial V_{g1}} \right] \quad V_{g2} \text{ and } I_a \text{ constant}$$

Normally, this amplification factor is very high as the anode voltage has little effect on the anode current.

- (b) The second measures the effect of the grid and screen voltages on the anode current, with anode voltage as a constant. It is defined by:

$$\mu_{g1g2} = \left[\frac{\partial V_{g2}}{\partial V_{g1}} \right] \quad V_a \text{ and } I_a \text{ constant}$$

This is known as the 'inner μ ' of a tetrode and is the constant specified in the data sheets for EEV tetrodes.

Mutual Conductance

Normally, the mutual conductance of a tetrode is defined by:

$$g_m = \left[\frac{\partial I_a}{\partial V_{g1}} \right] \quad V_a \text{ and } V_{g2} \text{ constant}$$

When mutual conductance is given in EEV data sheets for tetrodes it is measured in this manner.

Occasionally, the effect of control grid voltage on screen current is measured, this form of mutual conductance being defined by:

$$g_m = \left[\frac{\partial I_{g2}}{\partial V_{g1}} \right] \quad V_a \text{ and } V_{g2} \text{ constant}$$

COOLING METHODS

When a valve is operating, a proportion of the power fed into it is dissipated as heat within the valve. The filament power alone may amount to several kilowatts in the largest types, and to this must be added the dissipation at the grids and anode, and resistive losses wherever currents flow. The majority of this heat appears at the anode.

For dissipation levels up to approximately 1000W, the anode may be mounted within a glass envelope and cooled by radiation. The envelope of such a valve will be relatively large and will require at least unhindered air convection around it to prevent excessive glass temperatures. Some valves of this type may have higher ratings which can be used if forced-air cooling is applied to the envelope.

Valves operating at higher power levels, and certain lower power types with small overall dimensions, are designed with the anode forming part of the external vacuum envelope. This permits direct cooling of the anode by forced-air, water or vapour.

In addition to anode cooling, it may be necessary to provide local air cooling for the areas where filament and grid terminals are sealed into the envelope; a small blower is required for this purpose.

The cooling requirements specified in data sheets are minimum values and it is good practice to provide generous margins in all cooling systems. The operation of valves with less than the minimum recommended cooling is likely to lead to reduced valve life and, in extreme cases, can cause early failure due to overheating. Many of the larger valves require cooling to be continued for a minimum time after switching off power to the valve.

Data sheets give maximum permissible temperatures for the bulb and seals of large valves, and these should be checked with thermocouples or temperature sensitive paint during development of new equipments.

Forced-air Cooling

The anodes of valves intended for forced-air cooling are provided with finned radiators through which air is blown. In a typical installation the valve is mounted anode down, seated in an insulator tube through which air is drawn downwards. The alternative is to blow air upwards through the radiator, but this has the disadvantage that hot air is blown into the equipment and may cause other components to overheat.

Characteristic curves are published giving the airflow required for various values of anode plus grid dissipation and inlet temperature. Other curves give

the air pressure across the radiator at various flow rates. These are primarily for use in the initial choice of a fan or blower, and should not be used uncorrected for making exact measurements of anode dissipation (see page 11). In deciding upon the required fan output it is necessary to take into account pressure drops in the system additional to that across the valve radiator. These include losses in the air ducting, bends and sudden changes in cross section. These problems are discussed by A. G. Nekut (Ref. 1) and W. E. Pannett (Ref. 2).

The valve must be insulated from the vibration of the blower; this may be achieved with a length of flexible ducting, or a short break in a rigid duct, but either method will introduce some losses.

The pressure across the radiator may be checked by the use of a water manometer connected into the air duct close to the radiator on the fan or blower side. If the valve is run under dead loss conditions, i.e. not oscillating and without grid current, then all the input power appears as heat and if the temperatures of air entering and leaving the radiator are measured, the airflow can be calculated from:

$$\text{airflow in ft}^3/\text{min} = \frac{T_{in} \times (\text{anode} + \text{screen} + \text{filament dissipation in W})}{164 \times (\text{temperature rise across radiator in } ^\circ\text{C})}$$

where T_{in} = absolute temperature of inlet air in $^\circ\text{K}$.

The airflow-pressure characteristic can thus be corrected and the manometer may then be used as an airflow monitor provided it is recalibrated from time to time, since dirt in the airstream may clog the radiator passages.

It must be understood that the flow rates given in data sheets apply to sea-level pressures. The cooling effect is proportional to the temperature rise across the radiator and the mass flow rate of air, so that operation in a less dense atmosphere at high altitude will call for higher volumetric flow rates. The performance of the blower will also vary with altitude and the blower manufacturer should be consulted for information on this point.

The air density at a given pressure and ambient temperature can be calculated from:

$$\text{density in lb/ft}^3 = \frac{0.737 \times \text{pressure in inches of mercury}}{\text{absolute temperature in } ^\circ\text{K}}$$

Unless the air in the inlet region is particularly dust-free, filtering will be necessary to prevent blocking of the radiator. The inlet air should also be free of corrosive fumes such as exhaust gases.

Interlocks The anode, screen and filament supplies should be fitted with cut-outs to prevent application of power until the airflow is established, and to

- remove all power immediately if any of the following conditions should occur:
- a) radiator airflow less than minimum – to be sensed by a vane in the air-stream between blower and radiator.
 - b) excessive inlet air temperature
 - c) failure of the blower motor, or of the filament terminals blower if fitted.

Water Cooling

Water cooling is normally applied to the anode only, a small air blower usually being required for the filament terminals. Two distinct types of water cooling jacket may be used:

- 1) an integral water jacket, which may be either a continuous tube soldered to the outer surface of the anode, or a light concentric enclosure fitted to the valve during manufacture. These types carry pipe unions for water connection and valve replacement is almost as simple as for air-cooled types.
- 2) a separate water jacket, which is normally a casting and forms a permanent part of the cooling installation. The valve is retained in the jacket by clamps, with flexible sealing rings to prevent water loss. This method can give the lowest possible cost for spare valves but replacement takes a little longer than with other methods.

The cast jacket and the spun integral jacket have helical ridges on the inner surface, so that the water flow follows a helical course around the anode from the bottom to the top of the jacket. The inlet must be at the bottom to prevent air pockets developing within the jacket; the coiled-tube type of integral jacket is not affected in this way and can use either direction of flow.

Water Connections The water jacket is necessarily at anode voltage, so that in addition to an insulated mounting it is necessary to use insulating hose connections, long enough to reduce leakage currents through the water to acceptable levels. A length of 1 metre per kV anode voltage is normally adequate but if shorter hoses are used the electrolytic corrosion caused by leakage currents may become significant. The leakage current is a function of pipe length, pipe bore and water conductivity. If very pure water is used the insulating pipe lengths can be considerably reduced.

Water Purity The water used in the cooling system should have a resistivity of at least $3.3\text{k}\Omega\text{-cm}$, an inorganic solids content less than 30 parts per million and a low dissolved oxygen content. If water of low resistivity is used,

considerable corrosion and scaling must be expected; the resistivity should preferably exceed 10kΩ-cm. If an ample supply of soft water meeting these conditions is available, this may be used but most installations consist of a closed circuit cooling system filled with distilled or demineralized water. The use of water not meeting the purity standards given will result in excessive scale formation on the valve anode, and possibly other components, and may result in early valve failure.

The closed circuit system requires a continuously operating pump, a reservoir and heat exchanger; it may be possible for a number of valves to share some of these components provided that the flow rate and temperature at each valve are individually monitored.

Flow Rate The flow rate, temperature rise and dissipation are related by the following expression:

$$\text{flow in litres/minute} = \frac{15 \times (\text{anode} + \text{screen} + \text{filament dissipation in kW})}{\text{temperature rise across jacket in } ^\circ\text{C}}$$

this can be used as a calibration check when an installation is tested.

Interlocks The anode, screen and filament supplies should be fitted with cut-outs to prevent application of power until the water flow is established, and to remove power immediately if any of the following conditions should occur:

- a) water flow less than minimum
- b) excessive water outlet temperature
- c) failure of the filament terminals blower if fitted.

Vapour Cooling The vapour cooling system uses the latent heat of boiling water to remove heat from the valve anode. A valve designed for vapour cooling has a thick-walled copper anode block with vertical cooling passages. The anode is immersed in water in a container referred to as the boiler and the water in the cooling passages boils, generating steam in proportion to the anode dissipation. There are two main types of system for condensing the steam generated:

- 1) an internal condenser, consisting of a coiled tube through which cooling water flows from an external source (see Fig. 1). The quantity of cooling water required is very much less than would be needed for a water-cooled valve of the same power, and the system is so simple and compact that double boiler-condenser units are made to hold two valves.

This type of boiler is sealed to prevent steam loss, and normally operates at slightly above atmospheric pressure. A cut-out is fitted to switch off the valve if the water level falls or if internal pressure becomes excessive.

2) a separate condenser; there are two variants of this type of boiler:

- a) upward steam exit (see Fig. 2). This is the usual type and has the advantage that it operates by natural convection, so that it has almost no moving parts. It is quiet in operation and extremely reliable.

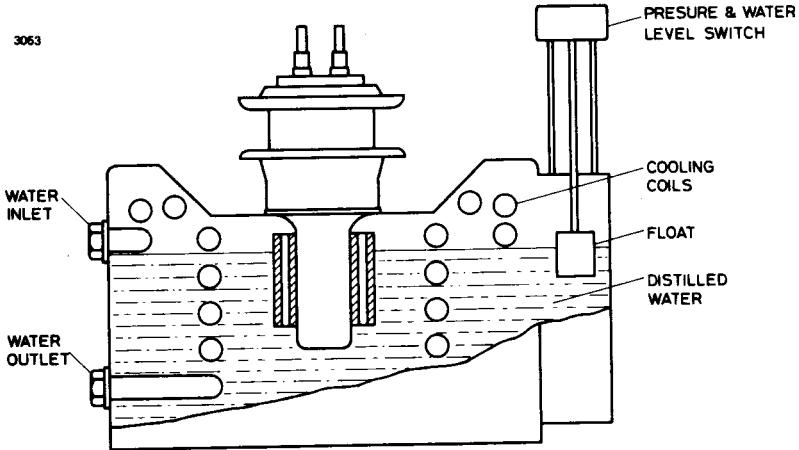

Fig. 1. Integral boiler-condenser unit

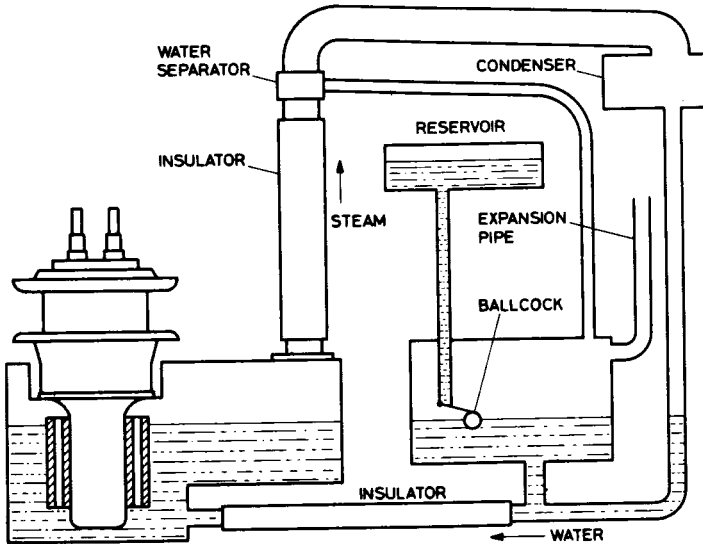

Fig. 2. Upward steam exit to separate condenser

b) downward steam exit (see Fig. 3). This is sometimes found to give a more convenient layout of components, and it may be preferred for high frequency applications, but it requires the use of a low pressure circulating pump. The pump feeds an excess of water to the boiler, so that the water level is maintained at the top of the internal weir. One advantage of this system is that the presence of the weir makes it possible to use a single condenser for any number of valves mounted at different levels.

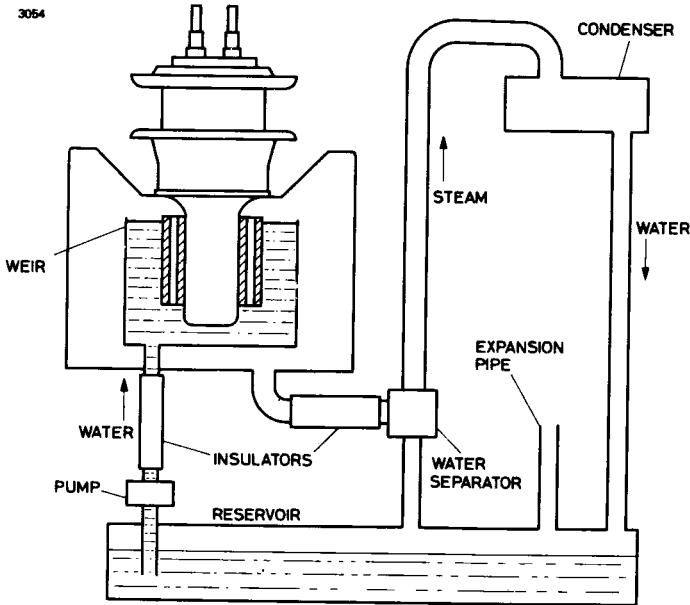

Fig. 3. Downward steam exit to separate condenser

Both types of separate condenser system are vented to atmospheric pressure at a point where steam will not be lost.

Distilled or demineralized water must be used in all types of boiler but the total quantity needed is not large and only occasional topping up should be necessary. The boiler units are at anode voltage and insulating pipes are again required for water connections. Any convenient supply of clean water may be used for the internal condenser.

Choice of Cooling Method

In deciding between the alternative methods of cooling, several points must be considered.

Water cooled valves are less costly than their air cooled counterparts but their running costs may be higher unless there is a cheap supply of clean water available. The necessity for de-scaling must be borne in mind unless a closed circulating system is employed. Using a mains water supply, the valve and its water cooling equipment should take less space than a similar air-cooled installation.

Forced-air cooled valves require no external supplies for cooling. The whole method is cleaner, though it may require more space. Noise from the blower could be a deciding factor in some locations. Air filters will be necessary in dirty atmospheres, and frequent periodic cleaning will be essential under extreme conditions.

Vapour cooling is able to handle very high powers, and in some cases a vapour cooled valve has higher ratings than air or water cooled versions of the same basic type. Coupled with this is high overload capacity, which is particularly valuable for industrial oscillators. Noise, maintenance and running costs are reduced to a minimum and valve replacement is quicker than with water cooled types.

OPERATING NOTES

Characteristics

The published curves and characteristics are typical values and represent the average figures derived from measurements on a number of valves.

Filament Supplies

Modern high power tetrodes use thoriated tungsten filaments, which must always be operated at the correct temperature for optimum life and performance. The filament voltage should be maintained as close as possible to the value given in the data sheet; deviations from this value should never exceed $\pm 5\%$ and still closer control to within $\pm 1\%$ is advisable.

Certain valve types having pure tungsten filaments are still in use and for these the optimum filament voltage varies with the peak cathode current required. In general, reducing the filament voltage will give increased life provided that the available emission is still high enough for the particular operating conditions. Each valve is marked with the filament voltage required to give the rated maximum cathode current at 90% saturation and details of the voltage reduction appropriate to lower currents are given in the data.

Measurements of filament voltage must always be made at the filament terminals of the valve, since significant voltage drops can occur in flexible leads and connectors. If the waveform is not sinusoidal it is essential to measure the true r.m.s. value.

In addition to accurate voltage control, the filament supply must, in most cases, incorporate a means of limiting the surge current drawn by a cold filament on starting. The valve data sheets include a maximum rating for the surge current and a typical value for the cold resistance of the filament. The necessary current limiting may be achieved by a resistance in the filament transformer primary circuit, shorted out by a delay switch. Alternative methods include a transformer with high leakage reactance and the use of a fully variable transformer, manually controlled. An additional facility often used with pure tungsten filaments is voltage reduction during standby operation; a reduction of 20% during short periods is typical.

For optimum life with types having oxide coated cathodes, the heater voltage must not vary by more than 2½% from the nominal value; temporary fluctuations must not exceed $\pm 10\%$.

Cathode Current

The total cathode current is the sum of the anode, screen and grid currents; for most valves maximum ratings are quoted for both the mean anode current and the peak usable cathode current. The peak usable cathode current is determined by the emission capability of the cathode and if this rating is exceeded in service the cathode life will be reduced.

Grid Parameters

Grid Voltage When valves are to be used in parallel or push-pull circuits, each valve should have a separate grid resistor. Even if the valves are closely matched when new, unequal sharing of the load is certain to occur during life unless the grid bias can be individually adjusted. If this is not done the anode current rating should be reduced by 10%.

Grid Current The grid current values and ratings given in data sheets are as measured with a meter in the grid lead; the valve user is not required to make allowance for the effect of secondary emission by the grid. The actual value of grid current may vary appreciably between valves of the same type; this is not important provided the maximum rating is observed.

Grid Driving Power The driving power is the sum of the powers dissipated in the grid and the bias source.

The grid driving power may be taken as approximately the product of the

peak value of the exciting grid voltage and the d.c. grid current. The peak value of the exciting grid voltage may be calculated as the sum of the bias voltage and the peak positive voltage swing, which may be measured with a peak-reading valve voltmeter. The effective driving power may be greater than the calculated value as a result of tolerances in valve characteristics, electron transit-time losses and other factors.

Screen Dissipation

With no alternating voltage applied to the screen, the screen dissipation is the product of screen voltage and current. Screen dissipation may become excessive if the anode voltage is removed; suitable protective devices must be included to limit screen dissipation in the event of anode circuit failure.

Anode Voltage

The anode voltage is normally supplied by a multiphase rectifier with some form of voltage regulation. For broadcast amplifiers smoothing filters will be required but in most other cases the ripple content of a 3-phase full wave or equivalent rectifier is acceptable.

Anode Dissipation

The anode dissipation is the difference between the anode input power and the output power. For water or forced-air cooled valves the anode dissipation can be determined from the temperature rise and flow rate of the coolant.

Output Power

The output power can be measured at several places, the lowest value appearing at the ultimate load. The value given in a data sheet is the total r.f. power developed in the anode circuit. For an oscillator:

$$P_{\text{load}} = \eta_a(P_{\text{out}} - P_{\text{drive}})$$

where P_{load} = power delivered to load

P_{out} = output power of valve to anode circuit

P_{drive} = drive power fed back to grid circuit

and η_a = anode circuit efficiency.

For an amplifier, the term P_{drive} is zero, since the grid drive power is not derived from the anode circuit.

Efficiency

The efficiency is the ratio of the output power of a valve to the d.c. input power. The values given in data sheets are derived from calculations of typical operating conditions.

Valve Life

Early catastrophic failure is unusual in large tetrodes but may result from exceeding the ratings, or mechanical shocks or impact. Most of these valves exhibit a gradual loss of cathode emission towards the end of their life and this eventually results in the output power falling below the required level.

The ratings of each valve type are chosen to give a long operating life, but in all cases the life expectancy can be considerably increased by operating at reduced anode current levels. For pure tungsten filament types it is necessary to reduce the filament voltage accordingly.

Protection Devices

It is most important that large power valves are adequately protected against the failure of associated components and incorrect operating conditions.

Cooling systems in particular must be interlocked so that no voltages can be applied to the valve unless all cooling supplies are operating correctly. The filament power of large valves is sufficient to damage the valve in the absence of normal anode cooling, so that both h.t. and filament supplies must be cut off if the cooling fails. The nature of the safety devices depends on the cooling method involved; for air cooling the flow rate is the essential factor and the air outlet temperature can also be checked. Similarly for water cooled anodes the flow rate and outlet temperature should be interlocked while with vapour cooling there will be water level and steam pressure trips. In some cases it is also advisable to have a direct check on the valve temperature, and some of the larger EEV types are fitted with thermal fuses for this purpose.

Abnormal load conditions, or the failure of associated circuit components, may result in valve failure due to excessive current or dissipation in the grid, screen or anode. Interlocks should remove h.t. supplies if the anode, screen or grid currents exceed the maximum ratings. In many cases the anode dissipation will be excessive if the grid bias is insufficient and an interlock which operates if the grid current falls below a minimum value will give protection against this hazard.

MAXIMUM RATINGS

Unless otherwise stated all the maximum ratings in the data are absolute ratings. This means that the equipment designer is responsible for ensuring that they are not exceeded, even momentarily, under any conditions of mains fluctuations, surges or component tolerances. See British Standard Code of Practice CP 1005: 1962 'The Use of Electronic Valves'.

Maximum Anode Voltage

In most cases this is an absolute rating, but valves intended for industrial use may be given a nominal rating which allows for normal mains voltage fluctuations and component tolerances in the equipment.

Current Ratings

The maximum anode and screen current ratings apply to the mean values of current. Where a maximum grid current rating is given this also applies to the mean value, as measured by a normal mean-reading meter.

The peak usable cathode current is the highest peak cathode current (i.e. the sum of the peak anode, screen and grid currents) which may be used. Currents in excess of this figure will seriously curtail life even though the electrode dissipations may be within their limits.

Maximum Anode Dissipation

This is the maximum permissible steady anode dissipation. Due to the large thermal capacity of the anode, valves having dissipation ratings above 1kW may dissipate higher powers for periods up to 15 seconds. The permissible anode dissipation specified is ample for normal use and is not usually the limiting factor.

Maximum Grid Dissipation

This is the maximum grid dissipation which may be used. If this value is exceeded the grid structure may become distorted and change the characteristics of the valve. In addition to this effect, evolution of gas and the onset of grid emission may shorten the operating life.

Maximum Screen Voltage

Where it is necessary to employ the maximum screen voltage then either a regulated supply must be employed or the screen voltage must be lower than the maximum by a margin sufficient to cover mains voltage fluctuations, regulation etc. In general it will be found that typical operating conditions involve a screen voltage well below the maximum.

Maximum Screen Input

This is the maximum permissible screen input power. Since the whole of this power is dissipated in heating the screen, similar remarks to those above for maximum grid dissipation will apply. It should be noted that grid and screen structures generally have low thermal capacities and therefore, overloads of very short duration may be enough to cause permanent damage.

Maximum Frequency

The ratings for each valve include a maximum frequency, above which the other ratings must be reduced. In some cases information on the reduction required is given and for other types, English Electric Valve Company Ltd. should be consulted if operation at higher frequencies is intended.

Derating for Different Operating Conditions

When the data sheet for a valve gives ratings only for class C unmodulated operation and it is required to use a different class of operation, English Electric Valve Company Ltd. should be consulted. For preliminary design purposes, the derating factors in the following table may be used as a guide.

Operating condition	Anode voltage	Anode current	Input power	Anode dissipation	Grid current
Class C telegraphy	1	1	1	1	1
Anode modulation	0.8	0.833	0.67	0.67	1
Class B r.f.	1	0.833	0.833	1	1
Class A or B audio amplifier	1	1	1	1	1

CALCULATION OF OPERATING CONDITIONS

In the curves normally employed for depicting valve characteristics the various electrode currents are plotted against anode voltage or grid voltage. Such curves do not lend themselves readily to the graphical determination of the operating conditions of oscillators or amplifiers biased beyond anode current cut-off, since the operating line then takes the form shown in Fig. 4. In order to facilitate calculations, the data sheets for EEV tetrodes usually include constant current curves on which the operating line is straight.

Various authors, including Sarbacher (Ref. 3), have dealt with methods of using this operating line as a basis from which the performance of oscillators or class C amplifiers can be obtained by graphical means. The EEV Calculator for oscillators and class C amplifiers presents the results of such work in a form most likely to be useful to equipment designers and others. The calculator is supplied in a separate envelope, together with blank design sheets and instructions for use.

Selection of an Operating Line

This is likely to be a process of successive approximation since, although the cut-off end of the line may be decided quite easily, the peak anode current end may require several test calculations to be carried out before the optimum position is selected.

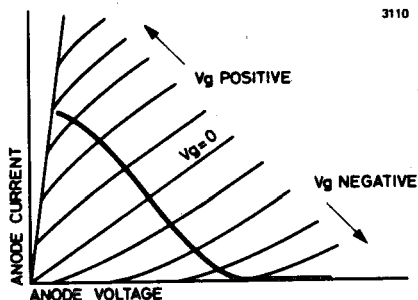

Fig. 4. Typical I_a - V_a characteristics with operating line

D.C. Grid Bias The anode supply voltage and screen voltage are decided first, then the corresponding grid cut-off voltage can be found from the curves. For most class C applications, best results are obtained with a bias voltage 1.6 to 2 times the cut-off voltage. The values selected for anode voltage and grid bias fix one end of the operating line.

Peak Anode Current A good method of determining the peak anode current is as follows:

- (a) Assume a reasonable efficiency, say 75% for an oscillator. This means that three quarters of the input power becomes output power leaving one quarter to be dissipated in heat at the valve anode. Thus,
- (b) Input power = 4 x rated anode dissipation.
- (c) D.C. anode current $I_a = \frac{\text{Input power}}{V_a}$

I_a must not exceed the maximum anode current rating.

- (d) The ratio of peak to d.c. anode current is of the order of 3.5 to 4.5 depending upon the angle of flow adopted and upon the law obeyed by the anode current. It is a good starting point to assume that:

$$\text{Peak anode current} = 4 \times I_a$$

Minimum Anode Voltage The value of peak anode current defines a locus on which the end of the operating line will lie. The actual position is given approximately by two further considerations:

- a) the minimum anode voltage should usually be 10 to 15% of the d.c. anode supply voltage.
- b) the peak positive grid voltage should be minimized, for a low grid current.

D.C. Anode Current Having drawn an operating line, the anode current can be calculated, using the design sheet and calculator. The result may differ appreciably from the previously assumed value and if it is not satisfactory another test calculation is carried out with a different minimum anode voltage. It may be necessary, if variations in minimum anode voltage do not give the desired result, to modify the assumed value of peak anode current. When the operating line appears to be satisfactory, the formulae given with the calculator may be used to determine the other parameters, which must be compared with maximum ratings where appropriate.

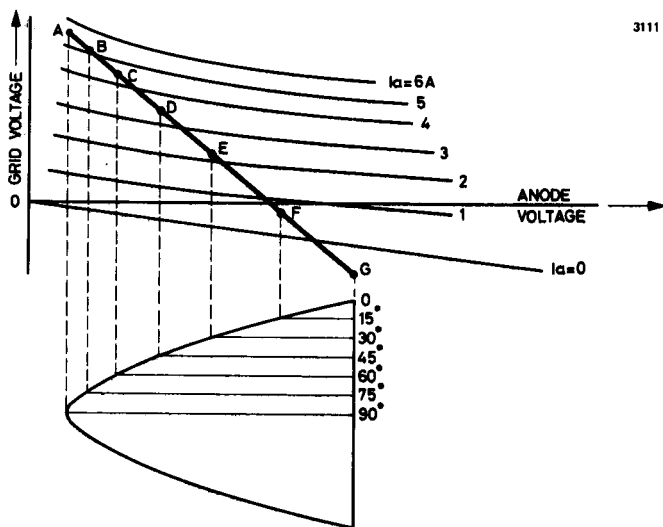

Fig. 5. Typical constant current characteristics with operating line

How the EEV Calculator Works

If the operating line AG of an oscillator or class C amplifier is drawn on the constant current characteristics of the valve to be used (see Fig. 5) then any

point on this line will give the conditions prevailing in the circuit at that instant in the electrical cycle. That is to say the instantaneous currents in each electrode and the instantaneous values of the grid and anode voltages can be read off the curves at that point. If several such points A, B, C, D, E and F are considered, corresponding to 15° intervals in the electrical cycle, then it has been shown that by taking the instantaneous currents at these points and using them in the following formulae, the average or d.c. current over the whole cycle and the peak value of the fundamental current are readily obtained:

$$\text{D.C. current} = 1/12(0.5A + B + C + D + E + F)$$

$$\text{Peak fundamental} = 1/12(A + 1.93B + 1.73C + 1.41D + E + 0.52F)$$

The EEV Calculator is a simple device which enables the required values to be read off the curves without constructing the 15° intervals by hand. The design sheets supplied with it are arranged so that the current values and calculations can be written in logical sequence.

STORAGE, INSTALLATION AND MAINTENANCE

Storage

Valves should be stored in their original packing, or in suitable racks designed to protect the valves from excessive shock or vibration and to ensure that no stresses are imposed on the envelope or seals. When valves are stored in racks they should be vertical, with filament terminals up.

Stored valves must not be subjected to extremes of temperature; the ambient temperature should be maintained within the range 0 to $+35^\circ\text{C}$. Valves must be shielded from draughts and strong sunlight, and must not be stored near volatile materials, acids etc. which might have harmful effects.

The external glass or ceramic envelopes of valves stored in racks should be shielded from dust and grit with plastic or fabric covers, or should be cleaned periodically. Care must be taken when cleaning to avoid scratching glass surfaces, or making permanent marks on ceramic parts.

Cold Filament Resistance This can be checked on delivery as a simple test for filament damage in transit. Most transmitting valves are accompanied by a card giving the value of cold filament resistance, measured with a Kelvin bridge at a relatively low filament current (0.1A or 1A). Fracture of a filament strand will increase the resistance by a proportion which depends on the number of parallel paths in the filament and for most types is 5% or more.

Installation

It is particularly important that large valves should be mounted accurately vertical; in general this will be determined by the construction of the equipment in which the valve is fitted and there may be no provision for adjustment, so this point should be checked when the equipment is first installed.

Once a valve is removed from its original packing, it must be handled carefully, to avoid mechanical damage to the envelope or the internal structure. When a valve is transferred from rack to bench, or fitted into an equipment, it must not be knocked on solid projections; tools must be used with care in the vicinity of the valve.

Water or vapour cooled valves are supplied with new sealing rings which should be used to replace the old ones.

Valves operating at high voltage will produce strong electric fields near the envelope, and when operating at r.f. there may be strong electro-magnetic fields not only around tuned circuits but in the general region of the valve. In general, the amount of material in these areas should be kept to a minimum; especially to be avoided are sharp edged conductors which might promote corona discharges, and closed conducting circuits which will dissipate power and reduce the efficiency. Where flexible leads are used for filament and grid connections, they should not have sharp bends, especially near the valve.

Conditioning Each valve is tested immediately before delivery, and if the subsequent storage period does not exceed 2 years it may be run at full power when first installed. Valves which have been stored longer than 2 years should be run for 15 minutes with filament power only. before applying anode power; all cooling supplies must be on while the filament is energized. Where a valve has been stored for more than four years it should be run for 30 minutes on filament power only. If the valve brings out the h.t. trips on application of full voltage, the voltage should be reduced to approximately 60% and the valve run for 15 minutes before re-application of full voltage.

Maintenance

Maintenance of the valve itself consists of occasional cleaning of the envelope and terminals; under good environmental conditions even this may not be necessary. For water or forced-air cooled types, regular attention to the cooling system may be required; radiators and water jackets may need cleaning, according to the impurity content of the air or water used.

The filaments of large valves tend to become more brittle with age, and after a few thousand hours life a valve should not be disturbed unnecessarily.

REFERENCES

Mentioned in the text

1. A. G. Nekut. 'Blower selection for forced-air cooled tubes'. **Electronics**, August 1950, p. 88.
2. W. E. Pannett. 'Radio Installations. Their design and maintenance', Chapman & Hall, 1951.
3. R. I. Sarbacher. 'Graphical determination of power amplifier performance'. **Electronics**, Vol. 15, December 1942, p. 52.

Further References

4. E. E. Spitzer. 'Principles of the electrical rating of high-vacuum power tubes'. **Proc. I.R.E.**, Vol. 39, No. 3, April 1951, p. 60.
5. H. P. Thomas. 'Determination of grid driving power in radio frequency power amplifiers'. **Proc. I.R.E.**, Vol. 21, No. 8, August 1933, p. 1134.
6. W. G. Wagener. 'Simplified methods for computing performance of transmitting tubes'. **Proc. I.R.E.**, Vol. 25, January 1937, p. 47. Analysis of current pulses and performance calculations without using constant current curves.
7. F. E. Terman. 'Radio Engineers' Handbook', McGraw-Hill, 1943.
8. F. E. Terman and W. C. Roake. 'Calculation and design of Class C amplifiers'. **Proc. I.R.E.**, Vol. 24, 1956, p. 620.
9. H. J. Scott. 'A note on Class C power amplifier design'. **Proc. I.R.E.**, Vol. 40, October 1952, p. 1250.
10. L. T. Apps. 'Class C amplifier and oscillator design . . . a simplified method'. **Electronic Engineering**, Vol. 27, January 1955, p. 30.
11. E. May. 'Industrial High Frequency Electric Power'. Chapman & Hall, 1949.
12. M. T. Elvy. 'Electronic heating and the woodworking industry'. **Journal British I.R.E.**, Vol. 14, No. 11, November 1954, p. 547. This article gives a very extensive bibliography on the subject of dielectric heating.



Medium Power Tetrodes



R.F. POWER TETRODE

Service Type CV3543

The data should be read in conjunction with the Power Tetrode Preamble.

ABRIDGED DATA

Beam power transmitting tetrode

Anode dissipation	50	W max
Anode voltage	750	V max
Frequency for full ratings	60	MHz max
Output power (class C unmodulated)	140	W

GENERAL

Electrical

Cathode	indirectly heated, oxide coated	
Heater voltage	6.3	V
Heater current	3.75	A
Peak usable cathode current	2	A
Grid-screen amplification factor	10	
Inter-electrode capacitances:		
input	26	pF
output	13	pF
grid to anode	0.4	pF max

Mechanical

Overall length	5.750 inches (146mm) max
Overall diameter	2.312 inches (58.7mm) max
Net weight	6 ounces (170g) approx
Mounting position	any
Base	B.S.448-B7A

Cooling natural

ANODE AND SCREEN MODULATED R.F. POWER AMPLIFIER

(Class C telephony, carrier conditions per valve for use with a maximum modulation factor of 1.0)

MAXIMUM RATINGS (Absolute values)

Anode voltage	600	V max
Screen voltage	350	V max
Grid voltage	-200	V max
Anode current	300	mA max
Grid current	15	mA max
Anode dissipation	50	W max
Screen dissipation	10	W max
Grid dissipation	0.75	W max
Frequency (for full ratings)	60	MHz max

TYPICAL OPERATING CONDITIONS

Anode voltage	600	V
Screen series resistor	10 000	Ω
Grid voltage	-100	V
Anode current	220	mA
Screen current (approx)	28	mA
Grid current (approx)	10	mA
Driving power (approx)	1.25	W
Output power (approx)	100	W

R.F. POWER AMPLIFIER AND OSCILLATOR

(Class C telegraphy, key-down conditions, one valve)

MAXIMUM RATINGS (Absolute values)

Anode voltage	750	V max
Screen voltage	350	V max
Grid voltage	-200	V max
Anode current	300	mA max
Grid current	15	mA max
Anode dissipation	50	W max
Screen dissipation	14	W max
Grid dissipation	0.75	W max
Frequency (for full ratings)	60	MHz max

TYPICAL OPERATING CONDITIONS

Anode voltage	750	V
Screen voltage	300	V
Grid voltage	-100	V
Anode current	250	mA
Screen current (approx)	34	mA
Grid current (approx)	12	mA
Anode dissipation	47	W
Screen dissipation	10	W
Peak r.f. voltage	119	V
Driving power (approx)	1.5	W
Output power	140	W
Efficiency	75	%

AUDIO FREQUENCY POWER AMPLIFIER (Class AB₁ and AB₂)

TYPICAL OPERATING CONDITIONS

(Values are for 2 valves in push-pull unless otherwise stated)

Anode voltage	600	600	V
Grid voltage	-37.5	-25	V
Screen voltage	350	250	V
Peak a.f. input voltage (grid to grid)	74	70	V
Maximum-signal anode current	350	365	mA
Zero-signal anode current	100	100	mA
Maximum-signal screen current	46	26	mA
Effective load (anode to anode)	3000	3000	Ω
Driving power (maximum-signal, approx)	0	0.45	W
Output power (maximum-signal, approx)	112	125	W
Anode dissipation (per valve, approx)	49	47	W
Screen dissipation (per valve, approx)	8	3	W

TYPICAL ANODE AND SCREEN CHARACTERISTICS

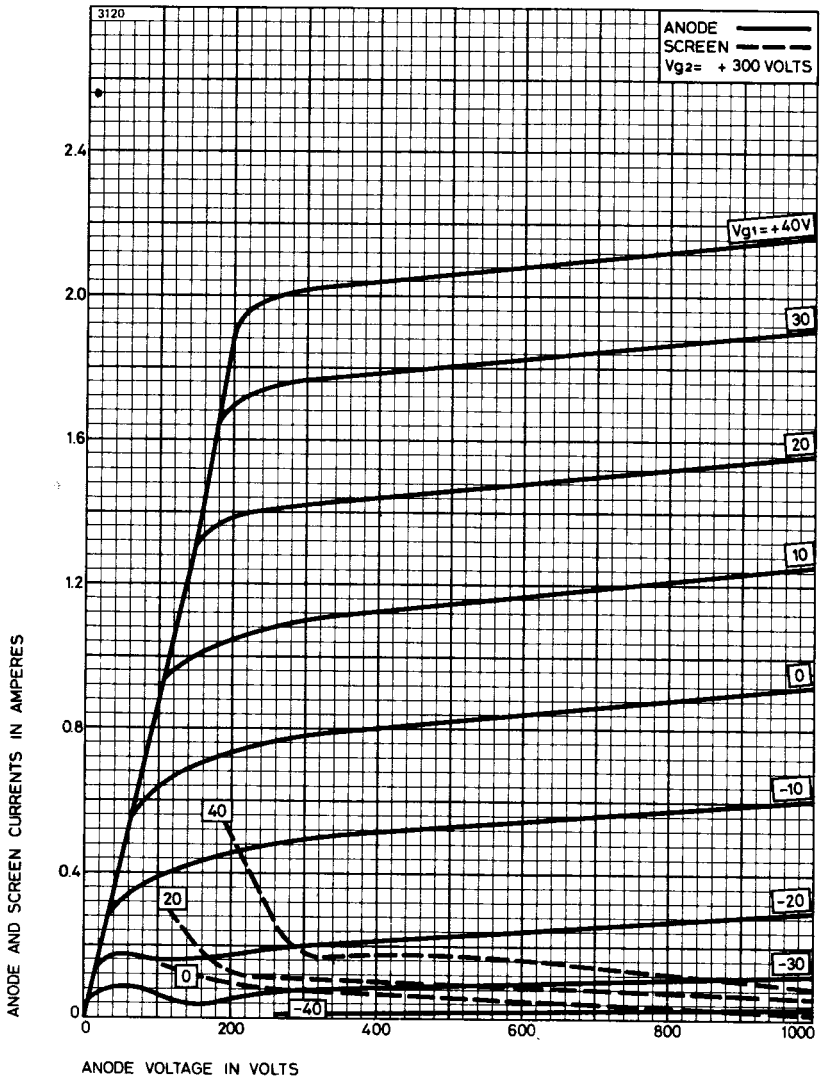

TYPICAL CONSTANT CURRENT CHARACTERISTICS

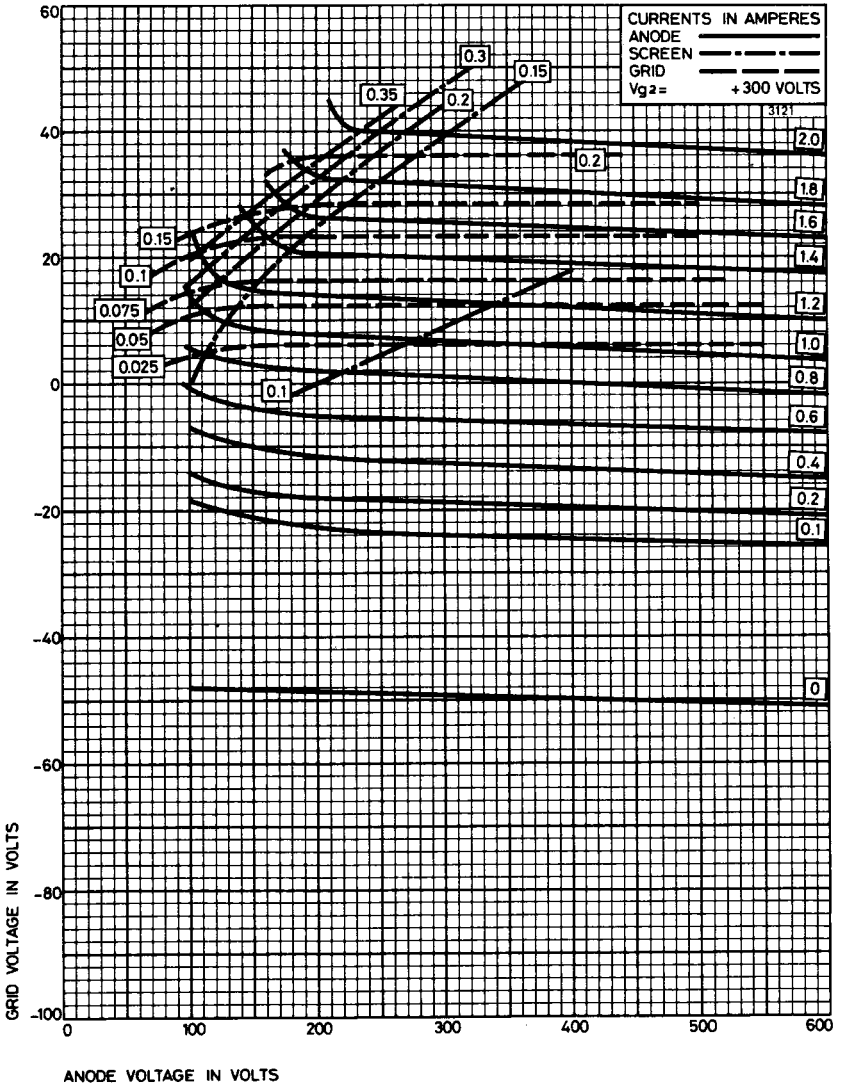

OUTLINE (All dimensions without limits are nominal)

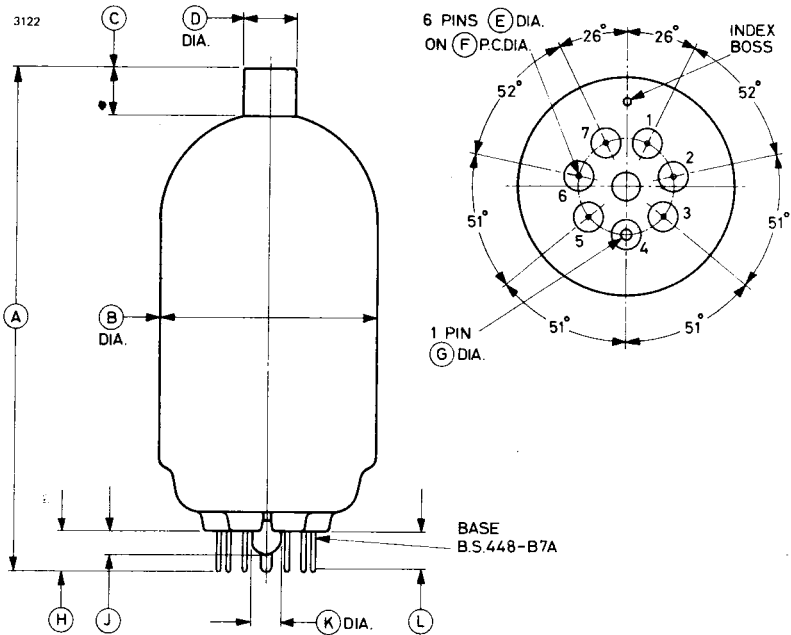

Ref	Inches	Millimetres
A	5.250 ± 0.500	133.4 ± 12.7
B	2.312 max	58.72 max
C	0.500	12.70
D	0.566	14.38
E	0.058 ^{+ 0.002} - 0.006	1.473 ^{+ 0.051} - 0.152
F	1.000	25.40
G	0.125 ± 0.003	3.175 ± 0.076
H	0.438 ± 0.062	11.13 ± 1.57
J	0.375 max	9.53 max
K	0.375 max	9.53 max
L	0.312 min	7.92 min

Pin	Element
1	Heater
2	Screen
3	No connection
4	Cathode and
5	beam plates
6	Grid
7	Heater
Cap	Anode

Millimetre dimensions have been derived from inches.



C178A/5894

BEAM POWER DOUBLE TETRODE

Service Type CV2797

The data should be read in conjunction with the Power Tetrode Preamble.

ABRIDGED DATA

V.H.F. double tetrode, with centre-tapped heater for series or parallel operation.

Anode dissipation	2 x 20	W max
Anode voltage	600	V max
Frequency for full ratings	250	MHz max
Frequency at reduced ratings	500	MHz max
Output power (class C telegraphy, 2 sections in push-pull)	90	W

GENERAL

Electrical

Cathode	indirectly heated, oxide coated		
	Series	Parallel	
Heater voltage	12.6	6.3	V
Heater current	0.9	1.8	A
Grid-screen amplification factor (each unit) ($I_a = 30\text{mA}$)		8.0	
Mutual conductance (each unit) ($I_a = 30\text{mA}$)		4.5	mA/V
Inter-electrode capacitances (see note 1):			
grid to anode*		0.06	pF max
input		10.5	pF
output		3.2	pF
input (two sections in push-pull)		6.7	pF
output (two sections in push-pull)		2.1	pF

* Internally neutralised for push-pull operation.

Mechanical

Overall length	104.5mm (4.118 inches) max
Overall diameter	46.0mm (1.810 inches) max
Net weight	85g (3 ounces) approx
Mounting position	vertical, base up or down
Horizontal operation is permitted with fixed station operation when the anode pins are in a horizontal plane.	
Base	B.S.448-B7A (JEDEC no. E7-2)

COOLING

The temperature of the seals must not exceed the values given below:

anode seal or bulb temperature	200	°C max
base pin seal temperature	180	°C max

A heat dissipating anode connection of large surface area or high heat conduction is necessary.

Natural cooling is normally sufficient at maximum ratings for frequencies up to 150MHz. At higher frequencies it may be necessary to direct an air flow of up to 5ft³/min (0.14m³/min) on to the anode and base seals.

AUDIO FREQUENCY POWER AMPLIFIER AND MODULATOR (Class B)

MAXIMUM RATINGS (Absolute values)

Anode voltage	600	V max
Anode dissipation	2 x 20	W max
Screen voltage	300	V max
Screen dissipation	2 x 3.5	W max
Grid dissipation	2 x 1.0	W max
Grid resistor (fixed bias)	50	kΩ max
Grid resistor (cathode bias)	100	kΩ max
Cathode current (peak)	2 x 450	mA max
Cathode current (mean)	2 x 140	mA max
Peak heater to cathode voltage	100	V max

TYPICAL OPERATING CONDITIONS (Class B, no grid current, 2 valves)

Anode voltage	300	450	600	V
Screen voltage	250	250	250	V
Grid voltage	-26	-27	-27	V
Peak a.f. input voltage (grid to grid)	51	54	55	V
Maximum-signal anode current	2 x 56	2 x 58	2 x 62	mA
Zero-signal anode current	2 x 20	2 x 20	2 x 20	mA
Maximum-signal screen current	2 x 14	2 x 13.5	2 x 11.5	mA
Zero-signal screen current	2 x 1.0	2 x 0.7	2 x 0.45	mA
Effective load (anode to anode)	6.5	10	12.5	kΩ
Anode dissipation	2 x 5.6	2 x 8.5	2 x 12	W
Output power	22.5	35	50	W
Efficiency	67	67.5	67.5	%
Total distortion	2.9	3.1	2.4	%

TYPICAL OPERATING CONDITIONS (Class B with grid current, 2 valves)

Anode voltage	300	450	600	V
Screen voltage	250	250	250	V
Grid voltage	-25	-25	-25	V
Peak a.f. input voltage (grid to grid)	74	76	78	V
Maximum-signal anode current	2 x 94	2 x 97	2 x 100	mA
Zero-signal anode current . . .	2 x 25	2 x 25	2 x 25	mA
Maximum-signal screen current .	2 x 14	2 x 14	2 x 13	mA
Zero-signal screen current . . .	2 x 1.4	2 x 0.95	2 x 0.7	mA
Grid current	2 x 2.6	2 x 2.6	2 x 2.6	mA
Effective load (anode to anode) . .	4.0	6.0	8.0	k Ω
Anode dissipation	2 x 9.7	2 x 13.5	2 x 17	W
Output power	37	60	86	W
Efficiency	65.5	69	71.5	%
Total distortion	5.0	5.0	5.0	%

R.F. POWER AMPLIFIER – ANODE AND SCREEN MODULATED

(Class C telephony, carrier conditions per valve for use with a maximum modulation factor of 1.0)

MAXIMUM RATINGS (Absolute values)

Anode voltage	600	V max
Anode dissipation	2 x 14	W max
Screen voltage	300	V max
Screen dissipation	2 x 2.3	W max
Grid voltage (negative value)	175	V max
Grid current	2 x 5.0	mA max
Grid dissipation	2 x 1.0	W max
Grid resistor (fixed bias)	50	k Ω max
Grid resistor (cathode bias)	100	k Ω max
Cathode current (peak)	2 x 1.0	A max
Cathode current (mean)	2 x 120	mA max
Peak heater to cathode voltage	100	V max

TYPICAL OPERATING CONDITIONS

Frequency	60	200	200	MHz
Anode voltage	600	400	600	V
Screen voltage	250	250	250	V
Grid voltage	-80	-70	-80	V
Anode current	2 x 75	2 x 75	2 x 75	mA
Screen current	2 x 10	2 x 9.0	2 x 9.0	mA
Grid current (approx)	2 x 4.0	2 x 2.0	2 x 2.0	mA
Anode dissipation	2 x 9.5	2 x 9.5	2 x 11.5	W
Output power	71	41	67	W
Efficiency	79	69	75	%

Frequency	250	400	475	MHz
Anode voltage	600	400	400	V
Screen voltage	250	250	250	V
Grid voltage	-80	-70	-70	V
Anode current	2 x 75	2 x 75	2 x 75	mA
Screen current	2 x 9.0	2 x 8.0	2 x 7.5	mA
Grid current (approx)	2 x 1.5	2 x 1.5	2 x 1.5	mA
Anode dissipation	2 x 13	2 x 11.5	2 x 13	W
Output power	64	37	34	W
Efficiency	71	62	57	%

PUSH-PULL R.F. POWER AMPLIFIER AND OSCILLATOR

(Class C telegraphy, key-down conditions, one valve)

MAXIMUM RATINGS (Absolute values)

Anode voltage	600	V max
Anode dissipation	2 x 20	W max
Screen voltage	300	V max
Screen dissipation	2 x 3.5	W max
Grid voltage	-100	V max
Grid current	2 x 5	mA max
Grid resistor (fixed bias)	50	kΩ max
Grid resistor (cathode bias)	100	kΩ max
Cathode current (peak)	2 x 700	mA max
Cathode current (mean)	2 x 120	mA max
Peak heater to cathode voltage	100	V max

TYPICAL OPERATING CONDITIONS

Frequency	200	200	400	400	MHz
Anode voltage	400	600	400	540	V
Screen voltage (see note 2)	250	250	250	250	V
Grid voltage	-60	-80	-50	-55	V
Anode current	2 x 100	2 x 100	2 x 100	2 x 100	mA
Screen current	2 x 8	2 x 9	2 x 5	2 x 7	mA
Grid current (approx)	2 x 3.0	2 x 3.5	2 x 2.0	2 x 1.5	mA
Driving power (approx)	3.0	3.0	11	12	W
Output power (approx)	56	90	50	70	W

Frequency		475	475	MHz
Anode voltage		350	500	V
Screen voltage (see note 2)		250	250	V
Grid voltage		-45	-50	V
Anode current		2 x 100	2 x 100	mA
Screen current		2 x 4.5	2 x 4.5	mA
Grid current (approx)		2 x 2.0	2 x 2.0	mA
Driving power (approx)		10	12	W
Output power (approx)		40	60	W

RANGE OF CHARACTERISTICS FOR EQUIPMENT DESIGN

	Min	Max	
Heater current at heater voltage 6.3V	1.6	2.0	A
Change of grid voltage ($V_a = 600V$, $V_{g2} = (1) 250V, (2) 200V, I_a = 40mA$)	5.2	7.5	V
Anode current ($V_a = 600V$, $V_{g2} = 250V, V_{g1} = -40V$)	—	5.0	mA

NOTES

1. Inter-electrode capacitances are for each unit except where otherwise indicated.
2. Screen voltage may be obtained from a separate source, or from the anode supply with a potential divider or through a series resistor. The screen voltage must not exceed 600V under key-up conditions.

TYPICAL ANODE CHARACTERISTICS (ONE UNIT ONLY)

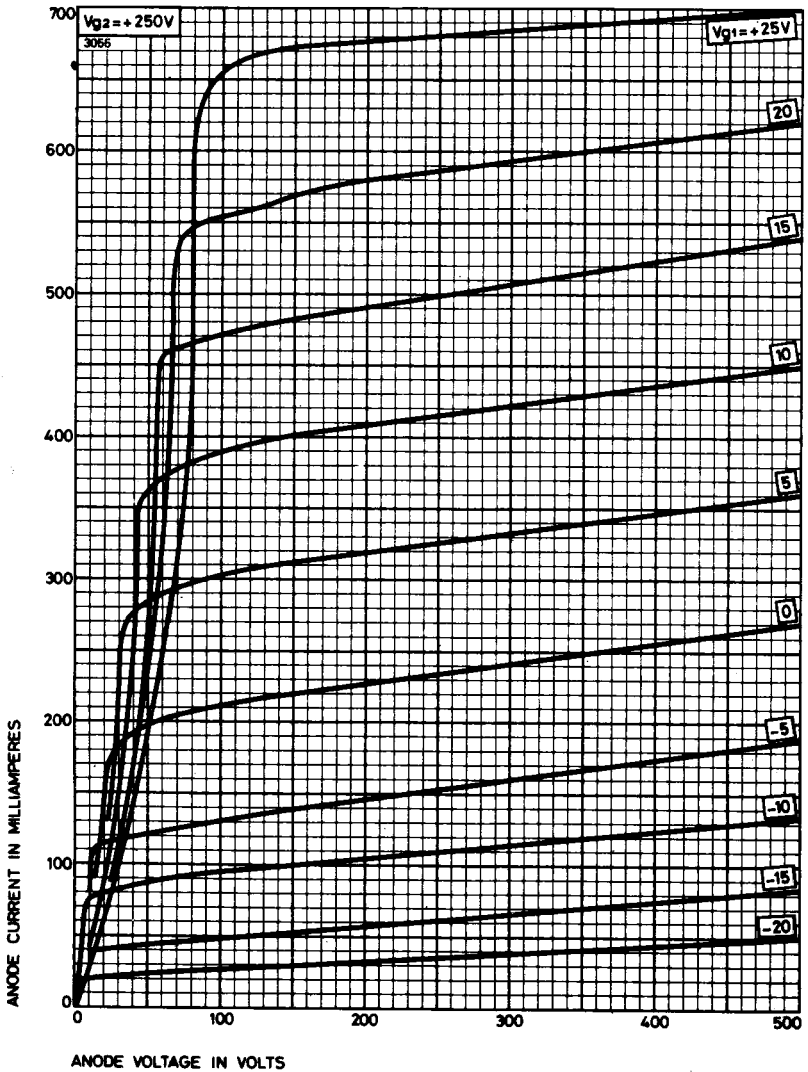

TYPICAL ANODE CHARACTERISTICS (ONE UNIT ONLY)

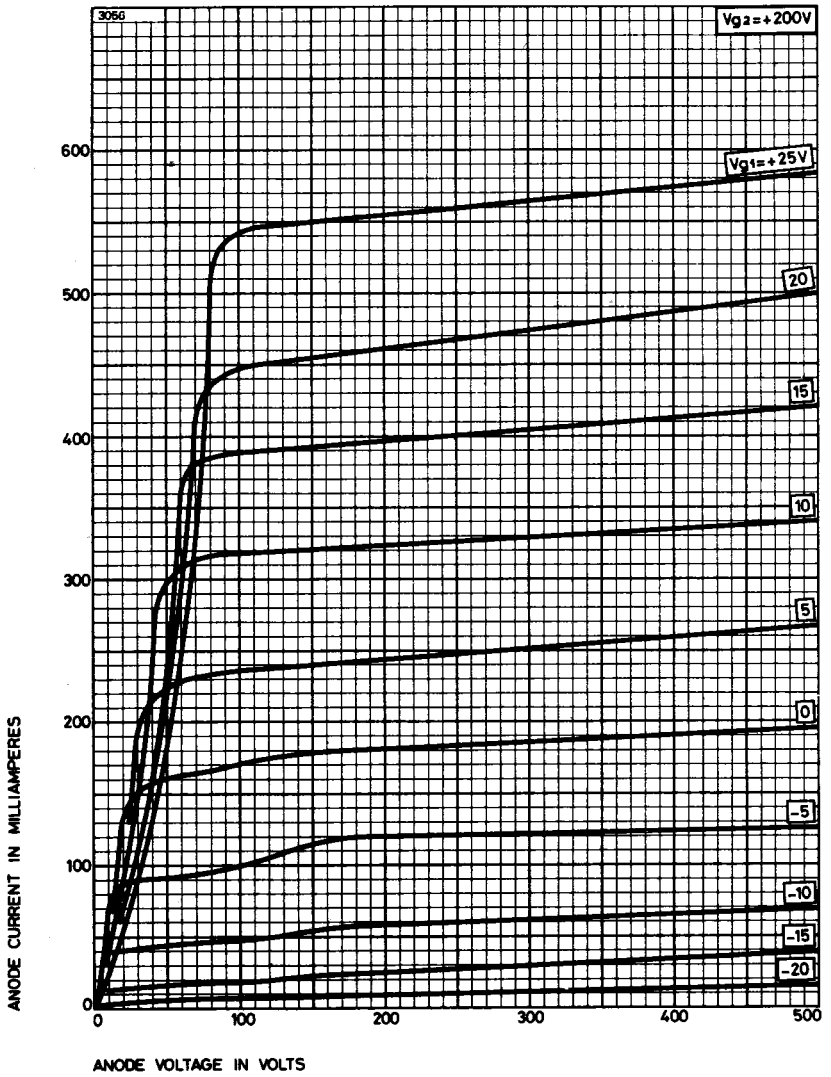

TYPICAL SCREEN CHARACTERISTICS (ONE UNIT ONLY)

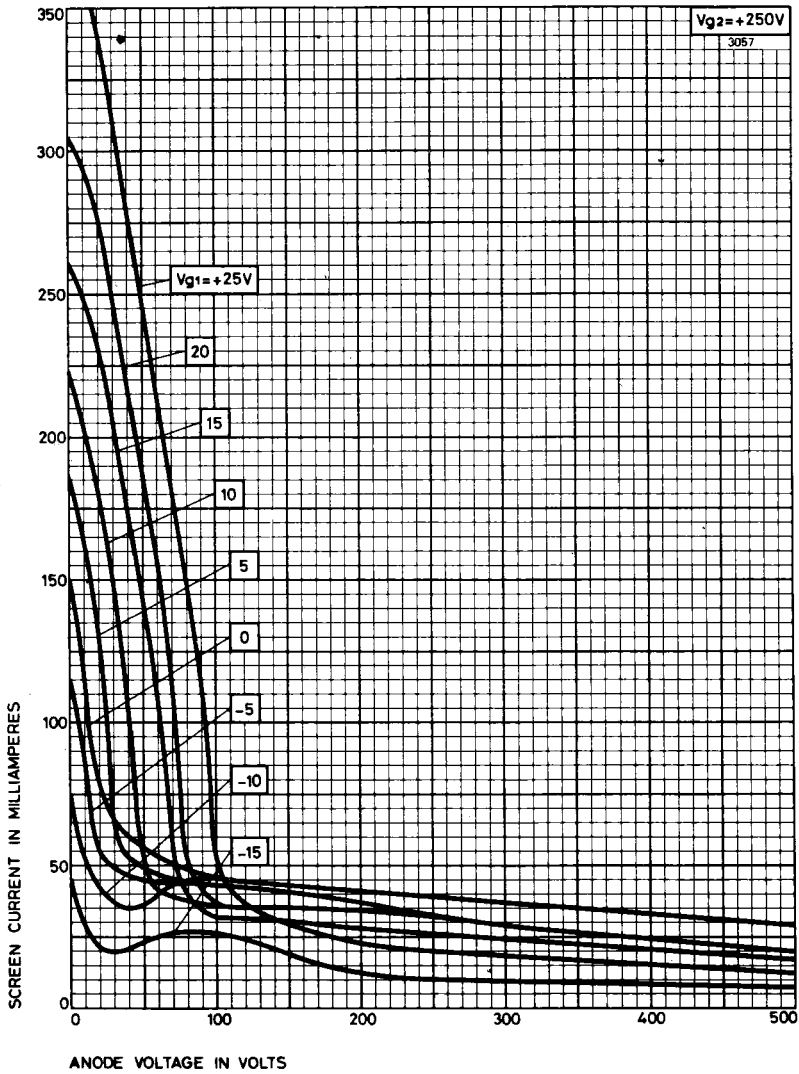

TYPICAL SCREEN CHARACTERISTICS (ONE UNIT ONLY)

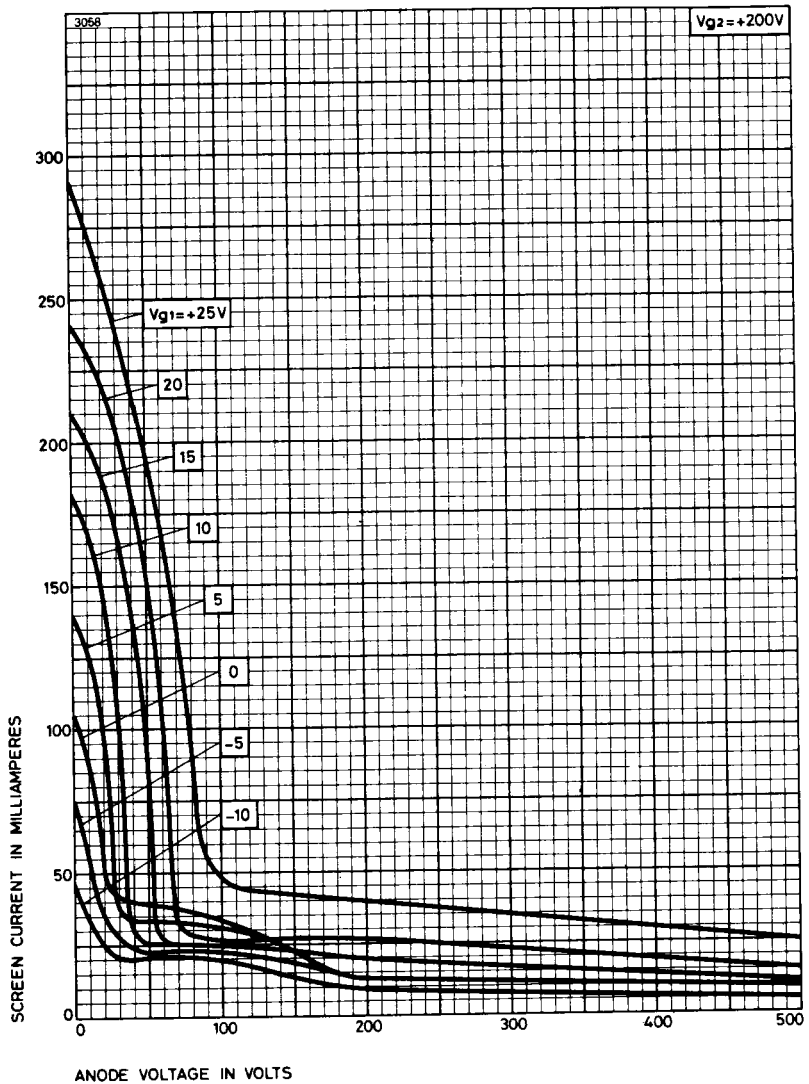

TYPICAL GRID CHARACTERISTICS (ONE UNIT ONLY)

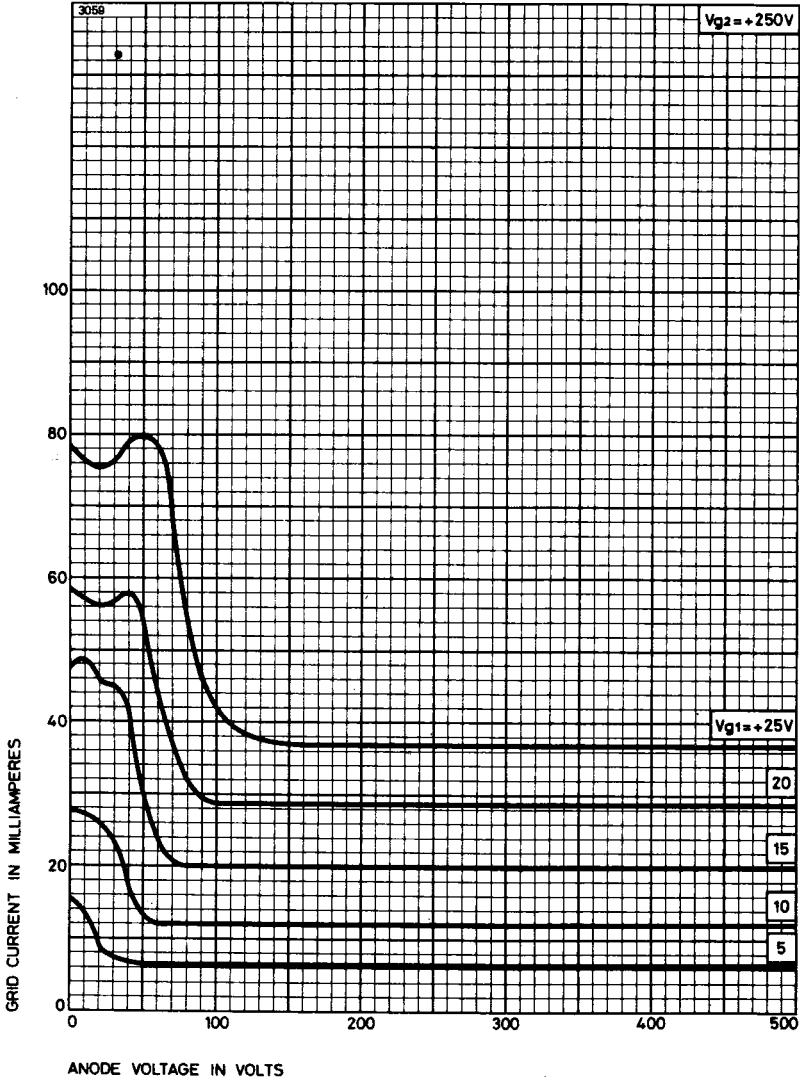

TYPICAL GRID CHARACTERISTICS (ONE UNIT ONLY)

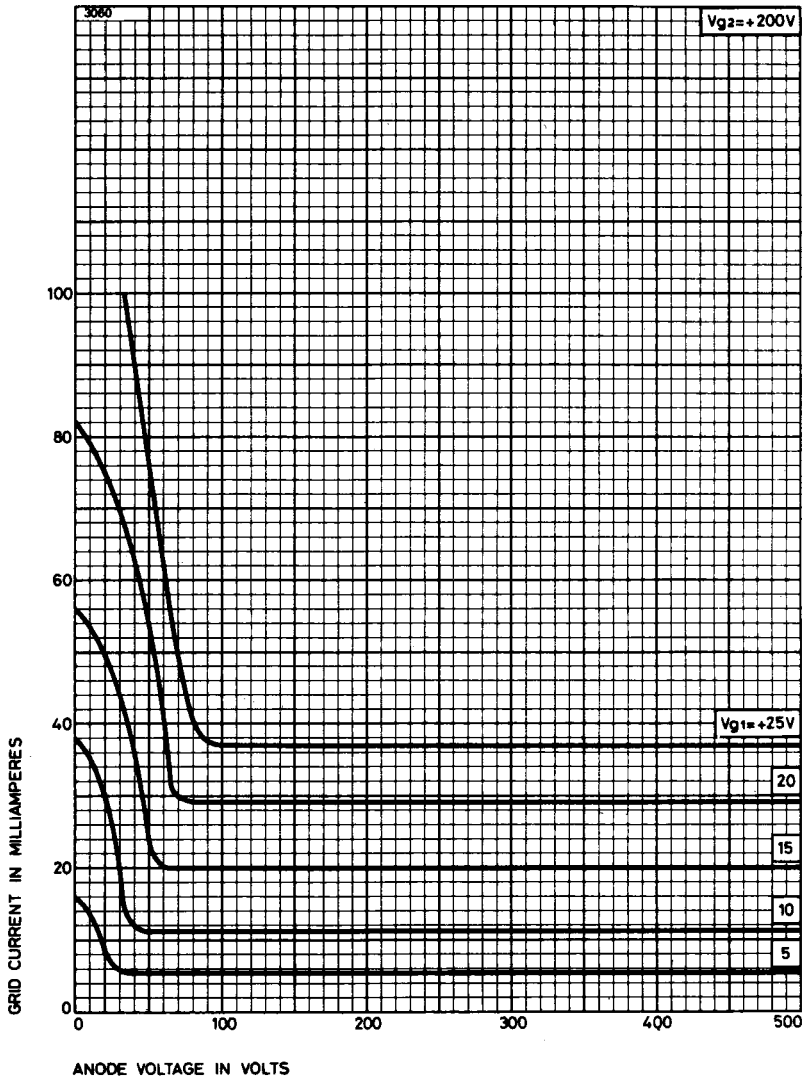

**TYPICAL CONSTANT CURRENT CHARACTERISTICS
(ONE UNIT ONLY)**

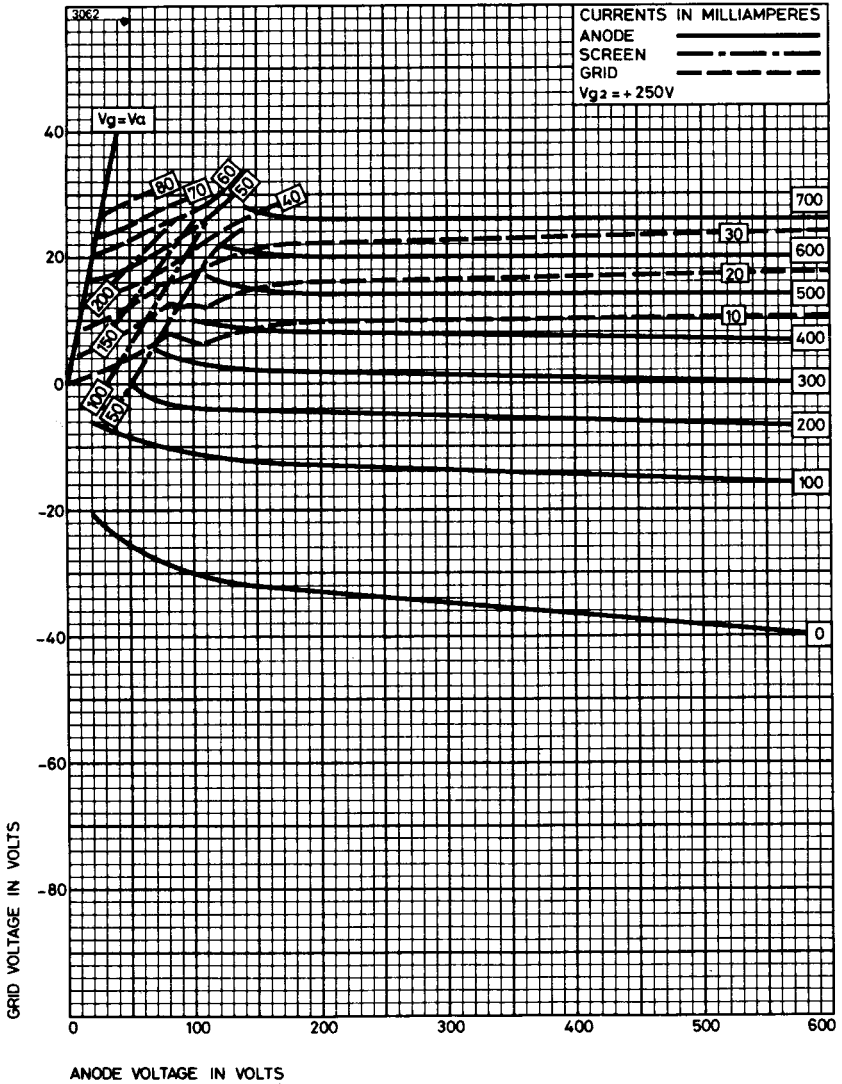

**TYPICAL CONSTANT CURRENT CHARACTERISTICS
(ONE UNIT ONLY)**

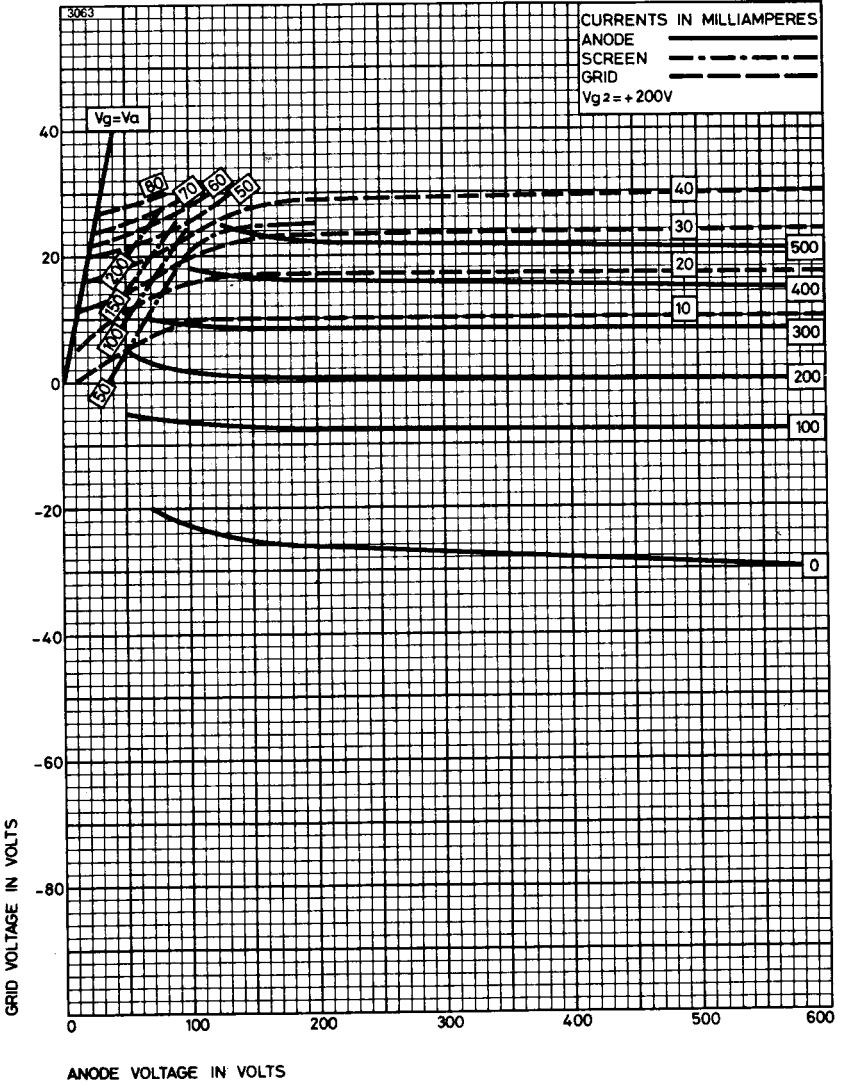

OUTLINE (All dimensions without limits are nominal)

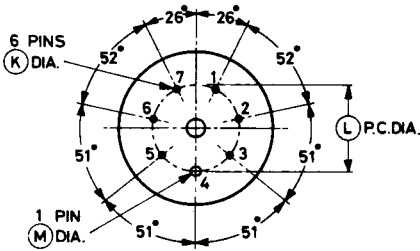
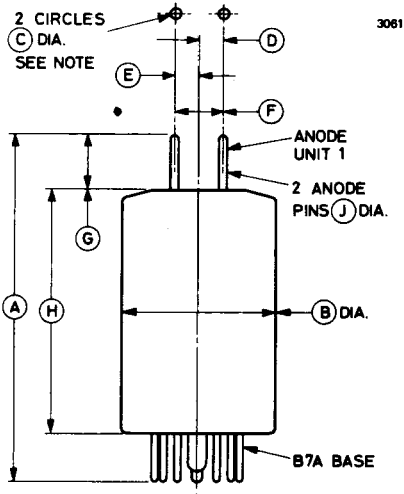

Pin	Element
1	Heater
2	Grid, unit 1
3	Screen, common
4	Cathode, beam plates, shield
5	Heater centre tap
6	Grid, unit 2
7	Heater

Note The location of the anode pins will be within the two circles.

Ref	Millimetres	Inches	Ref	Millimetres	Inches
A	104.5 max	4.114 max	H	74.5 max	2.933 max
B	46.0 max	1.811 max	J	2.0	0.079
C	3.6	0.142	K*	1.473 + 0.051	0.058 + 0.002
D	7.0	0.276		- 0.152	- 0.006
E	7.0	0.276	L*	25.4	1.000
F	14.0 ± 1.0	0.550 ± 0.040	M*	3.175 ± 0.076	0.125 ± 0.003
G	16.5 ± 1.5	0.650 ± 0.059			

Inch dimensions have been derived from millimetres except where marked *



R.F. POWER TETRODE

Service Type CV2130

The data should be read in conjunction with the Power Tetrode Preamble.

ABRIDGED DATA

V.H.F. radial beam transmitting tetrode.

Anode dissipation	125	W max
Anode voltage	3.0	kV max
Frequency for full ratings	120	MHz max
Frequency at reduced ratings	200	MHz max
Output power (class C unmodulated conditions)	375	W

GENERAL

Electrical

Filament	thoriated tungsten
Filament voltage	5.0 V
Filament current	6.5 A
Peak usable cathode current	1.2 A
Perveance	0.4 mA/V ^{3/2}
Grid-screen amplification factor ($V_a = 2.5\text{kV}$, $V_{g2} = 350\text{V}$, $I_a = 40\text{mA}$)	6.2
Mutual conductance ($V_a = 2.5\text{kV}$, $V_{g2} = 350\text{V}$, $I_a = 40\text{mA}$)	2.2 mA/V
Inter-electrode capacitances:	
input	10.8 pF
output	3.1 pF
grid to anode	0.05 pF

Mechanical

Overall length	129.5mm (5.100 inches) max
Overall diameter	62.0mm (2.440 inches) max
Net weight	113g (4 ounces) approx
Mounting position	vertical, base up or down
Base	B.S.448-B5F

COOLING

The temperatures given below must not be exceeded. When operating at frequencies above 50MHz, an adequate flow of air must be provided to limit the temperature of the envelope and glass to metal seals. Natural cooling is normally adequate for frequencies below 50MHz provided that a heat dissipating anode connector of large surface area is used.

Anode seal temperature	220	°C max
Base pin seal temperature	180	°C max

AUDIO FREQUENCY POWER AMPLIFIER OR MODULATOR (Class B)

MAXIMUM RATINGS (Absolute values)

Anode voltage	3.0	kV max
Anode dissipation	125	W max
Screen voltage:		
with no grid current	600	V max
with grid current	400	V max
Screen dissipation	20	W max
Grid voltage (negative value)	500	V max
Grid to cathode resistance	150	kΩ max
Cathode current (mean)	0.32	A max

TYPICAL OPERATING CONDITIONS

(Class B without grid current, 2 valves)

Anode voltage	1.5	2.0	2.5	kV
Screen voltage	600	600	600	V
Grid voltage	-94	-96	-97	V
Peak a.f. input voltage (grid to grid)	184	187	190	V
Maximum-signal anode current	2 x 109	2 x 111	2 x 108	mA
Zero-signal anode current . . .	2 x 30	2 x 30	2 x 30	mA
Maximum-signal screen current .	2 x 13.5	2 x 12	2 x 13	mA
Effective load (anode to anode) .	12	17.6	25	kΩ
Anode dissipation	2 x 78	2 x 92	2 x 95	W
Output power	170	260	345	W
Efficiency	52	58.5	64	%
Total distortion	3.5	3.6	4.0	%

Continued on page 3

TYPICAL OPERATING CONDITIONS

(Class B with grid current, 2 valves)

Anode voltage	1.5	2.0	2.5	kV
Screen voltage	350	350	350	V
Grid voltage	-48	-50	-51	V
Peak a.f. input voltage (grid to grid)	331	297	240	V
Maximum-signal anode current	2 x 225	2 x 197	2 x 151	mA
Zero-signal anode current	2 x 30	2 x 30	2 x 30	mA
Maximum signal screen current	2 x 42	2 x 32	2 x 18	mA
Grid current	2 x 16	2 x 12	2 x 8.5	mA
Effective load (anode to anode)	7.2	12	20	k Ω
Anode dissipation	2 x 114	2 x 120	2 x 103	W
Output power	455	550	550	W
Efficiency	66.5	69.5	72.5	%
Total distortion	5.0	5.0	5.0	%

RADIO FREQUENCY POWER AMPLIFIER

(Class B telephony, carrier conditions per valve for use with a maximum modulation factor of 1.0)

MAXIMUM RATINGS (Absolute values)

Anode voltage	3.0	kV max
Anode dissipation	125	W max
Screen voltage	400	V max
Screen dissipation	14	W max
Cathode current (mean)	120	mA max

TYPICAL OPERATING CONDITIONS (at frequencies up to 120MHz)

Anode voltage	2.0	2.5	3.0	kV
Screen voltage	350	350	350	V
Grid voltage	-50	-50	-50	V
Peak r.f. grid voltage	65	55	50	V
Anode current	83	70	60	mA
Screen current	1.5	1.0	1.0	mA
Grid current (modulation factor 1.0)	4.0	4.0	4.5	mA
Anode dissipation	112	120	122	W
Screen dissipation	0.52	0.35	0.35	W
Nominal driving power (modulation factor 1.0)	0.52	0.44	0.45	W
Output power	54	55	58	W
Efficiency	32.5	31.5	32	%

ANODE AND SCREEN MODULATED R.F. POWER AMPLIFIER
(Class C telephony, carrier conditions per valve for use with a maximum modulation factor of 1.0)

MAXIMUM RATINGS (Absolute values)

Anode voltage	2.5	kV max
Anode dissipation	83	W max
Screen voltage	400	V max
Screen dissipation	20	W max
Grid voltage (negative value)	500	V max
Grid current	15	mA max
Cathode current (mean)	0.2	A max

TYPICAL OPERATING CONDITIONS (at frequencies up to 120MHz)

Anode voltage	2.0	2.5	kV
Screen voltage	350	350	V
Grid voltage	-220	-210	V
Peak r.f. grid voltage	390	380	V
Peak screen modulating voltage (modulation factor 1.0)	300	300	V
Anode current	150	152	mA
Screen current	33	30	mA
Grid current	5.0	4.5	mA
Anode dissipation	75	80	W
Screen dissipation	11.5	10.5	W
Nominal driving power	2.0	1.7	W
Output power	225	300	W
Efficiency	75	79	%

R.F. POWER AMPLIFIER OR OSCILLATOR

(Class C telegraphy, key-down conditions, one valve)

MAXIMUM RATINGS (Absolute values)

Anode voltage	3.0	kV max
Anode dissipation	125	W max
Screen voltage	400	V max
Screen dissipation	20	W max
Grid voltage (negative value)	500	V max
Grid current	15	mA max
Grid dissipation	5.0	W max
Cathode current (mean)	0.3	A max

TYPICAL OPERATING CONDITIONS (at frequencies up to 120MHz)

Anode voltage	2.0	2.5	3.0	kV
Screen voltage	350	350	350	V
Grid voltage	-100	-150	-150	V
• Peak r.f. grid voltage	260	330	300	V
Anode current	200	200	167	mA
Screen current	50	40	30	mA
Grid current	9.0	9.0	6.5	mA
Anode dissipation	125	125	125	W
Screen dissipation	17.5	14	10.5	W
Nominal driving power	2.4	3.0	2.0	W
Output power	275	375	375	W
Efficiency	69	75	75	%



TYPICAL ANODE CHARACTERISTICS

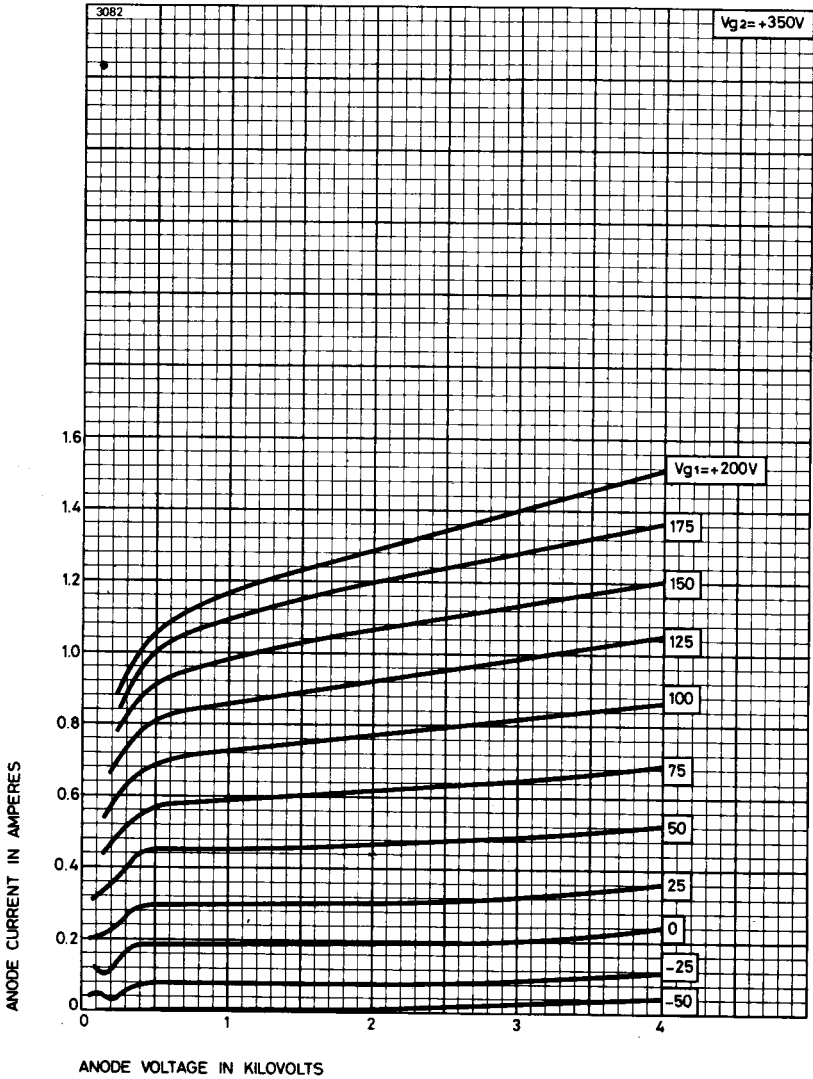

TYPICAL SCREEN CHARACTERISTICS

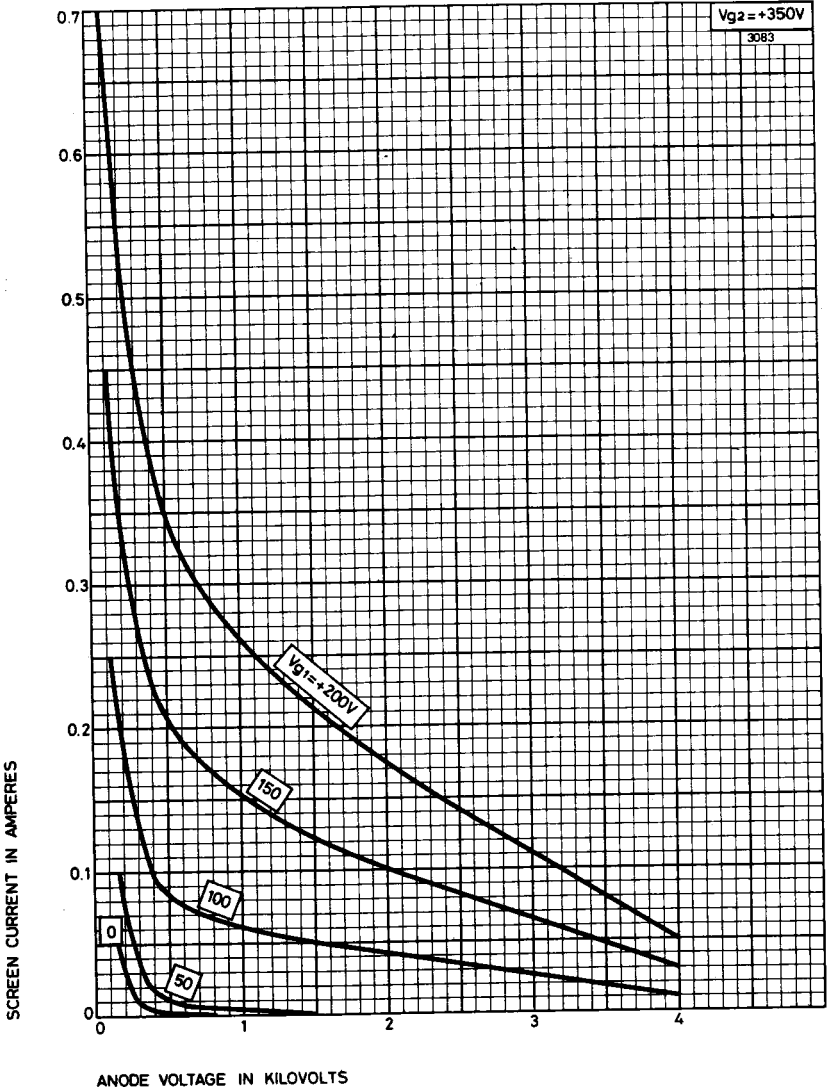

TYPICAL GRID CHARACTERISTICS

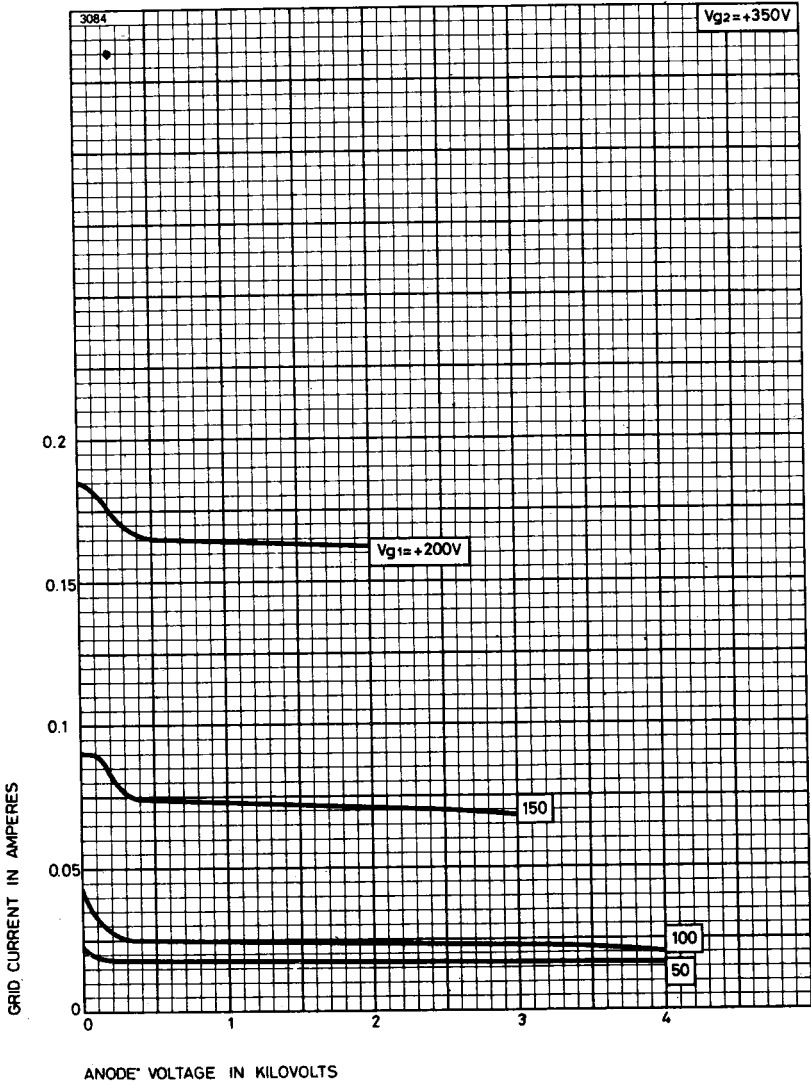

TYPICAL CONSTANT CURRENT CHARACTERISTICS

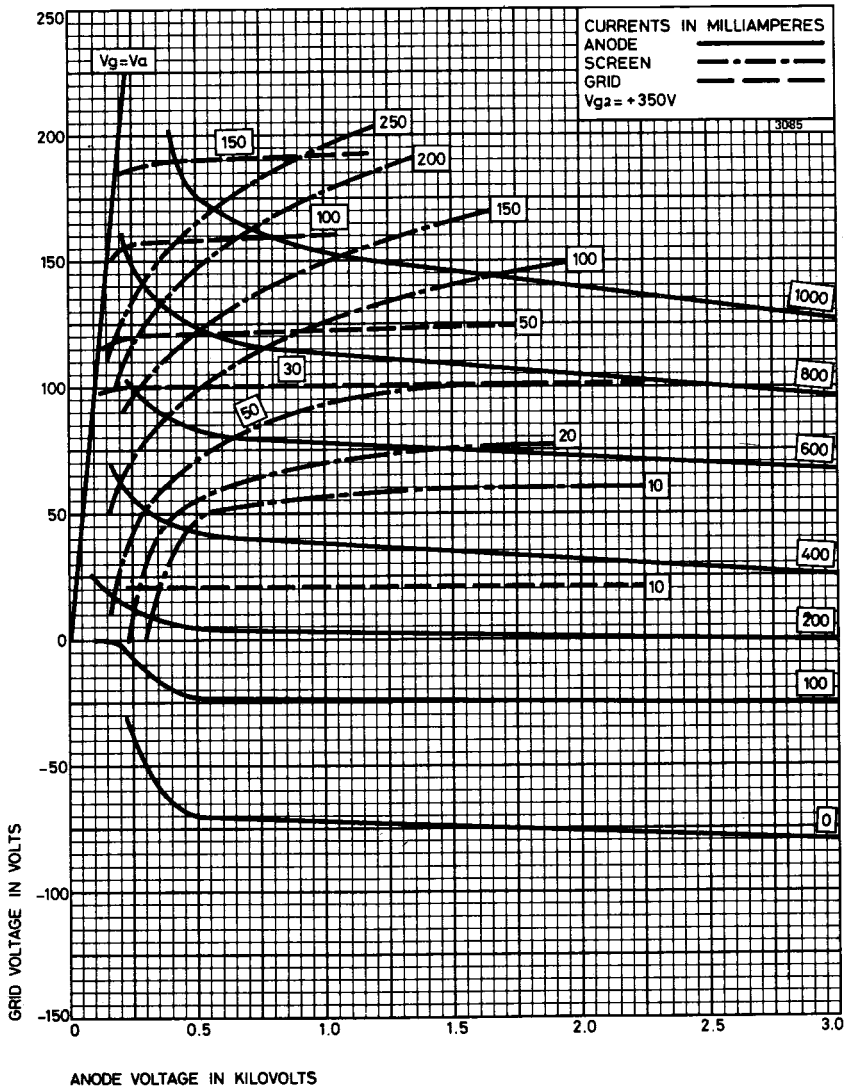

OUTLINE

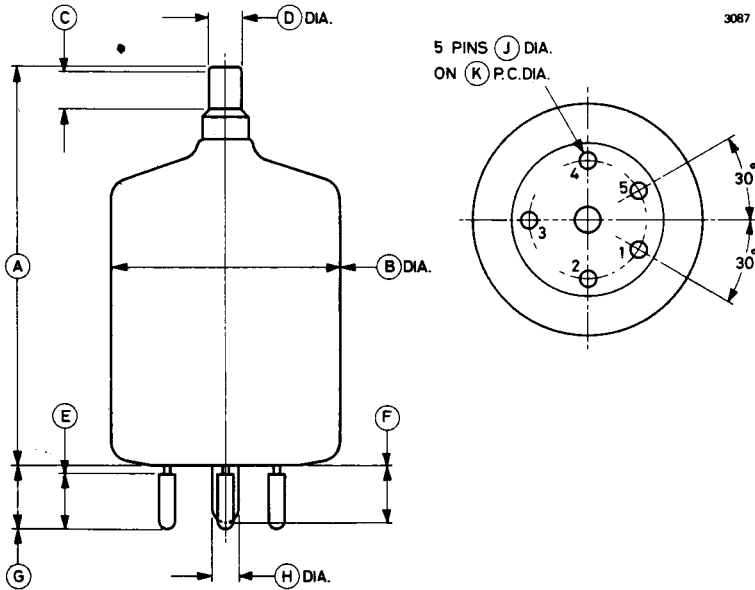

3087

Ref	Millimetres	Inches
A	106.0 ± 6.0	4.173 ± 0.236
B	62.0 max	2.440 max
C	9.00 min	0.354 min
D	9.00 ± 0.13	0.354 ± 0.005
E	15.0 ± 0.2	0.591 ± 0.007
F	15.0 max	0.591 max
G	17.0 ± 0.5	0.670 ± 0.020
H	7.50 max	0.295 max
J	4.75 ± 0.07	0.187 ± 0.003
K	31.75	1.250

Pin	Element
1	Filament
2	Screen
3	Grid
4	Screen
5	Filament
Cap	Anode

Inch dimensions have been derived from millimetres.



BEAM POWER TETRODE

Service Type CV2131

The data should be read in conjunction with the Power Tetrode Preamble.

ABRIDGED DATA

V.H.F. radial beam transmitting tetrode

Anode dissipation	250	W max
Anode voltage	4.0	kV max
Frequency for full ratings	75	MHz max
Frequency at reduced ratings	120	MHz max
Output power (class C unmodulated)	1.0	kW

GENERAL

Electrical

Filament	thoriated tungsten
Filament voltage	5.0 V
Filament current	14.1 A
Peak usable cathode current	2.0 A
Perveance	0.65 mA/V ^{3/2}
Grid-screen amplification factor ($V_a = 2.5\text{kV}$, $V_{g2} = 500\text{V}$, $I_a = 100\text{mA}$)	5.1
Mutual conductance ($V_a = 2.5\text{kV}$, $V_{g2} = 500\text{V}$, $I_a = 100\text{mA}$)	4.0 mA/V
Inter-electrode capacitances:	
input	12.7 pF
output	4.5 pF
grid to anode	0.12 pF

Mechanical

Overall length	151mm (5.944 inches) max
Overall diameter	87mm (3.425 inches) max
Net weight	170g (6 ounces) approx
Mounting position	vertical, base up or down
Base	B.S.448-B5F

COOLING

An adequate flow of air must be provided to cool the envelope and glass to metal seals of the valve when operating at frequencies above 30MHz, or under conditions where the maximum values of temperature given below might be exceeded.

Anode seal temperature	220	°C max
Base pin seal temperature	180	°C max

A heat dissipating anode connector of large surface area is necessary.

AUDIO FREQUENCY POWER AMPLIFIER OR MODULATOR (Class B)

MAXIMUM RATINGS (Absolute values)

Anode voltage	4.0	kV max
Anode dissipation	250	W max
Screen voltage	600	V max
Screen dissipation	35	W max
Grid voltage (negative value)	500	V max
Grid dissipation	10	W max
Grid to filament resistance	250	kΩ max
Cathode current (mean)	450	mA max

TYPICAL OPERATING CONDITIONS

(Class B without grid current, 2 valves)

Anode voltage	2.0	2.5	3.0	kV
Screen voltage	500	500	500	V
Grid voltage	-88	-91	-94	V
Peak a.f. input voltage (grid to grid)	172	178	184	V
Maximum-signal anode current	2 x 150	2 x 155	2 x 155	mA
Zero-signal anode current	2 x 50	2 x 50	2 x 50	mA
Maximum-signal screen current	2 x 14	2 x 10	2 x 10	mA
Effective load (anode to anode)	14.5	18	22	kΩ
Anode dissipation	2 x 105	2 x 132	2 x 147	W
Output power	390	510	635	W
Efficiency	65	66	68	%
Total distortion	3.2	2.6	2.8	%

TYPICAL OPERATING CONDITIONS

(Class B with grid current, 2 valves)

Anode voltage	2.0	2.5	3.0	kV
Screen voltage	300	300	300	V
Grid voltage	-49	-51	-55	V
Peak a.f. input voltage (grid to grid)	328	306	280	V
Maximum-signal anode current	2 x 347	2 x 312	2 x 275	mA
Zero-signal anode current	2 x 50	2 x 50	2 x 50	mA
Maximum-signal screen current	2 x 55	2 x 44	2 x 34.5	mA
Grid current	2 x 38	2 x 30	2 x 21	mA
Effective load (anode to anode)	6.6	9.2	14	kΩ
Anode dissipation	2 x 207	2 x 210	2 x 205	W
Nominal driving power	2 x 6.0	2 x 4.0	2 x 2.7	W
Output power	974	1140	1240	W
Efficiency	70	73	75	%
Total distortion	5.0	5.0	5.0	%

RADIO FREQUENCY POWER AMPLIFIER

(Class B telephony, carrier conditions per valve for use with a maximum modulation factor of 1.0)

MAXIMUM RATINGS (Absolute values)

Anode voltage	4.0	kV max
Anode dissipation	250	W max
Screen voltage	600	V max
Screen dissipation	23	W max
Grid dissipation	6.5	W max
Grid to filament resistance	250	kΩ max
Cathode current (mean)	200	mA max

TYPICAL OPERATING CONDITIONS (for frequencies up to 75MHz)

Anode voltage	2.5	3.0	4.0	kV
Screen voltage	500	500	500	V
Grid voltage	-84	-90	-100	V
Peak r.f. grid voltage	66	61	56	V
Anode current	150	125	94	mA
Grid current (modulation factor 1.0)	7.7	2.8	0.7	mA
Anode dissipation	250	250	250	W
Screen dissipation (modulation factor 1.0)	6.0	3.8	4.0	W
Nominal driving power	1.4	0.6	0.35	W
Output power	125	125	126	W
Efficiency	33	33	33.5	%

ANODE AND SCREEN MODULATED R.F. POWER AMPLIFIER

(Class C telephony, carrier conditions per valve for use with a maximum modulation factor of 1.0)

MAXIMUM RATINGS (Absolute values)

Anode voltage	3.2	kV max
Anode dissipation	165	W max
Screen voltage	600	V max
Screen dissipation	35	W max
Grid voltage (negative value)	500	V max
Grid dissipation	10	W max
Grid to filament resistance	250	k Ω max
Cathode current (mean)	270	mA max

TYPICAL OPERATING CONDITIONS (for frequencies up to 75MHz)

Anode voltage	2.5	3.0	kV
Screen voltage	400	400	V
Grid voltage	-200	-310	V
Peak r.f. grid voltage	280	400	V
Peak screen modulating voltage (modulation factor 1.0)	350	350	V
Anode current	200	225	mA
Screen current	30	30	mA
Grid current	13	13	mA
Anode dissipation	125	165	W
Screen dissipation	12	12	W
Nominal driving power	3.8	5.5	W
Output power	375	510	W
Efficiency	75	75.5	%

R.F. POWER AMPLIFIER OR OSCILLATOR

(Class C telegraphy, key-down conditions, one valve)

MAXIMUM RATINGS (Absolute values)

Anode voltage	4.0	kV max
Anode dissipation	250	W max
Screen voltage	600	V max
Screen dissipation	35	W max
Grid voltage (negative value)	500	V max
Grid dissipation	10	W max
Grid to filament resistance	250	k Ω max
Cathode current (mean)	420	mA max

TYPICAL OPERATING CONDITIONS (for frequencies up to 75MHz)

Anode voltage	2.5	3.0	4.0	kV
Screen voltage	500	500	500	V
Grid voltage	-150	-180	-225	V
Peak r.f. grid voltage	220	265	303	V
Anode current	300	345	312	mA
Screen current	60	60	45	mA
Grid current	13	15	13	mA
Anode dissipation	175	235	248	W
Screen dissipation	30	30	22.5	W
Nominal driving power	2.9	3.8	4.2	W
Output power	575	800	1000	W
Efficiency	77	77	80	%

TYPICAL ANODE CHARACTERISTICS

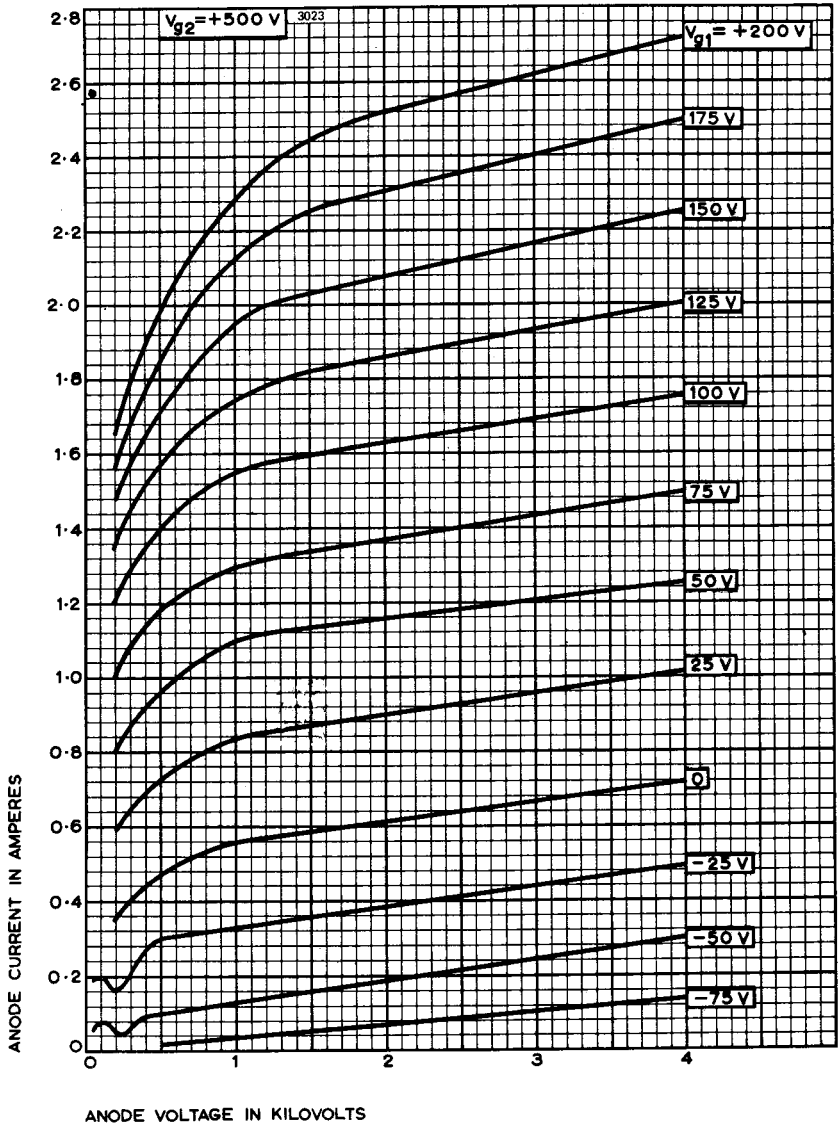

TYPICAL SCREEN CHARACTERISTICS

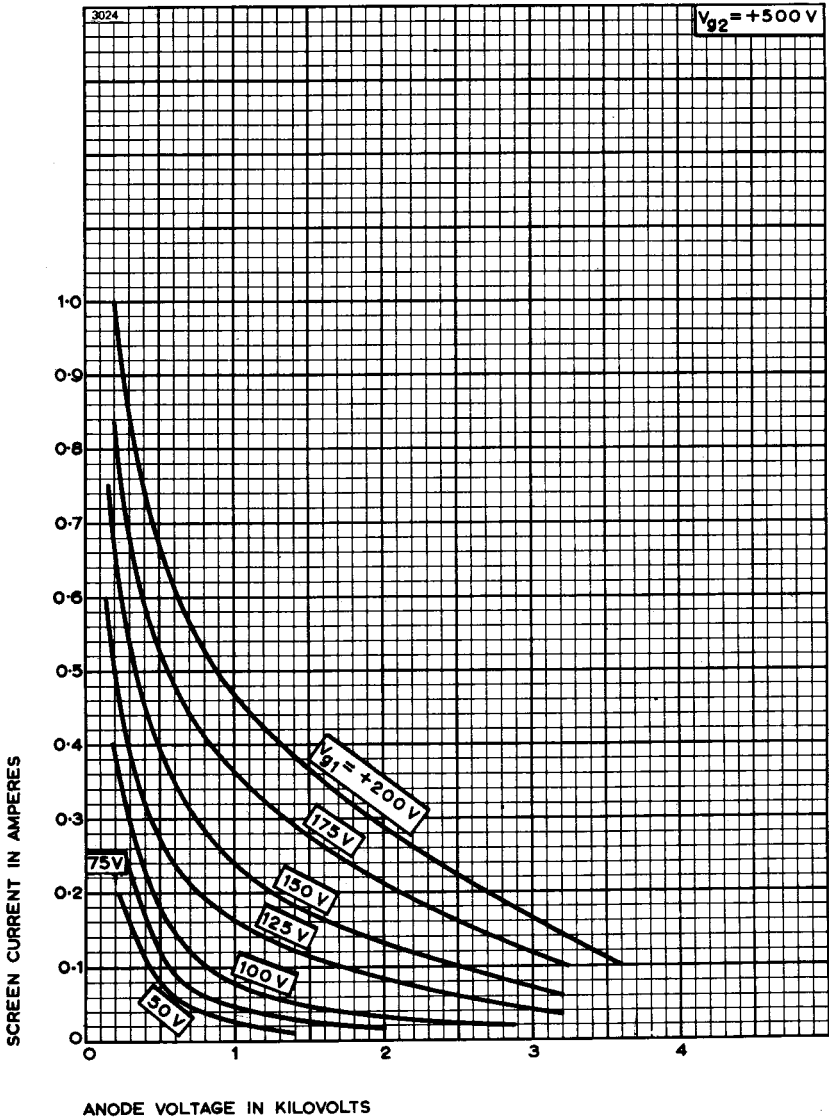

TYPICAL GRID CHARACTERISTICS

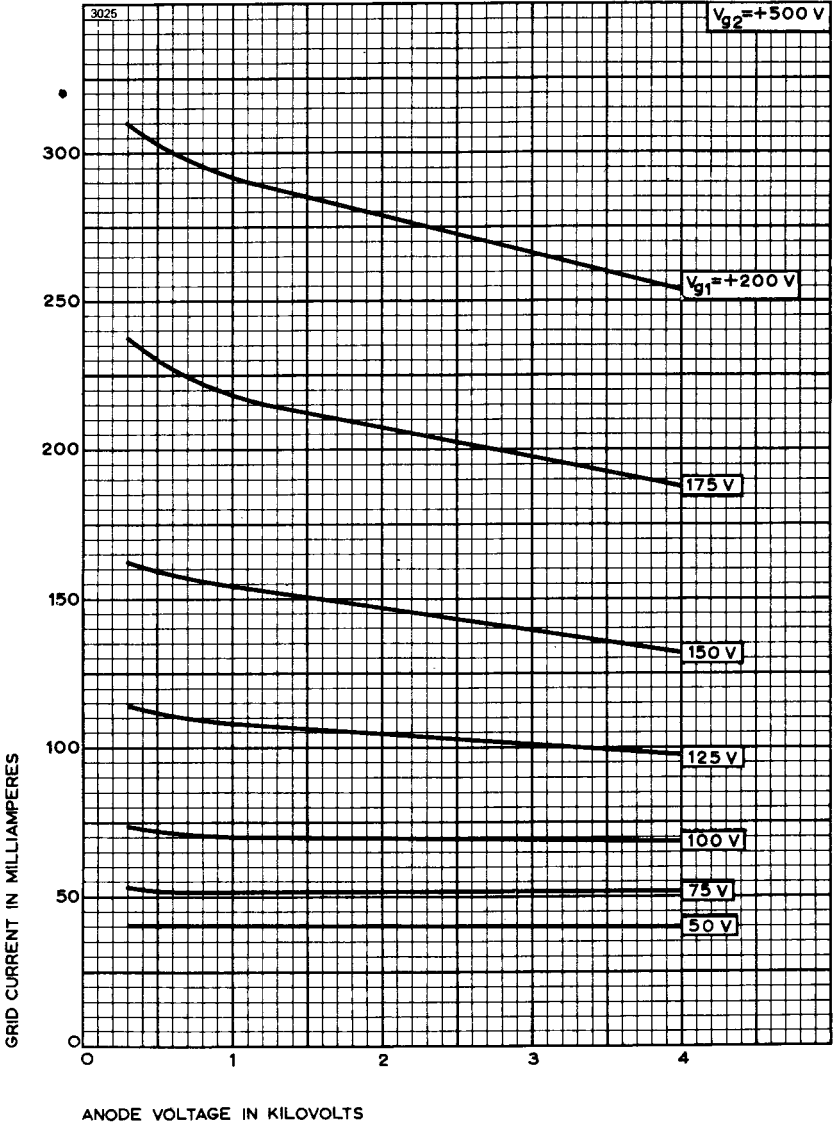

TYPICAL CONSTANT CURRENT CHARACTERISTICS

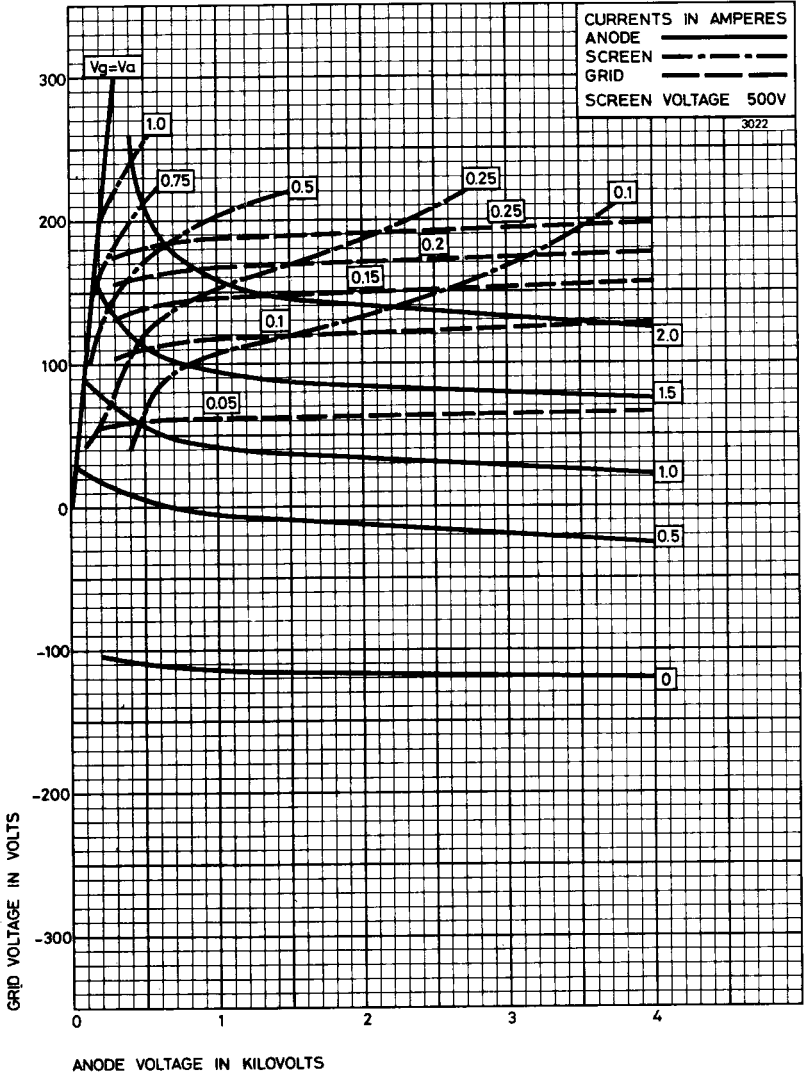

OUTLINE

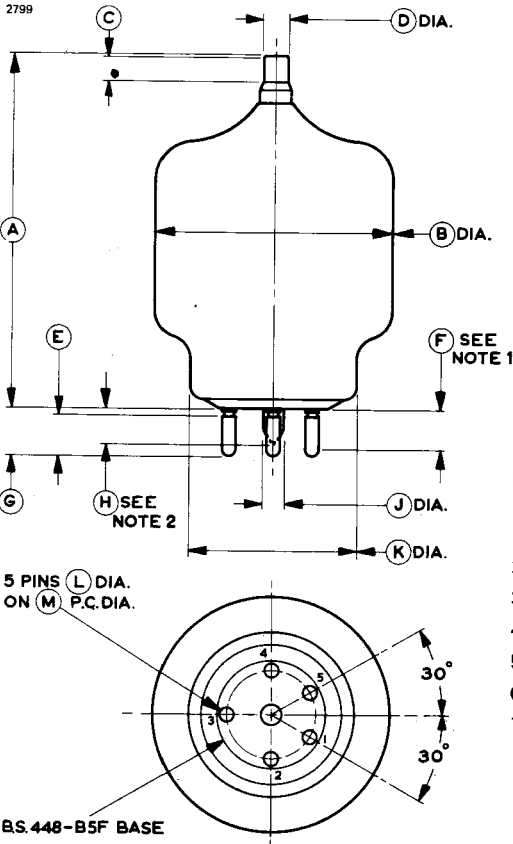

Outline Notes

1. Limit of parallel portion of pins.
2. Seal-off length.

Pin	Element
1	Filament
2	Screen
3	Grid
4	Screen
5	Filament
Cap	Anode

Ref	Millimetres	Inches	Ref	Millimetres	Inches
A	127.0 ± 6.0	5.000 ± 0.236	G	18.00 max	0.708 max
B	87.00 max	3.425 max	H	15.00 max	0.590 max
C	9.00 min	0.354 min	J	7.50 max	0.295 max
D	9.00 ± 0.13	0.354 ± 0.005	K	62.00 max	2.440 max
E	14.94 ± 0.25	0.588 ± 0.010	L	4.750 ± 0.076	0.187 ± 0.003
F	15.00 min	0.590 min	M	31.75	1.250

Inch dimensions have been derived from millimetres.



BEAM POWER DOUBLE TETRODE

Service Type CV2799

The data should be read in conjunction with the Power Tetrode Preamble.

ABRIDGED DATA

V.H.F. double tetrode, with centre-tapped heater for series or parallel operation.

Anode dissipation	2 x 10	W max
Anode voltage	600	V max
Frequency for full ratings	150	MHz max
Frequency at reduced ratings	600	MHz max
Output power (class C telegraphy, 2 sections in push-pull)	48	W

GENERAL

Electrical

Cathode	indirectly heated, oxide coated		
	Series	Parallel	
Heater voltage	12.6	6.3	V
Heater current	0.65	1.3	A
Grid-screen amplification factor (each unit) ($I_a = 20\text{mA}$)		8.0	
Mutual conductance (each unit) ($I_a = 20\text{mA}$)		2.5	mA/V
Inter-electrode capacitances (see note 1):			
grid to anode*		0.04	pF
input		7.5	pF
output		2.6	pF
input (two sections in push-pull)		4.4	pF
output (two sections in push-pull)		1.6	pF

* Internally neutralized for push-pull operation.

Mechanical

Overall length	86mm (3.38 inches) max
Overall diameter	46mm (1.81 inches) max
Net weight	2 ounces (60g) approx
Mounting position	vertical, base up or down
Horizontal operation is permitted with fixed station operation when the anode pins are in a horizontal plane.	
Base	B.S.448-B7A (JEDEC no. E7-2)

COOLING

The temperature of the seals must not exceed the values given below:

Anode seal or bulb temperature	200	°C max
Base pin seal temperature	180	°C max

A heat dissipating anode connector of large surface area or high heat conduction is necessary.

Natural cooling is normally sufficient at maximum ratings for frequencies up to 150MHz. At higher frequencies it may be necessary to direct an air flow of up to 5ft³/min (0.14m³/min) on to the anode and base seals.

AUDIO FREQUENCY POWER AMPLIFIER AND MODULATOR (Class B)

MAXIMUM RATINGS (Absolute values)

Anode voltage	600	V max
Anode dissipation	2 x 10	W max
Screen voltage	300	V max
Screen input power	2 x 1.5	W max
Grid voltage (negative value)	75	V max
Grid dissipation	2 x 0.5	W max
Grid resistor (fixed bias)	50	kΩ max
Grid resistor (cathode bias)	100	kΩ max
Cathode current (peak)	2 x 120	mA max
Cathode current (mean)	2 x 55	mA max
Peak heater to cathode voltage	100	V max

TYPICAL OPERATING CONDITIONS (Class B, 2 valves)

Anode voltage	300	500	V
Screen voltage	250	250	V
Grid voltage	-25	-26	V
Peak a.f. input voltage (grid to grid)	49	52	V
Effective load (anode to anode)	11	20	kΩ
Maximum-signal anode current	2 x 35	2 x 36.5	mA
Zero-signal anode current	2 x 12.5	2 x 12.5	mA
Maximum-signal screen current	2 x 9.5	2 x 8.1	mA
Zero-signal screen current	2 x 0.6	2 x 0.35	mA
Anode dissipation	2 x 3.9	2 x 6.5	W
Output power	13.2	23.5	W
Efficiency	63	64.5	%
Total distortion	3.5	3.5	%

PUSH-PULL R.F. POWER AMPLIFIER AND OSCILLATOR
(Class C telegraphy, key-down conditions, one valve)

MAXIMUM RATINGS (Absolute values)

Anode voltage	600	V max
Anode dissipation	2 x 10	W max
Screen voltage	300	V max
Screen input power	2 x 1.5	W max
Grid voltage (negative value)	75	V max
Grid current	2 x 2.5	mA max
Grid resistor (fixed bias)	50	k Ω max
Grid resistor (cathode bias)	100	k Ω max
Cathode current (mean)	2 x 55	mA max
Cathode current (peak)	2 x 260	mA max
Peak heater to cathode voltage	100	V max

TYPICAL OPERATING CONDITIONS

Frequency	200	200	200	200	MHz
Anode voltage	200	300	400	600	V
Screen voltage (see note 2)	200	250	250	250	V
Grid voltage	-30	-40	-50	-60	V
Anode current	2 x 50	2 x 50	2 x 50	2 x 50	mA
Screen current	2 x 4.0	2 x 4.5	2 x 4.0	2 x 4.0	mA
Grid current (approx)	2 x 1.0	2 x 0.7	2 x 0.7	2 x 0.7	mA
Driving power (approx)	<1.0	<1.0	1.0	1.5	W
Output power	13	21	30	48	W

Frequency	400	400	400	600	MHz
Anode voltage	200	300	400	400	V
Screen voltage (see note 2)	200	250	250	250	V
Grid voltage	-30	-40	-50	-50	V
Anode current	2 x 50	2 x 50	2 x 50	2 x 50	mA
Screen current	2 x 3.0	2 x 2.5	2 x 2.5	2 x 2.5	mA
Grid current (approx)	2 x 0.5	2 x 0.6	2 x 0.7	2 x 0.7	mA
Driving power (approx)	1.0	1.5	2.0	6.0	W
Output power	11	17	25	20	W

FREQUENCY TREBLER

TYPICAL OPERATING CONDITIONS

Output frequency	200	400 MHz
Anode voltage	300	300 V
Screen voltage	250	250 V
Grid voltage	-175	-175 V
Anode current	2 x 45	2 x 45 mA
Screen current	2 x 3.0	2 x 2.8 mA
Grid current (approx)	2 x 1.5	2 x 1.2 mA
Driving power (approx)	4.0	5.0 W
Output power	10	8.0 W

R.F. POWER AMPLIFIER – ANODE AND SCREEN MODULATED

(Class C telephony, carrier conditions per valve for use with a maximum modulation factor of 1.0)

MAXIMUM RATINGS (Absolute values)

Anode voltage	600	V max
Anode dissipation	2 x 6.7	W max
Screen voltage	300	V max
Screen input power	2 x 1.2	W max
Grid voltage (negative value)	100	V max
Grid current	2 x 2.5	mA max
Grid dissipation	2 x 0.5	W max
Cathode current (peak)	2 x 400	mA max
Cathode current (mean)	2 x 50	mA max
Peak heater to cathode voltage	100	V max

TYPICAL OPERATING CONDITIONS

Frequency	200	200	200	400 MHz
Anode voltage	300	500	600	300 V
Screen voltage	250	250	250	250 V
Grid voltage	-50	-80	-80	-50 V
Anode current	2 x 40	2 x 40	2 x 40	2 x 40 mA
Screen current	2 x 4.0	2 x 4.0	2 x 4.0	2 x 3.0 mA
Grid current (approx)	2 x 1.0	2 x 1.0	2 x 1.0	2 x 1.0 mA
Driving power (approx)	1.5	3.0	3.0	2.5 W
Anode dissipation	2 x 3.5	2 x 4.0	2 x 5.0	2 x 4.5 W
Output power	17	31	38	15 W
Efficiency	71	78	79	63 %

MAXIMUM ANODE VOLTAGE AGAINST FREQUENCY

Natural Cooling

Operating frequency (MHz)	Max. anode voltage c.w. (V)	Max. anode voltage with anode modulation (V)
150	600	600
200	500	500
450	300	300
600	250	250

Forced-air Cooling

Operating frequency (MHz)	Max. anode voltage c.w. (V)	Max. anode voltage with anode modulation (V)
250		600
300	600	
600	400	400

NOTES

1. Inter-electrode capacitances are for each unit except where otherwise indicated.
2. The screen voltage may be obtained from a separate source, or from the anode supply with a potential divider or through a series resistor. The screen voltage must not exceed 600V under key-up conditions.

TYPICAL ANODE CHARACTERISTICS

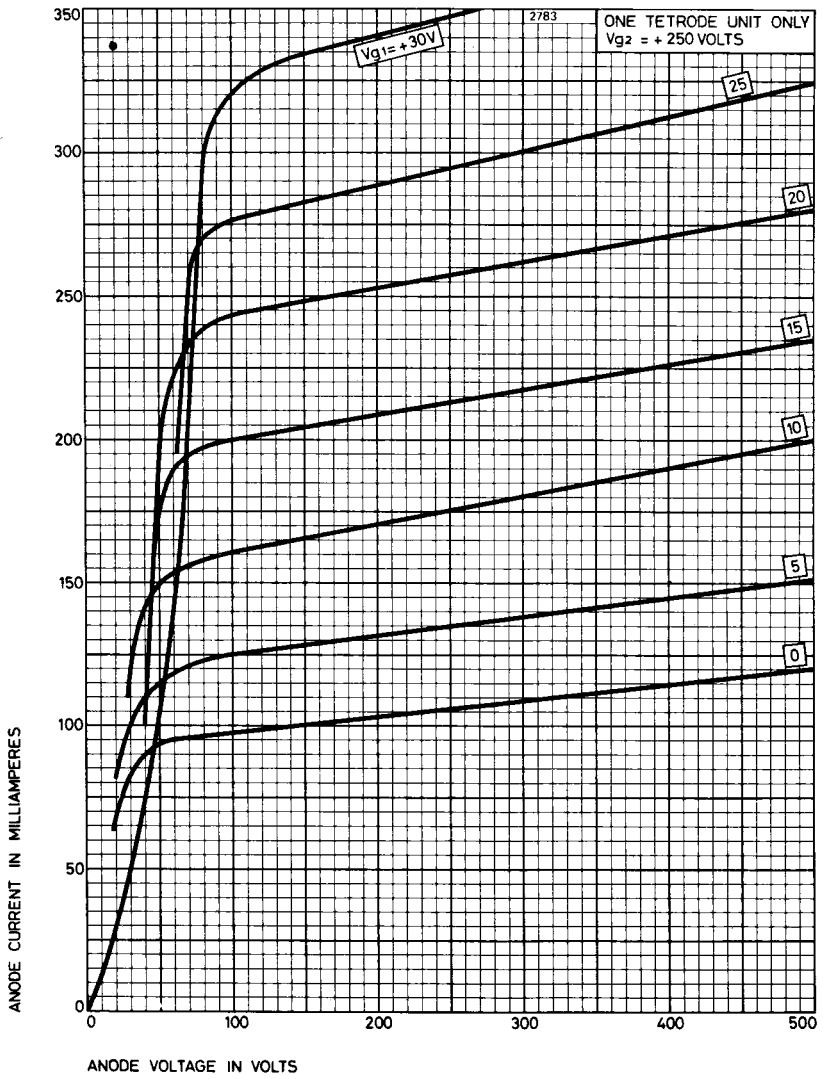

TYPICAL ANODE CHARACTERISTICS

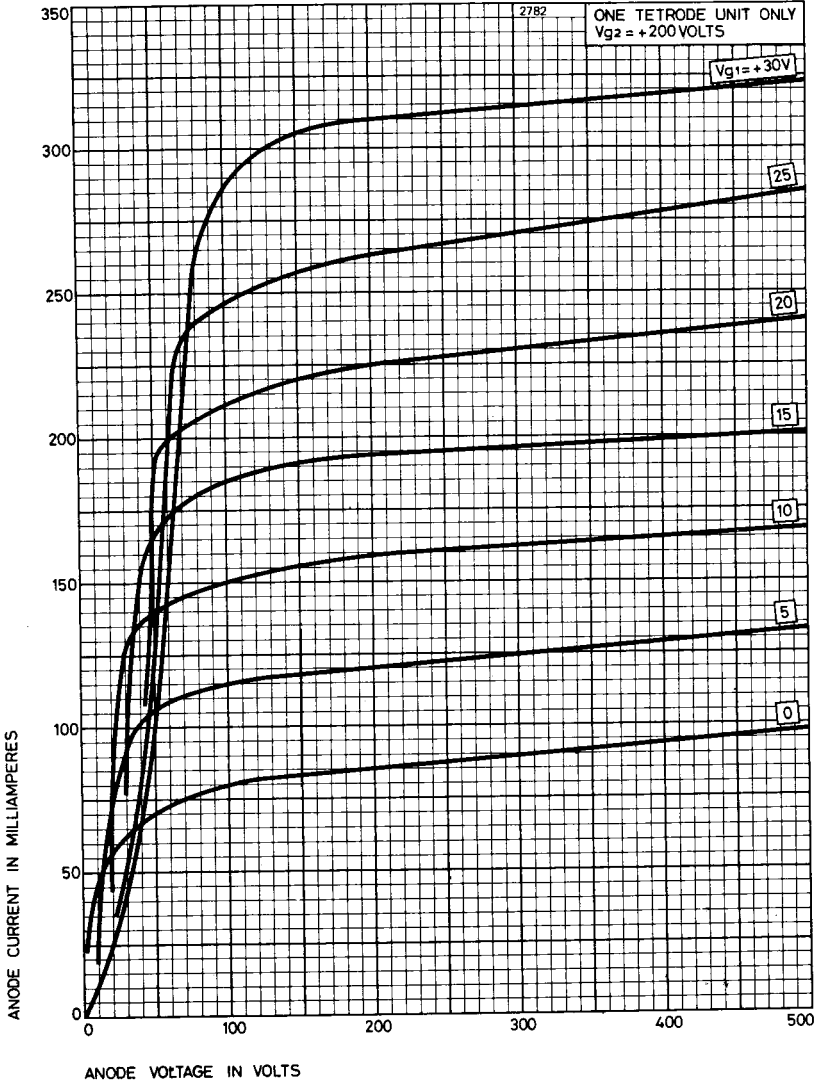

TYPICAL SCREEN CHARACTERISTICS

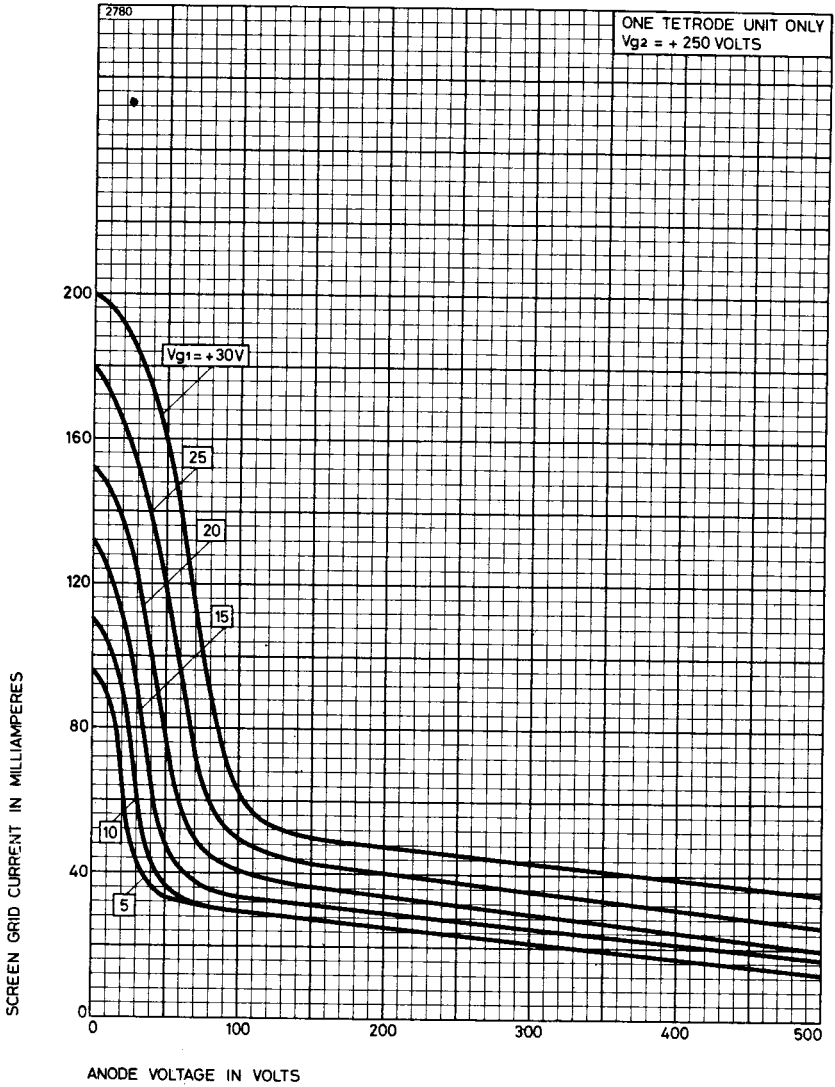

TYPICAL SCREEN CHARACTERISTICS

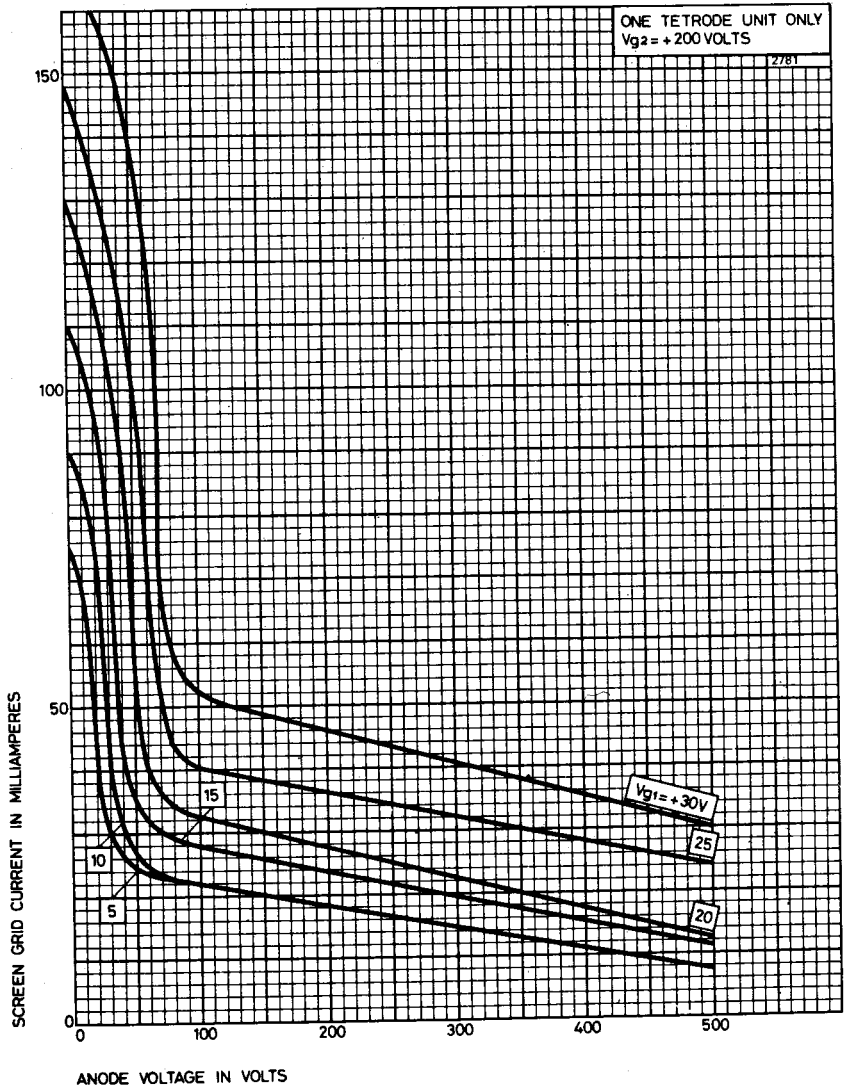

TYPICAL GRID CHARACTERISTICS

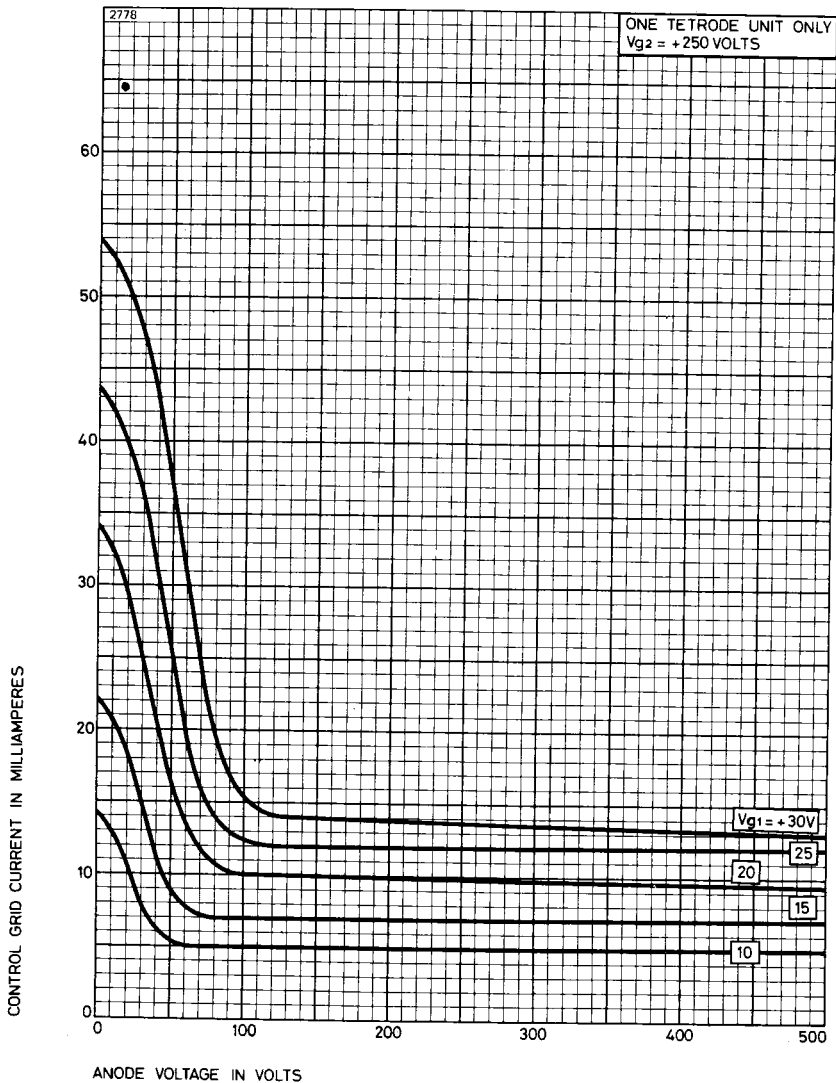

TYPICAL GRID CHARACTERISTICS

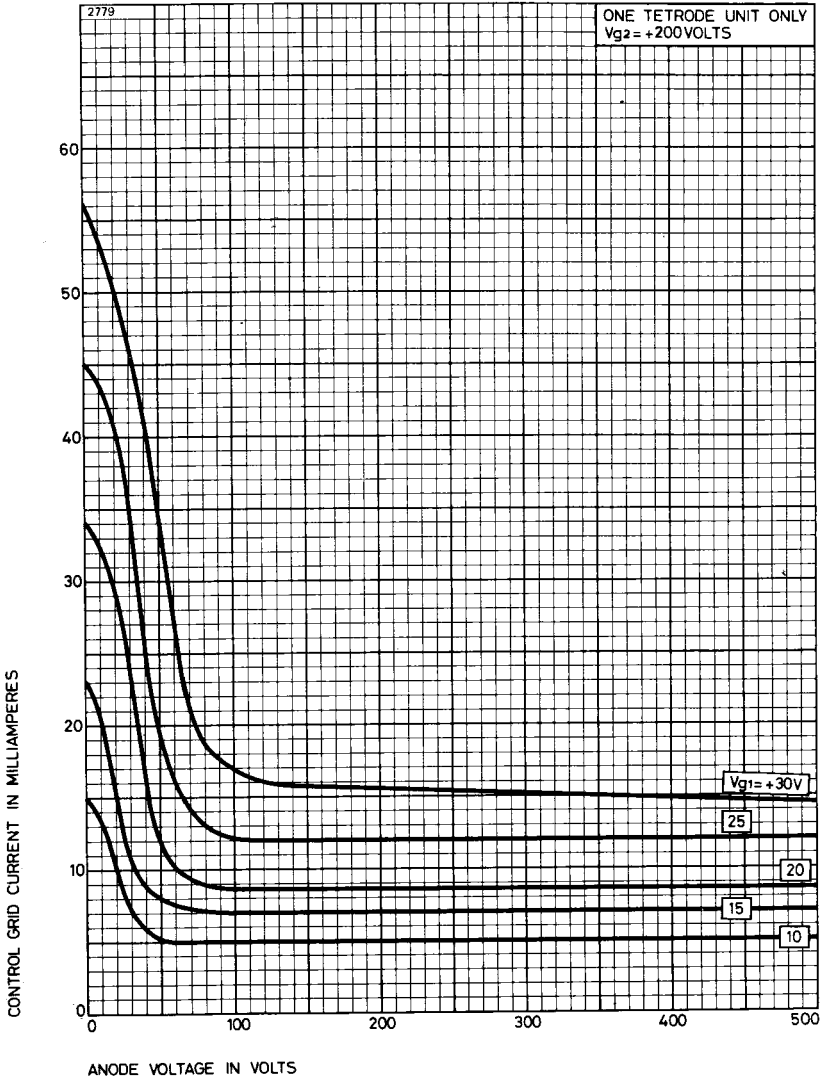

TYPICAL CONSTANT CURRENT CHARACTERISTICS

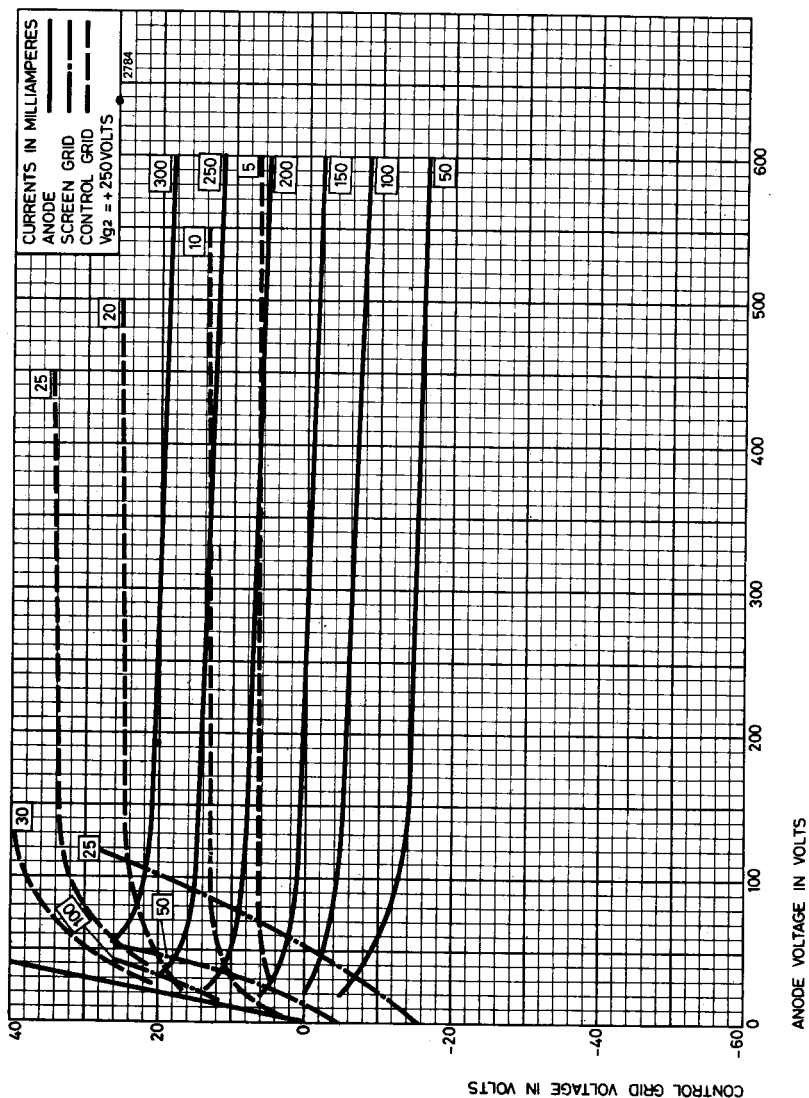

TYPICAL CONSTANT CURRENT CHARACTERISTICS

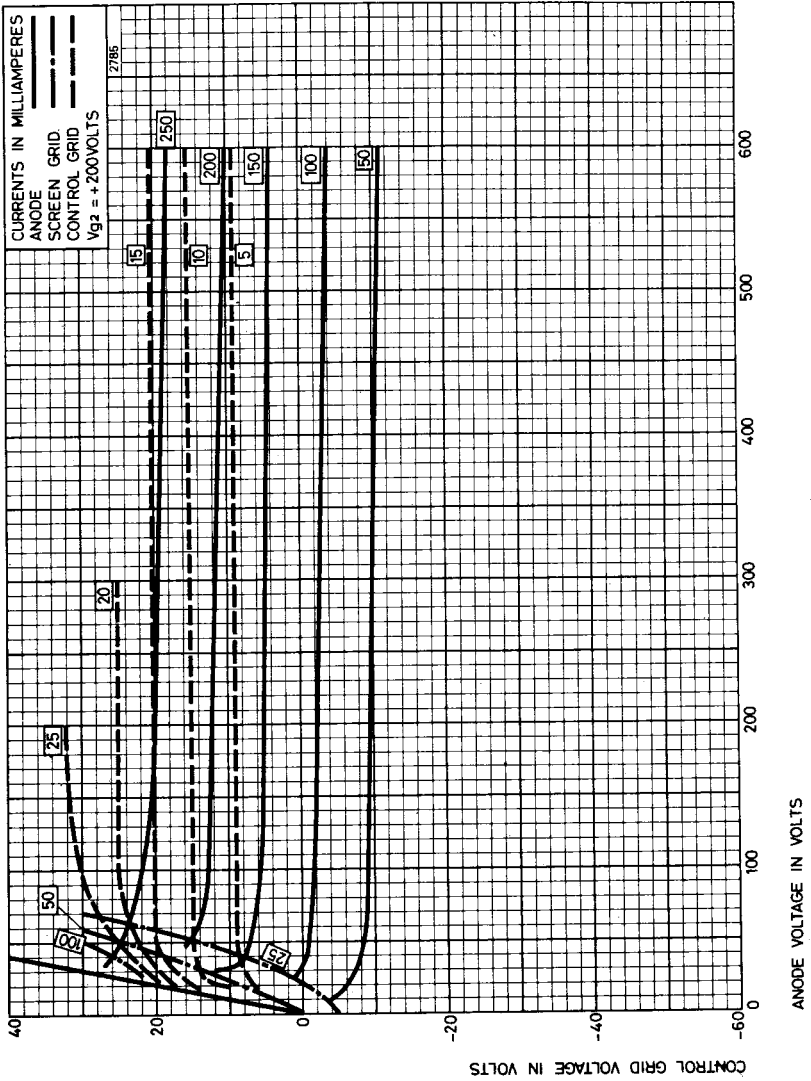

OUTLINE (All dimensions without limits are nominal)

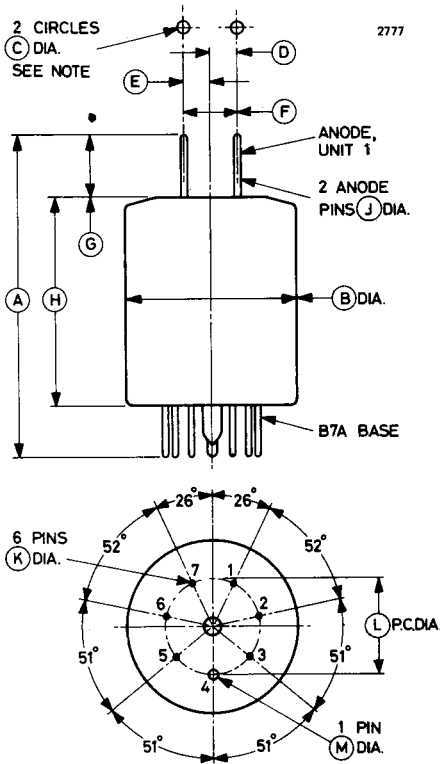

2777

Pin	Element
1	Heater
2	Grid, unit 1
3	Screen, common
4	Cathode, beam plates, shield
5	Heater centre tap
6	Grid, unit 2
7	Heater

Note The location of the anode pins will be within the two circles.

Ref	Millimetres	Inches	Ref	Millimetres	Inches
A	85.5 max	3.366 max	H	55.0 max	2.165 max
B	46.0 max	1.811 max	J	2.0	0.079
C	3.6	0.142	K*	1.473 + 0.051 - 0.152	0.058 + 0.002 - 0.006
D	7.0	0.276	L*	25.4	1.000
E	7.0	0.276	M*	3.175 ± 0.076	0.125 ± 0.003
F	14.0 ± 1.0	0.550 ± 0.040			
G	16.5 ± 1.5	0.650 ± 0.059			

Inch dimensions have been derived from millimetres except where marked *

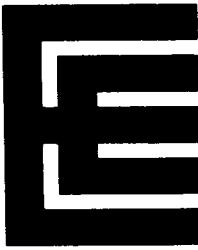

R.F. POWER TETRODE

Service Type CV5959

The data should be read in conjunction with the Power Tetrode Preamble.

ABRIDGED DATA

V.H.F. radial beam tetrode for amplifier, oscillator or modulator applications.

Anode dissipation	400	W max
Anode voltage	4.0	kV max
Frequency for full ratings	110	MHz max
Output power (class C unmodulated conditions)	1.1	kW

GENERAL

Electrical

Filament	thoriated tungsten
Filament voltage	5.0 V
Filament current	14.5 A
Peak usable cathode current	2.2 A
Perveance	0.65 mA/V ^{3/2}
Grid-screen amplification factor (V _a = 2.5kV, V _{g2} = 500V, I _a = 100mA)	5.1
Mutual conductance (V _a = 2.5kV, V _{g2} = 500V, I _a = 100mA)	4.0 mA/V
Inter-electrode capacitances:	
input	12.7 pF
output	4.9 pF
grid to anode	0.12 pF

Mechanical

Overall length	151mm (5.944 inches) max
Overall diameter	87mm (3.425 inches) max
Net weight	230g (8 ounces) approx
Mounting position	vertical, base up or down
Base	B.S.448-B5F

COOLING

An adequate flow of air must be provided to maintain the temperatures of the glass to metal seals and the envelope below the maximum values given below.

Where the anode dissipation is less than 250W, an air flow of at least 5ft³/min (0.14m³/min) should be directed at the valve base. Up to 14ft³/min (0.4m³/min) will be required when the anode dissipation exceeds 150W and a glass chimney should be used in order to assist circulation.

Anode seal temperature	220	°C max
Base pin seal temperature	180	°C max
Bulb temperature	350	°C max

A heat dissipating anode connector of large surface area is necessary.

AUDIO FREQUENCY POWER AMPLIFIER OR MODULATOR (Class AB)

MAXIMUM RATINGS (Absolute values)

Anode voltage	4.0	kV max
Anode dissipation	400	W max
Screen voltage	800	V max
Screen dissipation	35	W max
Grid voltage (negative value)	500	V max
Grid dissipation	10	W max
Grid to filament resistance	250	kΩ max
Cathode current (mean)	400	mA max

TYPICAL OPERATING CONDITIONS

(Class AB without grid current, 2 valves)

Anode voltage	3.0	3.5	4.0	kV
Screen voltage	750	750	750	V
Grid voltage	-137	-145	-150	V
Peak a.f. input voltage (grid to grid)	275	290	300	V
Maximum-signal anode current	2 x 318	2 x 305	2 x 292	mA
Zero-signal anode current	2 x 80	2 x 70	2 x 60	mA
Maximum-signal screen current	2 x 13	2 x 16	2 x 20	mA
Effective load (anode to anode)	8.9	11.5	14.5	kΩ
Anode dissipation	2 x 400	2 x 400	2 x 400	W
Output power	1.11	1.33	1.54	kW
Efficiency	58	62	66	%

Continued on page 3

TYPICAL OPERATING CONDITIONS (Class AB with grid current, 2 valves)

Anode voltage	3.0	3.5	4.0	kV
Screen voltage	500	500	500	V
Grid voltage	-80	-85	-90	V
Peak a.f. input voltage (grid to grid)	290	304	304	V
Maximum-signal anode current	2 x 350	2 x 350	2 x 319	mA
Zero-signal anode current	2 x 90	2 x 80	2 x 80	mA
Maximum-signal screen current	2 x 20	2 x 19	2 x 16	mA
Grid current	2 x 3.0	2 x 3.0	2 x 3.0	mA
Effective load (anode to anode)	10	11.3	15	k Ω
Anode dissipation	2 x 362	2 x 400	2 x 400	W
Nominal driving power	2 x 4.5	2 x 5.0	2 x 3.5	W
Output power	1.375	1.65	1.75	kW
Efficiency	65	67	69	%

ANODE AND SCREEN MODULATED R.F. POWER AMPLIFIER

(Class C telephony, carrier conditions per valve for use with a maximum modulation factor of 1.0)

MAXIMUM RATINGS (Absolute values)

Anode voltage	3.2	kV max
Anode dissipation	270	W max
Screen voltage	600	V max
Screen dissipation	35	W max
Grid voltage (negative value)	500	V max
Grid dissipation	10	W max
Grid to filament resistance	50	k Ω max
Cathode current (mean)	330	mA max
Frequency for above ratings	75	MHz max

TYPICAL OPERATING CONDITIONS (for frequencies up to 75MHz)

Anode voltage	2.0	2.5	3.0	kV
Screen voltage	500	500	500	V
Grid voltage	-220	-220	-220	V
Peak r.f. grid voltage	305	305	305	V
Peak screen modulating voltage (modulation factor 1.0)	400	400	400	V
Anode current	275	275	275	mA
Screen current	30	28	26	mA
Grid current	6.0	6.0	6.0	mA
Anode dissipation	170	178	195	W
Screen dissipation	15	14	13	W
Nominal driving power	3.5	3.5	3.5	W
Output power	380	510	630	W
Efficiency	69	74	76	%

R.F. POWER AMPLIFIER OR OSCILLATOR
(Class C telegraphy, key-down conditions, one valve)

MAXIMUM RATINGS (Absolute values)

Anode voltage	4.0	kV max
Anode dissipation	400	W max
Screen voltage	600	V max
Screen dissipation	35	W max
Grid voltage (negative value)	500	V max
Grid dissipation	10	W max
Grid to filament resistance	50	k Ω max
Cathode current (mean)	420	mA max
Frequency for above ratings	110	MHz max

TYPICAL OPERATING CONDITIONS

Frequency	<75	<75	<75	MHz
Anode voltage	2.5	3.0	4.0	kV
Screen voltage	500	500	500	V
Grid voltage	-200	-220	-220	V
Peak r.f. grid voltage	290	305	305	V
Anode current	350	350	350	mA
Screen current	46	46	40	mA
Grid current	6.5	6.0	6.0	mA
Anode dissipation	235	250	300	W
Screen dissipation	17.5	15	12.5	W
Nominal driving power	12	12	12	W
Output power	640	800	1100	W
Efficiency	73	76	79	%

TYPICAL OPERATING CONDITIONS

Frequency	100	100	MHz
Anode voltage	3.5	4.0	kV
Screen voltage	500	500	V
Grid voltage	-170	-170	V
Peak r.f. grid voltage	235	240	V
Anode current	250	270	mA
Screen current	17	15.5	mA
Grid current	9.0	10	mA
Anode dissipation	225	280	W
Screen dissipation	30	30	W
Nominal driving power	20	20	W
Output power	650	800	W
Efficiency	74	74	%

TYPICAL ANODE CHARACTERISTICS

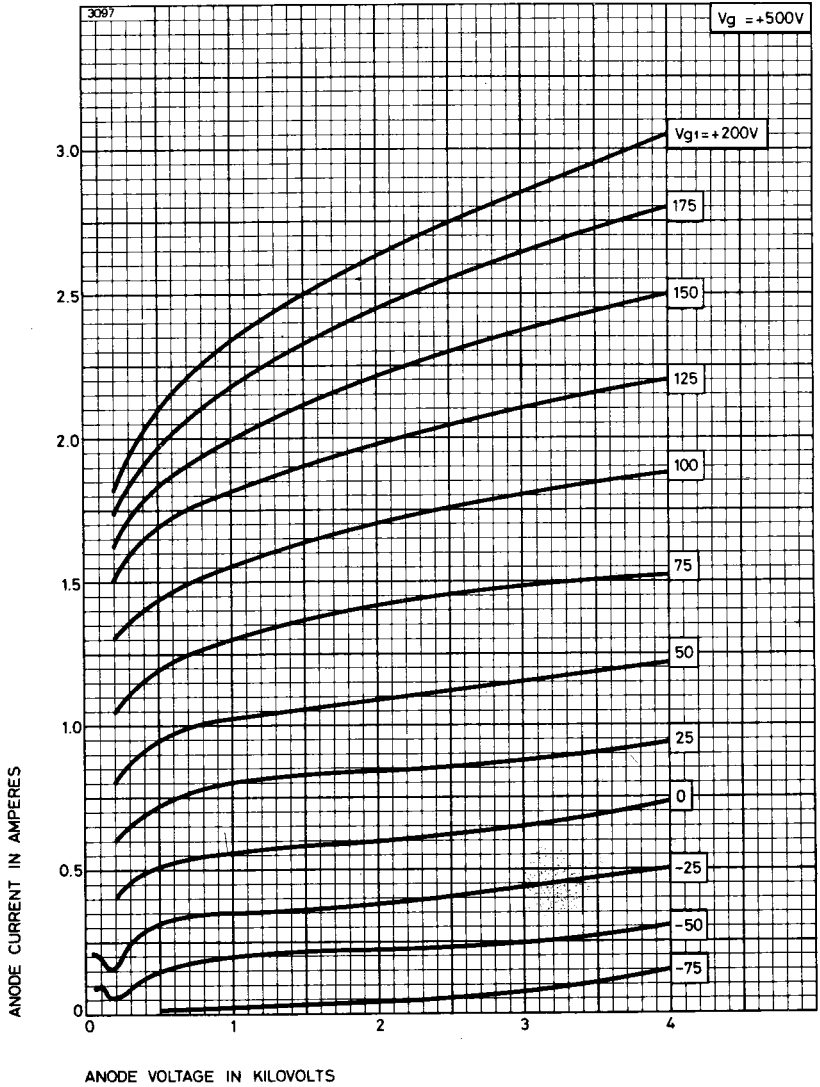

TYPICAL SCREEN CHARACTERISTICS

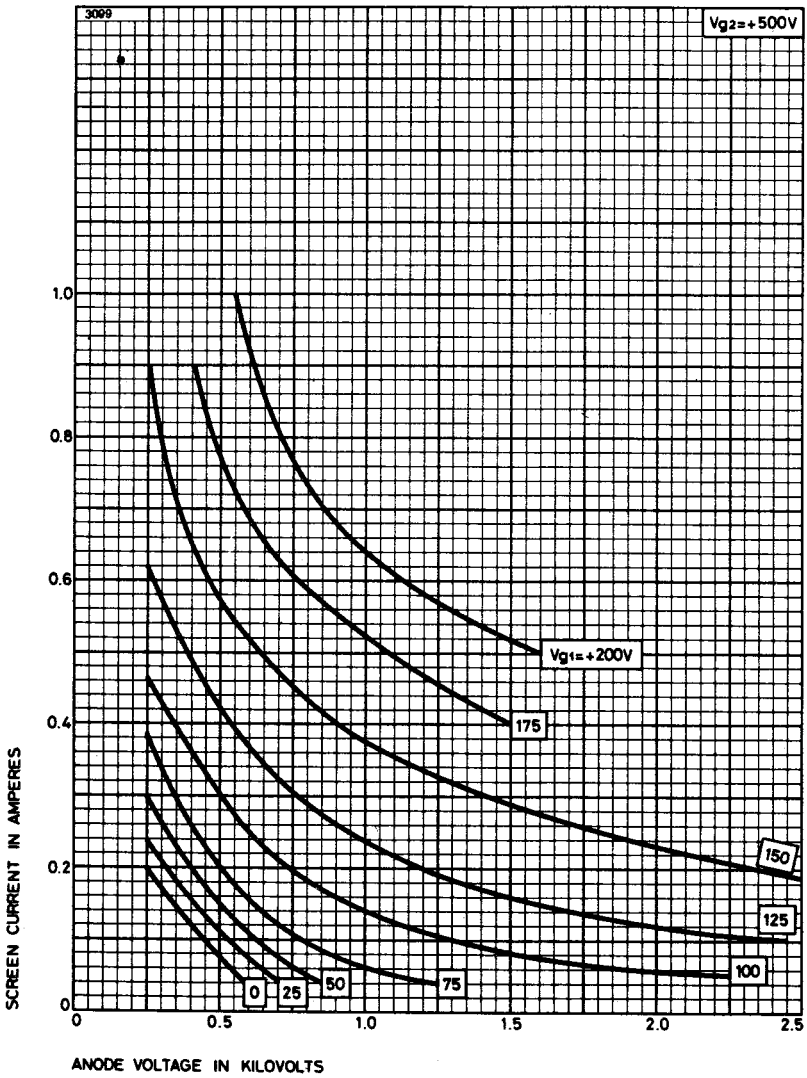

TYPICAL GRID CHARACTERISTICS

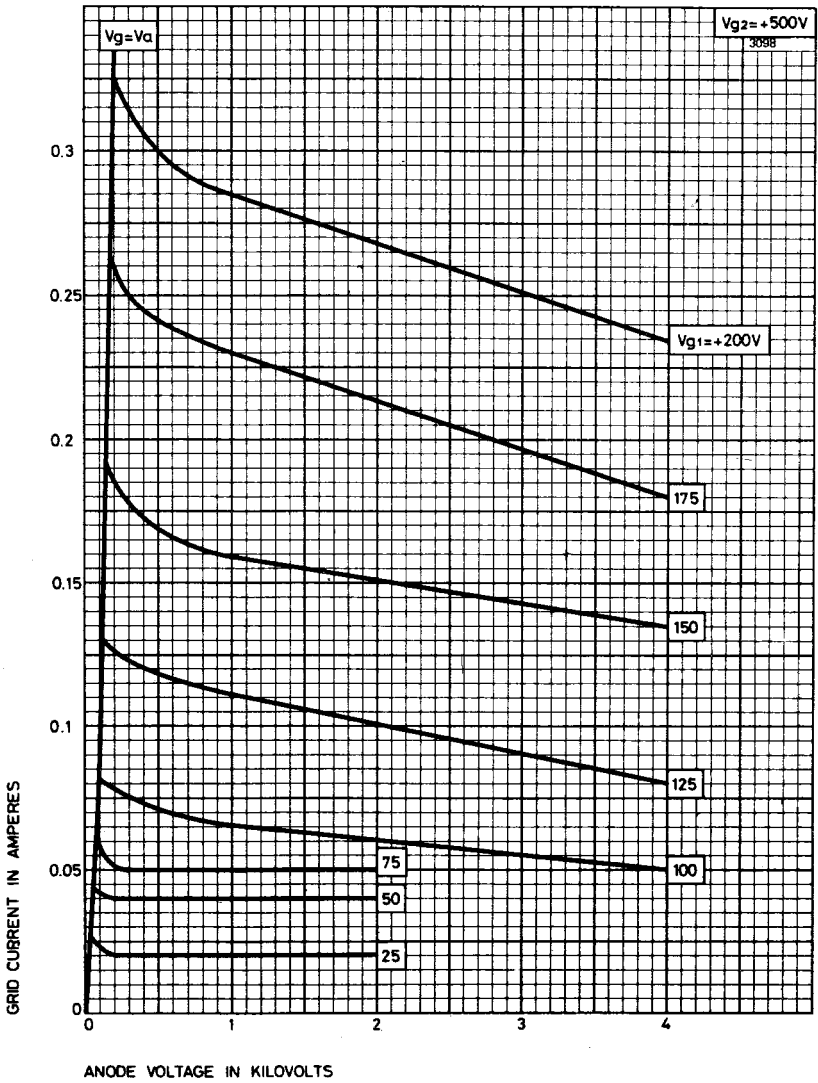

TYPICAL CONSTANT CURRENT CHARACTERISTICS

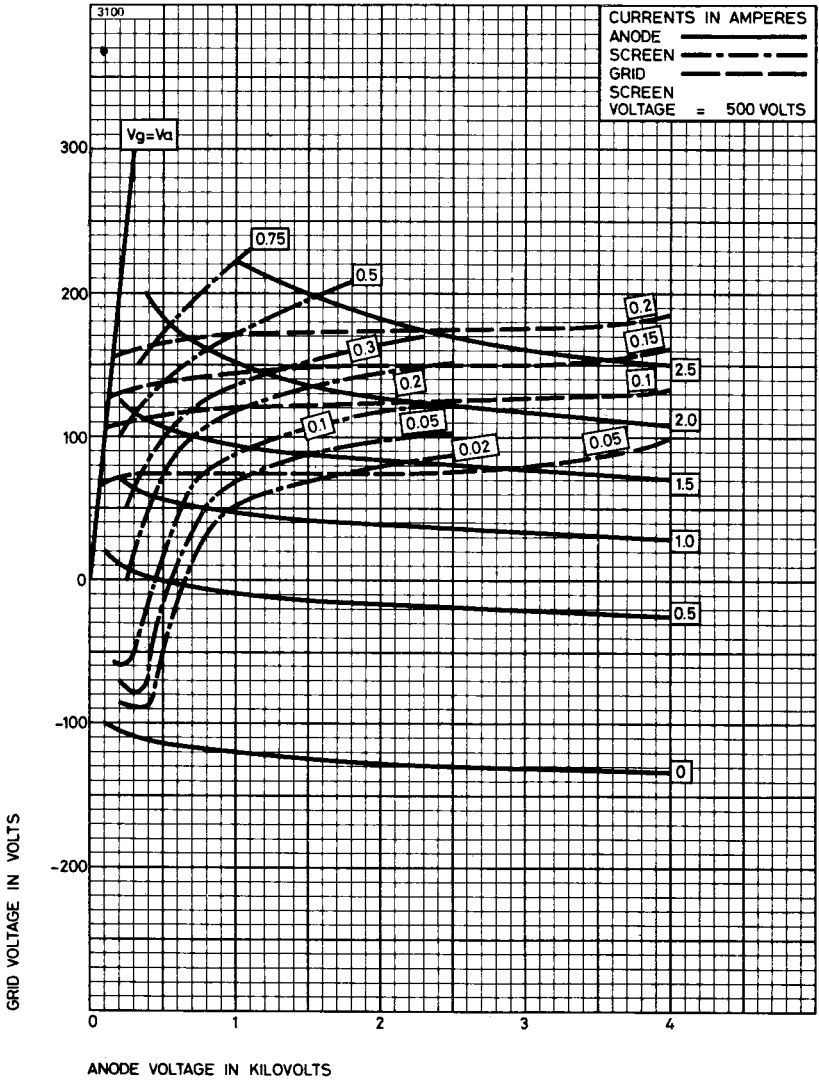

OUTLINE

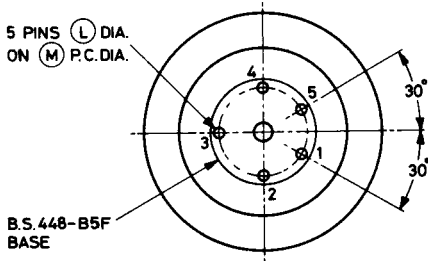
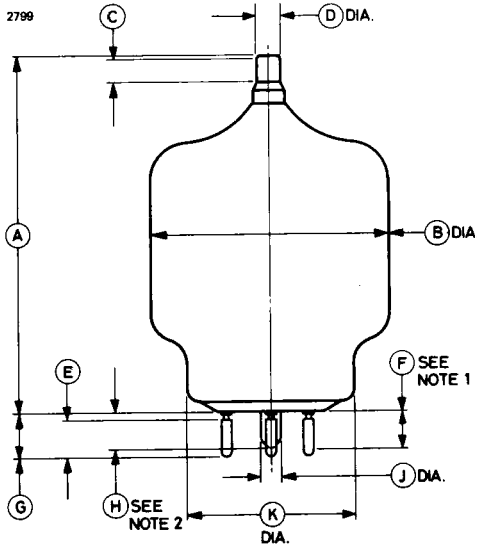

Outline Notes

1. Limit of parallel portion of pins.
2. Seal-off length.

Pin	Element
1	Filament
2	Screen
3	Grid
4	Screen
5	Filament
Cap	Anode

Ref	Millimetres	Inches	Ref	Millimetres	Inches
A	127.0 ± 6.0	5.000 ± 0.236	G	18.00 max	0.708 max
B	87.00 max	3.425 max	H	15.00 max	0.590 max
C	9.00 min	0.354 min	J	7.50 max	0.295 max
D	9.00 ± 0.13	0.354 ± 0.005	K	62.00 max	2.440 max
E	14.94 ± 0.25	0.588 ± 0.010	L	4.750 ± 0.076	0.187 ± 0.003
F	15.00 min	0.590 min	M	31.75	1.250

Inch dimensions have been derived from millimetres.



POWER TETRODE

Service Type CV6045

The data should be read in conjunction with the Power Tetrode Preamble.

DESCRIPTION

The C1158 is a low impedance beam tetrode intended for use in d.c. control equipment. It may be triode connected and is suitable for pulse operation.

GENERAL DATA

Electrical

Cathode	indirectly heated, oxide coated		
	Parallel	Series	
Heater voltage	13	26	V
Heater current	2.6	1.3	A
Mutual conductance (triode connected) ($V_a = 150V, I_a = 0.5A$)	35		mA/V
Amplification factor (triode connected) ($V_a = 150V, I_a = 0.5A$)	4.5		
Anode resistance (triode connected) ($V_a = 150V, I_a = 0.5A$)	130		Ω
Inter-electrode capacitances:			
grid to anode	1.3		pF
input	56		pF
output	20.4		pF

Mechanical

Overall length	5.395 inches (137mm) max
Overall diameter	2.560 inches (65mm) nom
Net weight	6 ounces (170g) approx
Base	B.S.448-B7A
Mounting position	vertical

COOLING

Natural cooling is normally adequate but the bulb and base temperatures must not exceed the values given below.

Bulb temperature	200	$^{\circ}C$
Base temperature	150	$^{\circ}C$

MAXIMUM RATINGS (Absolute values)

D.C. Ratings

Anode voltage	800	V max
Anode dissipation	90	W max
Anode and screen dissipation (triode connected)	95	W max
Screen voltage	300	V max
Screen dissipation	10	W max
Grid voltage (negative)	100	V max
Grid dissipation	1.0	W max
Cathode current	800	mA max
Heater to cathode voltage (heater negative)	300	V max

Pulse Ratings

Anode voltage (peak)	1500	V max
Cathode current (peak)	5.0	A max
Duty cycle (averaging time 100 μ s)	0.05	max
Product of peak current and pulse length (for peak currents exceeding 2.0A)	10	A $\cdot\mu$ s max

TYPICAL ANODE CURRENT – ANODE VOLTAGE CHARACTERISTICS

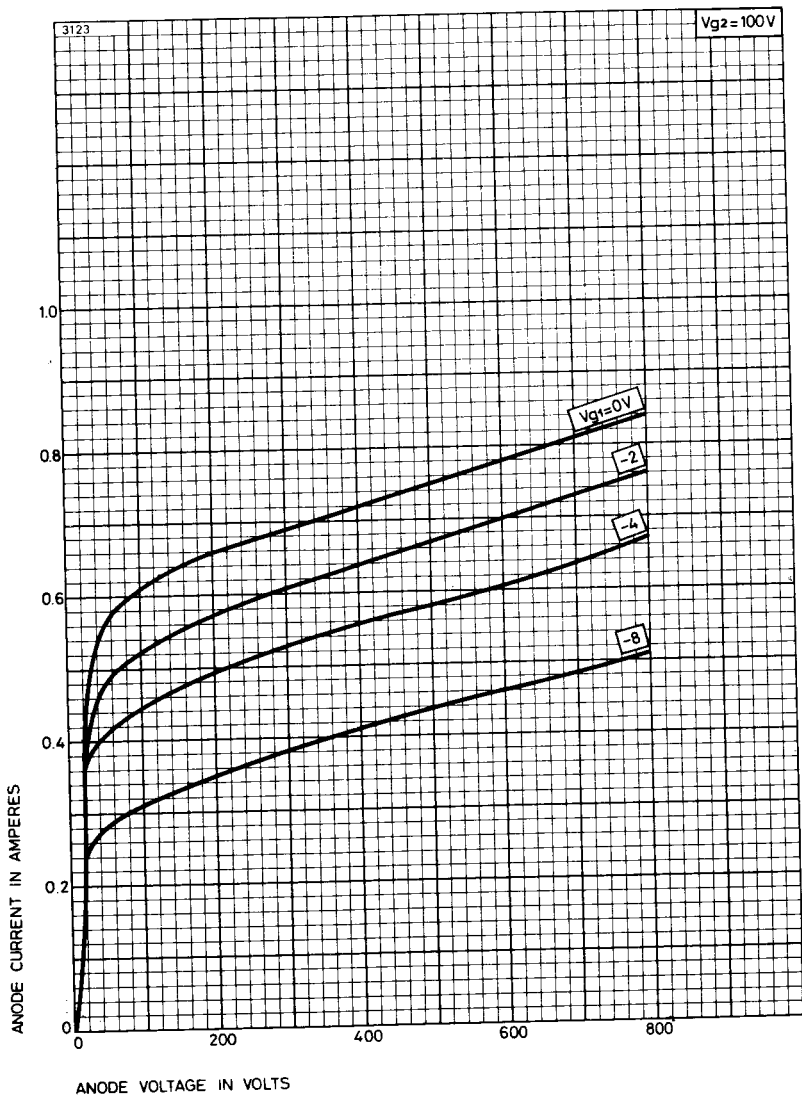

TYPICAL SCREEN CURRENT – ANODE VOLTAGE CHARACTERISTICS

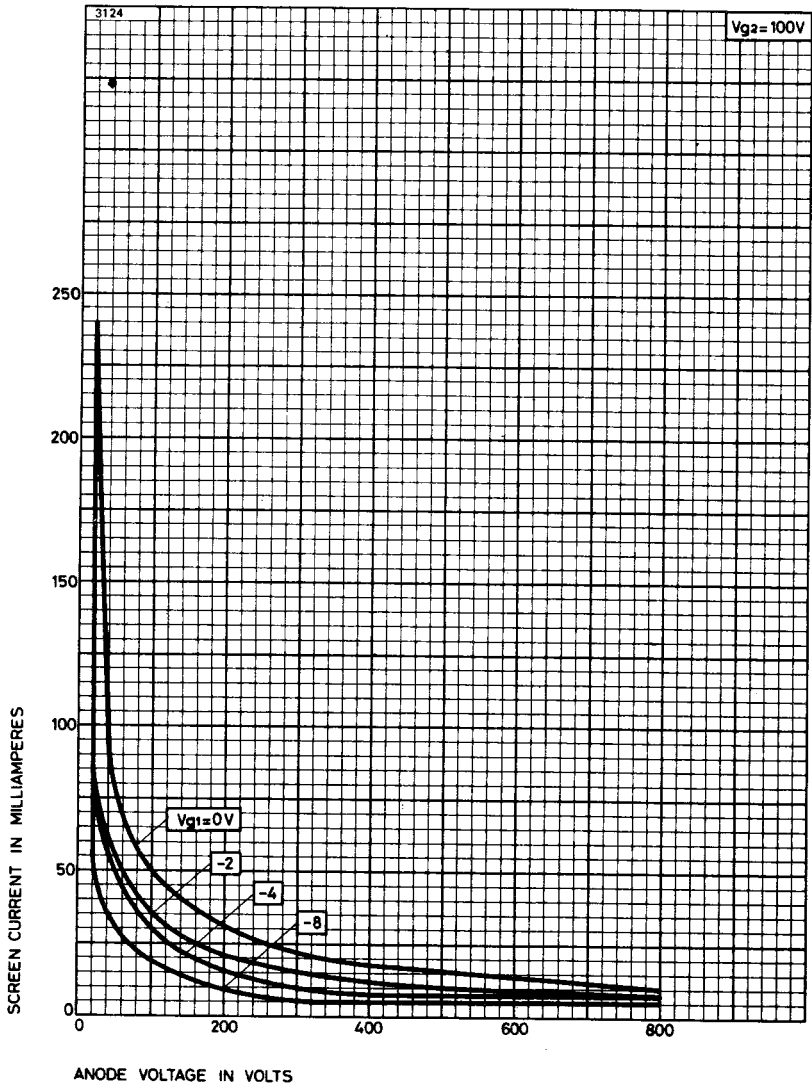

TYPICAL ANODE CURRENT – GRID VOLTAGE CHARACTERISTICS

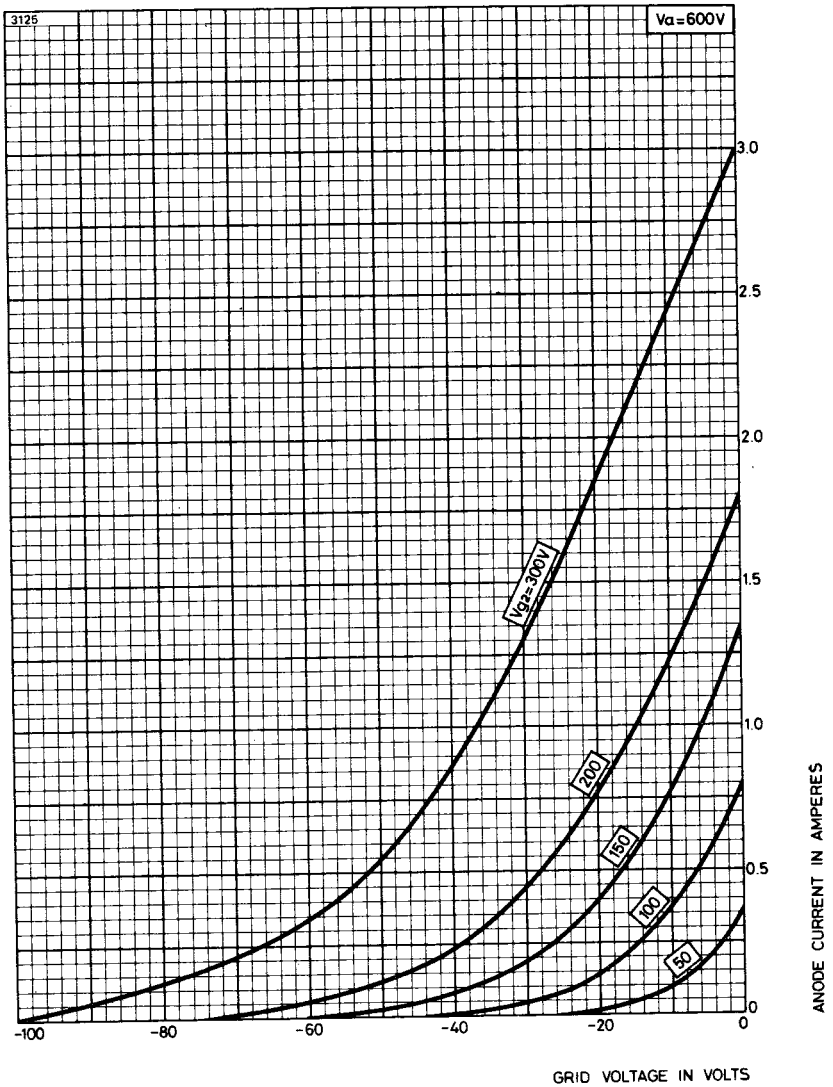

TYPICAL SCREEN CURRENT – GRID VOLTAGE CHARACTERISTICS

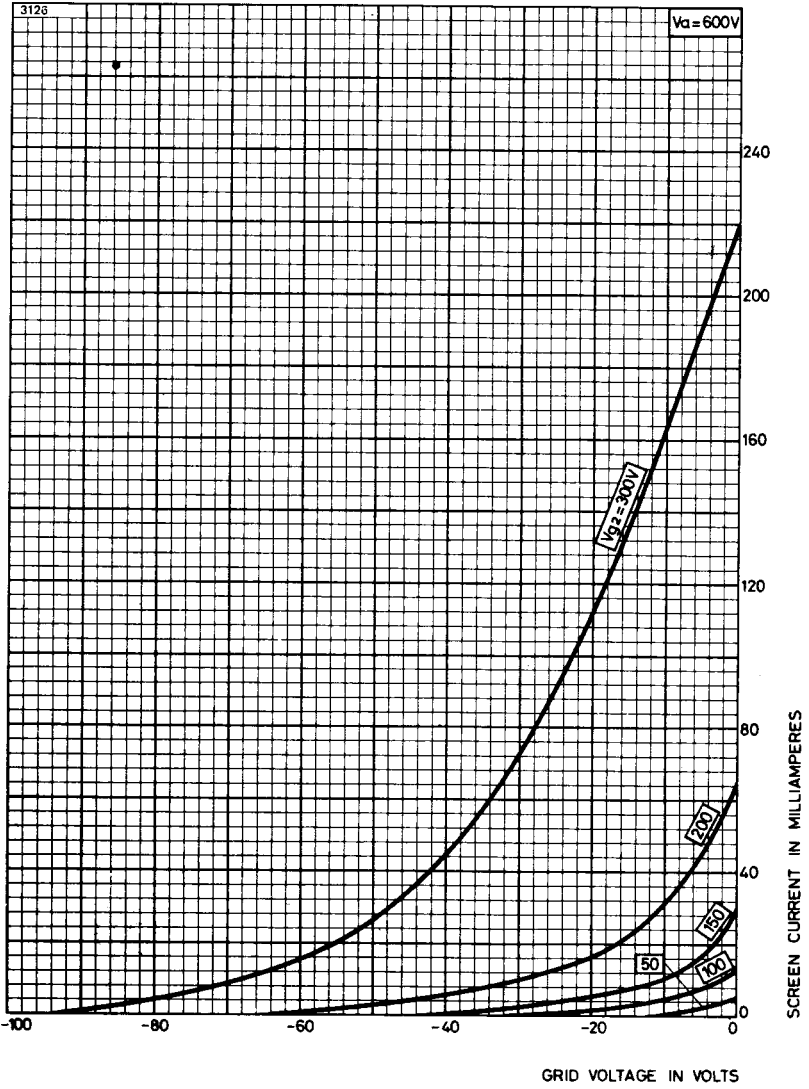

TYPICAL TRIODE CHARACTERISTICS

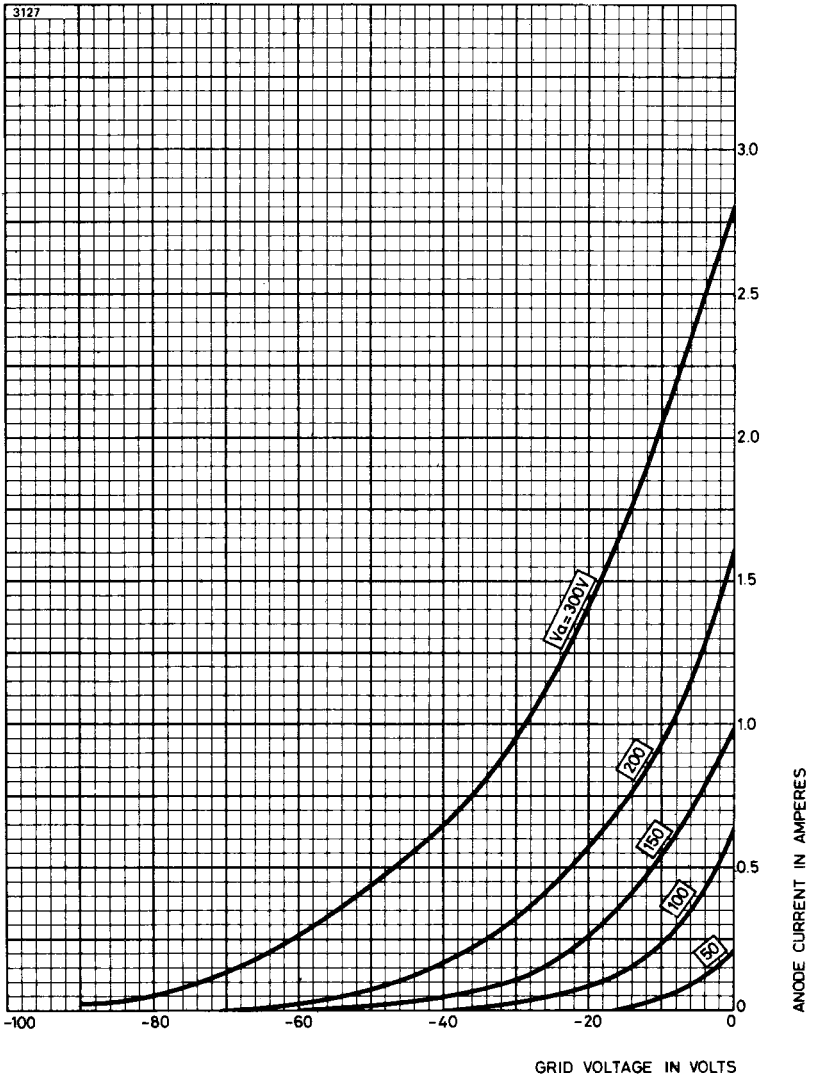

OUTLINE (All dimensions without limits are nominal)

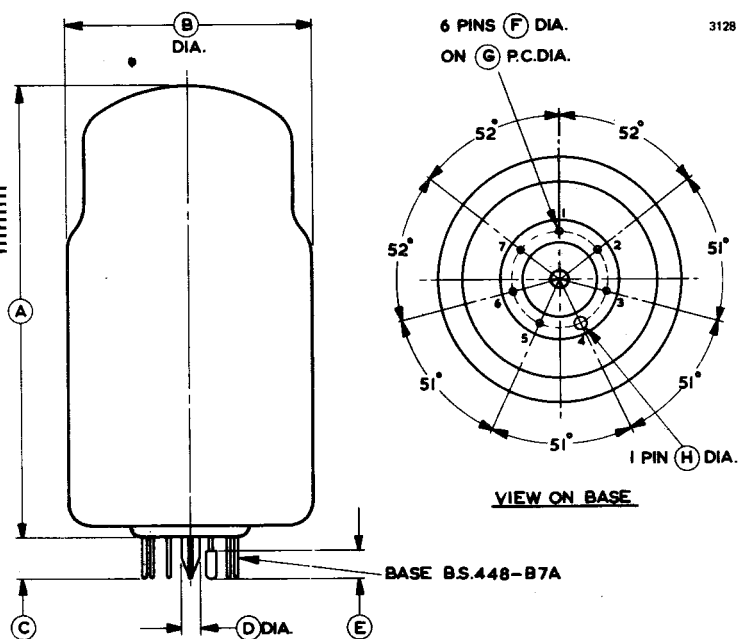

Ref	Inches	Millimetres
A*	4.724	120.0
B*	2.560	65.00
C	0.437 ± 0.062	11.10 ± 1.58
D	$\varnothing.276$ max	7.01 max
E	0.312	7.93
F	0.060	1.52
G	1.000	25.40
H	0.125	3.18

Pin	Element
1	Heater
2	Heater centre tap
3	Grid
4	Cathode
5	Screen
6	Anode
7	Heater

Millimetre dimensions have been derived from inches except where indicated thus *.

High Power Tetrodes





4CW10,000A

R.F. POWER TETRODE

The data should be read in conjunction with the Power Tetrode Preamble.

ABRIDGED DATA

Water cooled tetrode with integral water jacket and coaxial metal-ceramic envelope, for audio, linear single sideband, or screen-modulated r.f. amplifiers.

Anode dissipation (class C telegraphy)	10	kW max
Anode voltage	7.5	kV max
Frequency for full ratings	30	MHz max
Frequency at reduced ratings	110	MHz max
Output power (class C telegraphy)	16	kW



GENERAL

Electrical

Filament	thoriated tungsten	
Filament voltage (see note 1)	7.5	V
Filament current	75	A
Grid-screen amplification factor ($V_a = 2.0kV, V_{g2} = 750V, I_a = 1.0A$)	4.5	

Min **Max**

Inter-electrode capacitances, grounded filament:			
grid to anode	—	1.0	pF
input	108	122	pF
output	18	23	pF

Inter-electrode capacitances, grounded grid and screen:			
filament to anode	—	0.16	pF
input	48	58	pF
output	18	23	pF

Mechanical

Overall length	11.437 inches (290.5mm) max
Overall diameter	4.656 inches (118.3mm) max
Net weight	7.5 pounds (3.4kg) approx
Mounting position	vertical, either way up

COOLING

The valve has an integral water jacket and may be operated with the anode up or down. For operation with the anode up, the outer connector on the water jacket must be used as the water inlet; with the anode down, the central connector must be the inlet. Minimum water cooling requirements are shown in the following table; higher rates of flow should be used where possible. An allowance of 900 watts for the power dissipated by the filament and grids has been made in the values given.

Anode dissipation (kW)	Water flow (gal/min)	Pressure drop lb/in ²
6.0	4.0	2.2
8.0	5.1	3.1
10	6.3	4.3
12	7.4	5.5

The water outlet temperature must not exceed 70°C, and the water inlet pressure must not exceed 50 lb/in².

Forced-air cooling of the base is also required; the use of air distribution socket MA87 is recommended. A flow of approximately 30ft³/min through the socket and over the seals will be sufficient. At frequencies below 30MHz the base may be cooled by directing approximately 10ft³/min through a 0.750 inch diameter tube directly at the central stud of the base. The tube should not be more than 2 inches from the stud.

The cooling water and air flows may be removed simultaneously with the tube power.

AUDIO FREQUENCY POWER AMPLIFIER AND MODULATOR

(Class AB1 — See Note 2)

MAXIMUM RATINGS (Absolute values)

Anode voltage	7.5	kV max
Anode current	4.0	A max
Anode dissipation	12	kW max
Screen voltage	1.5	kV max
Screen dissipation	250	W max
Grid dissipation	75	W max

TYPICAL OPERATING CONDITIONS

(Class AB1, two valves)

Anode voltage	4.0	5.0	6.0	7.5 kV
Screen voltage	1.5	1.5	1.5	1.5 kV
Grid voltage	-315	-320	-330	-340 V
Peak a.f. voltage, grid to grid	305	310	320	330 V
Anode current (zero signal)	1.0	1.0	1.0	1.0 A
Anode current (max. signal)	6.66	6.66	6.66	6.66 A
Screen current (zero signal)	0	0	0	0 A
Screen current (max. signal)	0.33	0.32	0.30	0.25 A
Anode dissipation per tube (maximum signal)	6.67	7.95	8.10	9.05kW
Effective load (anode to anode)	0.94	1.32	1.70	2.28kΩ
Nominal driving power (maximum signal)	0	0	0	0 W
Output power (max. signal)	13.3	17.5	23.8	31.9 kW

RADIO FREQUENCY LINEAR AMPLIFIER

(Class AB1 — See Note 2)

MAXIMUM RATINGS (Absolute values)

Anode voltage	7.5	kV max
Anode current	4.0	A max
Anode dissipation	12	kW max
Screen voltage	1.5	kV max
Screen dissipation	250	W max
Grid dissipation	75	W max

TYPICAL OPERATING CONDITIONS

(Peak envelope or modulation crest conditions, below 30MHz)

Anode voltage	7.5	kV
Screen voltage	1.5	kV
Grid voltage (see note 3)	-340	V
Peak r.f. grid voltage	330	V
Anode current (zero signal)	0.50	A
Anode current (maximum signal)	3.33	A
Screen current (maximum signal)	0.125	A
Anode dissipation	9.05	kW
Nominal driving power	0	W
Output power (see note 4)	15.95	kW

ANODE MODULATED R.F. POWER AMPLIFIER

(Class C Telephony, carrier conditions per valve for use with a maximum modulation factor of 1.0)

MAXIMUM RATINGS (Absolute values)

Anode voltage	5.0	kV max
Anode current	2.5	A max
Anode dissipation (see note 5)	6.65	kW max
Screen voltage	1.0	kV max
Screen dissipation	250	W max
Grid dissipation	75	W max

TYPICAL OPERATING CONDITIONS (below 30MHz)

Anode voltage	5.0	kV
Screen voltage	500	V
Grid voltage	-350	V
Peak a.f. screen voltage (for 100% modulation)	500	V
Peak r.f. grid voltage	550	V
Anode current	2.4	A
Screen current	0.4	A
Grid current	0.22	A
Anode dissipation	3.5	kW
Nominal driving power	120	W
Output power	8.5	kW

R.F. POWER AMPLIFIER OR OSCILLATOR

(Class C Telegraphy, key down conditions, one valve)

MAXIMUM RATINGS (Absolute values)

	Up to 30MHz	30-60MHz	60-110MHz	
Anode voltage	7.5	7.0	6.5	kV max
Anode current	3.0	2.8	2.6	A max
Anode dissipation	10	10	10	kW max
Screen voltage	1.5	1.5	1.5	kV max
Screen dissipation	250	250	250	W max
Grid dissipation	75	75	75	W max

TYPICAL OPERATING CONDITIONS (below 30MHz)

Anode voltage	7.5	kV
Screen voltage	500	V
Grid voltage	-350	V
Peak r.f. grid voltage	590	V
Anode current	2.8	A
Screen current	0.5	A
Grid current	0.25	A
Anode dissipation	5.0	kW
Nominal driving power	150	W
Output power	16	kW



NOTES

1. The valve must be operated at the stated filament voltage. Fluctuation in filament voltage must not exceed $\pm 5\%$.
2. Grid current does not flow during any part of the audio frequency cycle.
3. The grid voltage is adjusted to obtain the specified zero-signal anode current.
4. The peak envelope or r.f. output power at the crest of the modulation envelope.
5. This corresponds to 10kW anode dissipation at 100% sine wave modulation.

TYPICAL CONSTANT CURRENT CHARACTERISTICS

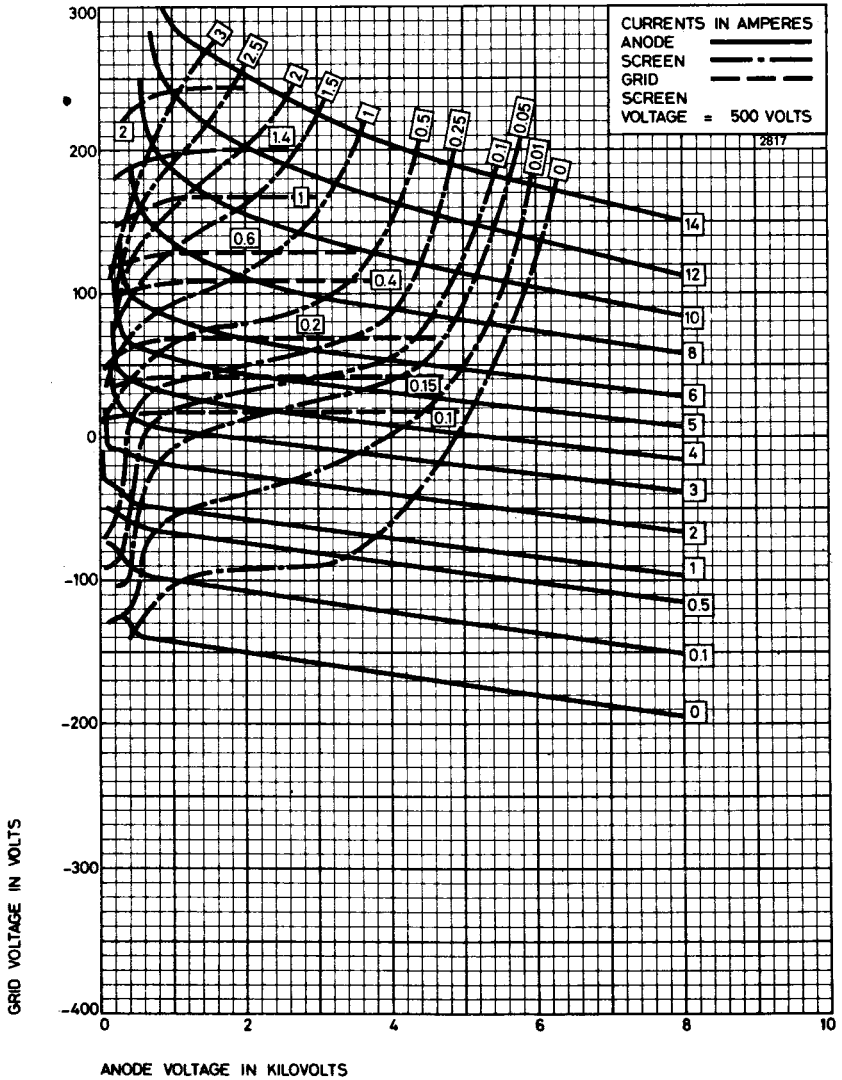

OUTLINE

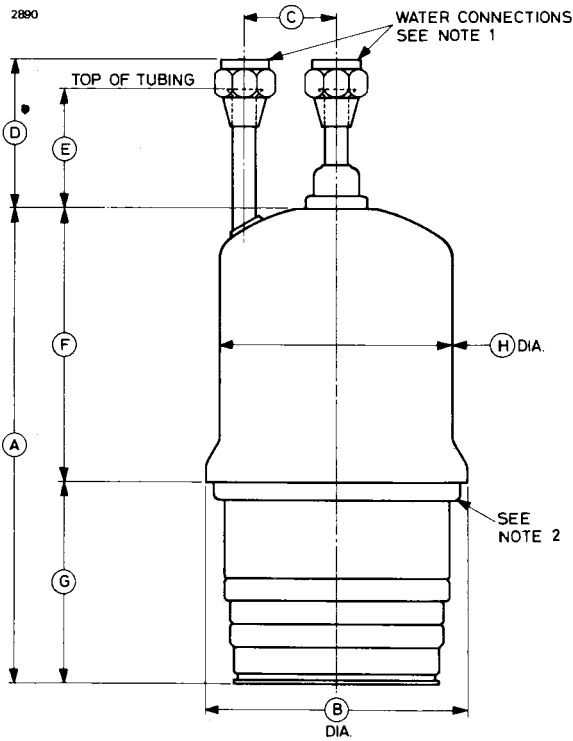

Ref	Inches	Millimetres
A	8.375 ± 0.250	212.7 ± 6.4
B	4.656 max	118.3 max
	4.524 min	114.9 min
C	1.625 ± 0.125	41.28 ± 3.18
D	2.562 ± 0.250	65.07 ± 6.35
E	2.062 ± 0.125	52.37 ± 3.18
F	4.903 ± 0.122	124.5 ± 3.1
G	3.500 ± 0.150	88.90 ± 3.81
H	4.156 max	105.6 max
	4.000 min	101.6 min

Millimetre dimensions have been derived from inches.

OUTLINE DETAILS

2822

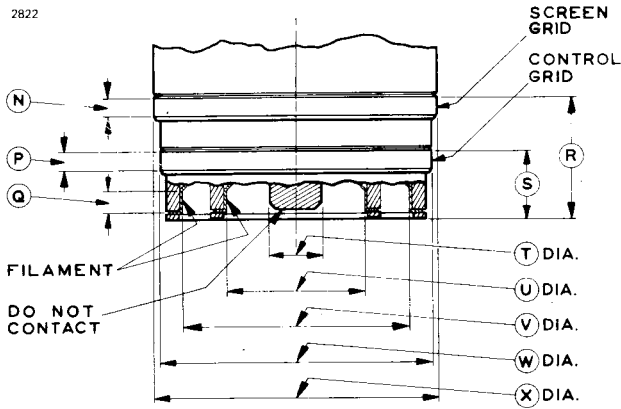

Ref	Inches	Millimetres
N	0.188 min	4.78 min
P	0.188 min	4.78 min
Q	0.188 min	4.78 min
R	1.795 ± 0.031	45.59 ± 0.79
S	1.018 ± 0.032	25.86 ± 0.81
T	0.740 ± 0.020	18.80 ± 0.51
U	1.916 ± 0.020	48.67 ± 0.51
V	3.153 ± 0.020	80.09 ± 0.51
W	3.812 ± 0.020	96.82 ± 0.51
X	4.000 ± 0.020	101.6 ± 0.5

Millimetre dimensions have been derived from inches.

OUTLINE NOTES

1. Water connection 1/2-inch external diameter copper tubing with 1/2-inch S.A.E. flare fitting nuts. With the anode uppermost as shown, the outer connector is the water inlet. With the anode down, the central connector is the inlet.
2. This surface must not be used as an electrical contact and it must not be clamped in any way.

OUTLINE OF AIR DISTRIBUTION SOCKET MA87

2826

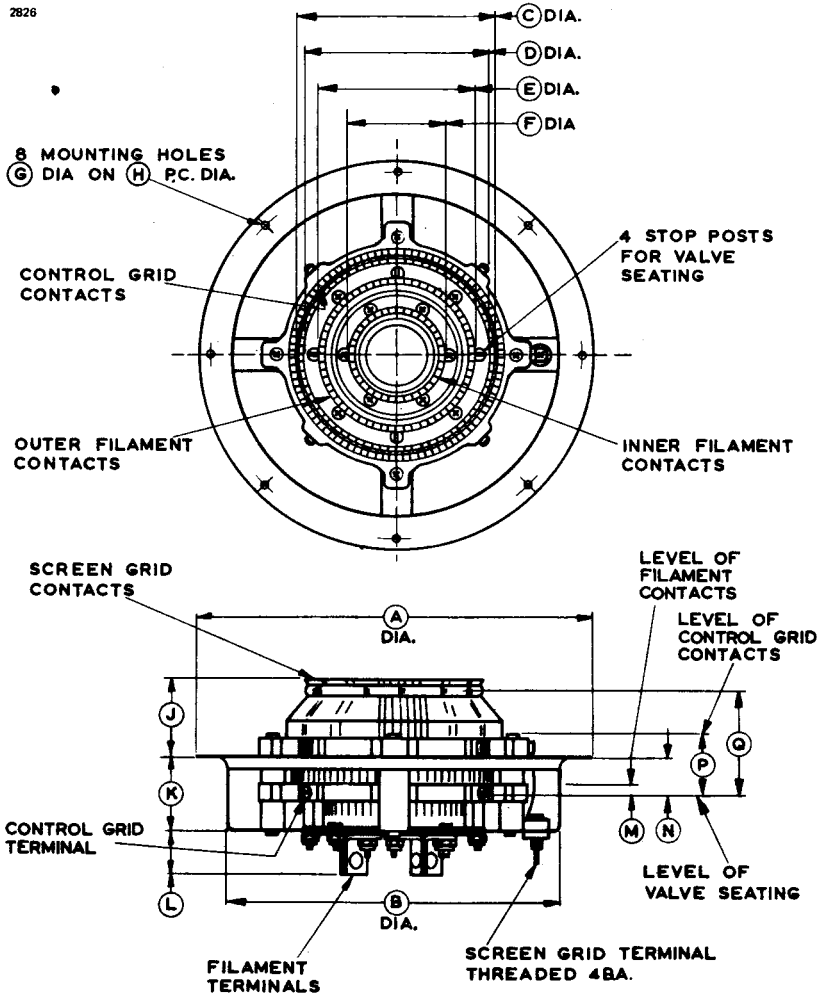

OUTLINE DETAIL OF MA87 (View from underside showing terminals)

2827

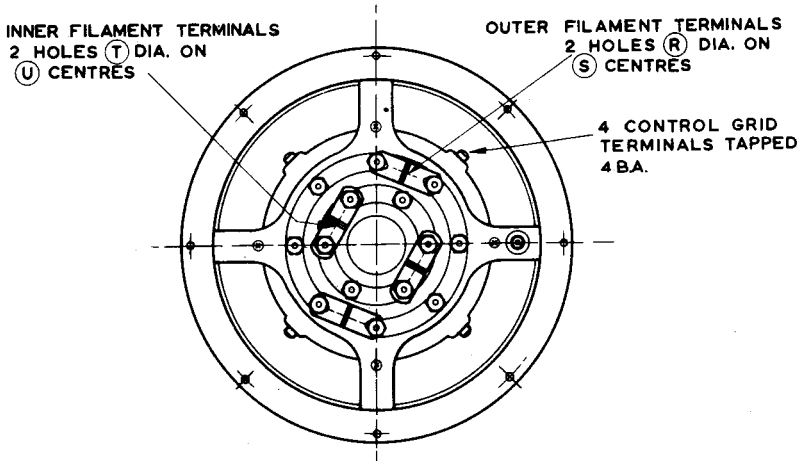

Ref	Inches	Millimetres	Ref	Inches	Millimetres
A	8.266 max	210.0 max	L	0.894 ± 0.031	22.71 ± 0.79
B	6.766 max	171.9 max	M	0.228 ± 0.012	5.79 ± 0.30
C	3.910 ± 0.030	99.31 ± 0.76	N	0.672 ± 0.017	17.07 ± 0.43
D	3.702 ± 0.030	94.03 ± 0.76	P	0.841 ± 0.015	21.36 ± 0.38
E	3.281 ± 0.030	83.34 ± 0.76	Q	1.626 ± 0.031	41.30 ± 0.79
F	2.031 ± 0.030	51.59 ± 0.76	R	0.250 ± 0.015	6.35 ± 0.38
G	0.147	3.73	S	1.562 ± 0.015	39.67 ± 0.38
H	7.750	196.9	T	0.250 ± 0.015	6.35 ± 0.38
J	1.125 ± 0.015	28.58 ± 0.38	U	0.937 ± 0.015	23.80 ± 0.38
K	1.489 ± 0.028	37.82 ± 0.71			

Millimetre dimensions have been derived from inches.



4CX1000A 4CX1000K

R.F. POWER
TETRODES

The data should be read in conjunction with the Power Tetrode Preamble.

ABRIDGED DATA

Forced-air cooled tetrodes, coaxial metal-ceramic envelope, for audio or linear single sideband amplifiers. 4CX1000K is similar to the 4CX1000A but has a solid disc screen contact to permit use up to 400MHz.

Anode dissipation	1.0	kW max
Anode voltage	3.0	kV max
Frequency for full ratings	110	MHz max
Output power (two valves, class AB ₁ audio)	3.26	kW

GENERAL

Electrical

Cathode	indirectly heated, oxide coated	
Heater voltage (see note 1):		
for operation at 30MHz	6.0	V
for operation at 110MHz	5.75	V
for operation at 400MHz	5.5	V
Heater current at 6.0V	9.0	A
Cathode heating time (minimum)	3.0	min
Mutual conductance ($I_a = 1.0A$)	37	mA/V
Inter-electrode capacitances (in shielded fixture)		

	Min	Max	
Grounded cathode:			
grid to anode	—	0.022	pF
input	77	90	pF
output	11	13	pF
Grounded grid and screen:			
cathode to anode	—	0.004	pF
input	32.5	38	pF
output	11	13	pF

Mechanical

Overall length	4.800 inches (121.9mm) max
Overall diameter	3.365 inches (85.47mm) max
Net weight	1 3/4 pounds (0.8kg) approx
Mounting position	any

COOLING

Sufficient air must be passed through the radiator and over the ceramic to metal seals to maintain the temperatures below the maximum rated values of:

Anode core	250	°C max
Ceramic to metal seals	250	°C max

For operation at sea level in an ambient temperature of 40°C and with an anode dissipation of 1.0kW, an air flow of 25ft³/min (0.71m³/min), corresponding to a pressure drop across the valve of 0.2 inch (0.51cm) of water, is adequate. At an altitude of 10 000 feet (3.05km) a flow of 37ft³/min (1.05 m³/min), corresponding to a pressure drop across the valve of 0.3 inch (0.76cm) of water, is necessary.

The air flow should be maintained during standby periods when only the heater voltage is applied to the tube.

AUDIO FREQUENCY POWER AMPLIFIER OR MODULATOR

(Class AB₁ – See Note 2)

MAXIMUM RATINGS (Absolute values)

Anode voltage	3.0	kV max
Anode current	1.0	A max
Anode dissipation	1.0	kW max
Screen voltage	400	V max
Screen dissipation	12	W max
Grid dissipation (see note 3)	0	W max

TYPICAL OPERATING CONDITIONS (Class AB₁, two valves)

Anode voltage (see note 4)	2.0	2.5	3.0	kV
Screen voltage (see note 5)	325	325	325	V
Grid voltage (see note 6)	-60	-60	-60	V
Anode current (zero signal)	500	500	500	mA
Anode current (maximum signal)	1.78	1.77	1.75	A
Screen current (zero signal) (approx)	16	12	10	mA
Screen current (maximum signal) (approx)	70	70	70	mA
Effective load (anode to anode)	2.04	2.85	3.68	kΩ
Nominal driving power (maximum signal)	0	0	0	W
Output power (maximum signal)	1.86	2.60	3.26	kW

RADIO FREQUENCY LINEAR AMPLIFIER
(Class AB₁ — See Note 2) (Single Side-band Suppressed Carrier Operation)

MAXIMUM RATINGS (Absolute values)

Anode voltage	3.0	kV max
Anode current	1.0	A max
Anode dissipation	1.0	kW max
Screen voltage	400	V max
Screen dissipation	12	W max
Grid dissipation (see note 3)	0	W max

TYPICAL OPERATING CONDITIONS (at frequencies below 30MHz)

Anode voltage (see note 4)	2.0	2.5	3.0	kV
Screen voltage (see note 5)	325	325	325	V
Grid voltage (see note 6)	-60	-60	-60	V
Anode current:				
zero signal	250	250	250	mA
single tone	890	885	875	mA
two tone (average)	645	650	635	mA
Screen current (approx):				
zero signal	8.0	6.0	5.0	mA
single tone	35	35	35	mA
two tone (average)	10	8.0	8.0	mA
Output power	0.93	1.30	1.63	kW

NOTES

1. The valve must be operated at the stated heater voltage. Fluctuation in heater voltage must not exceed $\pm 5\%$.
2. Grid current does not flow during any part of the cycle.
3. The grid dissipation rating is zero and positive grid operation must be avoided. Peak grid currents of less than 5.0mA may be permitted to flow for peak signal monitoring purposes. Under certain conditions the negative grid current may rise to as much as 1.0mA and for this reason the grid circuit impedance must not exceed 2.0k Ω in the absence of a cathode resistor.
4. The anode voltage must not be less than twice the screen voltage at the bottom of the anode voltage swing.
5. Positive or negative screen currents of the order of 30mA may flow under certain operating conditions. The screen voltage must be maintained constant for any positive or negative values of screen current that may flow.
6. Adjusted to give the specified zero signal anode current.

TYPICAL ANODE AND SCREEN CHARACTERISTICS

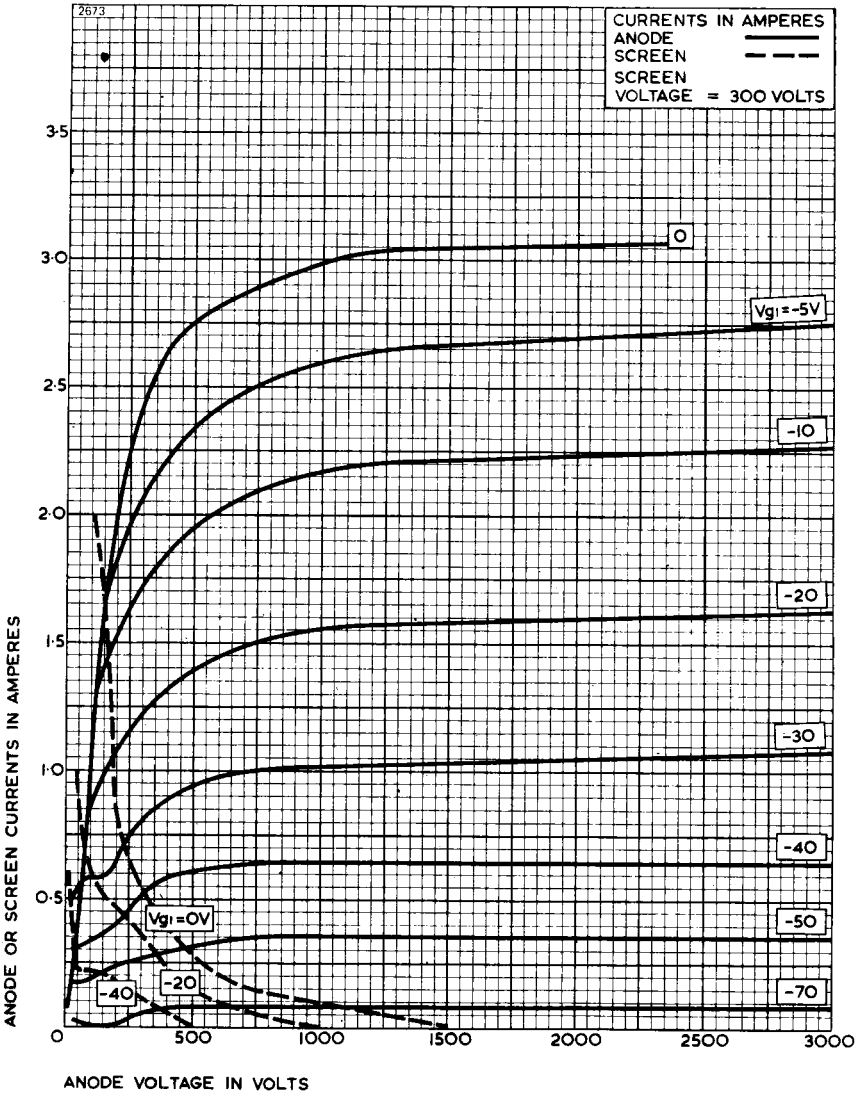

TYPICAL CONSTANT CURRENT CHARACTERISTICS

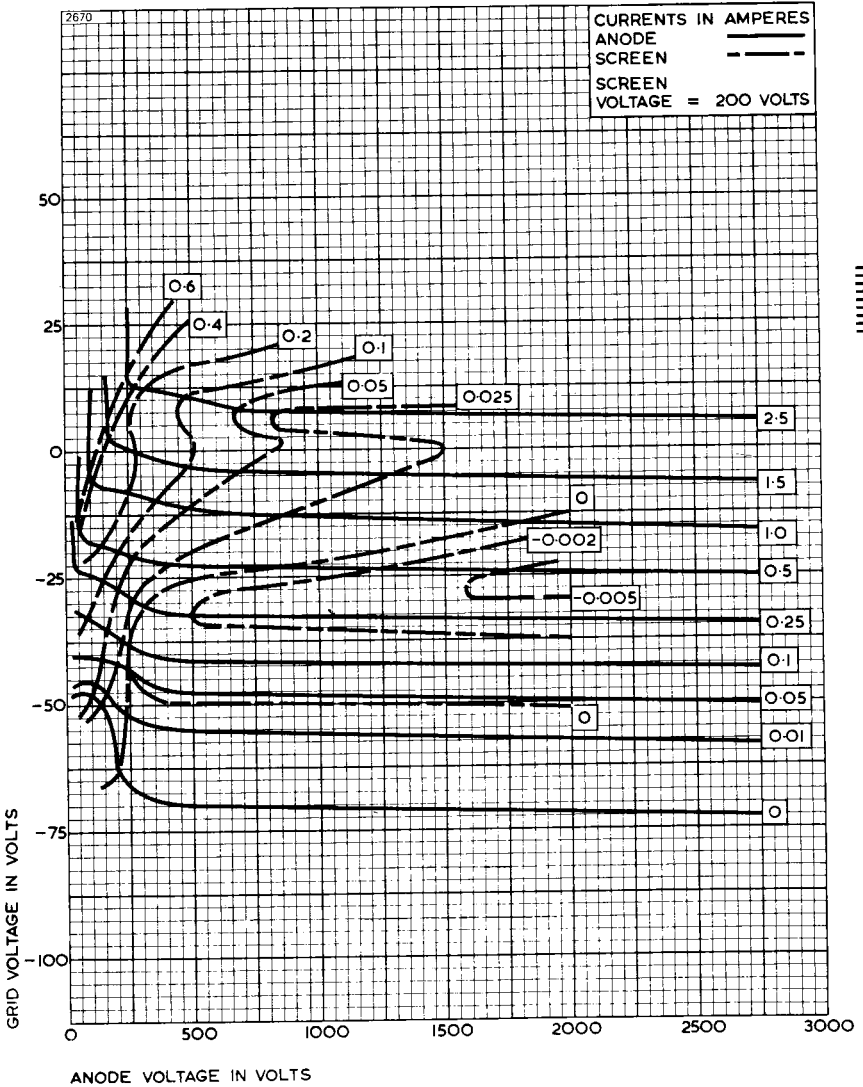

TYPICAL CONSTANT CURRENT CHARACTERISTICS

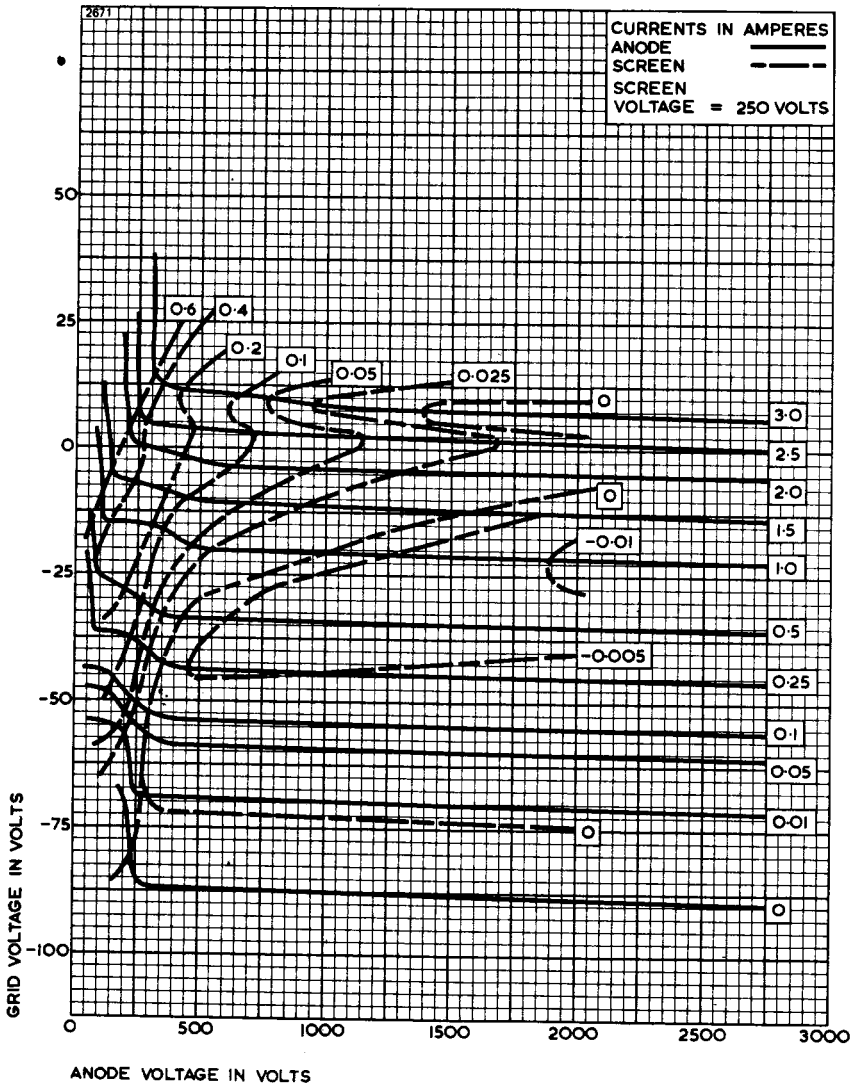

TYPICAL CONSTANT CURRENT CHARACTERISTICS

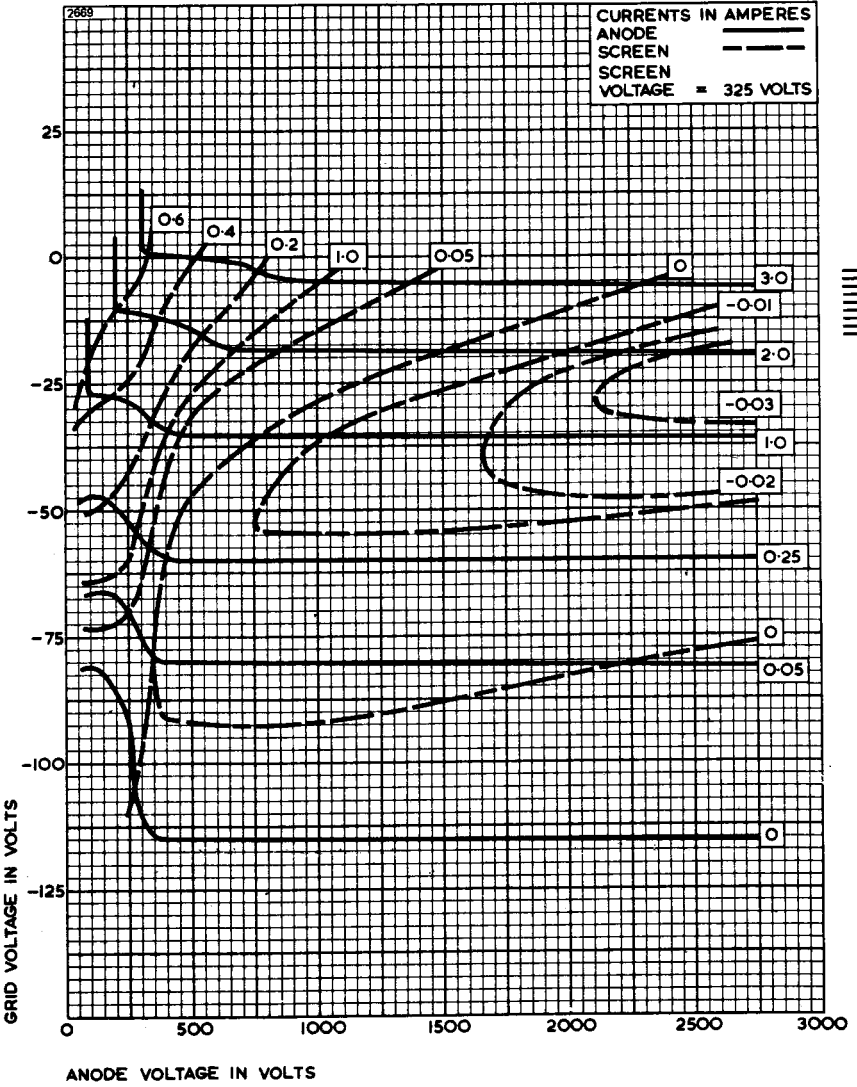

TYPICAL CONSTANT CURRENT CHARACTERISTICS

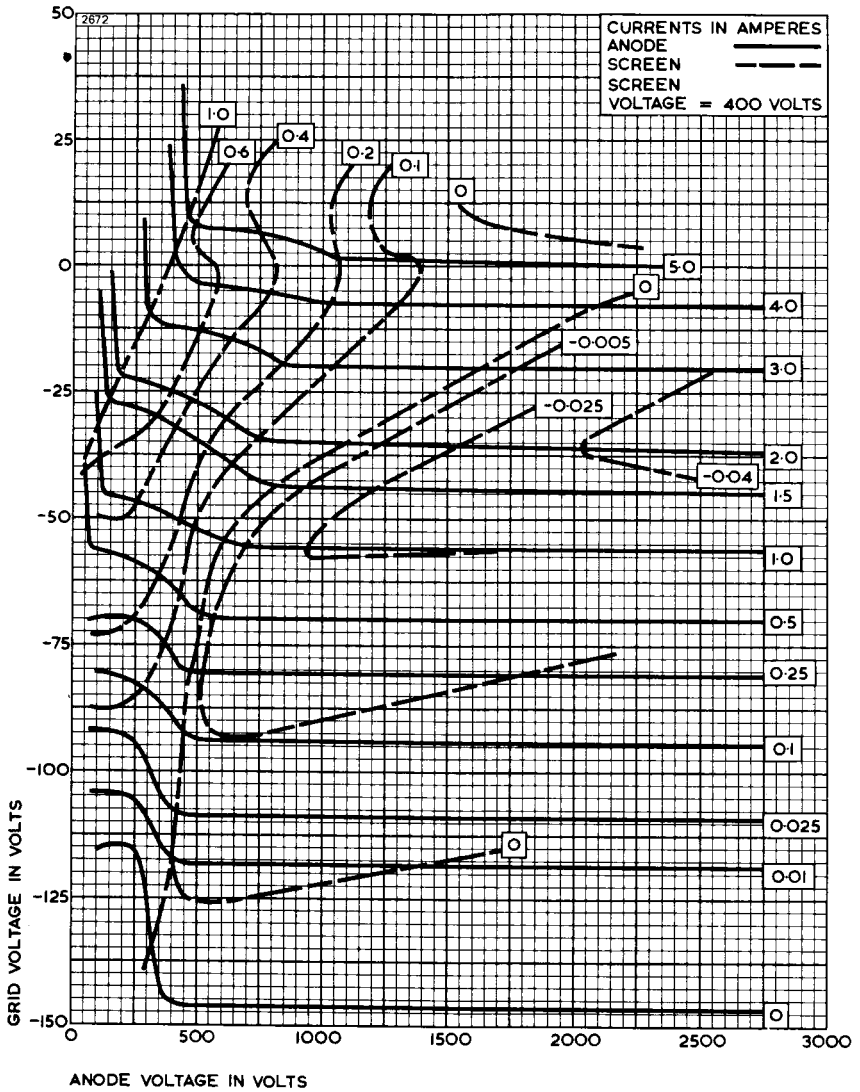

OUTLINE FOR 4CX1000A

2165A

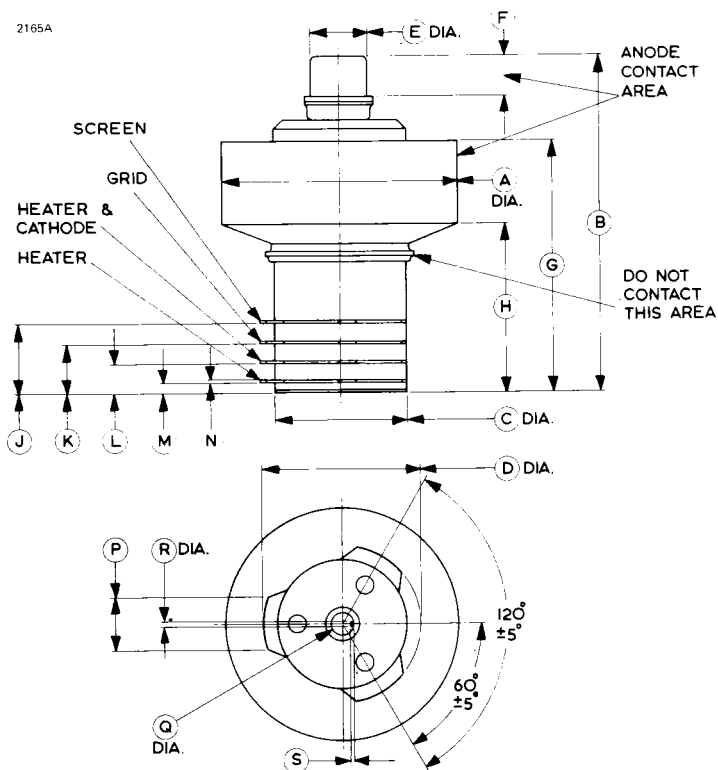

Ref	Inches	Millimetres	Ref	Inches	Millimetres
A	3.365 max	85.47 max	K	0.700 ± 0.025	17.78 ± 0.64
B	4.800 max	121.9 max	L	0.425 ± 0.025	10.80 ± 0.64
C	1.885 ± 0.015	47.88 ± 0.38	M	0.155 ± 0.015	3.94 ± 0.38
D	2.275 ± 0.025	57.78 ± 0.64	N	0.025 ± 0.005	0.64 ± 0.13
E	0.812 ± 0.005	20.62 ± 0.13	P	0.750	19.05
F	0.578	14.68	Q	0.320 ± 0.006	8.13 ± 0.15
G	3.550 max	90.17 max	R	0.065 ± 0.008	1.65 ± 0.20
H	2.380 max	60.45 max	S	0.033 ± 0.010	0.84 ± 0.25
J	0.975 ± 0.025	24.77 ± 0.64			

Millimetre dimensions have been derived from inches.

OUTLINE FOR 4CX1000K

2674A

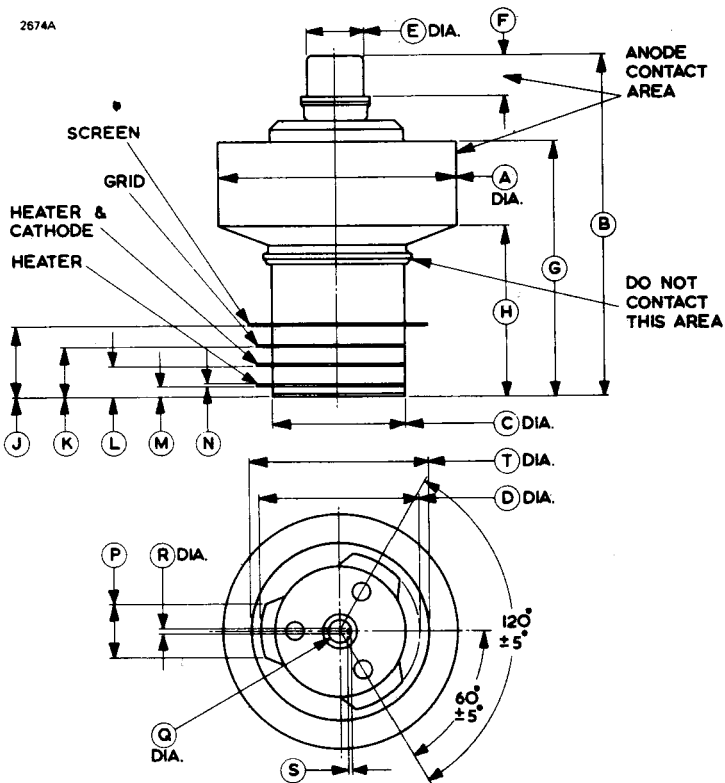

Ref	Inches	Millimetres	Ref	Inches	Millimetres
A	3.365 max	85.47 max	K	0.700 ± 0.025	17.78 ± 0.64
B	4.800 max	121.9 max	L	0.425 ± 0.025	10.80 ± 0.64
C	1.885 ± 0.015	47.88 ± 0.38	M	0.155 ± 0.015	3.94 ± 0.38
D	2.275 ± 0.025	57.78 ± 0.64	N	0.025 ± 0.005	0.64 ± 0.13
E	0.812 ± 0.005	20.62 ± 0.13	P	0.750	19.05
F	0.578	14.68	Q	0.320 ± 0.006	8.13 ± 0.15
G	3.550 max	90.17 max	R	0.065 ± 0.008	1.65 ± 0.20
H	2.380 max	60.45 max	S	0.033 ± 0.010	0.84 ± 0.25
J	0.975 ± 0.025	24.77 ± 0.64	T	2.531 max	64.29 max

Millimetre dimensions have been derived from inches.

English Electric Valve Company Limited

Chelmsford, Essex, England

4CX1000A/K

Page 10

Printed in England



4CX1500B

(8660)

R.F. POWER TETRODE

The data should be read in conjunction with the Power Tetrode Preamble.

ABRIDGED DATA

Forced-air cooled tetrode, coaxial metal-ceramic envelope, for audio or r.f. linear single sideband amplifiers. It features exceptionally low intermodulation distortion and low grid interception.

Anode dissipation	1.5	kW max
Anode voltage	3.0	kV max
Output power (two valves, class AB1 audio)	2.77	kW

GENERAL

Electrical

Cathode	indirectly heated, oxide coated	
Heater voltage (see note 1)	6.0	V
Heater current	9.0	A
Cathode heating time (minimum)	3.0	minutes
Mutual conductance ($I_a = 0.5A, V_{g2} = 225V$)	30	mA/V
Inter-electrode capacitances (in shielded fixture)		

Min	Max	
------------	------------	--

Grounded cathode:		
grid to anode	—	0.022 pF
input	77	90 pF
output	11	13 pF
Grounded grid and screen:		
cathode to anode	—	0.005 pF
input	35	41 pF
output	11	13 pF

Mechanical

Overall length	4.800 inches (121.9mm) max
Overall diameter	3.365 inches (85.47mm) max
Net weight	1¾ pounds (0.8kg) approx
Mounting position	any

COOLING

Sufficient air must be passed through the radiator and over the ceramic to metal seals to maintain the temperatures below the maximum rated values of:

Anode core	250	°C max
Ceramic to metal seals	250	°C max

Air flow requirements to maintain the seal temperatures at 225°C with an ambient temperature of 50°C and operating frequency less than 30MHz are given below. The figures specified take into account the grid and heater dissipations.

Anode [•] dissipation (kW)	Sea level		6000 feet	
	Air flow (ft ³ /min)	Pressure drop (in. water gauge)	Air flow (ft ³ /min)	Pressure drop (in. water gauge)
1.0	22	0.2	26	0.25
1.5	39	0.5	49	0.63

At other altitudes and ambient temperatures, the air flow must be adjusted to give equivalent cooling.

The air flow should be maintained during standby periods when only the heater voltage is applied to the tube.

AUDIO FREQUENCY POWER AMPLIFIER OR MODULATOR

(Class AB1 – See Note 2)

MAXIMUM RATINGS (Absolute values)

Anode voltage	3.0	kV max
Anode current	0.9	A max
Anode dissipation	1.5	kW max
Screen voltage	400	V max
Screen dissipation	12	W max
Grid dissipation	1.0	W max

TYPICAL OPERATING CONDITIONS

(Class AB1, two valves)

Anode voltage (see note 3)	2.0	2.5	2.9	kV
Screen voltage (see note 4)	325	325	325	V
Grid voltage (see note 5)	-60	-60	-60	V
Anode current (zero signal)	500	500	500	mA
Anode current (maximum signal)	1.68	1.69	1.69	A
Screen current (zero signal) (approx)	-30	-25	-20	mA
Screen current (maximum signal) (approx)	-27	-33	-32	mA
Effective load (anode to anode)	1.95	2.72	3.33	kΩ
Nominal driving power (maximum signal)	0	0	0	W
Output power (maximum signal)	1.60	2.26	2.77	kW

**RADIO FREQUENCY LINEAR AMPLIFIER
(Class AB)**

MAXIMUM RATINGS (Absolute values)

Anode voltage	3.0	kV max
Anode current	0.9	A max
Anode dissipation	1.5	kW max
Screen voltage	400	V max
Screen dissipation	12	W max
Grid dissipation	1.0	W max

TYPICAL OPERATING CONDITIONS

(at frequencies below 30MHz)

Anode voltage (see note 3)	2.5	2.75	2.9	kV
Screen voltage (see note 4)	225	225	225	V
Grid voltage (see note 5)	-34	-34	-34	V
Peak r.f. grid voltage	46	45	41	V
Anode current:				
zero signal	300	300	300	mA
single tone	720	755	710	mA
two tone	530	555	542	mA
Screen current (approx):				
single tone	-7.0	-14	-15	mA
two tone	-11	-11	-11	mA
Grid current:				
single tone	1.3	0.95	0.53	mA
two tone	0.06	0.20	0.06	mA
Driving power (see note 6)	1.5	1.5	1.5	W
Output power	0.9	1.1	1.1	kW

NOTES

1. The valve must be operated at the stated heater voltage. Fluctuation in heater voltage must not exceed $\pm 5\%$.
2. Grid current does not flow during any part of the cycle.
3. The anode voltage must not be less than twice the screen voltage at the bottom of the anode voltage swing.
4. Positive or negative screen currents of the order of 35mA may flow under certain operating conditions. The screen voltage must be maintained constant for any positive or negative values of screen current that may flow.
5. Adjusted to give the specified zero signal anode current.
6. The driving power specified includes the dissipation in a 1000Ω resistor connected between the control grid and cathode.

TYPICAL CONSTANT CURRENT CHARACTERISTICS

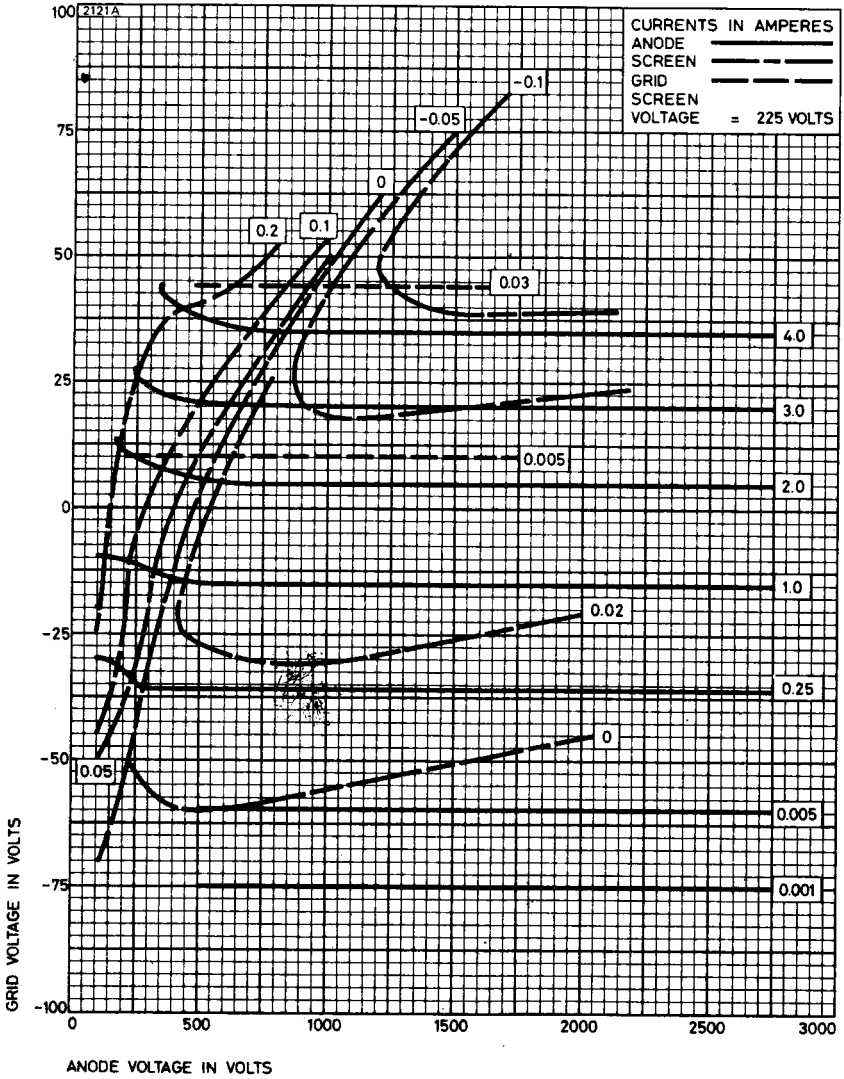

TYPICAL CONSTANT CURRENT CHARACTERISTICS

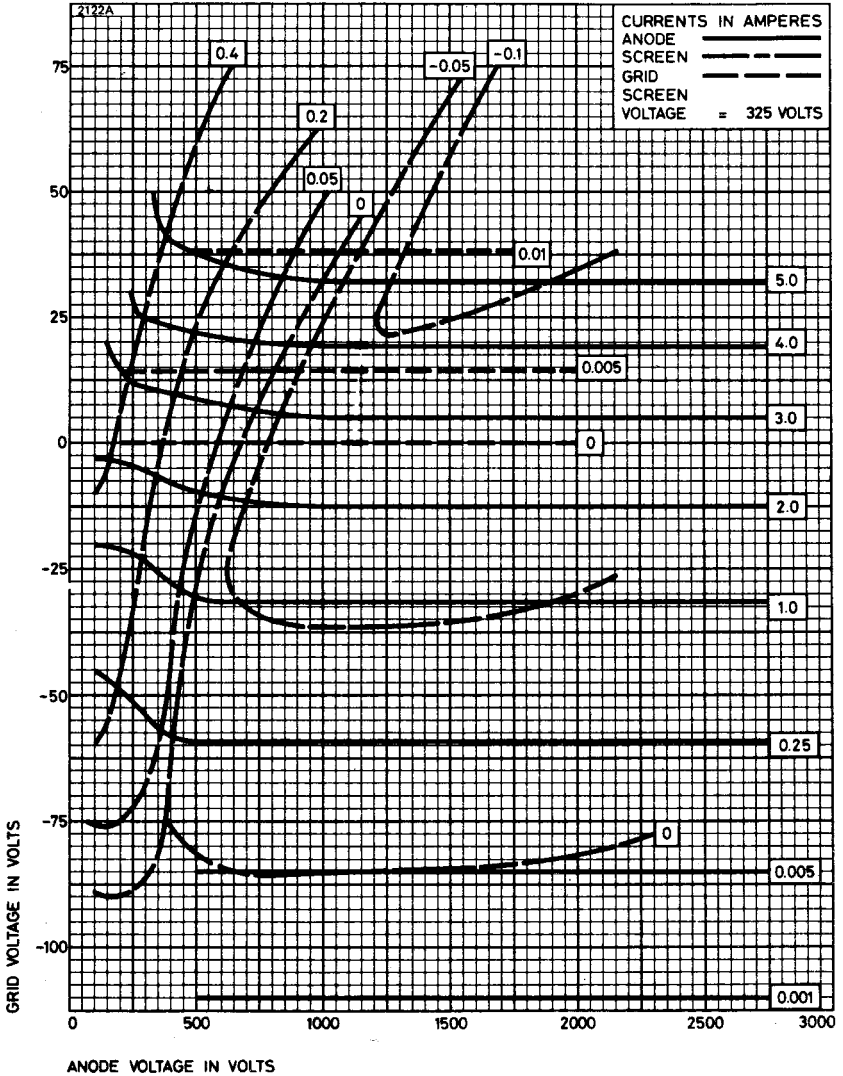

OUTLINE (All dimensions without limits are nominal)

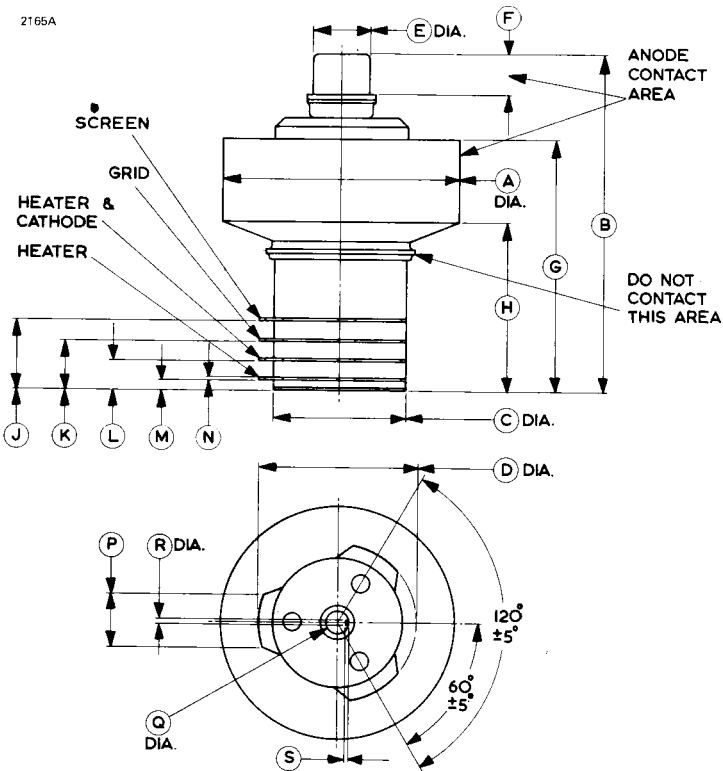

Ref	Inches	Millimetres	Ref	Inches	Millimetres
A	3.365 max	85.47 max	K	0.700 ± 0.025	17.78 ± 0.64
B	4.800 max	121.9 max	L	0.425 ± 0.025	10.80 ± 0.64
C	1.885 ± 0.015	47.88 ± 0.38	M	0.155 ± 0.015	3.94 ± 0.38
D	2.275 ± 0.025	57.78 ± 0.64	N	0.025 ± 0.005	0.64 ± 0.13
E	0.812 ± 0.005	20.62 ± 0.13	P	0.750	19.05
F	0.578	14.68	Q	0.320 ± 0.006	8.13 ± 0.15
G	3.550 max	90.17 max	R	0.065 ± 0.008	1.65 ± 0.20
H	2.380 max	60.45 max	S	0.033 ± 0.010	0.84 ± 0.25
J	0.975 ± 0.025	24.77 ± 0.64			

Millimetre dimensions have been derived from inches.



4CX5000A

R.F. POWER TETRODE

Service Type CV8295

The data should be read in conjunction with the Power Tetrode Preamble.

ABRIDGED DATA

Forced-air cooled tetrode, coaxial metal-ceramic envelope, for audio, linear single sideband or screen-modulated r.f. amplifiers.

Anode dissipation (class C telegraphy)	5.0	kW max
Anode voltage	7.5	kV max
Frequency for full ratings	30	MHz max
Frequency at reduced ratings	110	MHz max
Output power (class C telegraphy)	16	kW

GENERAL

Electrical

Filament	thoriated tungsten		
Filament voltage (see note 1)	7.5	V	
Filament current	75	A	
Grid-screen amplification factor ($V_a = 2.0kV, V_{g2} = 750V, I_a = 1.0A$)	4.5		
Inter-electrode capacitances:	Grounded Filament	Grounded Grid and Screen	
	Min	Max	
input	108	122	pF
output	18	23	pF
feedback	—	1.0	pF

Mechanical

Overall length	9.125 inches (232mm) max
Overall diameter	4.940 inches (125.5mm) max
Net weight	9.5 pounds (4.3kg) approx
Mounting position	vertical, either way up

COOLING

Sufficient air must be passed over the concentric base terminals and through the radiator fins to maintain the temperatures of the ceramic to metal seals and the radiator core below the maximum rated value of 250°C. It is recommended that an air distribution socket MA87 and chimney type MA104 be used with the tube (see pages 10, 11 and 12).

The air flows required with the recommended air socket and chimney to maintain the seal temperatures at 200°C in an ambient temperature of 50°C at sea level and with an operating frequency of less than 30MHz are given

below. At higher ambient temperatures, altitudes or frequencies the rate of flow must be adjusted to give equivalent cooling and should be determined individually in each case. An allowance of 1000 watts for the power dissipated by the filament and grids has been made in the values given.

Anode dissipation (kW)	Air flow		Water pressure drop	
	ft ³ /min	m ³ /min	inches	mm
2.0	75	2.1	0.4	10.2
3.0	105	3.0	0.7	17.8
4.0	145	4.1	1.1	28
5.0	190	5.4	1.5	38
6.0	230	6.5	2.0	51

AUDIO FREQUENCY POWER AMPLIFIER OR MODULATOR (Class AB1) (See Note 2)

MAXIMUM RATINGS (Absolute values)

Anode voltage	7.5	kV max
Anode current	4.0	A max
Anode dissipation	6.0	kW max
Screen voltage	1.5	kV max
Screen dissipation	250	W max
Grid dissipation	75	W max

TYPICAL OPERATING CONDITIONS (Class AB1, two valves)

Anode voltage	4.0	5.0	6.0	7.0	kV
Screen voltage	1.25	1.25	1.25	1.25	kV
Grid voltage	-270	-280	-310	-325	V
Peak a.f. voltage, grid to grid	250	240	270	235	V
Anode current (zero signal)	1.25	1.00	0.83	0.70	A
Anode current (max. signal)	5.10	4.40	4.25	3.65	A
Screen current (zero signal)	0	0	0	0	A
Screen current (max. signal)	0.35	0.33	0.30	0.24	A
Anode dissipation (maximum signal)	4.2	4.2	4.2	4.2	kW
Effective load (anode to anode)	1.5	2.37	2.94	4.10	kΩ
Nominal driving power (maximum signal)	0	0	0	0	W
Output power (max. signal)	11.5	13.5	17	17.5	kW

RADIO FREQUENCY LINEAR AMPLIFIER

(Class AB1) (See Note 2)

MAXIMUM RATINGS (Absolute values)

Anode voltage	7.5	kV max
Anode current	4.0	A max
Anode dissipation	6.0	kW max
Screen voltage	1.5	kV max
Screen dissipation	250	W max
Grid dissipation	75	W max

TYPICAL OPERATING CONDITIONS

(Peak envelope or modulation crest conditions, below 30MHz)

Anode voltage	7.5	kV
Screen voltage	1.25	kV
Grid voltage (see note 3)	-300	V
Peak r.f. grid voltage	300	V
Anode current (zero signal)	0.5	A
Anode current (maximum signal)	1.9	A
Screen current (maximum signal)	0.2	A
Anode dissipation	4.2	kW
Nominal driving power	0	W
Output power (see note 4)	10	kW

SCREEN MODULATED R.F. POWER AMPLIFIER

(Class C Telephony, carrier conditions per valve for use with a maximum modulation factor of 1.0)

MAXIMUM RATINGS (Absolute values)

Anode voltage	7.5	kV max
Anode current	3.0	A max
Anode dissipation	5.0	kW max
Screen voltage	750	V max
Grid dissipation	75	W max

TYPICAL OPERATING CONDITIONS (below 30MHz)

Anode voltage	7.5	7.5	kV
Screen voltage	350	350	V
Grid voltage	-300	-300	V
Peak a.f. screen voltage for 100% modulation	550	550	V
Peak r.f. grid voltage	350	375	V
Anode current	0.9	1.14	A
Screen current (see note 5)	-10	-10	mA
Grid current	15	30	mA
Anode dissipation	4.0	5.0	kW
Effective load	2.0	1.6	k Ω
Nominal driving power	7.0	11	W
Output power	2.75	3.55	kW

ANODE MODULATED R.F. POWER AMPLIFIER

(Class C Telephony, carrier conditions per valve for use with a maximum modulation factor of 1.0)

MAXIMUM RATINGS (Absolute values)

Anode voltage	5.0	kV max
Anode current	2.5	A max
Anode dissipation (see note 6)	3.5	kW max
Screen voltage	1.0	kV max
Screen dissipation	250	W max
Grid dissipation	75	W max

TYPICAL OPERATING CONDITIONS (below 30MHz)

Anode voltage	5.0	kV
Screen voltage	500	V
Grid voltage	-400	V
Peak a.f. voltage (for 100% modulation)	450	V
Peak r.f. grid voltage	520	V
Anode current	1.4	A
Screen current	0.26	A
Grid current	0.05	A
Anode dissipation	1.1	kW
Nominal driving power	25	W
Output power	5.8	kW

R.F. POWER AMPLIFIER OR OSCILLATOR

(Class C Telegraphy, key down conditions, one valve)

MAXIMUM RATINGS (Absolute values)

	Up to 30MHz	30–60MHz	60–110MHz	
Anode voltage	7.5	7.0	6.5	kV max
Anode current	3.0	2.8	2.6	A max
Anode dissipation	5.0	5.0	5.0	kW max
Screen voltage	1.5	1.5	1.5	kV max
Screen dissipation	250	250	250	W max
Grid dissipation	75	75	75	W max

TYPICAL OPERATING CONDITIONS

	Up to 30MHz	88–108MHz	
Anode voltage	7.5	6.5	kV
Screen voltage	500	750	V
Grid voltage	–350	–350	V
Peak r.f. grid voltage	590	–	V
Anode current	2.8	2.3	A
Screen current	0.5	0.2	A
Grid current	0.25	0.05	A
Anode dissipation	5.0	–	kW
Nominal driving power	150	25	W
Output power	16	10	kW

NOTES

1. The valve must be operated at the stated filament voltage. Fluctuation in filament voltage must not exceed $\pm 5\%$.
2. Grid current does not flow during any part of the audio frequency cycle.
3. The grid voltage is adjusted to obtain the specified zero-signal anode current.
4. The peak envelope or r.f. output power at the crest of the modulation envelope.
5. The screen current is a function of the loading; values from -20mA to $+20\text{mA}$ may be considered typical at carrier level.
6. This corresponds to 5.0kW anode dissipation at 100% sine wave modulation.

TYPICAL CONSTANT CURRENT CHARACTERISTICS

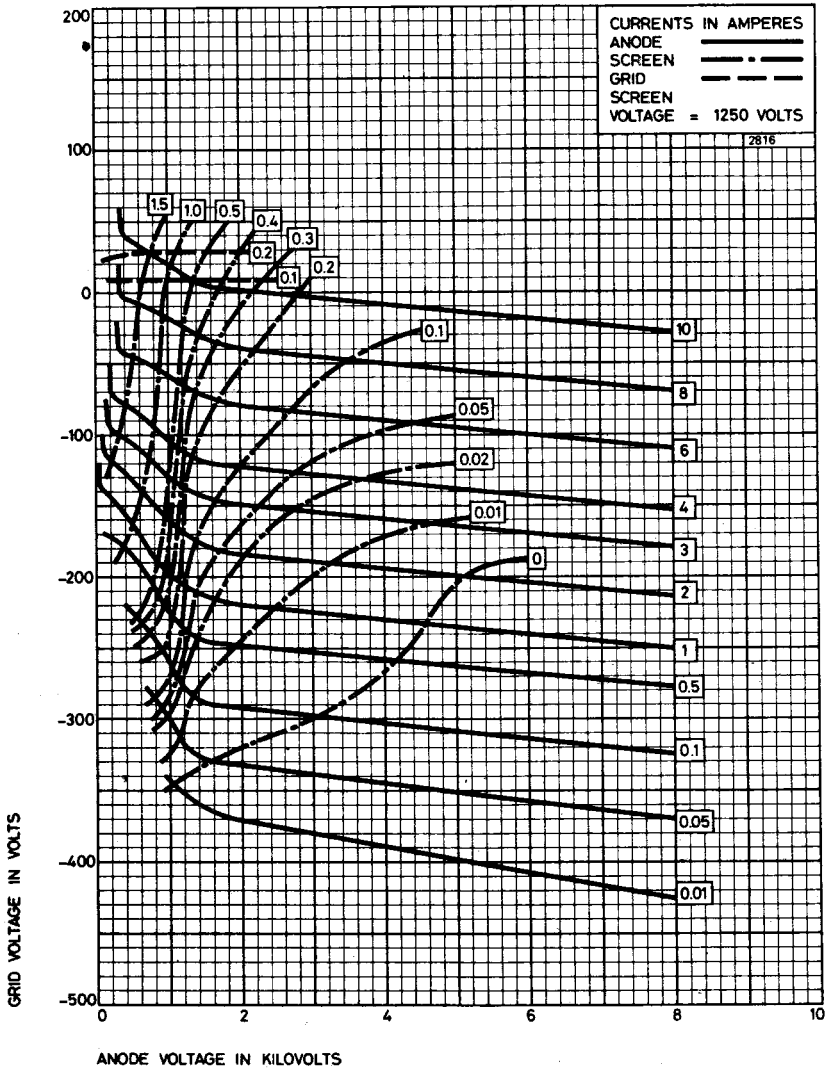

TYPICAL CONSTANT CURRENT CHARACTERISTICS

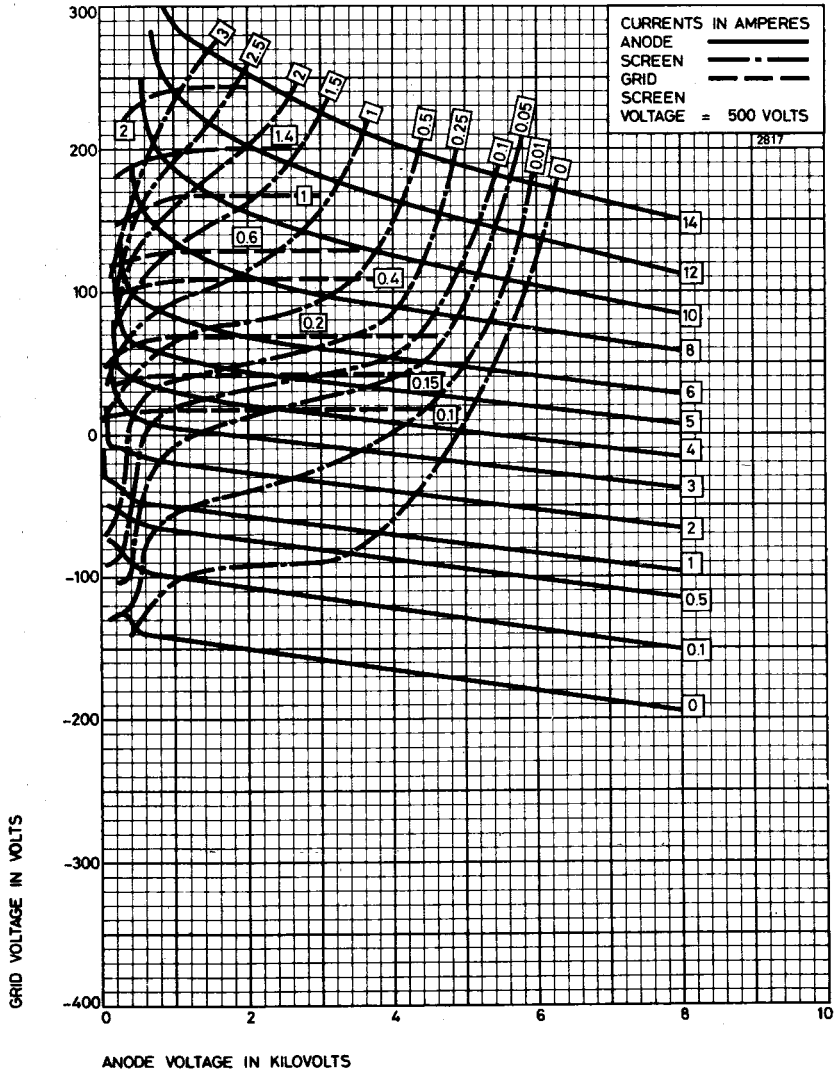

OUTLINE

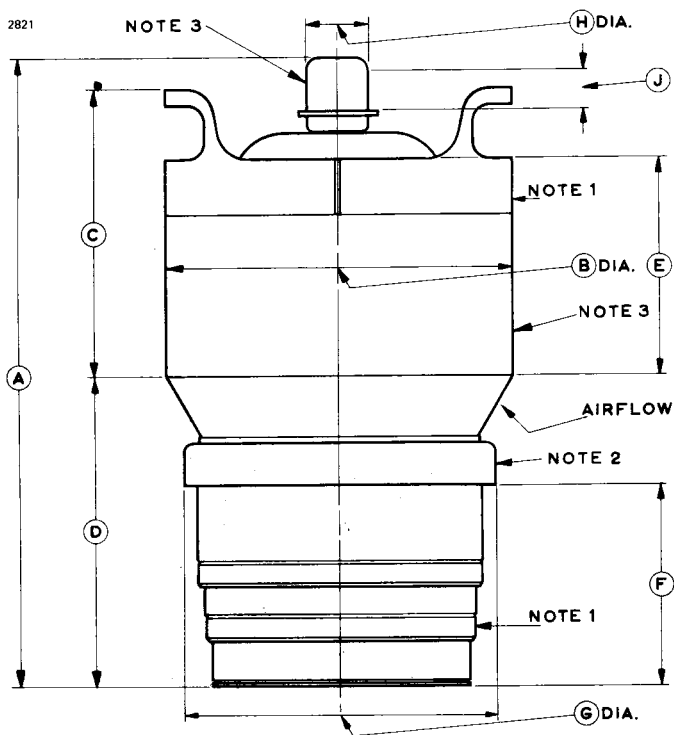

Ref	Inches	Millimetres
A	8.875 ± 0.250	225.4 ± 6.4
B	4.875 ± 0.062	123.8 ± 1.6
C	4.062 ± 0.188	103.2 ± 4.8
D	4.375 ± 0.188	111.1 ± 4.8
E	3.062 ± 0.188	77.77 ± 4.80
F	2.750 ± 0.188	69.85 ± 4.80
G	4.425 max	112.4 max
H	0.875 ± 0.020	22.23 ± 0.51
J	0.375 min	9.53 min

Millimetre dimensions have been derived from inches.

OUTLINE DETAILS

2822

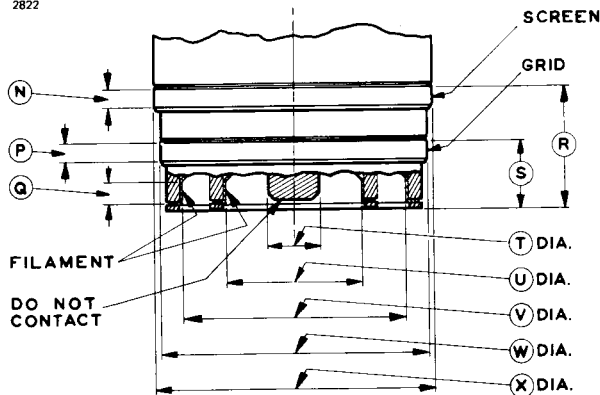

Ref	Inches	Millimetres
N	0.188 min	4.78 min
P	0.188 min	4.78 min
Q	0.188 min	4.78 min
R	1.795 ± 0.031	45.59 ± 0.79
S	1.018 ± 0.032	25.86 ± 0.81
T	0.740 ± 0.020	18.80 ± 0.51
U	1.916 ± 0.020	48.67 ± 0.51
V	3.153 ± 0.020	80.09 ± 0.51
W	3.812 ± 0.020	96.82 ± 0.51
X	4.000 ± 0.020	101.6 ± 0.5

Millimetre dimensions have been derived from inches.

Outline Notes

1. The eccentricity of the screen and filament contact surfaces will not exceed 0.040 inch (1.02mm) with respect to the anode and control grid contact surfaces when the valve is rotated on rollers at the points indicated by the arrows.
2. This surface must not be used as an electrical contact and it must not be clamped in any way.
3. This surface may be used for making electrical contact to the anode.

OUTLINE OF AIR DISTRIBUTION SOCKET MA87

2826

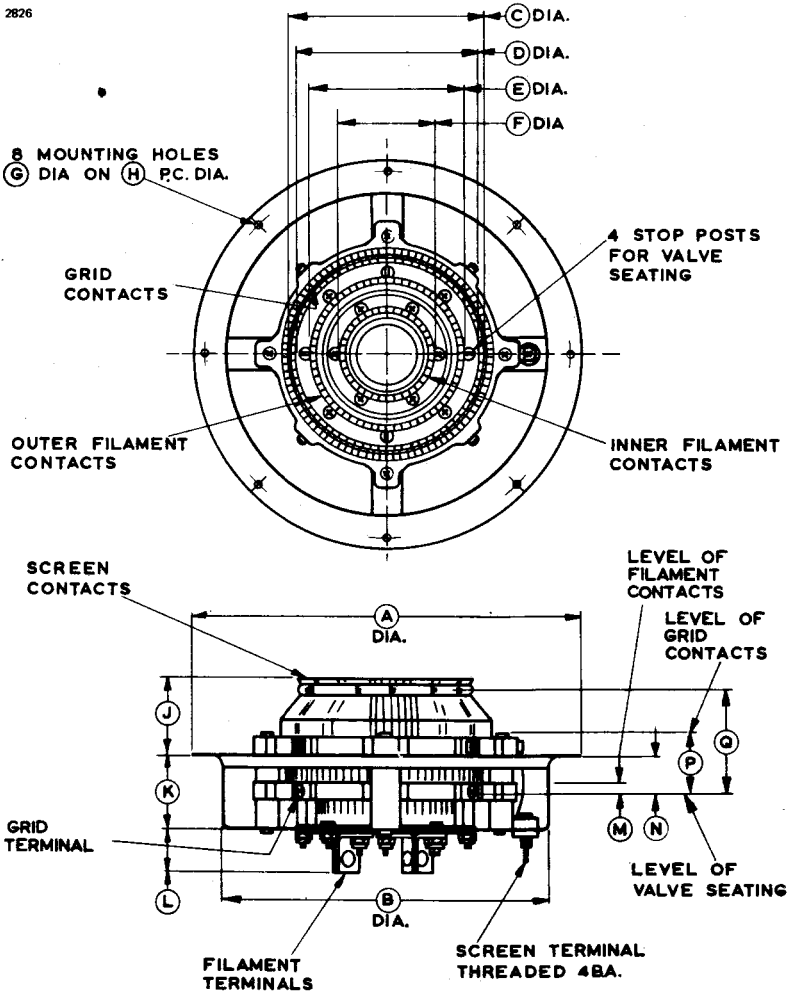

OUTLINE DETAIL OF MA87
View from underside showing terminals

2627

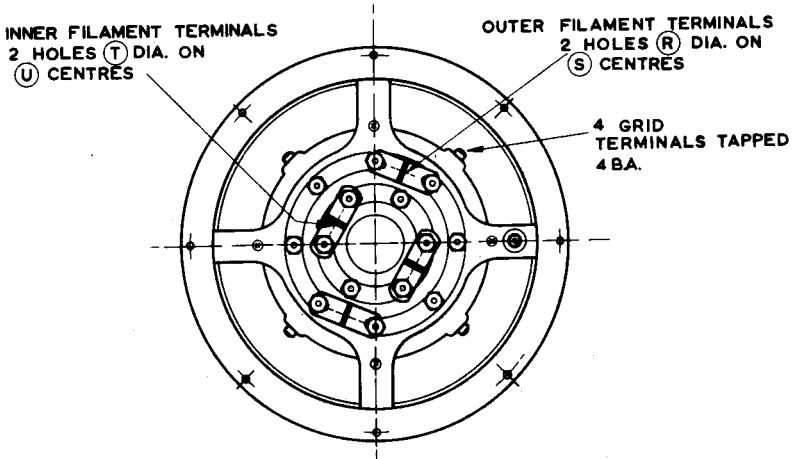

Ref	Inches	Millimetres	Ref	Inches	Millimetres
A	8.266 max	210.0 max	L	0.894 ± 0.031	22.71 ± 0.79
B	6.766 max	171.9 max	M	0.228 ± 0.012	5.79 ± 0.30
C	3.910 ± 0.030	99.31 ± 0.76	N	0.672 ± 0.017	17.07 ± 0.43
D	3.702 ± 0.030	94.03 ± 0.76	P	0.841 ± 0.015	21.36 ± 0.38
E	3.281 ± 0.030	83.34 ± 0.76	Q	1.626 ± 0.031	41.30 ± 0.79
F	2.031 ± 0.030	51.59 ± 0.76	R	0.250 ± 0.015	6.35 ± 0.38
G	0.147	3.73	S	1.562 ± 0.015	39.67 ± 0.38
H	7.750	196.9	T	0.250 ± 0.015	6.35 ± 0.38
J	1.125 ± 0.015	28.58 ± 0.38	U	0.937 ± 0.015	23.80 ± 0.38
K	1.489 ± 0.028	37.82 ± 0.71			

Millimetre dimensions have been derived from inches.

OUTLINE OF AIR CHIMNEY MA104
(All dimensions without limits are nominal)

2828

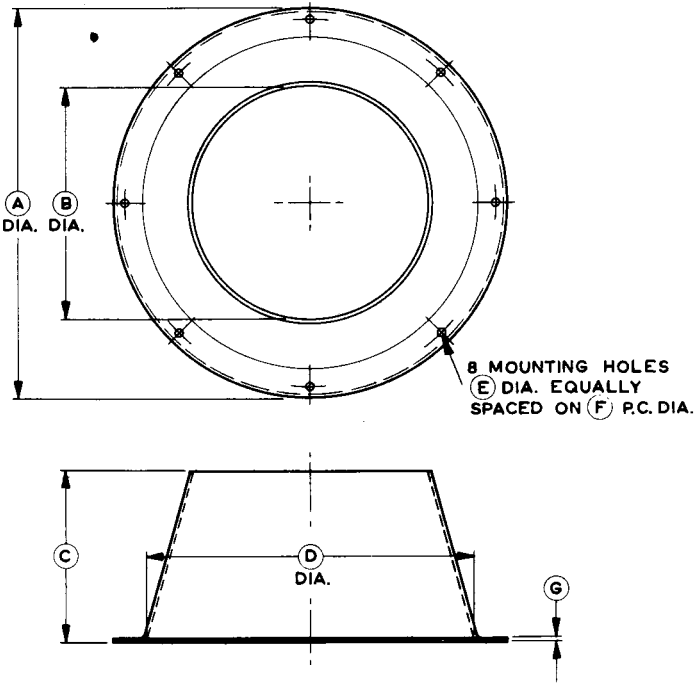

Ref	Inches	Millimetres
A	8.250	209.6
B	4.891 ^{+ 0.062} - 0.000	124.2 ^{+ 1.57} - 0.00
C	3.437	87.30
D	6.750	171.5
E	0.157	4.00
F	7.750	196.8
G	0.062	1.57

Millimetre dimensions have been derived from inches except dimension E.



4CX10,000D

R.F. POWER TETRODE

Service Type CV6184

The data should be read in conjunction with the Power Tetrode Preamble.

ABRIDGED DATA

Forced-air cooled tetrode, coaxial metal-ceramic envelope, for audio, linear single sideband, or screen-modulated r.f. amplifiers.

Anode dissipation (class C telegraphy)	10	kW max
Anode voltage	7.5	kV max
Frequency for full ratings	30	MHz max
Frequency at reduced ratings	110	MHz max
Output power (class C telegraphy)	16	kW

GENERAL

Electrical

Filament		thoriated tungsten
Filament voltage (see note 1)	7.5	V
Filament current	75	A
Grid-screen amplification factor ($V_a = 2.0kV$, $V_{g2} = 750V$, $I_a = 1.0A$)	4.5	

Inter-electrode capacitances:	Grounded Filament		Grounded Grid and Screen		
	Min	Max	Min	Max	
input	108	122	48	58	pF
output	18	23	18	23	pF
feedback	—	1.0	—	0.16	pF

Mechanical

Overall length	9.125 inches (232mm) max
Overall diameter	7.050 inches (179.1mm) max
Net weight	12.2 pounds (5.5kg) approx
Mounting position	vertical, either way up

COOLING

Sufficient air must be passed over the concentric base terminals and through the radiator fins to maintain the temperatures of the ceramic to metal seals and the radiator core below the maximum rated value of 250°C. It is recommended that an air distribution socket MA87 and chimney type MA104A be used with the tube (see pages 10, 11 and 12).

The air flows required with the recommended air socket and chimney to maintain the seal temperatures at 200°C in an ambient temperature of 50°C at sea level and with an operating frequency of less than 30MHz are given

below. At higher ambient temperatures, altitudes or frequencies the rate of flow must be adjusted to give equivalent cooling and should be determined individually in each case. An allowance of 1000 watts for the power dissipated by the filament and grids has been made in the values given.

Anode, dissipation (kW)	Air flow		Water pressure drop	
	ft ³ /min	m ³ /min	inches	mm
4.0	110	3.1	0.4	10.2
6.0	200	5.7	0.8	20.4
8.0	315	8.9	1.7	43
10	445	12.6	2.8	71
12	600	17.0	4.4	110

AUDIO FREQUENCY POWER AMPLIFIER OR MODULATOR (Class AB1) (See Note 2)

MAXIMUM RATINGS (Absolute values)

Anode voltage	7.5	kV max
Anode current	4.0	A max
Anode dissipation	12	kW max
Screen voltage	1.5	kV max
Screen dissipation	250	W max
Grid dissipation	75	W max

TYPICAL OPERATING CONDITIONS (Class AB1, two valves)

Anode voltage	4.0	5.0	6.0	7.5	kV
Screen voltage	1.5	1.5	1.5	1.5	kV
Grid voltage	-315	-320	-330	-340	V
Peak a.f. voltage, grid to grid	305	310	320	330	V
Anode current (zero signal)	1.0	1.0	1.0	1.0	A
Anode current (max. signal)	6.66	6.66	6.66	6.66	A
Screen current (zero signal)	0	0	0	0	A
Screen current (max. signal)	0.33	0.32	0.30	0.25	A
Anode dissipation (maximum signal)	6.67	7.95	8.10	9.05	kW
Effective load (anode to anode)	0.94	1.32	1.70	2.28	kΩ
Nominal driving power (maximum signal)	0	0	0	0	W
Output power (max. signal)	13.3	17.5	23.8	31.9	kW

RADIO FREQUENCY LINEAR AMPLIFIER

(Class AB1) (See Note 2)

MAXIMUM RATINGS (Absolute values)

Anode voltage	7.5	kV max
Anode current	4.0	A max
Anode dissipation	12	kW max
Screen voltage	1.5	kV max
Screen dissipation	250	W max
Grid dissipation	75	W max

TYPICAL OPERATING CONDITIONS

(Peak envelope or modulation crest conditions, below 30MHz)

Anode voltage	7.5	kV
Screen voltage	1.5	kV
Grid voltage (see note 3)	-340	V
Peak r.f. grid voltage	330	V
Anode current (zero signal)	0.50	A
Anode current (maximum signal)	3.33	A
Screen current (maximum signal)	0.125	A
Anode dissipation	9.05	kW
Nominal driving power	0	W
Output power (see note 4)	15.95	kW

ANODE MODULATED R.F. POWER AMPLIFIER

(Class C Telephony, carrier conditions per valve for use with a maximum modulation factor of 1.0)

MAXIMUM RATINGS (Absolute values)

Anode voltage	5.0	kV max
Anode current	2.5	A max
Anode dissipation (see note 5)	6.65	kW max
Screen voltage	1.0	kV max
Screen dissipation	250	W max
Grid dissipation	75	W max

TYPICAL OPERATING CONDITIONS (below 30MHz)

Anode voltage	5.0	kV
Screen voltage	500	V
Grid voltage	-400	V
Peak a.f. screen voltage (for 100% modulation)	450	V
Peak r.f. grid voltage	520	V
Anode current	1.4	A
Screen current	0.26	A
Grid current	0.05	A
Anode dissipation	1.1	kW
Nominal driving power	25	W
Output power	5.8	kW

R.F. POWER AMPLIFIER OR OSCILLATOR
(Class C Telegraphy, key down conditions, one valve)

MAXIMUM RATINGS (Absolute values)

	Up to 30MHz	30-60MHz	60-110MHz	
Anode voltage	7.5	7.0	6.5	kV max
Anode current	3.0	2.8	2.6	A max
Anode dissipation	10	10	10	kW max
Screen voltage	1.5	1.5	1.5	kV max
Screen dissipation	250	250	250	W max
Grid dissipation	75	75	75	W max

TYPICAL OPERATING CONDITIONS (below 30MHz)

Anode voltage	7.5	kV
Screen voltage	500	V
Grid voltage	-350	V
Peak r.f. grid voltage	590	V
Anode current	2.8	A
Screen current	0.5	A
Grid current	0.25	A
Anode dissipation	5.0	kW
Nominal driving power	150	W
Output power	16	kW

NOTES

1. The valve must be operated at the stated filament voltage. Fluctuation in filament voltage must not exceed $\pm 5\%$.
2. Grid current does not flow during any part of the audio frequency cycle.
3. The grid voltage is adjusted to obtain the specified zero-signal anode current.
4. The peak envelope or r.f. output power at the crest of the modulation envelope.
5. This corresponds to 10kW anode dissipation at 100% sine wave modulation.

TYPICAL CONSTANT CURRENT CHARACTERISTICS

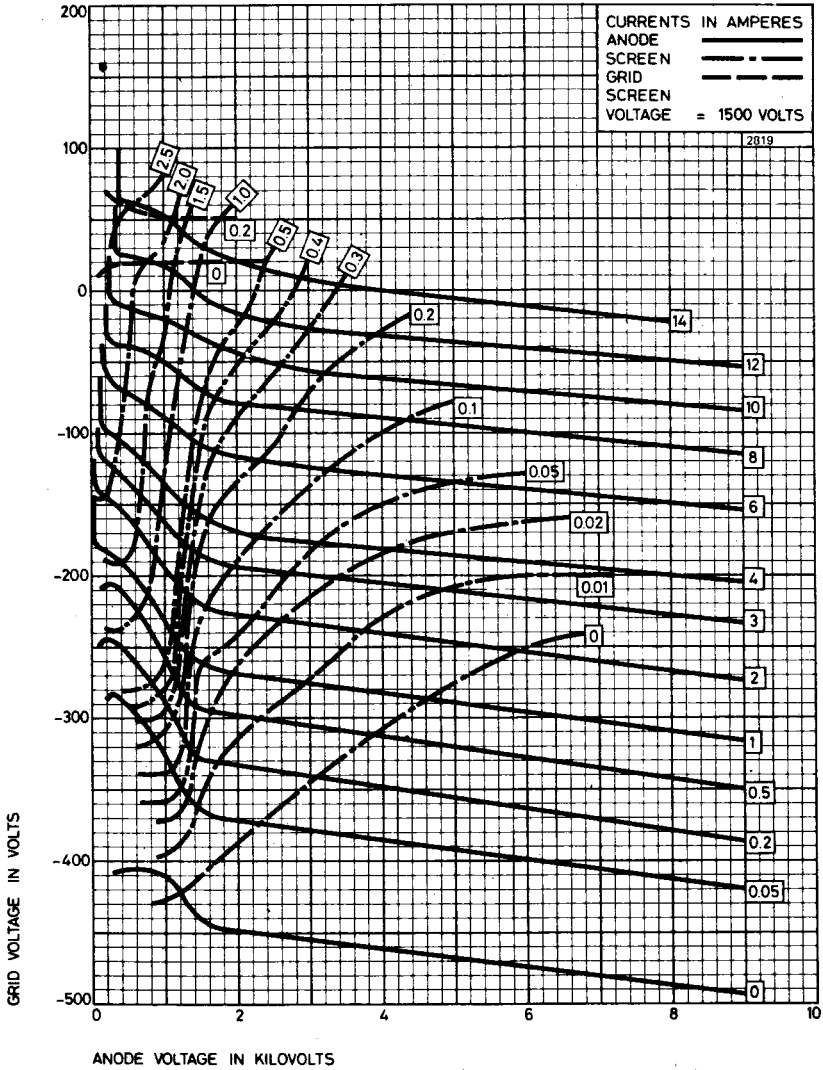

TYPICAL CONSTANT CURRENT CHARACTERISTICS

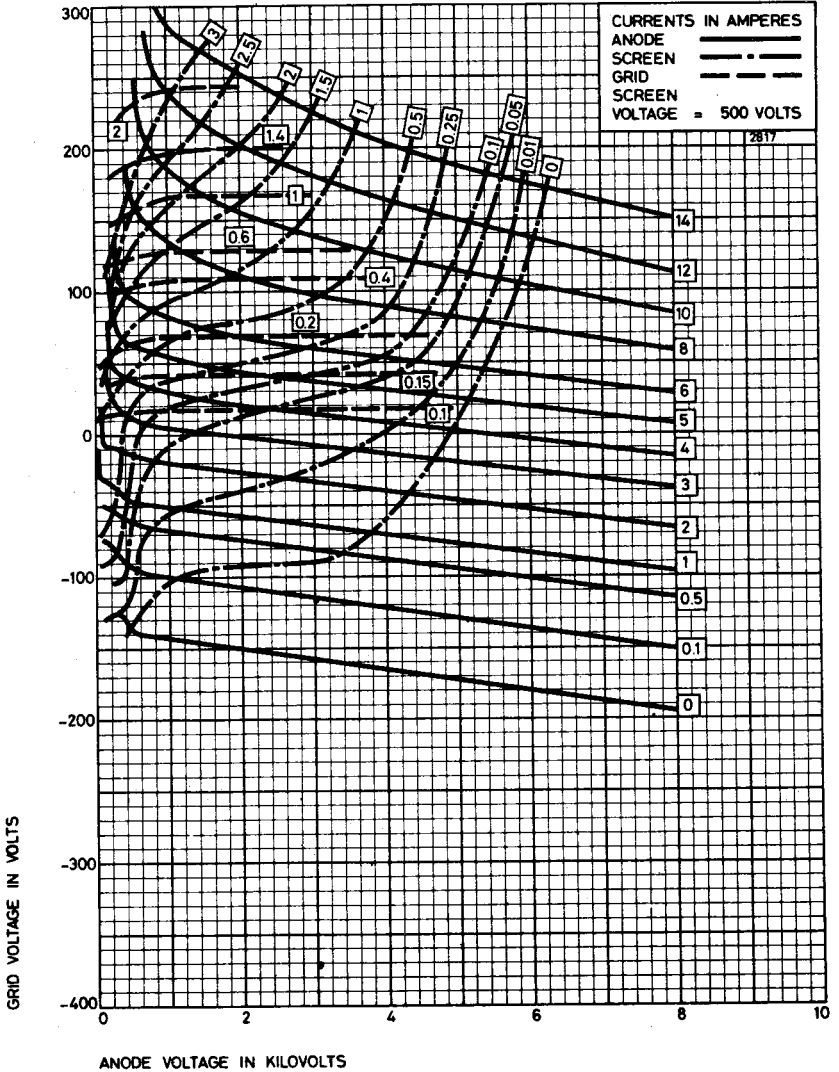

OUTLINE

2823

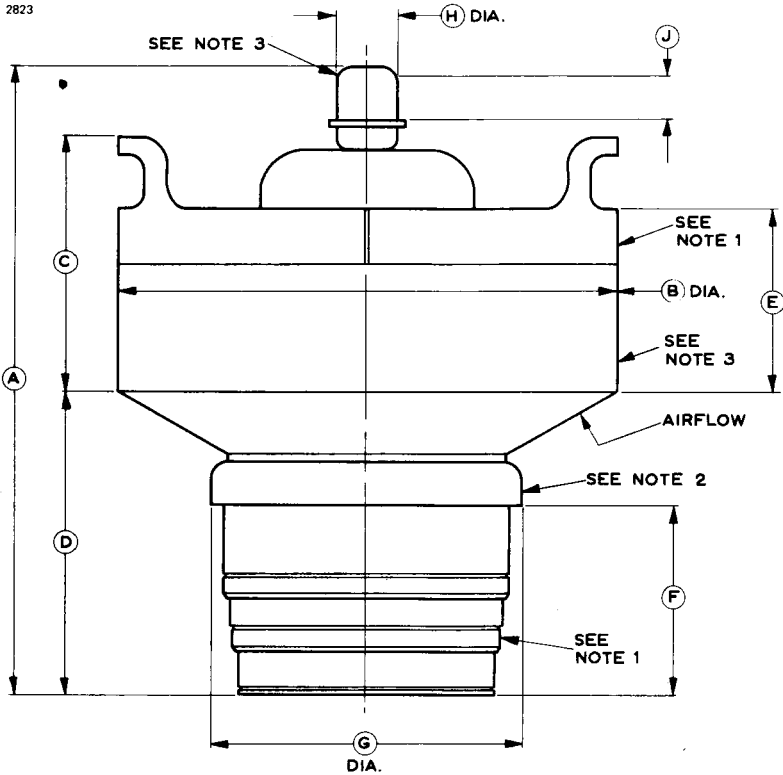

Ref	Inches	Millimetres
A	8.875 ± 0.250	225.4 ± 6.4
B	6.989 ± 0.062	177.5 ± 1.6
C	3.600 ± 0.188	91.44 ± 4.80
D	4.375 ± 0.188	111.1 ± 4.8
E	2.600 ± 0.188	66.04 ± 4.80
F	2.750 ± 0.188	69.85 ± 4.80
G	4.425 max	112.4 max
H	0.875 ± 0.020	22.23 ± 0.51
J	0.375 min	9.53 min

Millimetre dimensions have been derived from inches.

OUTLINE DETAILS

2822

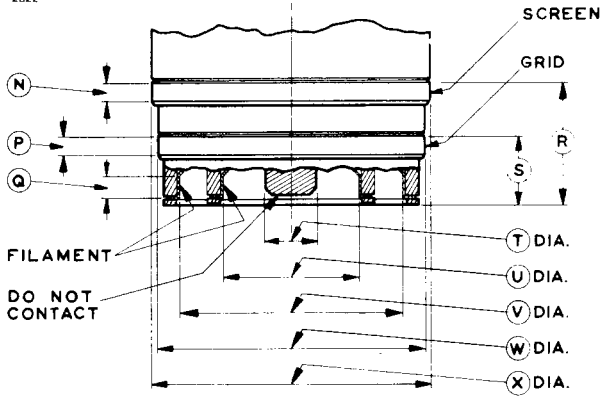

Ref	Inches	Millimetres
N	0.188 min	4.78 min
P	0.188 min	4.78 min
Q	0.188 min	4.78 min
R	1.795 ± 0.031	45.59 ± 0.79
S	1.018 ± 0.032	25.86 ± 0.81
T	0.740 ± 0.020	18.80 ± 0.51
U	1.916 ± 0.020	48.67 ± 0.51
V	3.153 ± 0.020	80.09 ± 0.51
W	3.812 ± 0.020	96.82 ± 0.51
X	4.000 ± 0.020	101.6 ± 0.5

Millimetre dimensions have been derived from inches.

Outline Notes

1. The eccentricity of the screen and filament contact surfaces will not exceed 0.040 inch (1.02mm) with respect to the anode and control grid contact surfaces when the valve is rotated on rollers at the points indicated by the arrows.
2. This surface must not be used as an electrical contact and it must not be clamped in any way.
3. This surface may be used for making electrical contact to the anode.

OUTLINE OF AIR DISTRIBUTION SOCKET MA87

2826

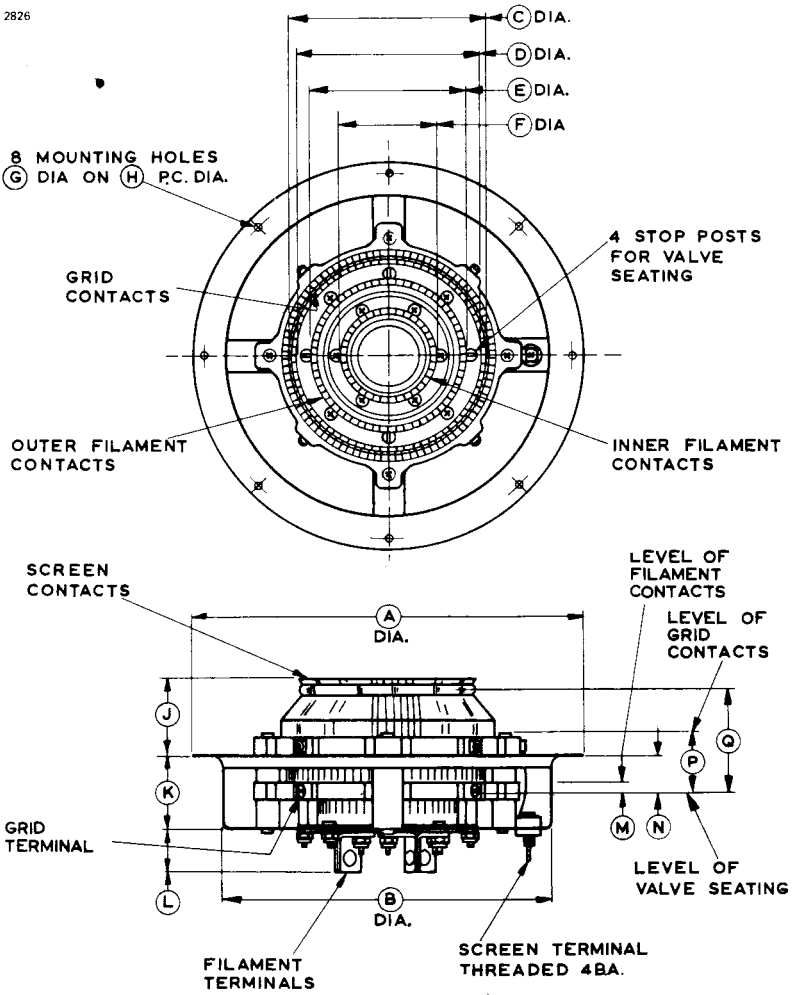

OUTLINE DETAIL OF MA87

View from underside showing terminals

2827

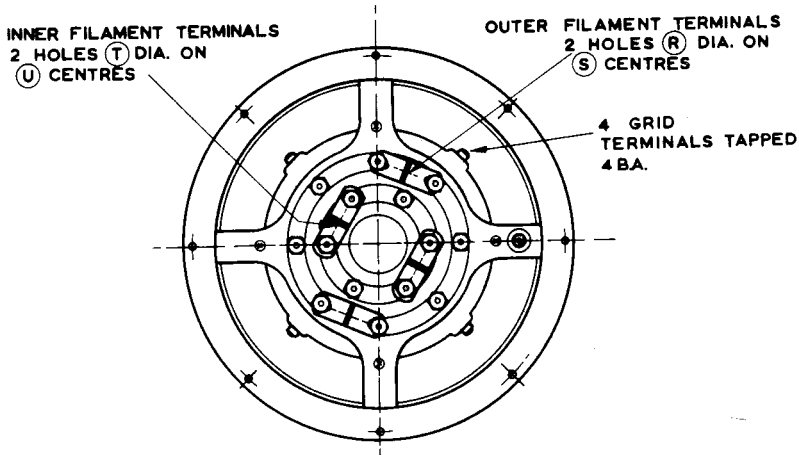

Ref	Inches	Millimetres	Ref	Inches	Millimetres
A	8.266 max	210.0 max	L	0.894 ± 0.031	22.71 ± 0.79
B	6.766 max	171.9 max	M	0.228 ± 0.012	5.79 ± 0.30
C	3.910 ± 0.030	99.31 ± 0.76	N	0.672 ± 0.017	17.07 ± 0.43
D	3.702 ± 0.030	94.03 ± 0.76	P	0.841 ± 0.015	21.36 ± 0.38
E	3.281 ± 0.030	83.34 ± 0.76	Q	1.626 ± 0.031	41.30 ± 0.79
F	2.031 ± 0.030	51.59 ± 0.76	R	0.250 ± 0.015	6.35 ± 0.38
G	0.147	3.73	S	1.562 ± 0.015	39.67 ± 0.38
H	7.750	196.9	T	0.250 ± 0.015	6.35 ± 0.38
J	1.125 ± 0.015	28.58 ± 0.38	U	0.937 ± 0.015	23.80 ± 0.38
K	1.489 ± 0.028	37.82 ± 0.71			

Millimetre dimensions have been derived from inches.

OUTLINE OF AIR CHIMNEY MA 104A
 (All dimensions without limits are nominal)

2829

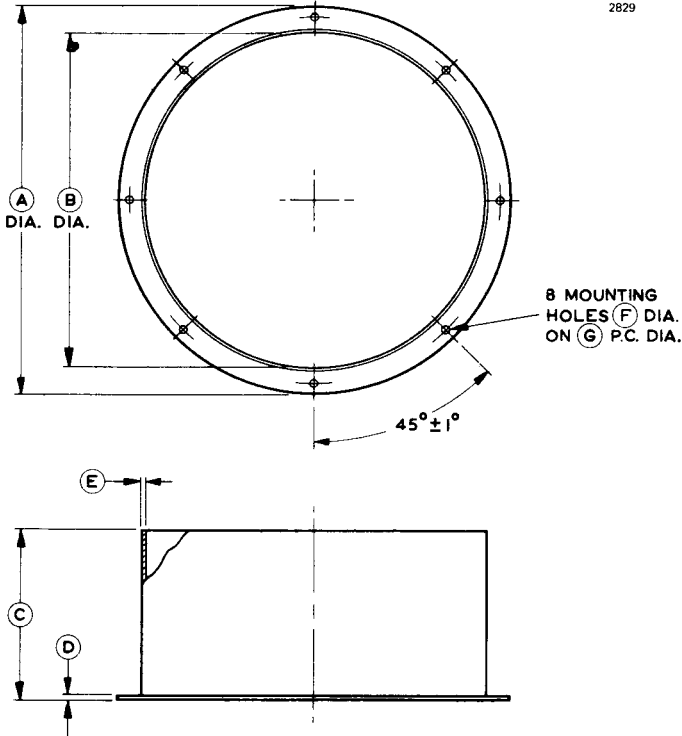

Ref	Inches	Millimetres
A	8.250	209.6
B	7.000 ^{+0.062} -0.000	177.8 ^{+1.57} -0.00
C	3.625	92.08
D	0.093	2.36
E	0.125 ± 0.031	3.18 ± 0.79
F	0.157	4.00
G	7.750	196.8

Millimetre dimensions have been derived from inches except dimension F.



4CX35,000C

R.F. POWER TETRODE

Service Type CV11107

The data should be read in conjunction with the Power Tetrode Preamble.

ABRIDGED DATA

Forced-air cooled tetrode, coaxial metal-ceramic envelope, for audio amplifiers, r.f. linear amplifiers or class C amplifiers or oscillators.

Anode dissipation (class C telegraphy)	35	kW max
Anode voltage	20	kV max
Frequency for full ratings	30	MHz max
Output power (class C telegraphy)	82.5	kW

GENERAL

Electrical

Filament	thoriated tungsten
Filament voltage (see note 1)	10 V
Filament current	300 A
Grid-screen amplification factor	4.5
Inter-electrode capacitances, grounded filament:	
grid to anode	2.4 pF
input	465 pF
output	55 pF

Mechanical

Overall length	17.500 inches (444.5mm) max
Overall diameter	9.750 inches (247.7mm) max
Net weight	50 pounds (23kg) approx
Mounting position	vertical, either way up

Accessories

Sockets (see pages 10-12)	MA166A or MA166B
Clamping device to secure valve in socket (optional)	MA233

COOLING

Sufficient air must be passed over the base terminals and through the radiator fins to maintain the temperatures of the ceramic to metal seals and the radiator core below the maximum rated value of 250°C.

Using socket type MA166 or MA166B, 60 to 100ft³/min (1.70 to 2.83m³/min) of air will be required for base cooling. This should be blown horizontally through the socket from two diametrically opposed nozzles. It is also necessary to direct 2ft³/min (0.06m³/min) of air into the centre hole of the socket.

The air flows required to maintain the seal and radiator core temperatures at 225°C in an ambient temperature of 40°C at sea level and with an operating frequency of less than 30MHz are given below. The values specified are for air flowing in the direction from base to anode. At higher ambient temperatures or altitudes the rate of flow must be adjusted to give equivalent cooling and should be determined individually in each case. An allowance of 5250 watts for the power dissipated by the filament and grids has been made in the values given.

Anode dissipation (kW)	Air flow		Water pressure drop	
	ft ³ /min	m ³ /min	inches	mm
15	485	13.7	1.65	4.2
20	710	20.1	2.85	7.25
25	1000	28.3	5.1	13.0
30	1320	37.4	8.9	22.6
35	1650	46.7	14.5	36.8

AUDIO FREQUENCY POWER AMPLIFIER OR MODULATOR

(Class AB1) (See Note 2)

MAXIMUM RATINGS (Absolute values)

Anode voltage	20	kV max
Anode current	15	A max
Anode dissipation	35	kW max
Screen voltage	2.5	kV max
Screen dissipation	1750	W max
Grid dissipation	500	W max
Grid circuit resistance	0.1	MΩ max

TYPICAL OPERATING CONDITIONS (Class AB1, two valves)

Anode voltage	10	15	kV
Screen voltage	1.5	1.5	kV
Grid voltage	-290	-340	V
Peak a.f. voltage, grid to grid	270	310	V
Anode current (zero signal)	4.0	2.0	A
Anode current (maximum signal)	17.4	15.1	A
Screen current (zero signal)	0	0	A
Screen current (maximum signal)	0.77	0.62	A
Anode dissipation per tube (maximum signal)	33	30.5	kW
Effective load (anode to anode)	1.15	2.56	k Ω
Nominal driving power (maximum signal)	0	0	W
Output power (maximum signal)	110	165	kW

**RADIO FREQUENCY LINEAR AMPLIFIER
(Class AB1) (See Note 2)**

MAXIMUM RATINGS (Absolute values)

Anode voltage	20	kV max
Anode current	15	A max
Anode dissipation	35	kW max
Screen voltage	2.5	kV max
Screen dissipation	1750	W max
Grid dissipation	500	W max
Grid circuit resistance	0.1	M Ω max

TYPICAL OPERATING CONDITIONS

(Peak envelope or modulation crest conditions, below 30MHz)

Anode voltage	10	15	kV
Screen voltage	1.5	1.5	kV
Grid voltage (see note 3)	-290	-340	V
Peak r.f. grid drive voltage	270	310	V
Anode current (zero signal)	2.0	1.0	A
Anode current (maximum signal)	8.7	7.55	A
Screen current (maximum signal)	0.385	0.310	A
Anode dissipation	33	30.5	kW
Nominal driving power	0	0	W
Output power (see note 4)	55	82.5	kW

ANODE MODULATED R.F. POWER AMPLIFIER

(Class C Telephony, carrier conditions per valve for use with a maximum modulation factor of 1.0)

MAXIMUM RATINGS (Absolute values)

Anode voltage	17.5	kV max
Anode current	15	A max
Anode dissipation (see note 5)	23	kW max
Screen voltage	2.0	kV max
Screen dissipation	1750	W max
Grid dissipation	500	W max

TYPICAL OPERATING CONDITIONS (below 30MHz)

Anode voltage	7.5	10	15	kV
Screen voltage	750	750	750	V
Grid voltage	-460	-520	-540	V
Peak a.f. screen voltage (for 100% modulation)	640	675	630	V
Peak r.f. grid drive voltage	630	680	700	V
Anode current	7.0	6.6	6.45	A
Screen current	1.2	0.985	0.890	A
Grid current	0.375	0.370	0.355	A
Anode dissipation	10.5	11.0	14.5	kW
Nominal driving power	235	250	250	W
Output power	42	55	82.5	kW

R.F. POWER AMPLIFIER OR OSCILLATOR

(Class C Telegraphy, key down conditions, one valve)

MAXIMUM RATINGS (Absolute values)

Anode voltage	20	kV max
Anode current	15	A max
Anode dissipation	35	kW max
Screen voltage	2.5	kV max
Screen dissipation	1750	W max
Grid dissipation	500	W max

TYPICAL OPERATING CONDITIONS (below 30MHz)

Anode voltage	10	15	kV
Screen voltage	750	750	V
Grid voltage	-425	-480	V
Peak r.f. grid drive voltage	575	640	V
Anode current	6.70	6.45	A
Screen current	0.925	0.810	A
Grid current	0.320	0.355	A
Anode dissipation	12	14	kW
Nominal driving power	185	225	W
Output power	55	82.5	kW

NOTES

1. The valve must be operated at the stated filament voltage. Fluctuation in filament voltage must not exceed $\pm 5\%$.
2. Grid current does not flow during any part of the drive cycle.
3. The grid voltage is adjusted to obtain the specified zero-signal anode current.
4. The peak envelope or r.f. output power at the crest of the modulation envelope.
5. This corresponds to an anode dissipation of 35kW at 100% sine wave modulation.

TYPICAL CONSTANT CURRENT CHARACTERISTICS

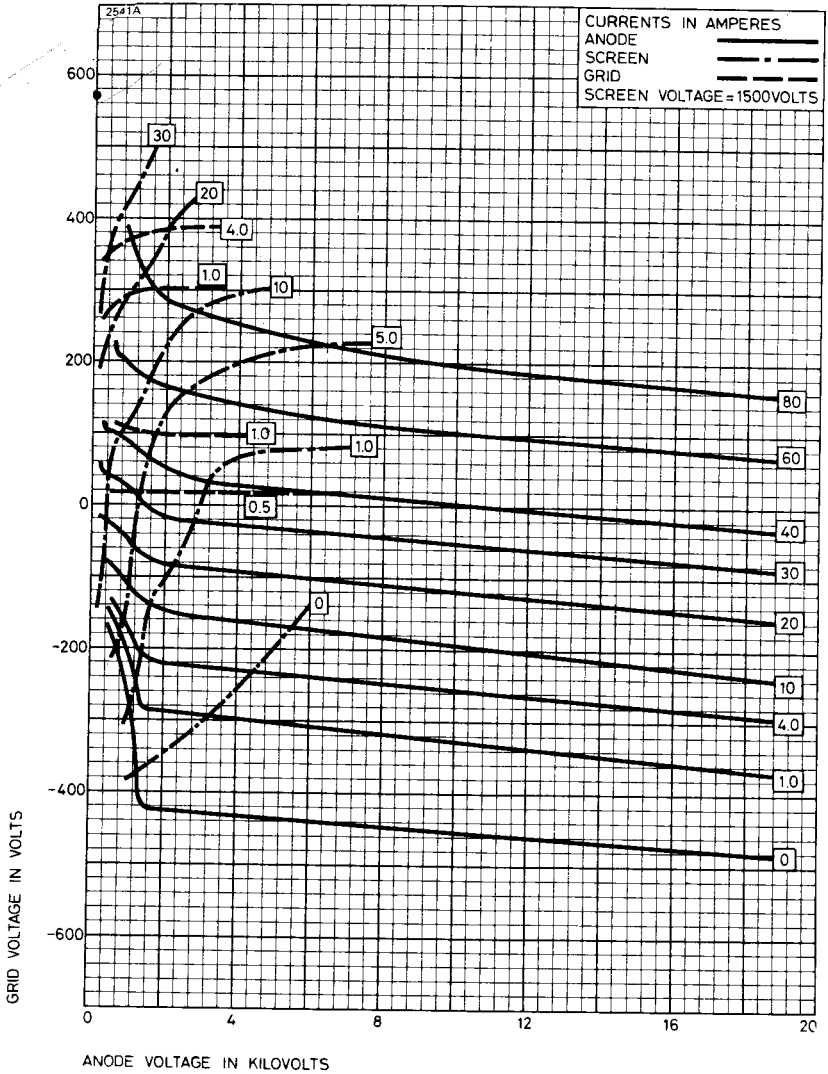

TYPICAL CONSTANT CURRENT CHARACTERISTICS

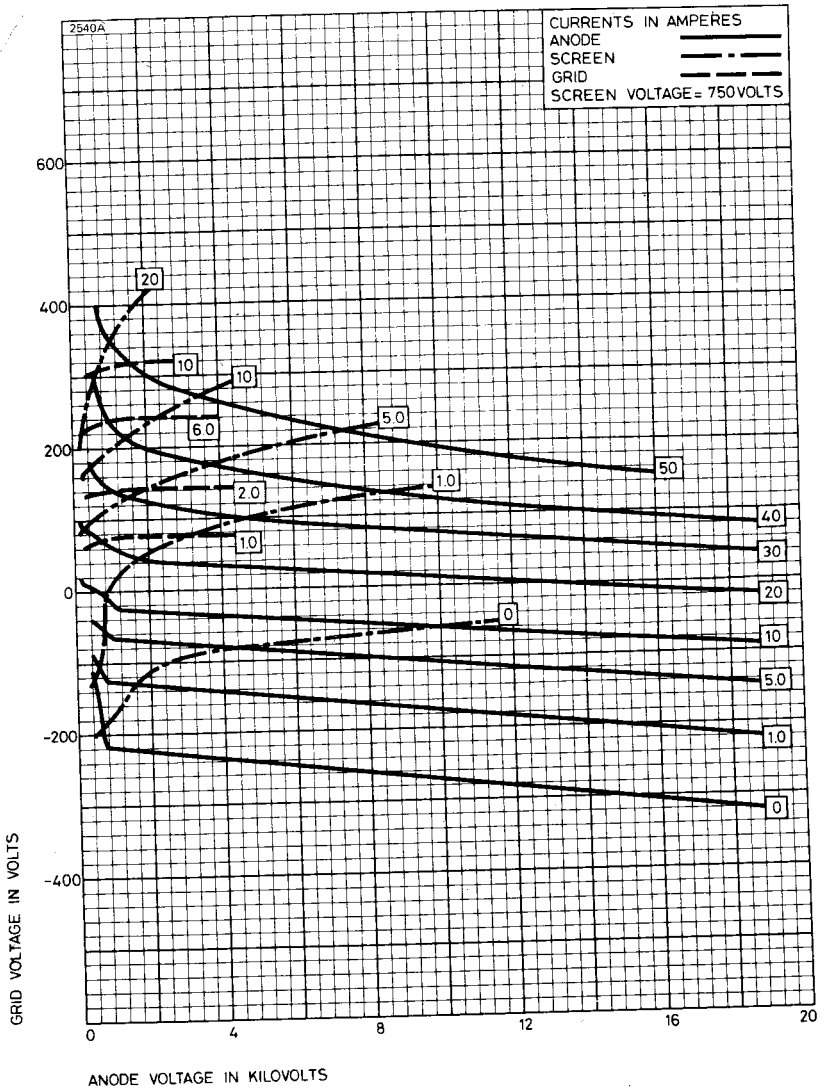

OUTLINE (All dimensions without limits are nominal)

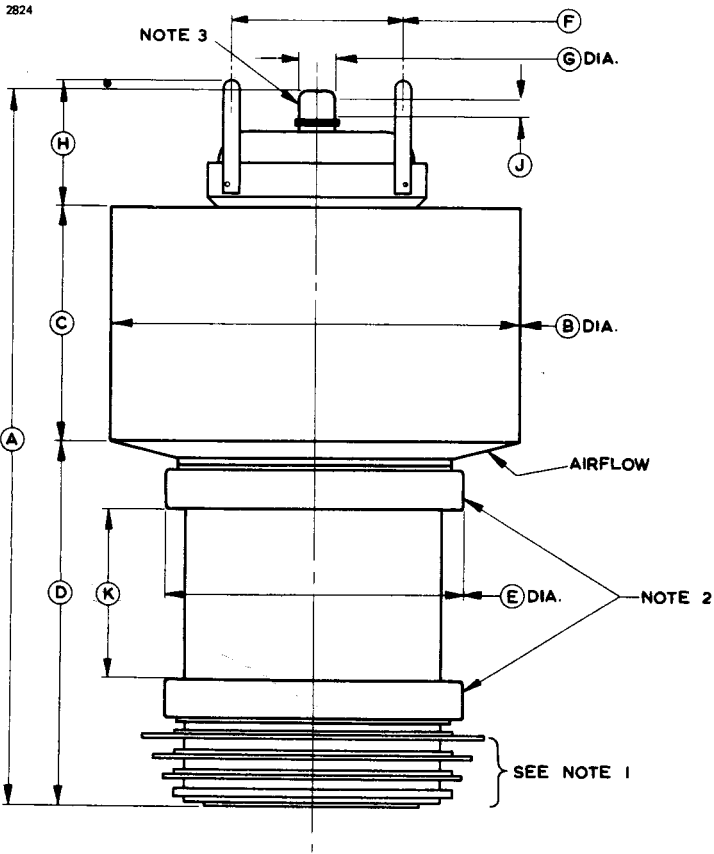

Ref	Inches	Millimetres	Ref	Inches	Millimetres
A	16.855 ± 0.125	428.1 ± 3.2	F	4.000	101.6
B	9.625 ± 0.125	244.5 ± 3.2	G	0.875 ± 0.015	22.23 ± 0.38
C	5.500 ± 0.125	139.7 ± 3.2	H	3.062	77.78
D	8.567 ± 0.125	217.6 ± 3.2	J	0.500 ± 0.015	12.70 ± 0.38
E	7.062 max	179.4 max	K	4.000 min	101.6 min

Millimetre dimensions have been derived from inches.

OUTLINE DETAIL

2825

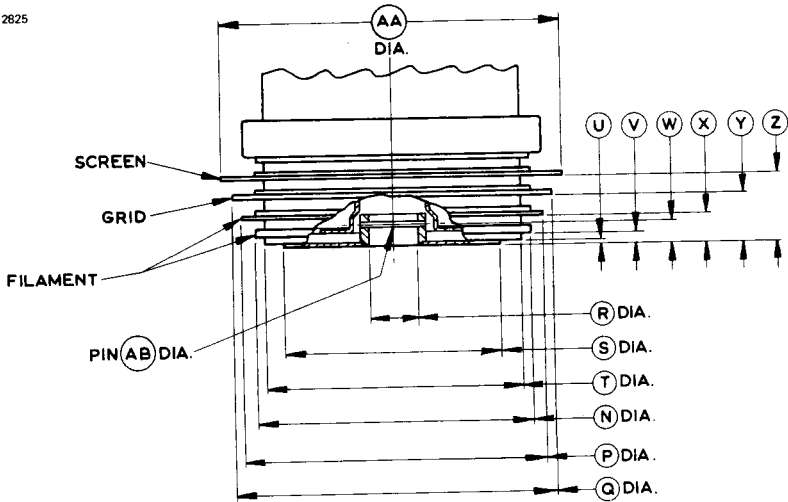

Ref	Inches	Millimetres	Ref	Inches	Millimetres
N	6.530 ± 0.030	165.9 ± 0.8	V	0.197 ± 0.031	5.00 ± 0.79
P	7.000 ± 0.020	177.8 ± 0.5	W	0.510 ± 0.020	12.95 ± 0.51
Q	7.500 ± 0.020	190.5 ± 0.5	X	0.715 ± 0.025	18.16 ± 0.64
R	1.260 ± 0.010	32.00 ± 0.25	Y	1.245 ± 0.025	31.62 ± 0.64
S	5.000 ± 0.020	127.0 ± 0.5	Z	1.775 ± 0.025	45.08 ± 0.64
T	6.000 ± 0.020	152.4 ± 0.5	AA	7.995 ± 0.020	203.1 ± 0.5
U	0.060 ± 0.015	1.52 ± 0.38	AB	0.135	3.43

Millimetre dimensions have been derived from inches.

Outline Notes

1. The eccentricity of the filament, grid and screen contact surfaces will not exceed 0.125 inch (3.18mm) with respect to dimension R with the tube mounted on the bottom ceramic.
2. These surfaces must not be used for electrical contacts and must not be clamped in any way.
3. This surface may be used for making electrical contact to the anode.

OUTLINE OF SOCKETS MA166 AND MA166B
 (See pages 11 and 12 for plan views)

2543

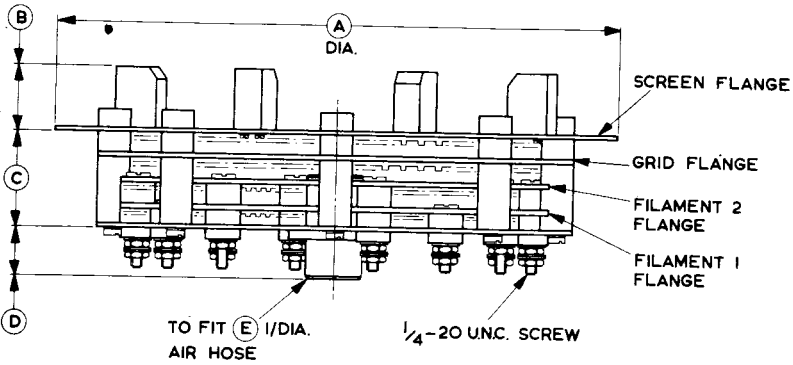

Ref	Inches	Millimetres
A	12.000 ± 0.015	304.8 ± 0.4
B	1.250 ± 0.156	31.75 ± 3.96
C	2.000 ± 0.020	50.80 ± 0.51
D	1.000 ± 0.020	25.40 ± 0.51
E	1.250	31.75
F	0.437	11.10
G	11.250	285.8
H	0.187	4.75
J	11.250	285.8
K	8.530	216.7
L	10.125 ± 0.031	257.2 ± 0.8
M	0.312	7.92
N	4.813	122.3

Millimetre dimensions have been derived from inches.

All dimensions without limits are nominal

Outline Detail of MA 166 (See page 10 for dimensions)

2544

6 HOLES (F) DIA.
EQUALLY SPACED
ON (G) P.C.DIA.

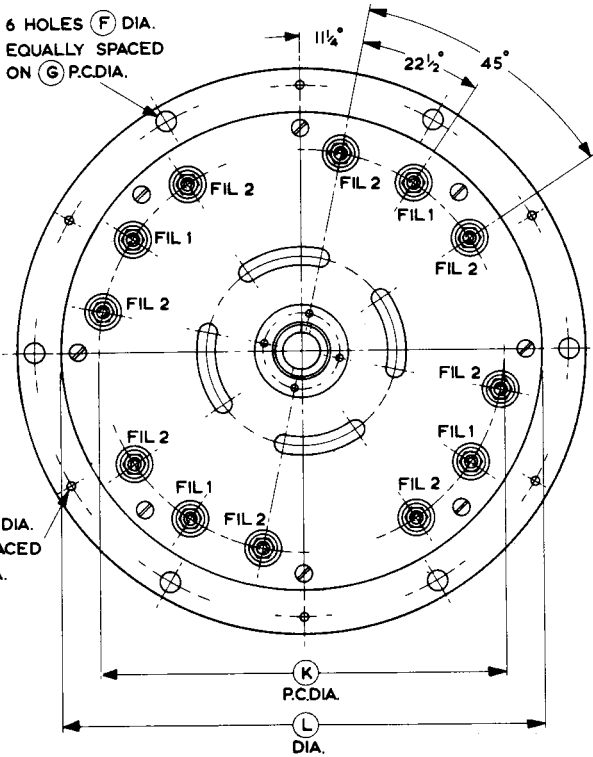

6 HOLES (H) DIA.
EQUALLY SPACED
ON (J) P.C.DIA.



Outline Detail of MA166B (See page 10 for dimensions)

2830A

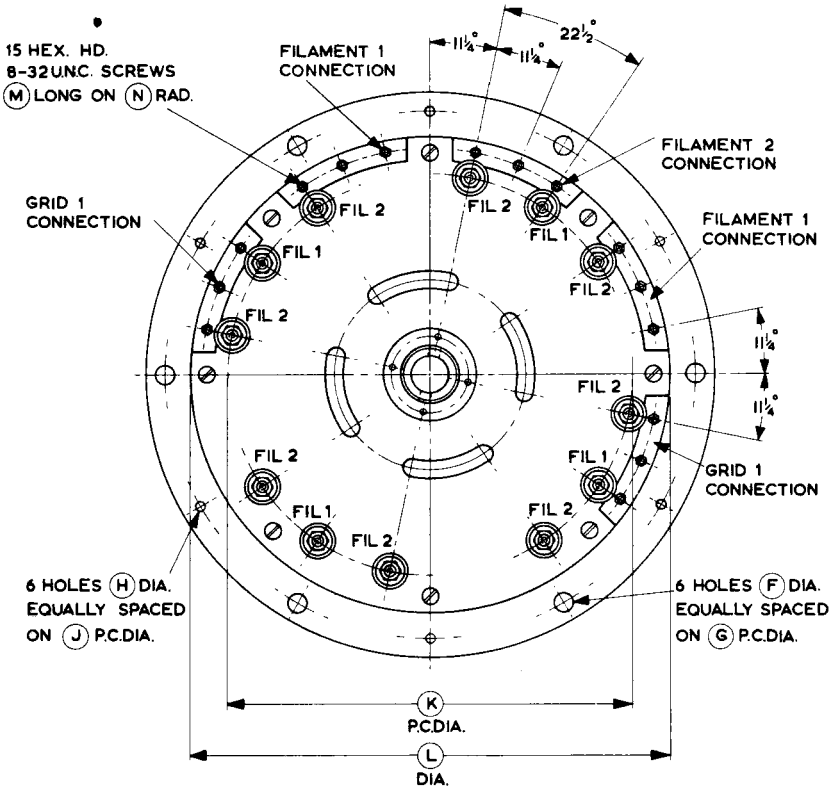



6166A/7007

V.H.F. POWER TETRODE

The data should be read in conjunction with the Power Tetrode Preamble.

ABRIDGED DATA

Forced-air cooled tetrode with coaxial metal-ceramic envelope, for television and other applications at frequencies up to 220MHz.

Anode dissipation	12	kW max
Anode voltage	7.5	kV max
Frequency for full ratings:		
class C telegraphy or f.m. telephony	60	MHz max
class B or class C television service	220	MHz max
Output power:		
television service (synchronising level)	12	kW
class C telegraphy or f.m. telephony (216MHz)	10	kW

GENERAL

Electrical

Filament		thoriated tungsten
Filament voltage (see note 1)	5.0	V
Filament current	175	A
Filament cold resistance	3.8	m Ω
Peak usable cathode current	20	A
Grid-screen amplification factor ($V_a = 2.0\text{kV}$, $V_{g2} = 1.0\text{kV}$, $I_a = 2.0\text{A}$)	10	
Mutual conductance ($V_a = 2.0\text{kV}$, $V_{g2} = 1.0\text{kV}$, $I_a = 2.0\text{A}$)	25	mA/V

Continued on page 2

Electrical (continued)

Inter-electrode capacitances:

grid to anode (see note 2)	0.6	pF max
grid to filament	44	pF
anode to filament (see note 2)	0.08	pF max
grid to screen grid	60	pF
screen grid to anode	21	pF

Mechanical

Overall length	11.500 inches (292.1mm) max
Overall diameter	6.380 inches (162.1mm) max
Net weight	17 pounds (7.8kg) approx
Mounting position	vertical, either way up

COOLING

The required quantity of air through the radiator for cooling the anode is indicated on the graphs (pages 17 and 18) and should be delivered by a blower through the radiator before and during the application of any voltages. It should enter at the envelope end and some of the flow should be used to cool the screen-grid seal.

In addition, a flow of about 50ft³/min (1.42m³/min) should be directed at the filament and grid terminals.

The temperature of anode, screen, grid and filament seals must not exceed 180°C.

Power and air supplies may be removed simultaneously.

R.F. POWER AMPLIFIER

(Class B Television Service, U.S.A. System)

(Synchronising-level conditions per valve unless otherwise specified. Voltages are referred to cathode unless otherwise specified)

MAXIMUM RATINGS (Absolute values) (up to 220MHz)

Anode voltage	7.5	kV max
Screen voltage	2.0	kV max
Anode current	4.0	A max
Anode input power	24	kW max
Screen input power	400	W max
Anode dissipation	12	kW max
Grid dissipation	300	W max

TYPICAL OPERATION IN GRID-DRIVE CIRCUIT**(at 216MHz and bandwidth 8.5MHz – see note 3)**

Anode voltage	5.8	kV
Screen voltage	1.2	kV
Grid voltage	-130	V
Peak r.f. grid voltage:		
synchronising level	375	V
pedestal level	290	V
Anode current:		
synchronising level	3.45	A
pedestal level	2.60	A
Screen current (pedestal level)	207	mA
Grid current (approx):		
synchronising level	175	mA
pedestal level	85	mA
Driving power (approx, see note 4):		
synchronising level (see note 5)	800	W
pedestal level	450	W
Output power (approx):		
synchronising level	12	kW
pedestal level	6.8	kW

TYPICAL OPERATION IN CATHODE-DRIVE CIRCUIT**(at 216MHz and bandwidth 8.5MHz – see note 3)**

Anode voltage	6.4	kV
Screen voltage	800	V
Grid voltage	-90	V
Peak r.f. grid voltage:		
synchronising level	360	V
pedestal level	285	V
Anode current:		
synchronising level	3.65	A
pedestal level	2.75	A
Screen current (pedestal level)	175	mA
Grid current (approx):		
synchronising level	240	mA
pedestal level	160	mA
Driving power (approx, see note 6):		
synchronising level (see note 7)	1.5	kW
pedestal level	850	W
Output power (approx):		
synchronising level	14	kW
pedestal level	7.9	kW

GRID-MODULATED R.F. POWER AMPLIFIER

(Class C Television Service, U.S.A. System)

(Synchronising-level conditions per valve unless otherwise specified)

MAXIMUM RATINGS (Absolute values) (up to 220MHz)

Anode voltage	7.5	kV max
Screen voltage	2.0	kV max
Grid voltage (white level)	-1.0	kV max
Anode current	4.0	A max
Anode input power	24	kW max
Screen input power	400	W max
Anode dissipation	12	kW max
Grid dissipation	300	W max

TYPICAL OPERATION IN GRID-DRIVE CIRCUIT

(at 216MHz and bandwidth 8.5MHz, See Note 3)

Anode voltage	5.8	kV
Screen voltage	1.2	kV
Grid voltage:		
synchronising level	-130	V
pedestal level	-195	V
white level	-350	V
Peak r.f. grid voltage	375	V
Anode current:		
synchronising level	3.45	A
pedestal level	2.42	A
Screen current (pedestal level)	148	mA
Grid current (approx):		
synchronising level	175	mA
pedestal level	95	mA
Driving power (approx, see note 4):		
synchronising level (see note 5)	800	W
pedestal level	425	W
Output power (approx):		
synchronising level	12	kW
pedestal level	6.8	kW

LINEAR R.F. POWER AMPLIFIER
(Single-sideband Suppressed-carrier Service)

MAXIMUM RATINGS (Absolute values) (up to 220MHz)

Anode voltage	7.5	kV max
Screen voltage	2.0	kV max
Maximum-signal anode current	2.8	A max
Maximum-signal grid current	0.6	A max
Maximum-signal anode input power	20	kW max
Maximum-signal screen input power	400	W max
Anode dissipation	12	kW max

TYPICAL OPERATION (at 60MHz)
(Class AB₂ single-tone operation)

Anode voltage	7.0	kV
Screen voltage	1.2	kV
Grid voltage (see note 8)	-125	V
Zero-signal anode current	0.2	A
Zero-signal screen current	0	A
Effective r.f. load resistance	1350.	Ω
Maximum-signal anode current	2.75	A
Maximum-signal screen current	260	mA
Maximum-signal grid current	80	mA
Maximum-signal driving power (approx)	25	W
Maximum-signal output power (approx)	12	kW

ANODE-MODULATED R.F. POWER AMPLIFIER

(Class C Telephony, carrier conditions per valve for use with a maximum modulation factor of 1.0)

MAXIMUM RATINGS (Absolute values) (up to 220MHz)

Anode voltage	5.5	kV max
Screen voltage	2.0	kV max
Grid voltage	-1.0	kV max
Anode current	2.0	A max
Grid current	600	mA max
Anode input power	10	kW max
Screen input power	270	W max
Anode dissipation	8.0	kW max

TYPICAL OPERATION IN GRID-DRIVE CIRCUIT

(at frequencies up to 60MHz)

Anode voltage	4.8	kV
Screen voltage (modulated 100%, see note 9)	800	V
Grid voltage (see note 10)	-300	V
Peak r.f. grid voltage	550	V
Anode current	1.8	A
Screen current	160	mA
Grid current (approx)	180	mA
Driving power (approx. See notes 4 and 11)	125	W
Output power (approx)	6.0	kW

R.F. POWER AMPLIFIER AND OSCILLATOR

(Class C Telegraphy, key-down conditions per valve, see Note 12)

AND R.F. POWER AMPLIFIER (Class C, F.M. Telephony)

MAXIMUM RATINGS (Absolute values) (up to 220MHz)

Anode voltage	7.5	kV max
Screen voltage	2.0	kV max
Grid voltage	-1.0	kV max
Anode current	3.0	A max
Grid current	600	mA max
Anode input power	20	kW max
Screen input power	400	W max
Anode dissipation	12	kW max

TYPICAL OPERATION IN GRID-DRIVE CIRCUIT

Frequency	up to 60	216	MHz
Anode voltage	6.6	7.0	kV
Screen voltage (see note 13)	1.2	1.2	kV
Grid voltage (see note 14)	-310	-310	V
Peak r.f. grid voltage	560	560	V
Anode current	2.75	2.75	A
Screen current	300	300	mA
Grid current (approx)	140	140	mA
Driving power (approx) (see note 4)	*95	†750	W
Output power (approx)	12	10	kW

* See note 15

† See note 16

NOTES

1. The valve must be operated at the stated filament voltage. Fluctuations must not exceed $\pm 5\%$.
2. Measured with external flat metal shield 12 inches (305mm) square having a centre hole 4.312 inches (109.5mm) diameter located in the plane of the screen grid terminal, perpendicular to the valve axis, and connected to the screen grid.
3. Computed between half-power points and based on valve output capacitance only.
4. The driver stage is required to supply valve losses and r.f. circuit losses. The driver stage should be designed to provide an excess of power above the indicated value to take care of variations in line voltage, components, initial valve characteristics, and valve characteristics during life.
5. This value includes 700W of r.f. circuit loss at 216MHz.
6. The driver stage is required to supply the r.f. power added to the anode circuit in addition to the losses indicated under Note 4.
7. This value includes 470W of r.f. circuit loss at 216MHz and 1030W added to anode circuit.
8. Adjusted to give the indicated zero-signal anode current.
9. Obtained preferably from a separate source.
10. Obtained preferably from a combination of 365 ohms control grid resistor and $-170V$ fixed bias.
11. This value includes 25W of r.f. circuit loss.
12. Modulation essentially negative may be used if the positive peak of the a.f. envelope does not exceed 115% of the carrier conditions.
13. Obtained preferably from a separate source, or from the anode supply voltage with a voltage divider, or through a series resistor. A series screen resistor should not be used if the tube or a preceding stage is keyed. In this case, the regulation of the source should be sufficient to prevent the screen voltage from rising above 2000V under key-up conditions and additional fixed grid bias must be provided to limit the anode current.
14. Obtained from fixed supply, by grid resistor, by cathode resistor, or by combination methods.
15. This value includes 20W of r.f. circuit loss.
16. This value includes 675W of r.f. circuit loss.

TYPICAL ANODE CHARACTERISTICS

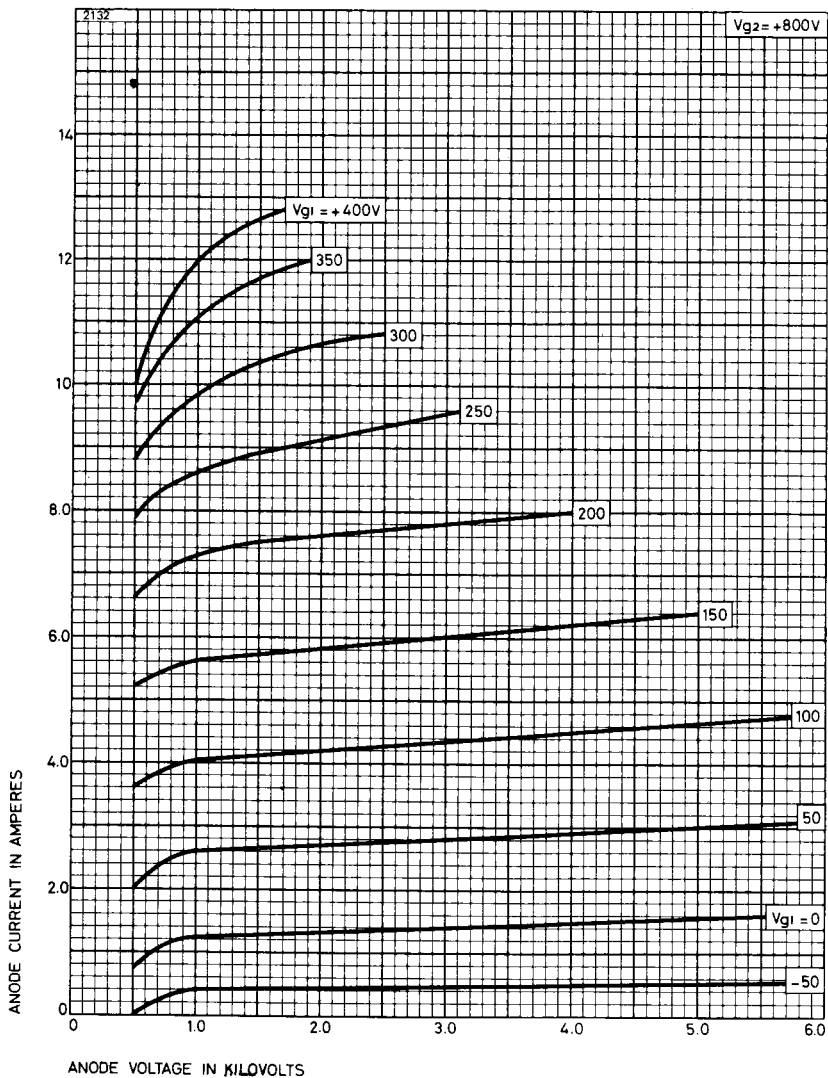

TYPICAL GRID AND SCREEN CHARACTERISTICS

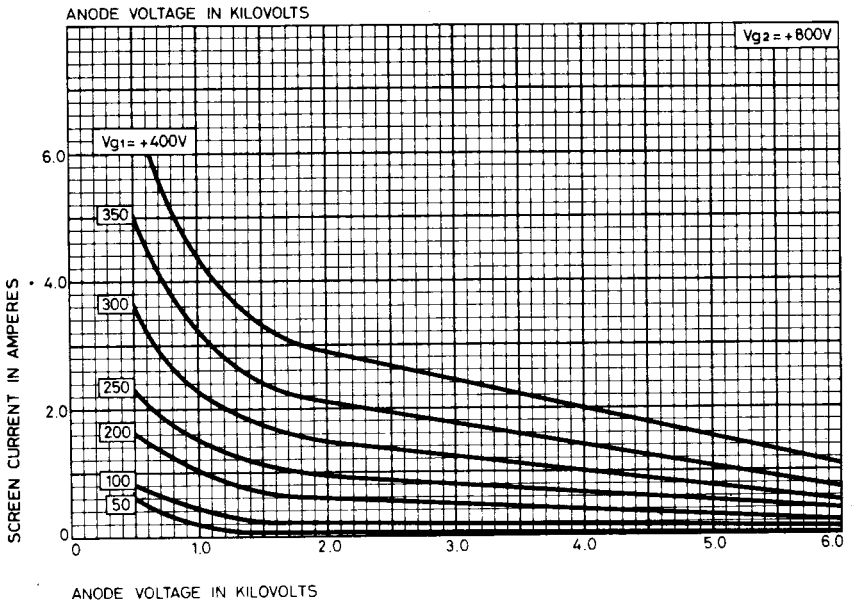
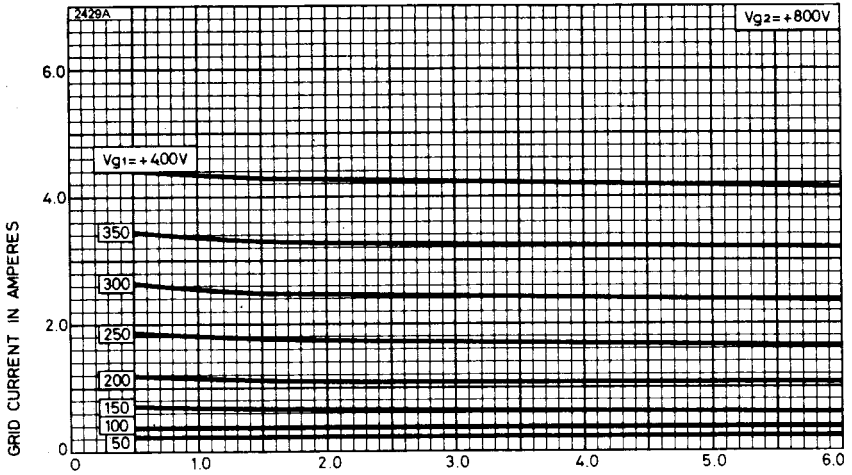

TYPICAL CONSTANT CURRENT CHARACTERISTICS

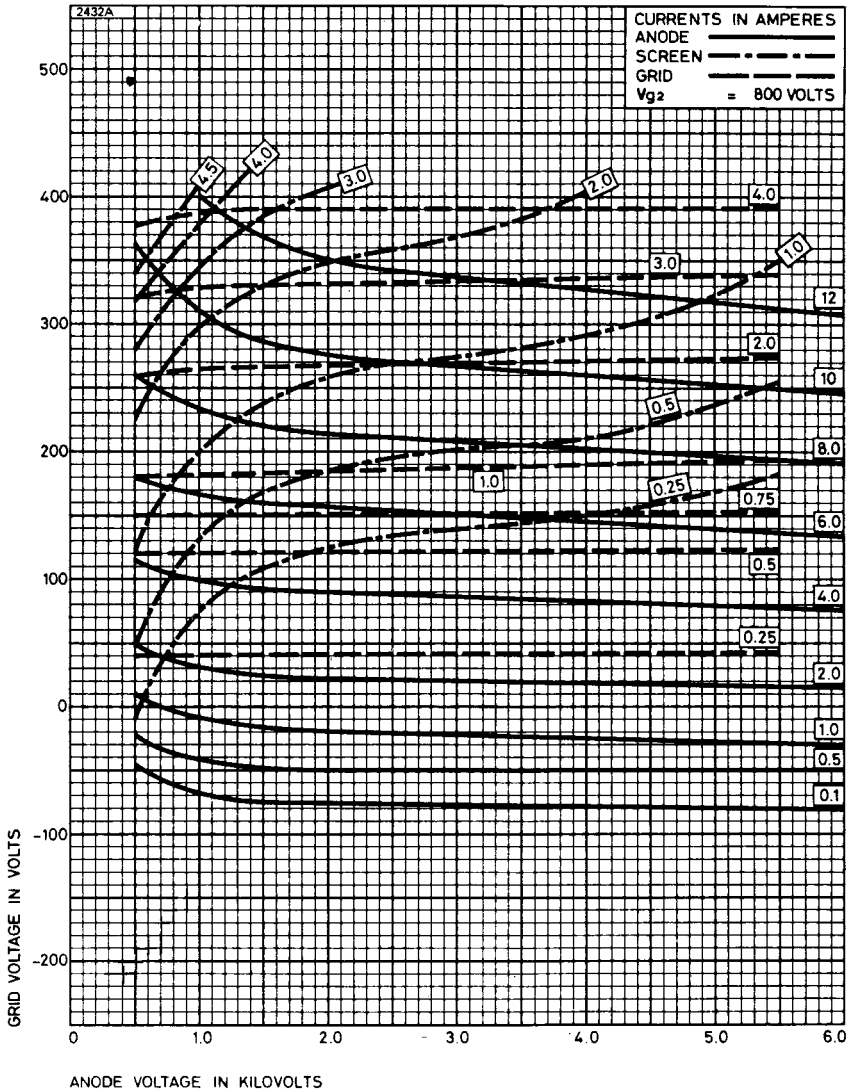

TYPICAL ANODE CHARACTERISTICS

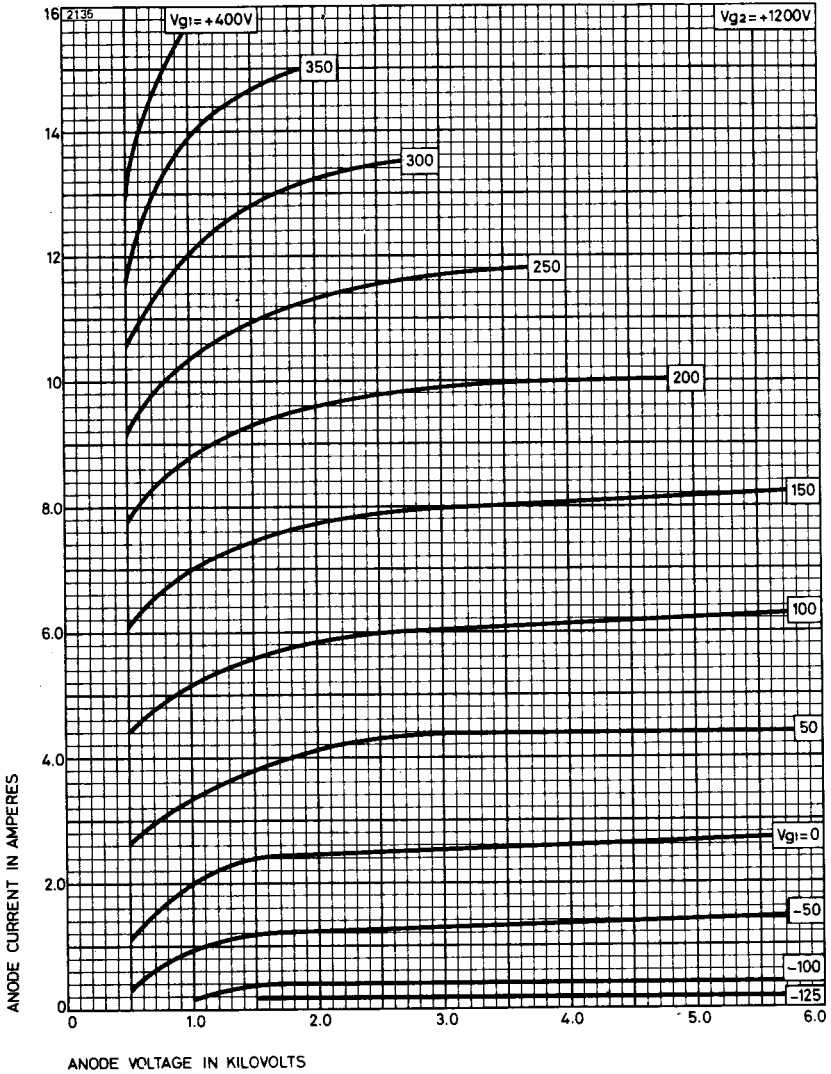

TYPICAL GRID AND SCREEN CHARACTERISTICS

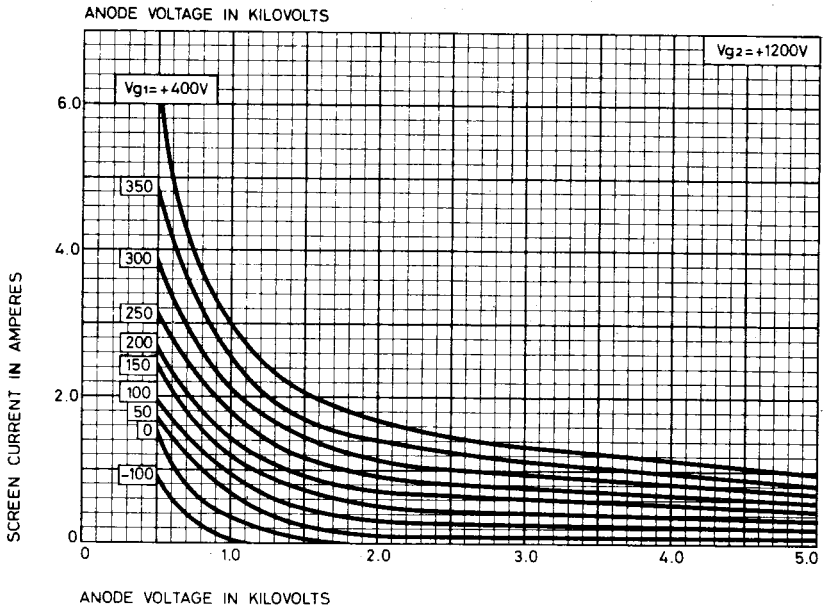
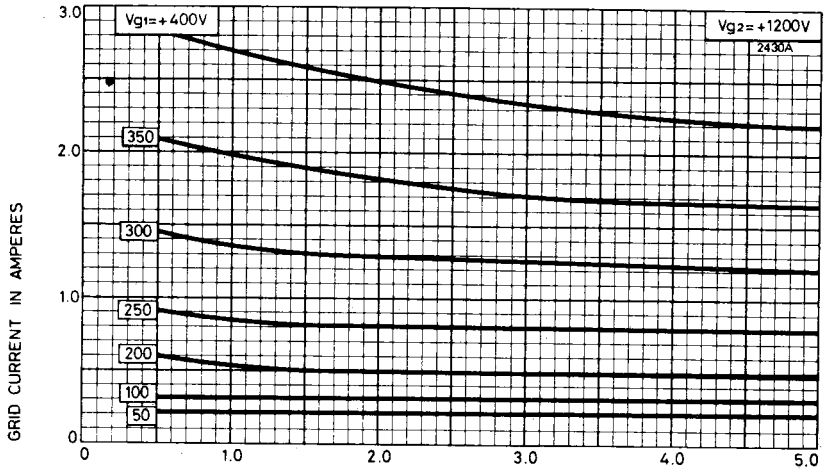

TYPICAL CONSTANT CURRENT CHARACTERISTICS

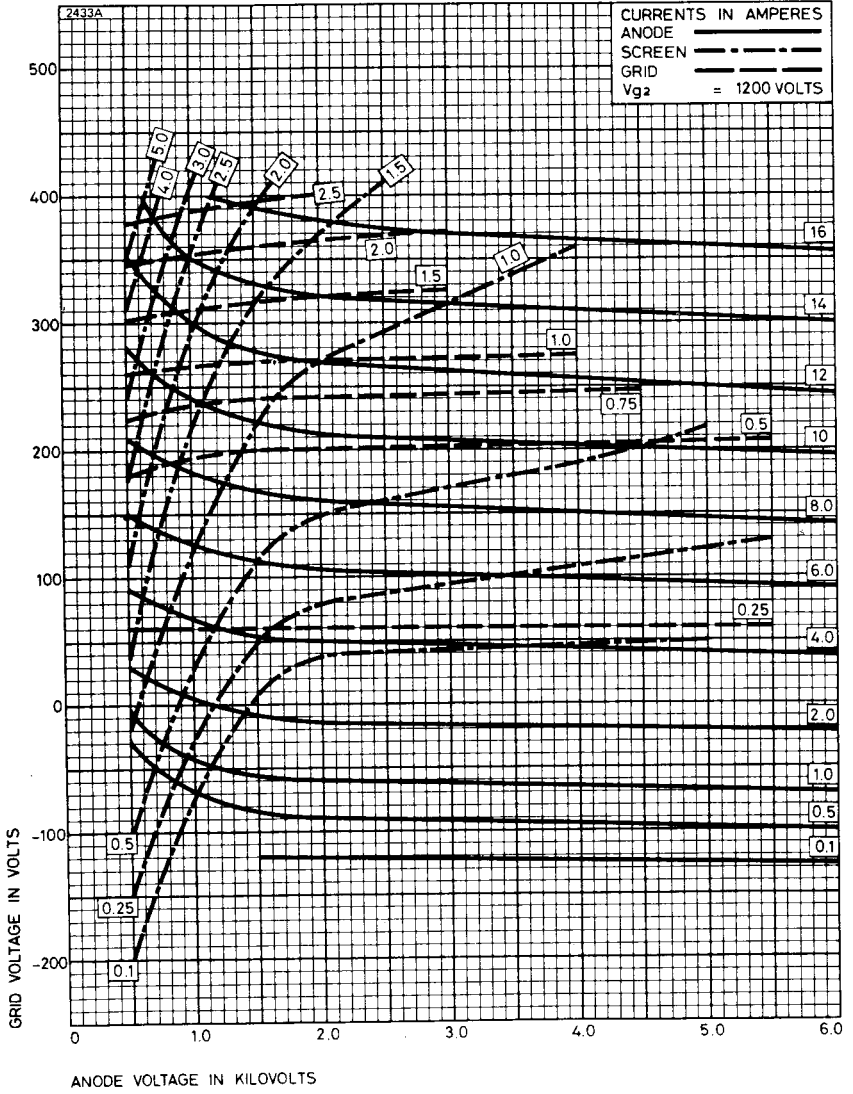

TYPICAL ANODE CHARACTERISTICS

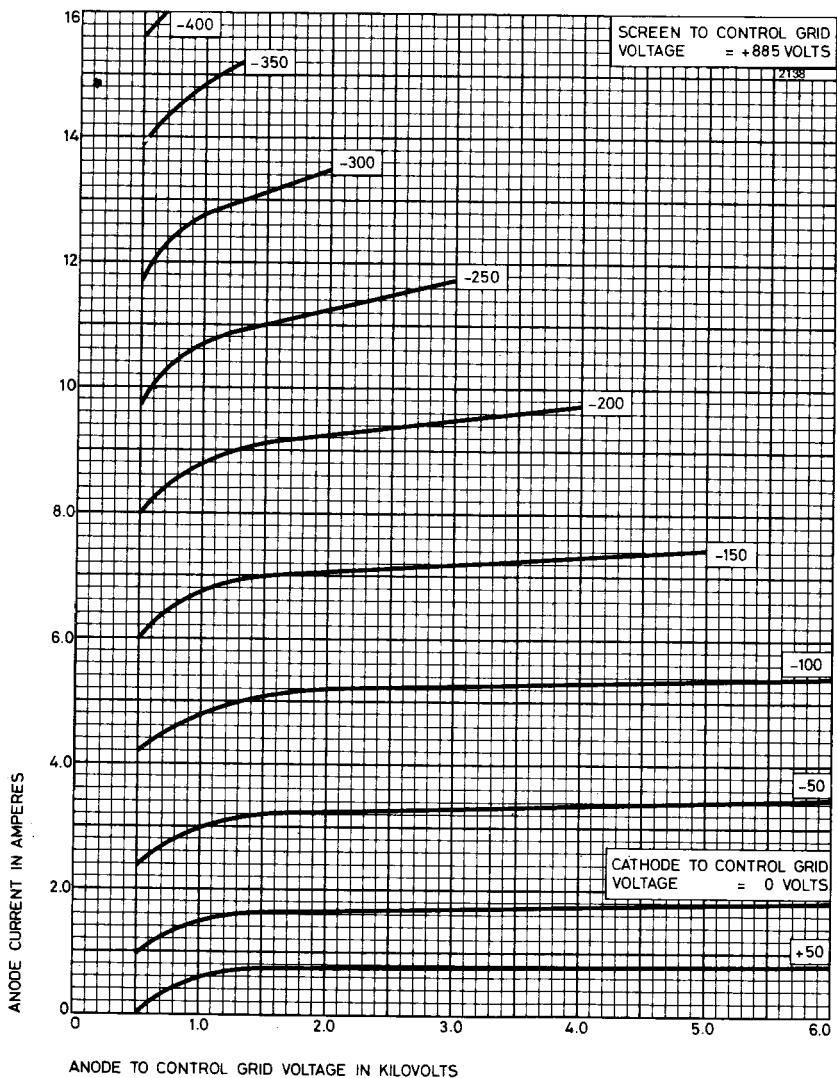

TYPICAL GRID AND SCREEN CHARACTERISTICS

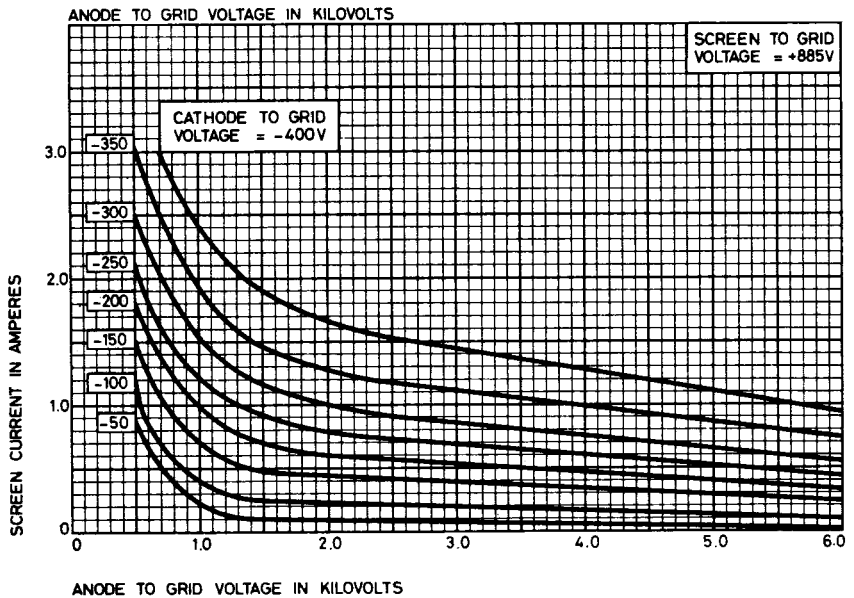
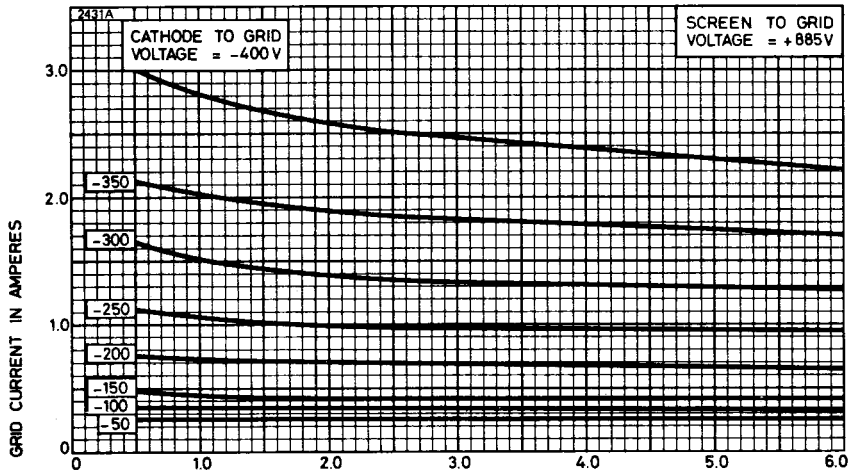

TYPICAL CONSTANT CURRENT CHARACTERISTICS

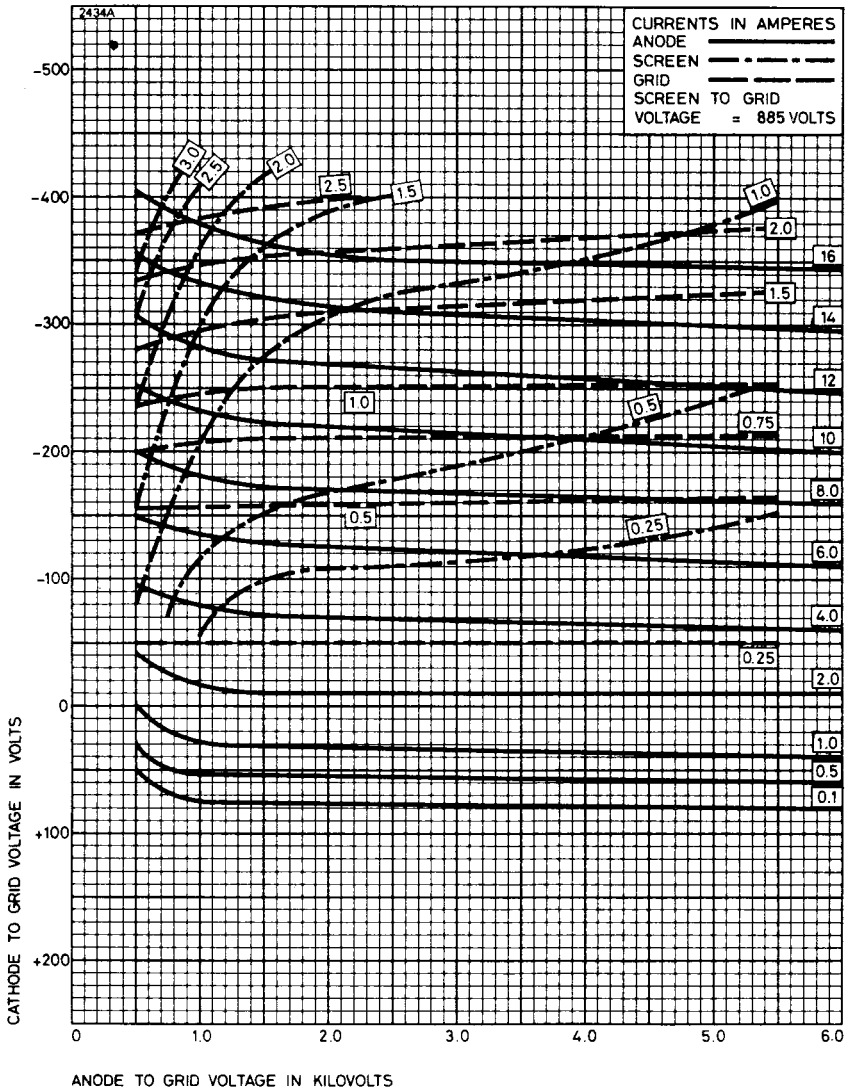

AIR COOLING REQUIREMENTS

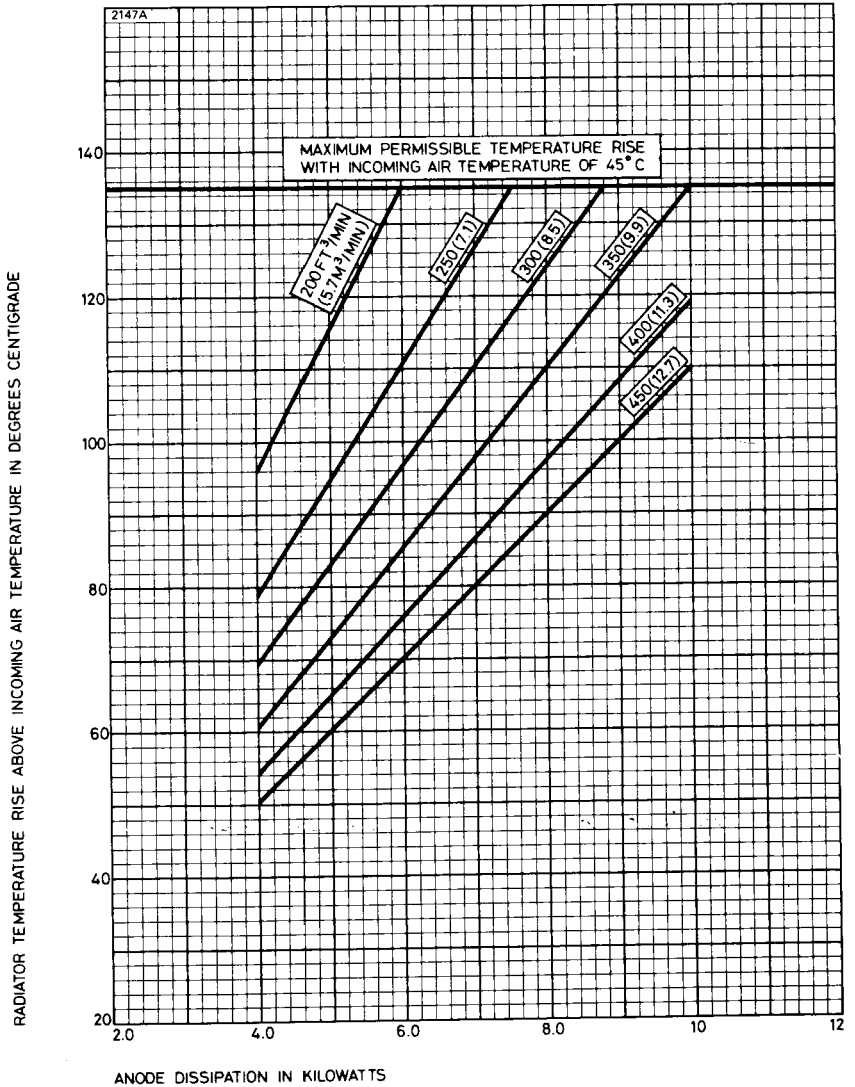

TYPICAL AIR FLOW CHARACTERISTIC

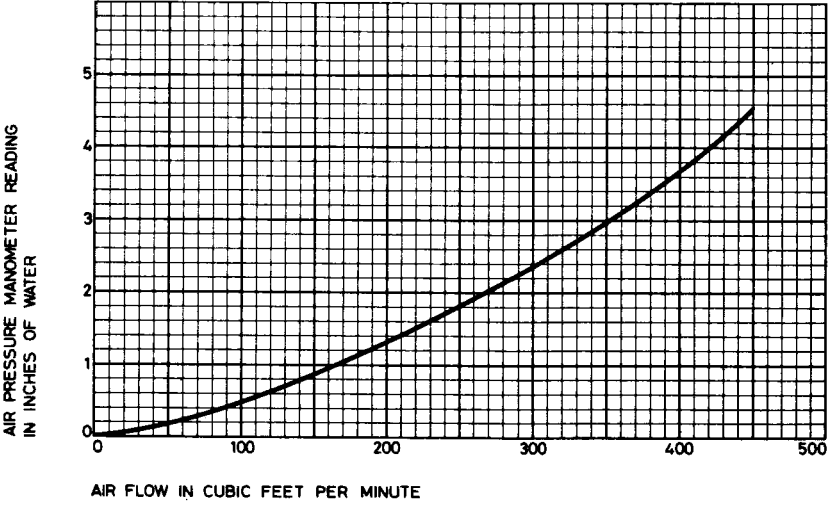
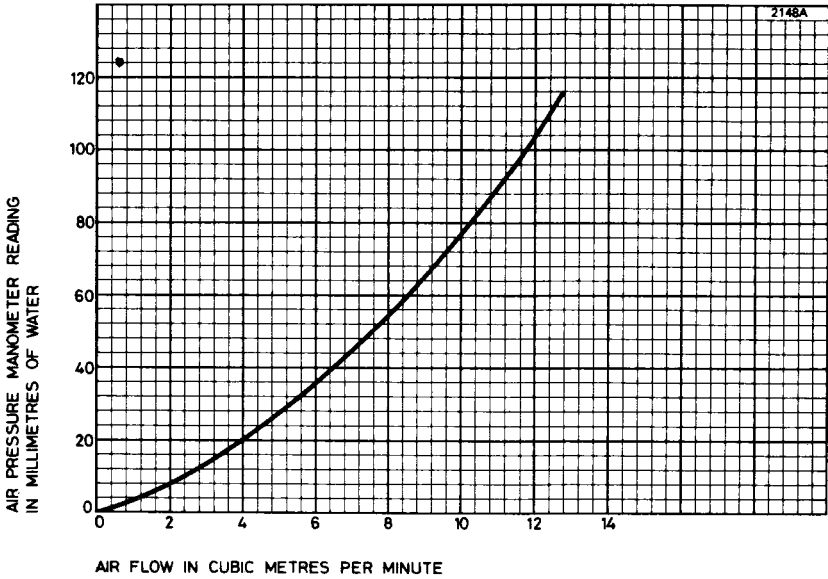

OUTLINE

3142

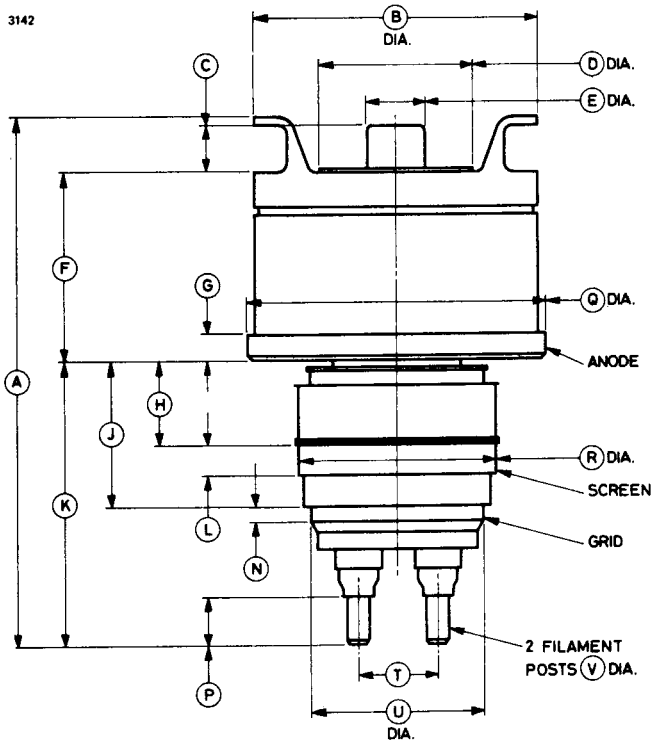

Ref	Inches	Millimetres	Ref	Inches	Millimetres
A	11.500 max	292.1 max	K	5.990 ± 0.120	152.1 ± 3.0
B	6.000 ± 0.100	152.4 ± 2.5	L	0.500 min	12.70 min
C	1.165 max	29.59 max	N	0.350 min	8.89 min
D	3.375 max	85.73 max	P	0.812 min	20.62 min
E	1.187	30.15	Q	6.360 ± 0.020	161.54 ± 0.51
F	4.100 max	104.1 max	R	4.246 ± 0.020	107.85 ± 0.51
G	0.500 ± 0.030	12.70 ± 0.76	T	1.710 ± 0.040	43.43 ± 1.02
H	1.820 ± 0.040	46.23 ± 1.02	U	3.686 ± 0.024	93.62 ± 0.61
J	3.120 ± 0.060	79.25 ± 1.52	V	0.437 ± 0.007	11.10 ± 0.18

Millimetre dimensions have been derived from inches.



CR176

R.F. POWER TETRODE

Service Type CV2324

The data should be read in conjunction with the Power Tetrode Preamble.

ABRIDGED DATA

Forced-air cooled transmitting tetrode.

Anode dissipation	3.5	kW max
Anode voltage	7.5	kV max
Frequency for full ratings	30	MHz max

GENERAL

Electrical

Filament		thoriated tungsten
Filament voltage (see note 1)	5.0	V
Filament current	64	A
Surge filament current (peak) (see note 2)	160	A max
Filament cold resistance	4.5	mΩ
Peak usable cathode current	10	A
Grid-screen amplification factor		
($V_a = 3.0\text{kV}$, $V_{g2} = 1.5\text{kV}$, $I_a = 1.0\text{A}$)	4.4	
Mutual conductance		
($V_a = 3.0\text{kV}$, $V_{g2} = 1.5\text{kV}$, $I_a = 1.0\text{A}$)	8.25	mA/V
Inter-electrode capacitances:		
grid to anode	0.4	pF
input	42	pF
output	14	pF

Mechanical

Overall length	12.640 inches (321.1mm) max
Overall diameter	7.250 inches (184.2mm) max
Net weight	14 pounds (6.4kg) approx
Mounting position	vertical, filament end up

COOLING

The CR176 air cooling requirements are shown on pages 6 and 7. The required air flow should be delivered through the radiator before and during the application of any voltages. Power and air supplies may be removed simultaneously.

The filament and grid seals do not normally require forced-air cooling, but their temperatures must not exceed 140°C.

MAXIMUM RATINGS (Absolute values)

Anode voltage	7.5	kV max
Screen voltage	1.5	kV max
Anode dissipation	3.5	kW max
Screen dissipation	200	W max
Grid dissipation	25	W max
Operating frequency (for full ratings)	30	MHz max

RANGE OF CHARACTERISTICS FOR EQUIPMENT DESIGN



	Min	Max	
Filament current at filament voltage 5.0V	59	71	A
Grid-screen amplification factor ($V_a = 3.0kV, V_{g2} = 1.5kV, I_a = 1.0A$)	3.7	5.1	
Mutual conductance ($V_a = 3.0kV, V_{g2} = 1.5kV, I_a = 1.0A$)	7.5	9.0	mA/V
Screen current ($V_a = 4.0kV, V_{g2} = 1.5kV, I_a = 1.0A$)	-	30	mA
Grid voltage (negative value) ($V_a = 4.0kV, V_{g2} = 1.5kV, I_a = 1.0A$)	170	260	V
Grid voltage (negative value) ($V_a = 4.0kV, V_{g2} = 1.5kV, I_a = 50mA$)	-	500	V

NOTES

1. The valve must be operated at the stated filament voltage. Fluctuation in filament voltage must not exceed $\pm 5\%$.
2. The filament current must not exceed 160A, even momentarily, at any time.

TYPICAL ANODE CHARACTERISTICS

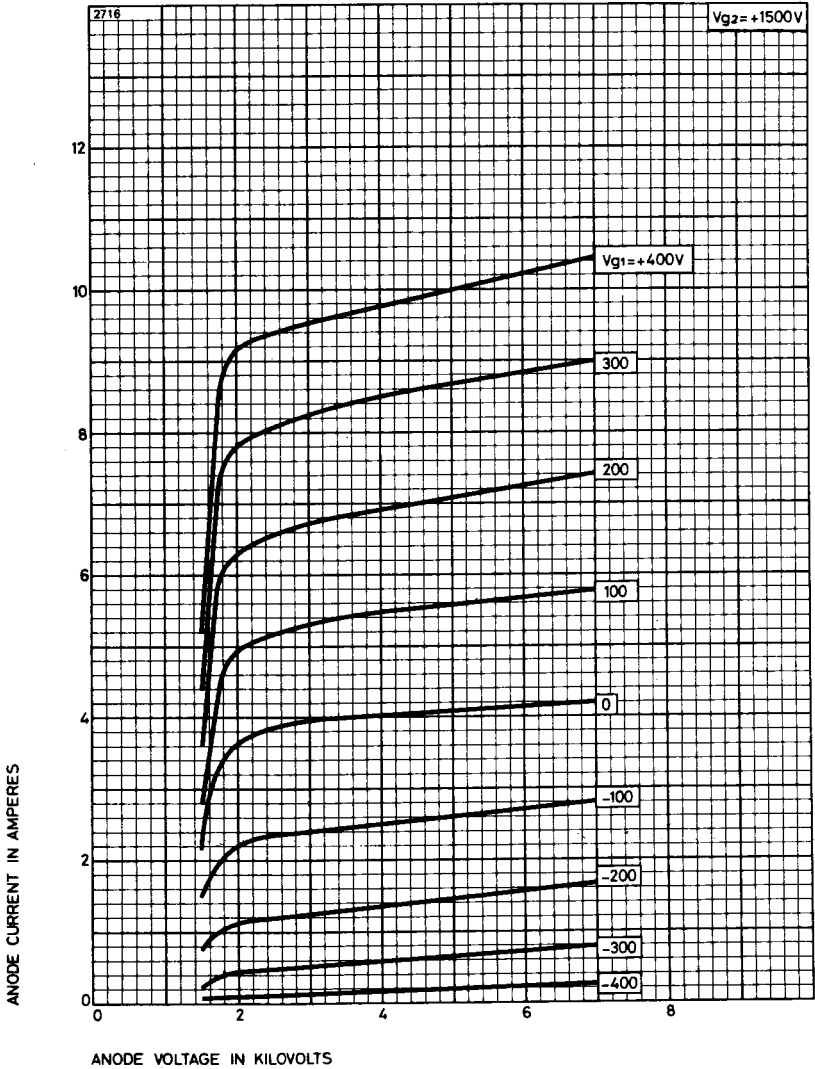

TYPICAL SCREEN CHARACTERISTICS

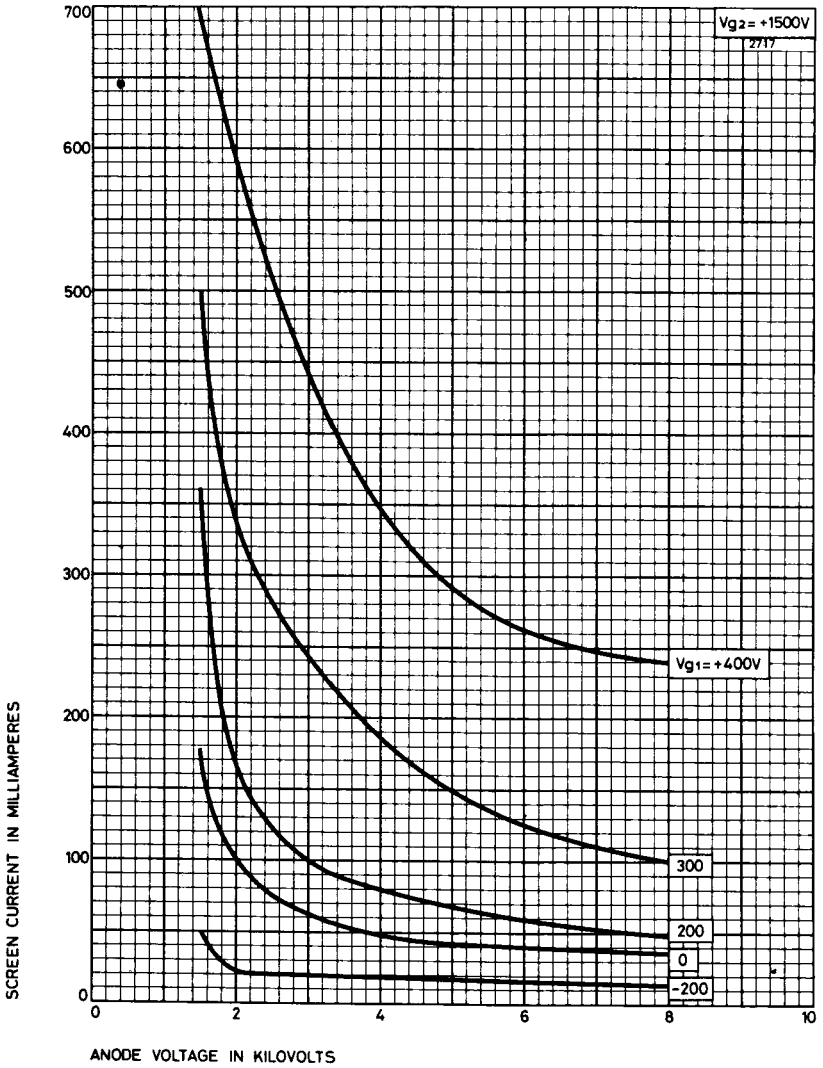

TYPICAL GRID CHARACTERISTICS

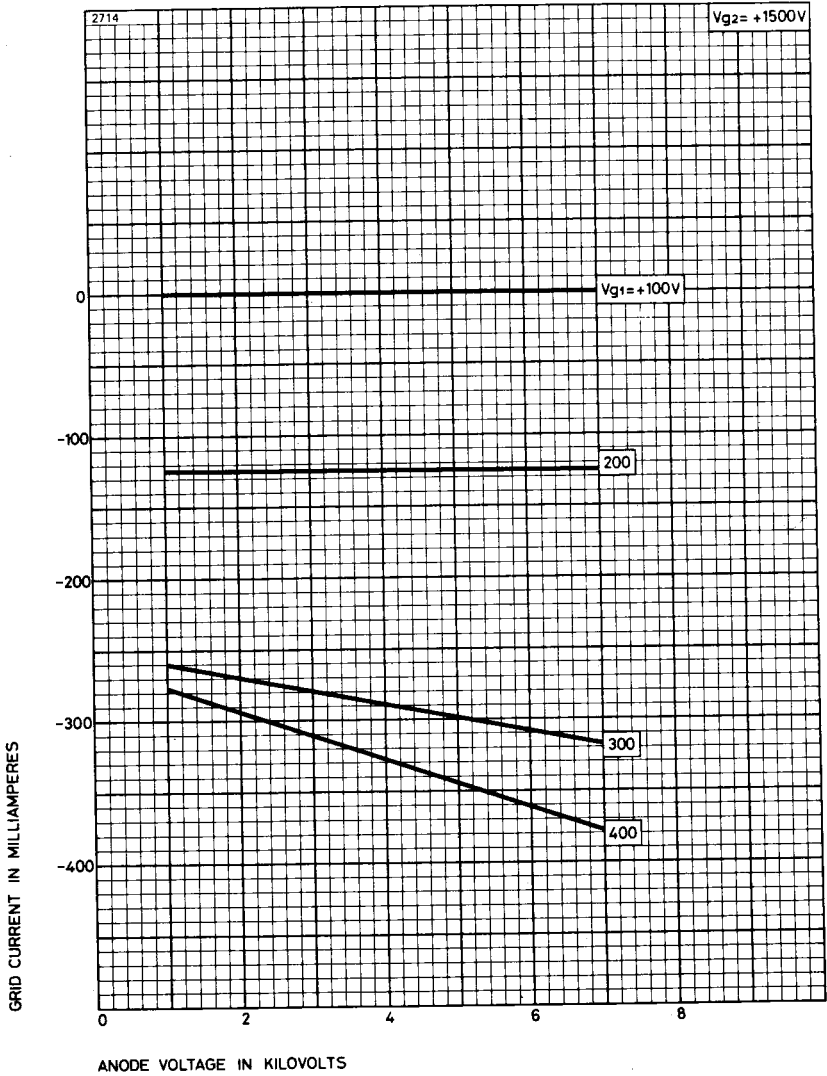

AIR COOLING REQUIREMENTS

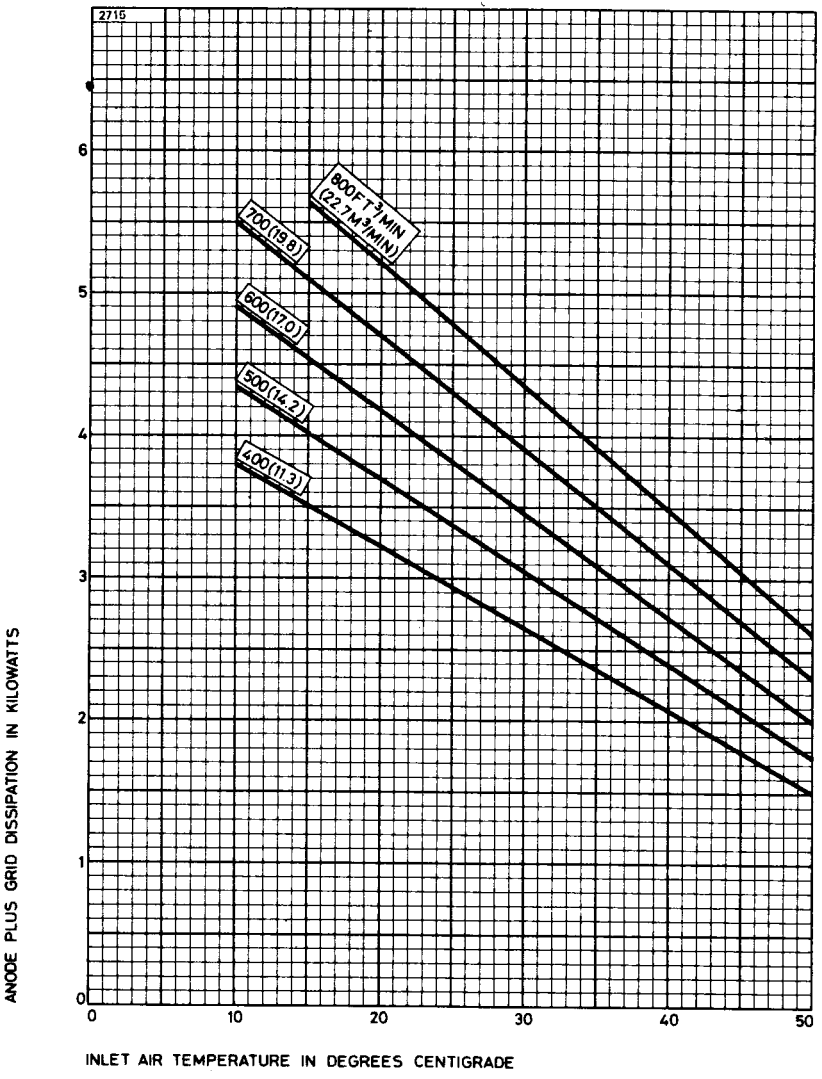

TYPICAL AIR FLOW CHARACTERISTIC

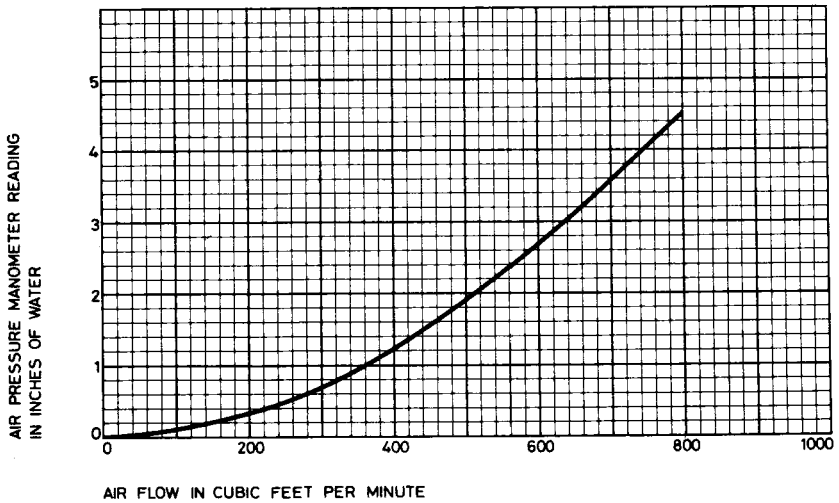
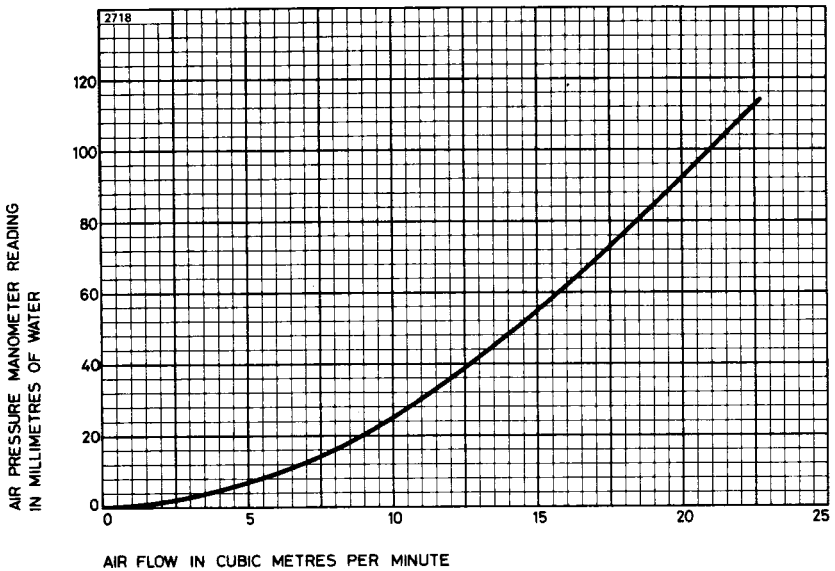

OUTLINE (All dimensions without limits are nominal)

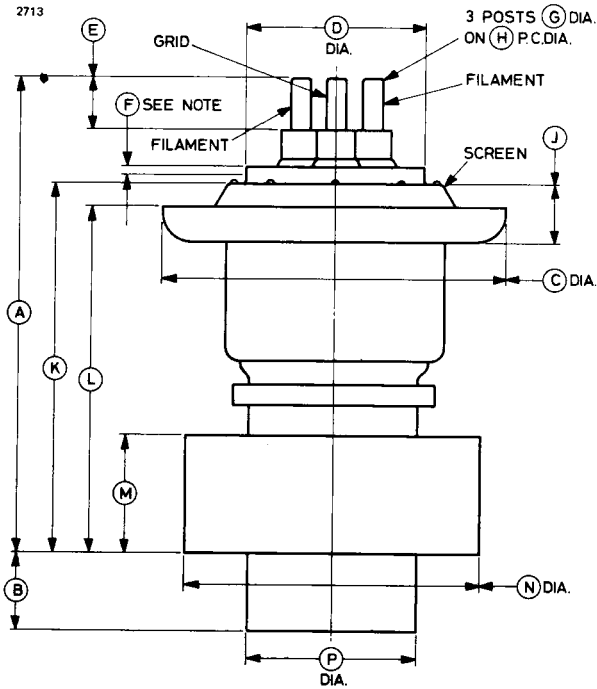

Note Contact length.

Ref	Inches	Millimetres	Ref	Inches	Millimetres
A	10.750 max	273.1 max	H	1.500	38.10
B	1.890 max	48.01 max	J	1.250 ± 0.015	31.75 ± 0.38
C	7.250 max	184.2 max	K	8.150 max	207.0 max
D	3.750 ± 0.010	95.25 ± 0.25	L	7.360 ± 0.080	186.9 ± 2.0
E	1.125	28.58	M	2.578 ± 0.050	65.48 ± 1.27
F	0.160 min	4.06 min	N	6.250 ± 0.125	158.8 ± 3.2
G	0.437	11.10	P	3.580 max	90.93 max

Millimetre dimensions have been derived from inches.

English Electric Valve Company Limited

Chelmsford, Essex, England

CR176

Page 8

Printed in England



CR192A

V.H.F. POWER TETRODE

American equivalent 6166A*

Service Type CV8244

The data should be read in conjunction with the Power Tetrode Preamble.

ABRIDGED DATA

Forced-air cooled tetrode with coaxial metal-ceramic envelope, for television and other applications at frequencies up to 220MHz.

Anode dissipation	10	kW max
Anode voltage	6.9	kV max
Frequency for full ratings:		
class C telegraphy or f.m. telephony	60	MHz max
class B or class C television service	216	MHz max
Output power:		
television service (synchronising level)	12	kW
class C telegraphy or f.m. telephony (216MHz)	9.0	kW



GENERAL

Electrical

Filament	thoriated tungsten
Filament voltage (see note 1)	5.0 V
Filament current	175 A
Surge filament current (peak) (see note 2)	400 A max
Filament cold resistance	3.8 mΩ
Peak usable cathode current	20 A
Grid-screen amplification factor ($V_a = 2.0kV, V_{g2} = 1.0kV, I_a = 2.0A$)	10
Mutual conductance ($V_a = 2.0kV, V_{g2} = 1.0kV, I_a = 2.0A$)	25 mA/V

Continued on page 2

* CR192A is a direct replacement for types 6166 and 6166A, except that the filament posts are larger in diameter. Suitable filament adaptors are available to facilitate replacement of 6166 or 6166A in existing equipments (see page 20).

Electrical (continued)

Inter-electrode capacitances:

grid to anode (see note 3)	0.6	pF max
grid to filament	44	pF
anode to filament (see note 3)	0.08	pF max
grid to screen grid	60	pF
screen grid to anode	21	pF

Mechanical

Overall length	11.625 inches (295.3mm) max
Overall diameter	6.410 inches (162.8mm) max
Net weight	17 pounds (7.8kg) approx
Mounting position	vertical, either way up

COOLING

The required quantity of air through the radiator for cooling the anode is indicated on the graphs (pages 17 and 18) and should be delivered by a blower through the radiator before and during the application of any voltages. It should enter at the envelope end and some of the flow should be used to cool the screen-grid seal.

In addition, a flow of about 50ft³/min (1.42m³/min) should be directed at the filament and grid terminals.

The temperature of anode, screen, grid and filament seals must not exceed 180°C.

Power and air supplies may be removed simultaneously.

R.F. POWER AMPLIFIER

(Class B Television Service, U.S.A. System)

(Synchronising-level conditions per valve unless otherwise specified. Voltages are referred to cathode unless otherwise specified)

MAXIMUM RATINGS (Absolute values) (Frequency 54 to 216MHz)

Anode voltage	6.0	kV max
Screen voltage	2.0	kV max
Anode current	4.0	A max
Anode input power	22	kW max
Screen input power	400	W max
Anode dissipation	10	kW max
Grid dissipation	300	W max

TYPICAL OPERATION IN GRID-DRIVE CIRCUIT
(at 216MHz and bandwidth 8.5MHz — see note 4)

Anode voltage	5.8	kV
Screen voltage	1.2	kV
Grid voltage	-130	V
Peak r.f. grid voltage:		
synchronising level	375	V
pedestal level	290	V
Anode current:		
synchronising level	3.45	A
pedestal level	2.60	A
Screen current (pedestal level)	207	mA
Grid current (approx):		
synchronising level	350	mA
pedestal level	170	mA
Driving power (approx, see note 5):		
synchronising level (see note 6)	800	W
pedestal level	450	W
Output power (approx):		
synchronising level	12	kW
pedestal level	6.8	kW

TYPICAL OPERATION IN CATHODE-DRIVE CIRCUIT
(at 216MHz and bandwidth 8.5MHz — see note 4)

Anode voltage	5.8	kV
Screen voltage	800	V
Grid voltage	-85	V
Peak r.f. grid voltage:		
synchronising level	330	V
pedestal level	260	V
Anode current:		
synchronising level	3.45	A
pedestal level	2.60	A
Screen current (pedestal level)	152	mA
Grid current (approx):		
synchronising level	405	mA
pedestal level	220	mA
Driving power (approx, see note 7):		
synchronising level (see note 8)	1.3	kW
pedestal level	700	W
Output power (approx):		
synchronising level	12	kW
pedestal level	6.8	kW

GRID-MODULATED R.F. POWER AMPLIFIER

(Class C Television Service, U.S.A. System)

(Synchronising-level conditions per valve unless otherwise specified)

MAXIMUM RATINGS (Absolute Values) (frequency 54 to 216MHz)

Anode voltage	6.0	kV max
Screen voltage	2.0	kV max
Grid voltage (white level)	-1.0	kV max
Anode current	4.0	A max
Anode input power	22	kW max
Screen input power	400	W max
Anode dissipation	10	kW max
Grid dissipation	300	W max

TYPICAL OPERATION IN GRID-DRIVE CIRCUIT

(at 216MHz and bandwidth 8.5MHz, See Note 4)

Anode voltage	5.8	kV
Screen voltage	1.2	kV
Grid voltage:		
synchronising level	-130	V
pedestal level	-195	V
white level	-350	V
Peak r.f. grid voltage	375	V
Anode current:		
synchronising level	3.45	A
pedestal level	2.42	A
Screen current (pedestal level)	148	mA
Grid current (approx):		
synchronising level	350	mA
pedestal level	190	mA
Driving power (approx, see note 5):		
synchronising level (see note 6)	800	W
pedestal level	425	W
Output power (approx):		
synchronising level	12	kW
pedestal level	6.8	kW

ANODE-MODULATED R.F. POWER AMPLIFIER

(Class C Telephony, carrier conditions per valve for use with a maximum modulation factor of 1.0)

MAXIMUM RATINGS (Absolute Values. See Note 9)

Anode voltage	5.0	kV max
Screen voltage	2.0	kV max
Grid voltage	-1.0	kV max
Anode current	2.0	A max
Grid current	600	mA max
Anode input power	10	kW max
Screen input power	270	W max
Anode dissipation	6.6	kW max

TYPICAL OPERATION IN GRID-DRIVE CIRCUIT

(at frequencies up to 60MHz)

Anode voltage	4.7	kV
Screen voltage (modulated 100%, see note 10)	800	V
Grid voltage (see note 11)	-280	V
Peak r.f. grid voltage	485	V
Anode current	1.56	A
Screen current	217	mA
Grid current (approx)	300	mA
Driving power (approx. See note 12)	180	W
Output power (approx)	5.5	kW

R.F. POWER AMPLIFIER AND OSCILLATOR

(Class C Telegraphy, key-down conditions per valve, see Note 19)

AND R.F. POWER AMPLIFIER (Class C, F.M. Telephony)

MAXIMUM RATINGS (Absolute Values. See Note 9)

Anode voltage	6.9	kV max
Screen voltage	2.0	kV max
Grid voltage	-1.0	kV max
Anode current	2.75	A max
Grid current	600	mA max
Anode input power	18	kW max
Screen input power	400	W max
Anode dissipation	10	kW max

TYPICAL OPERATION IN GRID-DRIVE CIRCUIT

Frequency	up to 60	216	216	MHz
Anode voltage	6.4	5.8	5.8	kV
Screen voltage (see note 13)	1.2	1.2	1.2	kV
Grid voltage (see note 14)	-310	-130	-175	V
Peak r.f. grid voltage	560	230	370	V
Anode current	2.75	1.8	2.6	A
Screen current	300	100	267	mA
Grid current (approx)	280	100	222	mA
Driving power (approx) (see note 5)	75	*300	†750	W
Output power (approx)	11.6	6.0	9.0	kW

* See note 15

† See note 16

MAXIMUM PERMISSIBLE ANODE VOLTAGES AND INPUTS (expressed as a percentage of maximum values quoted)

	Frequency	
	60MHz	220MHz
Class C telephony, anode modulated	100%	90%
Class C telegraphy and f.m. telephony		
Class B television service	Full ratings	
Class C television service	54 to 216MHz	

NOTES

1. The valve must be operated at the stated filament voltage. Fluctuations must not exceed $\pm 5\%$.
2. The filament current must not exceed 400A, even momentarily, at any time.
3. Measured with external flat metal shield 12 inches (305mm) square having a centre hole 4.312 inches (109.5mm) diameter located in the plane of the screen grid terminal, perpendicular to the valve axis, and connected to the screen grid.
4. Computed between half-power points and based on valve output capacitance only.
5. The driver stage is required to supply valve losses and r.f. circuit losses. The driver stage should be designed to provide an excess of power

above the indicated value to take care of variations in line voltage, components, initial valve characteristics, and valve characteristics during life.

6. This value includes 700W of r.f. circuit loss at 216MHz.
7. The driver stage is required to supply the r.f. power added to the anode circuit in addition to the losses indicated under Note 5.
8. This value includes 300W of r.f. circuit loss at 216MHz and 900W added to anode circuit.
9. These ratings apply for operation up to 60MHz; for ratings at higher frequencies, see table on page 6.
10. Obtained preferably from a separate source.
11. Obtained preferably from a combination of 365 ohms control grid resistor and $-170V$ fixed bias.
12. This value includes 50W of r.f. circuit loss at 30MHz.
13. Obtained preferably from a separate source, or from the anode supply voltage with a voltage divider, or through a series resistor. A series screen resistor should not be used if the tube or a preceding stage is keyed. In this case, the regulation of the source should be sufficient to prevent the screen voltage from rising above 2000V under key-up conditions and additional fixed grid bias must be provided to limit the anode current.
14. Obtained from fixed supply, by grid resistor, by cathode resistor, or by combination methods.
15. This value includes 270W of r.f. circuit loss.
16. This value includes 675W of r.f. circuit loss.
17. In Class B and Class C television circuits, the valve should be supplied with its grid bias voltage from a source of good regulation — not from a grid resistor. In anode-modulated Class C operation, the grid bias may be obtained from a grid resistor or part from a grid resistor and the balance from either a cathode bias resistor or a fixed voltage. In Class C telegraphy or Class C f.m. telephony operation, the bias may be obtained by any convenient method.
18. With Class B and Class C television circuits, or with Class C f.m. operation the screen should be supplied from a source having good regulation. With anode-modulated Class C operation the screen voltage may preferably be obtained from a separate source and the screen grid should be modulated so as to keep the ratio of screen to anode voltages constant. With Class C telegraphy any convenient method may be used.
19. Modulation essentially negative may be used if the positive peak of the a.f. envelope does not exceed 115% of the carrier conditions.



TYPICAL ANODE CHARACTERISTICS

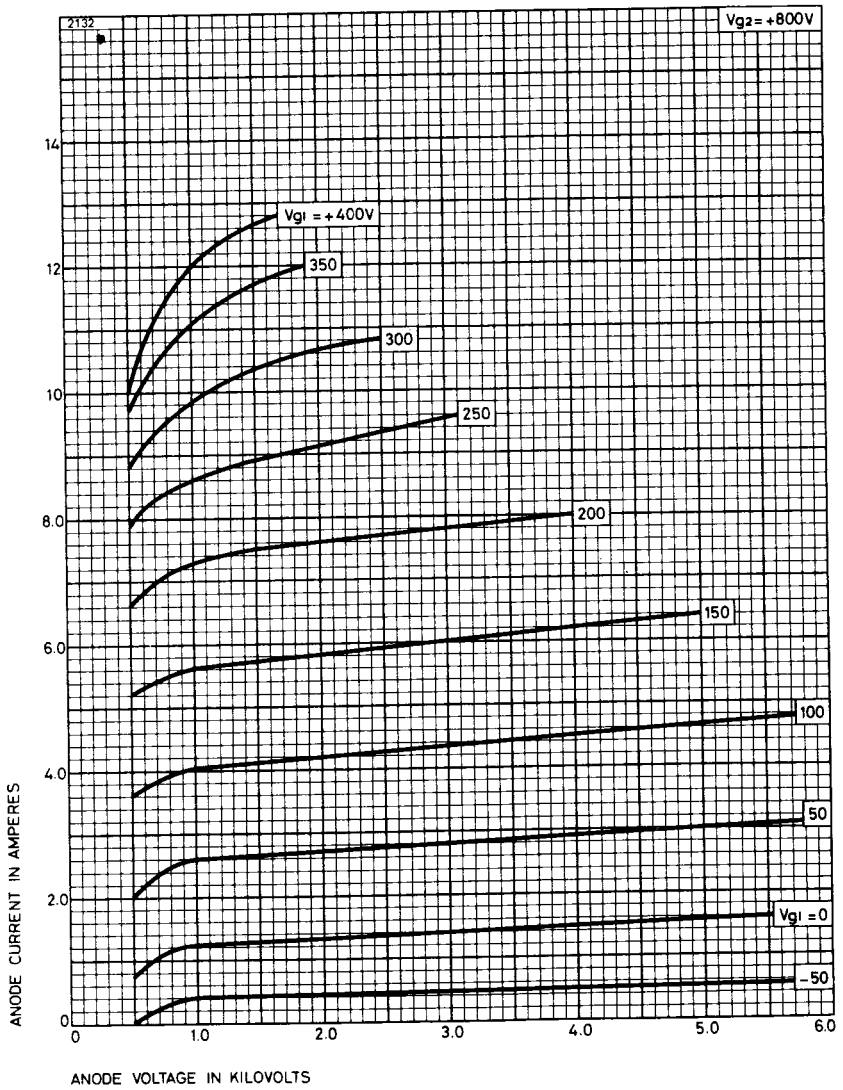

TYPICAL GRID AND SCREEN CHARACTERISTICS

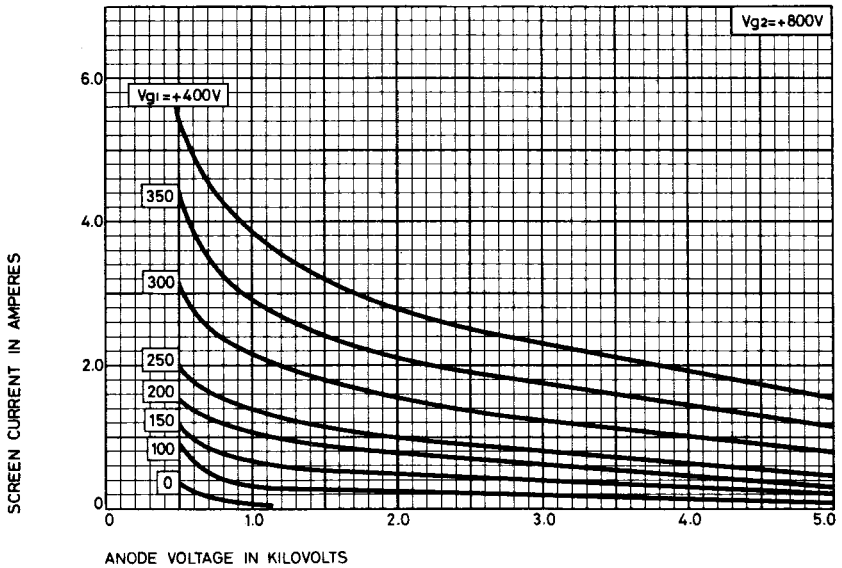
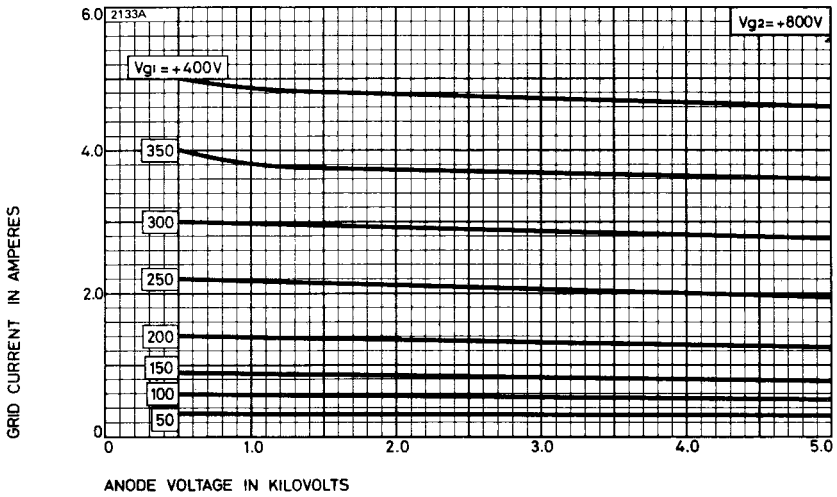

TYPICAL CONSTANT CURRENT CHARACTERISTICS

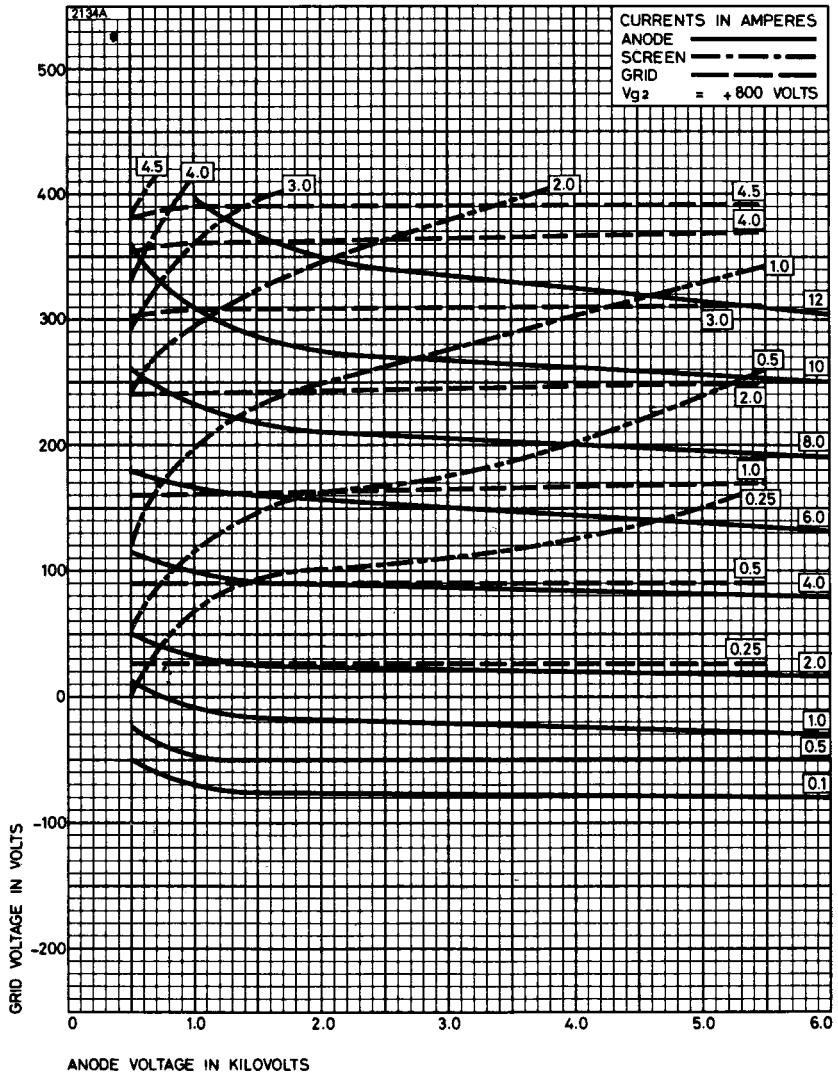

TYPICAL ANODE CHARACTERISTICS

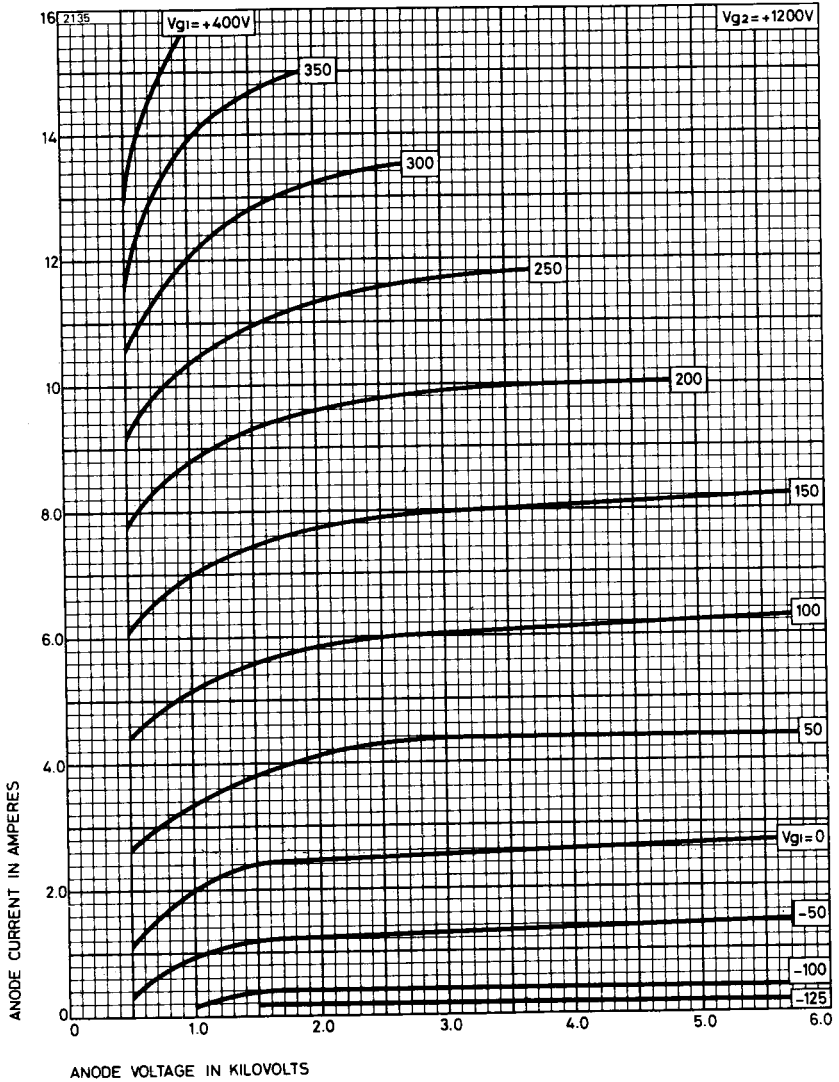

TYPICAL GRID AND SCREEN CHARACTERISTICS

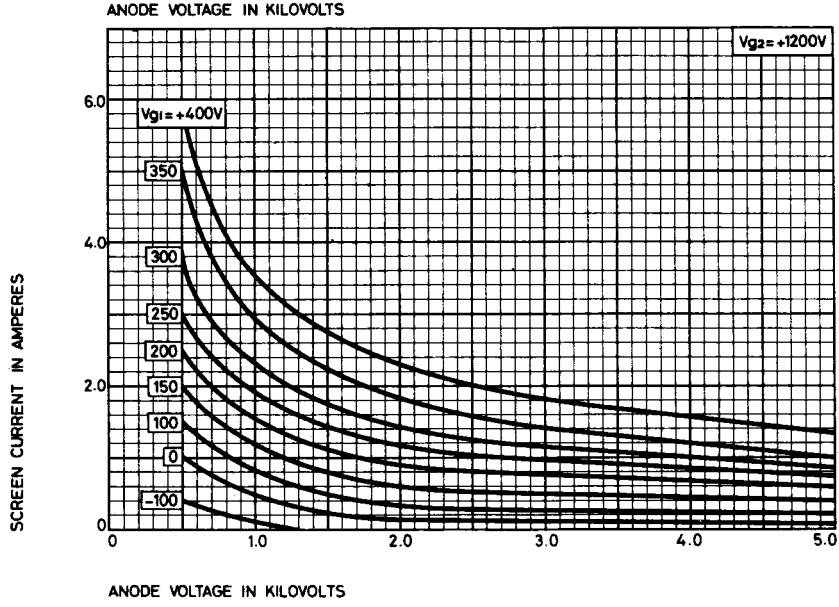
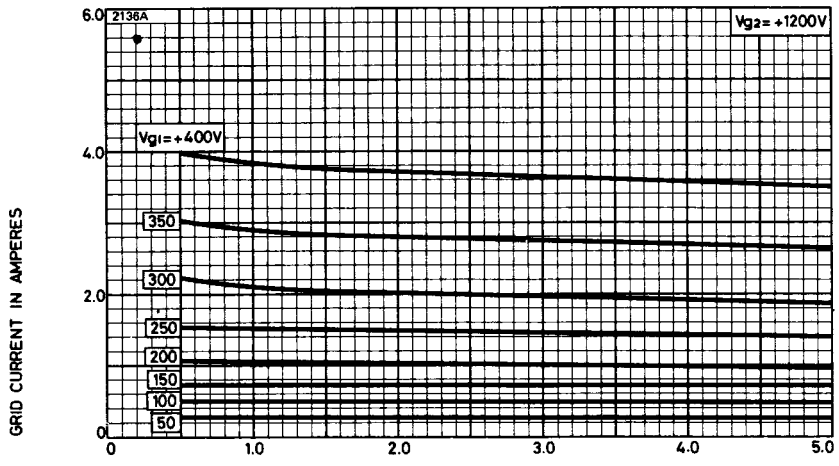

TYPICAL CONSTANT CURRENT CHARACTERISTICS

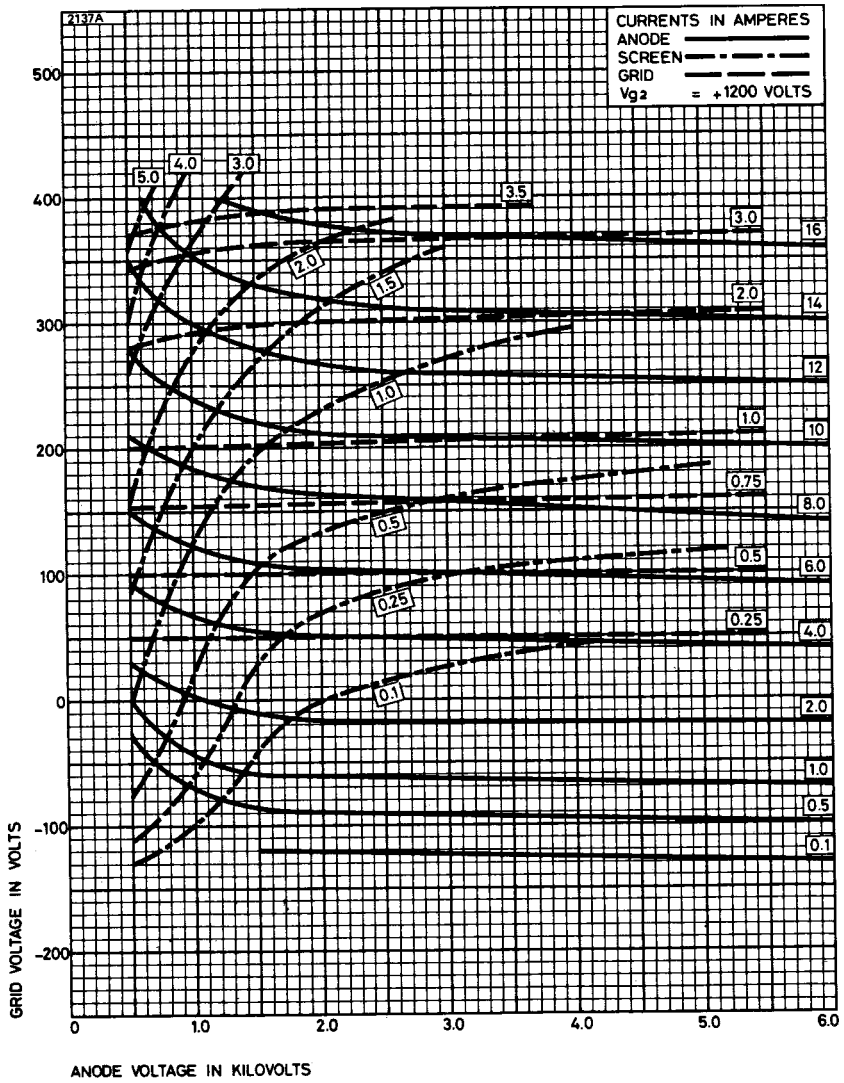

TYPICAL ANODE CHARACTERISTICS

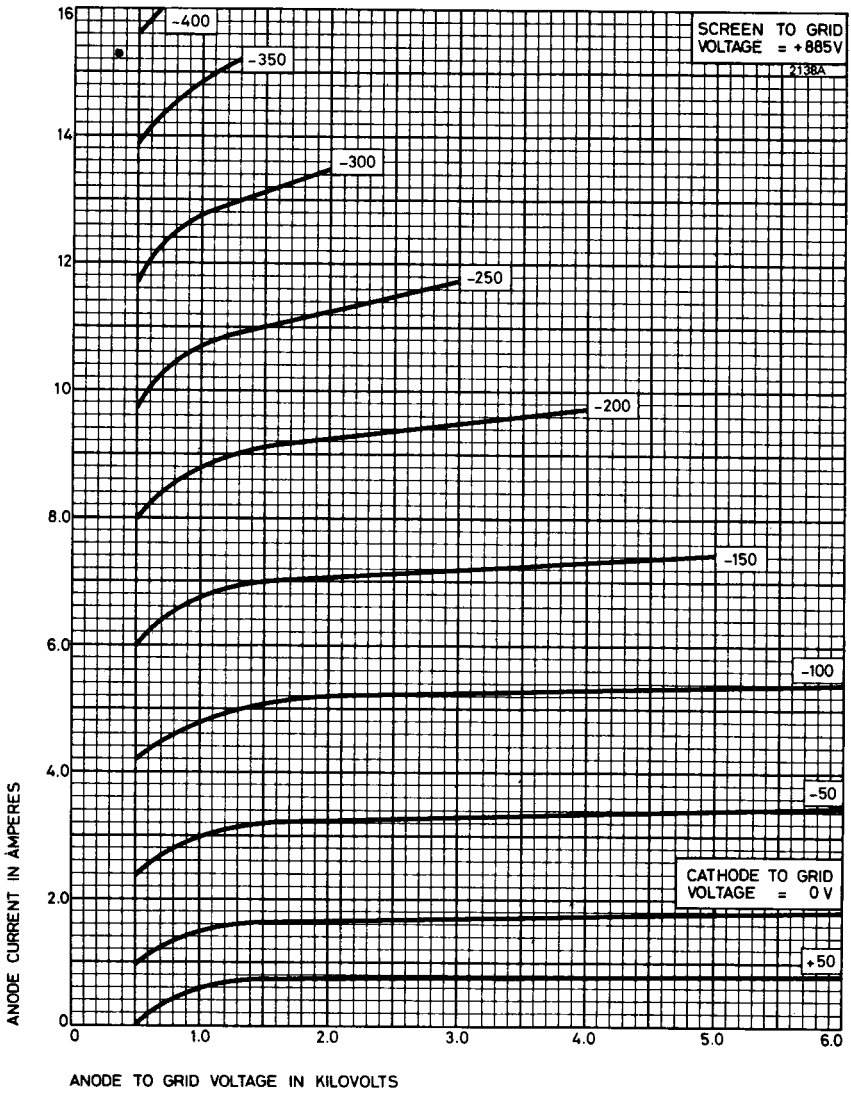

TYPICAL GRID AND SCREEN CHARACTERISTICS

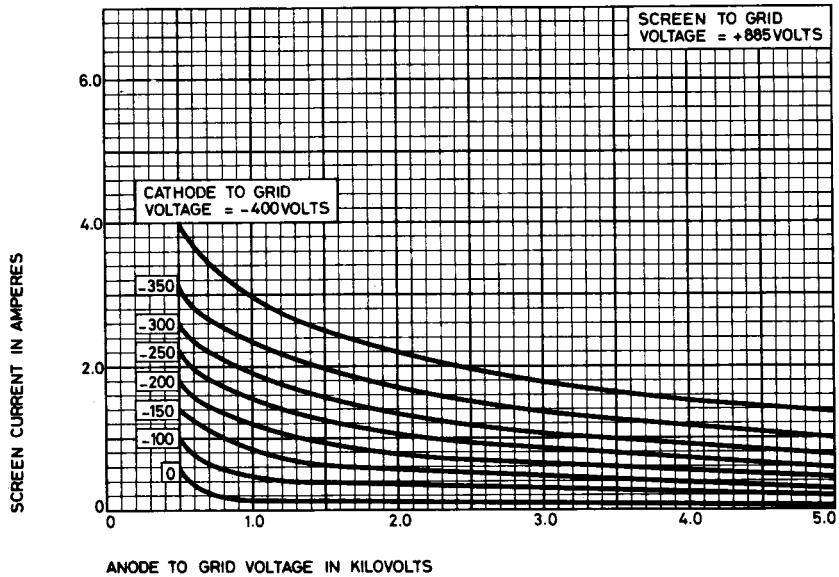
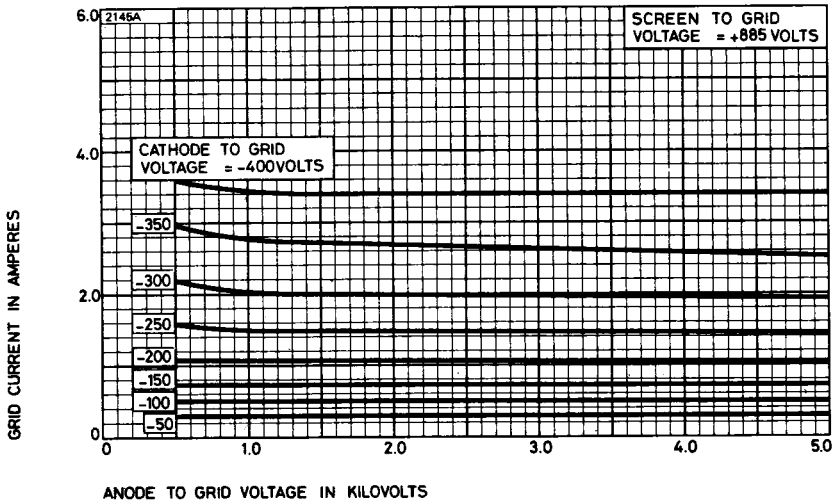

TYPICAL CONSTANT CURRENT CHARACTERISTICS

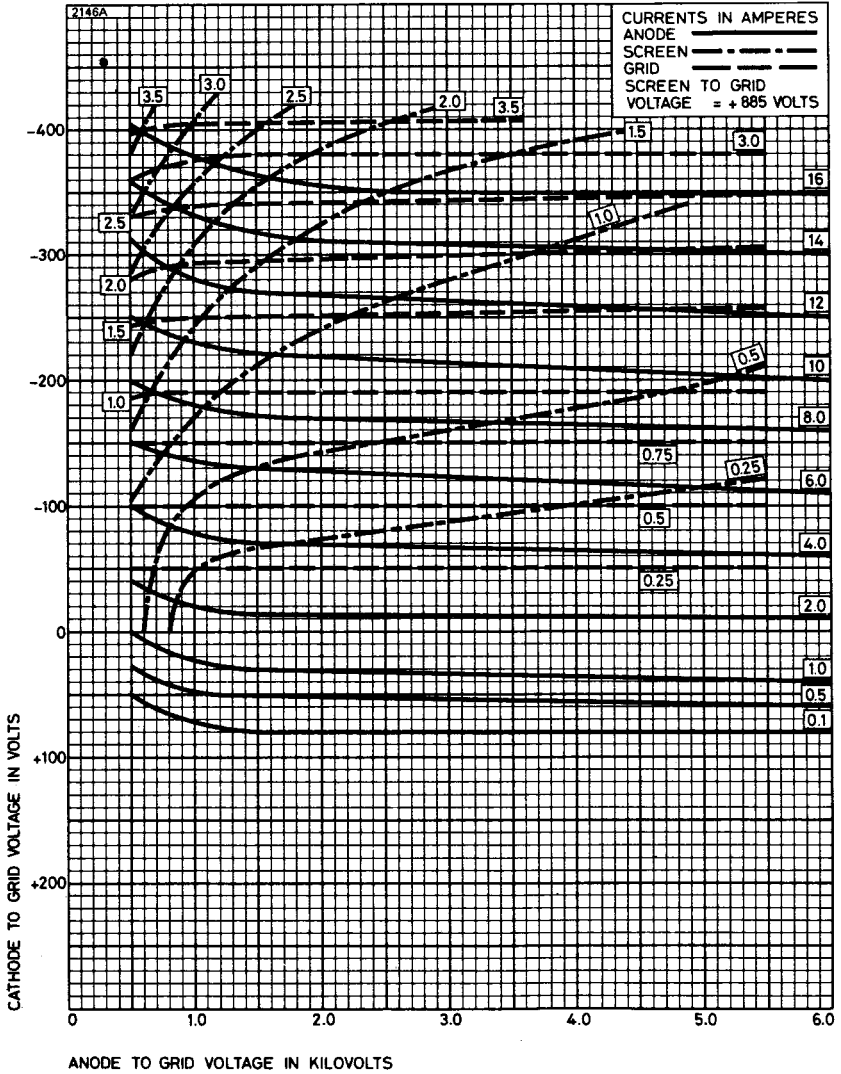

AIR COOLING REQUIREMENTS

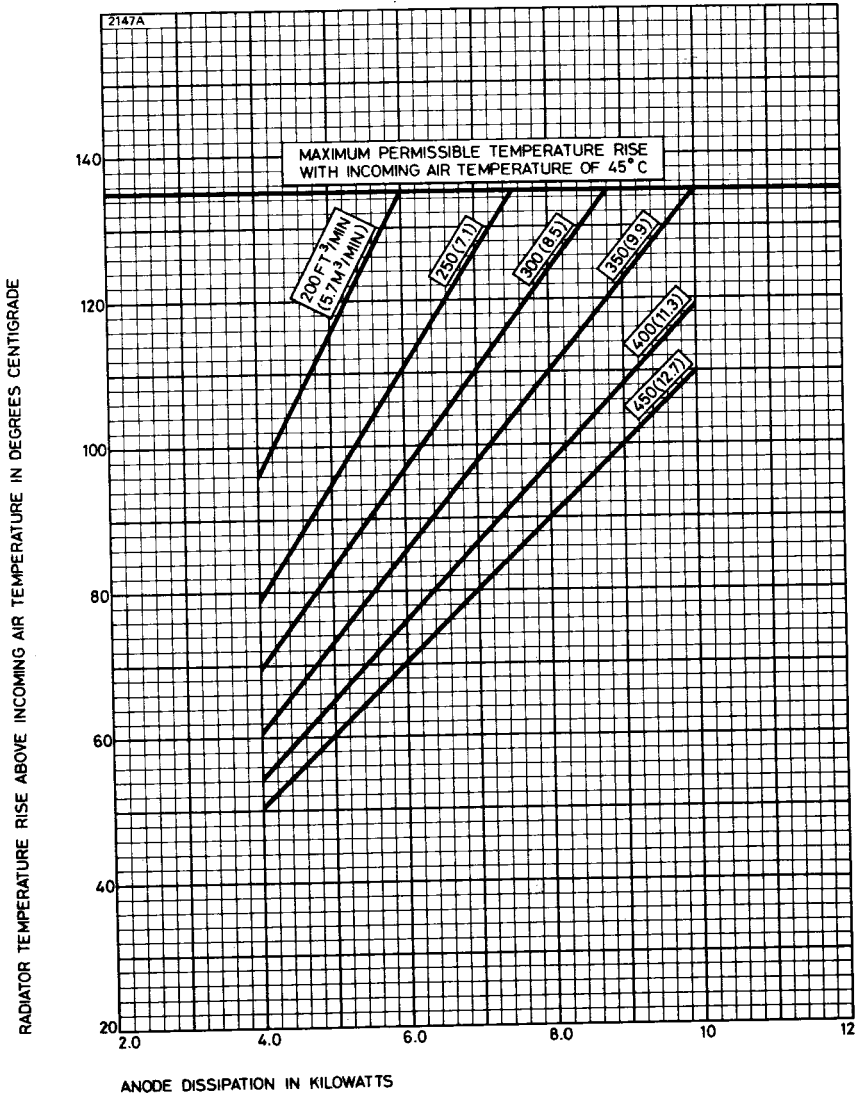

TYPICAL AIR FLOW CHARACTERISTIC

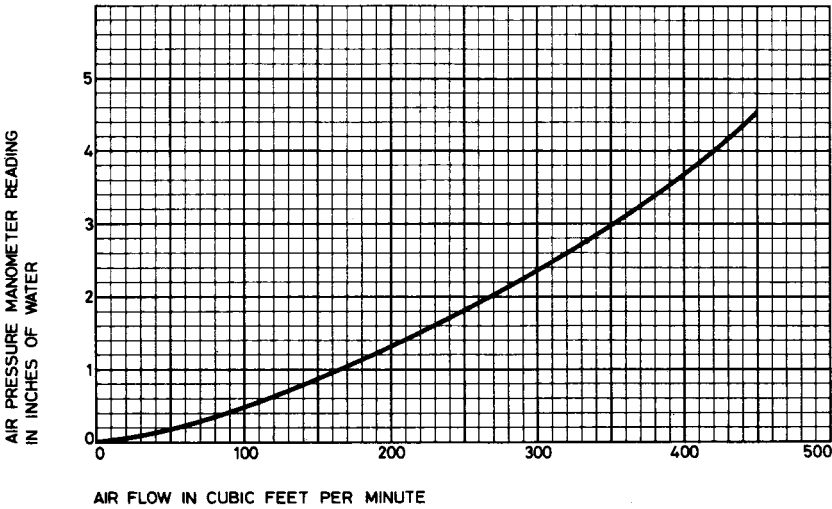
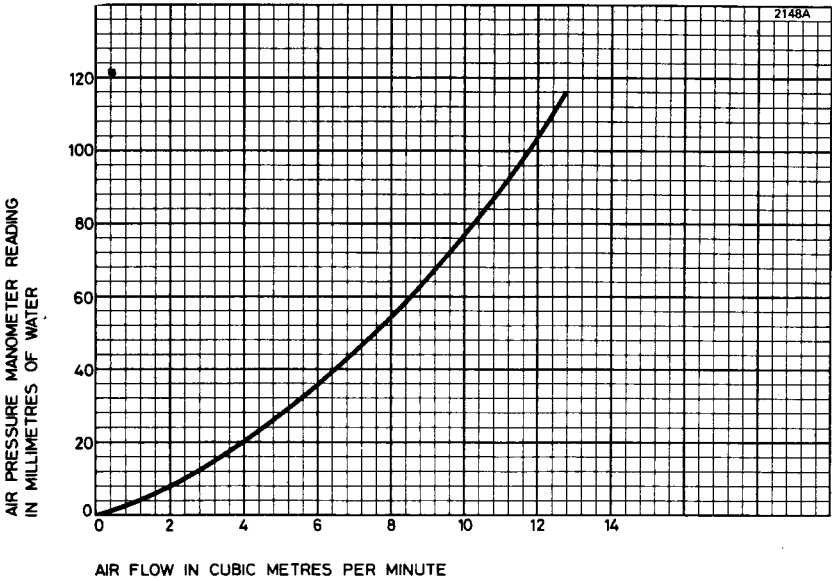

OUTLINE

2149

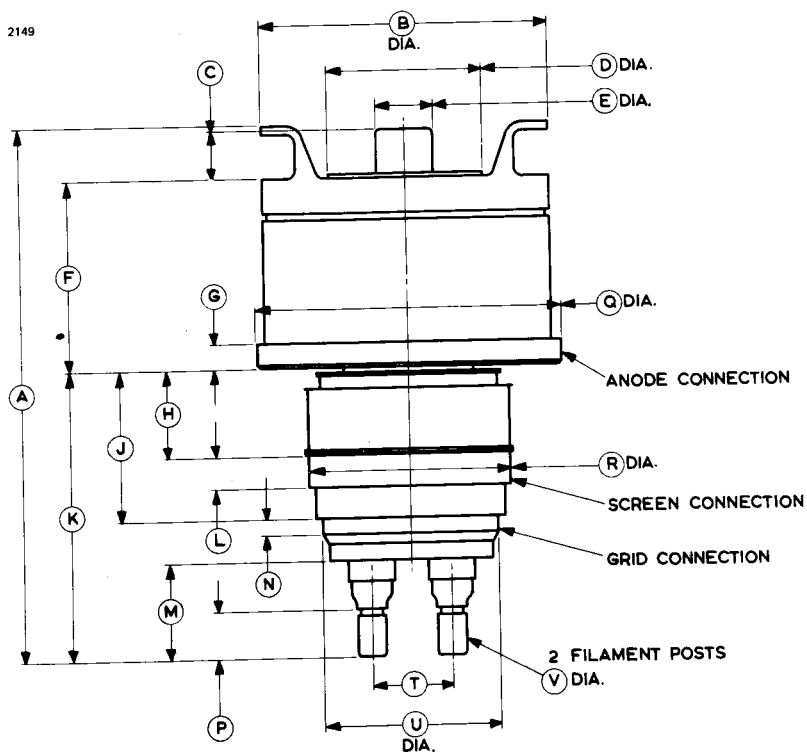

Ref	Inches	Millimetres	Ref	Inches	Millimetres
A	11.625 max	295.3 max	L	0.500 min	12.70 min
B	6.000 ± 0.094	152.4 ± 2.39	M	1.907 min	48.44 min
C	1.150 max	29.21 max	N	0.350 min	8.89 min
D	3.375 max	85.73 max	P	0.812 min	20.62 min
E	1.187	30.15	Q	6.375 ± 0.031	161.9 ± 0.79
F	4.094 max	104.0 max	R	4.248 ± 0.020	107.9 ± 0.51
G	0.500 ± 0.031	12.70 ± 0.79	T	1.710 ± 0.040	43.43 ± 1.02
H	1.846 ± 0.050	46.89 ± 1.27	U	3.685 ± 0.025	93.60 ± 0.64
J	3.151 ± 0.070	80.04 ± 1.79	V	0.625 ± 0.002	15.875 ± 0.051
K	6.094 ± 0.156	154.8 ± 3.96			

Millimetre dimensions have been derived from inches.

PUSH-ON FILAMENT ADAPTORS (Dimensions without limits are nominal)

MA136

MA137

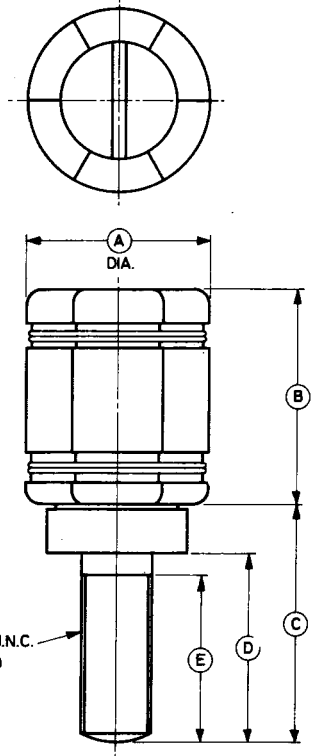
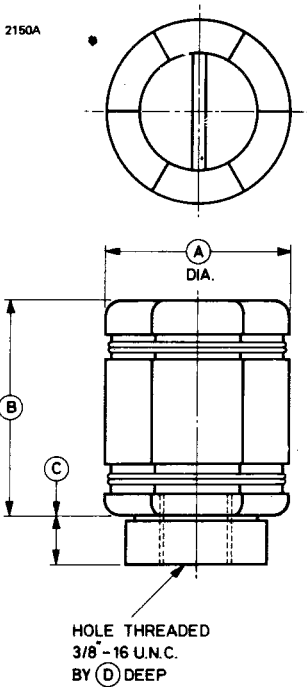

Ref	Inches	Millimetres
A	0.980	24.89
B	1.125	28.58
C	0.250	6.35
D	0.312	7.92

Ref	Inches	Millimetres
A	0.980	24.89
B	1.125	28.58
C	1.250	31.75
D	1.000	25.40
E	0.875 min	22.22 min

Millimetre dimensions have been derived from inches.

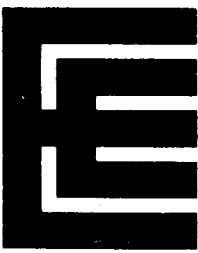

CY1170J

R.F. POWER TETRODE

The data should be read in conjunction with the Power Tetrode Preamble.

ABRIDGED DATA

Vapour-cooled tetrode with integral boiler, coaxial metal-ceramic envelope, for audio amplifiers, r.f. linear amplifiers or class C amplifiers or oscillators.

Anode dissipation	75	kW max
Anode voltage	15	kV max
Frequency for full ratings	30	MHz max
Output power (class C telegraphy)	82.5	kW



GENERAL

Electrical

Filament	thoriated tungsten
Filament voltage (see note 1)	10 V
Filament current	300 A
Grid-screen amplification factor	4.5
Inter-electrode capacitances, grounded filament:	
grid to anode	2.4 pF
input	465 pF
output	55 pF

Mechanical

Overall length	19.317 inches (490.7mm) max
Overall diameter	10.031 inches (254.8mm) max
Net weight	60 pounds (27kg) approx
Mounting position	vertical, anode up

Accessories

Sockets (see pages 10-12)	MA166A or MA166B
Clamping device to secure valve in socket (optional)	MA233

COOLING

The CY1170J has an integral boiler for vapour cooling. The steam generated when the valve is operating is ejected from the top of the boiler and passed through an insulated tube to a separate condenser. The condensate is returned to an inlet on the side of the boiler.

Sufficient air must be passed over the base terminals to maintain the temperatures of the ceramic to metal seals below the maximum rated value of 250°C.

Using socket type MA166 or MA166B, 60 to 100ft³/min (1.70 to 2.83m³/min) of air will be required for base cooling, blown horizontally through the socket from two diametrically opposed nozzles. It is also necessary to direct 2ft³/min (0.06m³/min) of air into the centre hole of the socket.

AUDIO FREQUENCY POWER AMPLIFIER AND MODULATOR (Class AB₁, See Note 2)

MAXIMUM RATINGS (Absolute values)

Anode voltage	15	kV max
Anode current	15	A max
Anode dissipation	75	kW max
Screen voltage	2.5	kV max
Screen dissipation	1750	W max
Grid dissipation	500	W max
Grid circuit resistance	0.1	MΩ max

TYPICAL OPERATING CONDITIONS (Class AB₁, two valves)

Anode voltage	10	15	kV
Screen voltage	1.5	1.5	kV
Grid voltage	-290	-340	V
Peak a.f. grid voltage	270	310	V
Anode current (zero signal)	4.0	2.0	A
Anode current (maximum signal)	17.4	15.1	A
Screen current (zero signal)	0	0	A
Screen current (maximum signal)	0.77	0.62	A
Anode dissipation per tube (maximum signal)	33	30.5	kW
Effective load (anode to anode)	1.15	2.56	kΩ
Nominal driving power (maximum signal)	0	0	W
Output power (maximum signal)	110	165	kW

RADIO FREQUENCY LINEAR AMPLIFIER (Class AB₁, See Note 2)

MAXIMUM RATINGS (Absolute values)

Anode voltage	15	kV max
Anode current	15	A max
Anode dissipation	75	kW max
Screen voltage	2.5	kV max
Screen dissipation	1750	W max
Grid dissipation	500	W max
Grid circuit resistance	0.1	MΩ max

TYPICAL OPERATING CONDITIONS

(Peak envelope or modulation crest conditions, below 30MHz)

Anode voltage	10	15	kV
Screen voltage	1.5	1.5	kV
Grid voltage (see note 3)	-290	-340	V
Peak r.f. grid voltage	270	310	V
Anode current (zero signal)	2.0	1.0	A
Anode current (maximum signal)	8.7	7.55	A
Screen current (maximum signal)	0.385	0.310	A
Anode dissipation	33	30.5	kW
Nominal driving power	0	0	W
Output power (see note 4)	55	82.5	kW

ANODE MODULATED R.F. POWER AMPLIFIER

(Class C Telephony, carrier conditions per valve for use with a maximum modulation factor of 1.0)

MAXIMUM RATINGS (Absolute values)

Anode voltage	12.5	kV max
Anode current	15	A max
Anode dissipation (see note 5)	50	kW max
Screen voltage	2.0	kV max
Screen dissipation	1750	W max
Grid dissipation	500	W max

TYPICAL OPERATING CONDITIONS (below 30MHz)

Anode voltage	7.5	10	kV
Screen voltage	750	750	V
Grid voltage	-460	-520	V
Peak a.f. screen voltage (for 100% modulation)	640	675	V
Peak r.f. grid voltage	630	680	V
Anode current	7.0	6.6	A
Screen current	1.2	0.985	A
Grid current	0.375	0.370	A
Anode dissipation	10.5	11.0	kW
Nominal driving power	235	250	W
Output power	42	55	kW

R.F. POWER AMPLIFIER OR OSCILLATOR

(Class C Telegraphy, key down conditions, one valve)

MAXIMUM RATINGS (Absolute values)

Anode voltage	15	kV max
Anode current	15	A max
Anode dissipation	75	kW max
Screen voltage	2.5	kV max
Screen dissipation	1750	W max
Grid dissipation	500	W max

TYPICAL OPERATING CONDITIONS (below 30MHz)

Anode voltage	10	15	kV
Screen voltage	750	750	V
Grid voltage	-425	-480	V
Peak r.f. grid voltage	575	640	V
Anode current	6.70	6.45	A
Screen current	0.925	0.810	A
Grid current	0.320	0.355	A
Anode dissipation	12	14	kW
Nominal driving power	185	225	W
Output power	55	82.5	kW

NOTES

1. The valve must be operated at the stated filament voltage. Fluctuation in filament voltage must not exceed $\pm 5\%$.
2. Grid current does not flow during any part of the drive cycle.
3. The grid voltage is adjusted to obtain the specified zero-signal anode current.
4. The peak envelope or r.f. output power at the crest of the modulation envelope.
5. This corresponds to 75kW anode dissipation at 100% sine wave modulation.

TYPICAL CONSTANT CURRENT CHARACTERISTICS

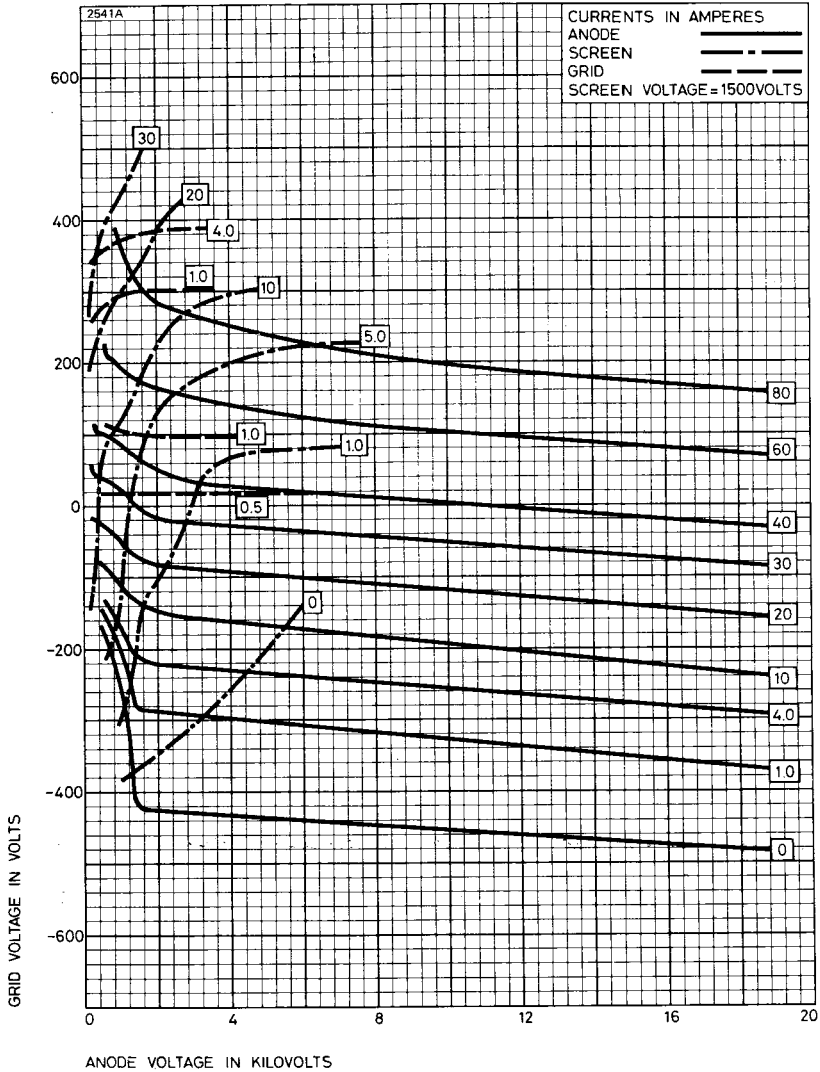

TYPICAL CONSTANT CURRENT CHARACTERISTICS

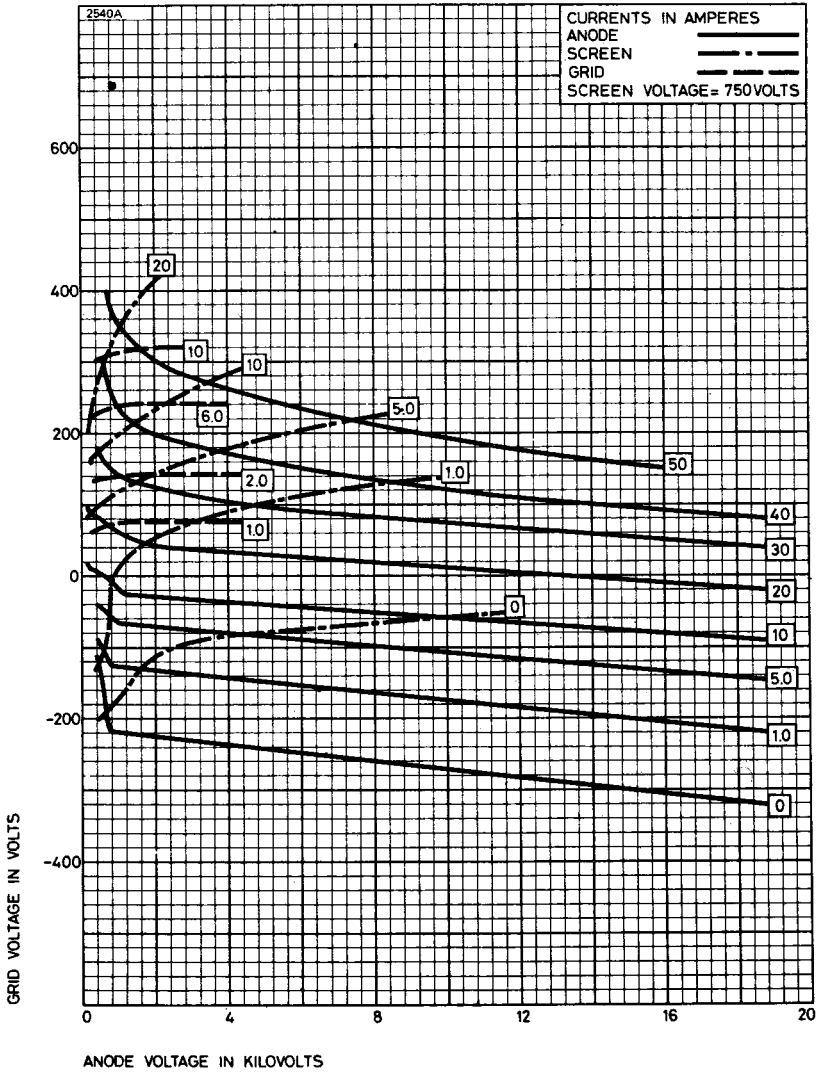

OUTLINE (All dimensions without limits are nominal)

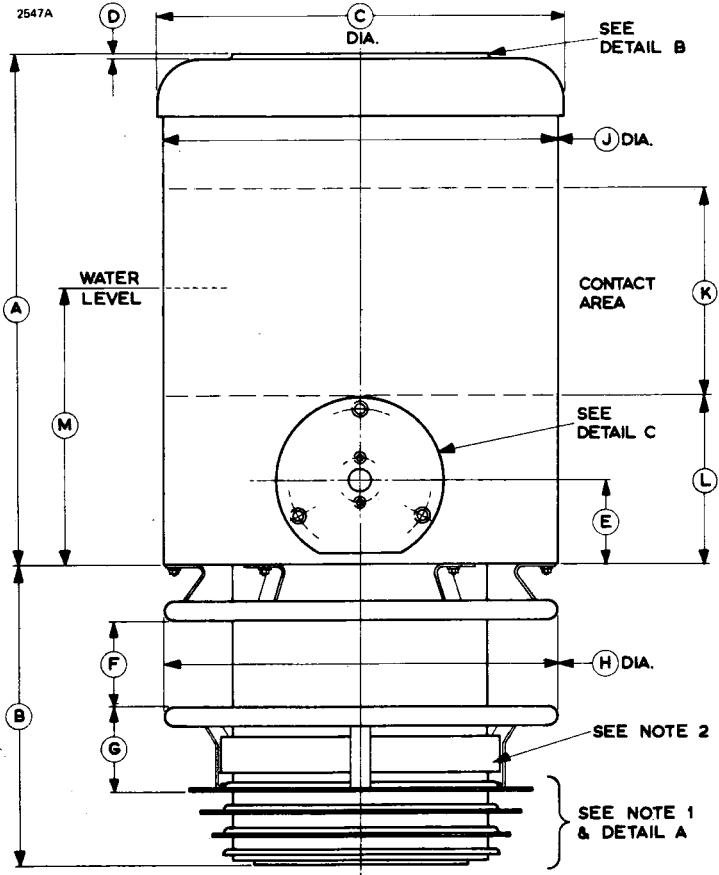

Ref	Inches	Millimetres	Ref	Inches	Millimetres
A	12.000 ± 0.125	304.8 ± 3.2	H	9.250	235.0
B	7.067 ± 0.125	179.5 ± 3.2	J	9.250	235.0
C	9.437	239.7	K	5.000	127.0
D	0.125	3.18	L	4.000	101.6
E	2.000 ± 0.062	50.80 ± 1.57	M	6.500 nom	165.1 nom
F	2.000	50.80		4.500 min	114.3 min
G	2.000	50.80			

Millimetre dimensions have been derived from inches.

Outline Detail A

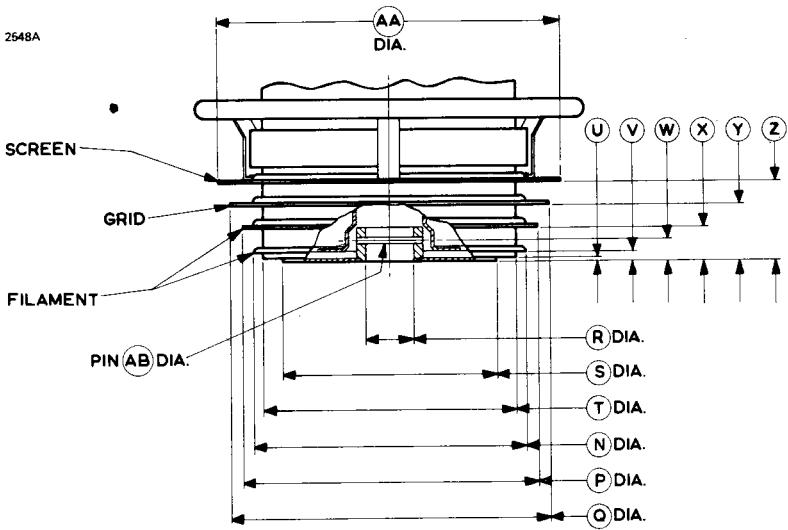

Outline Detail B

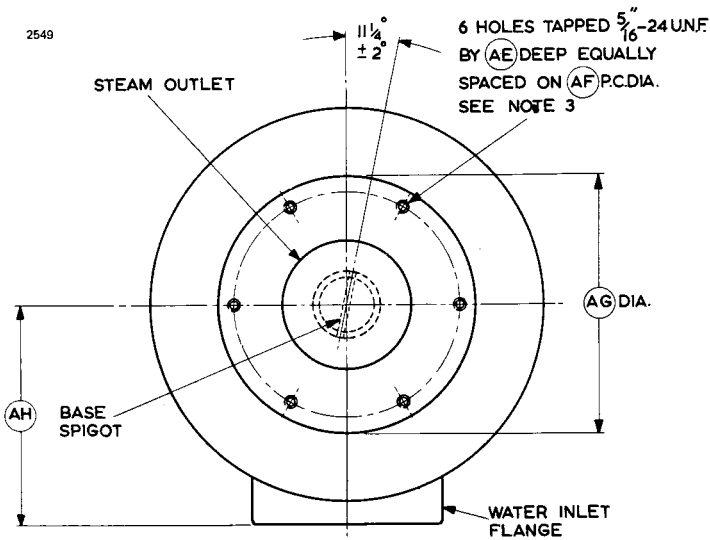

OUTLINE OF SOCKETS MA166 AND MA166B

(See pages 11 and 12 for plan views)

2543

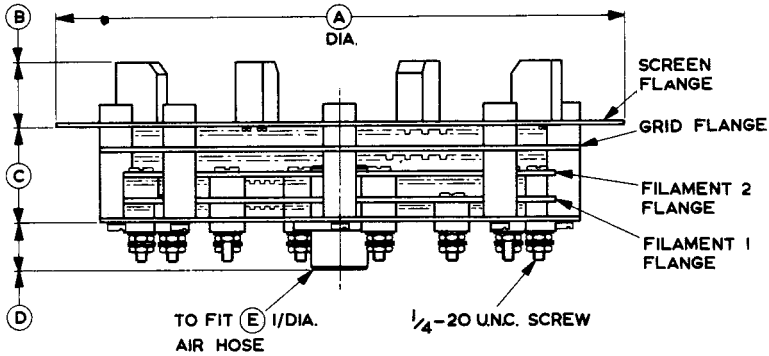

Ref	Inches	Millimetres
A	12.000 ± 0.015	304.8 ± 0.38
B	1.250 ± 0.156	31.75 ± 3.96
C	2.000 ± 0.020	50.80 ± 0.51
D	1.000 ± 0.020	25.40 ± 0.51
E	1.250	31.75
F	0.437	11.10
G	11.250	285.8
H	0.187	4.75
J	11.250	285.8
K	8.530	216.7
L	10.125 ± 0.031	257.2 ± 0.79
M	0.312	7.92
N	4.813	122.3

Millimetre dimensions have been derived from inches.

All dimensions without limits are nominal.

Plan view of MA166 (See page 10 for outline dimensions)

2544

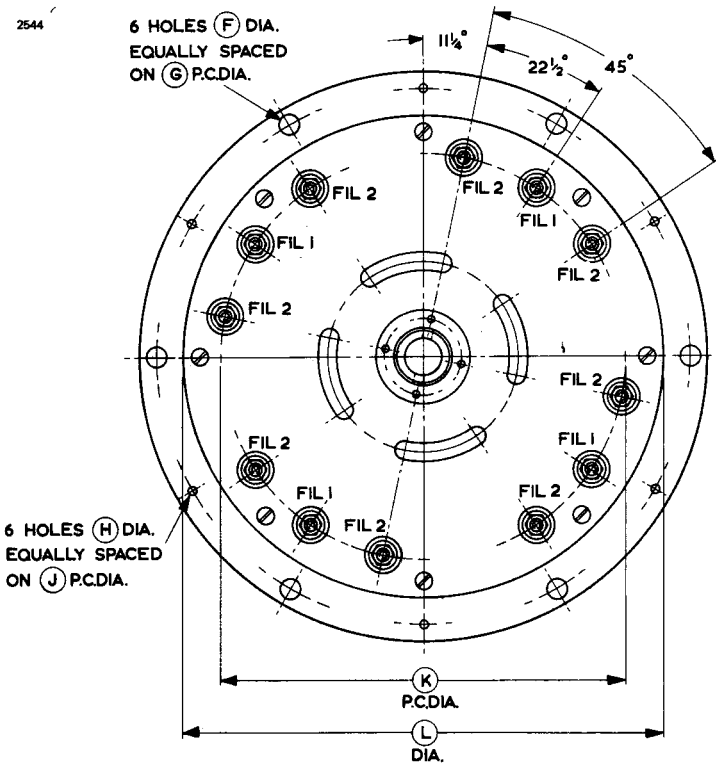



R.F. POWER TETRODE



The data should be read in conjunction with the Power Tetrode Preamble.

ABRIDGED DATA

Vapour-cooled tetrode of coaxial ceramic/metal construction, for audio amplifiers, r.f. linear amplifiers or class C amplifiers or oscillators.

Anode dissipation	150	kW max
Anode voltage	15	kV max
Frequency for full ratings	30	MHz max
Output power (class C, anode and screen modulated)	220	kW

GENERAL

Electrical

Filament		thoriated tungsten
Filament voltage (see note 1)	21	V
Filament current	350	A
Filament starting current (peak) (see note 2)	3000	A max
Filament cold resistance	12	mΩ
Peak usable cathode current	280	A
Grid-screen amplification factor ($V_a = 3.0\text{kV}$, $V_{g2} = 1.0\text{kV}$, $I_a = 10\text{A}$)	4.0	
Mutual conductance ($V_a = 3.0\text{kV}$, $V_{g2} = 1.0\text{kV}$, $I_a = 10\text{A}$)	130	mA/V
Perveance	8	mA/V ^{3/2}
Inter-electrode capacitances:		
anode to grid (see note 3)	8.5	pF
anode to cathode (see note 3)	1.7	pF
anode to screen	118	pF
cathode to grid	260	pF
grid to screen	340	pF

Mechanical

Overall length	21.004 inches (533.5mm) max
Overall diameter	12.480 inches (317mm) max
Net weight	112 pounds (51kg) approx
Mounting position	vertical, anode down

Boiler Unit and Accessories

The CY4120 is a single boiler unit for use with CY1172. A separate condenser is required, with insulating pipes for the steam outlet and water return to the boiler. The valve is held in the boiler unit by its own weight.

The boiler unit may be mounted by means of the four pillars on the base, and these may also be used for h.t. supply connections.

Distilled or de-mineralized water should be used in the boiler unit.

Net weight (empty)	100 pounds (45kg) approx
Water capacity to maximum water level	6.5 imp. gal (30 l.) approx
Sealing ring (supplied with boiler)	MA320
Socket (see page 10)	MA226
Thermal fuse	MA85C

COOLING AND INSTALLATION

The CY1172 is designed for cooling by vaporization of water and is fitted with an integral anode block in which circulation holes are provided for the passage of water and steam. The valve is installed with the anode partly immersed in the liquid coolant (distilled or de-ionized water) inside the boiler unit (see list of accessories above). When the power supplies are switched on the heat generated inside the valve evaporates some of the water in the circulation holes and jets of steam issue into the upper part of the boiler. The steam is either condensed directly by means of an internal water cooled condenser or led away by suitable insulated tubing for condensation at some convenient point external to the boiler (as in CY4120).

The services of our design staff are available for advice in matters of suitable condenser design and installation details.

The temperature of the filament and grid metal-ceramic seals must not exceed 220°C. A flow of air of 60ft³/min (1.7m³/min) directed into the filament header via a 1-inch (25mm approx) diameter nozzle before and during the application of any voltages is usually adequate for seal cooling.

The glass seals and bulb temperatures must not exceed 180°C.

A thermal fuse (part number MA85C) is provided with each valve to give protection against anode overheating. A position for mounting the thermal fuse is provided by a threaded hole in the top surface of the anode ring. It should be connected by a non-conducting cord to a suitable switching device; a tension of about 1 lb (450g) should be applied to the fuse via the cord. If the temperature exceeds a safe limit, the fuse core is pulled outwards; this should actuate the switching device and remove all electrical supplies from the valve. Replacement fuses can be supplied to order. An additional hole threaded M5 is provided, to accept existing fuses in certain equipments.

ANODE AND SCREEN MODULATED R.F. POWER AMPLIFIER

(Class C Telephony, carrier conditions per valve for use with a maximum modulation factor of 1.0)

MAXIMUM RATINGS (Absolute values)

Anode voltage	11.5	kV max
Screen voltage	1000	V max
Grid voltage (negative value)	800	V max
Cathode current	60	A max
Anode dissipation (see note 4)	100	kW max
Screen dissipation (see note 5)	2700	W max
Grid dissipation	1200	W max

TYPICAL OPERATING CONDITIONS (below 30MHz)

Anode voltage	11.0	kV
Screen voltage	800	V
Grid voltage	-590	V
Peak r.f. grid voltage	910	V
Anode current	25	A
Screen current	2.2	A
Grid current	1.5	A
Anode dissipation	55	kW
Screen dissipation	1.8	kW
Grid dissipation	480	W
Driving power	1.2	kW
Output power	220	kW
Efficiency	80	%

RADIO FREQUENCY LINEAR AMPLIFIER

(Class AB1 – see note 6)

MAXIMUM RATINGS (Absolute values)

Anode voltage	15	kV max
Screen voltage	1600	V max
Grid voltage (negative)	800	V max
Cathode current	60	A max
Anode dissipation	150	kW max
Screen dissipation	2700	W max
Grid dissipation	1200	W max



TYPICAL OPERATING CONDITIONS (below 30MHz)

Anode voltage	9			kV
Screen voltage	1500			V
Grid voltage	-450			V
		zero	single	two tone
		signal	tone	(average)
Peak r.f. grid voltage	0	450	450	V
Anode current	5	21	13.2	A
Screen current	0	0.8	0.5	A
Anode dissipation	45	69	58.5	kW
Screen dissipation	0	1200	750	W
Output power	0	120	60	kW
Efficiency	-	63.5	50.5	%

NOTES

1. The valve must be operated at the stated filament voltage within +1% and -3%.
2. The filament current must not exceed 3000A, even momentarily, at any time.
3. Measured with a screening plate 50cm diameter, mounted perpendicular to the valve axis on the screen contact.
4. This value corresponds to 150kW anode dissipation at 100% sine wave modulation.
5. This value must not be exceeded at any level of modulation.
6. Grid current does not flow during any part of the drive cycle.

CONSTANT CURRENT CHARACTERISTICS

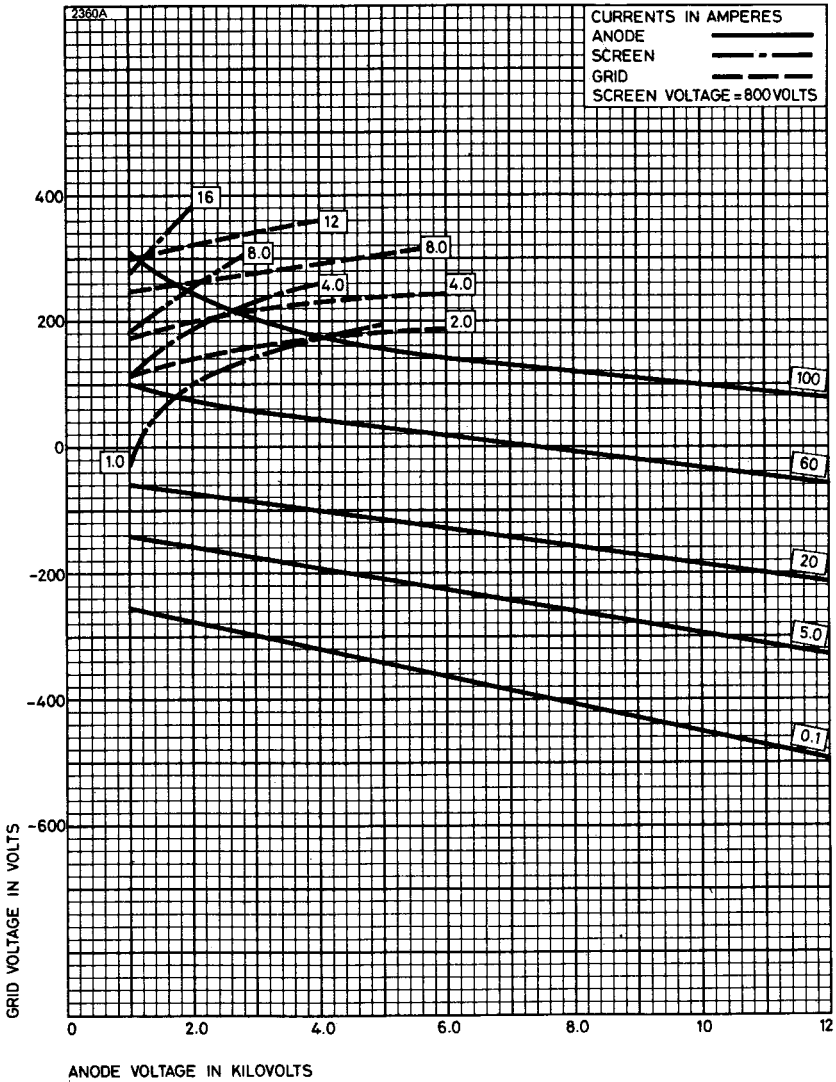

CONSTANT CURRENT CHARACTERISTICS

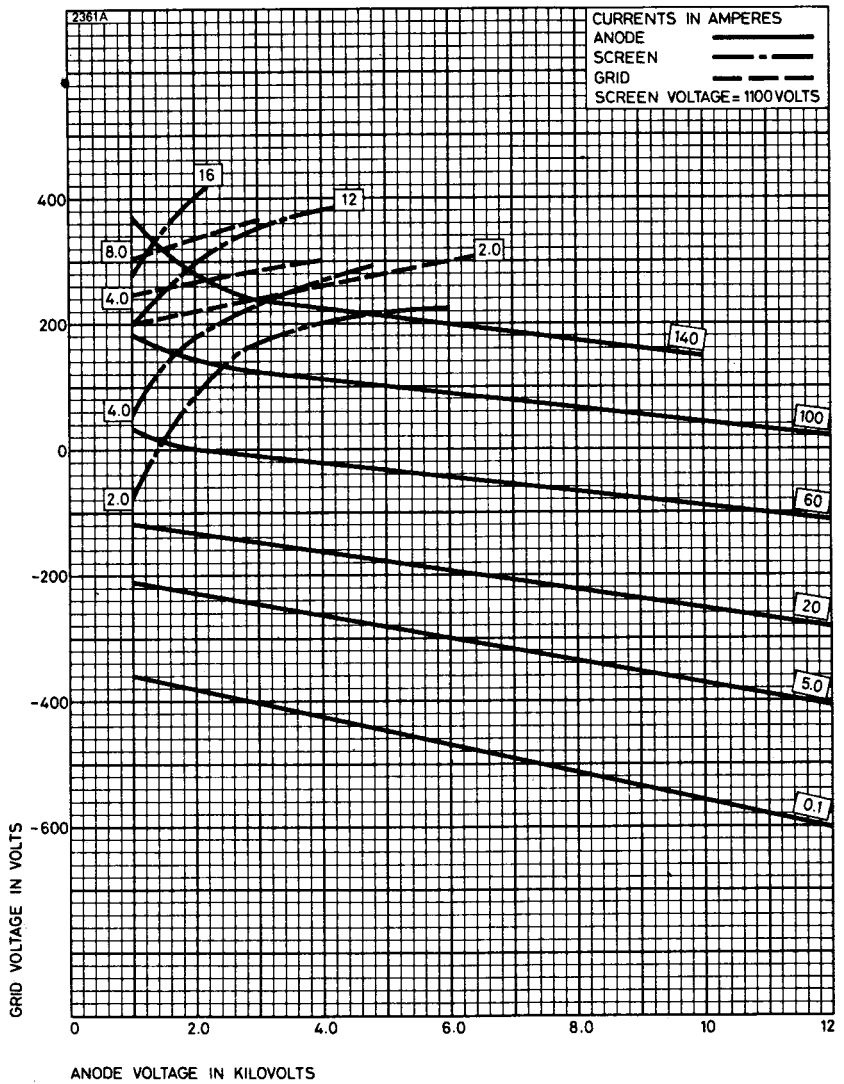

CONSTANT CURRENT CHARACTERISTICS

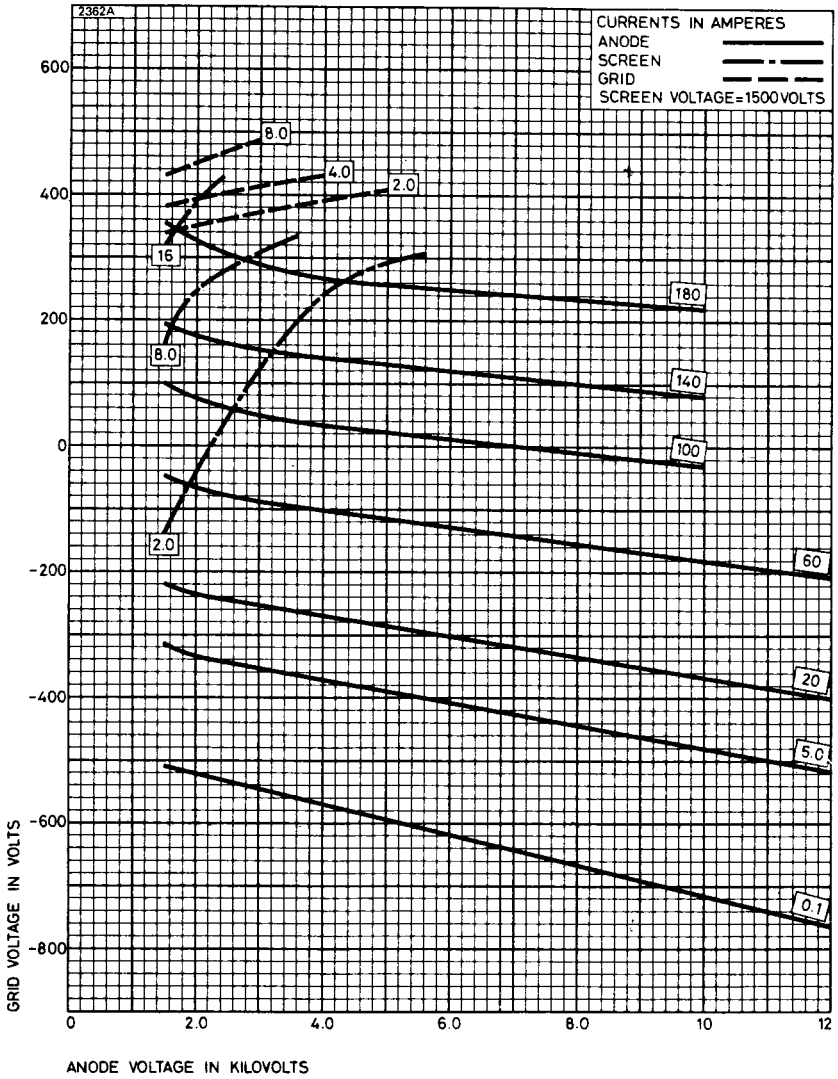

OUTLINE (All dimensions without limits are nominal)

2346

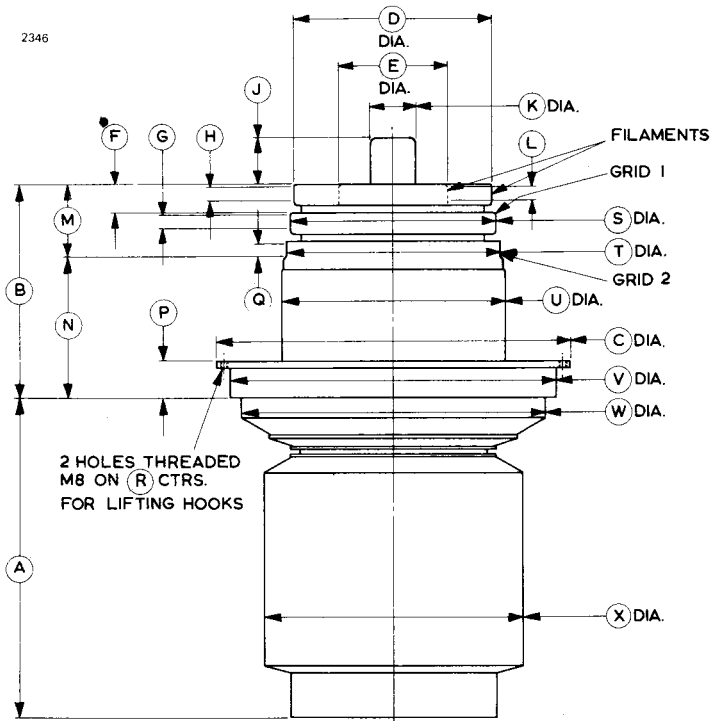

Ref	Millimetres	Inches	Ref	Millimetres	Inches
A	289.0 ± 5.0	11.378 ± 0.197	N	125.3 ± 2.0	4.933 ± 0.079
B	192.8	7.591	P	34.00 ^{+0.5} _{-0.0}	1.339 ^{+0.020} _{-0.000}
C	315.0	12.402	Q	15.0 ^{+2.0} _{-3.5}	0.591 ^{+0.079} _{-0.138}
D	178.0 ± 0.5	7.008 ± 0.020	R	300.0	11.811
E	96.00 ± 0.5	3.780 ± 0.020	S	185.0 ± 0.5	7.284 ± 0.020
F	24.2 ± 0.5	0.953 ± 0.020	T	193.2 ± 0.5	7.606 ± 0.020
G	15.00	0.591	U	208 max	8.189 max
H	15.00	0.591	V	290.0	11.417
J	42.50 ^{+0.0} _{-2.0}	1.673 ^{+0.000} _{-0.079}	W	270.0	10.630
K	40.00	1.575	X	230.0	9.055
L	15.00	0.591			
M	67.5 ^{+1.0} _{-2.0}	2.657 ^{+0.039} _{-0.079}			

Inch dimensions have been derived from millimetres.

OUTLINE FOR BOILER CY4120

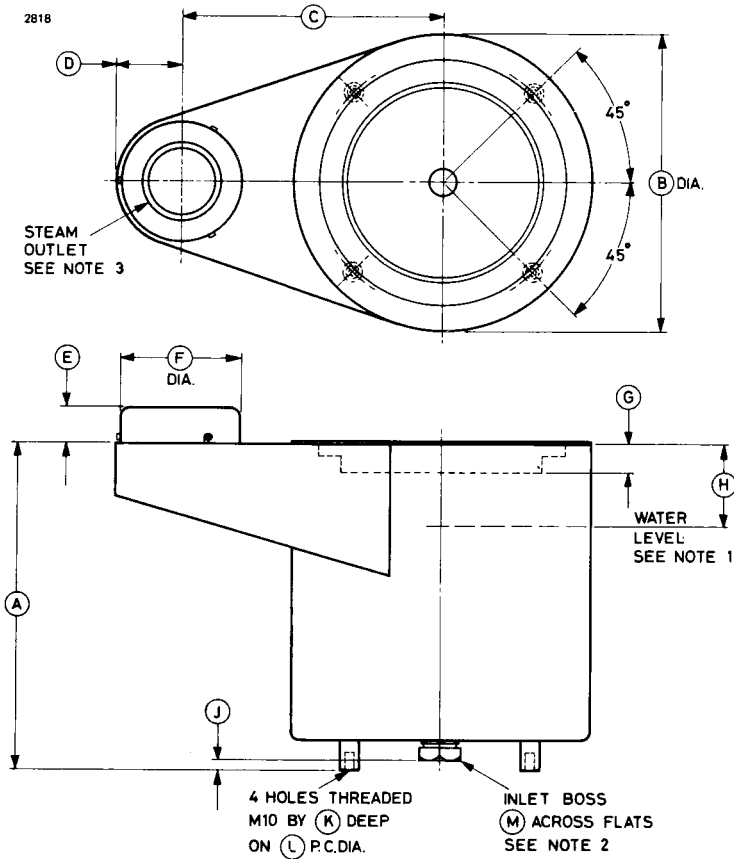

Outline Notes

1. This is the nominal water level for setting-up. The level must not fall below 160mm (6.299 inches) under maximum anode dissipation. The CY4120 can be supplied with a water level indicator if required.
2. An inlet water tube MA239, and adaptor MA347, can be supplied.
3. The following fittings are recommended for the steam outlet; they are not supplied with the boiler:

(a) Steam outlet pipe MA346.	(d) One rubber insert CNR4*.
(b) One backing flange CF4*.	(e) Two gaskets CGB/4*.
(c) One PTFE bellows FB4*.	(f) Six bolts NB4*.

* Available from Q.V.F. Limited, Duke Street, Fenton, Stoke-on-Trent, Staffordshire.

Outline Dimensions for CY4120 (All dimensions without limits are nominal)

Ref	Millimetres	Inches	Ref	Millimetres	Inches
A	440.0	17.323	G	39.0 ± 1.0	1.535 ± 0.039
B	400.0	15.748	H	110.0	4.331
C	350.0	13.780	J	25.0	0.984
D	85.0	3.346	K	25.0 min	0.984 min
E	48.0	1.890	L	330.0	12.992
F	160.0	6.299	M	55.0	2.165

Inch dimensions have been derived from millimetres.

SOCKET MA226

The MA226 provides connections to the filament and grids of the CY1172; it incorporates filament bypass and screen decoupling capacitors, and protective spark gaps for grid and screen. The outer shell of the socket forms a corona ring, to give flashover protection to the valve envelope.

Schematic Diagram for MA226

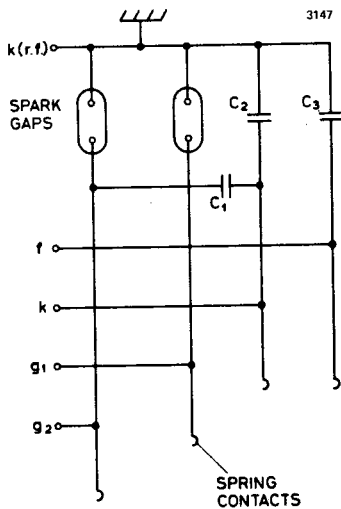

- C1 10 ceramic capacitors, 6800pF 3500V working
- C2 6 mica capacitors, 470 000pF 500V working
- C3 6 mica capacitors, 470 000pF 500V working

Outline for Socket MA226

3144

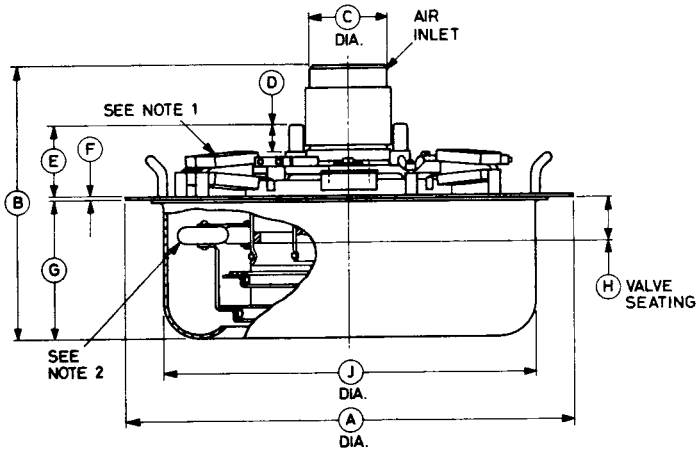
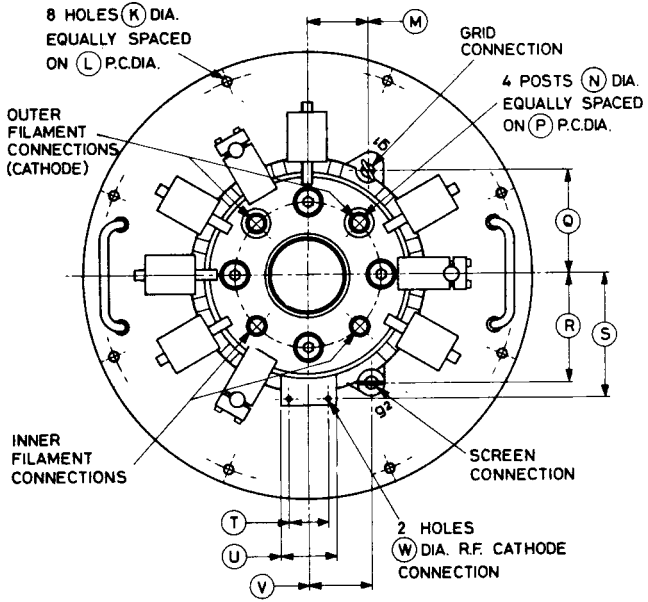

Outline Notes

1. Filament bypass capacitors.
2. Screen decoupling capacitors.

Outline Dimensions for MA226 (All dimensions without limits are nominal)

Ref	Millimetres	Inches
A	400.0	15.748
B	243.0	9.567
C	69.0 ± 0.5	2.717 ± 0.020
D	24.0	0.945
E	65.0	2.559
F	3.0	0.118
G	123.0	4.843
H	38.0	1.496
J	330.0	12.992
K	9.0	0.354
L	375.0	14.764
M	54.0	2.126
N	15.0 ± 0.1	0.591 ± 0.004
P	130.0	5.118
Q	93.5	3.681
R	98.0	3.858
S	111.0	4.370
T	34.0	1.339
U	50.0	1.969
V	56.5	2.224
W	4.5	0.177

Inch dimensions have been derived from millimetres.

Power Pentode





5CX1500A

R.F. POWER PENTODE

The data should be read in conjunction with the Power Tetrode Preamble.

ABRIDGED DATA

Forced-air cooled pentode, coaxial metal-ceramic envelope, for use in class AB₁ linear amplifiers in audio and radio frequency applications. It is also recommended for use in class C amplifiers.

Anode dissipation	1.5	kW max
Anode voltage	5.0	kV max
Frequency for full ratings	110	MHz max
Output power (two valves, class AB ₁ audio)	3.2	kW



GENERAL

Electrical

Filament		thoriated tungsten
Filament voltage (see note 1)	5.0	V
Filament current	40	A
Mutual conductance ($V_a = 2.0kV$, $V_{g2} = 500V$, $I_a = 1.0A$)	24	mA/V
Grid-screen amplification factor	5.5	
Inter-electrode capacitances, grounded cathode:		
grid to anode	0.11	pF
input	77	pF
output	16	pF

Mechanical

Overall length	4.950 inches (125.7mm) max
Overall diameter	3.370 inches (85.60mm) max
Net weight	2 pounds (0.9kg) approx
Mounting position	vertical, either way up

COOLING

Sufficient air must be passed through the radiator and over the ceramic to metal seals to maintain the temperatures below the maximum rated values of:

Anode core	250	°C max
Ceramic to metal seals	250	°C max

Air flow requirements to maintain the seal temperatures at 225°C with an ambient temperature of 50°C and operating frequency less than 30MHz are

given below. The figures specified take into account the grid and filament dissipations.

Anode dissipation (kW)	Sea level		6000 feet	
	Air flow (ft ³ /min)	Pressure drop (in. water gauge)	Air flow (ft ³ /min)	Pressure drop (in. water gauge)
1.0	27	0.33	33	0.40
1.5	47	0.76	58	0.95

At other altitudes and ambient temperatures, the air flow must be adjusted to give equivalent cooling.

AUDIO FREQUENCY POWER AMPLIFIER OR MODULATOR (Class AB)

MAXIMUM RATINGS (Absolute values)

Anode voltage	4.0	kV max
Anode current	1.0	A max
Anode dissipation	1.5	kW max
Screen voltage	750	V max
Screen dissipation	75	W max
Grid dissipation	25	W max
Suppressor dissipation	25	W max

TYPICAL OPERATING CONDITIONS

(Class AB1, two valves) (See note 2)

Anode voltage	2.8	3.8	kV
Screen voltage	500	500	V
Grid voltage (see note 2)	-81	-83	V
Suppressor voltage	0	0	V
Peak a.f. grid drive voltage	81	83	V
Anode current (zero signal)	500	500	mA
Anode current (maximum signal)	1.30	1.33	A
Screen current (zero signal) (approx)	20	20	mA
Screen current (maximum signal) (approx)	110	106	mA
Effective load (anode to anode)	4.8	6.72	kΩ
Nominal driving power (maximum signal)	0	0	W
Anode dissipation per tube (maximum signal)	720	1130	W
Output power (maximum signal)	2.2	3.22	kW

RADIO FREQUENCY LINEAR AMPLIFIER (Class AB)

MAXIMUM RATINGS (Absolute values)

Anode voltage	4.0	kV max
Anode current	1.0	A max
Anode dissipation	1.5	kW max
Screen voltage	750	V max
Screen dissipation	75	W max
Grid dissipation	25	W max
Suppressor dissipation	25	W max

TYPICAL OPERATING CONDITIONS

(at frequencies below 30MHz)

Anode voltage	2.5	3.0	4.0	kV
Screen voltage	500	500	500	V
Grid voltage (see note 2)	-87	-89	-90	V
Suppressor voltage	0	0	0	V
Peak r.f. grid drive voltage	87	89	90	V
Anode current:				
zero signal	250	250	250	mA
single tone	660	690	690	mA
two tone (average)	468	482	485	mA
Screen current:				
single tone	79	71	59	mA
two tone	36	32	25	mA
Nominal driving power	0	0	0	W
Load impedance	2.34	2.68	3.50	k Ω
Output power	1.09	1.33	1.78	kW



ANODE MODULATED R.F. POWER AMPLIFIER

(Class C telephony, carrier conditions per valve for use with a maximum modulation factor of 1.0)

MAXIMUM RATINGS (Absolute values)

Anode voltage	3.5	kV max
Anode current	0.8	A max
Anode dissipation (see note 3)	1.0	kW max
Screen voltage	550	V max
Screen dissipation	75	W max
Grid dissipation	25	W max
Suppressor dissipation	25	W max

TYPICAL OPERATING CONDITIONS

Anode voltage	2.5	3.2	kV
Screen voltage	500	500	V
Grid voltage	-260	-260	V
Suppressor voltage	0	0	V
Peak r.f. grid voltage	315	315	V
Peak a.f. screen modulating voltage (modulation factor 1.0)	500	500	V
Anode current	800	800	mA
Screen current	90	86	mA
Grid current	32	32	mA
Nominal driving power	10	10	W
Anode dissipation	530	576	W
Load impedance	1.36	1.86	k Ω
Output power	1.47	1.96	kW

R.F. POWER AMPLIFIER OR OSCILLATOR

(Class C telegraphy, key down conditions, one valve)

MAXIMUM RATINGS (Absolute values)

Anode voltage	5.0	kV max
Anode current	1.0	A max
Anode dissipation	1.5	kW max
Screen voltage	750	V max
Screen dissipation	75	W max
Grid dissipation	25	W max
Suppressor dissipation	25	W max

TYPICAL OPERATING CONDITIONS

Anode voltage	3.0	4.0	4.5	kV
Screen voltage	500	500	500	V
Grid voltage	-200	-200	-200	V
Suppressor voltage	0	0	0	V
Peak r.f. grid voltage	255	245	255	V
Anode current	900	800	900	mA
Screen current	94	66	88	mA
Grid current	35	25	34	mA
Anode dissipation	720	850	870	W
Load impedance	1.57	2.24	2.52	k Ω
Nominal driving power	9.0	6.5	9.0	W
Output power	1.98	2.35	3.18	kW



NOTES

1. The valve must be operated at the stated filament voltage. Fluctuation in filament voltage must not exceed $\pm 5\%$.
2. Adjusted to give the specified zero signal anode current.
3. This value corresponds to 1.5kW at 100 per cent sine-wave modulation.

TYPICAL CONSTANT CURRENT CHARACTERISTICS

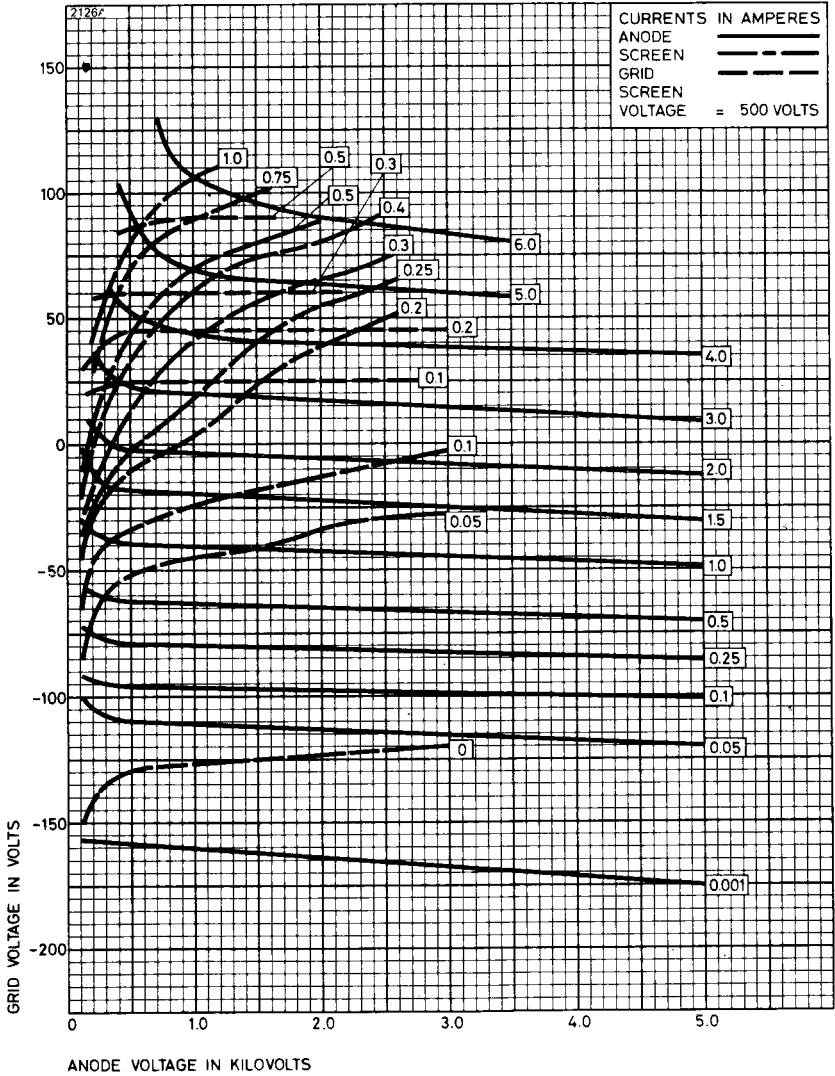

TYPICAL CONSTANT CURRENT CHARACTERISTICS

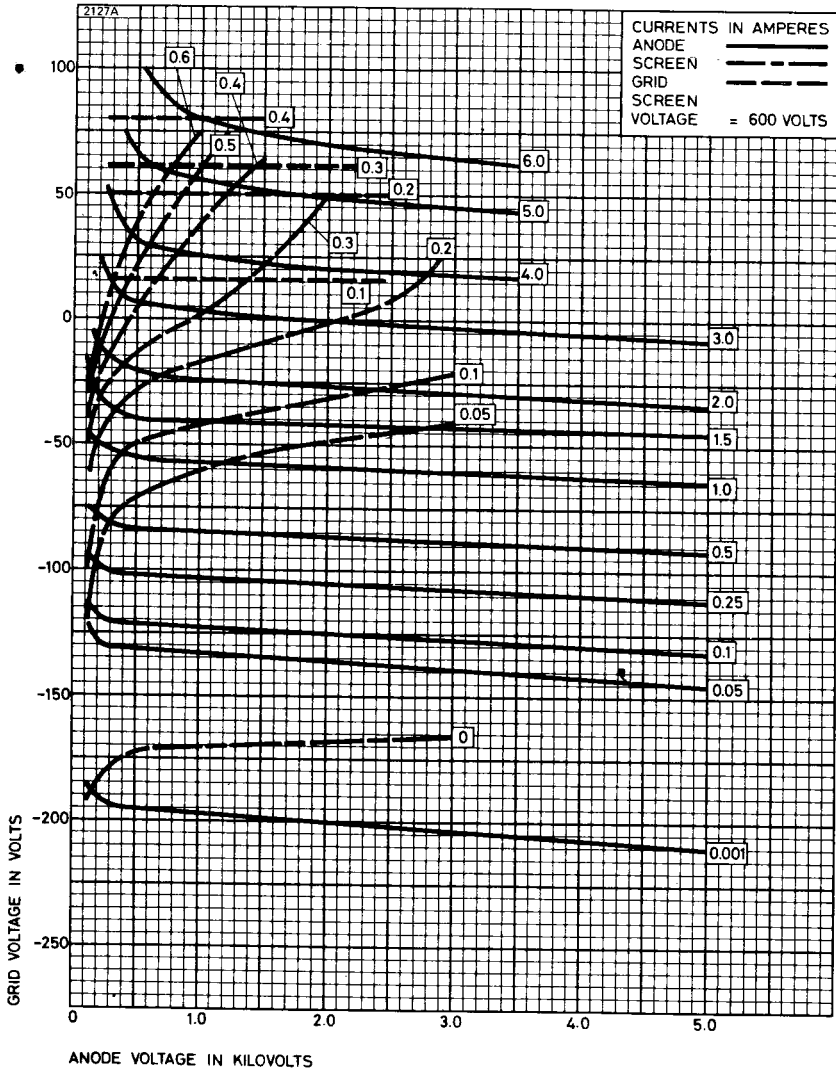

OUTLINE

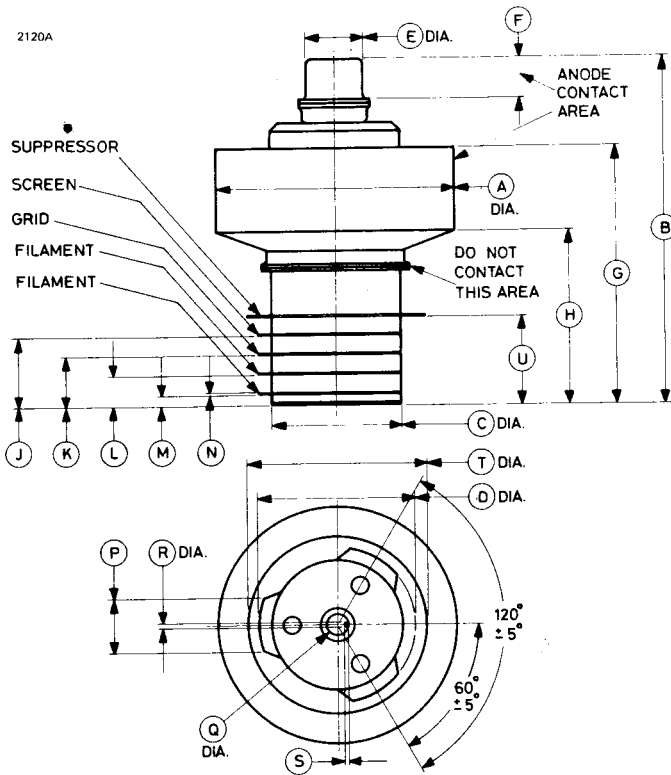

Ref	Inches	Millimetres	Ref	Inches	Millimetres
A	3.370 max	85.60 max	L	0.425 ± 0.025	10.80 ± 0.64
B	4.875 ± 0.075	123.8 ± 1.91	M	0.155 ± 0.015	3.94 ± 0.38
C	1.885 ± 0.015	47.88 ± 0.38	N	0.025 ± 0.005	0.64 ± 0.13
D	2.275 ± 0.025	57.79 ± 0.64	P	0.750 ± 0.050	19.05 ± 1.27
E	0.812 ± 0.005	20.62 ± 0.13	Q	0.320 ± 0.006	8.13 ± 0.15
F	0.500 ± 0.030	12.70 ± 0.76	R	0.065 ± 0.008	1.65 ± 0.20
G	3.630 ± 0.100	92.20 ± 2.54	S	0.033 ± 0.010	0.84 ± 0.25
H	2.435 ± 0.100	61.85 ± 2.54	T	2.531 max	64.29 max
J	0.975 ± 0.025	24.77 ± 0.64	U	1.250 ± 0.025	31.75 ± 0.64
K	0.700 ± 0.025	17.78 ± 0.64			

Millimetre dimensions have been derived from inches.



GENERAL SECTION

**TETRODES
PENTODE**



MEDIUM POWER TETRODES



HIGH POWER TETRODES



POWER PENTODE

