



BR1160

R.F. POWER TRIODE

Service Type CV8730

The data should be read in conjunction with the Power Triode Preamble.

ABRIDGED DATA

Forced-air cooled r.f. triode for a.m., f.m. or television transmitters and for industrial applications.

Anode dissipation	5.0	kW max
Anode voltage	6.0	kV max
Operating frequency	220	MHz max
Output power:		
class B audio, per valve	6.65	kW
class C telegraphy, f.m. telephony	6.9	kW
class C television, per valve	4.5	kW
class C industrial oscillator	6.5	kW



GENERAL

Electrical

Filament	thoriated tungsten
Filament voltage (see note 1)	12.6 V
Filament current	33 A
Peak usable cathode current	8.5 A
Amplification factor ($V_a = 4.0kV, I_a = 1.0A$)	32
Mutual conductance ($V_a = 4.0kV, I_a = 1.0A$)	17 mA/V
Inter-electrode capacitances:	
grid to anode	11 pF
grid to filament	16 pF
anode to filament	0.3 pF

Mechanical

Overall length (excluding flexible leads)	195mm (7.680 inches) max
Overall diameter	119mm (4.685 inches) max
Net weight	7½ pounds (3.4kg) approx
Mounting position	vertical, either way up

COOLING

Anode

The air cooling requirements for BR1160 are given in the following table. The air flow should be delivered immediately before and during the application of any voltages.

Anode dissipation (kW)	Height above sea level (m)	Inlet temperature (max) (°C)	Rate of flow of air (min) (m ³ /min)	Pressure drop (mm water)
1.0	0	35	3.0	8.0
1.0	0	45	3.1	8.0
1.0	1500	35	3.7	9.0
1.0	3000	25	4.1	10
3.0	0	35	5.2	23
3.0	0	45	6.1	29
3.0	1500	35	6.2	26
3.0	3000	25	6.6	26
5.0	0	35	9.2	68
5.0	0	45	10.7	90
5.0	1500	35	11.2	81
5.0	3000	25	11.6	79

Filament and Grid Seals

It may be necessary to direct a flow of air on to the filament and grid seals in order to maintain their temperatures within the following limits.

Temperature of filament seals	220	°C max
Temperature of grid seal	180	°C max

Anode Seal

The anode seal temperature must not exceed 180°C.

AUDIO FREQUENCY POWER AMPLIFIER OR MODULATOR (Class B)

MAXIMUM RATINGS (Absolute values)

Anode voltage	6.0	kV max
Anode current	1.5	A max
Anode input power	9.0	kW max
Anode dissipation	5.0	kW max
Grid dissipation	120	W max
Grid circuit resistance	15	k Ω max
Cathode current (peak)	5.7	A max

TYPICAL OPERATING CONDITIONS (Class B, 2 valves)

Anode voltage	3.0	3.5	4.0	kV
Grid voltage	-90	-100	-112	V
Peak a.f. grid drive voltage (per valve)	285	310	318	V
Anode current (zero signal)	2 x 65	2 x 75	2 x 100	mA
Anode current (maximum signal)	2 x 0.80	2 x 0.95	2 x 0.94	A
Grid current (maximum signal)	2 x 0.20	2 x 0.18	2 x 0.19	A
Effective load (anode to anode)	4.4	4.2	4.9	k Ω
Nominal driving power (maximum signal)	2 x 52	2 x 50	2 x 54	W
Anode dissipation	2 x 0.75	2 x 1.0	2 x 1.1	kW
Output power (maximum signal)	3.3	4.6	5.3	kW
Efficiency	69	70	71	%
Total distortion	3.3	2.9	2.6	%
Anode voltage	4.5	5.0	6.0	kV
Grid voltage	-125	-138	-165	V
Peak a.f. grid drive voltage (per valve)	327	330	455	V
Anode current (zero signal)	2 x 100	2 x 110	2 x 125	mA
Anode current (maximum signal)	2 x 0.92	2 x 0.91	2 x 1.50	A
Grid current (maximum signal)	2 x 0.19	2 x 0.14	2 x 0.28	A
Effective load (anode to anode)	6.1	6.4	4.9	k Ω
Nominal driving power (maximum signal)	2 x 27	2 x 42	2 x 115	W
Anode dissipation	2 x 1.15	2 x 1.25	2 x 2.35	kW
Output power (maximum signal)	6.0	6.6	13.3	kW
Efficiency	72	73	74	%
Total distortion	3.7	3.3	4.3	%

RADIO FREQUENCY POWER AMPLIFIER

(Class B telephony, carrier conditions per valve for use with a maximum modulation factor of 1.0)

MAXIMUM RATINGS (Absolute values)

Anode voltage	6.0	kV max
Anode current	1.1	A max
Anode input power	6.6	kW max
Anode dissipation	5.0	kW max
Grid dissipation	120	W max
Cathode current (peak)	4.6	A max

TYPICAL OPERATING CONDITIONS (frequency 75MHz)

Anode voltage	5.0	6.0	kV
Grid voltage	-145	-180	V
Peak r.f. grid drive voltage	225	250	V
Anode current	900	990	mA
Grid current (100% modulation)	320	300	mA
Driving power (100% modulation)	160	170	W
Anode dissipation	3.0	4.0	kW
Output power	1.45	1.90	kW
Efficiency	32	32	%

RADIO FREQUENCY POWER AMPLIFIER

(Class C telegraphy, key down conditions, or F.M. telephony, per valve)

MAXIMUM RATINGS (Absolute values)

Anode voltage	6.0	kV max
Anode current	1.5	A max
Anode input power	9.0	kW max
Anode dissipation	5.0	kW max
Grid voltage (negative value)	1.0	kV max
Grid current	0.35	A max
Grid dissipation	120	W max
Cathode current (peak)	8.5	A max

TYPICAL OPERATING CONDITIONS

(Grounded Cathode)

Frequency	75	75	75	110	MHz
Anode voltage	4.0	5.0	6.0	5.0	kV
Grid voltage	-200	-300	-400	-300	V
Peak r.f. grid drive voltage	500	640	740	640	V
Anode current	1.37	1.50	1.50	1.25	A
Grid current	350	330	310	300	mA
Nominal driving power	190	240	275	250	W
Anode dissipation	1.5	1.9	2.1	1.45	kW
Output power	4.0	5.6	6.9	4.8	kW
Efficiency	73	75	76.5	70	%

TYPICAL OPERATING CONDITIONS

(Grounded Grid, 2 valves)

Frequency	75	110	110	220	MHz
Anode voltage	6.0	4.0	5.0	4.0	kV
Filament-grid voltage	400	200	300	200	V
Peak r.f. drive voltage, filament to filament	1480	1000	1280	900	V
Anode current	2 x 1.5	2 x 1.37	2 x 1.5	2 x 1.25	A
Grid current	2 x 310	2 x 350	2 x 330	2 x 220	mA
Nominal driving power	2 x 1190	2 x 705	2 x 965	2 x 395	W
Anode dissipation	2 x 2.1	2 x 1.7	2 x 2.2	2 x 2.5	kW
Output power (see note 2)	15.6	8.6	12	5.6	kW
Efficiency	77	69	71	50	%

ANODE MODULATED R.F. POWER AMPLIFIER

(Class C telephony, carrier conditions per valve for use with a maximum modulation factor of 1.0)

MAXIMUM RATINGS (Absolute values)

Anode voltage	5.0	kV max
Anode current	1.3	A max
Anode input power	6.5	kW max
Anode dissipation	3.4	kW max
Grid voltage (negative value)	1.0	kV max
Grid current	0.35	A max
Grid dissipation	120	W max
Cathode current (peak)	5.7	A max

TYPICAL OPERATING CONDITIONS

Frequency	75	75	75	MHz
Anode voltage	3.0	3.5	4.0	kV
Grid voltage	-250	-300	-300	V
Peak r.f. grid drive voltage	510	600	600	V
Anode current	1.0	1.2	1.2	A
Grid current	0.3	0.3	0.3	A
Nominal driving power	170	205	205	W
Anode dissipation	0.8	1.2	1.3	kW
Output power	2.2	3.0	3.5	kW
Efficiency	73	71.5	73	%

Frequency	75	75	110	MHz
Anode voltage	4.5	5.0	4.0	kV
Grid voltage	-350	-400	-350	V
Peak r.f. grid drive voltage	650	690	600	V
Anode current	1.2	1.2	0.93	A
Grid current	0.3	0.3	0.24	A
Nominal driving power	230	205	130	W
Anode dissipation	1.3	1.3	0.92	kW
Output power	4.1	4.7	2.8	kW
Efficiency	76	78	75	%

CLASS C TELEVISION SERVICE, GRID-MODULATED

MAXIMUM RATINGS (Absolute values)

Anode voltage:		
up to 75MHz	5.0	kV max
up to 220MHz	4.0	kV max
Anode current	1.9	A max
Anode input power	9.5	kW max
Anode dissipation (sync. level)	5.0	kW max
Grid voltage (negative value) (sync. level)	1.0	kV max
Grid current	0.25	A max
Grid dissipation (sync. level)	120	W max
Cathode current (peak)	10	A max



TYPICAL OPERATING CONDITIONS

(Negative modulation, positive synchronisation) (2 valves)

Frequency	48 to 75	170 to 220	MHz
Anode voltage	5.0	4.0	kV
Grid voltage:			
peak sync.	-200	-250	V
black level	-300	-225	V
white level	-550	-500	V
Peak r.f. grid to grid voltage			
(sync. level)	1.0	1.0	kV
Anode current:			
peak sync.	2 x 1.9	2 x 1.6	A
black level	2 x 1.3	2 x 1.3	A
Grid current:			
peak sync.	2 x 0.250	2 x 0.20	A
black level	2 x 0.175	2 x 0.11	A
Nominal driving power (sync. level)	2 x 250	2 x 400	W
Output power (sync. level)	9.0	6.0	kW
Power into load (sync. level)			
(see note 3)	6.3	4.2	kW
Bandwidth (see note 4):			
to -3db points	8.00	10	MHz
to -1.5db points	5.25	6.5	MHz

TYPICAL OPERATING CONDITIONS

(Positive modulation, negative synchronisation) (2 valves)

Frequency	48 to 75	MHz
Anode voltage	5.0	kV
Grid voltage:•		
white level	-200	V
black level	-460	V
peak sync.	-580	V
Peak r.f. grid to grid voltage (white level)	1.0	kV
Anode current:		
white level	2 x 1.9	A
black level	2 x 0.4	A
Grid current:		
white level	2 x 250	mA
black level	0	mA
Nominal driving power (white level)	2 x 250	W
Output power (white level)	9.0	kW
Power into load (white level) (see note 3)	6.3	kW
Bandwidth (see note 4):		
to -3db points	8.0	MHz
to -1.5db points	5.25	MHz

RADIO FREQUENCY OSCILLATOR FOR INDUSTRIAL SERVICE

(Class C, anode supply from unfiltered two-phase half-wave rectifier)

MAXIMUM RATINGS (Absolute values)

Anode voltage	5.4	kV max
Anode current	1.35	A max
Anode input power	9.0	kW max
Anode dissipation	5.0	kW max
Grid voltage (negative value)	900	V max
Grid current	0.31	A max
Grid dissipation	120	W max

TYPICAL OPERATING CONDITIONS

Output voltage (r.m.s.) from transformer	5.1	6.0	kV
Anode voltage	4.6	5.4	kV
Anode current	1.15	1.35	A
Grid current	0.27	0.31	A
Anode dissipation	1.84	2.3	kW
Grid resistor	1.1	1.3	kΩ
Nominal driving power	160	210	W
Output power	4.5	6.5	kW
Efficiency	70	72	%

RADIO FREQUENCY OSCILLATOR FOR INDUSTRIAL SERVICE

(Class C, anode supply unrectified a.c.)

MAXIMUM RATINGS (Absolute values)

Output voltage (r.m.s.) from transformer	6.8	kV max
Anode current	0.8	A max
Anode input power	9.0	kW max
Anode dissipation	5.0	kW max
Grid voltage (negative value)	640	V max
Grid current	190	mA max
Grid dissipation	120	W max
Operating frequency	75	MHz max

TYPICAL OPERATING CONDITIONS

Output voltage (r.m.s.) from transformer	5.9	6.8	kV
Grid voltage	-173	-200	V
from grid resistor	1050	1050	Ω
Anode current	0.7	0.8	A
Grid current (approx)	165	190	mA
Anode dissipation	1.24	1.5	kW
Output power	3.36	4.55	kW
Efficiency	73	75	%

NOTES

1. The valve must be operated at the stated filament voltage. Fluctuation in filament voltage must not exceed +5% or -10%. The centre-tap lead may be used for the anode current return but must not be used for the filament current supply. At frequencies above 30MHz, all three filament leads should be interconnected with suitable capacitors.
2. This includes the power transferred from the drive circuit.
3. Assuming circuit transfer efficiency of 70%.
4. For a bandwidth based on one inductor-capacitor circuit.

TYPICAL ANODE CHARACTERISTICS

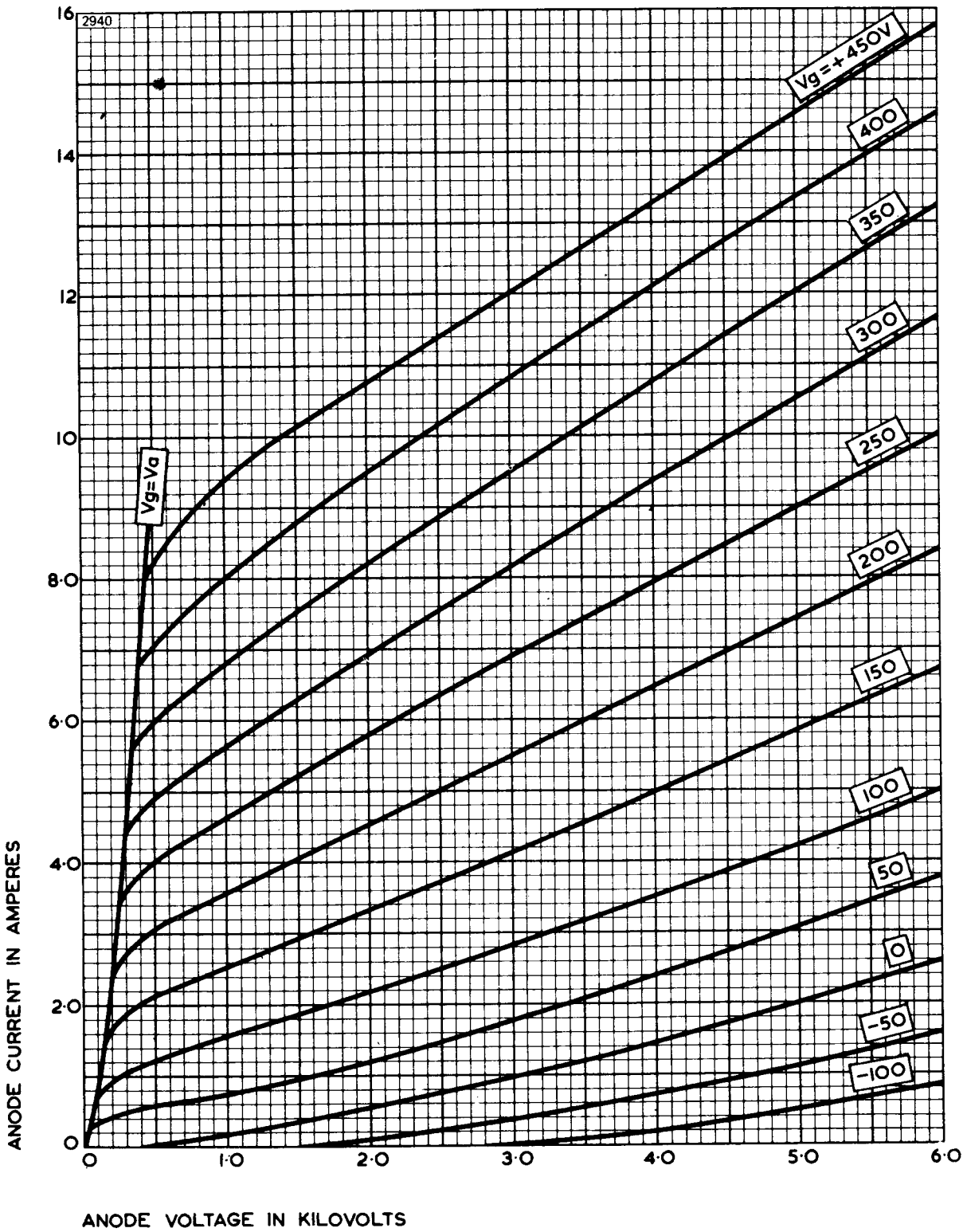

TYPICAL GRID CHARACTERISTICS

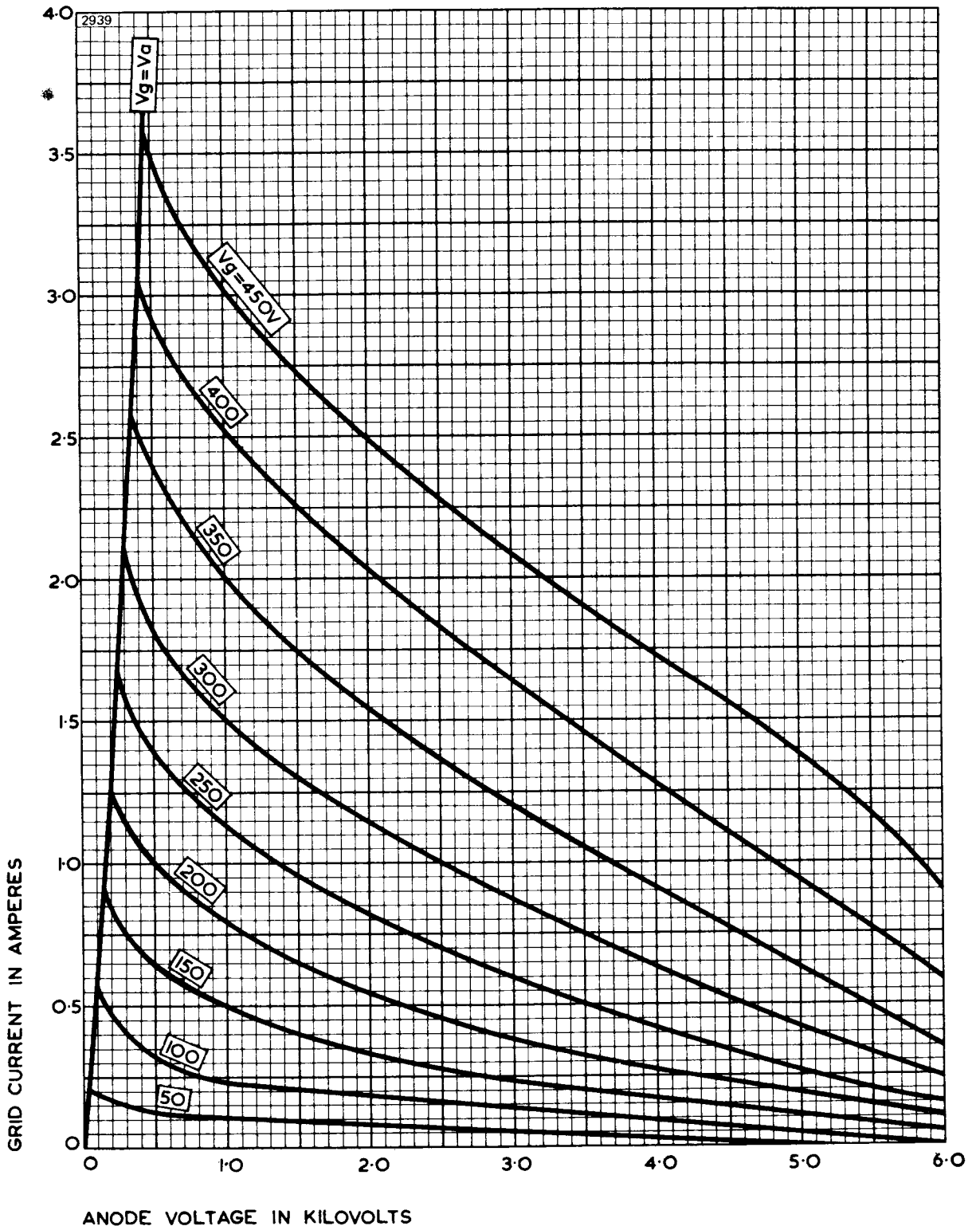

TYPICAL ANODE CURRENT – GRID VOLTAGE CHARACTERISTICS

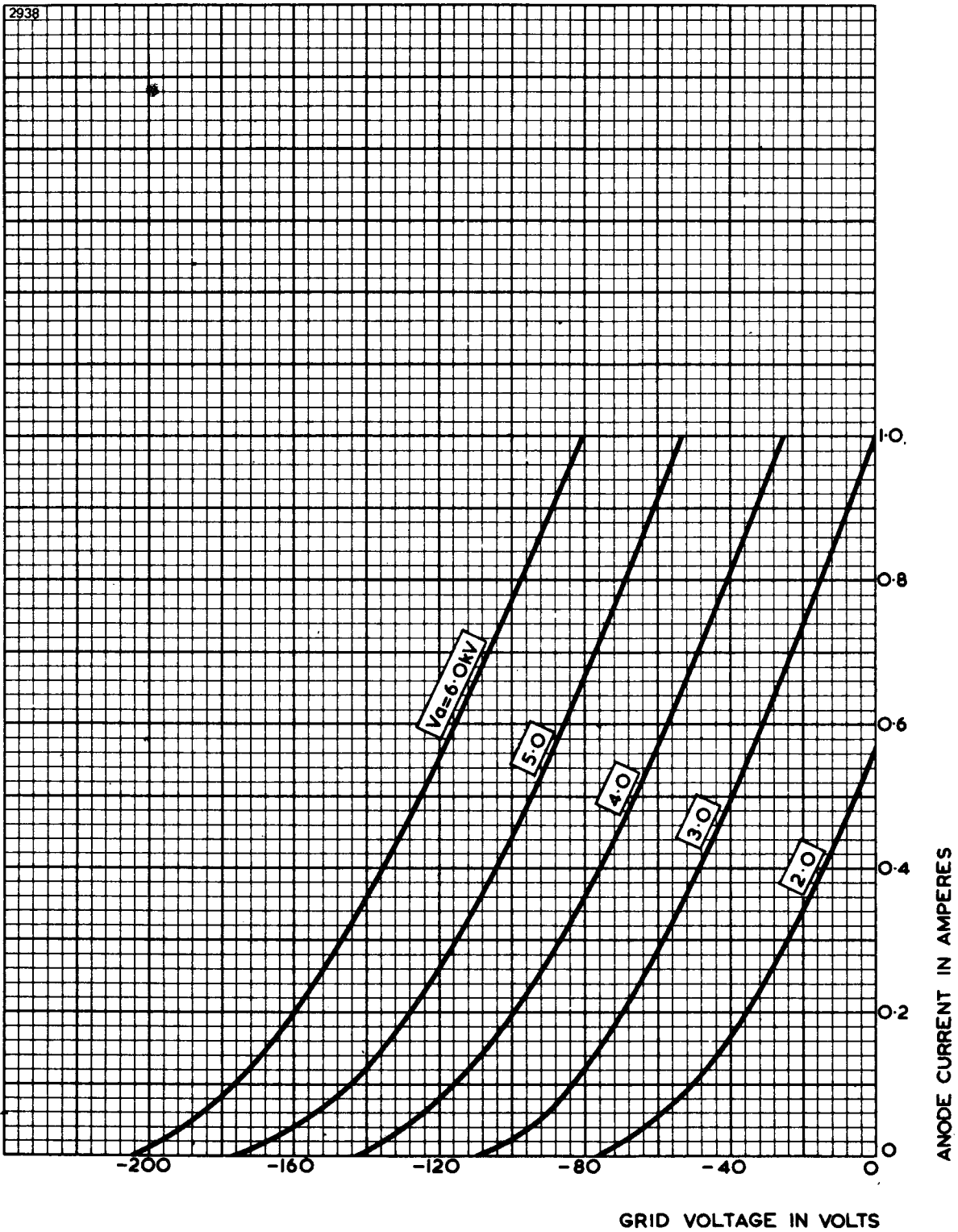

TYPICAL STRAPPED CHARACTERISTICS

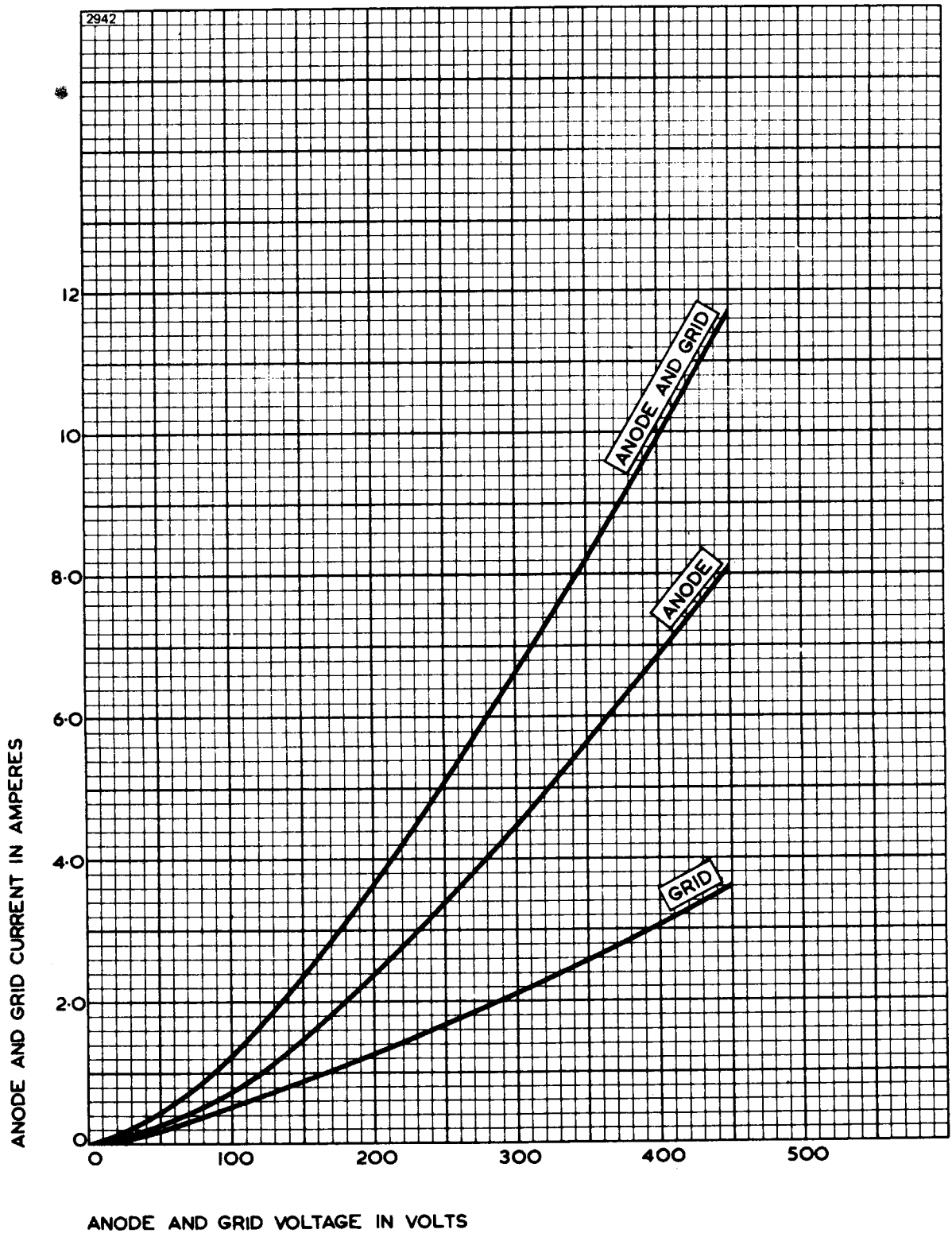

TYPICAL CONSTANT CURRENT CHARACTERISTICS

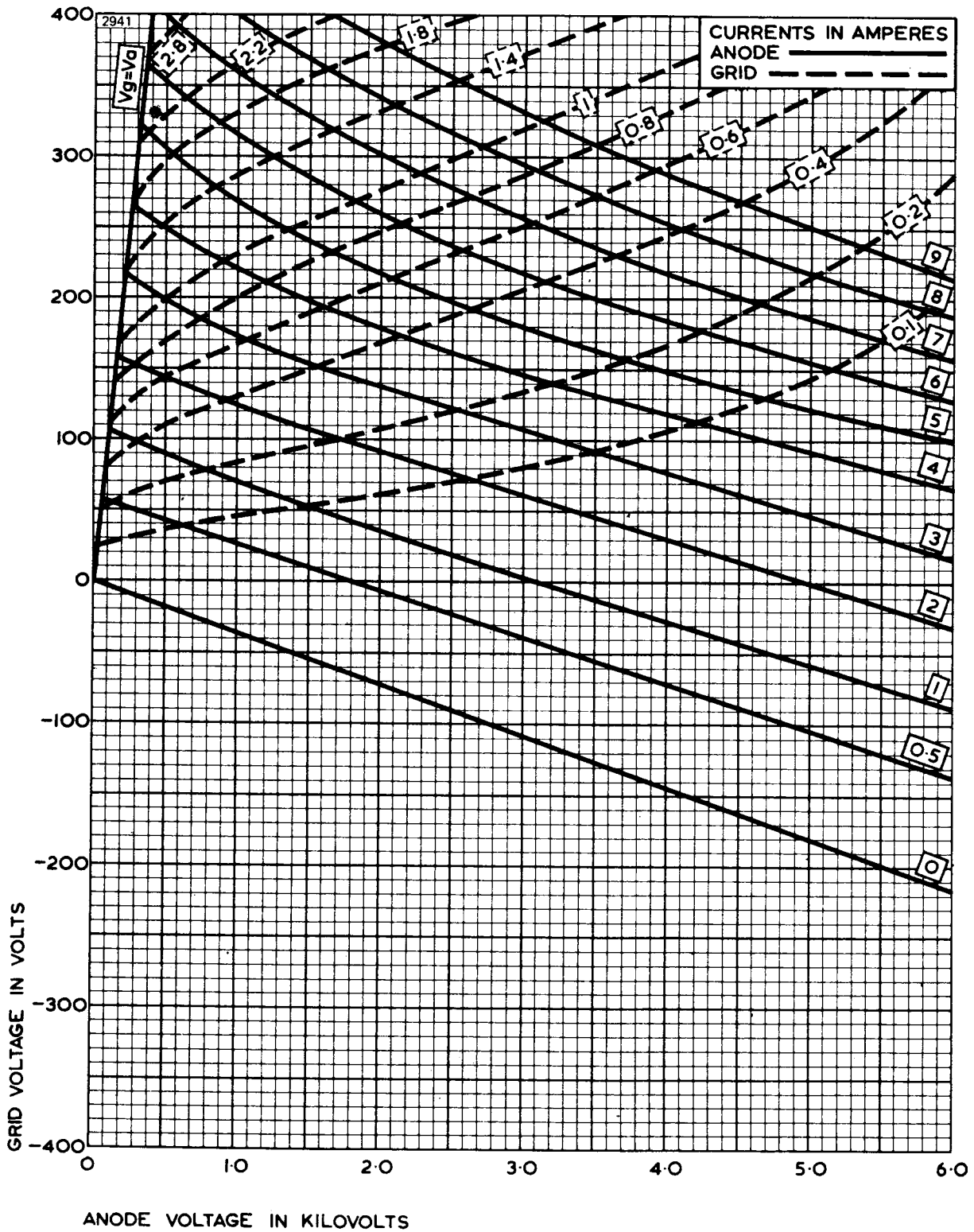

OUTLINE

2955

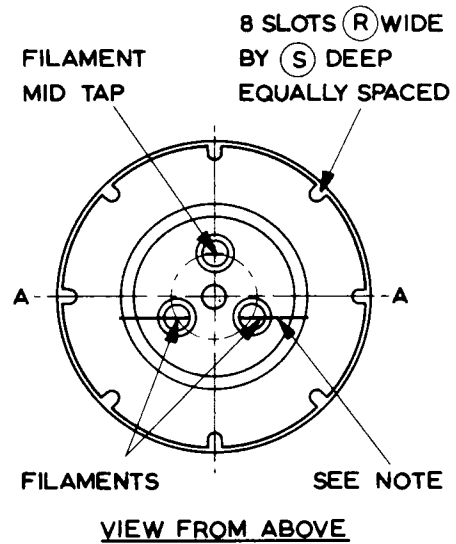
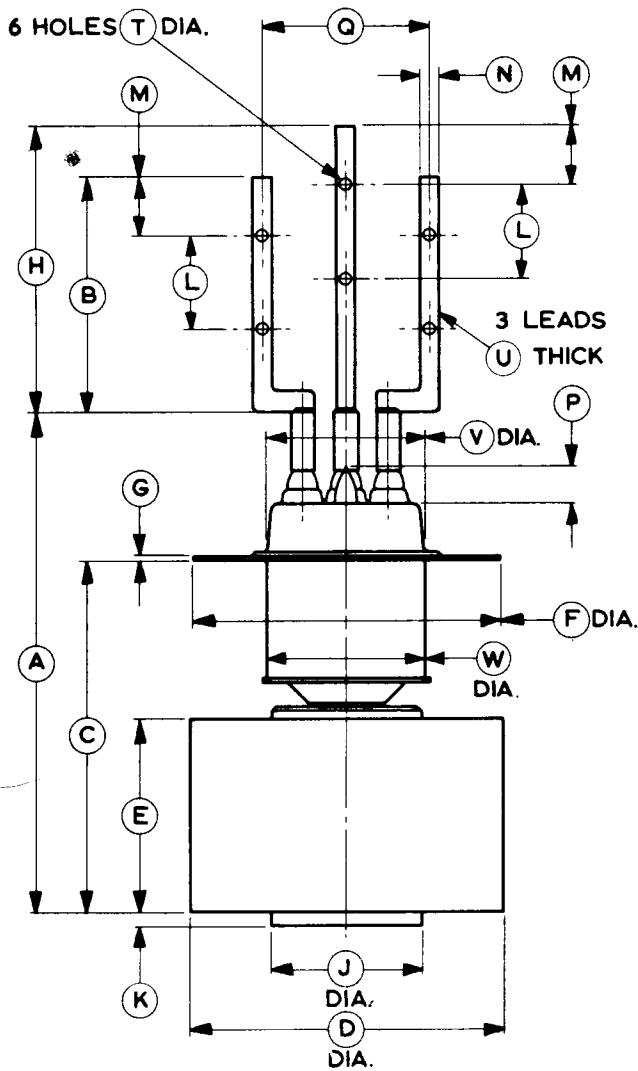

Ref	Millimetres	Inches
A	188.0 ± 2.0	7.402 ± 0.079
B	89.0 ± 2.0	3.504 ± 0.079
C	133.5 ± 3.5	5.256 ± 0.138
D	117.5 ± 1.5	4.626 ± 0.059
E	73.0 max	2.874 max
F	116.0 ± 0.5	4.567 ± 0.020
G	1.50 ± 0.20	0.059 ± 0.008
H	108.0 ± 2.0	4.252 ± 0.079
J	57.0 max	2.244 max
K	4.50 ± 0.50	0.177 ± 0.020
L	35.0 ± 2.0	1.378 ± 0.079

Ref	Millimetres	Inches
M	22.0 ± 2.0	0.866 ± 0.079
N	8.00 ± 0.50	0.315 ± 0.020
P	23.0 max	0.906 max
Q	62.5 ± 2.5	2.461 ± 0.098
R	4.62 ± 0.1	0.182 ± 0.004
S	5.20 ± 0.20	0.205 ± 0.008
T	3.60 ± 0.10	0.142 ± 0.004
U	4 x 0.25	4 x 0.010
V	59.0 max	2.323 max
W	64.0 max	2.520 max

Inch dimensions have been derived from millimetres.

Note Plane of filament leads will be parallel to A-A to within 3½°