

SONY®

STEREO TAPECORDER TC-350

OWNER'S INSTRUCTION MANUAL

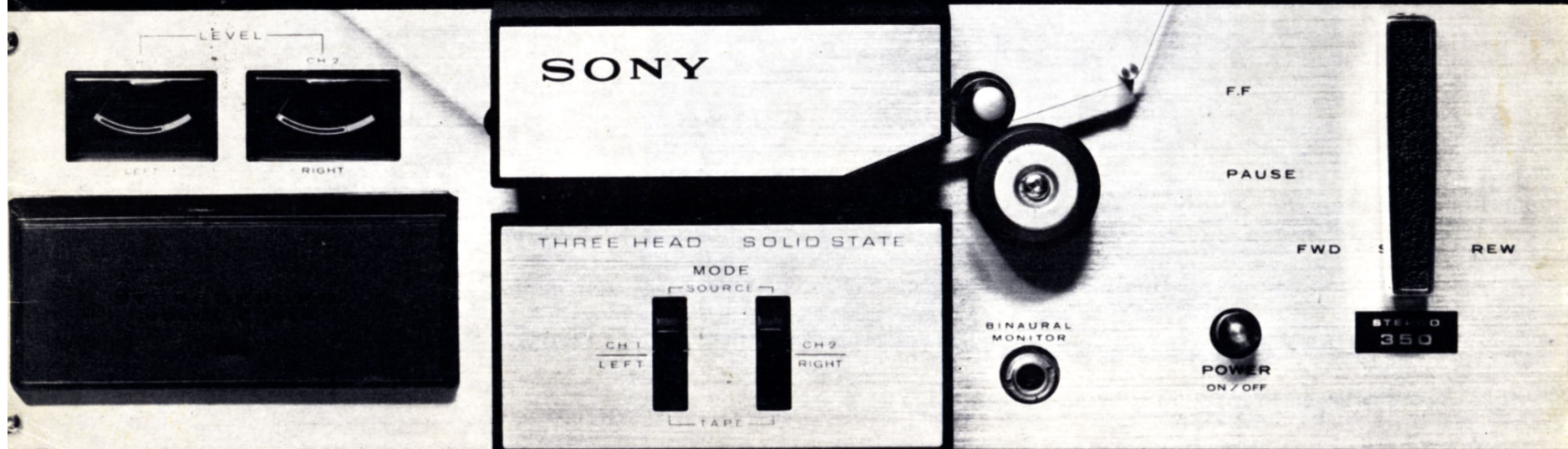

Your new SONY Model TC-350 stereo tape recorder is a 4-track solid state instrument of superior performance, built to exacting SONY tape recorder standards. Providing outstanding versatility, ease of operation with vertical or horizontal operating position and the professional features of sound-on-sound and tape/source monitoring. The 3-head TC-350 will enhance your hi-fi sound system.

Read the information contained in this manual carefully before operating the recorder

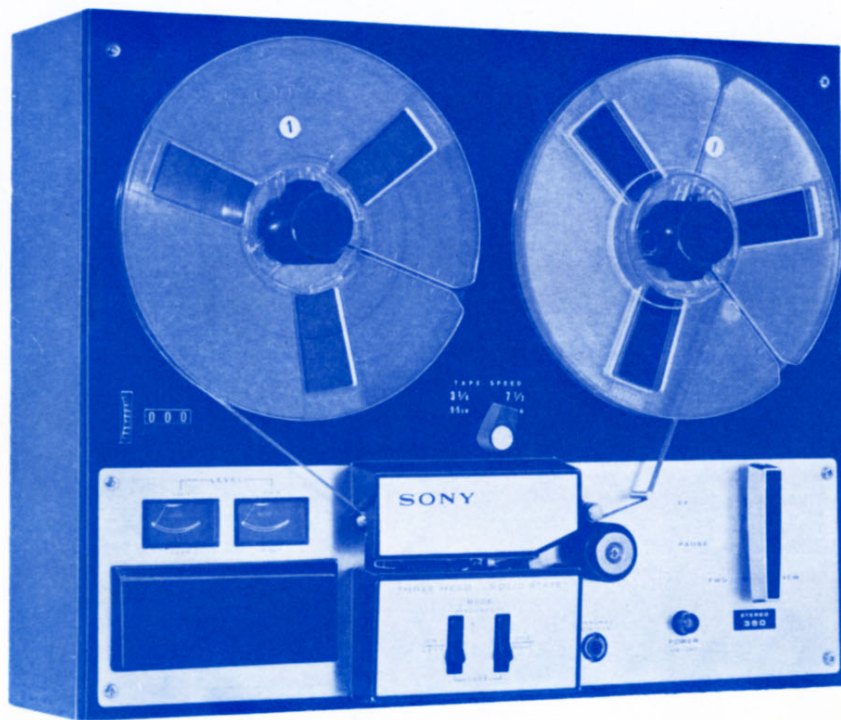

Save this manual for future reference.

Technical Specifications

Power requirements: 50 watts, 100, 110, 117, 125, 220 or 240 volts, 50/60 cycles AC

Tape width: ½ inch

Reels: 7 inches or smaller

Tape speed: Instantaneous selection 7½ ips. (19 cm/sec.) or 3¾ ips. (9.5 cm/sec.) with automatic equalization change

Recording system: 4-track stereophonic or monophonic

Frequency response: 30-20,000 c/s at 7½ ips. (19 cm/sec.) ±3 db
50-15,000 c/s at 7½ ips. (19 cm/sec.)
30-14,000 c/s at 3¾ ips. (9.5 cm/sec.)

Signal-to-Noise ratio: tape speed peak record level to unweighted noise

7½ ips. (19 cm/sec.)	50 db or better
3¾ ips. (9.5 cm/sec.)	50 db or better

* The peak record level is defined as that level at which the overall (input to output on 'line output jack') total RMS harmonic distortion does not exceed 3% when measured on a 400 cycle tone. Noise is measured by playing an erased portion of the tape, on which a signal of peak recording level was present prior to erasure. This will produce the overall figure of noise, including the bias and erase noise, as well as record and playback amplifier noise.

Flutter and wow: tape speed

7½ ips. (19 cm/sec.)	less than 0.17% RMS
3¾ ips. (9.5 cm/sec.)	less than 0.25% RMS

* The flutter and wow measurements include all components between 0.5 and 250 cycles.

Harmonic distortion: less than 3% at 0 db line output

Level indication: two VU meters

record: NAB standard

playback: calibrated to 0 db at 0 db line output

Recording time:

		4-track stereo	4-track monophonic
1,200' tape	7½ ips. (19 cm/sec.)	1 hr.	2 hrs.
	3¾ ips. (9.5 cm/sec.)	2 hrs.	4 hrs.
1,800' tape	7½ ips. (19 cm/sec.)	1 hr. 30 min.	3 hrs.
	3¾ ips. (9.5 cm/sec.)	3 hrs.	6 hrs.

Fast forward and rewind time:

within 4 min. (1,200' tape)

Inputs: Microphone inputs

Sensitivity: -72 db (0.19 mV)

Impedance: low (will accommodate any microphone from 250~1K ohm impedance)

Auxiliary inputs

Sensitivity: -22 db (0.06 V)

Impedance: approx. 100K ohms

Integrated record/playback connector

Sensitivity: -42 db (6.15 mV)

Impedance: approx. 100K ohms

Outputs: Line outputs
 Output level: 0 db (0.775 V)
 Impedance: optimum load impedance 100K ohms
 Binaural monitor jack
 Output level: -1 db (0.692 V)
 Impedance: accommodates 10K ohm headset
 Integrated record/playback connector
 Output level: 0 db (0.775 V)
 Impedance: optimum load impedance 500K ohms

Heads: Recording head RP 30-2902
 Playback head PP 30-4202 N
 Erase head EF 18-2902 H

Transistors: 2 SC 402 × 18
 2 SB 381 × 2
 2 SC 291 × 1

Diodes: 1 T 22 A × 2
 5 G-D × 2

Dimensions: 15½ (w) × 6¾ (h) × 13 (d)''
 (400 × 160 × 320 mm)

Weight: 17 lb 3 oz
 (8 kg)

Table of Contents

Diagram of controls and connectors 3
 Operation of controls 5
 input and output connectors 8
 How to connect the recorder to
 an integrated amplifier.....11
 Threading tape12
 Playing tapes13
 To play back 4-track stereo tape
 To play back 4-track monophonic tape
 Recording14
 4-track stereo recording
 To monitor while recording
 4-track monophonic recording
 Erasing tape16
 Splicing tape16
 Sound-on-sound recording17
 Tape teaching.....18
 How to mount Model TC-350.....20
 Mounting dimensions.....21
 Adaptation to the local power line.....22
 Maintenance23
 Cleaning heads
 Demagnetizing heads
 Lubrication chart
 Schematic diagram25
 Recommended accessories26

Diagram of Controls and Connectors

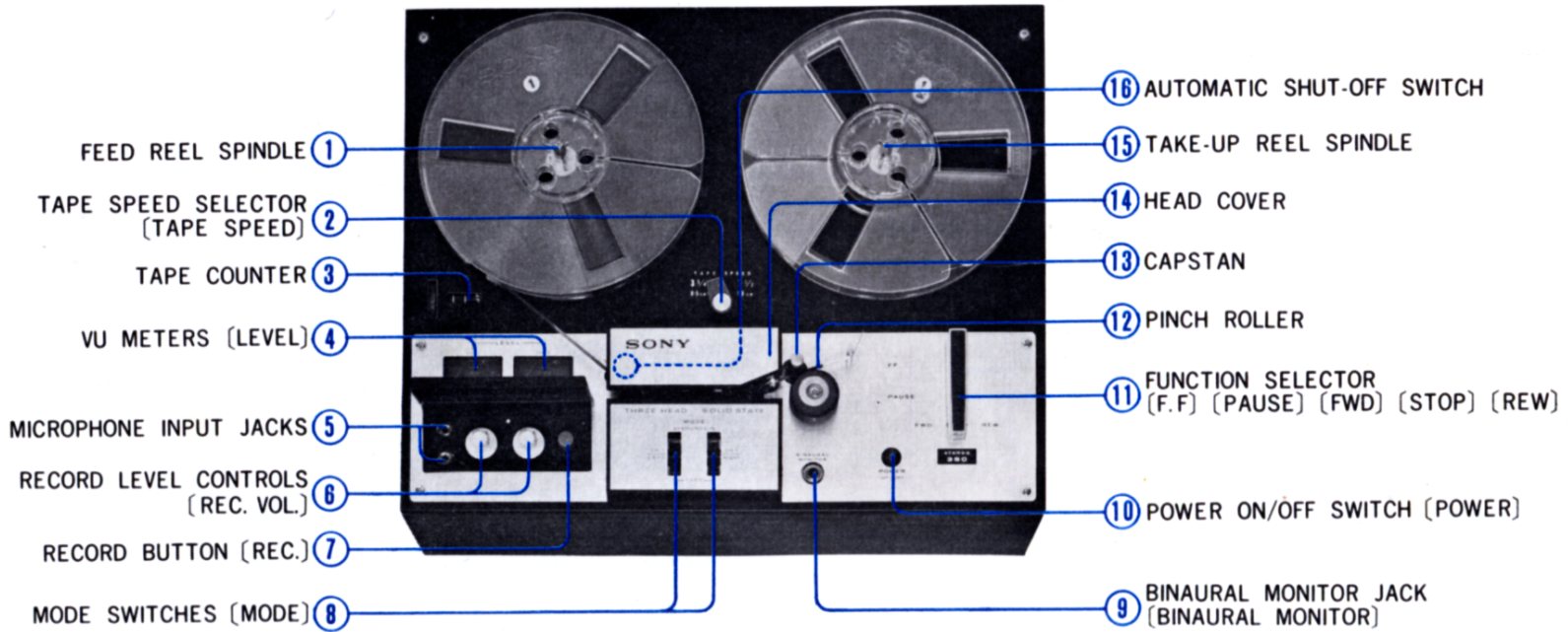

Refer to OPERATION of CONTROLS on page 5 ~ 8.

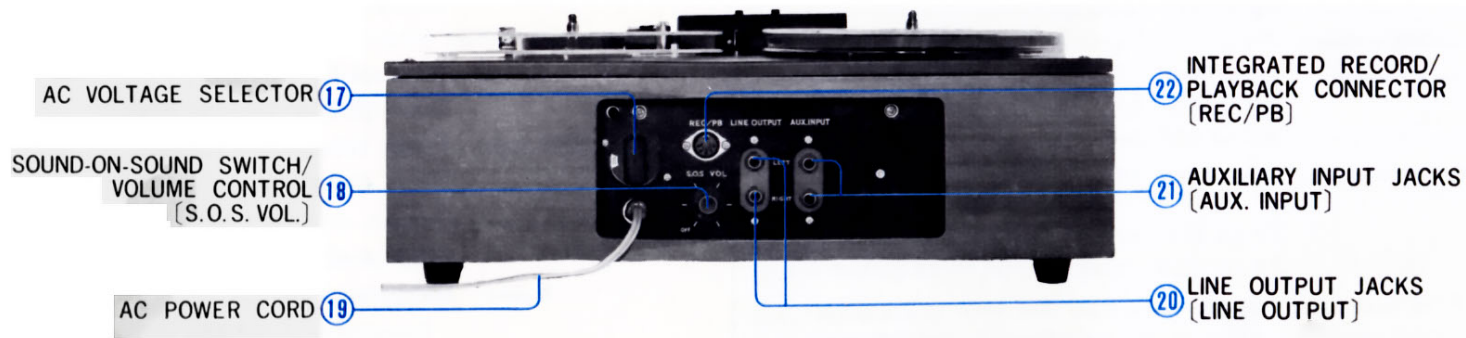

Your SONY tape recorder can be set for operating on AC voltage of 100, 110, 117, 125, 220 or 240 volts, and line frequency of either 50 or 60 cycles.

Before connecting the recorder to the power line, be sure to check whether the recorder is set for operating AC voltage and line frequency identical to the local power supply in your area.

Simple instructions for this adjustment are contained on page 22, ADAPTATION TO THE LOCAL POWER LINE.

Refer to INPUT AND OUTPUT CONNECTORS on page 8 ~ 10.

Operation of Controls

① FEED REEL SPINDLE

② TAPE SPEED SELECTOR [TAPE SPEED]

Selects tape speed of either 7½ ips. (19 cm/sec.) when better sound quality is desired, or 3½ ips. (9.5 cm/sec.) when longer recording time is desired.

To change from 3½ ips. (9.5 cm/sec.) to 7½ ips. (19 cm/sec.), press down on the selector knob and turn clockwise to 7½ ips. (19 cm/sec.). To change from 7½ ips. (19 cm/sec.) to 3½ ips. (9.5 cm/sec.), turn the knob counterclockwise and allow the knob to rise.

③ TAPE COUNTER

Indicates the amount of tape used in either record or playback. To reset the tape counter, rotate reset wheel, located to the left of numbers, upward until three zeros [000] appear in the window.

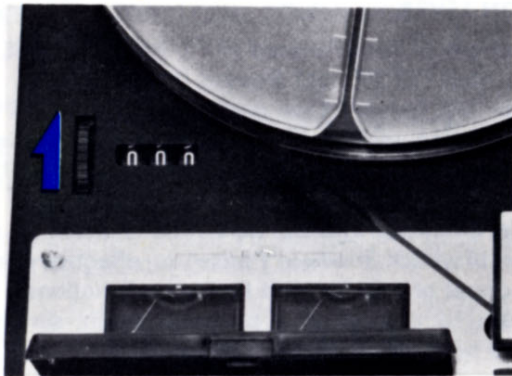

④ VU METERS

Indicates the level of signal being recorded or playback according to the position of the MODE SWITCHES ⑧.

When the MODE SWITCH is set in [SOURCE] position: these meters are calibrated to NAB standard allowing the maximum recording level without distortion.

For best recording results, the RECORD LEVEL CONTROLS ⑥ should be adjusted so that the deflection of the VU METER needle does not continuously remain in the red zone. It is normal for occasional transient peaks to deflect the needle into the red zone.

When the MODE SWITCH is set in [TAPE] position: the tape being recorded can be monitored while the recorder is in RECORD mode. For playback these meters are calibrated so that the needle points to the boundary of red and black zones when the line output level, is approx. 0 db (0.775 V).

⑤ MICROPHONE INPUT JACKS [MIC]

See page 8, INPUT AND OUTPUT CONNECTORS.

⑥ RECORD LEVEL CONTROLS [REC. VOL.]

Controls level of signal being recorded.

The knob marked [LEFT] is for left channel (CH-1) and the knob marked [RIGHT] is for right channel (CH-2). To increase turn clockwise and to decrease turn counterclockwise. When turned fully counterclockwise to [OFF] position with a click, bias and erase currents to the respective channel are shut off, thus making possible 4-track monophonic recording.

NOTE: These controls have no effect upon playback level.

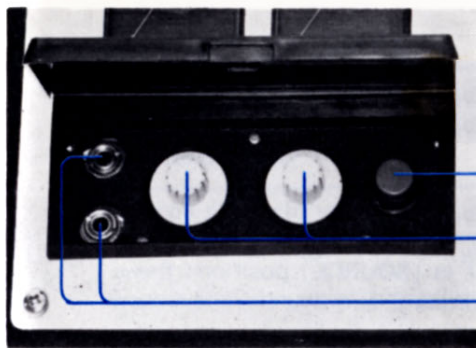

- ⑦ RECORD BUTTON [REC.]
- ⑧ RECORD LEVEL CONTROLS [REC. VOL.]
- ⑤ MICROPHONE INPUT JACKS [MIC]

⑦ RECORD BUTTON

Activates RECORD mode switch.

While pressing the button, turn the FUNCTION SELECTOR to [FWD] position; the tape motion will start and red lamps in the VU METERS will illuminate indicating that the recorder is in RECORD mode.

NOTE: When the FUNCTION SELECTOR is set to [STOP] position, the RECORD BUTTON will be released and the recorder will automatically switch from record to playback.

⑧ MODE SWITCHES [MODE]

Has two positions: [SOURCE] and [TAPE].

[SOURCE] The input program source is connected to LINE OUTPUT JACKS ⑳, output of INTEGRATED RECORD/PLAYBACK CONNECTOR ㉒ and BINAURAL MONITOR JACK ⑨.

The VU METER needle deflection shows the level of the input program source. With this feature, the recording level can be previously adjusted without pressing RECORD BUTTON.

[TAPE] For playback, set the switches to this position. The deflection of the VU METER needle shows the playback level.

For instantaneous tape monitoring while recording, set the switches to this position.

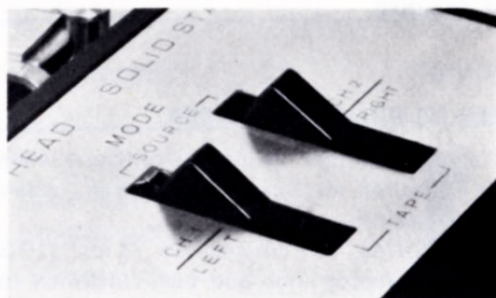

⑨ BINAURAL MONITOR JACK [BINAURAL MONITOR]

See page 8, INPUT AND OUTPUT CONNECTORS.

⑩ POWER ON/OFF SWITCH [POWER]

Press to turn the recorder ON. The button is locked and the lamp illuminates. Press again to turn OFF.

⑪ FUNCTION LEVER

Has five positions of Fast Forward [F.F], Pause [PAUSE], Forward [FWD], Stop [STOP] and Rewind [REW].

[F.F.] For fast forward tape motion.

The tape motion can be stopped by turning the FUNCTION SELECTOR to [PAUSE] or [STOP] position.

[PAUSE] To momentarily stop tape motion either in record or playback mode. 'Pause' is effective for both normal or fast forward tape speed motions. To return to recording or playback again, simply turn the selector to [FWD] position.

[FWD] To move the tape at normal tape speed for recording or playback.

NOTE: While recording if the selector is set to [STOP] position, the recorder will automatically switch from record to playback mode.

[STOP] To stop the tape motion.

Always keep the selector in [STOP] position, when the recorder is not in use.

[REW] To rewind the tape.

NOTE: a. Change from [REW] to [FWD] (or vice versa) must be made by bringing the tape to a complete stop in [STOP] position.

b. Change from [F.F] to [FWD] must be made by bringing the tape to a complete stop in [PAUSE] position.

12 PINCH ROLLER

Presses the tape against the capstan to drive the tape.

If the line frequency differs from what the recorder is adjusted for, the PINCH ROLLER, as well as capstan and the tapping of the motor capacitor terminals should be altered. See page 22, ADAPTATION TO THE LOCAL POWER LINE.

13 CAPSTAN

Drives the tape at a constant speed.

If the line frequency differs from what the recorder is adjusted for, the CAPSTAN, pinch roller and the tapping of the motor capacitor terminals should be altered. See page 22, ADAPTATION TO THE LOCAL POWER LINE.

14 HEAD COVER

Protects heads. When cleaning the heads, remove the cover by pulling it up.

15 TAKE-UP REEL SPINDLE

16 AUTOMATIC SHUT-OFF SWITCH

This switch is controlled by a wire lever located under the head cover. In [STOP] position the shut-off lever recedes into a slot to facilitate easy tape threading. After tape is threaded and the mechanism is placed in either Forward [FWD], Fast Forward [F.F] or Rewind [REW] mode, the shut-off lever contacts the tape and is held in this position.

At such time as the tape either runs out or breaks, the lever will automatically fall forward and activate a micro switch which stops tape motion; however, the internal amplifiers are still ON.

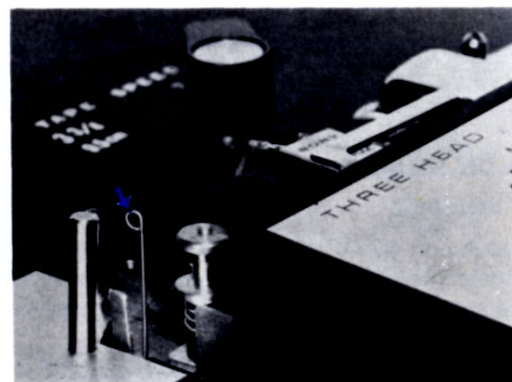

Input and Output Connectors

17 AC VOLTAGE SELECTOR

Selects the operating AC power line voltage of 100V, 110V, 117V, 125V, 220V or 240V.

Before connecting the recorder to power line, check whether the selector is correctly set for operating the local power supply voltage in your area.

To reset the selector, pull out the selector cap and firmly reinsert it to the VOLTAGE SELECTOR with the proper voltage figure appearing in the cutout of the selector cap.

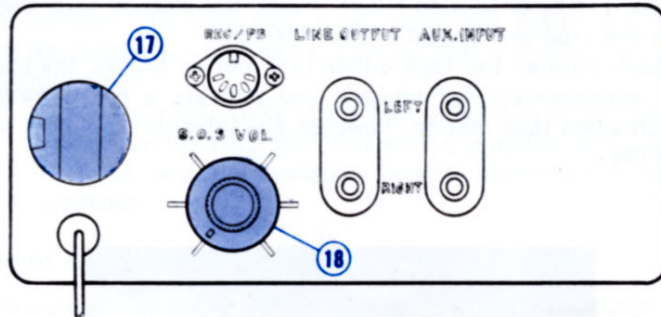

18 SOUND-ON-SOUND SWITCH/VOLUME CONTROL [S.O.S. VOL.]

Activates sound-on-sound record mode and also controls left channel (CH-1) playback level for composite recordings. For sound-on-sound recording, turn the knob clockwise from [OFF] position and adjust the volume level.

IMPORTANT: Be sure the S.O.S. SWITCH/VOLUME CONTROL is turned off when this facility is not being used.

5 MICROPHONE INPUT JACKS [MIC]

These mini jack inputs are located at the left side of the front panel and accept any high quality low impedance microphone. The low impedance SONY F-96 microphones available as optional accessories are recommended.

The jack marked [L] is for left channel (CH-1) and the jack marked [R] is for right channel (CH-2).

NOTE: When recording with a microphone, howling sounds (acoustic feedback) may occur if the microphone is too near the speakers. In this case, reduce the speaker volume or turn the speaker switch off.

These inputs can also be used with a telephone pickup SONY model TP-4S (optional), microphone mixer SONY model MX-600 (optional) for microphone and line mixing, SONY radio equipped with a recording jack.

9 BINAURAL MONITOR JACK [BINAURAL MONITOR]

A standard binaural phone jack is located at the center of the front panel. This output connects to any high impedance stereo headset which is equipped with a standard binaural phone plug. It enables stereo headset monitoring of either 'source' or 'tape' when used in conjunction with the MODE SWITCHES 8.

Ideal headset is the SONY model DR-3C, which is available as an optional accessory.

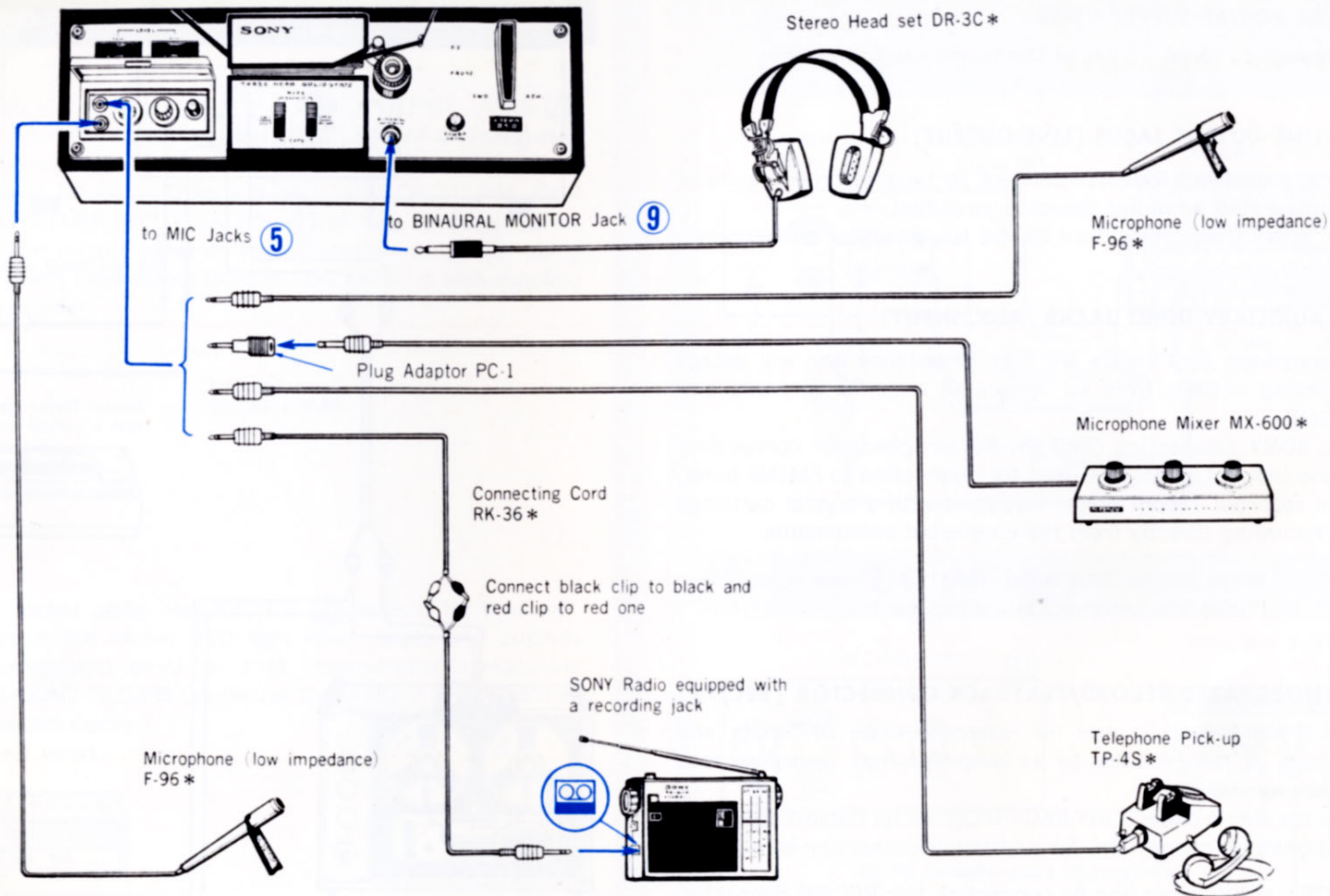

Accessories marked * are available separately

19 AC POWER SUPPLY CORD

Connects to an AC outlet of the household power line.

20 LINE OUTPUT JACKS [LINE OUTPUT]

These phono jack outputs connect to tape recorder inputs of an integrated amplifier (pre-amp/amplifier). Use SONY Connecting Cord RK-56 (supplied) for connection.

21 AUXILIARY INPUT JACKS [AUX. INPUT]

These phono jack inputs are high impedance and will accept recording outputs from an integrated amplifier (pre-amp/amplifier).

Use SONY Connecting Cord RK-56 (supplied) for connection. These inputs can also be used for connection to FM/AM tuner, tape recorder, record player equipped with a crystal cartridge for recording directly from the connected components.

NOTE: When the MICROPHONE INPUTS 5 are used, these inputs are automatically disconnected.

22 INTEGRATED RECORD/PLAYBACK CONNECTOR [REC/PB]

The 5-pin socket is used for interconnection of inputs and outputs of the recorder to an amplifier that incorporates a matching socket.

Use the single cable SONY REC/PB Connector Cable model RC-2 (optional) for connection. No additional connection is required.

NOTE: While recording by connecting this REC/PB connector, the outputs of this connector are disconnected

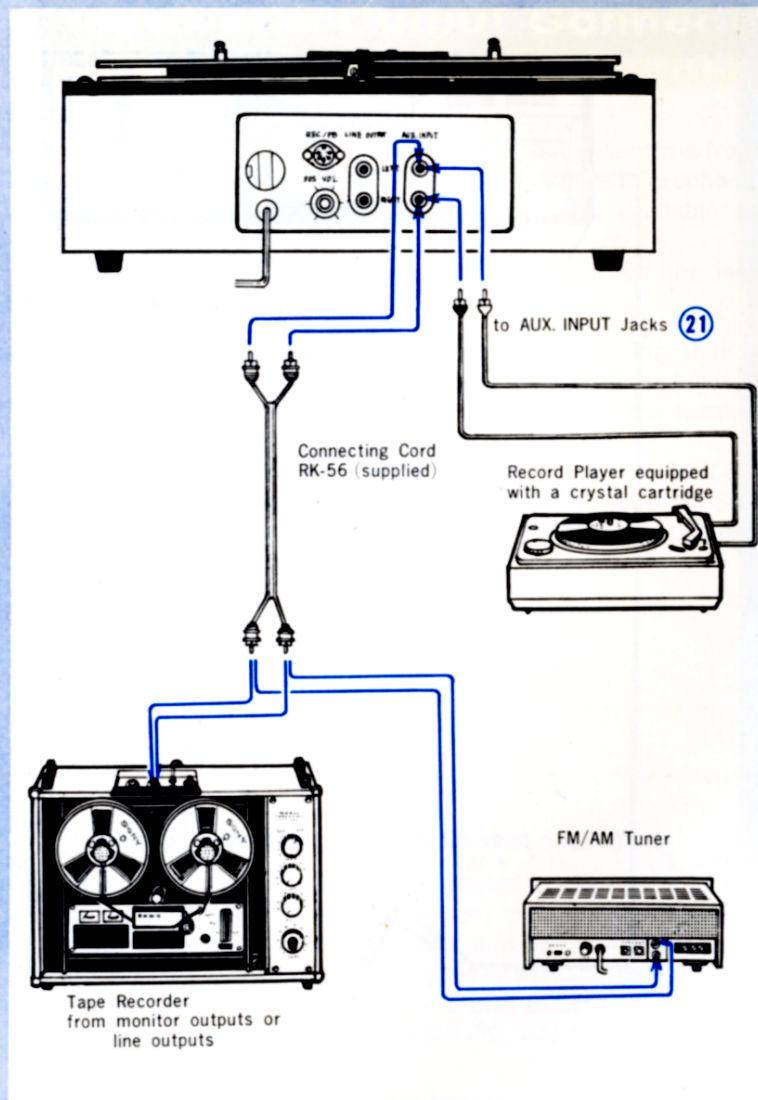

How to connect the recorder to an integrated amplifier

Connect left (CH-1) and right (CH-2) LINE OUTPUT JACKS 20 of the recorder to respective tape input jacks of an integrated amplifier (pre-amp/amplifier), using the supplied SONY Connecting Cord RK-56. Then, connect left (CH-1) and right (CH-2) AUXILIARY INPUT JACKS 21 of the recorder to respective tape output jacks of the integrated amplifier, using the other SONY Connecting Cord RK-56, which is also supplied with the recorder.

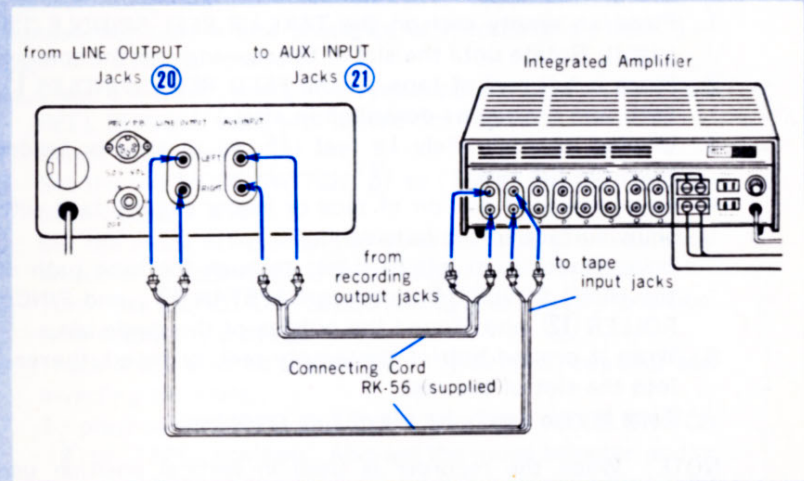

The 5 pin socket designated REC/PB. 22 is used for the interconnection of the model 350 high level inputs and outputs with an integrated amplifier that incorporates a matching socket. A SONY REC/PB Connector Cable RC-2 is available as an optional accessory.

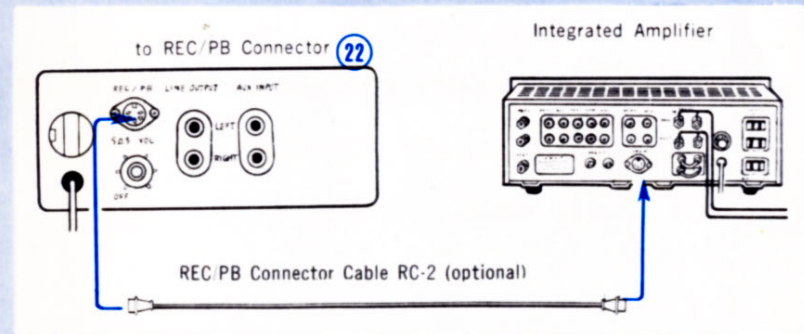

Threading Tape

Reel sizes from 3 to 7 inches in diameter are accommodated. Threading procedure is the same for all reel sizes.

1. Place an empty reel on the TAKE-UP REEL SPINDLE ⑮ (right). Rotate until the slot of the reel engages the spindle.
2. Place a full reel of tape on the FEED REEL SPINDLE ① (left) and engage as described in step 1.
3. Unwind approximately 1½ feet (45 cm) of tape or leader from the full reel.
4. Keep unwound portion of tape or leader slightly taut with shiny surface to the outside.
Bring leader from left to right; through the tape path of the HEAD COVER ⑭ between CAPSTAN ⑬, and PINCH ROLLER ⑫ and around the outside of the guide pin.
5. Wrap it around hub of the empty reel, or insert the end into the slot of the reel.
Tape is now ready for playing or recording.

NOTE: When the recorder is used in vertical position use rubber reel caps (supplied) to retain the reels on the recorder.

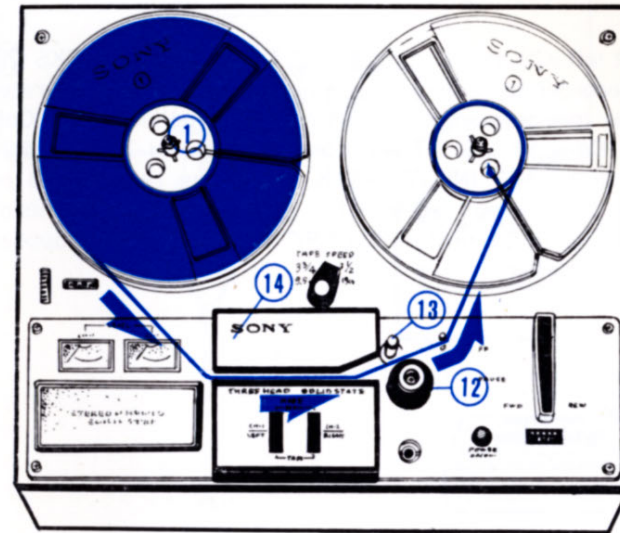

Playing Tapes

To Play Back 4-Track Stereo Tape

1. Place a 4-track pre-recorded tape with side 1 of the tape (tracks 1 and 3) up on the FEED REEL SPINDLE ① and thread the tape. (When the recorder is used in a vertical position, be sure to use both reel retaining caps. Do not use them when the recorder is in horizontal position.)
2. Select tape speed.
3. Set the MODE SWITCHES ⑧ to [TAPE] position.
4. Turn the FUNCTION SELECTOR ⑪ to [FWD] position.
Now the tracks 1 and 3 are playing.
(Playback output is obtained without passing through level control of the recorder.)
Adjustments for obtaining optimum volume level and sound quality should be performed by controls of the external integrated amplifier.
5. When the end of the tape is reached, do not rewind.
6. Invert and reverse the tape reels to playback tracks 4 and 2.
Place the full reel on the FEED REEL SPINDLE (left) and the empty reel on the TAKE-UP REEL SPINDLE (right).
7. Repeat operation step 4.

To Play Back 4-Track Monophonic Tape

The following playback procedure is recommended for a monophonic tape whose sequence of recording is; track 1—track 4—track 3—track 2.

1. Place a 4-track monophonic pre-recorded tape on the FEED REEL SPINDLE (left) and thread the tape.
2. Select tape speed.
3. Set the left MODE SWITCH ⑧ to [TAPE] position to playback tracks 1 and 4.
4. Set the mode selector and/or other controls of the external amplifier to reproduce the left channel (CH-1) sound.
5. Turn the FUNCTION SELECTOR ⑪ to [FWD] position.
Now track 1 is playing.
6. Track 4 will also be played back by simply reversing and inverting the reels.
7. To playback tracks 3 and 2, set the right MODE SWITCH ⑧ to [TAPE] position. Also set the mode selector and/or other controls of the external amplifier to reproduce right channel (CH-2) sound. Then turn the FUNCTION SELECTOR ⑪ to [FWD] position.

Recording

Before recording, try to estimate the input program playing time and provide more tape on the recorder than you think you will actually need.

NOTE: Be sure to check whether SOUND-ON-SOUND SWITCH/VOLUME CONTROL (18) marked [S.O.S. VOL] which is located on the back panel is in [OFF] position.

4-Track Stereo Recording

1. Thread the tape on the recorder.
2. Select the desired tape speed and reset the TAPE COUNTER (3).
3. Switch the function selector of the connected external amplifier according to the desired input program source for recording.

*When the recorder is not connected to an integrated amplifier, connect stereo source to proper input jacks of the recorder. (See page 8, INPUT AND OUTPUT CONNECTORS.)

4. Set the MODE SWITCHES (8) to [SOURCE] position and adjust recording level by turning RECORD LEVEL CONTROLS (6). See VU METERS (4).
5. Hold the RECORD BUTTON (7) in, turn FUNCTION SELECTOR (11) to [FWD] position. The RECORD BUTTON (7) is locked and recording on tracks 1 and 3 has started.
6. When the end of the tape is reached, do not rewind.
7. To record tracks 4 and 2, reverse and invert reels. Place the full reel on the FEED REEL SPINDLE (1) (left) and empty reel on the TAKE-UP REEL SPINDLE (15) (right).
8. Thread the tape again and repeat operation steps 4 and 5.

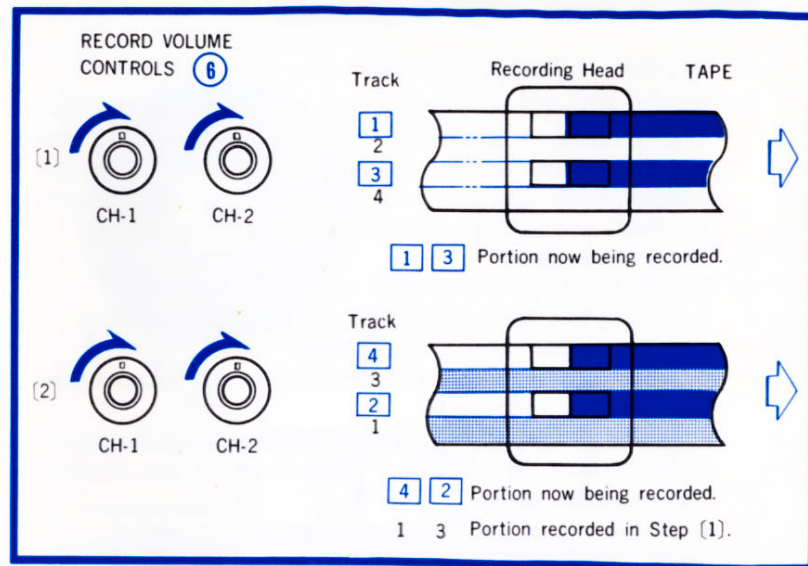

To Monitor While Recording

The professional feature of separate record and playback heads permits the monitoring of the recorded results while recording the same track (or tracks) by setting the MODE SWITCHES (8) to [TAPE] position.

When the external amplifier is equipped with a tape monitor switch, instantaneous comparison of the recordings and the recorded results is possible by turning on and off the tape monitor switch of the amplifier. In this case, the MODE SWITCHES (8) of the recorder should be in [TAPE] position.

Through the BINAURAL MONITOR JACK (9), an instantaneous comparison of the recordings and the recorded results is possible by the setting the MODE SWITCHES (8) alternately to [TAPE] and [SOURCE] positions.

When the REC/PB connector (22) of the recorder is used and the recorder is set in RECORD mode, the instantaneous tape/source monitoring should be done through the BINAURAL MONITOR JACK (9).

4-Track Monophonic Recording

1. Thread the tape on the recorder.
2. Select tape speed and reset the TAPE COUNTER **3**.
3. Switch the function selector of the external amplifier according to the desired input program source for recording.
 - *When the recorder is not connected to an external amplifier, connect the desired monophonic source to left channel (CH-1) input. (See page 8, INPUT AND OUTPUT CONNECTORS.)

Turn the right RECORD LEVEL CONTROL **6** fully counterclockwise to the [OFF] position until it clicks.

4. Set both MODE SWITCHES **8** to [SOURCE] position and adjust recording level by turning left RECORD LEVEL CONTROL **6**. See left VU METER **4**.
5. Hold the RECORD BUTTON **7** in, turn FUNCTION SELECT OR **11** to [FWD] position. The RECORD BUTTON **7** is locked and recording on track 1 has started.
6. When the end of the tape is reached, do not rewind.
7. Reverse and invert reels to record track 4. Place the full reel on the FEED REEL SPINDLE **1** (left) and the empty reel on the TAKE-UP REEL SPINDLE **15** (right).
8. To record tracks 3 and 2, turn left RECORD LEVEL CONTROL **6** fully counterclockwise to the [OFF] position until it clicks. Be sure to check whether the right MODE SWITCH **8** is set in the [SOURCE] position. Adjust recording level by the right RECORD LEVEL CONTROL **6** and right VU METER **4**.
9. Repeat operation steps 5, 6 and 7.

Playback sequence of each track should conform to the sequence of recording, i.e.

- | | |
|---------|----------------------|
| track 1 | left channel (CH-1) |
| track 4 | |
| track 3 | right channel (CH-2) |
| track 2 | |

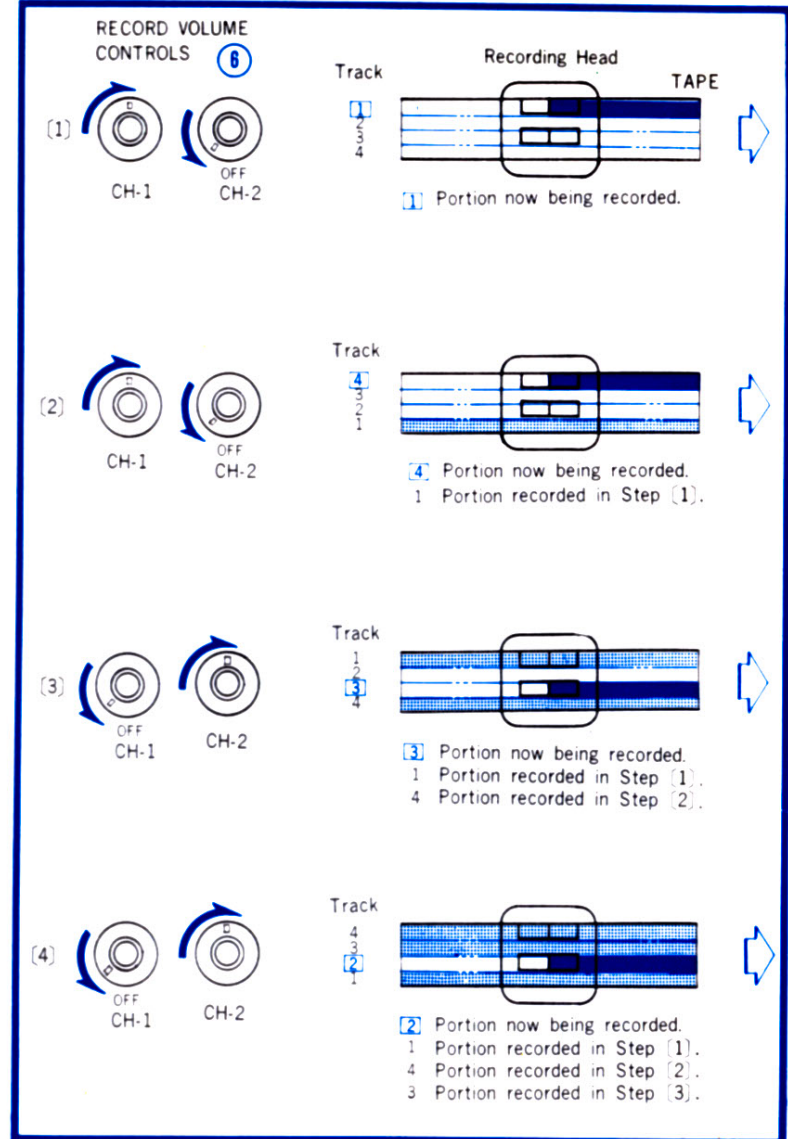

Erasing Tape

When the recorder is set in the record mode, the Erase Head will erase the track (or tracks) of the tape for the corresponding traces of the recording head. Therefore, when you start a new recording, any previous recordings are automatically erased as the tape passes the erase head.

You can also erase a tape without adding a new recording. Simply place the recorder in record mode by turning left (CH-1) and right (CH-2) RECORD LEVEL CONTROLS ⑥ fully counter-clockwise (but not turn off) and run the tape through. The tape will be erased more quickly by using a bulk eraser.

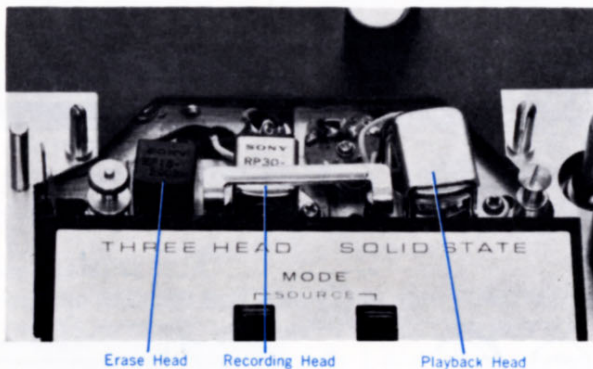

Splicing Tape

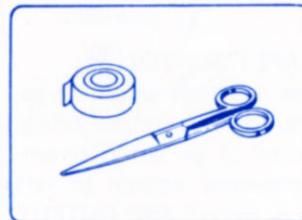

1. Use splicing tape and a pair of scissors.

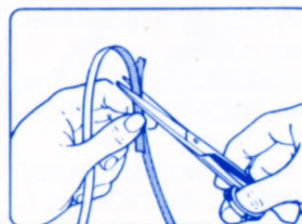

2. Overlap the recording tapes and make a diagonal cut across both tapes.

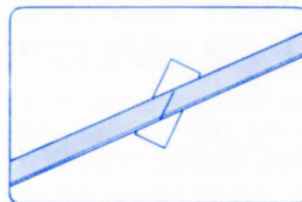

3. Carefully align and butt the cut ends together. Keep the ends in contact, firmly press a piece of splicing tape over the shiny side of the tape to make a firm joint.

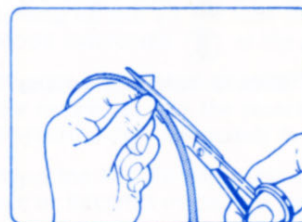

4. Trim off the excess splicing tape.

Sound-on-Sound Recording

This recorder is equipped to produce high quality professional 'sound-on-sound' composite recordings. A small amount of practice with the following procedures will enable you to become expert in the many fascinating uses of 'sound-on-sound' recordings.

Recording basic source material

1. Record basic source material on track 1 of the left channel (CH-1), as outlined under 4-track monophonic recording on page 15, and rewind the tape back to the beginning.

Recording composite information

2. Turn off the left (CH-1) RECORD LEVEL CONTROL (6) and set left (CH-1) MODE SWITCH (8) to [TAPE] position.

3. Turn on the SOUND-ON-SOUND SWITCH/VOLUME CONTROL (18) located at the rear side.
4. Plug in the right (CH-2) MICROPHONE INPUT (5).
5. Plug in high impedance headset to BINAURAL MONITOR JACK (9).
6. Listening through the headset, adjust and balance the recording level by rotating SOUND-ON-SOUND SWITCH/VOLUME CONTROL (18) and right (CH-2) RECORD LEVEL CONTROL (6).

NOTE: From the left (CH-1) headset, the playback of left channel (CH-1) is heard and from the right (CH-2) headset, the recorded results of the composite recordings is heard when the MODE SWITCHES (8) are set in [TAPE] position.

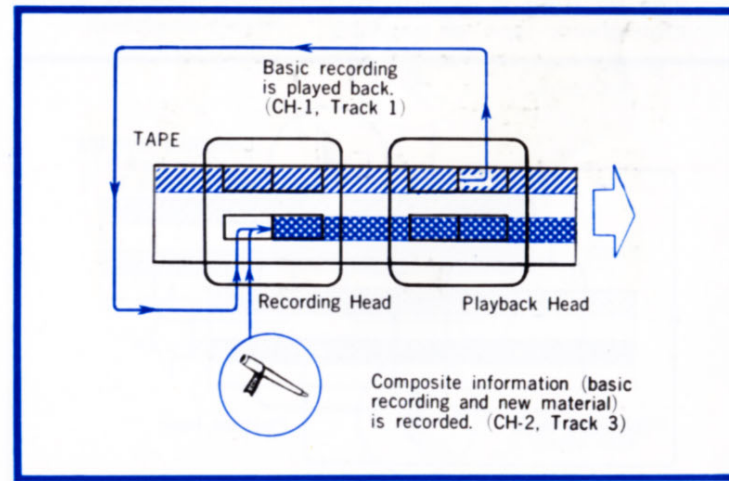
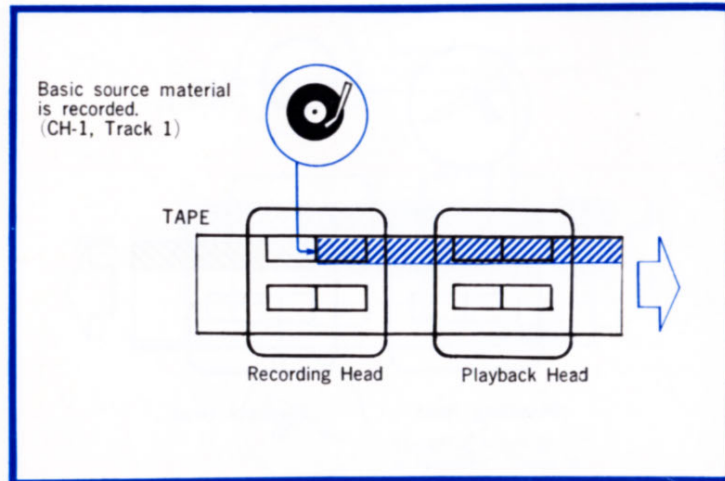

Tape Teaching

Left (CH-1) VU METER shows the playback level of the basic source material.

Right (CH-2) VU METER shows the level of the composite recordings being made.

A certain amount settings will insure both signals of the composite track being recorded in desired ratio.

7. When the end of the tape is reached, the composite information will have been recorded on track 3 of right (CH-2) channel.

NOTE: Sound-on-sound recording is possible only from left channel (CH-1) to right channel (CH-2).

8. Be sure to turn OFF the SOUND-ON-SOUND SWITCH/ VOLUME CONTROL **18** when the composite recording is completed.

Playback

9. Rewind the tape back to the beginning and playback recordings on track 3 as outlined under 'To playback 4-track monophonic tape' on page 13.

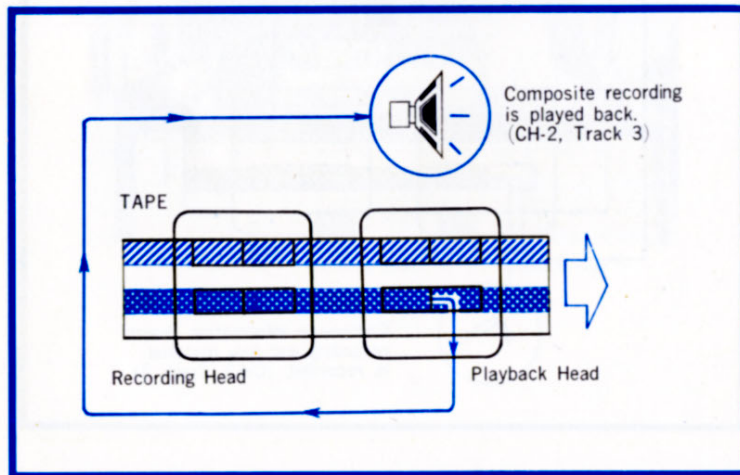

- This recorder provides facilities to play back one track while the other track is being recorded. This exclusive feature is ideal for language students who wish to listen to a pre-recorded lesson on one track while recording the answers or repetitions on the other track. Both tracks can later be played back separately or simultaneously for comparison.

Master recording

1. Record teacher's program on track 1 (left channel, CH-1) according to 4-track monophonic recording on page 15, and rewind the tape back to the beginning.

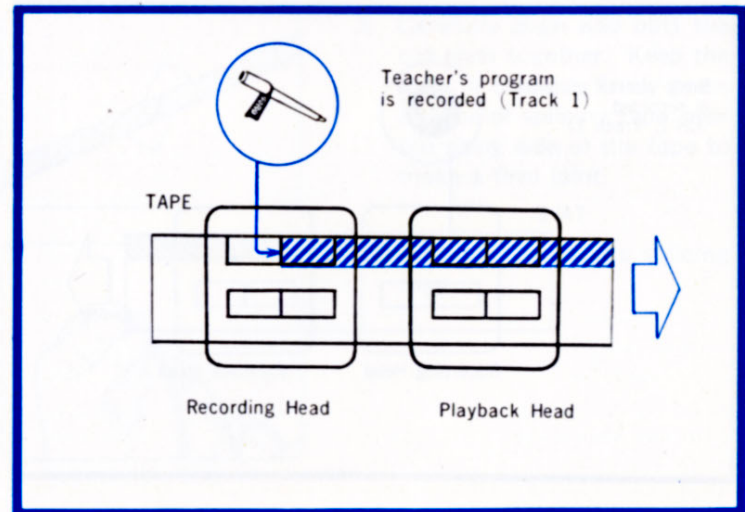

Practice recording

2. Turn OFF the left (CH-1) RECORD LEVEL CONTROL ⑥ and set the left (CH-1) MODE SWITCH ⑧ to [TAPE] position.
3. Connect the headset to the BINAURAL MONITOR JACK ⑨.
4. Connect the microphone to the right (CH-2) MICROPHONE INPUT JACK ⑤.
5. Turn ON the right (CH-2) RECORD LEVEL CONTROL ⑥ and record your practice recordings on track 3 (right channel, (CH-2)) by repeating or answering the master recording which is heard through the headset.

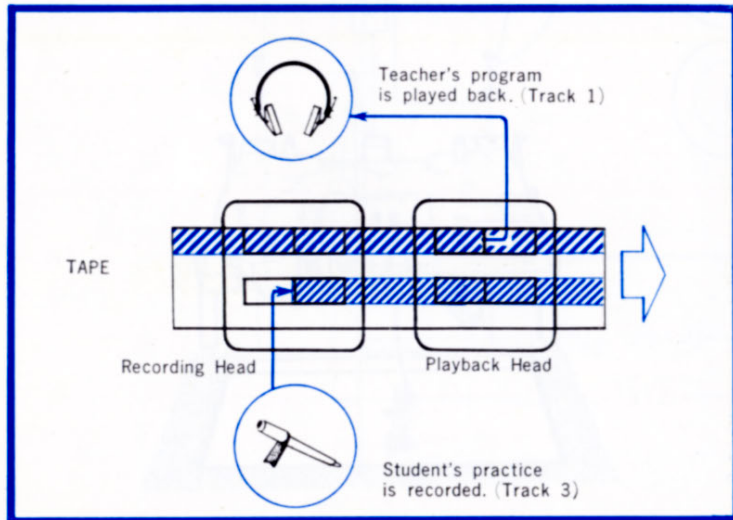

Simultaneous playback

6. Rewind and playback the tape in the same manner as a stereo tape; then, the master track and the practice track are simultaneously reproduced.

In the above method, the master and the practice recordings are made separately on different channels, so that the practice track can be repeatedly recorded without erasing the master track.

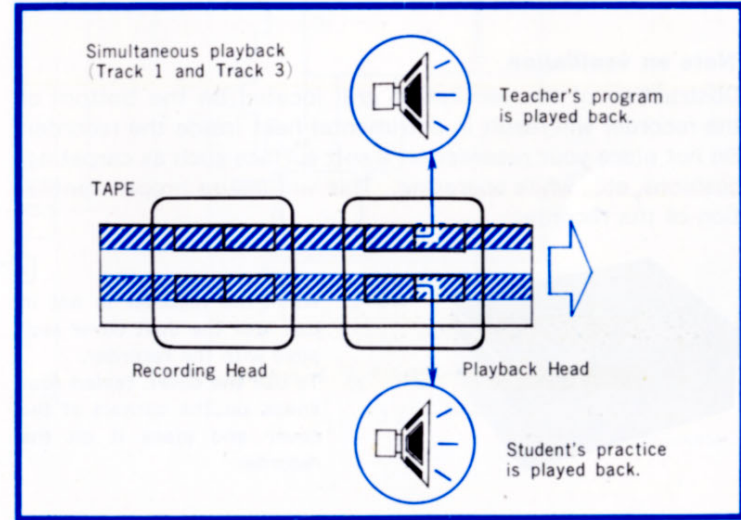

How to Mount Model TC-350

The model TC-350 can be installed in either horizontal or vertical position.

1. Cut hole of $15 \times 11\frac{1}{2}$ " (380×292 mm) in desired mounting location.
2. Remove FUNCTION SELECTOR knob, TAPE SPEED SELECTOR knob, HEAD COVER, RECORD LEVEL CONTROL knobs, PINCH ROLLER and five Philips mounting screws from the top panel and lift up the panel.
3. Remove deck from wooden base by unscrewing (turn counterclockwise) four rubber bases and a screw from the bottom of the wooden base.
4. Mount deck in new location and fasten with three wood screws (supplied).
5. Place the top panel on top of the deck and replace the parts removed in Step 2.

Note on ventilation

Obstruction of the ventilation grill located on the bottom of the recorder will result in detrimental heat inside the recorder. Do not place your recorder on a soft surface such as carpeting, cushions, etc., while operating. This will insure proper ventilation of the recorder.



NOTE: When the recorder is not in use, use the dust cover supplied with the recorder. To use the cover, fasten four snaps on the corners of the cover and place it on the recorder.

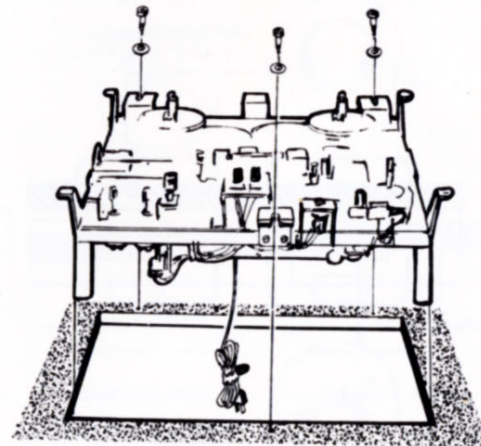
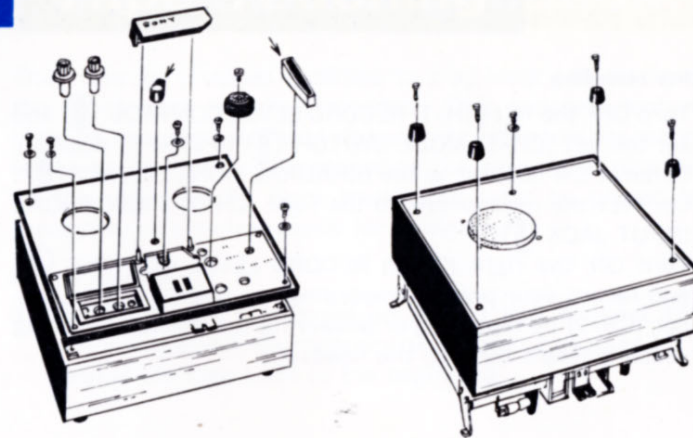

Mounting Dimensions

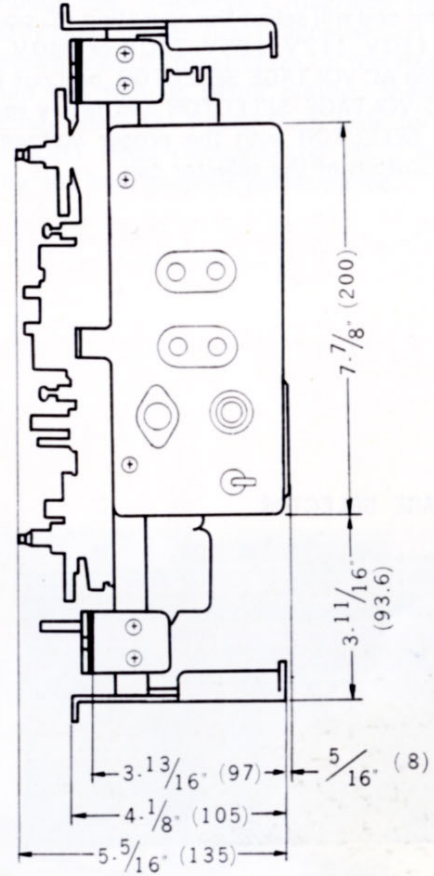
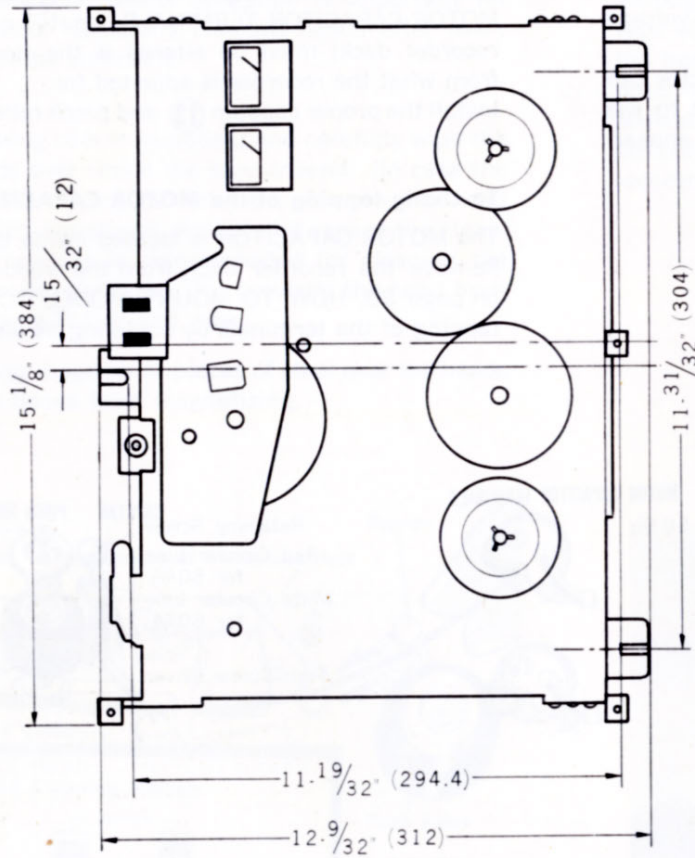

(millimeter)

Adaptation to the Local Power Line

To set operating voltage

The AC VOLTAGE SELECTOR (17) is located at the rear side of the recorder and will select the operating AC power line voltage of 100V, 110V, 117V, 125V, 220V or 240V.

To reset the AC VOLTAGE SELECTOR, pull out the selector cap of the AC VOLTAGE SELECTOR and firmly re-insert it to the VOLTAGE SELECTOR with the proper voltage figure appearing in the cutout of the selector cap.

AC VOLTAGE SELECTOR

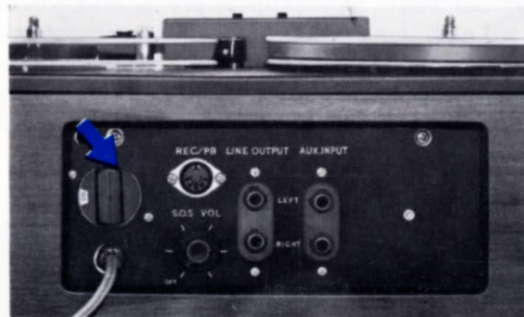

AC frequency requirement

The PINCH ROLLER (12), CAPSTAN (13) and tapping of the MOTOR CAPACITOR TERMINALS (located on the bottom of the recorder deck) must be altered if the line frequency differs from what the recorder is adjusted for.

Install the proper capstan (13) and pinch roller (12) as illustrated.

To change tapping of the MOTOR CAPACITOR TERMINALS

The MOTOR CAPACITOR is located inside the recorder. Remove the recorder deck from the wooden base as outlined on page 20, HOW TO MOUNT MODEL TC-350. Change the tapping of the terminals by soldering as illustrated.

MOTOR CAPACITOR TERMINALS

50 c/s



60 c/s

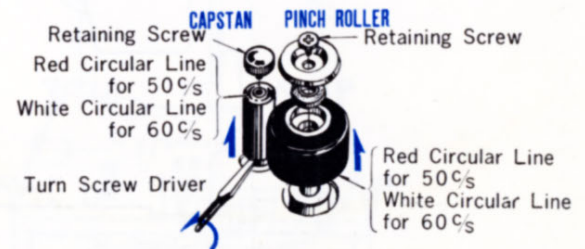

Maintenance

Cleaning heads

Intimate contact between heads and tape is important for optimum performance. Generally, cleaning heads after every ten hours of use will be sufficient.

TO CLEAN

Take the head cleaning ribbon (supplied) and carefully wipe the portion of the heads over which the tape travels. (In case the deposits on the head cannot be removed, dampen the head cleaning ribbon with denatured alcohol and repeat the cleaning.) The same procedure is recommended for cleaning the capstan and pinch roller surfaces. This prevents the head from oxide deposits causing flutter and wow.

NOTE: Do not bring magnets or pieces of steel near the heads to prevent heads from magnetizing.

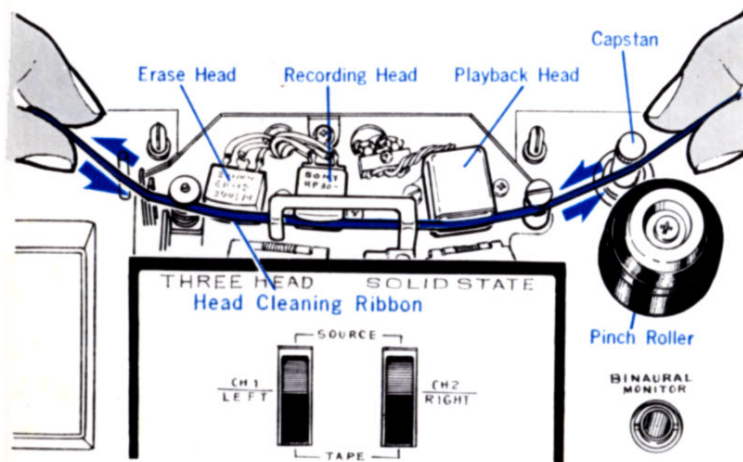

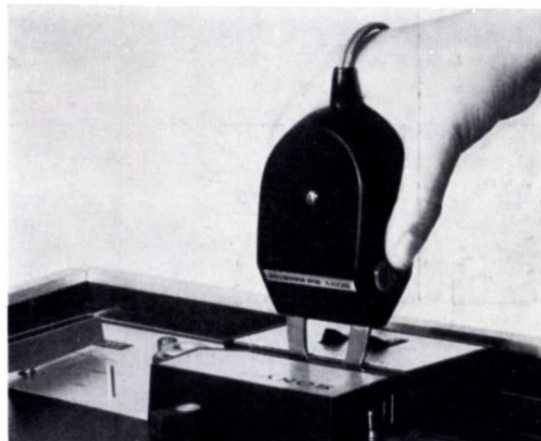

Demagnetizing heads

Through continuous use, the varying magnetic fields of the tape will gradually build up residual magnetism on the gap of the head. Excessive residual magnetism on the head will produce noise while the tape is being played; therefore it is advisable to demagnetize the heads from time to time. The periodic use of SONY Head Demagnetizer HE-2 (optional) is recommended for the best possible performance.

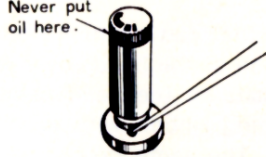
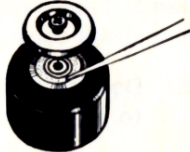

Lubrication chart

Parts to lubricate	Quantity of oil every 6 months	Type of oil	Remarks	Figures
Capstan bearings	3 drops	Light machine oil	Don't stain capstan surface	 <p>Never put oil here.</p>
Pinch roller bearings	1 drop	Light machine oil	Don't stain rubber surface	
Idler shafts	1 drop	Light machine oil	Remove top cover panel to gain access (see page 20)	
Reel shafts	1 drop	Light machine oil		

- NOTE: (1) Avoid excessive lubrication. It will cause slippage in the mechanism and contamination of your tape.
 (2) If stalling occurs in FAST FORWARD motion, clean each rubber idler wheel under the top panel with a soft cloth moistened with denatured alcohol.

Schematic Diagram

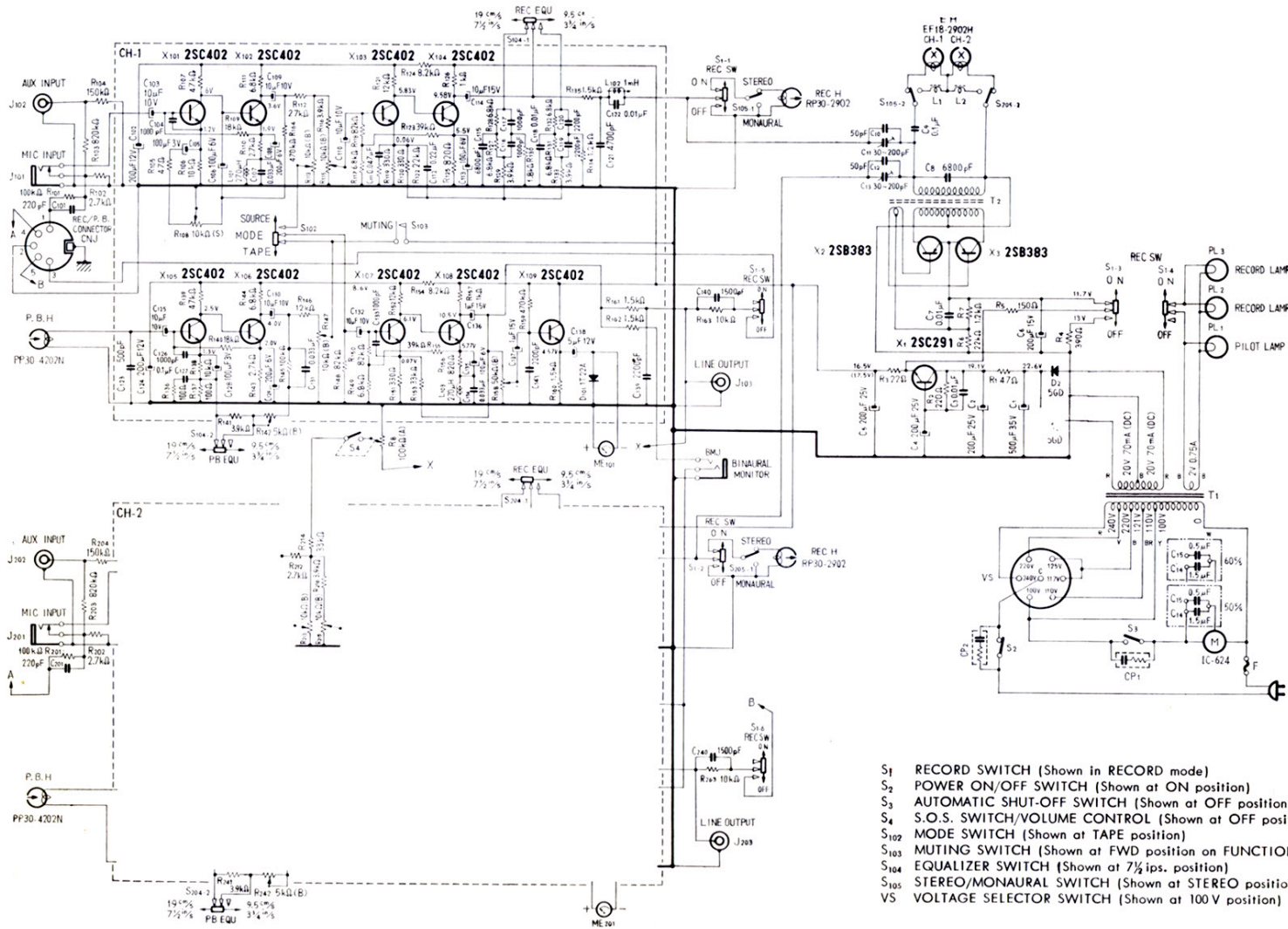

- S1 RECORD SWITCH (Shown in RECORD mode)
- S2 POWER ON/OFF SWITCH (Shown at ON position)
- S3 AUTOMATIC SHUT-OFF SWITCH (Shown at OFF position)
- S4 S.O.S. SWITCH/VOLUME CONTROL (Shown at OFF position)
- S102 MODE SWITCH (Shown at TAPE position)
- S103 MUTING SWITCH (Shown at FWD position on FUNCTION SELECTOR)
- S104 EQUALIZER SWITCH (Shown at 7 1/2 ips. position)
- S105 STEREO/MONURAL SWITCH (Shown at STEREO position)
- VS VOLTAGE SELECTOR SWITCH (Shown at 100 V position)

Recommended Accessories

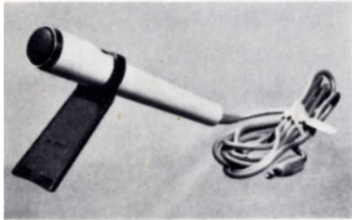

Microphone F-96

A wide range, general purpose, omni-directional dynamic microphone of low impedance (600 ohms).



Stereo Headset DR-3C

High quality dynamic headset of high impedance (10K ohms) with a standard phone plug for private stereo listening or monitoring while recording.

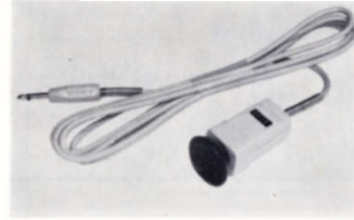

Telephone Pick-up TP-4S

For recording of telephone conversation on tape.

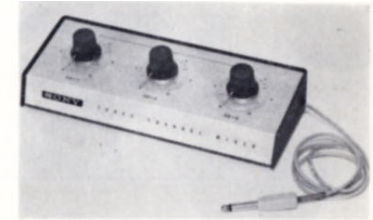

Microphone Mixer MX-600

3-channel, 600 ohms MIC and/or LINE INPUT mixer with independent volume control for each channel.

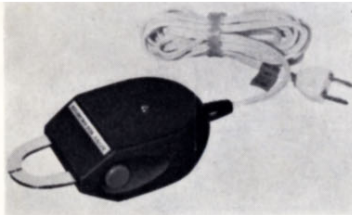

Head Demagnetizer HE-2

For quick and easy demagnetizing of the magnetic heads to keep the recorder in the best reproducing condition.

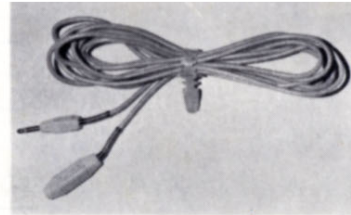

Microphone Extension Cords EC-5M, -10M, -25M

EC-5M (approx. 16 feet, 5 meter long), EC-10M (approx. 33 feet, 10 meter long), EC-25M (approx. 82 feet, 25 meter long) series of microphone cords for extension of microphone.

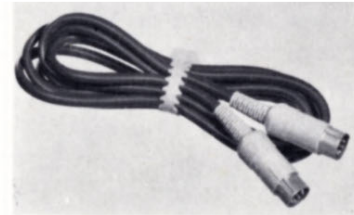

REC/PB Connector Cable RC-2

Connector cable with 5-pin connector for recording from or reproducing through an integrated amplifier (pre-amp/amplifier).

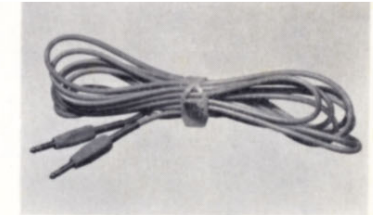

Connecting Cord RK-34

Approx. 10 feet (3 meter) long cord with mini-plug on both ends.

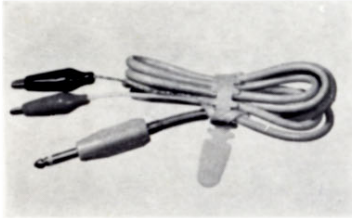

Connecting Cord RK-36

Approx. 3 feet (1 meter) long cord with mini-plug on one end and alligator clips on the other end.

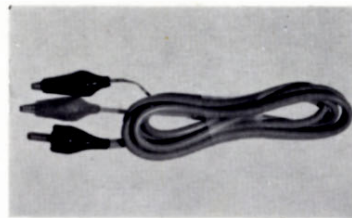

Connecting Cord RK-46

Approx. 3 feet (1 meter) long cord with phono-plug on one end and alligator clips on the other end.

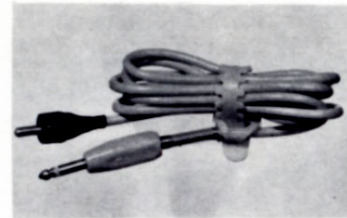

Connecting Cord RK-50

Approx. 3 feet long (1 meter) long cord with phono-plug on one end and mini-plug on the other end.

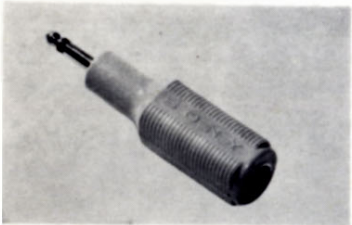

Plug Adaptor PC-1

Adapts standard phone plug connectors to fit mini jacks.

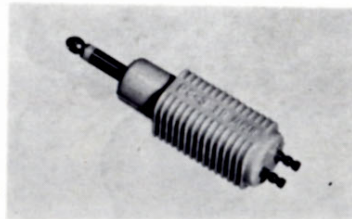

Plug Adaptor PC-3

Incorporates 8 ohm resistor. For recording from external speaker jack of a tape recorder or from an earphone jack of a transistor radio. Fits mini jacks.



Plug Adaptor PC-5

Adapts mini-plug connectors to fit phono jacks.

SONY®

STEREO TAPECORDER TC-350

OWNER'S INSTRUCTION MANUAL

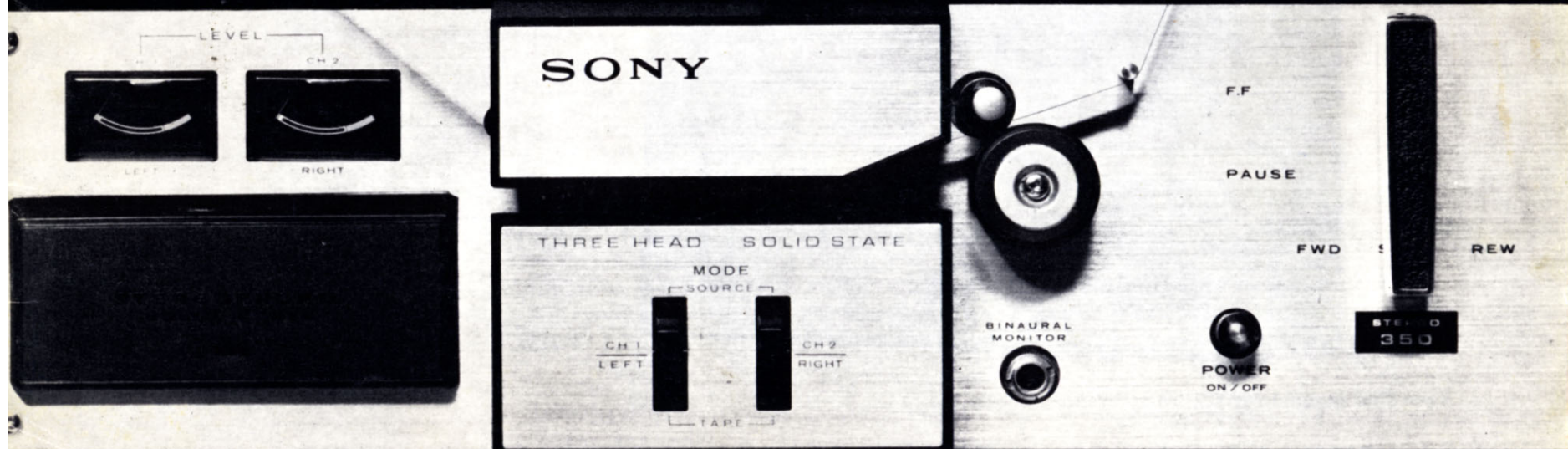

Your new SONY Model TC-350 stereo tape recorder is a 4-track solid state instrument of superior performance, built to exacting SONY tape recorder standards. Providing outstanding versatility, ease of operation with vertical or horizontal operating position and the professional features of sound-on-sound and tape/source monitoring. The 3-head TC-350 will enhance your hi-fi sound system.

Read the information contained in this manual carefully before operating the recorder

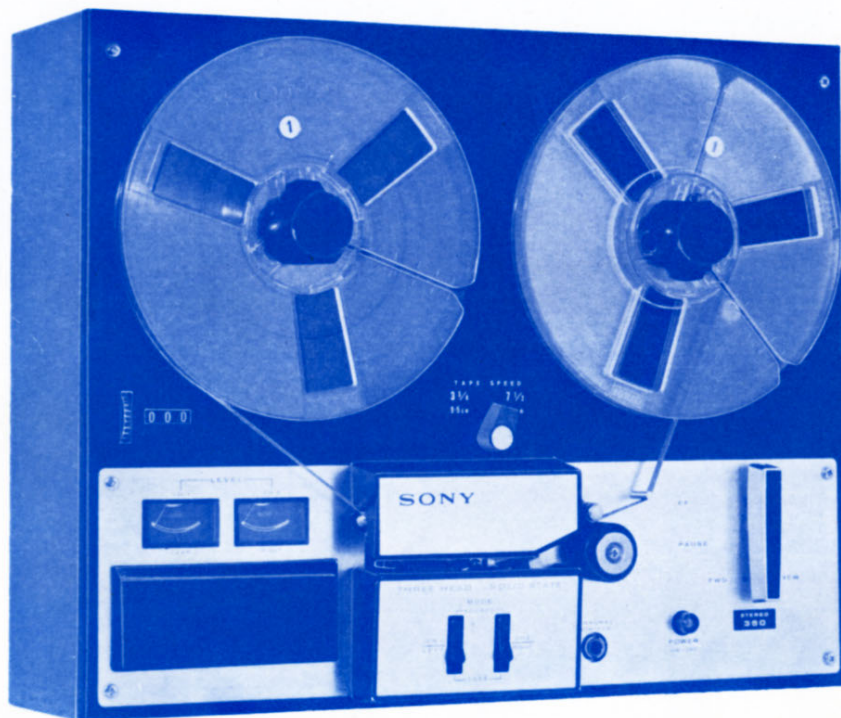

Save this manual for future reference.

Technical Specifications

Power requirements: 50 watts, 100, 110, 117, 125, 220 or 240 volts, 50/60 cycles AC

Tape width: ½ inch

Reels: 7 inches or smaller

Tape speed: Instantaneous selection 7½ ips. (19 cm/sec.) or 3¾ ips. (9.5 cm/sec.) with automatic equalization change

Recording system: 4-track stereophonic or monophonic

Frequency response: 30-20,000 c/s at 7½ ips. (19 cm/sec.) ±3 db
50-15,000 c/s at 7½ ips. (19 cm/sec.)
30-14,000 c/s at 3¾ ips. (9.5 cm/sec.)

Signal-to-Noise ratio: tape speed peak record level to unweighted noise

7½ ips. (19 cm/sec.)	50 db or better
3¾ ips. (9.5 cm/sec.)	50 db or better

* The peak record level is defined as that level at which the overall (input to output on 'line output jack') total RMS harmonic distortion does not exceed 3% when measured on a 400 cycle tone. Noise is measured by playing an erased portion of the tape, on which a signal of peak recording level was present prior to erasure. This will produce the overall figure of noise, including the bias and erase noise, as well as record and playback amplifier noise.

Flutter and wow: tape speed

7½ ips. (19 cm/sec.)	less than 0.17% RMS
3¾ ips. (9.5 cm/sec.)	less than 0.25% RMS

* The flutter and wow measurements include all components between 0.5 and 250 cycles.

Harmonic distortion: less than 3% at 0 db line output

Level indication: two VU meters

record: NAB standard

playback: calibrated to 0 db at 0 db line output

Recording time:

		4-track	
		4-track stereo	monophonic
1,200' tape	7½ ips. (19 cm/sec.)	1 hr.	2 hrs.
	3¾ ips. (9.5 cm/sec.)	2 hrs.	4 hrs.
1,800' tape	7½ ips. (19 cm/sec.)	1 hr. 30 min.	3 hrs.
	3¾ ips. (9.5 cm/sec.)	3 hrs.	6 hrs.

Fast forward and rewind time:

within 4 min. (1,200' tape)

Inputs: Microphone inputs

Sensitivity: -72 db (0.19 mV)

Impedance: low (will accommodate any microphone from 250~1K ohm impedance)

Auxiliary inputs

Sensitivity: -22 db (0.06 V)

Impedance: approx. 100K ohms

Integrated record/playback connector

Sensitivity: -42 db (6.15 mV)

Impedance: approx. 100K ohms

Outputs: Line outputs
 Output level: 0 db (0.775 V)
 Impedance: optimum load impedance 100K ohms
 Binaural monitor jack
 Output level: -1 db (0.692 V)
 Impedance: accommodates 10K ohm headset
 Integrated record/playback connector
 Output level: 0 db (0.775 V)
 Impedance: optimum load impedance 500K ohms

Heads: Recording head RP 30-2902
 Playback head PP 30-4202 N
 Erase head EF 18-2902 H

Transistors: 2 SC 402 × 18
 2 SB 381 × 2
 2 SC 291 × 1

Diodes: 1 T 22 A × 2
 5 G-D × 2

Dimensions: 15½ (w) × 6¾ (h) × 13 (d)''
 (400 × 160 × 320 mm)

Weight: 17 lb 3 oz
 (8 kg)

Table of Contents

Diagram of controls and connectors 3
 Operation of controls 5
 input and output connectors 8
 How to connect the recorder to
 an integrated amplifier.....11
 Threading tape12
 Playing tapes13
 To play back 4-track stereo tape
 To play back 4-track monophonic tape
 Recording14
 4-track stereo recording
 To monitor while recording
 4-track monophonic recording
 Erasing tape16
 Splicing tape16
 Sound-on-sound recording17
 Tape teaching.....18
 How to mount Model TC-350.....20
 Mounting dimensions.....21
 Adaptation to the local power line.....22
 Maintenance23
 Cleaning heads
 Demagnetizing heads
 Lubrication chart
 Schematic diagram25
 Recommended accessories26

Diagram of Controls and Connectors

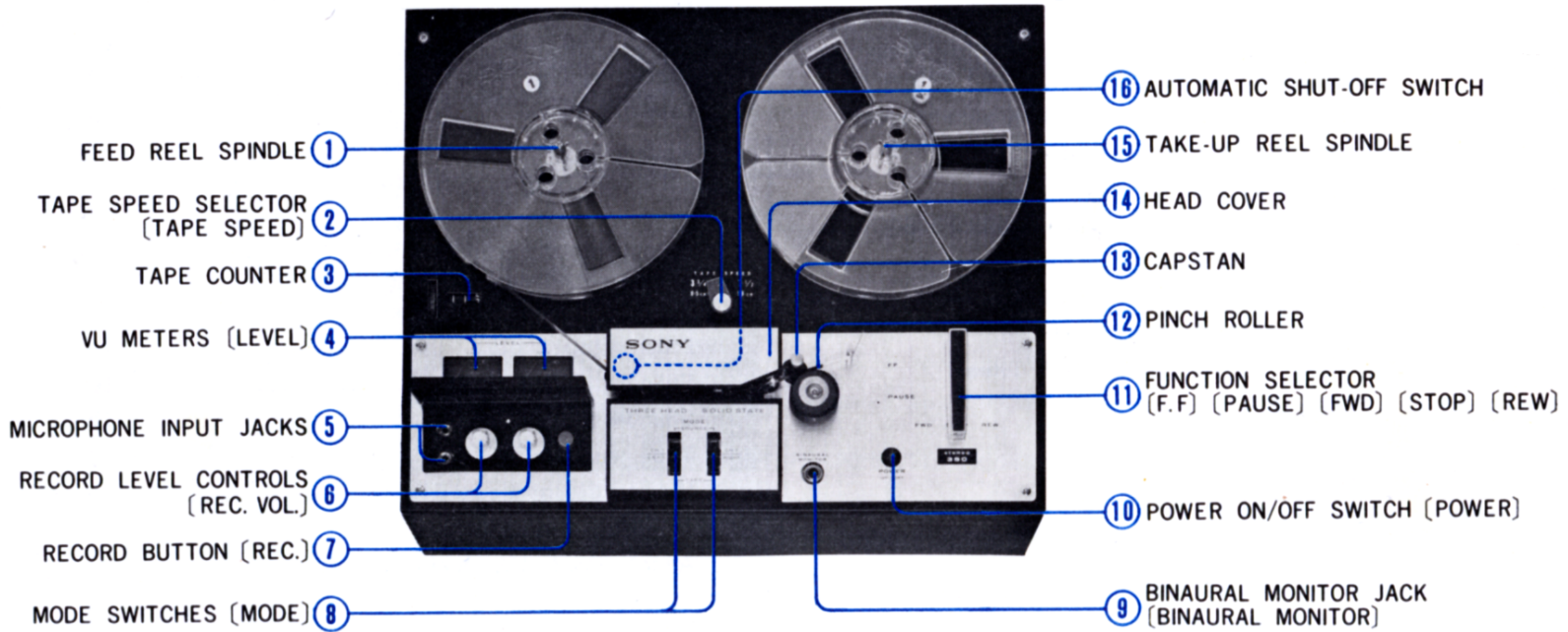

Refer to OPERATION of CONTROLS on page 5 ~ 8.

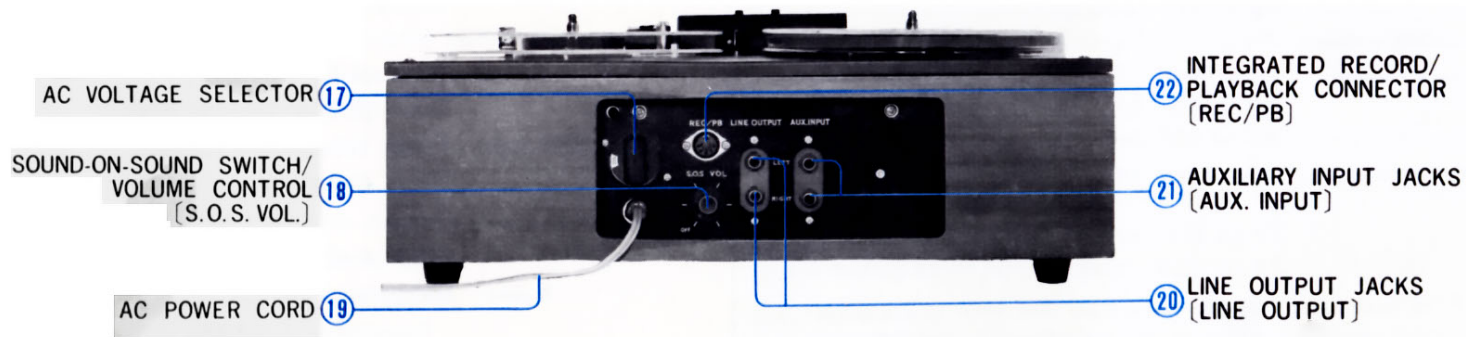

Your SONY tape recorder can be set for operating on AC voltage of 100, 110, 117, 125, 220 or 240 volts, and line frequency of either 50 or 60 cycles.

Before connecting the recorder to the power line, be sure to check whether the recorder is set for operating AC voltage and line frequency identical to the local power supply in your area.

Simple instructions for this adjustment are contained on page 22, ADAPTATION TO THE LOCAL POWER LINE.

Refer to INPUT AND OUTPUT CONNECTORS on page 8 ~ 10.

Operation of Controls

① FEED REEL SPINDLE

② TAPE SPEED SELECTOR [TAPE SPEED]

Selects tape speed of either 7½ ips. (19 cm/sec.) when better sound quality is desired, or 3½ ips. (9.5 cm/sec.) when longer recording time is desired.

To change from 3½ ips. (9.5 cm/sec.) to 7½ ips. (19 cm/sec.), press down on the selector knob and turn clockwise to 7½ ips. (19 cm/sec.). To change from 7½ ips. (19 cm/sec.) to 3½ ips. (9.5 cm/sec.), turn the knob counterclockwise and allow the knob to rise.

③ TAPE COUNTER

Indicates the amount of tape used in either record or playback. To reset the tape counter, rotate reset wheel, located to the left of numbers, upward until three zeros [000] appear in the window.

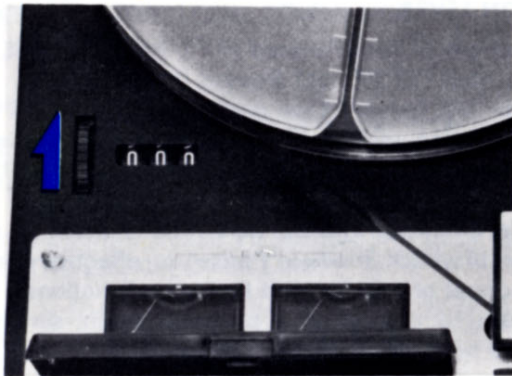

④ VU METERS

Indicates the level of signal being recorded or playback according to the position of the MODE SWITCHES ⑧.

When the MODE SWITCH is set in [SOURCE] position: these meters are calibrated to NAB standard allowing the maximum recording level without distortion.

For best recording results, the RECORD LEVEL CONTROLS ⑥ should be adjusted so that the deflection of the VU METER needle does not continuously remain in the red zone. It is normal for occasional transient peaks to deflect the needle into the red zone.

When the MODE SWITCH is set in [TAPE] position: the tape being recorded can be monitored while the recorder is in RECORD mode. For playback these meters are calibrated so that the needle points to the boundary of red and black zones when the line output level, is approx. 0 db (0.775 V).

⑤ MICROPHONE INPUT JACKS [MIC]

See page 8, INPUT AND OUTPUT CONNECTORS.

⑥ RECORD LEVEL CONTROLS [REC. VOL.]

Controls level of signal being recorded.

The knob marked [LEFT] is for left channel (CH-1) and the knob marked [RIGHT] is for right channel (CH-2). To increase turn clockwise and to decrease turn counterclockwise. When turned fully counterclockwise to [OFF] position with a click, bias and erase currents to the respective channel are shut off, thus making possible 4-track monophonic recording.

NOTE: These controls have no effect upon playback level.

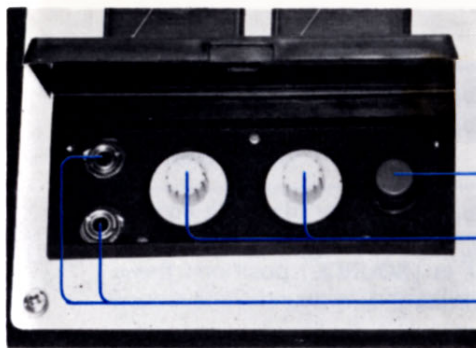

⑦ RECORD BUTTON [REC.]

⑧ RECORD LEVEL CONTROLS [REC. VOL.]

⑤ MICROPHONE INPUT JACKS [MIC]

⑦ RECORD BUTTON

Activates RECORD mode switch.

While pressing the button, turn the FUNCTION SELECTOR to [FWD] position; the tape motion will start and red lamps in the VU METERS will illuminate indicating that the recorder is in RECORD mode.

NOTE: When the FUNCTION SELECTOR is set to [STOP] position, the RECORD BUTTON will be released and the recorder will automatically switch from record to playback.

⑧ MODE SWITCHES [MODE]

Has two positions: [SOURCE] and [TAPE].

[SOURCE] The input program source is connected to LINE OUTPUT JACKS ⑳, output of INTEGRATED RECORD/PLAYBACK CONNECTOR ㉒ and BINAURAL MONITOR JACK ⑨.

The VU METER needle deflection shows the level of the input program source. With this feature, the recording level can be previously adjusted without pressing RECORD BUTTON.

[TAPE] For playback, set the switches to this position. The deflection of the VU METER needle shows the playback level.

For instantaneous tape monitoring while recording, set the switches to this position.

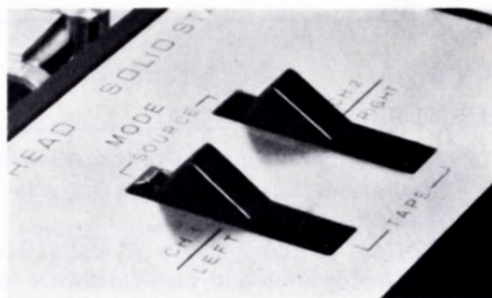

⑨ BINAURAL MONITOR JACK [BINAURAL MONITOR]

See page 8, INPUT AND OUTPUT CONNECTORS.

⑩ POWER ON/OFF SWITCH [POWER]

Press to turn the recorder ON. The button is locked and the lamp illuminates. Press again to turn OFF.

⑪ FUNCTION LEVER

Has five positions of Fast Forward [F.F.], Pause [PAUSE], Forward [FWD], Stop [STOP] and Rewind [REW].

[F.F.] For fast forward tape motion.

The tape motion can be stopped by turning the FUNCTION SELECTOR to [PAUSE] or [STOP] position.

[PAUSE] To momentarily stop tape motion either in record or playback mode. 'Pause' is effective for both normal or fast forward tape speed motions. To return to recording or playback again, simply turn the selector to [FWD] position.

[FWD] To move the tape at normal tape speed for recording or playback.

NOTE: While recording if the selector is set to [STOP] position, the recorder will automatically switch from record to playback mode.

[STOP] To stop the tape motion.

Always keep the selector in [STOP] position, when the recorder is not in use.

[REW] To rewind the tape.

NOTE: a. Change from [REW] to [FWD] (or vice versa) must be made by bringing the tape to a complete stop in [STOP] position.

b. Change from [F.F] to [FWD] must be made by bringing the tape to a complete stop in [PAUSE] position.

12 PINCH ROLLER

Presses the tape against the capstan to drive the tape.

If the line frequency differs from what the recorder is adjusted for, the PINCH ROLLER, as well as capstan and the tapping of the motor capacitor terminals should be altered. See page 22, ADAPTATION TO THE LOCAL POWER LINE.

13 CAPSTAN

Drives the tape at a constant speed.

If the line frequency differs from what the recorder is adjusted for, the CAPSTAN, pinch roller and the tapping of the motor capacitor terminals should be altered. See page 22, ADAPTATION TO THE LOCAL POWER LINE.

14 HEAD COVER

Protects heads. When cleaning the heads, remove the cover by pulling it up.

15 TAKE-UP REEL SPINDLE

16 AUTOMATIC SHUT-OFF SWITCH

This switch is controlled by a wire lever located under the head cover. In [STOP] position the shut-off lever recedes into a slot to facilitate easy tape threading. After tape is threaded and the mechanism is placed in either Forward [FWD], Fast Forward [F.F] or Rewind [REW] mode, the shut-off lever contacts the tape and is held in this position.

At such time as the tape either runs out or breaks, the lever will automatically fall forward and activate a micro switch which stops tape motion; however, the internal amplifiers are still ON.

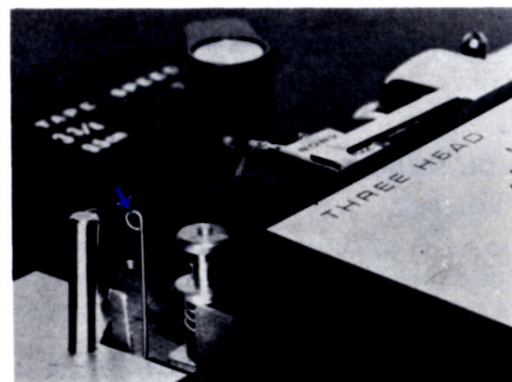

Input and Output Connectors

17 AC VOLTAGE SELECTOR

Selects the operating AC power line voltage of 100V, 110V, 117V, 125V, 220V or 240V.

Before connecting the recorder to power line, check whether the selector is correctly set for operating the local power supply voltage in your area.

To reset the selector, pull out the selector cap and firmly reinsert it to the VOLTAGE SELECTOR with the proper voltage figure appearing in the cutout of the selector cap.

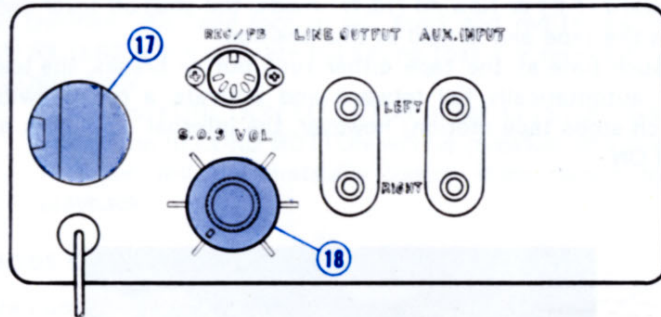

18 SOUND-ON-SOUND SWITCH/VOLUME CONTROL [S.O.S. VOL.]

Activates sound-on-sound record mode and also controls left channel (CH-1) playback level for composite recordings. For sound-on-sound recording, turn the knob clockwise from [OFF] position and adjust the volume level.

IMPORTANT: Be sure the S.O.S. SWITCH/VOLUME CONTROL is turned off when this facility is not being used.

5 MICROPHONE INPUT JACKS [MIC]

These mini jack inputs are located at the left side of the front panel and accept any high quality low impedance microphone. The low impedance SONY F-96 microphones available as optional accessories are recommended.

The jack marked [L] is for left channel (CH-1) and the jack marked [R] is for right channel (CH-2).

NOTE: When recording with a microphone, howling sounds (acoustic feedback) may occur if the microphone is too near the speakers. In this case, reduce the speaker volume or turn the speaker switch off.

These inputs can also be used with a telephone pickup SONY model TP-4S (optional), microphone mixer SONY model MX-600 (optional) for microphone and line mixing, SONY radio equipped with a recording jack.

9 BINAURAL MONITOR JACK [BINAURAL MONITOR]

A standard binaural phone jack is located at the center of the front panel. This output connects to any high impedance stereo headset which is equipped with a standard binaural phone plug. It enables stereo headset monitoring of either 'source' or 'tape' when used in conjunction with the MODE SWITCHES 8.

Ideal headset is the SONY model DR-3C, which is available as an optional accessory.

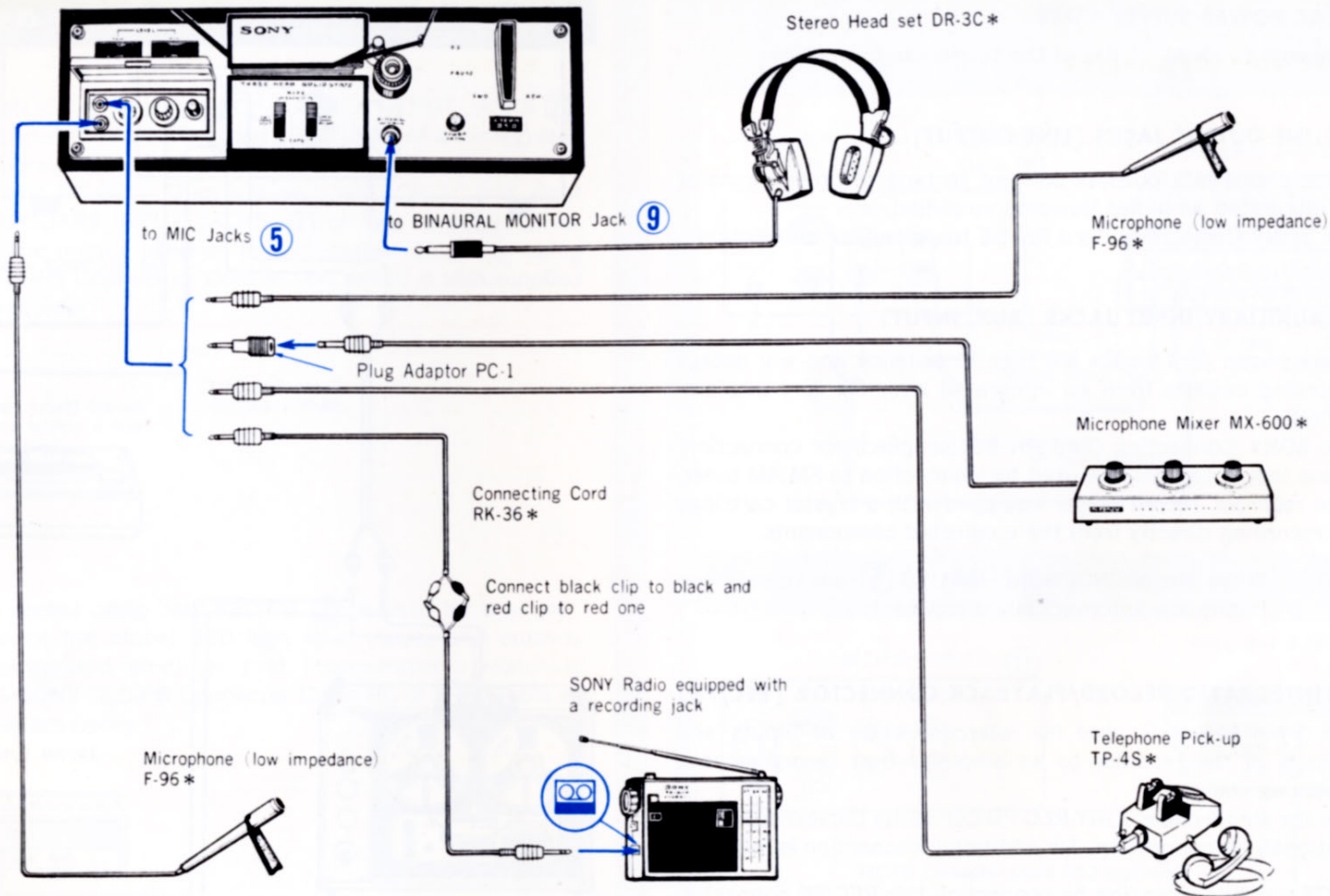

Accessories marked * are available separately

19 AC POWER SUPPLY CORD

Connects to an AC outlet of the household power line.

20 LINE OUTPUT JACKS [LINE OUTPUT]

These phono jack outputs connect to tape recorder inputs of an integrated amplifier (pre-amp/amplifier). Use SONY Connecting Cord RK-56 (supplied) for connection.

21 AUXILIARY INPUT JACKS [AUX. INPUT]

These phono jack inputs are high impedance and will accept recording outputs from an integrated amplifier (pre-amp/amplifier). Use SONY Connecting Cord RK-56 (supplied) for connection. These inputs can also be used for connection to FM/AM tuner, tape recorder, record player equipped with a crystal cartridge for recording directly from the connected components.

NOTE: When the MICROPHONE INPUTS 5 are used, these inputs are automatically disconnected.

22 INTEGRATED RECORD/PLAYBACK CONNECTOR [REC/PB]

The 5-pin socket is used for interconnection of inputs and outputs of the recorder to an amplifier that incorporates a matching socket. Use the single cable SONY REC/PB Connector Cable model RC-2 (optional) for connection. No additional connection is required.

NOTE: While recording by connecting this REC/PB connector, the outputs of this connector are disconnected

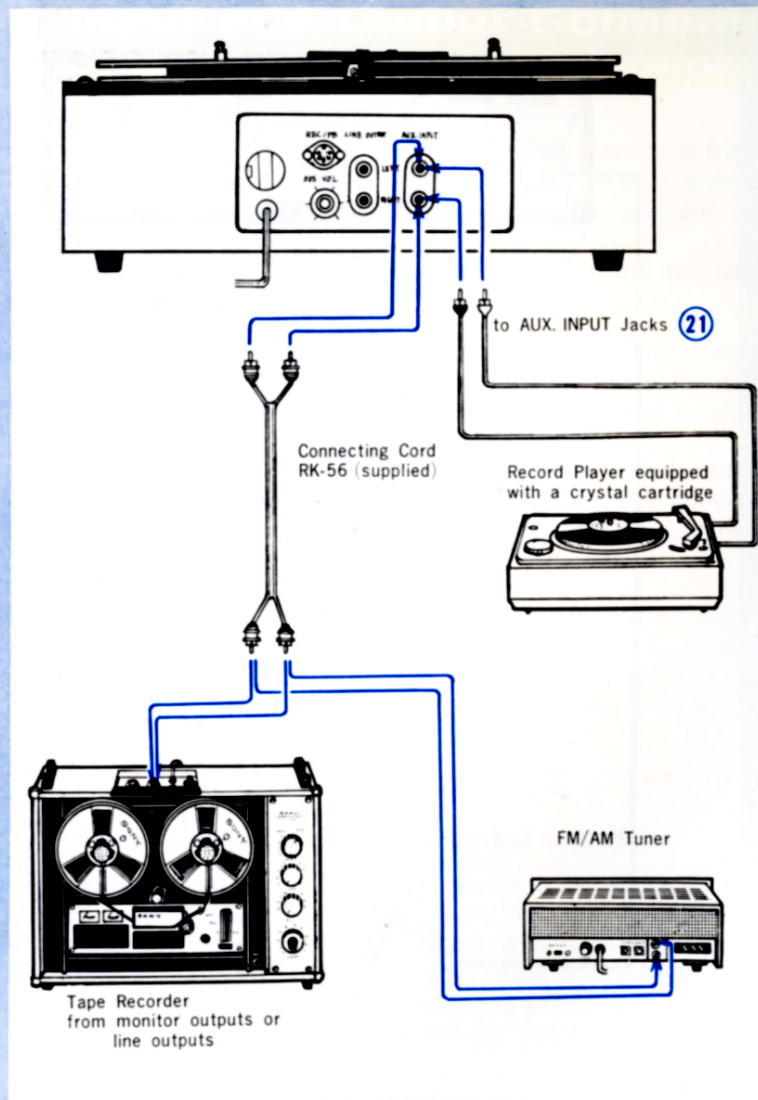

How to connect the recorder to an integrated amplifier

Connect left (CH-1) and right (CH-2) LINE OUTPUT JACKS **20** of the recorder to respective tape input jacks of an integrated amplifier (pre-amp/amplifier), using the supplied SONY Connecting Cord RK-56. Then, connect left (CH-1) and right (CH-2) AUXILIARY INPUT JACKS **21** of the recorder to respective tape output jacks of the integrated amplifier, using the other SONY Connecting Cord RK-56, which is also supplied with the recorder.

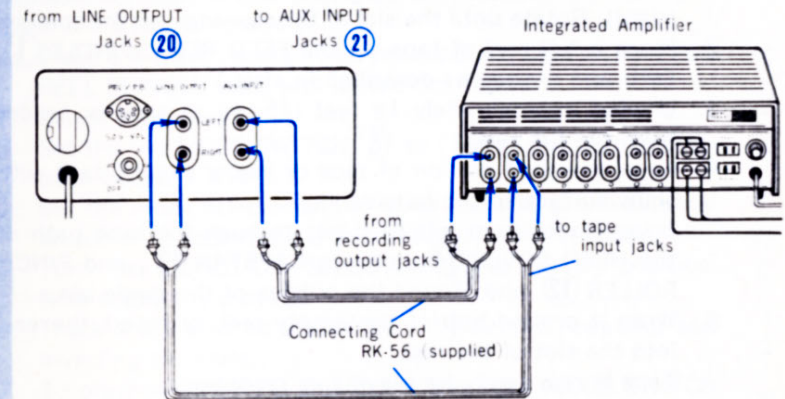

The 5 pin socket designated REC/PB **22** is used for the interconnection of the model 350 high level inputs and outputs with an integrated amplifier that incorporates a matching socket. A SONY REC/PB Connector Cable RC-2 is available as an optional accessory.

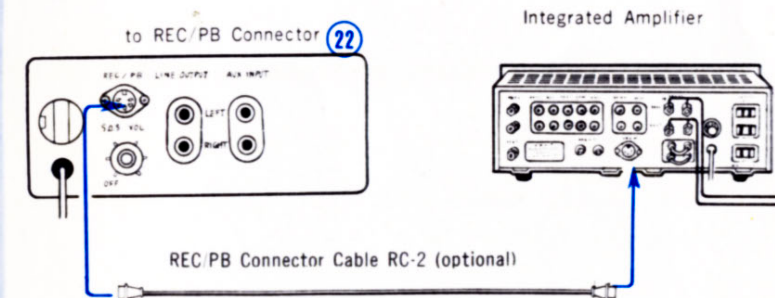

Threading Tape

Reel sizes from 3 to 7 inches in diameter are accommodated. Threading procedure is the same for all reel sizes.

1. Place an empty reel on the TAKE-UP REEL SPINDLE ⑮ (right). Rotate until the slot of the reel engages the spindle.
2. Place a full reel of tape on the FEED REEL SPINDLE ① (left) and engage as described in step 1.
3. Unwind approximately 1½ feet (45 cm) of tape or leader from the full reel.
4. Keep unwound portion of tape or leader slightly taut with shiny surface to the outside.
Bring leader from left to right; through the tape path of the HEAD COVER ⑭ between CAPSTAN ⑬, and PINCH ROLLER ⑫ and around the outside of the guide pin.
5. Wrap it around hub of the empty reel, or insert the end into the slot of the reel.
Tape is now ready for playing or recording.

NOTE: When the recorder is used in vertical position use rubber reel caps (supplied) to retain the reels on the recorder.

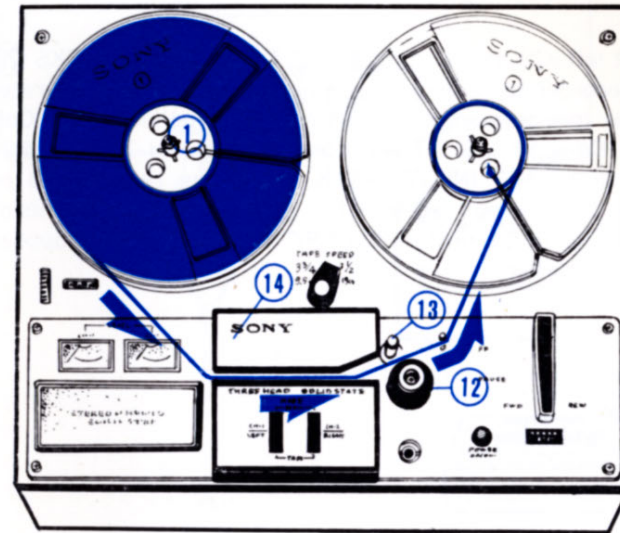

Playing Tapes

To Play Back 4-Track Stereo Tape

1. Place a 4-track pre-recorded tape with side 1 of the tape (tracks 1 and 3) up on the FEED REEL SPINDLE ① and thread the tape. (When the recorder is used in a vertical position, be sure to use both reel retaining caps. Do not use them when the recorder is in horizontal position.)
2. Select tape speed.
3. Set the MODE SWITCHES ⑧ to [TAPE] position.
4. Turn the FUNCTION SELECTOR ⑪ to [FWD] position.
Now the tracks 1 and 3 are playing.
(Playback output is obtained without passing through level control of the recorder.)
Adjustments for obtaining optimum volume level and sound quality should be performed by controls of the external integrated amplifier.
5. When the end of the tape is reached, do not rewind.
6. Invert and reverse the tape reels to playback tracks 4 and 2.
Place the full reel on the FEED REEL SPINDLE (left) and the empty reel on the TAKE-UP REEL SPINDLE (right).
7. Repeat operation step 4.

To Play Back 4-Track Monophonic Tape

The following playback procedure is recommended for a monophonic tape whose sequence of recording is; track 1—track 4—track 3—track 2.

1. Place a 4-track monophonic pre-recorded tape on the FEED REEL SPINDLE (left) and thread the tape.
2. Select tape speed.
3. Set the left MODE SWITCH ⑧ to [TAPE] position to playback tracks 1 and 4.
4. Set the mode selector and/or other controls of the external amplifier to reproduce the left channel (CH-1) sound.
5. Turn the FUNCTION SELECTOR ⑪ to [FWD] position.
Now track 1 is playing.
6. Track 4 will also be played back by simply reversing and inverting the reels.
7. To playback tracks 3 and 2, set the right MODE SWITCH ⑧ to [TAPE] position. Also set the mode selector and/or other controls of the external amplifier to reproduce right channel (CH-2) sound. Then turn the FUNCTION SELECTOR ⑪ to [FWD] position.

Recording

Before recording, try to estimate the input program playing time and provide more tape on the recorder than you think you will actually need.

NOTE: Be sure to check whether SOUND-ON-SOUND SWITCH/VOLUME CONTROL **18** marked [S.O.S. VOL] which is located on the back panel is in [OFF] position.

4-Track Stereo Recording

1. Thread the tape on the recorder.
2. Select the desired tape speed and reset the TAPE COUNTER **3**.
3. Switch the function selector of the connected external amplifier according to the desired input program source for recording.

*When the recorder is not connected to an integrated amplifier, connect stereo source to proper input jacks of the recorder. (See page 8, INPUT AND OUTPUT CONNECTORS.)

4. Set the MODE SWITCHES **8** to [SOURCE] position and adjust recording level by turning RECORD LEVEL CONTROLS **6**.
See VU METERS **4**.
5. Hold the RECORD BUTTON **7** in, turn FUNCTION SELECTOR **11** to [FWD] position. The RECORD BUTTON **7** is locked and recording on tracks 1 and 3 has started.
6. When the end of the tape is reached, do not rewind.
7. To record tracks 4 and 2, reverse and invert reels. Place the full reel on the FEED REEL SPINDLE **1** (left) and empty reel on the TAKE-UP REEL SPINDLE **15** (right).
8. Thread the tape again and repeat operation steps 4 and 5.

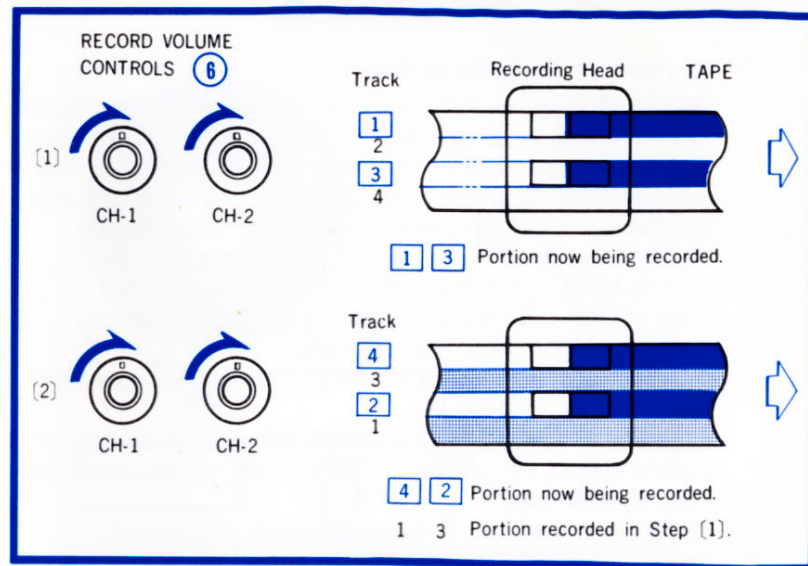

To Monitor While Recording

The professional feature of separate record and playback heads permits the monitoring of the recorded results while recording the same track (or tracks) by setting the MODE SWITCHES **8** to [TAPE] position.

When the external amplifier is equipped with a tape monitor switch, instantaneous comparison of the recordings and the recorded results is possible by turning on and off the tape monitor switch of the amplifier. In this case, the MODE SWITCHES **8** of the recorder should be in [TAPE] position.

Through the BINAURAL MONITOR JACK **9**, an instantaneous comparison of the recordings and the recorded results is possible by the setting the MODE SWITCHES **8** alternately to [TAPE] and [SOURCE] positions.

When the REC/PB connector **22** of the recorder is used and the recorder is set in RECORD mode, the instantaneous tape/source monitoring should be done through the BINAURAL MONITOR JACK **9**.

4-Track Monophonic Recording

1. Thread the tape on the recorder.
2. Select tape speed and reset the TAPE COUNTER **3**.
3. Switch the function selector of the external amplifier according to the desired input program source for recording.
 - *When the recorder is not connected to an external amplifier, connect the desired monophonic source to left channel (CH-1) input. (See page 8, INPUT AND OUTPUT CONNECTORS.)

Turn the right RECORD LEVEL CONTROL **6** fully counterclockwise to the [OFF] position until it clicks.

4. Set both MODE SWITCHES **8** to [SOURCE] position and adjust recording level by turning left RECORD LEVEL CONTROL **6**. See left VU METER **4**.
5. Hold the RECORD BUTTON **7** in, turn FUNCTION SELECT OR **11** to [FWD] position. The RECORD BUTTON **7** is locked and recording on track 1 has started.
6. When the end of the tape is reached, do not rewind.
7. Reverse and invert reels to record track 4. Place the full reel on the FEED REEL SPINDLE **1** (left) and the empty reel on the TAKE-UP REEL SPINDLE **15** (right).
8. To record tracks 3 and 2, turn left RECORD LEVEL CONTROL **6** fully counterclockwise to the [OFF] position until it clicks. Be sure to check whether the right MODE SWITCH **8** is set in the [SOURCE] position. Adjust recording level by the right RECORD LEVEL CONTROL **6** and right VU METER **4**.
9. Repeat operation steps 5, 6 and 7.

Playback sequence of each track should conform to the sequence of recording, i.e.

- track 1 left channel (CH-1)
- track 4
- track 3 right channel (CH-2)
- track 2

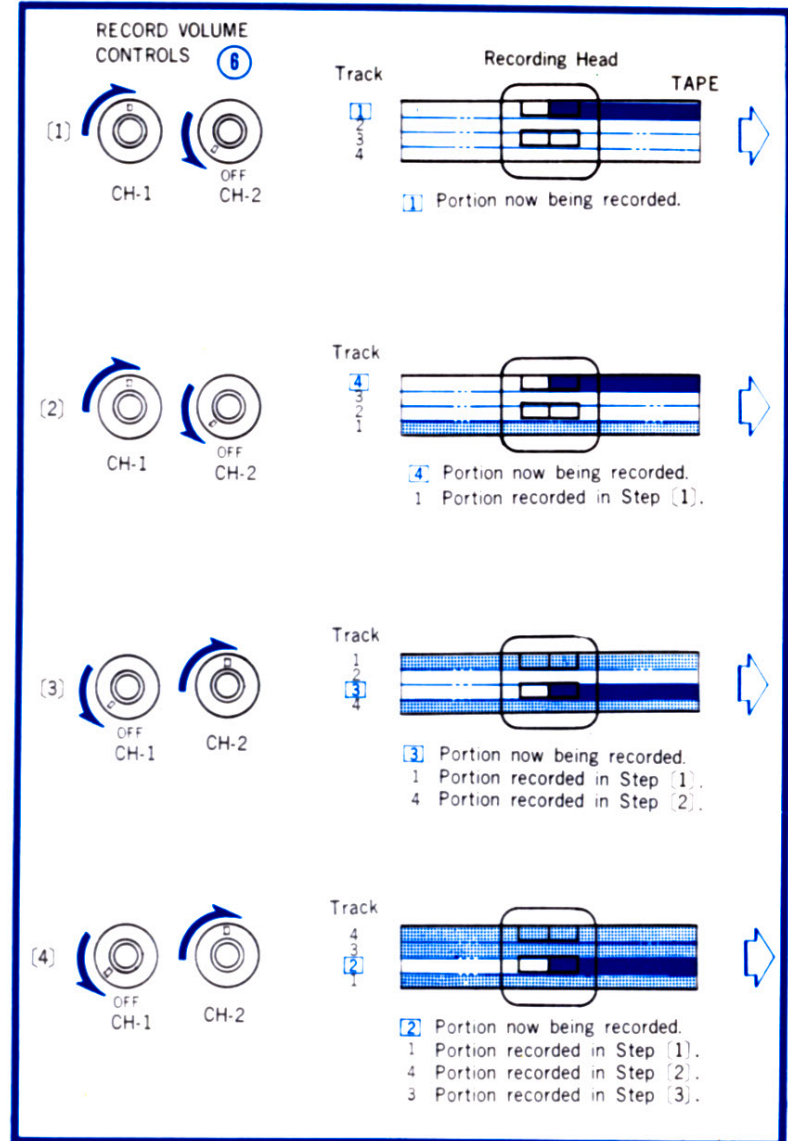

Erasing Tape

When the recorder is set in the record mode, the Erase Head will erase the track (or tracks) of the tape for the corresponding traces of the recording head. Therefore, when you start a new recording, any previous recordings are automatically erased as the tape passes the erase head.

You can also erase a tape without adding a new recording. Simply place the recorder in record mode by turning left (CH-1) and right (CH-2) RECORD LEVEL CONTROLS ⑥ fully counter-clockwise (but not turn off) and run the tape through. The tape will be erased more quickly by using a bulk eraser.

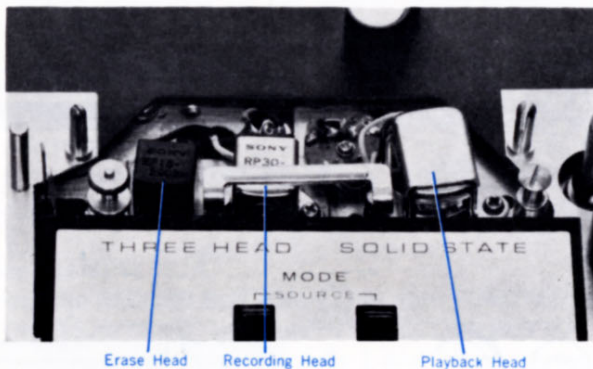

Splicing Tape

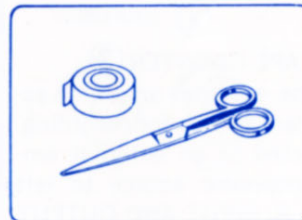

1. Use splicing tape and a pair of scissors.

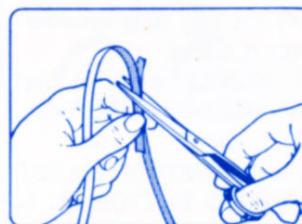

2. Overlap the recording tapes and make a diagonal cut across both tapes.

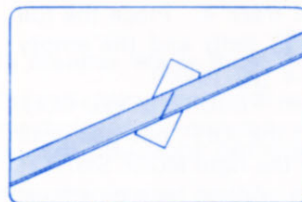

3. Carefully align and butt the cut ends together. Keep the ends in contact, firmly press a piece of splicing tape over the shiny side of the tape to make a firm joint.



4. Trim off the excess splicing tape.

Sound-on-Sound Recording

This recorder is equipped to produce high quality professional 'sound-on-sound' composite recordings. A small amount of practice with the following procedures will enable you to become expert in the many fascinating uses of 'sound-on-sound' recordings.

Recording basic source material

1. Record basic source material on track 1 of the left channel (CH-1), as outlined under 4-track monophonic recording on page 15, and rewind the tape back to the beginning.

Recording composite information

2. Turn off the left (CH-1) RECORD LEVEL CONTROL (6) and set left (CH-1) MODE SWITCH (8) to [TAPE] position.

3. Turn on the SOUND-ON-SOUND SWITCH/VOLUME CONTROL (18) located at the rear side.
4. Plug in the right (CH-2) MICROPHONE INPUT (5).
5. Plug in high impedance headset to BINAURAL MONITOR JACK (9).
6. Listening through the headset, adjust and balance the recording level by rotating SOUND-ON-SOUND SWITCH/VOLUME CONTROL (18) and right (CH-2) RECORD LEVEL CONTROL (6).

NOTE: From the left (CH-1) headset, the playback of left channel (CH-1) is heard and from the right (CH-2) headset, the recorded results of the composite recordings is heard when the MODE SWITCHES (8) are set in [TAPE] position.

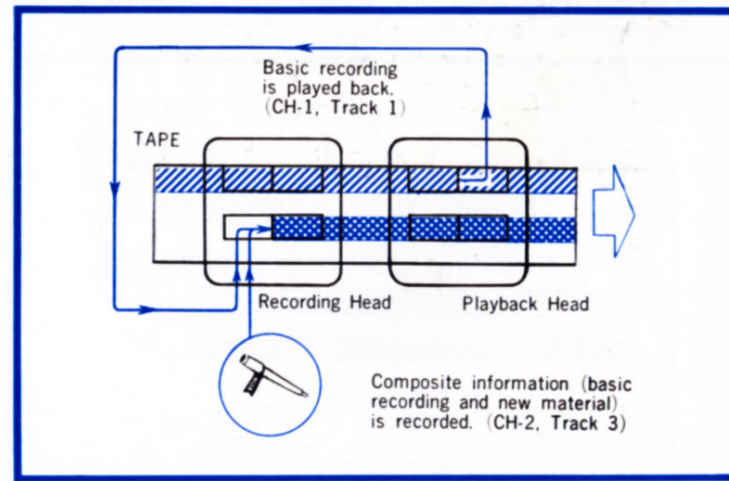
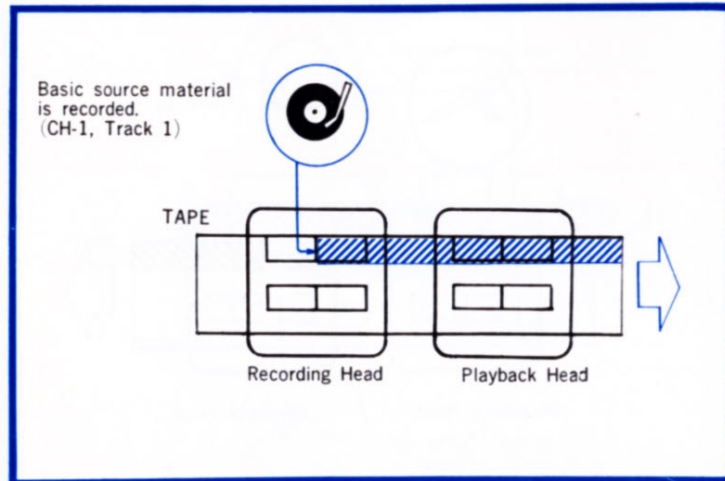

Tape Teaching

Left (CH-1) VU METER shows the playback level of the basic source material.

Right (CH-2) VU METER shows the level of the composite recordings being made.

A certain amount settings will insure both signals of the composite track being recorded in desired ratio.

7. When the end of the tape is reached, the composite information will have been recorded on track 3 of right (CH-2) channel.

NOTE: Sound-on-sound recording is possible only from left channel (CH-1) to right channel (CH-2).

8. Be sure to turn OFF the SOUND-ON-SOUND SWITCH/ VOLUME CONTROL **18** when the composite recording is completed.

Playback

9. Rewind the tape back to the beginning and playback recordings on track 3 as outlined under 'To playback 4-track monophonic tape' on page 13.

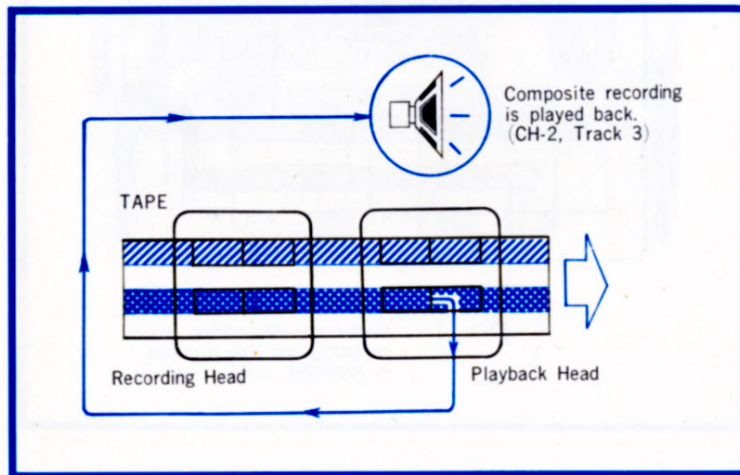

- This recorder provides facilities to play back one track while the other track is being recorded. This exclusive feature is ideal for language students who wish to listen to a pre-recorded lesson on one track while recording the answers or repetitions on the other track. Both tracks can later be played back separately or simultaneously for comparison.

Master recording

1. Record teacher's program on track 1 (left channel, CH-1) according to 4-track monophonic recording on page 15, and rewind the tape back to the beginning.

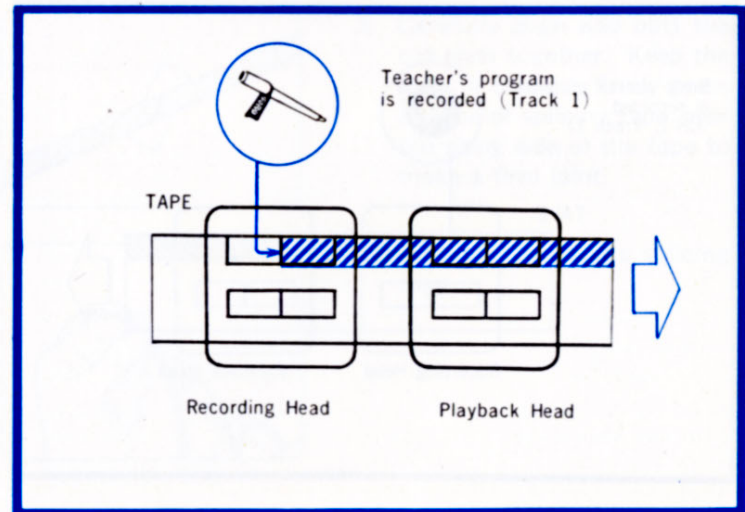

Practice recording

2. Turn OFF the left (CH-1) RECORD LEVEL CONTROL ⑥ and set the left (CH-1) MODE SWITCH ⑧ to [TAPE] position.
3. Connect the headset to the BINAURAL MONITOR JACK ⑨.
4. Connect the microphone to the right (CH-2) MICROPHONE INPUT JACK ⑤.
5. Turn ON the right (CH-2) RECORD LEVEL CONTROL ⑥ and record your practice recordings on track 3 (right channel, (CH-2) by repeating or answering the master recording which is heard through the headset.

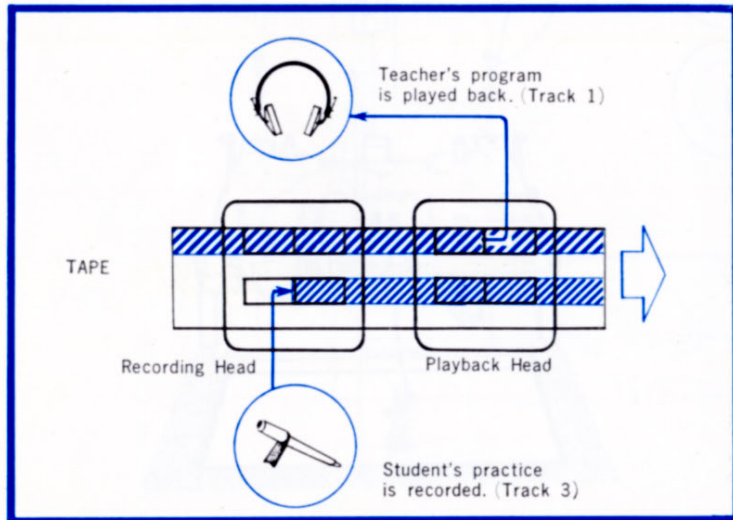

Simultaneous playback

6. Rewind and playback the tape in the same manner as a stereo tape; then, the master track and the practice track are simultaneously reproduced.

In the above method, the master and the practice recordings are made separately on different channels, so that the practice track can be repeatedly recorded without erasing the master track.

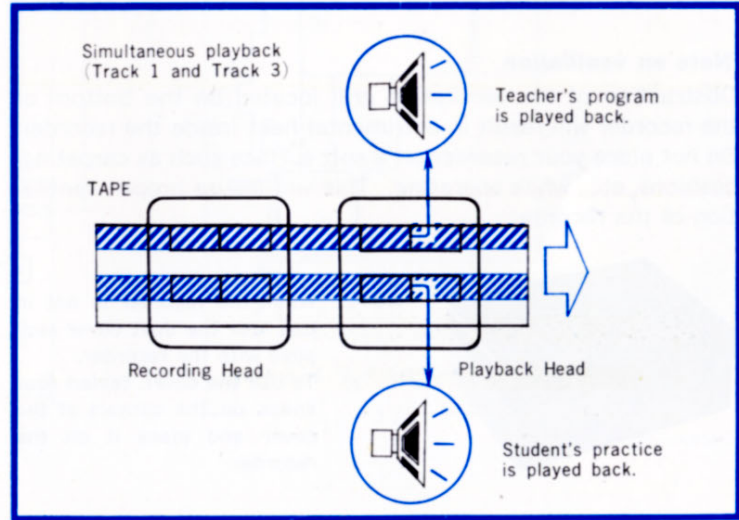

How to Mount Model TC-350

The model TC-350 can be installed in either horizontal or vertical position.

1. Cut hole of $15 \times 11\frac{1}{2}$ " (380×292 mm) in desired mounting location.
2. Remove FUNCTION SELECTOR knob, TAPE SPEED SELECTOR knob, HEAD COVER, RECORD LEVEL CONTROL knobs, PINCH ROLLER and five Philips mounting screws from the top panel and lift up the panel.
3. Remove deck from wooden base by unscrewing (turn counterclockwise) four rubber bases and a screw from the bottom of the wooden base.
4. Mount deck in new location and fasten with three wood screws (supplied).
5. Place the top panel on top of the deck and replace the parts removed in Step 2.

Note on ventilation

Obstruction of the ventilation grill located on the bottom of the recorder will result in detrimental heat inside the recorder. Do not place your recorder on a soft surface such as carpeting, cushions, etc., while operating. This will insure proper ventilation of the recorder.



NOTE: When the recorder is not in use, use the dust cover supplied with the recorder. To use the cover, fasten four snaps on the corners of the cover and place it on the recorder.

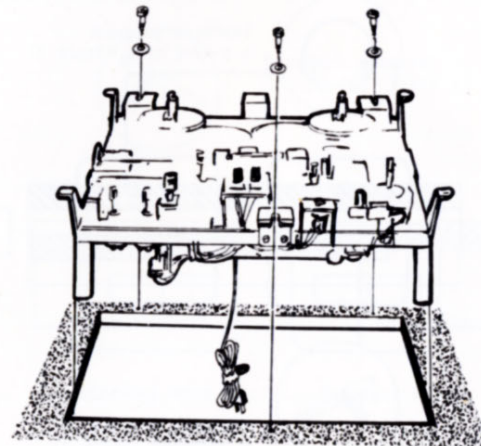
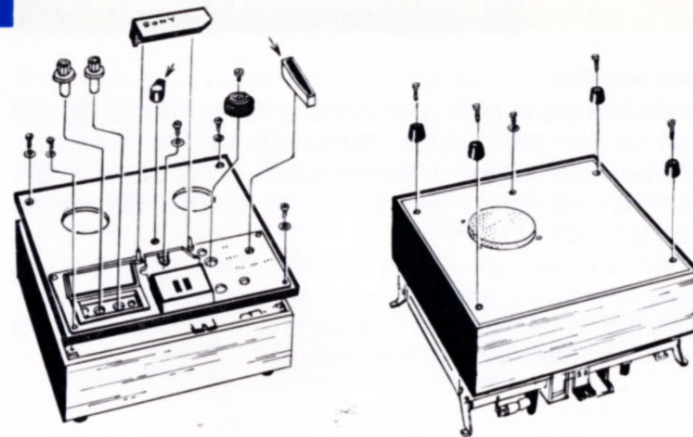

Mounting Dimensions

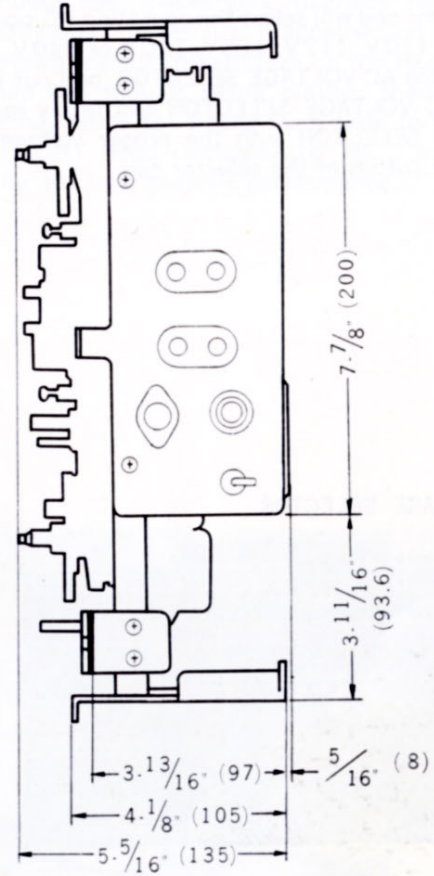
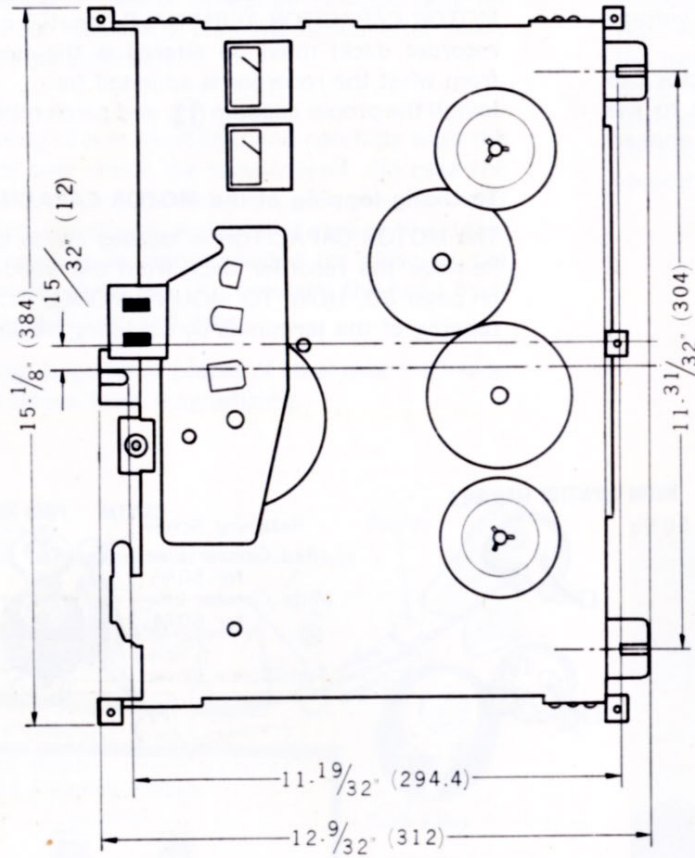

(millimeter)

Adaptation to the Local Power Line

To set operating voltage

The AC VOLTAGE SELECTOR (17) is located at the rear side of the recorder and will select the operating AC power line voltage of 100V, 110V, 117V, 125V, 220V or 240V.

To reset the AC VOLTAGE SELECTOR, pull out the selector cap of the AC VOLTAGE SELECTOR and firmly re-insert it to the VOLTAGE SELECTOR with the proper voltage figure appearing in the cutout of the selector cap.

AC VOLTAGE SELECTOR

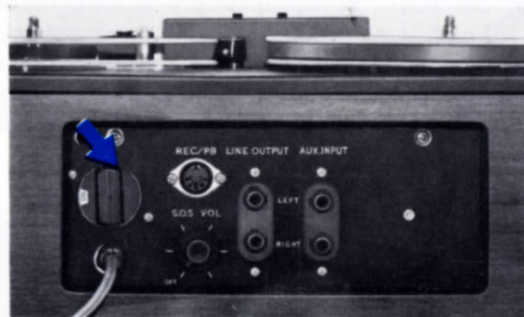

AC frequency requirement

The PINCH ROLLER (12), CAPSTAN (13) and tapping of the MOTOR CAPACITOR TERMINALS (located on the bottom of the recorder deck) must be altered if the line frequency differs from what the recorder is adjusted for.

Install the proper capstan (13) and pinch roller (12) as illustrated.

To change tapping of the MOTOR CAPACITOR TERMINALS

The MOTOR CAPACITOR is located inside the recorder. Remove the recorder deck from the wooden base as outlined on page 20, HOW TO MOUNT MODEL TC-350. Change the tapping of the terminals by soldering as illustrated.

MOTOR CAPACITOR TERMINALS

50 c/s



60 c/s

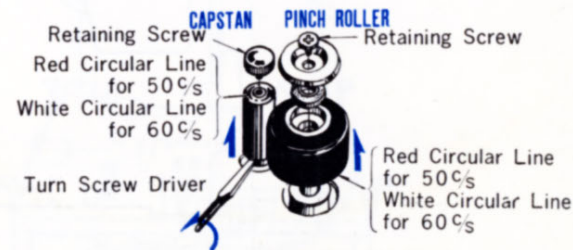

Maintenance

Cleaning heads

Intimate contact between heads and tape is important for optimum performance. Generally, cleaning heads after every ten hours of use will be sufficient.

TO CLEAN

Take the head cleaning ribbon (supplied) and carefully wipe the portion of the heads over which the tape travels. (In case the deposits on the head cannot be removed, dampen the head cleaning ribbon with denatured alcohol and repeat the cleaning.) The same procedure is recommended for cleaning the capstan and pinch roller surfaces. This prevents the head from oxide deposits causing flutter and wow.

NOTE: Do not bring magnets or pieces of steel near the heads to prevent heads from magnetizing.

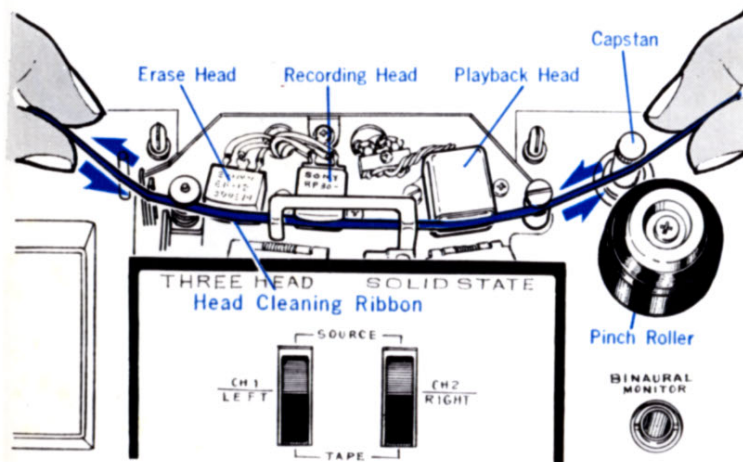

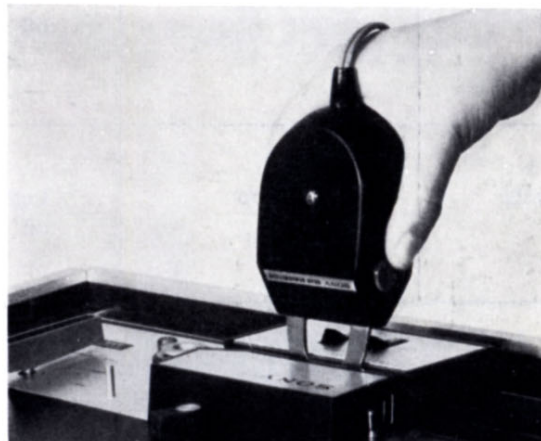

Demagnetizing heads

Through continuous use, the varying magnetic fields of the tape will gradually build up residual magnetism on the gap of the head. Excessive residual magnetism on the head will produce noise while the tape is being played; therefore it is advisable to demagnetize the heads from time to time. The periodic use of SONY Head Demagnetizer HE-2 (optional) is recommended for the best possible performance.

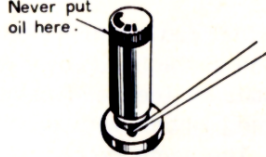
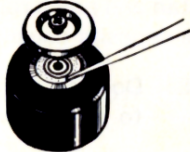

Lubrication chart

Parts to lubricate	Quantity of oil every 6 months	Type of oil	Remarks	Figures
Capstan bearings	3 drops	Light machine oil	Don't stain capstan surface	 <p>Never put oil here.</p>
Pinch roller bearings	1 drop	Light machine oil	Don't stain rubber surface	
Idler shafts	1 drop	Light machine oil	Remove top cover panel to gain access (see page 20)	
Reel shafts	1 drop	Light machine oil		

- NOTE: (1) Avoid excessive lubrication. It will cause slippage in the mechanism and contamination of your tape.
 (2) If stalling occurs in FAST FORWARD motion, clean each rubber idler wheel under the top panel with a soft cloth moistened with denatured alcohol.

Schematic Diagram

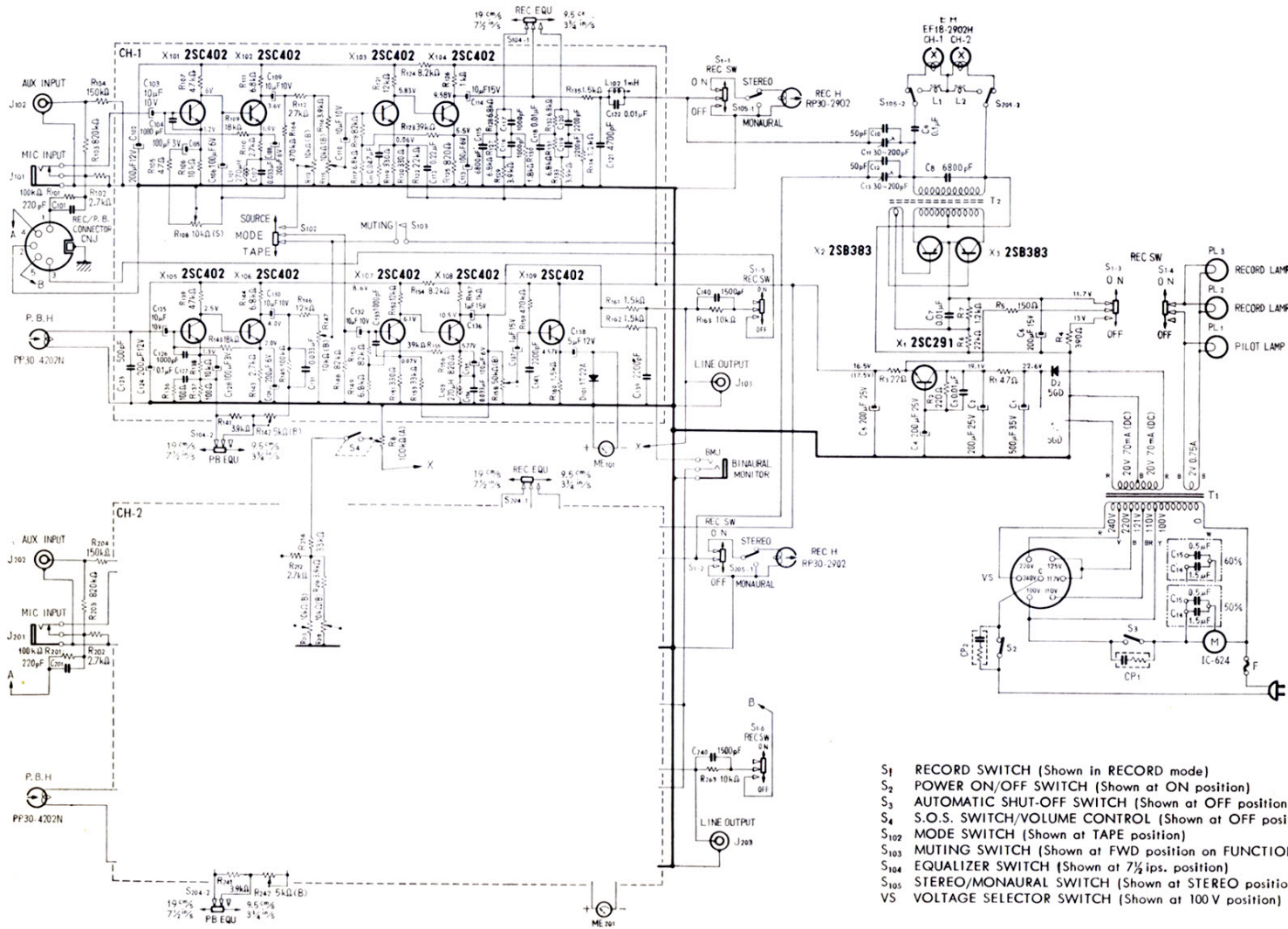

- S1 RECORD SWITCH (Shown in RECORD mode)
- S2 POWER ON/OFF SWITCH (Shown at ON position)
- S3 AUTOMATIC SHUT-OFF SWITCH (Shown at OFF position)
- S4 S.O.S. SWITCH/VOLUME CONTROL (Shown at OFF position)
- S102 MODE SWITCH (Shown at TAPE position)
- S103 MUTING SWITCH (Shown at FWD position on FUNCTION SELECTOR)
- S104 EQUALIZER SWITCH (Shown at 7 1/2 ips. position)
- S105 STEREO/MONAUURAL SWITCH (Shown at STEREO position)
- VS VOLTAGE SELECTOR SWITCH (Shown at 100 V position)

Recommended Accessories

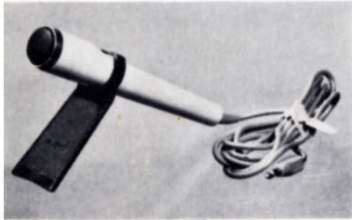

Microphone F-96

A wide range, general purpose, omni-directional dynamic microphone of low impedance (600 ohms).



Stereo Headset DR-3C

High quality dynamic headset of high impedance (10K ohms) with a standard phone plug for private stereo listening or monitoring while recording.

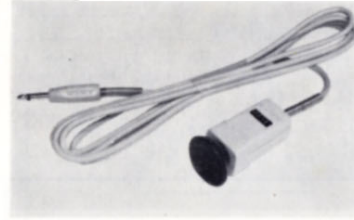

Telephone Pick-up TP-4S

For recording of telephone conversation on tape.

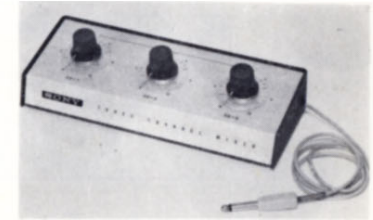

Microphone Mixer MX-600

3-channel, 600 ohms MIC and/or LINE INPUT mixer with independent volume control for each channel.

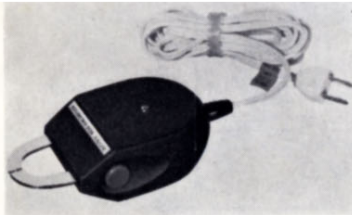

Head Demagnetizer HE-2

For quick and easy demagnetizing of the magnetic heads to keep the recorder in the best reproducing condition.

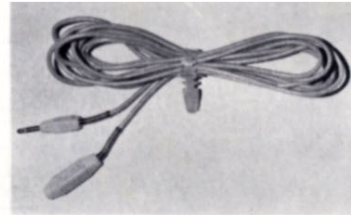

Microphone Extension Cords EC-5M, -10M, -25M

EC-5M (approx. 16 feet, 5 meter long), EC-10M (approx. 33 feet, 10 meter long), EC-25M (approx. 82 feet, 25 meter long) series of microphone cords for extension of microphone.

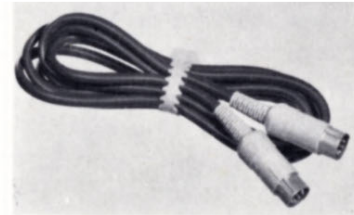

REC/PB Connector Cable RC-2

Connector cable with 5-pin connector for recording from or reproducing through an integrated amplifier (pre-amp/amplifier).

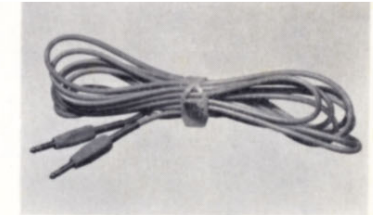

Connecting Cord RK-34

Approx. 10 feet (3 meter) long cord with mini-plug on both ends.

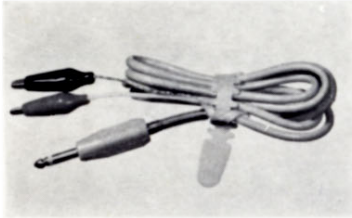

Connecting Cord RK-36

Approx. 3 feet (1 meter) long cord with mini-plug on one end and alligator clips on the other end.

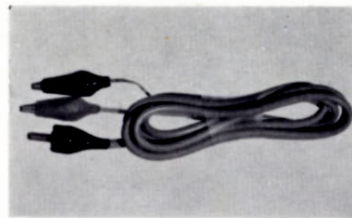

Connecting Cord RK-46

Approx. 3 feet (1 meter) long cord with phono-plug on one end and alligator clips on the other end.

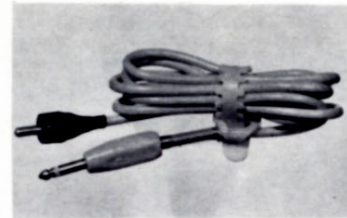

Connecting Cord RK-50

Approx. 3 feet long (1 meter) long cord with phono-plug on one end and mini-plug on the other end.

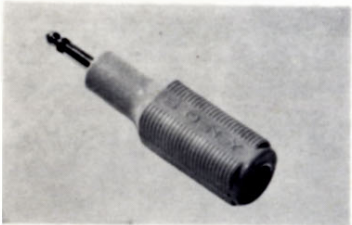

Plug Adaptor PC-1

Adapts standard phone plug connectors to fit mini jacks.

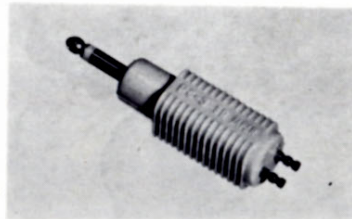

Plug Adaptor PC-3

Incorporates 8 ohm resistor. For recording from external speaker jack of a tape recorder or from an earphone jack of a transistor radio. Fits mini jacks.



Plug Adaptor PC-5

Adapts mini-plug connectors to fit phono jacks.

