

# Programmable AM/FM Scanning Receiver

with Direct Keyboard Entry System

VHF: 30-50/108-136/138-174 MHz UHF: 410-512 MHz



**PRO-2002**

**OWNER'S  
MANUAL**

**REALISTIC®**

**CAT. NO.  
20-116**

CUSTOM MANUFACTURED FOR RADIO SHACK  A DIVISION OF TANDY CORPORATION

## TABLE OF CONTENTS

Features Include . . . . .	2
Specifications . . . . .	3
A Quick Look At Your PRO-2002 . . . . .	4
Preparation For Use . . . . .	5
Operating Your PRO-2002 . . . . .	5
Receiver Operations Display . . . . .	5~8
Searching With Your PRO-2002 . . . . .	8
Error Indications . . . . .	9
Setting The Clock . . . . .	9
Birdies . . . . .	10
Mobile Installation . . . . .	10
Mobile Noise Suppretion . . . . .	11
Before Using Your PRO-2002 Mobile.. . . .	12
Guide To The Action Bands . . . . .	12
Typical Band Usage . . . . .	13
Some Random Notes . . . . .	14
Befor You Call For Help... . . . .	15
Block Diagram . . . . .	16

You'll hear all the action with your new Realistic PRO-2002 Programmable Scanning Receiver! You'll have direct access to 20,480 different frequencies in seven action radio bands—police, fire, ambulances, aircraft, ham radio operators and transportation services! And you can program your PRO-2002 to scan up to fifty channels so you won't miss any of the excitement.

The secret to the PRO-2002 is a custom-designed microprocessor—a computer on a chip! The front panel Keyboard lets you easily enter and change frequencies whenever you wish. The microprocessor also gives you special functions not found on other scanning receivers. Curious about what's on the air in your area? The PRO-2002 will automatically "search" frequency ranges of your choice for active stations—you can locate new stations and services easily! And if there's a frequency you're especially interested in, the PRIORITY Key will make sure you never miss a call on it. You can listen or scan other channels and your PRO-2002 will automatically switch to the channel when a call is received on it!

Other features you'll appreciate include Lockout to skip over channels during scanning and fast/slow search and scanning rates. And there's a handy built-in clock as well.

Your PRO-2002 achieves its superior performance through the use of the very latest in solid-state technology. In addition to the microprocessor, the PRO-2002 includes a phase-locked loop (PLL) IC, 9 CMOS ICs, 13 integrated circuits, 44 transistors, 75 diodes and a Fluorescent Display.

## FEATURES INCLUDE:

- \* Covers 30–50 MHz (VHF Lo), 108–136 MHz (aircraft), 138–144 MHz (government), 144–148 MHz (ham radio operators), 148–174 MHz (VHF Hi), 410–450 MHz (ham radio and government), 450–470 MHz (UHF Lo) and 470–512 MHz (UHF Hi)—**20,480 channels!**
- \* Scans up to 50 channels continuously.
- \* Search feature scans frequency ranges for new stations.
- \* Priority function means you'll never miss a call on your favorite channel!
- \* Large multi-purpose Fluorescent Display shows which channels and frequencies are being scanned, monitored or programmed as well as displaying time from the built-in clock.
- \* Channel Lockout function with built-in skipper circuit.
- \* Three second scan delay function eliminates missed replies.
- \* Crystal filter for 1st IF (10.7 MHz) plus ceramic filter for 2nd IF (455 kHz).
- \* AC and DC (negative ground) operation.
- \* Universal mounting bracket.
- \* 9-volt battery backup holds memorized frequencies and clock in case of power failure.

**RADIO SHACK LIMITED WARRANTY**

This equipment is warranted against defects for 1 year from date of purchase. Within this period, we will repair it without charge for parts and labor. Simply **bring your sales slip** as proof of purchase date to any Radio Shack store. Warranty does not cover transportation costs. Nor does it cover equipment subjected to misuse or accidental damage.

This Warranty gives you specific legal rights and you may also have other rights which vary from state to state.

*We Service What We Sell*

For Your own protection, we urge you to record the Serial Number of this unit in the space provided. You'll find the Serial Number on the back panel of this unit.

Serial Number

**WARNING: TO PREVENT FIRE OR SHOCK HAZARD, DO NOT EXPOSE THIS RECEIVER TO RAIN OR MOISTURE.**

## SPECIFICATIONS

<b>SEMICONDUCTOR COMPONENTS:</b>	1 LSI Microprocessor system, 1 LSI PLL system, 9 C-MOS ICs, 13 ICs, 44 transistors and 75 diodes	<b>SELECTIVITY:</b>	±9 kHz, -6 dB ±15 kHz, -50 dB
<b>RECEIVING SYSTEM:</b>	Superheterodyne with digital synthesizer to receive any of 20,480 programmable frequencies.	<b>IF REJECTION:</b>	10.7 MHz      80 dB at 154 MHz
<b>FREQUENCY COVERAGE:</b>	VHF-Lo 30 - 50 MHz (in 5 kHz steps) Aircraft 108 - 136 MHz (in 25 kHz steps) Government 138 - 144 MHz (in 5 kHz steps) Ham 144 - 148 MHz (in 5 kHz steps) VHF-Hi 148 - 174 MHz (in 5 kHz steps) Ham/Gov't. 410 - 450 MHz (in 12.5 kHz steps) UHF-Lo 450 - 470 MHz (in 12.5 kHz steps) UHF-Hi ("T") 470 - 512 MHz (in 12.5 kHz steps)	<b>SCANNING RATE:</b>	Fast      6 channels/sec. Slow      3 channels/sec.
<b>CHANNELS OF OPERATION:</b>	Any 50 channels in any band combinations. (10 channels x 5 Banks)	<b>SEARCH RATE:</b>	Fast      8 steps/sec. Slow      3 steps/sec.
<b>SENSITIVITY</b>		<b>PRIORITY SAMPLING:</b>	3 seconds 100 milli seconds
<b>AM: 10 dB Signal-to-Noise ratio at 60% modulation:</b>	108 - 136 MHz    1.0 μV	<b>DELAY TIME:</b>	3 seconds
<b>FM: 20 dB Signal-to-Noise ratio at 3 kHz Deviation:</b>	30 - 50 MHz      0.5 μV 138 - 174 MHz    0.5 μV 410 - 512 MHz    1.0 μV	<b>MODULATION ACCEPTANCE:</b>	±7 kHz
<b>SPURIOUS REJECTION:</b>	108 - 136 MHz    50 dB at 122 MHz 30 - 50 MHz      50 dB at 40 MHz 138 - 174 MHz    50 dB at 160 MHz 410 - 512 MHz    Not specified.	<b>I.F. FREQUENCIES:</b>	10.7 MHz and 455 kHz
		<b>FILTERS:</b>	1 crystal filter, 1 ceramic filter
		<b>SQUELCH SENSITIVITY:</b>	Threshold      Less than 1.0 μV Tight            (S+N/N) 25 dB
		<b>ANTENNA IMPEDANCE:</b>	50 ohms
		<b>AUDIO POWER:</b>	2 watts maximum
		<b>BUILT-IN SPEAKER:</b>	2½" x 4 (6.5 x 10 cm) oval
		<b>POWER REQUIREMENTS:</b>	AC, 120 Volts, 60 Hz, 19 watts DC, 12-15 Volts, 10 watts 9-volt battery for Memory back-up
		<b>DIMENSIONS:</b>	3-1/8" x 10-1/4" x 10-5/8" HWD (8 x 26 x 27 cm)
		<b>WEIGHT:</b>	7.7 lbs (3.5 kg)

## A QUICK LOOK AT YOUR PRO-2002

**Bank Keys** — Selects search and scan memory banks.

**Multi-purpose Display** — Shows which channel and frequency are being scanned, monitored or programmed, as well as time.

**OFF/VOLUME Control** — Turn clockwise for power "on". Further rotation will increase volume.

**SQUELCH Control** — Eliminates background noise between transmissions. With no signal, turn clockwise until noise disappears.

**Telescopic Antenna Jack** — When not using an external antenna, insert the Telescopic Antenna (included) into the hole and screw it into place.

**ANTENNA Jack** — For superior reception, connect an outdoor antenna to this jack.

**TAPE OUT Jack** — You can connect a tape recorder directly to this jack.

**EXT. SPKR Jack** — For connecting an external speaker.

**MANUAL Key** — Sets the PRO-2002 to manually scan the channels. Each time the button is pressed, the Receiver will advance one channel.

**PRIORITY Key** — Sets or clears priority function.

**SCAN Key** — Sets the PRO-2002 to automatically scan each available channel.

**▲ ▼ and LIMIT Keys** — Commands search direction, and search range limit.

**Number Keys** — Enter the desired channel number and its frequency.

**0/PM Key** — Enter zero (0) or set clock to PM.

**CLEAR Key** — Clears the display when an error is made in programming.

**ENTER Key** — Enters a displayed frequency into any one of the 50 channels you may select.

**PROGRAM Key** — Sets the internal microprocessor for entry of a frequency.

**•/AM Key** — Places the decimal point or sets clock to AM.

**CLOCK Key** — Push to set time and turn the time display ON or OFF.

**SPEED Key** — Selects scan and search speeds: fast (6 ch/sec) or slow (3 ch/sec).

**DC 13.8V Jack and Cable** — is for connecting an external source of 12 volts DC, negative ground. Connect brown ⊕ lead to accessory terminal, and red ⊕ lead to +12V always alive.

**GND ⊖** — Screw black ⊖ lead and connect it to negative ground.

**AC Line Cord** — Plug into a source of 120 volts, 60 Hz, AC power.

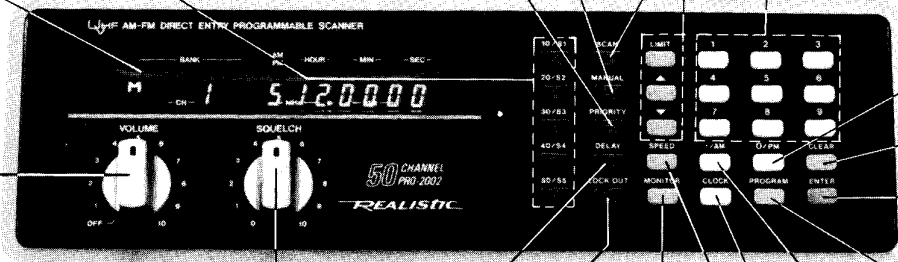

**DELAY Key** — Holds the Receiver on the channel for three seconds after the transmission has ended.

**LOCKOUT Key** — Enables you to lockout (disable) desired channels. Press once to lockout. Press again to return channel to normal operation.

**MONITOR Key** — Press to store frequencies found during search mode.

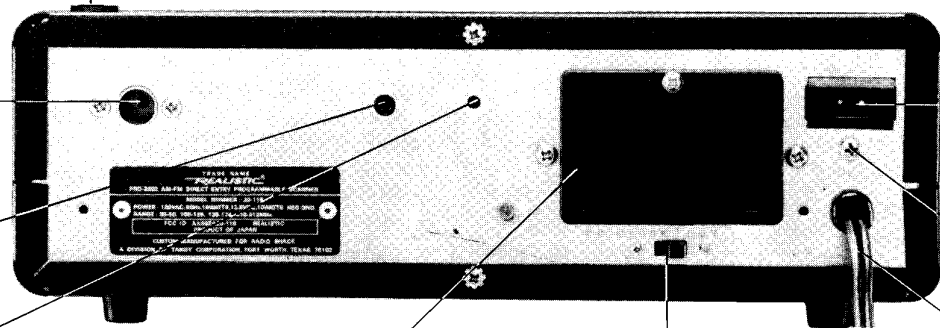

**Battery Compartment** — Load a 9-volt battery here to prevent loss of programmed frequencies when the Receiver is unplugged.

**DC CLOCK/OUT SWITCH** — When using mobile, set to OUT position when your vehicle is going to be parked for several days. This conserve battery life.

## PREPARATION FOR USE

Loosen the screw and remove the battery compartment cover; then snap in a 9-volt battery. (We recommend a Radio Shack long-life alkaline battery, 23-553 or equivalent.) Your PRO-2002 contains an electronic memory to preserve the 50 programmed scanner channels. The battery protects this memory during AC or DC power failure, or when you have the set unplugged.

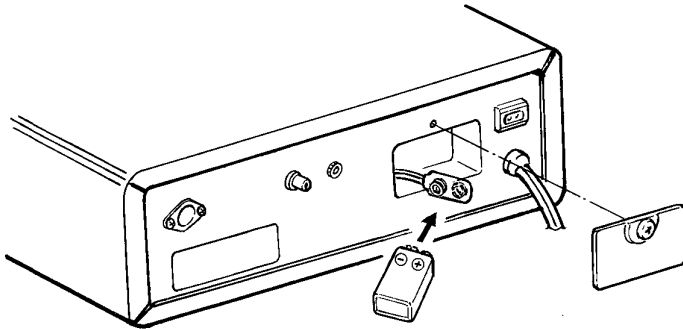

Your PRO-2002 can keep channels stored in its memory for a short period of time even with the AC cord unplugged and the 9-volt battery disconnected. (This is so you can replace the battery with the AC cord unplugged, without losing all the programmed information.) For best results, replace the battery every six months.

**CAUTION:** Never leave a weak or dead battery in your PRO-2002; even "leakproof" types can leak damaging chemicals. Battery life is about one month when AC or DC power is off for a prolonged period.

Your PRO-2002 comes with a Telescopic Antenna. Insert into the Telescopic Antenna jack on the top of your PRO-2002 and screw into place. Extend to its full length.

For very best reception, you'll need an external antenna. Your local Radio Shack has an excellent antenna for both VHF and UHF reception (Cat. No. 20-176). You can also find mounting hardware, cables and connectors from Radio Shack too. You'll find that reception improves the higher you mount the antenna.

Connect your Receiver to a standard 120 volt AC wall outlet. When you first plug in your PRO-2002, you might notice that the Display in flashing on and off. **Don't be alarmed—this is normal!** To stop the Display from flashing, just press the CLOCK Key.

## OPERATING YOUR PRO-2002

You turn on your PRO-2002 by rotating VOLUME clockwise. (when first turned on, your PRO-2002 may start scanning.)

Rotate SQUELCH fully counterclockwise. You'll hear a rushing noise from the Speaker. Slowly rotate SQUELCH clockwise until the noise just stops. You're now ready to start entering frequencies!

## Understanding the Display

The Fluorescent Display on your PRO-2002 can display the time, channel number, the frequency being received and special symbols to indicate different functions. Here's a brief rundown on what those symbols mean when receiving stations (we'll cover the Clock symbols later. . . .):

## RECEIVER OPERATIONS DISPLAY

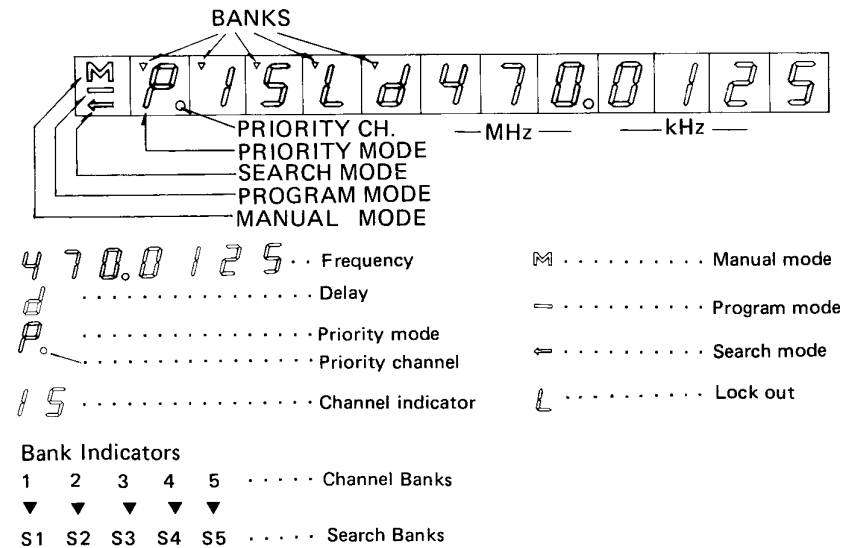

## About Those Banks . . .

You might be wondering what the “bank indicators” on the Fluorescent Display stand for. When you hear the word “bank” you think of a place where money is kept . . . in your PRO-2002 “banks” are where frequencies are kept!

The fifty channels of your PRO-2002 are stored in five Banks of ten channels each. They’re stored in the following way:

Bank	Channels
1	1 – 10
2	11 – 20
3	21 – 30
4	31 – 40
5	41 – 50

You can have your PRO-2002 scan any or all of the five Banks. If you want a bank to be scanned, just press the Key for that Bank. If you don’t want that bank to be scanned, just press the Key again.

Let’s take an example. Suppose you only want to monitor channels 1 through 10 and 21 through 30. Press the Keys for Banks 1 and 3. You’ll see the Bank Indicators light up on the Display as shown in the illustration. Your PRO-2002 will now scan channels 1 to 10 and 21 to 30. If you want to change the channels scanned, just press the Keys for Banks 1 and 3 (to turn them “off”) and press the Keys for the new ranges you want to scan.

You’ll also use these Banks to store a range for the Search function. You can store one Search range in each Bank (for a total of five Search ranges). We’ll talk about these later when we describe the Search function in detail.

## Programming Frequencies

Before programming frequencies, make sure your PRO-2002 is turned on and the SQUELCH is adjusted as we described earlier.

Suppose you want to program channel 1 to receive 162.55 MHz. Here’s how you would do it:

1. Press **MANUAL** and select channel 1. You can do this in two ways: press **MANUAL** continuously until the Display indicates channel 1 or by pressing **1** **MANUAL** .
2. Press **PROGRAM** Key.
3. Press the **1** **6** **2** **•/AM** **5** **5** Keys. Check the Display to make sure the frequency it shows is the one you meant to program. If it is, press the **ENTER** Key.
4. To add more frequencies, just press **PROGRAM** to advance to the next channel and follow the steps above.
5. If you ever want to change the frequency entered for a specific channel, just enter the new frequency “over” the old frequency using steps 1, 2 and 3.

Make a mistake while entering a frequency? Just press **CLEAR** , enter the correct frequency and press **ENTER** . If you’re entering a new frequency in place of an old one, the old frequency won’t be “erased” when you press **CLEAR** . It will remain stored on that channel until you correctly enter a new frequency and press **ENTER** .

You’ll hear a “peep” sound as you press the various keys. This lets you know the Key has been properly “entered” into your PRO-2002.

## Using the Scanning Function

Your PRO-2002 will automatically scan all the channels you've programmed and stop whenever it finds a signal. To scan channels, just press the **[SCAN]** Key.

*Important!* Your PRO-2002 won't scan unless SQUELCH is set to the point where no sound is heard if a signal isn't being received.

You can select which of the five Banks your PRO-2002 will scan by pressing the appropriate Bank Keys as we mentioned earlier. You can scan any combination of Banks from just one to all five. You can't "turn off" all the Banks; if you try to do so, Bank 1 will automatically "turn on" and your PRO-2002 will scan channels 1 through 10. To stop scanning, just press **[MANUAL]** and you can select specific channels you want to listen to.

## Delay Function

When your PRO-2002 is scanning, it will stop whenever it finds a signal on a channel. As soon as the signal ends, the scanning function will resume. Most communications heard will be two-way. To make sure you don't miss any replies, press **[DELAY]**. This will cause your PRO-2002 to stay on a channel for three seconds after the end of a transmission, giving you time to hear any reply. To release the Delay function, just press **[DELAY]** again. The Delay indicator will show on the Display when the Delay function is used.

## Lockout Function

You may want your PRO-2002 to "skip over" certain frequencies while it's scanning (such as continuously transmitted weather broadcasts). To "lock out" such channels, follow these steps:

1. Press **[MANUAL]** to stop scanning. Continue to press **[MANUAL]** to advance to channel you want to lock out.
2. When you reach the channel, press **[LOCK OUT]**. The Display will show **L** to indicate that this channel will be skipped over during scanning.
3. To release the lockout, press **[MANUAL]** to stop scanning. Advance to channel that is locked out and press **[LOCK OUT]** once again. **L** will disappear from the Display.

If you use the lockout function on all channels, scanning will be impossible—you'll only be able to change channels using **[MANUAL]**.

## SPEED Selection

Your PRO-2002 will normally scan channels at a rate of three channels per second. If you press **[SPEED]**, channels will be scanned at a rate of six per second. Press **[SPEED]** again to return to a rate of three channels per second.

## Priority Function

You might want to scan other channels yet not miss a call on a channel of particular interest to you (police, fire, ambulance, etc.). The Priority function will let you scan other channels—but if a call is received on the Priority channel, your PRO-2002 will automatically switch to the Priority channel! Here's how to use the Priority function:

1. Press **MANUAL** Key.
2. Key in the desired Priority channel. Suppose you want 15 to be the Priority channel. Press **1** **5** and **PRIORITY**. The Display will momentarily show channel 15 and then return to the channel your PRO-2002 was on before you pressed **MANUAL**. This indicates that channel 15 has been correctly entered as the Priority channel. The Display will also have the Priority channel indicator showing.
3. To stop the Priority function, press **PRIORITY** again. Now your PRO-2002 won't switch to the Priority channel whenever a signal is received on it. To re-activate Priority, just press **PRIORITY** Key.
4. To change Priority channel, press **PRIORITY** to stop the Priority function. Enter new Priority channel as described in step 2.

Note: You can't manually change channels while the Priority function is activated. You'll have to press **PRIORITY** before pressing **MANUAL**.

## SEARCHING WITH YOUR PRO-2002

One great feature of your PRO-2002 is its ability to "search" for frequencies being used on each band. This means you can hear all the action on the airwaves in your area! You can store one Search range in each Bank, giving you a total of five Search ranges you can program. To use this great feature, just follow these steps:

1. Press **PROGRAM** Key.
2. Select **one** of the five Bank keys.
3. Press **LIMIT** Key. Enter the **lower** limit of the frequency range to be searched (such as 45.00 MHz). Press **ENTER**.
4. Press **LIMIT** Key again. Enter the **upper** limit of the frequency range to be searched (such as 46.00 MHz). Press **ENTER**.
5. Press either **▲** or **▼** to start Search. **▼** will start Search from highest frequency and go down while **▲** will start from the lowest frequency and go up.
6. You can control the speed of the Search by using the **SPEED** Key the same way you use it during scanning.
7. Search will stop when a frequency is found with a signal. To re-start Search, press **▲** or **▼**.

## Storing Frequencies

If you want to enter some of the frequencies found during Search, do this:

1. Press **MONITOR** when you PRO-2002 finds a frequency you want to store.
2. Use **MANUAL** Key to select a channel to enter the frequency your PRO-2002 found. The Display will show the frequency currently stored on the channel, but don't worry—the old frequency will be erased when you start to enter the new one.
3. Press **PROGRAM**.
4. Press **MONITOR** again. The new frequency found during the Search will be displayed.
5. Press **ENTER** to put the new frequency into the channel in the channel in place of the old frequency.
6. Press either **▲** or **▼** to resume the Search. To return to Manual or Program operation, press **MANUAL** or **PROGRAM**. To resume the Search from one of the limit frequencies, press **LIMIT** and then **▲** or **▼**.



## ERROR INDICATIONS

Sometimes when you try to enter a frequency for a channel or as a Search range limit, you may find an *Error* on the Display. This means the frequency is in error and you won't be able to enter it into your PRO-2002.

Such frequency errors usually mean you've entered a frequency outside the ranges your PRO-2002 operates on (such as 225.00 MHz) or you've put the decimal point in the wrong place (14.682 MHz instead of 146.82 MHz). Check carefully to find your mistake and then press **CLEAR**. You can now enter the correct frequency.

### *In case you're wondering . . .*

. . . the tuning range of your PRO-2002 is permanently stored in the microprocessor chip. There's no way it can be extended or altered—even by a skilled electronics technician. So if you try to enter a frequency not in the PRO-2002's tuning ranges, you'll get an error message every time! To listen to CB, shortwave or broadcasting bands, you'll need another receiver designed for that purpose (like our famous DX-302 shortwave receiver).

## SETTING THE CLOCK

Your PRO-2002 also has a built-in Clock which can be read from the Display. To set the Clock, do the following:

1. Turn on your PRO-2002 by rotating VOLUME clockwise.
2. Press **MANUAL** and then **CLOCK**.

3. Enter the current time. Suppose it is 35 seconds after 10:55 AM. Press **•/AM** **1** **0** **5** **5** **3** **5**. Display will now look like this:



4. Now press **ENTER**.
5. To once again see the frequency on the Display, press **CLOCK**.

You can check the time while monitoring simply by pressing **CLOCK**. The time will replace the frequency, but the channel and special symbols will still be seen, as in this example:

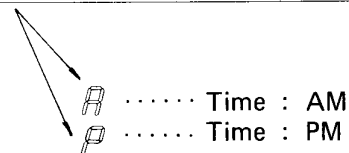
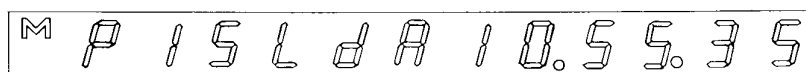

With your PRO-2002 OFF, the time will still be shown on the Display. If you don't want the time shown, press **CLOCK** to turn it off.

So long as the 9 volts Battery for memory backup is connected, the time will be kept for 5 – 10 seconds even when a power-failure takes place. If the power failed more than 5 – 10 seconds, the display flashes "E 00.00.00." indicating you have to reset clock.

## BIRDIES

Some frequencies may be difficult or impossible to receive. If you program-in one of these, the Scanner may lock up and you hear only noise. These "birdies" are the products of internally generated signals mixing with external signals like TV and FM broadcasts. Telescopic antennas are much more likely to pick up these undesirable signals—that is another good reason for getting an outdoor, base-station type antenna for home installations.

If the interference is not severe, you may be able to use **SQUELCH** to cut out such annoying birdies.

A few of the most common birdies to watch out for are listed below.

30.730 MHz	42.735 MHz
30.735	∩
30.745	42.860
32.000	44.790
32.005	∩
38.395	44.810
38.400	115.200
38.405	121.600
40.975	128.000
∩	
40.990	

Even with the **SQUELCH** control set to maximum, scanning or searching may stop on or around some of the frequencies listed above. If the spurious signal is strong enough (above 10  $\mu$ V in technical terms) you can listen to it, but the Receiver will not auto scan/search.

## MOBILE INSTALLATION

Safety and operating convenience are the primary factors to consider when you install any equipment in a vehicle. Be sure you can easily reach the Receiver's controls. Also, be sure the connecting cables do not interfere with the operation of the vehicle (brake, accelerator, etc.).

You can mount the Receiver to the underside of the dash or instrument panel in the vehicle. Use the universal mounting bracket provided. Take care when drilling holes that you do not drill into existing wires or trim.

The PRO-2002 is designed to operate from a negative ground 12-volt DC source. Be sure you connect power leads with the correct polarity. Use the DC Power cable provided.

The cable has two (brown and red) + leads and one black — lead. Connect the brown lead to accessory terminal, red lead to +12 volt always alive, and black lead to the negative ground. Be sure to observe correct voltage polarity: brown and red to "+" and black to "—."

**IMPORTANT:** If your car has been burning out headlamps and other bulbs at a rapid rate, first have the voltage regulator checked for proper output: excessive voltage (more than 16 volts) can damage your Receiver.

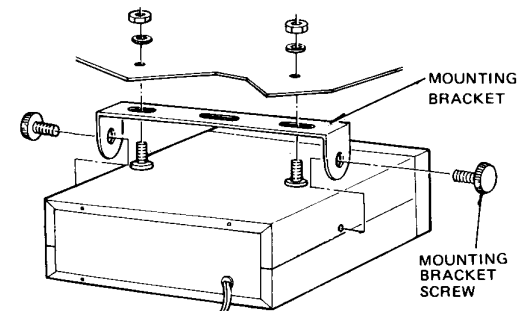

**NOTE:** The clock in your PRO-2002 will keep working even if the ignition is off. It will draw approximately 120mA of current. If you're not going to use your vehicle for a few days (such as a weekend), set the DC CLOCK/OUT switch on the rear of your receiver to OUT. This will turn off your PRO-2002's clock and protect your vehicle's battery. When you use your vehicle again, set DC CLOCK/OUT switch to DC CLOCK and then reset clock to correct time.

## Mobile Antenna

There are many possible mounting locations on a car. Three of the most popular locations for monitoring antennas are shown below.

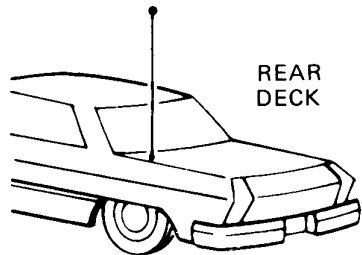
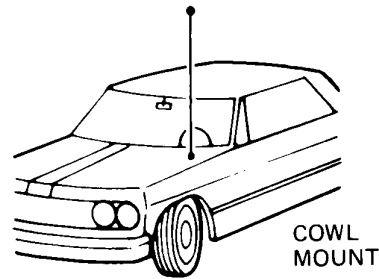
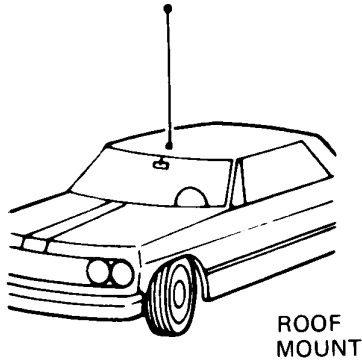

A convenient and efficient antenna for mobile use is Radio Shack's VHF-Hi/Lo UHF-Hi/Lo No-Hole Trunk Mount Mobile, 20-017.

Keep the following points in mind when installing your mobile antenna.

1. Mount it rigidly, so it will remain vertical while in motion.
2. Mount as far as possible from the engine compartment.



20-017

## MOBILE NOISE SUPPRESSION

Your PRO-2002 is a very sensitive receiver, and will pick up even extremely weak signals. This means that in addition to the tiny radio signals, radio-frequency noise may also be picked up and amplified.

In a mobile installation, it is important that you take steps to reduce the amount of noise that finds its way into the Receiver. If you take some or all of the steps recommended below, your reception should be quite satisfactory for mobile applications.

### Electrical System:

Generally speaking, noise can be generated by any device or connection that carries electrical current. Any device that generates a spark should also be suspected. Bypass any suspected wire to ground with a high quality 1  $\mu$ F coaxial capacitor.

A very common source of noise is the generator or alternator. This type of noise will sound like a musical whine, and will also vary with speed of the engine. Generator and alternator noise can usually be reduced by connecting a coaxial-type capacitor from the armature terminal to the metal case.

### Ignition System:

The ignition system is the most common source of noise. This noise can be identified by the fact that its speed varies with the engine speed. Ignition noise will sound like a series of "popping" sounds, while the engine is idling, and will speed up to a buzzing sound as engine speed is increased.

There are a number of things that can be done for this type of noise.

1. Use radio suppression-type ignition wire and resistor spark plugs.
2. Check high-voltage wiring for leakage, cracks, etc. Replace any wiring.
3. In extreme cases, obtain an ignition noise suppression kit—it should shield all ignition wiring. This will provide maximum suppression.

## Before Using Your PRO-2002 Mobile . . .

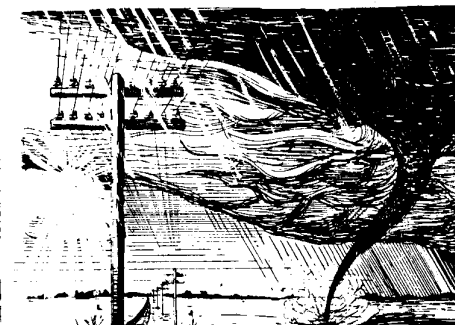
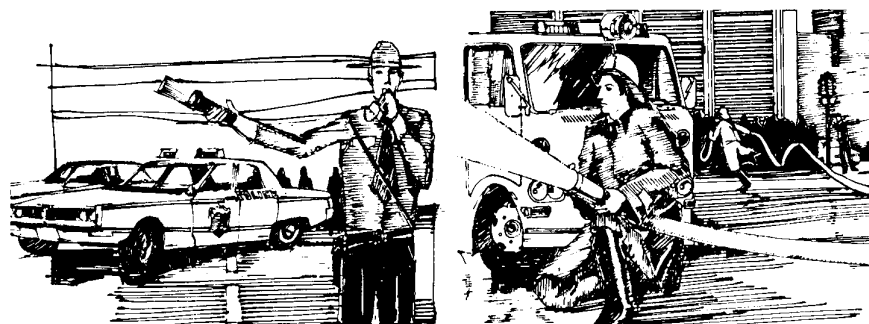

Using receivers capable of covering police, fire, emergency and ambulance frequencies in your car may be restricted by law in some areas. Before installing your PRO-2002 in your car, check to be sure of the regulations in your locality.

## GUIDE TO THE ACTION BANDS

Lots of things are going on that most of us just are never aware of. But, with the right frequencies programmed into your PRO-2002, you can monitor such exciting signals. You'll have to do a little investigating in your community to find out what services are active and on what frequencies. You will find one of our books to be very interesting and helpful in this area:

*REALISTIC GUIDE TO POLICE, FIRE AND AIRCRAFT RADIO.*

What to listen for and where? That is a little difficult for a specific answer. Each area of the country can and will use different channels. All we can do is give you some general pointers and then let you take it from there.

Find out if there is a local club which monitors these frequencies. Often a local electronics repair shop that does work on the equipment can give you the channel frequencies used by local radio services. A volunteer police or fire employee can also be a good source of this information.

An interesting service is the Mobile Telephone. FCC has assigned this service channels in the range of 152.51 to 152.81 MHz at every

0.030 MHz (channels are 30 kHz apart). Also, 454.375 to 454.95 MHz with channels 25 kHz apart from 454.375 to 454.625 and then every 50 kHz up to 454.95.

As a general rule on VHF, most activity will be concentrated between 153.785 and 155.98 and then again from 158.73 to 159.46 MHz. Here you'll find local government, police, fire and most such emergency services. If you are near a railroad yard or major railroad tracks, look around 160.0 to 161.9 for them.

In some of the larger cities, there has been a move to the UHF bands for these emergency services. Here, most of the activity is in a spread of 453.025 – 453.95 and again at 456.025 – 459.95 MHz.

In the UHF band, the overall spread of 456.025 – 459.95 and again at 465.025 – 469.975 MHz is used by mobile units and control stations associated with base and repeater units which operate 5 MHz lower (that is, 451.025 – 454.95 and 460.025 – 464.975 MHz). This means that if you find an active channel inside one of these spreads, you can look 5 MHz lower (or higher as the case may be) to find the major base station/repeater for that radio service.

A handy book to have is the *POLICE CALL RADIO DIRECTORY* for your region. Stop by your local Radio Shack store and ask about it. It has complete listings, by frequency, of the various radio services in the bands covered by your PRO-2002. These Directories are updated every year, so get a current one.

# TYPICAL BAND USAGE

The following is an abbreviated listing of what's going on in the frequency ranges your PRO-2002 can receive—it'll help you decide which ranges you'd like to choose. Here's a list of abbreviations used:

Affiliate Radio System	MARS	Mobile Telephone	Mob. Tel.
Armateur	Ham	Motion Picture	Mot. P.
Automobile Emergency	Auto Emer.	Motor Carrier	Buses, Trucks
Broadcast Remote	BC. R.	National Parks	Nat. Pk.
Bureau of Reclamation	Bur. Recl.	Petroleum	Pet.
Civil Air Patrol	CAP	Police	P.D.
Department of Agriculture		Power Utilities	Power
and Forestry	Agr. and For.	Radio Paging	Page
Fire Department	F.D.	Railroad	R.R.
Forest Products	For. Prod.	Red Cross	
Forestry Conservation	Fors. Cons.	Relay Press	Press
Government	Govt.	State Police	St. P.D.
Highway Maintenance	Hwy.	Special Emergency	Sp. Ind.
Indian Affairs		Taxicab Radio	Taxi
Land Transportation	Land Tr.	Telephone Maintenance	Tel. Maint.
Local government	L. Govt.	U.S. Coastal	
Manufactures	Mfg.	and Goedetic Survery	U.S.C.G.S.
Marine		U.S. Navy	USN
Military	MIL	U.S. Weather Bureau	U.S.W.B.

30 ~ 50 MHz Band (0.020 MHz or 20 kHz spacing)		39.02 ~ 39.98	P.D., L. Govt.
30.01 ~ 30.56	Govt.	40.00 ~ 42.00	Govt.
30.56 ~ 30.62	Sp. Ind.	42.02 ~ 42.94	St. P.D.
30.66 ~ 31.24	Ind. (Pet., For. Cons., Bus., For. Prod.)	42.96 ~ 43.18	Sp. Ind. & Bus.
31.26 ~ 31.98	Sp. Ind., For. Cons.	43.22 ~ 43.68	Mob. Tel. Page
32.00 ~ 33.00	Govt.	43.70 ~ 44.60	Trucks, Bus.
33.02 ~ 33.16	Hwy., Sp. Emer., Bus.	44.62 ~ 45.06	St. P.D., For. Cons.
33.18 ~ 33.38	Pet.	45.08 ~ 45.66	P.D.
33.42 ~ 33.98	F.D.	45.68 ~ 46.04	P.D. Hwy., Sp. Emer.
34.00 ~ 35.00	Govt.	46.06 ~ 46.50	F.D.
35.02 ~ 35.18	Bus.	46.52 ~ 46.58	L. Govt.
35.22 ~ 35.66	Mob. Tel. & Page	46.60 ~ 47.00	Govt.
35.70 ~ 35.72	Bus.	47.02 ~ 47.40	St. Hwy.
35.74 ~ 35.98	Sp. Ind. & Bus.	47.42	Red Cross
36.00 ~ 37.00	Govt.	47.44 ~ 47.68	Sp. Ind., Sp. Emer.
37.02 ~ 37.44	P.D. & L. Govt.	47.70 ~ 48.54	Power
37.46 ~ 37.86	Power	48.56 ~ 49.58	For. Prod., Pet.
37.90 ~ 37.98	Hwy. & Sp. Emer.	49.60 ~ 50.00	Govt.
38.00 ~ 39.00	Govt.	108 ~ 136 MHz Band	

108 ~ 118	Air Navigation
118 ~ 136	Aircraft

144 ~ 148 MHz 2 Meter Amateur (Ham) Band	169.450 ~ 169.725	Ind., Data
148 ~ 174 MHz Band Mixed Spacing (15, 20, 25 kHz)	170.150	F.D., BC. R.
	170.200 ~ 170.220	U.S.C.G.S.
	170.225 ~ 170.325	Ind., Land Tr.
	170.425 ~ 170.575	For. Cons.
	170.975 ~ 171.250	Govt. Ind., Land Tr.
	171.388 ~ 172.725	Bur. Recl., For. Cons., Ind., Dept. Ag. & For., Govt.
148.010		MARS
148.15		CAP
148.155 ~ 148.250		MIL
148.290 ~ 150.750		USN
150.815 ~ 150.995		Bus.
151.010 ~ 151.130		Hwy.
151.145 ~ 151.475		For. Cons.
151.505 ~ 151.595		Sp. Ind.
151.625 ~ 151.955		Bus.
151.985 ~ 152.240		Mob. Tel. (RCC)
152.270 ~ 152.450		Taxi
152.480 ~ 152.840		Mob. Tel. Page
152.870 ~ 153.020		Sp. Ind., Mot. P.
153.050 ~ 153.440		Pet., For. Prod.
153.470 ~ 153.710		Power
153.740 ~ 154.115		L. Govt.
154.130 ~ 154.445		F.D.
154.450 ~ 154.600		Sp. Ind., Pet., Bus.
154.655 ~ 155.145		P.D., L. Govt., St. P.D.
155.160 ~ 155.400		Sp. Emer., P.D.
155.415 ~ 156.030		P.D., L. Govt.
156.045 ~ 156.240		Hwy., P.D.
156.275 ~ 157.425		Marine
157.456 ~ 157.500		Auto Emer.
157.530 ~ 157.710		Taxi
157.740 ~ 158.100		Mob. Tel., Page
158.130 ~ 158.460		Power, For. Prod., Pet.
158.490 ~ 158.700		Mob. Tel. (RCC)
158.730 ~ 158.970		P.D., L. Govt.
158.985 ~ 159.210		P.D. Hwy.
159.225 ~ 159.465		For. Cons.
159.510 ~ 160.200		Trucks
160.215 ~ 161.565		R.R.
161.600 ~ 162.000		Marine
162.026 ~ 162.175		Bur. Recl.
162.400		U.S.W.B.
162.550 ~		U.S.W.B.
163.125 ~		Indian Affairs
163.175 ~		Bur. Recl.
163.275		U.S.W.B.
163.388 ~ 163.538		MIL
163.825 ~ 163.975		Govt.
164.025 ~ 164.075		U.S.C.G.S.
164.175 ~ 165.188		Bur. Recl., Nat. Pk., Govt., Agr. & For.
169.300		F.A.A.

430 ~ 450 MHz Amateur (Ham) Band	
450 ~ 512 MHz Band (25 kHz Spacing)	
450.050 ~ 450.950	BC. R.
451.000 ~ 451.150	Util.
451.175 ~ 451.750	For. Prod., Pet., Pwr., Tel. Maint
451.775 ~ 451.975	Spec. Ind.
452.000 ~ 452.500	Taxi, Mot. Carrier, R.R.
452.525 ~ 452.600	Auto Club
452.625 ~ 452.975	Motor Carr., R.R.
453.000 ~ 453.975	L. Govt., P.D., F.D.
454.000 ~ 454.975	Mob. Tel.
455.000 ~ 455.975	Remote Br.
456.000 ~ 458.975	P.D., F.D., Ind., Lan. Tr.
459.000 ~ 459.975	Domestic Public
460.000 ~ 460.625	P.D., F.D.
460.650 ~ 462.175	Bus.
462.200 ~ 462.450	Taxi
462.750 ~ 462.975	Bus.
463.000 ~ 463.175	Medical
463.200 ~ 464.975	Bus.
465.000 ~ 467.500	P.D., F.D., Ind., Land Tr.
467.750 ~ 467.925	Bus.
467.7375 ~ 469.975	Pub. Safety, Ind., Land Tr.

In some large metropolitan areas, 1 or 2 channels of the “TV Band” (470 MHz to 512 MHz) are used for special communications. Each station (channels 14 through 20) uses 6 MHz:

- 470 ~ 476 T.V. Channel 14
- 476 ~ 482 T.V. Channel 15
- 482 ~ 488 T.V. Channel 16
- 488 ~ 494 T.V. Channel 17
- 494 ~ 500 T.V. Channel 18
- 500 ~ 506 T.V. Channel 19
- 506 ~ 512 T.V. Channel 20

Where these frequencies are assigned for special communications, in lieu of a T.V. station, the 6 MHz segment is allocated as shown here for channel 14 (470 ~ 476 MHz).

470.0125 ~ 470.2875 . . . . . Domestic Public, (Base, Mob.)	473.0125 ~ 473.2875 . . . . . Domestic Public
470.3125 ~ 471.1375 . . . . . Public Safety	473.3125 ~ 474.1375 . . . . . Public Safety
471.1625 ~ 471.2875 . . . . . Reserve Pool A	474.1625 ~ 474.2875 . . . . . Reserve Pool A
471.3125 ~ 471.4125 . . . . . Pwr., Tel. Maint.	474.3125 ~ 474.4125 . . . . . Pwr., Tel. Maint.
471.4375 ~ 471.6375 . . . . . Spec. Ind.	474.4375 ~ 474.6375 . . . . . Spec. Ind. (Mobile)
471.6625 ~ 471.7875 . . . . . Reserve Pool B	474.6625 ~ 474.7875 . . . . . Reserve Pool B
471.8125 ~ 472.3375 . . . . . Bus.	474.8125 ~ 475.3375 . . . . . Bus.
472.3625 ~ 472.4375 . . . . . Taxi	475.3625 ~ 475.4375 . . . . . Taxi
472.4675 ~ 472.7875 . . . R.R., Motor Carrier, Auto Emer.	475.4625 ~ 475.7875 . . . R.R., Motor Carrier, Auto Emer.
472.8125 ~ 472.9875 . . . Pet., For. Prod., Mfg.	475.8125 ~ 475.9876 . . . Pet., For. Prod., Mfg.

The same allocation pattern is repeated for each of the TV channels 14 thru 20. For example, if channel 17 is assigned for communications in your area, “Taxi” would be 490.3625 to 480.4375 and 493.3625 to 493.4375 (corresponding to 472.3625 to 472.4375 and 475.3625 to 475.4375 above). Note that in the example, we added three TV channels (18 MHz) to the channel 14 frequencies.

## SOME RANDOM NOTES

You’ll soon notice some differences between reception on the aircraft band (108–136 MHz) and the other ranges covered by your PRO-2002. Aircraft band stations use AM, while stations on the other ranges covered by your PRO-2002 use FM. Don’t be too surprised if reception is a bit “noisier” on the aircraft band than others. Your PRO-2002 will automatically switch over to AM or FM depending on the frequency you wish to listen on.

Reception on the frequencies covered by your PRO-2002 is mainly “line of sight.” That means you usually won’t be able to hear stations located beyond the horizon at your listening location. You’ll be able to hear aircraft at greater distances than ground stations. And during the summer months you may be able to hear stations in the 30–50 MHz range located several hundred or even thousands of miles away. This is due to summer atmospheric conditions; this type of reception is unpredictable (but often very interesting!).

One very useful service is the National Weather Service’s continuous weather broadcasts. These broadcasts contain weather forecasts and data for the area around the station plus bulletins on any threatening weather conditions. These stations use three frequencies—162.40, 162.475 or 162.55 MHz. In most areas of the country you will be able to receive one of these frequencies



# BLOCK DIAGRAM

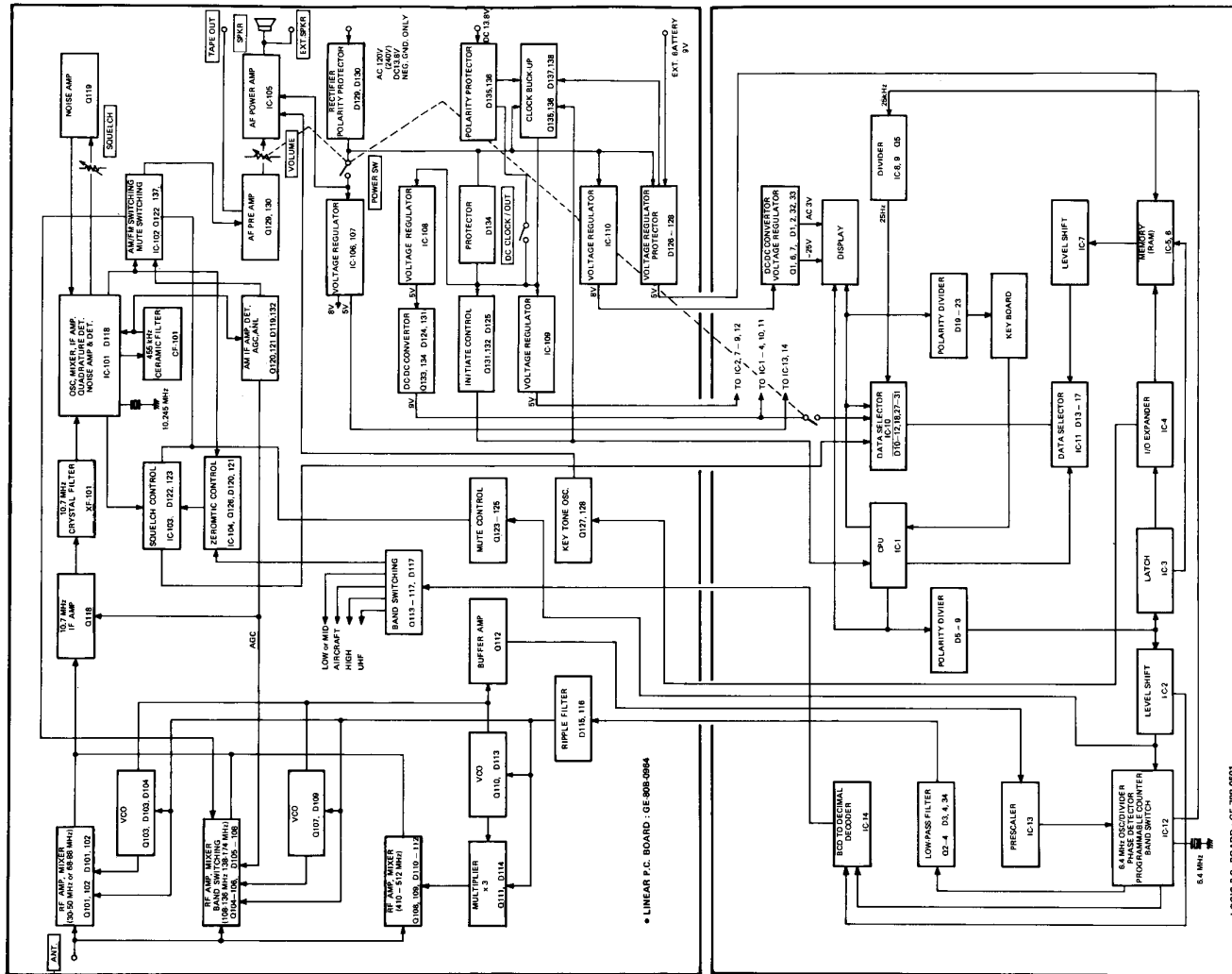

**RADIO SHACK**  **A DIVISION OF TANDY CORPORATION**

**U.S.A.: FORT WORTH, TEXAS 76102**  
**CANADA: BARRIE, ONTARIO L4M 4W5**

**TANDY CORPORATION**

AUSTRALIA

BELGIUM

U. K.

280-316 VICTORIA ROAD  
 RYDALMERE. N.S.W. 2116

PARC INDUSTRIEL DE NANINNE  
 5140 NANINNE

BILSTON ROAD  
 WEDNESBURY, WEST MIDLANDS WS10 7JN