

CRYSTAL RECEIVERS FOR BROADCAST RECEPTION

BY

PERCY W. HARRIS

AUTHOR OF "THE A B C OF WIRELESS"

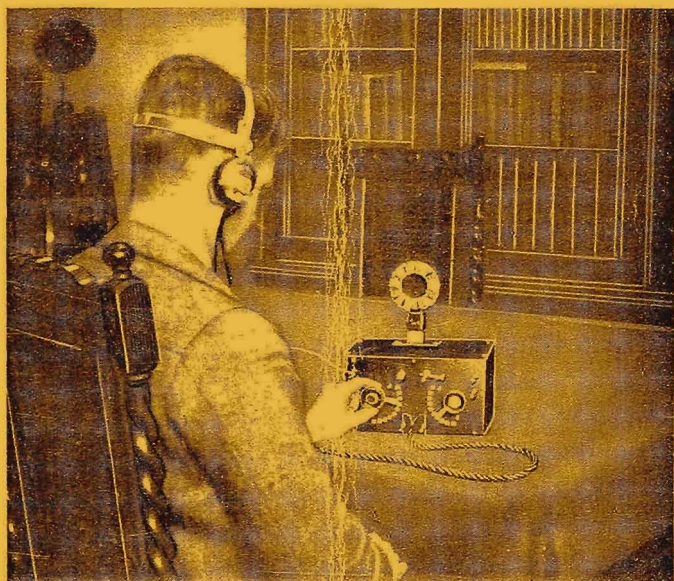

RECEIVING A WIRELESS CONCERT WITH A HOME-MADE
CRYSTAL RECEIVER.

LONDON

THE WIRELESS PRESS, LTD.

12 & 13, HENRIETTA STREET, W.C. 2

CRYSTAL RECEIVERS FOR BROADCAST RECEPTION

BY

PERCY W. HARRIS

AUTHOR OF "THE A B C OF WIRELESS"

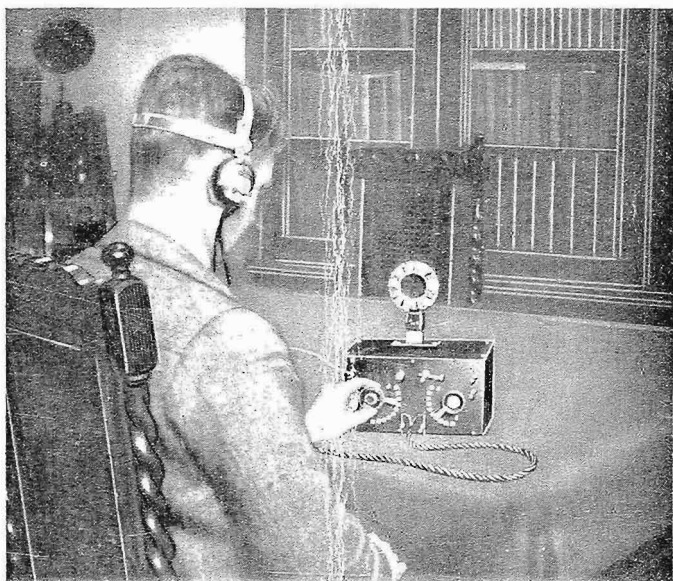

RECEIVING A WIRELESS CONCERT WITH A HOME-MADE
CRYSTAL RECEIVER.

LONDON

THE WIRELESS PRESS, LTD.

12 & 13, HENRIETTA STREET, W.C. 2

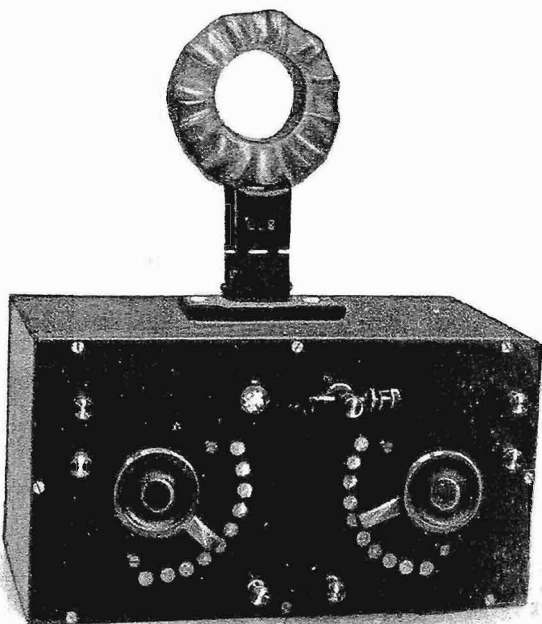

A HOME-MADE CRYSTAL RECEIVER WITH ADJUSTMENTS FOR BROADCAST WAVE-LENGTHS AND EIFFEL TOWER TIME-SIGNALS. INSTRUCTIONS FOR BUILDING THIS SET ARE GIVEN IN CHAPTER X.

CRYSTAL RECEIVERS FOR BROADCAST RECEPTION

BY

PERCY W. HARRIS

AUTHOR OF "THE A B C OF WIRELESS," ETC.

LONDON

THE WIRELESS PRESS, LTD.

12 & 13, HENRIETTA STREET, W.C. 2

NEW YORK: WIRELESS PRESS INC., 326 BROADWAY

1922

THE WIRELESS PRESS, LTD.
FOREIGN AND COLONIAL AGENCIES:

SYDNEY, N.S.W.: 97, Clarence Street.

MELBOURNE: 422/4, Little Collins Street.

MADRID: La Prensa Radiotelegrafica, 43, Calle de Alcala.

GENOA: Agenzia Radiotelegrafica Italiana, Via Varese 3.

AMSTERDAM: Nederlandsch Persbureau Radio, 562,
Keizersgracht.

INTRODUCTION

THE advent of broadcast radio-telephony has aroused considerable interest in the simple forms of wireless receiver, with the result that the crystal detector, which was fast being ousted by the thermionic valve, has once again become popular. Numerous crystal receivers are now on the market, and the beginner in wireless may well feel some confusion as to their merits. The purpose of this book is to explain in popular language the principles upon which all these receivers are designed, the reasons for the differences between them, and how all of them can be adjusted for the greatest efficiency. To meet the requirements of those who desire to construct their own apparatus, a detailed description is given of the construction of a high-grade crystal receiver suitable for the reception of broadcast concerts and wireless time-signals from the Eiffel Tower station in Paris.

The author desires to express his obligation to the following firms who have kindly supplied illustrations of their particular products :—

Messrs. G. C. Aimer & Co., G. Z. Auckland & Son, Henry J. Brewster & Co., British Radio Sales Co., Ltd., S. G. Brown, Ltd., Burndept, Ltd., Dubilier Condenser Co. (1921), Ltd., Fellows Magneto Co., Ltd., A. W. Gamage & Co., Ltd., General Electric Co., Ltd., Marconi's Wireless Telegraph Co., Ltd., R. M. Radio, Ltd., Sterling Telephone and Electric Co., Ltd., A. W. Sullivan, Wireless Supplies Co., Ltd.

PERCY W. HARRIS.

LONDON,

September 30th, 1922.

TABLE OF CONTENTS

CHAP.	PAGE
INTRODUCTION	iii
I. GENERAL PRINCIPLES OF WIRELESS RECEPTION.	7
II. CRYSTAL RECTIFIERS AND THEIR PROPERTIES .	11
III. TUNERS FOR CRYSTAL RECEIVERS	18
IV. PRACTICAL CRYSTAL DETECTORS	40
V. TELEPHONE HEADPIECES	45
VI. AERIALS AND EARTH CONNECTIONS	48
VII. WHAT YOU MAY EXPECT TO HEAR WITH A CRYSTAL RECEIVER	51
VIII. HOW TO ADJUST A CRYSTAL DETECTOR	53
IX. MAKING SIGNALS LOUDER	56
X. HOW TO BUILD A CRYSTAL RECEIVER	58
<hr/>	
APPENDIX A	70
APPENDIX B	72
APPENDIX C	73

CRYSTAL RECEIVERS FOR BROADCAST RECEPTION

CHAPTER I

GENERAL PRINCIPLES OF WIRELESS RECEPTION

A WIRELESS receiver, whether for telegraphy or telephony, consists of some means of converting ether waves into audible sounds which can be interpreted by the user. The chief difference between wireless telegraphy and wireless telephony is that in the former case the signalling waves are cut up into long and short trains of waves corresponding with the dots and dashes of the Morse code, while in the latter a continuous stream of waves has its amplitude varied by the transmitting apparatus in a manner corresponding to the sound waves which impinge upon the transmitting diaphragm.

To the beginner it seems impossible that a number of wireless telegraphic and telephonic transmissions can occur simultaneously without the listener hearing a horrible jumble of sounds, consisting of Morse, music and speech, from a multitude of sources. Actually, however, it is possible to eliminate most of those not required by utilising the principles of electrical resonance. To understand resonance we must consider for a few moments certain fundamental properties of wireless circuits.

The ether waves used in wireless telegraphy generate in any conductor upon which they fall feeble electrical currents of a frequency depending upon the wave-length of the waves themselves. The speed of transmission of all wireless waves is practically uniform, being that of light, which travels at 186,200 miles per second. Each complete wave will generate in a receiving aerial two tiny currents, one half of the wave causing a downward rush of current of the aerial, and the other half a similar upward rush.

Now each electrical conductor has what is known as a

“natural frequency.” This is dependent upon what are known as the “capacity” and “inductance” of the wire or circuit. These properties of wireless circuits are fully dealt with in most books on wireless telegraphy, and it will suffice, for the purpose of this chapter, to state that if we increase the length of an aerial wire, we usually increase its inductance and its capacity at the same time.

If by some means we impart an electrical impulse to an aerial, a current will rush upwards and downwards, or “oscillate,” in this aerial at a certain frequency depending upon its capacity and inductance. If we increase either the capacity or the inductance in the circuit, we shall *decrease* its electrical frequency, and the whole art of wireless tuning consists in adjusting the natural frequency of the aerial and its associated circuits to the frequency which is suitable for the wave-length we require to receive.

Let us study for a moment what happens in a receiving aerial when a stream of waves of, say, 300 metres wave-length traverses the space in which the aerial is situated. The first half of each wave will cause either a downward or an upward rush of current, and the second half a similar flow in the opposite direction. The next wave of the series will cause a corresponding downward and upward rush, and so on, as long as the stream of waves continues. We have already seen if we suddenly start a current in an aerial wire it will rush up and down at a frequency depending on the properties of the aerial, and it will now be understood that if the impulses received from the passing waves correspond in frequency with those of the oscillations or up-and-down rushes of current in the aerial, a cumulative effect will be produced analogous to the regularly timed impulses given to a child's swing. A 300-metre wave will set up in an aerial currents of a frequency of exactly 1,000,000 per second; 600-metre waves create currents of 500,000 frequency, and so on throughout the whole range of waves dealt with by wireless receivers. A building-up effect will only be obtained if the natural frequency of the aerial corresponds with the frequency of the currents set up by passing waves. If, however, we happen to be receiving from a distant station, the waves from which are very attenuated by the time they reach us, and simultaneously, and close at hand, a powerful station is working, it may be that the waves from this latter will be sufficiently powerful to “force” our aerial into oscillation, whereupon a certain amount

of confusion will arise, known as "jamming" or "interference." Generally speaking, however, it may be said that the principle of resonance enables us to make our apparatus sensitive to the wave-lengths that we wish to receive, and relatively insensitive to all others.

How, now, can we turn these electrical currents (whether they convey Morse or speech and music) into sounds audible to the listener? A familiar device for converting electrical currents into sound is the telephone receiver. Every tiny rush of current which passes through such a receiver makes a click, and if these clicks are regular and succeed one another sufficiently rapidly, they will merge into a musical buzz. The more rapid this buzz, the higher will be the note we shall hear, until the rapidity is such and the note so high that it ceases to be audible to the human ear.

Now the frequency of the tiny electrical currents generated in the aerial is far higher than the highest point of audibility which the human ear can reach. Furthermore, for electrical reasons of a technical nature, these very high frequency currents will not pass through the windings of a telephone receiver. In order that the received currents may traverse the telephone it is necessary that they should be "rectified" or turned into a current which is proceeding in one direction only. A steady stream of waves will produce in a received aerial suitably tuned, a regular high frequency current of uniform strength, the frequency, as we have said, being far above audibility. If, now, by some means later to be explained, we can rectify these high frequency currents, we can turn them into a uniform electric current in one direction which will pass through the telephones. A telephone receiver, however, is only sensitive to *changes* in strength of current, and a steady current passed through the telephone will merely make a click when it starts, and a further click when it stops. When we wish to transmit Morse signals by wireless telegraphy we adopt methods which will cause these rectified currents to increase and decrease in strength at an audible frequency (usually a musical buzz), and if our wireless receivers are tuned to wave-lengths on which Morse signals are being sent, we shall hear long and short buzzes corresponding with the dots and dashes of the code.

The waves which are sent out from a wireless *telephony* station, while consisting of a steady system of waves which create currents of a frequency above audibility, are modulated or vary in strength in sympathy with the sound waves at the

transmitter. Briefly stated, then, if we rectify the high frequency currents set up by waves from a wireless telephone station, we shall obtain through our telephones a uni-directional current which varies in strength in a manner corresponding to the variation of sound waves on the transmitter, and we shall hear a more or less faithful reproduction in our head pieces or loud speaker of the sounds or music, made or spoken, at the distant transmitting station.

It will thus be seen that a wireless receiver of whatever type we like to consider has three functions to perform. Firstly, it must be so arranged that the aerial to which it is connected can be brought into electrical resonance with the waves to be received. Secondly, high frequency currents created in the aerial and receiver must be rectified or turned into uni-directional currents which will affect the telephones. Thirdly, the apparatus must have some form of telephone receiver which will be operated by these rectified currents.

In broadcast reception we have available for use two distinct types of receiver. Each type is made up of three parts, tuner, detector or rectifier, and telephones. One type is known as the crystal receiver, and the other as the valve receiver. Each type has its advantages.

On the one hand the crystal receivers are simple to operate, inexpensive both to purchase and maintain, and require no expensive and messy accumulators to supply electrical current to them. On the other hand, valve receivers are very much more sensitive and, seeing that the thermionic valve is capable of acting not only as a rectifier but also as a magnifier, it is possible to use a number of valves, each of which multiplies the strength of signal produced by the others. Valve receivers are, however, expensive to purchase in the first place, costly in regard to replacements of worn-out or broken valves, and require both high and low tension batteries to supply electric current to them. Furthermore, if the highest efficiency is to be obtained from them, they need skilled manipulation.

Crystal receivers, if used within twenty or thirty miles of a broadcasting station, will give quite good results in one or two pairs of telephone headpieces, and on rare occasions music has been received from broadcasting stations at much greater distances. In this book only crystal receivers are dealt with. For particulars of valve receivers, their operation and working, the reader is referred to the many excellent text-books already available.

CHAPTER II

CRYSTAL RECTIFIERS AND THEIR PROPERTIES

ABOUT the year 1906 certain American experimenters made the remarkable discovery that crystals of some mineral substances possess the property of allowing high-frequency currents to pass through them in one direction, but not in the other. One of the earliest substances to be investigated was the synthetic product, Carborundum. Carborundum (or, to give it its chemical name, Silicon Carbide) is produced in large quantities, at works near Niagara Falls, by fusing in electrical furnaces a mixture of salt, sand, sawdust and coke. A number of complex chemical reactions take place in the furnace, and when the mass cools, a substance, to which the name Carborundum has been given, crystallises out in great masses. It is probable that many readers have seen blocks of carborundum used for advertising purposes in shop windows. It may have been noticed that the colour of the carborundum varies throughout the mass, the crystals in one portion being of a reddish violet colour, whereas in other portions they are black, steel blue, pale green or other tints. Carborundum is an extremely hard substance, and it is this property which makes it of value commercially. Not all specimens of carborundum possess the peculiar rectifying property to which we have referred, and out of a block weighing many pounds only a few ounces of carborundum crystals useful for wireless purposes will be found. Considerable skill is required to pick out the best specimens for this work.

If we take a suitable crystal of carborundum into the wireless laboratory and suitably connect it to an electrical circuit, we shall find that as we increase the electrical pressure applied to it in one direction, so the current through it will increase. If we reverse the electrical pressure, we shall find that in the opposite direction practically no current will pass. In studying the rectifying properties of carborundum, and indeed all other crystal substances, we draw what is known as a "characteristic curve." The characteristic curve of a crystal of carborundum is shown in Fig. 1.

The horizontal line in this figure shows volts applied to the crystal, the zero line being in the centre. To the left of this line the volts are negative, and on the right positive. The vertical line shows microamperes of current passing through

the crystal for the various voltages applied. It will be noticed that the curve has a distinct "hump." If we were to take the characteristic current of a metal or other good conductor we should find that the line joining the various readings would be perfectly straight, in accordance with Ohm's law. In the case of crystal rectifiers, however, the curve is not straight, and it is this irregularity in the shape which gives us a means of ascertaining the value of the particular specimen as a rectifier.

To get the best rectification, we want to "use" the curve at the point where it changes most rapidly. In the case of this

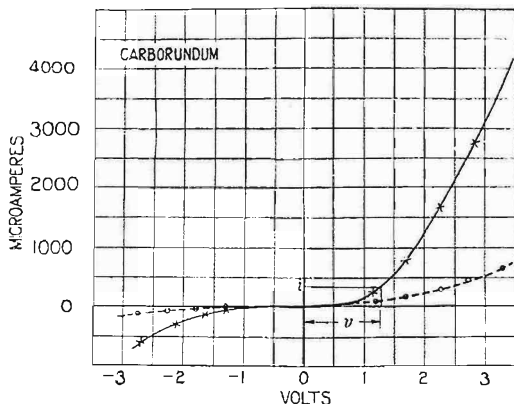

FIG. 1.—Characteristic Curve of a Crystal of Carborundum. This shows us at what voltage the crystal will best rectify, and what degree of rectification we can obtain.

specimen of carborundum the change will be seen to take place at the point marked 1.2 volts. Now let us assume that by means of a dry cell we impose a regular pressure of 1.2 volts upon the particular specimen of carborundum, and maintain this pressure during reception of wireless signals. We will imagine for the moment that the wireless receiver is connected to this crystal so that the high frequency currents can act upon it.

When there is a rise in pressure in one direction through the crystal, due to the additional effect of the incoming waves, the current will increase, corresponding to the increase in pressure as shown by the curve. The reversal of the oscillation will

subtract voltage and cause a fall in current, but the fall will be less than the previous rise. If, then we subtract the decrease from the increase, the net result will be an increase. The reader is advised to study this characteristic for a little time and think over what must occur with the variations in pressure. He will soon realise that the carborundum crystal acts as a kind of valve, allowing a passage of current in one direction, but not to any great extent in the other. He will also realise that the sharper the bend in the curve the better will be the rectifying effect. It will also become clear to him that in the case of carborundum we cannot obtain satisfactory rectification unless we impress upon the crystal, from some external

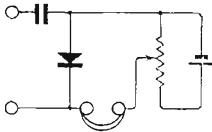

FIG. 2.—Connections of a Potentiometer. The black triangle and thick line represent the crystal, the zig-zag line a resistance, the long and short line a dry cell. The arrow-head represents a sliding connection and the two thick lines on the left indicate a fixed condenser.

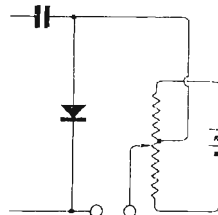

FIG. 3.—Connections of a Potentiometer by which the Direction of Electrical Pressure can be reversed on passing mid-point of the Resistance.

source, a steady electrical pressure of 1.2 volts or so. If we could find a crystal of carborundum the characteristic curve of which showed that the sudden change in shape of the curve took place at zero volts, then we could use it in a wireless circuit without impressing upon it any voltage other than that derived from the effect of the wireless waves. Unfortunately such crystals of carborundum are but rarely, if ever, found.

For the purpose of applying the additional voltage to bring the carborundum crystal into the necessary sensitive condition we use a device known as a "potentiometer." This consists of a resistance of several hundred ohms connected to one or two dry cells. If we apply a voltmeter to the two ends of this resistance when a current from one dry cell is flowing through

it, we shall obtain a reading of approximately 1.5 volts. If, still keeping one terminal of the voltmeter connected to one end, we apply the other terminal to the centre of the resistance, we shall obtain a reading of only .75 volt, or half the previous figure. Similarly testing a quarter of the resistance we shall find the voltage to be only a quarter of the whole.



FIG. 4.—A Rotary Potentiometer.

By permission of A. W. Gamage & Co., Ltd.

From this experiment we find, then, that we can gradually vary the voltage by moving a contact from one end of the resistance to the other, and this supplies a convenient means of adjusting the applied voltage of a carborundum detector, or other crystal which we may want to test with additional voltage. The method of connecting a potentiometer in circuit is shown in Fig. 2. Fig. 3 shows the wiring of a potentiometer which enables the voltage to be reversed after passing the central point of the resistance. This is more convenient than using a reverse switch or disconnecting the leads.

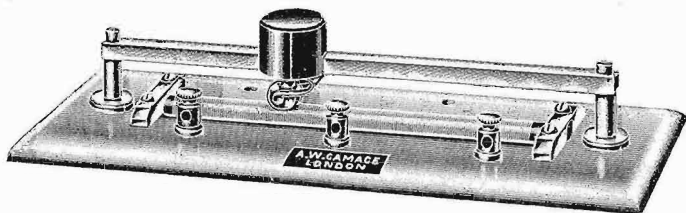

FIG. 5.—Sliding Potentiometer.

By permission of A. W. Gamage & Co., Ltd.

The resistance usually takes the form of a coil of wire on a former, over which runs a suitable sliding contact. This coil may be wound on a cylindrical square or other kind of former, and is sometimes made ring-shaped. Some potentiometers use resistances made of carbon rods, and the stud-switch

method may take the place of a slider. Practical forms of potentiometer are shown in Figs. 4 and 5.

It is natural that the discovery of the rectifying properties of carborundum should lead to the investigation of other substances to see whether they, too, gave characteristic curves of a similar useful shape. It was soon found that a large number of natural mineral crystals possessed more or less useful rectifying properties, although some were far superior to others. Galena (a natural oxide of lead) is one of the most sensitive of such crystals. Fused silicon, which is also good, molybdenite (an oxide of the rare metal molybdenum), iron pyrites, copper pyrites, and many other mineral ores have also been used commercially. A very popular, useful and sensitive rectifier is made by placing in contact two crystals. Combinations which work excellently are zincite (natural oxide of zinc) and copper pyrites, zincite and chalcopyrite (a complex copper ore containing both copper and iron) and zincite and bornite (a further copper ore). Combinations of zincite with these copper ores usually go under the name of "Perikon," the title given to them by Greenleaf W. Pickard, who invented this series of detectors. All of these crystals and crystal combinations, other than carborundum, have the distinct advantage that the "hump" in the characteristic curve occurs at the zero point, which means that we can use these detectors without any special applied voltage.

A number of excellent crystals pass under trade names, such as "Cerussite," "Hertzite," "Radiocite," "Permanite," etc. Without particular reference to those just mentioned, it may be said that many crystals sold under special trade names consist of specially-treated galena.

Each kind of crystal rectifier has its own peculiarities, and to obtain the best results from them these peculiarities must be recognised. Carborundum, for example, varies greatly in its rectifying properties and requires to be carefully chosen. Metallic contact with all crystals is usually made by fixing them in a metal cup with a form of solder known as "Wood's" metal, which has a very low melting point. Ordinary solder should never be used, as the heat required to melt it injures the crystal. The surface of the crystal is left exposed and contact made with it by various means depending upon the particular type of detector. Good results with carborundum are obtained by pressing the crystal against a polished steel plate, although a brass plate will also serve the

purpose. Another method which can be used satisfactorily with carborundum is to allow the tip of a fine wire to rest upon its surface. Galena (whether natural or treated), silicon, molybdenite, iron pyrites, and copper pyrites, all work best with light contact of a fine wire point. The wire is best made of a substance which does not readily oxidise, as even a thin

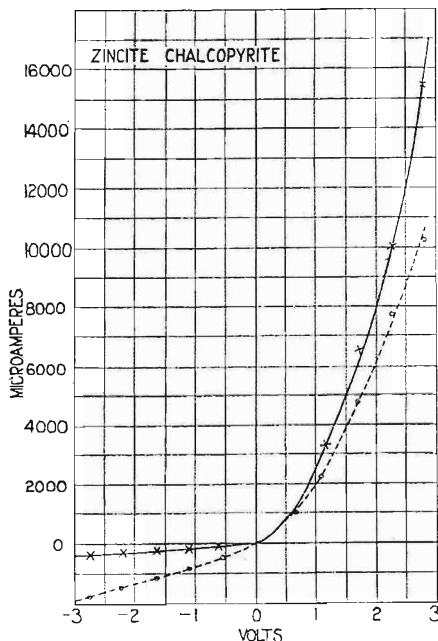

FIG. 6.—Two characteristic Curves of Different points of Contact between a Crystal of Zincite and a Crystal of Chalcopyrites. The dotted curve is that of the least sensitive contact.

film of oxide upon this point is detrimental. For this reason fine gold or platinum wires are sometimes used. In the case of combinations of two crystals, both are fitted into cups by means of fusible metal, and the two crystal surfaces brought together with a fairly firm pressure.

A given crystal is never uniformly sensitive over its whole surface, there being both good and bad points. Trial must therefore be made to find the best position. Galena, for

example, has many points on its surface which are entirely insensitive. The zincite combinations have the advantage that, whilst they are not uniformly sensitive over their whole surface, they usually possess some rectifying properties practically everywhere. Fig. 6 shows a typical characteristic

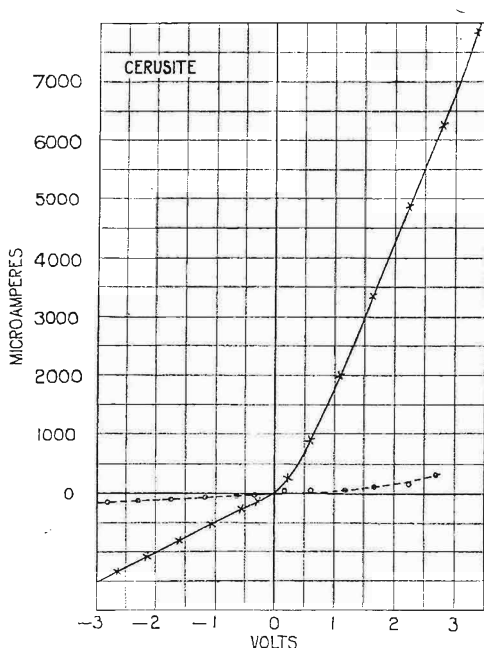

FIG. 7.—Characteristic Curve of a Crystal of "Cerusite." (A trade designation.)

of a well-adjusted combination of zincite and chalcopyrites. The dotted line shows the characteristic of another portion of the surface of the same detector. The slope of the second curve is not so great, and for this reason the detector is not so sensitive at that point. Fig. 7 shows a characteristic of the crystal which passes under the name of "Cerusite." For the three characteristic curves in this chapter the writer is indebted to "The Principles of Radio Communication," by J. H. Morecroft. New York: J. Wiley and Sons.

CHAPTER III

TUNERS FOR CRYSTAL RECEIVERS

AERIALS used for the reception of broadcast concerts are almost always of a natural wave-length shorter than that on which the concerts are transmitted. For this reason they are

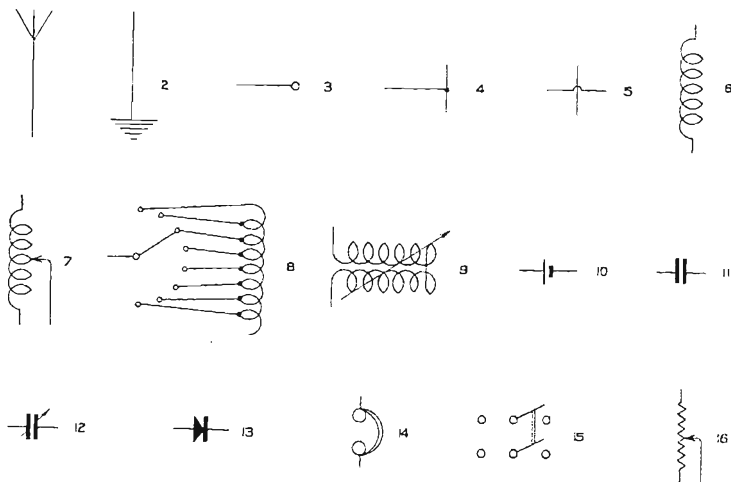

FIG. 8.—Conventional Signs used in Diagrams in this Book.
 1. Aerial. 2. Earth connection. 3. Terminal. 4. Wire joining another. 5. Wire crossing another but not connected. 6. Inductance coil. 7. Inductance coil with slider. 8. Inductance coil with tappings and switch. 9. Variometer. 10. Dry cell. 11. Fixed condenser. 12. Variable condenser. 13. Crystal detector. 14. Telephone headpiece. 15. Double-pole double-throw switch. 16. Potentiometer.

considerably out of tune for the standard broadcast waves, and to bring them into resonance, so as to obtain loudest signals, we must increase either the capacity or the inductance of the receiver. The simplest way is to add more wire in the form of a coil, in which the number of turns that can be included is variable turn by turn. This will increase the total inductance. We could increase the total capacity by lowering the aerial, so that the wires were closer to the ground, but in so doing we

should lose a great deal of the receptive properties of the wire, as these depend to a considerable extent upon the height it is suspended above the earth. If we have already a coil of wire in series with the aerial, we can increase the total capacity by connecting a variable condenser across the two ends of the coil. Frequently this is done. In crystal receivers, however, it is more efficient to obtain the wave-length by connecting a longer coil in series without a condenser across it, as although this latter will increase the wave-length, it will not give the same electrical pressure on the detector as inductance (or wire) alone.

Sometimes the aerial is too long for the reception of the signals we want. In such circumstances it is not convenient to reduce the inductance, as the practically only way this could be done would be by shortening the wire. We can, however, reduce the total capacity by inserting a variable condenser *in series*; for two condensers in series (the aerial is one) give a smaller capacity than either of them separately.

Most variable condensers consist of two sets of metal plates insulated from one another, and so arranged that one set can be gradually brought over the other. The maximum capacity is obtained when the two sets are immediately adjacent, and the minimum when they are most widely separated. A less common form of variable condenser consists of two metal tubes, separated by insulating material, and made to slide over one another. Such tubular condensers have a very small maximum capacity, but are often convenient for fine tuning.

The simplest form of tuning coil for use with a crystal detector consists of an insulating tube wound with insulated wire and supported by suitable end pieces. Above this coil is placed a metal rod, on which runs a sliding contact. Immediately beneath the contact the wire is bared by removing the insulation. The aerial is then connected to one end of the coil, and the rod carrying the slider is joined to the earth lead. The high frequency currents in the aerial will then pass through the turns of the coil until they come to the sliding contact. They will then pass *viâ* the contact to the rod and thence to earth. As the slider is moved along the rod, so will more or fewer turns of wire be connected in circuit. The more turns in circuit, the longer the wave-length to which the receiver is in tune. Fig. 9 shows such a tuning coil.

When the high frequency currents are flowing in this coil,

there will be a difference in electrical pressure across the aerial and earth terminals. If, then, we connect a crystal across these terminals, when the pressure is in one direction current will pass through it, and when it is in the other there will be

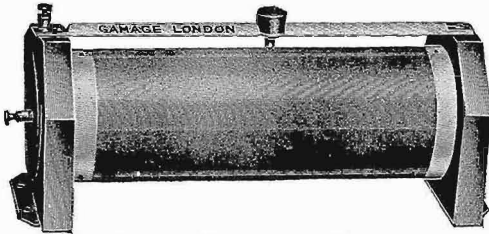

FIG. 9.—Single Slide Tuner.

By permission of A. W. Gamage & Co., Ltd.

a very high resistance to any current flow. We shall thus have uni-directional pulses of current through the crystal, and if we connect a sensitive pair of telephones in the circuit, rectified currents will pass through them. As the value of the high frequency current varies in accordance with the Morse code signals or the speech waves at the transmitter, so will the uni-directional currents through the crystal and telephones vary in sympathy. Actually the rapid pulses merge into a continuous current, due to the smoothing effect of the telephone windings, and a fixed condenser in the circuit.

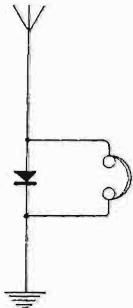

FIG. 10.—The Simplest Form of Circuit for Use with a Crystal Detector. It is very inefficient.

In conventional wireless diagrams a slider is shown as an arrow on the coil, and the detector as an arrow against a straight line. The method of depicting telephones will easily be recognised. An aerial is shown as a small fan and the earth connection as a wire at right angles to several parallel lines.

The two thicker parallel lines in a circuit represent a fixed condenser of about .001 microfarad capacity. It has been found that by connecting such a condenser across the telephone terminals better signals are obtained, although signals may be heard without it. Such

a condenser is connected in practically every efficient wireless circuit where telephones are used. In some circuits it is essential.

The simplest possible form of circuit for use with a crystal detector is shown in Fig. 10. In this case the crystal is inserted directly in series with the aerial, the telephones being connected across it. This circuit is very inefficient. As the crystal is a part of the aerial circuit, its own high resistance prevents any proper tuning being effected, and its position in the circuit is such that a minimum of pressure is applied to it.

A receiver circuit utilising a single coil, slider, crystal fixed condenser and telephones is shown in Fig. 11. This type of receiver is by far the most popular for broadcast reception as it is cheap to make and simple to operate. It is made in many forms. The crystal is subjected to the high frequency changes of pressure which occur at the terminals of the coil when the oscillations are flowing in it. Pressure in one direction only causes a current to flow through the crystal.

Practical sliders are shown in Figs. 12 to 18. The best sliders are made so that the contact is springy. Sometimes a

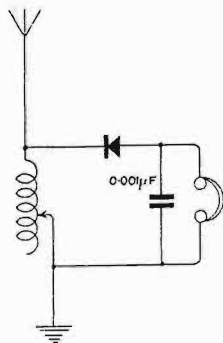

FIG. 11.—A much improved Circuit. In this the crystal does not form part of the aerial, which is thus free to resonate. The crystal is operated by the electrical pressure across the terminals of the coil.

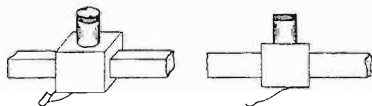

FIG. 12.—Two Views of a Simple Spring Slider with Insulating Knob.

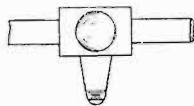

FIG. 13.—Slider with Side Projection. Another variety of the type shown in Fig. 12.

ball presses against the bared wire, pressure being applied by a concealed spring. Other sliders are made of springy brass. In every case an insulating knob is fitted to the slider, so that

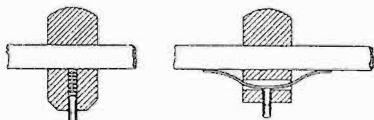

FIG. 14.—Sections of Two Sliders of a Better Type. In these the rounded end of a short rod is pressed against the wire by a coiled or flat spring.

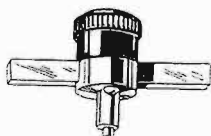

FIG. 15.— Practical Form of Spring Slider.

By permission of Radio Supplies.

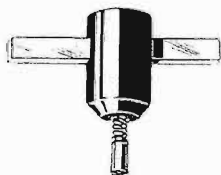

FIG. 16.—Another Type of Slider with Spring Contact.

By permission of Radio Supplies.



FIG. 17.—Slider fitted to Rack. By turning the knurled projection a smooth movement is assured.

By permission of G. Z. Auckland & Son.

the hand of the person operating the set does not come into contact with the metal. A very convenient arrangement of slider is that in which a rack and pinion adjustment is possible. Such a slider is shown in Fig. 17.

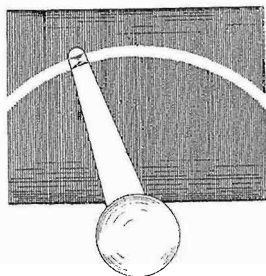

FIG. 18.—Rotary Slider for Use on Short Wide Coils.

All sliders in time wear away the wire, and unless the coil is well made, and the slider runs smoothly, accurate adjustment is difficult. A better arrangement for tuning is that by stud switches, this method being adopted in many of the better-class crystal sets.

If we wind a coil with, say, 100 turns and fit two switches, each with ten studs, we can wire it up so that any number of turns from 0 to 100 can be included at will. To do this we take a tapping from each of the first ten turns to the ten studs of

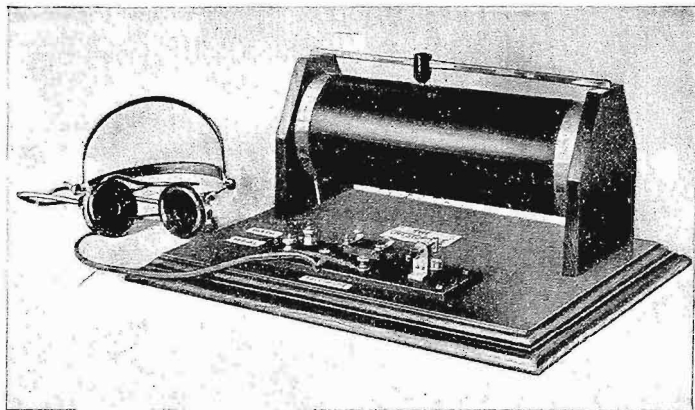

FIG. 19.—The "Crystophone" Single Slide Receiver.
The circuit is that of Fig. 11.

By permission of the Wireless Supplies Co.

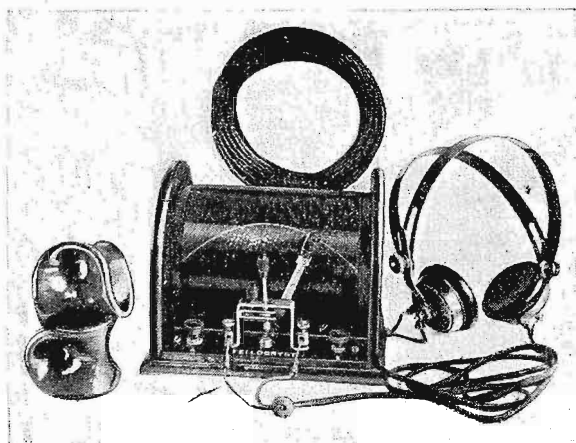

FIG. 20.—Simple Crystal Receiver utilising the Circuit of Fig. 11, and the Slider Method of Fig. 18. A coil of aerial wire is shown in the background and aerial insulators on the left.

By permission of the Fellows Magneto Co., Ltd.

CRYSTAL RECEIVERS

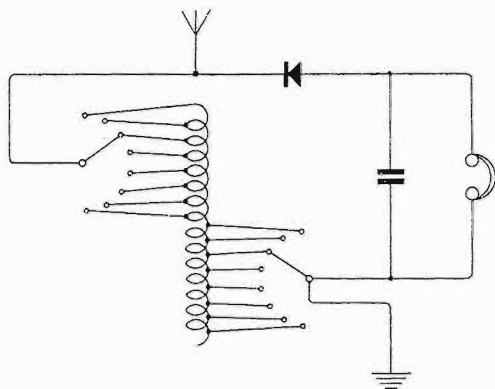

FIG. 21.—Circuit of a simple Tuner using Stud Switches. One switch is connected to studs for unit turns and the other to studs for "tens" or other suitable numbers of turns.

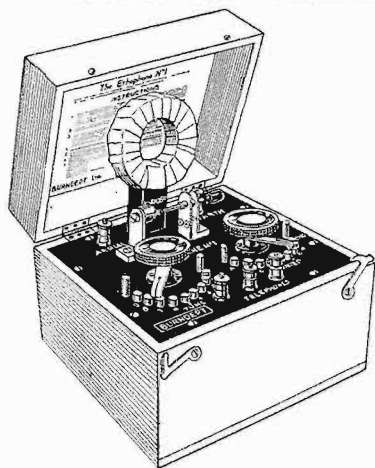

FIG. 22.—Burndept "Ethophone No. 1." A receiver with a circuit similar to Fig. 21. In addition the last stud of the right-hand switch adds the demountable coil shown at the back, thus bringing up the wave-length to 2,000 metres for Eiffel Tower time-signals.

By permission of Burndept, Ltd.

one of the switches. We then take a tapping at 20, 30, 40, 50, 60, 70, 80, 90 and 100 turns. The first stud of the second switch is connected to the same tenth turn that we have already connected to the tenth stud of the first switch. The twentieth turn is connected to the second stud, and so on, until the hundredth turn is wired to the tenth stud. Then by varying the switches we can obtain any number of turns we require. The detector is connected as before, to the aerial and earth terminals, and the rest of the circuit is the same as previously described. Such an arrangement is more satisfactory than the slider method, as, although it does not give louder signals,

it enables tuning to be more rapidly effected and there is no risk of wear on the wire. Frequently in badly-made slider sets the roughness of the slider grinds the surface of the wire, causing small metallic particles to become detached and fill the spaces between the turns, short-circuiting some of the



FIG. 23.—The Sterling No. 1 Crystal Receiver. The circuit is that of Fig. 21, with addition of the demountable coil for Eiffel Tower signals.

By permission of the Sterling Telephone and Electric Co., Ltd.

coil and reducing the signal strength. A circuit for a crystal receiver of the stud-switch type is shown in Fig. 21, while practical instruments of this type are illustrated in Figs. 22 to 24. Frequently the single-turn switch is marked "vernier" or "fine tuning."

A refinement of the slider type of tuner is that in which *two*

sliders are used. The circuit for this is shown in Fig. 25. In such cases the portion of the tuner to which the crystal is connected has more turns of wire in it than are included in the aerial. When adjusted to the highest efficiency the detector portion has a natural frequency corresponding to the frequency

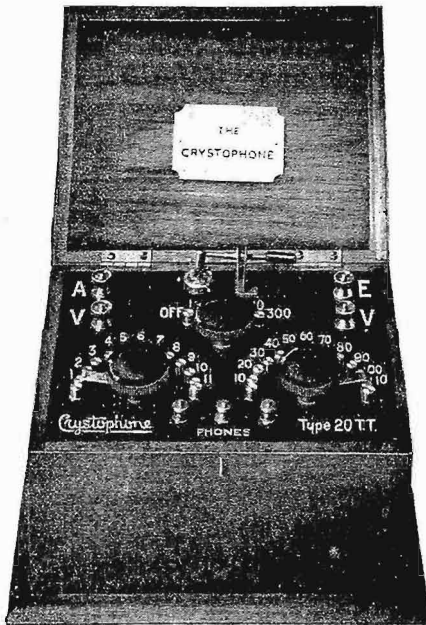

FIG. 24.—Crystophone Receiver with Stud Switches. The circuit is similar to Fig. 21, but a switch in the centre adds further inductance in large steps. The terminals V are used when a valve is added.

By permission of the Wireless Supplies Co.

of the aerial and earth circuit. In a resonating circuit, if we have a high value of inductance and a low value of capacity, we shall get a higher electrical pressure across the ends of the coil than if we have high capacity and

low inductance. The aerial has a certain amount of capacity which cannot efficiently be reduced. In a two-slider tuner the capacity of the detector portion can be kept very low, and thus we can obtain the highest pressure across the detector. Such tuners also give slightly sharper tuning, which is an advantage when jamming is annoying. Practical forms of two-slider tuners are shown in Figs. 26 to 28.

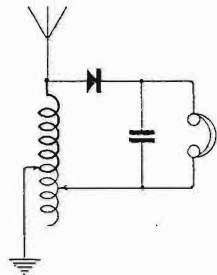

FIG. 25.—Circuit of Two-slider Tuner. The thick line shows the portion of the coil common to both aerial and detector circuits.

Three-slider tuners are sometimes found. In these two of the sliders function as explained in the last paragraph, and the



FIG. 26.—Two-slider Tuner.

By permission of A. W. Gamage & Co., Ltd.

third is used to vary the turns common to the two circuits. A three-slider circuit with two different adjustments is shown in Figs 30 and 31. If few turns are common very little energy

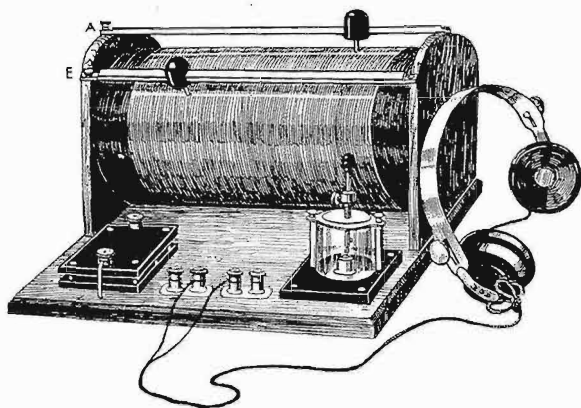

FIG. 27.—Typical Two-slider Receiver with Fixed Condenser on the Left and enclosed Crystal Detector on the Right.

By permission of G. C. Aimer & Co.

is withdrawn from the aerial at each "swing" of the high-frequency current, and when many turns are included in both circuits there is a large withdrawal each time. When the aerial has little energy taken from it on each swing a more

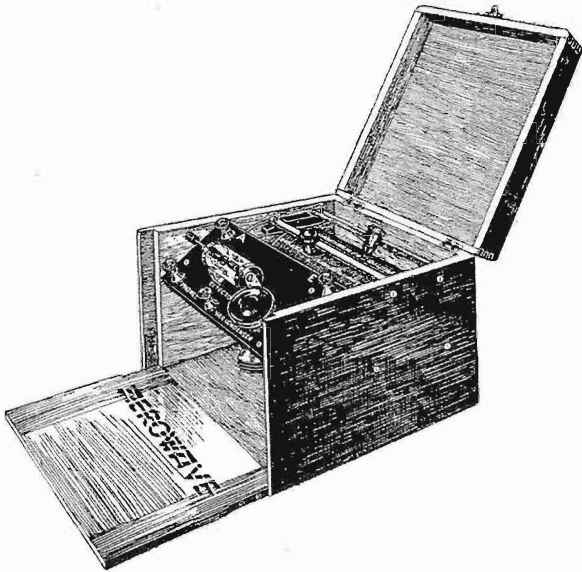

FIG. 28.—The " Aerowave " Crystal Receiver using Two Sliders and a Variable Condenser in Series with the Inductance for fine Tuning.

By permission of Henry J. Brewster & Co.

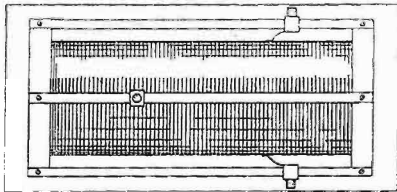

FIG. 29.—Three-slider Tuner.

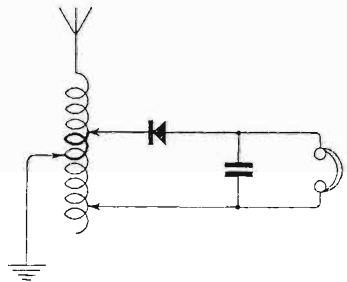

FIG. 30.— Three - slider Tuner adjusted for few Common Turns.

persistent resonance effect is obtainable. This gives sharper tuning than is possible even with a two-slider tuner. In

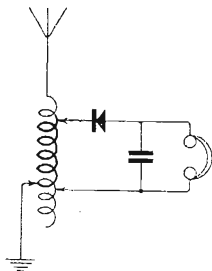

FIG. 31.—Three-slider Tuner adjusted for many Common Turns.

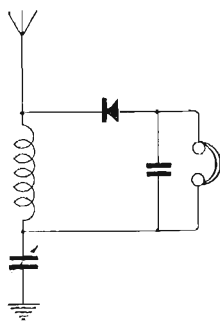

FIG. 32.—Crystal Receiver with Fixed Inductance tuned with Variable Condenser in Series.

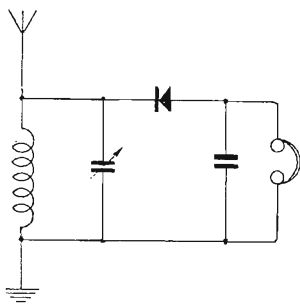

FIG. 33.—Crystal Receiver with Fixed Inductance, tuned with a Variable Condenser in Parallel.

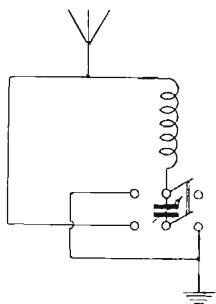

FIG. 34.—Switch for placing a Variable Condenser either in Series or in Parallel with the Inductance. The crystal circuit is not shown.

practice, and unless the set is manipulated by an experienced operator, it is doubtful whether the complications introduced are warranted by results. A three-slider tuner is shown in

Fig. 29 and circuits in Figs. 30 and 31. Such receivers cannot be recommended to the beginner, although the more advanced amateur will find them interesting

A number of variations of single and two-slider tuners are

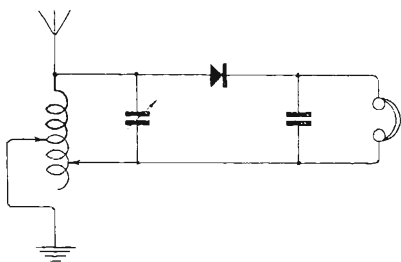

FIG. 35.—How to obtain the effect of Three-sliders with Two and a Variable Condenser.

shown in the diagrams. Where the aerial is too long a variable condenser can be introduced in series with the coil. A certain number of turns of wire are always necessary to give the requisite electrical pressure across the crystal. Series condensers enable fine tuning to be effected conveniently, but they should not be too small. A practical receiver using a series condenser for the fine tuning of the aerial circuit is shown in Fig. 28. Where it is not convenient to add further wire we can connect a variable condenser *in*

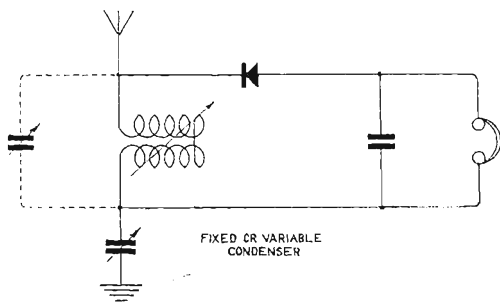

FIG. 36.—Circuit of a Variometer Tuner. The series or parallel condenser is not essential, but adds to the range of wave-length that can be received.

parallel with the coil. It is often convenient to fit a switch by which the condenser can be placed in series or in parallel with the coil. The wiring of such a switch is shown in Fig. 34.

An interesting method of obtaining a similar effect to that of a three-slider tuner with two sliders only is shown in

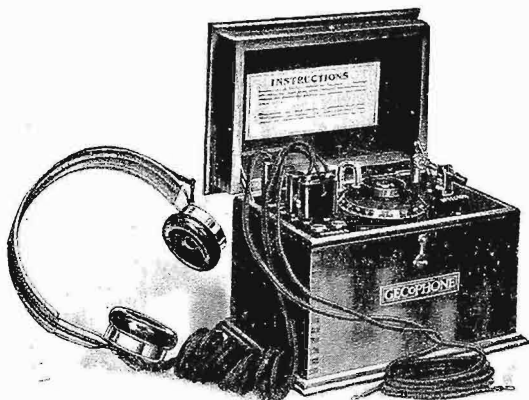

FIG. 37.—The Gecophone Crystal Set No. 1. A simple variometer tuned receiver with socket for a coil to receive Paris time signals.

By permission of the General Electric Co., Ltd.

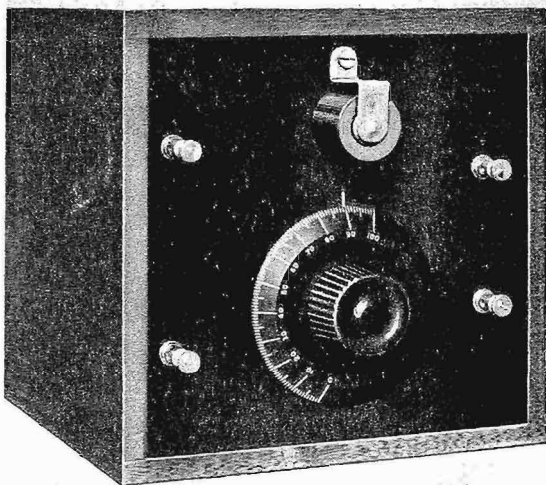

FIG. 38.—Variometer Tuner with Cartridge Form of Detector.

By permission of British Radio Sales Co., Ltd.

Fig. 35. Here the tuning of the detector circuit is effected by means of a variable condenser. The first slider tunes the aerial circuit, the second varies the number of turns common to both circuits, and the condenser adjusts the tuning of the detector circuit.

A form of tuner which has been largely used in America for broadcast reception, and which is made and sold in this country by several manufacturers, effects its inductance changes by means of an instrument known as a "variometer."

Students of electricity well know that a current of wire in

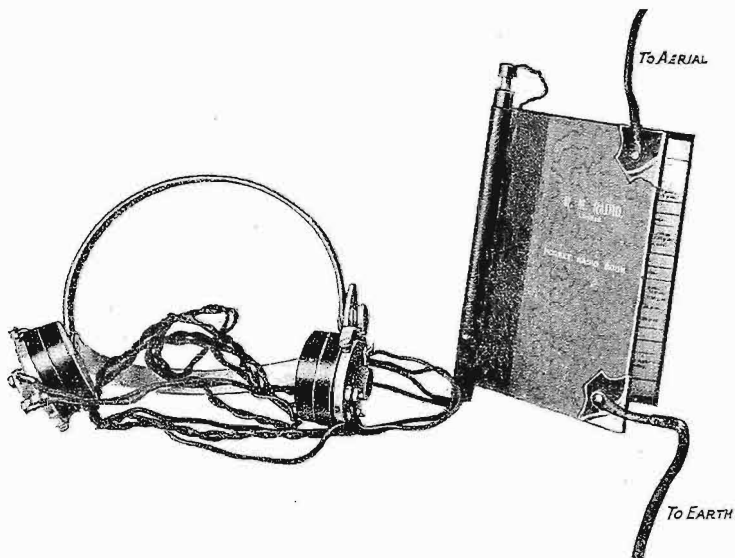

FIG. 39.—A Wireless Pocket-book, consisting of Two Flat Coils connected together and acting as a Variometer. A cartridge type of crystal detector is concealed in the back of the book. Tuning is effected by opening or closing the covers.

By permission of R. M. Radio, Ltd.

one coil will induce a current in a similar adjacent coil, and that the two currents will interact. If we have two coils each with an inductance of, say, ten units, and connect them in series with one another, the total inductance will be twenty. If, now, we place one coil inside the other, still maintaining the connection, the total inductance may be considerably more than

twenty, if the inductive effects aid one another, or considerably less than twenty if the effects oppose. If the inner coil can be made to rotate inside the outer, we can gradually change the relation of the two coils so that in one position the two inductances aid one another, and as we rotate through 180 degrees the total inductance is reduced, until at the opposite point the effects oppose and we obtain the minimum total inductance. Tuners constructed on this principle have the advantage that

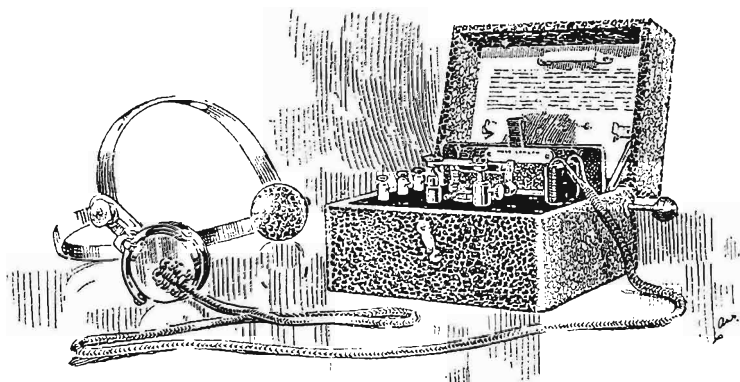

FIG. 40.—“Junior” Marconiphone Crystal Receiver. In this tuning is effected by pulling out or pushing in the rod projecting from the side of the case. There are no moving contacts, sliders or variometer, tuning being effected by the special method described in the text. Carborundum or galena crystals can be used. In the case of the former, a special device applies the required voltage to the crystal without a variable potentiometer. The utmost simplicity of operation has been the aim of the designers.

By permission of Marconi's Wireless Telegraph Co., Ltd.

there are no sliding contacts or switches. The connections for the crystal and telephones are made exactly as previously described. The circuit of such a tuner is shown in Fig. 36, and a practical instrument of this type in Figs. 37 to 39. In the Marconiphone crystal receivers the tuning is effected in a somewhat different fashion. The coil across which the crystal is placed is fixed, and has no tappings. Its inductance is, however, varied by bringing near to it a copper “spade.” As the position of this spade is varied in relation to the coil, so there is a varying degree of interaction between

CRYSTAL RECEIVERS

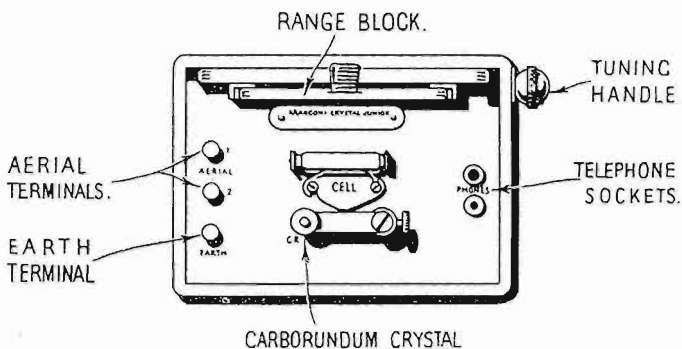

FIG. 41.—Arrangement of Parts of the Marconiphone "Junior." The "Range Block" is an interchangeable fixed inductance.

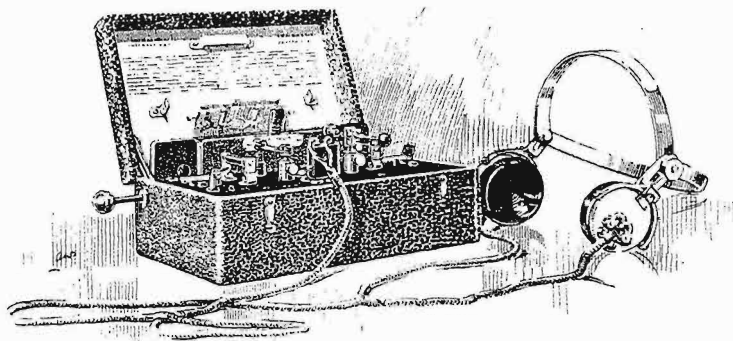

FIG. 42.—The Marconiphone "Crystal A" Set. In this the tuning method is the same as that of the Marconiphone "Junior." Two detectors are fitted—one a carborundum crystal with special device for maintaining the requisite electric pressure from a dry cell, and the other a galena crystal with ball-and-socket adjustment for the fine wire "cat-whisker."

By permission of Marconi's Wireless Telegraph Co., Ltd.

the current induced in the copper and the current flowing in the coil itself. When the copper spade is closest, the coil has the largest inductance, and tunes to longer wave-lengths. When it is withdrawn to a maximum distance the inductance

is smallest and shorter waves are received. The device thus somewhat resembles a variometer. The position of the spade is varied by a moving rod projecting from the side of the case. Marconiphone receivers are shown in Figs. 40 to 43.

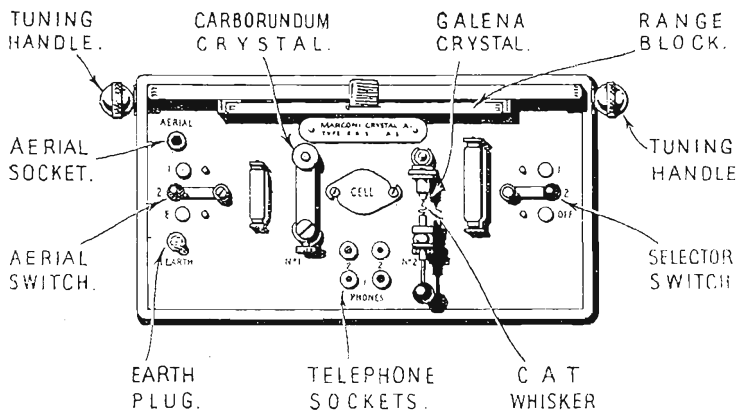

FIG. 43.—Arrangement of parts of the Marconiphone "Crystal A" Set.

There remains only to describe the type of tuner known as the loose-coupler. This form is more complicated and expensive than those previously described, and is not quite so easily manipulated. There is no question, however, that it gives the



FIG. 44.—Coils of Aerial and Detector Circuit of a Loose-coupler, both tuned with Sliders.

best results, both as regards sharpness of tuning and strength of signal.

In such tuners the aerial is adjusted either by a slider, switches or variometer, and the detector is connected to an entirely separate coil which can be made to vary its relation to the aerial coil in some convenient way. Sometimes the second

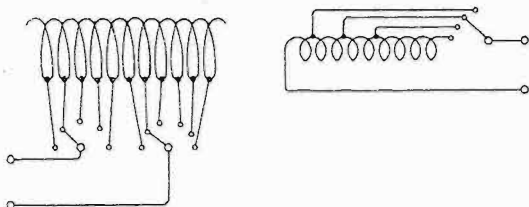

FIG. 45.—Coils of Aerial and Detector Circuit of a Loose-coupler, both tuned with Switches. The right-hand coil may slide within the left or may rotate in relation to it.

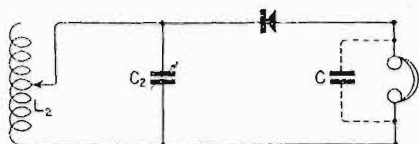

FIG. 46.—Detector Coil of Loose-coupler tuned with Inductance Steps and Variable Condensers.

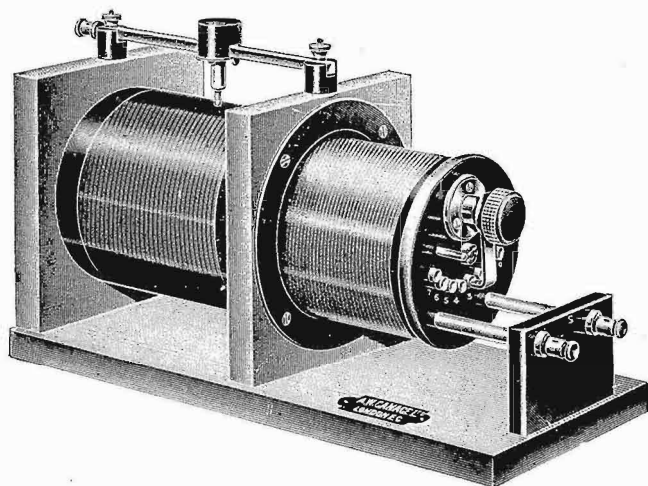

FIG. 47.—Loose-coupled Tuner.

By permission of A. W. Gamage & Co., Ltd.

coil is rotated within the first. The currents in the aerial circuit induce currents in the separate detector circuit, and a powerful resonance effect can be built up. The detector circuit is best tuned by a combination of inductance steps and a variable condenser. Fine tuning is effected by the condenser, the

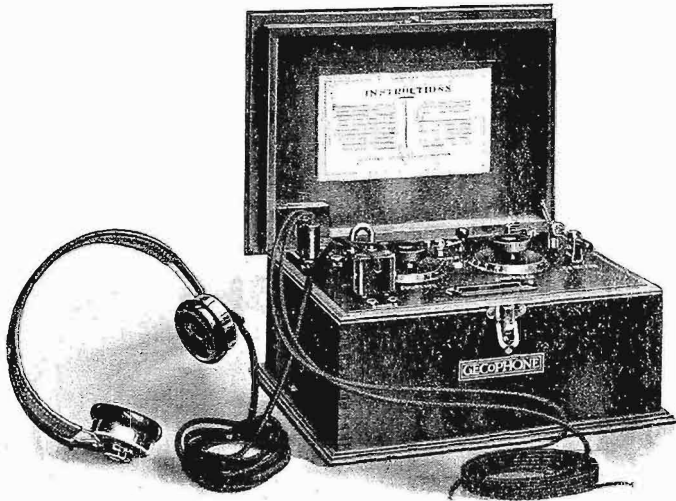

FIG. 48.—The Gecophone Crystal Set No. 2. A receiver of the loose-coupled type. The aerial circuit is tuned with a tapped switch and the detector circuit with a condenser. The coupling between the two circuits is adjusted by means of a coil which rotates within another. One of the few receivers in which a testing buzzer is incorporated.

By permission of the General Electric Co., Ltd.

capacity of which is kept as low as possible for the particular wave-length it is desired to receive.

The relation of the two coils is important. If they are too close there will be little sharpness of tuning and the strength of signals will not be satisfactory. Too far apart they will give very fine tuning but too weak signals. There is thus a critical position, found by experiment, at which there is sufficient sharpness of tuning and satisfactory signal strength for a particular station. Where signals are very loud the "coupling"

can, of course, be reduced more than where the signals are weak. The weaker the coupling the sharper the tuning possible.

Several circuits for this type of tuner are shown in the

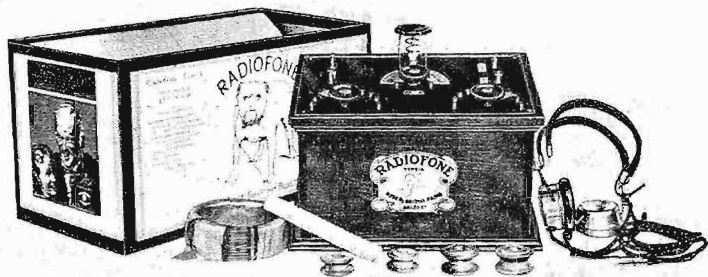

FIG. 49.—The "Radiofone." A loose-coupled type of receiver with stud-switch tuning for aerial inductance, stud-switch inductance-tuning in secondary circuit and variable condenser across latter for fine tuning. Enclosed "permanent" type detector.

By permission of British Radio Sales Co., Ltd.

diagrams, and practical instruments in Figs. 47 to 49. In some cases the aerial is tuned by a slider and the detector circuit

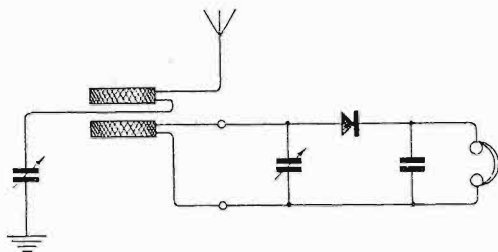

FIG. 50.—Loose-coupler circuit using "Honeycomb" "Duo-lateral," "Burndept," or other similar "plug-in" coils. Tuning in both circuits is here effected by condensers.

(or "secondary," as it is usually called) is made variable by steps by means of a switch, fine tuning being effected by the condenser.

Occasionally the reader will come across "freak" circuits, but on analysis they will be found to be nothing more than modifications of the circuits described above. On board ship, when crystal detectors are used, they are invariably fitted to

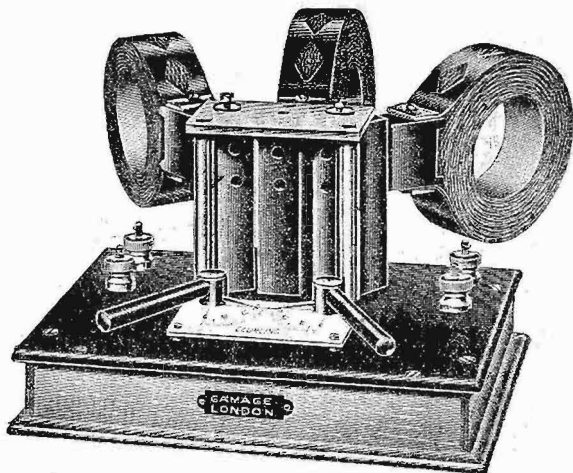

FIG. 51.—Three-coil Holder for "plug-in" Inductance Coils.

These coils enable a large inductance to be concentrated in a small space. Such a coil holder as this can be used in many ways for crystal work. Two of the coils can be joined to form a variometer, while the third can act as the "secondary" of a loose-coupler. Coupling is varied by altering the angular relation of the coil.

By permission of A. W. Gamage & Co., Ltd.

loose-coupled tuners, fine tuning in both aerial and secondary circuits being effected by inductance steps and variable condensers. In such cases the aerial tuning condenser is generally *in series*, as the natural wave-length of such aerials is large, and it is often necessary to shorten it.

CHAPTER IV

PRACTICAL CRYSTAL DETECTORS

CRYSTAL detectors are made and sold in many forms, several of which are illustrated in this chapter. The object of all is to enable a good adjustment to be obtained and maintained. In these detectors allowance is made for two main adjustments ; firstly, we have an arrangement for " searching " the surface of the crystal to find the best position, and, secondly, we have an adjustment to give the best pressure for the particular specimen.

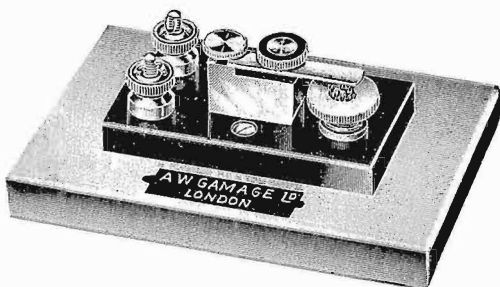

FIG. 52.—Carborundum Detector.
By permission of A. W. Gamage & Co., Ltd.

Perhaps the simplest of all crystal holders is that generally used for the carborundum type of detector, as this crystal works well without any critical pressure, by contact between some point of the crystal surface and a plate of polished steel. It is, therefore, only necessary to provide a cup or other holder for the specimen of carborundum and a support to hold the steel plate which presses against the surface. Such a detector is illustrated in Figs. 52 and 53. This general type was largely used in tuners supplied to the British troops in the late war. A type of crystal holder which attained considerable popularity before the war, and is still largely used, is that shown in Fig. 54. Whilst more elaborate than some of the others, it enables a very delicate adjustment of pressure to be made, as the pressure from the screw is transmitted through spring levers. Efficient points of the crystal can be found by moving the point from side to side.

One of the most popular forms of crystal holder, both for single crystals and a wire point, and the double combinations of the "perikon group," is that in which one crystal cup is fixed on a support and the other is carried on the end of a rod connected to a ball-and-socket universal joint (Figs. 55, 56 and 57). The ball-and-socket joint slowly carries a sliding rod

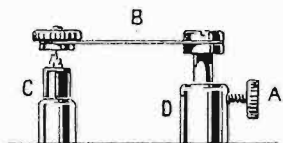

FIG. 53.—Carborundum Detector fitted to the Marconiphone Crystal Receivers.

By permission of Marconi's Wireless Telegraph Co., Ltd.

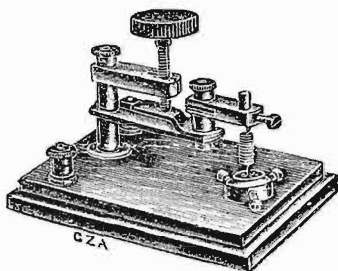

FIG. 54.—A Form of Crystal Detector which allows of very delicate Adjustment of Pressure.

By permission of G. Z. Auckland & Son.

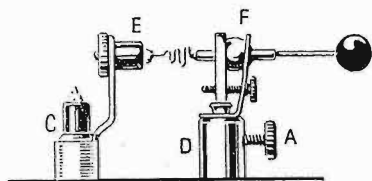

FIG. 55.—Ball-and-socket Pattern of Galena Detector fitted to the "Marconiphone" Receivers.

By permission of Marconi's Wireless Telegraph Co., Ltd.

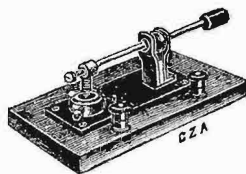

FIG. 56.—Ball-and-socket Type of Detector Holder.

By permission of G. Z. Auckland & Son.

attached to a spring, by which pressure of the wire or the second crystal can be varied. In the case of double crystal combinations, where the pressure can be firm and is not very critical, no great caution is required in adjustment, but where a wire point is used, care must be taken not to impose too great a pressure on the surface of the crystal. For those

crystal users who are experimentally inclined, detectors are made which carry a variety of crystals in various cups. The various crystals can be moved round and replaced to allow rapid

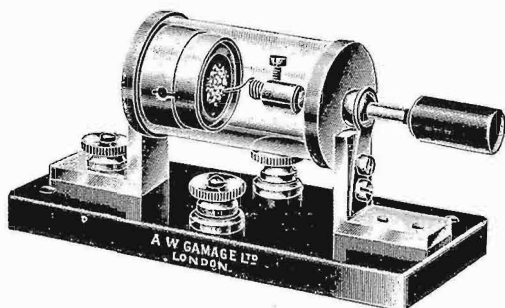

FIG. 57.—Ball-and-socket Type of Adjustment of an enclosed Detector.

By permission of A. W. Gamage & Co., Ltd.

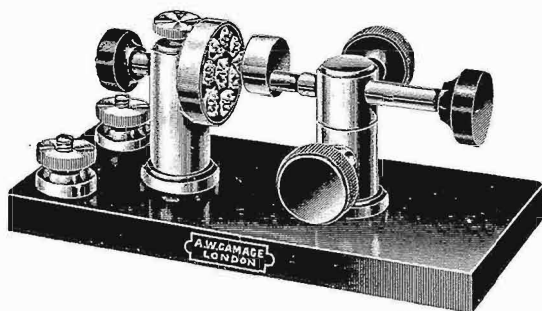

FIG. 58.—Crystal Detector permitting a Change of Crystal to be rapidly made.

By permission of A. W. Gamage & Co., Ltd.

comparisons to be made. Such a detector is illustrated in Fig. 58.

A form of crystal holder which should be avoided at all costs is that in which the crystal cup is fixed and the point or second crystal attached to a threaded rod, which is screwed forward

to meet the opposing surface crystal. Whilst to the uninitiated this may seem to be a very good method of making a fine contact, actually it is thoroughly unsatisfactory, as when the point or second crystal comes in contact with the opposite surface, a grinding effect is produced which invariably ruins the surface of one, or both, of the crystals. Such a form of detector is not sold by any reputable dealer. Many crystal

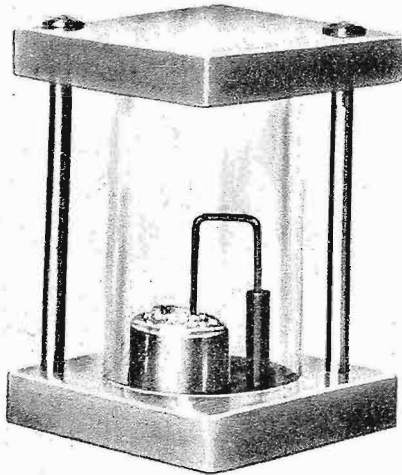

FIG. 59.—“Permanent” Type of Detector. In this form of detector the point is set on a sensitive spot and remains in adjustment for a considerable period.

By permission of British Radio Sales Co., Ltd.

detectors of types mentioned above are so made that the crystals themselves are totally enclosed in a glass or other container. This enclosing of the crystal is, in many cases, a great advantage, as it protects the sensitive surface from dust and moisture, which are always injurious.

Finally, there exist certain detectors of what may be termed the “cartridge” type. Some consist of a quantity of powdered galena in a case, and adjustment is made by rotating the case and thereby disturbing the contents. A number of

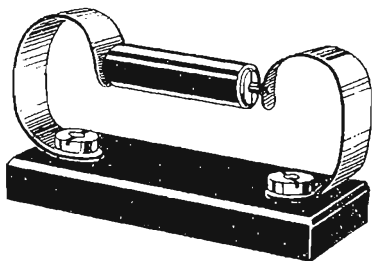

FIG. 60.—“ Cartridge ” detector in Holder.

By permission of R. M. Radio, Ltd.

these are sold in America and give quite good results in the hands of some users, but so far few have made their appearance in England. Other “ cartridge ” detectors contain two crystals pressed in contact with one another, or a crystal with a point in contact with it. Unfortunately, at the present time there is no really “ permanent ” crystal detector, although a few

can be reckoned upon to maintain their adjustment for long periods. The writer’s experience is that for all-round work there is little to beat the perikon combination, as this, having

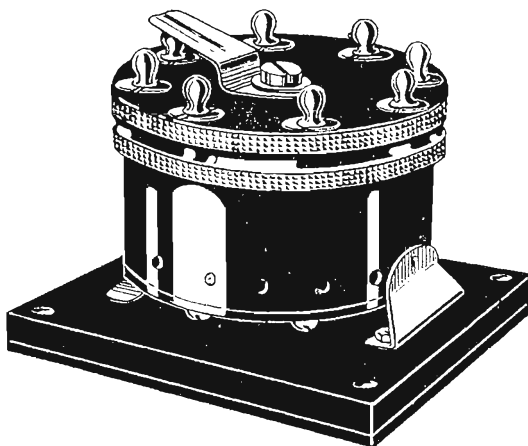

FIG. 61.—Ingenious Multiple Crystal Holder designed to obviate Trouble arising from Loss of Adjustment of Detectors in Commercial Work. There are eight separate detectors, any of which can be placed in circuit by turning the milled rim. Thus, if one fails, a fresh detector can be immediately substituted.

By permission of R. M. Radio, Ltd.

no critical adjustment of pressure, maintains its sensitivity for reasonably long periods and only requires slight readjustment from time to time. Carborundum, whilst not quite so sensitive as perikon, is remarkably constant in use, and if a good specimen is obtained it may even excel the best perikon in sensitivity. Many of the specially treated crystals sold under trade names give very satisfactory results, for whilst they are not always as sensitive as perikon or as robust as carborundum, they seem to possess a very large number of sensitive points, making the search for the new positions very easy. So much depends upon the individual specimen of crystal that it is not possible to answer the frequently asked question: "What is the best crystal for broadcast reception?"

CHAPTER V

TELEPHONE HEADPIECES

TELEPHONE receivers can be classified under two general headings, viz., "high" and "low" resistance. Crystal receivers all work best with what are known as high-resistance telephones. The terms "high" and "low" resistance in this connection are rather unsuitable, as it is not the quality of *resistance* which gives the telephones their value but the number of turns of wire around the pole pieces. When used with high resistance detectors, which allow comparatively small currents to pass through them, a very large number of turns of wire is required in the magnet windings to give the required sensitivity, and as the resistance of the coil naturally goes up with the number of turns wound on it, so windings with a very large number of turns naturally have a higher resistance than those with fewer turns of thicker wire. In valve receivers, where a steady current is passing through the windings of the telephones, in addition to the fluctuating currents due to signals, it is not advisable to use very fine wire, as very strong signals may cause the wire to burn out. For this reason, it is customary with such receivers to use a telephone transformer, the primary of which is wound with very many turns of wire,

and the secondary, connected to the telephones themselves, with fewer turns of low resistance. One thus obtains a step-down effect, and the signals in the low-resistance telephones are then quite as good as would be obtained if high-resistance telephones were used. The advantage of the telephone transformer and low-resistance telephones in this case is that the steady current from the valve passes through the comparatively robust windings of the transformer and only signal currents pass through the telephones themselves. Crystal receivers, however, have no steady current passing through



FIG. 62. — S. G. Brown Telephone Headpieces. In these an adjustment is provided for setting the reed attached to the diaphragm in the most sensitive position.

By permission of S. G. Brown, Ltd.

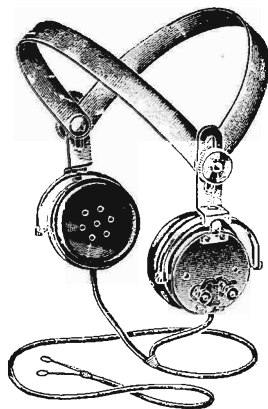

FIG. 63.—Typical Telephone Headpiece for Crystal Receivers. "The Sterling."

By permission of the Sterling Telephone and Electric Co., Ltd.

them save when they are used with a potentiometer, and even in this case the value of the current is extremely small. For this reason there is no risk of burning out the telephones, and fine-wire high-resistance windings can be used with perfect safety.

Those people who happen to possess low-resistance telephones and desire to use them with crystal receivers should connect them to a telephone transformer (this can be purchased for about a sovereign), the high-resistance winding of the

transformer being connected to the telephone terminals of the crystal receiver and the telephones themselves to the low-resistance winding of the transformer.

In those forms of telephone which have a knurled screw fitted to the earpieces, this is for adjusting the position of the reed attached to the diaphragm. The screw should be



FIG. 64.—“ Sullivan ” Telephones for Crystal Receivers,

By permission of A. W. Sullivan.

turned carefully one way or the other until a click is heard, and then turned back again slightly. This will be the best position for sensitiveness.

Very high resistance telephones (8,000 ohms or more) are made of extremely fine wire and are most delicate instruments. It is therefore wise to compromise by having telephones which are not quite so sensitive but more robust; 4,000-ohm telephones serve excellently with all crystal detectors, and even

2,000-ohm instruments give good results. For general crystal work the writer recommends telephones of about 3,000 to 4,000 ohms resistance.

It is always wise to purchase telephones of a well-known make, as a number of rubbishy receivers are sold at cut prices and are very insensitive. We are here reminded of the adage, "The strength of the chain is in its weakest link." A moment's consideration will show that the benefits of a first-class crystal receiver can be completely neutralised by a poor pair of telephones through which the signals are received.

CHAPTER VI

AERIALS AND EARTH CONNECTIONS

WHEN crystal receivers are used it is advisable that the aerial wire or wires be as large as possible within the limits allowed by the Postmaster - General. In valve receivers, where amplification can be used to make up for lack of strength, other considerations rule, but in the case of crystal receivers an endeavour should be made to raise the aerial as high as possible above the receiving instruments.

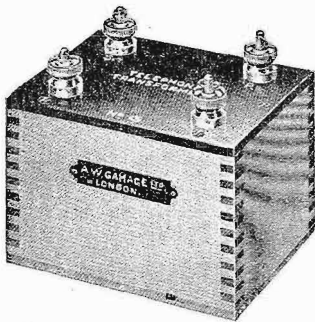

FIG. 65.—Typical Enclosed Type Telephone Transformer.

By permission of A. W. Gamage & Co., Ltd.

Information regarding ideal aerials is of little value to the average experimenter, who has to make the best of the conditions in which he finds himself. If the user has a fairly long garden, at the end of which he can erect a mast of not less than 20 feet in height, an excellent aerial can be made by taking a single wire from the top of this mast to a point as high up on the house as can be conveniently reached, and thence leading it to the room in which the instruments are situated. If the

garden is short, instead of a single wire aerial, a twin wire can be used, but the separation between the two wires should be as great as possible, 6 feet being a practical distance. Where no garden is available for this purpose, a pole may be erected on a chimney or similar support, and if conditions on the roof permit, it is better to erect two poles, one at each end of the house, and to run the wire or wires between them, the down lead being taken from one end to the instrument room. Frame, loop or other indoor aerials will give results with crystal detectors only in the immediate vicinity of a broadcasting station. Naturally the closer we are to the broadcasting station, the smaller the aerial we need use to get results.

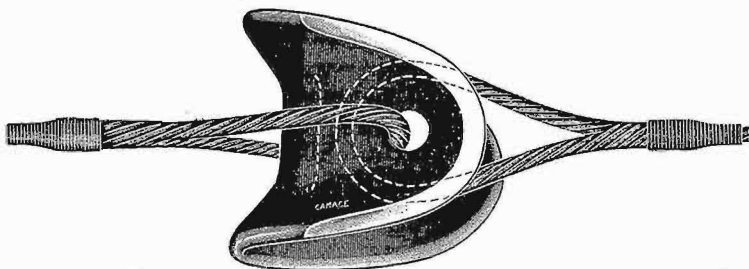

FIG. 66.—A Popular Form of Aerial Insulator.

By permission of A. W. Gamage & Co., Ltd.

Care should be taken to insulate the aerial properly. Suitable insulators for this purpose are obtainable from any wireless dealer. The "lead-in" should be taken through some form of insulating tube. If this is of the type which has some form of shield to keep it dry during wet weather, so much the better.

Every crystal receiver must have some form of earth connection. A good plan is to dig a hole in the ground and bury in it a galvanised iron plate or other large metal object to which a wire has been soldered. Where possible the earth plate should be buried in damp soil, or at least in some position where the earth surrounding it does not get too dry. An excellent earth connection can also be made on the water-pipes, which, of course, are buried in the earth outside the house.

Some books state that it is difficult to solder a wire to a lead water-pipe owing to the high heat-conducting qualities

of the lead and the fact that the pipe is full of cold water. Actually, however, very little difficulty will be experienced if the soldering iron is made very hot, the pipe scraped, touched with flux and carefully "tinned." The end of the earth lead should be similarly heated and "tinned," plenty of solder being used both on the pipe and on the end of the earth wire. This latter, if multi-stranded, may be splayed out with advan-

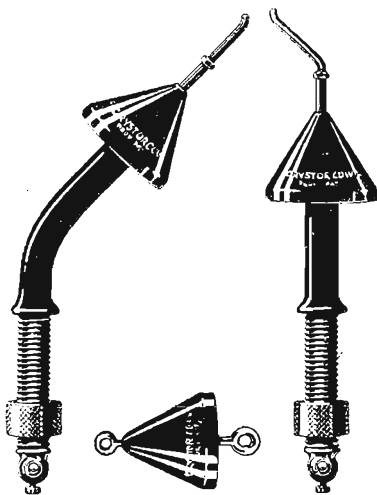

FIG. 67.—"Crystor" Cowl Insulators for Leading-in and Aerial Insulation. The curved form is used when the "lead-in" is horizontal.

By permission of Wireless Supplies Co.

tage. When both are well "tinned," again heat up the iron to a high temperature. Place the splayed end of the soldered wire on the soldered portion of the pipe and press the two together with the soldering iron. If this is done with an iron of the right temperature, the solder on both will run together into a strong, firm and sound joint.

Excellent earth clamps are now sold which obviate the necessity of soldering wires to the water-pipe. The clamps are simply placed round the cleaned pipe and screwed up tight.

Where both aerial and earth wires are brought to terminals

in the room, a convenient connection between these and the instruments can well be made by the well-known silk-covered twin-flexible electric lighting wire, the two wires at each end being twisted together so as to form one conductor. This wire, being thoroughly flexible, enables the instruments to be moved about from one portion of the room to another without the inconveniences attaching to the use of stiffer wire.

Those who have not yet purchased their wireless receiving sets are advised to make a rough sketch of the house and available ground before going to the dealer to buy their apparatus. Every dealer of repute will advise possible purchasers on the best arrangement of aerial for particular cases.

CHAPTER VII

WHAT YOU MAY EXPECT TO HEAR WITH A CRYSTAL RECEIVER

UNLESS an exceptionally high and good aerial is erected, it will be found that crystal receivers will only give good results up to a maximum of twenty or thirty miles from a broadcasting station. So far as telephony is concerned the writer does not recommend their use beyond this distance, save in those cases where the user is prepared to put up with very feeble signals. After about ten miles the signals are none too strong for many tastes. In addition to the broadcasting stations, however, there exist in this country numerous amateur telephony transmitters using about 10 watts, or less than a hundredth of the power allowed to the official broadcasting stations. A few manufacturers in the London area, however, utilise wireless telephony transmitters of a higher power than 10 watts, and these can naturally be heard for several miles on a crystal set. At the time of writing amateurs with low-power transmitters are working on wave-lengths of from 400 to 450 metres, and possessors of crystal sets in the Greater London area are advised to "listen in" on this adjustment. All "broadcast" listeners are advised to join the local wireless society even if they do not intend to take an active interest in the subject

other than listening to broadcasted music, for the secretary and members will be able to give much interesting information regarding amateur transmissions in the locality. Many visitors to the writer's house have been astounded at the amount of good telephony other than official broadcasting which takes place nearly every evening. Much of it is audible on a good crystal receiver with a well-erected and efficient aerial. The telephony transmissions from Croydon can be heard on crystal receivers by most residents in the London area. This station works on 900 metres—an adjustment which is included in many crystal receivers. Many residents on the south-east coast should be able to hear the similar station at Lympne, and there is another station of the same kind and same wave-length at Pulham, in Norfolk. The much discussed "Dutch Concerts," sent out periodically from the Hague, are quite inaudible on even the best crystal receivers with large aerials, and can only be heard with suitable valve apparatus. Again, the telephony transmissions broadcasted by the Eiffel Tower in the afternoon are equally inaudible on crystal sets as the power used for telephony purposes by both the Hague and the Eiffel Tower is comparatively low.

When we come to consider the reception of Morse signals, it will be found that crystal sets can receive over considerably greater distances than is the case with telephony. Most Morse will be heard on the 600-metres adjustment, which is included in many crystal receivers. Practically every crystal user in this country should be able to hear the time signals from the Eiffel Tower station if his tuner will allow of reception on a wave-length of 2,600 metres. Many of the receivers on the market are made to include this adjustment, either by pushing the slider or switches to the end of their range or else by plugging in a special coil which will bring the wave-length up to the required figure. By reference to the Appendix it will be seen that not only does the Eiffel Tower send out time signals, but also meteorological messages. These are all sent at a comparatively low rate of speed, and are therefore useful for those whose knowledge of the Morse code is not great. Furthermore, it is possible that this country will broadcast certain useful information by wireless *telegraphy*, as has been very successfully done in the United States. While telephony is, of course, much easier for the ordinary man to read, yet the range of a telegraphy transmitting station for a given power is much greater than that of a telephony trans-

mitter. The reader is therefore advised to make himself acquainted with the Morse Code (see Appendix), practice in which can always be obtained at the local wireless society.

CHAPTER VIII

HOW TO ADJUST A CRYSTAL DETECTOR

If the user of a crystal receiver is within comfortable range of a broadcasting station, and is acquainted with the time of working, he can vary his adjustment until the best results are obtained, using the actual telephony being transmitted for the purpose. Many users, however, will prefer to have their apparatus adjusted to the maximum sensitivity before the hour for broadcasting arrives, and as no crystal receiver will maintain its sensitivity indefinitely without readjustment (some of the most sensitive crystals require the most frequent adjustment), the following hints may prove useful.

Every commercial wireless station using a crystal receiver is provided with a small testing buzzer. The testing buzzer resembles in construction an ordinary electric bell, save that there is no hammer or gong on which the hammer strikes.

In principle it consists of an armature which is attracted towards an electro-magnet. As soon as the armature is moved towards the magnet poles the circuit is broken, no current flows through the windings, the magnetism ceases and the armature flies back to its original position, once more making contact. Naturally, as soon as contact is again made, a current flows once more through the windings, the armature is attracted again, and the same cycle of operations is repeated. The effect of this is to cause a rapid vibration of the armature, depending upon the stiffness of the spring and the size and weight of the moving parts. Small light armatures with fairly strong springs will vibrate at a high rate of speed, producing a musical note.

Now every time the contact is broken by this vibration, a tiny spark takes place between the movable and fixed contacts. This tiny spark discharge generates extremely feeble wireless waves, which radiate into the surrounding space and are strong

enough at a short distance to affect a crystal or other detector. If, then, the buzzer is connected to one or two dry cells and set vibrating in the immediate vicinity of a crystal detector, a buzz will be heard in the telephone corresponding to the buzz of the vibrator. If the contact wire of a crystal detector is now touched upon various portions of the crystal, a point will soon be found where the buzz is heard with maximum strength, and this is the best point of adjustment for sensitivity.

The buzzer should not be placed too close to the instrument, or the current in the windings may induce an effect in the windings of the telephone, quite apart from any effect of the

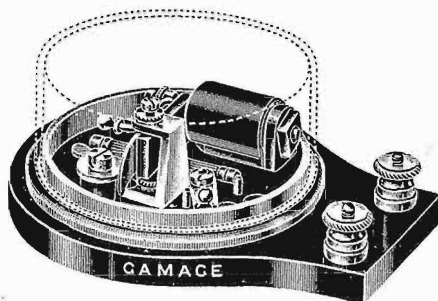

FIG. 68.—A Crystal-testing Buzzer.

By permission of A. W. Gamage & Co., Ltd.

feeble wireless waves on the detector itself. It is a good plan to take a wire from one or other of the terminals of the buzzer (the better of the two is found by trial) to the earth connection. The buzzer can then be moved from the immediate vicinity of the receiver and the wire will conduct to the crystal just sufficient impulses to enable it to be adjusted to the best degree of sensitivity.

Wireless dealers sell suitable buzzers for this purpose, although one can be improvised from an electric bell of the ordinary type. Remove the gong and cut off the hammer close to the armature so that this latter may be kept light and free to vibrate at the highest possible speed. Screw up the contact as close as possible without sticking. Adjustment is always better with a high musical note than

with a low, rough note of a slowly vibrating armature. The reader is advised to purchase a proper testing buzzer, as these are usually made in such a way that they give a clear, high note. The dealer from whom the buzzer is purchased should be asked how many cells are required to work it. Many work satisfactorily on one dry cell and the majority with not more than two. Do not use more cells than the buzzer is designed for, as, although a greater strength of buzz may be obtained, the contacts will wear out much sooner and probably stick and be spoiled by the tiny arc which forms when too much current is passing.

Always bear in mind that the surface of a crystal must not be touched with the finger. If this is done a slight film of grease, quite invisible to the eye, but nevertheless highly injurious, may be formed on the surface and effectively prevent a sensitive adjustment being obtained. Again, treat the surface with the greatest care, as sensitive points are easily spoiled by rough handling and scratching with the contact wire. Contact usually needs to be of the lightest possible character, and the wire should never be drawn or rubbed across the surface. If one point is found to be either insensitive or not sufficiently sensitive, lift the wire and replace on the crystal at some other point, making a regular search until the best position is found. Some crystals are peculiarly liable to have their sensitivity upset by vibration of the contact; others, such as carborundum and perikon, will maintain their adjustment even with considerable vibration. Galena, molybdenite, iron pyrites, and practically all crystals which work with fine wire contacts, should be so set that the wire just rests on the surface with the minimum pressure. The pressure may be firmer with silicon. Contact between double crystals, such as zincite and bornite or the other "perikon" combinations, can be quite firm. Remember, too, that all crystals of the same kind are not equally sensitive, and if a thorough search does not reveal a good point, try changing the crystal. The perikon detectors are usually fairly sensitive over the whole surface, although some points are always better than others. Galena, on the other hand, although very sensitive when a good point is found, has many spots which are entirely insensitive.

Last of all, do not expect too much from any crystal detector. Many users get dissatisfied with the signals they are receiving, and in the constant endeavour to find better points than are to be found even on the best specimens of the particular

crystal, wear away the sensitive points which *do* exist by constant re-adjustment. If, however, the speech or music is heard reasonably strong, leave the detector as it is, and content yourself with the point you have found. When using a carborundum detector which requires adjustment by means of a potentiometer, first of all, with the potentiometer switched off, test with a buzzer until the most sensitive point is found. Then leaving the crystal as adjusted, carefully vary the potentiometer until loudest signals are obtained. In this way the best adjustment of the detector is found in the shortest possible time. Do not attempt to improve matters by altering the contact while the potentiometer is on. The carborundum detectors used in the Marconi phone crystal sets are so constructed that the crystal is automatically maintained at the right potential without any adjustment of a special potentiometer.

CHAPTER IX

MAKING SIGNALS LOUDER

SOME beginners in wireless are under the impression that if they wish to improve their receiving so as to have the signals

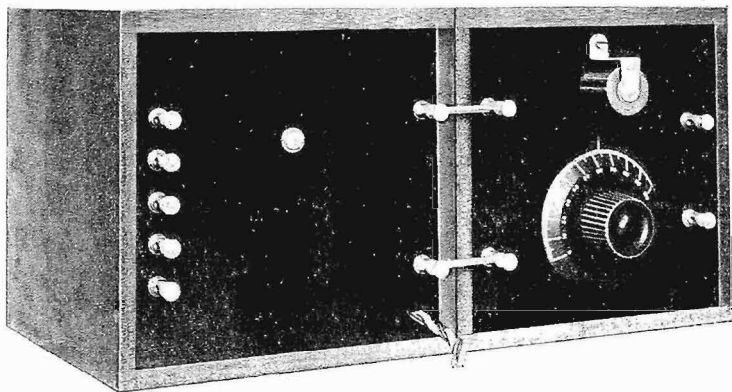

FIG. 69.—Variometer Type Crystal Receiver, with Single-valve Magnifier added as a separate Unit. The valve is concealed with the left-hand box.

By permission of British Radio Sales Co., Ltd.

sufficiently loud to operate a loud speaker, they must discard their crystal apparatus and purchase a new set with valves. Whilst it is true that no crystal receiver unaided will operate a loud speaker or give signals sufficiently strong to be heard with the telephones off, valve amplifiers can be added



FIG. 70.—Variometer Tuned Receiver, with enclosed Crystal Detector and built in Single-valve Magnifier. Such a receiver will give far stronger signals than can be obtained with the best crystal alone.

By permission of British Radio Sales Co., Ltd.

to any good crystal set with excellent results. Those who have good quality crystal receivers can use them for loud-speaker work by purchasing a two-valve note magnifier, either as two separate magnifying units or built into one box. Within ten or fifteen miles of a broadcasting station, and on a good aerial, a two-valve note magnifier, connected with a good crystal

receiver, will give speech and music comfortably audible throughout a moderate-sized room. While writing on this subject, it cannot be too strongly emphasised that a loud speaker is not in itself a magnifier. The majority of them consist merely of a good quality single earpiece attached to a suitable horn or trumpet, and indeed attachments are sold which can be connected to a pair of telephones so as to convert them into a loud speaker. To get really satisfactory results on a loud speaker the signals must be too strong to be comfortably audible in a single pair of telephones, and unless they are so it is waste of money to purchase one.



FIG. 71.—A Well-known Loud Speaker (the S. G. Brown).

By permission of S. G. Brown & Co., Ltd.

Even the best loud speakers give a certain amount of distortion to speech and music. Some of this is undoubtedly due to the amplifiers which must, of necessity, be used to make signals sufficiently strong. As a general rule, it may be said that to make signals audible in a room with a loud speaker we must add a two-valve magnifier to the set we have previously used to give comfortable strength in the telephones.

CHAPTER X

HOW TO BUILD A CRYSTAL RECEIVER

WHILE there are many ingenious and thoroughly satisfactory crystal detectors on the market, many readers will desire to construct for themselves such a piece of apparatus. In so doing they have a choice of several types, of which, perhaps, the simplest is a coil with single slider, mounted on a base which carries the detector, fixed condenser and necessary terminals.

This type, however, unless very carefully made, rarely gives the result expected of it, as any slight irregularities in winding the coil prevent the proper action of the slider. Again, unless the former, on which the wire is wound, is perfectly smooth and regular, and of a material which is not likely to warp, it

is extremely difficult to make the slider run truly. For this reason, unless the reader is prepared to take a good deal of trouble, this type of construction is best left to manufacturing firms who have the proper facilities for turning out such apparatus.

Although more trouble to construct, there is no question that a far more satisfactory method is that in which tuning is affected by means of stud switches. Incidentally it will be noticed that many of the better types of apparatus on the market are constructed along these lines. The soundness of the design is attested by the fact that when the United States Government wished to circulate instructions on how to make satisfactory receivers for broadcasting, they chose this type for description in a pamphlet issued a few months ago by the United States Bureau of Standards.

The piece of apparatus shown in use on the cover of this book, and in more detail in the frontispiece, was recently built by the writer for the purpose of producing a simple and efficient set to cover the broadcasting wave-lengths and to include the Eiffel Tower so that daily time signals might be received with its aid. Every part is readily obtainable from any wireless dealer, and the total cost of all material should not, at an outside estimate, exceed a sovereign. The external coil, if purchased complete, will cost about 10s. more. This latter is unnecessary if time signals are not required.

To complete the receiver, the following materials are required. No prices are given nor exact measurements, as both will vary greatly with the individual taste of the constructor and the quality of the materials he desires to use.

(1) Ebonite panel, approximately 9 inches \times 5 inches and $\frac{1}{4}$ -inch thick. Whilst the use of ebonite is strongly recommended for the panel it is not absolutely essential, and good results can be obtained with dry wood or vulcanised fibre. However, as it is most likely that the user will proceed from this set to a valve set, in which insulation is of the greatest importance, it is wise to use ebonite from the beginning, quite apart from the fact that this material adds greatly to the appearance of the finished set.

(2) Two switches with necessary nuts and washers. The arms should have a radius of about $1\frac{1}{2}$ inches. A variation from this figure is, of course, allowable.

(3) Twenty switch studs, with nuts and washers (6 B.A.). These studs are sold in several heights, and are best purchased

at the time the switches are bought. If this is done, the reader can make sure that the height of the studs is correct for the particular switch arms which will be used on them.

(4) Seven terminals with nuts (4 B.A.). They should be of the kind pierced with a hole for a wire.

(5) One short length, about 1 inch or $1\frac{1}{2}$ inches of brass rod of such a size that it will pass readily through the hole in one of these terminals. This can be cut from a brass dresser-hook, or a pin-type "Gibson" terminal will serve excellently.

(6) Two washers of a size to fit over the stem of one of these terminals.

(7) One crystal cup with tapped hole and metal screw to fit.

(8) Four high contact-studs with nuts and washers. These are to act as stops for the switch arms.

(9) Eight brass screws about 1 inch long.

(10) One small piece of ebonite about 1 inch \times 3 inches. A piece of this size can be cut from an oddment, and can probably be obtained from a dealer for a penny or two.

(11) One plug, as used for detachable coil mounting.

(12) One former, preferably of ebonite, but quite satisfactory if of waxed cardboard, about $3\frac{1}{4}$ inches long, 3 inches or $3\frac{1}{4}$ inches external diameter.

(13) Quantity of No. 24 S.W.G. cotton or double-silk covered copper wire, sufficient to fill this former when completely wound.

(14) One fixed condenser of .001 microfarads capacity.

(15) Small quantities of shellac, varnish and solder and flux.

(16) One galena or other similar crystal. Many excellent crystals are sold under fancy trade names, such as Hertzite, Cerusite, Radiocite, etc. Practically any of these will give good results.

In addition to the parts named above, a wood case is necessary. This can either be purchased ready-made, made up for the reader by the local carpenter, or constructed at home by those who have a taste for woodwork. It should be so made that the panel can be screwed on to the base and two upright portions, leaving the back and top to be attached after the wiring has been practically completed. Naturally, the appearance will be enhanced if the cabinet is constructed of mahogany, walnut or some other fancy wood, but thoroughly satisfactory instrument cases can be constructed of plain white wood subsequently finished with stain and varnish.

In designing the set, great care has been taken to avoid the

necessity of any screw thread cutting by the builder and very few tools are required. The following are all that are necessary:—

(1) American twist drill with two Morse drills of different sizes. The first of these should be a "clearance" drill for a 4 B.A. metal screw. The second drill should be of such a size as to give clearance room for the spindles of the switches.

(2) One soldering bolt.

(3) Pair of wire-cutting pliers. An old pair of scissors will do almost as well for this work.

(4) One small smooth file.

(5) Screwdriver.

(6) Two sheets of fine emery paper.

(7) Small centre punch and hammer.

For those who have not a hack saw for cutting the ebonite, and are unaccustomed to deal with this material, it is advisable to purchase the panel ready cut to size. It will be found that a panel 9 inches \times 5 inches \times $\frac{1}{4}$ inch will weigh exactly $\frac{1}{2}$ lb. The cost of this panel can therefore be found by referring to any dealer's list, taking the current price of ebonite per lb. and adding a small additional charge for cutting to size.

Ebonite when sold has a bright polished finish on its surface, but this has poor insulating properties. The first step should be to remove this surface or skin by placing the panel on the table, taking a small piece of fine emery and carefully rubbing over the whole surface with a circular motion. If this is carefully done an excellent matt finish will be obtained. The appearance of the ebonite after it has been rubbed over with emery will be a rather dirty brown owing to the fine dust created. This should be cleaned off, and the black surface restored by rubbing with a duster, on which has been placed a very slight touch of vaseline or oil. Only the merest trace is necessary. The edges of the panel can be smoothed by fastening a piece of emery to a small flat piece of wood and rubbing the edges until the desired effect is obtained.

It will be noticed from the illustration that the layout of the panel is perfectly symmetrical. No difficulty will be found in marking out the panel on the back where scratches or markings do not matter. In this connection it should be mentioned that in no circumstances should lead-pencil markings be made on the ebonite, as these are semi-conducting in nature. If, therefore, a pencil line joins two

terminals in the finished instrument, the current will leak between them, and in valve apparatus this leakage is often quite sufficient to make the set inoperative. If guiding lines are required, it is therefore best to make them by scratching. This does no harm if the scratches are light and are made on the back of the panel.

First of all mark out the positions of the terminals by means of some sharp-pointed instrument such as a centre punch or nail. Then having marked the positions for the centres of the switches, scratch semi-circles of a radius equal to that of the switch arm. Next with a pair of compasses or dividers mark equal points along these curved lines for the centres of the contact studs. In marking out the positions the space between the successive studs should be slightly less than the diameter of the stud faces, and should of course be slightly less than the width of the switch arm, or there will be a danger of this latter falling between the studs. Eight points should also be marked near the edge of the ebonite for the screws which will hold the panel to the wood work. Four marks should be made for the holes for the high studs which will act as stops. These holes, however, are best made after the studs have been fitted in place and the switches mounted, so that they can be made to check the switch arms in the right position. A mark should also be made for the hole to take the screw which will grip the crystal cup. When the panel has been laid out in this fashion, drill the holes. It is well to practise drilling with a spare piece of ebonite before commencing on the panel as, although the work is by no means difficult, mistakes are not easy to rectify, and the constructor should first of all acquire confidence in his handling of the drill. The pressure used when drilling should not be heavy, or there will be a tendency for the ebonite to break away from the hole as the drill passes through. This breaking away can be avoided by drilling on an odd piece of ebonite, but if no odd piece is available for this purpose, any piece of good hard wood will do, provided it is perfectly level.

The holes round the edge of the ebonite, for the purpose of securing it to the woodwork, may with advantage be counter-sunk. Where no counter-sink is to be had, a plain hole can be drilled and round-headed wood screws used for securing the panel. When the holes are drilled, fit the studs in place and secure them with lock nuts. For the moment leave the other parts unassembled. Then lay a new sheet of emery on

a flat board, turn the panel face downwards on this emery, and rub it over the surface of the emery paper with a circular motion. This will grind the faces of the studs perfectly

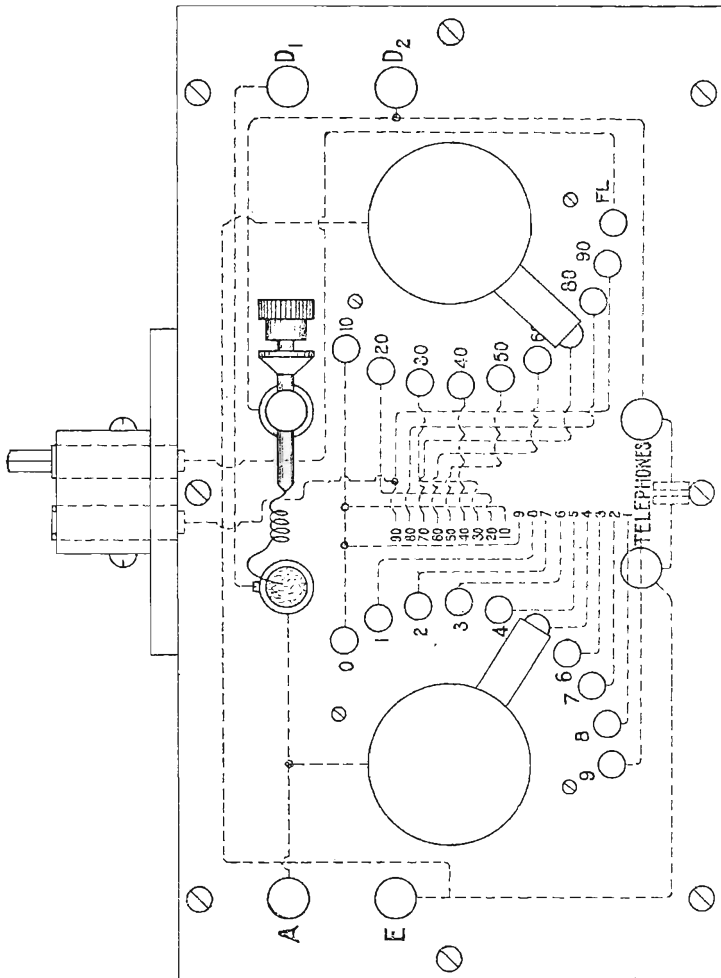

Fig. 72.—How the Crystal Receiver is Wired. For simplicity of illustration the coil itself is omitted. Dotted lines are taken from the studs and terminals to numbered points which correspond to the tapings on the coil. With this diagram before him the builder will have no difficulty in "wiring-up."

smooth so that the switch blades will run over them with the necessary smooth action. When this has been done the switch arms, stop terminals and crystal cup may be fitted. The portion of the crystal detector which carries the "cat-whisker" wire consists of a pin-type terminal fitted with a washer on each side of the panel. To secure it in place slip the washer (the bigger the better) over the threaded portion of the terminal, push it through the panel, place a second washer on the inside, screw up one nut as far as it will go without tightening it, and then run on a second nut until it reaches the first. Then, holding the first nut, grip the second with a small spanner, pliers or some such device, and twist it tightly against the first so that the two lock tightly. This will allow the terminal to rotate in its hole without being loosened. Next take the short piece of brass rod (a dresser hook will do), file it smooth on each end, procure a short length of fine copper wire (about 30 S.W.G. is excellent), about $1\frac{1}{2}$ inches in length, coil it round a lead-pencil and lay by, together with the brass rod, until soldering is commenced.

Next take the small piece of ebonite, finish it with emery, mark on it the position of the holes which will allow the screws of the coil holder to pass through it, and attach the latter by the two screws provided with the plug. These should pass through the ebonite from below.

When these details have been attended to, take the ebonite former, and pierce it about $\frac{3}{16}$ inch from one end with two small holes. Now take the end of the No. 24 wire, pass it from the outside through one of the holes, and back through the other, securing in place with a touch of sealing wax. Then begin winding. Wind one turn of wire and, holding the turn in place, make a small loop and twist it round in the fingers so that the loop projects. Then make a second turn and form a second loop in the same way. The second loop, however, should be made slightly in advance of the first so that it will be "staggered" when the coil is finished. Now make eight more turns each with a loop, the loops being regularly spaced as explained. When the 10th loop has been made wind ten "plain" turns and make a loop at the 20th. Follow the same procedure, making loops at the 30th, 40th, 50th, 60th, 70th, 80th, and 90th turns. This will nearly fill the former. When the 90th turn has been completed, place a touch of sealing wax on the coil to hold the wire in place. Drill two more holes similar to those at the beginning and pass the wire through

them, leaving about an inch projecting. When the coil is finished a few touches of sealing wax here and there will secure it in place, or better still, it should be brushed over with a good shellac varnish and dried in a warm (not hot) oven. If this is done, the wire is effectively protected from moisture and will not loosen even if the former should shrink very slightly. Another alternative is to paint it over with melted paraffin wax. Of the two methods, shellacing is to be preferred.

If the highest efficiency is to be obtained with apparatus of this kind, it is desirable for all connections to be soldered. All soldering can conveniently be done at the same time. While the soldering bolt is heating, take a smooth file and lightly file the tops of all screws protruding through the back of the panel. Also scrape the insulation from each of the loops on the coil. Then with a match stick, put a *very light* touch of good solder paste on each of the terminal points and on the bright scraped wire of the loops. The very smallest touch of paste will suffice. When the soldering bolt is properly heated, it should be "tinned" by touching it with flux and rubbing it with solder. The bolt should then be held on each of the filed points in turn for about five seconds, when, if the process is properly conducted, a tiny drop of solder will adhere to each. The loops should also be touched in the same way, so that they may receive a small deposit of solder.

As soon as this preliminary tinning operation is completed, go over all nuts and re-tighten them, as in practically every case it will be found that heating a screw has slightly loosened it. Next get nineteen lengths of wire, each about 7 or 8 inches long, and tin each end as before. Connect up these terminals on the panel which are shown connected together in the diagram on p. 63, coiling a few turns of the wire which is attached to the moving portion of the detector. This will prevent the wire being loosened by the continual motion of adjustment.

Now take the nineteen lengths of wire above referred to, and with the heated soldering bolt, press them into contact with the studs shown. If the bolt is sufficiently hot this operation is readily performed without the studs being sufficiently heated to loosen them again. Should any become loose they can of course be tightened before proceeding with further work.

The fixed condenser should now be secured to the back of the panel and connected across the two terminals. How this

is done will depend upon the kind of fixed condenser purchased. If it merely consists of sheets of mica and copper foil, with lugs projecting at each side, two holes can be cut in the lugs, and these slipped over the stems of the terminals and held

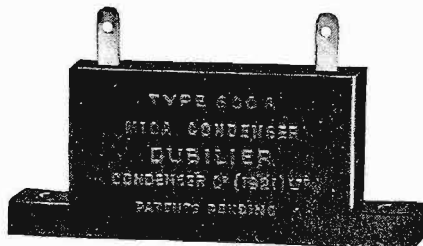

FIG. 73.—A Fixed Condenser composed of Thin Sheets of Copper Foil separated by Sheets of Mica, the whole being imbedded in a special Insulating Compound.

By permission of the Dubilier Condenser Co. (1921), Ltd.

in place by nuts. If the condenser is cased, it may be well to secure it to the base board and take leads from it to the necessary terminals.

Next make or obtain a base board, with two uprights secured

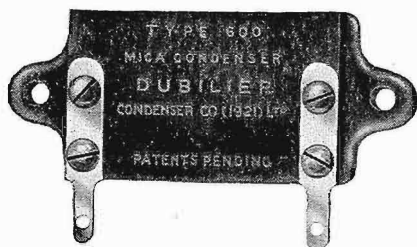

FIG. 74.—Another Form of Mounting for a Fixed Condenser.

By permission of the Dubilier Condenser Co. (1921), Ltd.

in place, and screw the panel to its supports. The next step is to attach the coil former, in a vertical position, to the base board. This can be done by several methods, one of the simplest being to cut a piece of wood of such a size that it will fit into one end of the former. Secure the former to this piece

of wood by small brads or screws and pass a single wood screw through the end piece into the base board. The coil should be secured in the centre of the base board with the tappings in the rear. Now take the loose wire from the lowest stud of the right hand switch (viewed from the back), bring it round so that it will just reach the bottom end of the coil, cut it off with about 1 inch to spare, bare its end and with the soldering bolt heated, tin the end as previously described. Perform this operation with the nine remaining wires on this side, then deal with the wires from the nine points of the left hand switch. The tenth or upper point, it will be noticed, has already been secured to the top stud of the opposite switch. When these nineteen wires have been tinned, turn again to the right hand switch, and with a touch of the hot solder bolt secure the wires to the tappings indicated. The wire on the bottom stud of the left hand switch is for the moment left free.

Now take the piece of wood which is to form the top of the box, and cut a large hole, about $1\frac{1}{2}$ inches long \times $\frac{1}{2}$ inch or $\frac{3}{4}$ inch wide, in the middle of it. It does not matter if the hole is cut roughly, as it will be covered up by the ebonite top piece. Now screw the ebonite piece in place with two wood screws and lay it by.

The back of the box should now be screwed in place, and about 8 inches of wire soldered to the top end of the coil at the join where the last tapping is made from the left hand switch. Take this wire and the wire from the bottom stud of the left hand switch and join them to the terminals on the underside of the plug socket. It does not matter if the wires are rather long, as the loose leads will lie within the box. They may be tinned and soldered, or the wires may be held in place by the screws themselves pressing against washers. It only remains now to screw the lid in position and the interior of the instrument will be complete.

Now take the short length of brass rod and the length of fine wire and solder one end of this latter to the end of the brass rod. When this is done and without troubling to bend the fine wire into any particular shape, pass it through the moveable pin terminal. It will add to the appearance of the instrument if a small knob is attached to the end of this rod after it has been passed through the terminal. A small piece of ebonite rod, for example, can have a hole drilled in the centre of it and be pressed on.

When this work is completed the wood cabinet can be

finished with a suitable varnish stain, if of white wood, or otherwise finished according to the tastes of the user.

All that now remains is to fix the crystal in place in its cup by means of the locking screw provided. It is wise to wrap the crystal, with the exception of the upper surface in a piece of tinfoil before locking it with the screw, as this helps to make good contact all round. If preferred it can be fixed with Wood's metal. The fine wire on the rod of the detector should now be bent into such a shape that it can be made to bear upon the surface of the crystal by rotating the rod in its hole. If this is done it will be found easy to "search" the surface of the crystal, either by pulling the rod through its hole or by swinging the movable portion.

Looking at the instrument from the front, the two terminals



Fig. 75. — Crystal Cup with Three Locking Screws.

By permission of A. W. Ganage & Co., Ltd.

on the left are for the aerial and earth respectively. The two lower terminals are for the telephones, while those on the right are normally not used. They are, however, connected across the detector, so that if the user desires to try some other form of crystal detector, he can readily do so by connecting it to the two terminals, having first lifted off the wire from the galena crystal. Further, if at a later date, as will probably happen, the user desires to try a valve detector with this tuner, it is only necessary to lift off the wire contact from the crystal, remove the telephones and short circuit the terminals

with a piece of wire. The tuner will then give excellent results with a valve.

The purpose of the plug socket is for the attachment of a 300-turn standard plug-in coil. To use this is merely necessary to place the "ten's" switch on the lowest terminal and plug in the coil when the set is immediately ready to receive the 2,600 metre time signals from the Eiffel Tower.

The manipulation of this tuner is very simple. To tune for broadcasting it is merely necessary to place the "units" switch on about its middle position and move the "ten's" switch until music is heard. Next adjust the "units" switch until best signals are heard, and if necessary make a final adjustment of the detector. This receiver will be found to give excellent results on a range of waves from about 200 or

800 metres without the external coil, and for those who do not immediately desire to receive the time signals the purchase of the coil can be delayed.

Instead of the plug socket, two terminals can be fitted and wired in the same way, whereupon any external loading coil can be added as desired.

APPENDIX A

LIST OF SPARK TRANSMISSIONS LIKELY TO BE HEARD ON A CRYSTAL RECEIVER, USING THE MAXIMUM AERIAL ALLOWED BY THE POSTMASTER-GENERAL'S PERMIT.

NOTE.—It should be possible with suitable tuners to hear all the transmissions listed below, but many can be heard only when conditions are particularly favourable. Some of the more distant stations will only be heard after dark. In compiling the list (which is based on the Regular Transmissions Sheet issued by the *Wireless World*), certain transmissions have been included which take place after sunset in the winter months, but during daylight in the summer. The wave-lengths of many of these stations are outside the range of purely "broadcast" receivers.

G.M.T.	Station and Call Sign.	Wave-length.	Remarks.
A.M.			
2.10	Warsaw WAR.	2,500	Meteorological report.
2.20	Paris FL	2,600	"
6.55	Sofia FF	3,500	"
7.15	Borkum KBM	1,250	"
7.20	Wilhelmshaven FUL	1,250	"
7.25	Swinemunde KAW	1,000	"
7.40	Reval ELN	2,000	"
8.15	Paris FL	2,600	"
8.20	Paris FL	2,600	"
9.25	Paris FL	2,600	Time signals (International).
10.0	Paris FL	2,600	Time signals (Beats).
10.35	Paris FL	2,600	Times for previous signals.
10.35	Paris FL	2,600	Special signals.
10.38	Paris FL	2,600	Times for previous signals.
10.44	Paris FL	2,600	Time signals (old system).
11.15	Scheveningen PCH	1,800	Meteorological report.
11.30	Paris FL	2,600	"

G.M.T.	Station and Call Sign.	Wave-length.	Remarks.
A.M.			
11.55	Nauen POZ . . .	3,900	Time signals.
12.0	Nauen POZ . . .	3,900	Time signals. (International).
P.M.			
12.05	Paris FL . . .	3,200	Press in French.
5.00	Sofia FF . . .	2,800	
5.00	Cadiz EAC . . .	2,500	Press in Spanish.
6.15	Borkum KBM . . .	1,250	Meteorological report.
6.20	Wilhelmshaven FUL	1,250	
6.25	Swinemunde KAW .	1,000	„
7.10	Warsaw WAR . . .	2,500	„
7.20	Paris FL . . .	2,600	„
7.40	Vossegat BE . . .	1,000	„
7.45	Warsaw WAR . . .	2,100	Press.
8.00	Karlsborg SAJ . . .	2,500	Swedish Press.
8.00	Madrid EGC . . .	1,600	Inland working.
8.30	Pola IQZ . . .	3,200	Navigation warnings.
8.30	Madrid EGC . . .	2,000	Meteorological report.
9.30	Norddeich KAV . .	600	„
9.30	Budapest HB . . .	3,100	Press in French.
9.45	Swinemunde KAW .	600	Meteorological report.
10.00	Paris FL . . .	2,600	Time signals (beats).
10.35	Paris FL . . .	2,600	Times for previous signals.
10.45	Paris FL . . .	2,600	Time signals (old system).
11.55	Nauen POZ . . .	3,900	Time signals.

THE UNDERMENTIONED COAST STATIONS ARE WORKING THROUGHOUT THE DAY AND NIGHT, AND SHOULD BE HEARD IN MOST PARTS OF ENGLAND. THEY WILL BE HEARD MUCH LOUDER AFTER SUNSET.

North Foreland GNF, Niton GNI, Land's End GLD, Fishguard GRL, Liverpool GLV, Cullercoats GCC, Ushant FFU, Cherbourg FUC, Boulogne FFB, Ostend OST, Scheveningen PCH, Havre FFH, Dunkerque FUD, Norddeich KAV. On rare occasions one or two of the Mediterranean stations may be heard. British Admiralty coast stations, such as Sheerness BYK, are also working from time to time. Numerous ship stations will be heard on 600 metres, and occasionally on 450 and 300 metres. Particulars of telephonic transmissions likely to be heard are given in Chap. VII.

APPENDIX B

THE MORSE CODE

ALPHABET.

a - - -	j - - - - -	s - - - -
b - - - - -	k - - - -	t - - -
c - - - - -	l - - - - -	u - - - -
ch - - - - -	m - - - -	v - - - - -
d - - - -	n - - - -	w - - - - -
e - - -	o - - - - -	x - - - - -
f - - - - -	p - - - - -	y - - - - -
g - - - -	q - - - - -	z - - - - -
h - - - - -	r - - - - -	é - - - - -
i - - - -		

FIGURES.

1 - - - - -	5 - - - - -	8 - - - - -
2 - - - - -	6 - - - - -	9 - - - - -
3 - - - - -	7 - - - - -	0 - - - - -
4 - - - - -		

PUNCTUATION AND OTHER SIGNS.

Full Stop (.) - - - - -	Error - - - - -
Note of Interrogation, or request for repetition (?) } - - - - -	End of transmission - - - - -
Note of Exclamation (!) } - - - - -	Invitation to transmit - - - - -
Hyphen or dash (-) - - - - -	Wait - - - - -
Bar indicating fraction (/) } - - - - -	Received Signal - - - - -
Call (Preliminary) - - - - -	End of Work - - - - -
Double dash (separating preamble from address, address from text, and text from signature) } - - - - -	All Stations - - - - -
	"TR" (prefix for preliminary correspondence) } - - - - -

APPENDIX C

LIST OF ABBREVIATIONS USED IN RADIOTELEGRAPH TRANSMISSIONS.

Abbrevia- tion.	Question.	Answer or Advice.
1.	2.	3.
----- (CQ)		Inquiry signal employed by a station which desires to correspond.
----(TR)		Signal announcing the sending of indications concerning a ship station (Article XXVIII.).
----- (!)		Signal indicating that a station is about to send with high power.
PRB	Do you wish to communicate with my station by means of the International Signal Code ?	I wish to communicate with your station by means of International Signal Code.
QRA	What is the name of your station ?	This station is . . .
QRB	How far are you from my station ?	The distance between our station is . . . nautical miles.
QRC	What are your true bearings ?	My true bearings are . . . degrees.
QRD	Where are you bound ?	I am bound for . . .
QRF	Where are you coming from ?	I am coming from . . .
QRG	To what company or line of navigation do you belong ?	I belong to . . .
QRH	What is your wave-length ?	My wave-length is . . . metres.
QRJ	How many words have you to transmit ?	I have . . . words to transmit.
QRK	How are you receiving ?	I am receiving well.
QRL	Are you receiving badly ? Shall I transmit 20 times ----- so that you can adjust your apparatus ?	I am receiving badly. Transmit 20 times ----- so that I can adjust apparatus.
QRM	Are you disturbed ?	I am disturbed.
QRN	Are the atmospherics very strong ?	The atmospherics are very strong.
QRO	Shall I increase my power ?	Increase your power.
QRP	Shall I decrease my power ?	Decrease your power.
QRQ	Shall I transmit faster ?	Transmit faster.
QRS	Shall I transmit more slowly ?	Transmit more slowly.
QRT	Shall I stop transmitting ?	Stop transmitting. I have nothing to transmit.
QRU	—	I have nothing for you.
QRV	Are you ready ?	I am ready. All is in order.
QRW	Are you busy ?	I am busy with another station (or with . . . please do not interrupt).
QRX	Shall I wait ?	Wait. I will call you at . . . o'clock (or when I want you).
QRY	What is my turn ?	Your turn is No. . . .
QRZ	Are my signals weak ?	Your signals are weak.
QSA	Are my signals strong ?	Your signals are strong.
QSB	Is my tone bad ?	The tone is bad.
	Is my spark bad ?	The spark is bad.
QSC	Is the spacing bad ?	The spacing is bad.
QSD	Let us compare watches. My time is . . . What is your time ?	The time is . . .
QSF	Are the radiotelegrams to be transmitted alternately or in series ?	Transmission will be in alternate order.
QSG	—	Transmission will be in series of five radiotelegrams.
QSH	—	Transmission will be in series of ten radiotelegrams.

Abbreviation.	Question.	Answer or Advice.
1.	2.	3.
QSI	What is the charge to collect for . . . ?	The charge to collect is . . .
QSK	Is the last radiotelegram cancelled ?	The last radiotelegram is cancelled.
QSL	Have you got the receipt ?	Please give a receipt.
QSM	What is your true course ?	My true course is . . . degrees.
QSN	Are you communicating with land ?	I am not communicating with land.
QSO	Are you in communication with another station (or with . . .) ?	I am in communication with . . . (through the medium of . . .).
QSP	Shall I signal to . . . that you are calling him ?	Inform . . . that I am calling him.
QSQ	Am I being called by . . . ?	You are being called by . . .
QSR	Will you dispatch the radiotelegram ?	I will forward the radiotelegram.
QST	Have you received a general call ?	General call to all stations.
QSU	Please call me when you have finished (or at . . . o'clock).	I will call you when I have finished.
QSV	Is public correspondence engaged ?	Public correspondence is engaged. Please do not interrupt.
QSW	Must I increase the frequency of my spark ?	Increase the frequency of your spark.
QSX	Must I diminish the frequency of my spark ?	Diminish the frequency of your spark.
QSY	Shall I transmit with a wave-length of . . . metres ?	Let us transfer to the wave-length of . . . metres.
QSZ	Transmit each word twice. I have difficulty in receiving your signals.
QTA	Transmit each radiotelegram twice. I have difficulty in receiving your signals, or Repeat the radiotelegram you have just sent. Reception doubtful.
QTB	Number of words not agreed ; I will repeat first letter of each word and first figure of each group.
QTC	Have you anything to transmit ?	I have something to transmit. I have one (or several) radiotelegrams for . . .

When an abbreviation is followed by a mark of interrogation it applies to the question indicated in respect of that abbreviation.

In addition to these signals, which, it will be observed, are uniform in construction, the following signals of the International Telegraph Code may be used in these communications :—

- - - - - "Repeat" sign (as well as mark of interrogation),
 - - - - - Understood.
 - - - - - Wait.

EXAMPLES.

Station.		
A	QRA ?	What is the name of your station ?
B	QRA Campania	This is the Campania.
A	QRG ?	To what company or line of navigation do you belong ?
B	QRG Cunard. QRZ	I belong to the Cunard Line. Your signals are weak.
Station A then increases the power of its transmitter and sends :—		
A	QRK ?	How are you receiving ?
B	QRK	I am receiving well.
	QRB 80	The distance between our stations is 80 nautical miles.
	QRC 62	My true bearings are 62 degrees, etc.

INDEX

	PAGE		PAGE
ABBREVIATIONS ...	73, 74	INDUCTANCE ...	8, 18
Adjustment of Crystals 53	<i>et seq.</i>	Iron pyrites ...	15, 55
Aerials, construction of 48	<i>et seq.</i>	JAMMING ...	9
Aerial insulators ...	49, 50	LOUD speakers ...	58
Aerials, natural frequency of 73, 74		MOLYBDENITE ...	15
"Ball and socket" detectors 40		Morse code ...	72
Bornite ...	15, 55	NATURAL frequency of aerial 8	
Buzzers ...	54	PERMANITE ...	15
CAPACITY ...	8, 19	Perikon... ..	15
Carborundum, properties of 11,	15, 55	Perikon, characteristic curve	16
Carborundum, adjustment of 16,	55	of	13, 14
Carborundum, character curve 12		Potentiometers ...	15, 55
Cerussite ...	15	Pyrites, iron ...	15, 55
Cerussite, character curve ...	17	Pyrites, copper ...	15, 55
Circuit for series crystal ...	20	RADIOCITE ...	15
Circuit for single-slider ...	21	Rectifiers ...	10
Circuit for two-slider ...	26	Resonance, principle of ...	8
Circuit for three-slider 28,	29	Resonance in tuners... 18	<i>et seq.</i>
Circuit for fixed inductance		SHIP station signals... ..	71
and variable condenser ...	29	Silicon	15, 55
Circuit for two-sliders and		Sliders	19, 21, 22
condenser ...	30	Stud switches... ..	22, 24
Circuit for variometer ...	30	Spark transmitters ...	70, 71
Circuit for stud switches ...	24	TELEPHONE receivers... 9,	45 <i>et seq.</i>
Circuit for loose couplers 35,	36	Telephone transformers ...	46
Chalcopyrites... ..	15, 55	Telephone transmissionsaudi-	
Condensers ...	19, 30	ble on crystal set ... 51	<i>et seq.</i>
Condensers, fixed ...	20, 60	Tuners, single-slider ...	23
Conventional signs ...	18	Tuners, two-slider ...	27
Copper pyrites ...	15, 55	Tuners, three-slider... ..	28
Croydon telephony ...	52	Tuners, with stud switches... 24	
Crystal receiver, how to build		Tuners with condenser ...	29
58 <i>et seq.</i>		Tuners with honeycomb, etc.,	
DETECTORS, "ball and socket" 40		coils	38
Detectors, carborundum ...	40	Tuning coils	19 <i>et seq.</i>
Detectors, cartridge... ..	43	Tuning and resonance ...	8
Detectors, with wire point... 40		VERNIER adjustment ...	25
EARTH connection ...	49	Valve added to crystal 56	<i>et seq.</i>
Eiffel Tower ...	52	WAVE-length and frequency 8	
FREAK circuits ...	39	Wood's metal... ..	15
Frequency and wave-length... 8		ZINCITE	15, 55
GALENA ...	15, 55		
HAGUE concerts ...	52		
Hertzite ...	15, 55		

AUCKLAND'S

of 395, ST. JOHN STREET, LONDON,

are Actual Manufacturers
of all APPARATUS for

Radio Telephony & Telegraphy

We can supply COMPLETE SETS for
HOME or EDUCATIONAL USE, either
SIMPLE CRYSTAL or MULTI-VALVE
RECEIVERS.

We can also supply from Stock, a
RANGE of ABOUT 500 COMPONENT
PARTS, for the ASSEMBLY OF YOUR
OWN SET.

*Send now for Catalogue No. 4, for comprehensive Details
of Apparatus.*

To "AUCKLAND'S,"

395, ST. JOHN STREET, LONDON, E.C.

Dear Sirs,

Please inform me without obligation, of Types
and Specification of a Complete Set for an outlay
of £ : : .

Also please send Catalogue.

Name

Address

THE BEST IS THE CHEAPEST

For Telephony, Spark and Paris Time Signals.

£4 10s. 0d.

complete
as illustrated.
Post 2s.

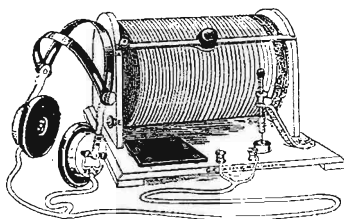

£4 10s. 0d.

complete
as illustrated.
Post 2s.

Single Valve Panels, £2 5s. 0d.

Amplifying Panels for use with valve or crystal sets, £3 10s. 0d.

Condensers, Basket Coils, Insulators, Wire, Enamel & D.C.C. Phones, &c.

Everything to make your own set. Stamp for List.

G. C. AIMER, X-Ray Tube Manufacturer,
31-32, Mortimer Market, Tottenham Court Road, W.C.1.

READ

The Wireless World AND Radio Review

Price 6d. Weekly.

Post Free 7d.

BIGGEST AND OLDEST RADIO JOURNAL.

It tells you How to Make and Use Your Set, and in addition to the Constructional and Instructional Articles, every issue contains specialised contributions of importance and value to experimenting amateurs. Readers' Questions answered by Experts Free of Charge through the pages of the "W. W. & R. R."

The WIRELESS PRESS, Ltd., (Dept. C.R.)
12-13, HENRIETTA STREET, LONDON, W.C. 2.

PUBLICATIONS OF
THE WIRELESS PRESS, LTD.

12 & 13, HENRIETTA STREET,
STRAND, LONDON, W.C. 2.

THE A.B.C. OF WIRELESS.

By PERCY W. HARRIS. This wonderful little book has been specially prepared for those who are desirous of getting a good outline of wireless without delving into textbooks. 64 pages. Price 6d. net, or post free 8d.

MORSE MADE EASY.

By A. L. RYE. A linen back card folded to fit the pocket. A speedy method of learning the Morse code. Price 3d. net, or post free 3½d.

THE CONSTRUCTION OF AMATEUR VALVE STATIONS.

By ALAN L. M. DOUGLAS. This book tells the reader how he may construct for himself apparatus which he desires to make, but does not know how to design correctly. 78 pages. 55 diagrams and illustrations. Price 1 6, or post free 1 8.

THE RADIO EXPERIMENTER'S HANDBOOK.

By PHILIP R. COURSEY, B.Sc. (Eng.), A.M.I.E.E., etc. A reliable guide to experimenters in wireless telegraphy and telephony. 113 pages. 99 diagrams and illustrations. Price 3 6 net, or post free 4/-.

MAGNETISM AND ELECTRICITY FOR HOME STUDY.

By H. E. PENROSE. Contains a course of fifty lessons particularly useful to the home student without previous knowledge. 515 pages. Price 6/- net, or post free 6 6.

THE ELEMENTARY PRINCIPLES OF WIRELESS TELEGRAPHY.

By R. D. BANGAY. In two parts. Price 4/- each. (Postage 5d.) Or in one volume price 7 6 net. (Postage 9d.) Invaluable for the student. Used by H.M. Government for instructional purposes.

THE WIRELESS TELEPHONE: WHAT IT IS, AND HOW IT WORKS.

By PHILIP R. COURSEY, B.Sc. (Eng.), F.Inst.P. 128 pages. Price 2 6 net, or post free 2 9.

**WRITE FOR OUR COMPLETE CATALOGUE OF
OVER 50 BOOKS.**

