

# WIRELESS WORLD

MONTHLY 3<sup>D</sup>

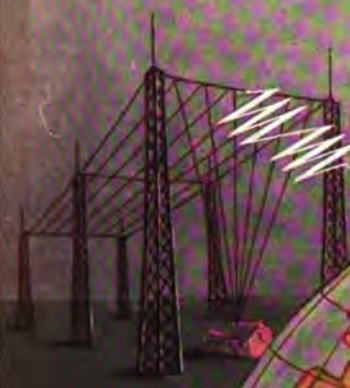
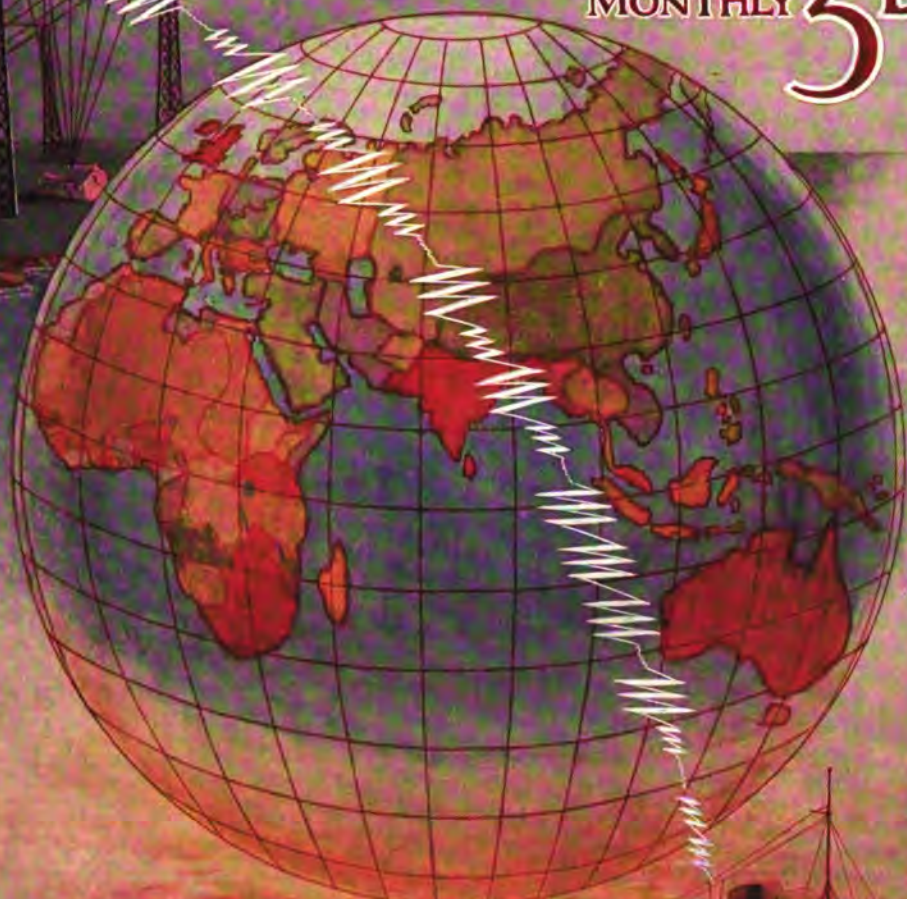

# SULLIVAN INSTRUMENTS

Sullivan "Universal" Galvanometers and Shunts for Land and Sea Use.

SULLIVAN TELEPHONE RECEIVERS.

Fast Speed Wheatstone Automatic Transmitters and Receivers, guaranteed at 400 words per minute, and Wheatstone Apparatus generally. Precision and Standard Measuring Equipments for D.C. and A.C. (high frequency) determinations, Condensers of Low Power Factor, etc.

**H. W. SULLIVAN** WINCHESTER HOUSE, LONDON, E.C., ENGLAND.  
Works: LIVERPOOL HOUSE, MIDDLESEX ST., LONDON, E.C.

Telegrams: "Deadbeat, London."

Telephone: Office: 3518 London Wall.  
Works: 3518a " "

Silk and Cotton Covered H.C. Copper Wire, Resistance Wires, Fuse Wire, Binding Wires, Charcoal Iron Core Wire, Asbestos Covered Wire

**P. ORMISTON & SONS, 79 CLERKENWELL ROAD**  
LONDON, E.C.  
Established 1793. 13259 Central.  
"Ormiston, London" Braided and Twisted Wires, Bare Copper Strand & Flexibles of any Construction, Wire Ropes & Cords, down to the finest sizes, in Galvanized Steel, Phosphor Bronze, etc.

# NORMAN, SMEE & DODWELL

MANUFACTURERS OF HIGH-CLASS VARNISHES for Coach Builders and Decorators, Railway Carriage and Locomotive Builders, and Ship Builders. Special Insulating Varnishes for Electrical Purposes

Offices and Factory: MILES LANE, MITCHAM, SURREY.

# WILLCOX'S

## Undertake Supply of all Requisites

### for Engine Rooms, Power Plant, Machine Shops, etc.

We shall be pleased to supply Electrical and other Engineers with copy of our enlarged

**736 pp. CATALOGUE**

on receipt of application on business form.

*Our Specially Refined Lubricants are in use on every class of Machinery.*



SEND  
US  
YOUR  
INQUIRIES

**W. H. WILLCOX & CO., LTD.**  
32/8 SOUTHWARK STREET, LONDON, S.E.

Please mention "The Wireless World" when writing to Advertisers.



Vol. 3.—No. 27. (New Series)

June, 1915.

Subscription 5/0 per annum  
post free. Price 3d.  
Post Free 5d.

## PRO-PATRIA

**I**N our March issue, under the heading of "A Word in Season," we exhorted amateur wireless enthusiasts to do their duty towards their Mother Country by ungrudgingly conforming to both letter and spirit of the Defence of the Realm Act. It is a common maxim among lawyers that "Hard Cases make Bad Law," and although each individual may feel in his own instance that there is no danger to the Commonwealth in his possession of wireless apparatus—it is nevertheless true that refusal to obey loyally and willingly hampers the Authorities responsible for the working of the Act. On the one hand they are obliged in the execution of their public duty to see that the Act is rigidly enforced, whilst, on the other hand, they are naturally reluctant to inflict heavy penalties upon people innocent of evil intent.

We take this opportunity of informing our readers that we have recently received an official request to endeavour once again to bring this home to those concerned. Since we wrote in March last the Regulations made under the Act have been amended and "tightened up" by an Order in Council. Not only, under the amended provisions, is every person forbidden "without the written permission of the Postmaster-General to buy, sell, or have in his possession, or under his control, any apparatus for the sending or receiving of messages by wireless telegraphy, or any apparatus intended to be used as a component part of such apparatus"; but no person is permitted to *make*, without official permission, any such apparatus, or its component parts.

It will, therefore, be seen that the Authorities are armed with full powers, and it is in the interests of individuals themselves to obey implicitly. We have, however, consistently refused to base our appeal to our readers on the grounds of *self interest*. Britishers can show themselves at a time of national crisis as patriotic as Germans, and it is with full reliance on this spirit that we make our appeal.

It has been suggested to us by the Authorities themselves that amateurs might take advantage of the cessation of practical experiments to increase their grasp of the theoretical side of the science. Many of the practical questions which have been asked us indicate most clearly that the questioners have not paid sufficient attention to the main principles underlying the practical applications concerning which they are making enquiries. Our pages will continue to be filled with matter of incalculable value in this direction to both amateur and professional students.

Our issue of December, 1914, emphasised the point that "even experts can always afford to be learning," and we would once again refer to the excellent opportunity for quiet reading and study afforded by the removal of all possibilities of doing practical work.

No more profitable experiment can at this juncture be made by an amateur than one involving his capacity for answering questions. Such publications as the series of test cards issued by the Wireless Press, Ltd., afford an excellent opportunity for this procedure, and we shall be pleased to answer any questions put by correspondents in cases of doubt or difficulty.



**DR. W. H. ECCLES,**  
**D.S.G., A.R.C.S., M.I.E.E.**

# Personalities in the Wireless World

DR. W. H. ECCLES, D.Sc., A.R.C.S., M.I.E.E.

**D**R. ECCLES was born in North Lancashire in 1875. His early education was mainly obtained at a private school where the hard-work habit was inculcated, but partly also at a secondary school where an inspiring teacher raised an appetite for science. Between school and college his studies suffered from diffusiveness, ranging from the steam engine to anatomy; but the part of this period that ultimately proved to be the most valuable was that spent in his father's workshops and office preparing designs and estimates for structural steel-work. In 1894 he entered the Royal College of Science. During three years at South Kensington he spent most of his energies in the Mechanical and Physical Departments, and in 1897 became a demonstrator there. In 1899, after some experience on the staff of an engineering journal, he joined the Wireless Telegraph and Signal Company, and the greater part of 1900 was spent at the Chelmsford works.

On leaving Marconi's, and after a period as assistant editor of an electrical engineering journal, Dr. Eccles obtained a post in the Department of Electrical Engineering at the South-Western Polytechnic, Chelsea. In 1901 a Mathematics and Physics Department was created in the Institute and he was made Head. Several strenuous years followed in consequence of the rapid growth of the new department. In 1911 he was appointed to the University Readership in Graphics at University College, London.

Dr. Eccles's researches in wireless telegraphy began at Chelmsford, where most of his spare time was spent on the theory of oscillation transformers, and some experiments on filings coherers were carried out for the Company. Since this first contact with wireless he has published upwards of thirty Papers on the science of wireless telegraphy, and numerous technical articles and essays dealing with every section of the subject. A short summary of some of this work may be of interest.

In 1906 there appeared an experimental Paper that did something towards unravelling

the action of the magnetic detector; then came experimental work and a theory of the electrolytic detector. In 1909 a rather revolutionary mathematical theory of the single point coherer was developed and supported by experiments. The theory led to the very remarkable conclusion that the coherer can be arranged to generate oscillations in a short circuit possessing capacity and inductance by passing a steady current through it. This was experimentally confirmed, and led to the very general theorem that under certain conditions a rectifying detector could become a generator of oscillations, and conversely a generator of oscillations could be used as a rectifier. The theory of the crystal detectors came later, and their asymmetrical conductivity was traced, not to the ordinary Peltier effect, but to the more obscure property known as the Thomson effect.

In 1911 he arrived at the mathematical result that the electric waves can travel faster in ionised air than in un-ionised air, and this led to a series of speculations that help to explain many of the most striking differences of day and night transmission. Heaviside has suggested that a conducting reflecting layer might exist in the upper atmosphere and be responsible for the propagation of signals far round the globe; the theory advanced by Dr. Eccles showed how a relatively slight ionisation of the upper air, involving a much smaller conductivity than had previously been thought necessary, might do what was required by a sort of "whispering gallery" mode of propagation. It suggested, moreover, plausible explanations of freaks, of the twilight effects, of long-distance daylight transmission, and of the changes sometimes produced in signal strength by slight changes in wave-length. Some of these speculations were supported by his observations during the partial eclipse of 1912.

Dr. Eccles is secretary of the Physical Society of London and secretary of the British Association Committee for Radio-telegraphic Investigations.

# Proposed Work to be Undertaken by the International Commission on Wireless Telegraphy\*

By W. DUDELL.

AT the first meeting of the Commission, which was held at Brussels on October 13th, 1913, a provisional plan was drawn up to investigate the following points—viz.: (1) A determination of the best method of assuring a constant emission, and of controlling this constancy; (2) relative measurements of the variation of the signals at different receiving stations from day to day as well as the variations due to a change in the wave-length or to any other characteristic feature of the radiation from the transmitting station; (3) a comparison of the strength of the signals received in different directions and at different distances from the sending station; (4) simultaneous measurements of atmospheric disturbances at different stations. It was also proposed to establish one or two control stations near the sending station, so that the question of atmospheric absorption might not affect the results. There are, therefore, three places where measurements have to be made—viz., at the emitting station, at the control station, where strong signals will be received, and at different stations spread out over the surface of the globe, where the signals will be very weak. It is proposed to deal briefly with the methods and apparatus suitable for the purpose in view with the object of initiating a discussion of the subject.

At the sending station it is necessary first to measure the antenna current, which will require ammeters suitable for high frequencies and strong currents up to 150 ampères at least. All ammeters of this class are of the thermic type, the heated conductor being such that its resistance is sensibly the same

for currents of high frequency as for those of direct current. In my opinion the best instrument is that of Hartmann & Braun. The current passes through a wire kept in a state of tension. Any lengthening of the wire, due to heating, produces a bending at the centre, and this movement is registered by a needle through suitable mechanism. With heavy currents several wires are used in parallel. The following apparatus, which is somewhat similar in idea, may be of interest. It consists of two copper tubes; on each tube a series of notches are made. A thin wire passes in zigzag fashion from

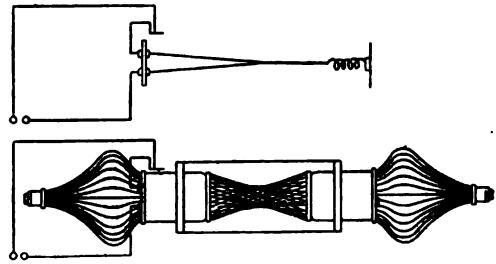

Fig. 1.—Device for measuring current in antenna.

one notch to another, as shown in Fig. 1, so as to form a kind of squirrel cage. The two tubular electrodes are given a rotatory movement with regard to one another, causing the wires to fall on the surface of a hyperboloid of revolution. Two wires are stretched along the axis of the hyperboloid and joined together in such a way that the weld (giving a thermocouple) is at the central part of the narrowing or contraction. These wires are taken to a millivoltmeter.

\* Translated from the official French publication.

With an instrument of this kind an E.M.F. of 5 millivolts is obtained when a current of 150 ampères passes. In order to obtain results quickly and satisfactorily it is necessary to place the cold junction of the thermo-electric couple in the neighbourhood of one of the tubular electrodes. The details have not been worked out, but the idea looks hopeful. Ammeters, which work on the principle of shunting a part of the current, give rise to serious errors on high

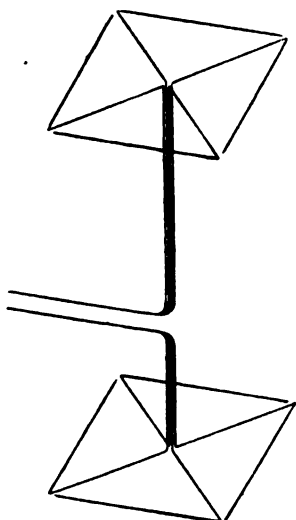

Fig. 2.—Lodge's type of antenna.

frequencies, if one starts with the assumption that the current behaves like a direct current. The ratio of shunting has been arranged in some instruments so as to depend on the ratio of the self-inductions and capacities of the circuits. If a condenser is placed in series with an ammeter for weak currents, and if the whole is shunted by a large condenser, the current passing through the shunt can be easily determined by the ratio of the condensers; if the instrument is only to be used for currents of high frequency, this method ought to give good results.

At the sending station it is also necessary to measure the damping of the antenna, which is usually done by Bjerknes's method. The antenna is used as a wave-meter, and is coupled to a measuring instrument so as to increase the damping as little as possible, while the antenna is excited from another

source of energy with a known decrement, or, better still, by means of continuous oscillations. It is uncertain what importance ought to be attached to the value found by this method. It is supposed that the train of waves decreases according to a logarithmic law—that is to say, that the damping in this circuit is perfectly constant and independent of the amplitude of the current that passes. It is doubtful if this result can be obtained in practice, and the value of the damping of the antenna is, therefore, of doubtful importance. The apparent resistance of the antenna is generally calculated from the observed decrement. This implies that the self-induction of the antenna is known as well as that of the circuit to which it is connected. Another method is to place in circuit with the antenna a non-inductive resistance, and to note the change of current produced, from which we calculate the apparent resistance. The interpretation of the results seems clear and definite if a high-frequency alternator is used to excite the aerial. It would, therefore, appear desirable to install at Brussels a small high-frequency alternator. The radiation resistance can be defined as the resistance which, when multiplied by the mean square of the value of the current, gives the amount of energy radiated into space. It is very difficult to determine this. The usual method is to note the effect produced by a change in the aerial. The spark frequency is easily found from the speed of the generator or by Prof. Fleming's method.

The nature of the antenna to be used at the control station requires very careful consideration, in order that changes, for instance, in the earth may not affect the accuracy of the results. Probably Lodge's type, as shown in Fig. 2, is best. On the other hand, it might be well to see whether a receiver with closed circuit, such as has been described by F. Braun, might not be better; amongst its other advantages might be mentioned the fact that the properties of the circuit could be defined very exactly and kept constant. The wave-length then requires to be determined. This can be done by the ordinary method, using a wave-meter with a rather loose coupling. The wave-meter must be calibrated with great exactness. It is probably best to compare it with a standard instrument made in the National

Laboratory in each country. The damping and apparent resistance of the antenna are determined as before. If the damping of the receiving antenna and of the apparatus connected to it is known, the damping of the received waves can be determined by Bjerknæs's method; but this implies certain hypotheses concerning the form of the train of waves, which ought to be carefully examined if one wishes to be very exact. If the control stations are at a distance of a few miles, the intensity of the received current is certainly sufficient to allow exact measurements with a sensitive thermal instrument, connected directly to the aerial. If at the control station the currents are of sufficient intensity, it is well to use a measuring instrument with a short period; if available, so short that the individual sparks can be distinguished on the photographic record, so that it is possible to be certain of the constancy of their amplitude and of the regularity of the emission.

At the different receiving stations it is necessary to determine the strength of the signals that are received, partly with a view to comparing results from day to day, and partly to compare the results which are obtained at the different stations on the surface of the earth. There are two ways of doing this: (1) To adopt for antenna and for earth a distinct type, which can be used at each receiving station where absolute measurements are to be made; (2) to adopt a standard method for testing aërials and earthing arrangements, so as to obtain comparable results. This latter standardisation can probably be done by using a radiating circuit that is practically closed, from which one emits definite quantities of radiating energy at known distances from the different receiving antennæ. If we measure the current received in the different antennæ it is thus possible to determine their properties. In choosing a receiving aerial, four types can be taken into consideration. The straight conductor, the umbrella type, the form "T" or "L" with two masts, or Lodge's type with four masts. Each of these kinds of antenna can be connected either with the earth or with a capacity forming a balance. It is probable this latter plan is the more definite. For reasons of symmetry it is well to avoid the "T" or the "L" shape. Probably the

best thing is Lodge's antenna with a capacity forming a counterbalance well above the surface of the ground and similar in shape to the upper part of the antenna. Its properties are at any rate better defined. The question of a standard antenna is more difficult, because of the uncertain effects of surrounding trees, &c.

As to the means for measuring the strength of the signals received, this depends on the best type of receiving apparatus and on the methods of measurement. There are five principles on which a measuring instrument can be designed. It may be thermic, electrostatic or electrodynamic; or it may rectify the current, and be used to give results either orally or by means of a galvanometer, with or without a photographic recorder. The first three methods have been most usually employed up to the present. The method of rectifying the current is the most sensitive, but there is a considerable difficulty in standardising and in obtaining a constant rectification and also in interpreting the results. There are a number of crystals that are used for rectifying, and they work well. But their resistance is high, which makes difficulties in the construction of the galvanometer. But there appear no longer to be any serious difficulties in the construction of galvanometers with a short period of sufficient sensitiveness to give measurable elongations of the signals, provided they are sufficiently strong in the ordinary sense of the word. According to experiments made by the author, the high-resistance detector gives a current of  $5 \times 10^{-8}$  ampères and even more in the received signals, and there ought not to be any difficulty in obtaining a measurable elongation by means of a galvanometer with a period of a few tenths of a second with such a current. It is well to point out that from many points of view there is a considerable advantage in working with an instrument with a short period. One of the principal advantages is that an instrument with a long period follows very slowly, and consequently very short signals and atmospheric disturbances may become merged in some sort of way in a kind of general integration of the signal. The thermic and electrostatic methods are much easier to interpret, seeing that they do not necessitate the use of a detector, but, on the other hand, they are much less sensitive. With thermic instru-



ments the sensitiveness is such that if the resistance of the heated portion is small—say, less than 40 ohms—it is difficult to measure currents less than 20 or 30 micro-amperes, and the instruments in general take an appreciable time before they reach the maximum elongation. As for electrostatic detectors, the author has constructed one which consists of a band of gold leaf or of aluminium foil, attracted by a fixed plate, the whole being placed for examination on a table beneath the lens of a microscope; this gives a deflection of one division per volt of the eyepiece micrometer; the tenth of a division is easy to read, and it is possible to estimate even smaller fractions. Oral methods, such as that of the shunted telephone, do not appear to be suitable for giving exact results, after taking count of the difficulty of eliminating personal errors, and the Commission would do well not to employ this method except in cases where the signals are so weak that galvanometric methods cannot be employed. A method by which the strength of the signals is increased before attempting to measure them is deserving of further study. This amplification would naturally simplify matters. But the only type of apparatus which seems to promise success is the type using ionised gas, with regard to which nothing seems to be known as to the amount of the magnification—in other words, it is not known what ratio the current received bears to that furnished by the valve; neither is it known whether this ratio remains constant. The only information that is available seems to show that the matter depends on the voltage and the length of time the valve is in use. Much more, therefore, remains to be done before its use can be recommended. The method of measuring the signals is connected with the problem of the different connections that can be used between the measuring instruments and the receiving antenna. If the apparatus is to be as simple as possible, there are only two ways: either the measuring apparatus can be directly inserted in the aerial circuit, or the instrument can be put in a special circuit, which can be connected to the receiving antenna by magnetic or electrostatic coupling. This latter alternative may make it necessary to tune the two circuits of the

antenna and the receiving circuit, and it is possible that some coupled waves may be produced which will interfere with the standardisation.

The measurement of the damping of the received signals presents considerable difficulties unless the receiving instruments are extremely sensitive, or unless the signals are very well marked. The same principles would hold good as in the case of the control stations. But, considering the difficulties and uncertainties of the matter, it may well be deferred till a later stage. It is necessary to consider whether a photographic record of the signals is necessary or not. From many points of view it is doubtless an advantage. But, on the other hand, it leads to complication and expense. Some system of automatically recording the signals ought to be developed; probably a photographic recorder would work with signals which were received at a distance not exceeding 1,000 km. from the sending station. At greater distances the signals would probably be too weak for any kind of recorder of the automatic type. With reference to atmospheric disturbances, they should be automatically recorded at the same time as the signals are received; no special apparatus would then be necessary. It would probably be easy to adopt some form of registering apparatus suitable for short signals, such as those sent out by an ordinary Morse transmitter.

The author therefore proposes that the Commission should approve of the following course of action. The first point would be to see whether it is possible to standardise existing antennæ in such a way as to obtain comparable results, or whether, on the other hand, it is necessary to construct special antennæ for the purpose. It is thus of importance to have a standard method of measurement or an instrument, which need not be very sensitive, with which the others could be compared. We must also design and construct a closed or nearly closed radiating circuit, capable of radiating definite quantities of energy of different wavelengths. We must also have a closed or nearly closed receiving circuit, which can be used in connection with the standard measuring apparatus, so as to determine the radiation of the circuit.

# Digest of Wireless Literature

ABSTRACTS OF IMPORTANT ORIGINAL ARTICLES DEALING  
WITH WIRELESS TELEGRAPHY AND COMMUNICATIONS READ  
BEFORE SCIENTIFIC SOCIETIES.

## THE "KENOTRON" RECTIFIER.

In a recent issue of the *General Electric Review* Dr. Saul Dushman gives a description of a new form of rectifier for high-pressure electric currents, to which the name "Kenotron" has been given. The word "kenotron" is derived from the Greek adjective "kenos," meaning empty, and the suffix "tron," indicating an instrument or appliance. The instrument, which has been evolved in the General Electric Company's laboratory at Schenectady, in many points resembles Dr. Fleming's valve rectifier in being based upon the phenomena of emission of electrons from incandescent metals, but is used for much higher pressures. Dr. Fleming's valve, as our readers probably know, consists of a filament sealed in a glass bulb, a metal plate being placed close to the filament so as to leave very little space between the two. The bulb is exhausted of air and the filament is made to glow by means of an accumulator. To obtain the rectifying effect a source of potential is connected to the filament and the plate, the filament being made negative and the plate positive. The space between the filament and the plate then becomes possessed of unidirectional conductivity and is utilised in wireless receivers to rectify received oscillations.

In hot-cathode rectifiers it can be shown that the current from the hot cathode is due to convection of electrons (negatively charged corpuscles having a mass of about 1-1800th of that of a hydrogen atom) by deflecting the current in magnetic and electrostatic fields and determining the ratio  $e/n$ .

Dr. Irving Langmuir, who has done considerable work on the subject, has found that in the case of heated tungsten filaments the electron emission at constant temperature increases as the vacuum improves until a constant value is attained, which varies with the temperature in accordance with

an equation laid down by Richardson. In the types of hot-cathode rectifiers exhausted by ordinary methods, the electron emission is accompanied by a blue glow, and the cathode gradually disintegrates; it was found that the blue glow was due to the presence of positively charged gas molecules (ions) and that the disintegration of the cathode was due to bombardment by these ions. When the vacuum is made as perfect as possible, however, conduction occurs only by means of electrons emitted from the hot cathode and there is no blue glow.

By means of a special form of air-pump arrangement Dr. Dushman has succeeded in attaining a vacuum as high as  $5 \times 10^{-7}$  mm. of mercury. The thermionic current in a high vacuum depends directly upon the nature of the electrodes and the temperature, values for tungsten being as follows:—

Absolute temperature. Centigrade.	Milliamperes per cm. <sup>2</sup>
2000 ... ..	4.2
2200 ... ..	48.3
2400 ... ..	364.8
2600 ... ..	2044.0

There is, however, another factor influencing the electron current—namely, the electrostatic field or "space-charge," observed by Dr. Langmuir, which is set up by the electrons emitted from the hot cathode; the effect of this charge is that with a given voltage the current increases with temperature according to Richardson's equation only up to a certain temperature, after which it remains constant. The higher the voltage between the electrodes, the higher is the temperature at which the limit is reached, but in no case does the current at a given temperature exceed the value given by Richardson's equation, no matter what the voltage. As the absence of positive ions, and therefore of gas, is essential, the appropriateness of the name "kenotron" is obvious.

The current-carrying capacity of the kenotron, when given sufficiently high voltage between the electrodes, is limited only by the area of the surface emitting electrons and its temperature. It is necessary to limit the temperature to such a value that the life of the filament is at least 1,000 hours.

An important point in the design of the kenotron is the prevention of electrostatic strains on the filament due to the high voltage, the electrostatic attraction between the electrodes being proportional to the square of the voltage. During the rectifying phase the P.D. is very low, but during the other half cycle the electrodes are subject to the full P.D. of the line. Various symmetrical arrangements have been adopted, one of which is a molybdenum cylinder with a coaxial filament. For direct-current pressures up to 15,000 volts the diameter of the cylinder need not exceed  $\frac{1}{2}$  in., while the length may be up to 4 in., with a 10 mil. filament as cathode. For D.C. pressures up to 75,000 or 100,000 volts the diameter of the cylinder is increased to 5 cm. A tube intended to rectify 10 kilowatts at 100,000 volts, with a carrying capacity therefore of 100 milliamperes, has a loss of only 1.25 per cent.

Kenotrons have been constructed for D.C. voltages up to 100,000 volts, and currents up to 1.5 amperes; the author has every expectation of extending their application to 200,000 volts. It is preferable to construct them in the form of 10-kw. units when the voltage exceeds 25,000; for lower voltages smaller units are advisable. Unlike the mercury vapour rectifiers, they can be operated in parallel.

In the laboratory the kenotron facilitates the production of small direct currents at very high voltages, for spectroscopic work, etc., and for testing the dielectric strength of insulation. It is also well adapted for X-ray work. Many other uses will also suggest themselves to the reader. Certain experiments in wireless telegraphy would also be facilitated by its aid.

#### EXPERIMENTS WITH LOW HORIZONTAL AERIALS.

In a recent issue of the *Electrical World* Messrs. Charles A. Culver and John A. Riner describe a number of experiments they have performed with low horizontal aerials. In

addition to a telephone wire 250 metres in length and 3 metres high, referred to in a previous paper, there was established a second low horizontal system consisting of a single wire of approximately the same length and height, but extending in a south-easterly direction (instead of towards the south). On the night of November 17th, 1913, a heavy mist prevailed at Beloit, and all outdoor objects were thoroughly wet. Owing to poor insulation, the above line was grounded at one point at least, and probably at other points, but even under these unfavourable conditions signals from Atlantic coast and other stations were heard strongly when this line was used in place of the ordinary aerial.

At 7.26 on the evening of November 23rd the Arlington station was heard sending longitude signals to Paris, using either the telephone line or the special low horizontal antenna. The weather was fair and cool. Similarly Arlington and Key West were heard loudly at Beloit on the night of December 8th, the weather being clear and cold. At 11.45 p.m., January 28th, 1914, while rain was falling, a coast station was heard on the horizontal system as plainly as when employing the large aerial of the Beloit station. On the same date the experiment was tried of utilising the horizontal system as a "ground" in connection with the large aerial. This combination likewise gave strong signals.

As a result of the above preliminary tests with low antennas, and of those reported in previous papers, it was decided to carry out further experiments of a similar character over distances comparable to those occurring in radio-telegraphic practice. Accordingly a series of tests were conducted between Beloit, Wis., and a temporary field station at Freeport, Ill., the distance covered being approximately 34 miles (54.7 km.). The antenna of the Beloit College station is of the L type, and consists of a four-wire horizontal portion some 90 metres long, with a slanting two-wire section about 30 metres in length. The horizontal section makes an angle of 45 degrees with the meridian, the free end extending to the south-east. Energy is delivered to this system by a 1-kw. transformer operating through a rotary non-synchronous gap and loosely-coupled oscillation transformer. Signals of a fairly

constant intensity were automatically sent out by the Beloit station on a 900 metre wave-length, and received by the field station near the city of Freeport. The logarithmic decrement of the Beloit station when using the above wave is approximately 0.16.

The field station at Freeport employed the usual loosely-coupled receiving transformer with crystal detector and telephone receivers. As no facilities for quantitative measurements were available at the time, the tests about to be described were purely qualitative in character.

The first series of tests were made on July 10th, 1914, the receiving station being established in a field on a bluff about 60 feet above a creek. The receiving wire consisted of a poorly insulated cotton covered wire (No. 18 gauge) 274 metres in length, which in the course of the experiments became bared. One half of the wire was laid on the ground, and the other suspended from branches of trees, etc., at a height of some 7 feet above the ground. The receiving transformer was in this experiment placed in the centre. With this arrangement various signals were heard from Beloit on several days. On July 14th one-fourth of the wire which had previously been kept clear of the ground was lowered so as to rest on the grass, and it was found that signals were still readable. When three-fourths were placed on the ground signals were diminished in intensity, and when it was entirely on the ground no signals could be heard. When, however, the wire in question was shortened by 77 metres and the free end lying on the ground the loud signals which resulted seemed even stronger than when the original wire had been entirely supported.

After this various arrangements were tried, and the wire was placed completely on the ground. The most satisfactory results were obtained when the wire on the Beloit side of the receiver was 61 metres and the wire on the other side 138 metres. Space will not permit us to give fuller particulars of the many interesting experiments which were performed, but it may be stated that, although the wire was bare and lying in many instances on the wet grass, signals were quite easily received.

Having determined the most satisfactory method of receiving by means of a single wire

each side of the receiver, the authors next tried the effect of multiple wires, and found much better results to be obtainable by duplicating the wire on the side away from Beloit. By adding still a further wire on the side away from Beloit, making three in all, an additional improvement was obtained. The experimenters next tried the effect of increasing the number of wires on the side towards Beloit, and an improvement again made itself apparent. The result of adding a second wire to the part towards Beloit was most marked in several respects. In the first place the intensity of signals was greatly augmented; in fact, the intensity of certain signals appeared to be as great as when the large elevated aerial at Beloit was used. A third wire still further improved the reception, and signals from Sarnia (600 kilometres away) came in especially loud. An important point was now observed—namely, that the tuning was found to be as sharp as that which obtains when employing elevated aerials of the commercial types.

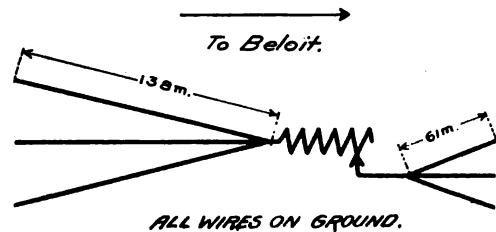

The best arrangement of wires is clearly shown in the accompanying diagram. The authors, in conclusion, state that the system would appear to operate most effectively when its electrical length, including the winding on the transformer primary, is something like one-fourth that of the incident wave. The receiving instruments, it seems, should be inserted about one-third the distance from the end nearest to the transmitting station, and to operate at the same efficiency the total length of such a ground-wire system should be approximately twice that of the elevated aerial. When used as an absorber, insulation of the wires apparently plays a very minor part. The ease and dispatch with which an earth-wire system may be installed make the plan a valuable one under certain conditions.



Juneau—The Capital of Alaska.

## Wireless Development in a Wilderness

By J. R. IRWIN.

**I**N the development of all new countries during the past half century the telegraph has always been one of the most important factors in the progress of the pioneer work. It is doing its full share in Alaska to-day.

Mr. J. J. Underwood, the famous journalist, author, and explorer, whose work on Alaska constitutes a reference and history of that vast territory, has most appropriately named his book—*Alaska: an Empire in the Making*. The sub-title is a statement of a fact. Although the country is old in discovery and early settlement, its "making" has been in progress but a few years—in fact, is contemporaneous with the progress of wireless telegraphy, which to-day is the most important and, at the same time, the most logical and efficient means of communication in the territory.

Alaska was discovered as early as 1728 by Vitus Bering, a Dane, holding a commission in the Russian Navy, but it was not until 1873 that the first settlement was established on Kodiak Island. Thereafter the progress of colonisation was very slow, and was confined principally to fur hunters, traders, and others of adventurous spirit.

In 1867 Alaska was sold by Russia to the United States for the sum of \$7,200,000. From that year up to December, 1914, incomplete statistics show that the exports of the territory during that period are in excess of \$500,000,000—a truly wonderful bargain. The trade for 1914 was exceptionally good, totalling more than \$72,000,000, with an estimated population of but 68,000, including Indians, Eskimos, and others.

The principal exports include gold, copper,

salmon, furs, and innumerable other commodities.

Besides producing gold and copper, Alaska seems destined to become an important factor in another industry—the manufacture of tinplate and steel. Throughout the territory there are immense beds of hematite and magnetite iron, and in the north-western section several tons of tin are produced each year. In the Matanuska coalfields a high-grade coking coal has been uncovered in immense quantities. Some day, perhaps in the near future, these three minerals will be brought together at one point and another big industrial centre established on the Pacific seaboard.

In addition to these minerals, Alaska produces silver, gypsum, marble, graphite, petroleum, mica, and lime. In metals and minerals prospectively valuable, but not being produced in commercial quantities, are tungsten, quicksilver, lead, arsenic, antimony, manganese, asbestos, bismuth, zinc, garnets, and jade.

That Alaska has tremendous agricultural possibilities is the opinion of many agricultural experts in the employ of the Government, who have conducted experimental stations in the territory for a period of

fifteen years past. Oats, wheat, barley, rye, and all kinds of root vegetables are successfully matured. Cereals grown in Alaska won the first prize against all comers in the United States at a land and irrigation exposition recently held in Minnesota.

The area of agricultural land in Alaska has been estimated at 100,000 square miles—more than the entire area of similar land in the Scandinavian Peninsula. It has been computed by experts that this area of land will support a population of 10,000,000 engaged in dairying, grazing, and agriculture.

When these various potential resources are developed—and that will be within a few years, for the Government has undertaken the construction of 1,000 miles of railroad in the country—Alaska will, indeed, be an important territory—a territory in the development of which the Marconi Wireless Telegraph Company hopes to play its part.

Alaska has a coast-line of 26,000 miles, and, including its islands, an area of 590,804 square miles, included in which can be found every known topographical and geographical formation yet discovered. It will, therefore, be readily understood what



*Trappers' Summer Quarters—Alaska.*

tremendous difficulties are encountered in the building of telegraph lines and in the laying of submarine cables.

In fact, so difficult is the problem that, with

States, the existing telegraph system of Alaska to-day consists of only a few hundred miles of telegraph lines operated by the Military Signal Corps, over which



*L. C. Smith Building—Seattle—Headquarters of Marconi Company in North-West.  
Highest Building outside New York.*

the exception of the Government cable connecting the territory with the United

the rates for the transmission of messages are the highest of any system in the world.

With the advent of successful wireless telegraphy came a change for the better in so far as communication with points hitherto unserved was concerned. The Government, through the Navy and War Departments, rapidly established stations at convenient points throughout Alaska, and gradually organised a system of wireless stations connecting with its various cable offices. But the same exorbitant rates still prevailed. During this same period private interests, quick to see the great convenience which Marconi had placed at their disposal, installed numerous equipments at their plants, thus enabling them to keep in touch with the outside world, which hitherto they had been compelled to do at very great expense and loss of time. Sometimes a message to the United States would take weeks to reach its destination, generally being conveyed by boat from the cannery, or mine, to the nearest Government cable or wireless station.

At the present time there are numerous privately owned stations leased from the Marconi Company, principal among them being Chignik, Naknek, Kodiak, Nushagak, Koggiung, and Clark's Point, all salmon canneries owned by the Packers' Association.

Other salmon packers prefer to equip their sailing vessels with Marconi apparatus. These ships yearly make the voyage north from United States Pacific ports to the canneries of Alaska, carrying with them the season's supplies and the cannery crews, coming back fully laden with the annual catch, and returning the crews to their southern homes. These vessels upon arrival at their respective plants in Alaska, anchor off the cannery which they serve, and for the remainder of the season are utilised as floating wireless stations, which keep their owners in the south advised of the success or non-success of the season's fishing. Prices can, therefore, be governed, and contracts for future sales be consummated long before the season's pack leaves the cannery. Previous to the advent of wireless in this field such information was unavailable until the return of the vessels to their home ports.

Not even after each ship has left its northern anchorage is the use of wireless completed. By means of the apparatus,



*Ketchikan—Operating House completed and Power House under construction.*

its progress towards home is despatched nightly to the waiting owner, who can estimate the approximate date of arrival and delivery of fish. Another great money saver which it provides is shown upon arrival off the entrance of the home port. In fog or any kind of weather tugs can be summoned by means of wireless to tow the laden vessel into port, whereas in pre-Marconi days a ship ran the chance of lying off shore for weeks, without means of attracting a tug to her assistance. In heavy weather these vessels sometimes would make the entrance, find no tug, and be compelled to beat off shore again until propitious conditions enabled her to lay-to off the entrance and wait the desired assistance.

In 1913 Alaska's development, and the crying public need for a better system of communication between the territory and the United States, decided the Marconi Company of America to extend its activities in Alaska, and to enter into competition with "Uncle Sam's" cable. To-day there are under construction moderate-powered stations at Ketchikan, the first port of entry into Alaska, and at Juneau, the territorial capital. These stations will communicate with a similar station at Astoria, Oregon, which is also under construction, and will be the United States terminal. Traffic to and from all parts of the United States and the world will connect at Astoria with the telegraph companies, while business destined for the city of Seattle, Washington, which is termed the "Gateway of Alaska," will be relayed by wireless direct to the 42nd Story "L. C. Smith" Building in that



city, where a modern station has been installed, and which also contains the Northern Division headquarters of the Marconi Company.

The photographs of the Ketchikan plant accompanying this article will illustrate some of the troubles experienced in carving a Marconi station out of a primeval forest, in a country where the rainfall is over 168 inches a year. At Juneau the difficulties are even greater, as the thermometer in winter descends below zero when the winds blow from the great Taku Glacier.

is also used as a transmitting antennæ for a five kilowatt equipment used for communicating with ships at sea. The towers stand at four corners of a rectangle, 300 feet by 600 feet, the long axis of which points directly towards Astoria, Oregon, where a duplicate of this station is being constructed. A twenty-wire antenna is supported between the towers, and all twenty wires are carried to the fireproof steel power-house, located approximately 300 feet from the first two towers, and exactly on the long axis of the rectangle mentioned above.



*Ketchikan Station.*

Ketchikan should be termed the hub of the system, as this station, occupying such a central location, will act as the relay point for the entire Alaskan scheme.

Most people are first attracted by the aerial-carrying structures of a radio station. The self-supporting steel towers at Ketchikan are four in number, and each one is 300 feet high; stepped on top of each tower is a wooden topmast projecting 14 feet above the head of the steel, on which are mounted 80,000 volt triple petticoat porcelain insulators carrying the receiving aerial, which

The ground system consists of some three thousand pounds of zinc plates buried in a circle about the steel-power house, and with three strips 4 feet wide running out on the beach to mean low-tide levels. One strip is placed in the bed of a small creek, and, owing to the excessive rainfall, all plates are continually wet.

Power is obtained from the city plant in Ketchikan, about 2 miles distant, at 2,300 volts, and a frequency of 60 cycles. At a point 300 feet from the power-house the current enters an underground conduit, and



*Astoria Station—North Towers.*

is taken to the high tension switchboard, and from there distributed to the wireless, lighting, and heating transformers, according to the usual standard methods.

In the steel and concrete power-house are located switchboards, rotary converter for furnishing direct current for the operation of the solenoid keys, side disc motors, remote control switches, and, in addition, the 25-kw. rotary disc is driven by the converter. All power transformers, the 25-kw. condenser bank of 30 tanks, oscillation transformer for the large set, and solenoid key are operated from the receiving house, 75 feet distant.

The receiving office is a wooden building, and contains a 5-kw. plant for corresponding with ships. In addition to the ship station, it contains all controls for the 25-kw. plant. The operator can, without moving from his chair, start and operate either the 5-kw. or 25-kw. plant.

The receiving apparatus consists of two tuners of the latest design—one with a range of 100 to 4,000 metres, and the other from 100 to 7,000 metres.

The living quarters for the staff contain all modern conveniences, and are comfortably

furnished by the company in its usual liberal manner.

A splendid water supply is obtained through a 4-inch pipe from a reservoir with a capacity of 12,000 gallons, located on high ground to the rear of the station. The water comes direct through virgin forests from the perpetually snow-clad mountains, but a few miles distant.

At Astoria, Oregon, an exact counterpart of the Ketchikan station is being constructed. There the work is less difficult, as the site is located within the bounds of civilisation.

At Juneau, the largest city in Alaska, there is under construction a 10-kw. station, which will communicate with Ketchikan. Only two 300-foot towers are being employed; in all other respects, however, the plant will be similar to those at Ketchikan and Astoria.

Juneau is the headquarters of the mining industry, and is growing with mushroom-like rapidity. From this city the bulk of the traffic will originate.

These three stations will form the nucleus of a system which will embrace the entire territory of Alaska, a system which will cause the name of Marconi to be added to the list of pioneers, explorers, and scientists whose efforts and work will have principally contributed to the development of what promises to be the newest State in the Union of the United States.



*Astoria Station—Two forward Towers under construction.*

# The ENGINEERS Note Book



[Under this heading we propose to publish each month communications from our readers dealing with general engineering matters of various kinds in their application to wireless telegraphy, and we would welcome criticisms, remarks and questions relating to the matter published under this heading. We do not hold ourselves responsible for the opinions and statements of our contributors.]

## The Mechanical and Physical Properties of some of the more common Solid Insulators.

**T**HE mechanical properties of insulating materials are of the greatest importance in the design of radio-telegraphic as well as ordinary electrical engineering apparatus.

In mechanical or civil engineering the machines, or other works, are largely built of one material entirely or of materials of similar natures, such as the metals; but in electrical work it is necessary to combine metals with parts made of materials with very different mechanical and physical properties, and the problem of making a sound construction, which will withstand the service expected from it, becomes more complex.

From the point of view of their mechanical properties, solid insulators (excluding paper, tape, india-rubber and similar flexible materials) may be divided into the following classes:

Vitreous bodies, such as glass, porcelain, and electrical earthenware, which can be moulded or cast into shapes.

Materials such as slate or marble, which usually occur naturally and can be cut to shape.

Ebonite and several compounds of similar nature which can be moulded or worked into shape.

A large variety of paper impregnated with varnishes or other compounds to form solid boards or tubes.

Mica and the materials made from it.

The above is not exhaustive as there are many materials, now on the market, which have properties similar to one or other of these classes, although manufactured from quite different substances.

The high voltages which are now used by a number of large electric power companies have led to great attention being paid to the manufacture of porcelain for electrical purposes, with the result that it is now possible to obtain insulators of every variety of shape in material of high dielectric strength.

Porcelain is chiefly used for transmission line insulators, and bushes passing for conductors through the walls of buildings or instruments. It is also used for formers, on which reactance coils may be built for enclosing them. The inferior varieties and earthenware are used for small electric fittings and for containers for oil-filled condensers.

These materials have the disadvantage that it is impossible to make the finished articles true to dimensions, and since no work can be carried out on the finished products, fitting them to the work in hand is not so neat a job as it otherwise would be. Thus a large clearance has to be allowed when a metal bar has to pass through a tube in porcelain since the walls are not quite parallel and straight, and, in bolting to metal, lead or rubber washers must be used

to take up inequalities of surface and distribute the pressure. This prevents the use of porcelain in many places where its resistance to distortion under heat and other properties would render it valuable.

Some kinds of porcelain are vitrified right through, but others have only a surface glaze. In the latter case the dielectric strength depends greatly on the surface being intact and free from cracks.

In some methods of manufacture the material is subjected to two firings. After the first it is known as "biscuit," and a certain amount of work such as grinding flat surfaces can be done, but even then there will be distortion after the second firing. Porcelain is used in places where it is subjected to pressure only as it is not suitable for withstanding tensile or shearing stresses. It is very suitable for use in exposed situations, such as insulators for wireless aeri-als and their mast stays.

Glass is not used to any large extent as an insulating material as distinguished from a dielectric.

In the latter capacity it is largely used for condensers for radiotelegraphic transmitting sets, for which its high dielectric strength and dielectric constant make it suitable.

As an insulator it is inferior to porcelain, since the surface of most kinds of glass is hygroscopic—that is, attracts moisture from the atmosphere by which the insulation is reduced even in fairly dry weather.

Ebonite is an insulating material which is very largely used in all kinds of electrical work. This is due to the fact that it possesses high dielectric strength and can be machined with almost the same facility as metals, although it wears the tools used to a greater extent. It can be obtained moulded to shape, and the moulded parts can be trued up to fit the job in hand. It can be tapped to take screw threads of all sizes, which will stand a fair amount of wear. Only threads of moderately large size can be cut in it.

It possesses the great disadvantage of becoming soft under a moderate temperature. For precision work the fact that it shrinks slightly under pressure and contracts with rise in temperature is apt to cause annoyance, and it cannot therefore be used in any standard instrument of which the dimensions must remain constant, such as

the spacing of the vanes of an air condenser. The insulation resistance is very high, but is reduced on prolonged exposure to light due to reduction of sulphur from the surface layers, a fact which has caused it to be replaced by other materials in the construction of certain standard apparatus.

Marble is a substance which possesses excellent mechanical properties for many electrical purposes, but unfortunately its electrical properties frequently debar its use. Nearly every specimen has metallic veins running through it, and due to these the insulation resistance is lowered. It is, therefore, not possible to use it for high voltage work or where high insulation resistance is required. Switchboards for low tension work are often made of marble. Slate has more constant electric properties than marble, and is largely used for switchboard work. It is usually enamelled, since this improves the appearance and also prevents the insulation being lowered by absorption of moisture in the pores of the material.

The dielectric strength is not so high as porcelain or ebonite and it is not, therefore, used for high-voltage work.

Mica is a mineral having electrical properties of high value, but the form in which it is found precludes its use for a large number of purposes.

Before it can be used the natural mineral has to be prepared by splitting into flakes so that the impurities which are embedded can be removed. The flakes are then graded as to size and quality.

Mica is not affected by moderate heat and will withstand pressure, but has a great tendency to split into thin flakes and is therefore not suitable in situations where it might be rubbed by adjacent parts. It is used for insulating between commutator bars and also as a dielectric for condensers, and is made up into micanite, which consists of flakes of mica stuck together by shellac or other cement. Micanite is more flexible than mica, but has not so high a dielectric strength.

There is a large number of manufactured materials now on the market for use as insulators for various purposes. A large number consists of paper, impregnated, generally under pressure, with various insulating varnishes or other compounds. As might

be expected, these vary greatly in their mechanical and electrical properties. They can be obtained as sheets or tubes, which can be worked with fair facility, although they do not take a screw thread so well as ebonite. As a class they are not suitable for high voltage work owing to the liability of the varnish to absorb moisture from the atmosphere. Great care must be taken in interpreting the results of experiments carried out to determine the dielectric strength.

The alternating-current conductivity for nearly every insulator is greater than the direct current conductivity. For good dielectrics it may be from one and a half to three times as great, but for other materials it may be several thousand times as large. Hence when measuring the spark length which a given thickness of material will withstand before breaking down an alternating potential should always be used. If it be noticed that the spark fails at the gap, although the material is not punctured, this is due to the leakage through it by reason of the large alternating current potential, and the substance can be taken

to be unsuitable for alternating current work, especially high frequency circuits.

There are numbers of materials which, more or less, resemble ebonite, and are used as substitutes for it. They are trade preparations by various firms, and hence it is not possible to more than indicate their general nature. Some have high dielectric strength, although inferior to the best ebonite in this respect. The power to withstand a moderate rise in temperature and fair pressure renders their use of advantage in special cases.

The question of the best insulator to use for any particular purpose depends on a variety of circumstances.

Where high voltages are concerned, especially in high frequency circuits, only porcelain or the best ebonite can, with safety, be employed.

For instruments such as radio-telegraphic receivers or the many varieties of electrical measuring instruments, ebonite is used in almost every case in which its cost is not prohibitive or where its contraction with heat or reduced surface insulation after exposure to light renders it unsuitable.

---

## Administrative Notes

---

### Australia.

We are informed that, in accordance with the scheme approved by the International Time Commission of Paris, Melbourne radio-station is now transmitting time signals at the hours of noon and midnight, Melbourne time—which is ten hours ahead of Greenwich mean time. Full particulars of the manner in which these time signals are emitted will be found on pp. 557-560 of the *Year-Book of Wireless Telegraphy and Telephony* for 1914.

\* \* \*

### Panama.

The new powerful navy wireless station at Darien in the Panama Canal Zone has been completed and is now undergoing tests. For

some time the Darien Station has been receiving messages, but has not been able to communicate with any of the stations in the United States. It is said that the operators at Darien have been able to hear the war bulletins that are nightly sent from Germany to the wireless station at Sayville, Long Island.

When in working order this new station will form one of the many that the American Navy Department is constructing in different insular possessions. It will be manned and controlled by the navy, and has three 600-ft. towers and a capacity of 100 kilowatts. The other stations which will form links in the great navy wireless circuit will be located in Guam, Honolulu, Alaska, Porto Rico and Manila.

### South America.

The Rio de Janeiro offices of Marconi's Wireless Telegraph Company, Limited, have been removed to 37 Rua Visconde de Inhauma, which is opposite to the headquarters of the Ministry of Marine. It is near the offices of the Royal Mail Steam Packet Company and at the corner of the Visconde de Inhauma and the Primeiro de Marco. The postbox address remains the same—viz., Caixa Postal 126.

\* \* \*

### Austro-Spanish Wireless.

Since March 22nd a radio-telegraphic service has been established between the Austrian seaboard on the Adriatic and the Spanish station at Barcelona. The tariff is 29 centimes per word.

\* \* \*

### Tripoli.

The American Consul reports that before the Italian advent in Tripoli there was no

wireless equipment in this district, but after they landed twelve installations were set up to replace the telegraph system which was practically destroyed during the war. The instruments are of the Marconi system, and the type most used is the 1½-kw. musical spark station, which, designed for car transport, has been adapted for carriage by camel.

\* \* \*

### United States.

It is reported from New York that plans are being prepared by experts of the U.S. Navy Department for the establishment of a wireless telegraph station on Cape Cod, which will be equipped with an apparatus specially designed to give assistance to ships groping their way up and down the Atlantic during dense fogs. The apparatus, although of foreign origin, has been perfected by an American naval officer in such a way that it will, it is claimed, be possible to locate a calling ship by the measurement of the radio waves and the aid of a compass.

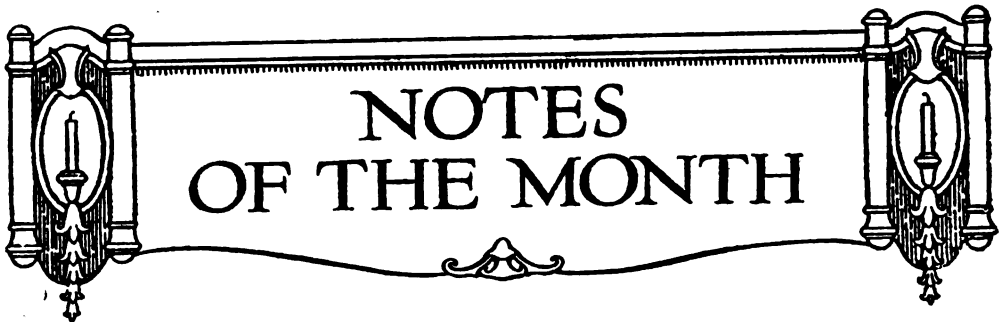

## NOTES OF THE MONTH

WE have recently received many letters of appreciation of our journal from the pens of constant readers, of which the following communication from Sapper M. F. Gantly, of the 24th Signal Company, Royal Engineers, is a type. He says "Pardon the liberty I am taking in writing to wish you every success in your new volume of THE WIRELESS WORLD. If the present volume is anything like its predecessors, it will indeed be interesting and instructive reading." It is encouraging to know that our efforts to meet the wants of our subscribers are bearing fruit.

A correspondent in the *South Bucks Free Press*, writing over the initials T. J. N., tenders some good advice to an advertiser in a previous issue of that journal. The latter sets himself down as one who "desires to perfect himself in wireless practice, and would much appreciate introduction to a gentleman with up-to-date knowledge of the profession." The advice tendered by the *South Bucks Free Press* correspondent runs as follows:

"If your advertiser is a young man of the right age I would advise him to join either the Army or Navy, where he would find scope for the development of his energies

“towards perfection. Or, he might attend one of the several good wireless telegraphy schools in London or elsewhere, and gain a thoroughly practical knowledge under expert teachers and by the aid of up-to-date Marconi apparatus, thus enjoying a course of instruction which would help to qualify him for the Postmaster-General's certificate. Thirdly, if he is like so many others of us, merely a scientific enthusiast, he could usefully apply his time to a study of the physical sciences, especially the branches dealing with electricity and mathematics, as applied to the theory and practice of wireless telegraphy. Much more genuine pleasure will always be derived in this way than the mere sucking of the brains of some good-natured person who has reached a certain measure of perfection by years of hard study and personal research.”

In view of the fact that such enquiries are constantly recurring, we hope shortly to publish more detailed instructions in our own pages. In the meantime, the general remarks of T. J. N. may be found useful.

\* \* \*

We should like to call attention to an interesting fact latent in the report of the Direct United States Cable Company presented at the annual general meeting held on Tuesday, April 27th, at Winchester House, London, E.C.

The Chairman, Sir James Pender, Bart., called attention to the fact that during 1913-1914 over £100,000 had been spent in connection with the cost of maintaining their cables. The report goes on to speak of other heavy expenditure in the same connection, and when we consider that for the sum of £100,000 an efficient long-distance wireless station could be erected capable, without heavy additional expenses for cable maintenance, of performing exactly the same services, we begin to realise the capabilities of wireless for decreasing the cost of cable messages whilst at the same time increasing their volume. The future expansion of trade and commerce is for this and for other reasons largely bound up with the future of radio-telegraphy.

\* \* \*

A Dutch inventor residing near Amsterdam has invented a simple little telephone, the receiver and transmitter of which are

so small that they can be easily carried in the vest pocket, taking up no more space than an ordinary watch. The cost of manufacture is estimated at 1s. 2½d. In spite of its diminutive size this “thermophone”—as the inventor has named it—appears to transmit messages with perfect clearness and distinctness, localisation being particularly good, and there is no confusion of vowel sounds, letters or figures. The receiver is so small that it may be placed within the ear, connection being maintained by a thin wire. Either a single or double receiver may be used, and the hands are left free to make notes of any messages transmitted. At a recent demonstration of the invention at the University of Utrecht the wireless telegraphy was brought into requisition in connection with the “thermophone” with entire success. Subsequently at the inventor's laboratory, the American Consul at Amsterdam, who was present at the demonstration, had the opportunity of transmitting and receiving messages to and from a distant room in the building over the ordinary wires.

\* \* \*

It is gratifying to note the increasing interest displayed by the general public in semi-technical “wireless” questions. A recent issue of our contemporary, *T. P.'s Weekly*, contained a letter from Mr. W. Davidson, of Glasgow, commenting on the fact that it is possible to transmit messages to, and receive them from, much greater distances at night than during the day. The writer of the letter suggests that the following may be a solution of this so far unexplained phenomenon. Light, he says, is transmitted from one place to another by means of ether waves; so also is the electric current sent out by the radio-telegraphic transmitter. During the daytime so many ether waves are required for light that the electric current does not get the same opportunity as during the night.

In a subsequent number of the same journal Mr. W. H. Marchant replies suggesting that the following, taken from the report of the lecture delivered by Dr. Erskine Murray before the Wireless Society of London, may be of interest and assistance to Mr. Davidson:—

“A first and most important property of waves, especially in wireless, was to understand that they can cross each other at any

"angle whatsoever without in the least disturbing each other. This was demonstrated in an interesting way by ripples on water. Dr. Murray said this explained why any number of sending stations near one another do not interfere with each other.' It will be seen from this that the shorter range of a radio-station during the daytime is not due to the interference of two sets of ether waves. There is no general agreement among radio workers as to the cause of the greatly increased range at night. One theory is that it is due to the ionisation of the atmosphere by sunlight, which by making the air partially conductive absorbs some part of the energy radiated. Another theory—and one which seems to find greater acceptance—is that the increased distance is due to reflection from the upper stratum of the atmosphere which is conductive. During the hours of darkness the lower surface of the conductive stratum is sharply defined, and is therefore a good reflector, but during daylight hours the transition from the conductive to the non-conductive is gradual, with the result that clear reflection is impossible."

Mr. Marchant adds that a very interesting article by Dr. Murray on this subject appears in the *Wireless Year Book* for 1914.

Our weekly contemporary, the *Nation*, in its issue of May 1st, contains a letter signed Hugh Richardson, suggesting "a public world-wide wireless news service" to which every Government might undertake to supply verified news. The function of the private news agency under this suggestion would be to "supply details." For our own part we should have imagined that one of the most striking lessons to be learnt from the present war from the point of view of newspapers was that of "preserve us from Governments"! With the best intentions in the world (for which we are willing to give all credit) it is difficult to imagine anything more fatuous than the handling of news items by public officials. Various Departments of State are affected by the different classes of news, and a State official before passing anything out for publication, would have to consult every Department which considered itself inte-

rested. The wireless news in peace time would, under such arrangements, contain matter as little new and information as vague as what we now have to put up with in war time. "*Absit Omen!*" It is far better that "a cobbler should stick to his last" and that *Governments* should occupy themselves with the task (in which they are none too successful) of *governing*. They would be well advised to leave to news agencies the task of providing that which affords the latter their only excuse for existence. \* \* \*

We notice in the issue of *John Bull* of May 1st that Mr. Horatio Bottomley considers the British Government would have been wise not to "let the enemy know that we are tapping their despatches." Of course, if any action or inaction by the British Government would have resulted in throwing the Germans off their guard and feeding them up with the illusion that their messages were not being tapped, no doubt we might have caught that very wide-awake nation napping, and have extracted all sorts of valuable information *without their knowledge*. But, despite the primitive, savage violence of German "kultur," to exhibitions of which we are being constantly treated, their knowledge of science is very far from primitive. Those responsible for Teutonic wireless messages could not under any circumstances have failed to realise every possibility affecting their utilisation of this wonderful application of modern science. Of course, the great bulk of the "news" bulletins sent out by them are intended for the consumption of neutral nations. \* \* \*

At the Electrical Show, opened at Urbana, Ill., on April 8th by the students of the University of Illinois, there were several novel devices which attracted considerable attention. Among these the demonstration of wireless control of an automobile was perhaps the most interesting thing in its way ever introduced by students. It is similar in operation to the work of the son of John Hays Hammond, who controlled by means of wireless a small ship off the Massachusetts coast. Another interesting feature was an electrical café, equipped by the students, wherein the cooking, lighting, and serving was all done by electricity.



# Maritime Wireless Telegraphy

A RECENT judgment in the Admiralty Court recalls how wireless was employed to summon aid which saved not merely the lives of those on board, but the whole hull and contents of a big steamer with her valuable cargo between Christmas Eve and New Year's Day of this year. The substantial amount of £5,400 was awarded to the owners, master, and crew of the Liverpool steamship *Raphael* for this notable piece of salvage work. It would appear that the *City of Lincoln* was so battered by storms off Cape Finisterre, that she was obliged to follow up her "S O S." call (after finding it answered by the *Raphael*) with an appeal stating that her machinery was helpless, her rudder stock broken, and that she was in serious danger of being driven by the terrific tempest then raging on to the rocky shores off Finisterre. The *Raphael* went to her assistance, and encountered considerable difficulty in preserving the steamer in distress. Tow ropes, and even wire hawsers, kept continually breaking, and the passengers on the *City of Lincoln* passed an extremely anxious Christmastide. The *Raphael*, en route to New Orleans to ship horses for the French Government, was carrying 33 French rough-riders, who gave considerable assistance in the course of the salvage. The *City of Lincoln*, described by counsel as "a veritable treasure ship," was bringing



Mr. T. D. Sandham.

passengers, tea, and rubber from Calcutta to London. Ship and cargo were valued at over £350,000. Of the £5,400 salvage award £4,000 went to the owners, £400 to the captain, and the rest was divided amongst the officers and crew and those who took part in the operations. It is a noteworthy fact that Sir Samuel Evans, the President of the Court, was sufficiently impressed with the share of credit due to the two Marconi operators that he made them special allowances.

The operators on the *Raphael* concerned in this adventure were Mr. A. H. L. Mills and Mr. B. A. Gardner, the former an old pupil of the Mercers School, High Holborn, who joined the Marconi staff in May, 1914; the latter, an operator employed by the Marconi Company of America, attached to the *Raphael* at the time as second man. We print a photograph of Mr. Mills, as well as one of Mr. T. D. Sandham, the wireless operator of the *City of Lincoln*, who joined in February, 1913. That of the gallant young American is, we regret to say, not available.



Mr. A. H. L. Mills.

The sum of £4,000, which constituted the owners' share, must, even in the calculations of the most commercially-minded steamship proprietors, have *amply justified the expense of installing wireless on their steamers*—the amount named would go far towards defraying the expense of equipment on quite a number of vessels.

\* \* \*

During the terrific gale which occurred off the Atlantic coast of the United States on April 3rd the Dutch West India liner *Prins Maurits* is believed to have foundered with all hands. With her own wireless apparently out of commission or of insufficient strength to reach shore stations the distress signals were communicated to a British cruiser in the first instance and thence to a shore station at New York. A few minutes before 9 o'clock on the morning of the disaster the operator on duty at the land station heard the cruiser signal for all vessels and land stations to stand by preparatory to sending out the call of distress, and a few minutes later the following message was received at New York: "*Prins Maurits* is in distress and badly in need of assistance in latitude 36.30 north, longitude 74.49 west."

After repeating the message the cruiser stopped sending and nothing further was heard from her for several hours. In the meantime messages from the New York station were received by the steamships *Algonquin*, *City of Memphis*, *City of Montgomery*, and *Princeton*, all of which signified their intention of going to the distressed vessel's assistance. Owing to the severe storm raging southward along the Atlantic coast communication by wireless was extremely difficult, and it was not until noon that the cruiser was heard from again. At 10 o'clock the same night Cape Hatteras reported to the New York station that nothing had been heard of the *Prins Maurits*, although several vessels had heard weak wireless signals which they believed came from the disabled vessel. The *Alliance* and *City of Atlanta* were in the vicinity of the position given by the cruiser, but they could find no trace of the *Prins Maurits*, although they repeatedly called her by wireless. Such tremendous seas were running, it was reported, that had the distressed vessel been found it would have been impossible to take off her passengers and crew. Careful search

was made for several hours in the vicinity of the position given by the *Prins Maurits* in her call for help, but no trace of the vessel could be found.

The *Prins Maurits*, which was in command of Capt. H. J. van der Goot, left New York on April 1st for ports in the Caribbean Sea and carried a full cargo and four passengers. The wireless operators on board the ill-fated ship were J. H. Karreman and F. V. S. Kinch, notes about whom will be found in our Personal columns.

\* \* \*

The extremely difficult work which from time to time is undertaken by lighthouse tenders calls for navigation and seamanship of the highest order. Wireless telegraphy, which has proved such a boon on ships both large and small, is now being applied by the United States Government to the boats which ply to and from the lighthouses on her coasts. Wireless equipments are to be placed on five of these tenders, two on the Atlantic and Pacific coasts, and one in Alaska.

### MARCONI HOUSE RIFLE CLUB.

THE first Club Handicap Competition was held in March. Silver spoons were won by Mr. A. T. Polden (Engineers' Drawing Office) and Mr. A. W. Torode (Accounts Department) on the handicap result, and by Mr. G. A. Johnson (Accounts Department) for the best score without handicap. Mr. Johnson's score was 91 out of a possible 100.

A second handicap competition was held in April, spoons being won by Mr. S. Anselmi (Engineers' Drawing Office) and Mr. C. H. Hall (Relay Telephone Company) on the handicap result, and by Mr. F. K. May (Managers' Department), with a score of 92 out of a possible 100. There were 30 competitors, and the shooting generally on this occasion showed a great improvement.

In our issue for April we had the pleasure of announcing the nomination of Mr. A. A. Campbell-Swinton for a fellowship in the Royal Society. The election is now consummated and it gives us much pleasure to tender congratulations on behalf of ourselves and our readers to Mr. A. A. Campbell-Swinton, F.R.S.

CARTOON OF THE MONTH



*Transmitting the Hymn of Hate.*

# The Wireless Transmission of Photographs.

By MARCUS J. MARTIN.

## Article 3.

**T**HERE are two other possible means of receiving that upon investigation may yield some results, but it is doubtful whether the current available, even that obtained from a telephone relay, will be sufficient to produce the desired magnetic effect, and the insertion of a second relay would detract greatly from the efficiency by decreasing the speed of working. If rays of monochromatic light from a lamp, L, Fig. 29, pass through a Nicol prism, P (polarising prism), then through a tube containing CS<sub>2</sub> (carbon bisulphide), afterwards passing through the second prism, P' (analysing prism); if the two Nicol prisms are set at the polarising angle no light from L would reach the photographic film wrapped round the drum, V, of the machine. Upon the tube being subjected to a field produced by a current passing through the coil, C, the refractive index of the liquid will be changed, and light from L will reach the photographic film.\*

The second method is rather more complicated, and is based upon the fact that the cathode rays in a Crookes' tube can be

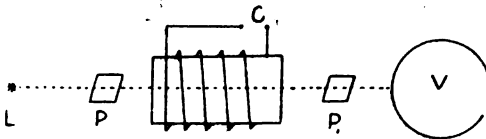

Fig. 29.

deflected from their course by means of a magnet. In Fig. 30 the cathode, K, of the X-ray tube sends a cathode-ray discharge through the aperture in the anode, A, through a small aperture in the ebonite screen, J, on to the drum, V, of the machine, round which is wrapped a photographic

film; A and K being connected to suitable electrical apparatus. Upon the coil being energised the cathode-ray is deflected from its straight line course, and the drum, V, is left in darkness.

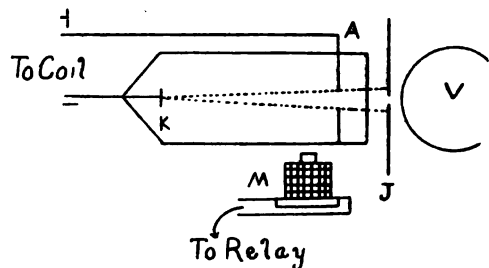

Fig. 30.

The method which is now going to be described is very ingenious, and it makes use of what is known as an electrolytic receiver. This method of receiving has proved to be the most practical and simple of all the photo-telegraphic systems that have been devised. The application of this system to wireless work is as follows: The aerial, A, and the earth, E, are joined to the primary, P, of a transformer, the secondary, S, being connected to a Marconi valve receiver, C. The valve receiver is connected to the battery, B, and quartz thread, K, of an Einthoven galvanometer (already described). The thread, K, is about 1/12,000 part of an inch in diameter, and will respond to currents as small as 10<sup>-8</sup> of an ampère. The light from M throws an enlarged shadow of the thread over a slit in the screen, J, and as the thread moves to one side under the influence of a current the slit in J is uncovered, and the light from M is thrown upon a small selenium cell, R. In the dark the selenium cell has a very high resistance, and therefore no current can flow from the battery, D, to the relay, F. When the

\* A description of the apparatus required will be found in Ganot's *Physics*.

string of the galvanometer moves to one side and uncovers the slit in the screen, J, a certain amount of light falls upon the selenium cell and lowers its resistance, allowing sufficient current to pass through to operate the relay. Round the drum, V, of the machine (shown in Fig. 12) is wrapped a sheet of paper that has been soaked in certain chemicals that are decomposed on the passage of an electric current through them. As soon as the local circuit of the

as, besides being absorbent enough to remain moist during the whole of the receiving, the surface must also remain fairly smooth, as with a rough paper the grain shows very distinctly, and if there is an excess of solution the electrolytic marks are inclined to spread, and so cause a blurred image. The writer tried numerous specimens of paper before one could be found that gave really satisfactory results. It was also found that when working in a warm room the paper

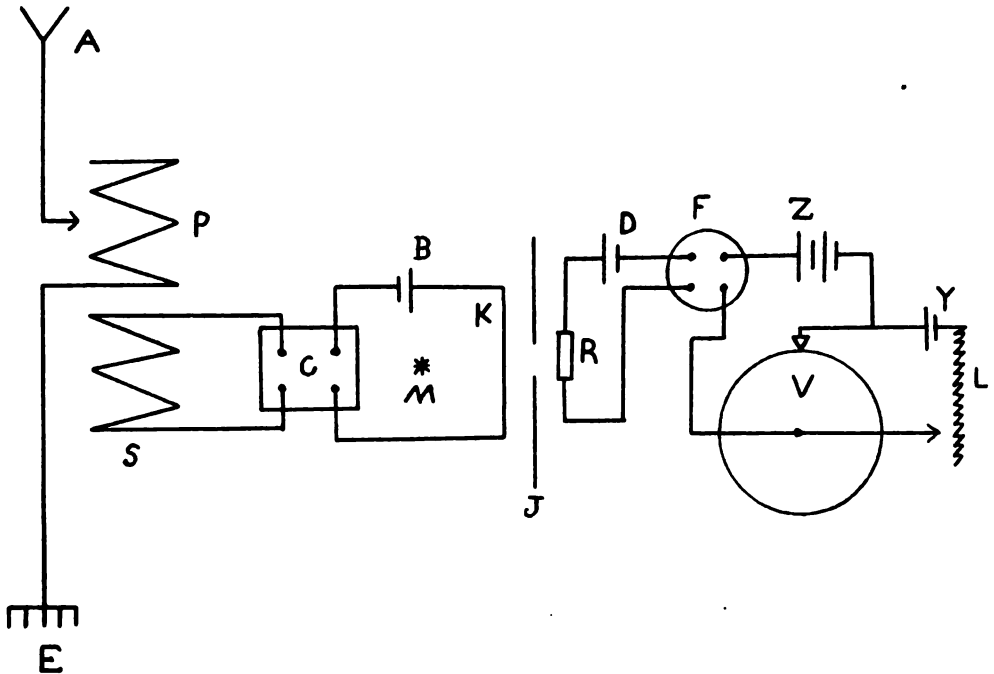

Fig. 31.

relay is closed the current from the battery, Z (about 12 volts), flows through the paper and produces a coloured mark. The picture therefore is composed of long or short marks, which correspond to the varying strips of conducting material on the single line print. In order to render the marks short and crisp a small battery, Y, and regulating resistance, L, is placed across the drum and stylus. The diagram Fig. 31 gives the connections for the complete receiver. The paper used is soaked in a solution consisting of ferrocyanide of potassium  $\frac{1}{4}$  oz., ammoniac nitrate  $\frac{1}{2}$  oz., and distilled water 4 oz.\* The paper has to be very carefully chosen,

became nearly dry before the receiving was finished, and the resistance being greatly increased, the marking became very faint. A sponge moistened with the solution and applied to the undecomposed portion of the paper while still revolving was found to help matters considerably. Another experience which happened during the writer's early experiments, the cause of which he is still unable to explain, occurred in connection with the stylus. The stylus used consisted of a sharply pointed steel needle, and after working for about three minutes it was noticed that the lines were gradually becoming wider, finally running into each other. Upon examination it was found that the point of the needle had worn away

\* Great care must be exercised in using this solution, as it is exceedingly poisonous.

considerably, becoming, in fact, almost a chisel point. Nearly every needle tried acted in a similar manner, and to overcome this difficulty the stylus shown in Fig. 32 was devised.

It will be seen that it consists of a holder, A, somewhat resembling a drill chuck, fastened to a flat spring, B, in such a manner that the angle the stylus makes to the drum can be altered. The needle consists of a length of 36 gauge steel wire, and, as this wears away slowly, the jaws of the holder can be loosened and a fresh length pushed through. The wire should not project beyond the face of the holder more than  $\frac{1}{8}$  inch. The gauge of wire chosen would not suit every machine, the best size to use being found by trial; but in the writer's machine the pitch of the decomposition marks is much finer than in the commercial machines, and this gauge with the slight but unavoidable spreading of the marks will produce a line of just the right thickness. As already mentioned, no explanation of this peculiarity on the part of the stylus can be given, as there is nothing very corrosive in the solution used, and the pressure on the paper is so slight as to be almost negligible.

No special means are required for fastening the paper to the drum, the moist paper adhering quite firmly. Care should be taken, however, to fasten the paper (which should be long enough to allow for a lap of about  $\frac{1}{4}$  inch) in such a manner that in working the stylus draws away from the edge of the lap and not towards it.

The current required to produce electrolysis is very small, about one milliampère being sufficient. Providing that the voltage is sufficiently high, decomposition will take place with practically "no current," it being possible to decompose the solution with the discharge from a small induction coil. The quantity of an element liberated is by weight the product of time, current, and the electro-chemical equivalent of that element, and is given by the equation  $W = z c t$ ,

where  $W$  = quantity of element liberated in grammes,

$Z$  = electro-chemical equivalent,

$C$  = current in ampères,

$T$  = time in seconds.

The chemical action that takes place is therefore very small, as the intermittent current sent out from the transmitter in some instances only lasts from 1/50 to 1/100 part of a second. The decomposed marks made on the paper are blue, and, as photographers know, blue is reproduced in a photograph as white, so that a photograph taken of our electrolytic picture, which will, of course, be a blue image on a white ground, will be reproduced almost like a blank sheet of paper. If, however, a yellow contrast filter is placed in front of the camera lens, and an orthochromatic plate used, the blue will be reproduced in the photograph as a dead black.

There is one other point that requires attention. It will be noticed that the metal print used for transmitting is a positive, since it is prepared from a negative. The received

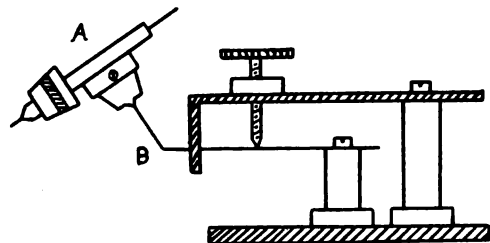

Fig. 32.

picture will, therefore, be a negative, making the final reproduction (if it is to be used for newspaper work) a negative also. Obviously, this is useless. The final reproduction must be a positive, therefore the received picture must be a positive also. To overcome this difficulty matters must be so arranged at the receiving station that in the cases of Figs. 21, 22 and 25 the film is kept permanently illuminated while the stylus on the transmitter is tracing over an insulating strip, and in darkness when tracing over a conducting strip. In Fig. 31 the relay, F, should allow a continuous current from Z to flow through the electrolytic paper and only broken when the resistance of the selenium cell is sufficiently reduced to allow the current from E to operate the relay.

The writer has endeavoured to make direct positives on glass of the pictures to be transmitted, so that a negative metal print could be prepared. The results obtained were not

very satisfactory, but the method tried is given as it may be of some interest. The plate used in the copying camera has to be exposed three or four times longer than is required for an ordinary negative. The exposed plate is then placed in a solution of protoxalate of iron (ferrous oxalate) and left until the image shows plainly through the back of the plate. It is then washed in water and placed in a solution consisting of :

Distilled water	...	...	...	1,000 c.c.
Nitric acid	...	...	...	2 c.c.
Sulphuric acid	...	...	...	3 c.c.
Bichromate of potash	...	...	...	105 grammes
Alum	...	...	...	80 grammes

After being in this bath for about 15 minutes, the plate is again well washed in water and developed in the ordinary way. The first two operations should be performed in the dark room, but once the plate has been placed in the bichromate bath the remaining operations can be performed in daylight. As already stated, the results were not very satisfactory, and such a method is not now worth following, as it is comparatively easy so to arrange matters at the receiving station that a positive or negative image can be received at will.

It is necessary to connect the stylus of the receiving machine to the positive pole of the battery Z, otherwise the marks will be made on the underside of the paper. The electrolytic receiver, owing to the absence of mechanical and electro-magnetic inertia, is capable of recording signals at a very high speed indeed.

None of the methods of receiving that have been described can be said to have really solved the problem, as at present they are only in the experimental stage. What is really required is a relay sensitive enough to work on the minute currents obtainable from the various detectors, such as the carbondum crystal, galena-graphite, electrolytic, etc., that are in use at the present time. The only practical instrument that at present can be used with these detectors is a high-resistance telephone. The reason why none of the telephonic detectors are suitable for operating a relay of the ordinary type is that the alteration of their resistance only lasts for a very small fraction of a second, and the relay mechanism is too massive to follow the very transient current produced.

The next article will deal with the subject of driving and synchronising the two stations.

## Doings of Operators.

WE print below an extract from an interesting communication sent us by Mr. Walter Condon, wireless operator of the s.s. *Sachem*, which will explain itself.

"I was very fortunate in obtaining the accompanying photograph from the bridge



Iceberg as seen from s.s. "Sachem."

of the s.s. *Sachem* while on the homeward voyage from Boston to Liverpool. It was about 2.30 p.m. apparent time at ship, and the approximate position was latitude 42.35 N, longitude 49.50 W. Thick fog had prevailed for two successive days, with just a few intermittent clearances, and it was during one of these clearances that this iceberg was observed. I was warned of the positions of ice by the United States Government patrol ship *Miami* and the Holland-American Liner *Rotterdam*, who was proceeding to New York. Although in dense fog we knew we were in close proximity to ice on account of the intense cold and the very low temperature of the water. Ice is always a source of anxiety to commanders of Western Ocean liners, especially when accompanied by fog, and they have frequently expressed the wish that if they could only clear the ice track they would not worry about the German submarine blockade."



# CODE

*A story of an intercepted message  
and what came of it.*

By J. W. T. WALSH.

## I.

### THE MESSAGE AND ITS MEANING.

“NOTHING much doing to-night,” said Roger Blake, as he handed over the ‘phones to his friend and fellow-enthusiast, Jack Faucet.

They were sitting in a small shed at the bottom of the garden where John Faucet had rigged up a small receiving set in his spare time. Spare time was a commodity rather scarce to a young doctor with a fairly extensive practice in a small isolated country town like Armidale, but Faucet was one of those keen men who can always find time for doing anything they have set their heart upon. He had come down from the ‘Varsity full of enthusiasm for wireless and with a firm resolve to have a receiving set of his own as soon as he could find an opportunity of putting one together. The outcome of this resolve and the fruit of many months’ patient labour was a very creditable receiving station, with which he used frequently to amuse himself by trying to pick up any messages that might be floating about the ether.

Blake had been his particular chum at college, and both had been signallers in the Officers Training Corps. As a result they had rapidly fallen under the fascination of the “dot-dash-dot.” Many a pleasant evening had they spent in each other’s rooms, practising with a dummy-key or buzzer, and both, before they said good-bye to ‘Varsity life, had become quite proficient amateurs in the gentle art of Morse-reading.

While Faucet was going through the Hospital they had only seen each other at wide intervals, but now that he had settled

down to practice their meetings were more frequent. Blake, whose profession carried him from place to place, so that he had no settled home, always looked forward to a short stay with his old chum whenever he got a few days’ leave, and it would be impossible to say which of them most enjoyed these reunions. They could then compare notes and talk about old times and all the fellows whom they used to know at college, but who had since drifted out of sight. An added attraction, of course, was the wireless set, and to-night they had been sitting together in the shed taking it in turns to listen to whatever might be going on.

There was not much doing. FL had not yet begun to send out news, while KAV was rather indistinct—besides which, they were neither of them great German scholars. It was a favourite trick of Faucet’s to “sweep” for signals; that is, he would travel along the whole gamut of wavelengths on the off-chance of picking up any stray messages that might be audible. As he took the ‘phones the idea came into his head to try this now.

For a few minutes there seemed to be nothing about, and Blake was just going into the house for two cups of something warm—the shed was rather exposed, there was a fairly strong wind blowing, and the temperature was that of a cold, bleak November night—when he was stopped by an exclamation from Faucet, whose attention had suddenly been attracted by a faint call. It was sharply tuned on an unusual wavelength, and if he had not been purposely “sweeping” for messages he would un-



doubtedly have missed it. Rapidly he began to take it down:—

“ . . . ace by hew dress aver visit enim  
dieser travelled passe an atom break all all  
at crowing ail a gash outer his above een  
ambrose to honor errat errat add eye action  
train tremor moon a faible log a dice sky  
ash ate none none all leave none 52197065.  
323580 — . . . — CCC . . . — . . .  
— . . . — . . . — ” Then everything relapsed  
into silence.

“ You don't seem to have picked up much after all, Faucet,” said Blake, as he looked over the result of his friend's efforts. “ Some amateur practising sending, I suppose.”

“ It certainly looks like it,” agreed Faucet, “ but the funny part of it is that the sending was not at all like an amateur's. It was perfectly regular and deliberate all through, without any clipping or dragging. I'm sure I couldn't have sent half as well. Besides, why should he practise sending on his transmitter at all? Hasn't he got a buzzer or something else he can use without annoying other people? And what is the meaning of those three C's at the end? That isn't a miscellaneous signal, is it?”

Quick as thought he took down the Signalling Manual and looked it up.

“ No, I thought as much; there is no such signal as CCC. It bears a faint resemblance to the cipher signal, doesn't it? By Jove! I wonder if it's not as stupid as it looks. The question is——”

“ Lend it me for a minute, will you?” said Blake. “ I used to be rather a 'nut' at deciphering codes in my younger days, but I expect I'm a bit out of practice now! Let me think a minute. It can't be a simple letter transposition because the groups are real words. That puts all those complicated keyword ciphers out of court, too, and I only know of three other systems in general use. In one of these each word or phrase has its own code word to represent it, so that you need a code book to decipher a message of that kind. I don't think that is the system they have used here, because, you see, in no less than three instances there is a word repeated, and one does not often intentionally use the same word twice running in an ordinary message. Another wheeze is simply to leave the words of the message in clear and mix them up as if you had put them all in a hat and drawn them out



*Both seized their hats and made for the Police Station.*

haphazard. That, however, is rather a risky practice if any of the words are at all distinctive, and here we have a mixture of four different languages, so I think that, too, is out of the question. The only other system I know of is the simplest of all, and a very favourite one with the amateur cryptographer who doesn't want to be bothered with a key or other paraphernalia. He just puts in a lot of unnecessary letters according to some prearranged plan, so that he gets a series of words which, at first sight, don't look like a code message at all. That is one of the advantages of the system. All the reader has to do is to pick out the letters at stated intervals, when the message appears in clear at once. This is most probably the system they have used here; at any rate, I mean to try it and see how it works. Let's take the first few words for a start and run them all together so: ' . . . acebyhewdressavervisitenimdiesertravelled . . . ' Now put down every other letter. This gives us either ' aeyedesvriieideetaeld ' or ' cbhwrsa-evstnmisrrvle. ' Neither of those is any good. Now try every third letter. Starting with the ' a ' we get ' aberseitierec, ' which

is no better than the other two. The 'b' gives us 'cywearsemerald'—Hallo! What's this? Now, I think, we have found the key," and rapidly he proceeded to write out the remainder of the message.

Faucet, looking over his shoulder, quickly cut up the string of letters into its component words and read as follows: "... cy wears emeralds at ball to-night have motor ready corner of Blackstone Lane 10.30."

Even as he read it the extraordinary nature of the message flashed across the minds of both men, and, as if by a single impulse, each looked at the other and exclaimed "What on earth does this mean?"

Light came rapidly.

"It seems to me," said Blake, "that we have somehow stumbled upon a message meant to be read by no one but the man to whom it was sent. That mention of a motor in the consequent when the antecedent contains the word 'emeralds' is suspicious, to say the least of it. What a pity you didn't get the whole message, Jack!"

"It certainly does look fishy," agreed Faucet, "but as things stand I don't see what we can do. That '... cy' at the beginning is most tantalising. Anyway, I suppose we ought to let the police know of our discovery and perhaps they may be able to make a better guess than we can as to the missing portion. We'd better look sharp, too. It's nearly 10 o'clock now, and the reference in the message is to 10.30, so we haven't a second to spare."

Quickly Blake turned out the light and locked up the shed, while Faucet went into the house to tell his landlady that they were going out for a short stroll before turning in for the night. As soon as Blake came in, both seized their hats and made for the Police Station faster than either of them had run for the last five years or more.

## II.

### THE CHASE AND ITS CONCLUSION.

Arrived at the station, Faucet quickly explained the matter to the inspector in



*Round a bend in the road there came into sight a lumbering country cart.*

charge, who was at first inclined to be sceptical, scenting a possible hoax with unpleasant "consequences" from headquarters. On the other hand, there might be something in it, and, if so, it seemed to offer chances of distinguished service, chances so often wished for, and so seldom obtained, by the police inspector of a small country town. Drunkenness, petty thefts, desertions, and poaching formed the usual routine. But here, to all appearance, was something conceived on a grander scale than anything he had previously dealt with, something that would create a momentary sensation, with perhaps a column in the London papers and certainly a page or more in the local *Gazette*.

Even the wild possibility of seeing his photograph at the head of a lurid description of an exciting chase and capture entered the inspector's head and refused to be dislodged. Chances of promotion, moreover, were few and far between, and his present salary barely adequate to the needs of a steadily growing family. Finally, he decided to take the risk.

The interpretation of the message gave no difficulty. Blackstone Lane he knew well for a lonely country road about 15 miles from Armidale on the main road to Gesborough. It was absolutely deserted at night, and the very place to hide a motor. Close by was "The Grange," the country seat of Lord Dacy, and one of the largest houses in the county. The inspector took down a book and searched for a few minutes. What he found there obviously scattered any remaining doubts as to the genuineness of the message, for there was no hesitation in his manner as he asked the two friends whether they would like to see the matter to its conclusion. With alacrity both accepted, and in a very short time they were seated with two constables in a motor-car rapidly driven by the inspector along the Gesborough Road.

For a quarter of an hour no one spoke as they tore along the deserted road. Half-past ten and they were still five miles from Blackstone Lane, when they saw a large car coming towards them at a speed almost equal to their own. Could that be the car they were in search of, or was it some visitor returning early from the ball?

Quick as thought the inspector slowed the

car down until she was almost at a standstill; then steered her across the road as if he were trying to turn round, so that he temporarily blocked the passage of the oncoming car. He could hear the grind of her wheels skidding along the sandy road as her driver jammed the brakes on. Then from within the motor an impatient voice, which the inspector recognised as that of one of the wealthiest residents of Armidale, could be heard inquiring in angry tones what was the matter. An apology from the inspector left nothing possible but a somewhat curt acceptance; the offending car was rapidly turned into her original direction, and both proceeded swiftly on their respective journeys.

"Lost us nearly ten minutes of precious time," growled the inspector, as he looked at the car's clock.

Another minute and they were in sight of the corner where Blackstone Lane entered the main road, and even as they looked they could see a large car without lights move slowly out of the lane and start off down the main road in front of them.

"There she is," came from between the inspector's closed teeth as he gripped the steering wheel and started in pursuit.

At first it seemed as if the occupants did not know that they were being followed, but as the car behind swept past the house without slackening speed and turning in as they expected, some suspicion seemed to cross them that all was not well, and their speed rapidly increased. Soon both cars were travelling at nearly the same speed. A few minutes more and then:

"She's gaining on us," jerked out the inspector as he saw the car in front slowly pull ahead.

Evidently hers were the more powerful engines.

But just at this critical moment the unexpected happened. Round a bend in the road there came into sight a lumbering country cart piled high with produce for the Gesborough market. The driver, with typical rural indifference to other traffic and in conformity with the usual practice of country carts, was calmly occupying the centre of the road. The driver of the first car made a frantic effort on the horn to clear a passage in time. Fruitless attempt to hasten that which was only meant to crawl! The



*A shot from the Inspector brought down the lighter man of the two.*

horses had scarcely begun to turn their heads when he was upon them. Swiftly he steered to try and pass, but there was no room. One of the front wheels dashed over the path and into the ditch at the side.

Seeing what had happened, the inspector jammed on the brakes just in time to avoid a collision. The fugitives, quickly realising the danger of the situation, quitted the car and made off down the road at their utmost speed. Their pursuers were not far behind.

The chase was short.

A shot from the inspector brought down the lighter man of the two who was in front, while Faucet, who in his college days had always carried off the sprinting races, was more than a match for the other, whom he secured single-handed. Both men were unarmed, having left everything in the car when they abandoned it.

A short search revealed a small attaché case under the seat of the stranded motor, and on opening this the inspector found, lying loose in the corner, the famous Dacy emeralds, which had been handed down in that family for countless generations.

The man in front, whom the inspector soon recognised as one of the most daring

and ingenious cracksmen known to the police, was not seriously injured. A very short time saw both men, handcuffed and with a constable apiece, in the police car with the inspector as driver. Meanwhile Faucet and Blake took charge of the other car, and with the help of two horses from the cart soon had her righted and on the road again.

While the inspector with his prisoners returned to Armidale, Faucet and Blake drove back to "The Grange," where they found everything in disorder and Lady Dacy in despair. A few words from Faucet to Lord Dacy, however, rapidly set all minds at ease, and then the two friends between them told the story of the secret message. At its close Lord Dacy came up to them, shook both men warmly by the hand, and expressed his gratitude in words of glowing admiration for the young lawyer's brilliant acumen and ready wit.

There is now a complete wireless station at "The Grange." Under Faucet's direction Lord and Lady Dacy have both taken up the fascinating study, and are now keen amateurs of the new science which saved for them the treasured heirloom of their house.

# Photo-Electric Phenomena

*The Tyndall Lecture at the Royal Institution on May 1st.*

THE Tyndall lectures at the Royal Institution were delivered this year by Prof. Fleming on May 1st and May 8th on the subject of Photo-Electric Phenomena.

As a lecturer Prof. Fleming has few equals. His delivery is emphatic, lucid and continuous. Few men can marshal and collect their facts so well, or use more efficiently the limited time at a lecturer's disposal.

Commencing with the researches of Hertz, published in 1887, on the Influence of Ultra Violet Light upon the electric discharge, he repeated Hertz's experiment, but instead of two induction coils in series he used one with two spark gaps in parallel, one gap being enclosed in a glass box, having above it the second gap, which had a slightly greater length and was not enclosed. When the key completing the induction coil primary circuit was pressed a spark took place at the discharger in the glass box, but no spark at the gap in parallel with it. When a second induction coil in the neighbourhood was working, however, the influence of its spark on the unenclosed gap was sufficient to make this gap spark.

But not only could the light from an electric spark produce this effect, the light from a carbon arc could do the same thing. It is not visible light which is effective in this way, for a glass screen transparent to visible light stops the effect, and so also does a screen of mica. But it is not interfered with by a quartz screen. A magnesium flare showed the effect very strongly, but the light from a candle gave no result. From a knowledge of the substances which permitted or produced this effect it was evident that it must be due to ultra violet light.

Hallwachs in 1888 showed that ultra violet light will discharge a negatively charged plate of zinc, but the experimental results obtained are very much dependent on the surface of the charged plate. Thus,

if one side of the zinc is dull and the other is highly polished, ultra violet light will discharge the polished side, but will have only a small effect in discharging the dull side. Prof. Fleming illustrated these results, using a sensitive but very practical form of electroscope of his own invention. In Fig. 1, E is an ebonite stand, B a brass

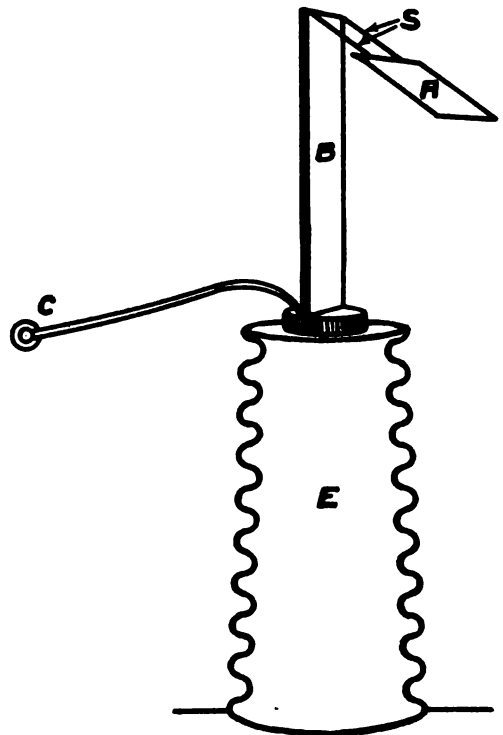

Fig. 1.

support, A a rectangle of thin aluminium wire, S two silk threads moistened with a solution of chloride of calcium, and C a charging wire. This electroscope gave excellent results, retaining its charge in unionised air for an indefinite period without the necessity of working with it under the usual glass cover. A sheet of copper gauze

charged positively was connected to the electroscope. When ultra violet light was thrown upon it, it still held its charge; but when the polished zinc was held behind the copper, and the ultra violet light after passing through the copper gauze fell on the zinc, the charge on the gauze began to fall. The ultra violet light set free the negative charge from the zinc which discharged the positive plate. This effect shown by the zinc could be shown by any metal which is highly oxidisable.

The loss of charge is due to the escape of negative electrons from the zinc under the influence of ultra violet light. In this way the material acted on becomes positively charged, and after a time the number of electrons thrown off decreases as those which would otherwise be set free are held back by the positive charge. It is therefore necessary to earth the active plate if the effect is required to be continuous. The resulting flow of electrons causes what is known as the photo-electric current.

The apparatus devised by Prof. Fleming for examining this photo-electric effect is roughly shown in Fig. 3, where S is a spark chamber, the electrodes being made of

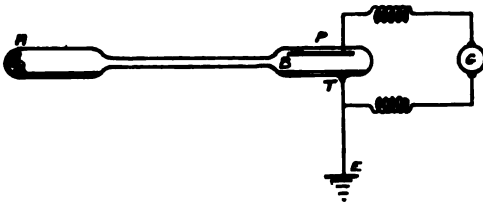

Fig. 2.

invar metal, a non-expanding alloy of nickel and iron. In the base of the chamber is a window of quartz, W, which can be closed by a shutter of cardboard. Below this is a pedestal, on which is placed the plate, P, whose photo-electric properties are to be investigated, and just above the pedestal is a positively charged ring of brass, R. An electroscope is connected to the ring, and an earth connection is made at the plate, and the discharge of the electroscope indicates the flow of electrons set in motion when ultra violet light which is sent off by the spark passes through the quartz window and falls on the plate.

Bodies which are photo-electric exhibit fatigue. Not fatigue in the ordinary sense, which ends in recovery after rest, but a

fatigue which shows itself after the bodies have been left inactive, say on a table—for a short time. They have to be scraped and repolished before they recover their old condition.

Materials can be arranged in the order of their photo-electric activity. It is found that this corresponds roughly with their order in the electro-chemical series—the most electro positive elements being the most photo-electric as follows:—

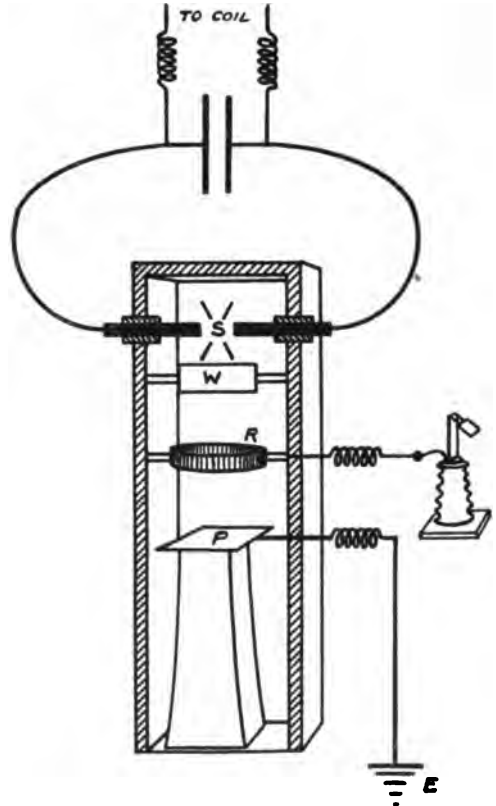

Fig. 3.

Rubidium	Lead
Potassium	Bismuth
Sodium	Gold
Aluminium	Nickel
Magnesium	Copper
Zinc	Silver
Tin	Molybdenum
Cadmium	

Turning to the compounds, Prof. Fleming stated that sulphides were very photo-electric. Galena (PbS) is not conductive enough as a powder to show this effect, but

when compressed at 50 tons per square inch into a block it is shown to be very active. On the other hand graphite or plumbago, which has a very similar appearance when polished, will not discharge.

Fatigue is caused by a film of air which settles on the plate like moisture on a glass and prevents the electrons from coming off. A plate left on a table for a few minutes loses from 50 per cent. to 60 per cent. of its activity. For this reason research must be conducted with these plates in vacuum, and a great deal has been done in this connection at Cambridge.

For every substance there is a limiting frequency of light wave-length below which the substance shows this photo-electric effect.

The more electro-positive the body the longer the wave-length which can produce a photo-electric current.

Prof. Fleming made use of a sodium-potassium alloy. He showed a tube, Fig. 2, containing the alloy; parts of each metal were

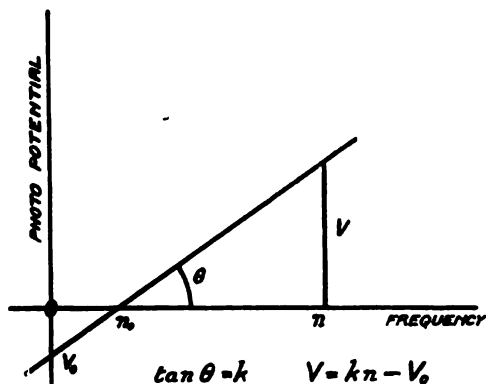

Fig. 4.

at one end, A, and the alloy—being a liquid at ordinary temperatures—was run off from the metals when formed, through the reduced part of the tube into the chamber beyond, B, where it made contact with terminals sealed in the glass, T. Above this liquid on the top wall of the chamber was a platinum plate, P, which was connected to a galvo and thence to the alloy which was earthed. In this way the photo-electric current passing between the alloy and the platinum as a result of the influence of light of appropriate wave-length could be measured. The alloy is of an explosive nature and

difficult to handle, but is very effective for the purpose of these investigations. Fig. 4 is a diagram showing the photo potential steady rise with increase of light frequency below a certain minimum,  $N_0$ , and for every

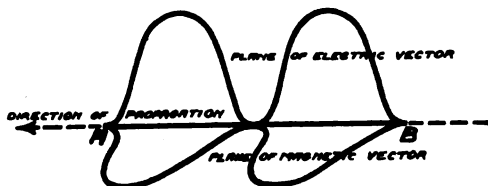

Fig. 5.

substance a constant can be determined given by the relation of working frequency below the limiting frequency, and the voltage.

The velocity of the electrons, or the potential, is independent of temperature and intensity of incident light, but it varies with the manner in which the light is polarised. Prof. Fleming used the sodium potassium alloy to show that no current resulted unless light of a wave-length below a certain minimum was used. Red light caused no movement of galvanometer spot, blue light produced a small movement, white light a considerable movement.

The potassium-sodium alloy is photo-sensitive to visible light, but zinc and magnesium only to ultra-violet light.

Prof. Fleming then referred to some questions on the nature of light. The electro-magnetic theory resolved it into two vibrations in planes at right angles

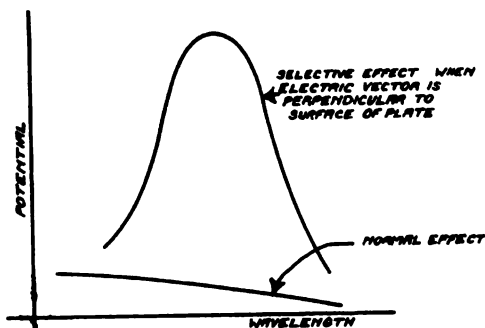

Fig. 6.

to each other. A cardboard model, Fig. 5, served to illustrate this. But instead of the electric vibrations always being in the same plane, one must consider that in ordinary light the plane is always changing,

that the wave in progressing has a sort of screw motion. The model must be supposed to move forward and at the same time to turn on its axis, AB. But it is possible to cause light to move in only one plane—to plane polarise it.

Then, if plane polarised light is used, it is found that the strongest effect occurs when the plate under test is in the plane of magnetic vibration, that is the largest deflection occurs when the electric vector is perpendicular to the surface of the sodium-potassium alloy (see Fig. 6).

Oxides are not very photo-electric. Some

in matter are divided into certain classes. Electric conductivity depends on the presence of free electrons between the atoms moving at a velocity of some 60 miles per second. Under normal conditions these movements are indiscriminate, much the same as a swarm of gnats, but on the application of an EMF these electrons are given a definite order of motion which results in an electronic current.

The question arises, are the electrons sent off by photo-electric activity, these conduction electrons? If it were so, then one would expect the conductivity of a photo-

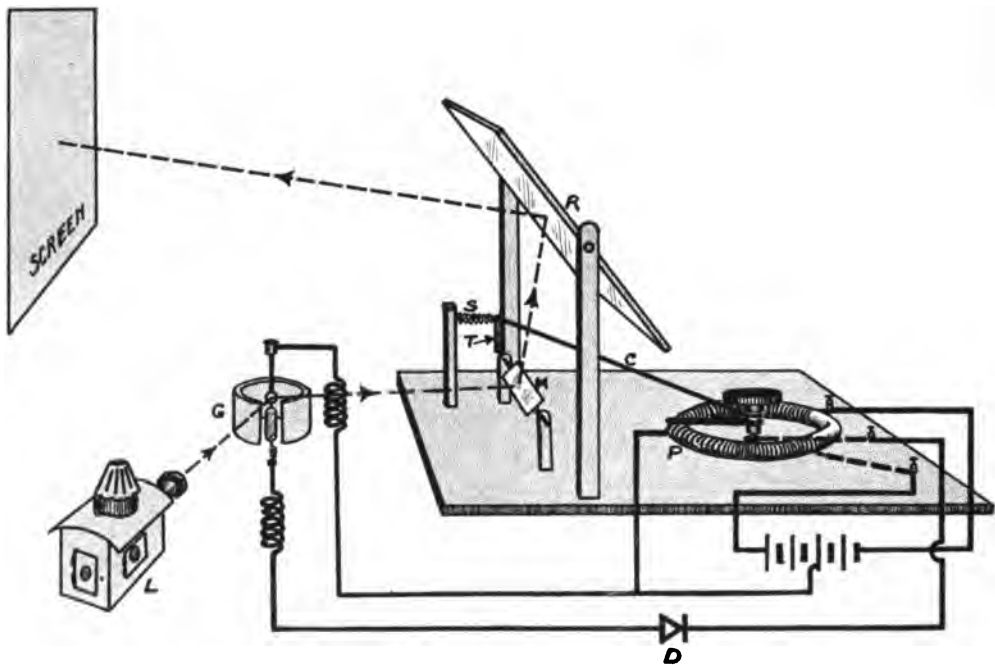

Fig. 7.

sulphides are twice as active as polished zinc. Chalco-pyrites or copper-iron pyrites are very photo-electric. All phosphorescent bodies are photo-electric. There is a close connection between the causes of the two effects. But, although many fluorescent bodies are photo-electric, one cannot say that because a body is fluorescent it will also be photo-electric. The connection is not so close as in the case of phosphorescence. Fluorescence transforms radiation of one frequency into another, the light which passes through the substance being different to the light it reflects. To explain electric effects electrons

electric body to fall. But in the case of selenium light increases conductivity. Prof. Fleming showed this result by means of an experiment with a galvanometer, two iron wires on a mica plate, and a blob of selenium uniting the two iron wires. The effect of light on the selenium caused a deflection of the galvanometer. Chloride, bromide and iodide of silver also increase in conductivity under the influence of light. Photo-electricity, therefore, must be due to the liberation of the internal electrons from the atoms. There is no difference in conductivity noted in ordinary metals, because the free electrons



are so numerous, their number being of the same order as the atoms themselves, so that any increase of electrons is inappreciable in the total number.

Coming now to the contact potentials between bodies, it is found that chalcopyrites and zincite conduct much better from chalcopyrites to zincite than the other way—that is, zincite negative and the chalcopyrites positive give the best conductivity. A similar effect is noticed between galena and plumbago. Why should these pairs of substances rectify an electric current?

Prof. Fleming has observed that one of the

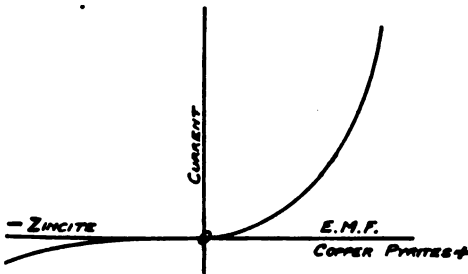

Fig. 8.

pair is always highly photo-electric and the other is not. Prof. Fleming then described an instrument he had designed and had exhibited recently to the Physical Society for the optical deliniation of curves having two variables, such as current and potential (see Fig. 7). A potentiometer winding, P, has its middle point connected to the middle point of the potentiometer battery. The moving arm is connected to the contact bodies under test and a galvanometer, the circuit being completed at the mid-point on the potentiometer.

With this arrangement the current can be sent either way through the contacts by moving the potentiometer arm to the right or left of the centre.

The current through the contacts, D, deflects the spot of light thrown on the mirror, M, by the galvanometer, and the mirror itself is tilted as the potentiometer is adjusted by means of a cord, C, pulling on the arm, T, against the spring, S, as it is wound up or unwound by the movement of the potentiometer handle.

It had been suggested that the instrument

should be called the "Campograph." The combination zincite negative copper pyrites positive known as the perikon detector, has a characteristic, as shown in Fig. 8. Zincite is not very photo-electric, but copper pyrites are distinctly photo-electric. Dr. Eccles has suggested that the rectification effect is due to thermo-electric action. Another theory is that it is a film effect at the junction which acts in the manner of a Lodge coherer. Prof. Fleming suggested a photo-electric explanation. The zincite is reluctant to give up its electrons, but the copper pyrites are ready to give them up. Therefore it is easy to pass a current from the pyrites to the zincite, but not in the opposite direction.

Several theories had been put forward to explain the photo-electric effect. The first one advanced was that the effect is due to resonance. A wave of a certain light frequency corresponding with the frequency of electron vibrations in the atoms would in time increase their amplitude so much that ultimately they would break away from the atom. But this explanation could not be true, as it was not light of one definite frequency which set the electrons free, but all light of a frequency greater than a certain minimum. A resonance effect certainly is suggested by the photo-potential curve for sodium-potassium alloy when the electric vector of the light is perpendicular to the surface.

Another suggestion is that the effect is a trigger action, a small amount of energy setting free a much larger amount. Here, again, one meets with difficulties.

The energy required to pull an electron out of an atom is about one-billionth of an erg, and if there are a thousand billion atoms in a square centimetre and light energy at the rate of one erg per square centimetre per second is applied to the zinc, it would have to be applied for a thousand seconds to pull out one electron. But the effect appears a very short time after the light is applied. Then light energy cannot be spread equally over the surface of the plate. One could explain the effect if the assumption were made that light is concentrated in certain places and in other places there is no light, and thus the total amount of work is done on a few atoms of the substance only, and only a few atoms respond.

This leads to the quantum hypothesis, which assumes that light energy is not emitted in a uniform stream, but in gushes, and in any one gush there may be parts of it concentrated and other parts attenuated so that the concentrated part could do what the average energy of the light could not do were it to be uniformly distributed.

The photo-electric effect then could be explained if there were concentration of energy either in time or space. Such energy could do what uniformly distributed energy could not do. However, a theory of light on this basis breaks down when it is required to explain interference, or the wave extin-

guishing effect. On the basis of the electromagnetic theory interference is simply explained as the occurrence of the trough of one wave simultaneous with the occurrence at the same place of the peak of another wave so that they mutually wipe each other out. Here the corpuscular theory of light fails.

The theory of Young, Fresnel, and Maxwell explains many light phenomena, such as diffraction, polarisation and interference, but it does not explain photo-electricity. On the other hand the quantum theory explains photo-electric phenomena, but there are many other effects it cannot explain.

## Ibero-Roman Intercommunication

*Fresh Facilities for Friendly Business Relations afforded by Wireless.*

THE linking of Spain and Italy by radio-telegraphy possesses a peculiar interest in view of the close relationship between the two peoples, both with regard to their race and their history. Italy is the home of the Roman Empire, the centre of the civilisation of the ancient European world; Spain, made the base for Carthaginian military operations by Hannibal, and conquered by Rome by the Scipios (father and son) in the third century B.C., formed one of her earliest overseas colonies, and has remained ever since united with her by the closest bonds. The very languages are perhaps as intimately linked as those of any other separate nationalities in Europe.

The Spanish station for this service, erected two or three years ago, when Spain first realised the importance of efficient wireless communication, has been located at Prat de Llobregat, near Barcelona—the second largest and most important manufacturing city in Spain; closely linked, moreover, by her history with the erstwhile immense Spanish colonial Empire. It was one of the first Peninsular cities into which printing was introduced. Columbus here received his famous audience by Ferdinand and Isabella after his discovery of the new world. At Barcelona also, as early as 1543, a ship was launched whose motive power

was steam. It will thus be seen that this beautiful and prosperous city constitutes a fitting home for the great wireless station which is destined to bind in closer touch the two great Latin Kingdoms.

Although it is probable that the bulk of the Spanish traffic will be transmitted through the Barcelona station, it has also been arranged for the high power station at Aranjuez (near Madrid) to play its part in the communication between the two countries. On the Italian side two stations are to be used for the service—one at Centocelle (Rome) and another at Spezia.

In the days when she was mistress of the world, Rome formed the heart of civilisation, the central point whence radiated the great arteries of administration and commerce, without which no organised community or, indeed, no civilisation is possible. In those pre-Christian days the arteries pulsing the life-blood of trade and intercourse between Rome and the remotest districts of her Empire were her great highways, so famous that much of the world's traffic still follows the lines traced by the original "Roman Roads." Railways have since largely superseded the roads themselves. Hand in hand with their sister services of wired-telegraphy, they have, until recent years, borne the burden of high speed communications, and revolu-

tionised the face of the earth. Now at the end of 2,000 years electric ethereal waves are taking up this task for civilisation, and Rome once more forms the centre of an important system. The Centocelle Station, located within the precincts of the historic "Seven Hills," radiates the ether waves which bind the Queen-mother of Cities with the great Latin Kingdom to whose intimate and historical connection with herself we have already referred. Nor would it be

of communication between the two countries, but will add immensely to its rapidity in view of the fact that despite all the progress of modern days no *direct* telegraphic communication between the two countries has up to the present existed.

In order to ensure greater efficiency and promptitude the Rome and Spezia Stations have organised a co-partnership in working, and it has been arranged that traffic shall pass at certain fixed hours between Barce-



*Exterior of Wireless Station Building, Prat de Llobregat, Barcelona.*

becoming to ignore the fact that the principal part played in the development of this applied science must be placed to the credit of an Italian, Commendatore Guilelmo Marconi, recently added to the historic ranks of the Roman Senate.

Already, during the short time which has elapsed since the installation of this "wireless link," a large amount of traffic has passed to and fro. The service so rapidly developing cannot fail to prove of inestimable value to business men and others in both countries. It must be noted that the new service will not only generally facilitate the volume

of communication between the two countries, but will add immensely to its rapidity in view of the fact that despite all the progress of modern days no *direct* telegraphic communication between the two countries has up to the present existed.

The ceremony which inaugurated this new development was attended in Rome by the Spanish Ambassador, Señor D. Ramon Piña Y Millet; Señor Almeida, the Secretary of the Spanish Embassy; the high officials of the Ministry of Marine; and the Marquis Luigi Solari, who attended as the representative of Senatore Marconi. In Spain, owing to the distance intervening between the station at Prat de Llobregat and the city of Barcelona, the opening was only per-

sonally attended by the high officials of the Post Office and of the Compañia Nacional De Telegrafia sin Hilos.

Both King Victor Emanuele of Italy and King Alfonso of Spain have entered with individual enthusiasm into the scheme. The establishment of wireless communication between these countries owes much to the zeal of their Majesties for the progress of their peoples, and both monarchs have shown a very active interest in the development of wireless telegraphy. The opening ceremony started most fitly therefore with an interchange of messages of true cordiality between H.M. the King of Spain and H.M. the King of Italy. These messages are worthy of textual reproduction, and we accordingly take the opportunity of recording them here for the benefit of our readers.

To His Majesty the King, Rome.

"At the moment of the opening of this new means of rapid communication which must bind evermore the very cordial relations happily existing between our two countries, I send to your Majesty my most affectionate salutations."

(Signed) ALPHONSE.

To His Majesty the King of Spain, Madrid.

"I thank you infinitely, your Majesty,

"for your kind message which you had the goodness to direct to me on the occasion of the opening of the new radio-telegraphic service. I am happy to see that this new means of communication binds the cordial relations uniting our two countries, and I take with pleasure this occasion to

"renew to your Majesty my most affectionate salutations."  
(Signed)

VITTORIO

EMANUELE.

Following the exchange of these two telegrams, a further message was transmitted by His Excellency the Spanish Ambassador to H.M. the King of Spain, as follows:

"At the inauguration of radio-telegraphic communication I have the honour to offer to your Majesty and the Royal Family my respectful homage and personal adhesion, as well as that of the

"officials acting under me, and of the Spanish colony here; all wishes for the prosperity of the country."

Other telegrams were subsequently transmitted from His Excellency the Spanish Ambassador to the Foreign Office in Spain and to His Excellency the Italian Ambassador in Madrid. Very cordial messages were also received for delivery to His Excellency the Ambassador of Spain in



"Good wine needs no bush." A scene outside a Barcelona inn. Note the vine "bush" hung as a sign outside of what is sold within.

Rome, for Senatore Marconi, and for the Marquis Luigi Solari.

Neither Spanish nor Italian public have been slow in appreciating the facilities which are now open to them. No longer now, as before the opening of the wireless service messages to and from Spain, do messages have to pass over the telegraphic lines of the South of France. These latter, at present overworked in consequence of military exigencies, are relieved of considerable strain, and the rapidity of the new service will not be the least of its advantages.

The message rate has been fixed at 25 centimes (2½d.) per word, and messages can be handed in at any telegraphic office throughout Spain and Italy. Our illustrations depict the exterior of the station building at Barcelona, the disposition of the masts, and a portion of the transmitting plant. Our picture on the opposite page shows the outside of a Spanish posada, with customers sunning themselves on the bench at the doorway. Doubtless, under the vine branches, which still hang in Spain as the sign of an hostelry, they are discussing the passing, thanks to wireless, of *mañana* into *hoy*.

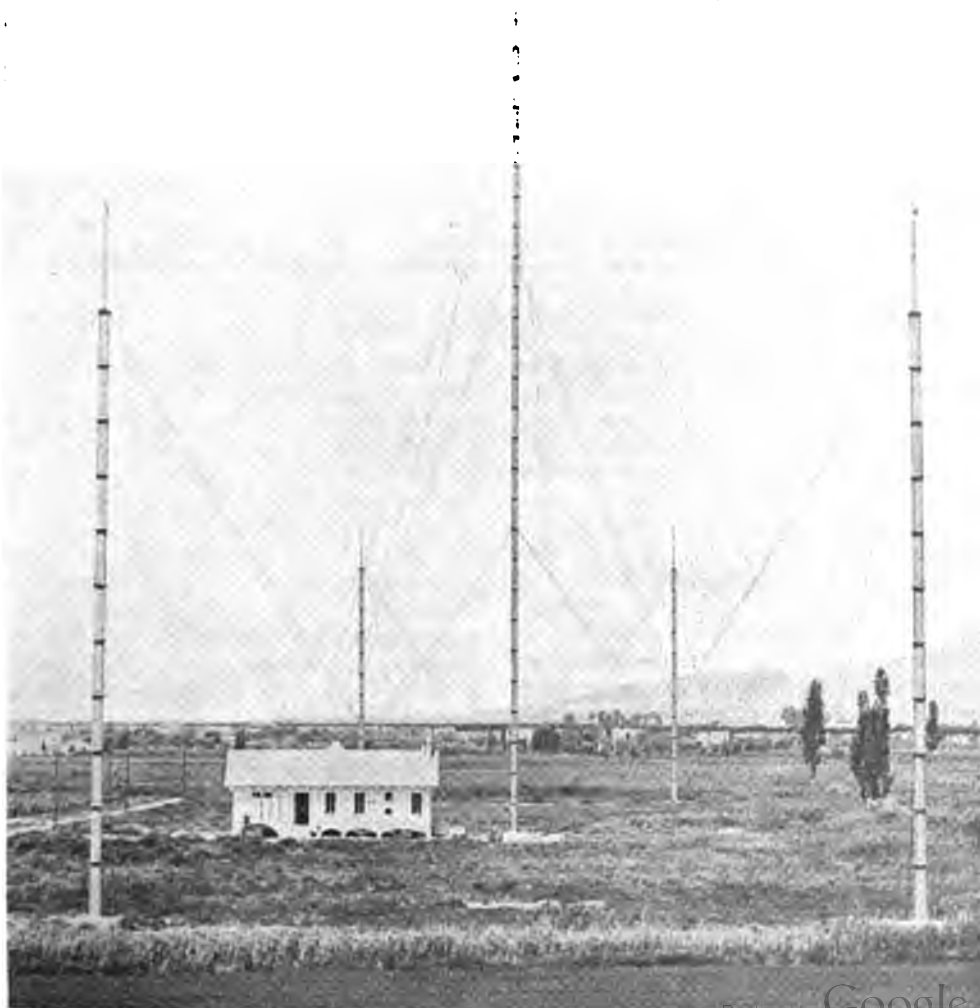

Masts and Station Building, Prat de Llobregat.

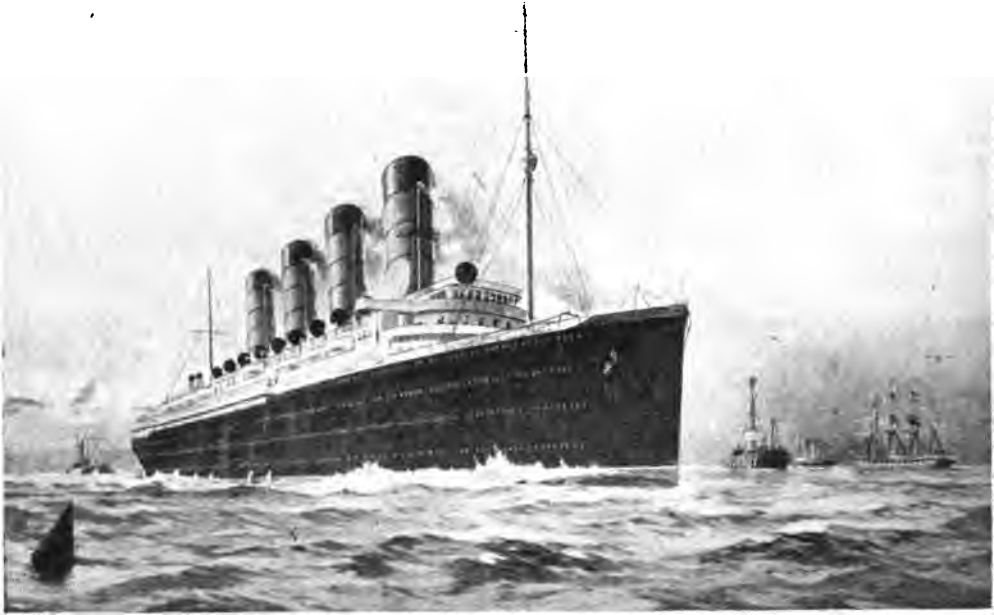

## The Crime of the *Lusitania*

*A Record of the Facts and of the Part Played by Wireless*

**F**EW incidents in this terrible war have attracted more universal attention and reprobation than the sinking of the *Lusitania* by torpedoes from German submarines on May 7th, 1915. When recording in the *Marconigraph* of May, 1912, the heart-rending disaster of the *Titanic*, which aroused world-wide distress, we little thought that in three years' time we should have to record still another, almost as terrible in its loss of life, occasioned, not by the interposition of "the hand of God," but by the machinations of a jealous rival. The popular imagination has been deeply stirred by the destruction of this ocean leviathan, the materialisation of modern ideals of luxury, unarmed, filled with peaceful passengers—hundreds of them of neutral nationality—crossing on private business and pleasure from the New World to the Old. She left New York on May 1st, and, although a so-called "warning" had been issued (a "surprising irregularity," as Mr. Bryan very justly calls it), nothing was further from the minds of passengers than

the imminence of a terrible catastrophe. Twenty-six miles from Queenstown, in the early afternoon of Friday, May 7th, without a word of warning, the vessel was struck by the first torpedo fired. It was soon apparent what had happened, and passengers started making such scanty preparations as were possible in the circumstances. Many of them were in the saloon, in which luncheon had recently been served, and one of the passengers states that having just finished his meal, he went straight to his cabin to fetch his life-jacket. Mounting on deck, he realised the vessel was listing heavily, and two or three minutes later a further tremendous addition to the list was caused, apparently by a second torpedo. From this time it was plain that the ship must go down, and in fact, according to the Captain's evidence at the inquest, she "floated about eighteen minutes after the torpedo struck, and immersion in the sea caused the stoppage of my watch at 2.36½."

On this her last voyage the *Lusitania* carried two wireless operators, their names being Robert Leith and David C. McCormick.

Mr. Leith, who is thirty years of age, and who is a native of Wallasey, was at one time employed as telegraphist on the London and North-Western Railway. He entered the Marconi Company as long ago as 1906, and

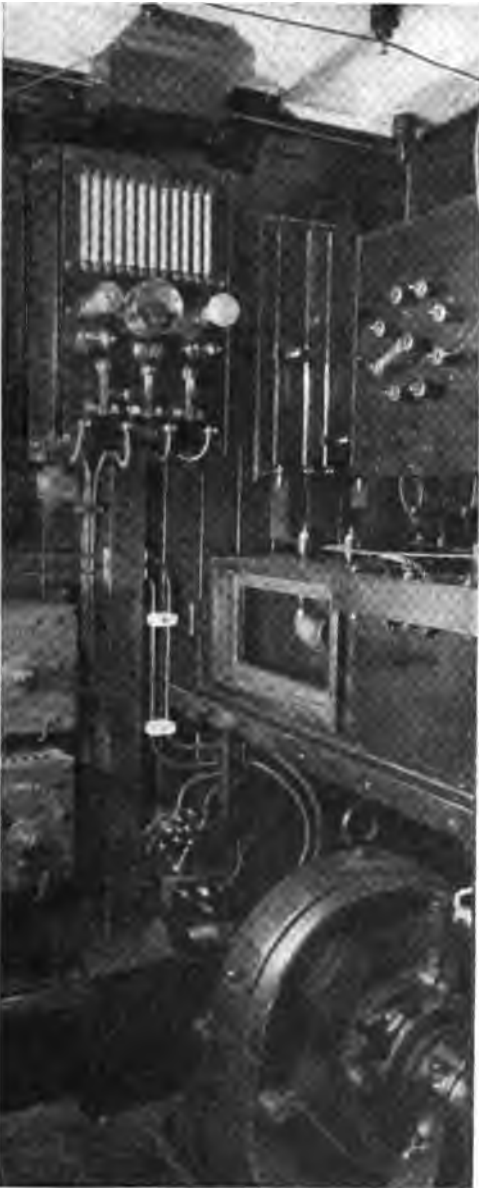

Wireless Transmitter on the "*Lusitania*."

is therefore one of the most senior men of the service. His experience on the North Atlantic has been gained on some of the finest vessels making the crossing, and few men have spent more time on the ships of the Cunard and White Star Lines. Among the crack North Atlantic liners on which Mr. Leith has served as senior wireless operator are the *Aquitania*, *Lusitania*, *Oceanic*, *Celtic*, *Caronia*, *Franconia*, *Adriatic*, and *Baltic*.

The second operator, Mr. D. C. McCormick, whose home is Glasgow, had previous to joining the Marconi Company been engaged in a solicitor's office. He joined the Wireless Service in 1913, and before being appointed to the *Lusitania* had served on board the s.s. *Ionian*, *Colonian*, *Landon Hall*, and *Warwickshire*. He is twenty years of age.

The voyage up to the time when the first impact was felt had been entirely uneventful, and the wireless operators had carried out their duties as usual. Their conduct throughout appears to have been in accordance with what has now become the *Marconi tradition*. They remained at their posts until the last useful moment, and everyone will be glad to hear that they eventually reached shore in safety. Before the sitting of the Board of Trade Enquiry, under the presidency of Lord Mersey, it is impossible to say just what transpired in connection with their duties; but, in answer to enquiries made in the House of Commons, Mr. Churchill, after pointing out that the reserves at the disposal of the Admiralty would not permit them to supply escorts for all merchant or passenger steamers, said that the Admiralty "had a general knowledge that a German warning announcement had been made. From that knowledge, and from other information of submarine movements, we had sent warnings to the *Lusitania* and directions for her course." Supplementary questions asked by Lord Charles Beresford caused the Premier to reiterate the attention given by the Government to German threats; and Mr. Churchill added for the gallant Admiral's benefit that "so far from his warnings being unheeded, a great many of the measures he advocated had already been applied on the largest possible scale." Captain Turner, answering the Coroner's question, stated that, whilst not at liberty to say what the special instructions were that he received,

such instructions did not fail to reach him and were carried out to the best of his ability. He also made the statement that he was "in wireless communication with the shore all the way across."

The senior operator, Mr. Leith, at the time of the impact of the torpedo, was lurching in the saloon, the junior operator being on watch. Mr. Leith tells us that when he came down, a lady on his left remarked that he was late and would not get any lunch. These words of jest came strangely true, for they had hardly been spoken when a dull crashing thud was heard, and it became evident that something serious had happened. Realising that his presence was needed in the wireless cabin, Mr. Leith immediately jumped up from the table and made his way to the upper deck. On arriving in the wireless room he found that his assistant had made everything ready for the distress call to be sent out, and in a moment the famous signal was being made. The SOS call was sent out continually, until it was evident that nothing further could be done; then *and then only* the wireless operators gave a thought to their own safety. Mr. Leith was able to jump some distance into a partially submerged lifeboat which

had been launched, and later transferred to another when it seemed that a funnel was falling on top of the occupants. The aerial wires also fell on the boats and to some extent impeded them.

One incident in Mr. Leith's story deserves particular attention. He states that in the second lifeboat unlaunched to which he transferred the ropes holding the boat to the derricks of the *Lusitania* had not been disconnected. An American passenger, Mr. Collis, by the aid of only a small pocket-knife, managed with considerable difficulty to sever these ropes and thus cut the boat away. Had it not been for this prompt and cool-headed action, the boat with all its occupants would have been dragged down with the sinking liner. Among the many fine deeds which have come to light in connection with the disaster, this certainly deserves a prominent place.

After a considerable time in the water, Mr. Leith was picked up by the fishing-smack *Wanderer*, of Peel, and afterwards taken aboard a paddle-boat which had put out from Queenstown in response to the calls for assistance. It was not before a quarter to ten at night that Mr. Leith was put ashore in Queenstown and was able to rest after his terrible ordeal.



Some of the "Lusitania's" Lifeboats in Queenstown Harbour.



Mr. McCormick, who, as mentioned above, was in the wireless cabin at the time of the



Mr. R. Leith,  
Senior Operator.

explosion of the torpedo, has also told his story. He states that at the moment of the impact of the torpedo he heard a dull heavy thud, and a number of unsecured articles disposed about the wireless cabin came clattering to the floor. The impression gained in these first few moments was that heavy guns were being fired in the immediate neighbourhood. A few minutes later it became apparent that the *Lusitania* had been torpedoed. As soon as it was useless to remain longer in the wireless room, Mr. Leith and his assistant came out on to the boat deck to see what means there were of escape. Mr. McCormick, who was the possessor of a hand camera, crawled along the heavily listing deck and took a photograph of the scene forward, but unfortunately his film was not rolled back, and when the camera came to be immersed in the water the sensitive surface was naturally destroyed. In making



Mr. D. McCormick,  
Junior Operator.

their arrangements for escape there was no attempt at the dramatic, and Mr. McCormick states that Mr. Leith and he did not even say good-bye to one another. Just before leaving the ship the two men lost sight of each other, and did not

again meet until they had been safely landed at Queenstown. Mr. McCormick most emphatically denied that he saw any signs of panic on board, and, although one or two passengers were excited, such conduct seemed to be the exception rather than the rule. His statement in this respect has received noble confirmation from the *sang-froid* displayed by the American millionaire, Mr. Alfred Vanderbilt, who devoted the few moments at his disposal, and that of his man, in a successful endeavour to collect as many children as possible for placing in the boats. By this time the *Lusitania* had listed to a very acute angle; so extreme, in fact, that many members of the crew were able to walk down her starboard side into the sea. After this Mr. McCormick's memories became confused, and nothing but hazy recollections of clinging to a collapsible boat, after escape from the suction caused by the engulfing liner, remain to him until his rescue by a torpedo-boat late in the afternoon.

The famous SOS call naturally played its part in this tragic drama, and some of the papers have reproduced the dots and dashes which go to make up the signal. We are sorry to notice, however, that in some cases the old illusion with regard to its meaning is also reproduced. It is perhaps hardly necessary to remind readers of THE WIRELESS WORLD that the signal was chosen without regard to any significance which might be attached to the individual letters SOS. The three dots, three dashes, and three dots which constitute the distress call are not transmitted as indicating the initial letters of any dramatic sentence (such as "Save our souls," "Send out succour," etc.), but simply make up a rhythmic call which is distinctive from other signals used in wireless telegraphy.

Such are the sober facts of the case; but imagination is allowed to play round mere "Fact" and often goes more nearly to the "heart of things" than do the prosaic realities. Although the great liner now lies beneath the waves, her engines stilled for ever, her dynamos at rest, and her emergency apparatus out of action, she still continues to send her message to the world. SOS may not inaptly be interpreted "Send Out Soldiers," soldiers of righteousness, to crush the infamous Huns whose foul deed cries aloud for vengeance.

# Wireless Telegraphy in the War

*A résumé of the work which is being accomplished both on land and sea.*

WE have had occasion in these columns recently to make several references to *German wireless lies*. Our remarks have been directed towards disabusing our readers of any implication contained in the linking of *wireless* with *lying*. Our German enemies have simply made use of a medium of communication which the present war has proved to be the most reliable from the point of view of any interruption. That they have abused it is only what is to be expected of them. Our daily contemporary, the *Express*, has on several occasions recently pointed out that despite the unreliability of the German messages through the tainted nature of their source, the excellence of their medium has resulted in their reaching the columns of the Press in advance of our own announcements.

The *Express* has catalogued quite a series of important events thus announced by wireless ahead of its rivals. In this catalogue figure the British gain of Hill 60, where wireless news was twenty-four hours ahead; the crossing of the Yser and the capture of Lizerne, where it anticipated news from other sources by twenty-four and six hours respectively. In the case of the blockade of the Cameroon coast wireless sources announced it on the 25th April, whilst it did not appear in London until the *London Gazette* notified it on April 27th. These are only a few of the more recent instances which go to show the promptitude of transmission and suitability of the medium for rapid dispatch.

Our German opponents, who are responsible for popularity of the phrase, *wireless lies*, have added to the "gaiety of nations" recently by a very amusing case in point. Their official wireless intelligence detailed the statement that the submarine *U 29*, which was recently sunk, was engaged at the time in rescue work. This Teutonic explanation sounds more than a little far-

fetched. There has been no single instance during this struggle of any German war vessel engaging in rescue work, whilst, on the other hand, there have been many instances of the destruction by such vessels of the lives of helpless non-combatants and even of unsuspecting neutrals. Besides, how came the German Government to know the details of how the *U29* was sunk? None of the crew returned to tell the tale, and nobody else would be likely to carry the news to Berlin. It is, therefore, very apparent that the controllers of the German wireless do not make a practice of waiting for authentic information, but in default thereof extract their news from their own fertile imaginations.

An interesting variation in the use of ship's wireless is narrated by Captain W. J. King, of the Aberdeen barque *Invercor*, which was sunk by the *Eitel Friedrich*, off the Brazilian coast. The information appears to have been given to a newspaper reporter at Newport News, U.S.A., after the internment of the German cruiser. Captain King says:—

"Do you know what they did with their wireless? They rigged up an eight-foot kite, used the thinly-drawn wire of Lord Thompson's sounding machine, made that fast to the kite and attached it to the wireless receiver. Then every night they would send up this kite and catch every bit of wireless that was going. Their wireless could send only 900 miles, but by the use of this kite arrangement they could hear up to 2,500 miles. The wireless news that was picked up in this way was written out in German and put on a bulletin board. In that way we heard all about the forcing of the Dardanelles, the fire on board the *Touraine* and other current news. These kites had to be flown against the wind, and on sending them up the course of the ship had to be altered so as to bring the wind ahead. They lost sixteen of these kites while I was on board, due to the wind



"Ophelia" Trial.—Sir S. Evans (President) is examining a Chart, whilst Dr. Pfeiffer (Commander of "Ophelia") stands in the Witness Box.

"suddenly shifting and the kites tumbling down into the water. But they had material enough on board to make as many more as they wanted."

We must decline to vouch in any way for the accuracy of Captain King's statements and figures; but give his account "for what it is worth"!

\* \* \*

The evidence in the case of the German hospital ship *Ophelia*, the "Mystery Ship," as some of the newspapers call her, deserves careful reading *in extenso*. The evidence of Lieutenant F. T. Peters, R.N., of H.M.S. *Meteor*, indicates that the circumstances attending the destruction of the more important wireless log was considered sufficiently suspicious to instruct him to dismantle the radio-telegraphy apparatus, and order the *Ophelia* to follow H.M.S. *Meteor*. Mr. J. A. Cox, the leading telegraphist in H.M.S. *Lawford* indicated the way in which skilled operators are able to judge the distance of a station whose calls are being received by them. He "heard a loud signal in code on the 300-metre wave and judged it must have been transmitted from a ship not more than ten miles distant." It was answered from

"KA.V.," which he knew to be the call sign of the Norddeich station. The plea advanced by the captain of the *Ophelia* that only two communications had been received by wireless—one in code and one open—would appear to be inconsistent with the fact that on October 10th the vessel made a special stay of ten days at Hamburg for the purpose of allowing her masts to be lengthened so as to improve her wireless range. The Germans do not usually spend time and money in improving installations which are not intended to be used. The only wireless log which was seized by the British had been kept on loose sheets, and contained no entries except Press reports. The conclusion is inevitable that the other wireless log, thrown overboard with her papers, contained all entries of importance.

\* \* \*

Some interesting evidence was given by the *Ophelia's* wireless operator, a man named Grau, who stated (in contradiction of the evidence of Dr. Pfeiffer) that he sent several wireless messages while the ship was at Kiel. Naturally he professed that they were harmless, and merely concerned the ship's equipment; but the admission was in itself significant. Grau stated that, on the voyage



S.S. "Kronprinz Wilhelm," now interned in the United States.

from the Canal to Heligoland, no wireless messages were received, although he acknowledged having taken messages from the *Wurtemberg*, which he called "the head hospital ship." The same witness stated that there was a secret wireless code for the German Imperial Navy, and a separate secret code for auxiliary and non-combatant ships. According to his evidence, the warships were put in possession of both codes,

but non-combatants did not receive that of the Imperial Navy. On being pressed by the President of the Court with regard to the codes he had been in the habit of using, he shuffled considerably, and finally took refuge in a plea of ignorance.

\* \* \*

The British Press have been announcing recently that the Germans have secretly trebled the strength of their wireless plant



"Prinz Eitel Friedrich" at Newport News.

at Sayville, Long Island, U.S.A. The enemy would appear to hope that the erection of three 500 ft. towers there will secure them a continuous service between America and Germany under all static conditions. It would seem that one of the chief complaints made by the captains of the *Prinz Eitel Friedrich* and the *Kronprinz Wilhelm* has been the difficulty encountered by them in securing instructions from the German Admiralty owing to the irregularity of the wireless service.

Those genial tergiversators of the truth, Count Bernstorff and Herr Dernburg, also complain of having been handicapped in the "diplomatic work" of presenting their courteously framed official messages to the United States. There is hope, however, for the Americans yet; for should this wireless plant, manufactured in Germany and transported to the States by the Holland-America Line, prove successful, no doubt they will have ample opportunity of learning their duties to humanity by the official teachings of the "Apostles of Kultur." Sayville appears to be a somewhat out-of-the-way spot, so that the people in the neighbourhood generally seem quite unaware of the arrangements being made to transform the station. Doubtless President Wilson and his colleagues are well aware of their obligations with regard to neutrality, but at first glance such proceedings would appear to be somewhat straining the rights of belligerents in a neutral country.

\* \* \*

One of our daily contemporaries recently published a long account of a visit by its accredited correspondent to the British armies in the field. We cull the following extract from his report:—

"I saw romance of the very latest type—more wonderful in many ways than that of Perseus and the Greek heroes—in a field of France not far from where I write. Outwardly there was not much to see—a tall, bare pole attached to earth by wires, with a wooden hut beside it. But that pole had more magic in it than a wizard's rod, and the wooden hut was a receiving house of astounding secrets. Here was a wireless station and while I stood there the officer in charge brought out a flimsy piece of paper on which had been recorded the



*Effect of Shell-fire on Trenches at the Front.*

"latest messages gathered in from the vibrating waves of air which had come whispering to the wires of the tall pole. They were the official bulletins of war issued by the enemy and intended for publication on our side of the front. A little while later in the day the receiving instrument in a wooden hut would record messages sent by 'wireless' from British aeroplanes flying on reconnaissance over German lines."

\* \* \*

In connection with the *Falaba* outrage, we learn from the New York correspondent of a London paper that the pirate in charge of the operation was Commander Schmidt, of the German submarine *U 28*.

# INSTRUCTION IN WIRELESS TELEGRAPHY

(Second Course)

## (XI.) The Receiving Circuit.

[The dislocation of our arrangements, due to the war, has prevented us from competing, in our last Volume, the second course of Instructional Articles. These are being continued in the third Volume, and we hope to arrange for the Examination (full particulars of which are given on page 333 of our issue of August, 1914) to be held in the early autumn of this year. The present is the tenth of the second series of articles, which will deal chiefly with the application of the principles of wireless telegraphy. Those who have not studied the first series are advised to obtain a copy of *The Elementary Principles of Wireless Telegraphy*, which is now published, price one shilling net, and to master its contents before taking up the second course of instruction.]

**763. The Detector.**—At the present time by far the larger number of detectors in use are of the type usually termed “crystals,” and these will, therefore, be treated first.

The term “crystal” is a convenient one to use, but it is to be noted that not all crystals are suitable as detectors, and the value of any particular type of crystal depends rather on other qualities than its crystalline form. A more general term is “contact detector,” which, however, includes the various forms of coherers.

**764.** Most of the crystals in use are native minerals, such as zincite, galena, etc., used in the state in which they are found without any chemical or other treatment; one or two are chemical elements, more or less pure, as silicon and tellurium; and some are manufactured products, such as carborundum.

**765.** The action of a crystal as a detector of wireless signals is fully explained in the instructional articles in the December, 1913, and January, 1914, numbers of THE WIRELESS WORLD.

In these it is shown that this action depends on two properties of the crystal.

(1) If a potential be applied to a crystal, the current in one direction is many times that given when the sign of the applied potential is reversed.

(2) The current is not directly proportional to the applied potential, as it is for an ordinary metallic resistance, but the ratio between them varies with the value of the potential.

The actual detector consists of the crystal and whatever is used to make contact with it, which may be a metallic surface or point or another crystal.

**766.** If a curve be plotted showing the relationship between the current flowing through any material and the applied potential, this curve is termed the characteristic curve of the material.

Metallic conductors and other materials of which the resistance does not depend on the current-density, or which, as it is termed, “obey Ohm’s Law,” have a straight line for their characteristic curve, but crystals and other contact detectors give characteristic curves of varied forms.

**767.** The theory of the action of a crystal has not yet been fully worked out. The subject presents some difficulties, since it is probable that for many crystals the rectifying property on which their use as detectors depends is due partly to impurities which are present in the mass of the substance and also to the state of the surface at the point of contact—i.e., whether it is covered by a thin film of oxide, sulphide or other compound differing from the composition of the bulk of the specimen.

It has been pointed out also that a proper study of the action must be made using currents of the strength met with in actual practice, which, as is known, are very small and not so easy to measure as larger ones would be. Hence the conclusions reached by some observers cannot always be held to apply to the actual conditions under which the crystals are used as detectors owing to the large currents used by them. Moreover, for many substances it is difficult to keep the sensitivity constant for any length of time.

**768.** Dr. W. H. Eccles has done a large amount of work on this subject, both experimental and theoretical.

In a paper published in the Proceedings of the Physical Society of London, Vol. XXV., and abstracted in the *Electrician* for September 5th, 1913, and THE WIRELESS WORLD for July, 1913, he has put forward a theory of the action of contact detectors in general. The theory has the merit of

769. Dr. Eccles shows that the various electrical and thermal phenomena which occur when a current passes across the contact between two conductors can be represented by the terms of an equation, and the various forms of the general equation, for different relationships between the terms,

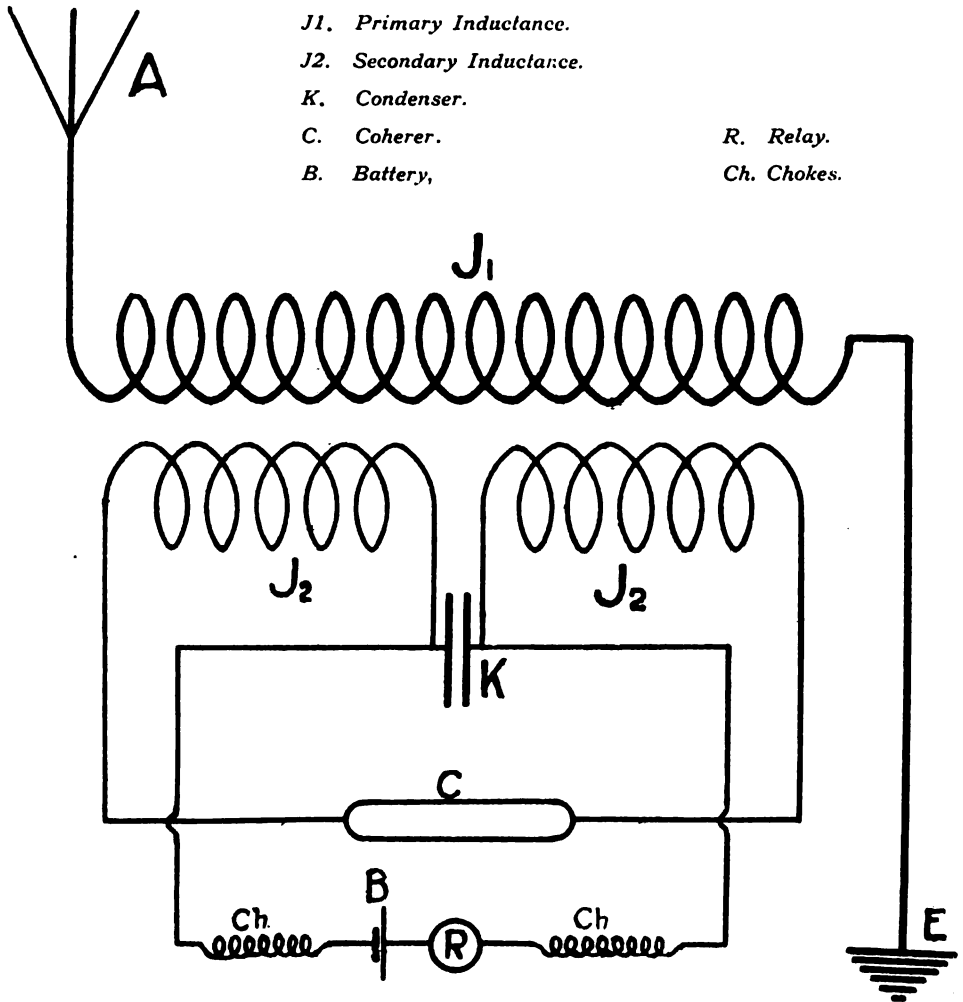

- J1. Primary Inductance.
- J2. Secondary Inductance.
- K. Condenser.
- C. Coherer.
- B. Battery,

- R. Relay.
- Ch. Chokes.

dealing with effects which are well known instead of phenomena which have only been partly investigated. A short account of this theory will be of use, not only because it appears to be accepted by a number of physicists, but because it gives an idea of the various methods which might be adopted to attempt to increase the sensitivity of some particular detector.

give curves similar to the various classes of characteristics given by detectors.

770. The chief physical effects which occur when a current flows across the junction of two bodies, A and B, are as follows:—

(i.) Heat is generated or absorbed in accordance with the law of Peltier.

The Peltier effect is as follows: When a

current flows in a circuit which includes conductors of different materials—*e.g.*, antimony and bismuth, then at the junctions of these two materials heat is liberated or absorbed from the surroundings, and its amount depends on the nature of the two materials. If heat is developed at a junction with the current flowing in one direction, as from antimony to bismuth, then the same quantity of heat will be absorbed when the current flows from bismuth to antimony.

**771.** (ii.) Heat is developed according to Joule's law.

If the two materials, A and B, are poor conductors of heat and electricity (which is usually the case for detectors), then not only will the amount of heat be relatively large (due to the high resistance), but it, together with any developed by the Peltier effect, will not be dissipated by conduction, but will cause a rise in the temperature of the junction and a local heating will take place.

**772.** (iii.) It is well known that the resistance of all metallic conductors changes with the temperature, becoming higher for higher temperatures.

The resistance of the materials we are considering also changes with the temperature, but the coefficient of change of resistance is often very large. For many substances the resistance decreases with increase of temperature. Due to this cause, the resistance is seen to depend on the magnitude of the current flowing.

**773.** For bad conductors of heat the temperature gradient at points near the junction will be steep—*i.e.*, the temperature will vary rapidly at points near the contact.

It has been shown by Lord Kelvin that when a current flows from a colder to a hotter part of a conductor, or *vice versa*, a transfer of heat takes place. In some materials the transfer increases the temperature-difference when the current flows from the colder to the hotter part of the circuit, and in other materials the reverse holds. When the current is reversed, the direction of transfer is reversed. Due to this, the temperature gradient will not be that due alone to the conductivity for heat of the materials, but will depend on the current flowing, since the heat transfer is proportional to this current. When the transfer is such as to increase the temperature at the

junction, those effects which depend on this temperature will be enhanced.

**774.** In his paper Dr. Eccles states that the thermo-electric properties of substances like pyrites, zincite, etc., are difficult to measure accurately, as also are the coefficients of change of resistance with temperature, but, from measurements made, he finds that they are usually larger than for metallic conductors. The temperature resistance coefficients are large and negative for the substances examined.

It is to be noted that the change of resistance with temperature is sufficient by itself to account for all the principal features of the action of the single point coherer (which is a special form of contact detector). A paper by Dr. Eccles on this subject is to be found in the Proceedings of the Physical Society, Vol. XXII., page 869, and *Electrician*, August 12th and 19th, 1910.

**775.** In addition to the above, various other effects have been brought forward to explain the action of this class of detectors, and probably the complete theory would find place for all these effects.

One theory is as follows: If two conducting bodies are placed very close together, without actual contact, and have a difference of potential established between them, then they will attract each other electrostatically, and if they are separated by an extremely minute distance the force of attraction may be very large, even though the charging voltage is small. It is evident that this large force may modify the conditions at the junction and might influence the passage of the electrons to which the current is due over the interface. If the two conductors were separated by a film of, say, oxide, the resistance at the contact might by this means be varied over a wide range.

**776.** It will be readily understood that by applying an independent potential to the detector the sensitivity can be increased in many cases, since the various effects enumerated above depend on the magnitude of the current flowing, and a certain value of steady current will give a maximum amount of rectified current, due to the applied high-frequency potential.

Moreover, since the effects are essentially local round the contact, the pressure between the two bodies and the area over which they are in contact has a great



influence on the sensitivity. Many substances require a very light contact with a fine wire for best results, and, due to this, are often very variable in action, since the slightest mechanical vibration alters the pressure and modifies the current-flow at the junction.

The pressure not only modifies the area in contact, but also might alter the thickness of some surface layer at the interface. Some experimenters have noticed that immersing a particular detector in oil or other liquid improves the sensitivity, which is probably due to the alteration in the temperature effects.

The rectifying properties of many detectors are localised in spots on the surface and not general over it, and in practically every case considerable variation in sensitivity occurs in different specimens from the same mass.

The majority of crystals are injured by heating, and for this reason it is usual, when it is required to set them in cups, to use low-melting fusible alloy. The object of setting the detectors in cups is to reduce the resistance of that part which is not concerned in the rectification and to provide a convenient means of fixing in the adjustable crystal clips which are used.

Some crystals, such as carborundum, will stand being mounted with ordinary solder.

It is possible to increase the sensitivity of certain detectors; thus, in an article on "Characteristics of Crystal Rectification," in the December 11th, 1914, number of the *Electrician*, Mr. Flowers mentions that by treatment with hot sulphur sensitive spots can be made on galena crystals.

There is room for much experimental work in connection with crystal detectors before a complete explanation is available. The work is difficult, owing to the fact that for many of them the sensitive portions occur in small spots and not throughout the crystal, and it is difficult to determine the difference, between these spots and the surrounding material, to which the sensitivity is due. Those who are interested will find a list of papers on the subject in a paper by Mr. P. R. Coursey, Proceedings of the Physical Society, Vol. XXVI.

The usefulness of any particular substance as a detector can only be ascertained after a trial with several samples over some time, since this largely depends on a balance

between the sensitivity and reliability for different conditions.

**777. The Coherer.**—It is not proposed to give a complete account of all kinds of detectors here, but only of those of general interest to those for whom these columns are more particularly intended. Although for practical wireless telegraphy the coherer is obsolete, yet it still finds employment for particular purposes, such as the fog-signalling apparatus described in the June, 1914, number of *THE WIRELESS WORLD*.

The property of a coherer which renders it useful for this purpose is this, that whilst most other forms of detector act by converting part of the electromagnetic energy received by the aerial into useful signals, in the coherer this energy is not directly so used, but employed to put the detector into such a condition that a current can be sent through a circuit from a local battery. The strength of this current can be adjusted by suitable means, and it can be used to actuate mechanisms, such as the relay which works the balance-wheel of the fog-signalling apparatus mentioned above, or the ordinary Morse Inker.

Although the coherer itself is less sensitive than the ordinary crystal detectors, yet, given sufficient energy in the aerial, it is better adapted to work a relay than they are. Hence the use made of it for the distant control of apparatus.

**778.** In paragraph 768 above mention was made of a paper by Dr. Eccles in which an hypothesis of coherer-action is put forward with special reference to the form consisting of an oxidised steel point dipping in mercury.

This is briefly as follows: When a train of high-frequency oscillations passes through the surface between the two masses which constitute the coherer, the minute film of oxide at the junction is heated and its electrical resistance is lowered. The lowering of the resistance allows a larger current to flow, the equilibrium of the direct current from the local battery being disturbed.

Dr. Eccles has shown that the equations which express the above facts give rise to curves which follow those actually obtained from coherers.

There are one or two forms of coherer for which the theory is not exactly suitable.

Thus, in the Lodge-Muirhead-Robinson

form, in which a greasy steel wheel revolves in contact with a globule of mercury, it is the breaking-down of the film of oil by the signals to which the action is due. Coherers are of two forms, those which after the passage of a signal require to be brought back to a sensitive state and those which do not. The usual method for rendering the first class sensitive is to provide a tapper, which may be similar to an ordinary electric bell. This can be arranged to work off an independent battery, in which case it is always in action, whether signals are coming or not, or a far better method is to wind the coils so that they can be actuated by the same current, from the relay associated with the circuit, as is used to work the apparatus. In this case the tapper only works when signals are received.

The coherer is an instrument which requires great care in making in order to obtain it sensitive and reliable. The usual form consists of a small quantity of metallic filings enclosed between two metallic plugs in a glass tube which is exhausted. In the Marconi pattern a mixture of iron and nickel filings is used.

Various other forms are described in *The Principles of Electric Wave Telegraphy and Telephony* by Prof. J. A. Fleming.

The circuits used for the coherer are slightly different from those for other detectors. The secondary coil is wound in two equal parts on one former with a space between them. To the inner ends a condenser is connected and to the outer ends the coherer. The rest of the apparatus is connected as shown in the diagram.

## Wire-cutting Device for Aeroplanes.

**A**EROPLANES fitted with wireless apparatus carry a long length of wire, which trails beneath the machine for the purpose of picking up messages from below when the machine is in flight. In case of a hasty landing

the winding spool through the cutter, the interior edges of which are as sharp as a razor blade. In case of emergency all the aviator has to do is to press down the lever, which is placed conveniently for his right hand, and the cut wire falls away.

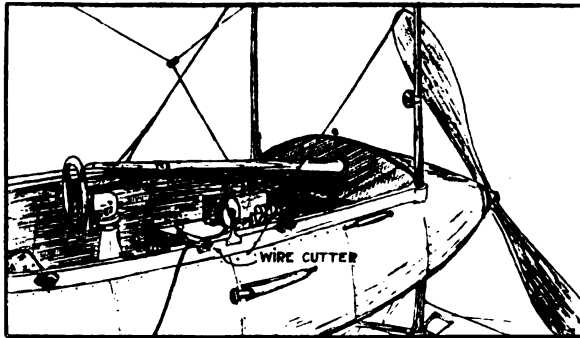

*Enlarged view of Wire-cutter.*

this wire is liable to become entangled with the landing chassis, with trees or other objects, and cause a serious accident.

To prevent such mishaps an ingenious device is attached to the machine in the shape of a wire-cutter, which is so placed that the pressure of a lever severs the wire hanging from the aeroplane. Our illustration below shows a machine with this useful device attached. It is V-shaped, with a hinge at the apex. The cable passes from

### TIT FOR TAT.

The following dialogue is reported to have occurred between French and German wireless stations at the beginning of the war:—

German Operator: "Where are you? Have you had a good sleep?"

French Operator: "Fine here. We slept at Metz."

German Operator: "Oh! Well, tomorrow we shall be in Paris!"

French Operator: "Yes, but as prisoners." No reply from German station.

# Television

*When shall we see as well as hear by Wireless ?*

SOME NOTES BY MR. MARCUS J. MARTIN.

*Our well-known weekly contemporary "Answers," in an issue published towards the beginning of May, includes a short article under the heading of "Shall we See by Wireless?" The remarks contained therein cover some points which are doubtless familiar to readers of "The Wireless World" through the series of articles which appeared in volume 2 under the title of "Radio-photography," by Marcus J. Martin. These are being supplemented in volume 3 in a series by the same writer, entitled "The Wireless Transmission of Photographs," dealing further with the subject. The following notes have been especially written by Mr. Martin for us, and will serve to indicate the position in which the development of the televisionary branch of the subject stands at the present moment.*

**A**LTHOUGH many attempts have been made during recent years to solve the fascinating problem of "television," there has been up to the present no system that can claim to be in any way practicable. Experiments have been made in which fair results have been obtained, but as far as the writer is aware these have never passed beyond the laboratory stage. There have been several systems devised that are workable, but to employ them for practical purposes is out of the question on account of the enormous expense entailed. One of the simplest and at the same time one of the oldest systems employs at the transmitting station a screen composed of a mosaic of small selenium cells. These cells are all connected separately at the receiving station with a battery and a small electric lamp, the lamps being arranged in similar order to the mosaic of selenium cells. If a simple picture in monotone be thrown upon the mosaic of selenium cells, the resistance of those cells that are under the influence of the light parts of the picture is reduced, and sufficient current flows through the line to light the corresponding lamp at the receiving station. A picture, constant as long as the cells are under the influence of the original picture, is thus obtained on the receiving screen.

According to some calculations made by Mr. Shelford Bidwell, the cost of receiving a picture 2 in. by 2 in., with a grain as fine as an ordinary newspaper illustration, over a distance of 100 miles, would be *one and a quarter million pounds*, and necessitate the employment of at least 40,000 selenium cells.

Many modifications of this method have been devised, the most recent employing only three line wires and a common earth; but, except for the system briefly described above, all television systems depend for their action upon what is known as the "persistence" of vision, the whole process of building up the secondary picture occupying a space of time not more than one-tenth of a second—the *duration of the persistence of vision*.

There is no doubt that in the near future we may have some practical system of television to work over ordinary conductors; the idea of wireless television is, from a really practical point of view, absurdly improbable. The fact that wireless photography and wireless telephony are experimentally accomplished facts in no way proves that wireless television is feasible. The principles involved are entirely different. In telephony the vibrations which affect the ear, causing different sounds, consist of a number of impulses which impinge in very rapid succession on practically one spot on the telephone diaphragm; and while in television we also require a large number of impulses delivered in very rapid succession, or simultaneously, the impulses must also be arranged in proper sequence in order to reproduce correctly the transmitted picture. To construct wireless apparatus capable of transmitting and receiving 40,000 signals in one-tenth of a second, and arrange them in their correct order, would surely tax to the utmost the powers of our cleverest inventors, and prove the limit of even human ingenuity.

# Among the Wireless Societies

## *Notes on Meetings and Future Arrangements.*

**Wireless Society of London.**—At the meeting of the Wireless Society of London on Tuesday, April 20th, Prof. E. W. Marchant gave a lecture in which he described the various methods of measuring the strength of wireless signals. The lecture overlapped, to a certain extent, Prof. Marchant's Paper before the Institution of Electrical Engineers, but a special appeal was made to wireless operators professional or amateur, to pay greater attention to the accurate measurement of wireless signals. The importance of it, said Prof. Marchant, is now generally recognised. The quantitative results obtained by Duddell and Taylor, ten years ago, were the first attempt to make accurate measurements of wireless signals. As a matter of historical record, it may be said that these were carried out in Bushey Park, and were, naturally, over quite small distances. The equation which was arrived at from these experiments is now generally accepted as the one which represents approximately the current received under any given conditions and with a given height of aerial. Reference was then made to subsequent theoretical work and the establishment of the Austin formula, which gives the approximate value for finding the order of the magnitude which has to be measured. It was well known, said the lecturer, that the values undergo large and constant fluctuations, and that the equation is only useful for giving us the order of the magnitude of the values involved. The importance of the subject lies in finding out the extent of the variations.

Before attempting to make any experiments on the strength of received wireless signals, continued Prof. Marchant, it is necessary, as far as possible, to have constant conditions at the receiving station. The aerial should be of a standard form and free, as far as possible, from surrounding obstacles, such as trees and houses. This condition was absolutely necessary when absolute measurements are to be made. A second factor was the resistance between the aerial and earth. In order to get good results, the earth

resistance should be as constant as possible. The ordinary form of earth-plate lightning conductor—viz., plate copper and coke, was excellent. At Liverpool he had used a water-pipe system as earth with satisfactory results. He had recently excavated a trench 25 yards long, and used plate copper, 6 feet square, connected with copper strip at the aerial end. The point to be borne in mind was that the strip and earth should extend over as large an area as possible. He had also driven twelve 2-inch cast-iron pipes into the ground. An interesting fact discovered in connection with this work was the amount of moisture in the sandstone which had been covered for ten years with a layer of impervious concrete, this amounting to about 10 per cent. It was a remarkable result, as he had expected to find a fairly dry earth, but the contrary was actually the case, and he had great hopes that the earth which would be obtained by sinking wires in this sandstone would be quite an effective one. At Liverpool the antenna was 150 feet high, with a horizontal span of 500 feet. It was not a very good earth because the ran-over ground there was covered with buildings. Nevertheless, the results obtained gave a fair measure of the variations in the strength of the signals. The best method was to use an instrument which would read actual current or voltage on the antenna circuit. Prof. Howes had used an ammeter to measure signals from Paris of extremely small powers, the Duddell thermo-ammeter was the most sensitive alternating current instrument. The elimination of atmospherics was one of the greatest difficulties. Very frequently in the summer, even in Liverpool, it was necessary to have a conducting leak from the aerial to the earth, and for this purpose he had adopted the Marconi standard method. He had found a choking coil with ten ohms resistance satisfactory, and its connection or disconnection had no appreciable effect. The Fleming valve was not found satisfactory, although at one time he had had great hopes of it. The great virtue of it was that there was nothing to go wrong. If one got an atmospheric the valve

was not burned out. It was quite good to use again, but the results of his experiments with the Fleming valve had convinced him that it was very little good for accurate measurement as its sensitiveness was rather irregular. Various other detectors were described by the lecturer, who added that electrolytic and magnetic detectors were capable of good work. The latter, however, was not sufficiently sensitive for measuring weak signals. Similarly, although he had not had much experience of electrolytic detectors, he would not expect to find this type very reliable. In the Marconi form of magnetic detector certain modifications were necessary to make it completely reliable for accurate investigations. The shunted telephone method had been used, but there was no comparison between that and a galvanometer for measuring signal strength. A novel form of telephone condenser or static telephone had received some attention lately. As to galvanometers, the Broca was satisfactory when conditions were good, but when atmospherics were bad the galvanometer was not of much value. The best arrangement was a very high frequency or short-period galvanometer used in conjunction with a crystal detector.

A short discussion followed, in which Mr. P. R. Coursey, Dr. Erskine Murray and Mr. W. Duddell took part. Mr. Coursey, who has worked with Dr. Fleming, whose experiments were described in the discussion on Prof. Marchant's Institution paper, expressed the opinion that better results might have been obtained if they had coupled the antenna on to the circuit. As to the Fleming valve, they had one at University College, which gave maximum sensitiveness almost at zero voltage. Dr. Erskine Murray said that, in spite of the discussion on Prof. Marchant's Paper, no one seemed yet to have put the whole problem of the variations in transmission in a nutshell. Everyone seemed to attack it from different points. Mr. W. Duddell said he had endeavoured to interest as many people as he could in this question of measurement. He had been three times to Brussels in an endeavour to get the nations of the world to make international measurements, but the war stopped the first co-ordinated measurements of this nature during the eclipse. Even now, however, when all stations were shut down, there was

still a lot of work that could be done in trying to develop instruments which would accurately measure an oscillating current either in the aerial or in a circuit coupled to it.

\* \* \*

**Barnsley Amateur Wireless Association.**—The Barnsley Amateur Wireless Association, like most of the amateur societies, has had to restrict its activities owing to the war, but the classes for the Study of Wireless and Morse Practice are still continued regularly. Two of the members have enlisted as electricians in the Mechanical Transport Service, where no doubt the information they have gleaned at the society's meetings will be of value to them. The society's headquarters are at the Y.M.C.A., Eldon Street, Barnsley.

\* \* \*

**British Association Meetings.**—The British Association will hold meetings at Manchester from September 7th to 11th next, under the presidency of Professor Arthur Schuster. The Presidents of sections will be: Mathematics and Physics, Sir F. W. Dyson; Chemistry, Professor H. B. Baker; Geology, Professor Grenville Cole; Zoology, Professor E. A. Minchin; Geography, Capt. H. G. Lyons; Economics, Dr. W. R. Scott; Engineering, Dr. H. S. Hele-Shaw; Anthropology, Dr. C. G. Seligman; Physiology, Professor W. M. Bayliss; Botany, Professor W. H. Lang; Education, Mrs. Henry Sidgwick; Agriculture, Mr. R. H. Rew. Evening addresses will be delivered by Mr. H. W. T. Wager on "The Behaviour of Plants in Response to Light," and by Dr. R. A. Sampson, Astronomer-Royal for Scotland.

\* \* \*

**Halifax and District Amateur Wireless Association.**—The annual meeting of the above Society was held on Friday, May 7th, at the Club headquarters. A report of the year's work was read by the Secretary, and the Treasurer's report showed that the Club was in a good financial position. Meetings will be held weekly and the usual course of instruction will be continued. A series of lectures are to be given during the coming session, which it is hoped will prove both interesting and instructive. Any further information may be obtained from the Secretary, Mr. A. Holdsworth, 3, Kliffen Place, Halifax.

# The LIBRARY TABLE



“THE YEAR-BOOK OF WIRELESS TELEGRAPHY AND TELEPHONY.” (*Wireless Press*, 3s. 6d.)

The *Year-Book of Wireless Telegraphy* has so firmly established itself as a standard work of reference on all that pertains to radio-telegraphy and telephony that the publication of the 1915 issue will be welcomed by everyone interested in wireless. During the twelve months that have elapsed since the last issue appeared immense progress has been made in the extension and development of this form of communication, and the present volume contains considerable additions and alterations, bringing it well up-to-date. In addition to its being an invaluable book of reference, it also includes a complete historical *résumé* of the development of etheric wave telegraphy from its inception to the present day.

Regarding the main features of the book, we first find a carefully compiled calendar, which is succeeded by the exhaustive chronological account of the progress of wireless telegraphy. The “Chronicle,” set out in diary form, shows at a glance what inventions and improvements were introduced in any particular year. Immediately next in order follows the full text of the International Radio-telegraphic Convention—a valuable contribution embodying the concerted policy of every Government in relation to wireless telegraphy. In close relationship with this international section, “The Safety of Life at Sea Convention” will be found here set out practically *in*

*extenso*. Those familiar with its provisions need scarcely be reminded that this ordinance forms a striking demonstration of the prominent part played in life-saving by radio-telegraphy. Following on this text comes that of the laws and regulations applied by various countries to the control of wireless telegraphy, both with regard to land and ship stations. Another valuable feature consists of a complete list of all ship and shore wireless stations, together with their call signals. This section alone renders a copy of the *Year-Book* indispensable for the shelves containing books of reference in every office. Not only does it show at a glance what ships are fitted with radio-telegraphic apparatus, but also the various coast stations through which one can establish communication with them. An excellent map of the wireless stations of the world completes the information on these points. Ready reference is facilitated by the further addition of an alphabetical list of call letters. Over and above the tabulated information, which forms such a valuable feature of the book, there figures in its pages a most interesting series of articles contributed by eminent experts and scientists, each writing on his own special subject.

Mr. Archibald Hurd, the well-known naval critic of the *Daily Telegraph*, contributes an article on “Wireless and War at Sea,” and Colonel F. N. Maude, the celebrated writer on military subjects, describes the influence of radio-telegraphy on modern strategy. These two articles will probably

appeal to the general reader more than any of the other contents of the whole volume.

During the last year a considerable amount of attention has been devoted among scientific circles to the functions of the earth in wireless telegraphy, and it is interesting to find that the well-known authority, Dr. J. A. Fleming, has contributed an article on this subject. Mr. H. J. Round summarises the progress that has recently been made in wireless telephony. In this connection it is interesting to note that Mr. Round, at Marconi House, was able to converse with Berlin last year by wireless telephone, although his experiments were still incomplete. Dr. W. H. Eccles contributes an article on Radio-telegraphic Research in 1914. Among other interesting articles which find a place in the volume we find contributions on Wireless Long-Distance Service, Wireless Telegraphy and Meteorology, and International Time Signals.

Further matter, which adds to the value of the volume as a book of reference, includes biographical notices of practically everyone of note in the field of wireless telegraphy, a Directory of Wireless Societies, and a long list of patents applied for during 1914.

\* \* \*

“ELECTRICITY OF TO-DAY: ITS WORK AND MYSTERIES.” By Charles R. Gibson, F.R.S.E. London: Seeley, Service & Co., Ltd., 38 Great Russell Street.

The old complaint that the German nation is ahead of ourselves in the matter of applied science is with us once again. Pessimists are greeting every German surprise on the battlefield, humane and otherwise, with “I told you so.”

If the British masses show a greater relative ignorance of technical matters than their continental neighbours it is the fault of their educational system rather than their aptitude. The “modern side” of public school life is still looked at askance by parents jealous of the “family dignity.” The daily Press, too, has some leeway to make up in interesting the public in scientific developments, though there has been a move in this direction in recent years.

At present we are still largely dependent upon popular treatises issued by the great British publishing houses, but many of these

just fail through their inability to keep clear of mathematics. We know it is very difficult to explain certain phenomena without resort to formulæ, but he who once abandons simile in a work of general public interest runs a grave risk of depriving the whole of his efforts of their value. The man in the street is more scared by a cosine and square root than he is by Zeppelins and scarlet fever.

Herein lies the outstanding merit of Mr. Gibson's really attractive work. When the first edition was published in 1907 it struck a new note in scientific literature. There is no question but that it has gained many recruits for the electrical professions, and has lifted the veil for thousands upon mysteries of a baffling description. Mr. Gibson has discovered the secret of being homely: his ability to weave romance into a fabric hitherto lacking in human interest has given him the success so vainly sought by many who have essayed similar tasks.

The edition now before us excels all others inasmuch as it gives greater attention to wireless telegraphy and telephony than was possible in 1907. Mr. Gibson has followed not only the development of the Marconi system, but all the other systems that have gained more than passing prominence. By way of emphasising the delicacy of construction of some of the parts of a wireless equipment he details the manufacture of the “barretter” or detector invented by Professor Fessenden. This, he explains, consists of a platinum wire one-thousandth of an inch in length, and one-twenty-five-thousandth part of an inch in diameter. In a chapter on telephones, he reminds us of an oft-forgotten fact that a wireless telephone existed long before any wireless telegraph experiments were made. The radius of action, however, was very limited, as speech was actually transmitted along a beam of light.

To readers of THE WIRELESS WORLD the chapters on Wireless Telegraphy and Telephony will be appreciated as setting old facts in a new and popular light. The author makes no pretence at introducing new theories, but wireless enthusiasts may find in the chapter on Medical Applications facts that are little known even to those who make electrical phenomena their constant study. How many of us, for instance, are aware

that the X-rays have a useful field in dentistry, or that high-frequency currents may be used as an anæsthetic for superficial operations? These facts, and hundreds of others equally interesting, are explained in a specially attractive manner in Mr. Gibson's really excellent book.

\* \* \*

"ELECTRICAL INSTRUMENTS IN THEORY AND PRACTICE." By W. H. F. Murdoch, B.Sc., and U. A. Oschwald, B.A. London: Whittaker & Co. 10s. 6d. net.

The importance of measuring and testing instruments to those who are concerned with any form of electrical engineering cannot, of course, be overrated, and any book which assists to a clearer understanding of the principles on which these instruments are based will be welcomed in many quarters. In the book under review the authors set out to deal with something more than the elementary theory of electrical measuring instruments, and by selecting instruments which are typical of their class, make plain to the reader the underlying principles.

Chapter 1 is devoted to an historical summary. The "wireless" student and experimenter will find on pages 11, 12 and 13 an interesting reference to the instruments used for measurement in wireless telegraphy, in which it is made clear that the "skin" effect of high-frequency currents is a very important consideration. Chapter 2 deals with the damping of various instruments. Next follow chapters dealing in detail with moving coil, iron-cored, hot-wire and other instruments, the text being illustrated by numerous diagrams. A large section of the book is devoted to the theory of supply meters of all types—an extremely important subject in these days when electricity is so widely used both domestically and commercially—and the concluding chapters treat of magnetic testing instruments and the Post Office box.

Oscillographs and many alternating current instruments have not been dealt with in this book, as it is the intention of the authors to deal with these in a further volume.

The book is of a convenient size, well printed and on good paper. The diagrams have also been very clearly prepared. The

authors have certainly prepared a work of great value, and one which will doubtless occupy an important place on the bookshelves of many theoretical and practical electricians.

#### GERMAN WIRELESS IN AMERICA.

Senator Marconi attended the hearing on May 5th in the Federal Court, Brooklyn, U.S.A., of the suit of the American Marconi Company against the Atlantic Communication Company operating the Telefunken system at Sayville. The plaintiffs contended that the German concern is using two patents, one invented by Senator Marconi and the other bought by him from Sir Oliver Lodge. Senator Marconi will probably give evidence regarding the facts of the case.

#### WIRELESS ORNITHOLOGY.

A West of England newspaper prints a paragraph in which it states that some birds—particularly sea-gulls—are disturbed in a very curious way by wireless waves. We would like to point out to our contemporary that they are not the only "gulls" affected by wireless.

#### A TRIBUTE TO RADIO-TELEGRAPHY.

A British explorer and elephant hunter writing from Bangui, French Equatorial Africa, to a Yorkshire newspaper makes the following remark:

"It will interest all your readers to know that, thanks to 'Wireless' linked up by land services, we—in the heart of Africa (over six thousand miles from Europe)—receive daily reports of the progress of battles now raging in Europe a few hours after the events."

#### SHARE MARKET REPORT.

*London, May 18th, 1915.*

Dealings in the shares of the various Marconi Companies have been on a small scale during the past month although there has been considerable investment buying of the Preference shares. The shares of the American Company have fallen back slightly owing to the unrest in the United States.

The latest prices are: Marconi Ord.,  $1\frac{3}{4}$ ; Marconi Pref.,  $1\frac{1}{2}$ ; American, 10s.; Canadian, 5s.; Marconi Marine,  $1\frac{1}{8}$ .



## QUESTIONS AND ANSWERS

*Readers are invited to send questions on technical and general problems that arise in the course of their work or in their study to the Editor, THE WIRELESS WORLD, Marconi House, Strand, London, W.C. Such questions must be accompanied by the name and address of the writer, otherwise they will remain unanswered: and it must be clearly understood that owing to the Defence of the Realm Act we are totally unable to answer any questions on the construction of apparatus during the present emergency.*

L. E., W. D. (Surbiton), W. C. (Peterborough), C. F. Stoke Newington), C. F. (Watford, Ontario), J. E. P. K. (Cape Town), W. R. (Swinton, Lancs.), Fr. D. (Cherbourg), H. H., Jr. (Rotterdam), M. Bony (Bordeaux), A. Rowlands (Swinton), ask questions which we cannot answer during the present emergency owing to the Defence of the Realm Act.

G. P. (Wavertree) writes concerning the differences of value obtained by working out inductance by the various formulae that have appeared in THE WIRELESS WORLD and the "Year Book." One of the reasons for the differences which have arisen is that the first formulae he quotes are simplified as much as possible, and the results are therefore only fairly approximate. Unfortunately, for several reasons it is impossible to give a formula which is absolutely accurate, but Dr. Cohen's formula in the "Year Book" can be taken as a standard.

N. C. de O. (St. Vincent, Cape Verde Islands) will find what he requires in "Wireless Telegraphy," by W. H.

Marchant, 5s. 4d. post free, from the Wireless Press, Ltd.

W. D. I. (Port Stanley, Falkland Islands) asks whether there is such a thing as a "directional earth," and instances a great improvement which was apparent in his station when an extension of the earth wires was made in the direction from which it was desired to receive signals. The extension wires *terminated in the sea*, which fact, and not the direction, accounts for the improvement of signals. By leading the earth wires into the sea a much better "earth" connection is made. Our correspondent also asks if a number of extensions of the earth wires were made—say one each north, south, east and west—and were brought into the station in such a way that any one of them could be used at choice, whether there would be a directional effect in the direction of the system used. We think not. Any improvement that might become evident through the extension of the earth system would be due to a general improvement in the earth connection as a whole.

## FOREIGN NOTES

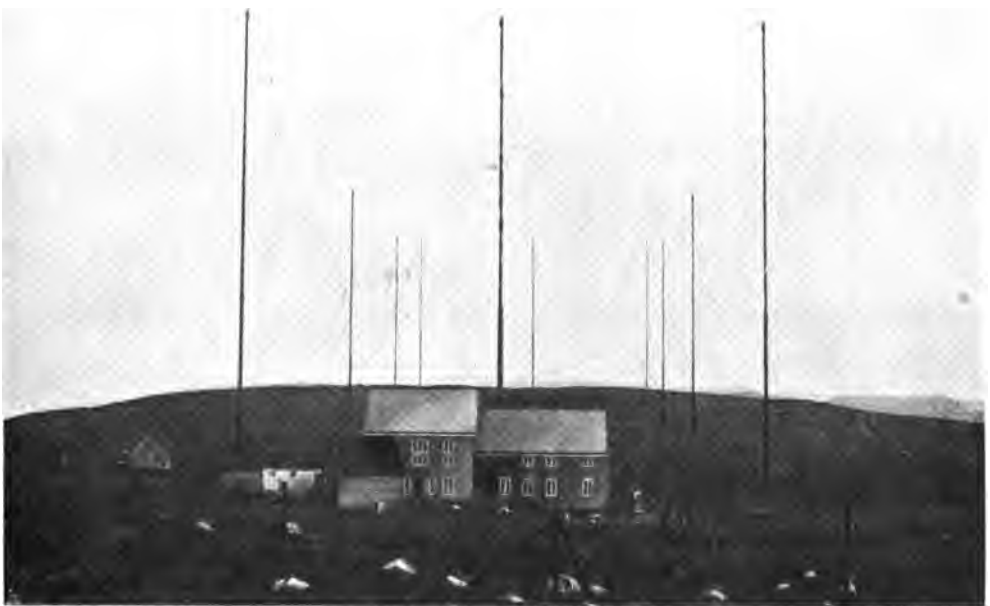

*The Aerials of the new Wireless Station at Stavanger.*

In THE WIRELESS WORLD of February, under the title of "From Continent to Continent," we published particulars of the new wireless station at Stavanger erected recently by the Marconi Company for the Norwegian Government with the object of placing them

in direct communication with the United States of America. We understand that the working of the station is giving great satisfaction to the Norwegian Government, and we produce below a view of the aerials which has just recently come into our hands.

## PERSONAL PARAGRAPHS.



*C. J. Shepherd and his son, A. Shepherd.*

Among the many employees of the various Marconi companies that have left their peaceful callings to wear the "khaki" and go to the war, are Mr. C. J. Shepherd and his son, A. Shepherd. Most of the staff at Marconi House will remember the former as the lift-man at the Aldwych entrance. He is now a corporal in the "Queen's." His son started his career at Marconi House as a messenger boy, and at the time of his enlistment in the Oxford and Bucks Light Infantry, was boy clerk.

We regret to have to record the death of a youthful "wireless" enthusiast in the person of G. D. Lascelles Harcourt, who died on March 29th



*G. D. Lascelles Harcourt.*

at Winchester College, aged sixteen. At the age of thirteen he began the study of Wireless Telegraphy, to which he became entirely devoted, and, young as he was, he constructed his own apparatus, with which he had great success. He was a constant reader of THE WIRELESS WORLD. As his knowledge of the subject increased he continued to improve his wireless plant, and was able to receive from all the principal European stations, including Clifden, Pola, Madrid, and numberless intermediate ones. His early death closes a career which gave promise of considerable achievement in the sphere of electrical science, and we take this opportunity of expressing our sympathy with his relatives in their sad loss.

The Société Anonyme Internationale de Télégraphie sans fil regrets to announce the deaths of three members of its operating staff—F. V. S. Kinch, J. H. Karreman and J. Llué-Garcia.

J. H. Karreman was born at Maassluis, Holland, on April 15th, 1894, and was appointed telegraphist by the S.A.I.T. on August 1st of last year, after having followed a course of training at the Rotterdam School.

F. V. S. Kinch was born at Copenhagen on December 8th, 1892, and received his training in wireless at the Svendborg School in Denmark. He was appointed telegraphist by the S.A.I.T. on August 16th, 1914.



*Mr. J. H. Karreman.*

These two young men were Officer in Charge and Assistant respectively of the wireless station on the s.s. *Prins Maurits*, of the Koninklijke West Indische Maildienst, when that unfortunate vessel was lost with all hands in a gale at sea on April 3rd last.

That they stuck to their post to the last is known from the reports of other vessels that received the distress calls from the stricken ship, and it is profoundly sad that, through stress of weather and other adverse circumstances, no timely assistance could be brought to the sinking ship.

Julio Lluel-Garcia, who was born in Havana on December 12th, 1887, was appointed telegraphist on the staff of the S.A.I.T. on January 1st, 1913. For some time past his health was not all that could be desired, and on February 1st of this year he was taken ill with bronchial fever, from which he died at Jimena, Spain, on April 19th.

The company deeply regrets the loss of these three young men, who all gave promise of a successful career in the service.

We give below a photo of the late M. Joseph van Schoubroeck, which unfortunately came to hand too late for inclusion in our May issue. We would refer our readers to p. 133 of our last number for the particulars of the sad death of this gentleman, who died in Flanders from the effects of an expanding bullet.



*M. Joseph van Schoubroeck.*

Whilst replacing some wires at the Marconi Wireless Station on Cefndu, Mr. Barrington, one of the engineers, who resides at Llannig, touched a live wire, and sustained severe injuries to his hands. He was unconscious for some time after the accident, but subsequently made satisfactory progress towards recovery.

To the roll of honour of those who have lost their lives in the wireless service of the Empire during the present war, must be added the names of George Clarkson and William Henry Silvester, both of whom are reported as having been drowned in the sinking of the trawler *Columbia*. The *Columbia* and some other vessels were attacked on May 1st by two German torpedo-boats, the engagement lasting about a quarter of an hour. The Germans then retreated, and the direction of their retreat having been communicated to British destroyers, these latter gave chase and destroyed the enemy craft. The *Columbia* was, however, sunk, with the loss of sixteen officers and men, amongst whom were Messrs. Clarkson and Silvester, the R.N.R. Warrant Telegraphists of the vessel. George Clarkson, whose home was at Ballingaddy, Kilmallock, co. Limerick, Ireland, was twenty years of age, and was educated at Fermoy and Cork. He entered the service of the Marconi Company as learner in September, 1913, and on appointment to the



*Mr. G. Clarkson.*

operating staff served on the s.y. *Arcadian* and the ss. *Toledo*. At the outbreak of war he volunteered for naval service, and was in due course appointed to the *Columbia*, which was carrying out Admiralty duty. William Henry Silvester, of Reigate, Surrey, was twenty-six years of age and was educated at Folkestone. He entered the Marconi Company from the telegraph staff of the South-Eastern and Chatham Railway, and after serving a short period in the Marconi Company's School, was appointed to the ss. *Victorian*. He afterwards served on the ss. *Merion*, *Haverford*, *Inanda* and a number of other vessels, and for some time previous to the war had been engaged as wireless operator on board trawlers at Hull. On behalf of our readers we offer our sincerest sympathies to the relations of the deceased in the terrible bereavement they have suffered.

We regret to record the death of Lieut. David E. Hooper, who was killed in action on April 30th. Lieut. Hooper, who was the eldest son of Mr. and



*Mr. W. H. Silvester.*



Lieut. D. E. Hooper.

Mrs. David Hooper, of Weston-super-Mare, was born in India in 1893. He was educated at Birkenhead and in Switzerland, and two years ago entered Bristol University as an engineering student, with a view to joining the Public Works Department in England. Deceased was a keen student in wireless telegraphy, and had won a prize offered by the Marconi Wireless Telegraph Company. He was serving in the 3rd Battalion East Lancashire Regiment when he met his death.

Friends and fellow-operators of Sergeant A. H. Brown, of Seapark, Nairn, will be delighted to hear that he has been appointed to a Second Lieutenantcy in the 10th Battalion Seaforth Highlanders. Lieutenant Brown joined the Scots Greys in 1902, and after seven years' service left the Colours with the rank of sergeant. On the completion of his army service he was appointed a clerk in the Nairn Post Office, where he was employed for four years. In June, 1913, he entered the Marconi Company as learner in the Company's London School, and after a short course of training was appointed to the ss. *Aragon*. He afterwards served on board the ss. *Zeelandic* and the ss. *Demerara*. In October last Lieutenant Brown rejoined the Army in the Greys, and has since been stationed at Dunbar. Lieutenant Brown is the only son of the late Mr. C. H. S. Brown, who was postmaster of Nairn for a number of years. We offer Lieutenant Brown our heartiest congratulations.

The *Yorkshire Daily Herald* publishes a portrait of Corporal J. H. B. Taylor, of the Northern Wireless Section, Royal Engineers, now on active service. He is one of the old boys of the Scarborough Municipal School, and at the age of 13 years won the Science and Art Scholarship of South Kensington.

## PATENT RECORD.

The following patents have been applied for since our March issue :

(MARCH, APRIL, MAY, 1915.)

4604. March 24th. Fred. L. Field, C. Lewis Fortescue, and Brian S. Gossling. Receiving instrument for wireless telegraphy. (*Provisional.*)

4862. March 29th. Henry R. Rivers-Moore. Electric oscillating system. (Addition to No. 1649/1910. *Provisional.*)

5342. April 9th. Gesellschaft für Drahtlose Telegraphie M.B.H. Receiving arrangement for wireless telegraphy. (*Complete.* Convention date, April 9th, 1914. Germany.)

5630. April 14th. Wm. J. Mellersh-Jackson. Mounting of electric oscillators for submarine signalling. (Submarine Signal Co., U.S.A. *Provisional.*)

5783. April 17th. Marconi's Wireless Telegraph Co., Ltd., and Chas. S. Franklin. Aerial conductors for wireless telegraphy. (*Provisional.*)

5784. April 17th. Marconi's Wireless Telegraph Co., Ltd., and Chas. S. Franklin. Means for indicating and correcting small changes in the speed of a machine. (*Provisional.*)

5794. April 17th. Edison & Swan United Electric Light Co. and Stanley R. Mullard. Electric arc-forming device for use in electric valves or rectifiers or in oscillation generators. (*Provisional.*)

5955. April 20th. Lucien Rouzet. Polyphase generators for high-frequency currents with polyphase tuned spark-gap. (Addition to No. 519/15. Convention date, April 20th, 1914, France. *Complete.*)

6217. April 26th. Chester M. Agner. Wireless telegraphy. (*Complete.* Convention date, June 8th, 1914, United States.)

6296. April 27th. Louis Mauclair and Alfred Bréon. Arc lamps adapted to be used also for the production of electrical oscillations for wireless telegraphy, wireless telephony, and for other purposes. (*Provisional.*)

6476. April 30th. Marconi's Wireless Telegraph Co., Ltd., and Henry J. Round. Cathodes of vacuous tubes suitable for use in wireless telegraphy. (*Provisional.* Divided application on No. 13,247/14.)

6486. April 30th. Lee de Forest. Wireless telegraph and telephone systems. (*Provisional.*)

6551. May 1st. Oliver Imray. Arrangements for transmitting and receiving signals by electromagnetic waves. (*Complete.* Samuel M. Kintner and Halsey M. Barrett, United States.)

6669. May 4th. John Hays Hammond. Gaseous or vacuized detectors for radiant energy and method of controlling the action thereof. (Addition to 8,568/14. *Complete.*)

6753. May 5th. Guillaume A. Nussbaum. Microphones for wireless telegraphy. (*Provisional.*)

6813. May 6th. Axel Orling and Orling's Telegraph Instruments Syndicate, Ltd. Means for amplifying the effects of small vibrations for telegraphic and other purposes. (*Provisional.*)

# COMPANY NOTICES

## AMALGAMATED WIRELESS (AUSTRALASIA) LIMITED.

**T**HE half-yearly ordinary general meeting of the Company was held at Sydney on March 18th last to receive the balance sheet and report of the Directors of the Company for the half-year ended December 31st, 1914, Mr. H. R. Denison, Managing Director, presiding.

The Directors' report states that trading for the period had been satisfactory from various points of view, but it must be borne in mind that certain departments of the Company had been much disturbed since the commencement of the war.

The ships' message traffic, upon which the Company depends for part of its profits, had been reduced to a low ebb, which, under the circumstances, was unavoidable—censorship, naval restrictions, the use of some of the Company's subsidy passenger ships for Imperial purposes, and other causes beyond the control of the Company, had contributed to this result. Fortunately, since the beginning of the current year, conditions had slightly altered for the better, and indicated a gradual upward tendency.

The subsidy ships had slightly increased since the last Directors' report of June, 1914, and stood at 80 passenger and cargo steamers. New business was periodically coming along, and this department was steadily advancing to a satisfactory stage.

Since the outbreak of war over 70 men had been sent away to carry out naval and military work of various descriptions on the battlefields of Europe and Egypt, as well as on transports and special service Government vessels. The Company had successfully coped with all the demands made upon it, thereby proving that its organisation was not only sound commercially, but was also a national asset.

The net profit standing to the credit of Profit and Loss Account amounted to £7,828 17s. 3d., from which the Directors recommended the distribution of an interim dividend of 2½ per cent. on the capital of the Company, which absorbed £3,500, the balance being carried forward to next account.

The Chairman, in addressing the meeting, remarked that the Company had made very material advance in profit earning since the last half-yearly meeting.

He went on to point out that the profit for the six months was greater than that for the previous sixteen months in which the two now amalgamated companies were operating. While they had profited from the fitting out of troopships that revenue would be non-recurring. At the same time there had been such an immense falling off from ships' traffic during the war that it might fairly be said that the one balances the other. They might expect after the war to make up that falling off in traffic earnings, and that would replace the non-recurring revenue from the troopships.

The profit made would have justified giving the shareholders a rather larger dividend than had been recommended, but it was thought that as this was only a half-yearly meeting, an interim dividend should not be up to the full amount that could be declared, but that something should be kept in hand until the full accounts for the year came forward.

On the basis of the half-year's trading it was reasonable to expect that the next dividend would be increased. They had reason to be proud of the result, for there had been many difficulties to contend with. They had not received any help where they might reasonably have expected help, and that the Company should have been able to make an amount equivalent to 10 per cent. of its capital spoke well for the future.

The half-yearly report and balance-sheet were adopted unanimously, and the interim dividend at the rate of 2½ per cent., absorbing £3,500, was passed. The sum of £4,328 was carried forward to next account.

In proposing a hearty vote of thanks to the Chairman of Directors, which was carried unanimously, Mr. W. Fordyce Wheeler said the position of the Company reflected the highest commendation upon the management. The result was more than satisfactory.

## MARCONI WIRELESS TELEGRAPH CO. (AMERICA).

**W**E printed in our last issue the preliminary report and statement of accounts of the above company for 1914. The annual meeting took place at the registered office of the company in Jersey City on April 19th. It was then stated that the acquisition in 1912 of the tangible assets of the United Wireless Company by this company placed under its control all the coast stations of importance on both the Atlantic and Pacific coasts, besides which practically the whole of the American mercantile marine is now fitted with wireless apparatus. The number of ship and shore equipments which it works is approximately twenty times as large as it was three years ago. This remarkable growth has necessitated a proper organisation to operate the company as an institution of national importance, and the development of a competent working staff to conduct the business economically and efficiently, which achievement has been one of the most noteworthy of the past twelve months.

In conformity with public demand, the company's service has been steadily extended and its apparatus developed to a standard recognised by the Government, the steamship owners, railroads, and large industrial companies. In order to secure a return commensurate with investment and cost of operation, it was found necessary to raise the rental of ship equipment contracts taken over from the United Wireless Telegraph Company. As rapidly as the old contracts expired they have been renewed at a higher figure and the officers report that they have been able to convince steamship owners of the justice of the rate of increase. In addition to the progress made in ship and shore communication, much has also been accomplished during the year with high-power stations for long-distance work. In the northern district of the Pacific coast there has been completed a powerful station at Ketchikau, Alaska, and a chain of wireless stations to cover this large territory has been planned. At Juneau the company has another station under construction, and the United States terminal at Astoria, Oregon, is nearing completion. Trans-Pacific service between San Francisco and Honolulu was opened on September 24th and with few in-

terruptions has been working continuously ever since.

The direct New York-London service had to be suspended at the outbreak of war.

The duplex stations at Belmar, N.J., and New Brunswick, N.J., were completed and being tested when word came through that the corresponding English stations at Carnarvon and Towyn had been commandeered by the British Government for the use of the Admiralty. This was a serious blow to the company's hopes. A transoceanic department had been organised and a twenty-four hour service was to have been provided through a new commercial office opened in the heart of the New York financial district.

The financial statement of the company for the year under revision appeared in our May issue.

---

**WANTED.**—Volume I. (bound or otherwise) of the **WIRELESS WORLD.**—Apply G. H. WHITE, wireless operator, R.F.A. *Reliance*, c/o G.P.O., London.

**THE YEAR-BOOK OF WIRELESS TELEGRAPHY & TELEPHONY, 1915,** now ready. Price 3/6 net; post free in United Kingdom 4/-; Abroad 5/-.—**THE WIRELESS PRESS, LTD.,** Marconi House, Strand, W.C.

**THE ELEMENTARY PRINCIPLES OF WIRELESS TELEGRAPHY,** by R. D. Bangay. Price 1/2 post free. A book eminently suitable for the beginner.—**THE WIRELESS PRESS, LTD.,** Marconi House, Strand, W.C.

**HANDBOOK OF TECHNICAL INSTRUCTION FOR WIRELESS TELEGRAPHERS,** by J. C. Hawkhead. Price 3/6. A complete Course for the P.M.C.'s Certificate.—**THE WIRELESS PRESS, LTD.,** Marconi House, Strand, W.C.

**BINDING CASES** for Volume II. of **THE WIRELESS WORLD** are now ready. Price 1/3 post free.—**THE WIRELESS PRESS, LTD.,** Marconi House, Strand, W.C.

**COPIES** of Volume II. of **THE WIRELESS WORLD,** cloth bound, bevelled boards, are now on sale. Price 4/6 net. Postage for United Kingdom, 8d. Abroad at Foreign Parcel Post Rates. As only a limited number are prepared, orders should be placed at once.—**THE WIRELESS PRESS, LTD.,** Marconi House, Strand, W.C.

**SPECIMEN COPIES.**—We shall be pleased to send entirely free of charge a few specimen copies of **THE WIRELESS WORLD** to the friend of any reader likely to be interested in the magazine.—Send a postcard to Sales Manager, **THE WIRELESS WORLD,** Marconi House, W.C.

**MORSE CODE CARD,** showing Alphabet, Numerals, Abbreviations, etc., at a glance. Price 2d. post free.—**THE WIRELESS PRESS, LTD.,** Marconi House, Strand, W.C.

**ANY BOOKS** reviewed in the **WIRELESS WORLD** or other magazines will be forwarded per return upon receipt of remittance covering cost of book and postage.—**THE WIRELESS PRESS, LTD.,** Marconi House, Strand, W.C.

**MARCONI OPERATORS** and others studying Wireless Telegraphy will find our series of Test Cards and books of Model Answers of considerable assistance in attaining proficiency. Full particulars on page xiii of this issue.

**MAP OF THE WORLD,** revised March, 1915. Showing location of over 700 Wireless Stations. Price 1/8 post free.—**THE WIRELESS PRESS, LTD.,** Marconi House, Strand, W.C.

**YEAR BOOK OF WIRELESS TELEGRAPHY AND TELEPHONY, 1914.** Twelve copies only available, otherwise out of print. Price 3/- each, post free.—**THE WIRELESS PRESS, LTD.,** Marconi House Strand, W.C.