

Price 9d. Net.

W. W. COMPETITION, SEPT.

SEPT., 1919.

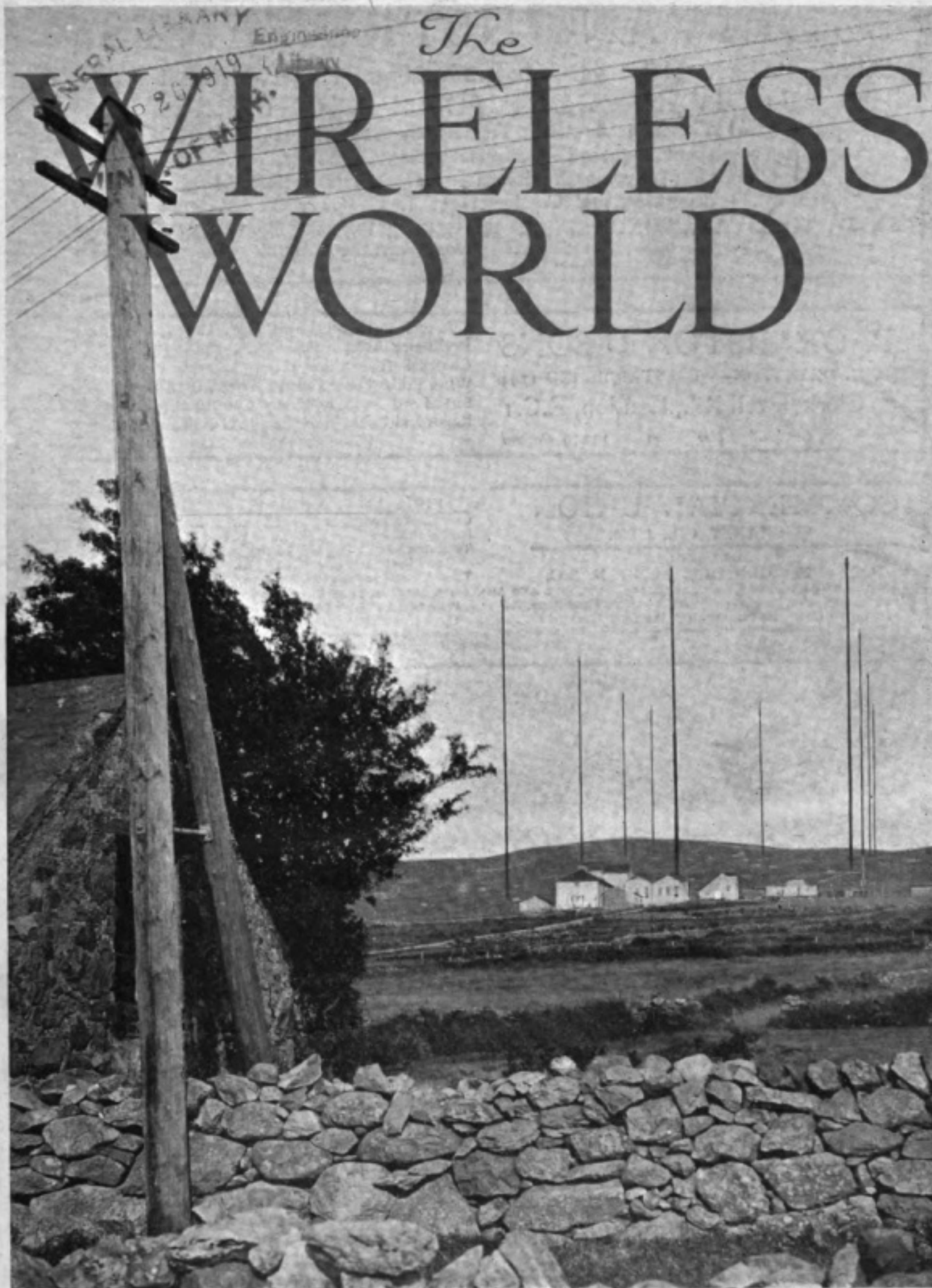

**"ANTI-SULPHURIC" ENAMEL  
RESISTS ACID FUMES, Etc.**

**GRIFFITHS BROS. & Co. (London) Ltd  
MACKS ROAD, BERMONDSEY, S.E.Y., Y**

Original from  
UNIVERSITY OF MICHIGAN

# SULLIVAN INSTRUMENTS

Sullivan "Universal" Galvanometers and Shunts for Land and Sea use

## SULLIVAN TELEPHONE RECEIVERS

Fast Speed Wheatstone Automatic Transmitters and Receivers guaranteed at 400 words per minute, and Wheatstone Apparatus generally. Precision and Standard Measuring Equipments for D.C. and A.C. (high frequency) determinations, Condensers of Low Power Factor, etc

H. W. SULLIVAN, WINCHESTER HOUSE, LONDON, E.C., ENGLAND

Telegrams— "Deadbeat, London." Telephone: Office: 3518 London Wall. Works: 4871 Avenue. WORKS: LIVERPOOL HOUSE, MIDDLESEX STREET LONDON, EC.

## P. ORMISTON & SONS

(P. H. ORMISTON) :: ESTABLISHED 1793

79 Clerkenwell Rd., London, E.C.1

"Ormiston, London." :: :: 13259 Central

Silk and Cotton Covered H.C. Copper Wire, Resistance Wires, Fuse Wire, Binding Wires, Charcoal Iron Core Wire, Asbestos Covered Wire, Braided and Twisted Wires, Bare Copper Strand and Flexibles of any Construction, Wire Ropes and Cords (fine sizes) in Galvanized Steel, Phosphor Bronze, &c.

## COMMERCIAL UNION

ASSURANCE CO., LTD.

Head Office:

24, 25 & 26, CORNHILL, LONDON, E.C.

The following classes of Insurance effected: FIRE, LIFE AND ANNUITIES, MARINE, LEASEHOLD REDEMPTION AND SINKING FUND, ACCIDENT, including Personal Accident, Third Party, Burglary, Plate Glass, Fidelity Guarantee, Employers' Liability and Workmen's Compensation, including Domestic Servants' Insurance. The Company also act as TRUSTEES AND EXECUTORS.

### FIRE, LIFE, MARINE, ACCIDENT.

Capital fully Subscribed	...	...	...	£2,950,000
Capital Paid Up	...	...	...	£295,000
Total Assets (including Life Funds)	...	...	...	£24,902,252
31st December, 1913	...	...	...	£8,500,000
Total Annual Income exceeds	...	...	...	£8,500,000



## THE BRITISH SCHOOL OF TELEGRAPHY Ltd.

179, CLAPHAM RD.  
LONDON, S.W.

EXPERT TRAINING FOR YOUNG GENTLEMEN (15-25) IN INLAND, CABLE & WIRELESS TELEGRAPHY. Good Appointments are open to our students as soon as qualified, the demand for Skilled Operators in all Services being greater than the supply. Special Short Course suitable for men wishing to obtain Government Certificate and enter the service of the Marconi Co. At several recent Government Exams, all candidates obtained 1st Class Government Certificate. No Branches or Postal Tuition. Fees moderate. Recognised by the War Office, Admiralty, Wireless Telegraph and Cable Companies.

WRITE FOR PROSPECTUS. A. W. WARD (Manager). 'Phone: BRIXTON 215

# THE WIRELESS WORLD

No. 78  
Vol. VII



SEPTEMBER,  
1919

## Great Wireless Stations CARNARVON

**T**HE Carnarvon Wireless Station is situated at Ceunant, Llanrug, five miles from the historic town of Carnarvon. Built on the site of Cefn Du, 800 feet above the sea level, it commands a magnificent view of the Menai Straits, and on very clear days, of the Wicklow Hills. To the eastward, along the line of the aerial, the ground rises about 1 in 10 to the top of the hill which is 1,450 feet high. The last set of masts supporting the aerial is 1,100 feet above the sea level and at this point a fine view of the Snowdon Range is seen, the Snowdon Peak being about six miles distant.

The station of which we write has already been described in a previous issue of the *WIRELESS WORLD*, but we are now able to give many more interesting details of the arrangements there, especially with regard to the powerful new transmitting plant recently installed.

The aerial is of the Marconi directional type, so arranged that the maximum radiation is in the direction of New Brunswick, New Jersey, with which

station commercial service will shortly be carried on. The wires, of which there are 20, are of 7/18 silicon-bronze, the breaking strain of which is 1,300 lbs. Each wire is 3,600 feet long and is separately hung by insulators from steel triatics supported by steel masts 400 feet high. There are 10 of these masts supporting the four triatics which have an average length of 500 feet, the distances between the triatics being 900 feet. Owing to the greater strain at the ends of the aerial three masts are provided to support the end triatics (which are split into two), two masts being provided for each of the inner triatics. The natural wavelength of the aerial is 5,600 metres, and adjustable inductances to carry 300 amperes are provided for increasing this wavelength to 14,000 metres. The effective capacity of the aerial at the latter wavelength is .04 mfd and its resistance 2.1 ohms.

The electrical energy used for the wireless plant, heating and lighting, is obtained from the North Wales Power and Traction Co.'s Hydroelectric Station at Cwm-Dyli which is about two miles on the east side of Snowdon.

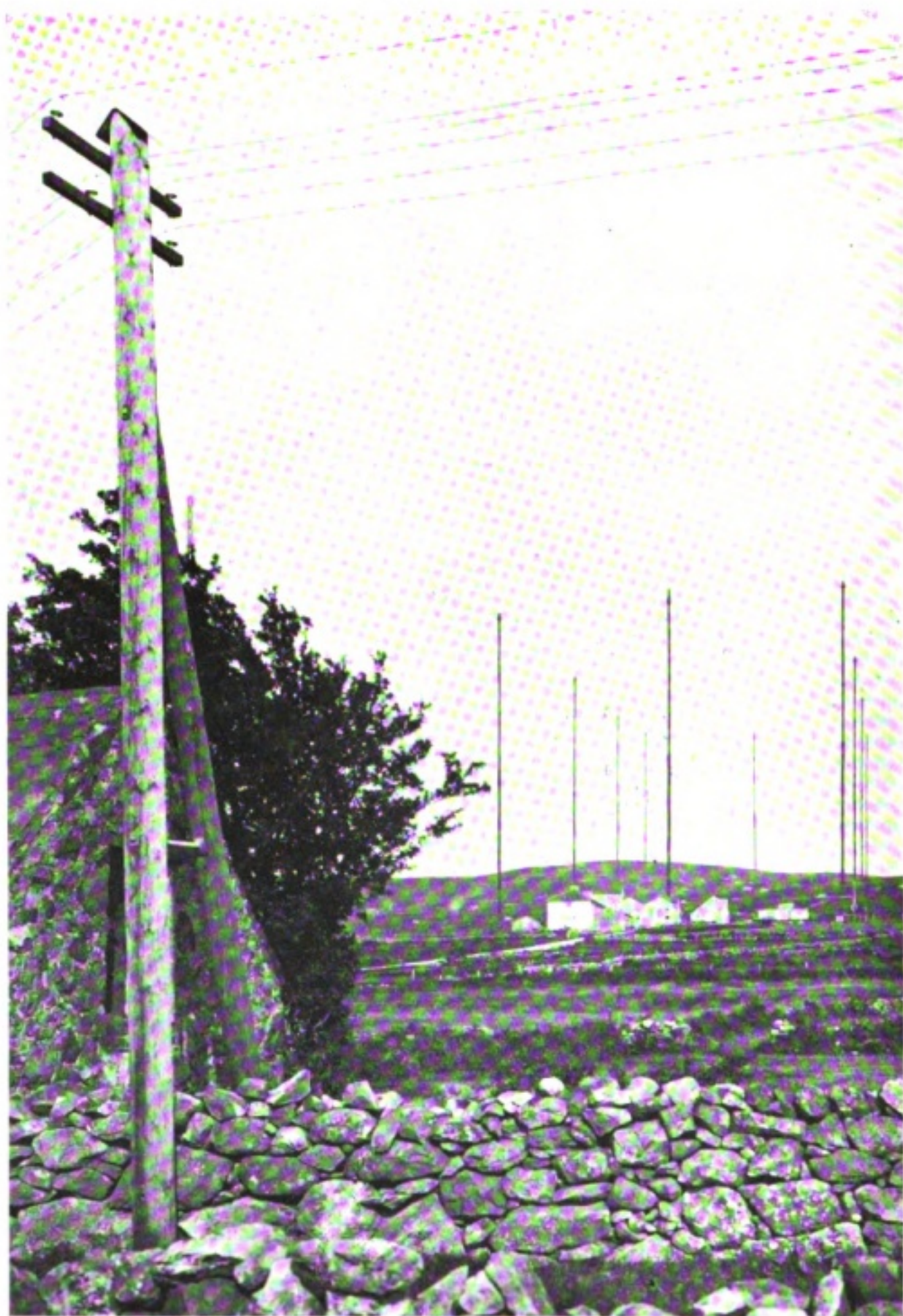

*General View of Carnarvon Station.*

## CARNARVON STATION.

It is of interest to note that here is one of the few places in the British Isles where we are able to use "white coal" or the natural energy of falling water, for this power station utilises the waters of Llyn Llydaw which are led through pipes to the water turbines 1,000 feet below the level of the lake. The turbines are direct coupled, the 3-phase alternators generating at 10,000 volts supplying the slate and stone quarries in addition to the wireless station. Two aluminium power lines each of 500 k.w. capacity carry the current from the power station to the Mar-

vided with "no volt" and "overload time limit" releases, a voltmeter, ammeter, kilowatt meter, power factor meter and frequency meter. The remaining panels on the board are equipped with switches and gear for the control of the motors driving the high tension direct current generators, the motors driving the alternator sets, the motors driving the low tension D.C. auxiliary machines, the high tension alternators, direct current motors, and of all the lighting, heating and various other circuits.

There are three distinct types of trans-



*Station Buildings, Carnarvon.*

coni station, one being a line for the exclusive use of the latter, the other being the branch of a line supplying one of the slate quarries and used as a spare.

At the wireless station two 500 k.w. transformers connected to each power line transform the current down from 10,000 volts to 440 volts at which power it appears on the main switchboard.

The main switchboard is of the Ferranti type and consists of 12 panels. From the feeder panel cables are taken to the main switch panel on which is mounted a hand-operated oil switch pro-

mitters installed (1) the synchronous alternating current sets; (2) Marconi "timed-spark" continuous wave machine; (3) the arcs.

The synchronous A.C. sets are in duplicate and are of 300 k.w. capacity, each consisting of a 450 B.H.P. 440 volt 3-phase asynchronous motor driving a 300-k.w. single phase alternator, the working voltage of which is 1750 volts. An extension of the alternator shaft drives the disc discharger through an insulating coupling. The primary condenser bank has a capacity of 2.5 mfd

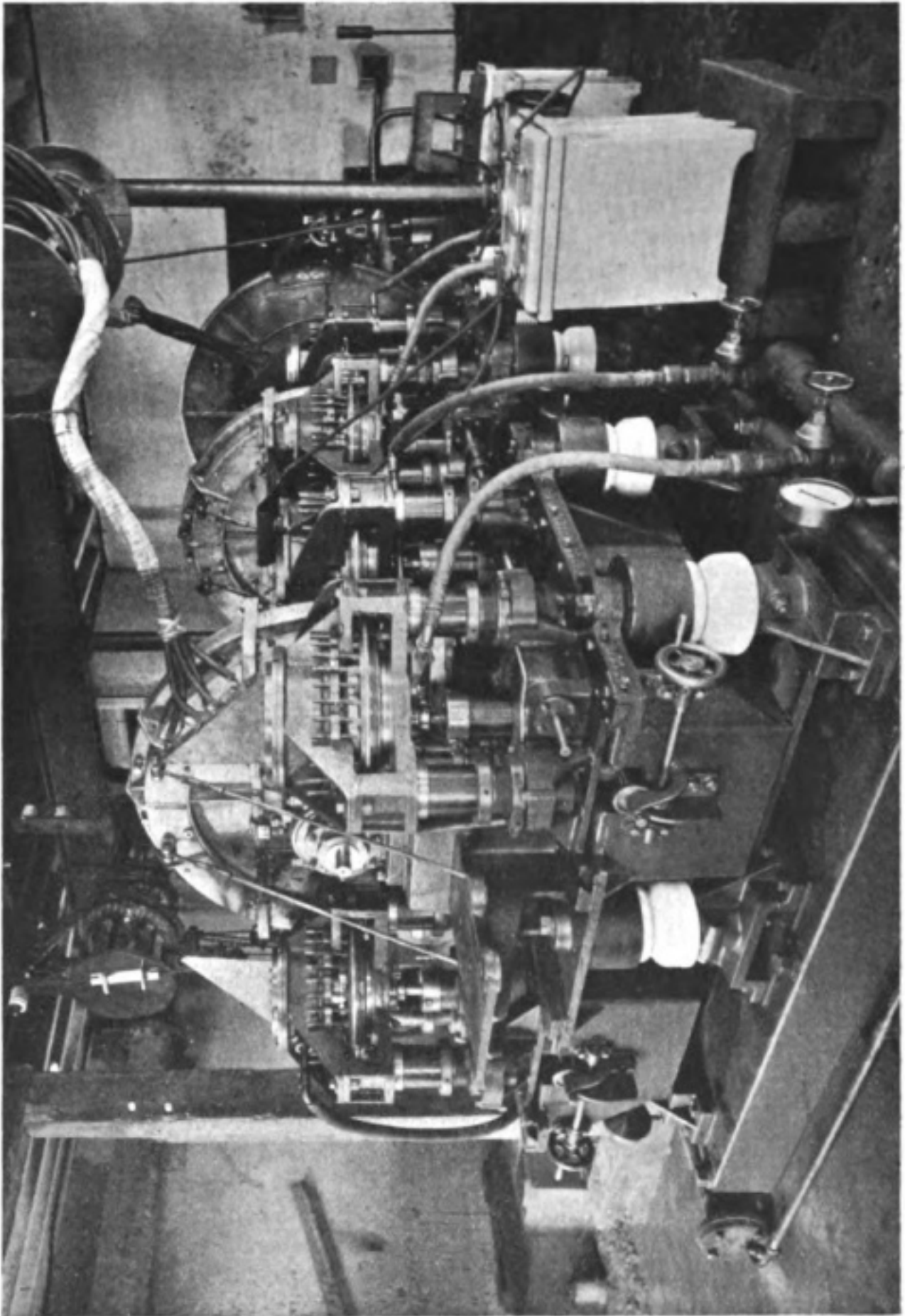

*The "Timed Spark" Discharger.*

CARNARVON STATION.

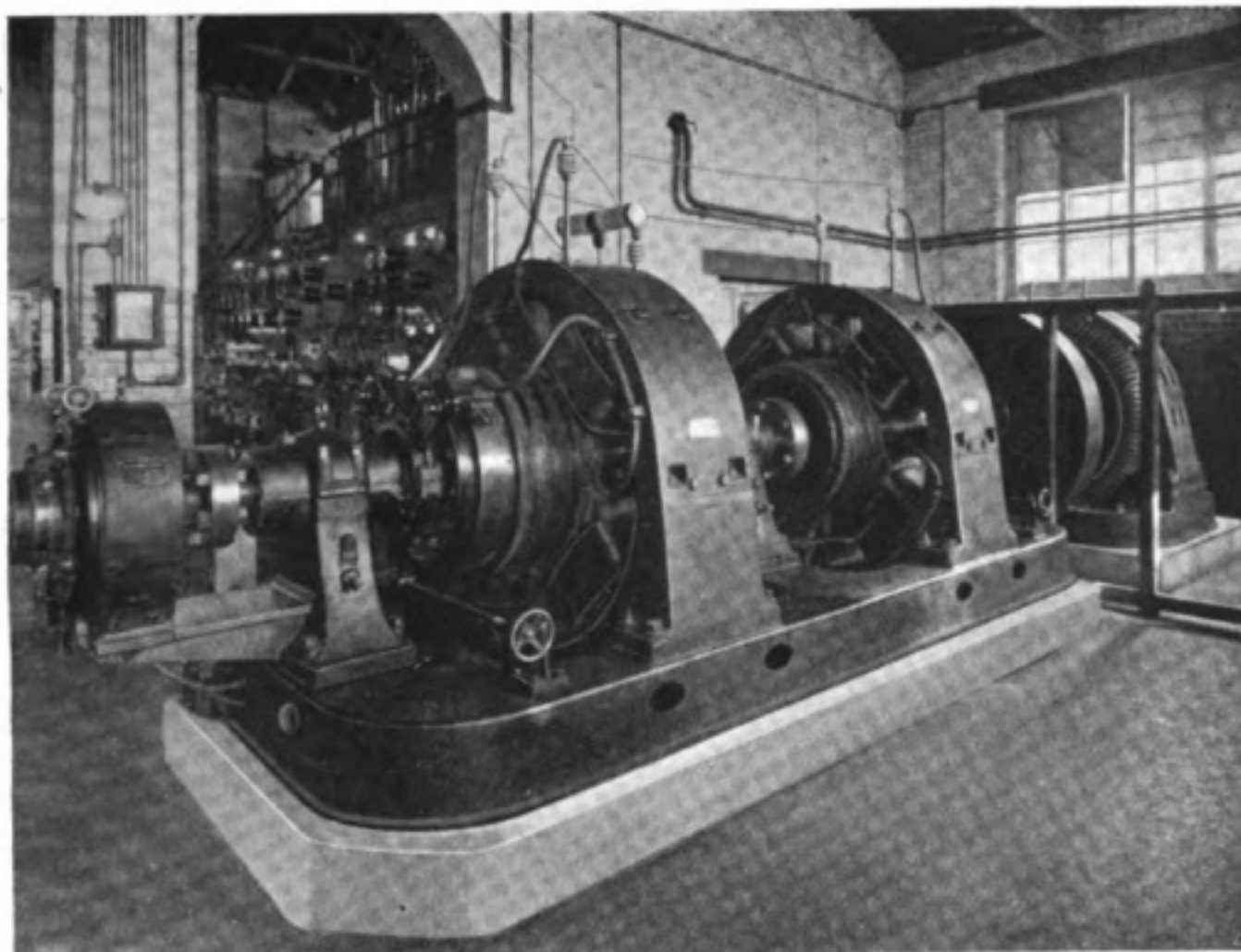

*The Main Switchboard and some of the Machines.*

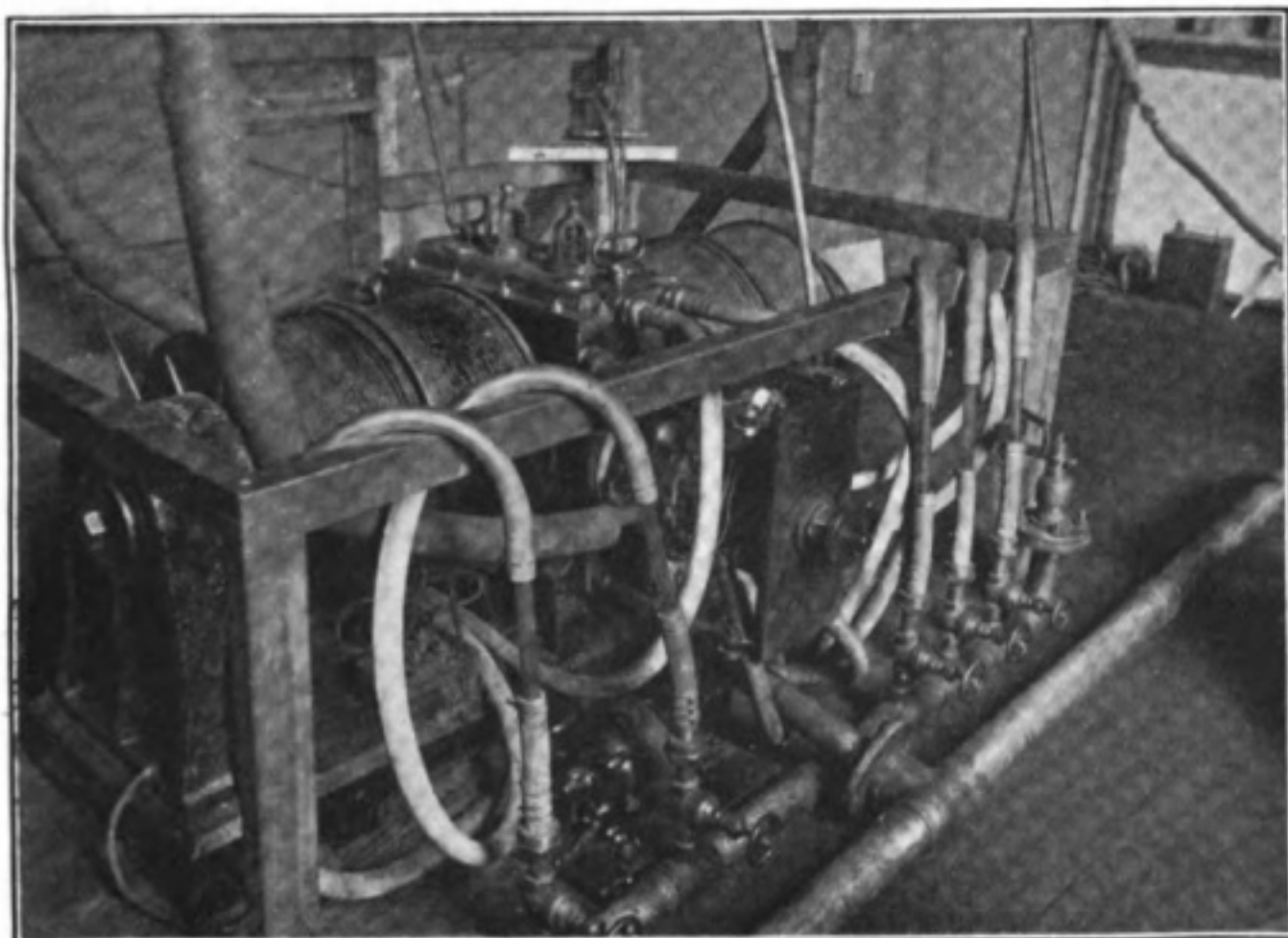

*One of the 200 K.W. Arcs.*

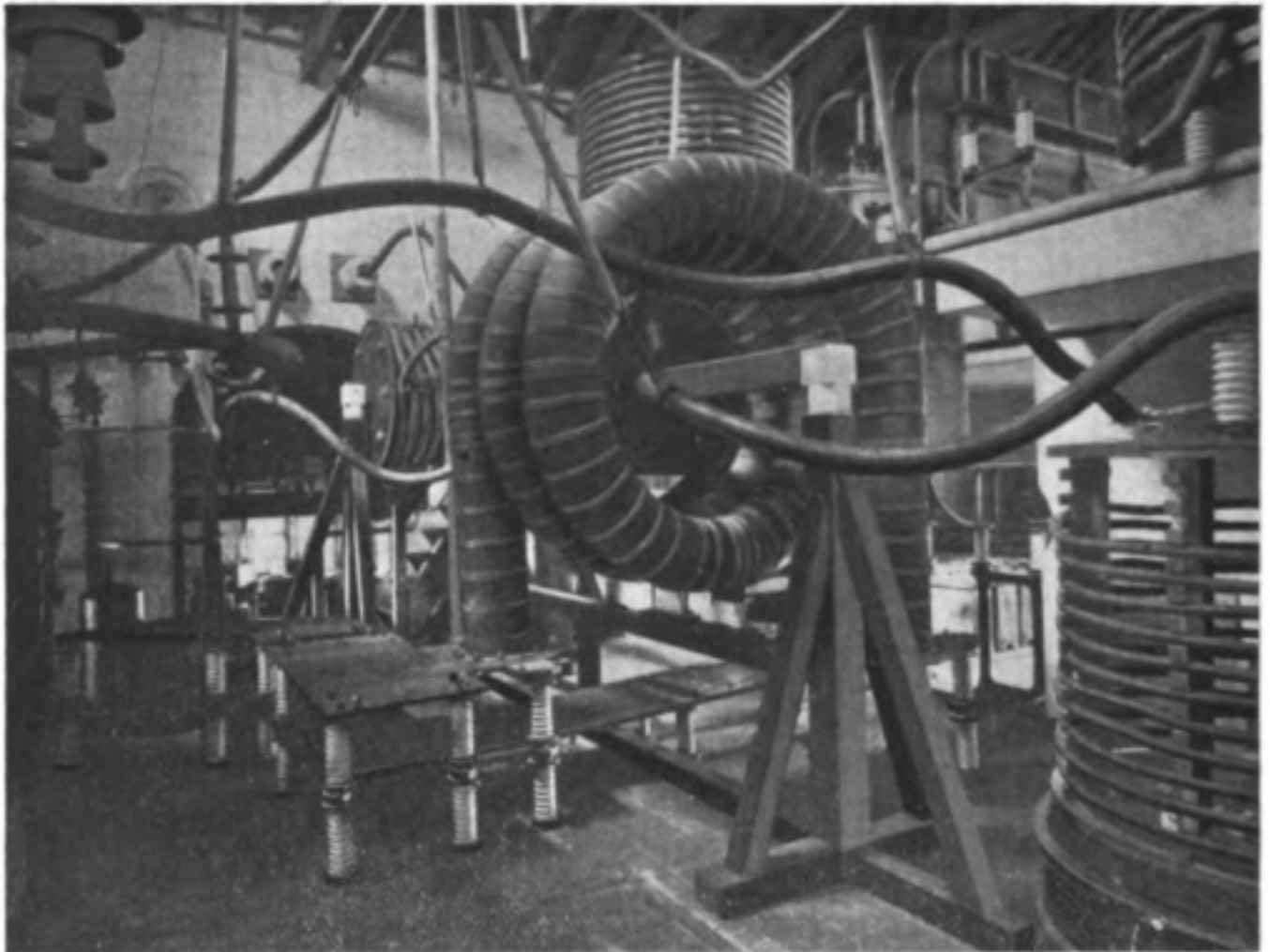

*One of the Jiggers. Note the huge primary winding.*



*The Receiving Room, Towyn.*



## CARNARVON STATION.

and is charged by step-up transformers, the field of which can be adjusted so that the studs on the disc discharge the condenser at each peak of the alternation.

The timed spark continuous wave transmitter has two distinct primary circuits tuned to the same frequency and coupled to the aerial circuit. The condensers of these primary circuits are charged by 5,000 volt D.C. dynamos and discharged alternately by means of a special form of disc discharger so arranged that the trains of oscillations produced in the aerial by the successive discharges of the two condenser banks take place in phase with one another. This timing of the discharges is controlled by a trigger circuit which at a given instant ionises the gap between the studs and electrodes of the main circuits and enables them to discharge, special adjustments being provided for determining the moment of discharge. Signalling is effected by making and breaking the charging current of the trigger circuit, and as this current is only .5 amp. a very high rate of working is possible.

One of these transmitters of 300 k.w. capacity, capable of working at 200 words per minute, is already installed at the station and a duplicate set is in course of erection.

The 200 k.w. arcs are of the horizontal type and are fed through choking coils and starting resistance from a 800 volt D.C. dynamo. The field of the arcs is separately excited from an auxiliary 110 volt D.C. dynamo which also supplies current for the pump motors, cathode motors, and spirit relays. Methylated spirit is automatically fed into the arc chamber which, with its lid,

anode and cathode, is water cooled, a relay being provided in the water circuit to cut off the current to the arc should the water supply fail.

A special receiving station at Towyn is intended for all the receiving and operating work, and is provided with apparatus for duplexing the service. At Carnarvon, however, for special war purposes, receiving apparatus has been installed with a range of from 3,000 metres to 16,000 metres. The aerial is inductively coupled to an intermediate circuit which in its turn is coupled to an amplifying and self-heterodyning valve circuit. By means of magnifiers in the telephone circuit arrangements are made for either automatic reception at high speed, or to enable the operator to receive without wearing telephones. The signalling key for operating by hand is placed in the receiving room, where there is also a Wheatstone automatic transmitter capable of working at a speed of 200 words per minute. For this high speed working high tension signalling switches worked by a Creed compressed air engine is used for slow transmission. Galvanometer type signalling switches are provided, but both types can be operated from relays, either by the hand key or by the Wheatstone transmitter.

Although the Carnarvon station is primarily intended to work to America our article would be incomplete without a reference to the fact that it has successfully communicated with Sydney, Australia, thus proving that it is powerful enough to cope with any distance up to the limit of possible long-distance transmission on the earth, it being understood that modern receiving apparatus is employed at the Antipodes.



*GENERAL GUSTAVE FERRIÉ.*

308

# Personalities in the Wireless World

**G**ENERAL GUSTAVE FERRIÉ, who was born at St. Michel de Maurienne (Savoy) on the 19th of November, 1868, is an old scholar of the Ecole Polytechnique (Paris). He commenced his experiences with wireless telegraphy in February, 1899, by being present during the experiments of Senatore Marconi in wireless working between Wimereux and Dover. Since that time he has continually devoted himself to the science of radio-communication. In 1900 he created the French Military Radiotelegraphic Service, of which he is now the Technical Director.

General Ferrié's personal contributions to the development of wireless are many and important, some of the most interesting being as follows:—

Measurement of wavelengths emitted by antennæ of rather small size and directly excited by means of a horizontal wire, shunted on the earth connection (nodes and loops) (1901). Thermic Ammeter, Wavemeter and adjustable condenser (1902-1903). Thermic Ammeter, Wavemeter and Variable Self Inductance (1902-1903). Direct Reading Wavemeter (two crossed needles) (1909). Several types of revolving dischargers. Tube-disc discharger (1909). Establishment, with Commander Brenot, of the first Automobile Wireless Stations and of the first stations on dirigibles and aeroplanes that ever existed (1909-1912). Installation of the Eiffel Tower Station (Experiments commenced in 1903). Installation for the transmission of time signals: Eiffel Tower Observatory of Paris (1910). Production, with the collaboration of MM. Claude and Driencourt, of a method of comparing clocks by wireless telegraphy by means of which were determined, notably in 1910, 1911 and 1913, the difference of longitude between Paris, Bizerta, Brussels, Washington, etc., with an approximation to the order of one hundredth of a second of time. Collaboration with M. Blondel for the establishment of processes of directional transmission and reception of wireless signals with open and closed frames (1901-1912). Collaboration with the same Physicist from 1902-1908 in the study of the use of alternating current in wireless telegraphy. The association (for the first time) of a closed frame and of an amplifier for long-distance directional receiving (Fort of Palaiseau, November, 1915). This frame has always been employed since that time in the reception of radiotelegrams by the great American stations. In addition to the above-mentioned works, General Ferrié has directed many researches, a few of which are hereafter mentioned:—Special valves which may be used as desired, as detector, amplifier or generator (carried out by M. Abraham) (1915). Special valves of various types (MM. Abraham, Beauvais, Jouaust, Brenot (1915-1919). Production of radiotelegraphic receivers for aeroplanes (carried out by Lieutenants Lévy and Gutton), October, 1915. Wireless telephony between aeroplanes and the ground (January, 1916). Carried out by Lieut. Gutton. Telemechanics: A vessel was able to be directed in the roadstead of Toulon by an aeroplane. Lieutenants Manescau, Guéritot, Brillouin and Abraham. Creation of the great Lyons Station (Captains Péri and Chaulard). In 1904 General Ferrié acted as the Official Representative of France at the International Electrical Congress at St. Louis, U.S.A. He has been the recipient of a very large number of decorations and other honours. He is an Officer of the Legion of Honour and an Officer of Public Instruction, a Commander of the Crown of Italy and an Officer of the White Eagle of Serbia. He has received the Medal for Distinguished Services (United States), and he is a Companion of St. Michael and St. George (Great Britain). Finally, it must be mentioned that a few months ago he was made a Doctor of Science, *honoris causâ*, of Oxford University.

# The Marconi Timed-Spark Continuous - Wave Transmitter

By PHILIP R. COURSEY, B.Sc., A.M.I.E.E.

THE generation of Continuous Oscillations such as are now so extensively used for radiotelegraphic signalling and are of such vital necessity for radiotelephony may be accomplished in a number of different ways. Of these the H.F. Alternator method is undoubtedly the most direct, but it is subject to a number of serious difficulties both mechanical and electrical, that greatly hinder its extended use. Until comparatively recently the Arc has been the source that has found most employment for this purpose, and some very large C.W. arc installations have been built. The Poulsen Arc system comprises the best known examples of such apparatus, and has recently been described in these columns\*

In addition to the above we have "spark" methods and "valve" methods. The use of the three-electrode valve for the production of continuous oscillations of any frequency has been treated in considerable detail in a number of recent articles in this magazine. The Marconi continuous wave apparatus may be classified with the former of these two groups.

The production of a continuous wave from a damped spark discharge as source presents considerable difficulties. Chief amongst these is the fact that in order that the wave radiated from the transmitting station may be undamped, the radiating aerial circuit must receive a fresh supply of energy in *every* cycle

of the oscillation. To accomplish this with a spark transmitter of the usual type would require an extremely high spark frequency of quite impracticable value.

A step in the right direction was made by the introduction of multiphase spark apparatus, in which several quenched or rotary spark gaps were employed, each working on a separate phase of the supply circuit, but feeding on to a common aerial circuit. In this manner the frequency of the discharges at each individual spark gap is reduced in proportion to the number of phases, although the resultant effective high-discharge frequency is maintained. To carry out this method in practice for comparatively short wavelengths (of the order of 600 metres) still, however, demands either a very high spark frequency or a large number of phases. For instance, a 600 metres wave has a frequency of 500,000 per second, so that even if 27 phases were employed the individual spark frequency would still be 18,500 per second, which is too high to be readily workable. By reducing the number of discharges to be an exact sub-multiple of the oscillation frequency it is possible to secure a fresh energy impulse to the aerial circuit once in every two, three or more oscillations instead of once in every one. The wave radiated will not then be quite undamped, but will still be continuous, although the amplitude will be waxing and waning slightly between successive spark discharges.

\* Vol. VII., p. 8, April, 1919.

## THE MARCONI TIMED-SPARK CONTINUOUS WAVE.

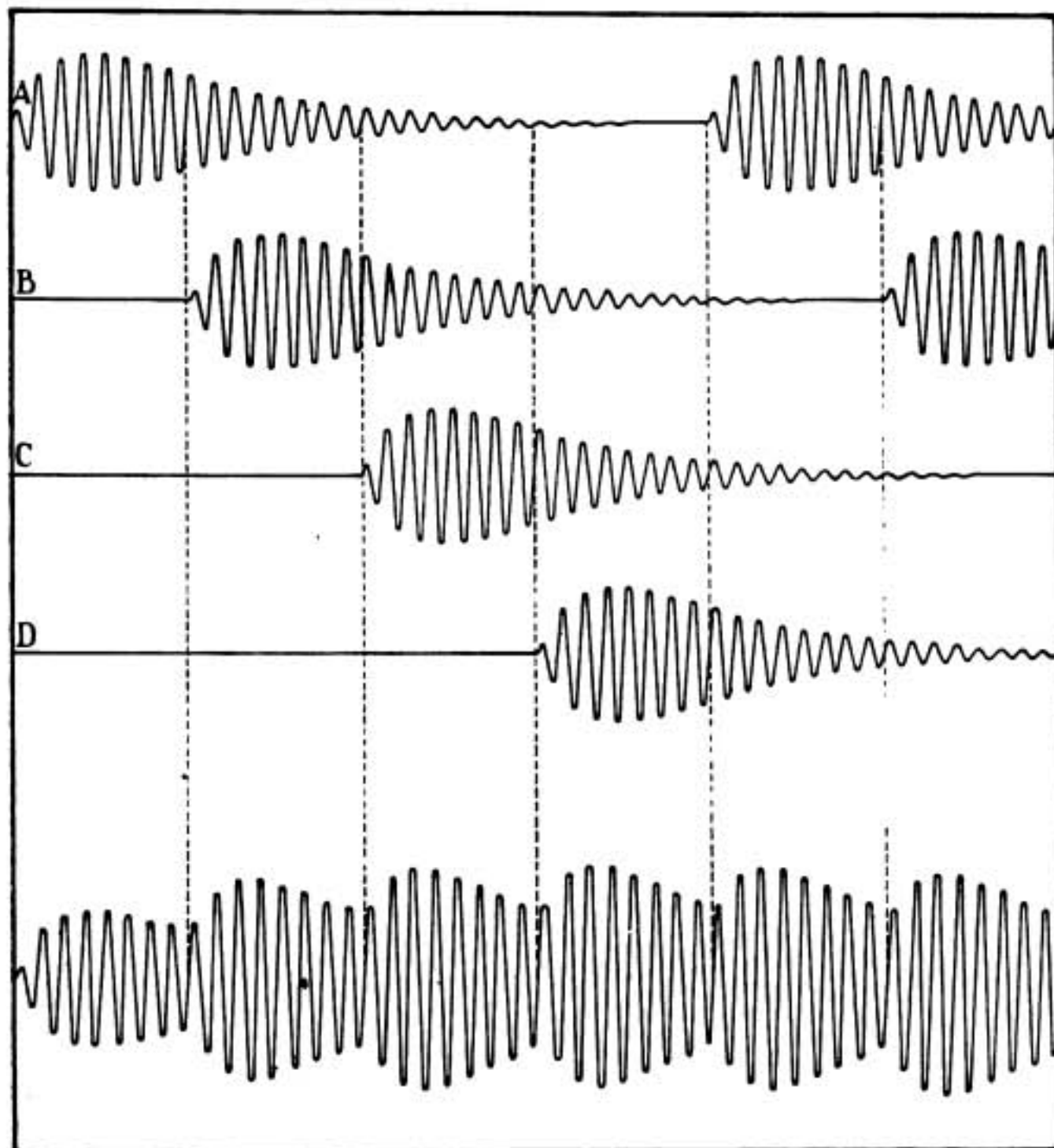

Fig. 1.

One of the chief difficulties experienced with these arrangements is that of ensuring that the successive discharges shall occur in the proper phase relation to the oscillations existing in the aerial circuit. If this phase coincidence is not secured the energy imparted to the aerial by one discharge may sometimes help and sometimes hinder the oscillations already existing. The magnitude of this effect is illustrated diagrammatically in Figs. 1 and 2.

These diagrams illustrate the case when the oscillation frequency is eight times the effective spark frequency. In Fig. 1 the fresh oscillation trains start exactly in synchronism with the aerial oscillations in each case, whereas in Fig. 2 the successive wave trains are displaced through half a period from the correct position. The poor quality of the resultant wave in the latter case is very evident.

It has been found experimentally

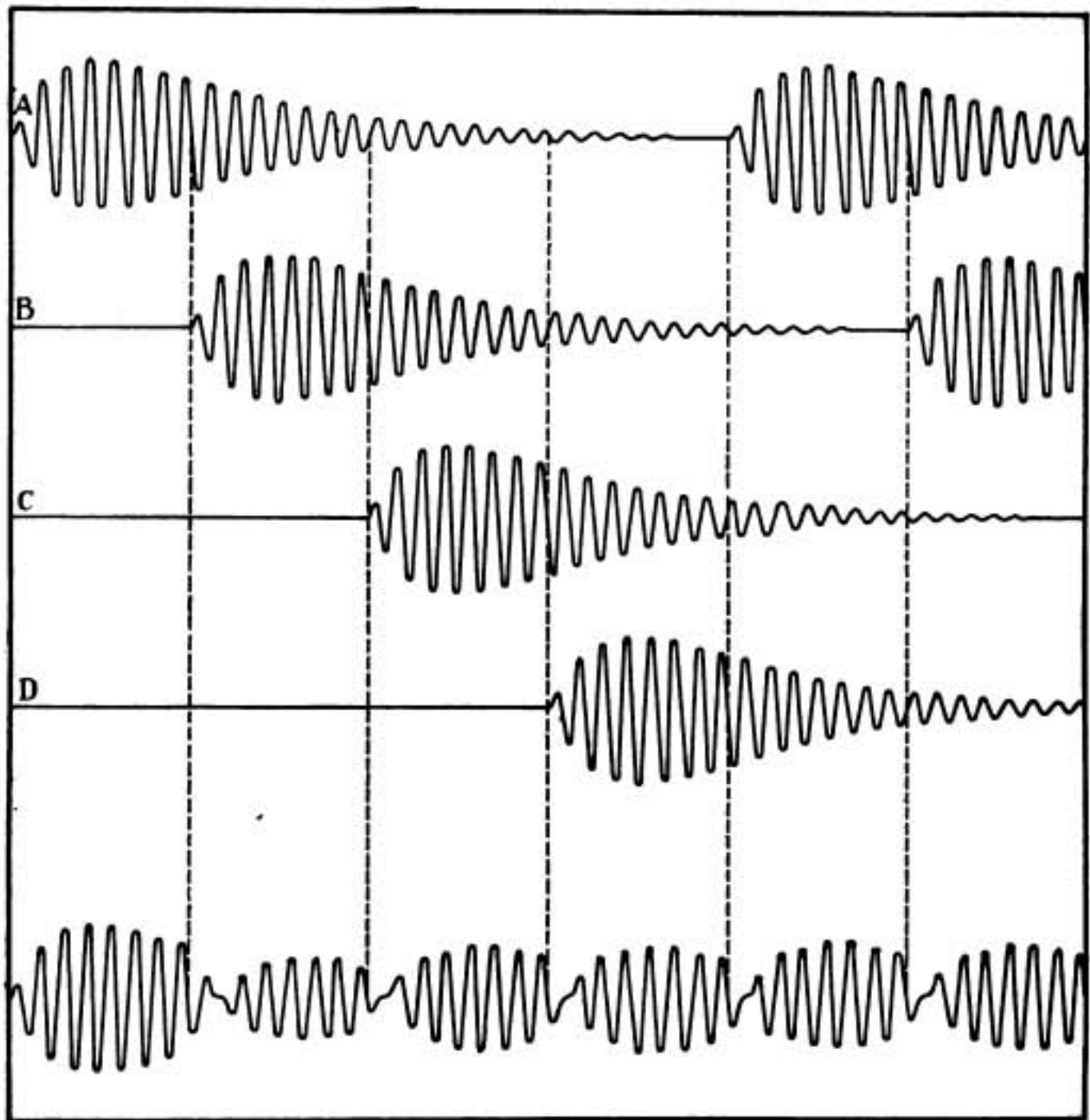

Fig. 2.

when using multiphase arrangements of the above type that the efficiency of the complete apparatus falls very considerably as compared with the value obtainable with one of the phases working alone. This is due to the irregularity in the synchronisation of the impulses and the consequent irregularity in the resultant wave form. These irregularities are also made manifest by the "hissing" that is heard in a receiver picking up the waves radiated from one of these sets.

The all-important feature of the Marconi continuous wave apparatus is the means provided for securing this correct synchronisation of the impulses, so as to ensure regular operation. A number of rotary disc spark-gaps are employed to provide the successive discharges in a similar manner to the multiphase apparatus discussed above, so that a high resultant discharge frequency is obtainable without increasing the spark frequency on each individual disc. The spacing of the teeth or studs on the discs

## THE MARCONI TIMED-SPARK CONTINUOUS WAVE.

is thereby retained at a reasonable figure to prevent the spark from flashing over to more than one stud at the same time.

Although the use of a rotary disc gap in place of a stationary quenched spark-gap provides much more regular operation and spark spacing, yet this alone is not sufficient to obtain the best results from synchronisation of the wave impulses, especially with high power sets. Means have therefore been provided with these installations for "timing" the main discharge to force it to commence at the correct instant of time in relation to the aerial oscillations. For this reason this apparatus is often referred to as the "Timed Disc Discharger."

The fundamental idea of the first forms of this apparatus was to employ several discs with a large number of studs, so that a fresh impulse could be imparted to the aerial circuit *once* in *every* oscillation. With high power sets working on long wavelengths this complication is unnecessary and a simpler arrangement using two main discs and one "trigger" or control disc is now employed. The general principle of the arrangement is illustrated diagrammatically in Fig. 3. The two main discs are shown at  $D_1, D_2$  and are each provided with four sets of fixed electrodes, connected so that each discharge circuit is formed with four spark gaps in series, two on each disc. As can be seen from the diagrams, the fixed electrodes are set so that the successive discharges occur on opposite sides of the discs, and pass through the two main oscillation circuits  $C_1, L_1, L_2$  and  $C_2, L_3, L_4$  alternately.

The timing of the main discharges is effected by the trigger disc TD which is driven by the same shaft as the main discs. This trigger disc is provided with twice the number of studs as the main discs in order that the trigger dis-

charges may be able to start off the main discharges on both sides of the main discs in succession. The trigger disc circuit is energised from the main supply generator G through the signalling key K. The trigger oscillation circuit  $C_7, L_7$  is coupled to a high voltage closed secondary circuit  $C_8, L_8$  which is tuned to  $C_7, L_7$ . From the terminals of this condenser, leads are taken through the quenching spark gap S to the central points of two pairs of small condensers  $C_3, C_4$  and  $C_5, C_6$  which are bridged across the main spark gaps as shown.

These condensers have a capacity of only about  $1/30$  that of the main condensers  $C_1, C_2$  so that very little of the main oscillation current would pass through them. The oscillation frequency of the trigger disc circuits  $C_7, L_7$  and  $C_8, L_8$  is made very much higher than that of the main oscillations so that the high frequency trigger discharge current can easily pass through the small condensers  $C_3, C_4, C_5, C_6$  to the discharging electrodes of the main discs. The trigger disc has only to deal with a very small power, so that the discharges are sharply defined.

The main spark gaps (of which there are four in series in each main discharge circuit) are about  $\frac{1}{16}$ " long, so that the voltage of the supply generator G (5,000 volts D.C.) is insufficient to break down the gaps. When, however, a spark occurs at the trigger disc, a high H.F. voltage is momentarily impressed upon the main discharge gaps, which are thereby ionised, so that the main discharge is suddenly precipitated.

In this way the main discharges can be spaced at perfectly regular intervals and exact synchronisation secured with the aerial oscillations.

An air blast is provided at each of the main gaps to rapidly quench out the spark after the first few oscillations.

All signalling for telegraphic working is accomplished in the trigger circuit, since the main discharges are completely controlled by this circuit. The signalling key has therefore only to handle quite a low power.

It should be evident from the above that the speed of the discs must be carefully adjusted and maintained constant if the desired exact synchronisation is to be maintained. Fig. 4 shows the Control Engineer's desk at the Radio Station recently erected at Stavanger, Norway, where indicators are provided to show the exact speed of the discs, and control handles for regulating this speed. In Figs. 5 and 6 are views of a 300-kw. C.W. installation of the type described above. Fig 5 shows the two main discs with the larger

trigger disc in the background on the right, while Fig. 6 is a view of the same installation taken from the trigger disc end. It should be noted from these photographs that the fixed electrodes are in the form of small revolving discs, to which the current is led by a number of flexible brush connections.

In the case illustrated, each main disc has 24 studs and the trigger disc 48, so that when one discharge has passed through the four gaps in series on one side of the discs, the next discharge will pass through the four on the opposite side at  $1/48$ th of a revolution later. The speed of revolution = 1982.5 r.p.m., so that 793 discharges per second occur

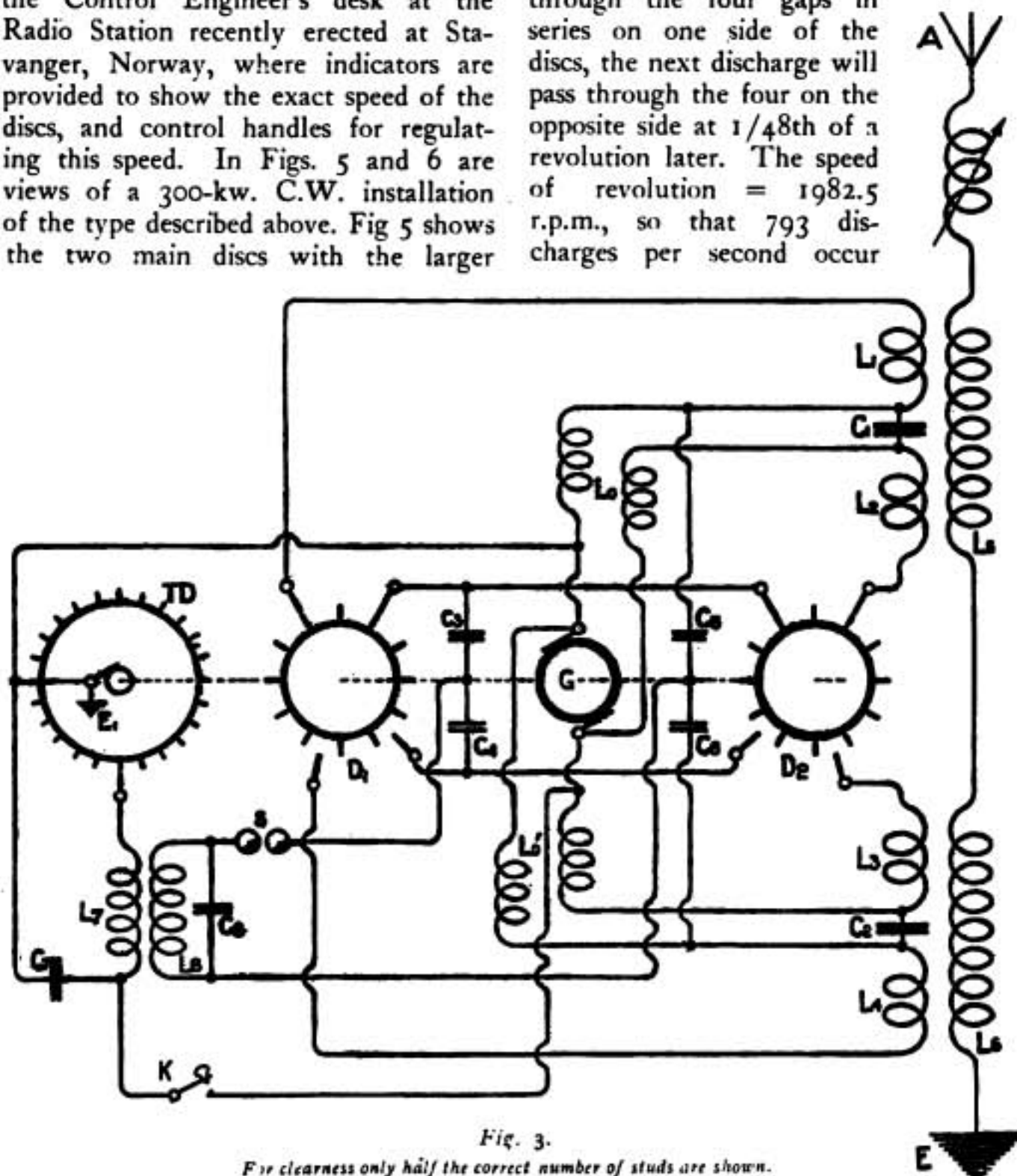

Fig. 3.  
For clearness only half the correct number of studs are shown.



THE MARCONI TIMED-SPARK CONTINUOUS WAVE.



*Fig. 4—The speed control for the discs.*

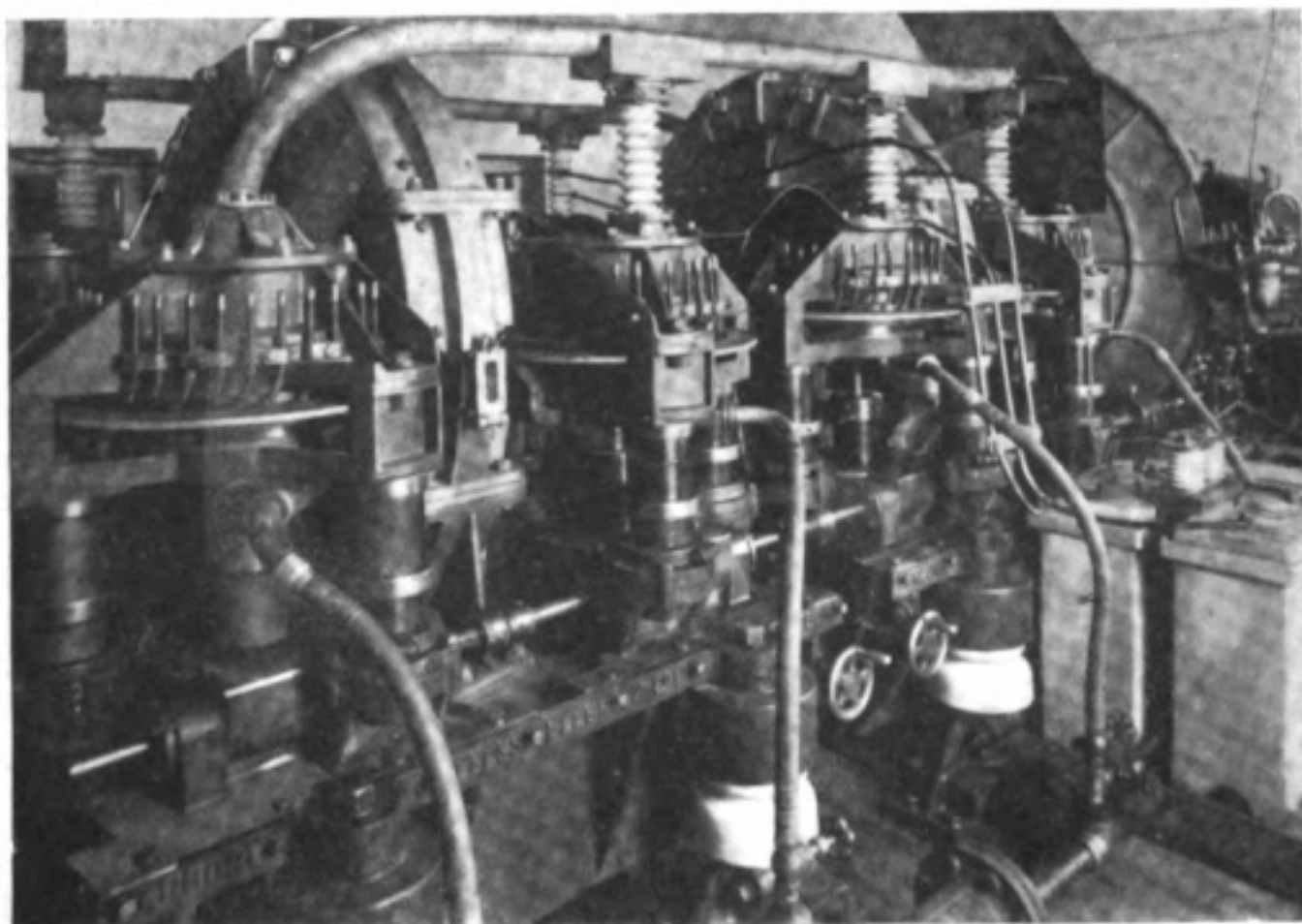

*Fig. 5—The "timed" discs at the Stavanger Station.*

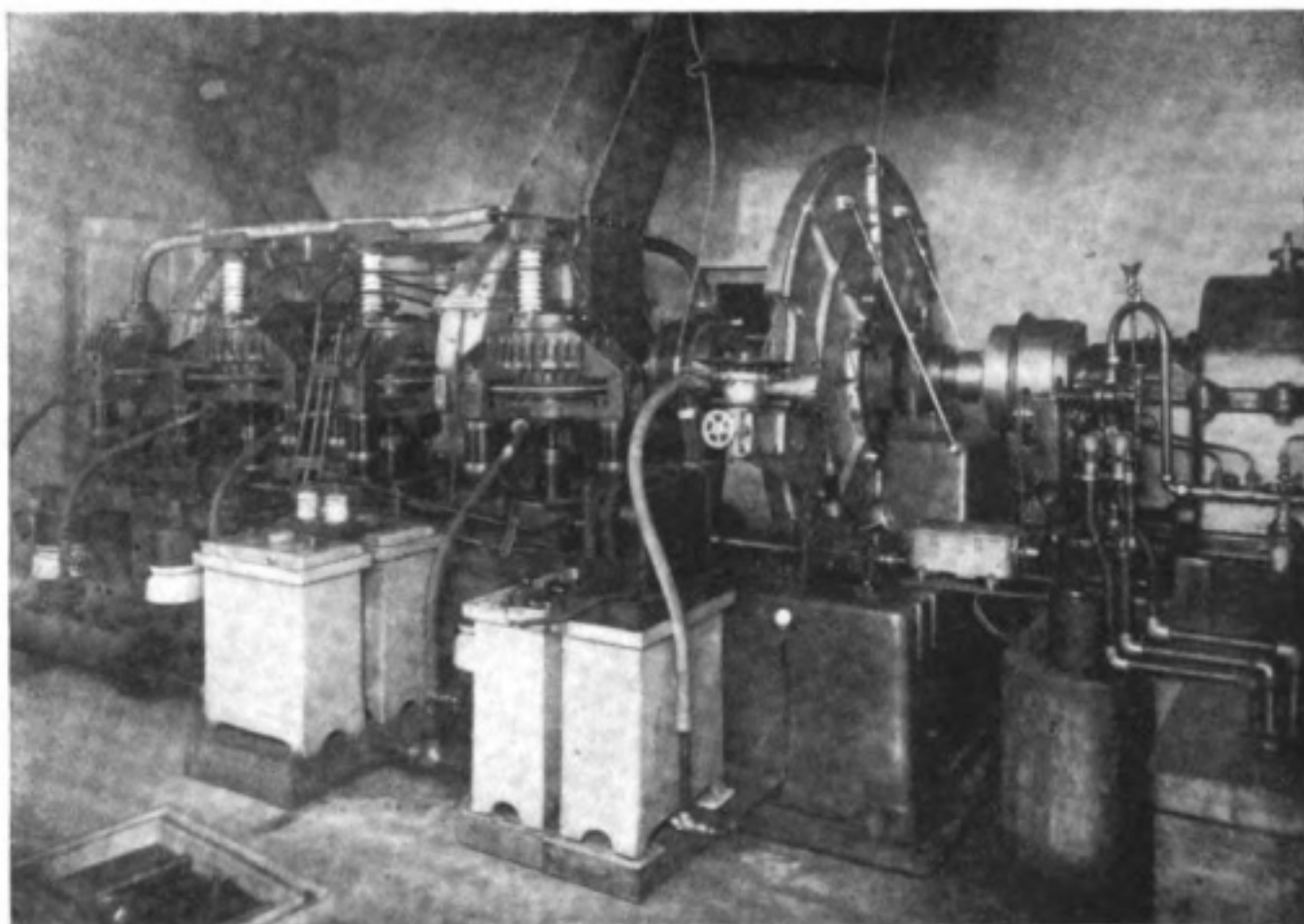

Fig. 6—Another view of the Stavanger discs.

on each side of the mains discs, making 1586 per second the effective sparking rate.

The main oscillation circuits and the aerial are tuned to a frequency of 21,400 ~ which corresponds to a wavelength of 14,000 metres. There are thus,  $\frac{21,400}{1,586} = 13.5$  oscillations

in the aerial between the commencement of successive discharges at the main gaps. Hence assuming, say, that there are four oscillations in the primary during each discharge, we have 9.5 oscillations in the aerial between the end of one discharge and the commencement of the next. Taking the decrement of the aerial circuit for the case of these large Marconi aerials as about 0.02, we find that with an oscillation frequency of 21,400 ~, the amplitude of the oscil-

lation will be reduced by the radiation and by the resistance losses, to about 82.5% of its initial value during these 9.5 oscillations. Hence it appears that in spite of the relatively long interval between successive discharges, the radiated wave is quite continuous, and only fluctuates a matter of about 13½% in amplitude.

The success of this simple method is evidently dependent upon the use of the very long wavelengths, since a spark frequency of 1586 would give quite a good note in the receiving telephones if used with short wavelengths, as there would then be such a large number of oscillations of the higher frequency between successive discharges that each wave train would die out almost completely before the commencement of the next discharge.

# Digest of Wireless Literature

By E. V. APPLETON, M.A., B.Sc.

## THE USE OF TREES AS ANTENNÆ.

IN the June issue of the Journal of the Franklin Institute, Major-General George O. Squier, the Chief Signal Officer of the United States Army, gives the results of some of the interesting experiments made during the war under his supervision. In 1904 this experimenter made some preliminary tests with a view to utilizing growing trees as antennæ for radio-telegraphy, but owing to the lack of a sufficiently sensitive receiver these experiments were only partially successful. In the later experiments carried out at Washington it was immediately discovered that with the sensitive thermionic valve receivers now available it was possible to receive signals from the principal European stations by simply laying a small wire netting on the ground beneath the tree as earth and connecting an insulated wire to a nail driven in the tree well within the outline of the tree top. After testing variations of earth and antennæ connections it was found that the best results were always obtained by using an elevated tree connection terminal in the upper part of the tree top and an "earth" consisting of several short pieces of insulated wire sealed at the outer ends radiating from a common centre and buried a few inches below the surface of the ground in the neighbourhood of the tree.

Experiments were performed testing the capacity and antenna resistance of such systems. The natural capacity was found to be proportional to the height of the contact with the tree. The antenna resistance was found to be many times that of an ordinary antenna, the range being from 2,000 to 26,000 ohms. Because of this high antenna resistance the design of the receivers had to be materially altered to utilize to the best advantage the energy impinging on the tree in the form of electromagnetic radiation, though it is stated that quite good results were obtained with receivers suitable for ordinary antenna. Miller has shewn that the presence of conducting material (e.g., a tree, buildings or wooden mast) near an antenna may increase the resistance of an antenna enormously, and it thus seems that the explanation of such large resistance values in the case of tree antenna is to be found in the effect of the immediate proximity of the partially conducting tree to the conducting lead. Some interesting quantitative experiments were made on the audibilities of

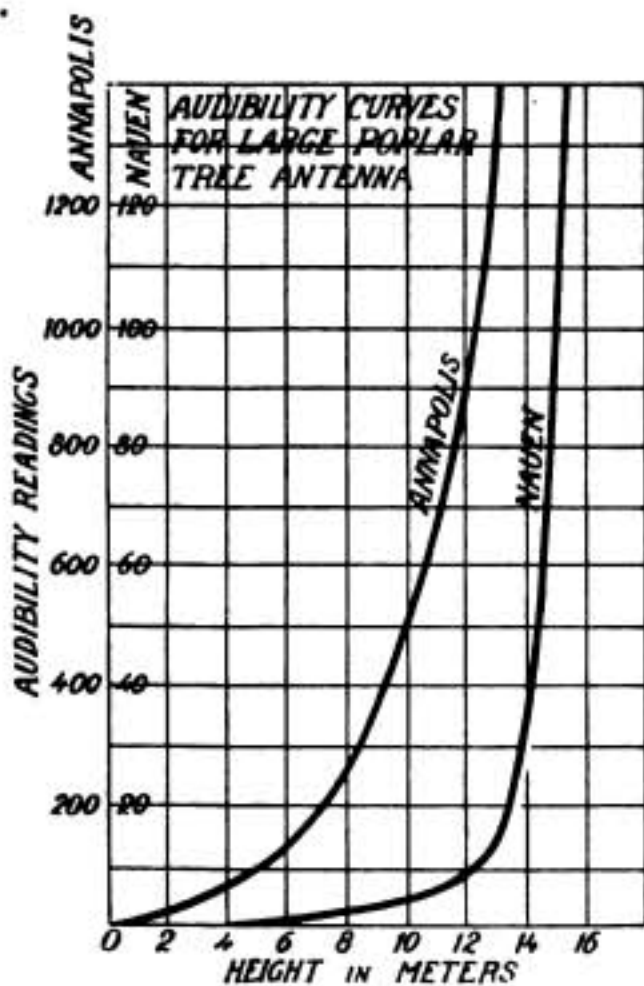

Fig 1

signals from Annapolis and Nauen. A non-inductive resistance was placed in parallel with the telephone and its value reduced until the limit of audibility was reached when dots and dashes could just barely be distinguished. If  $t$  is the impedance of the telephone for the particular frequency and  $s$  the resistance of the shunt in the final adjustment the ratio  $\frac{s+t}{s}$  gives the audibility.

A large poplar tree 18 metres high was used as antenna with a portable U.S.A. Signal Corps Heterodyne receiver and low frequency amplifier. The receiver set was in each case tuned to give best signal strengths and the audibility then found. The data obtained are illustrated by Fig. 1 in which audibilities are shewn as functions of the height of contact. It will be noted that a very great increase in audibility was found with heights of contact above two-thirds the height of the tree.

• • •

## THE DETECTION COEFFICIENT OF THERMIONIC VALVES

BY H. J. VAN DER BIJL.

Paper read before American Physical Society, March 1st, 1919.

**M**ANY workers with thermionic valves must have felt the need of a satisfactory method of comparing quantitatively the high-frequency detecting efficiencies of various types of valves. No reliable information can be got from a consideration of the curvature of the static characteristic curve alone, as in most practical cases the effects of grid current (e.g., with grid condenser and high resistance leak) are all-important. It thus seems preferable to have recourse to direct experiment and a simple method of doing this was described by H. J. Van der Bijl at a meeting of the American Physical Society on March 1st, 1919. The theory of this method can be best approached by a consideration of the fundamental relations between current and voltage in a thermionic valve. The magnitude of the plate current depends in general on the potentials of the plate and grid with respect to the filament. But when the valve is acting as a rectifier the relation between grid voltage and the consequent plate current variations (plate voltage being assumed constant) is non-linear. Thus if an alternating E.M.F. of maximum value  $v$  be impressed between the filament and grid the alternating changes in the plate current of maximum value  $I$  may be represented for practical purposes by the empirical relation—

$$I = a_1 v + a_2 v^2$$

where  $a_2$  is called the detection coefficient. When the valve is acting purely as an amplifier (i.e., working at conditions represented by the straight parts of the characteristic curve  $a_2$  is practically zero and the relation between plate current and grid voltage is a proportional one,  $a_1$  being the slope of the grid voltage-plate current characteristic.

For the determination of  $a_2$  under conditions approximating as nearly as possible to those of a wireless receiver alternating currents of radio-frequency and of small magnitude must be employed and thus the use of hot wire instruments

## DIGEST OF WIRELESS LITERATURE.

is out of the question. Moreover, it seemed preferable that the method of making comparison between the various signals should be a telephonic one. The apparatus used in the experiment of Van der Bijl is shewn diagrammatically in Fig. 2. The input voltage impressed on the tube at C ranged from a few hundredths to a few tenths of a volt and was measured by means of the Duddell galvanometer G frequency  $n$  with a variation of amplitude of audio-frequency  $n'$ . Mathematically the voltage  $e$  may be expressed by the relation:— $e = A \sin 2\pi nt (1 + \sin 2\pi n't)$ . With the change-over switch in position (a) a note of audible frequency  $n'$  is heard in the telephone. The current causing this note is too small to measure accurately by any instrument, but its magnitude can be arrived at by matching it with a known fraction of a much larger measurable current. This large current of audio-frequency  $n'$  is supplied by a generator U and its magnitude is measured by means of a thermo couple and micro-ammeter A. By means of the shunt S a known fraction of this current passes through the telephone when the switch is in (b)

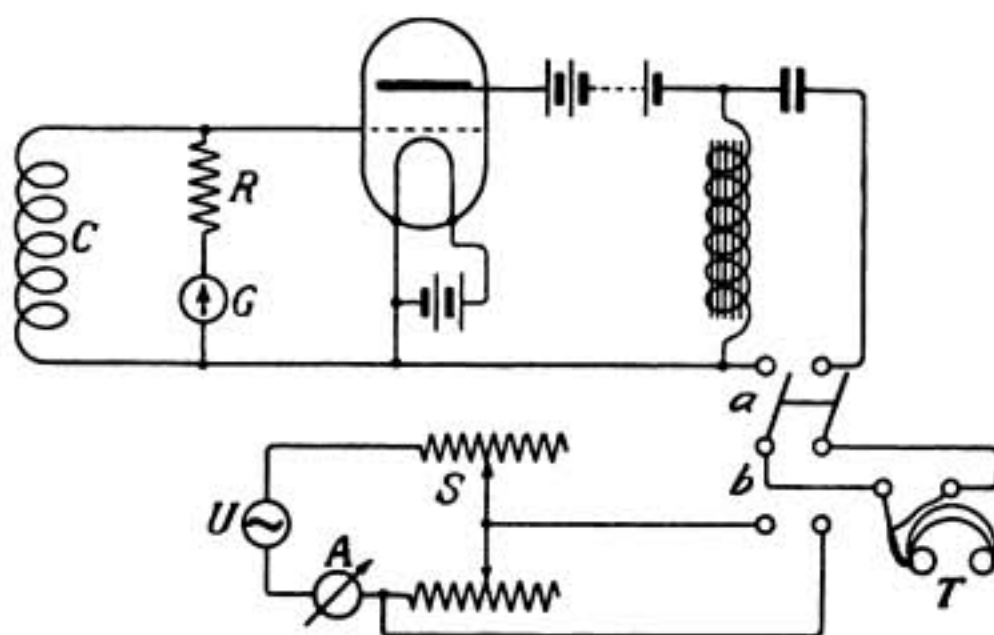

Fig. 2.

position. The shunt S is adjusted so that the signal intensity is the same for both positions of the switch. Thus in the equation  $I = a_2 v^2$  (the part  $a_1 v$  being neglected as it does not contribute to the detecting action of the valve) both  $I$ , the fraction of the current supplied by  $U$  and the input voltage  $v$  are known, and therefore  $a_2$  can be calculated.

It was found that similar results were obtained by two different observers in matching the two notes in the telephone. A certain valve in use for seven months was not found to alter in detecting efficiency to any noticeable extent during the whole period. The detection coefficient of this particular tube was found to be  $36 \times 10^{-6}$  amp/volts<sup>2</sup>, the resistance of the telephone receiver being 6,400 ohms. This corresponds to a power dissipation in the telephone of  $8.3 \times 10^{-6}$  watt/volts<sup>4</sup>. An idea of this amount of power in the receiver can be obtained by noting that the minimum power dissipation necessary in this particular receiver to give a sound that just barely enables one to distinguish signals is about  $3 \times 10^{-12}$  watts.

## THE NATURAL CONSTANTS OF WIRELESS ANTENNÆ.

A Meissner, *Physikalische Zeitschrift*, March 15th, 1919.

IN the *Physikalische Zeitschrift* of March 15th, 1919, A. Meissner gives a list of empirical formulæ for the determination of the natural wavelength of certain common forms of aerials. Taking the simplest case of an earthed vertical wire we may write  $\lambda_0 = 4l$  where  $\lambda_0$  is the fundamental wavelength of the unloaded aerial and  $l$  the length of the wire (see Fig. 3) (a). In the case of more complicated aerials formulæ similar to the above (i.e., always of the form  $\lambda_0 = Kl$  where  $K$  is a factor of proportionality) are available, the length as shewn in Fig. 3 always being the full length of the aerial, including the lead-in. For the same antenna capacity the greater the ratio of antenna capacity to antenna inductance the greater the factor  $K$ . An increase in the surface area of the antenna also leads to an increase in  $K$ .

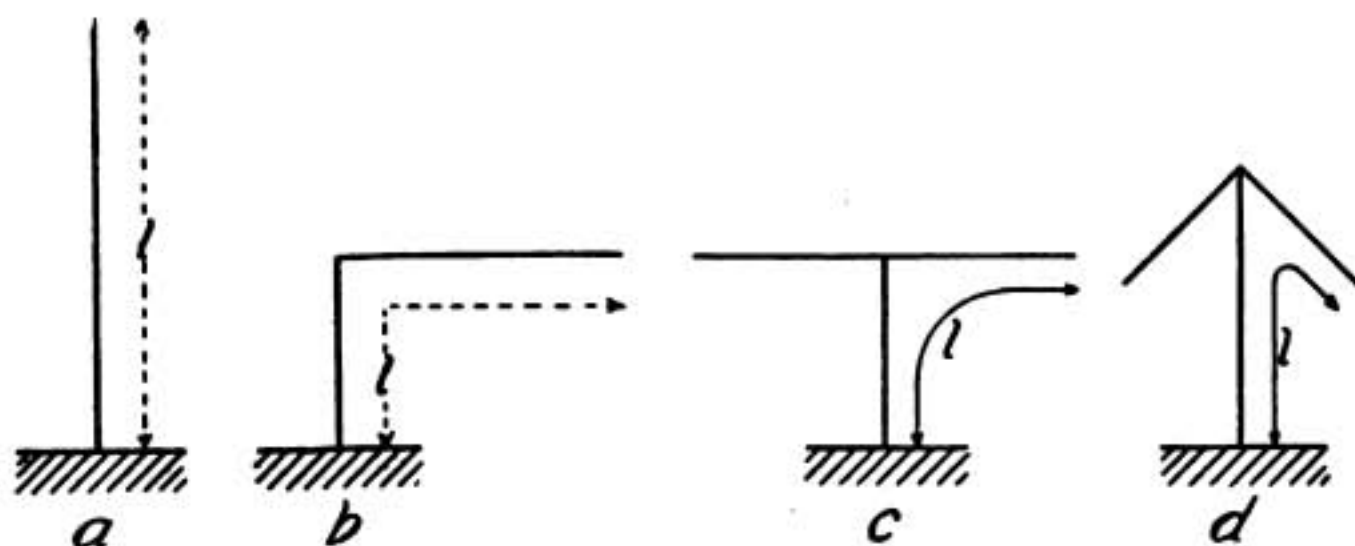

Fig. 3.

The following table gives the numerical values of  $K$  in relation  $\lambda_0 = Kl$  for various forms of antennæ:—

Γ-Antenna 1 metre from the ground	$K = 5$
Γ-Antenna with a breadth of $\frac{l}{2}$	$K = 5$ to 7
(e.g., for high Γ-Antenna at Nauen $K = 5.5$ )	
Narrow T-Antenna of a ship	$K = 4.5$ to 5
Broad Γ-Antenna (e.g., for T-Antenna at Nauen)	$K = 5.8$
Still broader T-Antenna (e.g., breadth = $l$ , height = $\frac{l}{2}$ )	$K = 9$
Ordinary Umbrella Antenna depending on the number of wires	$K = 6$ to 8
Low Umbrella Antenna (with height less than $\frac{l}{3}$ ) with many wires	$K = 8$ to 10

In the June issue of the Proceedings of the Institute of Radio Engineers J. M. Miller deals with the same subject in a less simple but more exhaustive manner. The aerial-ground portion of an antenna C.D in Fig. 4 is treated as a line with uniformly distributed inductance, capacity, and resistance. The lead-in is considered as being free from inductance or capacity except when inductances or condensers are specially inserted.

## DIGEST OF WIRELESS LITERATURE.

If  $L_1$  is the inductance per unit length,  $C_1$  the capacity per unit length and  $l$  the length of the aerial it can be shown that the fundamental frequency of the aerial is  $\frac{1}{4\sqrt{lC_1 \times lL_1}}$  (i.e.  $\frac{1}{4\sqrt{L_0 C_0}}$  where  $L_0$  and  $C_0$  are the total inductance and total capacity respectively). The wavelength in this simple case is equal to four times the length of the aerial. The wavelengths of the harmonic oscillations of the antenna bear in this case a definite ratio to the length (e.g., second harmonic  $\frac{1}{2}l$ , third harmonic  $\frac{1}{3}l$ ) and the harmonic frequencies are multiples of the fundamental frequency.

The most important practical case is, however, that in which an inductance is inserted in the lead-in. If the value of this be  $L$  the mathematical theory yields the relation  $\frac{\cot 2\pi n \sqrt{C_0 L_0}}{2\pi n \sqrt{C_0 L_0}} = \frac{L}{L_0}$  where  $n$  is the frequency of the natural oscillations of the loaded antenna. This equation cannot, however, be solved directly, but numerical tables can be constructed whereby the natural frequency  $n$  can be calculated when  $L_0$ ,  $C_0$  and  $L$  are known. (The reader will find these numerical tables in the paper referred to and also in Circular 74 of the Bureau of Standards obtainable from the Department of Commerce, Washington, price 60 cents.)

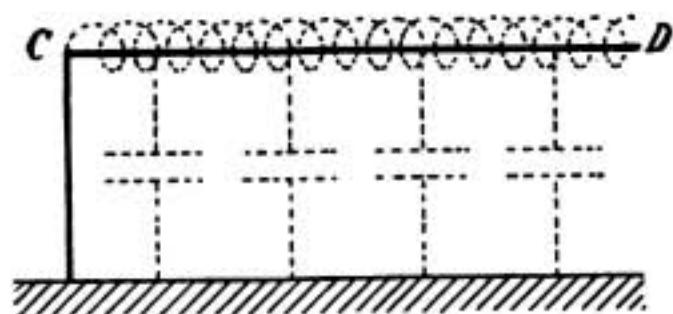

Fig. 4.

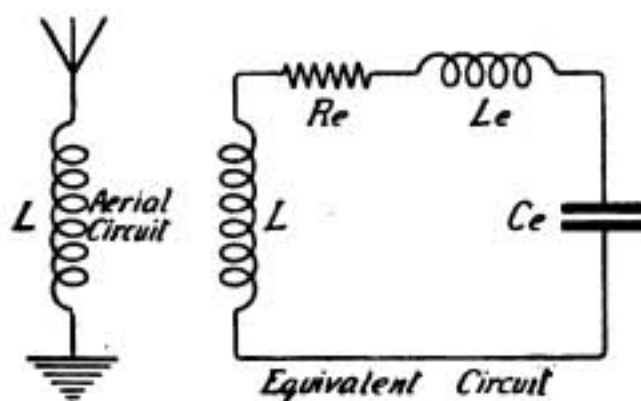

Fig. 5.

As an example of the method let the length of the antenna be 60 metres, the static capacity  $C_0$  be .0008 microfarads, and let the value of  $L_0$  equal 50 microhenries. If now an inductance  $L$  of 100 microhenries is introduced in the lead-in we have  $\frac{L}{L_0} = 2$ . From the table we find that when  $\frac{L}{L_0}$  is 2 we have  $\frac{2\pi l}{\lambda} = .653$ . Thus the wavelength may be calculated, and is found to be 577 metres. Thus introducing the inductance has increased the wavelength from 240 to 577 metres.

The case of a condenser of capacity  $C$  inserted in the lead-in can be considered in the same way. In such a case the relation between the natural frequency  $n$  and the other constants is  $-\frac{\tan 2\pi n \sqrt{C_0 L_0}}{2\pi n \sqrt{C_0 L_0}} = \frac{C}{C_0}$ .

Numerical tables can also be constructed for the solution of this equation. Thus in the above illustrative example if a capacity of .0005 microfarads is inserted in the lead-in the fundamental wavelength is shewn to be decreased from 240 to 172 metres. In quantitative wireless work it is very often necessary to replace an aerial with distributed capacity and inductance which also

has a loading coil  $L$  in the lead-in by an equivalent circuit consisting of the inserted inductance in series with lumped resistance  $R_e$ , inductance  $L_e$  and capacity  $C_e$  (see Fig. 5). In practice the quantities which are of importance in an antenna are the resonant wavelength or the frequency and the current at the current maximum. The quantities  $L_e$  and  $C_e$  are therefore defined as those which will give the equivalent circuit the same resonant frequency as the aerial circuit. Also a second condition is that quantities  $L_e$ ,  $C_e$  and  $R_e$  must be such that the current in the equivalent circuit will be the same as the maximum in the aerial circuit for the same applied E.M.F. whether damped or undamped oscillations are used. The mathematical work leading to the evaluation of  $R_e$ ,  $L_e$  and  $C_e$  is very complex, but the simple practical result which emerges is most useful. It is shewn that the effective low frequency resistance and inductance are each one-third of the values which are normally obtained by calculation considering the current as constant throughout the aerial, and that the effective low frequency capacity is the same as the capacity as calculated in the ordinary way.

We thus have:—

$$R_e = \frac{R_0}{3}$$

$$L_e = \frac{L_0}{3}$$

$$C_e = C_0$$

It is of interest to note that the two values for the effective inductance and capacity are in agreement with those obtained by an entirely different method by Prof. G. W. O. Howe in the Yearbook of Wireless Telegraphy and Telephony, page 699, 1917. The ordinary formula for the frequency of oscillation of circuits with lumped inductance and capacity may be applied in this case if we assume that the inductance and the capacity are the same at all frequencies, and we thus have to a high degree of approximation

$$\lambda_m = 1884 \sqrt{\left(L + \frac{L_0}{3}\right)C_0}$$

where  $\lambda_m$  indicates the wavelength in metres, inductance is expressed in microhenries, and capacity in microfarads. Applying this to the numerical example worked out above by the exact theory in which  $L + \frac{L_0}{3} = 116.67$  microhenries and  $C_0 = .0008$  microfarads we have  $\lambda = 575$  metres which differs only by one-third per cent. from the value 577 metres obtained before. It is, of course, possible to calculate  $C_0$  and  $L_0$  from the ordinary formulæ, but they may readily be determined experimentally if a standard wavemeter is available by the familiar method of determining the wavelengths  $\lambda_1$  and  $\lambda_2$  when two inductances  $L_1$  and  $L_2$  are separately inserted in the lead-in. It is easy to shew that in this case

$$L_0 = \frac{3(L_1 \lambda_2^2 - L_2 \lambda_1^2)}{\lambda_1^2 - \lambda_2^2}$$

The value of  $C_0$  can be obtained by substituting for  $L_0$  in either of the formulæ

$$\lambda_1 = 1884 \sqrt{\left(L_1 + \frac{L_0}{3}\right)C_0}$$

$$\lambda_2 = 1884 \sqrt{\left(L_2 + \frac{L_0}{3}\right)C_0}$$



## DIGEST OF WIRELESS LITERATURE.

The magnitude of the effective constants of an aerial circuit may also be determined experimentally if sources of both damped and undamped waves are available. When a source of undamped oscillations in a primary circuit induces an E.M.F.  $E_0$  in a secondary tuned circuit the current in the secondary depends only on the resistance  $R$  of the secondary and is given by  $\frac{E_0}{R}$ . If damped oscillations are supplied by the source in the primary the current in the secondary for a given E.M.F. and primary decrement depends upon the decrement of the secondary, i.e., upon the resistance and the ratio of capacity to inductance.

These facts suggest a method of determining the effective resistance, inductance and capacity of an antenna at a given frequency in which all of the measurements are made at one frequency.

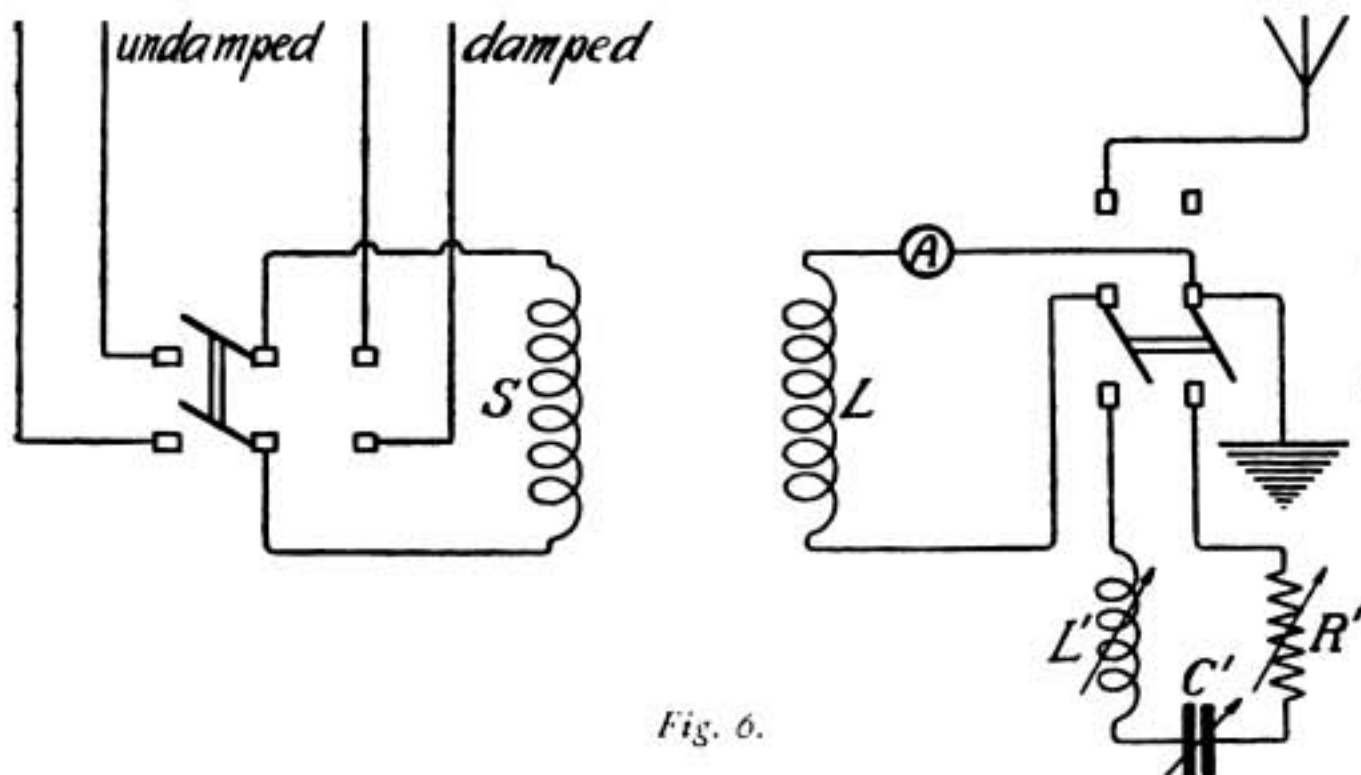

Fig. 6.

In Fig. 6  $S$  represents a coil in the primary circuit which may be thrown either into the circuit of a source of damped or undamped oscillations. The coil  $L$  is the loading coil of the antenna which may be thrown over to the measuring circuit containing a variable inductance  $L'$ , a variable condenser  $C'$  and a variable resistance  $R'$ . First, the undamped source is tuned to the antenna and then the circuit tuned to the source. The resistance  $R'$  is then varied until the current is the same in the two positions when  $R' = R_e$ . Next, the damped source is tuned to the antenna and the change in the current noted when the connection is thrown over to the  $L'C'$  circuit. If the current increases, the value of  $C'$  is greater than  $C_e$  and *vice versa*. By varying both  $L'$  and  $C'$  keeping the tuning the same and  $R'$  unchanged, the current may be adjusted to the same value in both positions. The effective capacity  $C_e$  is then given by  $C'$  and the effective inductance  $L_e$  by  $L'$ . The measurement requires steady sources of undamped and strongly damped current. The former is readily obtained by using a vacuum tube generator. A resonance transformer and magnesium spark gap operating at a low spark frequency serves satisfactorily for the latter source. An accuracy of one per cent is not difficult to obtain.

# Twice Across the Atlantic in Ten Days.

By LIEUT. R. F. DURRANT, R.A.F.,

*Wireless Officer of the R34.*

REMEMBER some years back, August, 1911, when the predecessor of the WIRELESS WORLD—the *Marconigraph*—first published details of the wireless on an aeroplane; it seemed to us then that wireless was reaching the climax of its wonderful history. Now only eight years later I wonder what you, students of the æther, will think of the last word in ætheric communication that lies behind the little door of the wireless cabin on H.M. Airship R.34—commanded by Major G. H. Scott, R.A.F. He has indeed demonstrated in a wonderful way the future of Rigid Airships by flying with a crew of 32 a distance of over 3,000 miles, landing safely, refuelling and returning to an appointed aerodrome in England, all in the space of ten days.

On R.34 there are four gondolas each with engine—the control car being forward and here the Commander, Navigator, and Coxswains are on duty—the latter controlling the rudder and elevators.

Just in the entrance between the engine unit and the chart table is the wireless cabin. It is approximately seven feet square and fitted with table, cupboards, and two windows. The aerial is provided by a long trailing wire beneath the ship, wound on a neat wooden reel and released when the ship attains a height of one thousand feet. The whole of the metal hull, cars, and

steel guys are used as the balance capacity.

For long distance transmission spark is not favoured owing to the danger of fire, and we use the now well-known system of undamped waves produced by the vacuum valve—to which is also attached a wireless telephone unit, capable of efficient speech up to 80 miles. For communication with merchant ships I used a small aircraft 100-watt transmitter, which proved very useful. In fact, never once did I call C.Q. when speeding along in that mysterious cloud world above the vast Atlantic, without receiving an answer from some ship, be she tramp or liner, all anxious to know of our welfare and progress.

When working the continuous wave transmitter great care has to be exercised to secure the maximum efficiency—and hence the valves particularly are carefully nursed to secure the best results. We worked St. Johns from a distance of 1,800 miles, receiving strength being good and clear. Surely the day is now coming when spark will make way for the silent continuous waves.

From England to New York not a ship was sighted until I got into wireless touch, and afterwards saw on our starboard bow the S.S. Seal outward bound for Australia. "GOOD, GOOD, O.M.," was what the Seal's spark crackled out and then "I've wasted six films on you, om." "Not wasted, I hope, om," I morsed out, and very aptly

## TWICE ACROSS THE ATLANTIC IN 10 DAYS.

he replied "Not for future generations, I hope."

Then came our worst experience, in the Bay of Fundy, with electrical disturbances. The good ship was taken out of our hands by an unseen power and hurled from 5,000 to 2,000 feet before answering the helm again, the air hot, and sparks leaping from the aerial as I

which was unfortunately misinterpreted in England as a distress signal; but the good ship sped on, and we reached New York under our own power.

The reception by the American authorities was one of the outstanding features of the flight; nothing was too much trouble for them, from providing clothes, to fêting us in "little old



*Lieut. R. F. Durrant, R.A.F.*

quickly reeled in, the whole atmosphere alive as with demoniac ferocity.

How the R.34 came through only Providence knows—but those who saw the wonderful handling by her Commander felt an inward thrill at his triumph over Nature. And then came the fear of petrol shortage, and the wireless call for U.S. destroyers to stand by,

New York." It indeed made us feel that a new tie had been created between the two great English-speaking peoples.

Much had to be done while on the ground, the sets overhauled and batteries recharged, although quite a lot of charging was done "en route" with a small charging board from the Brodt dynamo driven off the forrard engine.

Only four days there and the weather experts informed us we must leave that night as a great storm was coming from the region of the Great Lakes. We floated over New York at 1,500 feet and the sight that met our gaze is imprinted on our minds for ever; a veritable kaleidoscopic vision of light, interspersed with the searchlights of the United States battleships in the river, which shone now on our glistening hull, and then on the faces of the multitude below. It provided a scene which was almost intoxicating in its novelty.

Then the good craft's head was turned for the East, and with a 40-knot breeze behind us, and with only three engines running we were speeding to Blighty at 80 miles an hour. The cheery little meals in the crew space amidships, the chestnut of "who stirred the mustard with the toothbrush?" and the ragtimes on the Decca gramophone all showed the lighter side of the great flip, and when the giant masts of Clifden wireless station showed up against the evening sunset we all grinned broad grins.

I cannot conclude without thanking the Marconi Company for their magnificent help in placing their great Clifden and Glace Bay stations at our disposal; time and again the aerial cruiser was warned of bad weather ahead by wireless reports from Clifden, and their aid was of incaluable value. I wish to men-

tion, too, how Cape Race received my little spark set at 250 miles—which I believe creates a record. To Canso wireless station for great help and to all others who stood by so well, best thanks.

Whilst over Norfolk preparatory to landing, H.M. the King's gracious message came through and its effect when read on board was as a tonic. The lessons learnt on this voyage will enable Great Britain to maintain her supremacy of the air.

From the operating point of view the following items may be of interest. The High Tension voltage for the C.W. Transmitter was supplied by a very neat motor generator, specially constructed by Messrs. Newton, and giving a variation of voltage from 1,100-1,500 volts.

For long distance work we used a 3½-h.p. Douglas engine driving a larger motor generator situated in the engine room, this giving 2,000-3,000 volts.

The spark set worked on a 16 volt. battery which with a double pole switch could be used either for spark or lighting the filament of the valves.

A three-valve receiver was used for reception and with this Clifden was read right up to Nova Scotia—true note—and with the receiver oscillating, much further.

Severe atmospherics burnt two pairs of telephones out, and I have much to write on this at a later date.



*Corporal H. Powell.*

*Lieut. Durrant's assistant during the voyage.*

# Stray Waves.

## THE AMATEUR POSITION.

UNHAPPILY the situation in respect to amateur radio work remains unresolved, indeed the cancellation of all previously-existing amateur licences is a step backwards, although it may be the preliminary to a speedy settlement of the vexed question. This clean sweep of licences clearly shows that the Government has drastic alterations in view and intends to make an entirely fresh start. Anyhow, one seems to apprehend that the long-suffering amateur is doomed not to regain his pre-war footing.

To our way of thinking the wrong policy is being pursued. The wireless amateur should be encouraged, not shackled, restricted and shown the "cold shoulder." The country badly needs the brains of enthusiastic men who are prepared to follow up vital scientific subjects at their own expense and as a labour of love. The more minds there are applied in this country to the many outstanding problems of radio-communication the better, for young, keen America, painstaking Germany, and brilliant Japan are all in the field, to say nothing of Senatore Marconi's compatriots and those fine electricians, the French.

When war broke out the authorities were glad enough to avail themselves of the skill and experience of amateurs, and a shining example of what these amateurs are worth is that of Lieut. R. F. Durrant, the R.34's Wireless Officer, who was formerly a member of the North Middlesex Wireless Club.

We have before us a cutting from the *Daily Express*, a part of which

reads as follows, ". . . said an official of the General Post Office to a *Daily Express* representative, we are very careful to see that applicants are not simply out for amusement. Before the war we had a good deal of trouble with silly fools who apparently asked their best girls to tea and amused them by sending out 'S.O.S.' signals on their wireless sets. Now that there have been such improvements in the apparatus inanities of this kind will be very obstructive to messages of commercial importance."

All we have to say with regard to that statement is that any practical wireless man knows how the "fools" could be soon discovered and eliminated; no ban has been placed upon private motor-cars simply because a "fool" occasionally runs over a pedestrian. As for amusement, we should like to know why people may not amuse themselves in any way they please, provided they do not infringe the liberties of other citizens or transgress against the law. The amateur is willing to be supervised and to conform to reasonable regulations; he is even willing to act as a policeman of the æther amongst his own class, but judging from the look of things there exists a desire to obliterate him altogether. America has bowed—stiffly, it is true—to Prohibition, but she did not agree to the proposal to stifle amateur wireless telegraphy. Why should you? What are the Wireless Clubs doing to defend their rights? It was the American amateurs themselves who won their day, though they interested their legislators in the matter. Have our Wireless Clubs knowledge of any Member of Parliament who will stand up for them in the House?

### GERMAN INFLUENCE OVER DUTCH WIRELESS.

The Bandoen Correspondent of *De Locomotief* writes: If ever the history should be written again regarding the realisation of wireless telegraphic communication between the Dutch Indies and Holland and *vice versa*, thereby revealing the whole truth, one will then learn some very interesting details. We base this statement upon the fact that we have been successful in throwing some light upon the erection of radio stations in the Indies regarding which during the course of time we have collected material which shows clearly what a remarkable attitude the Dutch Government has taken up in this matter. It may be that in some points we are not fully accurate, but we shall, nevertheless, be successful in sketching in broad features a faithful picture of a portion of the original history of the wireless system mentioned above. The following is information which we have obtained from various sources:

When in the beginning of 1917 Dr. C. J. de Groot took his doctorate at the High School of Delft he stated in a paper the view that a direct wireless communication between the Dutch Indies and the Netherlands was to be regarded as a possibility. But there were few people who gave credence to that view. At that moment radiotelegraphy was not so far advanced as now and when people in Europe heard of the wireless station of German East Africa it was regarded as a fact of quite special importance.

Then it was that Herr Le Roy, the Director of the German Asiatic Telegraph Company, regarded it desirable to place himself in relation with Dr. de Groot and for this purpose he made a journey from Keulen, his headquarters, to the Hague for the purpose of making enquiries regarding the plans of our Engineer.

Firmly convinced that Germany would win the war, Herr Le Roy gave Dr. de Groot the advice, which, however, almost amounted to a command, to remain "in the German Line" (i.e., within the German sphere of action) in everything that he might undertake. It was from that moment that Herr Le Roy meddled with out wireless, very much to the disadvantage of the rapid realisation of this communication.

This gentleman's aim was to supplant the English cable monopoly by a hegemony of the Telefunken over our aerial system, which was certainly not in accordance with our intentions since we were striving for independence.

Herr de Groot proceeded to the Dutch Indies and immediately commenced activities, which in those days led to a very brilliant result. Through the Minister of the Colonies a sending apparatus was ordered in America which was installed at Malabar as early as November, 1917, and with which good results were obtained from the very first.

Herr Le Roy, however, did not relinquish his operations, and offered, in the name of the Telefunken Company, gratis, a time-sending apparatus destined for the Dutch Indies. It was well understood that Holland would be compelled to pay "through the nose" later on for this apparent gift.

The Telefunken apparatus arrived in the Indies by the warship "Zee-land" and the Governor did not feel wholly charmed with this little gift which was being fastened about our necks and by which an effort was being made to compete with Dr. de Groot. The latter should be afforded a good opportunity to succeed in his great enterprise and the Governor General is to be greatly praised for having allowed the installation to lie dormant for eight months at Soerabaja. It might perhaps have been there yet had not tele-

## STRAY WAVES.

graphic instructions been received from Holland insisting upon the installation of the (German) apparatus, failing which Germany threatened to stop the export of coal to Holland. The apparatus therefore received a place near the district capital of Tjililin, south west of Bandoen and received the necessary electric current from the B.E.M. from Dago, whence it was conveyed by high tension cable. The wireless at Malabar originally received its current from the same source, but it now has its own source of power, so that the sweeping away of the transformer house owing to the earthquake at Dago, did not affect it adversely.

There is still more mystery surrounding the radio station on Tjililin than that of Malabar. In the beginning we were only able to learn that Herr Moens, the Telefunken Agent, obtained control over a tractor of the military auto-service by which he was able to secure the transport of heavy cases which were addressed to Dr. de Groot, to the station of Tjililin, regarding which we have already written a short article. The new installation came under the supervision of Dr. de Groot, who as representative of the Government, had to exercise surveillance over his competitor.

German influence was, however, able to accomplish still more, and to this day has prevented the installation of a receiving station (i.e., in Holland) since it was argued that the Indies could signal their messages to Nauen.

Meanwhile there arrived in Holland as supporter to Dr. de Groot, Herr Dubois, who was not able to achieve much, but owing to his intervention he managed that the question should be examined somewhat more closely. Notwithstanding this Telefunken carried

the day and a definite installation was sent by a convoy, which, however, was discovered by the English and had to be unloaded. Then it was that the convoy had to return—officially it was stated that a consignment of paint of German manufacture had to be unloaded. The Minister, however, judged it necessary, in order not to spoil Telefunken's chances, to report that a Dutch wireless set, against the transit of which no objection could be raised, had had to be unloaded.

Now work is proceeding actively for the completion of both stations. Malabar is being made much more powerful and will reach 2,400 kilowatts, whilst the best French stations only use 1,500 kilowatts. Telefunken, however, is against this, and is only willing to go to 400. Luckily one is not holding entirely to that system since if it does not fulfill the demands made upon it, the contract will be broken. It will, however, probably be removed to Malabar, and on behalf of the Telefunken Company a power station is being built at Dajeub-Kolot, on the Tjitaroem, the building of which alone will cost the fabulous sum of three hundred thousand guilders.

• • •

## WIRELESS TELEPHONES ON JAPANESE LINERS.

Tokio papers state that wireless telephones are to be installed on the Toyo Kisen Kaisha passenger liners trading across the Pacific from San Francisco to Yokohama. Arrangements are also being made to connect up these steamers, when at sea, with the public telephone exchanges at Tokyo and Yokohama via the wireless apparatus. Ocean passengers will thus be able to speak direct to their friends at home.

## A Competition for Commercial Wireless Operators

**M**ANY of the problems of radio communication depend for their solution upon data collected by competent observers in all parts of the world. Given a mass of reliable information the scientist can attack it, trace laws or departure from laws, and probably arrive at a satisfactory hypothesis, but if he cannot travel widely, if he has at his disposal only facts relating to the particular part of the world in which he lives, he is badly handicapped. Before Darwin produced his epoch-making *Origin of Species* he spent twenty years in gathering data from naturalists, breeders, horticulturists and hunters in almost every country under the sun.

On page 331 of this issue there begins an article written by Dr. W. H. Eccles, who is well-known to most radio workers, in which he describes how wireless operators may render valuable assistance to those who make it their business to study the unsolved puzzles connected with wireless. The article has been written specially for the purpose of our competition and is intended as a guide to competitors as to the line of work to take up. The rest of the article will appear in our October number which will be published on September 25th. After having read the whole article make up your mind what work you can best perform and submit your results in the most suitable form, that is, as article, chart, schedule, curve, or list, or a combination of these.

(1) On the front cover of the Sep-

tember and October numbers will be found a coupon bearing the words, "W.W. Competition," and the name of the month. These coupons must be fastened to a covering letter containing the name and address of competitor, name of wireless station he is employed on, and the name of his employer; this letter must accompany the work sent in.

(2) Results are to be sent in an envelope or cover, marked "Competition," to the Editor, WIRELESS WORLD, 12-13 Henrietta Street, Strand, London, W.C.2.

(3) All manuscripts must be sent to the above address so as to reach it not later than January 7th, 1920.

(4) Manuscripts must be plainly written, one side only of the paper being used.

(5) No correspondence, either before or after the publication of the winners' names, can be entered upon.

(6) First prize, twelve guineas; second prize, six guineas; four consolation prizes, each consisting of Dr. Fleming's new book, entitled *The Thermionic Valve and Its Developments in Radiotelegraphy and Telephony*, and Mr. Philip R. Coursey's *Telephony without Wires*.

(7) The selection of the prize-winners will be made by Dr. J. Erskine-Murray and the Joint Editors of the WIRELESS WORLD, and the names of the successful competitors will be published in the WIRELESS WORLD for March, 1920.

(8) The decision of the editors shall be final.



# Wireless Telegraphy Problems for Operators

By W. H. ECCLES, D.Sc.

*This article has been specially written by Dr. Eccles for the purpose of showing intending competitors (see Competition described on p. 330) the fields which are open to them for research. The article is intended to be suggestive only, and competitors need not consider themselves necessarily bound to work on the lines indicated.*

**B**EFORE the war the British Association Committee for Radiotelegraphic Investigation had started a scheme of investigations of a kind that could be carried out by operators and amateurs, and had collected a great deal of information. Most of this was greatly affected by seasonal changes and many of the phenomena observed probably vary from year to year. But the scheme had not been in operation a full twelve months at the time the war broke out and stopped it. Consequently a great deal of the potential value of the work already done was lost. It is in the power of operators to resume a number of these investigations, though it is not yet certain that the B/A. Committee will again embark upon so comprehensive a scheme. The public-spirited enterprise now being initiated by THE WIRELESS WORLD promises to stimulate the prosecution of similar researches and to inaugurate others of a kind not possible to amateurs even if the amateur were at present free to begin work again. The professional operator is, apart from his opportunities for developing personal skill in the use of his apparatus, in a position of great advantage over the amateur in the respect that his station and his wireless gear form a very distinct, constant and full-size unit, such

as few amateurs can hope to possess. Besides this, the station of the sea-going operator moves about, and therefore affords excellent opportunities for the measurement of the variation of the strength of signals with distance and similar investigations usually beyond the reach of the amateur.

In attempting to give an outline of the experiments and investigations possible to the sea-going operator, it is necessary to fulfil the conditions that these shall not interfere with his traffic duties or involve derangements of his apparatus. Even with these limitations a great deal of most useful work can be done. In this article I need only refer to two classes of investigation, one directed to the study of the influence of natural phenomena on the propagation of signal waves, the other class dealing with the disturbances called variously "strays," "static," "atmospherics," or "X's."

## *Influence of Natural Phenomena on the Propagation of Signal Waves.*

Problems under this heading will usually be studied by observations on the variation of the strength of signals transmitted from some regularly-working station running under reasonably constant conditions. For example, time signals and press messages from the various high-power stations can be observed

regularly at fixed stations, and the effects of the phenomena mentioned below studied as regards their influence on the propagation of the waves. The sea-going operator, by similar observations, can hope to contribute to the establishment of the laws connecting distance and strength of signal from the same transmitting station. The natural phenomena principally concerned fall into two groups, one concerned with atmospheric action, the other with physical geography.

*Variations due to Atmospheric Actions.*

The most prominent of these are those due to the daily journey of the sun across the sky and, to a less extent, to the motion of the moon. The influence of the sun is enormous; the range of a station is far greater by night than by day and every sunrise and sunset brings about very striking phenomena. The atmosphere seems to be less transparent in the day than in the night and seems to be very opaque on occasion in the twilight band. Wireless experience taken alone suggests that ultra-violet or similar "ionising rays" from the sun give the air the property of absorbing the signal waves or of deflecting them; and from what is known of the action of such rays on rarefied gas, it seems likely that the layers of the atmosphere between 10 and 40 miles high are involved. At sunset these layers of the air begin to lose their property but other higher layers, apparently at a height of about 40 miles remain possessed of the deflecting powers and appear to act beneficially as reflectors of the wireless waves. Continuous observations of the times near sunset and sunrise when the change from day to night conditions takes place could not fail to be of help in the understanding of these facts.

Besides these regular variations there are the variations known as "fading." The cause of this is quite unknown and

is not likely to be discovered except by careful observing and recording of the facts. Probably the records obtained this way would have to be compared with the records of magnetic observatories, for the regular diurnal variations of the earth's magnetic field seem to be closely connected with the electrical conductivity of the layers of the atmosphere less than 50 miles above the earth.

There is evidence that the atmosphere at even less than 10 miles from the earth has its effect on signals. Clouds and moisture may have an influence and great storms such as tornadoes and cyclones certainly do. But it is very uncertain, still, whether the layers above 60 miles high come into play in wireless signalling either during the day or the night. The best way of settling this point is to observe, whenever possible, any effects apparently exerted by auroral displays. The aurora is never below about 60 miles, and as it is an electrical phenomenon, it may be expected to exert some influence on electric waves if indeed they go so high. Those observers who have the opportunity should therefore observe both long and short distance signals when an auroral display is in progress—perhaps in this way it might be settled whether waves from a far distant station travel to greater heights than waves from a relatively near station. In passing, it may be noted that all the great magnetic storms are associated with auroral displays, and the navigating officer on a ship usually knows when a magnetic storm is in progress. Such storms may last more than a whole day. They produce great disturbances in submarine and land lines, but no one has yet detected any influence on wireless.

*(To be continued.)*

*(The concluding portion of this article will be published in our October number on Sept. 25th. Competitors will thus have approximately three months in which to prepare their papers.)*

# Notes of the Month

## AIRCRAFT EXHIBITION AT AMSTERDAM.

Through the enterprise of the Dutch Government an Aircraft Exhibition was opened at Amsterdam on August 1st, at which most of the leading British Aircraft Manufacturing Firms are exhibiting. Marconi's Wireless Telegraph Company, Ltd., show their standard Transmitting, Receiving and Direction-Finding Sets for Aircraft, as well as a certain amount of Field Station Apparatus. The most interesting feature of the Marconi Company's Aircraft exhibits is the new 100-watt Aircraft Telephone Transmitter. This set has a range from air to ground of from 80 to 100 miles, using 70 feet masts and a standard three-valve receiver on the ground. The Direction-Finding Apparatus displayed is of a similar type to that supplied to the transatlantic Handley-Page machine which gave such successful results on the voyage of that machine from Newfoundland to Nova Scotia. In addition to the apparatus shown on the Stand there is a standard Telephone Ground Transmitting Station in the Exhibition Grounds, and arrangements have been made for practical demonstrations of both the Direction-Finding and Telephony Sets for air to ground and ground to air communication. This means that passengers taking trial flights will be able to talk with their friends on the ground, and *vice versa*.

• • •

## REMOVAL OF CENSORSHIP.

The censorship was abolished, so far as British controlled cables and wireless

telegraphs are concerned, from midnight on July 23rd-24th. Telegrams will now be accepted without restriction to all British possessions, to the United States and Possessions, and generally to all parts of the world, with the exception of the following countries in which restrictions have not yet been abrogated by the authorities concerned:

Germany, Austria, Hungary, Bulgaria and Turkey (including Palestine, Syria and Mesopotamia), France and French Possessions, Greece, Roumania, and Kingdom of Serbs, Croats and Slovenes, Czecho-Slovakia and Poland, Finland, Esthonia, Lithuania, Russia (including Caucasus and Russia in Asia), Norway, Sweden and Switzerland, Japan, Honduras, Argentina.

The Postmaster-General is in communication with the Administrations of these countries, and a further announcement will be made when the existing restrictions on telegraphic correspondence with any of them are abolished.

• • •

## MARCONI'S WIRELESS TELEGRAPH CO., LTD., v. THE POSTMASTER-GENERAL.

On July 25th, Mr. Justice A. T. Lawrence delivered his award in the arbitration proceedings between the above-mentioned parties. In awarding the Marconi Company £590,000, he said, "I only want to say with regard to it that that is my estimate of the present worth of all the royalties the Company would have recovered under the contract. I have excluded from consideration, as by order directed, the letter of January 1st, 1915, and I have not diminished the amount by any con-

sideration of the probability or otherwise of Marconi patents being employed in commercial wireless in the future."

• • •

**THE MARCONI WIRELESS  
TELEGRAPH CO. OF  
AMERICA, v. THE ATLANTIC  
COMMUNICATION CO.**

Judgment has been obtained by the first-mentioned firm in its action, the subject of which was the use of the audion, which was held to infringe the Marconi Co's. Fleming patent of Nov. 5th, 1905. The Atlantic Communication Co. before the war operated the notorious station at Sayville.

• • •

**THE NEW WIRELESS TELE-  
GRAPHY BILL.**

Lord Somerleyton's Merchant Shipping (Wireless Telegraphy) Bill, which requires every passenger and cargo steamer of 1,600 tons and upwards to be equipped with wireless telegraphic apparatus, has passed the third reading.

• • •

**WIRELESS CLUB NOTES.**

**THE WIRELESS AND EXPERIMENTAL  
ASSOCIATION.**

The Amateur Wireless Alliance, late of Peckham Rye, S.E., has been re-organised under the name of the Wireless and Experimental Association, with headquarters at 16, Peckham Road, Camberwell, S.E.

Mr. F. H. Gribble, 48, Surrey Square, Walworth, S.E., has been appointed Secretary, and will be glad to see any visitors at the Club's headquarters any Wednesday evening at 7 o'clock.

A strong committee has been drawn together, and London readers will no doubt find many of their old wireless and experimental friends attached to this new Association.

**THREE TOWNS WIRELESS CLUB.**

*July 3rd.*

A Morse practice was followed by a general discussion. A member suggested an exhibition of home-made apparatus, and this will probably be arranged soon. A feature of the evening was the reading of some translations from an American Amateur Wireless Journal.

*July 9th.*

The Club met at the Plymouth Chambers. Mr. J. Jerritt presided. Mr. Lock, one of the members, gave an instructive lecture dealing with inductance, capacity, and tuning as applied to Wireless Telegraphy.

*July 17th.*

Mr. Jerritt presided. Mr. Voss lectured on the "Difficulties likely to be encountered by Amateur Wireless Men," dealing more especially with receiving circuits and their construction, also the difficulties encountered in erecting efficient aerials in a small space.

*July 24th.*

Mr. Jerritt presided. Mr. Lock gave a most interesting lecture on "My First Wireless Apparatus," starting on the coherer and bell, and working up to his pre-war instruments. Some interesting sketches of his proposed C.W. set were shown and explained.

The Club will be pleased to welcome visitors and to enrol new members. All communications should be sent to W. Rose, Hon. Sec., 7 Brandreth Road, Compton, Plymouth.

• • •

**NORTH MIDDLESEX WIRELESS CLUB.**

The 21st meeting of the Club was held at Shaftesbury Hall, Bowes Park, on July 15th. In spite of a number of the members being on holiday there was a very fair attendance, and the meeting was quite a success.

The first part of the evening was devoted to the business of electing the Officers of the Club for the year. The

## NOTES OF THE MONTH.

President, Mr. A. G. Arthur, and the Hon. Secretary, Mr. E. M. Savage, in accordance with the rules of the Club, retired automatically at the end of their year of office, and were eligible for re-election.

Mr. Arthur was then again proposed as President by Mr. Midworth and seconded by Mr. Green, and there being no other member proposed for this office Mr. Arthur was duly elected.

Mr. Savage was again elected as Secretary, and Messrs. A. W. Hulbert, L. C. Holton, and W. Gartland offered themselves to serve on the Committee, and were duly appointed.

The President, in the course of his remarks, which by their dry humour are always keenly appreciated by the members present, drew attention to the fact

that the Wireless Officer on board H.M. Airship R.34, Lieut. R. F. Durrant, was a member of the Club, and up to the outbreak of War had served on the Committee and had always been a live member. Before joining the forces his work was in no way connected with Wireless or Electricity, but the knowledge gained in pursuit of his hobby had enabled him to take responsible positions in the Wireless Service. Mr. Arthur said that he was sure the members would feel proud that a member of the North Middlesex Wireless Club was numbered among the officers of the R.34.

Particulars of the Club may be had from the Hon. Secretary, Mr. E. M. Savage, "Nithsdale," Eversley Park Road, Winchmore Hill, N.



Photo by

Herbert F. Baldwin.

*Mercantile Wireless Telegraphists in the Thames Pageant, August 4th, 1919,  
Their boat is the one immediately behind the Tug.*

# The Victory March

**W**HEN, on July 19th, a representative body of the Empire's forces marched through London in celebration of peace and victory, twelve wireless operators of the Mercantile Marine took a well-merited part in the procession. These men and their colleagues shared equally with seamen the risks of keeping the seas, and in very many cases paid

with life and limb the price of duty faithfully done. Even after repeated torpedoings they did not hesitate to go yet again into the danger zones strewn with mines or infested by German submarines, and what the Empire owes to them can be neither calculated nor paid for. We have much pleasure in reproducing a photograph of nine of the gentlemen who took part in the march.



Photo by

Topical Press.

Standing (left to right)—S. A. SORRELL, E. A. WATKINSON, M. FRAWLEY, C. H. DURRANT.

Inset (top)—W. S. SUTHERLAND, H. STURDY, H. E. MULLEY.

Inset (bottom)—F. J. H. BLIGH, A. DINSDALE.

# The Theory of Valve Rectification

By W. S. Barrell.

(Continued from August Number.)

## GRID CURRENTS.

**I**N our study of the elementary principles governing rectification by the three-electrode valve, we have, up to the present, only considered one class of curve, namely, that produced by plotting the current in the anode circuit against grid voltage. So far we have been chiefly concerned with the anode current, any currents which might flow in the grid-filament circuit having been neglected.

It will now be necessary to consider the phenomena taking place in the latter circuit, for, as will be shown, under certain conditions currents will flow which have an important bearing on rectification. Whether the current in the grid circuit flows continually in one direction or whether after a time it changes in direction will depend upon certain points which will be discussed later.

The first point for consideration is, what is the effect, if any, on the grid current when the potential of the grid is varied, and this can most easily be studied from a curve in which grid current is plotted against grid voltage.

A circuit should be set up as shown in Fig. 10, which is essentially the same as that utilized for obtaining the grid voltage-anode current characteristic, but with the addition of a micro-ammeter *Ma* inserted in the grid-filament circuit. Using the scheme of connections shown in the diagram it becomes quite easy to take the readings for the grid current and anode current curves simultaneously should both be required.

It was mentioned above that under certain conditions the grid current might

change in direction, and therefore it is preferable that the zero position of the micro-ammeter needle be adjusted to somewhere near the centre of the scale.

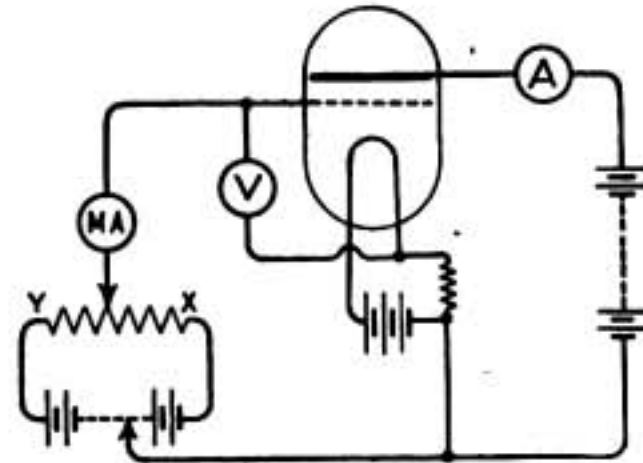

Fig. 10.

This condition will cover the case of all valves whether hard or soft, but at the moment, we shall continue to deal with hard valves only, and for these it is not so necessary that this adjustment be made as all the readings will be in one direction. The advantage of the central zero will be shown when dealing with soft tubes.

Referring to Fig. 10, the voltmeter, *V*, will indicate the potential of the grid with respect to the negative end of the filament and, as this may be either negative or positive, an instrument with a central zero is advocated. The ordinary voltmeter could of course be used, but then the leads would have to be reversed when changing from negative to positive values and vice versa. The anode current is measured by the instrument *A*, and the readings of *Ma* will show the current and its direction in the grid circuit. Commencing then with the potentiometer slider at *X*, readings of all instruments should be taken at, say, every half volt (as recommended when

taking the Fleming Valve curve\*) until the slider is at Y.

Three sets of figures will thus be obtained: (1) Values of grid voltages; (2) Anode current; (3) Grid current, and the curves may be plotted as shown in Fig. 11, A and A<sub>1</sub>. As the grid currents are so much smaller than the anode currents the curve A<sub>1</sub> has been drawn to a larger scale.

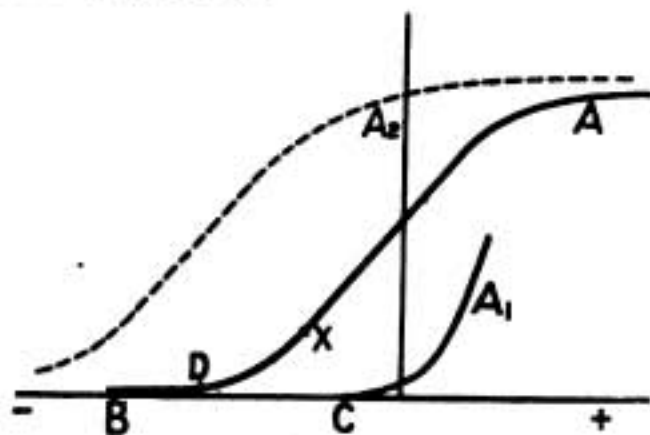

Fig. 11.

A study of these curves will reveal several interesting facts. First of all, it will be noticed that the anode current commences much earlier than the grid current, and in fact reaches a comparatively high value before a current starts in the grid circuit. Secondly, it will be seen that from B to C a current is flowing in the anode circuit, but not in the grid circuit. Thirdly, the grid current curve has a sharp bend somewhat similar to the bend in the anode current curve. The dotted curve A<sub>2</sub> has been added to show the effect of increasing the anode voltage. The curve is seen to be raised vertically, but it should be noted that the grid current curve is practically unaffected by the increase in anode voltage.

#### GRID CURRENT AS AN AID TO RECTIFICATION.

The method of using the valve as a rectifier working at the bend of the anode characteristic, D Fig 11, has already been considered and it is now sup-

posed that the grid potential is increased so that normally the valve is working at the point X Fig. 11. The slope of the curve at this point is much greater than at the point D, and therefore it follows that any given voltage variation on the grid will now give a greater variation in anode current. It is to be noticed, however, that we are now working on the straight part of the curve, and at first sight it would appear that, from the effect of an incoming oscillation, the increase in anode current due to the positive half waves would be exactly equal to the decrease due to the negative half waves. It follows that under these conditions the normal current through the telephones would remain unaltered, and no signal would be heard. A further reference to Fig. 11 shows that normally the grid potential is at such a value that the grid current is zero. The negative half waves will reduce the potential of the grid and consequently the current in the anode circuit, but the positive half waves will increase the grid potential to the point at which a current flows in the grid circuit. Let us consider this action a little more closely. The circuit is shown in Fig. 9\* from which it is seen that the oscillatory circuit is shunted by the grid and filament circuit of the valve. When the grid assumes its normal potential no current flows in this circuit and the resistance of the shunt is infinite. When a current flows in the grid circuit, however, the resistance of this shunt falls and since the damping of the oscillatory circuit depends largely upon the value of the shunted resistance, the latter may fall sufficiently low to damp out the positive half waves. In this way the variations in the anode current will not be equal on both sides of the point X, and in fact will be much greater for the negative half waves. As

\* WIRELESS WORLD, July, 1919, p. 182.

\* WIRELESS WORLD, August, 1919, p. 246.



## THEORY OF VALVE RECTIFICATION.

the effect of these is to decrease the anode current the mean value will be reduced, and consequently a signal will be heard in a telephone connected in the anode circuit. We may thus look upon the oscillatory circuit as being shunted by a variable resistance (the value) which varies from infinity to a comparatively low value.

### CUMULATIVE RECTIFICATION.

The circuit shown in Fig. 12 will now be considered and should be compared with that shown in Fig. 9\*. It will be noticed that the grid potentiometer has been omitted, the lead from the lower end of the oscillatory circuit being connected direct to the positive end of the filament battery. Further,

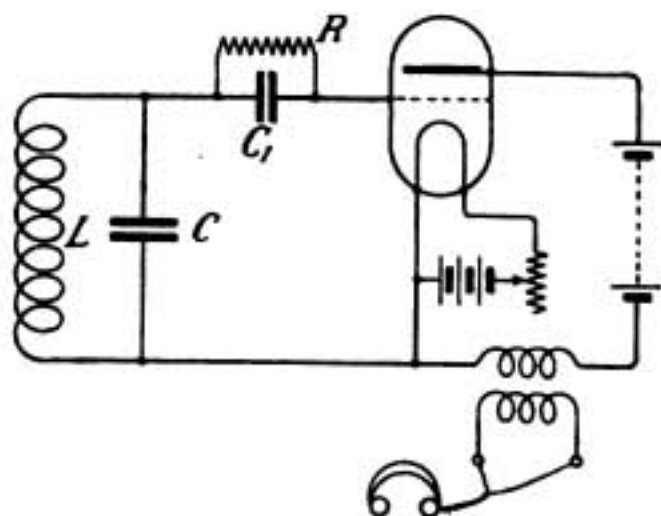

Fig. 12.

in the lead to the grid a small condenser  $C_1$  has been inserted which is shunted by a high resistance  $R$ . Suppose this circuit to be coupled to a suitable aerial system. An incoming wave train will produce oscillations in the circuit  $LC$  which are rectified between the filament and grid of the valve. The rectified current will charge up the condenser  $C_1$ , the side connected to the grid receiving the negative charge. This will be readily understood, remembering that electrons are minute negative charges. The negative charge thus produced on

\* WIRELESS WORLD, August, 1919, p. 246.

the grid decreases the flow of electrons to the anode. In consequence a reduction of current in the telephones connected in the anode circuit takes place and a signal is heard.

It has been shown that the effect of a wave train is to impart a powerful negative charge to the grid, and before the valve is in a condition to detect any subsequent wave train this negative charge must be neutralized, thus allowing the potential of the grid and consequently the anode current to resume their normal values.

In hard tubes such as we are considering there is so little gas present that the charge cannot leak off through the tube and the necessity of the grid leak becomes apparent. When the oscillations cease a current from the filament battery flows through the resistance  $R$ , neutralizing the charge on the grid. The valve re-assumes its normal state and is then ready to detect the next wave train. The cumulative effect of a wave train causes a signal in the telephones by decreasing the anode current which, by the action explained, rises to its normal value at the end of the train.

As soft valves are now but little used only a very brief explanation of some of the more important phenomena will be given.

In Fig. 13 is shown the grid current curve of a soft valve. Comparing this with curve  $A_1$  Fig. 11, a very striking difference will be noticed. In the case of the hard tube the curve is entirely above the horizontal axis, but in the case of Fig. 13 it will be seen that part is below. In the latter case the microammeter  $Ma$  (Fig. 10) first gave a deflection in one direction which increased up to the point  $A$ . It then decreased to the point  $B$  where it changed sign. That part of the curve above the axis of  $V$  denotes a current from the filament

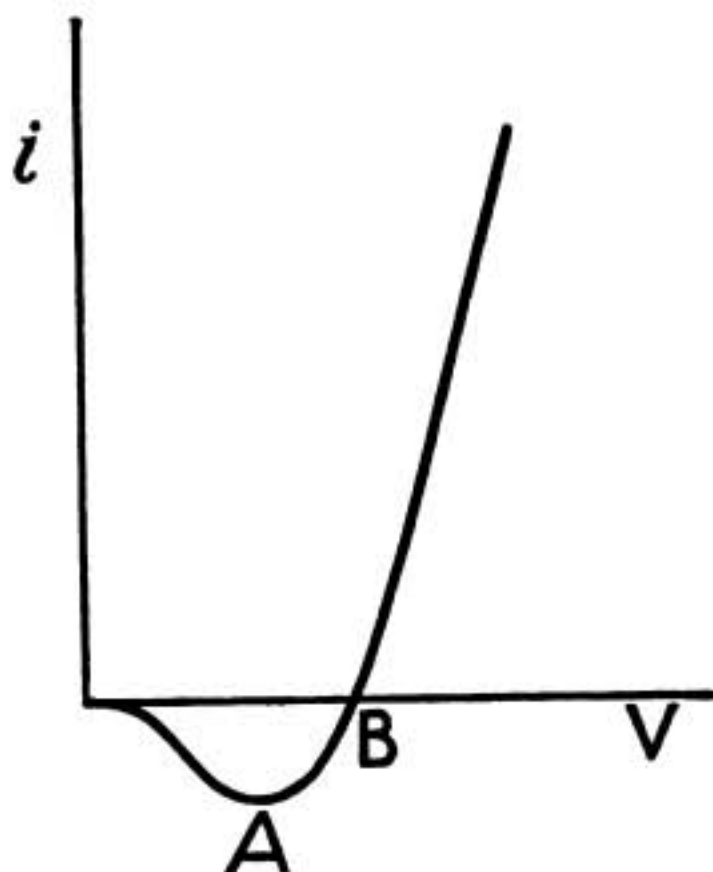

Fig 13.

to the grid, and that below the  $V$  axis is a measure of the current flowing from the grid to the filament. The fact then that the curve in Fig 13 is partly below the horizontal axis shows that for potentials up to  $B$  the grid receives more positive than negative electricity through the valve. This can be shown as follows: When studying the phenomena of hard valves the moving electrons only had to be considered, but in tubes containing gas the effect of the positive ions

has to be considered in addition to the electrons. By reason of the anode potential the electrons will travel at the highest speed in the space between the grid and the anode. The valve being soft, the swiftly moving electrons will ionize the gas, that is, will split up the molecules by collision into positive ions and electrons. Due to the attraction between unlike charges, the positive ions will move towards the filament, the newly formed electrons joining the original electron stream to the anode. Some of the positive ions will, however, be intercepted by the grid which may therefore receive more positive than negative electricity as shown by the curve, Fig. 13.

For a given high tension anode voltage the softer the tube, i.e., the greater the number of gas molecules, the greater will be the dip below the axis of  $V$ . It can further be shown that provided the pressure of gas be constant the position of the bend in the curve depends upon the filament temperature and the potential of the anode.

If the anode potential is too high for the valve the positive ions will entirely neutralize the space charge; the electron flow to the anode will be very heavy and a violent blue glow seen in the tube. In this condition the valve is very insensitive as the control by small voltage changes on the grid is lost.

## WIRELESS AND THE INTERNATIONAL COMMISSION FOR AIR NAVIGATION.

*The following is an extract from the regulations framed by the International Commission for Air Navigation:—*

Wireless apparatus must not be carried without a special license issued by the State whose nationality the aircraft possesses, but every aircraft used in public transport and capable of carrying ten

or more persons shall be equipped with sending and receiving wireless apparatus when the methods of employing such apparatus shall have been determined by the International Commission for Air Navigation.

The Commission may later extend the obligation of carrying wireless apparatus to all other classes of aircraft.

# Aircraft Wireless Section

Edited by J. J. Honan (late Lieutenant and Instructor, R.A.F.).

*These articles are intended primarily to offer, as simply as possible, some useful information to those to whom wireless sets are but auxiliary "gadgets" in a wider sphere of activity. It is hoped, however, that they may also prove of interest to the wireless worker generally, as illustrating types of instruments that have been specially evolved to meet the specific needs of the Aviator.*

## AIRCRAFT WIRELESS SETS.

### THE NO. 1 TRANSMITTER— (Continued).

#### Fittings and Accessories.

#### THE FAIRLEAD.

This consists of a metal tube (Fig. 15) with an insulated top portion fitted into the floor of the nacelle and forming a guideway for the aerial wire coming from the winch or reel. The aerial on leaving the fairlead swings backwards owing to the velocity of the plane, and takes for some distance a path roughly parallel to that of the bus, being thereby forced into good electrical contact with the metal tube of the fairlead. The aerial lead from the set is connected by a

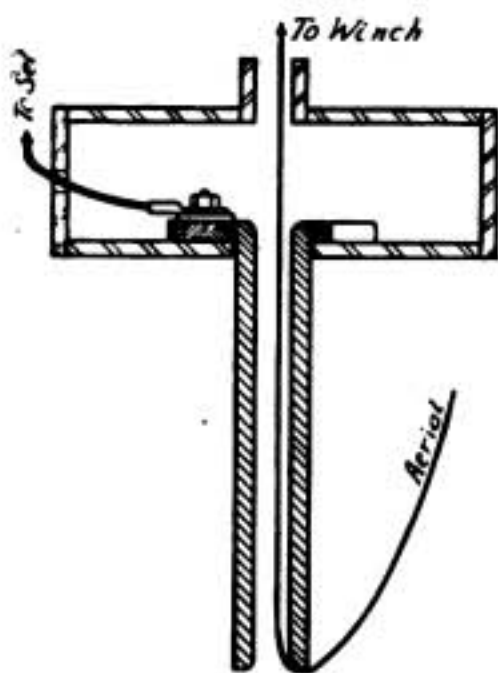

Fig. 15.

screw to a flanged part on the top of the tube, as shown, thus forming the equivalent of the "lead in" on a ground set. It is a good plan to protect the top of the fairlead by a wooden or rubber block or shield, so as to save it from damage by the feet of the pilot or operator.

#### EARTHING.

The earth lead from the set should be connected to as much of the metal work of the bus as possible. These parts constitute the capacity earth of the system, and the larger this can be made the more favourable will be the "form factor" of the aerial circuit. A good earth is obtained by running a couple of copper strips along the longerons and "bonding" all metallic parts. In addition to giving the maximum capacity, this arrangement considerably reduces resistance losses in the earth circuit, and increases radiation efficiency.

#### AERIAL WINCH OR REEL.

This is usually fitted on the left-hand side of the operator, at a suitable height for convenient manipulation. It is a simple matter to let the aerial down, but winding it in is somewhat more

fatiguing, particularly if the operator is forced into a cramped position whilst doing so. Consideration given to this point will save much heat and ill-temper in the air.

The reel is fitted with a spring band brake which in the normal position holds it against rotation. The fixed end of the aerial is secured to the drum of the reel by a short piece of cord or gut.

### DROPPING THE AERIAL.

In letting the aerial out it is sufficient to free the band brake by pushing in the spring-pressed spindle until it drops into a catch which holds the spring in compression and leaves the reel free to rotate.

The weight of the plummet then causes the aerial to unwind. It is advisable to brake the reel slightly with the hand in order to avoid too rapid a descent, as, if the plummet is allowed to drop quite freely, it will probably snap the cord by which the end of the aerial wire is fastened to the drum of the reel, in which case the role of the wireless gear will become purely ornamental so far as that particular trip is concerned.

### WINDING-IN.

Winding-in should be done as steadily as possible. The plummet will sway and jerk considerably as it comes in, particularly towards the end of the operation, and if it is subjected to extra strain by a too energetic operation of the reel handle will probably part company with the aerial, more especially if it is brought home with a nasty jar against the fairlead or guide. As it is of lead and weighs two or three pounds, the mishap is one which does not add anything to the popularity of the airman, particularly when it occurs over a crowded landscape.

A piece of thick rubber tubing fitted over the part where the plummet is spliced or fastened to the aerial serves to buffer the final shock as the plummet comes home, and is a safeguard well worth utilizing.

### RE-WINDING AFTER USE.

It is difficult in winding-in to ensure that the layers of wire are laid evenly and regularly on to the drum of the reel. Unless this is done, it is not safe to drop the aerial, as previously described, on the next flight, as in the rapid descent the wire would probably tangle and get jammed. It should therefore be a standing rule to have the aerial unwound after each trip and carefully and neatly re-wound on the ground ready for the next ascent.

### THE HANGING AERIAL.

Altogether the hanging aerial is a messy and inconvenient arrangement, but unfortunately there is, as yet, no practical alternative for transmitting purposes.

It is otherwise in the case of reception, where the use of the loop aerial is becoming general.

### SUMMARY.

In a general overhaul of the wireless installation of a bus, the following points are worth attention:—

See that the Fairlead is clean and not choked up with mud from the boots of the last operator. Also see that the bottom edge is not too grooved by the aerial wire to cause possible sticking or jamming in the notch.

Examine the band-brake spring on the winch, and see that the brake has sufficient grip and has not worn loose.

Look at the gut or cord fastening the aerial to the winch, and see that it is not frayed or liable to give should the

## AIRCRAFT WIRELESS SECTION.

aerial be "inadvertently" let out with a run.

See that the plummet is securely spliced or secured to the end of the aerial.

Take care that the aerial has been re-wound on the ground after the last flight, so that the coils lie neatly around the axle of the drum, ready to come off smoothly when the aerial is dropped in the air.

Take a general look at the wiring with particular attention to the earthing, safety plug, and key contacts (also signal lamp contacts, if used).

Test accumulators on load, and see that they are not placed in a position where the terminals may possibly be short-circuited by contact with metallic parts of the bus.

In tuning over the transmitters, see that all terminals and connections are O.K.; test the make and break—see that it is not "sticking." Try spark-gap adjustment. See that locking screws for gap and break are tight. Examine helix clips. See that closed circuit is correctly adjusted if working on given wavelength. Make sure that aerial is of proper length or is properly marked in accordance with previous calibrations of wavelengths for the bus in question, and that the operator knows what coupling to use with the given wavelength.

If after all this the wireless set goes wrong in the air, the first step should be to disintegrate it with a coal hammer, and the next to seek some other more interesting vocation in life.

*(To be continued.)*

---

## TESTS OF X-STOPPING DEVICES.

**A**PAPER by Major G. O. Squier, communicated to the Franklin Institute describes an investigation of various arrangements for improving reception through atmospheric interference. The chief conclusions arrived at from these tests may be summarised briefly as follows:—Tests carried out with frame aerials showed conclusively that they did not possess any advantage over the horizontal aerials, the ratio of signal strength to X-strength not being improved, while at times the signals on the frame aerials were prohibitively weak. Both audio and radio balancing between two frame aerials at right angles were tried, but without success. Simultaneous photographic records of X-impulses received on two loops at right angles to one another showed that the extrane-

ous disturbances did not occur simultaneously in two mutually perpendicular planes. A screened horizontal aerial was also tested, the screen consisted of loops of copper wire spaced at equal distances along the horizontal aerial, connected together by high resistance wires and earthed at several points. Repeated tests showed that this screening system possessed no advantages.

Enclosing the horizontal aerial in a covering of insulating material of low specific inductive capacity likewise showed no improvement. The signal strength obtained on an aerial composed of copper wire netting showed no improvement in the ratio of signal strength to X-strength, as compared with horizontal aerials while at the same time the signal strength on the wire netting aerial was very low.

# Aviation Notes.

## R.34 WIRELESS.

**T**HE responsible wireless personnel of the Royal Air Force is to be congratulated upon the excellent results obtained during the R.34's transatlantic trip. It is no exaggeration to say that all previous records of wireless work in the air have been surpassed. In addition most valuable experience has been gained which will bear fruit in good time for the betterment and advance of aero-radiology generally.

The airship carried two transmitters. One a C.W. valve set (Service type 15) for long-range work, and the other a Marconi Spark set. The former worked on a normal wavelength of 1,400 metres, the latter on 600 metres.

A telephony set, and a radiogoniometer installation for direction-finding in the air were also aboard.

The receiver, in particular the small Service type T.f., gave some remarkably efficient results.

Some of the distances covered both in receiving and transmitting are set out in the accompanying chart which gives a more illuminating illustration of the work done than could be set out in umpteen weary words.

It is a most encouraging record and is well worth a careful examination by those of our readers who are interested in the aviation field of wireless achievement.

The following is extracted from an official announcement by the Air Ministry on the work done during the outward voyage.

The Royal Air Force Station at Dundee exchanged signals at 1,000 miles. The R.34 sent messages that were read by the Air Ministry at 1,100

miles, by Wormwood Scrubbs at 1,135 miles and by Ballybunion at 1,600 miles. In one case, when the airship was approaching America, a signal was sent to her from the Air Ministry through the Marconi Station at Clifden, and a reply was received *via* St. John's, Glace Bay, Clifden and Marconi House, and thence to the Air Ministry all in twenty minutes!

The credit of being the first R.A.F. Wireless Station to "pick up" the R.34 on her return trip belongs to the Mullion Station, which received signals from R.34 a few minutes before this was accomplished by East Fortune and the Air Ministry Station.

This information was not available until too late to include it in the chart.

## AN APPRECIATION.

The following letter of thanks, addressed by the Air Ministry to the Management of the Marconi Wireless Telegraph Company, is published apropos of our remarks last month regarding the amount of wireless work involved in collecting the necessary meteorological data, and in otherwise contributing towards the success of the recent transatlantic flights:

"I am commanded by the Air Council to express their thanks for the valuable assistance your company rendered in connection with the recent transatlantic flights by H.M. Airship R.34. The generous and liberal use of your high-power stations, Clifden and Glace Bay, together with the work undertaken spontaneously by Cape Race Station, contributed largely to the success of these flights, and the Air Council greatly appreciates the wholehearted manner in which your company put its entire and elaborate organization

## AVIATION NOTES.

at the disposal of the Air Ministry.  
"The promptitude, too, with which all traffic undertaken by your Company, in this connection, was dealt with was most creditable."

I am, sir,  
Your obedient servant,  
(Sgd.) W. A. ROBINSON.

### STATICS EXTRAORDINARY.

Statics are generally the bugbear of the poor W/T. Operator only but apparently during the R.34's trip the whole personnel aboard became more intimately acquainted with the properties of electricity in bulk than they altogether relished.

Following the text-book method of accumulating charges by rubbing together non-conducting substances of different material, the airship in friction with the surrounding atmosphere collected quite a lot, sufficient, at all events, to raise her potential to a value that was more than good for her at times.

Theoretically this charge should not have proved troublesome except in the event of meeting a passing cloud loaded up with the opposite quality, in which case the ensuing discharge might, with the assistance of the cargo of 2 million cubic feet of hydrogen, have caused quite a considerable spark.

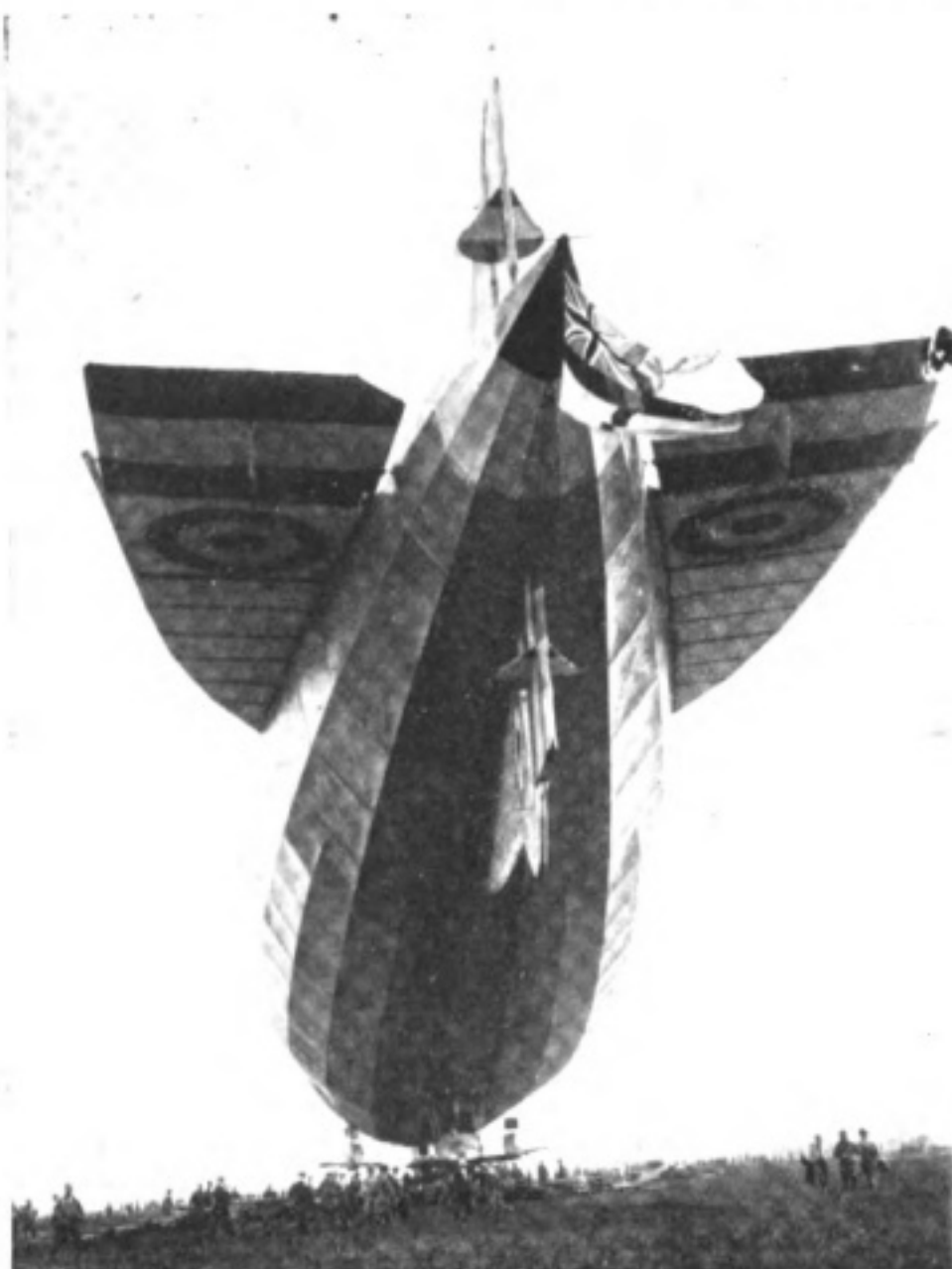

Photo by *The R.34 Landing in Roosevelt Field, Mineola.* Topical Press

Actually, however, whilst stopping short of causing a catastrophe, the superfluous freight appears to have fully maintained its characteristic "static" reputation by making itself a most thorough nuisance to all in the neighbourhood.

According to Faraday any such induced charge should have been purely superficial, and should have resided respectably on the exterior surface of the vessel, but according to the crew who ought to know, it did nothing of the kind. In fact several "other ratings" complained of being electrocuted with some severity, whilst the climax was reached when, as the record states, "one of the officers, on putting his hand into a bowl of water to wash, received a sharp shock." Everyone will agree that this was most unbecoming conduct, and it is understood that the whole matter is being investigated with a view to the necessary disciplinary action being taken.

This may or may not have the required effect, but at all events it will serve to warn our mutual enemy that he cannot with impunity disport himself on board H.M. Aerial Dreadnoughts in the same light-hearted spirit of malice that characterizes his dealings with ordinary common or garden wireless gear.

### THE GERMAN ZEPPELIN FLEET.

In a recent lecture to the London Topographical Society, Colonel de Watteville gave some interesting particulars as to the development and use of the Zeppelin during the war.

The earlier Army type was a conspicuous failure, no fewer than five being lost in the first few weeks. The Navy then practically took control of construction, and concentrated their efforts in perfecting the type that was subsequently used in the bombing raids against this country.

Altogether some 120 Zeppelins were built by the enemy during the war period, but out of that total there were never more than 12 or 16 ready to take the air at one time.

The lecturer stated that directional wireless sets were carried by all the Naval airships with satisfactory results so far as navigation was

concerned. On the other hand, it was the wireless gear that played traitor to the Hun, and proved a source of fatal weakness.

By a process of "diamond cut diamond" the same Zeppelin that was directed on its course by the help of wireless, was itself located and tracked by means of signals sent back



Photo by Sports and General  
Constructing a Wireless Telegraphy and Telephony Station at Roosevelt Field, Mineola, for the Reception of the R.34.



# SUPPLEMENT TO THE WIRELESS WORLD

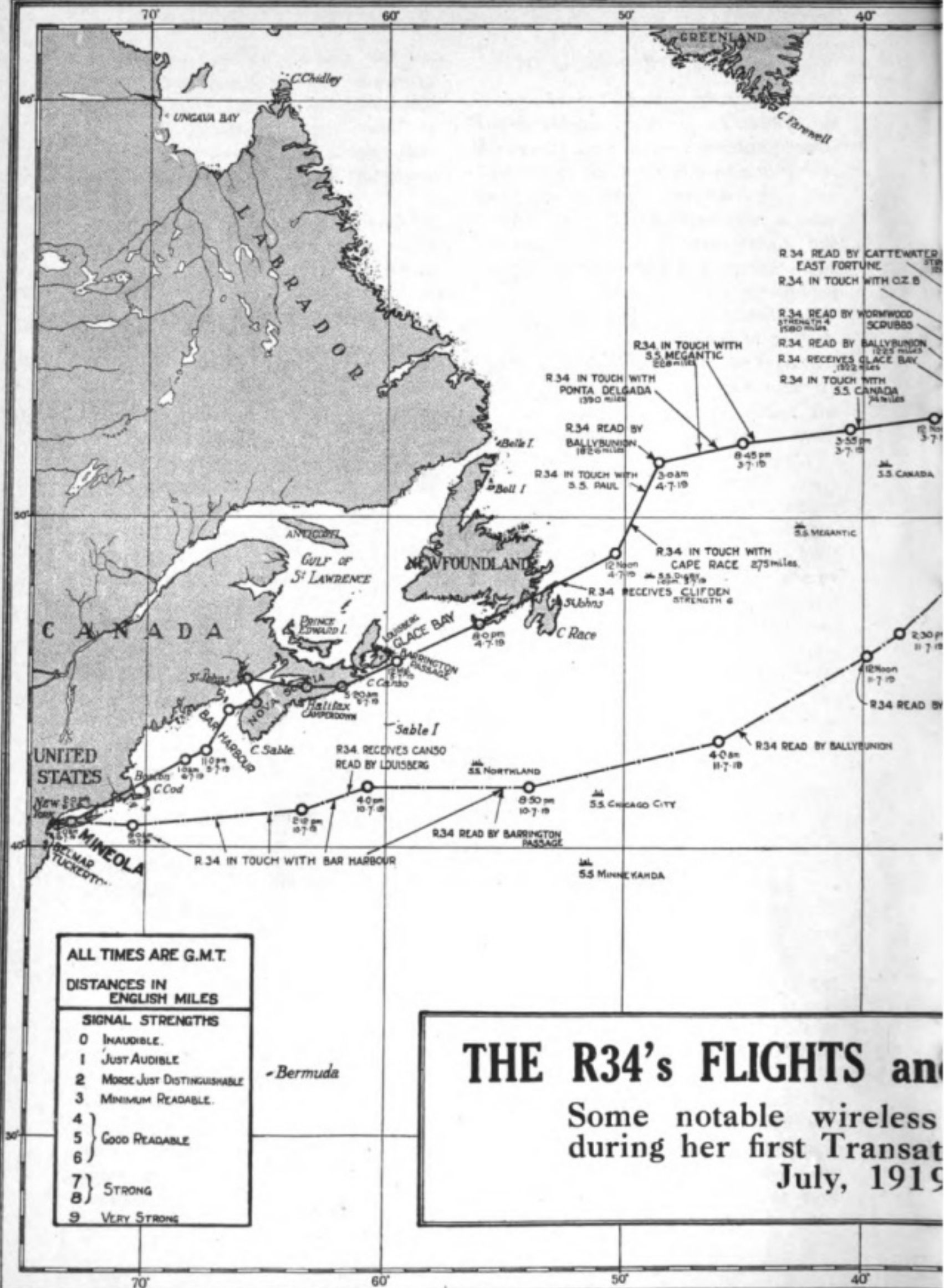



**RADIO WORK**  
 achievements  
 antipodal voyages,

## AVIATION NOTES.

to its base, but intercepted by our own directional stations.

With this information in hand, the time came when our preparations for their reception became so thorough that the Hun decided that the air-raid game was no longer worth the candle, and retired to think out an *ersatz* wireless that would only radiate in one direction.

### A FLOATING AERODROME.

The war has provided a number of "mystery" and "wonder" ships, but nothing to beat H.M.S. Argus.

She was only commissioned last September, and has had no opportunity of showing her worth, but she is the last word in floating aerodromes.

She carries between 25 and 30 aeroplanes as her complement. The "flying deck" is 240 feet long and 40 feet broad, and is 65 feet above the water-line.

The planes are housed in lower decks, and are hoisted up to the flying deck by elevators. During flying operations, the chart-house is sunk by means of hydraulic machinery below the level of the flying deck, leaving an absolutely clear and unimpeded space.

In order to provide an arresting device, the main elevator is lowered, leaving a large oblong hole across the flying deck. This is strung over with stout wires about the breadth of a landing-wheel apart. If the run of the plane after landing is excessive, the landing-wheels sink down between the wires as soon as she gets over the arrester. The under-carriage slides along on the wires, and the bus is brought to rest against the further lip of the elevator well.

This method only applies to the smaller craft. The heavier seaplanes alight near the mother ship and are hoisted aboard in the ordinary way.



Photo by Sports and General  
Chart outside Marconi House, Strand, showing the progress of  
the R-34 on her Atlantic Flights.

# The Library Table

## THE OSCILLATION VALVE

By R. D. BANGAY.

London: THE WIRELESS PRESS, Ltd.,  
pp. 215. Price 5s. net.

IN view of the enormous popularity enjoyed by Mr. Bangay's "*Elementary Principles of Wireless Telegraphy*," it is safe to say that radio workers and students will heartily welcome another book from his pen, for apart from the value of the information he conveys, Mr. Bangay without being a stylist writes with a force and a clarity peculiarly his own.

The discovery and development of the thermionic valve have revolutionised the practice of wireless communication to a far greater degree than the X-rays did that of surgery. As a detector and amplifier of electro-magnetic energy, the modern valve so well fulfils present requirements that the time has not yet arrived for us to look forward to the new invention which shall sweep it away, whilst as a transmitter it bids fair to displace to a very large extent the spark and the arc. There is still much to be said and done with respect to this instrument which in the space of five or six years has lifted wireless telegraphy to the high plane it now occupies, but the book under review is a notable step towards bringing wireless literature on a level with present theory and practice.

Here we have a volume of 210 pages illustrated with no less than 110 diagrams, and we are glad to note that, as is most fitting in a work of this nature, no space is wasted on half-tone blocks; too often these show little more than fine high light effects on the exteriors of instruments, whereas the

reader is mostly concerned with the *interiors* and the wiring diagrams.

The greater part of the book treats of the oscillation valve as applied to receivers, and although the subject well merits the amount of attention devoted to it, one wishes that the total space could have been more generously shared with the section on the valve as a transmitter. However, many a man who thinks he knows a great deal about valves is destined to find that this book will provide him with food for an amount of thought and study he little anticipates. The author has not contented himself with a mere paraphrase of a compilation of facts torn from other books or from miscellaneous papers, but has produced a book which gives really "inside information" because he has got really inside his subject.

The first forty-five pages are given over to general considerations of the telephone receiver, the rectification of high-frequency oscillations, the principles of "beat" reception for C.W., tuning and the effect of damping on the shape of the resonance curve. Next, the vacuum tube is discussed generally in the light of the electron theory, the section concluding with a very full treatment of the Fleming valve. Twenty-seven pages are allotted to the three-electrode valve as an introduction to an explanation of its application to receivers, these pages including, we are pleased to see, some useful information about the effect of the mechanical proportions of the valve, and the "Magnification constant" of valves.

Pages 110-132 comprise an account of the three-electrode valve as applied

## THE LIBRARY TABLE.

to receivers, and are followed by sections on the valve as a magnifier, high-frequency magnification, and the reaction principle. Next in order comes "The application of the three-electrode valve to the Transmitter" and the book concludes with an article on the theory of the soft valve.

The treatment throughout is non-mathematical, thus rendering the book doubly attractive to the elementary student and the non-specialising ama-

teur. The author possesses the happy knack of imparting knowledge easily; he neither refers his readers to a thousand and one other books nor takes refuge in a jargon which sends them to a scientific glossary and a mathematical expert. His book will win a great and deserved success because he has discerned and turned to account the supreme secret of teaching—the sacrifice of pedantry in the interests of the learner.

---

## TRANSATLANTIC RADIO RECEPTION

**A** COMMUNICATION to the Franklin Institute by Major-General G. O. Squier, Chief Signal Officer, U.S. Army, deals with the results obtained in the course of extensive research work carried out by the Radio Development Section of the U.S. Signal Corps during 1918. The fundamental object was the investigation of the reliability of various receiving stations for transatlantic wireless from the point of view of interference both from atmospheric and from other stations.

Six experimental receiving stations were equipped with apparatus for the comparison of signal strengths using the shunted-telephone "audibility-meter" method, in conjunction with a simple detecting valve circuit, that could be used either direct, or in combination with either one- or two-stage low-frequency amplification.

Low horizontal receiving aerials were used throughout. When using a single wire aerial of this type it was found that the received signal audibility was proportional to the length of the wire raised to the power of 1.2.

An examination of the extensive records obtained, indicated that the signals from a given station [Signals from Lyons, YN, were largely employed in these tests] may show a comparatively high audibility value at one or more of the stations on a certain date, and at the same time a low value at another station, and *vice versa*. It was also evident that the signals from a given transmitting station may have a high audibility value at a given receiving station on a certain date, while signals from some other station are comparatively weak at that particular time, and *vice versa*. It was also found that a given station might show a comparatively satisfactory signal audibility for a period of time of the order of a month or several months, while during some other period the signal audibility would be found to be low.

There was also some evidence that cloudiness over the Atlantic in the great circle between the two stations, resulted in low signal values at the receiving station. A period of high signal audibility in March (1918) was found to coincide with a period of abnormally high electrical conductivity of the air at the receiving end.

# Patent Section

122,640. Wireless signalling. Lowenstein, F., 397, Bridge Street, Brooklyn, New York, U.S.A. January 20th, 1919. No. 1392. Convention date, January 19th, 1918. Not yet accepted. Abridged as open to inspection under Section 91 of the Act (Class 40 (v)).

In multiple quenched spark-gap apparatus for producing high frequency oscillations by the condenser discharge system, the multiple gas is built up of a series of readily removable and replaceable units, each unit comprising one or more pairs of disc electrodes with annular

separates the two discs 20<sup>a</sup>, 21<sup>a</sup>. The pressure washer may be varied in shape or may be omitted. The stud passes through a large opening in the disc 21<sup>a</sup>, and the chamber in which the sparking takes place is air-tight. The cooling-fins are formed of rectangular sheets 31, preferably of copper, with circular openings to fit around the discs 20<sup>a</sup>, 21<sup>a</sup>, and with their vertical sides 33 flanged and overlapping, thus forming two or more narrow vertical tubes through which a draught of cooling-air will readily pass upwards. Sets of holes 311 in the cooling sheets 31 enable

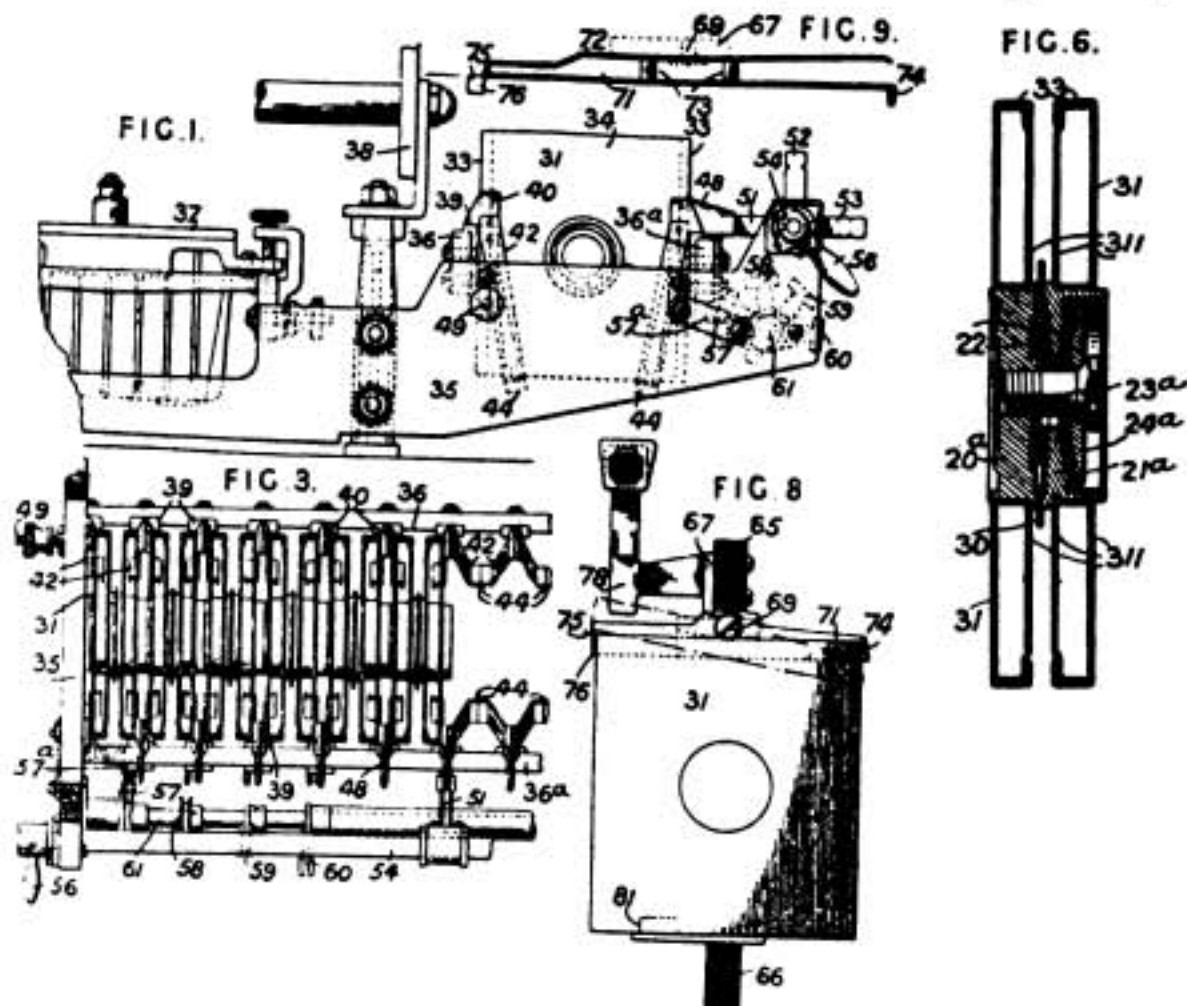

sparkling-surfaces and sheet-metal cooling-fans. Switch mechanism is provided for varying the number of gaps in circuit in relatively large, and in small, steps. Fig. 1 is a side elevation, and Fig. 3 a plan, of one arrangement, a separated unit being shown in Fig. 6. Silver sparking-rings 22 are secured to the adjacent surfaces of discs 20<sup>a</sup>, 21<sup>a</sup> of brass or other metal. The discs are flanged as shown and are secured to each other by a bronze stud 23<sup>a</sup>, which is screwed into one member and has a head bearing against a pressure washer 24<sup>a</sup>. An insulating-washer separates the pressure washer 24<sup>a</sup> from the disc 21, and an annular insulating-member 30

the sheets to be correctly aligned and also ensure that the insulator 30 is placed in the central position. The insulating-frame for supporting the sparking-units comprises a pair of end plates 35 connected by horizontal bars 36, 36<sup>a</sup>. Spaced along these bars are metal brackets 39 having pointed upper ends 40 and pairs of spring contact members 42 projecting downwards and in an inclined direction. When the gap units are removed, these contact members engage at their lower ends 44, and when a spark-gap unit is pushed downwards between the contacts, the cooling-fins 31 separate the spring members 42, thus putting the inserted unit in circuit. For varying the number of

## PATENT SECTION.

gaps in circuit in relatively large steps, a switching-arrangement is provided comprising a longitudinal shaft 54 operated between limit stops by a handle 56 and carrying three contact-arms 51, 52, 53 separated angularly and axially and arranged to make contact with projections 48 on the brackets 39. One terminal of the sparking-set is connected electrically to the shaft 54 so that all gaps to the right of the operative contact-arm 51, 52 or 53 are short-circuited. The arms are adjustable along the rod 54 and are locked by suitable detents. An auxiliary short-circuiting device giving a finer adjustment comprises a shaft 61 with angularly-displaced contact-arms 57, 60 placed opposite the successive units at the left-hand end of the set. The shaft 61 is in electric connection with the terminal 49, and by placing any of the switch arms 57 in contact with the corresponding member 57<sup>a</sup>, the gaps to the left are short-circuited. The contact members 57, 60 have wide engaging faces in order that one may

engage before the next one has disengaged. The frame supporting the gap units also carried a condenser 37 and a support 38 for the transmitter inductance coils. In a modified arrangement spring clamps bearing frictionally on the shafts 61, 54 are connected respectively to the condenser 37 and to a switch arm of a variable inductance. A modified form of holder for the gap units is shown in Figs. 8 and 9. Longitudinal bars 65, 66 of insulating material carry spring contact members 71 and distance-blocks 81 respectively. The spring members are centrally pivoted at 69 to brackets 67 and comprise two parallel arms 71, 72 connected by cross-pieces 73. The arm 71 has a stop 74 at its rear end and a stop 76 and lip 75 at its front end. When it is desired to remove a gap unit 31, the lip 75 is raised and the rear stop 74 pushes the unit forwards. At the same time, the arm 71 makes contact with a projection 78 on the bracket 67 corresponding to the adjacent unit, so that the circuit is maintained.

---

## PERSONAL NOTES

### NEW FELLOW OF THE I.R.E.

**M**AJOR RUPERT STANLEY, R.E., well known as a radio expert and the author of a book on wireless telegraphy, has been elected a Fellow of the Institute of Radio Engineers. Major Stanley is Professor of Electrical Engineering at the Belfast Technical Institute, but since 1915 has been engaged in wireless work, both experimental and instructional, with the British Army in France. He is a Chevalier of the Legion of Honour.

• • •

### MENTIONED IN DESPATCHES.

The names of the following wireless officers and N.C.O.'s. appeared in the "London Gazette" of June 3rd, 1919, "mentioned in despatches" for "valuable services rendered":—

Lieut. J. W. Bailey, M.C., R.E.,  
T./Lieut. J. A. Cooper, R.E.,  
T./Lieut. A. H. E. Rogers, R.E.,  
73402, Sgt. P. Greig,

244326, Cpl. (A./Sgt.) H. W. Shuker,  
152319, L./C. (A./Cpl.) F. Whyte.

• • •

### MARCONI MAN WINS D.F.C.

Lieut. C. A. Moth, now demobilised and on the staff of Marconi's Wireless Telegraph Co., Ltd., has recently been decorated by H.M. the King with the Distinguished Flying Cross for his intrepid work as a night-bomber in France. He has taken part in forty-two night raids over the German lines and towns, and although wounded in October, 1918, won his decoration in November, 1918, for a fine flying and bombing feat.

• • •

### AN EX-AMATEUR ON THE R.34.

Lieut. R. F. Durrant, the wireless officer of the R.34 during her recent great flights to America and back, was originally an amateur wireless worker and a member of the North Middlesex Wireless Club.

# The Construction of Amateur Wireless Apparatus

*This series of Articles, the first of which was published in our April number, is designed to give practical instruction in the manufacture of amateur installations and apparatus. In the following article the author deals with the important question of CRYSTAL AND VALVE RECEIVING CIRCUITS. The Wireless Press, Ltd., has arranged with Marconi's Wireless Telegraph Co., to supply complete apparatus to the designs here given, as soon as Amateur restrictions are released.*

*Article Six.—CRYSTAL AND VALVE RECEIVING CIRCUITS.*

**W**E propose in this article to give the amateur a résumé of the various types of crystal and valve receiving circuits in general use. It will not be possible to give details of all the arrangements it is possible to employ, but if the reader has obtained a sound working knowledge of the subject he will have no difficulty in adapting any of the examples given to his own particular requirements. The functions of a receiving circuit are (a) to gather energy from the ether wave and store it in suitable oscillatory circuits, (b) to convert this stored electrical energy into sound waves in order that it may be detected by the ear. The three-electrode valve may be used as an amplifier. In the second case it may be used to amplify the current which is flowing in the telephone circuit of the receiver, and as this current is of note frequency a valve used in this manner

is known as a note magnifier. A third use for the valve occurs in the reception of continuous waves, in which case local oscillations produced by the valve are used to give beat tones with the incoming signal in order to render it audible in the telephone receivers.

We would draw the amateur's attention to the fact that in all the receiving circuits illustrated we have indicated a telephone transformer to be used in conjunction with low resistance telephones in preference to the employment of high resistance telephones direct. We would urge the amateur to make a practice of always using this arrangement as insulation troubles in valve circuits are thereby avoided. Imagine that we are employing high resistance telephones in the sheath circuit of a valve requiring a hundred volts or more on the anode. Since the negative terminal of the plate battery will be connected to the filament circuit, if the telephones happen to be on the positive side of the battery, there will be the full 100 volts between the metal parts of the telephone and the windings owing to leaks between the filament battery and the table, etc. This high voltage is very likely to break down the delicate insulation of the telephone



## CONSTRUCTION OF AMATEUR WIRELESS APPARATUS.

windings, thereby rendering them useless. The trouble is avoided by using a telephone transformer. It is quite easy to make the insulation between the windings of the transformer of a high order, and since any voltage which may arise from the above-mentioned cause will be between these windings breakdowns are avoided. The combination of telephone transformer and low resistance telephones is quite as sensitive as high resistance telephones, and therefore the amateur is recommended to use the arrangement even in simple crystal circuits.

In Figs. 1, 2, 3 and 4 we have indicated four representative types of receiving circuit. For the sake of clearness in each case a simple crystal detector is shown. Fig. 1 is a single circuit receiver consisting of an aerial tuned to the desired wavelength by means of a variable inductance; the rectifier circuit, composed of a crystal, a potentiometer and a telephone transformer, being connected directly across the inductance from aerial to earth. This is about the simplest type of receiver it is possible to devise. Its efficiency is low, but it is quite suitable for receiving time signals, press, etc., from high-power stations.

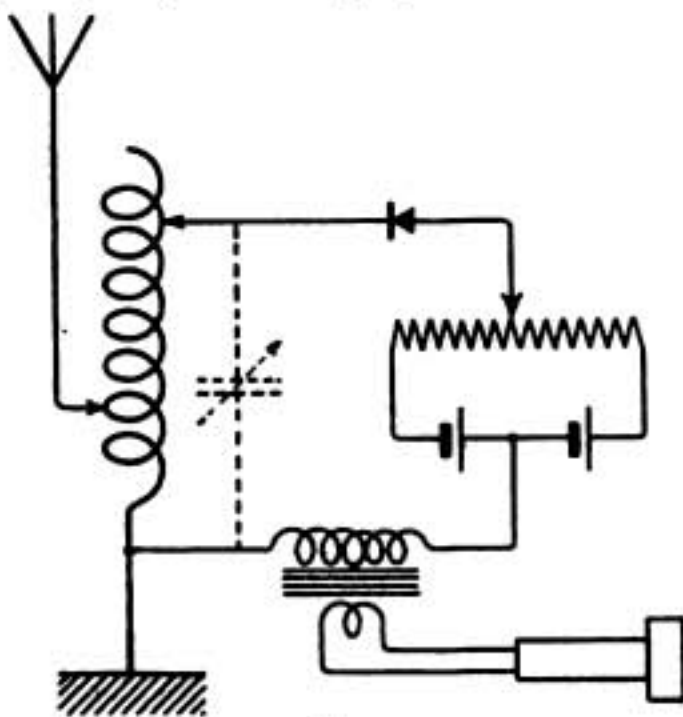

Fig. 1.

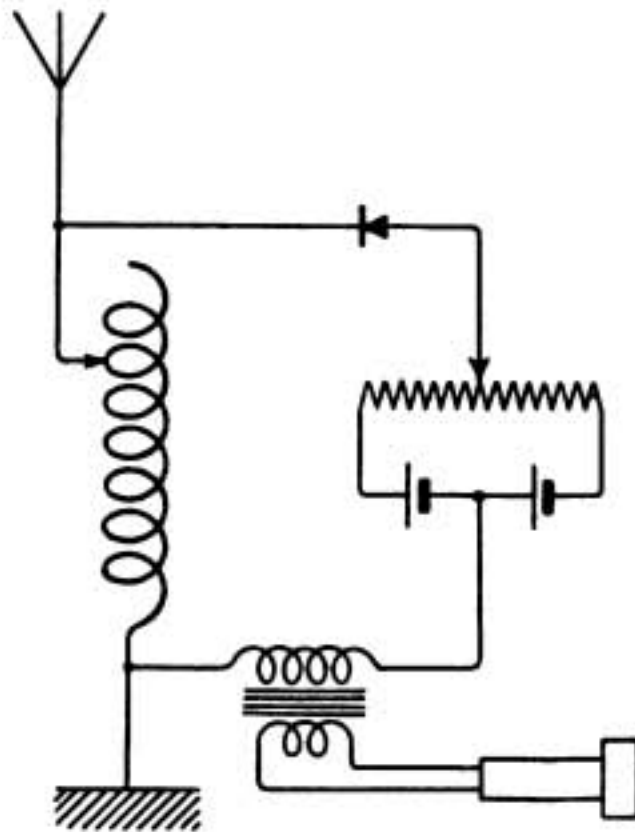

Fig. 2.

Fig. 2 illustrates the well-known "double slider" circuit; in this case the crystal circuit, instead of being connected directly across the aerial-earth terminals of the tuning inductance, is connected to a second tapping on the inductance which is adjustable. On sliding this second tapping to and fro a best point can be found on the inductance at which position the loudest signals are obtained. The arrangement is really an auto-jigger, the self capacity of the coil acting as the secondary tuning condenser. For very long waves it is sometimes necessary to connect a small variable condenser from the second slider to earth as indicated by the dotted lines. This circuit is considerably more efficient than that shown in Fig. 1, but it leaves much to be desired from the point of view of jamming. A great deal depends upon practice in manipulating the sliders to obtain the best effects. In Fig. 3 is shown one of the best and most efficient receivers that can be devised. It consists of an aerial tuned by means of a variable condenser and a variable inductance to the wavelength

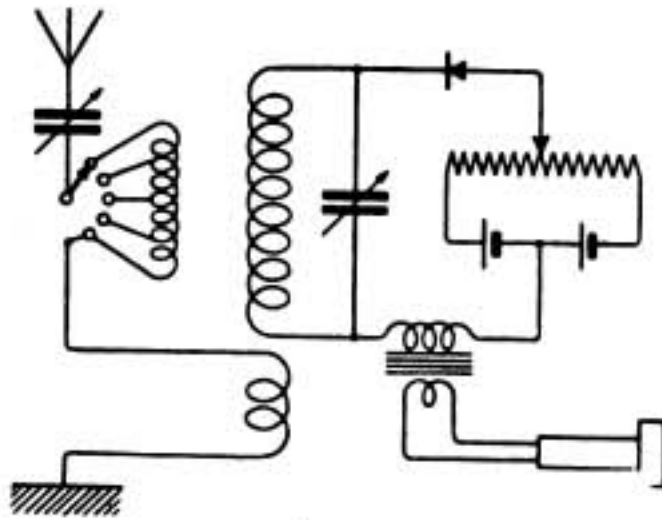

Fig. 3.

to be received. A coupling coil is also provided in the aerial circuit by means of which it can be magnetically coupled with the jigger secondary, composed of a long inductance tuned to the same wave as that of the aerial by means of a small variable condenser. The crystal circuit is connected directly across the terminals of this latter condenser. In this case we have two separate and distinct oscillatory circuits, each of which can be designed to perform its particular functions in the most efficient manner. In order to secure the greatest possible freedom from jamming the arrangement shown in Figure 4 is sometimes employed. This is simply the two-circuit receiver which we have just explained with the difference that instead of the energy being transferred directly from the aerial to the detector circuit it is handed on via the intermediate circuit A, this latter consisting of two inductances connected in parallel across a variable tuning condenser. By very accurate tuning of all three circuits, and by working with the weakest possible couplings the greatest freedom from jamming can be secured. It is worth while noting that in order to obtain a large range of wavelength with a given pair of inductances and a single variable condenser, short waves can be obtained by the parallel connection shown at A, whilst the series connection B will give

a second range of longer waves. If the two inductances are equal, any particular reading on the variable condenser will represent just double the wavelength when the B connection is employed as that obtained on the A connection. Generally the amateur will be quite satisfied with the results of the circuit shown in Fig. 3, and we recommend this for all ordinary requirements.

In regard to the type of crystal to be employed we strongly recommend the reader not to waste time trying out all the various combinations of minerals which have been used as detectors. The only really practical crystal to employ is carborundum. It may not be quite as sensitive as some combinations when a lucky adjustment is secured, but its steadiness and reliability far outweigh any such advantage which may be possessed by any of the other types. It is necessary to use a potentiometer in connection with the carborundum crystal, but a good carborundum crystal, used on properly designed circuits with a correct adjustment of the potentiometer, is the most reliable and satisfactory detector in existence.

The design of the circuits is most important to secure the best results. The aerial tuning condenser should not be of too small a capacity, say, not less than .002 microfarads. Of course, a variometer of one of the types described in the last article may be used to give the necessary continuous variation of tuning between the tappings on the aerial tuning inductance, provided that the wave to be received is not shorter than the natural wavelength of the aerial. A series condenser is essential if it is desired to receive waves shorter than the natural wavelength of the aerial. Do not wind the inductances for the aerial circuit with a wire of very fine gauge. No. 20 or 22 S.W.G. is about the smallest that can be used without loss of efficiency. Always use

## CONSTRUCTION OF AMATEUR WIRELESS APPARATUS.

double silk-covered wire, single silk is liable to have deficient insulation in places, and a short-circuited turn may result in a close wound coil. We have already pointed out that the coils should be wound in only one layer for the best results.

The secondary circuit, across which the crystal or valve is connected should be designed to have the maximum possible ratio of inductance to capacity. That is, the inductance should be large and the tuning capacity small. The amateur will do well to make it a hard and fast rule that his secondary tuning condenser shall under no circumstances exceed .0003 microfarads in capacity. This applies to receivers employing a carborundum crystal as detector, or a three-electrode valve as a high frequency amplifier or detector. It is not so important to keep this condenser small in the case of a heterodyne continuous wave

receiver, or when using certain low resistance mineral combinations as the detector. Quite fine wire may be used for the secondary inductance, No. 28 double silk-covered is suitable, and the coil should be wound evenly with the turns close to each other. It is important to notice that the circuit should be connected up exactly as shown in the diagrams. One end of the secondary circuit must go straight to the crystal or valve in order that the maximum possible potential may be applied to the detector. This point is essential to the satisfactory working of the receiver, as if any extra capacities are introduced at the high potential end of the jigger signals will suffer in strength. The insulation of the jigger secondary from the table or support should be kept as good as possible, if an experimental circuit is being made up with the coils lying loose on the table, it is desirable to insulate the jigger secondary by placing pieces of

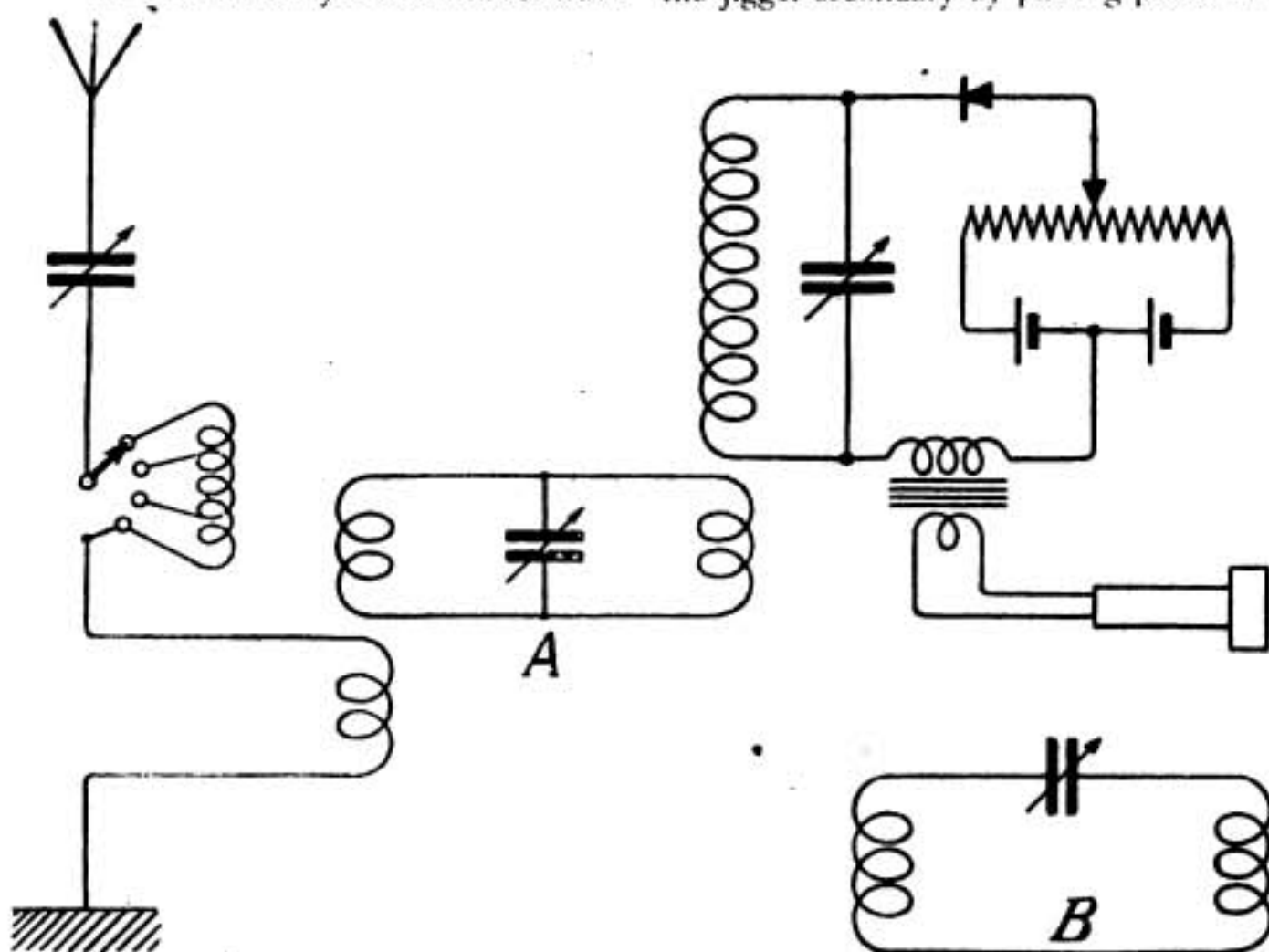

Fig. 4.

ebonite underneath it. The separate halves of porcelain cleats form very convenient insulators for supporting any apparatus when experimenting.

The intermediate circuit (A fig. 3) should have a fairly small ratio of inductance to capacity. The condenser may be of .01 microfarads or more capacity. If the amateur does not possess a variable condenser of this large capacity, the same result can be obtained by placing a number of fixed condensers in parallel with a small variable condenser. If the fixed condensers are arranged on a switch so that any number can be connected at a time a continuous variation of capacity up to any desired value can be obtained. It is preferable to make the two inductances in the circuit equal in value, and the reader should remember that the effective inductance in the circuit is half the inductance of one coil when the parallel connection shown at A is employed. Consequently when calculating out the circuit each coil must have an inductance double the value required to tune to the receiving wavelength with the condenser in use. If possible stranded wire should be used for these inductances for the best results, but quite good effects can be obtained from intermediate circuits wound with No. 22 double silk-covered copper wire. When using an intermediate circuit, care should be taken that there is no direct electrostatic or magnetic coupling between the aerial and the jigger secondary circuit. The aerial coupling coil and tuning inductance should be some distance away from the jigger secondary. A good test to settle this point is to remove the intermediate circuit altogether, when it should not be possible to hear the strongest signals or atmospherics in the phones. If any signals come through it is an indication of direct coupling and the coils should be rearranged until silence is obtained.

If the intermediate circuit is a good one, the tuning on the intermediate condenser should be sharp, and it should be possible to work with very loose couplings between the various circuits.

It is sometimes a little difficult to find a station on an intermediate circuit receiver owing to the number of adjustments involved. The best method of procedure is to take away the intermediate circuit altogether as a start, coupling the aerial directly to the secondary circuit by means of the aerial coupling coil. The aerial and secondary can then be tuned up to the incoming signals by adjustment of the aerial tuning inductance and the condensers. When the best signals are obtained separate out the aerial coupling coil and the secondary circuit until no signals can be heard, making no change in the tuning. The intermediate circuit can then be introduced as shown in the diagram, and tuned up to the signals by means of its variable condenser. Then by careful adjustments of all couplings and tuning condensers the complete circuit can be brought into exact resonance with the wave being received. Keep all couplings as loose as possible to get the best effect in the matter of cutting out jamming.

In our next article we hope to give the amateur some simple types of valve receiving circuits. It will be understood that the general remarks we have made above, although given in particular for crystal receivers, apply also to the circuits used in conjunction with the three-electrode valve. Although it is not as necessary to reduce all resistances in the oscillatory circuits associated with the valve, it is nevertheless desirable to do so. The notes concerning the ratio of inductance to capacity of the jigger secondary apply with equal force to the valve circuits, and the amateur will obtain the best results by building his circuits in correct proportions.

# Questions and Answers

**NOTE.**—This section of the magazine is placed at the disposal of all readers who wish to receive advice and information on matters pertaining to both the technical and non-technical sides of wireless telegraphy. Readers should comply with the following rules: (1) Questions should be numbered and written on one side of the paper only, and should not exceed four in number. (2) Queries should be clear and concise. (3) Before sending in their questions readers are advised to search recent numbers to see whether the same queries have not been dealt with before. (4) The Editor cannot undertake to reply to queries by post. (5) All queries must be accompanied by the full name and address of the sender, which is for reference, not for publication. Queries will be answered under the initials and town of the correspondent, or if so desired, under a "nom-de-plume." (6) Will readers please note that as amateurs they may not at present buy, construct or use apparatus for wireless telegraphy or telephony. (7) Readers desirous of knowing the conditions of service, etc., for wireless operators, will save time by writing direct to the various firms employing operators.

C.E.S. (Sussex).—Asks: (1) How much closer can the jigger primary and secondary of a 1½ K.W. set be coupled when using a rotary discharger than when using a fixed discharger?

**Answer.**—It is impossible to give any definite figures for this coupling without measurement on the actual set, as the length of aerial and the amount of A.T.I. for any given wavelength varies with each station.

There would not in any case be much difference between the two couplings, as with a well-adjusted fixed discharger the oscillations are fairly well damped.

**Question (2).**—What would be the approximate transmitting range obtained with this closer coupling?

Since the tighter coupling obtained as explained in (1) is small, there would be little increase in the transmitting range.

**Question (3).**—Does the insertion or removal of the whole of the A.T.I. affect the coupling between the open and closed oscillating circuits?

**Answer.**—Yes, the insertion of the whole of the A.T.I. will decrease the coupling. The coupling of any two circuits is determined by

$$k = \frac{M}{\sqrt{L_1 L_2}}$$

where  $k$  = coupling

$M$  = Mutual inductance of primary and secondary coils, and

$L_1$  and  $L_2$  = Self-inductance of primary and secondary coils respectively.

Hence it will be seen that if either  $L_1$  or  $L_2$  are increased or decreased,  $k$  will be either decreased or increased.

On a ½-K.W. ship set if the coupling is set at 6 with no A.T.I. and a single wave is obtained, the coupling may have to be increased to 10 when all the A.T.I. is used.

**Question (4).**—The unsteadiness of the asynchronous disc discharger is due to successive spark discharges not being timed uniformly. In an asynchronous discharger the successive discharges of the condenser are not of constant amplitude, and therefore successive spark dischargers are not of equal power. By very careful adjustment of the speed of the disc the gap can be made to discharge the condenser at points of equal amplitude which results in a more uniform note and a steadier disc position. It is, however, doubtful if any asynchronous disc can be made to run as steadily as a synchronous disc.

R.J.T.M. (Surrey).—Wishes to know if with a secondary winding of a receiver sliding into the A.T.I. the bottom of the A.T.I. should be connected to one end of the secondary coil.

**Answer.**—No. The bottom of the A.T.I. winding should be directly connected to earth, and not to the secondary inductance.

With this exception the connections are the same as the diagram sent with the question.

See that the secondary tuning condenser be not more than 0.00025 mfd. capacity.

G.E.H. (North Wales).—Before proceeding to answer our correspondent's many questions on Magnifying valves we should like to point out that owing to the limited amount of space at our disposal we are compelled to limit the number of questions from each correspondent to not more than four. However, as the following questions are of general interest, bearing as they do on a subject comparatively new to the bulk of our readers, we think it would be in their interests to make an exception in this case.

All the questions relate to the action of the Round valve when used on a Franklin circuit, a diagram of the connections being reproduced.

**Question (1).**—Why is it that placing the A.T.C. between the aerial and the A.T.I. gives stronger signals than when the A.T.C. is placed between the A.T.I. and earth?

The reason for the decrease in the strength of signals when the A.T.C. is connected between the A.T.I. and the earth is because in this position the condenser is shunted by the battery leakage to earth, which is equivalent to connecting a high resistance across the condenser. When the A.T.C. is placed between

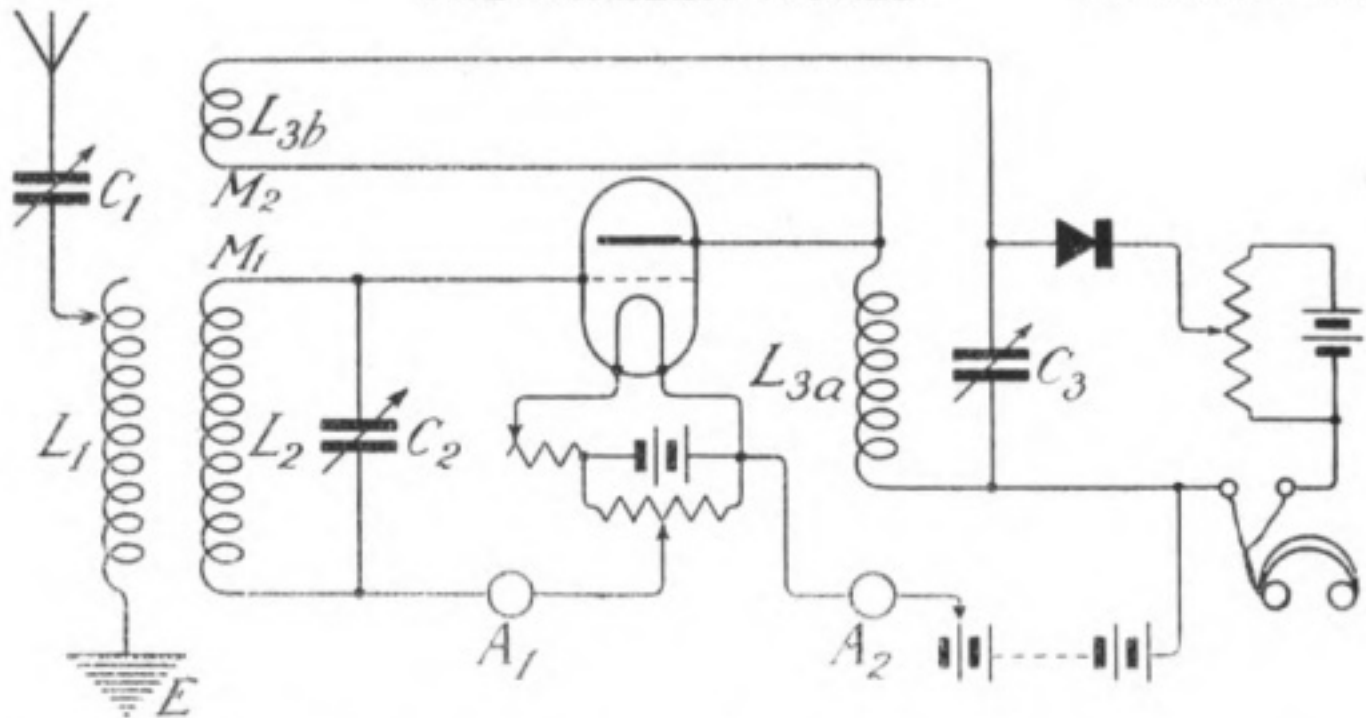

the aerial and the A.T.I. the condenser is unshunted by any external path, and, therefore, none of the strength of the received oscillations is lost.

*Question (2).*—Is the coupling between  $L_{3b}$  and  $L_2$  negative or positive?

That is, when  $L_2$  is impulsed by a momentary current so that the North pole of a magnet is towards the letters  $M_2$ , is the resulting impulse through  $L_{3b}$  in such a direction that the North pole of coil  $L_{3b}$  also points towards  $M_2$ ?

*Answer.*—It is impossible to say what is the polarity of the coil  $L_{3b}$  with respect to the coil  $L_2$ . The coil  $L_2$  is only impulsed by coil  $L_{3b}$  when the currents in the plate and grid circuits are in phase, that is when they are in tune, and this phase relation will depend on the adjustment of the plate condenser  $C_3$ .

*Question (3).*—As the strength of a signal depends on the total charge in  $C_3$  for rectification by the crystal, how can the greatly increased strength of signals be accounted for when the valve is softened until the grid current shows backlash?

*Answer.*—This is due to the plate current curve being steeper for a soft valve than a hard one, hence a small variation in the voltage of the grid will produce a greater variation in the plate current.

*Question (4).*—Is the howl noticed in tightening  $M_2$  a rectified beat note? If so, why cannot it be obtained when the valve is hard?

*Answer.*—Yes, the howl is a rectified beat note, but this cannot be obtained with a hard valve, as the valve is not working at its magnification point.

*Question (5).*—Why should there be an improvement in the strength of signals when receiving short wavelengths on a low resistance circuit?

*Answer.*—The strength of signals depends on the amplitude of the incoming wave, and if

the circuit possesses high resistance then the oscillations are damped out quicker than they would be in a circuit of low resistance. When reaction is used the amplitude of the incoming waves is increased, but the amplitude is not increased to such an extent in a high resistance circuit as in a low resistance circuit.

Our correspondent proceeds to state that it is much easier to "soften" a valve when the crystal is on a good working point, and that if the valve is softened the crystal potentiometer slider must be moved, thus using a different point on the rectifying curve of the crystal.

We have not found in any receiver using Franklin's circuit that the valve is easier to soften when the crystal is on a good working point, neither have we noticed that when the valve is softened the crystal potentiometer requires readjustment. We can only suggest that before softening the valve the circuits were not in the best adjustment.

The crystal has no effect whatever on the valve's internal condition.

*Question (7).*—Why is it possible to use a softer valve for radio frequency amplification than for "note" amplification?

*Answer.*—Because if a soft valve is used for "note" magnification it is much more difficult to prevent "singing" in the telephones than if a hard valve is used.

W.V.M.P. (Ealing).—States, in view of our recent remark that "the exact action of a rectifying crystal is not yet understood," that he has always held the opinion that the action was due to the polarization of the incoming waves, and asks if this is a possible explanation?

*Answer.*—The polarization of the incoming waves cannot account for the rectification action of a crystal detector. When these waves excite a receiving aerial, oscillatory currents are set up in the aerial circuit and it is these oscillatory high frequency currents

## QUESTIONS AND ANSWERS.

which are rectified into continuous current impulses by the action of the crystal.

Has W.V.M.P. in mind the electrolytic polarization of the crystal itself? According to G. W. Pierce in his "Principles of Wireless Telegraphy," the action of electrolytic polarization of the crystal together with the production of a thermo-electro-motive force, due to this polarization, plays an unimportant part in the rectifying properties of a crystal.

A.B. (Newcastle-on-Tyne).—Wishes to know if it would be possible to send a parallel beam of wireless rays from a parallel reflector to fall on a tube of filings about half a mile away. He wishes the rays to fall directly upon the coherer thus dispensing with a reflector at the receiving end. Also would such a coherer act if the rays fall in only one part of the coherer.

Answer.—Our correspondent evidently wishes to revert to the early days of Wireless Telegraphy when Marconi first used reflectors, but subsequently gave them up on account of their becoming too large for commercial work.

Before we say anything about the transmitting end let us see about the receiving end. Our friend evidently does not know that before any detector can indicate the presence of electromagnetic waves it must be included in a circuit round which induced currents can flow. Hence some auxiliary apparatus must be used in conjunction with the detector. A receiver in its simplest form consists of an aerial and the detector. Now before any induced currents caused by an electromagnetic wave can flow in a receiver, the receiving circuit must be tuned to the wavelength of the transmitting circuit. In our simple receiver of an aerial and detector this can be accomplished by varying the length of the aerial, thereby altering the inductance and capacity of the circuit. A.B. makes no mention of any receiving apparatus except the coherer and from his question it seems that he expects the "wireless ray" to excite oscillations in the detector alone. Hertz and Marconi in their original experiments used a "resonator" at the receiving end, the frequency of the resonator being so adjusted that the circuit would oscillate to the wavelength of the transmitted waves.

As regards the transmitting apparatus, we think that A.B. will experience considerable difficulty in obtaining a "parallel wireless ray" half a mile long.

Electromagnetic waves can be reflected by the use of metallic sheets.

SERGEANT INSTRUCTOR (Wigan).—Asks (1) If a Fleming valve can be made out of a 4V., 5 amp. metal filament ash lamp?

Answer.—We see no reason why a Fleming valve should not be made out of a flash lamp, but it would have to be done by a very skilled glass-worker.

Question (2).—Is it better to have a high or low vacuum valve? It is impossible to give a definite answer to this question as it depends on the purpose for which, and the circuit in which, the valve is to be used.

Question (3).—Is a Topler mercury pump suitable for exhausting the bulb?

For exhausting the bulb of a Fleming valve or any other valve which does not require a vacuum of a higher order than about .000012 mm. a Topler pump is suitable. For valves requiring a vacuum of a higher order, as is the tendency in modern valve practice, a Topler pump is not suitable and liquid air is often used.

(4) We regret we cannot spare the space to describe how a valve is used in a transmitter, but our correspondent can find full information on this subject in any recent book on Wireless Telegraphy.

C.H.G. (Matlock).—(1) The connection for a single circuit receiver using a valve to magnify the received signals, and rectifying by means of a crystal, are given in answer to Capt. de la R. in the May issue of the WIRELESS WORLD. Diagram 4 is the same as Diagram 3 except for the addition of a reactance coil in the sheath circuit.

The inductance and condenser are included in the sheath circuit in order to do away with the necessity of producing a rectified current in the sheath circuit. Under these conditions the grid potential can be adjusted so that the received oscillations will produce the greatest change in the sheath current. The sheath oscillatory circuit is tuned to the incoming signals and the current flowing in this circuit is rectified by the crystal.

It is not essential to have a variable condenser in the sheath circuit, but it is far preferable.

Question 2.—The easiest way to make a reactance coil is to wind some wire about No. 34 S.W.G., D.S.C., on an ebonite former. Let the former be of smaller diameter than the A.T.I. Connect the lower end of the reaction coil to the plate of the valve, and insert reaction coil in the earth end of the A.T.I. It will soon be found by experimenting whether there are enough turns on the reaction coil.

It is necessary to be able to tune the sheath circuit if a crystal is used as a rectifier, but it is not necessary to have two inductance coils. The reaction coil with a condenser across it suffices for the sheath oscillatory circuit. This condenser must be of small capacity, not more than about .00025 mfd.

Question 3.—Case A: 600 metres. Probably EGE, the military station at Barcelona.

Case B: 2,200 metres. Probably Nantes.

Cases C, D, E and F: Cannot identify. Why not listen for their call signals, which are much more reliable evidence.

"DORRAN" (Aberdeen).—Asks: (1) The use of the sheathed coil connecting the D.F. to the type 55 Receiver, and the tin foil connected to the casing of the receiver?

Answer.—The use of these sheathed coils enables the D.F. Apparatus to be used with greater accuracy than would be the case without them. We regret, however, we cannot go into the full details of why this is so owing

to questions of space, but the matter will, in all probability, be dealt with in a future number of the WIRELESS WORLD.

(2) Requires details of the R.A.F. generator with two commutators used for wireless telegraphy.

This machine is a self-exciting D.C. Generator. The armature is wound with two separate windings, one, the low tension winding, the other the high tension winding. The L.T. winding is connected to a commutator and supplies current to a field magnet winding and also to any external circuit for the purpose of charging cells or lighting the filament of a valve.

We regret we are not at liberty to give our correspondent the connections at present, and suggest that he keep his eye on the WIRELESS WORLD, where further information may, in due course, be published.

A.O.G. (Dover).—(1) The majority of D.F. Stations at present in commission are controlled by the Admiralty, to whom application should be made.

(2) The system mostly in use at present is the Bellini-Tosi.

QUERY (Gt. Yarmouth).—Asks: (1) If placing the tuning lamp in series with the aerial, instead of in parallel, would render the aerial circuit non-oscillatory?

Placing the tuning lamp in series with the aerial would not render the circuit non-oscillatory, but owing to the increased resistance of the aerial circuit, the oscillations would be more damped and, therefore, would be weaker in strength.

We quite fail to appreciate Query's remark that "the lamp would be burned out." If he tried transmitting with this arrangement most certainly it would, but we hope our friend is not under the impression that it would be burned out by any received wave, no matter what the signal strength be.

(2) How is it that moving the D.C. brushes of a 1½ K.W. rotary converter into the neutral position causes an increase in armature speed, with a consequent rise in A.C. volts?

Answer.—In the first place owing to the magnetisation of the armature, the magnetic field due to the field magnets is distorted. This distortion causes the neutral position to be behind the midway between poles position, and it is in this position that the brushes must be set in order that there shall be minimum sparking. Now moving the brushes against the direction of rotation of the armature will increase the speed of the armature while moving the brushes in the direction of rotation will decrease the speed of the armature. This increase or decrease in speed is due to the resultant magnetic field being either weaker or stronger than when the brushes are in the neutral position.

Now in a converter with a common winding the maximum voltage of the A.C. side is equal to the voltage supplied to the D.C. side,

so that the R.M.S. value of the A.C. voltage is equal to  $\frac{\text{D.C. volts}}{\sqrt{2}}$ .

Obviously then an increase in armature speed in a weakened magnetic field cannot give rise to an increase in A.C. volts, and we suggest that Query repeats the experiment, taking greater care with his readings.

\* \* \*

Mr. F. G. Butler, 37 Harroway Road, York Road, Battersea, wishes to get into touch with some one residing in S.W. London, who will give him buzzer practice. He is willing to pay, but is not prepared to pay at the rate usually asked by training colleges.

#### SHARE MARKET REPORT.

Business has been fairly active in the shares of the Marconi group during the past month. The ordinary shares have been subjected to sharp fluctuations over the arbitration award and the annual meeting of the Company, but have now settled into a steady market, and prices are well maintained.

Prices as we go to press (August 15th):

Marconi Ordinary, £5 15s. od. (extra div.)

Marconi Preference, £5 os. od. (extra div.)

Marconi Marine, £3 5s. od.

American Marconi, £1 9s. 6d.

Canadian Marconi, 15s. 6d.

Spanish and General, 14s. od.

WANTED. "WIRELESS WORLD" numbers 6667/71. Fair price given.—Box "N" WIRELESS WORLD, 12 and 13, Henrietta Street, Strand, W.C. 2

INSTRUCTOR in Wireless Telegraphy wanted. Send copies of testimonials and state salary expected to the Principal Atlantic Wireless and Submarine College, Caherciveen, Co. Kerry.

PATENTS, Inventions, Trade Marks.—Advice and handbook free.—King's Patent Agency, Ltd., 165, Queen Victoria Street, London, E.C.4.

WANTED the following numbers of the "Wireless World":—April, June, 1913; June, July, 1917; January, February, March, April, May, September, 1918; February, 1919. Write with full particulars, price, etc., to Box N. Wireless Press Ltd., 12-13, Henrietta Street, Strand, W.C. 2.

TECHNICAL BOOKS. Second-hand and New Books on every conceivable subject. Catalogue free. State wants. Books sent on approval. Books bought.—FOYLE, 121/125, Charing Cross Road, London.

#### CHANGE OF ADDRESS.

Readers are requested to note that the address of The Wireless Press, Ltd., is now, 12 and 13, Henrietta Street, London, W.C.2.

Extra copies of the R34 chart published in this issue can be obtained from The Wireless Press, for 6d., post free.



# Company Notes.

## Marconi's Wireless Telegraph Company Ltd. REPORT OF DIRECTORS.

The Directors submit herewith the Accounts for the year ended 31st December, 1918.

The net profit for the year amounted to £597,938. 9s., which added to the balance brought forward from the last account, leaves to the credit of Profit and Loss account a sum of

of	...	...	...	...	...	...	...	...	...	...	£974,698 14 8
From this have to be deducted the following dividends:—											
On Preference Shares 7 per cent. paid on 1st February, 1919	£17,500	0	0								
On Ordinary Shares an interim dividend of 5 per cent. paid on 1st February, 1919	61,182	8	0								
											78,682 8 0
Leaving available for distribution a balance of	...	...	...	...	...	...	...	...	...	...	896,016 6 8

The Directors recommend payment of further dividends:—

On Ordinary Shares 20 per cent. for the year ended 31st December, 1918 (making 25 per cent. for the year)	£244,729	12	0								
On Preference Shares 15 per cent. for the year ended 31st December, 1918 (making 22 per cent. for the year)	37,500	0	0								
											282,229 12 0
Leaving a balance of	...	...	...	...	...	...	...	...	...	...	613,786 14 8
Of which it is proposed to transfer to General Reserve	...	...	...	...	...	...	...	...	...	...	150,000 0 0
And to carry forward to next account	...	...	...	...	...	...	...	...	...	...	£463,786 14 8

The General Reserve will then stand at £1,250,000.

There having been no settlement with any of the Government Departments in respect of any of the Company's claims arising out of the war or for services rendered during the war, no sum in respect of any of these claims figures in the year's accounts.

Following the usual custom, the Shares in Associated Companies and Patents are taken into account in the Balance Sheet at their cost price, viz., £1,365,109. 10s. 1d. The par value of the shares now stands at £2,345,965. 12s. 3d., exclusive of shares which have no capital denomination.

The Directors regret to record the death on 9th May last, of Mr. Henry Spearman Saunders, who had been a Director of the Company since April, 1899.

Since the last Ordinary General Meeting, Mr. Sidney St. J. Steadman and Sir Charles J. Stewart, K.B.E., have been appointed Directors of the Company. In accordance with Article 74 these gentlemen retire, and being eligible offer themselves for re-election.

The Directors retiring by rotation are Mr. William Walter Bradfield, Mr. Maurice Alfred Bramston, and Mr. Samuel Geoghegan, who being eligible, offer themselves for re-election.

The Auditors, Messrs. Cooper Brothers & Co., also retire, and offer themselves for re-appointment.

By order of the Board,  
H. W. CORBY,  
Secretary

MARCONI HOUSE,  
STRAND LONDON, W.C.2.  
24th July, 1919.

# MARCONI'S WIRELESS TELEGRAPHY COMPANY LIMITED.

## BALANCE SHEET, 31st December, 1918.

	£	s.	d.	£	s.	d.	Cr.
<b>To CAPITAL—</b>							
<i>Authorized—</i>							
1,250,000 Ordinary Shares of £1 each	1,250,000	0	0				155,070 4 9
25 per cent. Cumulative Participating Preference Shares of £1 each	250,000	0	0				821,371 17 10
							1,246,171 7 11
<i>Issued—</i>							
1,225,648 Ordinary Shares, fully paid	1,225,648	0	0				362,796 18 2
25,000 Preference Shares, fully paid	25,000	0	0				37,789 7 11
							9,611 12 4
To Bills Payable				1,473,648	0	0	
To Sundry Creditors				4,900	8	10	
To Reserve for Expenses Unpaid and Receipts in Advance and Other Credit Balances				338,519	15	1	
To General Reserve Account				360,681	9	3	
To Profit and Loss Account—				1,100,000	0	0	
Balance brought forward				376,763	5	8	
Profit for the year as per Account				507,938	9	0	
							974,698 14 8
To Contingent Liability on Shares in Associated Companies £57,862 10s. and Liabilities under Agreements.							£4,242,457 7 10
<b>By CASH AT BANKERS AND IN HAND</b>							
<b>By INVESTMENTS, FIXED DEPOSIT AND TEMPORARY LOANS AGAINST SECURITIES</b>							
<b>By SUNDRY DEBTORS, DEBIT BALANCES AND EXPENDITURE ON FOREIGN DEVELOPMENTS</b>							
<b>By STOCK AT COST OR UNDER AS CERTIFIED BY OFFICERS OF THE COMPANY</b>							
<b>By FREEHOLD WORKS AT DALSTON</b>							
<i>Deduct Mortgage</i>							
<b>By FREEHOLD PROPERTY, PLANT, MACHINERY AND BUILDINGS AT CHELMSFORD AND GENOA</b>							
<b>By LONG DISTANCE STATIONS IN ENGLAND AND IRELAND (INCLUDING STORES) AND MOVABLE PLANT AT OTHER PLACES</b>							
<b>By EXPENDITURE ON LEASEHOLD PREMISES, OFFICE FURNITURE AND FITTINGS, LONDON, CHELMSFORD AND FOREIGN AGENCIES</b>							
<b>By SHARES IN ASSOCIATED COMPANIES AND PATENTS</b>							
<i>Shares held in Associated Companies are of a par value of £2,345,665 12s. 3d.</i>							
SIDNEY ST. J. STEADMAN, Director.							
H. RIALI, SANKEY, Director.							

## PROFIT AND LOSS ACCOUNT for the year ending 31st December, 1918.

	£	s.	d.	£	s.	d.	Cr.
<b>To RENTS, RATES, INCOME AND OTHER TAXES, TRAVELLING, PUBLICITY, GENERAL EXPENSES AND WAR SUBSCRIPTIONS</b>				34,278	8	7	
<b>To SALARIES, CONTRIBUTION TO STAFF SUPERANNUATION FUND AND DIRECTORS' REMUNERATION</b>				94,416	12	11	
<b>To LAW CHARGES, PROFESSIONAL FEES AND PATENT EXPENSES</b>				20,999	0	4	
<b>To DEPRECIATION OF PLANT, MACHINERY, BUILDINGS AND FURNITURE</b>				18,461	0	0	
<b>To STATION EXPENSES</b>				2,169	7	7	
<b>To BALANCE BEING PROFIT FOR THE YEAR CARRIED TO BALANCE SHEET</b>				597,938	9	0	
							£766,262 18 5
<b>By PALANCE OF CONTRACTS, SALES AND TRADING ACCOUNT</b>							
<b>By TRANSFER, SHARE WARRANT AND OTHER FEES</b>							
							765,669 12 5
							563 6 0

We have audited the above Balance Sheet with the books in London and accounts from Rome. A large part of the Investments and Shares in Associated Companies are held abroad. Except as to a part held in Russia we have seen letters or certificates stating that they are held on behalf of this Company. We have obtained all the information and explanations we have required. In our opinion such Balance Sheet is properly drawn up so as to exhibit a true and correct view of the state of the Company's affairs according to the best of our information and the explanations given to us and as shown by the books of the Company.

LONDON, 24th July, 1919.

COPER BROTHERS & CO.,  
Chartered Accountants. } Auditors.

## COMPANY NOTES.

# MARCONI'S WIRELESS TELEGRAPH COMPANY, LIMITED.

## The Report of the Twenty-second Ordinary General Meeting.

The TWENTY-SECOND ORDINARY GENERAL MEETING of Marconi's Wireless Telegraph Company (Limited) was held on Aug. 8th at the Savoy Hotel, Mr. GODFREY C. ISAACS, the deputy chairman and managing director, presiding. On entering the meeting room Senatore Marconi, Mr. Isaacs, and the other members of the board were loudly cheered.

The CHAIRMAN.—Ladies and gentlemen, the war is at an end, but the duties and responsibilities of some have not yet ceased. Among that number is our illustrious chairman. Senatore Marconi, who is a peace delegate at the Paris Conference, is obliged to-day to attend this meeting in his personal capacity evincing the interest he has always shown in this company, and it therefore devolves upon me in such circumstances to preside. I now call upon the secretary to read the notice convening the meeting and the report of the auditors.

THE SECRETARY (Mr. H. W. Corby) accordingly read the notice and the report of Messrs. Cooper Brothers and Co., chartered accountants, appended to the balance-sheet.

The CHAIRMAN.—Ladies and gentlemen, with your approval I propose to waive the formality of reading the report and accounts. The balance-sheet and profit and loss account are before you and I will deal with the figures in so far as they call for comment.

### THE BALANCE-SHEET: RESERVE ACCOUNT INCREASED.

Turning, in the first instance, to the balance-sheet, the capital account is unchanged. The bills payable are represented by a reduced figure: the amount due to creditors is, in round figures, about £100,000 higher than it was at the end of 1917, due to the business in hand at the end of the year; and the same remarks apply to the next item, which largely represents amounts received on account in respect of contracts in hand, but uncompleted at the end of the financial year. The reserve account shows an increase of £100,000 in keeping with the resolutions passed at the last general meeting. On the credit side, cash at bankers, investments, moneys on deposit, and temporary loans show such increases as might be expected from the substantial profits resulting from the last year's trading. The sundry debtors, &c., is largely consistent with the bigger figures with which we are dealing. The stock on hand has increased by some £120,000, resulting from the considerable orders in course of fulfilment when the accounts were closed. Freehold property at Dalston is increased by reason of the annual payment in

reduction of mortgage under the terms of the mortgage agreement. Freehold property shows some increase after writing off the usual allowance for depreciation in consequence mainly of additional buildings having been erected at our Chelmsford works. The amount to the credit of long-distance stations is reduced by the usual writing off for depreciation; and the next item shows a small increase in consequence of some additions due to expansion of the business.

Shares in associated companies and patents figure, as usual, at cost, and at the end of the year showed a decrease of some £130,000 in round figures. The par value, exclusive of shares which have no capital denomination, showed a reduction of £320,000. These changes are due principally to the fact that we sold, by agreement, during the last year, the whole of our assets in the Compagnie Universelle de Télégraphie et de Téléphonie sans Fil to a new French company; the Compagnie Universelle went into liquidation and at the end of the year we had not taken up our holding in this new company. I shall have more to say about this transaction later and deal with it now only to explain in considerable part the reason for the reduction in the figures in the shares held in associated companies. The sum of £1,365,000 figuring in the balance-sheet at cost and as an asset should, I think, be accompanied by some information which will satisfy shareholders that the asset is a sound one. Were it expedient to give full particulars of the shares which we hold there is no doubt that no further information would be necessary, but it would be inconvenient to give this information in all cases, and therefore it is best to give none. It would, perhaps, suffice if I tell you that the figures at the present moment represent a par value of £2,587,970, at a cost of £1,713,800, and if we take our holding in the Marconi International Marine Communication Company and the Marconi Wireless Telegraph Company of America alone, at their respective quoted values, we exceed the figure which is represented to-day as being the cost of the whole of our shares in associated companies and of our patents. (Cheers). The cost of our patents, it may interest our shareholders to know, stands in our books at £80,500.

### THE PROFIT AND LOSS ACCOUNT: THE DIVIDENDS.

Turning now to the profit and loss account, the balance of contract sales and trading account amounts for the past year to £765,000, or some £229,000 more than for

the preceding year, and the net profit amounts to nearly £598,000, which is approximately £215,000 more than in 1917. Adding the balance brought forward, £376,000, we have available to the credit of profit and loss account £974,000. We have already paid 7 per cent. on the Preference shares and an interim dividend of 5 per cent. on the Ordinary shares, and subject to your passing the resolution which we shall submit to you later, we propose to pay a final dividend of 20 per cent. upon the Ordinary shares and 15 per cent. upon the Preference shares, to transfer to general reserve the sum of £150,000, and to carry to next account the sum of £463,786 14s. 8d. I think I should tell you, by the way, that we do not think this sum is subject to any excess profits duty in consequence of the profit made in the year 1912 and the substantial increase in capital which has taken place since that date.

I think these figures will be regarded by you as highly satisfactory. (Cheers). Together with the results of the previous years they clearly demonstrate the growth of our organization throughout the world, notwithstanding the fact that it has been extremely difficult to conduct a commercial business such as ours during a period of war. There is no doubt that whilst we have benefited from the war in some respects, our progress has been very considerably retarded in other directions, particularly in the development of foreign telegraph services. Now that peace is officially restored we have a great work in front of us, and we shall endeavour to make up for the time which we have lost.

#### PROGRESS OF THE AFFILIATED COMPANIES.

Our affiliated companies have been handicapped, of course, by similar conditions, but taking all things into consideration, we have not too much reason to complain.

The Marconi International Marine Communication Company, Limited, in which we have a very large holding, increased its capital in the early part of this year from £600,000 to £1,500,000, and issued to its shareholders 600,000 of the new shares at par, being one new share for every share held. This company took up the whole of the shares to which it was entitled. A dividend of 15 per cent. for the year ended December 31, 1918, has been paid upon the whole of the capital, including the new issue.

The Société Anonyme Internationale de Télégraphie sans Fil, which, as you will remember, is the Belgian Company, the control and assets of which we seized in 1914, continued to do its business under the direction of my colleague, Captain H. Riall Sankey, C.B., and myself. In recent months, however, I am glad to say, it has been possible for the head office in Brussels to take back its child into its own keeping. Its directors have declared dividends for the years during which it was not possible for the accounts to be made up. Five per cent. has been paid in respect

of the year ended December 31, 1914; 7½ per cent. for the year 1915, and 12½ per cent. for each of the years 1916, 1917, and 1918, making a total of 50 per cent. for the five years. I think you will agree that in all the circumstances this is a highly satisfactory result. (Cheers.)

In France, the Compagnie Universelle de Télégraphie et de Téléphonie sans Fil, as I have previously told you, has gone into liquidation, having sold the whole of its tangible assets to the Compagnie Générale de Télégraphie sans Fil. This company was formed at the beginning of last year with a capital of 12,500,000 francs, and may be said to control the wireless telegraph business of France and her colonies. With the approval of the French Government we subscribed for 40 per cent. of the shares, and have three representatives upon the board, of which, again, with the approval and wish of the French Government, I am one. The business of the Compagnie Générale has developed so quickly, and their orders from the French Government are so extensive, that it was found necessary to double their capital. The issue was made a few weeks back at a premium of 7½ per cent., and we have applied for and been allotted the full number of shares to which we were entitled. The Compagnie Générale paid for the period of February 5 to December 31, 1918, a dividend of 27.226 francs per 500 francs share, and 1.302 francs for each founder share. Of these founders' shares also we hold our proportion. These shares have no capital denomination.

The Compagnie Française Maritime et Coloniale de Télégraphie sans Fil, which hitherto has conducted the business of the French Mercantile Marine, paid for the year ended December 31, 10 francs per share of 100 francs and 93.75 francs per founder share, which also are shares without capital denomination. This company is now going into liquidation, and a new company under the auspices of the Compagnie Générale de Télégraphie sans Fil has been created which takes over the whole of the French Mercantile Marine, and will be placed in the same position in France as is the Marconi International Marine Communication Company (Limited) in this country.

The Amalgamated Wireless (Australasia) (Limited) has paid a dividend of 5 per cent. for the year ended June 30, 1918.

The Marconi Wireless Telegraph Company of America paid a dividend of 5 per cent. for the year ended December 31, 1918. This was a very conservative distribution on the part of that company, but, no doubt, the directors acted with wise discretion.

#### THE RUSSIAN COMPANY.

The Russian Company of Wireless Telegraphs and Telephones, as you are aware, has its head office in Petrograd, and I have no reliable information to give you about this business. I had, however, the advantage of

## COMPANY NOTES.

meeting in recent months one of the directors of that company, who had the good fortune of his journey from Russia being facilitated by those at present controlling the destinies of that great country. I can only repeat to you, for what it is worth, the information which he gave to me. He informed me that he left Petrograd in the month of May last year, when the managers of the company were well, and although business was being conducted under very difficult circumstances they were, nevertheless, extremely busy. They had received, considerable orders from the Russian Government, and to his knowledge had been paid in advance on account of those orders 1,750,000 roubles. Of course, what these roubles were, or what they are worth, or what they ever will be worth, I am not in a position to tell you.

In Norway, by arrangement with us, a Norwegian Wireless Telegraph Company has been formed; we hold a substantial interest in that company, and are represented upon the board.

### FORMATION OF A COMPANY IN CHINA.

In China a company has been formed under charter notified to the British Legation. It has a nominal capital of £700,000, which is to be subscribed as and when required conjointly in equal moieties by the Chinese Government and ourselves. We pass to this company our patent rights and designs, and receive in return one-third of the profits in each year until such time as we may be paid a substantial sum of money, which sum has been agreed in satisfaction of those patent rights and designs. We are therefore entitled, meantime, by reason of our shareholding and patent rights, to two-thirds of the profits of this Chinese National Company. The company has a monopoly of the supply and maintenance of all wireless telegraph apparatus in China. (Cheers.)

There are other companies in the course of formation in other parts of the world about which I hope to be able to say more to you next year.

### RECONSTRUCTION OF THE CANADIAN COMPANY.

Although the Marconi Wireless Telegraph Company of Canada has made good progress it has not yet been able to pay a dividend. We have long felt, as I think I have told you before, that some reconstruction of that company was necessary, and I am glad to be able to tell you that we have now agreed with the Canadian company that their capital, which consists of a million shares of \$5 each, shall reduce its capital by halving the nominal value of the shares, making their shares \$2½ each instead of \$5, and that 500,000 new shares of \$2½ each shall be created. An agreement has now been entered into under which we have agreed that we will purchase 400,000 of the new shares, and that the long outstanding indebtedness of the Canadian company to this company, which has always so severely handicapped the Canadian company,

shall be liquidated. The company, as a result of these arrangements, have a clean sheet and a substantial working capital. Subject to the general meeting of shareholders, which is being convened at once, approving these recommendations, as I have no doubt they will, they will be promptly put into execution. There was but one thing more in our opinion to ensure the successful future of the Canadian company, and that was an able and energetic managing director with knowledge of the wireless telegraph business. I am glad to be able to inform you that we have secured such a man in Mr. Arthur H. Morse, and the Canadian directors have accepted our recommendation and appointed him managing director. Unless the departures of steamers for Canada are still held up, he should be well on his way to take up his new duties. I shall be surprised and disappointed if we do not now see a marked improvement in the development of the Canadian company. (Cheers.)

In Italy we have continued to do a substantial business under the ever-able and energetic management of the Marquis Solari. In consequence of the war, however, we have not yet received any part of the fruits of the agreement which we entered into with the Italian Government, but we may now look forward to considerable revenue accruing to us from the share to which we are entitled of the receipts from the commercial wireless services conducted by the Italian Government.

The Compania Nacional de Telegrafia sin Hilos, the Spanish company, continues to progress. Its coast stations are commencing to get busy with ship and shore messages; there is already promise of a much larger traffic than in pre-war days. The commercial service with Germany and Austria continues, and it will soon be re-opened—if it has not already been re-opened—with Italy. In the spring of this year permission was received to commence a service with this country. Neither the Spanish station nor the station at our disposal in this country proved to be altogether satisfactory for the purpose of conducting an efficient telegraph service. The first week's traffics, however, were very promising, but a telegraph operators' strike in Madrid disorganized the traffic, causing considerable delays. The service is not now being pressed pending arrangements being completed for the provision of stations which will be able to be devoted to their work without interruption.

The Argentine company since the outbreak of war has been obliged to mark time. All preparations are now being pressed forward to complete the erection of a high-power station near Buenos Aires and another in this country for the conduct of a direct telegraph service at reduced rates. The development of the science in recent years encourages us in the belief that we shall be able to offer the

the public a rapid and reliable service at sub-service at reduced rates. The development of the science in recent years encourages us in the belief that we shall be able to offer the public a rapid and reliable service at substantially reduced rates. The fact that we are able to send messages to Sydney, New South Wales, a distance of over 12,000 miles, the "record" in wireless telegraphy, from a station built to communicate 3,000 miles furnishes some indication of the progress made in recent years. (Cheers.)

The Pan-American Company, which shareholders will remember was formed for the purpose of conducting telegraph services between North and South America, are also engaged in building a station in Buenos Aires to communicate with New York.

We are awaiting the official declaration of Peace in the United States of America for the high-powered stations in the United States to be re-transferred to private ownership, when direct telegraph services will promptly be opened between Europe and New York.

We have entered into an agreement with the Colombian Government under which we shall erect a station in Bogota which will serve as a centre for other useful developments towards creating a world-wide wireless telegraphic service.

#### ASSISTANCE OF THE FOREIGN OFFICE.

Ladies and gentlemen, so far I have been dealing with all our businesses and interests abroad which have been mainly responsible for the satisfactory results which appear in the accounts presented to you. We wish to acknowledge the very valuable assistance which has been afforded to us by our Foreign Office in very many of our negotiations abroad. We have never on any occasion asked for help in any part of the world without its having been given to us to the fullest extent that circumstances would allow. (Cheers.)

But I must now leave a bed of roses and deal with the more thorny aspects of our business at home.

#### THE COMPANY'S WAR SERVICES AND THE POSTMASTER-GENERAL.

I am sorry to tell you once more that we have not been able to arrive at any settlement with his Majesty's Postmaster-General in respect of the services which we have rendered during the war. I deeply regret that the Official Secrets Act and a sense of patriotism prevent my reading to you a full record of this company's services to the Empire from the very eve of the outbreak of war until the signature of Peace. It is a record, ladies and gentlemen, of which the company has every right to be proud, and which not only you, but the people of the whole Empire would warmly applaud could the book be opened. I think I have told you on previous occasions that a high official of the Admiralty had gone so far as to say that the British Navy would have been far less efficient had it not been for the Marconi Company, and he added that

there was no company which had rendered greater services to the Empire than ours. (Cheers and a voice: "Bravo.") Yet we have not been able to obtain anything approaching what we deemed a reasonable offer for such of the work which we have done, and for which payment could, and should, be made.

We have asked the Post Office to pay us for the 80,000,000 words which we intercepted and reported day and night since the outbreak of war to as many sometimes as 40 different addresses directed by the Government. This work was done under the most difficult of circumstances, either under direct instructions from the Government or at the company's suggestions, made as the result of its observations of altered enemy tactics. Enemy fixed and portable stations, Naval stations comprising service ships, submarines, and aircraft, have all had to be dealt with. We designed entirely new receiving apparatus to meet the continually changing circumstances and counteract enemy activities. Some of the ablest of the company's engineers devoted their whole time to this work. The nature of the interception work, owing to the absence of facilities for calling for repetitions, was very difficult, particularly when it is borne in mind that half of the traffic was in cipher. But we were further handicapped by the absence of knowledge as to which stations would be sending messages or with what wave-lengths they would work. Yet everything was carried out to the complete satisfaction and appreciation of the Government Departments served. Upwards of 8,000,000 words were in foreign languages, including Russian, German, Italian, French and Rumanian. All these messages were translated by us and delivered to the numerous addresses designated to us by the authorities.

Since our stations were returned to us after the Armistice we have been conducting work of a somewhat similar nature, but a much simpler and easier one, for another Government Department. After consideration that Government Department fixed 3d. per word, which was what they deemed to be a reasonable rate of pay for the nature of the work which we were doing. We accepted what the Government Department considered reasonable. But for the much more difficult and onerous work which I have just described, and for which we have to look for payment to the Post Office, we have not been able to obtain an offer of more than what amounts to approximately one and one-fifth of a penny per word. (Cries of "Shame.") And this is not only offered to us as remuneration for our services, but it is to cover also compensation for our having been deprived of the use of the whole of our stations except Clifden during the whole period of the war. (Shame.) This one and one-fifth of a penny per word left but a very small margin over and above our actual out-of-pocket expendi-

## COMPANY NOTES.

ture. We have made many attempts to arrive at a reasonable settlement, and have offered to accept terms substantially less than those which we are being paid and to which I have already referred.

We would have willingly made that sacrifice in order to ensure the good relations which it is the company's aim to maintain with all Government Departments, but all to no avail. In these circumstances, ladies and gentlemen, as painful as it is to have to sue a Government Department under Petition of Right, you will not be surprised that we have again been driven to commence new proceedings and are threatened once more with being forced into a Court of Law, expending large sums in legal costs and wasting the time of the important officials of the company, whose whole energy and time are required successfully to run the vast machinery of our world-wide organization.

### THE IMPERIAL CHAIN OF WIRELESS STATIONS : THE RECENT PROCEEDINGS.

And this leads me to the proceedings which have recently terminated. I do not want to take up time now by repeating at any length the history of the contract for the Imperial Chain of Wireless Stations, but I would remind you that the trouble commenced in 1910, when we asked for a licence to build stations at our own expense, creating a wireless chain of telegraph communication throughout the Empire, which resulted in the contract of 1912. This was followed by the contract of 1913, repudiated at the end of December, 1914. Negotiations continued for years. Terms of a new contract were offered to the company in substitution of the 1913 contract by way of settlement, which the company accepted. The draft contract, however, was never forthcoming, and finally we despaired of ever arriving at a settlement, and proceedings were taken under the Petition of Right. Judgment was given in favour of the company in March, 1918. The damages had to be assessed by an arbitrator; a Judge of the High Court was appointed, conditionally upon both sides agreeing that there should be no appeal, and the award has recently been announced. The hearing lasted 18 days, during which many of us had to sit continuously in Court and commence our day's work when the Court rose. Ladies and gentlemen, when you bear in mind that the Post Office contended that the value of the contract was £47,500, or in the most favourable circumstances £50,000, you will understand why, after years of negotiation, we were obliged to have recourse to a Petition of Right.

### THE CLAIM AND THE AWARD.

And now, ladies and gentlemen, before I go further, I must say a word or two as to how the claim submitted by us was compiled. After we obtained judgment we were desirous of going before the arbitrator and placing all facts and figures before him, leaving it to him to award us a *quantum meruit*.

The Post Office, however, said "No! You must define your claim." This it was impossible for us to do other than by a formula, in symbols, embracing all the conditions of the contract, subject to its being interpreted in the most favourable manner possible to us, and such estimates of percentages of traffics and traffic increases as we thought we might reasonably suppose might take place in the course of 28 years, the longest term provided by the contract. At best, of course, this formula could only be based upon hypothesis, and we had of necessity to claim all that was possible in the most favourable circumstances. This, however, did not satisfy the Post Office, and again they pressed for actual figures, but without the knowledge of the cable traffics we could supply no figures. Finally, however, the Post Office agreed to furnish us with the actual cable traffics. To these figures we merely applied our formula, as we were obliged to do, and it worked out to the large figure of the claim. We had no alternative but to submit this account, but we submitted it very reluctantly. It was, however, impossible for anybody to say that over the 28 years, had the contract been carried out, even this figure might not have been justified.

### THE POST OFFICE DEFENCE.

When we came into Court, and without having given us any previous intimation, the Post Office set up the defence—

(1) That between 1914 and 1919, even had the stations been erected, we should have been entitled to no royalties, because, they said, they would not have been allowed to conduct a commercial service during the war. As to whether this is true or not I leave it to you to form an opinion. You will take into consideration the fact that the cables were in a most congested condition—the whole country was crying out about the delay in the transmission of cable messages; that we as a private company were allowed to conduct commercial services at Clifden until some months after America entered the war; that this service was only stopped at the instance of the United States Government; and I do not think you will find it difficult to draw your own conclusions.

(2) The Post Office contended that subsequent to 1919 all the essential Marconi patents would have expired, and they could then conduct a service without any of the latter improvements which the company might introduce, or desire to introduce, and would consequently cease to pay any royalties to the company. I should say here, in parentheses, that this contention, if it stood alone, was ample justification for the mistrust which my company had expressed on the manner in which the Post Office intended to carry out the contract (hear, hear), for Mr. Herbert Samuel, when he obtained from us some modifications of the terms of the contract in 1913, had said that his object was to give

the country the benefit of some epoch-making invention should occasion arise. Every improvement or invention has emanated from or belongs to the Marconi Company, and some of these are certainly epoch-making. (Cheers.)

And, thirdly, the Post Office put forward this extraordinary proposition:—That the wireless chain of stations could never have secured the traffics for which the contract made provision and the Marconi Company anticipated for had it done so the cable companies would have suffered, and the Post Office would have increased the wireless tariffs in order to protect the cable companies. (Laughter.) Would that have been an honourable procedure towards the Marconi Company? And what about the public and the all-important industrial interests of the Empire? They mattered nothing to the Post Office. Their first duty, they think, is to protect the cable companies.

#### THE WITNESS CALLED BY THE POST OFFICE.

And now I must tell you something about the way in which the Post Office endeavoured to improve its eleventh-hour case. They called an engineer who had been in the employ of the Poulsen Company. He prepared overnight a specification which it was contended would enable the Post Office to construct stations without using any unexpired Marconi patents. The specification and the blue print which were produced proved the reverse. It is true that they provided for transmission by a Poulsen arc under the first Poulsen patent, which expired last year, but the rest was Marconi, except that they could avoid interference, it was contended, by using a secret Admiralty patent, which their witness swore the Admiralty had used most successfully for this purpose since 1905. He was an Admiralty expert, and said that he knew of nothing so efficient for its purpose. This contention was very serious, and had it succeeded might have cost our company over £600,000. I ask your particular attention to what it turned out to be. After some trouble our counsel succeeded in forcing the consent to break the seals of this secret patent. It proved to be identical with the provisional patent applied for by the Marconi Company in 1903. The witness who produced the secret patent and swore to its efficiency was in the company's employ in 1903. He was recommended by the company to the Admiralty, in response to a request, and entered Admiralty service at the end of 1903. He stated that he had communicated the invention comprised in our 1903 application to the Admiralty in conformity with the agreement which entitled the Admiralty confidentially to receive information as to the company's inventions. It happens that the witness had himself been one of the signatories to the company's provisional application in 1903—a fact, he said, he had forgotten. This provisional application, after full trial and tests by our experts, proved to be valueless, and

not worth a final specification at a cost of a £5 note. (Laughter.) So much for the valuable secret patent. The Judge said that the calling of this witness was a sheer waste of time. (Hear, hear.)

There are two other incidents of importance which I think it my duty to place before you. The Post Office, who put forward the contention that they could use a Poulsen arc for transmission for the Empire chain of stations, and could otherwise do without Marconi patents, desired to call a French Government witness to give evidence to that effect. A step better calculated to ruin the Marconi Company at home and abroad, had it succeeded, it would be difficult to conceive. The first step towards obtaining the French Government's assistance was taken by a member of Parliament who was primarily responsible for the delay in the construction of the Imperial chain of stations in 1912. You, ladies and gentlemen, may wonder why. And you may ask yourselves through whom and in what way is this gentleman associated with the General Post Office. The French Government with courtesy could not refuse to send over the officer in charge of the Eiffel Tower Station to give evidence. The Post Office witness—the Post Office representative—said he interviewed him, but he was not called as a witness. I will tell you why. He would not give the evidence the Post Office required of him; he would have disproved the Post Office's case; he was here for three days, and returned to Paris; but, nothing daunted, the Post Office persisted in its contention.

#### FRENCH OFFICIAL EVIDENCE.

We, fortunately, had private knowledge of this incident, and we called French official evidence. This proved (1) that the French Government had considerable experience of long-distance telegraphy; (2) that Poulsen arcs had proved a failure for commercial wireless telegraphy; (3) that the Poulsen arcs were being superseded in French stations by up-to-date inventions, which had proved to be far more efficient; (4) that the French Government could not build stations for commercial purposes without using the patents of the French company; (5) that the French company had the right of use of the Marconi Company's patents and the Marconi Company owned the British rights of all the French company's patents. (Loud cheers.) Ladies and gentlemen, the Post Office completely failed to make out their case. Their own witness, Mr. Swinburn, an eminent scientific expert, said that the Marconi Company had made great improvements in wireless telegraphy in recent years, and still led the world in the development of the art—their own witness, an independent expert witness. (Cheers.)

Mr. Justice Lawrence, in giving his award, said that it represented the full royalty which he thought the company would have received during the full term of 28 years specified by



## COMPANY NOTES.

the contract. This meant, after hearing all this evidence, that the learned Judge was satisfied that: (1) the specification submitted by the Post Office would not render the erection of the stations possible without using Marconi patents; (2) that the Poulsen arcs would not provide an efficient form of transmission for the purpose required; and that (3) the Post Office would have required to use Marconi patents for internal and external transmission and internal and external reception.

### AFTER THE AWARD.

Ladies and gentlemen, if the Post Office and the company had failed to arrive at an agreement in consequence of a genuine divergence of opinion as to the value of the contract, one might have hoped and expected that the learned Judge's award would have opened the way to a simple and straightforward course in the interests of the country. One might have thought that the Post Office would have said to the company, "Now that this matter is settled, and the value of the contract has been defined, the Imperial chain of stations has to be built as quickly as possible; the country must have the benefit of your inventions, your experience, and the £60,000 a year which you spend upon research. We do not want to throw away £600,000 of public money for nothing; let us make another attempt to arrive at an agreement which will avoid the loss of this large sum of money and give to the company a reasonable equivalent in its place." It was known to the Post Office that we had again offered to build the Imperial chain of stations at our own expense, as we had offered to do in 1910; that we had suggested, if Government control were still deemed necessary, an arrangement could be come to with the company by which this could be achieved, without losing the advantages of the stations being built and worked by private enterprise. The Post Office took no such course. They went to Parliament for a supplementary vote of £170,000, and the following morning caused an inspired announcement to appear in the *Daily Mail* to the following effect:—"The Post Office engineers are installing a system which they say is free of all existing Marconi patents, and no royalties will be payable to the Marconi Company." Ladies and gentlemen, I say without hesitation that this cannot be done (hear, hear); and after the hearing before Mr. Justice Lawrence the Post Office must know that it cannot be done. (Loud cheers.)

### THE "PROGRAMME" OF THE POST OFFICE.

What is it that they are proposing? Let us examine their programme. They say, "For transmission we will erect Poulsen arcs, the original patent of which expired last year. The French Government say, We have tried this; it is a failure. We are pulling out the Poulsen arcs. But that does not matter; we, the Post Office, will avoid paying Marconi royalties at any cost. For reception we will

use the expired Marconi patents. For avoiding interference we will employ the Admiralty secret patent—an abandoned Marconi invention of 1903." The Post Office engineers admitted that they knew little or nothing about the long-distance wireless telegraphy and had had no experience of it. They are going to start building the Imperial stations by experimenting with obsolete systems. What matters it to them that they throw away £600,000 of public money; that they delay the provision of an efficient Imperial chain of stations for another nine years; that the supplementary vote of £170,000 and further large sums be spent to no purpose; that other nations are contracting for the construction of stations embracing all the important scientific improvements discovered up to the latest moment? The art as it was known in 1904 is good enough, the Post Office thinks, for the British Empire. Will the British public think so? Will this watertight Government Department be allowed to adopt this suicidal policy, and, in its ineptitude, raise the price of telegrams to cover its failure, as it is proposing to raise the price of telephones? The Chinese, under recommendation of the British Foreign Office, are to have the benefit of the latest Marconi inventions, and of their research work year by year. The British Post Office will have none of it; what the company did 14 years ago will do for them, and they will pay no royalties to the Marconi Company.

### "THE CRUX OF THE WHOLE QUESTION."

That is the *crux* of the whole question—no royalties to the Marconi Company—and why? What has been the crime of the Marconi Company? When war broke out they placed their whole resources at the disposal of the country. They have rendered services surpassed by none. The stations being badly needed, self-interest was forgotten; the country's need came first, and they offered in September, 1914, to waive their royalties and build the Imperial stations, leaving it to the Government to pay them whatever they thought fit. The Post Office declined. In November, 1914, the company again offered to waive their royalties and to build the stations for a fixed price, which would have left them a profit far less than the amount of the recent award. The Post Office declined; they repudiated instead. In 1916 the company accepted the Government's offer to build the stations upon terms far less favourable to them than those of the 1913 contract. The draft contract was to be submitted by the Government immediately; it was never forthcoming. In 1917 and 1918 they again negotiated and endeavoured to agree to terms for another substituted contract. They could not agree; how could they? The Post Office valued the old contract at £47,500. The Arbitrator, one of his Majesty's Judges, says it was worth £1,200,000, or, reduced to a cash payment on December 31, 1918,

£590,000—equivalent to £606,000, approximately, in cash at the present time.

To-day we are again willing to negotiate, but the Post Office says, "The country shall lose its £600,000; it shall have worthless, obsolete stations, built by inexperienced Post Office engineers, but we will tell all the foreign Governments, your customers, that the British Post Office can do without Marconi patents; no royalties will be payable to the Marconi Company." "This marks a revolution in wireless services," the *Daily Mail* is caused to say.

#### A DEMAND.

Ladies and gentlemen, is not all the sufficiently conclusive evidence that a genuine divergence of opinion was not the cause of our failing to arrive at an agreement? Is it not clear that there is something else behind this inexplicable conduct of the Post Office? (Cheers.) I say emphatically that had the Post Office wanted to arrive at an agreement there would have been no petition of right, there would have been no arbitration, and there would have been no award. Their conduct and attitude ever since Mr. Herbert Samuel left office have been inexplicable, and have resulted in a great waste of public money. I demand that before more money is squandered upon the Imperial stations an inquiry be held to investigate the extraordinary procedure of the Post Office and elicit on whose guilty shoulders lies the responsibility for their attitude with regard to the Imperial chain of stations. (Loud cheers.) I may speak with feeling—I do speak with feeling—for should personal enmity of an individual at the Post Office exist against any individual of this company, I say emphatically that he is failing in the sacred trust he holds in allowing his animus to stand in the way of the interests of the country. (Hear, hear.) There is something rotten in the state of the Post Office which demands investigation. (Hear, hear.)

The war being over we now hope to arrive at settlements with the Admiralty, the War Office, and the Air Ministry in respect of the extensive use which has been made by each of them of many of our patents; but before we can proceed we have to await an arbitration, as agreed, with the Admiralty, in respect of the Lodge patent, which must be disposed of before it is possible to deal with matters as a whole. I trust it may be possible to dispose of all of them by the end of the year. It is a curious and significant fact that, although we have met with so much trouble in our relations with the Post Office, the relations we have throughout had with all the other Government Departments remain to-day, as they have always been, entirely satisfactory. (Cheers.)

#### IMPORTANT DISCOVERIES.

Very important discoveries have been made in respect of both wireless telegraphy and telephony in recent times, for which a num-

ber of new patents have been taken out and applied for. They are likely to have far-reaching consequences, the effect of which it is impossible at present to foretell. We have a number of the ablest and most experienced men in wireless telegraphy continuously engaged in research and experimental work, which more than justifies the very large annual expenditure which we devote to this important branch of our organization.

Ladies and gentlemen, the amount of the award was received on Tuesday last. In view of what I have said to you, we do not at present propose to touch it; we propose to wait a little. We shall have to call you together again ere long to consider some increase of our capital. We have considerable developments in view, for which provision must be made; there may be more within the next few weeks. We require a little more time for consideration. We may know better where we stand when we meet you again, in the autumn.

#### THE JOINT GENERAL MANAGERS.

Ladies and gentlemen, since we met last year, Mr. Henry William Allen has, at my request, resigned the secretaryship of the company. He held that position since the company was incorporated over 22 years ago. Some of you who are old shareholders may know what signal service he has rendered during all those years and how deeply we are all indebted to him. (Cheers.) Last year I had the pleasure of informing you that he and our manager, Mr. Walter William Bradfield, C.B.E., had been appointed members of the board; to-day I have pleasure in announcing that these two gentlemen have accepted the positions of joint general managers of the company. (Cheers.)

I regret to have to inform you of the loss which we have suffered recently by the death of Mr. Henry Spearman Saunders, who had been a director of the company since 1899.

#### NEW DIRECTORS.

I have to inform you that Sir Charles Stewart, K.B.E., who is known to all of you in connexion with the very important position which he has held for many years as Public Trustee, and Mr. Sidney St. J. Steadman have joined our board, and we look to them with great confidence to render us substantial assistance in the efficient discharge of the responsibilities which we carry in the conduct of this business. (Cheers.) Further, I have to inform you that the many members of our staff who joined the Services, or in other capacities were lent to the Government for the period of the war, have returned, or are returning, to their positions in the company. We owe to them, as we owe also to all those who were allowed to continue with the company to fulfil equally important duties, a warm recognition of all the valuable services they have rendered both to the company and to the country. (Cheers.)

## COMPANY NOTES.

Ladies and gentlemen, I have endeavoured to put before you all the important matters with which we have to deal as fully and at such length as I have thought necessary. I hope I have not detained you too long; if I have omitted anything, or if there is any further information required, I will answer any questions which shareholders may wish to put to me before formally moving the first resolution. (Loud cheers.)

Are there any questions, ladies and gentlemen? No one rising to speak, the CHAIRMAN, continuing, said:—Well, there being no questions, I will formally move, "That the report of the directors submitted, together with the annexed statement of the company's accounts at December 31, 1918, duly audited, be received, approved and adopted," and I will ask Captain Sankey to second it.

CAPTAIN H. RIALI SANKEY, C.B., R.E. (Retired)—Ladies and gentlemen, I beg to second the motion.

The motion was put to the meeting and carried unanimously.

Mr. HENRY W. ALLEN, F.C.I.S.—I have pleasure in moving, "That a final dividend of 20 per cent., equal to 4s. per share, less income-tax, upon the Ordinary shares, now issued and paid up, be and the same is hereby declared for the year ended December 31, 1916; that a final dividend of 15 per cent., equal to 3s. per share, less income-tax, upon the Cumulative Participating Preference Shares be and the same is hereby declared for the year ended December 31, 1918; that the said dividends be payable on August 25, 1919, to shareholders now registered on the books of the company and to holders of share warrants to bearer."

Mr. W. W. BRADFIELD, C.B.E.—I have pleasure in seconding that.

The resolution was unanimously passed.

### PROPOSED PRESENTATION TO SENATORE MARCONI AND MR. GODFREY ISAACS.

Mr. MAURICE A. BRAMSTON.—Mr. Chairman, ladies, and gentlemen, I will ask your permission to make a suggestion. I am not at all sure that Senatore Marconi, or Mr. Godfrey Isaacs—who have received no hint of my intention—will approve of my action, but I have some confidence that it will not be opposed by the shareholders on the other side of the table. Senatore Marconi is, as you know, the genius who has invented and perfected the system which bears his name. To his unremitting work the success of our company, so far as the technical side is concerned, is principally due. His world-wide reputation is of the highest, and he stands on a level with, if he does not excel, Edison and the greatest inventors of our time. (Cheers.) He has been a great benefactor to mankind—(hear, hear)—and we are all greatly honoured by our association with him. But although his business abilities are of no mean order, I do not think he could alone have achieved for the company such a supreme commercial position without assistance. Some nine or ten

years ago he was fortunate enough to secure the co-operation of Mr. Godfrey Isaacs, and both the Senatore and the shareholders are to be congratulated on the selection. Mr. Godfrey Isaacs has had a very strenuous year. (Hear, hear.) I venture to think that the magnificent position in which our company stands to-day is to be attributed in a large measure to his activities. (Hear, hear.) Of his brilliant abilities you are all aware, but those on the other side of this table do not perhaps know the infinite pains he takes in his work, of his great powers of organization and of his indefatigability. The suggestion I have to put before you is that you should recognize in a substantial way the services of the Senatore and of Mr. Godfrey Isaacs, and that you should authorize that their portraits should be painted at the expense of the company and placed in a suitable position at Marconi House. (Cheers.) I also suggest that replicas of the pictures should be presented to them for their respective homes. (Hear, hear.) The resolution which I have the pleasure and honour to propose is, "That full length portraits of Senatore Marconi and Mr. Godfrey Isaacs be painted at the expense of the company and placed in a suitable position at Marconi House, and that replicas of the portraits be presented to them in recognition of their invaluable services to the company." (Cheers.) I hope that some shareholder on the other side of the table will be good enough to second the resolution.

Mr. BALFOUR ALLEN.—I have great pleasure, indeed, in seconding the resolution which has just been proposed. I shall not detain you by adding anything to what the director has said as to the eminent services of Senatore Marconi and Mr. Godfrey Isaacs. I second the resolution.

Mr. MURRAY GRIFFITH.—As I have had the privilege for many years of counting among my friends Senatore Marconi and Mr. Godfrey Isaacs, it affords me great pleasure—I cannot say to second the resolution, as that has been already done—but of supporting it and of voicing the views of the shareholders on this side of the table. A mere portrait cannot convey to the shareholders, perhaps, the personality which surrounds our managing director. It is almost impossible for us here in this room to realize the extraordinary energy which he puts, and always has put, into his wonderful work for this company. Not only will the gift of a portrait come from you as an expression of your appreciation of Senatore Marconi and Mr. Godfrey Isaacs, but there are thousands of homes in England at this present moment who think with gratitude of the messages which have been flashed by your company and which have saved many and many a life, and, incidentally, many thousands of pounds. I am sure that we on this side of the table endorse every word that has come from the proposer of the resolution. The words of comfort which Mr. Godfrey

Isaacs has uttered are very satisfactory. When one read the statement in the *Daily Mail*, I must say for myself that I thought the whole of the organization was already done, but organization is a great thing. We have not only the invention, but we have also the organization. I have had some little experience with Government Departments, and I know that it takes times to perfect an organization, and it takes brains, too. (Hear, hear.) I do not wish to detain you, ladies and gentlemen. I am sure that the resolution meets with our heartiest approbation. Mr. Godfrey Isaacs does not require his personality to be spread in his family and amongst those who know him, but there will come a day when he will not be here; I feel sure, however, that the day will never come when his relations with the Marconi Company will be forgotten. (Hear, hear.) It will then be pleasant to his family to look back and think that the shareholders desired to show their appreciation of his services and to perpetuate his memory.

The resolution was unanimously carried.

The CHAIRMAN.—On behalf of Senatore Marconi and on my own behalf, I thank you very sincerely indeed, ladies and gentlemen, and I also thank my colleagues for this very thoughtful and very kind mark of appreciation, which I am sure Senatore Marconi and I will receive with the greatest possible satisfaction. Speaking for myself, and it is probable I am speaking very much as Senatore Marconi would speak, I have not been consulted about this. I have heard nothing about it until now, and it came to me as an utter surprise. Had I been consulted, I am afraid I should have had to tell my colleagues, as I tell you, that there is little probability of that portrait ever being painted, for I do not know whether any painter will have the patience to come to my office to paint me, and I shall certainly never have the time to go to him. But, however that may be, the kind thought and feeling on the part of both directors and shareholders will be ever present in my mind. Now, ladies and gentlemen, we must proceed with our work, for I am sure we are taking up more time than busy men can afford. I will therefore move: "That the directors, Mr. Sidney St. J. Steadman and Sir Charles J. Stewart, K.B.E., who retire in accordance with Article 74, as altered by special resolution, be re-elected directors of the company. That Mr. William Walter Bradfield, Mr. Maurice Alfred Bramston, and Mr. Samuel Geoghegan, who retire in accordance with Article 81, be re-elected directors of the company."

Mr. ALFONSO MARCONI.—I have very much pleasure in seconding that motion.

The motion was unanimously agreed to.

On the proposition of Mr. CROFT, seconded by Mr. CLAY, it was then resolved: "That

Messrs. Cooper Brothers and Co. be re-elected auditors for the ensuing year, and that their remuneration for auditing the accounts to December 31, 1918, be 700 guineas."

#### ALTERATION OF ARTICLES.

The CHAIRMAN.—Ladies and gentlemen, that, I think, concludes the business of the ordinary general meeting. The extraordinary general meeting is a very simple matter. We have had the number of our directors limited to 10 by our Articles since the company was incorporated. I need not remind you that the company to-day is a very different concern from what it was then. We all feel that we require some additional aid, and therefore it is that we put this resolution before you to give us power to elect two further gentlemen to our board, and in doing that we ask you if you will agree that our remuneration as directors shall not be curtailed on that account, but that the total remuneration of the directors shall be increased in proportion to the amount of the fees of the two additional directors. I do not want there to be any misunderstanding in submitting this resolution. We are not asking for any additional remuneration; we are only asking you not to take away from us any of our present remuneration and give it to the two new directors, but that you should increase the remuneration so as to provide them with the same amount of fees as we ourselves are at present receiving. I now move:—"That the Articles of Association of the company be altered in the following manner:—

"(a) By submitting the following article for Article 72, that is to say:—

"72. The number of the directors shall not be less than five nor more than 12, but the directors may act notwithstanding any vacancy in their body."

"(b) By substituting the following article for Article 77, that is to say:—

"77. The remuneration of the directors shall, as from the 1st day of January, 1919, be at the rate of £5,000 per annum, and in addition thereto in any year in which the dividend or dividends and / or bonus declared and paid for such year on the Ordinary shares of the company shall be in excess of £7 per cent. on the nominal value of such shares, the remuneration of the directors shall be increased by the sum of £250 in respect of each 1 per cent. paid by way of dividend and / or bonus on the Ordinary shares in excess of £7 per cent. as aforesaid. The remuneration of the directors shall be divided between the directors in such proportions as they may from time to time determine."

Mr. S. ST. J. STEADMAN.—I shall be happy to second that.

The resolution having been put to the meeting and carried unanimously, the proceedings terminated.