

50 MHz Dual Channel Oscilloscope PM3217

Operating Manual/Gebrauchsanleitung/Notice d'emploi

9499 440 21501
831017/3/05



I&E

Industrial & Electro-acoustic Systems Division



**Industrial &
Electro-acoustic Systems**

PHILIPS



SERVICE

Scientific & Analytical Equipment
 Test & Measuring Instruments
 Industrial Automation
 Advanced Automation Systems
 Welding

Scientific &
 Industrial
 Equipment
 Division

840412

TEST AND MEASURING EQUIPMENT

ESU321701.1.

SUPPLEMENT TO OPERATING MANUAL PM3217 9499 440 21501

This ESU replaces: --

ERRATA

Specifications

1.2.2. Frequency range	DC:0...50MHz(-3dB) AC:2Hz..50MHz(-3dB)	Derating in 2, 5 and 10mV settings is 0,3MHz/°C related to ambient temp. of 25°C. Shifting + or - 3div from screen centre.
Shift influence additional pulse aberrations	≤0,2div	
1.2.6. Deflection coefficient-LINE	>8div.	At nominal line voltage
1.2.8. LEVEL range	14div at int. trig. 2,8V at ext. trig.	+or- 7div ref. to screen centre. +or- 1,4V ref. to screen centre.

Technische daten

1.2.2. Frequenzbereich	DC:0...50MHz(-3dB) AC:2Hz..50MHz(-3dB)	0,3MHz/°C Verminde- rung im 2, 5 und 10mV Bereich, Referenz Temp. 25°C.
Schiebeeinflüsse zusätz- liche impulsverformungen	≤0,2 Teile	+3 teile verschoben auf Bildschirmmitte
1.2.8. Pegelbereich	14 Teile bei Int.trigg.; 2,8V bei Ext. trigg.;	+ oder - 7 Teile. + oder - 1,4V.

=====
Caractéristiques

1.2.2. Bande passante	DC:0...50MHz(-3dB) AC:2Hz..50MHz(-3dB)	Réduction en dia- tions 2, 5 et 10mV est 0,5MHz/°C, temp de référence 25°C.
Influence de déplacé dis- tortion d'impulsion add.	<u><</u> 0,2div	Déplacé + et - 3div au centre de l'écran.
1.2.8. Gamme de niveau	14div Interne 2,8V Externe	+ et - 7div de centre de l'écran + et - 1,4V de centre de l'écran

=====

50 MHz Dual Channel Oscilloscope PM3217

Operating Manual/Gebrauchsanleitung/Notice d'emploi

9499 440 21501
831017/3/05



PHILIPS

IMPORTANT

In correspondence concerning this instrument, please quote the type number and serial number as given on the type plate.

NOTE: *The design of this instrument is subject to continuous development and improvement. Consequently, this instrument may incorporate minor changes in detail from the information contained in this manual.*

WICHTIG

Bei Schriftwechsel über dieses Gerät wird gebeten, die genaue Typenbezeichnung und die Gerätenummer anzugeben. Diese befinden sich auf dem Leistungsschild.

BEMERKUNG: *Die Konstruktion und Schaltung dieses Geräts wird ständig weiterentwickelt und verbessert. Deswegen kann dieses Gerät von den in dieser Anleitung stehenden Angaben abweichen.*

IMPORTANT**RECHANGE DES PIÈCES DÉTACHÉES (Réparation)**

Dans votre correspondance et dans vos réclamations se rapportant à cet appareil, veuillez TOUJOURS indiquer le numéro de type et le numéro de série qui sont marqués sur la plaquette de caractéristiques.

REMARKS: *Cet appareil est l'objet de développements et améliorations continus. En conséquence, certains détails mineurs peuvent différer des informations données dans la présente notice d'emploi et d'entretien.*

CONTENTS

1. GENERAL INFORMATION	9
1.1. Introduction.	9
1.2. Characteristics	10
1.2.1. C.R.T.	10
1.2.2. Vertical or Y-axis	10
1.2.3. Horizontal or X-axis.	11
1.2.4. Main time base	11
1.2.5. Delayed time base	11
1.2.6. X Deflection.	12
1.2.7. Triggering of the main time base.	12
1.2.8. Triggering of the delayed time base.	12
1.2.9. Calibration generator	13
1.2.10. Power supply	13
1.2.11. Environmental characteristics	13
1.2.12. Mechanical data	14
1.2.13. Z-mod input.	14
1.3. Accessories.	14
1.3.1. Supplied with the instrument.	14
1.3.2. Accessory information	15
1.4. Principle of operation.	23
1.4.1. Y Channel	23
1.4.2. Main time base triggering	23
1.4.3. Main time base circuit	23
1.4.4. Hold-off circuit.	23
1.4.5. Z-axis	23
1.4.6. Delayed time base triggering	24
1.4.7. Delayed time base circuit	24
1.4.8. Alternate time base logic.	24
1.4.9. Power supply	24
2. INSTALLATION INSTRUCTIONS	25
2.1. Important safety instructions.	25
2.2. Removing and fitting the front cover.	25
2.3. Position of the instrument.	25
2.4. Local mains (line) connection and fuse protection	26
2.4.1. Battery operation	26
2.5. Earthing	26
3. OPERATING INSTRUCTIONS	27
3.1. General information.	27

3.2.	Switching on	27
3.3.	Explanation of controls and sockets	27
3.3.1.	C.R.T. and power controls	27
3.3.2.	Vertical channels	28
3.3.3.	Horizontal channel	28
3.3.4.	Main time base generator	29
3.3.5.	Delayed time base generator	30
3.3.6.	Miscellaneous	30
3.4.	Detailed operating information	31
3.4.1.	Preliminary settings of the controls	31
3.4.2.	Input coupling (AC/DC, 0)	31
3.4.3.	Use of probes	31
3.4.4.	Selection of chopped or alternate modes	31
3.4.5.	Differential mode	32
3.4.6.	Selection of trigger mode	32
3.4.7.	Trigger sources	33
3.4.8.	Time base magnifier	34
3.4.9.	Hold-off	34
3.4.10.	X-Y Measurements	34
3.4.11.	Using the delayed time base	34
4.	BRIEF CHECKING PROCEDURE	35
4.1.	General information	35
4.2.	Preliminary settings of the controls	35
4.2.1.	Trace rotation	35
4.2.2.	Use of probes	35
4.2.3.	Vertical channels	36
4.2.4.	Time base and triggering	36
5.	PREVENTIVE MAINTENANCE	38
5.1.	General information	38
5.2.	Removing the bezel and contrast plate (to clean the contrast filter)	38
5.3.	Recalibration	39

Operating Manual

1. General information

1.1 INTRODUCTION

The 50 MHz dual-channel oscilloscope PM 3217 is a compact, portable instrument, ergonomically designed to facilitate its extensive measuring capabilities.

The instrument provides both a main and a delayed timebase with provision for alternate timebase displays, comprehensive triggering facilities including peak-to-peak Auto, DC coupling and automatic TV waveform display.

A large 8 x 10 cm screen with illuminated internal graticule lines makes for easier viewing, and a 10 kV accelerating potential gives a high intensity trace with a well-defined spot.

The wide range of applications enabled by the above features is further extended by a versatile power supply that enables the instrument to be operated from different line voltages as well as from d.c. For field operation an optional battery version is also available.



Fig. 1.

1.2. CHARACTERISTICS

The insulation between the oscilloscope and line (mains) fulfils the safety requirements of IEC-348 for metal encased Class 2 instruments.

This instrument has been supplied in a safe condition. The present Operating Manual contains information and warnings that shall be followed by the purchaser to ensure safe operation and to retain the instrument in a safe condition.

- This specification is valid after the instrument has warmed up for 30 minutes (reference temperature 23°C).
- Properties expressed in numerical values with tolerance stated, are guaranteed by the manufacturer.
- Numerical values without tolerances are typical and represent the characteristics of an average instrument.
- Inaccuracies (absolute or in %) relate to the indicated reference value.

<i>Designation</i>	<i>Specification</i>	<i>Additional Information</i>
1.2.1 C.R.T.		
Type	D 14-125 GH/117	Rectangular tube face, mesh type, post accelerator, metal backed phosphor.
Measuring area	8 x 10 divisions	1 div. equals 1 cm
Screen type	P31 (GH)	P7 (GM) optional
Total acceleration	10 kV	
Graticule	Internal	Cont. variable illumination
Engravings	Centimetre divisions with subdivisions of 2 mm along the central axes.	
1.2.2 Vertical or Y-axis		
Display modes	Channel A only Channel B only A and B chopped A and B alternating A and B added	
Channel B polarity	Normal or inverted	
Response:		
Frequency range	DC: 0 50MHz (-3dB) AC: 2 Hz 50MHz (-3dB)	
Rise time	≤ 7ns	
Pulse aberrations	≤ ± 3% (≤ 5% pp)	Measured at 6 div. amplitude and applied rise time of ≥ 1 ns.
Additional aberrations 2,5 and 10 mV	0,15% per °C	Related to ambient temp. 25 °C
Deflection coefficients	2 mV/DIV 10 V/DIV	1-2-5 sequence
Continuous control range	1 : ≥ 2,5	
Deflection accuracy	± 3 %	
Input impedance	1 MΩ/20 pF	
Input RC time	0,1 s	Coupling switch to AC
Rated input voltage	42 V (dc + ac peak)	Test voltage 500 V (r.m.s.) According to IEC 348
Chopping frequency	≈ 500 kHz	
Vertical positioning range	16 divisions	
Dynamic range	24 divisions	For frequencies ≤ 10MHz
Visible signal delay	≥ 2 divisions	At 10ns

C.M.R.R. in A-B mode	≥ 40 dB at 1 MHz	After adjustment at d.c. or low frequencies
Cross talk between channels	-40 dB or better at 10 MHz	Both attenuators in the same setting
Instability of the spot position:		
Temperature drift	$\leq 0,3$ div/hour	

1.2.3 Horizontal or X-axis

Horizontal deflection can be obtained from either the Main time base or the Delayed time base or a combination of the two, or from the signal source selected for X-deflection. In this case X-Y diagrams can be displayed using A, B, the Ext input connector, or Line as a signal source for horizontal deflection.

<i>Display modes</i>	– Main time base	X deflection by:
	– Main time base intensified by delayed time base	
	– Main time base and delayed time base alternately displayed	– Channel A signal
	– Delayed time base	– Channel B signal
	– XY or XY/Y operation	– Signal applied to EXT connector of main time base
		– Line frequency

1.2.4 Main time base

Operation	Automatic	Possibility of automatic free-running in the absence of triggering signals
	Triggered	
Time coefficients	0,5 s/DIV 0,1 μ s/DIV	1-2-5 sequence
Continuous control range	1 : $\geq 2,5$	
Coefficient error	$\pm 3\%$	$\pm 5\%$ including x10 magnifier
Magnification	10x	
Max. effective time coefficient	10 ns/DIV	

1.2.5 Delayed time base

Operation	Delayed time base either starts immediately after delay time or is triggerable after the delay time, by the selected delayed time base trigger source	
Time coefficients	1 ms/DIV – 0,1 μ s/DIV	1-2-5 sequence
Continuous control range	1 : $\geq 2,5$	
Coefficient error	$\pm 3\%$	$\pm 5\%$ including x10 magnifier
Delay time	In steps variable with main time base. Continuously variable with 10-turn potentiometer between 0 x and 10 x the time coefficient of the main time base	
Incremental delay time accuracy	0,5%	
Delay time jitter	1 : ≥ 20.000	

<i>Designation</i>	<i>Specification</i>	<i>Additional information</i>
1.2.6 X Deflection		
Source	A, B, EXT, EXT ÷ 10 or LINE	As selected by trigger source switch, if push-button X DEFL. is depressed
Deflection coefficients	A or B: As selected by AMPL/DIV EXTERNAL : 0,2 DIV EXT ÷ 10 : 2V/DIV LINE 8 divisions at nominal line voltage.	
Deflection accuracy	± 10%	X 10 MAGN off
Frequency range	DC: 0 1 MHz (-3 dB) over 6 divisions	
Phase shift	≤ 3° at 100 kHz	
Dynamic range	24 divisions	For frequencies ≤ 100 kHz
1.2.7 Triggering of the main time base		
Source	Ch. A, Ch. B, Composite, External ÷ 10 and line	
Trigger mode	Automatic, normal AC normal DC, TV-line and TV frame	
Trigger sensitivity	Internal: 0,5 div (DC 5 MHz) 1 div (5MHz 50MHz) External : 150 mV (DC 5MHz) 200 mV (5MHz 50MHz) Ext. ÷ 10 : 1,5V (DC 5MHz) 2V (5MHz 50MHz)	
Trigger sensitivity T.V.	Internal: 0,7 div (sync. pulse ampl.) External: 0,15V (sync. pulse ampl.) Ext. ÷ 10: 1,5V (sync. pulse ampl.)	
Triggering frequency range	AUTO: 20 Hz..... ≥ 50 MHz AC: 5 Hz..... ≥ 50 MHz DC: 0 Hz..... ≥ 50 MHz	
Level range	AUTO: Proportional to peak-to-peak value of trigger signal. AC, DC: 8div. at Internal trigg. , 1,6V at external trigg. , and 16V at ext. ÷ 10	+ or - 4 div and + or - 0,8V referenced to centre of screen + or - 8V referenced to centre of screen
Triggering slope	Positive or negative going	
Input impedance	1 MΩ//20 pF	
Rated input voltage	42 V (dc + ac peak)	Test voltage 500 V (r.m.s.) According to IEC 348
Hold-off time	variable	

<i>Designation</i>	<i>Specification</i>	<i>Additional Information</i>
1.2.8 Triggering of the delayed time base		
Source	chA, chB, Composite, External, MTB.	
Trigger sensitivity	Internal: 2 div. (DC 50MHz) External: 400mV (DC 50MHz)	
Level range	12 div at Internal trigg. 2,4V at ext. trigg.	+ or - 6 div referenced to centre of screen + or - 1,2V
Other trigger specifications are identical to "triggering of the main time base" with the exception of the trigger modes EXT. ÷ 10, TV and AUTO.		
1.2.9 Calibration generator		
Output voltage	1,2 Vpp	Square wave
Accuracy	± 1%	
Frequency	≈ 2 kHz	
1.2.10 Power supply		
AC supply:	Double insulated	Safety class II, IEC 348
Nominal voltage range (on line-mains voltage adaptor)	110, 127, 220 or 240 Vac ± 10%	
Nominal frequency range	50 400 Hz ± 10%	
Power consumption	30 W max.	At nominal mains voltage
Battery supply:		
Voltage range	22-27 V dc	Battery minus (-) connected to chassis
Current consumption	1,1 A max.	
Capacity to earth	185 pF 27 pF	Measured with rubber feet on grounded metal plate of 1 m ² Measured 30 cm above grounded plate of 1 m ²
1.2.11. Environmental characteristics		
The environmental data are valid only if the instrument is checked in accordance with the official checking procedure. Details on these procedures and failure criteria are supplied on request by the PHILIPS organisation in your country, or by PHILIPS, SCIENTIFIC AND INDUSTRIAL EQUIPMENT DIVISION, EINDHOVEN, THE NETHERLANDS.		
Ambient temperatures :		
Rated range of use	+ 5°C ... +40°C	
Operating	-10°C ... +55°C	
Storage and transport	-40°C ... +70°C	
Altitude:		
Operating to	5000 m (15000 ft)	
Non-operating to	15000 m (45000 ft)	

Humidity	21 days cyclic damp heat 25°C –40°C, R.H. 95%
Shock	30 g: half sinewave shock of 11ms duration: 3 shocks per direction for a total of 18 shocks
Vibration	Vibrations in three directions with a maximum of 15 min. per direction, 5 – 55 Hz and amplitude of 0.7mm _{pp} and 4g max. acceleration. Unit mounted on vibration table without shock absorbing material.
Electromagnetic interference	Meets VDE 0871 and VDE 0875 Grenzwertklasse B.
Safety	IEC 348, class II

1.2.12 Mechanical data

Dimensions:

Length	445 mm	Handle and controls excluded
Width	335 mm	Handle excluded
Height	137 mm	Feet excluded
Weight	8,4 kg (18,5 lb) approx.	

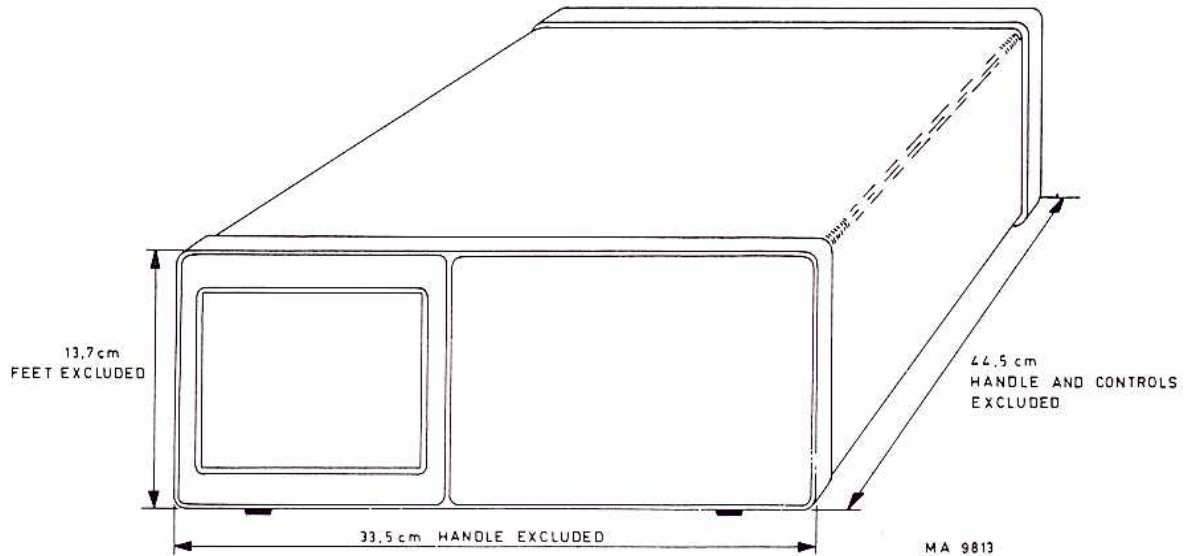

Fig. 2.

1.2.13. Z-mod input	DC coupled TTL compatible "1" is normal intensity "0" blanks display Min. pulse width required	20 ns
----------------------------	--	-------

1.3. ACCESSORIES

1.3.1. Supplied with the instrument

- Front cover
- 1 BNC 4 mm adaptor
- 2 Probes
- Operating manual

1.3.2. ACCESSORY INFORMATION

10:1 Passive probe PM 8927A

The PM 8927A is a probe with an attenuation factor of 10, designed for real-time oscilloscopes up to 100 MHz, with BNC input jack and 14 ... 40 pF input capacitance in parallel with 1 M Ω . The cable length of this probe is 1,5 metres.

Characteristics

Electrical

Attenuation		10x \pm 2 % (Oscilloscope input 1 M Ω)
Input resistance	d.c.	10 M Ω \pm 2 % (Oscilloscope input 1 M Ω)
	a.c.	See curve Fig. 4.
Input capacitance	d.c. and l.f.	11 pF \pm 1 pF (Oscilloscope input 1 M Ω \pm 5 % paralleled by 25 pF \pm 5 pF)
Input reactance	h.f.	See curve Fig. 4.
Useful bandwidth		See curve Fig. 6.
Max. rated input voltage		500 V d.c. + a.c. peak, derating with frequency. See Fig. 5. Oscilloscope input 1 M Ω and voltage applied between probe tip and earthed part of probe body. Test voltage 1500 V _{d.c.} during 1 s. at a temperature between 15 and 25 °C, a rel. hum. of 80 % at maximum and at sea level.
Check-zero button probe shell		Same function as 0 position of input coupling switch on oscilloscope.
Compensation range		14 ... 40 pF

Environmental

Probe operates within specifications over the following ranges:

Temperature	-25 °C to +70 °C
Altitude	Up to 5000 metres (15000 feet)
Other environmental data	Same as for any PHILIPS oscilloscope the probe is used with

Mechanical

Dimensions	Probe body 103 mm x 11 mm dia (max.) Cable length 1500 mm (or 2500 mm PM 8927AL) Correction box 55 x 30 x 15 mm incl. BNC
Mass	Incl. standard accessories 140 g.

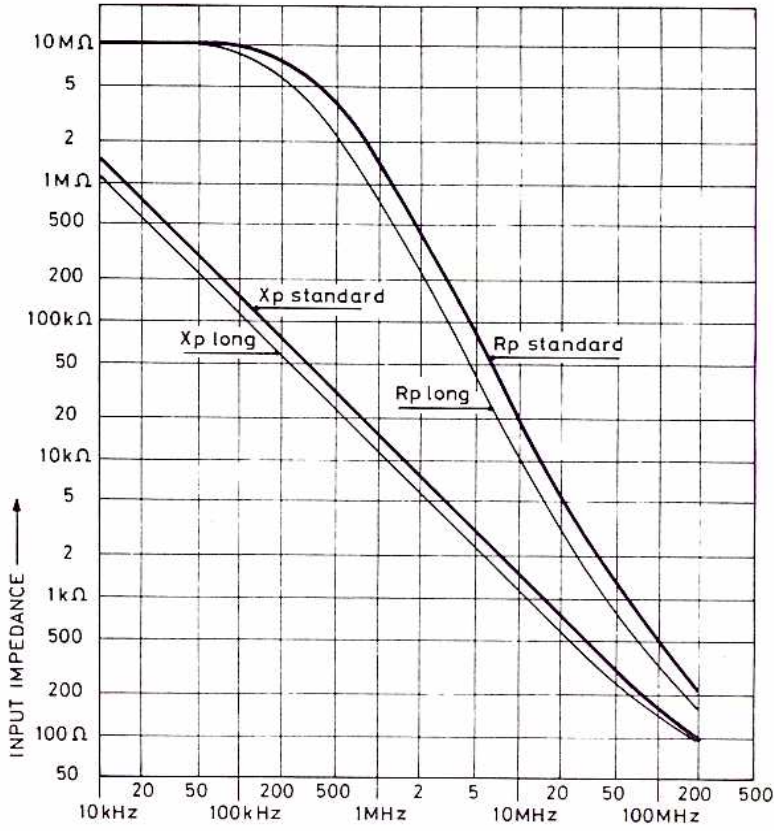

MAT 1362

Fig. 4.

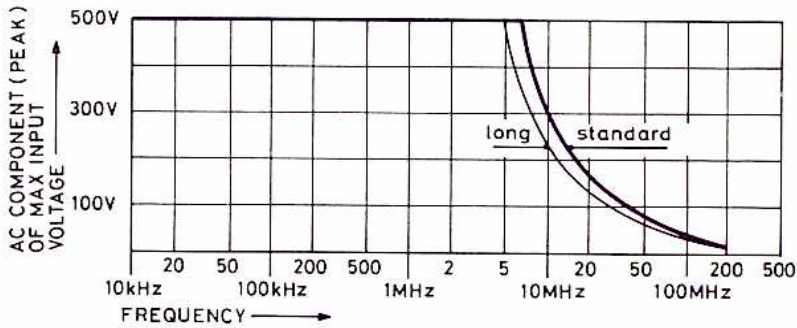

MAT 1363

Fig. 5.

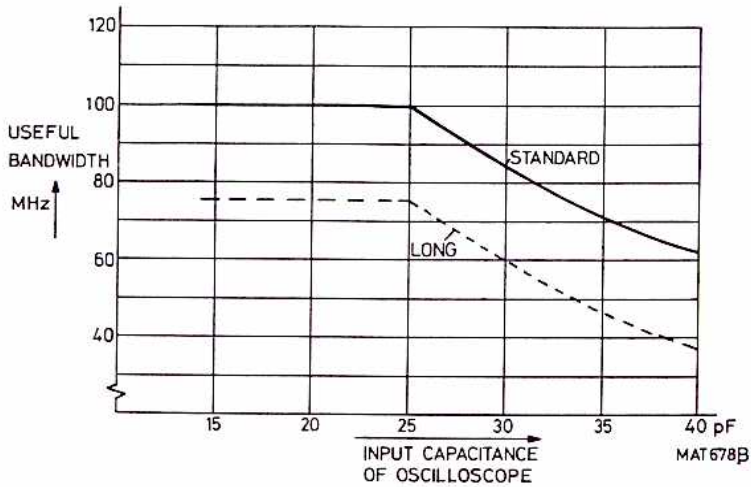

MAT 678B

Fig. 6.

Adjustments

Matching the probe to your oscilloscope

The measuring probe has been adjusted and checked by the manufacturer. However, to match the probe to your oscilloscope, the following manipulation is necessary.

Connect the measuring pin to the CAL socket of the oscilloscope.

A trimmer C2 (Fig. 13) can be adjusted through a hole in the compensation box to obtain optimum square-wave response. See Fig. 7, 8 and 9.

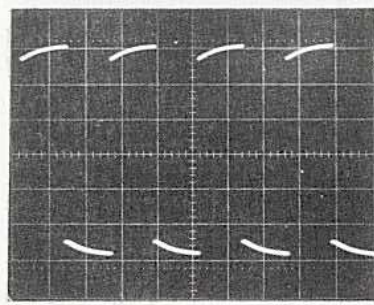

Fig. 7. *Over-compensation (adjustment C2)*

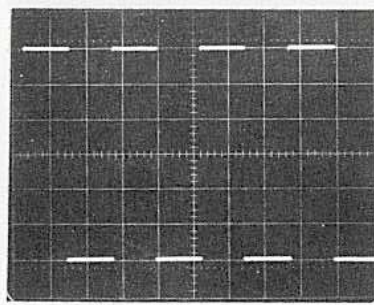

Fig. 8. *Correct compensation (adjustment C2)*

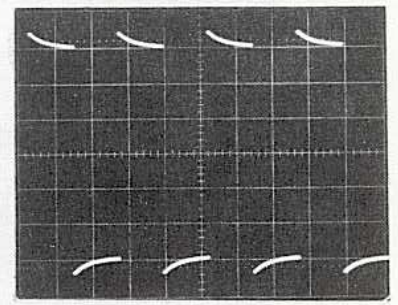

Fig. 9. *Under-compensation (adjustment C2)*

Adjusting the h.f. step response

The h.f. step response correction network has been adjusted by the manufacturer to match the oscilloscope input. For optimum pulse response, for separate delivered probes, the probe can be adjusted to match your particular oscilloscope. Later readjustment is only necessary if the probe is to be used with a different type of oscilloscope, or after replacement of an electrical component.

For the adjustment, proceed as follows:

Connect the probe to a fast pulse generator (rise-time not exceeding 1 ns) which is terminated by its characteristic impedance. Dismantle the compensation box. Set the generator to 100 kHz. Adjust R2 and R3 alternatively to obtain a display as shown in Fig. 10.

It is important that the leading edge is as steep, and the top is as flat, as possible. Incorrect settings of R2 and R3 give rise to pulse distortions as shown in Fig. 11 and 12.

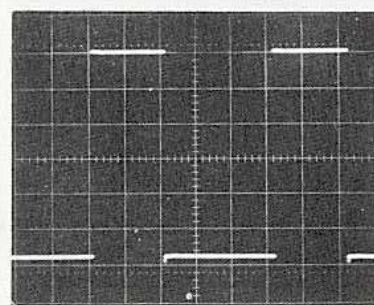

Fig. 10. *Preset potentiometers correctly adjusted*

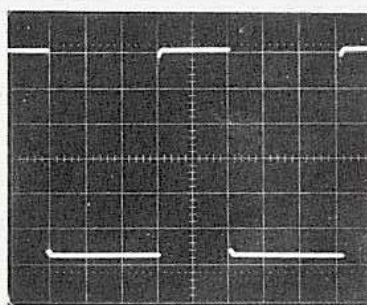

Fig. 11. *Rounding due to incorrectly adjusted potentiometers*

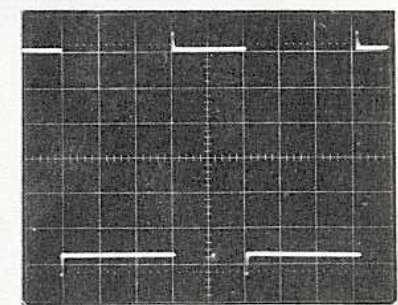

Fig. 12. *Overshoot due to incorrectly adjusted potentiometers*

Dismantling

Dismantling the probe (see Fig. 13)

The front part 11 of the probe can be screwed from the rear part 13. Item 11 can then be slid from 12 and 13. The RC combination 12 is soldered to 13. For replacement of 12 refer to the next section.

Dismantling the compensation box (see Fig. 13)

Unscrew the ribbed collar of the compensation box to the cable. The case 14 can then be slid sideways off the compensation box. The electrical components on the printed-wiring board are then accessible.

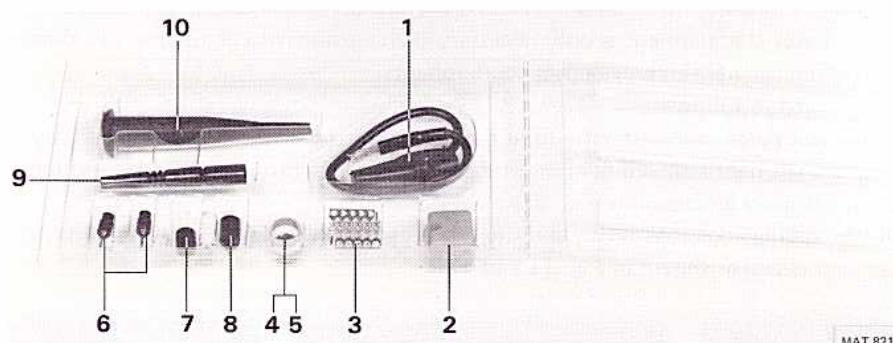
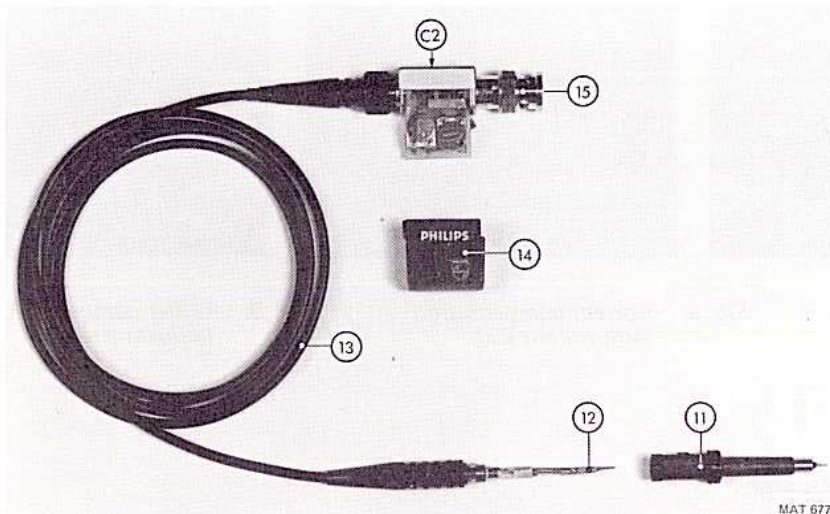

Fig. 13.

Replacing parts

Assembling the probe

A new RC network is slid over the cable nipple, after which the cable core is soldered on to the resistor wire. When a measuring probe is assembled, the RC network must be at dead centre in the probe tip.

Replacing the cable assembly

Dismantle the compensation box.

Unsolder the connection between the inner conductor and the printed-wiring board. Keep the frame of the compensation box steady and loosen the cable nipple with a 5 mm spanner on the hexagonal part. Replace the cable and fit it, working in the reverse order.

Replacing the BNC

Dismantle the compensation box.

Unsolder the connection to the printed-wiring board. Hold the frame of the compensation box firmly and loosen the BNC with a 3/8 inch spanner. Replace the BNC and fit it, working in the reverse order.

Replacing the probe tip

The damaged tip can be pulled out by means of a pair of pliers. A new tip must be firmly pushed in.

Parts list

Mechanical parts (see Fig. 13 and 14)

Items 1 to 10 are standard accessories supplied with the probe.

Item	Order number	Qty	Description
1	5322 321 20223	1	Earth cable
2	5322 256 94136	1	Probe holder
3	5322 255 44026	10	Soldering terminals which may be incorporated in circuits as routine test points
4	5322 532 64223	2	Marking ring red
5	5322 532 64224	2	Marking ring white
	5322 532 64225	2	Marking ring blue (not shown)
6	5322 268 14017	2	Probe tip
7	5322 462 44319	1	Insulating cap to cover metal part of probe during measurements in densely wired circuits
8	5322 462 44318	2	Cap facilitating measurements on dual-in-line integrated circuits
9	5322 264 24018	1	Wrap pin adaptor
10	5322 264 24019	1	Spring-loaded test clip
11	5322 264 24021	1	Probe shell with check-zero button
12	5322 216 54152	1	RC network
13	5322 320 14063	1	Cable assembly
14	5322 447 61006	1	Cap
15	5322 268 44019	1	BNC connector

Electrical parts

Item	Order number	Description
C1	—	Part of RC network (not supplied separately)
C2	5322 125 54003	Trimmer 60 pF, 300 V
R1	—	Part of RC network (not supplied separately)
R2	5322 101 14047	Potmeter 470 Ω , 20 %, 0.5 W
R3	5322 100 10112	Potmeter 1 k Ω , 20 %, 0.5 W

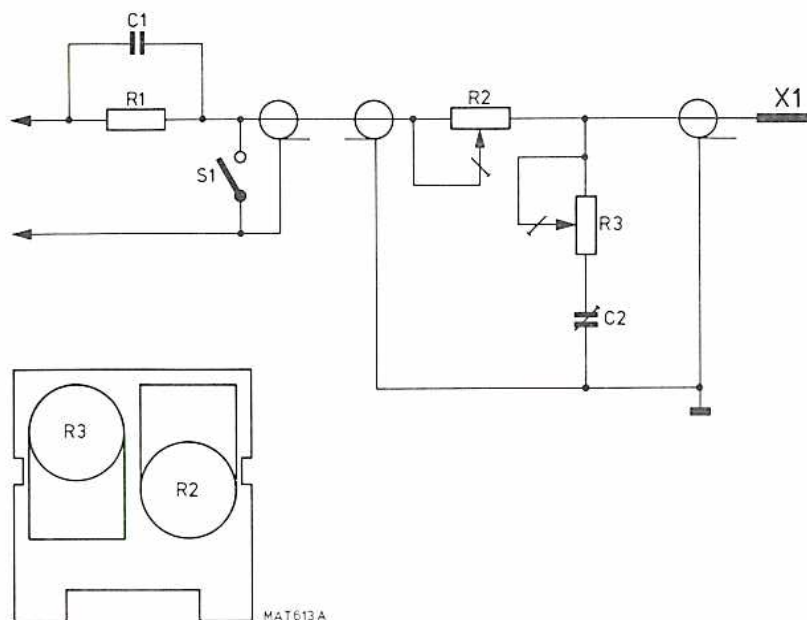
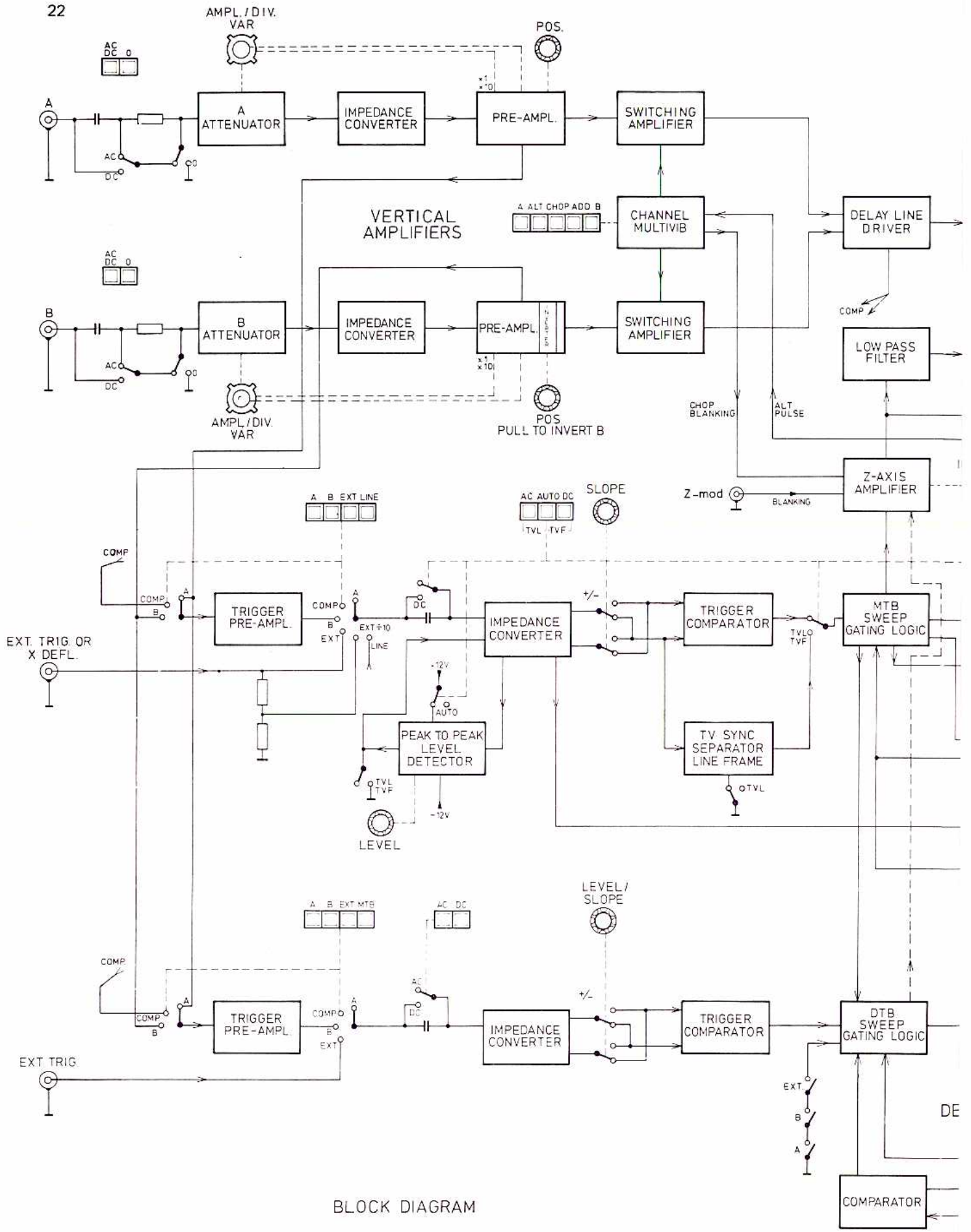

Fig. 14.



BLOCK DIAGRAM

Fig. 15. Block diagram

1.4. PRINCIPLE OF OPERATION (Fig. 15).

1.4.1. Y Channel

The vertical channels A and B for the signals to be displayed are identical, each comprising an input coupling switch, an input step attenuator, an impedance converter and a preamplifier with trigger pick-off.

A channel multivibrator, controlled by the display mode pushbuttons, switches either channel A or channel B to the final Y amplifier via the delay line. The channel multivibrator is operated by a pulse at the end of the sweep, and offers an uninterrupted display of the A and B waveforms in the ALT mode. In the ADD position, both switching amplifiers couple the signals through, thus adding channels A and B. By inverting the B channel amplifier (PULL TO INVERT B) the A – B mode is obtained.

The AMPL/DIV switches provide $\times 1$ or $\times 10$ gain control of the preamplifier, which offers in conjunction with the step attenuator a full range of deflection coefficients in a 1-2-5 sequence.

1.4.2. Main time base triggering

To initiate sweeps, trigger signals can be derived from the A and B vertical channel preamplifiers, from an external source, or internally from the mains supply (LINE triggering) as selected by the trigger source switch. Composite triggering (A and B depressed) is derived from the delay-line driver stage. The polarity of the trigger signal, negative or positive-going, on which the display will start is determined by changing the output polarity of the impedance converter.

With the AUTO switch depressed, the peak-to-peak level detector comes into operation. The peak-to-peak level of the signal then determines the range of the LEVEL control.

With AC or DC depressed, the range of the LEVEL control is fixed.

In the TVL and TVF modes the LEVEL control is inoperative and the TV sync separator is switched into circuit, thus initiating sweeps with line or frame pulses depending on the setting of the TVL and TVF switches.

1.4.3. Main time base circuit

For normal internal time base operation the horizontal amplifier is fed by sweeps from the time base circuit. With AUTO depressed, in the absence of trigger signals, the output of the sweep generator is fed back via the hold-off circuit and gate to its input. This causes sweeps to free-run and a resultant trace is displayed on the screen. As soon as the AUTO control circuit detects a trigger (i.e. a change in the output of the sweep-gating logic) the sweep is fed back to the sweep-gating logic. This causes the circuit to revert to the normal triggering mode in which sweeps are initiated only by trigger pulses at the input of the sweep-gating logic.

With AC or DC depressed, AUTO control is made inoperative. Sweeps are then only produced provided a trigger signal is present and the LEVEL control appropriately set.

The display can be magnified in the horizontal direction by increasing the gain of the final amplifier by a factor of $\times 10$ (also the X DEFL mode).

When the X DEFL pushbutton of the horizontal selection switch is depressed, the sweep generator output to the final amplifier is inhibited and the impedance converter is connected directly to the final amplifier. In this way, the signals normally selected for triggering, or an external source, can now be used for horizontal deflection.

1.4.4. Hold-off circuit

The hold-off stage, as its name implies, "holds-off" triggers from the input of the time base circuit until the trace has completely returned and the time base circuits are completely reset. The hold-off time can be decreased by turning the HOLD-OFF control clockwise.

1.4.5. Z Axis

The Z amplifier provides for the blanking of the trace during the fly-back and hold-off time. In addition, it blanks the sweep in the CHOP mode during the switching transients. More over the trace can be blanked by a signal applied to the external Z-mod input. The l.f. components of the blanking signal are modulated and demodulated before they are applied to the Wehnelt cylinder together with the a.c. coupled h.f. components.

1.4.6. Delayed time base triggering

To initiate sweeps, trigger signals can be derived from the A and B vertical channel preamplifiers, or from an external source as selected by the trigger source push button switch.

With both the A and B pushbuttons depressed simultaneously, composite triggering is derived from the delay-line driver stage of the Y amplifier channel. AC and DC coupling is provided to the impedance converter. The polarity of the trigger signal, negative or positive-going, on which the display will start, is determined by changing the output polarity of the impedance converter by the SLOPE switch.

With MTB selected, the delayed time base starts directly after the delay time. The DELAY TIME control in conjunction with the comparator determines the delay time for the delayed time base generator.

1.4.7. Delayed time base circuit

The delayed time base is operative unless its TIME/DIV switch is in the OFF position. It starts immediately after the delay time, or upon receipt of the first trigger pulse after the delay time.

The sawtooth signal derived from the main time base sweep generator is passed to a comparator where it is compared with an accurately adjustable d.c. voltage, controlled by the DELAY TIME control.

The comparator output is pulse-shaped and provides the required delay pulse for the sweep-gating logic of the delayed time base generator. A sawtooth voltage is then initiated.

The delayed sweep is reset by the hold-off circuit of the delayed time base (end of the sweep detection) or by the main time base.

It can be started again by the output signal of the comparator after the initiation of the next main time base sweep.

When pushbutton MTB of the horizontal deflection mode controls is selected, the part of the trace coinciding with the delayed sweep is intensified.

1.4.8. Alternate time base logic

In ALT TB mode an electronic switch enables main time base display and delayed time base display to be alternately traced on the screen.

The two displays can be separated by varying the voltage applied to the vertical amplifier, derived from the driving circuits of the electronic switch. This separation is symmetrically variable by means of the TRACE SEPARATION control on the front panel.

In the ALT TB mode the vertical channel multivibrator is controlled by a signal derived from the electronic switch.

In the vertical and horizontal ALT modes, successively are displayed on the screen, Channel A and main time base, Channel A and delayed time base, Channel B and main time base, Channel B and delayed time base.

1.4.9. Power supply

The mains (line) supply is transformed and rectified before being applied to a d.c. to a.c. converter.

When the instrument is operated from a battery supply, the battery output is connected directly to the d.c. to a.c. converter.

The output of the regulator is coupled to a transformer and rectifier which, after rectification, provides the -1.5 kV potential and the circuit supply voltages. The -1.5 kV is also multiplied to 8.5 kV to supply the required total accelerating voltage of ≈ 10 kV.

2. INSTALLATION INSTRUCTIONS

2.1. IMPORTANT SAFETY INSTRUCTIONS (IN ACCORDANCE WITH IEC 348).

Before connecting the instrument to the mains (line), visually check the cabinet, controls and connectors, etc., to ascertain whether any damage has occurred in transit. If any defects are apparent, do not connect the instrument to the mains (line).

CLAIMS

In the event of obvious damage or shortages, or if the safety of the instrument is suspect, a claim should be filed with the carrier immediately. A Philips Sales or Service organisation should also be notified in order to facilitate repair of the instrument.

The instrument must be disconnected from all voltage sources and any high voltage points discharged before any maintenance or repair work is carried out.

If adjustments or maintenance of the operating instrument with covers removed is inevitable, it must be carried out only by a skilled person who is aware of the hazards involved. In normal operation the double insulated power supply obviates the need for a safety ground.

Warning: It must be borne in mind that in all measurements the frame ground of the oscilloscope is raised to the same potential as that of the measuring ground probe connection. Neither the probe's ground lead nor the frame ground shall be connected to live potentials.

2.2. REMOVING AND FITTING THE FRONT COVER

For ease of removal and fitting, the front cover has been designed simply as a push-fit on the front of the instrument.

2.3. POSITION OF THE INSTRUMENT

The instrument may be used in any desired position. With the handle folded down, the instrument may be used in a folded sloping position. The characteristics in accordance with para. 1.2. are guaranteed only for normal position or when the handle is folded down. (Ensure that the ventilation holes in the rear cover are free).

Do not position the instrument on any surface which procedures or radiates heat, or in direct sunlight. The carrying handle can be rotated if the pushbuttons on its bearings are depressed.

2.4. MAINS (LINE) VOLTAGE SETTING AND FUSES

Before inserting the mains plug into the mains socket, make sure that the instrument is set to the local mains voltage.

Make sure that only fuses with the required rated current and of the specified type are used for replacement. The use of mended fuses and the short-circuiting of fuse-holders shall be avoided. The instrument shall be disconnected from all voltage sources when a fuse is to be replaced or when the instrument is to be adapted to a different mains voltage.

The instrument can be set to operate on the following mains voltages: 110 V, 127 V, 220 V and 240 V a.c. ($\pm 10\%$). These nominal voltages can be selected by means of the mains voltage selector, located at the rear (see Fig. 16).

For mains voltage selection, proceed as follows:

- Select one of the voltage ranges, as appropriate, by turning the selector with a screwdriver.

On delivery, the instrument is set to 220 V a.c.

A thermal fuse is fitted in the mains transformer; if replacement is necessary, it must be carried out only by a skilled person who is aware of the danger involved.

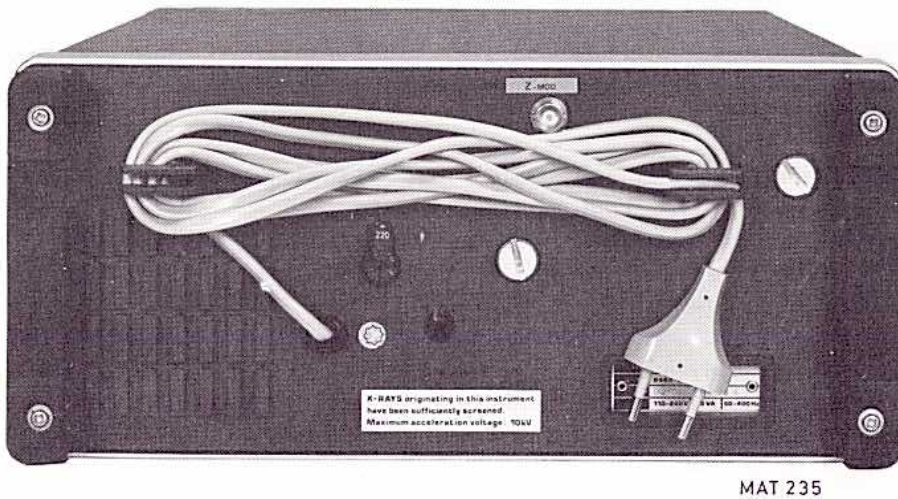

Fig. 16.

2.4.1. Battery operation

The instrument may also be powered from a battery supply of 22 V ... 27 V, connected to the battery input socket located on the rear of the instrument (see fig. 16.). The 24 V input is protected against reversed polarity of the battery input source. Protection is also given by a 1.4A delayed-action fuse located on the printed-wiring board of the power supply. This fuse shall be replaced only by a skilled person who is aware of the danger involved.

It is recommended that the instrument is not connected to the 24 V battery supply and the mains supply at the same time.

2.5. EARTHING

This instrument has a double-insulated mains transformer; in normal operation this facility obviates the need for a safety ground.

Warning: It must be borne in mind that in all measurements the frame ground of the oscilloscope is raised to the same potential as that of the measuring ground probe connection. Neither the probe's ground lead nor the frame ground shall be connected to live potentials.

3. OPERATING INSTRUCTIONS

3.1. GENERAL INFORMATION

This section outlines the procedures and precautions necessary for operation.

It identifies and briefly describes the functions of the front and rear panel controls and indicators, and explains the practical aspects of operation to enable an operator to evaluate quickly the instruments main functions.

3.2. SWITCHING ON

After the oscilloscope has been connected to the mains (line) voltage in accordance with sections 2.4. and 2.5., it can be switched on with the POWER switch.

The POWER switch is incorporated in the graticule ILLUM control on the front panel.

The associated POWER ON/OFF indicator lamp is adjacent to the ILLUM control/POWER switch.

When switching on the oscilloscope, it is immediately ready for use. With normal installation, according to section 2, and after a warming-up time of 30 minutes, the characteristics according to section 1.2. are valid.

Warning: The oscilloscope must never be switched on whilst any circuit board is removed.
Never remove a circuit board until the oscilloscope has been switched-off for at least one minute.

3.3. EXPLANATION OF CONTROLS AND SOCKETS (see fig. 17.)

The controls and sockets are listed according to their sections and a brief description of each is given.

3.3.1. Cathode-ray tube and POWER controls

ILLUM POWER ON	Continuously variable control of the graticule illumination; incorporates mains (line) switch. POWER ON pilot lamp indicates the ON state.
INTENS	Continuously variable control of the trace brilliance.
FOCUS	Allows beam to be focused for minimum spot size.
TRACE ROTATION	Screwdriver adjustment to align the trace with the horizontal graticule lines.

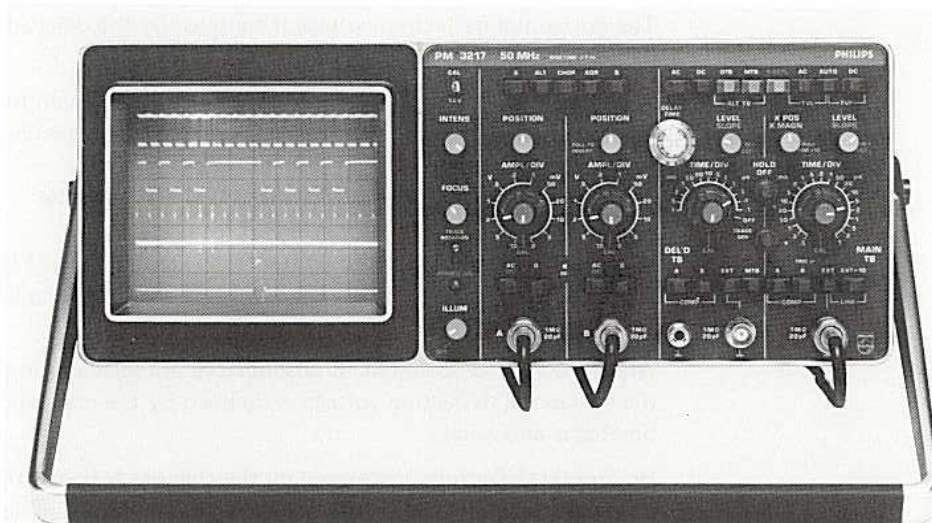

Fig. 17.

3.3.2. Vertical channels

Display mode switch

A – ALT – CHOP – ADD – B

A

ALT

CHOP

ADD

B

POSITION

PULL TO INVERT B

AMPL/DIV (outer-knob)

AMPL/DIV (centre-knob)

Input coupling switch

AC/DC – 0

AC (depressed)

DC (released)

0 (depressed)

A (1M Ω //20pF)

B (1M Ω //20pF)

Function

5-way pushbutton switch selecting the vertical display mode. With all buttons released, the ALT mode is in operation.

Vertical deflection is achieved by the signal connected to the input of channel A.

The display is switched over from one vertical channel to the other at the end of every cycle of the timebase signal.

The display is switched over from one vertical channel to the other at a fixed frequency. ($f \approx 500$ kHz)

Vertical deflection is achieved by the sum signal of channels A and B.

Vertical deflection is achieved by the signal connected to the input of channel B.

Continuously variable controls giving vertical shift of the display.

Push-pull switch combined with the channel B POSITION control. When pulled, channel B signal is inverted.

Step control of the vertical deflection coefficients, ranging from 2 mV/div up to 10 V/div in a 1-2-5 sequence.

Continuously variable control of the vertical deflection coefficients. Note that the deflection coefficient is calibrated only with the centre-knob switched to the CAL position (fully-clockwise).

Signal coupling; 2-way pushbutton switch

Coupling via a blocking capacitor

Direct coupling

Connection between input circuit and input socket is interrupted and the input circuit is grounded.

BNC socket for channel A input

BNC socket for channel B input

3.3.3. Horizontal channel

X deflection source switch

DTB MTB – XDEFL
└─ ALT TB ─┘

DTB

MTB

Function

Horizontal-deflection controls; 3-way pushbutton switch

The horizontal deflection voltage is supplied by the delayed timebase generator.

The horizontal deflection voltage is supplied by the main timebase generator. A portion of the trace is intensified when the delayed timebase is running.

The delayed timebase generator is switched off when the DELD TIME/DIV switch is in the OFF position.

If no buttons are depressed the effect is the same as the MTB button depressed (only the MTB LEVEL control is not operating in this situation).

DTB MTB
└─ ALT TB ─┘

When both the DTB and MTB pushbuttons are selected simultaneously, the horizontal deflection voltage is supplied by the main and delayed timebases alternately.

X DEFL

Horizontal deflection is achieved by the channel A signal, the channel B signal, the mains frequency signal or an external signal applied to the external input socket of the main time base.

X POS/X MAGN	Continuously variable control giving horizontal shift of the display; incorporates a push-pull switch, PULL FOR x 10, which increases the horizontal deflection coefficient by a factor of 10. The magnifier is also operative if an external X deflection signal is used.
TRACE SEP	Continuously variable control of the vertical space between the two time-base displays in the ALT.TB mode.

3.3.4. Main time base generator

LEVEL
SLOPE (IN +, OUT-)

Continuously variable control to select the level of the triggering signal at which the timebase generator starts. This control incorporates a push-pull switch, which enables choice of triggering on the positive or negative-going edge of the triggering signal. For TV triggering, select - for negative video signals and + for positive video signals.

Trigger mode switch

Function

AC - AUTO - DC
└ TVL ┘ └ TVF ┘

3-way pushbutton switch selecting the trigger mode. With all pushbuttons released AUTO sweep mode is in operation at a fixed range of the LEVEL control.

AUTO

A trace is displayed in the absence of trigger signals. The range of the LEVEL control is proportional to the peak-to-peak value of the triggering signal.

AC

Normal triggering and fixed range of the LEVEL control. The DC component of the trigger signal is blocked.

DC

Normal triggering and fixed range of the LEVEL control. The DC component of the trigger signal is passed.

AC AUTO
└ TVL ┘

Line synchronisation is obtained.

AUTO DC
└ TVF ┘

Frame synchronisation is obtained.

HOLD OFF

Continuously variable control of hold-off time

Trigger source switch

Function

A - B-EXT - EXT÷10
└ COMP ┘ └ LINE ┘

4-way pushbutton switch selects the trigger source, (or the source of horizontal deflection if X deflection source switch is depressed for X DEFL).

With all pushbuttons released, the effect is the same as the A button depressed.

A

Signal derived from channel A

B

Signal derived from channel B

A B
└ COMP ┘

Composite signal, derived after the electronic switch. Triggering occurs on the displayed waveforms (not usable with X DEFL).

EXT and EXT÷10

External signal derived via the adjacent 1 M Ω //20pF socket.

LINE (MAINS)

Signal derived from the line (mains) voltage. (Inoperable when instrument is battery-powered).

TIME/DIV (outer switch)

Selects the time coefficient from .1 μ s/div to .5 s/div in a 1-2-5 sequence.

TIME/DIV (inner knob)

Continuously variable control of the time coefficients. Must be switched to CAL position (i.e. fully clockwise) for the time axis to be calibrated according to the indication of the TIME/DIV switch.

1 M Ω - 20 pF

BNC socket for external triggering or horizontal deflection.

3.3.5. Delayed time base generator

LEVEL
SLOPE (IN +, OUT -)

Continuously variable control to select over a fixed range the level of the triggering signal at which the time base generator starts. This control incorporates a push-pull switch, which enables choice of triggering on the positive or negative going edge of the triggering signal.

Trigger mode switch

AC — DC

Function

2-way pushbutton switch selecting the trigger mode

AC

Normal triggering and fixed range of the LEVEL control. The DC component of the trigger signal is blocked.

DC

Normal triggering and fixed range of LEVEL control. The DC component of the trigger signal is passed.

DELAY TIME

Continuously variable vernier control of the delay time, together with the TIME/DIV controls of the main time base generator.

Trigger source switch

A — B — EXT — MTB
└COMP┘

Function

4-way pushbutton switch selects the trigger source and starting point of delayed time base. No pushbutton depressed has the same effect as the MTB button depressed.

A

Internal triggering
Signal derived from channel A.

B

Internal triggering
Signal derived from channel B.

A B
└COMP┘

Composite signal, derived after the electronic channel switch. Triggering occurs on the displayed waveform, after selected delay time.

EXT

Triggering on an external signal connected to the adjacent 1M Ω //20pF socket.

MTB

Internal triggering signal derived from the main time base to start the delayed time base immediately after the selected delay time.

TIME/DIV (outer switch)

Selects the time coefficient from .1 μ s/div to 1 ms/div in a 1-2-5 sequence. Incorporates an OFF position by which the delayed time base generator is switched off.

TIME/DIV (inner knob)

Continuously variable control of the time coefficients. Must be in the CAL position (i.e. fully clockwise) for the time axis to be calibrated according to the indication of the TIME/DIV switch.

1M Ω — 20 pF

BNC socket for external triggering signal.

3.3.6. Miscellaneous

CAL

Output socket supplying squarewave voltage \approx 2 kHz at an amplitude of 1.2 V p-p \pm 1%. To be used for probe compensation and/or checking vertical deflection accuracy.

DC POWER IN

Input socket at the rear of the instrument allows operation by an external battery supply. Rated supply voltage 22 V to 27 V, current capability > 1A.

LINE (MAINS) VOLTAGE
ADAPTOR

Must be set according to section 2.4. before the instrument is connected to the local mains voltage.

Z-MOD

Input socket for external Z modulation signal.

3.4. DETAILED OPERATING INFORMATION

Before switching on, ensure that the oscilloscope has been correctly installed in accordance with the instructions given in Section 2.

3.4.1. Preliminary settings of the controls

This procedure is a general indication of whether the oscilloscope is functioning correctly and provides a suitable starting point before any measurements are made.

Refer to Fig. 17. for location of controls.

Set INTENS and FOCUS controls in mid position.

Depress AUTO and select an average time coefficient between 10 μ s/div and 10 ms/div with the TIME/DIV switch. With all other pushbuttons normal (not depressed) channel A and channel B traces can be positioned on the screen with the relevant POSITION controls. Set the INTENS control for a display of medium brightness and adjust FOCUS control for well focused traces.

3.4.2. Input coupling (AC/DC, 0)

AC coupling (pushbutton depressed) is useful to block the d.c. component of a signal. Choice of AC limits the lower frequencies, causing low repetition rate sinewave signals to be attenuated and low repetition rate square-waves to be distorted. The degree of attenuation is determined by the input RC time (0.1s). Input RC time is extended by 10 if 10:1 passive probes are employed.

When switching to AC coupling it will take approximately five input RC times before the trace is stabilised to the average value of the input signal.

AC position measurements cannot be made with respect to ground.

0 position disconnects input source and short-circuits input of amplifier to provide zero signal check.

DC coupling (pushbutton released) provides for full range frequency input, i.e. down to d.c.

3.4.3. Use of probes

1:1 passive probes should only be used for d.c. and low frequencies.

Capacitive loading attenuates high frequencies or increases the rise-time of measurement signals (dependent on source impedance).

10:1 passive probes have less capacitive loading; usually about 10pF to 20pF. FET probes are superior, especially when measurements are to be taken from high impedance test points or at the upper frequency limit of the oscilloscope bandwidth.

10:1 passive probes must be properly compensated before use. Incorrect compensation leads to pulse distortion or amplitude errors at high frequencies.

For correct adjustment, the CAL output connection can be used

3.4.4. Selection of chopped or alternate modes

(A ALT CHOP ADD B)

In dual channel operations (CHOP or ALT depressed) the chopped mode (depress CHOP) must be selected for relatively slow sweep speeds (from .1 ms/div to .5 s/div) or at low repetition rates of sweeps occurring, even at high sweep rates. Selection of the ALTERNATE mode under these circumstances would make comparisons between waveforms difficult because traces would actually appear to be written one by one. However, when the display is fast enough to be interrupted by the chopping frequency the alternate mode must be selected (depress ALT), usually at sweep rates faster than .1 ms/div.

3.4.5. Differential mode

The A – B mode can be selected by depressing ADD and pulling the channel B POSITION control.

In measurements where signal lines carry substantial common mode signals (e.g. hum) the differential mode will cancel out these signals and leave the remainder of interest (A – B). The capability of the oscilloscope to suppress common mode signals is given by the CMR factor (see Fig. 18.).

To obtain the degree of common mode rejection as specified, channel A and B gains must first be equalised. This can be done by connecting both channels to the CAL output connector, and adjusting one of the continuous controls with the AMPL/DIV switch for minimum deflection on the screen.

When passive 10:1 probes are used a similar equalisation process is recommended by adjusting their compensating controls for minimum deflection.

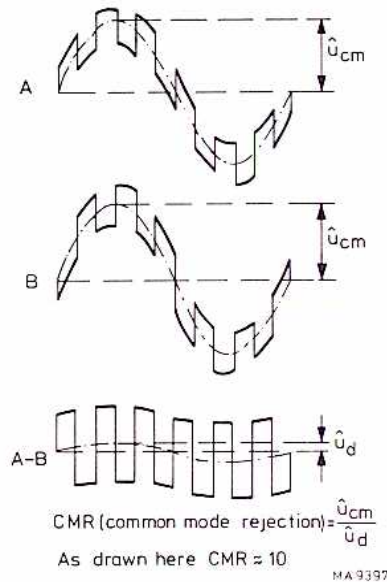

Fig. 18.

3.4.6. Selection of trigger mode

(AC AUTO DC)
 L TVL — L TVF —

The AUTO mode is most useful because it provides trace(s) on the screen even in the absence of trigger signals. Furthermore, for a signal amplitude larger than 1 division, this mode provides stable triggering independently of the position of the LEVEL control; its range is automatically adjusted to the peak-to-peak value of the signal selected for triggering.

In this way the setting of the LEVEL control is facilitated at small amplitudes of the trigger signal.

The AUTO mode cannot be employed for signals with low repetition rates (10 Hz or lower) because the sweeps would be able to free run in between triggers. Therefore, for low repetition signals normal triggering must be used (AC or DC depressed).

In normal triggering, sweeps are only initiated with a trigger signal applied and the LEVEL control set appropriately.

With AC or DC depressed the range of the LEVEL control is fixed (+ or –8 divisions or more at the extremes of the LEVEL control with respect to mid screen).

The DC component in the trigger signal can be blocked by depressing AC. This is useful when triggering must take place on a.c. signals superimposed on a large d.c. level.

With AC coupling, the level at which the display starts will change with alterations in the average value of the trigger signal. The trigger level is thus no longer referenced to signal ground. This may cause instability with waveforms that vary in time interval from cycle to cycle. Normally it is preferable to use the DC position.

Slope selection is made with pushbutton +/–. In TV mode – must be selected for negative video signals and + for positive video signals. The LEVEL control is inoperable in the TV mode.

No buttons depressed offers an extra mode of use, a trace is on screen in the absence of a trigger signal, but the LEVEL range is fixed.

3.4.7. Trigger sources

The main time base trigger sources can be selected by the front-panel TRIG or X DEFL pushbuttons.



- *Internal triggering* will be most commonly used because it requires only one signal (the input signal) to obtain stable triggering.
- *External triggering.* When tracing many signals it is advantageous to use an external signal for triggering. There is no need to set and reset the trigger controls (LEVEL, SLOPE and SOURCE) on changing the input signal. Furthermore the two A and B inputs remain free for examining waveforms.
- *Selection of trigger source.* In comparing waveforms that are a multiple of each other's frequency, always select the signal, that has the lowest repetition rate as the trigger source. Not doing so may lead to double pictures (chopped mode) or untrue time-shifts (alternate mode).
- *Composite triggering.* With internal triggering signals are obtained from either the A channel, the B channel preamplifier stages or, when COMP is selected by depressing both A and B pushbuttons, from the delay line driver stage that follows the electronic channel switch.

Composite triggering offers three advantages:

1. In differential mode (A – B measurements) triggering is derived from the differential signal. Triggering is not disturbed by common mode signals.
2. For one channel operation it is not necessary to switch trigger sources from A to B or vice versa.
3. In the alternate mode, it is possible to compare signals that are not related in time.

Note: When composite triggering is employed in dual channel operation (chopped or alternate), and there is only one signal applied (to A or B input), stable triggering cannot be obtained. This is only normal since the trigger source is also switched from A to B (see Fig. 19.).

- *Line (mains) triggering* is useful when the signal input is mains (line) frequency related.

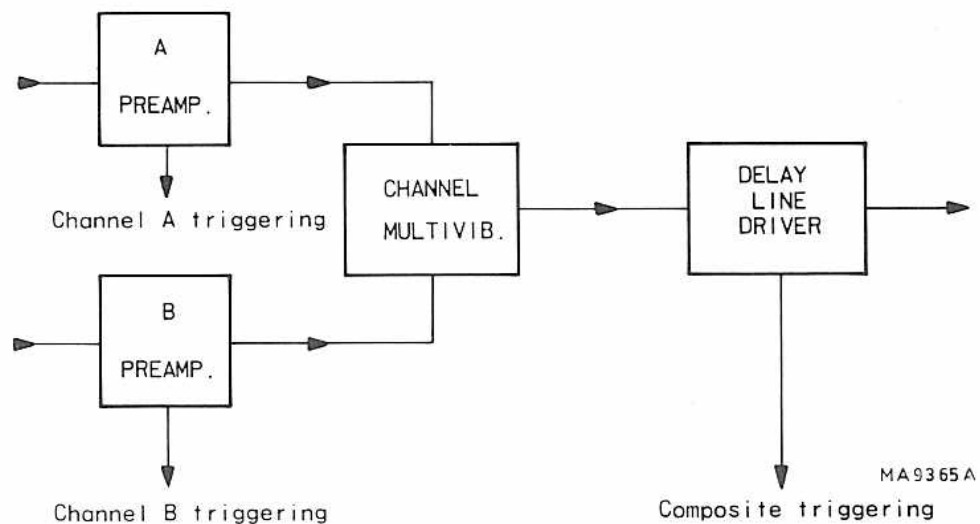

Fig. 19.

3.4.8. Time-base magnifier

The magnifier is operated by pulling the switch incorporated in the X position control. When this switch is in the x10 position, the time-base sweep speed is increased 10 times. The sweep time is therefore determined by dividing the indicated TIME/DIV value by 10.

3.4.9. Hold-off.

This control can be used to increase the sweep hold-off time.

3.4.10. XY Measurements

XY measurements are made with the TIME/DIV switch at EXT X DEFL, the source of horizontal deflection being selected by the TRIG or X DEFL pushbutton switch (A, B, EXT, EXT ÷ 10 or LINE)

XY measurements provide a useful means of making frequency or phase shift comparisons by displaying Lissajous patterns.

Measurements can be made up to 100 kHz with less than 3° phase error between horizontal and vertical channels

The sensitivity for the different XY modes is shown in the following table:

X deflection	Sensitivity
A	AMPL/DIV A ± 10%
B	AMPL/DIV B ± 10%
EXT	0.2 V/DIV
EXT ÷ 10	2 V/DIV
LINE	8 divisions

3.4.11. Using the Delayed time-base

The delayed time base can be used for the accurate study of complex signals. The delayed time base generator starts (TIME/DIV switch not at OFF) after the selected delay time and the delayed signal is intensified when the MTB pushbutton of the horizontal deflection controls has been selected.

The DELAY TIME potentiometer control enables the intensified portion to be shifted along the time axis. The duration of the intensified portion, its length, can be controlled in steps and continuously by means of the TIME/DIV controls of the delayed time base generator. When pushbutton DTB of the horizontal deflection controls is depressed, the intensified portion occupies the full width of the screen.

In the DTB position, the delay time (i.e. the interval between the starting points of the main time base and that of the delayed time base) is determined by the setting of the main time base TIME/DIV controls and the DELAY TIME control. The PM3217 is equipped with display switching. This offers the instrument user a simultaneous display of the signal on the two time scales provided by the main time base and by the delayed time base.

By selecting ALT TB, detailed examination of a certain portion of the main time base display is enabled by expanding the time interval of interest, using the delayed time base.

Expansion is achieved by selecting a correspondingly faster sweep for the delayed time base TIME/DIV control and positioning the time interval by the DELAY TIME potentiometer.

The part of the signal under detailed observation by the delayed time base also remains as an intensified portion of the main time base display. This not only facilitates the location of the required detail during dialling, but also serves as a visual indication of the portion of the overall trace being examined. Selection of ALT TB thus enables immediate correlation of the detail with the overall signal, which may be extremely complex, without the need to switch between MTB and DTB.

4. BRIEF CHECKING PROCEDURE

4.1. GENERAL INFORMATION

This check is intended to check the oscilloscope performance with a minimum of test steps and actions required.

It is assumed that the operator doing this test is familiar with oscilloscopes and its characteristics.

Warning: Before switching on, ensure that the oscilloscope has been installed in accordance with the instructions mentioned in chapter 2.

If this test is started a few minutes after switching on, bear in mind that test steps may be out of specification, due to insufficient warm up time.

To be sure that this will not happen, allow the full indicated warm up time.

All the check in this procedure can be made without removing the instruments covers.

4.2. PRELIMINARY SETTINGS OF THE CONTROLS

Before starting this check procedure, ensure that no input signals are connected, all pushbuttons are released and all switches are in the CAL position.

- Depress pushbutton A of the vertical display mode switches.
- Set the POSITION control of channel A to mid-position.
- Set the channel A AMPL/DIV switch to 20mV/DIV and its continuous control in the CAL position.
- Depress pushbutton AC of the input signal coupling switches.
- Depress pushbutton MTB of the horizontal display mode switches.
- Depress pushbutton AUTO of the MTB trigger mode switches.
- Push the MTB and DTB SLOPE switches incorporated in the LEVEL controls, for positive triggering.
- Set the MTB TIME/DIV switch to 0.2ms/DIV and its continuous control in the CAL position.
- Set the X POS control to mid-position.
- Set the HOLD OFF control fully clockwise.
- Depress pushbutton A of the MTB trigger source switches.

As the following procedure is identical for channels A and B only the procedure of channel A is described.

- Switch on the oscilloscope with POWER and check that the POWER indicator lights up.
- Set the INTENS control and FOCUS control to mid position.

4.2.1. Trace rotation

- Set the trace in the centre of the screen using the POSITION control.
- Check that the trace lies in parallel with the horizontal graticule lines, if necessary readjust the TRACE ROT preset.

4.2.2. Use of probes

The 10:1 passive probes must be properly compensated before use, to avoid pulse distortion or amplitude errors at high frequencies. For correct adjustment refer to chapter 1.3.2.

4.2.3. Vertical channels

- Connect the CAL output to the channel A input via the 10:1 passive probe
- If necessary, compensate the probe. Refer to chapter 1.3.2.
- Check that the amplitude of the square-wave is 6 divisions on the screen.
Channel B only:
 - Pull the POSITION control and check that the "PULL TO INVERT" switch inverts the signal.
 - Push the control to its normal position.
- Release pushbutton AC/DC of the input coupling switch to DC position.
- Check that the displayed signal shifts downwards because of the d.c. component.
- Depress the AC position again.

4.2.3.1. Vertical display mode switches

- Depress the ALT pushbutton.
- Set the MTB TIME/DIV switch to 50ms/div.
- Check that channel A and B are alternately displayed.
- Depress the CHOP pushbutton.
- Check that the channels A and B are simultaneously displayed.
- Set the TIME/DIV switch to 0.2ms/div.
- Apply the CAL output signal to both channel A and B inputs via two 10:1 probes
- Set the AMPL/DIV controls of channel A and B to 50mV/div.
- Set the signals from channels A and B in the vertical centre of the screen so that they completely overlap each other.
- Depress the ADD pushbutton.
- Check that the trace height is 4,8 divisions (A+B).
- Check that the POSITION controls of channel A and B influence the position of the added signal.
- Invert channel B by pulling "PULL TO INVERT" and check that a zero line is displayed.
- Check that by operating the variable AMP/DIV controls a squarewave appears.

4.2.4. Time-base and triggering

- Set the controls as indicated in Section 4.2.
- Depress the DC pushbutton of the DTB trigger coupling switches.
- Pull the SLOPE switch of the MTB and check that the MTB is triggered on the negative-going slope of the input signal.
- Depress the SLOPE switch of the MTB to return to positive triggering.
- Set the MTB TIME/DIV switch to 0.5ms/div.
- Pull the X MAGN switch combined with the X POS control and check that the horizontal deflection is magnified by a factor of 10.
- Depress the X MAGN switch to its normal position.
- Set the MTB TIME/DIV switch to 0.2ms/div.
- Set the channel A AMPL/DIV switch to 50mV/DIV.
- Set the DTB TIME/DIV switch to 50 μ s/DIV and its continuous control to the CAL position.
- Set the DELAY TIME control to 0.
- Set the start of the sweep at the zero line of the first division.
- Adapt the INTENS control to obtain a suitable display of the intensified part.
- Check that the intensified part starts at the beginning of the MTB trace.
- Check that the intensified part can be shifted over the MTB trace using the DELAY TIME control.
- Set the DELAY TIME control to 5.0 and check that the intensified part starts in the centre of the screen.
- Depress pushbutton A of the DTB trigger source switches.
- Check that the DTB (intensified part) is triggered on the signal derived from channel A; i.e. the DTB LEVEL control should be adjusted for a well-triggered intensified part.
- Pull the DTB SLOPE switch; the DTB should be triggered on the negative-going slope of the channel A signal.
- Depress the SLOPE switch of the DTB to return to positive triggering.
- Depress the MTB pushbutton of the DTB trigger source switches.
- Depress the DTB pushbutton of the horizontal display mode switches.

- Check that the intensified part now occupies the entire screen width.
- Depress the ALT TB pushbutton and check that both the MTB signal + intensified part and the full-width DTB signal are displayed.
- Adjust the vertical shift between the displays with the TRACE SEP control.
- Set the DTB TIME/DIV switch to OFF.
- Set the MTB TIME/DIV switch to X DEFL.
- Check that the horizontal and vertical deflection is determined by the channel A signal, and is 2,4 divisions.
- Set the MTB TIME/DIV switch to 0,5ms/div.
- Depress the DC and SINGLE pushbuttons.
- Set the MTB LEVEL control so that the NOT TRIG'D indicator is OFF.
- Depress the RESET pushbutton and check that the only one time-base sweep is displayed.
- Depress the AUTO position (AC+DC).
- Release SINGLE.
- Turn the HOLD-OFF control anti-clockwise and check that the intensity of the displayed signal decreases (max. hold-off time).
- Turn the HOLD OFF control clockwise for normal display.
- Disconnect the probes from the CAL signal and the oscilloscope is ready to use.

5. PREVENTIVE MAINTENANCE

5.1. GENERAL INFORMATION

This instrument generally requires no maintenance, as it contains no components that are subject to wear. However, to ensure reliable and troublefree operation, the instrument should not be exposed to moisture, heat, corrosive elements or excessive dust.

5.2. REMOVING THE BEZEL AND CONTRAST PLATE (TO CLEAN THE CONTRAST FILTER)

- Grip the lower corners of the bezel and gently ease it away from the front panel (Fig. 20.).
- Press the contrast filter gently to remove it from the bezel.
- When cleaning the filter, ensure that a soft cloth is used, free from dust and abrasive particles, to prevent scratches.



MAT 535

Fig. 20.

5.3. RECALIBRATION

From experience, it is expected that the oscilloscope operates within its specification for a period of at least 1000 hours, or for six months if used infrequently.

In addition, replacement of components may necessitate recalibration of the affected circuits. The checking and adjusting procedure can also be helpful in localising certain troubles in the instrument.

In some cases, minor troubles may be revealed and/or corrected by recalibration.

Complete checking and adjusting instructions are given in the Checking & Adjusting Section (Section 5 of the Service Manual). If only partial calibration is performed, refer to the interaction chart.

MODIFICATIONS

MODIFICATIONS

Sales and service all over the world

Alger: Bureau de Liaison Philips,
24 bis, Rue Bougainville,
El Mouradia, Alger; tel.: 565672

Argentina: Philips Argentina S.A.,
Casilla de Correo 3479, (Central), 1430 Buenos Aires;
tel. 542-2411/51 and 41-4071/78

Australia: Philips Scientific & Industrial
Equipment Division, Centre Court,
25 - 27 Paul Street, P.O. Box 119,
North Ryde/NSW 2113; tel. (2)888-8222

Bangladesh: Philips Bangla Desh Ltd.,
P.O. Box 62; Ramna, Dacca; tel. 234280

Belgie/Belgique: Philips & MBLE associated S.A.,
Scientific and Industrial Equipment Division,
80 Rue des Deux Gares 1070 Bruxelles;
tel. (2) 523.00.00

Bolivia: Industrias Bolivianas Philips S.A.,
Cajón Postal 2964, La Paz;
tel.: 351581

Brasil: Philips do Brasil Ltda,
Avenida 9 de Julho 5229, Caixa Postal 8681,
CEP 01407 - Sao Paulo (S.P.);
tel. 2821611

Service Centre:
Sistemas Profissionais
Rua Amador Bueno, 474,
Caixa Postal 3159 - S. Amaro,
CEP 04752 - Sto Amaro (S.P.);
tel. (11) 2476522

Canada: Philips Test and Measuring Instruments Inc.,
2375 Steeles Avenue West, Unit 126,
Downsview (Ontario) M3J-3A8;
tel. (416) 665-8470

Chile: Philips Chilena S.A.,
Division Profesional, Avda. Santa Maria 0760,
Casilla Postal 2687, Santiago de Chile; tel. 770038

Colombia: Industrias Philips de Columbia S.A.,
Calle 13 no. 51-39, Apartado Aereo 4282,
Bogota; tel. 2600600

Danmark: Philips Elektronik-Systemer A/S,
Afd. for Industri og Forskning, Strandlodsvej 4,
P.O. Box 1919, 2300 København S;
tel. (1) 572222

Deutschland (Bundesrepublik): Philips GmbH,
Unternehmensbereich Elektronik für
Wissenschaft und Industrie, Miramstrasse 87,
Postfach 310 320; 35 Kassel-Bettenhausen;
tel. (561) 5010

Ecuador: Philips Ecuador S.A.,
Casilla 4607, Quito; tel. 396100

Egypt: Resident Delegate Office of Philips Industries,
5 Sherif Street, Corner Eloui, P.O. Box 1687, Cairo;
tel. 754039/754257

Eire: Philips Electrical (Ireland) Ltd.,
Newstead, Clonskeagh, Dublin 14; tel. (1) 693355

España: Philips Ibérica S.A.E.,
Dpto Aparatos de Medida, Martinez Villergas 2,
Apartado 2065, Madrid 27;
tel. (1) 4042200

Service Centre:
Dpto Tco. de Instrumentación,
Calle de Albasanz 75, Madrid 17;
tel. (1) 2047100

Ethiopia: Philips Ethiopia (Priv. Ltd. Co.),
Ras Abebe Areguay Avenue,
P.O. B. 2565,
Addis Ababa; tel. 448300

Finland: See Suomi

France: S.A. Philips Industrielle et Commerciale,
Science et Industrie,
105 Rue de Paris, 93 002 Bobigny;
tel. (1) 830111

Great Britain: Pye Unicam Ltd., York Street,
Cambridge CB1 2PX; tel. (223) 358866
Service Centre:
Beddington Lane, Croydon, Surrey CR9 4EN;
tel. (1) 6843670

Greece: See Hellas

Hellas: Philips S.A. Hellénique,
54 Avenue Syngrou, P.O. Box 153,
Athens 403; tel. (1) 9215311

Hong Kong: Philips Hong Kong Ltd.,
Hopewell Centre, 27-29th floor,
No. 17, Kennedy Road, P.O. Box 2108,
Wanchai, Hong Kong;
tel. (5) 283298
Service Centre:
Hopewell Centre, 16th floor;
tel. (5) 283575

India: Philips India, Peico Electronics & Electrical Ltd.,
S&I Equipment, Shivsagar Estate,
Block "A", Dr. Annie Besant Road,
P.O.B. 6598, Worli, Bombay 400 018 (WB);
tel. 391431

Indonesia: P.T. Philips Development Corporation,
Department for Science and Industry Wisma PeDe,
Jalan Let. Jen. Haryono M.T. Kav. 17,
P.O.B. 2287, Jakarta-Selatan; tel. (21) 820808

Iran: Philips Iran Ltd., P.O.B. 1297, Teheran;
tel. 372081/5

Iraq: Philips Iraq W.L.L., Munir Abbas Building,
4th floor, South Gate, P.O. box 5749, Baghdad;
tel. 8880409

Iceland: Heimilsteaki SF, Saetún B, Reykjavik;
tel. 24000

Islas Canarias: Philips Ibérica S.A.E.,
Triana 132, Las Palmas, Casilla 39-41,
Santa Cruz de Tenerife

Italia: Philips S.p.A., Sezione S&I/T&M,
Viale Elvezia 2, 20052 Monza; tel. (39) 36351

Jamaica: Philips (Jamaica) Ltd.,
Savannah Av. & Washington Blvd.,
P.O. Box 61, Kingston - 6;
tel. 92 - 53041

Japan: See Nippon

Jordan: Philips Delegate Office,
P.O. Box 35268, Amman; tel. 43998

Kenya: Philips (Kenya) Ltd.,
01 Kalou Road, Industrial Area,
P.O.B. 30554, Nairobi; tel. 557999

Kuwait: Delegate Office of Philips Industries,
P.O. Box 3801, Safat, Kuwait; tel. 428678

Lebanon: Philips Middle East S.A.R.L.,
P.O. Box 11670, Beirut; tel. 285748/9

Malaysia: Philips Malaysia Snd Bhd.,
Professional Division,
Lot 2, Jalan 222, Section 14,
P.O. Box 2163, Petaling Jaya,
Selangor; tel. 774411/562144

México: Philips Mexicana S.A. de C.V.,
Div. Científico Industrial, Calle Durango 167,
Apartado Postal 24-328, Mexico 7 (D.F.);
tel. 544-9199/525-15-40

Morocco: S.A.M.T.E.L., Casa Bandoeng,
B.P. 10896, Casablanca 05; tel. 303192/302992

Nederland: Philips Nederland,
Hoofdgroep PPS, Boschdijk 525, Gebouw VB,
5600 PB Eindhoven; tel. 793333

Service centre:
Technische Service Prof. Activiteiten,
Hurksestraat 42, Gebouw HBK,
5652 AL Eindhoven; tel. 723094/722295

Ned. Antillen: Philips Antillana N.V.,
Postbus 523, Willemstad, Curaçao;
tel. 414071/74

New Zealand: Philips Electrical Industries of N.Z. Ltd.,
Scientific and Industrial Equipment Division,
68-86 Jervis Quay, P.O. Box 2097,
Wellington C1; tel. 735735

Nigeria: Associated Electronic Products (Nigeria) Ltd.,
Ikorodu Road, P.O.B. 1921, Lagos; tel. 900160/61

Nippon: NF Trading Co. Ltd.,
Kirimoto Bldg. 11-2,
Tsunashima Higashi 1 - Chome, Kohoku-ku,
Yokohama

Norge: Norsk A.S. Philips,
Dept. Industry and Telecommunication
Postboks 1, Manglerud, Oslo 6; tel. (2) 680200

Oesterreich: Oesterreichische Philips Industrie GmbH,
Abteilung Industrie Elektronik,
Partartgasse 34, A-1230 Wien;
tel. (222) 841611/15.

Pakistan: Philips Electrical Co. of Pakistan Ltd.,
El-Markz, M.A. Jinnach Road, P.O.B. 7101,
Karachi 3; tel. 70071

Paraguay: Philips del Paraguay S.A.,
Av. Artigas 1497,
Casilla de Correo 605, Asunción;
tel. 291924

Perú: Philips Peruana S.A.,
Av. Alfonso Ugarte 1268,
Apartado Aereo 1841, Lima 100; tel. 326070

Philippines: Philips Industrial Development Inc.,
2246 Pasong Tamo, P.O.B. M.C.C. 911,
Makati, Metro, Manila; tel. 868951/868959

Portugal: Philips Portuguesa S.A.R.L.,
Av. Eng. Duarte Pacheco 6, Apartado 1331, Lisboa 1000;
tel. (19) 683121

Service Centre:
Serviços Técnicos Profissionais, Outurela,
2795 Linda-a-Velha; tel. (19) 683121

Saoudi Arabia: Delegate Office Philips Industries,
Sabreen Bldg., Airport Road, P.O. Box 9844,
Riyadh; tel. 477808/4778453

Schweiz-Suisse-Svizzera: Philips A.G.,
Allmendstrasse 140, Postfach, CH-8027 Zürich;
tel. (1) 4882211/4882629

Singapore: Philips Singapore Private Ltd.,
Lorong 1, Tao Payoh, 1st floor,
P.O. Box 340, Toa Payoh Central Post Office,
Singapore 1231; tel. (2) 538811/537622

South Africa: South African Philips (Pty) Ltd.,
2 Herb Street, New Doornfontein, P.O.B. 7703,
Johannesburg 2000; tel. (11) 6140411

South-Korea: Philips Electronics (Korea) Ltd.,
G.P.O. Box 3680, Seoul; tel. 794 5011/5

Suomi: Oy Philips AB.,
Kaivokatu 8,
P.O. Box 10255,
SF-00101 Helsinki 10; tel. 17271
Service Centre:
P.O. Box 11, SF-02631 Espoo 63;
tel. (0) 523122

Sverige: Philips Försäljning AB,
Div. Industri Elektronik, Lidingövägen 50,
Fack, S11584 Stockholm; tel. (8) 635000

Syria: Philips Moyen-Orient S.A.R.L., Rue Fardoss 79,
Immeuble Kassas and Sadate, B.P. 2442, Damas;
tel. 118605/221650

Taiwan: Philips Taiwan Ltd.,
San Min Building, 57-1 Chung Shan North Rd., Sec. 2,
P.O. Box 22978, Taipei;
tel. (2) 5631717

Tanzania: Philips (Tanzania) Ltd.,
P.O. Box 20104, Dar es Salaam; tel. 29571

Thailand: Philips Electrical Co. of Thailand Ltd.,
283 Silom Road, P.O. Box 961, Bangkok 5;
tel. 233-6330/9

Tunisia: S.T.I.E.T., 32 bis, Rue Ben Ghedhahem,
Tunis; tel. 244268

Türkiye: Türk Philips Ticaret A.S.,
Posta Kutusu 504, Beyoglu,
Istanbul 1; tel. 435910

United Arab Emirates: Philips Middle East B.V.,
Dubai International Trade Centre, Level 11,
P.O. Box 2969, Dubai; tel. 475267

Uruguay: Industrias Philips del Uruguay S.A.,
Avda Uruguay 1287, Casilla de Correo 294,
Montevideo; tel. 915641

U.S.A.:

Philips Test and Measuring Instruments Inc.,
California, Garden Grove 92645

12882 Valley View Street, Suite 9;
tel.: (213) 594-8741/(714) 898-5000

California, Milpitas 95035

489 Valley Way;
tel. (408) 946-6722

Florida, Winter Park 32789

1850 Lee Road, Suite 229;
tel. (305) 628-1717

Georgia, Norcross 30071

7094 Peachtree Industrial Blvd., Suite 220;
tel. (404) 586-0238

Illinois, Itasca 60143

500 Park Blvd., Suite 1170;
tel. (312) 773-0616

Massachusetts, Woburn 01801

21 Olympia Avenue;
tel. (617) 935-3972

Minnesota, Minneapolis 55420

7801 Metro Parkway, Suite 109;
tel. (612) 854-2426

New Jersey, Mahwah 07430

85 McKee Drive;
tel. (201) 529-3800, Toll-free (800) 631-7172

Venezuela: Industrias Venezolanas Philips S.A.,
Av. Ppal de los Ruices,
Apartado Aereo 1167, Caracas 107;
tel. (2) 393811/353533

Zaire: S.A.M.E./S.Z.A.R.L., B.P. 16636, Kinshasa;
tel. 31693

Zambia: Philips Electrical Zambia Ltd.,
Mweneshi Road, P.O.B. 31878, Lusaka;
tel. 218511

Zimbabwe: Philips Electrical (PVT) Ltd.,
62 Umtali Road, P.O. Box 994, Beverley/Harare;
tel. 47211

For information on change of address:

Philips Export B.V.,
Scientific and Industrial Equipment Division,
Test and Measuring Instruments, Building TQ III-4, P.O. Box 218,
5600 MD Eindhoven - The Netherlands

For countries not listed here:

Philips Export B.V., S&I Export,
Test and Measuring Instruments, Building TQIII-3, P.O. Box 218,
5600 MD Eindhoven - The Netherlands;
Tel. (40) 782285