

SPECIAL MID-WINTER NUMBER

RADIO AGE

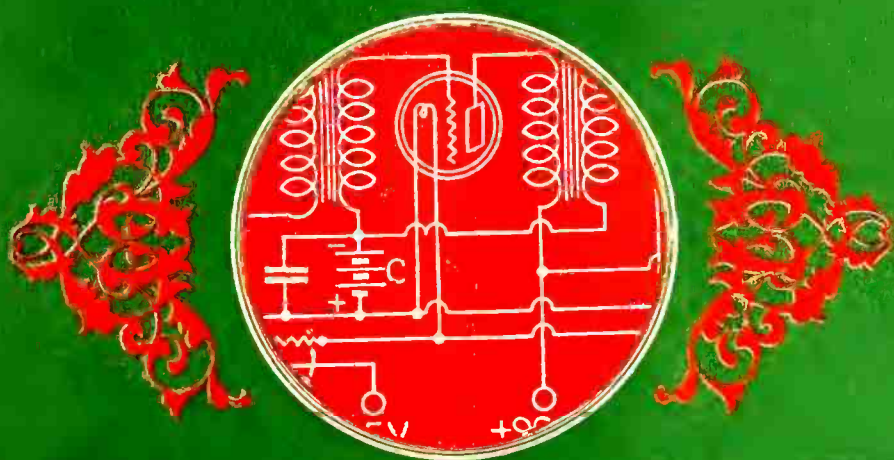

In This Issue

Robertson-Davis Hot Spot Fourteen
(With Blueprints)

Quadrode Superheterodyne Developments

More About the Screen Grid Tube

Highly Efficient Tuned R. F. Receiver

The New Infradyne Amplifier

*A Manual
for the
Set Builder*

Latest List
of
Broadcast Wave Lengths

25¢

30^{DAY} FREE TRIAL

Battery or All-Electric OPERATION

HERE is the great value offer of the day. Test and try this powerful seven-tube RANDOLPH RADIO for thirty days. After it brings in stations from coast to coast with amazing clearness—with easy one-dial tuning—after it easily equals any other radio regardless of cost—after you are more than satisfied then you can buy it direct at factory prices. Every RANDOLPH must make good before it is sold.

The RANDOLPH SEVEN-TUBE CONSOLE illustrated here can be had for use with batteries or connected direct to the electric light socket—absolutely batteryless—no batteries, chargers or acids—just plug in and tune in. 100% efficient either way. Its construction and performance have been tested and approved by leading radio engineers and authorities—by leading radio publications and laboratories.

7 Tubes—Single Control Illuminated Drum

One drum dial operated by one simple vernier control tunes in all stations with easy selectivity to tremendous volume. No overlapping of stations. Illuminated drum permits operation in the dark. Volume control for finer volume modulation. This is a seven-tube tuned radio frequency receiver with power transformers and power amplification. Space wound solenoid coils. Full and completely shielded. A real receiver of the highest quality. Tremendous distance, wonderful tone quality, simple to operate.

Beautiful Walnut Console Built-in Cone Speaker

The Randolph Seven-tube Amphiphonic Console illustrated above is housed in a genuine burl-walnut cabinet with two-tone hand rubbed finish giving it unsurpassed beauty. The same expert cabinet work has gone into the making of these consoles as in the finest furniture. Has built-in cone loud speaker that compares with any on the market. Accurately reproduces complete range of musical notes from the highest to the lowest pitch.

What Users Say

I have logged more than 50 stations from coast to coast.—Lloyd Davenport, Littlefield, Texas. I have logged 52 stations from Cuba to Seattle, the set is a world beater.—J. Tampionson, Detroit, Mich. Your set is a revelation, has all others tied to the post for distance and selectivity.—Waldo Powers, Vergennes, Vermont. On strength of its performance sold two more sets this week.—T. Scanlow, Orlando, Florida.

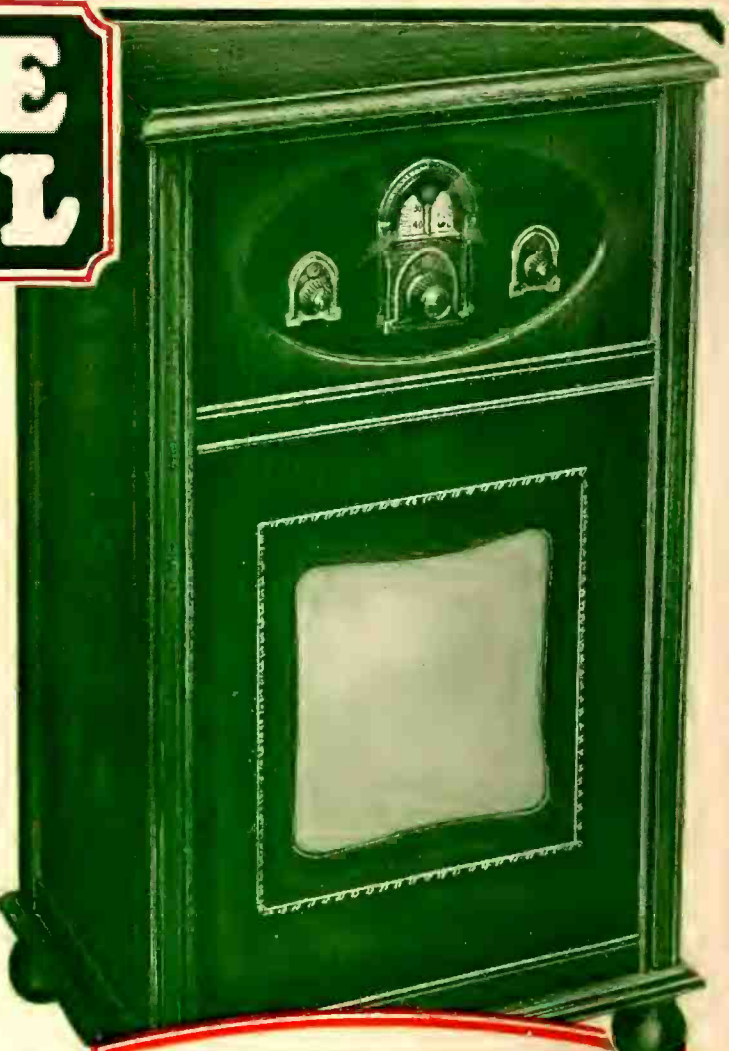

The Senior Six

Now you can have a new, modern, single-control, six-tube radio. Do not compare this set with old style 2-dial 6-tube sets selling for about the same price. The Randolph 1928 Senior Six has also been tested and approved by the leading radio engineers. Comes in a beautiful solid walnut cabinet of hand-rubbed finish. Single control. Illuminated Drum with space for logging. Absolutely dependable and very selective. Sent for 30 Days' Free Trial. You test it before you buy.

6-Tube
\$55
Retail Price
Single Control

MAIL COUPON NOW!

The Randolph Radio Corporation are pioneers in the manufacture of radios. All of its vast and unlimited resources have been used in making and perfecting of the Randolph Receivers. Because of our long and successful experience in the radio business, we are perfectly confident in sending out a Randolph Radio on trial. We know what it will do. Mail us the coupon now for the greatest radio offer ever made.

The **Randolph** \$ **99**
7-Tube Console
Single Control
RETAIL PRICE
Completely Assembled

Sensationally Big Discounts to Agents

Work either full or part time and make big money. Tremendous advertising campaign helps you sell. Regardless of whether you have ever sold before, be sure to get our proposition. The Randolph sells on first demonstration. Men and women both can make money this easy way. Get your demonstration set for thirty day's FREE TRIAL.

Use This Coupon NOW!

Randolph Radio Corporation,
711 West Lake Street, Dept. 306
Chicago, Illinois.

Send me full particulars about the RANDOLPH Six and Seven-Tube All-Electric and Battery Table and Console Sets with details of your 30 Day FREE Trial Offer.

Name.....

Address.....

City..... State.....

Mark here if interested in Agent's proposition.

RANDOLPH RADIO CORPORATION
711 West Lake Street Dept. 306, Chicago, Illinois

FREE!



Big Receiving Outfit Included in Course

Instruments shown here and others—sent to our students free of extra cost.

Clip coupon now—find out all about this big unequalled offer while you still have time to take advantage of it. Our training is intensely practical—these instruments help you learn to do the practical work. Receiving sets, from simplest kind to thousand-mile receiver. Many other big features.



J. E. SMITH
President

My Radio Training Is the Famous "Course That Pays for Itself"

Spare time earnings are easy in Radio when you know it the way we teach you. Increase your income almost from the start of your course thru practical knowledge we give you. We show you how to hold the job, then our Employment Department helps you get one. Free book "Rich Rewards in Radio" tells how.

Howard B. Luce of Friedens, Pa., made \$320 in 7 weeks during his spare time. D. H. Sullit of Newport, Ark., writes, "While taking the course I earned in spare time work approximately \$900." Earl Wright of Omaha, reports making \$400 in a short time while taking his course—working at Radio in his spare time only! Sylvester Senzo, 207 Elm Street, Kaukauna, Wis., made \$500.

And when your training is completed you're ready to step into a real big Radio job like C. C. Gielow, Chief Operator of the Great Lakes Radio Telegraph Company; E. W. Novy, Chief Operator of Station WERNY; Edward Stanke, Chief Operator of Station WGR; and hundreds of other N. B. I. Trained men. The National Radio Institute, originators of Radio Home-Study Training, established 1914, today offers you the same opportunities these men had, under a contract that pledges you full satisfaction or money refunded on completing our training. It's your big chance to get into Radio—mail coupon for FREE Book and proof.

"MEN! Here's the 'dope' you've been looking for-

HOW TO GET INTO THE RADIO BUSINESS"

J.E.S.

EARN BIG MONEY in Work That is Almost Romance

If you're earning a penny less than \$50 a week, clip coupon now for FREE BOOK! New Book, 64 pages, profusely illustrated, tells all about the Radio profession, thousands of opportunities—in work that is almost romance! YOU can learn quickly and easily at home, through our tested, improved methods, to take advantage of these great opportunities! Why go along at \$25 or \$35 or \$45 a week, when you can pleasantly and in comparatively short time learn to be a Radio Expert, capable of holding the big pay jobs?

Clip Coupon for Free Book

Don't envy the other fellow who's pulling down the big cash! Our proven home-study training methods make it possible for you, too, to get ready for a better job, to earn enough money so you can enjoy the good things of life. One of the most valuable books ever written on Radio tells how—interesting facts about this great field, and how we can prepare you, quickly and easily in your spare time at home, to step into a big-pay Radio job. You can do what others have done through our training. GET THIS NEW FREE BOOK. SEND COUPON TODAY.

J. E. SMITH, President

NATIONAL RADIO INSTITUTE

Dept. 2N

WASHINGTON, D. C.

Coupon Brings Free Book Mail It NOW!

Radio Needs Trained Men

National Radio Institute
Dept. 2N

Washington, D. C.

Dear Mr. Smith:
Without obligating me in any way, send me your FREE BOOK, "Rich Rewards in Radio," and all information about your practical, home-study, Radio Course.

Name

Address

Town State.....

SEND THIS COUPON TODAY

Please Mention Radio Age When Writing to Advertisers.

RADIO AGE

Established March, 1922

Volume 7 December-January, 1927-28 Number 4

CONTENTS FOR THIS ISSUE

	Page
Developments in the Quadrode Super-heterodyne..... By Frank Freimann	5
More About the World's Record Super 10.....	8
A Highly Efficient Tuned R. F. Receiver.....	12
The Robertson-Davis Hot Spot Fourteen.....	16
Hot Spot Fourteen Blueprints.....	18-19
A Constant Voltage B Eliminator.....	21
The Screen-Grid Tube and How to Use It.....	23
The Infradyne with New Amplifier.....	28
Latest Correct List of Broadcasting Stations, with Call Letters, Kilocycles, Meters and Power.....	38

Radio Age is published monthly by RADIO AGE Inc.
Publication Office, Mount Morris, Ill.

404 North Wesley Ave.
Address all communications to RADIO AGE, Inc.
Executive, Editorial and Advertising Offices
500 N. Dearborn Street, Chicago, Ill.

M. B. SMITH, *Business Manager*
FREDERICK A. SMITH, *Editor*

Advertising Manager
HARRY A. ACKERBURG
500 N. Dearborn St., Chicago, Ill.

Eastern Representative
HEVEY & DURKEE, 15 West 44th St., New York, N. Y.

Pacific Coast Representative
CONGER & MOODY, Sharon Bldg., San Francisco, Calif.
CONGER & MOODY, Higgins Bldg., Los Angeles, Calif.

Final Advertising forms close on the 20th of the 2nd month
preceding date of issue

Vol. 7, No. 4. Issued monthly. Subscription price \$2.50 a year.
December-January, 1927-28. Entered as second-class matter at post
office at Mount Morris, Illinois, under the Act of March 3, 1879.

Copyright, 1927, by RADIO AGE, Inc.

Chats

IT is now proposed by the Federal Radio Commission to eliminate three hundred additional broadcast stations from the present list. This will bring the total down to less than four hundred stations. This news will bring joy to a group of broadcast station owners who may have reason to believe that they will not be among those cut off. As the number of stations is reduced the value of the remaining stations is increased proportionately. The station which has a considerable investment in equipment and in a progressive campaign of good will will be reluctant to give up its tangible and intangible property without a protest.

The commission has cut out a difficult job for itself. The federal radio law has not been submitted to any recent acid test by any of the more influential station owners and it is likely that the wholesale reduction in the number of stations will precipitate such a test. E. F. McDonald, Jr., of the Zenith Radio Corporation gave the Washington authorities a shock when he chose his own wave length for WJAZ and then went to court and whipped the government when they objected that the station was "pirating." That led to legislation, which helped to clear the air and for such service Mr. McDonald received both blame and praise.

Far be it from this editorial sanctum to say what the radio commission should do or should leave undone. It is perhaps permissible, however, to hope that the federal bureau will leave the broadcasting stations alone insofar as is consistent with public convenience and private interest. We have no doubt that the commission is tormented with pressure from political and other influences who desire special privileges but we assume that the commissioners are as aware as the rest of us of the fact that yielding in any measure whatever to such influence would grievously injure public confidence in this commission, or in any commission.

Frederick Smith

Editor of RADIO AGE.

Silent Magic



Here is the Eveready Layerbilt "B" Battery No. 486, Eveready's longest-lasting provider of Battery Power.



TURN your radio dial, and presto! you turn your home into a theater, a concert hall, a lecture room, a cabaret, a church, or whatever you will. Turn the dial and your attentive ear does the rest. That is all there is to this magic of radio.

Or almost all. If a radio set is to work at its very best, attracting no attention to itself, creating for you the illusion that can be so convincing, you must pay a little attention to the kind of power you give it. There is but one direction, a simple one—use Battery Power. Only such power is steady, uniform, silent. It is called by scientists pure Direct Current. Any other kind of current in your

radio set may put a hum into the purest note of a flute, a scratch into the song of the greatest singer, a rattle into the voice of any orator.

Don't tamper with tone. Beware of interfering with illusion. Power that reveals its presence by its noise is like a magician's assistant who gives the trick away. Use batteries—use the Eveready Layerbilt "B" Battery No. 486, the remarkable battery whose exclusive, patented construction makes it last longest. It offers you the gift of convenience, a

Radio is better with *Battery* Power

gift that you will appreciate almost as much as you will cherish the perfection of reception that only Battery Power makes possible.

NATIONAL CARBON CO., INC.
New York  San Francisco
Unit of Union Carbide and Carbon Corporation

Tuesday night is Eveready Hour Night—9 P. M., Eastern Standard Time

- | | |
|------------------|--------------------|
| WEAF—New York | WOC—Davenport |
| WJAR—Providence | KSD—St. Louis |
| WEEL—Boston | WCCO—(Minneapolis) |
| WFI—Philadelphia | —(St. Paul) |
| WGR—Buffalo | WDAF—Kansas City |
| WCAE—Pittsburgh | WRC—Washington |
| WSAI—Cincinnati | WGY—Schenectady |
| WTAM—Cleveland | WHAS—Louisville |
| WWJ—Detroit | WSB—Atlanta |
| WGN—Chicago | WSM—Nashville |

WMC—Memphis

Pacific Coast Stations—
9 P. M., Pacific Standard Time

- | |
|-----------------------|
| KPO—KGO—San Francisco |
| KFOA—KOMO—Seattle |
| KFI—Los Angeles |
| KGW—Portland |

EVEREADY
Radio Batteries
—they last longer

The air is full of things you shouldn't miss

Build Your Own Power Amplifier



Transform your Receiver into a Real Musical Instrument!

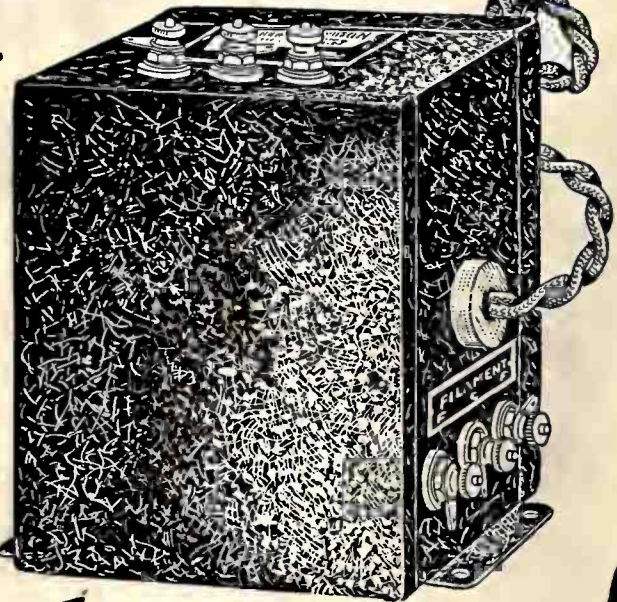

With a screw driver, a pair of pliers, and a soldering iron you can build a Thordarson Power Amplifier and B-supply in your own home that will equal the finest commercial amplifier on the market. Complete construction booklet and simple diagram accompany every transformer.

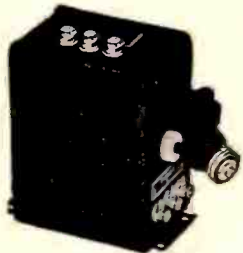

R-210 Power Compact . \$20

Thordarson R-210 Power Compact

The Thordarson R-210 Power Compact is scientifically designed to give maximum electrical efficiency and to make home assembly of power amplifiers as simple as possible. The R-210 Power Compact is the foundation unit and contains the following apparatus: (1) A power supply transformer designed for UX-216-B rectifier; (2) Two filter chokes of 30 henries inductance and 65 M. A. current carrying capacity; (3) A 7½ volt supply center tapped for the filament of one UX-210 power tube. Wiring of the complete amplifier is simple—20 leads complete the assembly.

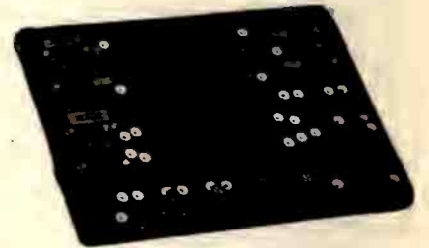

R-211 Metal Baseboard, including sockets, binding posts, mounting screws, and hook-up wire \$5

New Metal Baseboard for R-210 Compact Amplifier

To further simplify home construction of the R-210 type amplifier, you can now buy this new crackled finished metal baseboard. All spring sockets and binding posts are mounted and included in the list price. All mounting holes are drilled. All holes for sub-panel wiring are carefully insulated. Location of all sub-panel wiring is marked under baseboard.

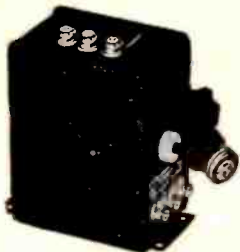

R-171 Power Compact . \$15

R-171 Power Compact

This power compact is similar to the R-210 type, but is adapted for home construction of power amplifiers using the Raytheon BH rectifier and UX-171 power tube. Designed to meet the popular demand for a low priced yet highly efficient power amplifier. Delivers 320 volts either side of center to the Raytheon BH rectifier. The two choke coils are rated at 85 M. A. 30 henries. The filament winding of 5 volts center tapped is suited to one UX-171 power tube. Two 0.1 Buffer Condensers are also included in the case. Wiring the complete amplifier and B-supply is merely a matter of connecting 18 leads.



No. 2098 Power Supply Transformer . . . \$20

T-2098 Power Supply Transformer—T-2099 Double Choke Unit

Here is an extra heavy duty power amplifier supply that will satisfy the most exacting demands for excess power. An amplifier using this transformer and choke unit will deliver 425 volts at 130 M. A. drain, sufficient for the heaviest receiver using two UX-210 tubes in power push-pull. Transformer T-2098 delivers 550 volts each side of center tap and is designed to supply two UX-216-B rectifiers (full wave). The 7½ volt filament supply will easily handle two UX-210 power tubes. The double choke unit T-2099 consists of two 30 henries 130 M. A. choke coils mounted in a compound-filled case.



No. 2099 Double Choke Unit \$14

← Get this **FREE Book!**

THORDARSON POWER COMPACT

THORDARSON ELECTRIC MANUFACTURING CO.
Transformer Specialists Since 1895
WORLD'S OLDEST AND LARGEST EXCLUSIVE TRANSFORMER MAKERS
Huron and Kingsbury Streets — Chicago, Ill. U.S.A.

THORDARSON ELECTRIC MFG. CO.
 500 West Huron St., Chicago, Ill.

Gentlemen:

Please send me a copy of your free booklet "Power Amplification Simplified."

Name

Address

City..... State.....

(3571)

The Quadrode Super-Heterodyne

A Super-heterodyne in the simplest form, with *new* features and *new* merits, that make it an outstanding performer among super receivers

Builders everywhere were deeply interested in the description of this circuit in the November issue of Radio Age.



By FRANK FREIMANN

EVERY month brings a "new" circuit of some "dyne" or other into creation, so new in fact, and so wonderful, that, according to its creator, it will send everything else into oblivion. The public has been so overfed within the last few years on circuits that petered out on test that they have finally ceased to bite. There have in reality been very few new circuits invented or created, although there have been great strides made towards better radio in the development of better apparatus. Comparison of our present tubes, audio transformers, loudspeakers, and other devices with those of the past years will confirm that. Is it a wonder then that we should hesitate in proclaiming a new super-heterodyne? We did so last month in the November issue, and the interest displayed by readers who built the set gives us no cause for regrets. The super-heterodyne described is new, not for novelty's sake, but because there is actual merit in its newness.—The Editor.

THE Quadrode super-heterodyne—so named because a quadrode or four element vacuum tube is used in the mixer circuit—made good all that has been claimed for it. In a two weeks test for consistent reception at least two West Coast stations were brought in nightly, and on fair nights as many as a half dozen stations west of the Rockies were heard. Broadcasts from the states of Washington, Oregon, and California came in with sufficient volume to entertain a room full of people. A small Bodine loop or the house lighting system was used to pick up the energy, an outside wire was never used at all. One enthusiastic fan wrote a letter containing a log of some 52 stations outside of Chicago and the surrounding stations area, which were received in a two nights' vigil, through the maze of locals. These and other verifications are a sure proof of the pudding.

Nothing about the set or circuit is radically different from the usual super-heterodyne receiver. The present change is, however, obviously an advantage over the usual super-heterodyne. The highest grade of material was chosen for the make-up of the set, and this, together with the su-



The Quadrode Super-Heterodyne installed in Ehlert cabinet. The Temple speaker is enclosed. Note the substantial elegance of the complete installation.

perior design, make it a better super-heterodyne. Very likely, the principal feature that has put this set into good graces with radio set builders, is the minimum of effort required to build and operate it, with the minimum strain on the money pouch, and the maximum efficiency that is derived from it.

The departure from the customary super-heterodyne, as has already been pointed out in the article which appeared in the November issue of RADIO AGE, lies in the mixer circuit. Why run the loop or grid lead all over the set to pick up energy from the oscillator tube and mix it in the

detector tube to obtain a beat frequency, when this can be accomplished in one tube with less wiring? That is what we wanted to know.

The first progressive step was taken by some designers by using direct coupling from the plate circuit of the oscillator tube to the detector tube plate circuit. But why the extra tube?—we still ask.

Attempts were made a few years ago to popularize a circuit in which one regular three element tube was used for a mixer. Careful balancing of condensers and other tedious adjustments were necessary, and then what was the result? The circuit

met its fate early so what does it matter after all? A well known concern for several years used a somewhat similar system to make a single tube do the work of creating a beat frequency from the combined station frequency and the frequency generated by the tube itself. The oscillator circuit was operated at half the frequency required to bring about the required beat note for intermediate frequency amplification, and the first harmonic (double the frequency of the oscillator) was combined with received frequency. This was to avoid inter-action between the two tuned circuits, that is the loop tuning circuit and the oscillator tuning circuit, which when operated at the regular wave lengths interfered with one another because of the slight frequency difference. The disadvantages of this system are so well known that it is needless to enumerate them. It also is a "has been."

With two grids in the same tube the two circuits (input from loop or coil, and oscillator) are so isolated that no interference can take place. The only coupling is that through the interelectrode capacity which is negligible. Still there is the common plate circuit; by this virtue the two frequencies are mixed within the tube itself, without the aid of external pick up coils and wiring. The ultimate attainment is a mixer system which is as effective as it is simple.

Another contribution well worth mentioning is the regenerative amplification gain in the detector circuit. Since the plate coil of the oscillator coupler and the primary of the first intermediate amplifier in the S-M 440 are common to both circuits there is enough reactance present to cause feed-back through the interelectrode capacity within the tube. Consequently the detector circuit will also oscillate, this, however, is prevented by placing the .0002 mfd. by-pass condenser across the primary coil in the S-M 440 amplifier. But the capacity of the by-pass condenser is large enough only to prevent actual oscillation, there will be still enough reactance in the plate circuit to permit some regeneration.

We must say something about the tone quality; this is no longer to be neglected, in fact, it is the chief requisite today. Well, everyone who has heard the Quadrode super-heterodyne said it had it. An 18-inch Temple speaker was used for the reproduction of music and even the most critical of connoisseurs made flattering remarks about the excellent reception. A 171 type power tube is highly recommended for the last stage, for the amplification on even distant stations is so great, that with the tendency to bring them in loud because they are remote, bad distortion when an ordinary tube is employed will result.

To make the instructions simple enough for anyone to build a pictorial diagram is shown. This is identical with the diagram in the blue print section last month, except that a filament switch is included, and also the right side terminal of the 200 ohm potentiometer is connected directly to the negative A battery instead of the filament terminal, for reasons explained later. The parts should be mounted in the manner described in the initial article and not in the relation shown in this dia-

gram, which is only to simplify the wiring for those not familiar with symbols.

The negative lead to the 200 ohm potentiometer is taken directly from battery end of the amperites instead of the filament terminal so that a slight negative potential can be applied to the grids of the intermediate amplifier tubes. This is not essential for with good tubes the amplifier can be brought to the point of oscillation even with the connection as originally recommended, however, when tubes are used that are not so "hot" it is advantageous to use this connection, also lower plate voltage than 90 volts can then be used. Be sure that the stators of the condensers are connected to the grid term-

it should be checked and re-checked several times. One can never be too sure, and nothing can be lost by being careful. With all the voltages applied to the tubes, one tube should be inserted in each socket (except the five prong socket). In the event that the filament wiring is mixed with the plate voltage only one tube will be lost instead of the whole six.

With the set functioning properly, the two dials should be rotated simultaneously, starting at the highest numbers on the dials. For local stations the left hand potentiometer should be turned somewhere towards the left to decrease the amplification in the 440 amplifier, and then adjust the right hand potentiometer to any desired volume. When an out-side antenna is used the wavelength dial should be tuned off the signal, as the energy on local stations will be so large that the detector tube will be overloaded. This tube can be overloaded so badly as to stop the oscillations in the oscillator circuit.

In hunting for dx stations the left hand potentiometer knob should be completely to the right, or just above the point where oscillation in the intermediate frequency amplifier starts. This puts the amplifier into the most sensitive position. Now turn both dials just far enough to tune out the local station. Then sweep the wavelength dial from right to left over about ten points; there will be one place where the dials are in resonance.

A slight hissing sound will be heard at this point, or if a station happens to be on that channel it will be heard. The point where the dials are in resonance should be when the numbers on each dial correspond. If the dials are more than a few points off they can be lined up as explained before. The fact that the dials run so close together over the whole wavelength band makes it very easy to pick out distant stations, for only when the dials are in resonance (that is the oscillator and input circuit to the intermediate circuit) is it possible to get distant stations on any set.

It is a simple matter to "Powerize" the Quadrode Super so that it may be operated from the house lighting circuit. The current drain is about fifty milliamperes for the B current supply, and most good B eliminators will handle this power without overloading. On some eliminators a slight hum may be experienced when the 200 ohm potentiometer is turned to the position where the intermediate amplifier will be in the most sensitive state. This can be eliminated by placing a two microfarad by-pass condenser across the 90 volt and negative terminal, and one across the 45 volt and negative terminal, of the eliminator. Only one condenser may be needed to remove the hum (if it should be there), depending upon the eliminator used.

With a power tube in the second stage of audio amplification the filament current required is two and one-quarter amperes. Some "A" eliminators with a two ampere capacity will work satisfactorily, but it is more reliable to have one with a two and one-half or three ampere capacity. Elsewhere in this issue is described a B battery eliminator which was designed largely for the Quadrode Super-heterodyne. With

(Continued on page 36)

Parts for Quadrode Super-Heterodyne

- 1—Aero Antenna coupler No. U-96
 - 1—Aero Universal Oscillator coil U100
 - 2—Camfield .0005 S. L. F. condensers
 - 2—Kurz-Kasch vernier dials
 - 1—S-M 440 amplifier
 - 2—S-M 240 audio transformers
 - 2—S-M 511 sockets
 - 1—S-M 512 socket
 - 1—S-M 540 bracket (pair)
 - 1—Frost 200,000 ohm potentiometer
 - 1—Frost 200 ohm potentiometer
 - 1—Yaxley cable plug and connector
 - 1—Yaxley on-off switch
 - 4—X-L binding posts (antenna, ground and two loops)
 - 1—5A Amperite
 - 1—3A Amperite
 - 1—Carter .00025 condenser with clips
 - 1—Carter .0002 fixed condenser
 - 1—2 meg. Polymet leak
 - 2—Carter .5 mfd condenser
 - 1—10 x 20 x 3/16" sub panel
 - 1—7 x 21 x 3/16" front panel
 - 1—Sangamo .001 condenser
- Accessories**
- 1—Voltron 171 Tube
 - 1—Voltron double grid tube
 - 5—Voltron 201A tubes
 - 1—Loop aerial (Bodine)
 - 1—Wire or aerial—(Luxem and Davis)
 - 1—S-M or Thordarson B Power unit
 - 1—Ehlert Table Cabinet or Ehlert Speaker Console
 - 1—Temple Speaker
 - 1—"A" power unit

inals of the tube socket and the rotors to the filament terminals.

If the variations between dial readings should be greater than three or four points, one dial can be slightly off set so that they will be together.

Some general suggestions on the operation of the set will prove useful, to those particularly who have had little experience in the tuning of super-heterodyne receivers.

After the wiring of the set is completed

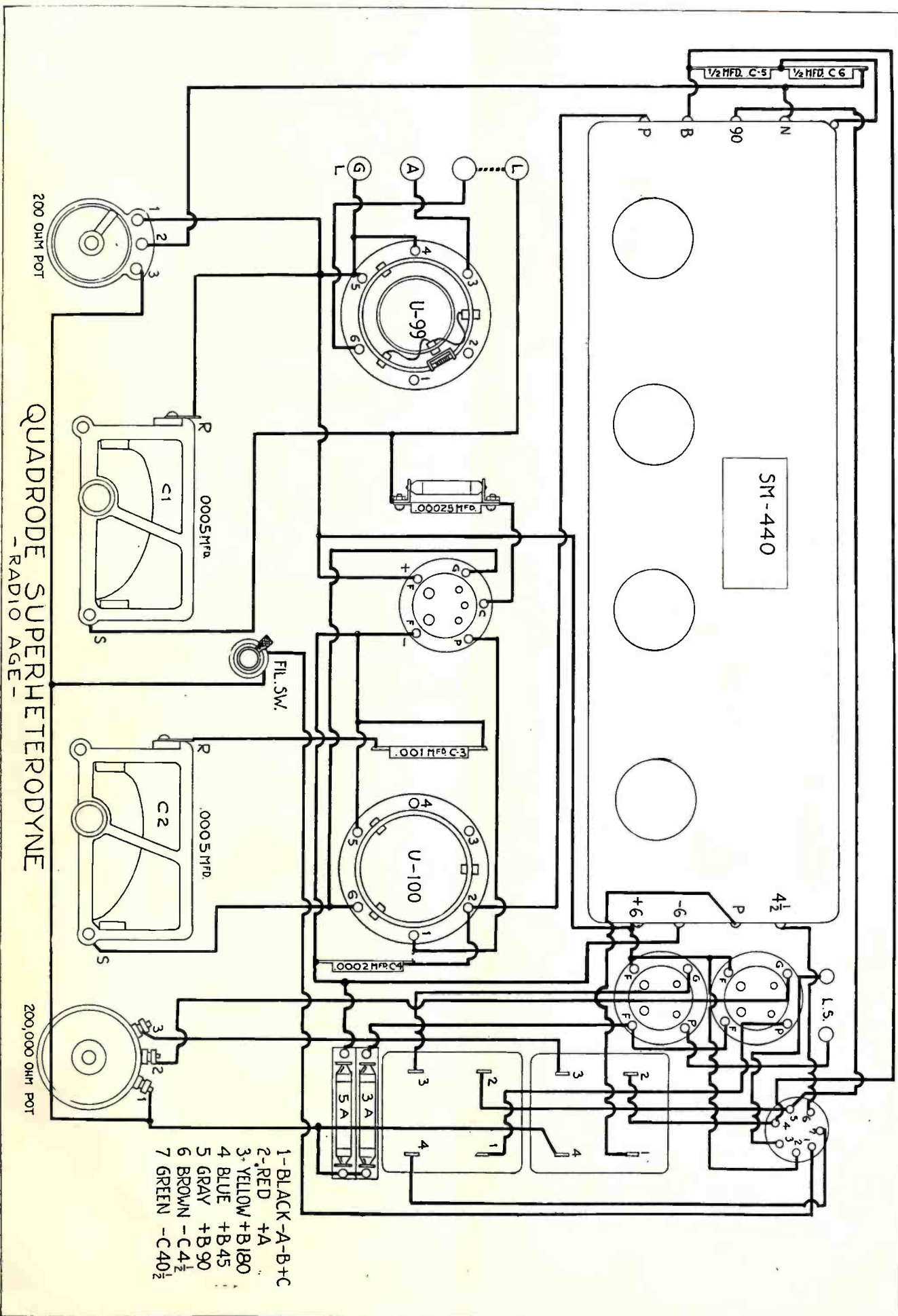

More About World's Record Super 10



The World's Record Super 10 Installed in Cabinet

By ALEXANDER MAXWELL

THE Scott World's Record Super 10 has had remarkable success since its introduction on the market early this season.

The basic reason for its phenomenal popularity lies in the surprisingly dependable operation and uniform performance. We all have dissimilar ideas as to what perfect radio performance should include. To some tone is paramount. The midnight dial twister wants nothing but DX. The dweller in the metropolitan area will consider nothing but extreme selectivity. The rural radio man wants a receiver that will be sensitive. The non-technical man wants simplicity. The man with limited means wants low cost and a set that will not be obsolete before his bank book has ceased to groan. Those with mechanical bent want to build their own but demand a reasonable assurance it will function when completed. Ease of maintenance is insisted on by all, and the latest problem to confront the designer is a set which will function directly from the light socket.

The name Scott World's Record Super 10 covers a lot of ground. So does the set. The "10" merely indicates the number of tubes that are used. They are used in a circuit that has as its chief purpose the interception and faithful amplification of local and long distance radio signals. Just how successfully this is accomplished may be fully appreciated only by hearing the receiver.

Four, undisputed, unchallenged long distance broadcast reception records, duly attested and verified, entitle the receiver to be called the "World's Record Super." The brief story here related explains why this receiver carries this inspiring name and further justifies all claims made for the same. It is an interesting and colorful tale of radio adventures.

One of Mr. Scott's contributions to the art of radio is the method of manufacturing, testing and matching radio transformers. His outstanding achievement, however, is the establishment of four world's records for long distance

reception which was accomplished some time ago but still stands unequalled and unchallenged.

These four long distance records were made with an early model of his famous receiver. This nucleus bore no special name and consisted of nine small peanut tubes and suitable equipment, considered at that time the best that could possibly be obtained. After innumerable tests, Mr. Scott felt that the receiver was ready for a rigorous sensitivity test, and forthwith journeyed to New Zealand, where he conducted listening tests with this receiver.

The results of these tests are radio history. Consistent reception was accomplished over the span of more than six thousand miles, and no less than four world's records were established, aside

from the many other astounding feats of performance of the test receiver. The log of reception covers seventy closely written pages. Space does not permit the publishing of the account in these pages at the present time.

The consistent reception at New Zealand of stations 6,000 miles or more distant is ample evidence of the sensitivity of a radio set. From the information gleaned by this performance the World's Record Super 10 was developed. From an engineering viewpoint the present model is vastly superior to the original test model, chiefly because radio has progressed and better and more accurate parts are now obtainable on the open market. The basic circuit and essential parts have not been changed, the

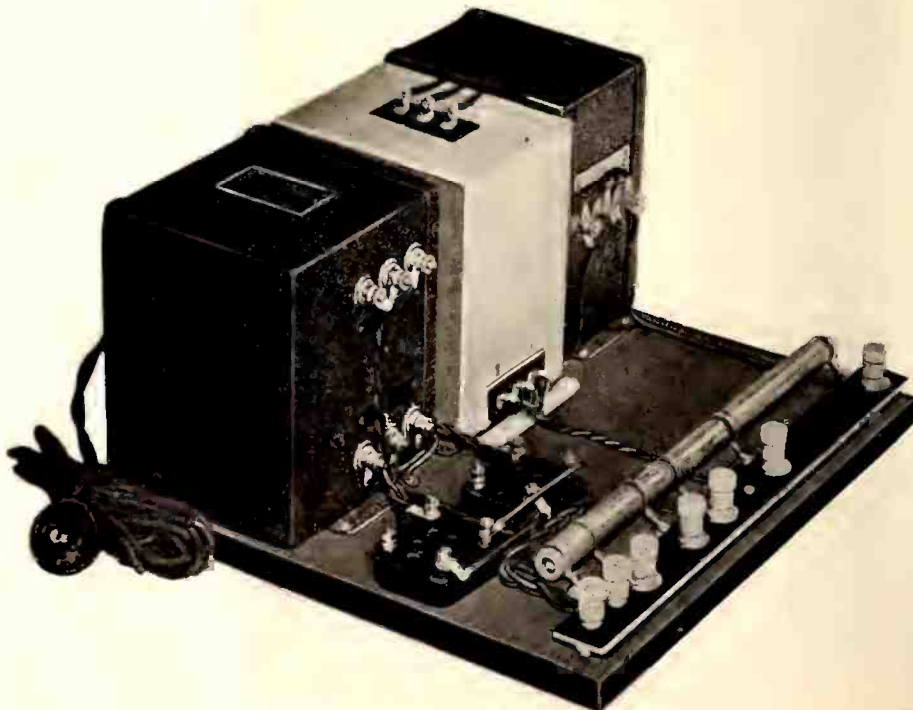

The B Eliminator for the World's Record Super 10

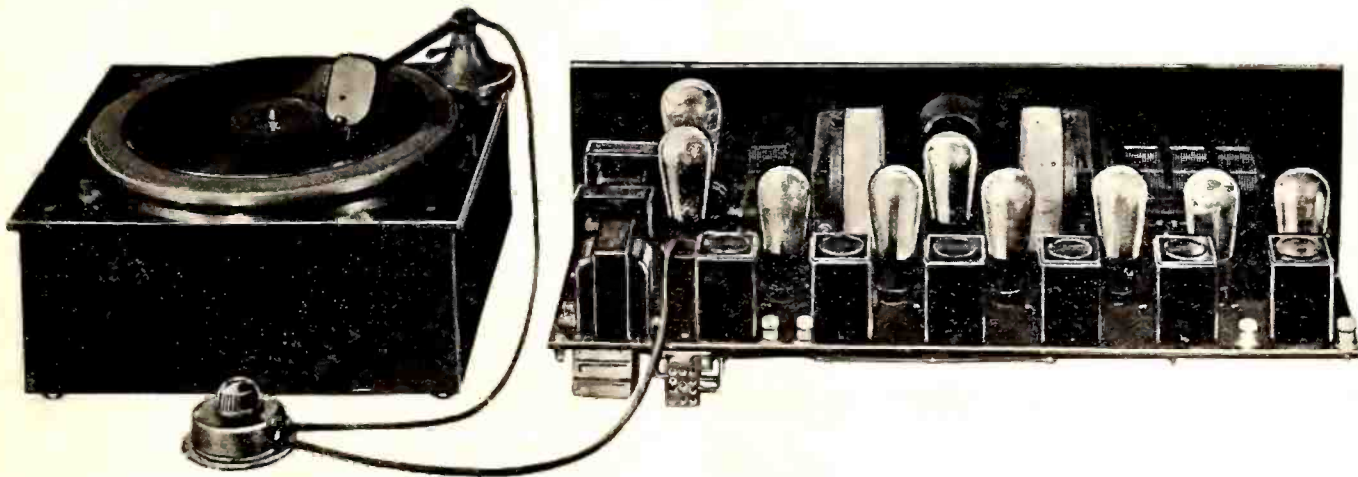

Method of attaching the World's Record Super 10 receiver to the phonograph to get richer, sweeter music out of the whirling record

only difference in the finished product being the minor refinements which only years of constant experimenting can bring about.

You can appreciate this receiver only by hearing it in actual operation, bringing in local and long distance stations with an ease that makes one gasp. Not only are distant stations brought in right through the high-powered local stations (the laboratory is located in the shadow of some of the strongest of Chicago broadcasters), but the volume and clarity is superior.

"How is such natural tone possible?" is a question commonly asked the user of a World's Record Super. The superior quality of tone is obtained by careful and painstaking observance of certain engineering principles which most receivers fail to stress. A correctly designed audio system, carefully biased, by-passed and energised is employed. The largest receiving power tube now on the open market is used in the last audio stage to handle the tremendous output. There is consequently no distortion of any kind in the received music or program, even when the receiver is functioning on a high powered local. A 112A tube in the first audio stage further insures that there are no irregularities in the amplification of the received signals.

The audio amplifier is only at its best when used in conjunction with the preceding circuits of the World's Record Super 10, all of which are designed for tone quality as a prime requisite. The result is music, sweet and true.

Of course it is understood a good, well designed reproducer must be used. Silvery music never issues from a tin horn. Money invested in a reliable loud speaker is well spent.

Owners of the World's Record Super 10 in Chicago tune in WJZ with ease when the closely adjacent WMAQ is on the air, without an iota of interference practically every night. This is a 10 kilocycle separation, the keenest tuning that any receiver may accomplish without sacrificing tone quality. The volume is sufficient for dancing, and there is absolutely no background from WMAQ. Who can ask for a more drastic test than this?

Here in Chicago users have picked up

KFI in Los Angeles as often as three or four times a week, and held them as long as desired. KFI is just 10 kilocycles from WCFL, but the signals come through loud and clear with no interference or distortion.

Certain fans will remark about this time, "Why bother with distant reception when local programs are unbeatable?" One answer is, everyone is not fortunate enough to live where there are truly appreciable local entertainments, and another answer is the same as may be asked the owner of a car. Why pay good money for a car that will go a mile a minute when the law says thirty-five miles an hour is enough? The answer to both questions is that the user has the satisfaction of knowing that he can get a burst of speed when no cop is in sight, and the same may be said of the radio, for should even the most conservative user suddenly turn DX hound and crave the annihila-

tion of half the world, he has the weapon for accomplishing the feat at his hand! It is the satisfaction of knowing he can if he chooses, that makes the owner of a Scott World's Record Super 10 swell out his chest with pride.

There are a number of features peculiar to the World's Record Super 10. Enumerated briefly they are as follows:

1. The use of a very short antenna (30 to 50 feet).
2. The filtering action of two stages of tuned radio frequency amplification, increasing range, selectivity and making the set a "one" spot receiver.
3. The use of the beat frequency principle of reception which is the most selective and sensitive system of reception known to radio engineers today.
4. The use of three stages of intermediate frequency amplification of intelligent, efficient and practical design.

B ELIMINATOR FOR WORLDS RECORD SUPER 10

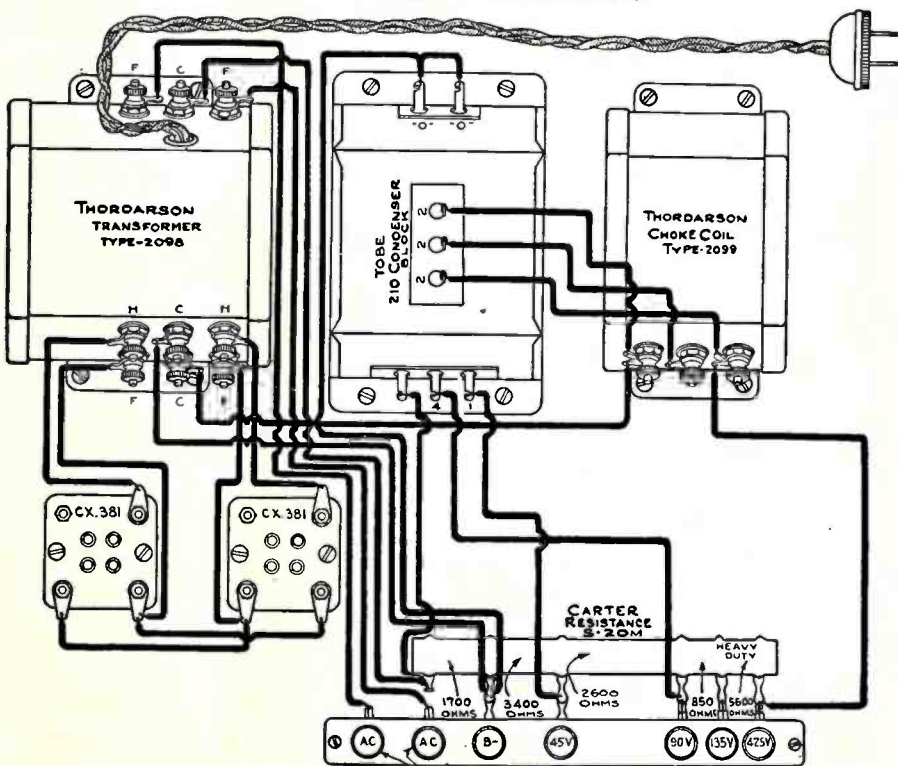

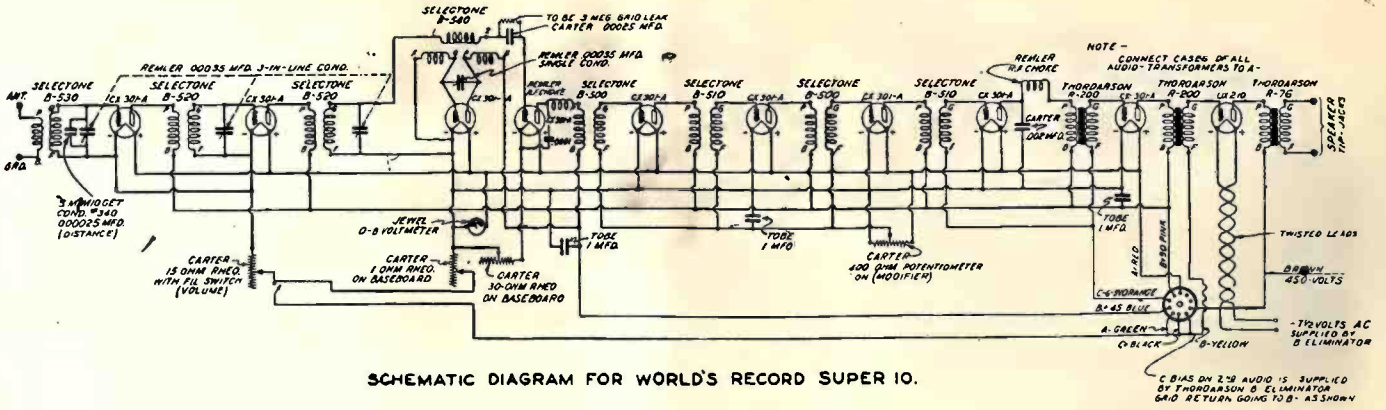

SCHEMATIC DIAGRAM FOR WORLD'S RECORD SUPER 10.

NOTE - FOR BEST RESULTS WITH THIS RECEIVER USE THORADARSON SPECIAL B ELIMINATOR

5. The general design of the transformers used in the receiver in conjunction with the choice of associated equipment which represents an aggregation of the finest devices in radio today.

There are any number of fine engineering points involved in each of the foregoing enumerations that could be discussed at great length.

The first impression of a radio set is the one obtained by the eye. If this is distasteful it takes a heap of efficient functioning to counteract it. From the foregoing description one is liable to arrive at the conclusion that a set which will perform in such a phenomenal manner must resemble a printing press in appearance, or at least a telephone switchboard. It will then be a pleasant surprise to see that there are only two tuning controls on the panel, with three small knobs which are used for vernier adjustment. Infinite pains have been expended to make this receiver as pleasing in appearance as it is simple to operate and efficient. Figure 1 shows the front view.

There is no guess work in the operation of a World's Record Super 10. After the preliminary adjustments have been made the set is given an operating test, then it is ready for continuous service. There is no guesswork, even the tuning is now calculated for you beforehand by ingeniously calibrated tuning strips which accompany each set of transformers. These

calibrated tuning strips are fitted on the Remler Drum Dials and tell exactly where they should be set for the reception of a particular wavelength. This is an exclusive World's Record Super 10 feature and is possible only because of the exceptional uniformity of the Selectone Transformers. Each set of transformers is matched, and each matched set is uniformly and precisely the same. This explains how tuning may be laid out beforehand, even before the transformers have been built into a receiver.

A receiver isn't considered modern unless it is connected to the light socket. There is more power available in the lighting mains than any reasonable number of batteries. The World's Record Super 10 is a powerful set and batteries are not adequate for the power delivery.

In this connection a special plate current supply has been designed, a unit expressly conceived for use with this receiver. With your kit of parts your dealer will supply you with a full sized working blue print showing the construction and assembly of this power supplying device. It has provisions for all the necessary voltages as required by this receiver, and in addition supplies C battery energy for the 310 power tube in the last stage audio amplifier.

This power supply is a simple affair to build, requiring about two hours of actual construction time. The instructions are

so clear it is practically impossible to make a mistake.

The World's Record Super 10 cannot be purchased completely assembled from a manufacturer. Your local radio store will more than likely have one on demonstration that is already assembled. This receiver is custom-built. You may build it yourself if you choose, or any of the better grade radio service men will do the wiring for you.

The release of full sized working blueprints showing the wiring and assembly, in conjunction with the issuance of printed instructions giving the order of the operations to be performed makes the job of building the World's Record Super 10 a simple pleasure.

When you install the World's Record Super 10, with its associated power equipment, you simultaneously provide yourself with another fine source of music, equivalent to the wonderful electric phonographs now in vogue. This feature is the adaptability of the World's Record Super 10 to phonograph pickup, and provides you with the electrical reproduction of phonograph music, equal to the most expensive combinations now being exhibited in music shops.

Phonograph pickup, simply explained, is the playing of phonograph and vitrola records through your radio loud speaker. The audio amplifier is used to intensify the electrical vibrations generated by an

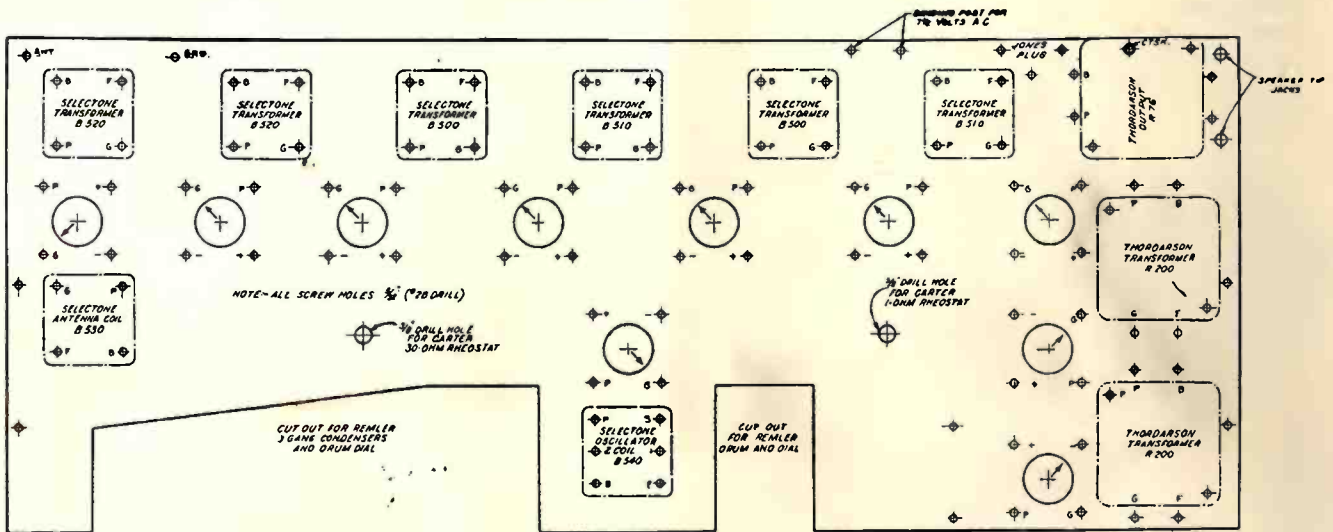

BASEBOARD LAYOUT FOR WORLD'S RECORD SUPER 10

CAUTION - WHEN TRANSFORMERS ARE PLACED CORRECTLY THE WORD SELECTONE WILL FACE PANEL.

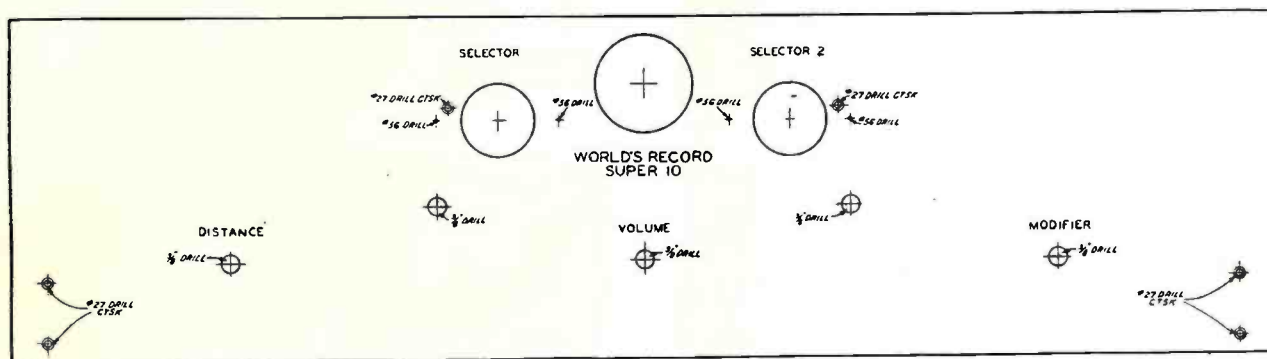

PANEL LAYOUT

ingenious device that is called a pickup. When installing the pickup arm it is only necessary to remove the second detector tube and insert the plug provided. Figure 2 shows how this is done. The pickup arm is either attached to the tone arm of the phonograph, if it is to be permanent, or set separately alongside the record table. The needle of the pickup unit is then placed on the record instead of the usual reproducer.

Radio for R. R. Trains

After many months of developmental work on the lines of the New York Central, the radio engineers of the General Electric Company, have designed an effective and reliable system of radio communication between the front and rear ends of trains, particularly of long freight trains.

The new system, and some of the problems encountered were explained recently by I. F. Byrnes, a radio engineer, at a meeting of the New York Railroad Club.

Preliminary investigation was carried on at Schenectady on engine and caboose. Several different types of antenna were investigated on the locomotive and it was found that the most effective type consisted of a wire running parallel to the boiler, and about fifteen inches from it. This was stretched between the stack and the rear end of the cab roof, as far as possible from the boiler and at the same time within the clearance limit of the right-of-way. The caboose antenna was placed four and a half feet above the roof, running parallel to the caboose. Antennas of the type used on engine and caboose do not possess any marked directional characteristic, but they are inefficient radiators, due to their low effective heights, and for this reason require more power for a given transmission range, than would be necessary if higher antennas were available.

Tests showed that the 2300 to 2750 kilocycle band offered the best transmission frequency. In order to provide a strong telephone signal at a distance of from one to two miles a power of 50 watts delivered to the antenna, was found necessary. While communication is possible on less power, there must be sufficient margin to care for unusual conditions.

A radio telephone system must incorporate an effective calling system if it is to have a maximum degree of utility. The

original work included the use of a bell actuated by a relay for calling purposes. This arrangement was later discarded because it was comparatively easy to secure false indications of calls. Excessive jars caused relay contacts and it was also possible for static and other disturbances to cause the bell to ring. The calling system finally developed utilized a loud speaker which produces a shrill note whenever a push button is depressed at the transmitting end. The pitch of this note is adjusted so that it is easily heard above the usual train noises. In addition the loudspeaker may be used in place of earphones for receiving conversation when the running noises are not too great.

Radio Saves Forests

The Department of Agriculture and other agencies concerned with the protection of Federal, State, and private forests from fire are keeping as watchful an eye on the weather these days as the navigators of ships at sea.

Increasing realization of the important rôle the weather plays in the forest fire hazard has led the Weather Bureau of the United States Department of Agriculture to establish a systematic forest fire-weather warning service in several sections of the country, and regular forecasts are being sent out to apprise foresters and forest owners of dangerous fire weather so that they may shut down logging operations and slash burning and mobilize fire-fighting units with the least possible delay.

In the Pacific Coast region, where some of the most valuable forests in the United States are situated, the fire-weather warning work has been under way for some time. Fire-weather forecasts are issued twice daily by the Weather Bureau and are disseminated by telegraph to important key points, by radio and by newspapers. The radio broadcasting of these forecasts is one of the most recent developments, and fire-weather bulletins now are being sent out from 16 Pacific Coast and Northwestern stations.

The worst fires in Washington and Oregon occur in connection with the dreaded east wind. When these winds are preceded by a period of warm, dry weather fires start easily.

After Factory Facts

For the first time in the history of the radio industry, official information regarding radio manufacturing is to be made available to the public and to the industry through cooperation of the United States Government and the Radio Manufacturers Association. The Federal Government, through the Department of Commerce, has accepted a plan proposed by the Radio Manufacturers Association to gather statistics from the nation's manufacturers of radio receiving sets, accessories and parts. Reliable and official statistical information as to the radio manufacturing industry will be issued quarterly.

With the assistance of the RMA, the manufacturing statistics will be gathered, compiled and published by the Electrical Equipment Division of the Bureau of Foreign and Domestic Commerce, Department of Commerce, of which Mr. Marshall T. Jones is chief. Comprising as it does more than 300 or virtually all of the leading manufacturers of radio of the country, the RMA is fortunately in a position to give the utmost service to the Government in securing manufacturing data hitherto unobtainable.

The Department of Commerce is now engaged in sending to manufacturers a questionnaire showing in detail their factory shipments for the last three months of 1927.

The information will be published by the Department of Commerce early in January. This and subsequent quarterly publications of manufacturing statistics will inform the public regarding the progress of the radio industry and be a valuable guide to manufacturers in determining their production. The information is to be given in strict confidence by the manufacturers to the Government with the expectation of wide cooperation by the manufacturers.

A Radio Christmas

More radio receiving sets will be installed in homes this Christmas than in any previous year. Interest in radio is constantly increasing and to the thousands of new owners of radio sets as well as the millions of devotees of broadcast entertainment, Powel Crosley, Jr., President of The Crosley Radio Corporation, will sponsor a special Christmas festival of music to be broadcast through the Red Chain of 25 stations, Christmas afternoon, December 25, from 5:30 to 6:30.

Highly Efficient R. F. Receiver

Loftin - White Constant
Coupling adapted for com-
mercial use in a simple,
effective, rugged circuit

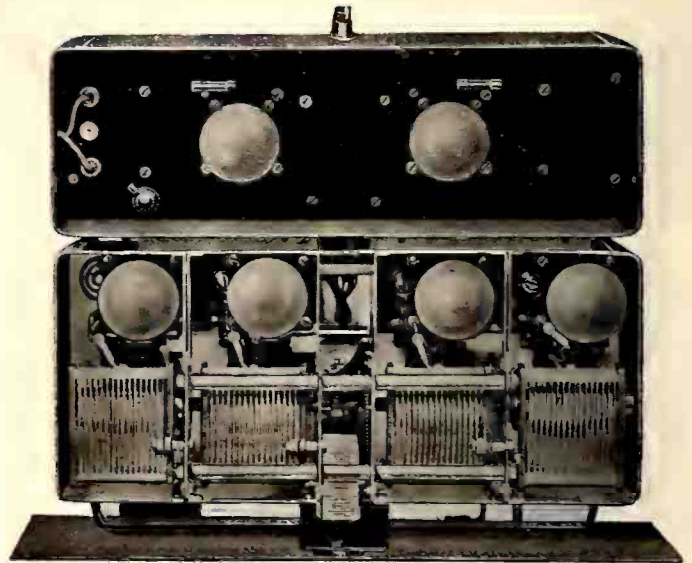

Fig. 1. Arborphone Model 25 Receiver

AS MANY of our readers know, the Loftin-White circuit was developed about a year ago by Edward H. Loftin, former Lieutenant-Commander, U. S. N., in charge of radio research and patent work, and S. Young White, a private experimenter of note in radio engineering circles. The circuit which bears their name was brought about as a result of their investigations aimed at overcoming the difficulties inherent in tuned radio frequency circuits.

Immediately after the appearance of the circuit there was a good deal of enthusiasm over it on the part of experimenters, but the circuit did not reach full popularity until recently. This article deals with a commercial adaptation of the perfected radio frequency circuit of unique character.

We are all familiar with the difficulties encountered in tuned r. f. receivers, these were explained quite fully in the November issue of RADIO AGE in the article entitled "Hints on the Performance of Tuned R. F. Sets." The greatest difficulty has been to design a set that would function with uniform efficiency over the whole wave length band. As you know, it has usually been necessary to introduce losses in the form of voltage reducers in the filament or plate circuit to get stable operation; and to vary these controls as the wave length is varied in order to maintain a satisfactory condition, since for reasons which will be explained later, the conditions in the circuit keep changing as the tuning of the set is varied.

An ideal radio frequency circuit is one that provides maximum and uniform efficiency over the entire tuning range; one which requires no adjustments to maintain this condition, the only controls being those to tune in stations and to vary the volume to any desired level. Loftin and White have attained this ideal by developing a new system of coupling, and a system of suppressing oscillations. By combining with the regular inductive coupling a electro-static coupling, automatic compensations are made for the deficiency of the inductive coupling on the high wave-lengths, resulting in a uniform transfer of energy. The oscillations are suppressed

by a clever method of phase difference between the input and output circuit of the vacuum tube.

The following is a simple explanation of how the difficulties which are so common in tuned radio frequency amplifiers are over-come in the Loftin-White circuit: Fig. 3 shows the usual transformer or inductive coupling. The numerals 1 and 2 represent the primary and the secondary, respectively. The inherent characteristic of such a transformer is to convert more energy to the secondary (and succeeding tube) at higher frequencies than at the lower. This is illustrated graphically in figure 4. The vertical line represents the voltage transfer to the secondary, and the horizontal line the frequency and the direction in which it is increased. It may be observed that the coupling, or energy transfer *increases* as the frequency is increased (wave length decreased). Since a specific coupling is required in a transformer for a particular tube, it can be seen that the amplification will increase at the high frequencies and fall off at the lower frequencies (higher wave lengths), thus being "optimum" coupling over a narrow band of frequencies only. If the coupling is adjusted for best amplification at the middle of the broadcast band, the amplification will fall off at the higher wave lengths, and at the lower wave lengths due to the increased coupling, the amplification will increase to such proportions (due to the coupling increase) to cause the tube to oscillate.

An electro-static coupling can be so arranged to produce an effect exactly opposite in characteristic to that of inductive coupling. Fig. 5 is a simple diagram showing how it is done. This circuit is equivalent to circuit Fig. 3, 1 being the primary circuit and 2 the secondary circuit. The fixed condenser takes the same place in the plate circuit as does the primary of a transformer. However, the variable condenser here is also a factor in determining the coupling, for the *greater* the ratio of the fixed condenser to the

variable condenser the less will be the energy transferred from 1 to 2. It can be readily seen that the values or proportions of the fixed condenser to the variable condenser will change as the capacity of the variable condenser is changed to tune the secondary 2. Assume for instance that when the variable condenser is all the way in (tuned to highest wave station) the values of the two condensers are equal, and we will say that the coupling is 50 per cent, now if the condenser plates are turned half way out, or to half the maximum value, the fixed condenser composes two-thirds of the whole value (ratio 3 to 1), bring the coupling or energy transfer down to 33.3 per cent, for the voltage developed across the fixed condenser is *inversely* proportional to its ratio with the variable condenser.

Suppose the variable condenser plates are turned out still farther, so that the condenser will have only one-fourth the original value, then the variable condenser will be only one-fourth as large as the fixed condenser, and the coupling will be only 20 per cent. Taking actual values, the maximum capacity of the variable condenser might be 500 m. m. f. (.0005 m. f.) and the capacity of the fixed condenser 500 m. m. f. The minimum capacity of the variable condenser we will assume to be 50 m. m. f. With the variable condenser at maximum the reactance across the fixed condenser will be half the total value or 50 per cent. With the condenser at minimum value to tune in the highest frequency station, the fixed condenser will be ten times as large as the capacity of the variable condenser, and consequently, the coupling will be only 9 per cent. This action is shown graphically in Fig. 6. It can be seen that the coupling *decreases* as the frequency to which the set is tuned *increases*, and is just *opposite* in its action to inductive coupling which increases as the frequency is increased.

Combining the two methods of coupling just outlined will result in the much desired uniform energy transfer for all fre-

quencies, provided that proper values are chosen to get a correct balance. Fig. 7 shows the circuit for combining inductive and electro-static coupling, and Fig. 8 shows graphically the result obtained in doing so. The uniformly high energy transfer is at any wavelength a result of the *sum* of the energy transferred by the coil and the condenser at that wavelength. Thus, it is possible to so proportion and combine a coil and a condenser in the circuit that the energy transfer will be maintained at the maximum point at all wavelengths, the inherent losses by one being compensated for by the inherent gains of the other. This is the backbone of the Loftin-White system of "constant-coupling."

Preventing oscillations in a tuned radio frequency circuit is still another story. This is brought about in the Loftin-White circuit by changing the phase relation in the plate circuit to that in the grid or input circuit. The principal cause of oscillation in radio frequency circuits is the feedback of energy to the input circuit through the capacity between electrodes of the tube. It is necessary, however, that this feedback be in phase with the impressed grid voltage, or input voltage, in order to produce oscillation. Feedback may be negative or positive. Naturally when the feedback is negative it will not aid in bringing about oscillation, and when it is positive it will encourage oscillation. With inductive reaction in the plate circuit (coil) the feedback will be positive because the voltage in the plate circuit will be almost in exact phase with the grid voltage. With capacitive reaction in the plate circuit the feedback will be negative and out of phase with the grid voltage, hence, no oscillation or regeneration. In the practical adaption of the Loftin-White circuit a small variable condenser is used in the plate circuit, in series with the primary of the transformer, to shift the phase to such a relation with the input circuit so that no regeneration, or a limited amount of regeneration takes place. This is called the "phasing condenser."

Every radio engineer immediately appreciates the tremendous possibilities offered by this circuit for improved reception in manufactured receivers, but it remained for the engineers and management of the Arborphone Division, Consolidated Radio Corporation, to design and manufacture a

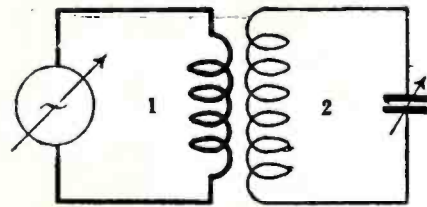

Fig. 3

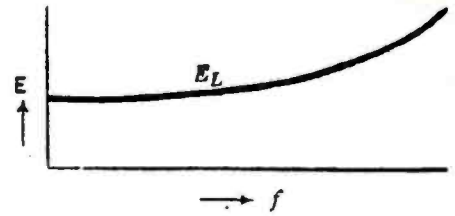

Fig. 4

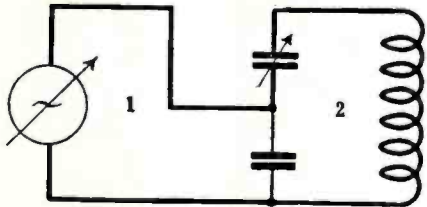

Fig. 5

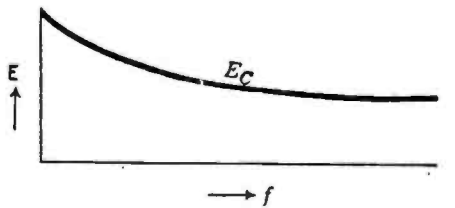

Fig. 6

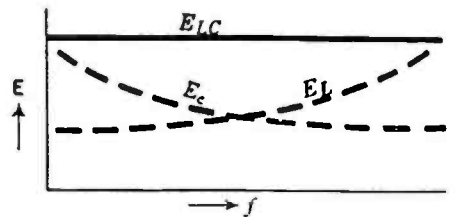
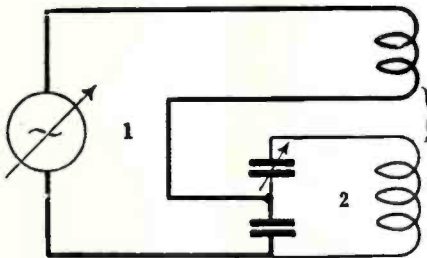

Fig. 8

Fig. 3. Usual transformer or electromagnetic coupling. Fig. 4. Graph of action of electromagnetic coupling. Fig. 5. Electro-static coupling. Fig. 6. Graph showing action of electrostatic coupling. Fig. 7. Combination of two couplings shown graphically. Fig. 8. Effect of combining the two couplings shown graphically.

visualized perfect receiver, with the Loftin-White circuit as an inspiration. In it they have incorporated some unique mechanical features of their own, which are interesting contributions to radio receiver design and manufacturing practice.

A single glance at their product, the new Model 25 Series Arborphone, makes us conclude that they have accomplished their objective. Figure 1 shows the completed receiver, and Figure 2 the circuit diagram. The circuit diagram it will be

noticed has distinctive features that are quite new. The condensers between the secondaries and the variable condensers are the coupling condensers, while the condensers between the plates and the primaries are the phasing condensers. The r. f. choke coils in the plate circuits are to prevent the radio frequency energy from going to the plate power supply instead of taking the proper path through the phasing condenser, the primary of the transformers, and the coupling condensers to ground. Choke coils are used in the grid returns for the same purpose. It is interesting to see that a negative bias of four volts is applied to the grids of the radio frequency tubes, through the chokes. This cuts down the power consumption and increases the selectivity of the set by virtue of increasing the input impedance of the tubes.

By adjusting the phasing and coupling condenser in each stage the receiver can be made to maintain a very sensitive state over the whole broadcast range. With these adjustments the set can be put into a state of regeneration, and yet without oscillations, over the whole band. Resistance introduced into the circuit by close shielding can be compensated for by the condition of regeneration, or "regenerative contribution." The circuit adjustments

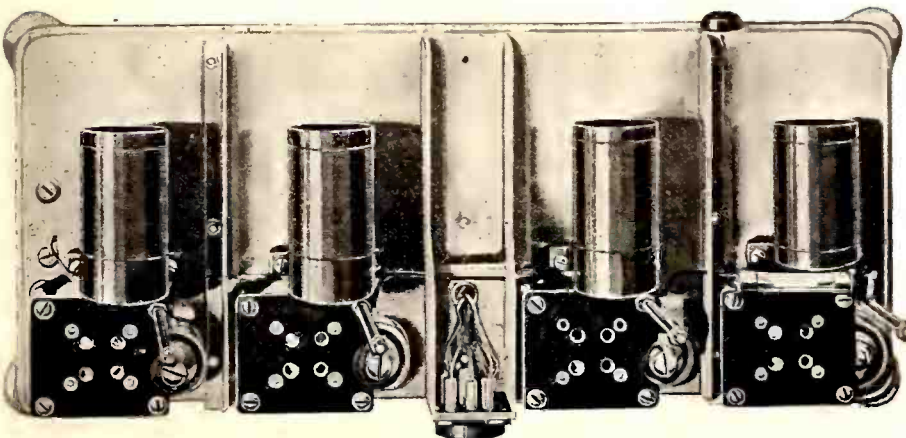

Fig. 9. The Arborphone radio frequency chassis showing rugged construction

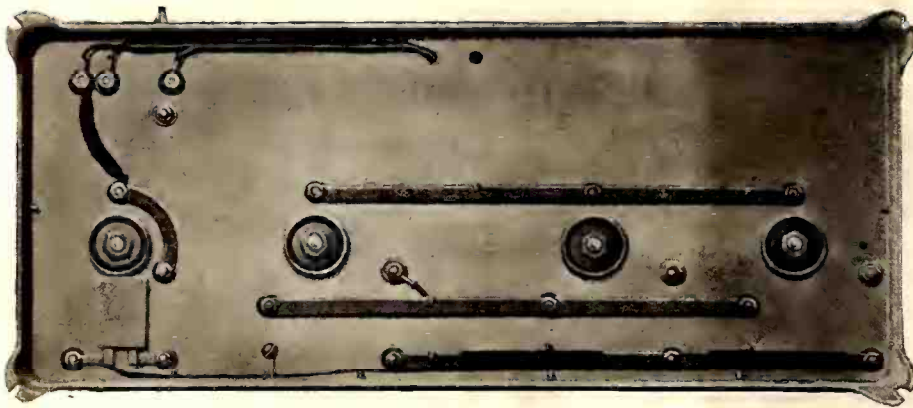

Fig. 10. Underside view of Arborphone chassis showing simplified construction

are all made at the factory and remain "put" indefinitely. Even variations in tube capacities will not unbalance the set.

The new design has four full tuned stages, three stages of radio frequency ahead of the detector, controlled by a single dial. It is positively single dial control, once a knob on the panel adjusts the antenna secondary circuit to the particular antenna with which the receiver is to be used, except possibly for a now-and-then refined adjustment of this knob in extremely long distance reception.

Complete double shielding is employed, each of the three radio frequency stages and the detector (four tuned stages) being inclosed in its own fully shielded compartment (see figure 1), but each compartment is no larger than physically needed to house the necessary parts for a stage. As a result, the four compartments form the interior of a metal box condensed to the dimensions of 12 inches long by 6 inches wide. Yet, by reason of the Loftin-White circuit this unheard-of close shielding is accomplished without loss of efficiency from absorption.

In the Model 25 Arborphone a distinct step forward has been made in the mechanical construction of radio receivers. Each compartment for a radio frequency stage is so dimensioned and the apparatus in it so located that it is the exact mechanical equivalent of every other compartment, and each rotor of the 4-gang

condenser moves identically the same in relation to the apparatus in its own compartment. In effect, by thus making the compartments exact mechanical equivalents and maintaining them so at every point on the broadcast band, a decided engineering step has been taken toward the necessary maintained electrical equivalency for successful single dial control.

The inductance and coupling coils, choke coils, coupling condensers, and phasing condensers peculiar to the Loftin-White circuit for each stage are built into compact units around a tube socket. Most of the electrical connections between these elements are permanent structures, eliminating the usual maze of interconnected wires soldered to clips. Figure 9 is a view of the Model 25 Arborphone chassis base, showing the compactness, clean-cut appearance, simplicity, and beautifully balanced layout of these units.

Each unit is the exact counterpart of every other one, so that they can all be assembled and tested before inserting into the complete receiver. Greater accuracy of assembly results, and freedom from imperfect connections caused by soldering in inaccessible places after the parts are all located in the cabinet or shielding compartment. This, too, is an interesting departure in mechanical practice and seems to be distinctly better.

Four of these perfectly assembled and tested units are mounted on a chassis that

forms the base of the shield box. There is but one wire connection between one unit and the succeeding one, and one wire connection between each unit and its own gang-condenser unit. In brief, the unsightly and difficult wiring common to some radio receivers has been eliminated in this design, freeing it from loose connection difficulties. Figure 10 is the under side of the chassis base, showing the highly simplified and permanent character of the wiring. Except for the two connections referred to above, this is all there is to the wiring.

Oil-filled Cables in Use

The latest development in underground transmission of electricity was described by Arthur Williams, Vice-President in charge of Commercial Relations, of The New York Edison Company, in a radio talk over station WRNY.

Mr. Williams told of an underground cable that has an oil-filled core its entire length of 12 miles and that carries twice the amount of electric energy carried by the underground cables generally in use today. The new cable promises, Mr. Williams said, to have a large future influence upon the efficient distribution of electric energy. The 12 miles of oil in the center of the cable is about three-quarters of an inch in diameter, is surrounded by 132,000 volts of electrical pressure and about 125,000 horsepower of electric energy—a higher pressure, a greater amount of power, and a longer distance than has been possible of accomplishment in underground transmission in the past, he said.

New Zenith Sales Manager

Paul B. Klugh, Vice President and General Manager of the Zenith Radio Corporation, Chicago, announces the appointment of Thomas H. Endicott as sales manager. This executive position was made vacant in August when the former sales manager, N. A. Fegen, resigned in order to become a wholesale distributor of Zenith in Cleveland and northeastern Ohio.

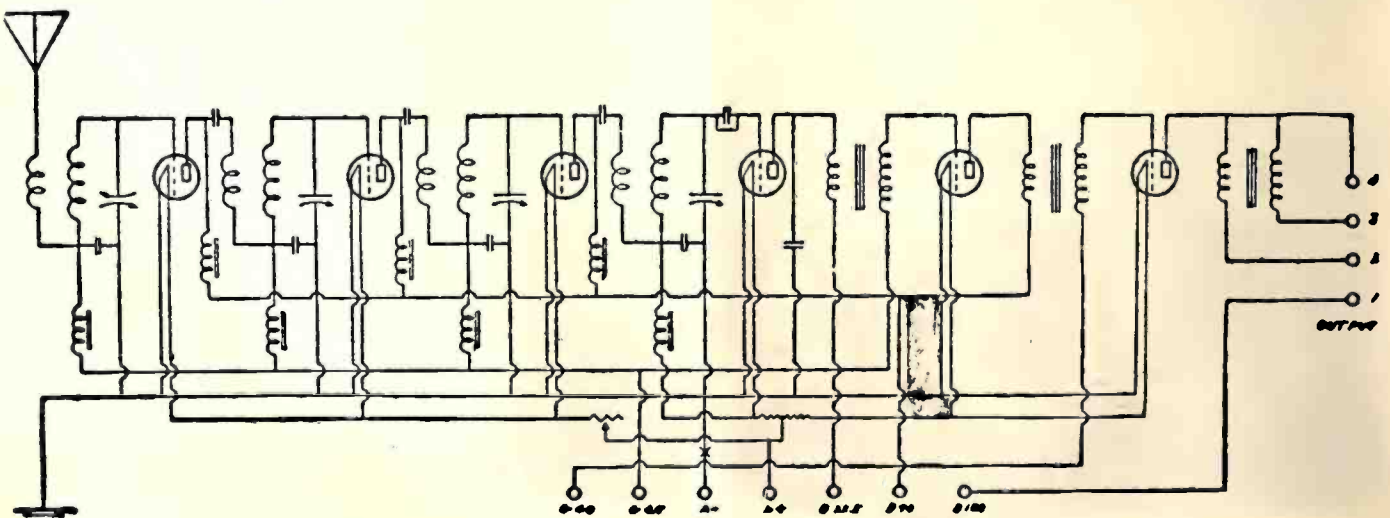

Fig. 2. Circuit diagram of the Arborphone Receiver

Power Tube Puts Music into the Set

THE development of the power tube and suitable equipment associated with it has been without a question the biggest boon towards making the radio set a musical instrument. Even the improvements in the design of audio frequency transformers are not as great an asset towards quality reproduction as is the power tube. Few people realize that their old set, whose tone is so inferior in contrast to that of a modern receiver can be made to sound like a modern set, or nearly so, by adding the proper equipment. Nor is it necessary to make radical changes in the receiver itself to bring this about.

Most of the receivers which were built or bought three years ago still use the 201A type of tube in the last stage of the audio amplifier—and there are still many such receivers in use today. The engineering world, and most of the people associated with the technical or sales angle of the radio industry have been educated to the fact that a loud-speaker can not be operated satisfactorily from the output of the 201A, the WD12, or the "99" tube. However, to many of the people who are not interested in the technicalities of the radio set, there is little meaning in the type of tube used in their set. When they go to a radio store for replacements they merely ask for the type of tube corresponding to the old one in the set, and as a result have never made the proper changes which entails small expense and promotes a worthy cause.

It is our aim here to explain the difference in the various types of tubes and how these tubes should be used. The general purpose tube of today (201A type) is still very similar in its characteristics to the tube of four or five years ago. At that time the tube was designed as a voltage amplifier, as is the same tube now. As a voltage amplifier no power is actually taken from the tube. The purpose is to amplify the voltage across the primary of the detector tube circuit to as large a value as is possible without distorting the original form, and impressing the same on the succeeding tube. The tube itself is a voltage operated device and takes no current from the transformer which is working into it. In the last stage power is actually taken from the plate circuit of the tube and expended in the reproducing unit (phone or loud speaker). At ninety volts plate supply the *undistorted* power obtainable from a 201A type of tube is only about 15 milliwatts. Just about enough power to operate the diaphragm of a pair of telephones to a comfortable listening volume. When more power is taken from the tube than 15 milliwatts nothing but distortion can possibly be obtained.

Fortunately, — or unfortunately — few people will recognize distortion until it



Edward Manley, radio operator of the *Morrissey* on which he "copied" 310 stations in this and many other countries while the Putnam-Baffin Island Exposition was in Fox Basin. He is seated before his dry battery-powered radio receiver

exceeds 50 per cent. Some can not be convinced that their radio set sounds "terrible" until an actual comparison with that which is almost perfect is made. They have been listening to this poor reproduction so long that they have become accustomed to it. A loud speaker operated from the out-put of a general purpose tube is utterly hopeless. Applying 135 volts to the plate is some improvement—the undistorted power out-put is increased to about 50 milliwatts.

The smallest power tube, the 112 type, makes available a power out-put of 120 milliwatts at 135 volts plate potential; more than twice as great as the 201A type at its best. This is also an improvement, but still not enough power to operate a good loudspeaker to full volume. At 157 volts the out-put increases to 195 milliwatts,—still better, and good enough to operate a speaker for comfortable one-room volume without noticeable distortion. The 171 power tube has an undistorted power output of 700 milliwatts when operated with a plate voltage of 180 volts. This affords very good reproduction on a good loudspeaker and will fill a room with plenty of volume.

It seems ridiculous, then, to try to get loudspeaker volume from a tube capable

of delivering an output less than one-twentieth of that required for good reproduction.

The proper grid bias is specified with each tube, and must be followed if undistorted reproduction is at all expected. The larger the power output of the last tube the greater will be the voltage changes required on the grid of the tube. This voltage is derived directly from the transformer or other device working into the tube. The out-put follows with the amplitude of the voice or music voltage impressed on the grid, the larger the grid voltage the larger the power out-put. Under ideal conditions a sinusoidal wave is impressed on the grid of the tube—that is the positive portion of each sine has the same form as does the negative.

To preserve this condition the grid of the tube must never be positive, but more negative and less negative, following the alternate negative and positive potential from the secondary of the transformer. The C bias must, of course, be large enough to take care of this, for if say, an alternating current of twelve volts is applied to the grid of the last tube (power tube) and the grid bias potential (C battery) is only nine volts, it is apparent that

(Continued on page 43)

Robertson-Davis Hot Spot Fourteen

By FRANK FREIMANN

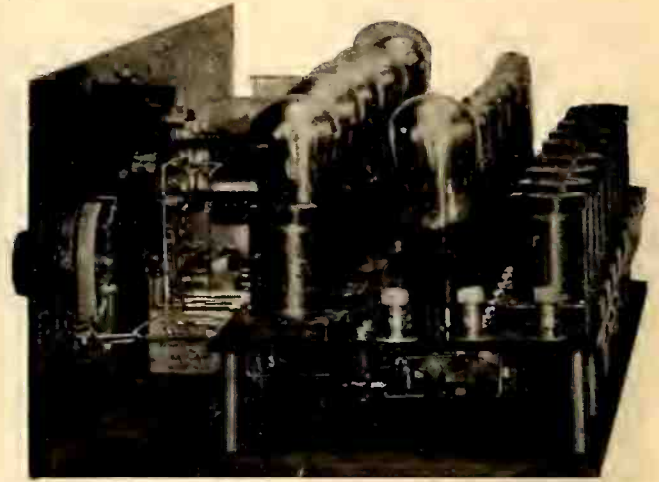

THE theory that any number of amplifying stages may be cascaded with an amplification gain in each stage, provided that the gain per stage is limited to a comparatively low value, has been put to practice in the late Robertson-Davis development—the Melo-Heald Hot Spot Fourteen. Dr. A. W. Hull points out in one of his recent articles that radio frequency amplifiers may be added stage after stage until a tremendous amplification is built up if the amplifier is designed to give an amplification gain of not more than four per stage.

One naturally scoffs at the thought of limiting the amplification of a tube and transformer to a value only four times as large as the input voltage, when the tube is capable of producing a much higher amplification. On second thought—or perhaps third—one begins to realize the possibilities in an amplifier which has only half the regular amplification but twice as many stages. Taking for instance the average three stage amplifier with an amplification gain of about ten per stage; the total amplification will be one thousand. With an amplifier using four stages at a gain of six per stage the over all amplification is 1296. In an eight stage amplifier with a gain as low as three per stage, the over-all gain will be 3⁸ or 6,561. It is well known that when a two tube amplifier is designed for maximum amplification per stage another stage can not be added with a resultant gain equal to the product of the additional stage of amplification and the amplification of the first two stages. The tubes will start oscillation, due to the feed back of energy into the input circuit. The amplification

List of Parts for "Hot Spot" Fourteen

- | | |
|---|---|
| 1—Robertson Davis Certified Melocoupler No. 420 | 5—Sangamo 1 mfd. By-pass Condensers |
| 1—Robertson Davis Certified Melocoupler No. 460 | 1—Yaxley 4 ohm Fixed Resistance |
| 1—Robertson Davis Certified Melocoupler No. 461 | 1—Yaxley 3 ohm Semi-Fixed Double Arm Base Mounting Resistance |
| 1—Robertson Davis Certified Melocoupler No. 462 | 1—Yaxley 6 ohm Semi-Fixed Double Arm Base Mounting Resistance |
| 1—Robertson Davis Certified Melocoupler No. 463 | 1—Yaxley 400 ohm Potentiometer |
| 1—Robertson Davis Certified Melocoupler No. 464 | 1—Yaxley 3 ohm Rheostat |
| 1—Robertson Davis Certified Melocoupler No. 465 | 2—Hammarlund .0005 mfd. Midline Variable Condensers |
| 1—Robertson Davis Certified Melocoupler No. 466 | 1—Hammarlund .00032 mfd. Midget Condenser |
| 1—Robertson Davis Certified Melocoupler No. 467 | 2—Kurz-Kasch Dials |
| 1—Robertson Davis Certified Melocoupler No. 468 | 1—Frost 200,000 ohm Potentiometer with Filament Switch |
| 1—Robertson Davis Certified Melocoupler No. 469 | 1—Jewell 0-7 1/2 -150 Voltmeter |
| 1—Robertson Davis Melo-Choke | 1—Jewell 0-100 Milliammeter |
| 3—Robertson Davis Multistage Meloformers | 1—Formica 7x30x3/16-inch Drilled and Engraved Panel |
| 4—Benjamin Spring Sockets | 1—Formica Drilled Sub-panel |
| 1—Jones Cable Plug, Type BM | 1—10x29x1/2 inch Wood Base-board |
| 8—X-L Binding Posts | 1—Package Kester Radio Solder |
| 2—Sangamo .006 mfd. Fixed Condensers | Miscellaneous nuts, screws solder lugs. |
| 1—Sangamo .00025 mfd. Grid Condenser with Clips | 1—Durham 4 megohm Grid Leak |
| | 30—Feet Acme Celasite Wire |

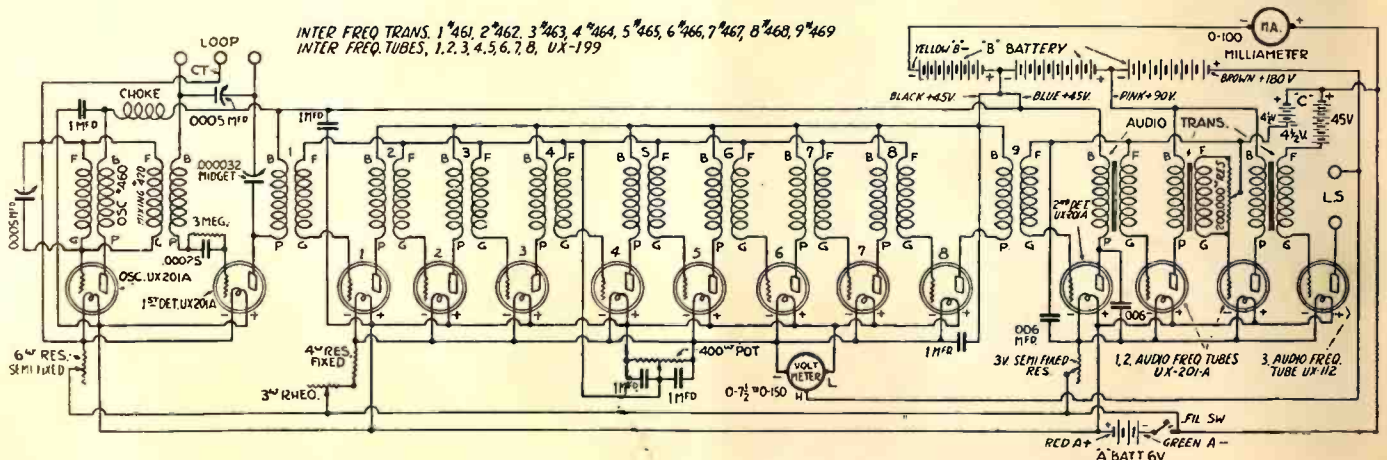

Figure 3. Schematic circuit diagram of the Melo-Heald Hot Spot Fourteen

of each stage must be decreased until oscillations cease, which results in a much lower over-all gain. (Amplification contributed by the regeneration when the system is operated just below the point where oscillations start is not considered here.) Thus, a four stage amplifier designed to give a gain of ten in each stage will not deliver a voltage amplification of 4,000 because before such proportions are reached oscillations will start.

For this reason, heretofore, amplifiers have been limited to three or four stages. More stages resulted in nothing but a very unstable radio set with apparently not much more gain in amplification for the additional tubes and transformers. In the Melo-Heald Hot Spot Fourteen advantage was taken of the fact that when the amplification in each stage is low enough the feedback of energy from plate to grid and from the following stages will not be great enough to start oscillations. Naturally, the set is very powerful. Great amplification may be expected. Great amplification will be obtained.

As its name implies, fourteen tubes com-

are oscillation control for the intermediates, volume control, and filament voltage control for the type 199 tubes which are used in the intermediate frequency circuit. Flexibility as well as easy tuning is apparent. The photograph of the rear view illustrates the well equalized layout of parts and wiring. The transformers, tubes, bypass condensers, etc., are mounted on a sub-panel.

The intermediate frequency transformers are designed so that stations can be heard on only one setting of the dials. This is accomplished by operating at a comparatively high frequency of 465 KC. When the intermediate stages are tuned to this frequency the oscillator must have a range from 1000 to 2000 KC to reproduce a beat frequency (intermediate frequency) of 465 KC when combined with any of the broadcast frequencies. The "other setting" would be between 185 and 950 KC, which is for the most part out of the broadcast frequency band, therefore these settings produce no interference from other local stations.

Similarly, low wave stations below

stations. This freedom from repeats and interference is one of the chief merits of the Melo-Heald "HOT SPOT."

The set tested in the RADIO AGE laboratory performed splendidly. Selectivity was there for certain, and in the most perfected form. The tuning is remarkably smooth; stations slide in and out without the frequent smearing of the local station over the DX station ten kilocycles away. In other words, the ten kilocycle separation applies to local stations as well as to those remote. On a good night a station will be found on practically every channel. The West Coast stations came in with pep, including one or two that were not heard before. Another point of vantage is the low response to static the receiver has. It is by no means a "static eliminator," but static is diminished more than it is on a super working at a relatively low frequency.

The schematic wiring diagram is shown on blue print pages. It can be seen that the mixer circuit (oscillator and first detector) is a distinction from the customary. Two coils are in parallel, the oscillator grid coil and the coil coupled to the

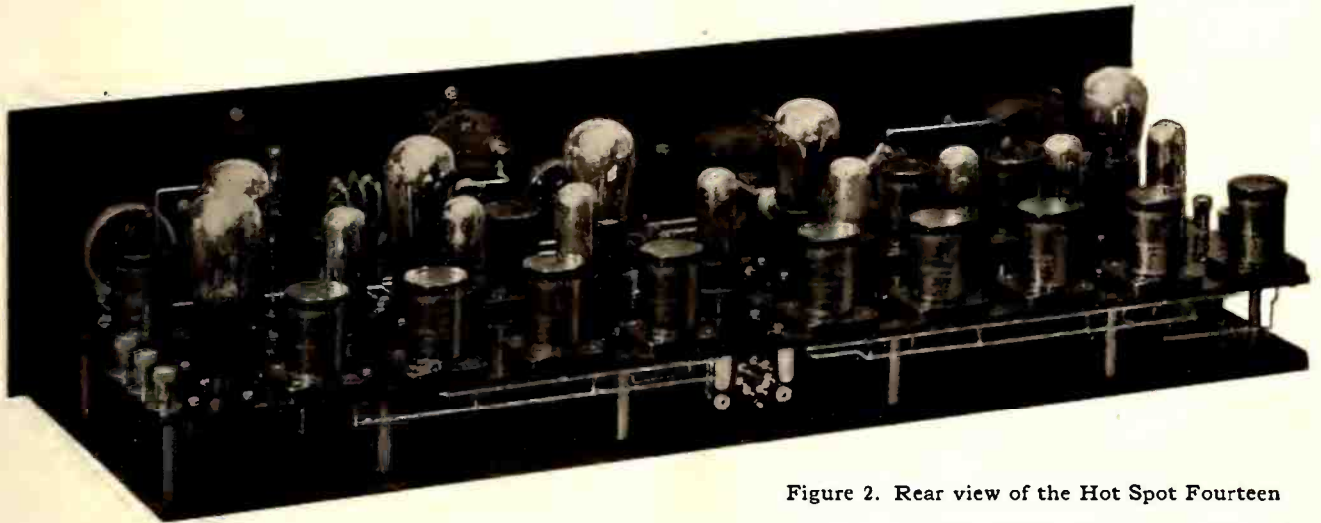

Figure 2. Rear view of the Hot Spot Fourteen

prise the glass works; fourteen transformers complete the army of voltage amplifiers. Each unit does its bit and does it well. With their combined efforts infinitesimal impulses which have been worn down on their long journey across the continent are built up to the volume of the original sound that activates the microphone in the studio a few thousand miles away. This is the first time to our knowledge that such an elaborate combination has been made practical. Not only has the set tremendous power, but also the much desired capability of discriminating between the local ether bombardiers and the stations in New York, Seattle, or what-have-you. The music is clear and sweet, too, even though it has traveled far and has to compete with a shower of static here and there.

Figure 1 shows the neat front panel appearance of the HOT SPOT 14, and Figure 2 a rear view of the set. The two major controls are the loop tuning condenser and the oscillator tuning condenser. A Jewel milliammeter and a voltmeter show constantly conditions under which the set is operating. The small knob between the two main tuning controls offers very sensitive control of the regeneration in the loop circuit. The three remaining controls

(1000 KC) in the close proximity of the receiver cannot reappear on the upper part of the dials. This parasite is caused by the second harmonic of the oscillator (doubling the oscillator frequency) falling on one of these stations when the oscillator is tuned to the high wavelengths. However, in this super-heterodyne the range of the second harmonic is between 2000 and 4000 KC and is again out of the broadcast frequency range. The range of the second harmonic frequency of super-heterodynes operating on a comparatively low frequency is between 900 and 3000 KC making the receiver susceptible to "repeats" of the low wave stations if they are very powerful, unless the input circuit is selective enough to eliminate these

detector circuit, this has the effect of increasing the oscillator frequency to that required for the intermediates, and at the same time affords very close coupling. The first two units comprise the oscillator and mixer circuit, the following nine transformers are the intermediates, while the last three are the audio transformers. The whole system consists of the oscillator circuit, first detector circuit, eight intermediate frequency stages, second detector, and three stages of audio frequency amplification. In the first detector rectification is procured by means of the grid condenser, and in the second detector by means of a $4\frac{1}{2}$ volts grid bias. The 400 ohm potentiometer is employed to control the amplification and tendency towards



Figure 1. Front view of the attractive Melo-Heald Hot Spot Fourteen

JEWELL 675716 VOLTS - P4732

JEWELL 6700 MILLI - AMPERES - P4732

SELECTOR I

SELECTOR II

DRILLING FOR KURE-MACH DIALS

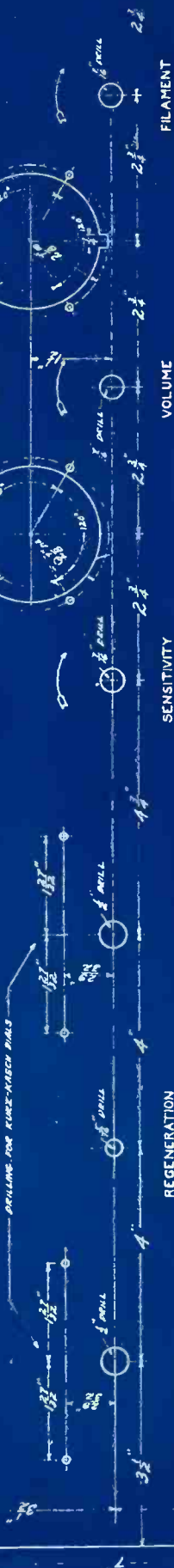

ALL HOLES .05 INCH UNLESS OTHERWISE NOTED

3"

6"

6"

3"

6"

6"

3"

3"

6"

3"

6"

3"

COUNTERLINE

PANEL DRILLING AND ENGRAVING TEMPLATE FOR "HOT SPOT FOURTEEN"
OCTOBER 1, 1947

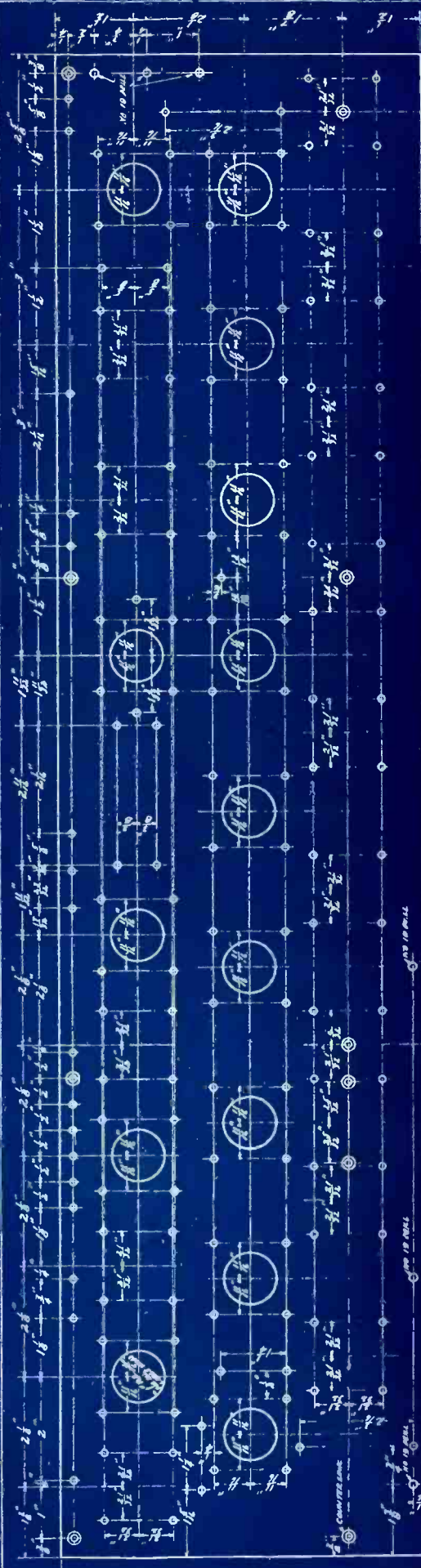

2 1/2"

1 1/2"

1 1/2"

1 1/2"

1 1/2"

1 1/2"

1 1/2"

1 1/2"

1 1/2"

1 1/2"

1 1/2"

1 1/2"

1 1/2"

1 1/2"

1 1/2"

1 1/2"

1 1/2"

1 1/2"

1 1/2"

1 1/2"

1 1/2"

1 1/2"

NOTE: ALL HOLES .05 INCH UNLESS OTHERWISE NOTED
 DRILLING TEMPLATE FOR "HOT SPOT FOURTEEN"
 SUB-PANEL
OCTOBER 1, 1947

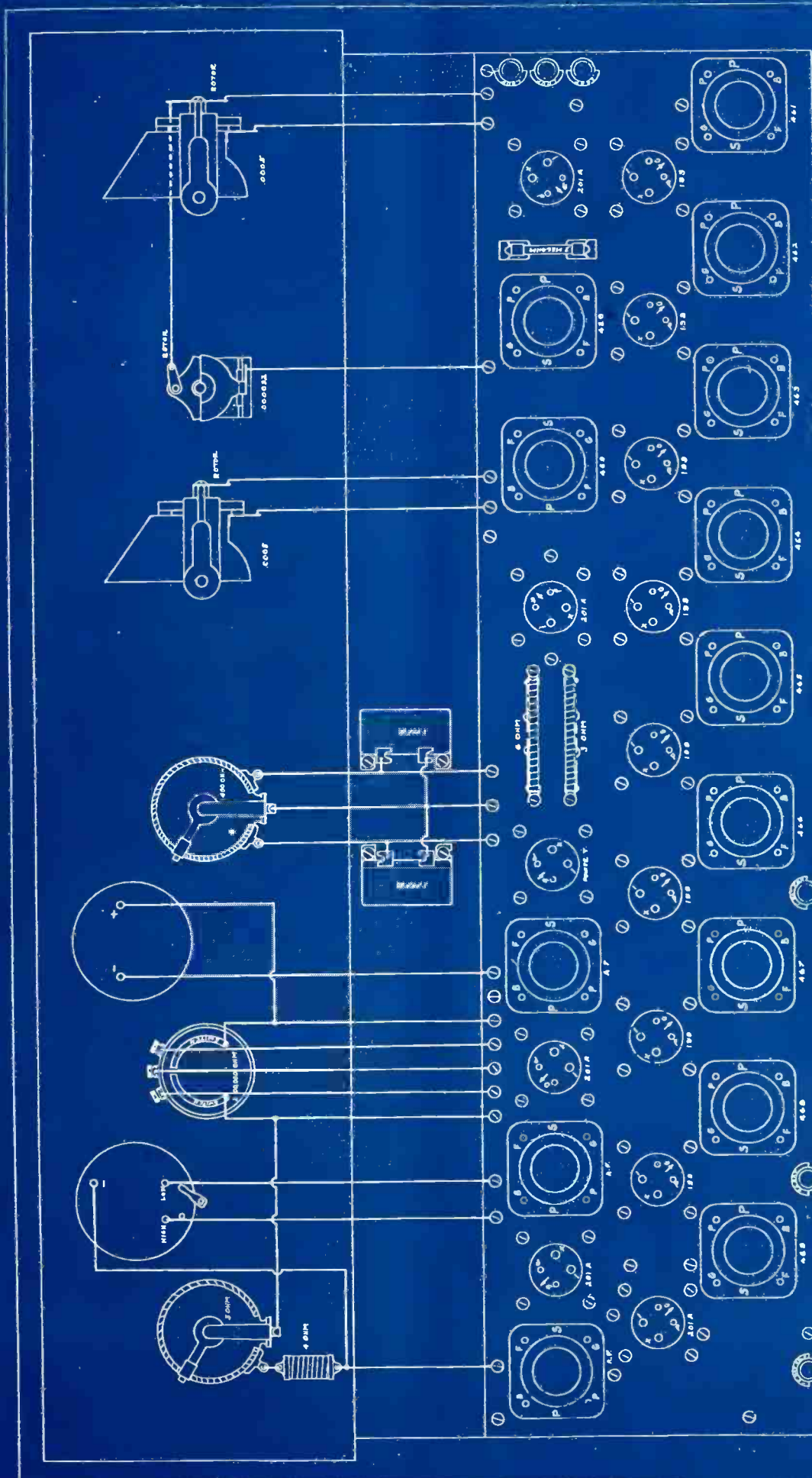

ASSEMBLY OF "HOT SPOT FOURTEEN"
OSCTRA 1-1927-47

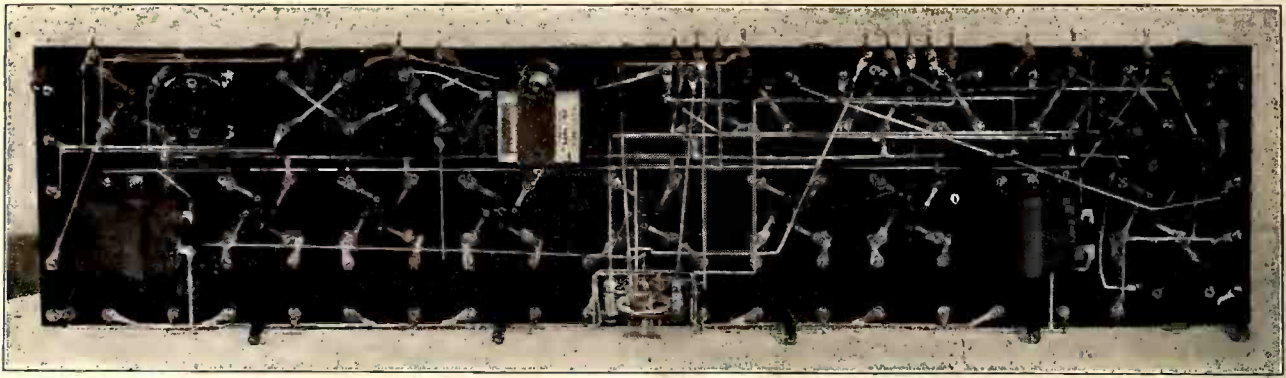

Figure 4. Bottom view of the sub-panel

oscillation in the intermediate amplifier. The three ohm rheostat provides control of the 199 tube filaments, the four ohm resistance in series with this rheostat limits the voltage so that the tubes can not be injured. The 200,000 ohm Frost potentiometer across the secondary of the second audio transformers provides a perfect

separate units, that is, all the necessary parts should be mounted on the sub-panel and front panel, and each panel wired as shown in the sketch of Figure 5, and the blue-print. When the assembly and wiring of each section is completed the sub-panel should be mounted on the base board on pillars of metal rods as shown in the

mounted only a dozen joints need be unsoldered to set the sub-panel free from the front panel.

The layout for the front and the sub-panel is in the blue-print section. The dimensions can be transferred to a panel that is to be drilled. The drilled and engraved panels for this set may be obtained

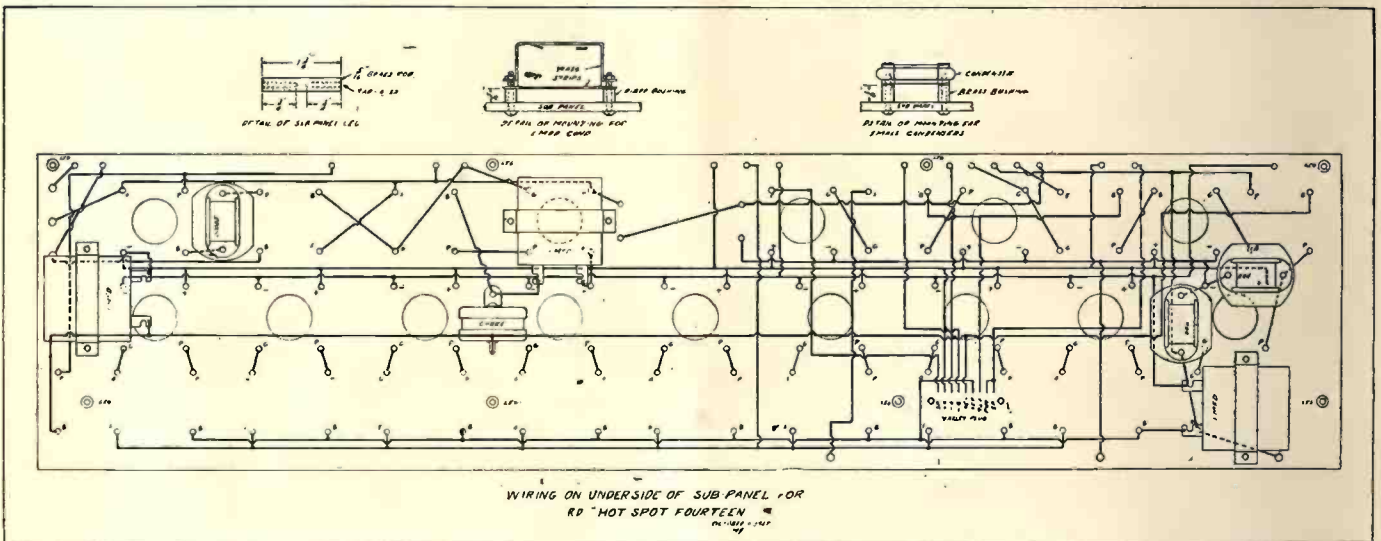

control of volume. On this potentiometer is mounted a filament switch by means of which the filaments are automatically turned on when the knob is moved towards maximum volume position.

The set should be assembled as two

various illustrations. Then mount front panel in its place. After the set is completely mounted the two panels should be connected together in the manner pictured in the blue-print. Should it be necessary to get beneath the sub-panel after it is

through your radio dealers.

Enough photographs showing the completed set at all angles are shown in this article to make the building of the Melo-Heald Hot Spot simple. Follow the wir-

(Continued on page 45)

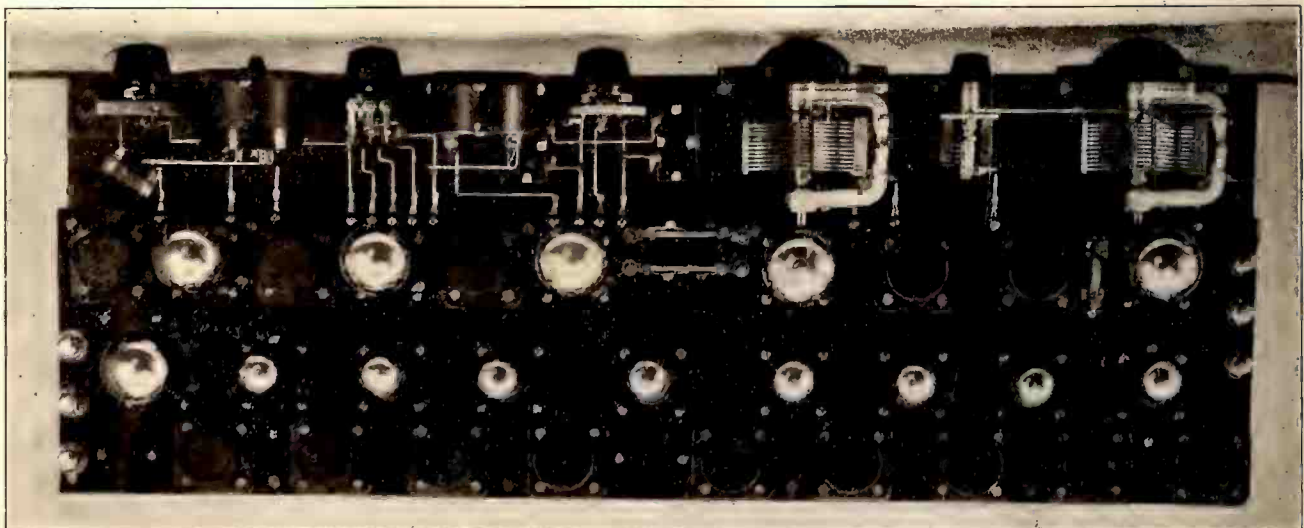

Figure 8. Top view of the completed set

A Constant Voltage B Eliminator

This B power unit is designed for the Quadrode Super-Heterodyne or any other highly sensitive Super receiver.

IT is commonly known that the requirements of a B power unit are, first, that it should deliver sufficient current at the required voltage, with no hum; second, that the voltage remain constant under varying load conditions. All power units do not come up to these specifications, and yet for some purposes the eliminator will fill the bill very nicely. Especially so for receivers employing not more than five tubes. When however, as in many cases, a B power unit that worked satisfactorily on a five tube set is applied to a superheterodyne, the results will be all but satisfactory. Sometimes the unit is incapable of delivering sufficient current to the set, and naturally the set will not perform to the best of its ability. Also the set is apt to "motor-boat" for this reason, or "hum" because the choke coils in the filter system are saturated.

One of the most frequent failings of a B power unit when used with a large set is that the voltage drops much lower than that required for good operation, and that it varies with adjustments made on the receiver. This can be largely compensated for by the addition of a voltage regulator tube which will keep the voltage constant regardless of load conditions, provided that the power unit can supply sufficient current. This should be about seventy milliamperes, and means that the 85 milliamper type of rectifier tube such as manufactured by the Raytheon Manufacturing Company, or similar tube must be used. A transformer having voltage of 300 on either side of the center tap should be used, and also the choke coils should be capable of carrying 85 milliamperes without saturating.

The Raytheon Manufacturing Co. have recently turned out a very fine regulator or "R" tube. The advantage of this tube over all preceding tubes on the market is that it can be connected directly across a 90 volt potential and it will immediately begin to function, where previous tubes required a potential of 120 volts or more before the gas in the tube would ionize and the tube work. This advantageous condition is realized by the addition of a "starting anode" within the tube, along with the usual or "running anode." The "starting anode" is much closer to the cathode than the usual anode and therefore requires much less voltage to "ignite" or start ionization of the gas. Due to the low voltage required to start the tube it will not go out when a large load is

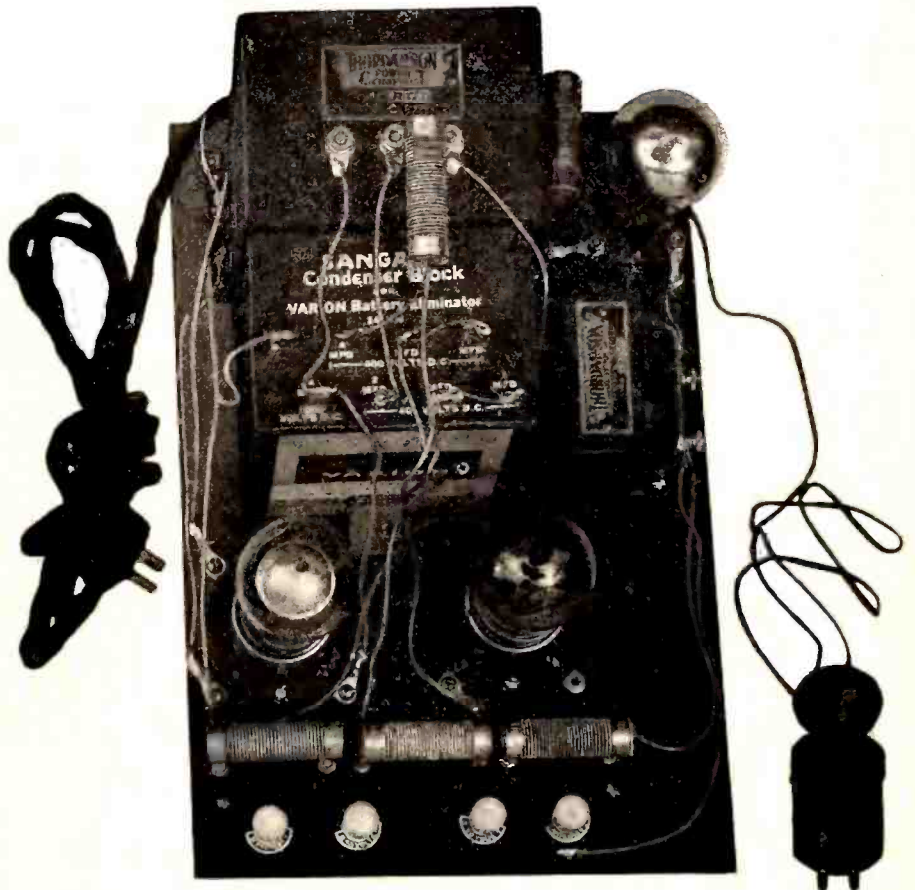

An easily constructed B power unit for superheterodyne receivers

taken from the eliminator as other regulator tubes do.

The tube can be used to an advantage on many B power units that are not at present supplied with such a device. The cathode is connected to the minus B terminal, the running anode to the 90 volt terminal, and the starting anode may be connected through a 40,000 ohm resistor to the highest voltage tap on the unit.

The tube not only keeps constant the voltage on the 90 volt and 45 volt terminals but also adds to the filtering effect of the eliminator. With it no "motor-boating" will take place.

The simple B power unit to be here described has the features being able to supply enough current for almost any radio set; its voltage will not vary under load conditions, it is "humless," and has provision for operating the power tube from a. c., thus making it possible to operate the receiver from an "A" power device having a capacity of about two amperes.

From the picture its construction is obviously simple, and with the aid of the

circuit diagram it can be wired by any one. The popular Thordarson R171 Power Compact is used for the voltage supply, the chokes being self contained; a Sangamo condenser block is used for the filter and by-pass system, and Electrad wire wound resistors are employed as resistor units. These resistors deserve mention since they are new on the market and of unique design. They are "wire wound," in the form of springs on insulating material, and are then wound on insulating rods. These resistors are able to dissipate a great deal of current without getting hot, and are very easy to mount.

The parts can be mounted on a suitable base-board. The picture is self explanatory and details are unnecessary.

The three Electrad resistor units for the plate voltage supply are mounted on a bakelite strip with four XL binding posts. If a couple of survivors of the dark ages in the form of metal top sockets are still in the junk box they can be brought to a more practical purpose by using them for the Raytheon BH rectifier tube and the voltage regulator tube. The

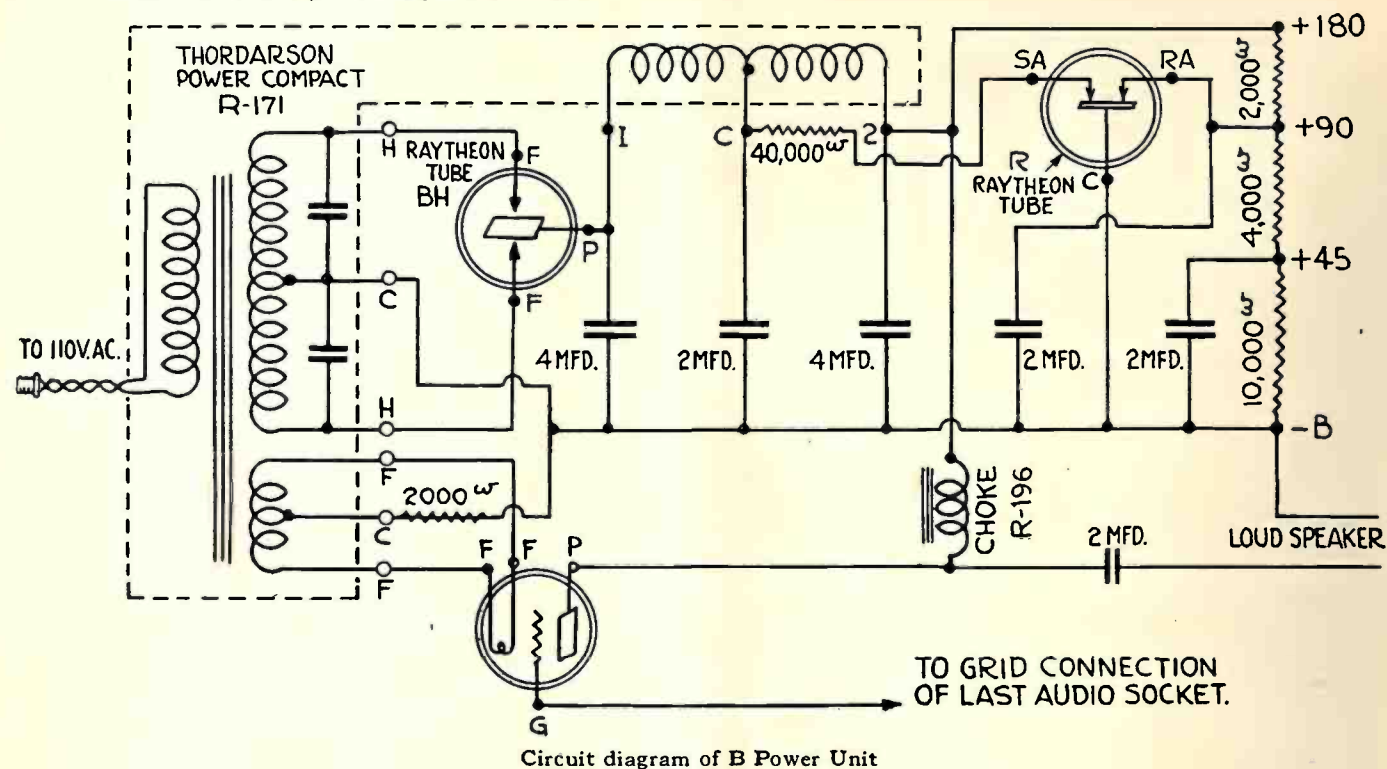

Circuit diagram of B Power Unit

starting anode connection is taken from the metal base of the voltage regulator tube. A permanent wire may be soldered to the metal part of the socket for this connection or a flexible stranded wire can be bent over the edge of the socket so that when the tube is put into the socket a tight electrical connection will be made. The free end of the wire can be fastened to one of the terminals on the socket that is not being used for another purpose.

A Frost socket is mounted on the right hand side of the power compact, the filament leads facing the filament supply voltage terminals on the compact. The connections can be made by soldering the two lugs together. The 2000 ohm resistor is mounted (one end) to the center tap of the filament winding and the other end connected to the center of the high voltage transformer winding on the other side of the compact. The voltage drop across this resistor furnishes an automatic bias for the power tube when the tube is operated from the filament winding.

The 40,000 ohm resistor in series with the starting anode is mounted directly to the center terminal of the choke coils (on top of the compact).

When the unit is to be operated as a B power unit only, that is, the power tube being right in the radio receiver, the four voltage terminals should be used as indicated in the diagram. However, when the power tube is put into the B supply unit the 180 volt terminal can be left disconnected and the loud speaker terminals should be connected as shown in the diagram. One to the negative B terminal and the other in series with a 2 mfd. condenser to the R-196 Thordarson Choke Coil and plate of power tube. The 2 mfd. condenser is employed to prevent d. c. current from flowing through the loudspeaker windings.

The tube socket plug is put into the last audio tube socket in place of the power

tube when the latter is operated in the power unit. The wire is connected to the grid terminal of the tube socket in the unit. Be sure to connect the wire which otherwise is connected to the minus C 40 volts to the negative B terminal when the power tube is not used in the set itself.

It is very apparent that variable resistors are unnecessary since the regulator tube takes care of all loads and keeps the voltage across the 90 volt terminals, and to a considerable degree across the 45 terminals, constant.

A Deep Note Speaker

Tastes in musical quality differ but the great majority prefer a deep rich tone, which accentuates the mellowness and harmony of the selection, even if the high notes of vocal selections are slightly modulated. The average user of a radio set desires music while he reads the paper

or while dining. For this purpose a tone chamber has been developed by Dray Laboratory, Chicago, which removes all the clash and startling peals which are so disturbing to one who desires relaxation.

The construction of this tone chamber is unique in that it is composed of alternate layers of cement and burlap. These layers are placed on the form by hand till the required number are present. This combination has an almost unbelievable power for absorbing vibrations of a high frequency while those of lower and moderate pitch pass unimpaired.

The horn is so mounted in the console that all vibration is carried direct to the floor and so distributed there will be no disharmonic overtones. It is advised against placing the receiver on top of the speaker for then vibration will be transferred to the tubes, resulting in howling.



The Long Air Column Dray Deep Speaker

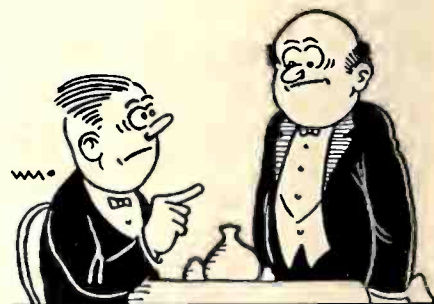

—“See here waiter, why can’t I have soup if I want it?”

—“Sorry, Sir, but we have orders not to serve soup when our orchestra is broadcasting.”

Angry Customer: “You call these safety matches? Why, none of them will strike!”

Shopkeeper: “Well, you couldn’t ‘av anything safer than that, could you?”



The Screen Grid Tube And How to Use It



THE official announcement that the new screen grid tube CX322 would be soon available to the radio trade has created more enthusiasm than ever in circuits that are applicable to this latest development in the tube industry. There is much curiosity afoot. Questions are asked: What about it? Can this tube be used in my present set, if not, why not? etc. Another frequent question is: Is this going to bring about any radical change in the radio receiving situation, and is it going to render present receivers obsolete? In this article we endeavor to bring light to these questions and satisfy many curious minds.

In the first place the screen grid tube can not be used in the average present receiver. In some cases where proper shielding is already installed it is possible to make changes in the wiring and a few little additions, besides the tube itself, to bring this about. Next the new tube will have no "over night" revolutionary effect on the radio trade. The coming of the AC tube brought about no radical changes; sets for DC operation are still being sold, and so it will be with the newest tube, the XC322. Next season no doubt there will be many sets on the market in which the new tube will be used; nevertheless, due to economical manufacturing and other factors the radio set as we know it today will still be in general use. It is certain, however, that these new tubes will be instrumental in providing radio receiving sets with a range far greater than anything we have today.

Perhaps before many moons the reception of West Coast stations in the eastern part of the country, and vice versa, will

no longer be considered a feat. The atmospheric conditions and interference from other stations will be the only limitations in getting distance. There is no doubt that with this new method receivers can be built with amplification great enough to reach the "noise level" (the point where infinitesimal noises are as great or greater than the station signal) in any location, be it in a noisy congested area, or atop a high mountain.

Last month a little detail was given on the appearance, externally and internally, of the shield grid or screen grid tube. It was pointed out that, except for the metal cap on top of the bulb the tube has the same geometric dimensions, and the same UX base as the ordinary general purpose tube. The filament current consumption is .132 amperes (about half that of the 201A) at a voltage of 3.3 volts. The other voltage requirements are as follows: 135 volts for the plate, 45 volts for the screen grid (for r. f. amplification), and 1.5 volt negative bias for the control-grid, that is, the grid which serves the same purpose as the grid in the general tube.

The elements within the glass bulb are the big departure from the tube with which we are so familiar. First, as has already been mentioned, there are four instead of three elements. The control grid, cylindrical in form, is arranged in a manner similar to that of the CX-299, except that the connection to this element is brought out at the top of the bulb. The screen grid is interposed between the cylindrical plate and the control grid, completely surrounding the plate. The plate is also cylindrical, but larger in diameter than the plate in the type CX199 tube.

The construction of the tube is very rugged, perhaps even more so than that of the ordinary tube.

This tube has been designed especially as a radio frequency amplifier, although it can be operated as an audio voltage amplifier as well. As a radio frequency amplifier, it is possible to obtain a very high amplification gain per tube, and with freedom from oscillation. The parasitic capacities between the elements within the tube are reduced to a negligible quantity; thus oscillations will not be created as long as there is no feed-back of energy due to associated wiring and apparatus.

The voltage amplification depends upon two factors: First, the mutual conductance of the tube, which determines the amplitude of the plate current changes, resulting from the signal voltage impressed upon the control grid. Second; the load impedance. The voltage across the output load is directly proportional to the load impedance in the plate circuit of the tube. This means that the amplification available is dependent, and directly proportional, to the impedance in the plate circuit of the tube. The resultant amplification is the product of the mutual conductance of the tube, which is about 300 micromhos under proper operating conditions, and the impedance in the plate circuit.

The most practical way to get a high impedance in the plate circuit for radio frequency amplification is by tuning a coil and condenser to the frequency which is to be amplified. This is shown in the circuit diagram accompanying this article. The impedance is highest when the circuit

(Continued on page 34)

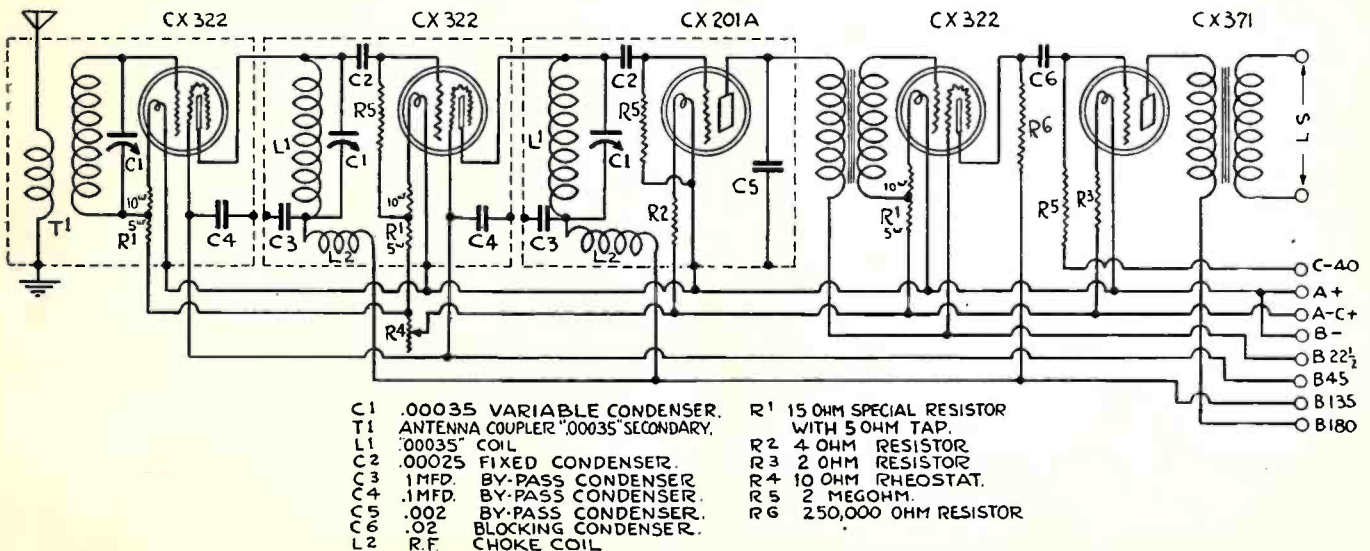



Certified Meloformers make three stages of ideal audio possible, and also render beautiful reproduction without slightest distortion on as high as four stages. Meloformers can be used for audio in any circuit, as well as those described on this page, etc. Specifications:—Mfr.; Robertson-Davis Co., Inc., Chicago; H., 2 1/4" O. A.; Base, 2" Sq.; Top, 1 3/4" Dia.

The Famous ROBERTSON-DAVIS **HOT**

GIVES 200,000,000 AMPLIFICATION

The ease with which you can receive distant stations with the famous Robertson-Davis HOT SPOT Fourteen Receiver is at once apparent from the results of our official laboratory test which proved that the radio frequency signal picked up by the loop on any HOT SPOT RECEIVER is actually amplified 201,550,000 times after it passes through the eleven Melocoupler Radio Frequency Transformers and three Meloformer Audio Frequency Transformers into the room from the loud-speaker.

See the illustrated editorial in the **BLUE**

None More Satisfactory

than

Cle-Ra-Tone Sockets

for the

"Hot Spot" 14



SPRING SUPPORTED
SHOCK ABSORBING

Benjamin Cle-Ra-Tone Sockets are positively the greatest contribution to the non-noisy operation of a set. Anti-microphonic. Stop tube noises. The tube "floats" on four perfectly balanced springs which absorb all jars and shocks. With knurled nuts for binding post connections or handy lugs for soldering. One-piece tube to terminal connection, eliminating high resistance joints.

At Your Radio Dealers

BENJAMIN ELECTRIC MFG. CO.
120-128 S. Sangamon Street
Chicago

247 W. 17th St.
New York

448 Bryant St.
San Francisco



THE SEASON'S CHAMPIONSHIP RECEIVER EASY TO BUILD—BEAUTIFUL PANEL & CHASSIS

ANY one with an inclination and interest in radio will find the Robertson-Davis HOT SPOT Fourteen Receiver easy to build from the illustrated article and Blue Print Plans printed in the editorial section of this issue of Radio Age. This Championship Receiver comes to you with a reputation of performance that agrees with what you are looking for. 14 Tubes. No Oscillator Repeats. Only 2 Tuning Controls. No Receiver Harmonics. Razor Edge Selectivity. Real Single Point Reception. A Beautiful Panel and Chassis.

PERFECT RECEPTION—DX OR LOCAL

The HOT SPOT Fourteen is simple and easy to operate. Brings in DX clear and loud through local interference—cross country on any night.

Sept. 16, 1927—JAS. H. BRADSHAW, 706 N. Kedzie Ave., Chicago, writes: "Gentlemen:—I can get distant stations any night and with local volume. Local stations tune out at 1/2 point of dials, and that is just what Chicago needs. I have had my "HOT SPOT" operating a month now and pulling in most every station in the country under the most unfavorable atmospheric conditions possible, as you well know the hot weather we have been having."

Similar reports reach us daily from all over the country. Copies of actual letters gladly sent on request.

YOU DON'T NEED A SILENT NIGHT TO
GET PERFECT DISTANCE RECEPTION
WITH *The Famous* HOT SPOT FOURTEEN

For Best Results With the

HOT SPOT "14"

Use Only the

HAMMERLUND

"Midline"

CONDENSER

and the

"HAMMERLUND, JR."

Midget

CONDENSER

Specified by the Designer

HAMMERLUND MANUFACTURING CO.

424-438 W. 33rd St., New York

For Better Radio
Hammarlund
PRECISION
PRODUCTS

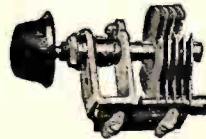

Photo above shows John H. Hartley of Brooklyn with his 1927-28 Prize-winning world's International Championship Hot Spot Fourteen Receiver.

SPOT FOURTEEN Championship Receiver

GAIN FROM LOOP TO LOUD-SPEAKER

John Harrison Hartley of Brooklyn won the 1927-28 World's International Championship for set building with a Robertson-Davis HOT SPOT Fourteen Receiver at the Radio World's Fair in New York. You will find him, his prize-winning receiver and trophy cups in the photograph below. The secret of the success of this famous circuit is the perfect construction and fundamentally correct hook-up of the Certified Robertson-Davis Melocouplers and Melocouplers illustrated here.

PRINT section of this issue of Radio Age



Certified Melocouplers are guaranteed radio frequency transformers for specific service in high-powered Fourteen and Eleven Tube Circuits. Each built with an air-core, peaked, wound and tested at the same point of efficiency; making kits unnecessary. Specifications—Mfr.; Robertson Davis Co., Inc., Chicago; H., 2 1/4" O. A.; Base, 2" Sq.; Top, 1 1/4" Dia.

For best results in your Hot Spot Fourteen, stick to the parts originally specified.



903-K
3 ohm Switch Rheo.

Yaxley parts specified are:

- 1 Yaxley 3 Ohm Switching Rheostat, No. 903K...\$1.75
- 1 Yaxley 4 Ohm Fixed Resistance, No. 804..... .15
- 1 Yaxley 3 Ohm Semi-Fixed Resistance with double Arm, No. 503DA..... .50
- 1 Yaxley 6 Ohm Semi-Fixed Resistance with double Arm, No. 506DA..... .50
- 1 Yaxley 200 Ohm Potentiometer, No. 200..... 1.75
- 1 Yaxley Cable Connector Plug, No. 669..... 3.25

YAXLEY MFG. CO.

9 So. Clinton St.
CHICAGO



Pattern No. 135-B

JEWELL Instruments

The selection of the highest quality radio parts for the Hot Spot Fourteen naturally includes Jewell instruments. Their use permits that exactness in radio control that makes the Hot Spot Fourteen stand forth as a most selective and powerful receiver.

Both instruments are of the same size and style of case and have a fine D'Arsonval moving coil movement. The Pattern No. 135-B, illustrated, has a double scale 0-7.5-150 volts and a handy push button switch for shifting from the low to the high range. The low range checks filament voltage—the high scale checks plate voltage. The Pattern No. 135 0-100 Milliammeter is placed in the plate circuit and used with the Pattern No. 135-B gives a real comprehensive indication of the set operating condition.

THE FAMOUS HOT SPOT FOURTEEN

Another Melo-Heald Design.



A super with actual single point reception

No Receiver Harmonics.
Razor Edge Selectivity.

No Repeats—It Registers at
One Point like a Thermometer.

14 Tubes—8 Stages of Intermediate—
3 Stages of Audio. 2 Tuning Controls.

This newest and unusually successful achievement in radio reception uses the same mixing system that made the Robertson-Davis MELO-HEALD Eleven Circuit famous. Each Intermediate Transformer is designed specifically for its position. Quickly built and easy to operate. If you want and can afford the best that radio reception offers, build a HOT SPOT Fourteen Receiver.

See Your Dealer or Jobber

ROBERTSON-DAVIS COMPANY, INCORPORATED
(Engineers & Manufacturers of Electrical Windings)
412 ORLEANS ST. Dept. RA-12 CHICAGO, U. S. A.

See Spring 1927 Issue Citizens' Radio Call Book for Details of the famous MELO-HEALD ELEVEN RECEIVER

FILL IN AND MAIL TODAY FOR ADDITIONAL FREE PLANS TO CONSTRUCT RECEIVER
 ROBERTSON-DAVIS COMPANY, Inc., 412 Orleans St., Chicago, U.S.A.

Gentlemen: Without charge or obligation, please send me further Plans and Specifications for construction of receiver checked below, and described in Radio Age. Also, send further particulars regarding Certified Melocouplers and Melocouplers manufactured by you and used in construction of the set. (Check Receiver you are interested in.)

I am interested in The Famous HOT SPOT Fourteen.

I am interested in The Famous Melo-Heald Eleven.

Name _____ Address _____ City _____ (Write or print clearly)

RA-12

Andrae Expands

Effective Nov. 1, 1927, the wholesale electrical and radio business of the Waterloo Electrical Supply Co., 303 West Fourth St., Waterloo, Iowa, was taken over by Julius Andrae & Sons Co., and the concern will hereafter be operated as a Branch of Julius Andrae & Sons Co., Milwaukee, Wis.

A Quadrode Record

Radio Age,
500 N. Dearborn St.,
Chicago.
Gentlemen:

I am sending you herewith a list of stations received on the "Radio Age Quadrode Super-heterodyne."

Station	Location	Antenna Condenser	Oscillator Condenser	Wave Length
WHO	Des Moines	93	97	535.4
KYW	Chicago	92	95	526.
WOW	Omaha	87	89	508.2
WFAA	Dallas	86	88	499.7
WBAP	Ft. Worth	86	88	499.7
WEAF	New York	84	85½	491.5
WCFL	Chicago	83	84	483.6
WSUI	Iowa City	81	82	475.9
KFI	Los Angeles	79½	80½	468.5
WRC	Washington	79	80	468.5
KRLD	Dallas	78	78½	461.3
WJZ	Brook Bound	77	77	454.3
WMAQ-WQJ	Chicago	75	75	447.5
WJR	Detroit	74	73½	440.9
WLW	Cincinnati	71	71	428.3
WOS	Jefferson City	69	69	422.3
WIBO	Chicago	68½	68½	416.4
WHAZ	Troy	68	68	
WTAM	Cleveland	65	65	399.8
KWKH	Shreveport	64	64	394.5
WJBT	Chicago	62	62	389.4
KGO	Oakland	62	61	384.4
CKY	Winnipeg	61	60	384.4
WJJD-WEBH	Chicago	58	57	365.6
WSAI	Cincinnati	56	56	361.2
KFWB	Hollywood	55	55	361.2
CHIC	Toronto	55	55	356.9
WWJ	Detroit	54	54	352.7
WLS	Chicago	52½	52½	344.6
WCB D	Zion City	52	52	344.6
WSM	Nashville	51	51	340.7
KNX	Hollywood	51	50½	336.9
WHB	Kansas City	50	50	336.9
WBZA	Boston	50	50	333.1
KOA	Denver	48	48	352.9
WQAM	Miami	47	47	322.4
WGN-WLIB	Chicago	43½	43½	305.9
WTMJ	Milwaukee	41	41	293.9
WEO	Columbus	39	38	282.8
WPG	Atlantic City	38	36	272.6
WCMA	Culver	36	34½	258.5
WDAG	Amarillo	34½	33½	263
WJAZ	Chicago	33	33	263
WMBB	Chicago	32	30½	252
WDOD	Chattanooga	29	28½	245.8
WGES	Chicago	27½	27½	241.8
WGBF	Evansville	27	25	236.1
WTAD	Quincy	27	25	236.1
WJKS	Gary	25½	24½	232.4
WJAY	Cleveland	25	23	227.1
WWAE	Chicago	25	22½	227.1
WLAC	Nashville	24	22	225.4
WABQ	Philadelphia	24	22	223.7
WCRW	Chicago	24	21½	223.7
WOMT	Manitowoc	23	21	222.1
WCBS	Springfield, Ill.	22	20	209.7
"Old Glory Station"		21½	19½	
WSA	Springfield, Tenn.	20	18	
WEHS	Evanston	20	17½	215.7
WNBA	Forest Park	18	15	208.2
CKY	Winnipeg	13½	8½	
Amateur (Voice)			10	
Texas Amateur Calling (Voice)		13	8	

VOLTRON TUBES

The "Heart" of the Quadrode

The Voltron Quadrode is the only tube of its kind on the market. With two grids and a common plate the single Voltron replaces what would ordinarily be the first detector and oscillator. The merits of this principle are proven—it makes a most startling advance in tubes and opens possibilities in receiver design never before realized. It makes seven tubes do the work of eight—it makes for increased efficiency in any super circuit.

Complete Quadrode Kits

A complete tube set exactly as specified for the Quadrode is neatly packed in kit form and may be purchased from your dealer. The tubes included in the Quadrode kit are:

- 1—Voltron Quadrode tube.....\$ 4.50
 - 1—Vitrol 171 power amplifier..... 4.50
 - 5—Voltron super-sensitive 201A amplifiers \$1.25..... 6.25
- \$15.25**

Voltron tubes are available in all standard types, Oxide filament, 210 super power amplifiers, 216B high power rectifier. Voltron A. C. tubes, types 226 and 227, are guaranteed to give you results that are superior to the battery tubes that you are now using in your set.

Although Voltron tubes are better—standard prices prevail.

K & H ELECTRICAL CORP.
68 Springfield Ave., Newark, N. J.

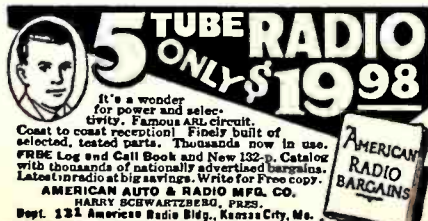

5 TUBE RADIO ONLY \$19.98

It's a wonder for power and selectivity. Famous ARS circuit. Coast to coast reception. Finely built of selected, tested parts. Thousands now in use. FREE Log and Call Book and New 132-p. Catalog with thousands of nationally advertised bargains. Latest radio at big savings. Write for Free copy.

AMERICAN AUTO & RADIO MFG. CO.
HARRY SCHWARTZBERG, PRES.
Dept. 124 American Radio Bldg., Kansas City, Mo.

The stations received were all on loud speaker (Newcombe-Hawley horn and New Erla unit) and the tone quality was excellent. I have built radio sets for my own amusement for the past six years. It has been some time since I have sat down

(Continued on page 36)



The Most Remarkable Receiver Ever Developed

We Could Charge More—But a Better Transformer Can't Be Made

Imitated everywhere—never equalled—the S-M 220 audio transformer stands out today as the finest for audio amplification that money can buy just as it did when introduced a year and a half ago. The 220 has been copied in one or more of its characteristics by every high-grade transformer put on the market since then—in the rising low note or in 5000 cycle cut-off, features first offered by S-M. That's proof that the principles the 220 introduced are right—that the market is still trying to catch up with the leader.

Don't be misled by exaggerated claims—for it takes plenty of core and wire to make a good transformer. The 220 has from 25 to 50 per cent more steel and copper in its construction than any other transformer on the market. That alone means the high primary impedance through which real bass note amplification is made possible.

That's why S-M 220's and 221's are specified in more popular receiver designs—why they have outsold every other transformer in their price field. That's why they're sold on an unconditional money-back guarantee to give better quality than any other audio amplifying device available.

We could charge from 25 to 50 per cent more than we do, but at no price can you get a better transformer. The 220 audio is \$8.00, and the 221 output is \$7.50. They are priced low, but, you can't buy a better audio coupler for there are none finer.

The New 240 Audios



We can't make the 220's cheaper but if you desire a transformer somewhat lower in price, taking up a little less room, and with a little less core and wire, the new 240 audio and 241 output transformers are available—superior to most other transformers and far and away ahead of anything in their price

field. They have the same general characteristics as the famous 220's and 221's, are the second largest A. F. transformers on the market and provide slightly less accentuation of frequencies below 80 cycles. They have the same 5000 cycle cut-off for which 220's are famous, eliminating the objectionable whistles and heterodyne squeals of congested broadcasting. The 240 audio sells for \$6.00 and the 241 output is \$5.00. Hard to beat at any price, they are impossible to equal at these prices. And—you can bring your old set up to the minute using them—they're small enough to fit in most anywhere.

We can't tell you here all about the new S-M developments. If you will send us 10c we will give you more authentic information about Shielded Grid receivers, A. C. operation, real audio amplification, how to use a 210 tube in your set and phonograph amplification, than you can hope to read in a week (blueprints and building instructions are 25c per set).

Silver-Marshall, Inc.

850-B West Jackson Blvd.

Chicago, Ill.

No matter what you might do—no matter what other receiver you might buy—the new Shielded Grid Shielded Six will literally walk rings around it from every and all standpoints of performance. This is a broad statement, but it does not begin to tell the whole story.

Operating on a loop in a steel apartment hotel in the heart of Chicago it will bring in KFI with WMAQ and WCFL going at full blast within two miles of the receiver, any night in the week. Practically all signals come in with such tremendous force that the volume control must be turned down. A new station will be found at almost every division of the two tuning dials. Powerful near-by locals come in on one point only and do not cause "repeats" or harmonics and never spread more than from two to four dial degrees. The Shielded Grid Sixes are even better than super-heterodynes for they go right down to the noise level, do not repeat on the dial and gives distance reception absolutely unbeaten by any other radio receiver.

The Shielded Grid Shielded Six is made in two models, the 630-SG for short antenna operation and the generally preferred 630-LSG for loop operation. The sensitivity of both models is tremendous—simply by placing a finger on the antenna post of 630-SG set, stations 1000 to 2000 miles away will come in with loud speaker volume! With a loop on the 630-LSG (or with a 20 foot antenna on the 630-SG) you literally have the whole country at your fireside, coast to coast regularly—not once in a while.

The Shielded Grid Shielded Six receivers will—from every standpoint—out-perform anything on the market and at the same time give you a tonal beauty that is not to be excelled. These are facts that you can prove to your own satisfaction. Build the 630-LSG or the 630-SG and if they will not out-perform any set you've ever listened to—if you're not more than satisfied—return the parts where you bought them and get your money back. The 630-SG kit for antenna use is \$97.00 and the 630-LSG for loop operation is \$91.50. Both sold under the unqualified guarantee to out-perform anything that the market offers.



The Famous 440 Time Amplifier

With a greater degree of selectivity, with a greater amplification factor—the 440 Jewelers Time Signal Amplifier offers possibilities never before realized in long wave amplifier construction. It is more accurate—with a finer degree of calibration—than any long wave amplifier that may be built from standard parts today. It's so good that it simply can't be beaten—with any combination of individual parts or anything else. It is housed in a copper and brass catacomb which completely and individually shields the three radio frequency and detector stages. The 440 Time Signal Amplifier is tremendously popular already, for thousands have been sold this season, simply because it's the best long wave amplifier ever developed. It is tuned exactly to 112 K. C., the 2677 meter wavelength of the Naval Observatory station at Arlington (NAA). Price \$35.00.

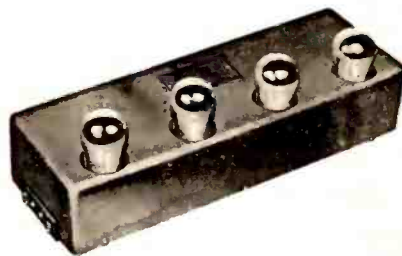

Silver-Marshall, Inc.
850-B West Jackson Blvd., Chicago

Please send me all data on the new Shielded Grid Shielded Six, the 440 Time Amplifier, real audio amplifiers and the new developments on A. C. operation for which I enclose 10c postage. Also: Blueprints and instructions for 630 Shielded Grid Sixes.....25c
 Universal all wave tuner.....25c

Name.....

Address.....

New Infradyne With Amplifier

By ALEXANDER MAXWELL

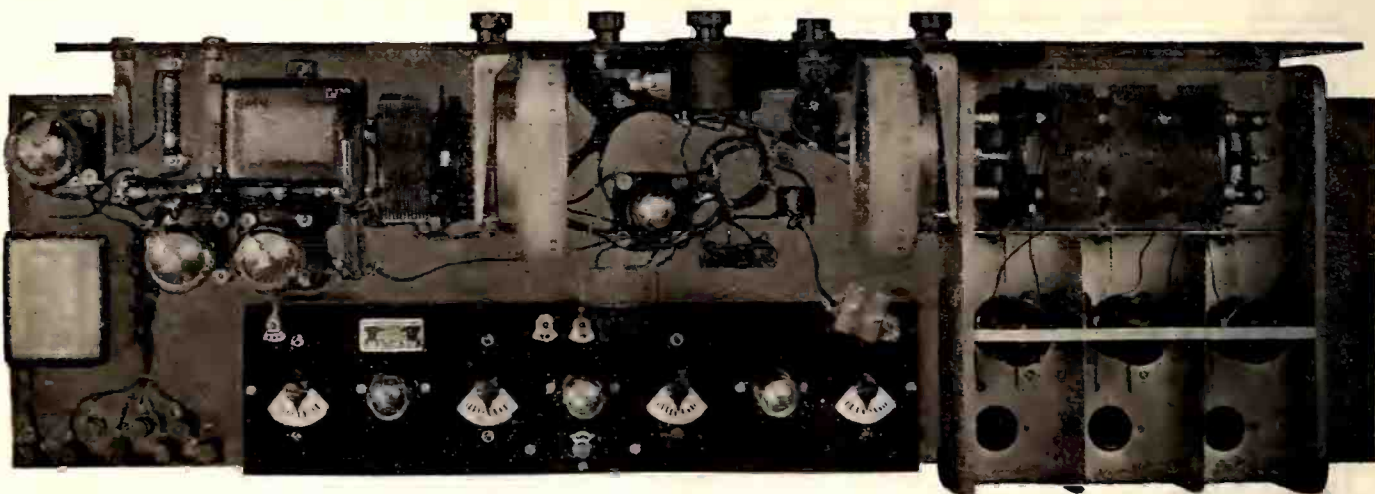

Top view of the 1928 Infradyne with new amplifier

IT HAS been nearly three years since the Remler Infradyne first made its bow, and because it is steadily increasing in favor the manufacturers are bending every effort to develop further refinements.

Minor improvements have been made from time to time, but now a major improvement has been released, an enclosed New Style 710 Radio Frequency Amplifier. This unit is similar to the one furnished with the Infradyne Kit, the only difference being it employs a bias on the mixer tube instead of a leak and condenser, and therefore requires an additional terminal.

We will go more into detail concerning the amplifier itself presently, but right now we desire to state that this article is written primarily for the man who already has an Infradyne of his own construction and desires to bring it up to date. If the reader is contemplating building the entire outfit from the ground up we advise constructing the Infradyne Kit, as described in these pages of the October number. If you do not have the October RADIO AGE it will be supplied upon receipt of thirty cents, post paid.

We take it for granted that the prospective remodeler has his set already mounted on panel and baseboard, and the parts wired at least somewhere near the specifications given at the time his particular model was released.

If so, the baseboard may be used as it

is. If not, then all the parts must be removed and regrouped. If time is no object it will be advantageous to remove the subpanel entirely and replace it with one of bakelite, putting all the wiring on the under side. There are so many wires in the Infradyne, especially after the change-over switch has been added, the finished set is likely to look like the wrong side of a telephone exchange unless care is used in placing the wires.

Remler recommends using the bunched cable system, which we heartily second. The smaller wires are every bit as satisfactory as the heavy, unwieldy bus, and if a different colored casing is used for each circuit it will make wiring and tracing very simple.

All of the present radio frequency amplifier must be dispensed with. Other instruments are left as they were, and those in the enclosed box must be purchased in addition.

Each wire in a receiver acts as a tiny aerial, and not only that, but each and every coil is a miniature substation, redistributing the energy received from the aerial. There are several methods of preventing this intercoupling, as it is called, the two in most common practice being shielding and the use of coils with a restricted field. To be on the safe side the 710 Amplifier is provided with both methods. Copper partitions are placed between all coils, and a continuous shell surrounds

the entire instrument. This shell and the partitions are grounded. Any stray oscillation that can penetrate this defense deserves a lot of credit. The coils deserve special mention for they are of unique construction. The secondary is split into two sections with their fields opposing, the grid and filament leads coming from the middle instead of the ends. The magnetic field extends just far enough to produce a coupling effect with the primary and right there it stops.

By consulting the wiring diagram of the 710 one will observe that the primary coil is tapped in four places and these leads go to the terminals as indicated. Tap number two is the grounded end of the secondary coil. The antenna compensator is furnished with the amplifier and is mounted on the panel between the drum and the meter. It consists of a tiny variometer and a three point switch, its purpose being to adapt the receiver to the particular aerial used, as well as providing additional selectivity in cutting out unwanted signals. It is a very important instrument, and it is rather delicate, so great care must be used, both in handling and in soldering the connections. Too much heat will melt other connections farther down the line, spoiling the entire effect and making a source of difficulty that is hard to locate. Use a bright iron and the minimum amount of solder, and do not apply the iron for more than five seconds at a time.

The Remler type 633 condenser is used in the amplifier. It is an elaboration of the original twin rotor condenser, maintaining all the desirable features and simplifying matters by the fact that all three condenser units are controlled in unison by a single knob.

It is practically impossible to make three variable condensers work in absolute harmony without a trimming device. In the case of the 633 these consist of small,



Back-Panel view of the New Infradyne

mica insulated compression condensers which are a part of the complete assembly and are not detachable. The three gangs are adjusted to resonance before leaving the factory, but if at any time one desires to change the adjustment it may be readily accomplished by means of a wooden screw driver furnished with the amplifier. Each of the three trimmng condensers is regulated by means of a screw with a slotted head. The wooden wedge is inserted in this slot and turned slightly. It is not advisable to make any adjustments on trimmers till the receiver is in working order, and then only when convinced beyond a shadow of a doubt the condensers do not aline properly.

In order to obtain the greatest coupling effect at a specified frequency the primary of the radio frequency transformer must be varied. This is in direct relation with the rotation of the condenser. By means of a system of levers and an ascending cam, the primaries of the three transformers are rotated as the condenser is advanced. This insures a maximum energy transfer at a given point, or to put it a bit more positively, the maximum energy transfer on all points within the range of the condenser.

The primary inductance may be varied by means of a three point switch on the first one, which is incorporated in the antenna compensator, and a two point switch on the other two. The adjustments of the latter are made permanently when the Infradyne is put in operation and need not be touched again. The first is varied whenever the occasion demands.

It is well known that a resistance inserted in the grid lead of a radio frequency receiver has a tendency to prevent oscillation. Therefore 500 ohms is provided for the first stage and 1000 ohms for the second, with short circuiting switches when not desired.



Panel view of the New 1928 Infradyne Receiver

It is difficult without vernier controls to build an amplifier which will function equally well in both metropolitan areas and the more rural districts. Remler has taken this into serious consideration and believes the 710 to be a solution to the difficulty. By adjusting the four switches and the antenna compensator the receiver may be made to tune sharp enough to cut through the superpower station in the next block, or it may be broadened till the out of town user will have no trouble in picking up stations. Using the compensator as a vernier one should be able to bring in very weak signals with sufficient audibility to be readily distinguished.

Now that we know just what the instrument is with which we are dealing we will go ahead and install it. Perhaps you noticed that in the panel layout no vertical dimensions were given. It is a bit difficult to do this in remodeling because all baseboards and subpanels are not the same thickness. To determine the correct height for mounting the condensers fasten the 710 amplifier to the baseboard and fasten the mounting for the drum dial, using the holes provided. Leave the control shaft off for the time being. Now screw the new panel onto the baseboard and with a soft pencil or a scratch awl carefully trace around inside the hole through which the control shaft would protrude.

This gives a point around which to work and all other measurements are made in direct relation. Now unscrew the panel and with a small drill make a hole in the center of the scribed circle, from the back side coming forward.

Take the left hand Rembler Template and paste it to the panel, making sure it is aligned correctly and the drilled hole is exactly under the center lines of the corresponding marking. Take the center punch and make an indentation for each hole. To locate the oscillator condenser it is only necessary to carry the guide lines over, and paste the right hand template in the correct place. The others are purely a matter of personal taste. We furnish a suggested panel layout which one will do well to follow.

Beginning from the left hand end the first knob controls the R. F. condenser, the second the antenna compensator, the third the R. F. rheostat, the one under it the Yaxley switch, the fourth the Infradyne rheostat, and the last the oscillator condenser. Certain parts have been done away with, namely the 50,000 ohm variable resistance. Volume is controlled solely by the ten ohm rheostat which controls the filaments of the first two tubes. The one mfd. fixed condenser is no longer used as one which performs its function is built into the R. F. amplifier.

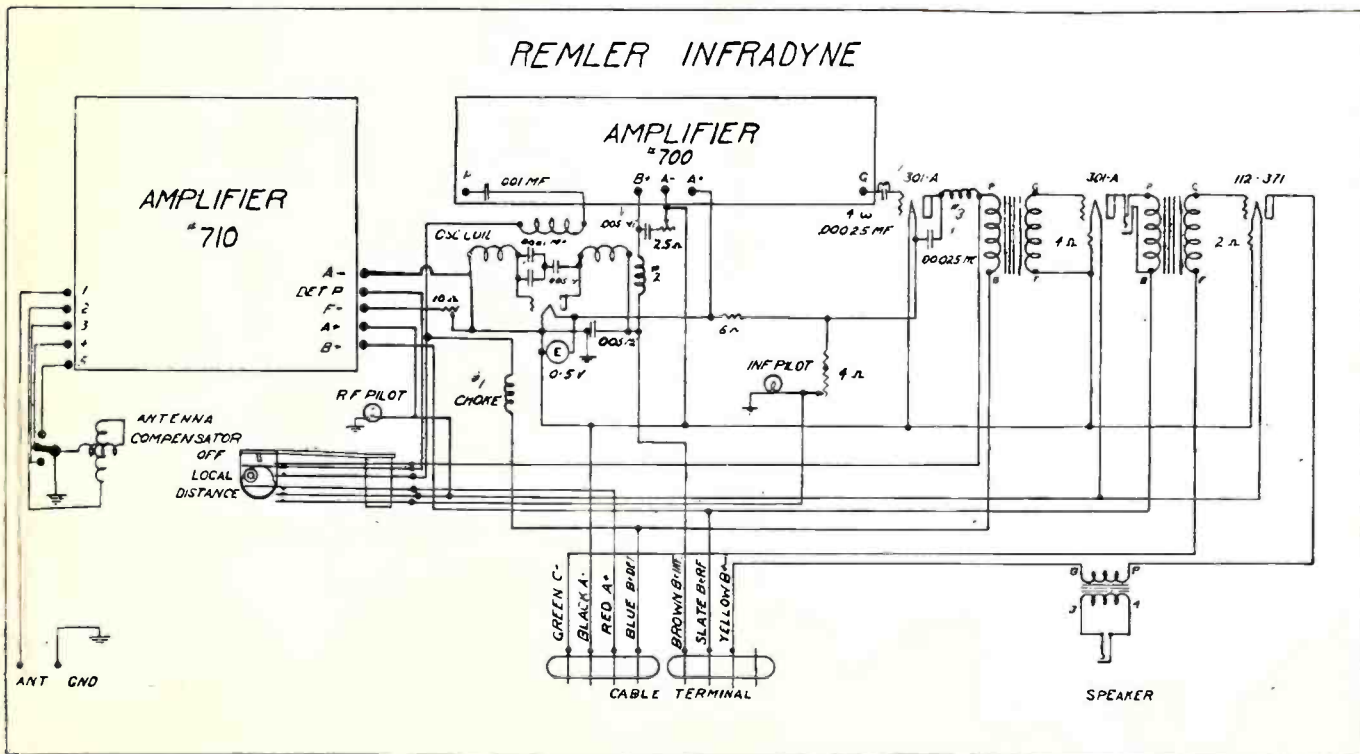

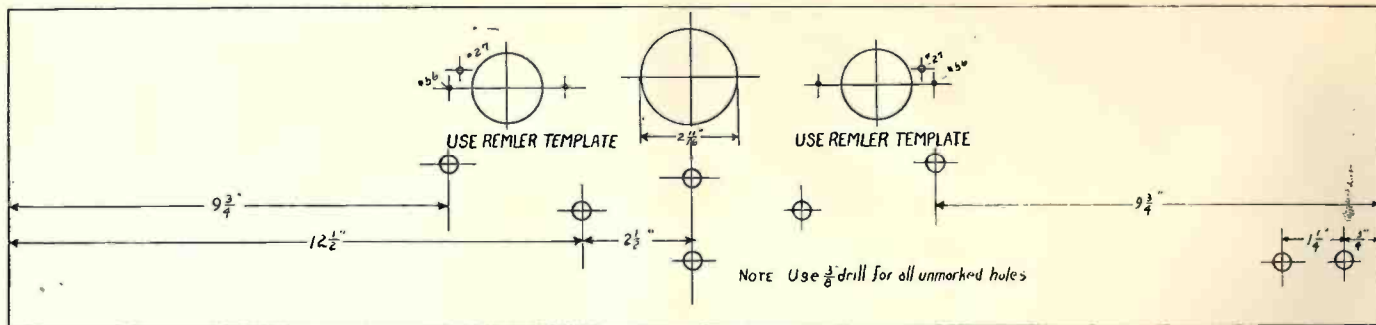

Panel template of the New Infradyne with amplifier

The two thirty ohm rheostats, one of which controlled the mixer tube and the other the 299 tubes have been replaced by a ten ohm rheostat, the one mentioned above, and another ten ohm rheostat used in conjunction with a six ohm fixed resistance. The Yaxley 10 switch has been replaced by a Yaxley 69 switch which provides an off position as well as changing from five to ten tube reception.

Wiring, as stated previously, may be left as it was, with suitable changes, or all replaced. If using the cable harness style keep the plate and grid leads free or trouble will develop. The old oscillator coupler may be used, or a Silver Marshall 110B substituted. It is not material as long as it contains the correct amount of wire.

It is most important that directions are followed in regard to connecting the three condensers in the oscillator circuit. The .0001 mfd. is shunted across the .00035 mfd. and a .0005 Sangamo hooked in series with the lead which goes to the plate. The purpose of the .0001 condenser is to alter the range so that the entire 360 degrees of the dial will be used instead of just half as in former models. In order to use the original coil in this manner two turns must be removed from the filament end of the grid coil. The coupler will then consist of an eight turn pickup coil, a twelve turn grid coil and a plate coil of fourteen turns.

New Parts Needed

- One panel 7x30x3/16 inches.
- One Remler 710 Amplifier complete with compensator.
- Two 10 ohm Frost Bakelite Deluxe Rheostats.
- One 2 to 10 ohm Frost Bakelite Deluxe Rheostat (used as sensitivity control)
- Two Remler 110 Drum Dials.
- One Yaxley 69 Switch.
- One Sangamo .0001 mfd. Fixed Condenser.
- One Thordarson output choke.

As soon as the new receiver is finished it must be carefully tested to make sure that all connections are correct and the B battery is not turned through the filament circuit. This may be determined by placing the tubes in the sockets and after connecting the A battery and proving that all tubes light correctly remove one wire and touch it to each of the B binding posts. If nothing happens then it is safe to connect the B batteries. Use plenty of patience and don't turn anything without making sure it needs turning. The Amplifier is already adjusted for best results with an aerial of from 50 to 150 feet, when received. These ad-

justments are for localities where conditions may be termed average, in regard to interference and electrical noises.

Switches One, Two, and Three are set on "non selective," switch Four on "selective." In localities where conditions are excellent switch number one is set on "selective," number two on "non selective," and numbers three and four on "selective." In locations where interference is bad different combinations may be tried, but be sure to make notations of the original settings so one may return to them at any time. Remember that this amplifier is designed to function in all localities, and for that reason is a bit more complicated than the average. Once it is out of resonance and the combination lost it is about as difficult to get back in working order as it is to pick the combination on the First National. It has been said that no matter how badly it is jammed up, turning something else will make it a little worse. This just as a word of precaution. It will work when received, and the best plan is to stay as close to the original scheme of adjustments as is possible.

When once in working order it should be left strictly alone, for nothing needs turning but the two tuning condensers and possibly the antenna compensator. The builder is probably so familiar with the adjustments of the Infradyne amplifier by this time no additional explanation is needed.

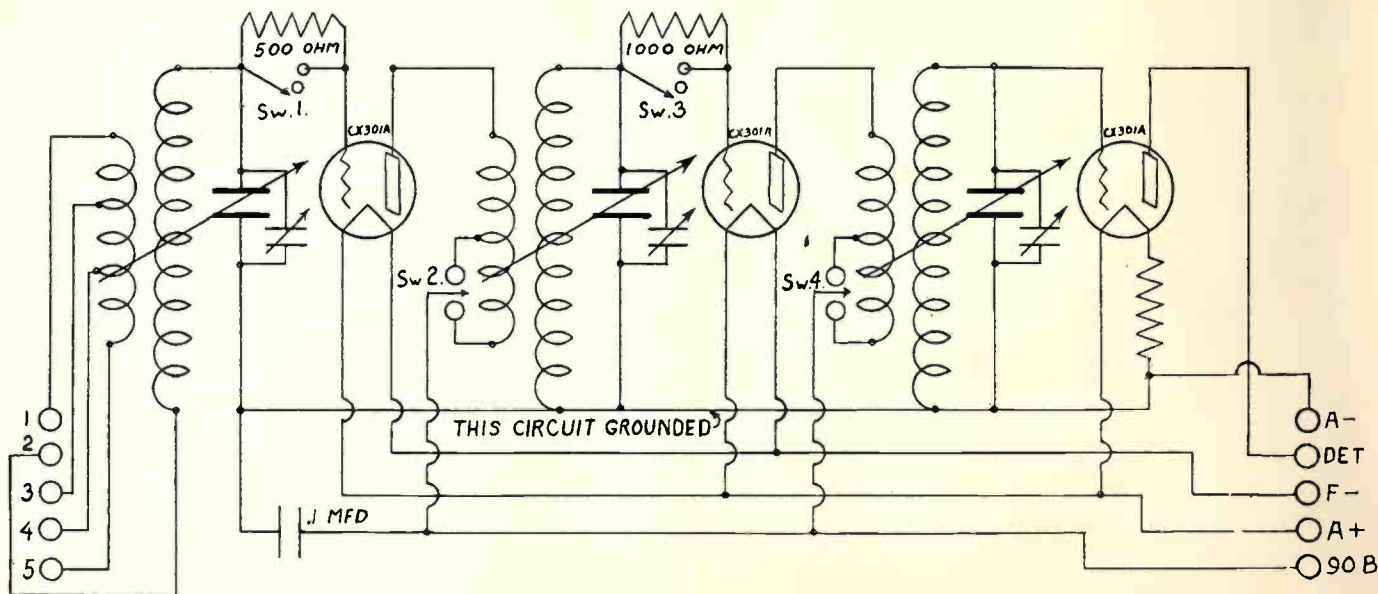

Schematic diagram of the new style amplifier for the 1928 Infradyne

The Amperite Adapter

By means of a new device just introduced, it becomes possible to modernize the old set without the use of tools or the performance of a major operation. In fact, not a single wire within the set is altered; not a thing is changed; not a single practical fact need be known about radio; yet, according to an announcement of the Radiale Company, the old set is instantly transformed into a modern set so far as efficient and simplified operation is concerned.

Briefly, the new device is the Amperite

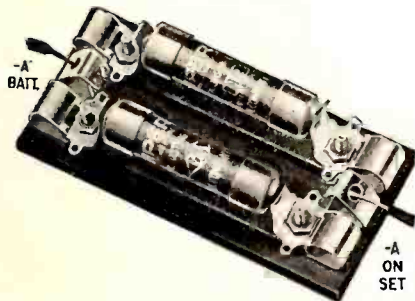

Adapter, comprising a base with clips to take two standard Amperite units complete, which are thereby connected in parallel so as to obtain their combined current-carrying capacity. The Amperite units are selected in order that the combination may provide the desired amperage for the group of tubes in the receiver thus controlled. Combinations are available for the precise control of any set from the simple three-tube layout without power tube, to the six-tube layout with power tube.

The Amperite Adapter may be mounted within the cabinet or at the rear or again near the external storage battery, according to preference. It is connected in the minus A lead, between storage battery and receiver. No tools are required. The wire ends clip into place. The only remaining step is to turn the rheostats of the set full on. If there are individual resistances or so-called ballasts, these are short circuited.

The set is now ready to operate with group control of the tube filaments, removing all guesswork as well as the extra manipulation of antiquated rheostats. The receiver is started or stopped by means of a single switch. The longest life is assured from the tubes, since they are operated at the correct filament temperature at all times.

The Hi-Q Power Unit

Truvolt Resistors, both fixed and variable, are enjoying the distinction of being exclusively recommended for the Hammarlund-Roberts Hi-Q Six B Power Supply Unit.

In order to meet the demand for Truvolts resulting from this recommendation, Electrad, Inc., manufacturers of Truvolts have designed a special resistance kit for use with Hi-Q.

The kit is in attractive box form and contains four special resistors, designated respectively Nos. 1, 2, 3 and 4. It is the company's intention to carry these designations without values or type numbers in all literature on the Hi-Q Power Unit, because the resistors so designated are

especially designed for use only with the Hi-Q.

In connection with this resistance kit, 25,000 Hi-Q booklets are being printed. These will carry full information on the Hi-Q Six B Power Supply Unit, together



with diagrams showing how the Truvolt Resistors in the Electrad Kit are to be incorporated.

The Kit containing these resistors lists at \$10.85.

Best Hookups—Thirty Cents Each!

We have laid aside a limited number of back issues of RADIO AGE for your use. Below are listed the best hookups and diagrams to be found in them. Select the ones you want and enclose 30 cents in stamps for each one desired

March, 1926

—How to Make a Wavemeter—Blueprint.

May, 1926

—Short Wave Transmitter—Blueprint.

—Simplifying Battery Charging.

—Protecting Your Inventions.

June, 1926

—Simple Crystal Set.

—Golden Rule Receiver—Blueprints.

August, 1926

—Receiver, Transmitter and Wavemeter.

—Beginners 200 mile Crystal Set.

—Changing to Single Control.

September, 1926

—How to Make a Grid Meter Driver.

—Short Wave Wavemeter.

—Power Amplifier for Quality (Blueprint)

October, 1926

—Crystal Control Low Power Transmitter (Blueprint.)

—Raytheon Design for A B C Elimination

—Nine Tube Super Brings Back Faith.

November, 1926

—Blueprints of the Henry-Lyford.

—Worlds Record Super With Large Tubes.

December, 1926

—Starting Radio with Crystal Set.

—Six Tube Shielded Receiver.

—Types of Rectifiers Discussed.

January, 1927

—Full Data on Worlds Record Set.

—Clough Super Design.

February, 1927

—Building the Hammarlund-Roberts.

—Making a 36 Inch Cone Speaker.

—Browning Drake Power Operated.

March, 1927

—Ideal Model Worlds Record Super.

—Building the Hammarlund-Roberts.

—Ridding Supers of Repeat Points.

—Loop and Four Tubes.

April, 1927

—Inexpensive B. Eliminator.

—One Spot Superhet.

May-June, 1927

—Complete Trouble Shooter for Supers.

—9 Tubes for Worlds Record Super.

July-August, 1927

—Building Vacuum Tube Voltmeter

—Low Power Crystal Control Transmitter.

September, 1927

—New A. C. Tubes in a Six-Tube R. F. Receiver (blue prints.)

October, 1927

—The Thompson Super-Seven.

—The 1928 Infradyne.

—New World's Record Super-Ten.

November, 1927

—Quadrode Super-Heterodyne.

—Radio Age Short Wave Receiver.

—1928 "Nine in Line."

—Airo-Seven

—Camfield Super-Ten

Radio Age, Inc., 500-510 N. Dearborn St., Chicago

9400 MILES

AUSTRALIA
PERTH

CHICAGO
U.S.A.

Build the 94000

You cannot possibly have any conception of the power of the Scott World's Record Super 10 until you spend a few minutes at its dials. Stations which you have heard in whispers on other sets, this receiver brings in with full, lifelike volume.

Read What Builders of This Set Say

"I can tune in nearly any station in Canada or any place in the United States consistently and at will, without interference from other stations."—Adrien Goulet, Montreal.

"The tone is beautiful and for DX reception no other Super I have built or heard can compare with it."—Dr. Louis Schulze, Chicago.

"Received 6. W. F. of Perth, Australia, June 25th with plenty of volume. Also have received J. O. C. K., Japan."—Virgil C. Zeis, Chicago.

"Tone is wonderful; volume enough to rattle the windows on DX like K. F. I., K. G. W., etc. The whole city is talking about it."—Albert K. Saylor, Monessen, Pa.

"I can tune in station K. F. I. every evening after 9:30 p. m. having no interference from local stations and with volume equal to local stations."—W. H. Hollister, Chicago.

VERIFIED RECORDS

- 8,375 Miles**
1. On March 17th World's Record for loop aerial reception—8,375 miles with Loud Speaker Volume.
- 9,400 Miles**
2. On June 25th Scott World's Record Super, located in Chicago received 6.W.F., PERTH, Australia, 9,400 miles away.
- 6,000 Miles**
3. On March 29th established new World's Record with reception of six foreign stations distant 6,000 miles or more.
- 6,000 Miles**
4. Established new World's Record for greatest number of broadcasting stations heard, located 6,000 or more miles away.
- 6,000 Miles**
5. Established new World's Record for most consistent reception of stations 6,000 miles or more distant—17 programmes from 19 different Foreign Stations, between December 27th and April 10th.

I GUARANTEE That the Set You Build Will Be Every Bit as Good as My Laboratory Model

The Scott World's Record Super 10—the set which eclipsed all previous radio performance standards was not a freak. Evidence of this—and proof that the set you build will do every bit as much as my laboratory model, is the fact that builders in all parts of the country report new and greater distance records every day. Every Scott World's Record Super 10 *should* be as good as my laboratory model, because the vital parts of each kit are all matched to the laboratory standard, and the plans I furnish are so complete, precise and so easily understood that error is practically impossible.

Build the Scott World's Record Super 10 and you will have a receiver which is years ahead of the present day com-



MR. E. H. SCOTT

mercial conception of radio. Build this set and be the proud owner of the very finest receiver in your community. Real Distance—real Selectivity—and the tonal advantages of high voltage power tube amplification will all be yours in a combination that no other receiver can even approximately approach. Mail the coupon right now for the whole story of the Scott World's Record Super 10.

The SCOTT WORLD'S

MADE AVAILABLE TO YOU THRU THE COOPERATION



REMLER 3-IN-LINE

Mechanically, and from the standpoint of efficiency in the handling of radio frequency currents, the REMLER 3-IN-LINE is the last word in gang condenser construction. Staggered connection of plates shields each stator section, one from the other. Balancing condensers are integral with the main unit and are easily and quickly adjusted.



REMLER DRUM DIAL

A precision product in every sense, reflecting in each detail of construction, the best in engineering and manufacturing practice. So designed that it is easily and quickly attached to any standard condenser, providing very smooth condenser control. Calibrated from 0 to 200 over the whole of its 360 degree surface. Handsome bronze panel face plate furnished with each unit.



BENJAMIN SOCKET

Spring cushioned, and hence completely shock-absorbing. Eliminates much tube noise and microphonic howl. Also greatly increases tube life by preventing jarring and consequent cracking of hot filaments. Made of genuine bakelite, and so fashioned that tube contacts are positive at all times.



Thordarson R-200 Audio

Every test reveals the undisputed supremacy of Thordarson amplifying transformers. The pair of R-200 Thordarson's which are called for in the specifications of the Scott World's Record Super 10, will correctly amplify throughout the whole musical range, every audible frequency which the broadcasting station itself is able to register. To the "tweet" of the highest flute note and the "zoom" of the cello, the Thordarson R-200 instantly responds. A Thordarson R-76 out-put transformer is also specified.

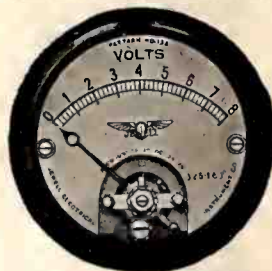

Jewell Voltmeter

In the careful selection of parts and accessories for the New World's Record Super 10, it is quite natural that a Jewell Pattern No. 135 Radio Voltmeter should be chosen. The black enameled case encloses a fine, D'Arsonval, moving coil type movement, having silvered parts and equipped with a zero adjuster. The scale is silver etched with black characters.

Please Mention Radio Age When Writing to Advertisers.

Mile Receiver!

The First Set to really Combine Extreme Distance ~ actual 10 Kilocycle Selectivity and absolute realism in Reproduction

The Scott World's Record Super 10 exceeds all present day standards of receiver performance. Positively nothing else is like it. Distance? The whole world seems to be on its dials! Volume? More than enough to fill a concert hall! Tone? Absolute realism—full, round, natural!

Beyond all doubt, this receiver has been the subject of more enthusiastic interest than any other ever built. It made its first bid for fame by establishing the world's long distance record for loop aerial reception—8357 miles. Since then it has plied up a host of records which would be unbelievable were it not for the authentic verifications at hand.

up to terrific volume by the amplification system of the Scott World's Record Super 10. And for much the same reason, this amazing receiver provides actual 10 Kilocycle selectivity no matter where it is located. The intermediate amplifier is peaked to pass only a 10 Kilocycle band, and the two tuned stages which feed it, pre-sharpen the signal to a point well within the 10 Kilocycle limit irrespective of the signal's strength at the time of input. Indeed, there has never before been such a receiver as the Scott World's Record 10—never before such power—never before such sensitivity. No wonder it is the favorite in districts where broadcasting is congested. No wonder it is the favorite with those who feel that nowhere in the world is there a station too far away to get!

Easy to Build in a Few Hours

The completeness of the Scott World's Record Super 10 is the main reason for its extreme efficiency. There is a great deal to this receiver. It embodies every known facility for conserving and using the bits of energy that other receivers waste. Complete though it is—complicated as it may appear, it nevertheless is so simple to build that the most inexperienced novice can put it together quickly—and with assurance of results beyond his fondest expectations.

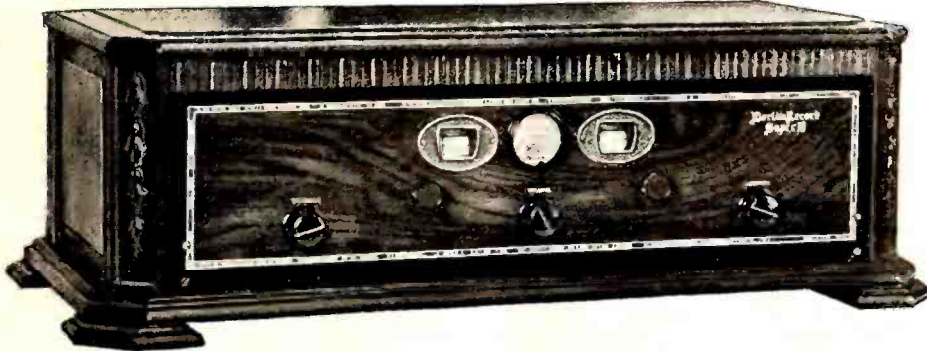

Super Power Audio

Most naturally nothing less capable than power audio amplification could handle the second detector output of the Scott World's Record Super 10. This was a foregone conclusion at the time this receiver was designed, and it was found that not only was a power tube necessary, but that a 210 power tube—and only a 210 would handle all that this receiver could feed to it. Result! Clear, pure undistorted volume limited only by the size and capability of the speaker used.

Two Stages of Tuned R. F. for Correctly Amplified Input and Additional Selectivity—and Three Stages of Long Wave R. F. for Power and Extreme Sensitivity

Most superheterodyne receivers depend solely upon the intermediate amplifier for radio frequency amplification. The Scott World's Record Super 10 has two stages of high-gain tuned radio frequency amplification preceding its intermediate amplifier. Hence, the signal fed into its intermediate amplifier, instead of being merely the weak impulse picked up by the loop, is as strong as the output signal of a highly efficient 5 tube tuned radio frequency set. The signal is then tremendously amplified in the long wave amplifier, the output of which, therefore, is most naturally many, many times greater than usually obtained from other types of superheterodyne receivers. Power? Signals heardly audible are built

FREE CIRCUIT DIAGRAM and Full Particulars

The far superior performance of the Scott World Record Super 10 is not happenstance. It is the direct result of coordinating many new and advanced engineering features in circuit and vital-part construction. Hence, the whole detailed story of the Scott World's Record Super 10 is one of the most enlightening radio stories ever written—and of vital, intense interest to you, whether you have a radio or not. Mail the coupon and we will send you absolutely FREE, complete circuit diagram and full constructional information. Mail the coupon Now. No Obligation.

RECORD SUPER 10

OF THESE LEADING PARTS MANUFACTURERS—

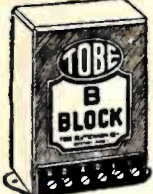

Tobe Condensers

The quality of by-pass condensers is of far more importance than the average set builder thinks. Too often, troubles which the builder cannot locate are to be found in the by-pass condensers. Hence, to insure year after year of quiet, efficient condenser performance in the Scott World's Record Super 10, TOBE Condensers were specified. These condensers, being better designed and better made of better materials, are certain in their action.



Carter Rheostats

Chosen for their unmistakable quality, smooth operation and compactness. The Carter Rheostat is an engineering masterpiece. It fits snugly up against the panel. Its sliding arm moves so smoothly and its contact is so positive that filament temperature variation is accomplished without even the slightest suggestion of attendant noise. Air cooled.

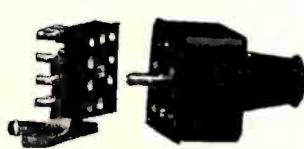

Jones Multi-Plug and Cord

The Jones 10 Contact Multi-Plug and Cord is, beyond all doubt, the finest way to connect batteries to a set, that has ever been devised. Fast—and quicker than binding posts to install; all the lead wires are in one compact, neat looking braid covered cable; contacts are always tight and all the batteries can be instantly disconnected from the set by merely pulling the plug. The cable and the unit which mounts onto the set are color coded to prevent mistakes, and the plug is keyed so it can go in the right way only.



Selectone Transformers

SCOTT Selectone Long Wave Transformers are, as laboratory tests reveal, the most efficient units of their type ever produced. They afford maximum selectivity and amplification and at the same time pass the full musical band, thereby assuring perfect tonal reproduction. Laboratory matched into kits and guaranteed to hold their ideal characteristics against time.

MAIL COUPON NOW

SCOTT TRANSFORMER CO.
7620-24 Eastlake Terrace
Chicago, Ill.

Send me FREE Circuit Diagram and full particulars of the Scott World's Record Super 10.

Name

Street

City

State

Please Mention Radio Age When Writing to Advertisers.

ANNOUNCING
THE
Radio Research
Service Company

55-57 E. Wacker Drive, Chicago
 Engineers

J. E. Badenius F. Freimann

Service to Manufacturers.
Service to the Publisher.
Service to the Public.

For the Manufacturer, we are prepared to render strictly confidential Service on radio and Electrical problems.

For the Publisher, we have a technical Service relative to latest developments in the engineering and manufacturing field.

For the Public, we have an engineer supervised Service and are in a position to solve your radio problems at a moderate price. If your receiver is not working satisfactorily get in touch with us.

Custom built radio sets of unrivaled range coupled with superlative tone quality, made to specifications.

AUTHORIZED RADIO AGE SERVICE LABORATORY

QUADRODE
BLUEPRINTS

Readers who desire blueprints of the Quadrode Superheterodyne Circuit may obtain them from Radio Age. They include:

Panel Templet—Exact Size
 Sub-panel Templet Exact Size
 Wiring Diagram
 Picture Diagram.

The price is 25 cents each or \$1.00 for set of four. Send stamps, money order or currency.

Address:

RADIO AGE
 500 North Dearborn Street

The Screen Grid Tube

(Continued from page 23)

is in resonance with the amplified frequency, but it is also dependent on circuit losses. The more efficient the tuned circuit the greater the impedance and consequently the amplification. Supposing the impedance were 100,000 ohms (at broadcast frequencies) multiplied by the mutual conductance of .0003 mhos would yield an amplification of 30 per stage. At lower frequencies it is possible to get a much higher impedance than it is at broadcast frequencies of 500 KC and higher. At frequencies from 50 to 100 KC it is possible to get amplification as high as 200 per stage. For instance, with a plate impedance of 500,000 ohms and a mutual conductance of .0003 mhos (300 micro-mhos) and amplification of 150 is obtained. It can readily be seen that the new tube also favors the superheterodyne methods of receiving, for at frequencies such as employed in intermediate frequency amplifiers the amplification that can be obtained is four or five times higher than with tuned r. f., per stage.

It should not be assumed that the above results can or will be arrived at by merely connecting up the proper instruments. In these calculations it was taken for granted that there was no tendency towards oscillations in the amplifier, however, under actual operating conditions we are confronted with a different situation. It is true that the effective inter-electrode capacity within the tube is reduced as low as .02 m.mfd. (a negligible value), but there will still be capacity, and inductive coupling between wires leading to the tube, coils, etc., and between adjacent stages. Unless the utmost care is taken in making these couplings ineffective towards producing oscillations there is little gain over our present methods with the usual tubes. Each stage must be isolated in a metal container of low r. f. resistance, and the grid and plate wires must be so arranged that the capacity between them is ineffective. A shield may have to be placed around the tube itself, or around the plate lead, or both, depending on the arrangement of parts, upon the frequency at which the amplifier is operating, and upon the amplification.

The circuit diagram is a suggestion for a five tube set using three CX322 tube, two as r. f. amplifiers, and one as an audio frequency amplifier, a CX301A is used for a detector and a CX371 power tube in the last stage. The broken lines indicate the shielding around each stage, this should be of copper or rather thick aluminum. Each stage must be well grounded. The coils should be highly efficient, for as explained before, the amplification depends on how good these coils are. They may be regular r. f. transformers with the primaries removed, and large enough to cover the whole wavelength band when tuned with .00035 condensers. Keep the coils well away from the shielding and the condensers. The .00025 condensers are used to keep the high plate voltage off the grids, and should therefore have a high d. c. resistance. The grid leaks are to carry the 1.5 volt bias which is provided by the

voltage drop across the ten ohm portion of the resistance in series with the filament, to the grids. The 3.3-volt tubes are operated in parallel with the five-volt tubes by connecting the fifteen ohm resistance in the negative side of the filament of each tube. The resistors should have a tap at the ten volt point to afford the proper bias for the grids. The choke coils L2 are of the ordinary r. f. type and used to prevent the r. f. from mixing in the battery circuit and instigating oscillations. When more than two stages of amplification are used even more elaborate filters are required to prevent feed-back from this source. The by-pass condensers of course aid in the same manner and are quite important. A gang condenser can be used to tune the circuits.

It will be noticed that in the audio stage using the CX-322, the screen grid bias is only 22½ volts; this compensates for the voltage drop in the load resistance of 250,000. When a higher voltage is used the screen grid voltage should be correspondingly increased. In this audio stage a voltage amplification of 35 may be easily gained, and with a perfectly uniform amplification of all frequencies. In the usual transformer coupled stage with the CX-301A tube the highest gain is about 22, with still retaining a fairly flat characteristic.

The tube can also be used as a detector, but resistance coupling must be used due to the very high plate impedance of the tube. This applies also to audio frequency stages—transformer coupling is no good here, at least not with the tube connected as a high amplification tube. It is however possible to connect the tube in such a manner to bring about a condition which makes possible the use of ordinary transformer coupling. This is known as the "space charge" effect. The "screen grid" is used as the control grid, and the inner grid is connected to the B battery.

The effect is to diminish the accumulation of electrons around the filament, which ordinarily prevent a greater portion of the electrons radiated from the filament to flow to the plate. The cloud of electrons in the proximity of the filament acts as a barrier and sends electrons back instead of allowing them to pass to their destination, the plate. The more electrons flowing to the plate the less is the plate potential required, hence, by bringing the positively charged grid into or near the field of the accumulated negative electrons they are disbanded and attracted to the plate—where all good electrons should go. The result is that it is possible to use a much lower plate voltage than we generally supply to our tubes.

There seem unlimited possibilities for experiments with these new tubes, and no doubt they will bring sleepless nights to many a fan because of the irresistible temptation to follow the many channels of experiments they will afford. There is nothing more gratifying than startlingly good results after hours of experimenting with a set, and also nothing more disappointing than having hours of work and dreaming result in nothing more than local stations and oscillations—the new screen grid tube will deal out both.

Standardization at Last!

Efforts of the Radio Manufacturers Association to bring about a single code of standards for the radio industry are at last achieving the desired results, according to an announcement from the RMA. The man who builds his own radio set, as well as the manufacturer, will be benefited by arrangements made toward the establishment of a single industry standard, to be determined with the aid of the American Engineering Standards Committee.

Although the Radio Manufacturers Association has a membership ten times that of any other manufacturer group in the radio field, a minority group has advanced a somewhat different code of standards. Both of these standards were drawn up in good faith, but by different groups, and accordingly reflected some differing opinions, bringing some confusion in the industry. Several attempts have been made to bring about a single set of standards.

The RMA announced last June that it would not publish any new standards until a very comprehensive plan could be made for the establishment of a single industry standard. A study of the situation showed that personal differences balked the single standard as long as it bore any trade association name. In recognition of this situation and as a practical expression of its sincere desire to bring about a single industry standard, the RMA arranged last September to drop the use of its name in connection with standardization, and to lend its efforts and influence toward the formation of a single industry standard, irrespective of what name any other and smaller group of manufacturers might desire to retain.

With the RMA taking this position and also desirous of securing valuable standardization suggestions from any expert source, a meeting was arranged by Dr. Agnew, Secretary of the American Engineering Standards Committee, and by Dr. Goldsmith, Secretary of the Sectional Committee on Radio of that association, with engineering representatives of the radio manufacturing interests to discuss their specific problems and differences. The result of this meeting, held recently (with the RMA represented by the Chairman of its Engineering Division, Mr. H. B. Richmond, of the General Radio Company, Cambridge, Mass.), was that a complete reconsideration is to be given to the existing codes of standards and their variances. An agreement was reached that all items on which there is no conflict shall be announced as radio industry standards. On items on which there is a disagreement the American Engineering Standards Committee will endeavor to analyze the situation, hear all evidence, and establish the industry standard with the understanding that any conflicting standards will be brought into harmony and agreement with the radio industry standards as rapidly as possible. The RMA will not publish any standards of its own, but will distribute to its members, and adhere to, the national radio standards as determined and approved by the American Engineering Standards Committee.

ARBORPHONE

A. C. Radio

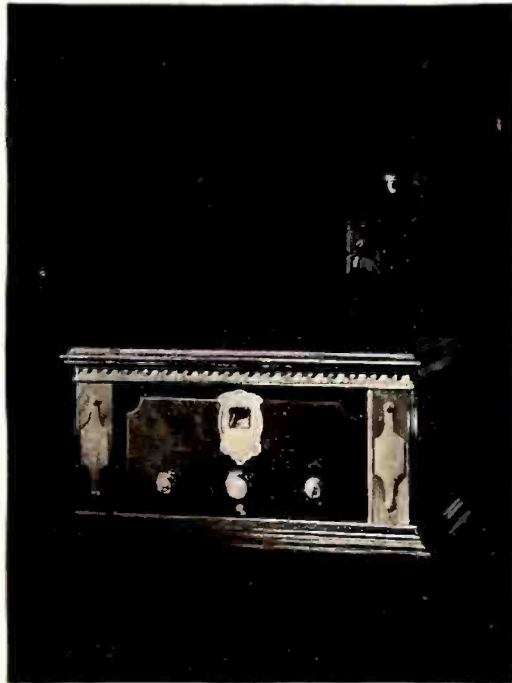

Table
Model
35

Operates
from
Lamp-
Socket

Seven
Tubes

No
Batteries

Cabinet beauty in keeping with the fine receiver it encloses

The Finest A. C. Radio in America

Loftin-White Circuit and other exclusive features

Uses Radiotron or Cunningham A. C. tubes—entirely self-contained—power units built-in—objectionable A. C. hum eliminated—A. C. volume control perfected—fully adjustable to variations in house current voltage—master control switch on front panel—exceptional tone quality and volume from push-and-pull power amplifier—equally good reception at every wave-length due to Loftin-White constant coupling—non-reactive plate circuit makes it entirely independent of tube capacity.

The perfected A. C. radio

For Sale by Better Radio Dealers

Write for 24 pp. booklet explaining the famous Loftin-White circuit as perfected in the Arborphone.

Arborphone Division
Consolidated Radio Corporation
Ann Arbor, Michigan



The beautiful
Console Model 352



The magnificent
Desk Console Model 353

Licensed under Radio Corporation of America, General Electric, Westinghouse Electric & Manufacturing Company, American Telephone & Telegraph Company, and Loftin-White patents.

Please Mention Radio Age When Writing to Advertisers.

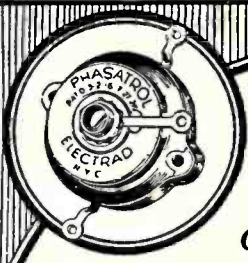

Licensed by Rider Radio Corporation
 Pat. Pending
 Pat'd 5-2-'16
 Pat'd 7-27-'26

Banish Oscillation Squeals

"PHASATROLS"
 Reg. U. S. Pat. off.

A True Balancing Device For all Radio Frequency Amplifiers.

PHASATROLS are Electrad's latest triumph! They stop oscillations and let distance come in smooth and clear. Leading radio engineers endorse them. Easily installed in any set—tuned, untuned or reflex. Price \$2.75.

At Good Dealers

Write for free Phasatrol book-up circular for many popular circuits.
 Dept. 62C 175 Varick St., New York, N. Y.

ELECTRAD

A Quadrode Record

(Continued from page 26)

and played "radio golf" and I certainly enjoyed tuning around and "seeing" who I would get next with the Quadrode. This set gets through and does not cut off the side bands. It is very sharp and requires careful tuning. Although my list shows only one-half numbers it will be found that about three stations can be obtained in some spots between points on the dials.

If the "radio modifier" or potentiometer is turned on full and the "audio modifier" only slightly some of the out of town stations like WWJ, Detroit, and WLW, Cincinnati, come in with the same volume as local stations. I would advise persons building the set to take a few hours to learn how to use that set before making a log. Don't forget to put a piece of wire between the last two binding posts if using an antenna. Also, loosen the coupler if locals are too broad. A resetting of the antenna condenser may be necessary if coupler is loosened while adjusting to a station.

I received station KFKB, Milford, Kansas, at about 8:30 a. m. Sunday morning, November 20th, at distance of approximately 500 miles. Below 10 on the oscillator dial I heard amateurs talking. Another odd one was station CKY on about 192 meters or about one-half of their regular wave length. I don't find this listing on any published lists but reception was obtained on Tuesday night, November 22nd. They were staging the "Frolics."

None of the receiving was after 12 at night when it is easier to get the western coast stations. All the locals were on and I worked at it for only an hour or two on the nights of November 21st and 23rd, inclusive.

You will no doubt note that some of the stations are out of their proper place on the oscillator dial. However, they were received as noted. These differences are in the wave length and are as follows:

WCMA Culver, WCBS Springfield, Ill., and WEHS Evanston, WSA Springfield, Tenn., is not listed on any list that I have. WSIX Springfield is listed but I received WSA Springfield, Tenn. All of these stations were received with an antenna. I am going to try a loop.

Yours very truly,
J. LOUIS ROBERTS.

The Quadrode Super-Heterodyne

(Continued from page 6)

such a device the power tube can be removed from the set and operated in the "B" supply unit, where provisions are made for it. The filament is operated from the five volt a. c. winding, thus making it practical to use a "A" power unit having only a two ampere capacity.

An outside antenna consisting of a single wire from 60 to 75 feet long (including the lead-in wire) will bring in the best DX, on the other hand the set is so powerful that fine performance can be obtained from a small loop antenna, or even a small indoor wire laid beneath the rugs, or around moulding.

QUADRODE BLUEPRINTS

Blueprints of this popular super-heterodyne, which was introduced by Radio Age in the November issue, can be had at 25 cents each or for \$1 the complete set of four. They are for panel template, sub-panel template, wiring diagram and picture diagram. Address Radio Age, 500 N. Dearborn St., Chicago.

HEADQUARTERS

for the
Shielded Grid Six—
Radio's Most Remarkable Receiver

The Lincoln Radio Corporation, manufacturers of the famous Lincoln Loops and Long 45 Tuners since the early days of broadcasting, are proud to offer you a radio set without a single apology or qualification for its performance. In the long history of Lincoln engineering dating from the infancy of broadcasting, Lincoln engineers have never before discovered any other receiver that they could so whole heartedly endorse and so unconditionally guaranteed.

The Silver-Marshall Shielded Grid Sixes, the very latest radio sets using the new Shielded Grid tubes have in the Lincoln Chicago Laboratories brought in East and West coast stations regularly on the speaker using either a loop, a twenty foot antenna, and in some cases, no antenna at all—all this with marvelous tone on any night in the week, with fifteen to thirty local stations operating!

Custom-Built to Order

Lincoln offers you immediate delivery on the regular S-M Shielded Grid Six kits, 630-SG for antenna operation at \$97.00 and 630-LSG for loop use at \$91.50. In the Lincoln Laboratories you can have these sets custom built, tested, and guaranteed at \$25.00 each, and furnished in beautiful Fritts walnut cabinets at \$22.00 additional.

Lincoln custom built Shielded Grid Sixes and S-M kits are unconditionally guaranteed to give better distance, selectivity and tone than any set you have ever heard or used, or your money cheerfully refunded.

To set builders a profitable agency plan is available selling Shielded Grid Sixes. Think what the agency for a set that you can guarantee to out-distance any other set made means to you! Lincoln can furnish you accessories—tubes, cabinets, speakers, kits, sets and all standard merchandise at a saving, and with the Lincoln Laboratory guarantee.

Lincoln Radio Corporation
 222 South Wood Street Chicago, Ill.

Lincoln Radio Corp.
 232 So. Wood St., Chicago

I am interested in your remarkable guaranteed Shielded Grid Sixes..... I am interested in your profitable agency plan.....

Name.....

Address.....

PATENTS

To the Man with an Idea

I offer a comprehensive, experienced efficient service for his prompt, legal protection and the development of his proposition.

Send sketch of model and description, for advice as to cost, search through prior United States patents, etc. Preliminary advice gladly furnished without charge.

My experience and familiarity with various arts frequently enable me to accurately advise clients as to probable patentability before they go to any expense.

Booklet of valuable information and form for properly disclosing your idea free on request. Write today.

RICHARD B. OWEN, Patent Lawyer
 81 Owen Bldg., Washington, D. C.
 41-M Park Row, N. Y. City



RADIO WHOLESALE

Write for my Big 1928 Radio Catalog—just off the press. Thousands of marvelous bargains in nationally advertised goods. All the LATEST IN RADIOS and equipment. Lowest wholesale prices. Agents Wanted.

FREE

It's a regular encyclopedia on Radio. All about trouble finding. **FREE Log and Call Book and Catalog.** Get your copy today. Send postcard now!

American Auto & Radio Mfg. Co.
 HARRY SCHWARTZBERG, PRES.
 Dept. 123 American Radio Bldg., Kansas City, Mo.

DEALERS NEW 1928 CATALOG

New Move by Independents

Co-operative research to perfect new radio circuits, as well as new inventions in radio tubes and other devices, will be inaugurated by the Radio Protective Association. This was decided upon at a convention in Cleveland, Wednesday and Thursday, December 7 and 8. As a basis for this program, leading members of the association have already offered to cross-license their valuable patent holdings with all other members of the organization. Plans for a general patent interchange—the first step in such cross-licensing to be taken in the industry—will therefore also be made as a result of the Cleveland meeting.

"The Cleveland meeting will mark a decisive step forward for the independent radio manufacturers of the United States," said Oswald F. Schuette, executive secretary at the Chicago headquarters in announcing the Cleveland convention, "So far we have carried on an offensive and defensive campaign against the Radio Corporation of America and its constituent companies, to prevent the Radio Trust from monopolizing the industry by destroying the independent manufacturers and dealers. This campaign has been an effective one.

"But now we intend to supplement it with a constructive campaign of scientific research and discovery for the joint benefit of our members. Here the independents, unhampered by license agreements, have a great advantage. By co-operation we hope to show the world some startling progress in the great untouched fields of radio development. Although the Radio Protective Association includes the most important of the independent manufacturers, it is by no means a closed organization. We shall be glad to welcome independent companies everywhere, large or small, and to give them an equal share in this opportunity for perfecting the radio art. By a system of cross-licensing the patents of our members as well as those to be perfected by joint laboratory, we are confident that we will be able to keep the independents in the forefront of radio progress."

Soft Pedal on New Laws

Additional state or municipal legislation against unusually large volume loud speakers causing local disturbances, such as those used for demonstration purposes outside radio stores should not be enacted in the opinion of the Legislative Committee, Radio Division National Electrical Manufacturers Association, which held its mid-winter meeting in Chicago.

It is believed by the members of the Committee, of which Dr. Alfred N. Goldsmith is Chairman, that such operation of loud speakers as may interfere with the comfort or the health of neighboring persons, can be controlled either as a public nuisance or under the authority of the local health officials. Where such devices become public nuisances, they ordinarily come under the classification of a disturbance of the peace and can be dealt with without additional legislation.

The Committee also considered the question: Should States or municipalities pass legislation specifically directed against a

A Sensational Success!

They are **Enthusiastic**

Being absolutely pleased with the Eliminator bought from you last June, it is really pleasure for me to order two more for some of my relatives. Find enclosed money order.—
Leopold O'Reilly, Montreal, Que.

Your Eliminator is certainly working fine. I have it hooked up to a 6-tube No. 20 Atwater Kent, and I get a better reception than I have had since I owned the set.—
John W. Jackson, Palmsville, O.

The Eliminator I purchased from you six months ago has given perfect satisfaction. I have it connected to a six-tube Columbia and get better results than I ever had with "B" batteries.—
Bernard V. Dugan, Lockport, N. Y.

I have one of your Eliminators purchased from you last winter. It has been in use constantly ever since and I want to say it has been perfect in every respect and cannot be beat by any other.—
Fred H. Kembel, Hastings, Neb.

You will be enthusiastic, too

Townsend "B" Socket Power

Approved and passed by the rigid laboratory tests of Popular Radio and Radio News

Over 25,000 sold the first 6 months

—Overwhelming evidence that VALUE is quick to be recognized and appreciated. Unsurpassed quality is built into the Townsend "B" Socket Power Unit with money saved by unified production methods and lower merchandising costs.

You get more—you pay far less—for the most remarkable value in Radio today. New thousands of Radio set owners are learning this daily by installing Townsend "B" Socket Power.

Sold on REAL GUARANTEE OF MONEY BACK IF NOT SATISFIED. Delivers up to 100 volts on any set, on DC. or AC.—any cycle. Full tone, clarity and volume.

SEND ORDER TODAY

Simply fill out the coupon and slip it into an envelope with only \$1.00 and mail at once. Your Townsend "B" Socket Power Unit will be sent promptly. Deposit only \$5.85 plus postage with the postman. Try out for 10 days—then if it does not do everything we say, return it to us and purchase price will be refunded.

TOWNSEND LABORATORIES
Dept 31
713 Townsend St., Chicago, Ill.



Attach Only \$1.00 to this Coupon

Complete \$6.85 \$1.00 Down Balance C.O.D.

Send for Literature

TOWNSEND LABORATORIES
713 Townsend St., Dept. 31 Chicago, Ill.
Gentlemen: Attached find \$1.00. Kindly send at once Townsend "B" Socket Power Unit, C.O.D. for \$5.85, plus postage, on guaranteed 10-day free trial.

Name _____
Address _____
City _____ State _____

COME IN AND HEAR THE
Long Air Column Dray Deepspeaker
at \$45 (in its own cabinet-table) performing on an 11 tube single dial—A.C. operated.

INFRADYNE
Free Consultation for Infradyne Builders

DRAY RADIO LAB.
6 E. Lake, Chicago 1266 Central

ALL
Popular Circuits

Set builders will find in the *New Directory of Kits* an itemized list of the parts used in all new circuits. Send 10 cents in stamps to cover mailing and handling for this new Kit Supplement.

Newark Electric Co.
223 W. Madison Street
CHICAGO :: ILLINOIS

Correct List of Broadcast Stations

Station	Location	Kilo-cycles	Meters	Power	Station	Location	Kilo-cycles	Meters	Power
KSD	St. Louis, Mo.	550	545	500	WQAO- WPAP	Cliffside, N. J.	760	394	500
KFUO	St. Louis, Mo.	550	545	1000	KTW	Seattle, Wash.	760	394	1000
WMAK	Lockport, N. Y.	550	545	750	KWSC	Pullman, Wash.	760	394	500
WPTF	Raleigh, N. C.	550	545	500	KWKH	Shreveport, La.	760	394	1000
WFAA	Dallas, Texas	550	545	500	KOB	State College, N. M.	760	394	5000-7500
WDAY	Fargo, N. D.	550	545	250	WBBM	Chicago, Ill.	770	389	5000
KFDY	Brookings, S. D.	550	545	500	WAAF	Chicago, Ill.	770	389	500
WCAC	Mansfield, Conn.	560	535	500	WJBT	Chicago, Ill.	770	389	500
WHO	Des Moines, Ia.	560	535	5000	WABI	Bangor, Me.	770	389	100
KFBK	Sacramento, Cal.	560	535	100	WQAM	Miami, Fla.	780	384	750
WTIC	Hartford, Conn.	560	535	500	WMBF	Miami Beach, Fla.	780	384	500
WNYC	New York City	570	526	500	KGO	Oakland, Cal.	780	384	5000
KFKX	Chicago, Ill.	570	526	2500	WBSO	Wellesley Hills, Mass.	780	384	100
KYW	Chicago, Ill.	570	526	2500	KTHS	Hot Springs, Ark.	780	384	1000
KMTR	Los Angeles, Cal.	570	526	500	WCAJ	Lincoln, Neb.	790	379	500
WMC	Memphis, Tenn.	580	517	500	WGY	Schenectady, N. Y.	790	379	5000
WWVA	Wheeling, W. Va.	580	517	250	KNRC	Santa Monica, Cal.	800	375	500
WFLA- WSUN	Clearwater, Fla.	580	517	750	WOC	Davenport, Ia.	800	375	1000
WTAG	Worcester, Mass.	580	517	250	WDAF	Kansas City, Mo.	810	370	1000
WEEI	Boston, Mass.	590	508	500	KHO	Spokane, Wash.	810	370	1000
WOW	Omaha, Neb.	590	508	1000	WMCA	Hoboken, N. J.	810	370	500
KLX	Oakland, Cal.	590	508	500	WLWL	New York City	810	370	1000
WBAP	Fort Worth, Texas	600	500	5000	WBEH	Chicago, Ill.	820	366	500
WOAI	San Antonio, Texas	600	500	5000	WJJD	Mooseheart, Ill.	820	366	1000
KGW	Portland, Ore.	610	491	1000	KMJ	Fresno, Cal.	820	366	50
WEAF	Bellmore, N. Y.	610	491	50000	WCSH	Portland, Maine	820	366	500
WJAR	Providence, R. I.	620	484	500	WSAI	Cincinnati, O.	830	361	5000
KFBU	Laramie, Wyoming	620	484	500	KFWB	Los Angeles, Cal.	830	361	500
WCFL	Chicago, Ill.	620	484	1500	WWJ	Detroit, Mich.	850	353	1000
WLTS	Chicago, Ill.	620	484	100	WEW	St. Louis, Mo.	850	353	1000
KUSD	Vermillion, S. D.	620	484	250	WOO	Philadelphia, Pa.	860	349	500
WEMC	Berrien Springs, Mich.	620	484	1000	WIP	Philadelphia, Pa.	860	349	500
WTAW	College Stat., Tex.	620	484	500	WGBS	Astoria, L. I. N. Y.	860	349	500
KFDM	Beaumont, Tex.	620	484	500	KVOO	Bristow, Okla.	860	349	1000
WSB	Atlanta, Ga.	630	476	1000	KJR	Seattle, Wash.	860	349	2500
WSUI	Iowa City, Ia.	630	476	500	KXA	Seattle, Wash.	860	349	500
WRC	Washington, D. C.	640	468	500	WLS	Chicago, Ill.	870	345	5000
KFI	Los Angeles, Cal.	640	468	5000	WCBD	Chicago, Ill.	870	345	5000
WCAE	Pittsburgh, Pa.	650	461	500	KWG	Stockton, Cal.	870	345	50
WNAC- WBIS	Boston, Mass.	650	461	500	KFQD	Anchorage, Alaska	870	345	100
KRLD	Dallas, Tex.	650	461	500	WAPI	Auburn, Ala.	880	341	1000
KFNF	Shenandoah, Ia.	650	461	2000	WJAX	Jacksonville, Fla.	880	341	1000
WRR	Dallas, Tex.	650	461	500	WHB	Kansas City, Mo.	880	341	500
KUOM	Missoula, Mont.	650	461	500	WQQ	Kansas City, Mo.	880	341	500
WJZ	Bound Brook, N. J.	660	454	30000	WSM	Nashville, Tenn.	890	337	5000
KFRG	San Francisco, Cal.	660	454	1000	KNX	Los Angeles, Calif.	890	337	500
WMAQ	Chicago, Ill.	670	447	1000	KFQB	Fort Worth, Tex.	900	333	1000
WQJ	Chicago, Ill.	670	447	500	WJAD	Waco, Tex.	900	333	500
KFOA	Seattle, Wash.	670	447	1000	WBZ	East Springfield, Mass.	900	333	15000
WJR- WCX	Pontiac, Mich.	680	441	5000	WBZA	Boston, Mass.	900	333	500
WIBG	Elkins Park, Pa.	680	441	50	KSAC	Manhattan, Kans.	900	333	500
KFSD	San Diego, Cal.	680	441	500	KFJM	Grand Forks, N. D.	900	333	100
WAAW	Omaha, Neb.	680	441	500	KSEI	Pocatello, Idaho	900	333	250
WLW	Harrison, O.	700	428	5000	WHA	Madison, Wis.	900	333	750
WLW	Cincinnati, O.	700	428	500	WLBL	Stevens Point, Wis.	900	333	1000-2000
WMAF	South Dartmouth, Mass.	700	428	500	WRNY	Catesville, N. Y.	920	326	500
WOR	Newark, N. J.	710	422	3500	WPCH	Hoboken, N. J.	920	326	500
KPO	San Francisco, Cal.	710	422	1000	KOA	Denver, Col.	920	326	2500-5000
WOS	Jefferson City, Mo.	710	422	500	WRHF	Washington, D. C.	930	322	150
WGN- WLIB	Chicago, Ill.	720	416	500	WHAS	Louisville	930	322	500
WLIB- WGN	Near Elgin, Ill.	720	416	15000	WKAQ	San Juan, Porto Rico	930	322	500
KHJ	Los Angeles, Cal.	720	416	500	KICK	Atlantic, Iowa	930	322	100
WLIT	Philadelphia, Pa.	740	405	500	WIAS	Ottumwa, Iowa	930	322	100
WFI	Philadelphia, Pa.	740	405	500	KOIN	Portland, Ore.	940	319	1000
WCCO	Minneapolis, Minn.	740	405	5000	KOIL	Council Bluffs, Iowa	940	319	5000
WEAR	Cleveland, O.	750	400	1000	KFAB	Lincoln, Nebr.	940	319	5000
WTAM	Cleveland, O.	750	400	3500-5000	KDKA	Pittsburgh, Pa.	950	316	50000
WSBT	South Bend, Ind.	750	400	500	KPSN	Pasadena, Cal.	950	316	1000
KMA	Shenandoah, Ia.	760	394	1000	WABC	Richmond Hill, N. Y.	970	309	2500
WHN	New York City	760	394	500	WBOQ	Richmond Hill, N. Y.	970	309	500
					KYA	San Francisco, Cal.	970	309	500
					KOMO	Seattle, Wash.	980	306	1000
					WHT	Chicago, Ill.	980	306	5000
					WIBO	Desplaines, Ill.	980	306	500

radiating receiver? In general, it was the sense of the group that States or municipalities should not legislate against a radiating receiver. Some reasons given were: That such receivers may be regarded as transmitters in miniature, and, therefore are under the regulatory power of the Federal Government, since reception of signals from outside the state would be interfered with. It was also considered that most manufacturers have voluntarily stopped production of such receivers, and public opinion will compel their ultimate abandonment; and that statutes and ordinances against disturbing the peace or maintaining a nuisance are in existence and are apparently adequate; and that municipal and State regulations, if enacted, would not be uniform and would result in much confusion.

The Committee held that receiving stations or sets should not require any license whatsoever, either Federal, State, or municipal, since the present system is well-established; and that there was no more justification for licensing a radio receiving set than for licensing electric phonographs, electric refrigerators or other household conveniences.

It was the unanimous opinion of the Committee that the regulation of radio transmission should be solely handled by the Federal Government, since radio communication is interstate and international in character. Local control of radio transmission would be tremendously complicated and non-uniform; and furthermore a uniform enactment is essential under the Constitution of the United States, since the Constitution gives to the Federal Government the control of interstate commerce.

The results of this study by the Legislative Committee were presented to the Radio Division membership at its mid-winter meeting held at the Edgewater Beach Hotel, Chicago, Ill.

"Tube Clause" Attacked

Immediate action by the Federal Trade Commission on the complaint against the "tube clause" in the Radio Corporation of America's license agreement should result from the commission's decision that the text to the clause, requiring licensees to equip their sets with Radio Corporation tubes, is to be investigated in a separate action instead of under the general anti-trust complaint against the corporation.

This is the view of the Radio Protective Association, an organization of independent manufacturers who are fighting the alleged efforts of the Radio Corporation of America to monopolize the radio industry.

"The decision of the Commission can only mean that it will now order immediate action on the 'tube clause,'" said Oswald F. Schuette, executive Secretary of the Radio Protective Association at the Chicago headquarters. "By speedy action the commission would check one of the outstanding efforts of the Radio Trust to destroy its independent competitors. It was to secure just such protection for the freedom of industrial competition that the Federal Trade Commission was created. The independents in the radio industry are entitled to immediate relief.

"The tube is the vital part of a radio set.

The engineering of the latter is based on the characteristics of the tubes to be used in it.

"It is therefore vital that the 'tube clause', which is significant of the whole effort of the Radio Corporation to monopolize the industry, should receive immediate condemnation at the hands of the Commission. Such an action would constitute a most effective step on the part of the

commission to protect the young but vigorous radio industry against this destructive monopoly."

The complaint against the "tube clause" was filed with the Radio Commission a month ago by Arthur D. Lord, receiver for the DeForest Radio Company, one of the largest independent tube manufacturers among the members of the Radio Protective Association.

SEND FOR FREE CATALOG

From Chicago's
Oldest Radio Jobbers
The Most Valuable Radio
Catalog.

Write for your copy today—IT'S FREE!

TELEPHONE MAINTENANCE COMPANY
123-S S. Wells St. Dept. 62 Chicago, Ill.

SET BUILDERS!

Halldorson Overtone Audio and Output transformers are proving a revelation to set builders all over the country. They will give you quality that you never dreamed possible. Try them in your receiver; if they don't astonish you with their lifelike reproduction your money will be gladly refunded. At your dealer or sent direct. Price each \$6.00

THE HALLDORSON COMPANY
Factory: 4745 N. Western Ave. Office: 223 W. Jackson Blvd.
CHICAGO, ILL.

These are the AERO Universal Coils

*Two
Wonderful
Inductances*



*Adaptable
to All
Tubes*

No. 100 AERO Universal Coil (Code U-100) - Price \$4.00
AERO Universal Antenna Coupler (Code U-96) Price \$4.00

That Make Possible the Fine Performance of the QUADRODE Superhetrodyne Receiver

Described Elsewhere in This Issue

Of course you'll want to build the Quadrode Superhetrodyne Receiver featured by Radio Age. It's a mighty good set—powerful, selective, and possessing wonderful tone qualities.

The AERO Universal Coils used in this circuit are responsible, to a great extent, for the splendid efficiency and fine performance of this receiver. These super-sensitive inductance units are twice-matched, and are adaptable to 201-A, 199, 112, and the new 240 and A. C. tubes.

Patented construction features eliminate losses to the greatest possible degree. You'll find these coils the finest inductances thus far produced.

When ordering parts for the Quadrode Superhetrodyne from your dealer, order these AERO Universal Coils by code number.

No. 100 AERO Universal Coil (Code U-100) . . . Price \$4.00
AERO Universal Antenna Coupler (Code U-96) . . . Price \$4.00
You should be able to get the above Aero Coils and parts from your dealer. If he should be out of stock order direct from the factory.

AERO PRODUCTS, Inc.

Dept. 106

1772 Wilson Ave., Chicago, Ill.

Station	Location	Kilo-cycles	Meters	Power	Station	Location	Kilo-cycles	Meters	Power
WHAZ	Troy, N. Y.	980	306	500	WGST	Atlanta, Ga.	1110	270	500
WGR	Buffalo, N. Y.	990	303	750	WMAZ	Macon, Ga.	1110	270	500
KSL	Salt Lake City, Utah	990	303	1000	WSOE	Milwaukee, Wis.	1110	270	500
KFWO	Avalon, Cal.	1000	300	250	KOAC	Corvallis, Oregon	1110	270	500
KMOX	St. Louis, Mo.	1000	300	5000	KFLX	Galveston, Texas	1110	270	100
WPSC	State College, Pa.	1000	300	500	KGU	Honolulu, Hawaii	1110	270	600
WBAK	Harrisburg, Pa.	1000	300	500	WHAD	Milwaukee, Wis.	1110	270	500
KOWW	Walla Walla, Wash.	1000	300	500	WBAO	Decatur, Ill.	1120	268	100
WWNC	Asheville, N. C.	1010	297	1000	WDAE	Tampa, Florida	1120	268	500
KUOA	Fayetteville, Ark.	1010	297	500	KSBA	Shreveport, La.	1120	268	1000
WEPS	Gloucester, Mass.	1010	297	100	KFLV	Rockford, Ill.	1120	268	100
WSMK	Dayton, Ohio	1010	297	200	WLAP	Louisville, Ky.	1120	268	100
KQW	San Jose, Cal.	1010	297	500	KFWI	San Francisco, Calif.	1120	268	500
WDEL	Wilmington, Del.	1010	297	100	KFIZ	Fond du Lac, Wis.	1120	268	100
KGFV	Ravenna, Neb.	1010	297	10	WOBV	Charlestown, W. Va.	1120	268	50
WSMB	New Orleans, La.	1010	297	750	WAAM	Newark, N. J.	1120	268	250
KLZ	Denver, Colo.	1010	297	500	WNJ	Newark, N. J.	1120	268	250
WODA	Paterson, N. J.	1020	294	1000	WGCP	Newark, N. J.	1120	268	250
WTMJ	Milwaukee, Wis.	1020	294	1000	WFPG	Altoona, Pa.	1120	268	100
KPRC	Houston, Tex.	1020	294	500	WNOX	Knoxville, Tenn.	1130	265	1000
WLBW	Oil City, Pa.	1020	294	500	WOI	Ames, Iowa	1130	265	2500
KGCH	Wayne, Neb.	1020	294	250	WHK	Cleveland, Ohio	1130	265	500
WGL	New York, N. Y.	1020	294	1000-500	KTSA	San Antonio, Texas	1130	265	2000
KGDW	Humboldt, Neb.	1020	294	100	KKP	Seattle, Wash.	1130	265	15
KGEZ	Kalispell, Mont.	1020	294	100	WBES	Takoma Park, Md.	1130	265	100
WDBO	Orlando, Fla.	1040	288	500-1000	WICC	Sport Hill, Conn.	1130	265	500
WENR	Chicago, Ill.	1040	288	500	WCWS	Danbury, Conn.	1130	265	100
WBCN	Chicago, Ill.	1040	288	250	WSEA	Virginia Beach, Va.	1140	263	500
KTBI	Los Angeles, Cal.	1040	288	500	WJAZ	Chicago, Ill.	1140	263	5000
WNAT	Philadelphia, Pa.	1040	288	100	WMBI	Chicago, Ill.	1140	263	500
KGBX	St. Joseph, Mo.	1040	288	100	WDAG	Amarillo, Texas	1140	263	250
WKY	Oklahoma City, Okla.	1040	288	150	KGEF	Los Angeles, Calif.	1140	263	500
WSSH	Boston, Mass.	1040	288	100	WJBO	New Orleans, La.	1140	263	100
WBET	Boston, Mass.	1040	288	500	KFPW	Cartersville, Mo.	1140	263	50
WIAD	Philadelphia, Pa.	1040	288	100	KGCK	Yuma, Colo.	1140	263	10
WBAL	Baltimore, Md.	1050	285	5000	WJBI	Red Bank, N. J.	1140	263	250
KFAU	Boise, Idaho	1050	285	2000-4000	WEAM	N. Plainfield, N. J.	1140	263	250
WJAG	Norfolk, Neb.	1050	285	250-500	KGHP	Hardin, Mont.	1140	263	50
KLCN	Blytheville, Ark.	1050	285	50	WRHM	Minneapolis, Minn.	1150	261	1000
KMMJ	Clay Center, Neb.	1050	285	250-500	WOOD	Grand Rapids, Mich.	1150	261	500
WCAL	Northfield, Minn.	1050	285	500	KGA	Spokane, Wash.	1150	261	2000
WDGY	Minneapolis, Minn.	1050	285	500	WHBA	Oil City, Pa.	1150	261	10
WAIU	Columbus, Ohio	1060	283	5000	WCAU	Philadelphia, Pa.	1150	261	500
KFXF	Denver, Colo.	1060	283	500	WCMA	Culver, Ind.	1150	261	500
KFJR	Portland, Ore.	1060	283	100	WDWF	Cranston, R. I.	1150	261	250
KTBR	Portland, Ore.	1060	283	50	WLSI	Hopkinsville, Ky.	1150	261	750
WRAK	Escanaba, Mich.	1060	283	50	WFIW	Hopkinsville, Ky.	1150	261	750
WEAO	Columbus, Ohio	1060	283	750	WFBL	Syracuse, N. Y.	1160	258	750
WDRC	New Haven, Conn.	1060	283	500	WEBW	Beloit, Wis.	1160	258	500
KFUM	Colorado Springs, Colo.	1060	283	1000	WNAL	Omaha, Nebr.	1160	258	250
KTAB	Oakland, Cal.	1070	280	500	KOCH	Omaha, Nebr.	1160	258	250
WHAM	Rochester, N. Y.	1070	280	5000	KFOX	Omaha, Nebr.	1160	258	100
KWWG	Brownsville, Texas	1080	278	500	KFUL	Galveston, Texas	1160	258	500
WDZ	Tuscola, Ill.	1080	278	100	KDYL	Salt Lake City, Utah	1160	258	100
WGHP	Mt. Clemens, Mich.	1080	278	750	WIL	St. Louis, Mo.	1160	258	250
WKAR	E. Lansing, Mich.	1080	278	500	WBT	Charlotte, N. C.	1160	258	500
WNAX	Yankton, S. Dak.	1080	278	1000	WSBF	St. Louis, Mo.	1160	258	250
WTAS	Chicago, Ill.	1090	275	3500	KTNT	Muscatine, Iowa	1170	256	2000
KFSG	Los Angeles, Calif.	1090	275	500	WCOS	Springfield, Ohio	1170	256	500
KFPL	Dublin, Texas	1090	275	15	KRE	Berkeley, Calif.	1170	256	100
KFBB	Havre, Mont.	1090	275	50	KFUS	Oakland, Calif.	1170	256	50
WFBM	Indianapolis, Ind.	1090	275	250	WBRR	Rossville, N. Y.	1170	256	1000
WEAN	Providence, R. I.	1090	275	500	WASH	Grand Rapids, Mich.	1170	256	250
KFSG	Los Angeles, Calif.	1090	275	500	WEBJ	New York, N. Y.	1170	256	500
WHAR	Atlantic City, N. J.	1100	273	1000	WLTH	Brooklyn, N. Y.	1170	256	250
WPG	Atlantic City, N. J.	1100	273	5000	KGFX	Pierre, S. D.	1180	254	200
WRM	Urbana, Ill.	1100	273	500	WRVA	Richmond, Va.	1180	254	1000
WBAA	LaFayette, Ind.	1100	273	500	WREN	Lawrence, Kansas	1180	254	750
KFJF	Oklahoma City, Okla.	1100	273	750	KFKU	Lawrence, Kansas	1180	254	500
KFAD	Phoenix, Ariz.	1100	273	500	KMO	Takoma, Wash.	1180	254	250
WFBJ	Collegeville, Minn.	1100	273	100	WTAQ	Eau Claire, Wis.	1180	254	500
KSMR	Santa Marie, Cal.	1100	273	100	WCAX	Burlington, Vt.	1180	254	100
WDFD	Flint, Mich.	1100	273	100	KFHA	Gunnison, Colo.	1180	254	50
WSKC	Bay City, Mich.	1100	273	250	KGDA	Dell Rapids, S. D.	1180	254	15
KLDS	Independence, Mo.	1110	270	1500	WHEC- WABO	Rochester, N. Y.	1180	254	100
WJAS	Pittsburgh, Pa.	1110	270	500	KPLA	Los Angeles, Calif.	1190	252	500
KQV	Pittsburgh, Pa.	1110	270	500					

Crosley Reviews Year

Powel Crosley, Jr., President, The Crosley Radio Corporation, says: "The saturation point in radio is far away. We anticipate no radical change in radio development during 1928. The trend will continue toward the AC type of set with many replacements of earlier battery-operated receivers. The demand for replacement of old equipment with new, up-to-date sets will be greater than ever in 1928.

"Unquestionably the most valuable or important radio development in 1927 was the AC tubes, bringing real AC operation in the radio receiving set. The changes are many. A small transformer supplying different voltages to provide the heat necessary to make a vacuum tube function, replaces the storage battery with its necessary charger or trickle-charger to supply current for the filaments or heaters.

"Economy of current is not so essential, when it is taken direct from the light socket as it is if the current is taken from a storage battery. The tubes, therefore, have much greater emission and greater ability to perform efficiently and give greater volume without distortion. These are but two of the important changes—there are many others.

"The trend is now unquestionably towards the AC set using AC tubes, wherever electric light current is available. 1927 has seen the development of more efficient receiving sets at lower prices than ever before. 1927 has brought better tone quality through more extensive use of power output tubes and improved loud speaking devices."

Make any set better with FROST-RADIO

Again Specified in Radio Age Circuits in This Issue. Note This List:



FROST-RADIO

Frost-Radio again wins recognition as the leading line of radio parts through its specification in the following circuits described in this issue:

1. The New Infradyne.
2. The Melo-Heald Hot-Spot 14.
3. The Quadrode Super.
4. The Radio Age B Eliminator.



FROST-RADIO

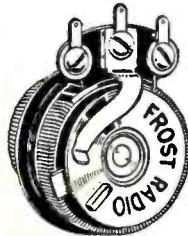

FROST-RADIO

When you build these receivers, amplifiers or eliminators, be sure to use the Frost Parts called for in the specifications. Your dealer can supply you with the Frost and other parts you will need. See him today.



FROST-RADIO

Write for our Free Book "What Set Shall I Build?"

HERBERT H. FROST, INC.

Chicago

ELKHART, IND.

New York



THE NEW YEAR

A FLOWER unblown, a Book unread
 A Tree with fruit unharvested
 A Path untrod, a House whose rooms
 Lack yet the heart's divine perfume
 A Landscape whose wide border lies
 In silent shade 'neath silent skies
 A wondrous Fountain yet unsealed
 A Casket with its gifts concealed
 This is the year that for you waits
 Beyond tomorrow's mystic gates.

—Horatio Nelson Powers.



Super-excellent Cabinet, 10 or 12 In. deep

EHLERT'S RADIO DESK

Put Your Set in Beautiful Radio Furniture Cabinets for any set

29 Models—Positively the Finest

Table Cabinets, Desks, Speaker Consoles, Battery Consoles to fit any advertised circuit like Quadrode Super as advertised in Radio Age, Tyrman 10, World's Record 10, 9 In Line, Camfields, Silver Marshall or popular sets like Radiola 16 or 17, any Atwater Kent model, in fact any receiving set that has panel 9x30 or smaller.

WRITE YOUR OWN TICKET
 YOU BE THE JUDGE—JUDGE
 THEM ON ANY POINT FOR

Charming grace of design, refinement, unusual beauty, smart appointments, graceful shapings, beautifully grained and matched Butt Walnut, exceptional fine lacquer finish, true regard for distinctive and artistic beauty.

If you want Furniture that will compare favorably with other furnishings for the drawing-room, library or living-room, made by a firm with 40 years' experience and a reputation for making beautiful Furniture, ask to see our Furniture at your jobber or dealer, or call at our Chicago show-rooms and warehouse where we have on display our complete line.

Catalog and prices on request

EHLERT RADIO FURNITURE CO.

2468 Lincoln Avenue

Phone Diversey 2568

CHICAGO, ILLINOIS

Make Your Receiver Do All the Manufacturer Claims It Can!

Easily, Cheaply, Quickly! Simply wonderful—Wonderfully simple. Not a trick, but a plain, practical, proven fact. The answer is a

Scott's Tuned Radio Antenna

(Single Pole)—Description FREE

Write to L. T. Scott, 719 First St., New Orleans, La.

FREE Wholesale Radio Catalog

Dealer-Set Builders! Save Money!

Send for this book of bargains. Everything in Radio—all the newest hook-ups. Sets, kits, parts, cabinets, consoles and supplies. If you want the best for the least money, you need this catalog.

SHURE RADIO COMPANY

341 G-West Madison St. Chicago, Ill.



Station	Location	Kilo-Cycles	Meters	Power	Station	Location	Kilo-Cycles	Meters	Power
WOK	Homewood, Ill.	1190	252	5000	WGES	Chicago, Ill.	1240	242	500
WMBB					WGES	Chicago, Ill.	1240	242	500
WSAR	Fall River, Mass.	1190	252	100	KFON	Long Beach, Calif.	1240	242	200
WKJC	Lancaster, Pa.	1190	252	50	WEBR	Buffalo, N. Y.	1240	242	250
WGAL	Lancaster, Pa.	1190	252	15	WEBC	Superior, Wis.	1240	242	10
WKBFB	Indianapolis, Ind.	1190	252	250	WNBX	Springfield, Vt.	1240	242	250
WMBR	Tampa, Fla.	1190	252	100	WMAL	Washington, D. C.	1240	242	250
WKBT	New Orleans, La.	1190	252	50	WBRG	Birmingham, Ala.	1240	240	250
WFAM	St. Cloud, Minn.	1190	252	10	WJAM	Cedar Rapids, Iowa	1250	240	250
KOCW	Chickasha, Okla.	1190	252	250	KWCR	Cedar Rapids, Iowa	1250	240	500
WORD	Batavia, Ill.	1190	252	5000	WNAD	Norman, Okla.	1250	240	2500
WBAX	Wilkes-Barre, Pa.	1200	250	100	KEX	Portland, Oregon	1250	240	100
WBRE	Wilkes-Barre, Pa.	1200	250	100	WIBA	Madison, Wis.	1250	240	100
KFRU	Columbia, Mo.	1200	250	500	KGCU	Mandan, N. D.	1250	240	100
WCOA	Pensacola, Fla.	1200	250	500	WBBP	Petosky, Mich.	1250	240	100
KFOU	Holy City, Calif.	1200	250	100	WOAX	Trenton, N. J.	1250	240	500
KFJI	Astoria, Ore.	1200	250	15	WCAP	Asbury Park, N. J.	1250	240	500
WIBR	Steubenville, Ohio	1200	250	50	WOAN	Lawrenceburg, Tenn.	1250	240	500
KFJZ	Fort Worth, Texas	1200	250	50	WTAL	Toledo, Ohio	1250	240	250
WHBY	West de Pere, Wis.	1200	250	50	WBAW	Nashville, Tenn.	1250	240	500
KMED	Medford, Ore.	1200	250	50	WRAW	Reading, Pa.	1260	238	100
KFYR	Bismarck, N. D.	1200	250	250	WLBI	East Wenona, Ill.	1260	238	250
KFKA	Greeley, Colo.	1200	250	200	WRBC	Valparaiso, Ind.	1260	238	250
WCAZ	Carthage, Ill.	1200	250	50	WJBW	New Orleans, La.	1260	238	30
WBBY	Charleston, S. C.	1200	250	75	KFVI	Houston, Texas	1260	238	50
KFUT	Salt Lake City, Utah	1200	250	50	WIBX	Utica, N. Y.	1260	238	150
WSAZ	Huntington, West Va.	1200	250	100	WJBB	Sarasota, Fla.	1260	238	250
WREC	Memphis, Tenn.	1200	250	100	WQBA	Tampa, Fla.	1260	238	250
WSIX	Springfield, Tenn.	1200	250	150	WABZ	New Orleans, La.	1260	238	50
WKDR	Kenosha, Wis.	1210	248	15	WADC	Akron, Ohio	1260	238	1000
WFKD	Philadelphia, Pa.	1210	248	50	KHMC	Harlingen, Texas	1270	236	100
WABW	Wooster, Ohio	1210	248	50	KFDX	Shreveport, La.	1270	236	250
WABY	Philadelphia, Pa.	1210	248	50	WGBF	Evansville, Ind.	1270	236	250
WCAT	Rapid City, S. D.	1210	248	100	KFMX	Northfield, Minn.	1270	236	500
WIOD	Miami Beach, Fla.	1210	248	1000	KFWM	Oakland, Calif.	1270	236	500
KFEL	Denver, Colo.	1210	248	250	WHAP	Carlstadt, N. J.	1270	236	1000
KFBC	San Diego, Calif.	1210	248	100	WPUB	New York City, N. Y.	1270	236	500
WEBE	Cambridge, Ohio	1210	248	10	WTAR	Norfolk, Va.	1270	236	500
KFJB	Marshalltown, Iowa	1210	248	100	WHBC	Canton, Ohio	1270	236	10
KGCA	Decorah, Iowa	1210	248	10	WBBW	Norfolk, Va.	1270	236	50
WLGI	Ithaca, N. Y.	1210	248	50	WTAD	Quincy, Ill.	1270	236	500
WRAM	Galesburg, Ill.	1210	248	50	WBNY	New York, N. Y.	1270	236	500
WFBZ	Galesburg, Ill.	1210	248	50	WSRO	Middletown, Ohio	1270	236	100
KWLC	Decorah, Iowa	1210	248	50	KWK	St. Louis, Mo.	1280	234	1000
KOW	Denver, Colo.	1210	248	250	WMBS	Lemoyne, Pa.	1280	234	250
WLBT	Crown Point, Ind.	1210	248	50	KVI	Tacoma, Wash.	1280	234	50
WJBA	Joliet, Ill.	1210	248	50	WMPC	Lapeer, Mich.	1280	234	30
WTAX	Streator, Ill.	1210	248	50	WMAN	Columbus, Ohio	1280	234	50
WRRS	Racine, Wis.	1210	248	50	WJBY	Gadsden, Ala.	1280	234	50
WLBR	Belvedere, Ill.	1210	248	15	KGAR	Tucson, Ariz.	1280	234	100
WNBH	New Bedford, Mass.	1210	248	250	WJAK	Kokomo, Ind.	1280	234	50
WGBB	Freeport, N. Y.	1220	246	400	WFBC	Knoxville, Tenn.	1280	234	50
WAAT	Jersey City, N. J.	1220	246	300	WDAH	El Paso, Texas	1280	234	100
WEVD	Woodhaven, N. Y.	1220	246	500	WCAH	Columbus, Ohio	1280	234	250
WHDI	Minneapolis, Minn.	1220	246	500	WMA Y	St. Louis, Mo.	1280	234	100
WLB	Minneapolis, Minn.	1220	246	500	KFQA	St. Louis, Mo.	1280	234	50
KFH	Wichita, Kansas	1220	246	500	WBBL	Richmond, Va.	1280	234	100
KZM	Oakland, Calif.	1220	246	100	WNBZ	Saranac Lake, N. Y.	1290	232	10
KLS	Oakland, Calif.	1220	246	250	WJKS	Gary, Ind.	1290	232	500
WFBE	Cincinnati, Ohio	1220	246	250	WSBC	Chicago, Ill.	1290	232	500
KFPY	Spokane, Wash.	1220	246	250	WBRL	Tilton, N. H.	1290	232	500
KFIO	Spokane, Wash.	1220	246	100	KUT	Austin, Texas	1290	232	500
WKRC	Cincinnati, Ohio	1220	246	500	KFOZ	Hollywood, Calif.	1290	232	100
WWL	New Orleans, La.	1220	246	500	KFPR	Los Angeles, Calif.	1290	232	250
KWUC	LeMars, Iowa	1230	244	1500	WMBJ	Monessen, Pa.	1290	232	50
KSCJ	Sioux City, Iowa	1230	244	500	WHBQ	Memphis, Tenn.	1290	232	100
KGY	Lacey, Wash.	1230	244	50	KFEY	Kellogg, Idaho	1290	232	10
KGRS	Amarillo, Texas	1230	244	150	WLBH	Farmingdale, N. Y.	1290	232	30
KFCB	Phoenix, Ariz.	1230	244	125	KFMR	Sioux City, Iowa	1290	232	100
KGCX	Vida, Montana	1230	244	10	KFJY	Fort Dodge, Iowa	1290	232	100
WMBC	Detroit, Mich.	1230	244	100	KFEQ	St. Joseph, Mo.	1300	231	1000
WFBR	Baltimore, Md.	1230	244	100	KGCL	Seattle, Wash.	1300	231	50
WCAD	Canton, N. Y.	1230	244	1000	KPCB	Seattle, Wash.	1300	231	50
WDOD	Chattanooga, Tenn.	1230	244	500	WQAN	Scranton, Pa.	1300	231	250
WCAO	Baltimore, Md.	1230	244	250	WGBI	Scranton, Pa.	1300	231	250
WFCI	Pawtucket, R. I.	1240	242	50	KFFM	Greenville, Texas	1300	231	15
KFKB	Milford, Kansas	1240	242	1500	WDBJ	Roanoke, Va.	1300	231	250
WEDC	Chicago, Ill.	1240	242	500	WCOC	Columbus, Miss.	1300	231	250
					WIBZ	Montgomery, Ala.	1300	231	15



Exclusively Licensed by Technidyne Corporation Under U. S. Patent Nos. 1593658, 1034103, 1034104.

Specified by Experts

ELECTRAD Royalty Variable High Resistances

To obtain the best results from your set, insist on the Variable High Resistances of proven accuracy and dependability. Electrad Royalties are the choice of radio experts because of such superior, exclusive features as:

- 1—Contact made positive by metallic arm on wire-wound strip.
- 2—Same resistance always obtained at the same point.

A range for every purpose—11 in all. Type E. \$2.00. All other types \$1.50.

Write for hook-up circular.

Dept. 63C 175 Varick St., New York, N. Y.

ELECTRAD

Power Tube

(Continued from page 15)

a three volt positive potential will be impressed on the grid—the very thing we want to prevent. It can be seen that for a given amount of amplification, or volume, the type of tube, and the grid bias, and plate voltage are the primary factors.

The subject of obtaining "quality," or undistorted reproduction is not given the attention it deserves. It is true that many articles have appeared in various periodicals at different times concerning the construction of power devices and amplifiers capable of delivering large out-puts, but in most cases the builder is ignorant of what is taking place in the appliance he is building, and of the requirements of the same for true reproduction. Articles devoted to this subject will appear in coming issues of RADIO AGE; written to give the experimenter and layman a better understanding of the audio frequency amplifier and reproducer. Only a small portion of the distortion of the received music takes place in the portion of the set which is ahead of the detector. The audio amplifier system and reproducer are directly responsible for the reproduction—assuming, of course, that the music received from the broadcasting station is perfect, or almost so, and that the radio frequency amplifier is not too sharp.

For the present, we suggest that the reader who is still operating his set with the general purpose tube in the last stage and operating a loud speaker from it, invest in some type of power tube. If B batteries are used and the most economical operation is an objective then the 112 type tube should be used with a plate voltage of 135 volts, and a C bias of 9 volts. It must be remembered that the loudspeaker volume is limited with this tube, but very much better than with the use of the 201A type. Where the "99" tubes are used a "120" tube with a plate voltage of 135 volts and a C bias of 22½ volts. The undistorted power out-put of this latter tube is 120 milliwatts, but the amplification of the tube is only 3.3 as compared with 6.6 of the "99" tube which it replaces. Where a B supply unit is available the 171 type of tube has a distinct advantage, and 180 volts should be applied to the plate (most B eliminators supply this) with a C bias of about 40 volts.

for power circuits

It has become standard practice to use

Parvult Wound Condensers

in circuits which quickly break down ordinary by-pass or filter condensers.

You will find that the same characteristics of accuracy, high direct current resistance, and the ability to give continuous duty at full rated voltage, make them desirable in circuits where even a poor condenser might "get by."



THE ACME WIRE COMPANY, NEW HAVEN, CONNECTICUT

PARVULT WOUND CONDENSERS

XL Products
Pepup Your Set!

Model "N" Variable Condenser

Quick and easy tuning—more volume, clearness, stability, with an X-L Varlo-Densar in your circuit. Specified and endorsed by foremost radio designers in all latest and best hook-ups.

MODEL "N"—Micrometer adjustment easily made, assures exact oscillation control in all tuned radio frequency circuits. Neutrodyne, Roberts 2-tube, Browning, Drake, Silver's Knockout. Capacity Range 1.8 to 20 Mfd. Price \$1.00.

MODEL "G"—Obtains the proper grid capacity on Cockaday circuit, filter and intermediate frequency tuning in super-heterodyne and positive grid bias in all sets. Capacity range. Model G-1 .0002 to .0001 Mfd. Model G-5 .0001 to .0005 Mfd. Model G-10 .0003 to .001 Mfd. Price each with grid clips \$1.50.

X-L PUSH POST—NEW! Bakelite Insulated—Push it down with your thumb, insert wire, remove pressure, wire is firmly held. Vibrations will not loosen, releases instantly. Price each, 15c. Also in strip of 7 on black panel marked in white. Price \$1.50.

FREE—New, up-to-date book of wiring diagrams showing use of X-L units, in the new LOFTINWHITE constant coupled radio frequency circuit, and in other popular hook-ups. Write today.

X-L RADIO LABORATORIES
2424 N. Lincoln Ave. Chicago, Ill.

NEW YEAR - NEW IDEA
PATENT YOUR IDEAS
FREE—Inventors Recording Blank Confidential Advice—Send Sketch
Z. H. POLACHEK Reg. Patent Attorney
Consult. Engineer
1234 Broadway, NEW YORK

'B' BATTERY ELIMINATOR

Only \$7.95

NEW IMPROVED 1928 MODEL
No more worry with "B" Batteries! Hook up a Roll-O "B" Battery Eliminator and forget battery troubles forever. This wonderful new invention means better reception, sharper tuning. Gives you more real pleasure from your set. Completely Equipped—No "Extras" to Buy Operates perfectly on direct or alternating current, giving up to 90 volts current, and using the full wave of the power supply. Simple directions enclosed—anyone can plug it in to any kind of set with up to six tubes. Constant voltage gives you more power. Costs no more than set of good "B" Batteries. Solidly built in beautifully finished metal case, with genuine Bakelite top.

SEND YOUR ORDER NOW
Don't blame your set because run down "B" Batteries won't let it work right. Order your Eliminator NOW. Write name and address on a piece of paper, pin a dollar bill to it, and mail it TODAY. Pay postman balance (\$6.95 plus a few cents postage) when he delivers your Eliminator. Use it ten days. If not more than satisfied, return it and get your money back.

THE ROLL-O RADIO CO.
Dept. B-201 3d & Sycamore, Cincinnati, O.

Federal Corporation

The Federal Radio Corporation announces the appointment of W. F. Kroening as territorial representative in Michigan to replace H. H. Wilkin, who has been transferred to California. Although a new member of the Federal sales organization, Mr. Kroening has had several years of selling experience in radios, and is expected to continue the good record in Michigan. He will work in conjunction with the Grier-Sutherland Company, Detroit, wholesalers for Federal Ortho-sonic radio in that territory. Mr. Wilkin's assignment to California fills the post left vacant by P. J. Rundle, who was recently made special representative.

6 TUBE RADIO

ONE DIAL Latest advanced circuit. All steel chassis totally shielded. Balanced parts of best quality. Marvelous power and selectivity. Gets the long range stations as clear as a bell. One dial single control. An unsurpassed value—just one of our many mighty bargains.

Only \$32.50

FREE Log and Call Book and Big New Catalog—just off the press. Full of Radio Bargains. Send for your free copy now!

American Auto & Radio Mfg. Co.
FLARRY SCHWARTZBERG, Pres.
Dept. 132 American Radio Bldg., Kansas City, Mo.



Please Mention Radio Age When Writing to Advertisers.

Station	Location	Kilo-cycles	Meters	Power	Station	Location	Kilo-cycles	Meters	Power
KDLR	Devils Lake, N. D.	1300	231	15	WJBK	Ypsilanti, Mich.	1360	220	15
WLBM	Boston, Mass.	1300	231	50	WHBU	Anderson, Ind.	1360	220	15
WAFD	Detroit, Mich.	1300	231	100	KRAC	Shreveport, La.	1360	220	50
WAAD	Cincinnati, Ohio.	1300	231	25	KGRC	San Antonio, Texas.	1360	220	50
WOWO	Fort Wayne, Ind.	1310	229	1000	WMBO	Auburn, N. Y.	1360	220	100
WMBL	Lakeland, Fla.	1310	229	50	KGFI	San Angelo, Texas.	1360	220	15
KWJJ	Portland, Ore.	1310	229	50	KJBS	San Francisco, Calif.	1360	220	50
WKBE	Webster, Mass.	1310	229	100	WMBG	Richmond, Va.	1360	220	15
KTAP	San Antonio, Tex.	1310	229	20	WGWB	Milwaukee, Wis.	1370	219	500
WHBP	Johnstown, Pa.	1310	229	250	WKBO	New York City, N. Y.	1370	219	500
WNBR	Memphis, Tenn.	1310	229	20	WKBQ	New York City, N. Y.	1370	219	500
KGBU	Ketchikan, Alaska.	1310	229	500	KGEW	Fort Morgan, Colo.	1370	219	200
KELW	Burbank, Calif.	1310	229	250	WKBC	Birmingham, Ala.	1370	219	10
KPPC	Pasadena, Calif.	1310	229	50	WCGU	Sea Gate, Coney Isld., N. Y.	1370	219	500
WGBC	Memphis, Tenn.	1310	229	15	WLBQ	Atwood, Ill.	1370	219	25
WWAE	Chicago, Ill.	1320	227	500	WKBW	Buffalo, N. Y.	1380	217	500
KSO	Clarinda, Iowa.	1320	227	500	KGDM	Stockton, Calif.	1380	217	10
WCLO	Camp Lake, Wis.	1320	227	100	KFQW	Seattle, Wash.	1380	217	100
WJBC	LaSalle, Ill.	1320	227	100	WRES	Quincy, Mass.	1380	217	50
KGEU	Lower Lake, Calif.	1320	227	50	WKBV	Brookville, Ind.	1380	217	100
WARS- WSDA	Brooklyn, N. Y.	1320	227	500	WKBS	Galesburg, Ill.	1380	217	100
WJAY	Cleveland, Ohio.	1320	227	500	WLBO	Galesburg, Ill.	1380	217	100
WBBC	New York City, N. Y.	1320	227	500	KFOR	Lincoln, Nebr.	1380	217	100
WFJC	Akron, Ohio.	1320	227	250	WIBU	Poynette, Wis.	1380	217	20
WCBE	New Orleans, La.	1320	227	5	WKBB	Joliet, Ill.	1390	216	150
KFUP	Denver, Colo.	1320	227	100	WCLS	Joliet, Ill.	1390	216	150
WAIZ	Appleton, Wis.	1320	227	100	WEHS	Evanston, Ill.	1390	216	100
KXRO	Aberdeen, Wash.	1320	227	50	WHFC	Chicago, Ill.	1390	216	200
WTHS	Atlanta, Ga.	1320	227	200	WPEP	Waukegan, Ill.	1390	216	250
KGHB	Honolulu, T. H.	1320	227	250	KGER	Long Beach, Calif.	1390	216	100
WSYR	Syracuse, N. Y.	1330	225	500	KRLO	Los Angeles, Calif.	1390	216	250
WMAC	Cazenovia, N. Y.	1330	225	500	WQAA	Parkesburg, Pa.	1390	216	500
WLAC	Nashville, Tenn.	1330	225	1000	KFDZ	Minneapolis, Minn.	1390	216	10
WLDAD					1390	216	50		
KFIU	Juneau, Alaska.	1330	225	10	KGCB	Oklahoma City, Okla.	1390	216	50
WCOT	Olneyville, R. I.	1330	225	100	KGFG	Oklahoma City, Okla.	1390	216	50
WAGM	Royal Oak, Mich.	1330	225	50	KFFJ	Edgewater, Colo.	1390	216	50
KFVG	Independence, Kans.	1330	225	50	WOKO	Peekskill, N. Y.	1390	216	250
KGEN	El Centro, Calif.	1330	225	15	WLEX	Lexington, Mass.	1390	216	5
KFKZ	Kirksville, Mo.	1330	225	15	WKBI	Chicago, Ill.	1390	216	50
KFUR	Ogden, Utah.	1330	225	50	KFIF	Portland, Ore.	1400	214	50
WCBM	Baltimore, Md.	1330	225	100	KFEC	Portland, Ore.	1400	214	50
WFAN	Philadelphia, Pa.	1340	224	500	WAIT	Taunton, Mass.	1400	214	10
KFXR	Oklahoma City, Okla.	1340	224	50	WKBN	Youngstown, Ohio.	1400	214	50
WCAM	Camden, N. J.	1340	224	500	WMBW	Youngstown, Ohio.	1400	214	50
WFKB	Chicago, Ill.	1340	224	500	WLBG	Petersburg, Va.	1400	214	00
WCRW	Chicago, Ill.	1340	224	500	KFWF	St. Louis, Mo.	1400	214	250
KGFH	La Crescenta, Calif.	1340	224	250	WJBU	Lewisburg, Pa.	1400	214	100
KMIC	Inglewood, Calif.	1340	224	250	KPJM	Prescott, Ariz.	1400	214	15
KFBL	Everett, Wash.	1340	224	50	WCWK	Fort Wayne, Ind.	1400	214	250
WKAV	Laconia, N. H.	1340	224	50	WRAX	Philadelphia, Pa.	1410	213	250
WSAJ	Grove City Park, Pa.	1340	224	250	KGBZ	York, Nebr.	1410	213	100
KGFB	Iowa City, Iowa.	1340	224	10	KTUE	Houston, Texas.	1410	213	5
KGDP	Pueblo, Colo.	1340	224	10	WJBL	Decatur, Ill.	1410	213	250
WNRC	Greensboro, N. C.	1340	224	500	WKBP	Battle Creek, Mich.	1410	213	50
KGFK	Hallock, Minn.	1340	224	50	KFHL	Oskaloosa, Iowa.	1410	213	10
WEBQ	Harrisburg, Ill.	1340	224	15	KGFP	Mitchell, S. D.	1410	213	10
KFVS	Cape Girardeau, Mo.	1340	224	50	KGDZ	Shreveport, La.	1410	213	250
WOCL	Jamestown, N. Y.	1340	224	25	KGGH	Cedar Grove, La.	1410	213	50
WPCC	Chicago, Ill.	1340	224	500	KRSC	Seattle, Wash.	1420	211	50
KFWC	San Bernardino, Calif.	1350	222	100	WCDA	Cliffside, N. J.	1420	211	250
WSAN	Allentown, Pa.	1350	222	100	WBRS	Brooklyn, N. Y.	1420	211	100
WCBA	Allentown, Pa.	1350	222	100	WRST	Bay Shore, N. Y.	1420	211	250
WHBD	Bellefontaine, Ohio.	1350	222	100	WNBO	Washington, Pa.	1420	211	15
WHBF	Rock Island, Ill.	1350	222	100	WMES	Boston, Mass.	1420	211	50
KWKC	Kansas City, Mo.	1350	222	100	WBMH	Detroit, Mich.	1420	211	100
WOMT	Manitowoc, Wis.	1350	222	100	KPNP	Muscatine, Iowa.	1420	211	100
KGFL	Trinidad, Colo.	1350	222	50	KFCR	Santa Barbara, Calif.	1420	211	50
KWTC	Santa Ana, Calif.	1350	222	100	KGFM	Yuba City, Calif.	1420	211	15
KGBY	Columbus, Nebr.	1350	222	50	KFYO	Breckenridge, Texas.	1420	211	15
WAMD	Minneapolis, Minn.	1350	222	500	WLOE	Chelsea, Mass.	1420	211	100
KFOY	St. Paul, Minn.	1350	222	250	KGHC	Slayton, Minn.	1430	210	15
KGCI	San Antonio, Texas.	1360	220	15	WOKT	Rochester, N. Y.	1430	210	500
WKBH	LaCrosse, Wis.	1360	220	500	KVOS	Bellingham, Wash.	1430	210	50
KXL	Portland, Ore.	1360	220	50	WPRC	Harrisburg, Pa.	1430	210	100
WTAZ	Richmond, Va.	1360	220	15	WRCV	Norfolk, Va.	1430	210	100
WHBW	Philadelphia, Pa.	1360	220	100	WLBC	Muncie, Ind.	1430	210	50
					WMBM	Memphis, Tenn.	1430	210	10
					WLBK	Kansas City, Mo.	1430	210	50

LOOK!

The Last Word in RADIO

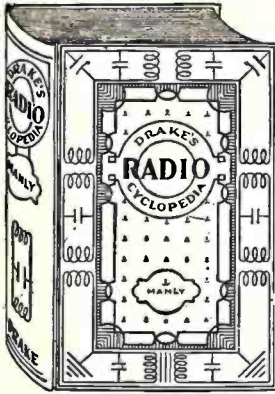

Radio is an exact science, yet so new there is still much that is incorrect and unscientific in present equipment. The results are faulty reception and complaints.

To meet this need we have compiled the exact facts covering the entire scope of radio science and every type of receiver into one big, fine, new book. With it you can now *Be The Man Who Knows!*

DRAKE'S RADIO CYCLOPEDIA

Solves the Dealer's Service Problems

If you design, build, repair or service radio receivers you need this book. All subjects alphabetically arranged, with hundreds of cross references so you quickly find what you want. 1672 headings, 985 illustrations, 871 pages. Nothing else like it. It is the book of radio, just out. **SEND TODAY.** \$6.00 postpaid. Also for sale at all bookstores.

Big catalog of useful books sent free

RADIO AGE, Inc.
500 N. Dearborn Street
CHICAGO



Self-Adjusting!

For best performance your tubes require a variable filament control to supply the definite current they need, despite "A" battery variations. **AMPERITE** is the only self-adjusting and automatic filament tube control that does this. Takes the "guess," inconvenience and unsightliness out of panel rheostats. Simplifies wiring, panel design, and tuning. Prolongs tube life. Order by name. Accept nothing else. Price \$1.10 mounted (in U. S. A.). For sale by all dealers. Write for **FREE "AMPERITE BOOK"** of season's best circuits and latest construction data. Address Dept. RA12

RADIALL COMPANY
50 Franklin St., New York

AMPERITE

REG. U. S. PAT. OFF.

The "SELF-ADJUSTING" Rheostat.

Free Mailing Lists

Will help you increase sales Send for **FREE** catalog giving counts and prices on thousands of classified names of your best prospective customers—National, State and Local—Individuals, Professions, Business Concerns.

99% by refund of 5¢ each

ROSS-Gould Co. 313 N. 10th St. St. Louis

R. M. A. Trade Show

Director Herbert H. Frost, Chairman of the Association Show Committee has announced the date of the 2nd R. M. A. Trade Show as June 11-15, 1928, to be held at the Stevens Hotel, Chicago, Illinois.

Last year it was impossible to properly take care of all members because of the lack of space but this year Mr. Frost states that in addition to the Exhibition Hall, he has also arranged with the Stevens Hotel for use of the Grand Ballroom which will make available over 30,000 sq. ft. of exhibition space. Space application blanks will be mailed to all members within a few days.

Admittance this year will be the same as last, that is by invitation only to jobbers and dealers, and such others as the Show Committee might determine.

No applications for space at this Trade Show will be accepted from new members after February 15, 1928.

During the Trade Show week the Fourth Annual Convention of the Association will be held and reports received from all standing and special committees. The annual election of officers will also be held for the year 1928-29.

The R. M. A. Annual Banquet will also be held during the week of the Show.

The Hot Spot Fourteen

(Continued from page 20)

ing diagram of Figure 5 carefully. Rather than to obtain parallel wires and angles, a point should be made to get the wiring as direct as possible, thus insuring short wires; one of the most important factors in building radio sets. The by-pass condensers should be clamped between straps made of thin brass strips and mounted on fiber or metal bushings to the sub-panel. In this manner the condensers are suspended from the sub-panel rather than mounted directly to it. The object is to permit clearance for wiring and other parts. The small Sangamo condensers are mounted the same way. The bottom view of the sub-panel in Figure 4 corresponds to the drawing of Figure 5 completing the lay-out in every detail.

In the blue-print the relation of all parts to one another are illustrated. The top is the rear of the front panel with all parts mounted thereto, and the bottom the top view of the sub-panel. The two 1 mfd by-pass condensers are mounted to the base-board. Reference should be made to the photograph in Figure 8, showing the top view of the completed set.

The tube requirements for the set are five 201A type, eight 199 type, and one power tube of the 171 type. A 201A is used in the first and second detector, in the oscillator, and the first two stages of audio. The 171 in the last stage, and the 199s in the intermediate stages. Despite the number of tubes used the plate current is not particularly heavy. With the proper voltages applied, the total current is about fifty milliamperes (180 volts on the 171 tube).

Please Mention Radio Age When Writing to Advertisers.



Exclusively Licensed by Technidyne Corporation Under U. S. Patent No. 1593658, July 27, 1926.

Have Music At Its Best!

"TONATROL"

A True Tone and Volume Control

To have music at its best—the tone clear and sweet—the correct volume is necessary.

With "Tonatrol" you can secure the proper volume instantly—with remarkable ease. Make your radio a greater joy by installing "Tonatrol" today.

Tonatrol—Standard Volume Control \$1.50.

Tonatrol—Type W. S. (with filament switch attached), \$2.00.

Write for free installation booklet for the proper way to control volume.

Dept. 42C, 175 Varick St., New York, N. Y.

ELECTRAD

Free

50-page Reference Book



Mailing List Catalog No. 55

POLK'S REFERENCE BOOK

FOR DIRECT MAIL ADVERTISERS

Shows how to increase your business by the use of Direct Mail Advertising. 50 pages full of vital business facts and figures. Who, where and how many prospects you have. Over 8,000 lines of business covered.

Write for your **FREE** copy.

R. L. POLK & CO., Detroit, Mich.
599 POLK DIRECTORY BUILDING
Branches in principal cities of U. S.

RADIO

ACCESSORIES
at **WHOLESALE**

BIG BARGAIN CATALOG

Radio Sets, "B" Eliminators, Chargers, Tubes, Kits, Parts—everything new in Radio at lowest wholesale prices. Thousands of nationally advertised bargains. All listed and illustrated in my Big New Catalog and **FREE** Cash Book.

132 Pages of valuable Radio information—trouble finding, set kind, building—Radio knowledge of all kinds. Write today. **HARRY SCHWARTZBERG PRES.**

AMERICAN AUTO & RADIO MFG. CO.
Dept. 134 American Radio Bldg.
Kansas City, Missouri

Station	Location	Kilo-Cycles	Meters	Power	Station	Location	Kilo-Cycles	Meters	Power
WCBS	Springfield, Ill.	1430	210	250	WSAX	Chicago, Ill.	1470	204	100
KSOO	Sioux Falls, S. D.	1430	210	250	WMBA	Newport, R. I.	1470	204	100
WLBY	Iron Mountain, Mich.	1430	210	50	WBBZ	Chicago, Ill.	1470	204	100
KFGQ	Boone, Iowa	1430	210	10	WHBL	Chicago, Ill.	1470	204	100
WTFI	Toccoa, Ga.	1430	210	250	WIBW	Chicago, Ill.	1470	204	100
KGHF	Pueblo, Colo.	1430	210	250	WMBH	Joplin, Mo.	1470	204	100
WRAF	LaPorte, Ind.	1440	208	100	WIBS	Elizabeth, N. J.	1470	204	250
WJBZ	Chicago Heights, Ill.	1440	208	100	WMBQ	Brooklyn, N. Y.	1470	204	100
WNBA	Forest Park, Ill.	1440	208	200	WLBX	Long Island City, N. Y.	1470	204	250
KFVD	Venice, Calif.	1440	208	250	KGFO	Terre Haute, Ind.	1470	204	100
KGFJ	Los Angeles, Calif.	1440	208	100	KGES	Central City, Nebr.	1470	204	10
WGM	Jennette, Pa.	1440	208	50	WKEN	Buffalo (Kenmore, N. Y.)	1470	204	250
WJPW	Ashtabula, Ohio.	1440	208	30	WOB	Shelby, Ohio.	1470	204	10
WMBE	St. Paul, Minn.	1440	208	10	KGGM	Inglewood, Calif.	1470	204	100
WLBZ	Dover, Maine.	1440	208	250	KGEQ	Minneapolis, Minn.	1470	204	50
WRPI	Terre Haute, Ind.	1440	208	100	WSVS	Buffalo, N. Y.	1470	204	50
KGCN	Concordia, Kans.	1440	208	50	KHAC	Portable on Aeroplane.	1470	204	50
KGCR	Brookings, S. D.	1440	208	15	WTFE	Mt. Vernon Hills, Va.	1480	203	10000
KGTT	San Francisco, Calif.	1450	207	50	KVL	Seattle, Wash.	1480	203	100
KLIT	Portland, Ore.	1450	207	10	WHBN	Gainesville, Fla.	1480	203	5000
WMRJ	Jamaica, N. J.	1450	207	10	WCBR	Providence, R. I.	1490	202	100
WTRL	Midland Park, N. J.	1450	207	15	WIBM	Chicago, Ill.	1490	202	100
WHPP	Bronx, N. Y.	1450	207	10	WIBJ	Chicago, Ill.	1490	202	100
WLBV	Mansfield, Ohio	1450	207	50	WIBM	Chicago, Ill.	1490	202	100
WNBK	Knoxville, Tenn.	1450	207	50	WKBG	Chicago, Ill.	1490	202	100
WNBF	Endicott, N. Y.	1450	207	50	WGMU	New York City, N. Y.	1490	202	100
KGDY	Oldham, S. D.	1450	207	15	WRMU	New York City, N. Y.	1490	202	100
KGGF	Picher, Okla.	1450	207	100	KGEY	Denver, Colo.	1490	202	250
WPSW	Philadelphia, Pa.	1450	207	50	WATT	Boston, Mass.	1490	202	100
KGDR	San Antonio, Tex.	1450	207	15	WALK	Willow Grove, Pa.	1490	202	50
WKBL	Monroe, Mich.	1460	205	15	KGEH	Eugene, Ore.	1490	202	50
WMBD	Peoria Heights, Ill.	1460	205	250	KWBS	Portland, Ore.	1500	200	15
WABF	Pringleboro, Pa.	1460	205	250	KUJ	Seattle, Wash.	1500	200	10
KGEO	Grand Island, Nebr.	1460	205	100	WNBL	Bloomington, Ill.	1500	200	15
KFXV	Flagstaff, Ariz.	1460	205	25	WKBB	Ludington, Mich.	1500	200	15
KGDE	Barrett, Minn.	1460	205	50	KGFN	Aneta, N. D.	1500	200	15
KGFF	Alva, Okla.	1460	205	25	WRAH	Providence, R. I.	1500	200	250
WRK	Hamilton, Ohio.	1460	205	100	WBMS	Union City, N. J.	1500	200	100
WOBT	Union City, Tenn.	1460	205	15	WNBW	Carbondale, Pa.	1500	200	5
WNBQ	Rochester, N. Y.	1460	205	15	WGOP	Flushing, N. Y.	1500	200	100
KFXD	Jerome, Idaho.	1470	204	15	WWRL	Woodside, N. Y.	1500	200	100
WLBN	Chicago, Ill.	1470	204	50	WBKN	Brooklyn, N. Y.	1500	200	100

Dominion of Canada

CFAC	Calgary Herald	Calgary, Alta.	434	CKCD	Vancouver Daily Province	Vancouver, B. C.	411
CFCA	Toronto Star Pub. & Prtg. Co.	Toronto, Ont.	356	CKCK	Leader Pub. Co.	Regina, Sask.	312
CFCF	Marconi Wireless Teleg. Co., (Ltd.)	Ca. Mont., Que.	411	CKCL	Dominion Battery Co.	Toronto	360
CFCH	Abitibi Power & Paper Co. (Ltd.)	Iroquois Falls, Ont.	500	CKCO	Ottawa Radio Association	Ottawa, Ont.	434
CFCK	Radio Supply Co.	Edmonton, Alta.	517	CKCX	Int'l Bible Students Ass'n.	Toronto	291
CFCN	W. W. Grant (Ltd.)	Calgary, Alta.	434	CKFC	First Congregational Church	Vancouver, B. C.	411
CFCR	Laurentide Air Service	Sudbury, Ont.	410	CKLC	The Alberta Pacific Grain Co. (Ltd.)	Red Deer, Alta.	357
CFQC	The Electric Shop (Ltd.)	Saskatoon, Sask.	329	CKNC	Canadian National Carbon Co.	Toronto, Ont.	357
CFRC	Queens University	Kingston, Ont.	268	CKOC	Wentworth Radio Supply Co.	Hamilton, Ont.	341
CFXC	Westminster Trust Co.	Westminster, B. C.	291	CKY	Manitoba Tel. System	Winnipeg, Man.	384
CFYC	Commercial Radio (Ltd.)	Vancouver, B. C.	411	CNRA	Canadian National Railways	Moncton, N. B.	322
CHCS	The Hamilton Spectator	Hamilton, Ont.	341	CNRC	Canadian National Railways	Calgary, Alta.	435
CHIC	Northern Electric Co.	Toronto, Ont.	357	CNRE	Canadian National Railways	Edmonton, Alta.	517
CHNC	Toronto Radio Research Society	Toronto, Ont.	357	CNRM	Canadian National Railways	Montreal, Que.	411
CHUC	International Bible Ass'n.	Saskatoon, Sask.	329	CNRO	Canadian National Railways	Ottawa, Ont.	434
CHXC	R. Booth, Jr.	Ottawa, Ont.	434	CNRQ	Canadian National Railways	Quebec, Que.	341
CHYC	Northern Electric Co.	Montreal, Que.	411	CNRR	Canadian National Railways	Regina, Sask.	312
CJCA	Edmonton Journal	Edmonton, Alta.	517	CNRS	Canadian National Railways	Saskatoon, Sask.	329
CJCR	N. Am. Colliers (Ltd.)	Evansburg, Alta.	357	CNRT	Canadian National Railways	Toronto, Ont.	357
CJGC	London Free Press	London, Ont.	326	CNRV	Canadian National Railways	Vancouver, B. C.	291
CKAC	La Presse	Montreal, Que.	411	CNRW	Canadian National Railways	Winnipeg, Man.	405

A Compact, Correct Call Book

The foregoing list of American broadcasting stations includes kilocycles, wave-lengths by meters and the power each station is authorized to use. Despite difficulty in keeping pace with frequent changes in the station list readers will find this to be 100 per cent accurate as of date, December 1, 1927, the latest official information obtainable on December 20, 1927.

The biggest Edition—

The biggest edition ever published. Brimful of soundest information, latest circuits and hook-ups, new revised list of world's broadcasting stations with schedules and new wave lengths in meters and kilocycles. 264 pages of news, ideas, and valuable information for fans, set builders, radio dealers and everyone interested in radio's advancement.

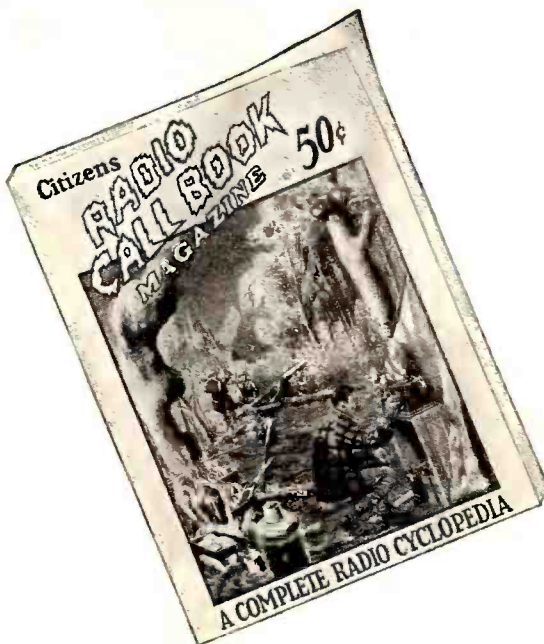

Citizens Radio Call Book Magazine

November, 1927, Edition

Now on Sale at Newsstands and Radio Stores

First with the Latest

All receivers designed and tested in our laboratories

Complete constructional details on the newest radio circuits are given and include the Camfield Shielded Grid Seven Receiver using radio's latest tube development, Magnaformer 9-8 A. C. Super, R. G. S. Octamonic Receiver, Madison-Moore International "One-Spot," Thordarson Power Amplifier System, Three Foot Cone Speaker construction article, Silver-Marshall Laboratory A. C. Shielded Super, Victoreen, Tyrman Ten, World's Record Eight, Knickerbocker Four and many other interesting circuit arrangements for experimenters and professional set builders.

Wonderful Rotogravure Section

One of the big features of the new Call Book is the 16-page rotogravure section. It is replete with photographs and views. Your favorite radio artists, pictures of studio life, prominent announcers and other features are shown in actual photographic views.

A Complete Radio Cyclopedia

Be sure that you get the CITIZENS RADIO CALL BOOK MAGAZINE, the original and most widely circulated publication of its kind. Accept no substitutes. Published four times yearly, September, November, January and March. On sale at newsstands and radio stores the world over, or subscribe now and be sure of receiving each issue as published.

Use the handy coupon below.

Mail
This →
Coupon
Today!

CITIZENS RADIO SERVICE BUREAU, Inc., Publishers
508 South Dearborn St., Chicago, Ill., Dept. R, U. S. A.

(RA)

Date.....192.....

Please enter my subscription for the CITIZENS RADIO CALL BOOK MAGAZINE for [] one year, \$1.75; [] two years, \$3.25; [] three years, \$4.50.

Enclosed please find in payment for same, mailed postpaid four times yearly, January, March, September and November. Canada and Foreign, \$2.00 yearly.

Name.....

Address.....

City.....

State.....

CLASSIFIED ADVERTISEMENTS

If you have anything to buy or sell, don't overlook RADIO AGE'S classified advertisements.

The classified advertising rates are but four cents per word for a single insertion. Liberal discounts are allowed on six and twelve-time insertions, making rate of 3 and 2 cents a word per insertion respectively. Unless placed through an accredited advertising agency, cash should accompany all orders. Name and address must be included at foregoing rates. Minimum contract charge \$1.00.

All Classified ads for February issue must be sent in by Jan. 1.

AGENTS

RADIO AGENTS—Make Big Money—Easy selling Marvelous New Sets and Accessories. Buy from factory at lowest prices. Get New Catalog with thousands of nationally advertised bargains. FREE Call Book. Write today. American Auto and Radio Co., Dept. 135, American Radio Bldg., Kansas City, Mo.

AIRPLANES

SEND FOR free illustrations and plans of our wonderful two-piece, compass type, small, high lift wing monoplane, and information on how to build this airplane. Be sure it will fly; also propeller literature. Crawford Airplane Manufacturing, 2225 American Avenue, Long Beach, California.

BOOKS AND MAGAZINES

Twentieth Century Book of Receipts, Formulas and Processes, a 307 cloth bound book containing 10,000 proven formulas for the manufacturer, workshop, laboratory, office and home. Sent prepaid upon receipt of \$4.00. Send dime for our 48 page catalog of latest and best practical, scientific mechanical and industrial books. Midland Products Co., Dept. RA, 524 Courtland Ave., Park Ridge, Ill.

BOYS

Boys get a three feet model airplane free. No selling. Write for particulars. Aero Shop, 3050 Huribut Ave., Detroit, Michigan.

RADIO SET FREE, form magazine clubs among friends. Club list free. Spencerian Agencies, Los Angeles, Brentwood Heights, California.

BUSINESS OPPORTUNITIES

PECAN-Orange-Flg Groves "On the Gulf". Monthly payments. Guaranteed care. Big, quick returns. Suburban Orchards, Dept. R, Biloxi, Mississippi.

LAND FREE if planted to bananas. Bananas bear a full crop the second year. \$5.00 monthly will plant five acres, which should pay \$1,500 profit annually. Reliable Companies will cultivate and market your bananas for 1-3. Bananas ripen every day and you get your check every 90 days. For particulars address Jantha Plantation Co., Empire Building, Block 980, Pittsburgh, Pa.

DETECTIVES

BE A DETECTIVE. Make secret investigations. Earn big money. Work home or travel. Fascinating work. Excellent opportunity. Experience unnecessary. Particulars free. Write American Detective System, 2199 Broadway, New York.

DOGS

BEAUTIFUL REGISTERED BULL PUPS \$18. Bulldog, 501 Rookwood, Dallas, Texas.

ELECTRICAL

ELECTRIC FUNI Seventy stunts, 110 volts, \$1. Courtland, Campbell, Calif.

FORMULAS

200—Any Formula, 20c. "Hawkins," 215R Las Animas, Colorado Springs, Colorado.

MALE HELP WANTED

MEN, get Forest Ranger job: \$125-\$200 mo. and home furnished; Government hunt, fish, trap. For details, write Norton, 259 Temple Court, Denver, Colo.

MISCELLANEOUS

NEUTRODYNE AND HETERODYNE ARE GOOD AS FAR AS THEY GO. THE BEST ONE TUBE SET FOR PYORRHEA IS ZI-O-DINE (tooth-paste). **SATISFACTION GUARANTEED. FIFTY CENT TUBES BY MAIL. IODINE PRODUCTS COMPANY, LAUREL, MISS.**

GILLETTE STYLE Razor with 10 Blades 60c Prepaid. Loud Speaker \$3.89. Speaker Unit \$1.10 prepaid. Transformer 25c. Melo Station A, New Haven, Conn.

MUSIC COMPOSED to words, Broadway Music Writers, Inc., 1476 Broadway, G. C. P. O., Box 414, New York, N. Y.

PANEL ENGRAVING

SINGLE PANEL and medium quantity engraving of highest quality. Also panel drilling, meter cutouts and machine engraving on small parts. Careful attention to single panels and special work. Write for price-list. A. L. Woody, 19 S. Wells Street, Chicago.

PERSONAL

Spirit life proved through method lost during European Dark Ages. Free description. R. C. Hill, 602 W. Jefferson, Detroit, Mich.

RADIO

EXTRA HEAVY Antenna wire 7 No. 18 \$1.50 100 feet. 17 No. 22 braided 3-8" wide \$2.00 100 feet all prepaid. Geo. Schulz, Calumet, Michigan.

Radio set builders send for our new wholesale catalog. It's free. Kansas City Radio Company, Kansas City, Mo.

Radio Books—Construction of a modern Super Heterodyne Type Receiver including Testing and Operation \$1.00; Healey's 222 Radio Circuit Designs, 267 pages, \$1.00; The ABC of Vacuum Tubes used in Radio Reception 132 pages, 75 cents; Healey's Workable Radio Receivers 198 pages \$1.00; Experimental Wireless Stations 332 pages \$2.00; Wireless Telegraphy and Telephony Simply Explained 154 pages \$1.00. Sent prepaid on receipt of price. Send dime for our 48 page catalog of latest and best practical, scientific, mechanical and industrial books. Midland Products Co., Dept. RA, 524 Courtland Ave., Park Ridge, Illinois.

SILICON Transformer Steel cut to order .014", 10 lbs. 25 cents, 5 lbs. 30 cents, less than 5 lbs. 35 cents per lb., 4 cubic inches to the lb. postage extra. At least 1/2 cent with order—balance C. O. D. Geo. Schulz, Calumet, Michigan.

Mr. H. Sedwick, 1653 Addison St., Chicago, Ill., writes to us as follows: "I bought one of your Radio Trouble-Shooters. Just the thing I have been looking for." It's new list price is only \$3.00. Write for new catalog. Metropolitan Mfg. & Elec. Co., 1163 Sedgwick St., Chicago, Ill., Dept. C.

EDISON "A" BATTERIES—3 cell, 20 ampere hour, in neat metal cases. Price \$3.50 each, ten or more \$3.00 each Cash with order, Department B, 25 East South Street, Indianapolis, Indiana.

Set Builders. We furnish jobs. No fee. Register now on our list of professional set-builders. Inquiries from your locality will be referred to you. We are headquarters for parts of Hammarlund-Reberts, Silver Shielded Six, Karas Equamette, Bremer-Tully Power Six, Harkness Counterparts and other popular circuits. Regular at once. Give references and experience. Allen Rogers-Madison, Inc., Dept. A, 35 West 51st Street, New York, N. Y.

Choke cells with adjustable cores take out the guess work in your filter system. 30 to 100 Henry 150 M. A. \$5.75. Transformers 650 volts \$7.25, 550—\$3.50, low voltage to specifications \$4.50. Write for lists of eliminator kits and parts, also meters, etc. Radio Parts Sales Co., Orange, N. J.

600-MILE RADIO. \$2.95 postpaid. Needs no tubes, batteries, or electrical current. Over 300,000 homes have them. Picture and folder sent free. National Radio Sales Co., Fuller Bldg., Wichita, Kansas.

Transformers 100 watt 650 & 7 1/2 volts \$7.25—550 volts for Raytheon \$3.50. Chokes—30H—150 MA \$5.75, 50H—100 MA \$2.50, 30H—60MA \$2.25, 20H—30MA \$1.00. Raytheon parts \$18.75—Write for lists. Radio Parts Sales Co., Orange, N. J.

PURE ALUMINUM and lead rectifier elements, bolts drilled, with brass screws and nuts per pair 1-18", 1"x4", 1 1/2", 1x8, 1 1/2", 1 1/2"x8, 1 1/2", 1 1/2"x8, 1 1/2", single elements half price. Sheet aluminum 1-18", \$1.00, 1-8" \$1.90. Lead \$1.00 square foot nil prepaid. Geo. Schulz, Calumet, Michigan.

For Sale: One improved "Aero" regenerative kit for .00035 condensers. Price \$5.00. Also the following straight line frequency condensers, two Bremer-Tully .00035 condensers, price \$3.00 each, one DeJur .00035 condenser, price \$2.00, one Amasa .0005 condenser, price \$2.00, two Challen midjet condensers \$1.00 each, one set of Browning-Drake cells, price \$2.50, one All-American self tuned radio frequency transformer, price \$2.00, one "Aero" antenna coupler, price \$2.50. Earn Fry, P. O. Box 187, Earlham, Iowa.

For Sale at Half Price. 5 201A Amperites, 1 pr. Benjamin brackets, 2 Claretats, 1 Frost 28 ohm rheostat 1.5 Ampere Variable condensers, 1 .00035 mid 4 .0005 mid, 8 Dubilier 1. mid bypass condensers, 1 Frost push pull switch, 1 Carter Imp 50 ohm rheostat, 1 Frost double circuit jack, 2 Jefferson Concertone Transformers, 2 Bruce cell forms. Some parts are slightly used, others are new. Z. Grablewski, 9 N. Market St., Nanticoke, Pa.

LOG-CHART UR RADIO by the newest, simplest and easiest way. Absolutely no writing—A MERE DOT locates that station as received on ur radio in respect to Call Letters, wave length and dial reading. Stations from all parts of the world; includes outline map of the United States. Priced 25c. Radio Laboratory, 505 Madison Square Bldg., Chicago or 229 Whittemore Pontiac, Michigan.

UX226 and UY227 A. C. filament transformers \$3.50. Low voltage transformers to your specifications \$4.50. 50H 85MA chokes \$2.50, 100H 125MA heavy duty chokes \$5.75. See our new lists on meters condensers, eliminator parts, etc. Radio Parts Sales Co., Orange, N. J.

600-MILE RADIO. \$2.95 postpaid. Needs no tubes, batteries, or electrical current. Over 300,000 homes have them. Picture and folder sent free. National Radio Sales Co., Fuller Bldg., Wichita, Kansas.

Radio repairing and building. Write for information. Radio, Box 92, Oakhill, West Virginia.

RUBBER STAMPS

RUBBER STAMPS and supplies. 20c per line. Cushion Mounted. Catalog for stamp. Newman & Son, Auburn, Nebraska.

RUBBER STAMPS Name, Address, two lines 25c. Three Lines 35c. C. Brush Company, Auburn, Nebraska.

SALESMEN WANTED

Salesmen—Calling on the radio trade to sell ORTHO-CONE speakers—nationally famed for their wonderful tonal qualities. Low price, liberal discounts to dealers. Big commissions. An unusual money-making opportunity for you. Sample furnished. References required. Write immediately to Orthocone Speaker Company, 2728 St. George Court, Chicago, Ill.

75 MILES ON 1 GALLON—New Moisture Gas Saver. All Cars. 1 Free. CRITCHLOW, A2-91, Wheaton, Ill.

Radio Age Classified Ads Bring Results

Better . . . than it looks

Some radio sets are all Queen Ann in front and plain Mary Ann when you lift the lid. A beautiful finish—to please the wife—is more important than quality in the actual working parts. And some circuits are sweet performers when it comes to radio reception but they certainly look like a junk-shop product when you have a party of critical friends in for the evening. But here is a set . . . well, just look at it. And then remember that its performance is even better than its appearance. Yes, of course, it's the

1928 Infradyne

This is a circuit which is never sold as a factory product. It can't be. But that does not mean that you have to work for weeks in building it up from small unmatched parts. Just buy four Remler units, a few extra parts, and in a few hours your Infradyne will give you the finest reception you—or anyone else—ever enjoyed.

Use the coupon below.

REMLER
Division of

Gray & Danielson Mfg. Co.

260 First Street, SAN FRANCISCO

CHICAGO

NEW YORK

Eastern Warehouse, Elkhart, Indiana



Dept. A

REMLER DIVISION, GRAY & DANIELSON MANUFACTURING CO.
260 First Street, San Francisco, Calif.

Please send me complete information about the Infradyne and folder describing all Remler Parts.

Name.....Street.....City.....

Do you build and sell sets?

Amazing *New* A C radio tubes eliminate batteries by use of electric house current

NEW RADIO TUBES TO USE ORDINARY HOUSE CURRENT FOR POWER

NEW YORK, Jan. 3rd.—Much interest was aroused in radio circles today by the announcement that a radio tube had at last been perfected which used ordinary electric house current in the operation of its plates.

ELECTRICAL WIZARD RUNS RADIO WITH ORDINARY HOUSE LIGHTING CURRENT

—A radio receiver...

NEW RADIO TUBE WILL OBSOLETE BATTERY POWER

WASHINGTON, Mar. 5.—Those who from the earliest days have waited for a work "from" now...

in the **CROSLLEY AC BANDBOX** 6 tubes Genuine Neutrodyne



STORIES in regard to the coming of AC tubes which would operate from house-lighting circuits appeared in various newspapers last spring, bringing to a climax great anticipation in the public mind.

With the acquisition of a license by The Crosley Radio Corporation under a large group of patents controlled by The Radio Corporation of America, American Telephone and Telegraph Company, General Electric Company, Westinghouse Electric and Manufacturing Company, etc., the Crosley AC Bandbox is possible through the use of the new R. C. A. alternating current tubes, UX226 and UY227. These tubes utilize for their filaments and heating regular alternating current from the house-lighting circuit.

The current is stepped down by means of a transformer without need of rectifiers to supply the heat necessary for the functioning of the tubes.

Now
\$110
without tubes

The converter box, which is included with the Crosley AC Bandbox can be tucked away out of sight. It is connected to the Bandbox by a cable and also supplies the current for the plate voltages on the tubes replacing B batteries.

Thus the Crosley AC Bandbox functions entirely from the regular house-lighting current without need of batteries, battery chargers, or any of the other usual paraphernalia which requires attention, care and early replacement. The Crosley AC Bandbox with the new alternating current tubes is truly revolutionary, and brings to the radio user an entirely new conception of care-free radio entertainment of the highest standard of performance.

The Crosley BANDBOX is the country's most talked of radio! The popularity centers around two major factors:

1. The imposing array of patents under which it is built.
2. The number and quality of the features Powell Crosley, Jr., has built in it for the price!

—And what value Crosley has added to the imposing engineering talent behind the BANDBOX!

1. Complete shielding of all elements.
2. Absolute balance (genuine Neutrodyne).
3. Volume control.
4. Accumulators for sharpest tuning.
5. Single cable connections.
6. Single station selector.
7. Illuminated dial.
8. Adaptability to ANY type installation.

Today's radio must be adaptable to the home. It must fit into all kinds of conditions. Perhaps you have a bookcase corner—a desk compartment—a chest—or even a bureau drawer where it could be tucked away. Maybe you want it to be part of the furnishings, as an impressive console or credenza cabinet. The Bandbox fits in everywhere.

The metal outside case is easily and quickly removed. The set is solidly mounted on a stout steel chassis. As all controls are assembled together in the front, cabinet panels are easily cut to allow their protrusion. The metal enclosure is screwed on over the shafts and the installation has all the appearance of being built to order.

Two large furniture manufacturers have designed console cabinets in which the Bandbox can be superbly installed.

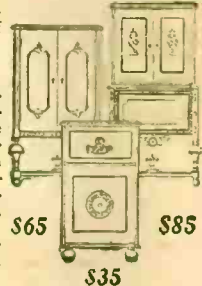

Shamers Bros. \$65
Co. of Bloomington, Indiana, and Wolf Mfg. Inc. of Kokomo, Indiana. \$85
\$35

(Shamers Bros., Co. of Bloomington, Indiana, and Wolf Mfg. Inc. of Kokomo, Indiana.) Powell Crosley, Jr., has approved them mechanically and acoustically and has seen to it that the famous Crosley Musicones are built in them so that the best type of loud speaker reproduction may be insured. This is the kind of radio you have been waiting for—the real direct electric set that requires absolutely no attention. What if it does run all night! Who cares? No run down batteries greet you in the morning. You owe it to yourself to see the Bandbox and listen to its remarkable performance. If you cannot easily locate the nearest Crosley dealer, his name and address will be supplied on request. Write Dept. 63.

Montana, Wyoming, Colorado, New Mexico and West, prices slightly higher

CROSLLEY RADIO

THE CROSLLEY RADIO CORP.
Powell Crosley, Jr., Pres.
Cincinnati, Ohio

"You're there with a Crosley"

Crosley is licensed only for Radio Amateur, Experimental and Broadcast Reception.