



AM/FM STEREO RECEIVER model R600

LUXMAN 600

SERVICE MANUAL

R600 CIRCUIT DESCRIPTION

Power Supply

The mains input to the receiver goes via 2 pole power switch to the mains transformer which has two secondary windings:

- 1) A 7-volt winding for the panel lamps.
- 2) A 50-0-50 volt winding to provide 55-volt DC for the audio power amp, pre-amp and tuner sections.

The Q608 (2SC1509) transistor is used as a ripple filter providing 43-volt to the pre-amp section and the Q610 (2SC1509) transistor is used as part of the over load protection as well as a ripple filter for the early stage of the power amp at the voltage of 52-volt. A potential divider using a zenor diode is used to obtain from 55-volt a 12-volt DC supply for AM and FM tuner sections. There are fuses in the secondaries for transformer protection.

POWER AMPS

The circuit is basically a 6 transistor direct coupled quasi complementary design, since only one power supply voltage with respect to ground is used, the audio from the proceeding pre-amp tone control stages is capacitor coupled to the base of the first PNP transistor, this base is also biased to approximately half supply volts so therefore is used as a reference to set the output stage to half supply, D.C. negative feedback from the output is applied to the emitter, so that the base and emitter form a simple type of voltage comparitor.

The collector is coupled to the base of the second transistor which is the voltage driver for the power transistor emitter followers.

Two NPN transistors form the positive power emitter followers and a PNP, NPN compound form the negative power emitter followers. Their bases are biased by a 2 diode device (SV-02) and a bias trim pot to set the output idling current at 35mA.

The output from the junction of these four transistors is coupled by a 2200 μ F condenser to the loudspeaker terminals. A condenser and two resistors form a bootstrap constant current collector load for the voltage amplifier transistor.

Overall AC feed back is taken from the loud speaker side of the output condenser and applied back to the emitter of the first transistor.

Audio is also taken from the speaker side of the condenser via a 470 ohms resistor to the headphone socket.

PRE AMP

The RIAA amplifier uses an NPN and PNP direct coupled pair of transistors which are selected low noise types, the equalization and DC feedback are taken from the collector of the PNP back to the emitter of the input NPN transistor. This amp has a gain of 36 db (2.5 mV – 150 mV) at 1 KHz. The linearity of this direct coupled combination offers high overload capabilities (100 mV at 1 KHz). The 150 mV. nominal level is at the same level as the other functions. The Function Switch selects AM, FM, AUX and Phono. This audio then goes to the tape monitoring function switches.

The Tape Monitor Switch allows selection of either the direct programme source as selected by the Function Selector or play back from a tape recorder, if the tape recorder has a three head configuration, then in the monitor position it is possible to compare the recorded signal with the direct signal almost immediately.

The required selection will then go to the 2 transistor NPN, PNP direct coupled flat response amp which drive succeeding tone control circuit with low impedance. A NPN transistor is used in a Baxandale-type active bass and treble control, operating in a virtual earth mode with the input audio at the boost point of the controls and the base of the transistor fed from the slider of the bass control via C908, the collector being the feedback point to the controls and providing the output which is at unity gain with respect to the input to drive the filters and the power amplifier. The filters are constructed by CR type 6 db/oct hi and low cut filters with hi cut 7 KHz and off, and low cut 70 Hz and off.

AM SECTION

A superhet design incorporates an integrated circuit for all stages, eg, the mixer, local oscillator and two stages of IF amplification, the IF being 455 KHz. A ferrite rod antenna with three winding is used, the first winding is connected to the External Antenna Terminal, the second to the first section of two gang tuning condenser, the last winding then feeds the input of the I.C.. The I.C. which includes all the necessary stages produces an audio signal at its output suitable for directly feeding the Function Selector.

FM SECTION

The front end has a three gang tuning capacitor and consists of a dual gate MOS FET for the tuned RF amp, which feeds via a tuned transformer, the dual gate MOS FET mixer.

A bipolar transistor "Colpitts" oscillator operates at 10.7 MHz above the incoming signal. C112-C114 are negative temperature coefficient condensers to stabilize the oscillator to less than 25KHz per 10 deg. Celsius.

The output is then fed to the gate of the mixer, the resultant 10.7 MHz passes through a single tuned IFT. The front end is well shielded to prevent any spurious radiation, and to offer good image and selectivity responses.

IF and MPX

The IF strip is contained on the same printed board as the front end, the stereo multiplex decoder and muting circuit.

Output signal from front end goes through two stages of ceramic filters and transistor amplifiers. Then the 10.7 MHz signal is amplified and limited by integrated circuit (IC201) which contains three stage amplifiers and two stage differential amplifiers. A differential circuit with a built-in constant current source provides full limiting, this goes to the discriminator which provides the composite audio output for multiplex. The collector of the second IF transistor provides the signal for the AGC and tuning meter.

A single transistor is used to provide muting control circuitry and an output which is combined with the signal from the AGC to drive the meter.

At the audio output, when the receiver is off-tuned from centre, either a positive or negative DC will appear which is monitored by a bi-phase detector using two NPN transistor which with another NPN forms an "AND" gate for a trigger circuit inclosed in the multiplex IC and muting circuit.

The composite audio passes on to the IC multiplex, which will derive to the L and R audio output. The IC also is connected directly to the stereo indicator lamp. The Left and Right go through LC type rejection filters to remove the 19 KHz pilot.

Finally, a one transistor amplifier is used in each channel to raise the level to 600 mv for the audio pre amp. A de-emphasis switch has been incorporated on the chassis for selecting either 75 μ sec or 50 μ sec time constant.

R600 ALIGNMENT PROCEDURE

The alignment procedure described in each chart may be performed independently, without affecting the others. Warm up the signal generators for at least 15 minutes to make certain that they are stabilized at their operating temperature particularly generators containing vacuum tubes. Consult the instruction manual supplied with the particular test instrument for specific information concerning connection and operation.

The test equipment listed here is intended only as a guide, but alternate instruments should be of similar quality.

The following instruments are required for a complete alignment of the tuner.

1. Measurement instruments and tools

Signal source	1) FM signal generator (FMSG) 2) Sweep generator (SWG) 3) AM signal generator (AMSG) 4) FM stereo modulator (MPXSG) 5) Audio oscillator (AFO) 10 - 100KHz 0.2% accuracy, Dist. 0.1%	Meguro MSG-285A or equivalent JRC NJM-5217C or equivalent Meguro MSG-221C or equivalent Sound technology-1000A or equivalent Oscillation freq. range 10 - 100,000Hz, calibration error within 0.2%, distortion 0.1%
Output indicator	6) AM standard loop antenna 7) Oscilloscope (CRO) Mid bandwidth 5MHz 8) Distortion meter (HDM) 9) AC volt meter (ACVTVM) 10) DC volt meter (DCVTVM)	Meguro MLA-1001B or equivalent Iwatsu SS-5057V or equivalent Shibaden CR-6S or equivalent Kikusui 164 or equivalent Kikusui 107A or equivalent
Tools	11) Hex head alignment tool 12) Thin plastic shaft alignment tool	

2. General alignment conditions

- 1) The normal test voltage is within 10% of what is indicated on the receiver with less than 2% harmonic distortion.
- 2) Unless otherwise specified, the normal ambient temperature is 15-25°C and humidity 55-75%. But if this is not possible, 5-35°C, 45-85% will provide acceptable results.
- 3) FM dummy antenna shall be as follows if not otherwise specified. The output voltage of the signal generator is 1/4 of the unloaded terminal voltage.

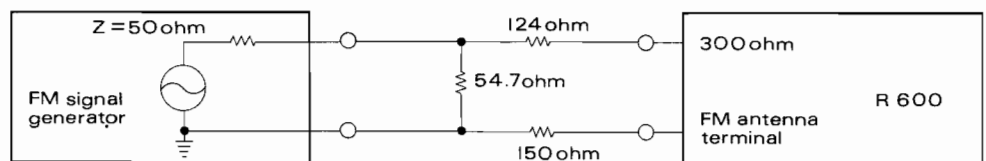

- 4) Connect the low side of signal source and the output indicator to the chassis ground as close as possible to the high side connection unless otherwise specified.
- 5) The 10.7MHz marker used in each section of the alignment should be the same.
- 6) Marker insertion and amplitude should not distort the oscilloscope trace.
- 7) The AM standard loop antenna should be set above the ferrite loopstick antenna.
- 8) The output level of the sweep generator is measured by the output attenuator regardless of its terminated impedance.
- 9) FM modulation is 100% with ± 75 KHz.
- 10) All tuner audio output measurement are at REC. OUT.

Step	Signal Source Connected to	Set signal to	Set Radio Dial to	Output Indicator Connected to	Adjust	Adjust for	
1	Set selector switch to "FM", muting switch to "off", and turn power switch "on".						
2				DC VTVM P.C.B. #0.023 (24)		Check that voltage is between 11.4 ~ 12.6V	
3				Refer circuit diagram		Check each part voltage if necessary	
4	Sweep generator P.C.B. #0023 T.P.	±400KHz sweep centred at 10.7MHz generator output level 90-100dB	Quiet point on band	Oscilloscope P.C.B. #0023 CP-1		Due to the fixed frequency of the ceramic filters, find the centre frequency of a symmetrical band pass response. Make a note of it (for example 10.75MHz)	
5				Oscilloscope P.C.B. #0023 CP-1	T101 core	Symmetrical response centred at the frequency noted by step 4	
6				Oscilloscope P.C.B. #0023 CP-2	T202 core		
7				Oscilloscope P.C.B. #0023 CP-3	T201 top core T201 bottom core	Maximum linearity and amplitude of "S" curve centred at the frequency noted by step 4	
8	FM signal generator Across FM antenna terminals (300Ω) through matching network	Reduce the output level to zero (interstation receiving condition)	93MHz	DC VTVM P.C.B. #0023 CP-3	T201 top core	Zero volt	
9		93MHz at 400Hz 100% modulation, output level 1mV		Oscilloscope Distortion meter AC VTVM REC OUT	T201 bottom core	Minimum distortion. At the minimum distortion setting, the output level must be within 1/2dB of peak output.	
10	Repeat steps 8 and 9 as necessary to obtain maximum output level and minimum distortion at maximum point of tuning meter and the meter must also shows minimum at interstation state.						
11	FM signal generator Across FM antenna terminals (300Ω) through matching network	88MHz at 400Hz 100% modulation, generator output level 1mV	88MHz	Oscilloscope Distortion meter AC VTVM REC OUT	L103	Accurate indication of pointer on dial to within ±1 pointer width	
12		108MHz at 400Hz 100% modulation, generator output level 1mV	108MHz		TC103		
13		88MHz at 400Hz 100% modulation, generator output level 5 ~ 10μV	88MHz			T101 core	Maximum indication of signal strength meter
14						L101	

Step	Signal Source Connected to	Set signal to	Set Radio Dial to	Output Indicator Connected to	Adjust	Adjust for
15	FM signal generator Across FM antenna terminals (300Ω) through matching network	88MHz at 400Hz 100% modulation, generator output level 5 ~ 10μV	88MHz	Oscilloscope Distortion meter <u>AC VTVM</u> REC OUT	L102	Maximum indication of signal strength meter
16		108MHz at 400Hz 100% modulation, generator output level 5 ~ 10μV	108MHz		TC101	
17					TC102	
18	Repeat steps 11 ~ 17 as necessary to obtain correct tuning on dial scale and the maximum indication of signal meter with uniform sensitivity throughout the band					
19	FM signal generator Across FM antenna terminals (300Ω) through matching network	93MHz at 400Hz 100% modulation, output level 1mV	93MHz	Oscilloscope Distortion meter <u>AC VTVM</u> REC OUT	T201 bottom core	Minimum distortion. At the minimum distortion setting, the output level must be within 1/2dB of peak output.
20		88MHz at 400Hz 100% modulation	88MHz			
21		108MHz at 400Hz 100% modulation	108MHz			
22		98MHz at 400Hz 100% modulation output level 7μV	98MHz		VR201	Swing of signal strength meter to first indicator mark or if not possible ±1/2 is acceptable
23	Set muting switch "on"					
24	FM signal generator Across FM antenna terminals (300Ω) through matching network	98MHz at 400Hz 100% modulation generator output level 7μV	98MHz	Oscilloscope <u>AC VTVM</u> REC OUT	VR202	Fix VR202 at the point where output signals appear (muting adjustment)
25		98MHz at 19KHz 3 ~ 4% modulation generator output level 1mV			<u>Oscilloscope</u> IC301 ①	L301 core
26	FM signal generator Across FM antenna terminals (300Ω) through matching network	98MHz at 19KHz 10% (L-R) 400Hz 45% output level 1mV	98MHz	Oscilloscope <u>AC VTVM</u> REC OUT	L302 core	To obtain peak output voltage
27		98MHz at 19KHz 10% L (or R) stereo 90% modulation output level 1mV			VR301	Maximum separation
28	Repeat steps 25 ~ 27 as necessary to obtain maximum separation both L and R channel					

Step	Signal Source Connected to	Set signal to	Set Radio Dial to	Output Indicator Connected to	Adjust	Adjust for
29	Set selector switch to "AM"					
30	Sweep generator P.C.B.#0023 19 through 1 μ F mylar capacitor	\pm 20 ~ 25KHz sweep centred at 455KHz generator output level 3mV	Quiet point on band near 600KHz	Oscilloscope P.C.B.#0023 CP-4	T401 red core	Maximum symmetrical response with flat top Do not adjust for two humps
31					T401 blue core	
32					T402 black core	
33	Adjust VR401 and VR402 to mechanical center position					
34	AM signal generator Standard radiating loop antenna placed near AM built in antenna	600KHz at 400Hz 30% modulation, field strength 50dB/m	600KHz	Oscilloscope AC VTVM REC OUT	L401 core	Accurate indication of pointer on dial to within \pm 1 pointer width
35					L1 core	Maximum reading on AC VTVM
36		1400KHz at 400Hz 30% modulation, field strength 50dB/m	1400KHz		TC402	Accurate indication of pointer on dial to within \pm 1 pointer width
37					TC401	Maximum reading on AC VTVM
38	Repeat steps 34 ~ 37 as necessary to obtain exact tuning on dial scale and maximum sensitivity					
39	AM signal generator Standard radiating loop antenna placed near AM bar antenna	1000KHz at 400Hz 30% modulation, field strength 45dB/m	1000KHz	Oscilloscope AC VTVM REC OUT	VR401	Audio output level should be 95mV
40		1000KHz at 400Hz 30% modulation, field strength 74dB/m			VR402	Adjust to read 60 ~ 80% of full scale of meter

SEMICONDUCTOR SPECIFIC CHART

TRANSISTORS (Ta=25°C)

TYPE	MAX. RATING			CHARACTERISTICS											
	Pc	Vceo	Ic	hfe				fT MHz			NF				
	W	V	mA	min	max	IcmA	Vce V	typ	Ic mA	Vce V	max dB	Ic mA	Vce V	fre Hz	Zg Ω
2SA640F	0.25	50	50	225	450	0.5	3	100	1	6	4	0.3	6	100	10K
2SA763-WL5	0.2	50	50	250	500	1	6	120	1	6					
2SA777R	0.75	80	500	130	220	150	10	120	50	10					
2SC710C	0.2	25	30	55	110	1	6	200	1	6					
2SC711F	0.2	25	100	250	500	1	6	150	1	6					
2SC945P	0.25	50	100	200	400	1	6	300	1	6	20	0.3	6	100	10K
2SC1000BL	0.2	50	100	350	700	2	6	80	1	6	2	0.1	6	100	10K
2SC1030B	50.0	80	6000	60	120	1000	5	10	1000	5					
2SC1345E	0.2	50	100	400	800	2	12	230	2	12	1	0.1	6	1K	10K
2SC1509R	0.75	80	500	130	220	150	10	120	50	10					
2SC1539	0.15	20	30	120	1200	0.5	3	200	10	5					

FIELD EFFECT TRANSISTOR (Ta=25°C)

	MAX. RATING			CHARACTERISTICS							
	PT	VDS	ID	IDSS		mA	Crss	pF	NF		
	mW	V	mA	min	max	Vds V		Vds V	typ	Vds V	
3SK45B, C	330	22	35	11	32	15	0.03	15	2.2	15	

DIODES (Ta=25°C)

TYPE	MAX. RATING			CHARACTERISTICS			
	If	Vr	Surge	If		Ir	
	A	V	A	mA	Vf V	μA	Vr V
IN60P	0.05	-35	0.5	0.004	1	30	-10
IN60AMZ	0.05	-30	0.5	0.015	1	75	-10
KB169	0.05	-3		3	0.7	10	-3
IS188AM	0.05	-35	0.5	4	1	75	-10
IS2473	0.11	-35	0.4	100	1.2	0.5	-35
VO3C	1.1	-200	30				
BZ-120				20	13	10	-10
BZ-140				20	14	10	-11

INTEGRATED CIRCUIT SPECIFIC CHART

AN277

MAXIMUM LIMITS OF DEVICE (Ta=25°C)

	Symbol	Rating	Unit
Max. Vcc	Vcc	15	V
Max. dissipation	PD	400	mW
Operating temperature	Topt	-20 ~ 75	°C
Storage temperature	Tstg	-65 ~ 150	°C

ELECTRICAL SPECIFICATION (Ta=25°C)

	Symbol	Condition of measurement	Min.	Typ.	Max.	Unit
Current	Icc	Vcc=8.2V	6.0	25	40	mA
FM-IF DETECTOR OUTPUT	Vo (FM)	f=10.7MHz, Input=200μV	4.5	9.0	18	mV
AM-IF DETECTOR OUTPUT	Vo (AM)	f=450KHz, Input=33μV	8.0		16	mV

EQUIVALENT CIRCUIT

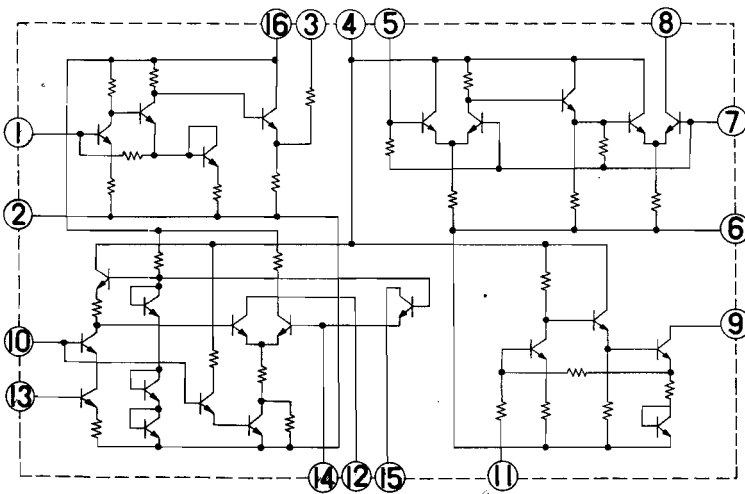

**PIN CONNECTOR
(Top view)**

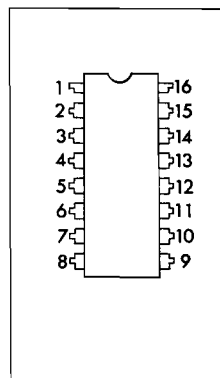

LA3301

ABSOLUTE MAXIMUM RATING. (Ta=25°C)

	Symbol	Rating	Unit
Supply voltage	Vcc	20	V
Lamp driver current max.	IL	40	mA
Operating temperature	Topr	-20 ~ 80	°C
Storage temperature	Tstg	-40 ~ 125	°C

Note:
Condition of measurement =
input signal 100mV rms (Pilot 10%)

ELECTRICAL CHARACTERISTICS (Ta=25°C, Vcc=6V)

	Symbol	Condition of measurement	Min.	Typ.	Max.	Unit
Circuit current	Icc	at zero signal		7.0	10.5	mA
Separation	Sep	at 1kHz	30			dB
Channel balance	ch. B	(Mono)			2.0	dB
Distortion	T.H.D.	(Mono)			1.0	%
Input voltage for ST. IND. ON	Vi		50		100	mV
Output voltage	Vo		71		136	mV
SCA rejection	SCA Rejection			55		dB

EQUIVALENT CIRCUIT

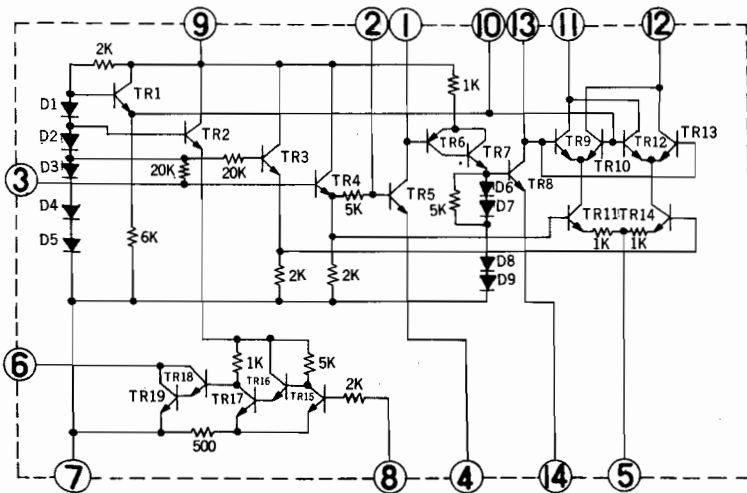

PIN CONNECTOR
(Top view)

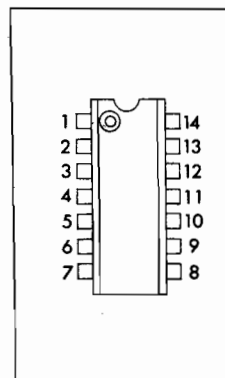

BLOCK DIAGRAM
RF SECTION

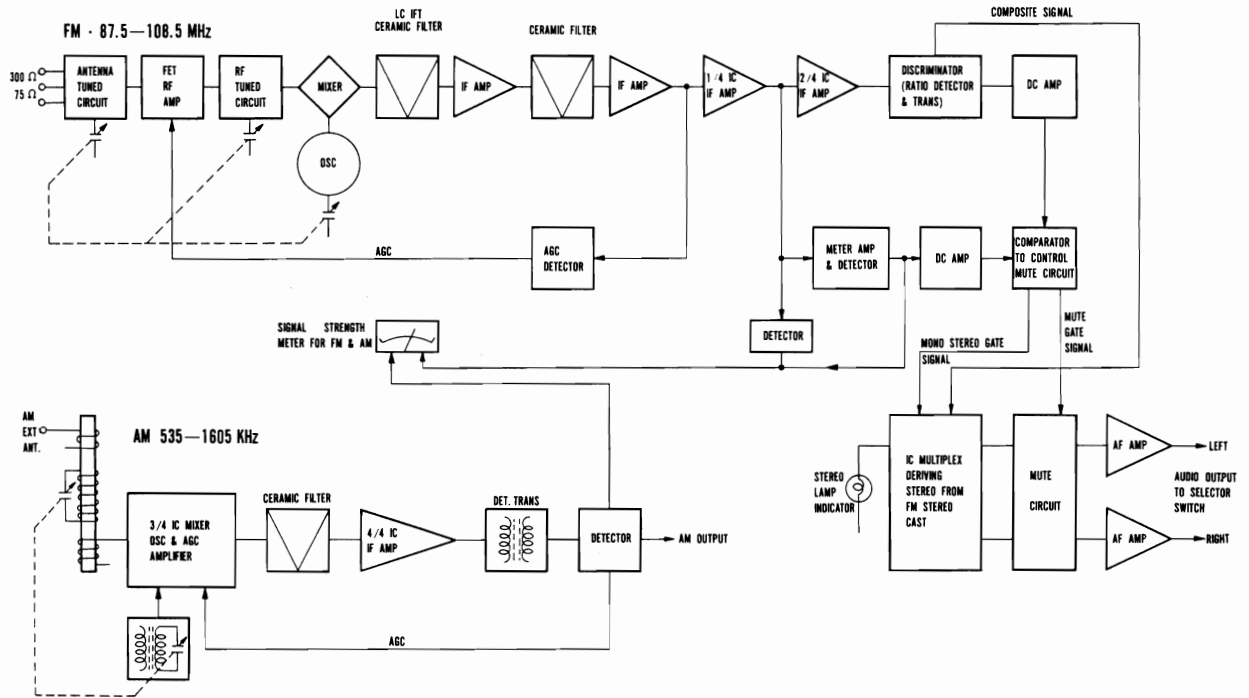

BLOCK DIAGRAM
AUDIO SECTION

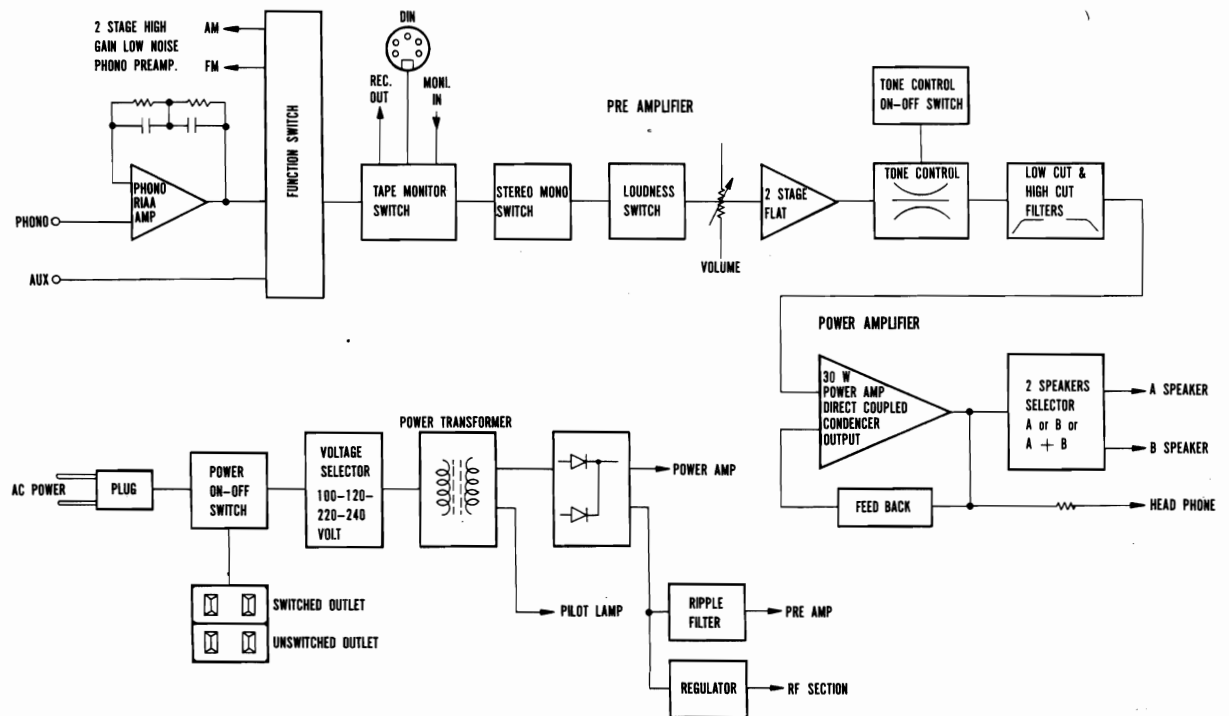

VOLTAGE SELECTOR & OUTLETS ARE FOR \oplus MODEL ONLY.
 FOR BREVITY, ONLY SINGLE CHANNEL IS SHOWN EXCEPT POWER SUPPLY.

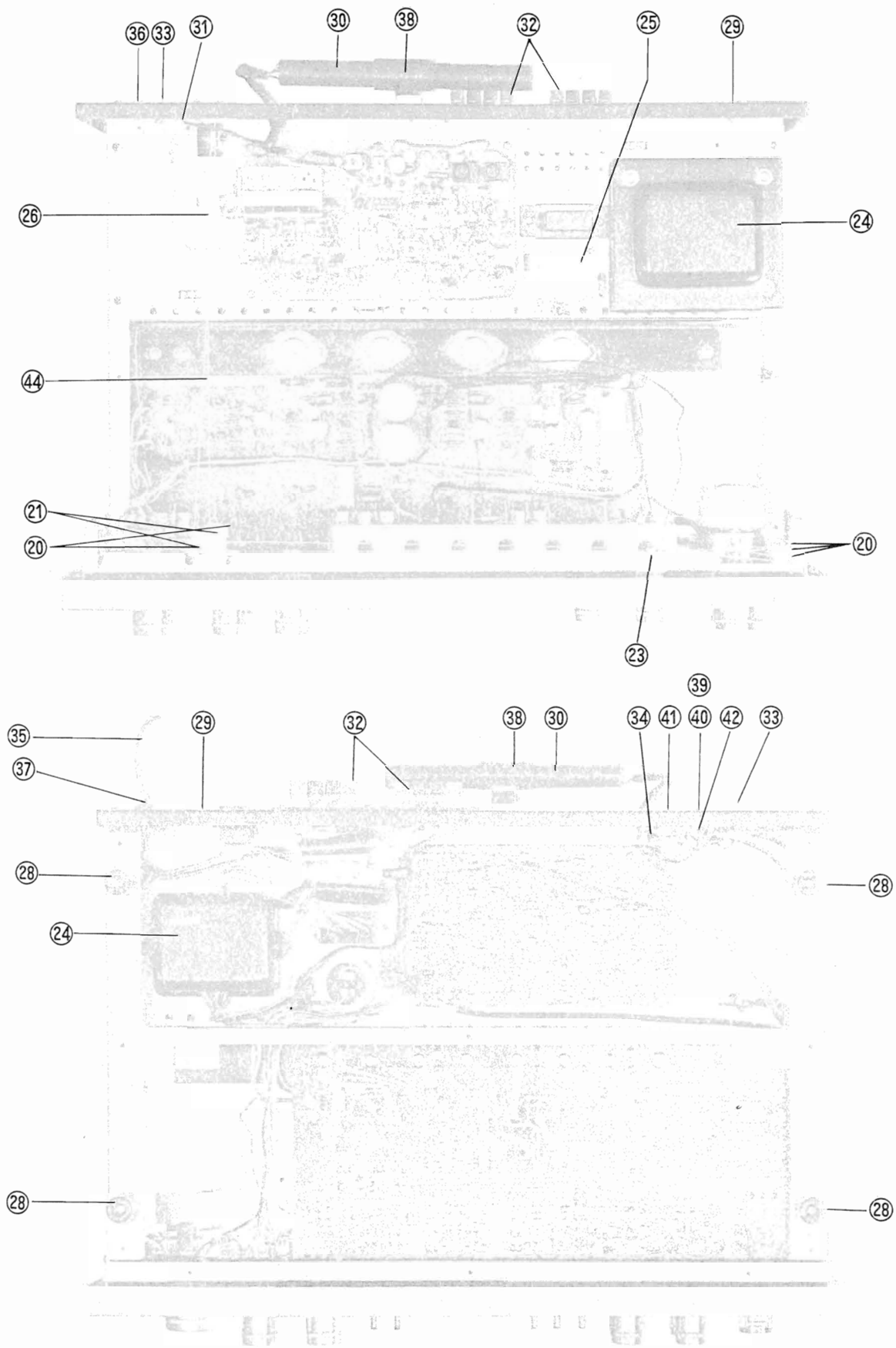

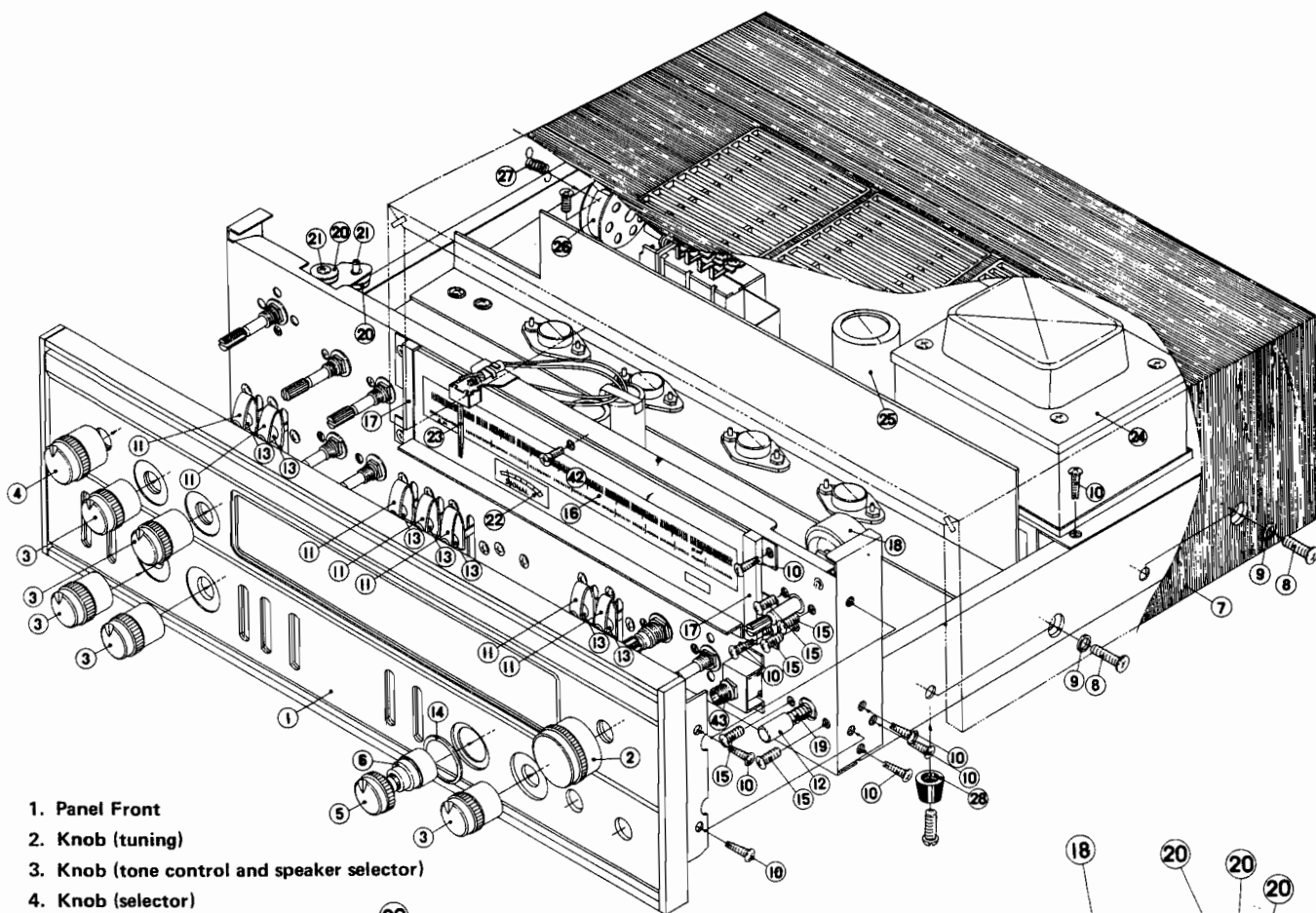

- 1. Panel Front
- 2. Knob (tuning)
- 3. Knob (tone control and speaker selector)
- 4. Knob (selector)
- 5. Knob (outer volume)
- 6. Knob (inner volume)
- 7. Cover
- 8. Screw 5mm x 20mm
- 9. Washer 5mm
- 10. Tapping Screw 3mm x 6mm
- 11. Mask, Paper (switch)
- 12. Knob (power)
- 13. Lever Switch
- 14. Ring
- 15. Screw 3mm x 6mm
- 16. Dial Scale
- 17. Fitting Metal for Dial Scale
- 18. Tuning Shaft and Flywheel Assy.
- 19. Power Switch
- 20. Plastic Pulley
- 21. Pulley Shaft
- 22. Signal Meter
- 23. Tuning Pointer Ass'y
- 24. Power Trans
- 25. Electrolytic Capacitor, 4700 μ 50V
- 26. Drum (tuning capacitor)
- 27. Spring (tension for dial cord)
- 28. Plastic Foot
- 29. Panel Back

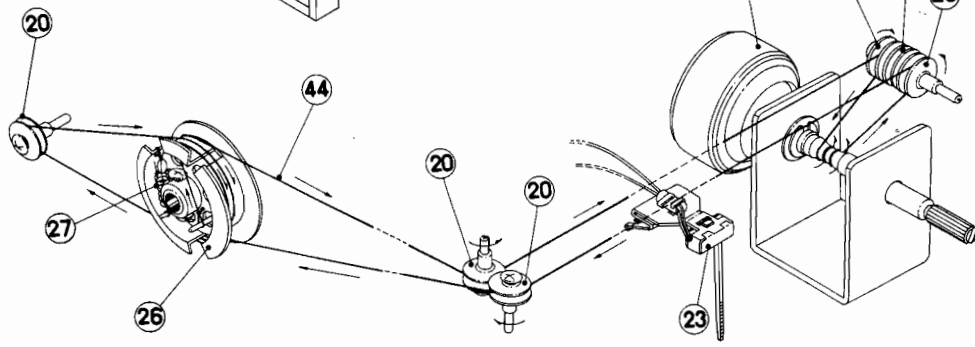

- 30. Bar Antenna
- 31. Antenna Terminal
- 32. Speaker Terminal
- 33. Pin Jack Female
- 34. DIN Type Connector
- 35. AC Cord with Plug
- 36. Earth Terminal
- 37. Cord Bushing
- 38. Bracket, Antenna
- 39. Nut 3mm
- 40. Screw 3mm x 8mm
- 41. Tapping Screw 3mm x 8mm
- 42. Flat Head Screw 3mm x 6mm
- 43. Headphone Jack
- 44. Cord, Dial

0023

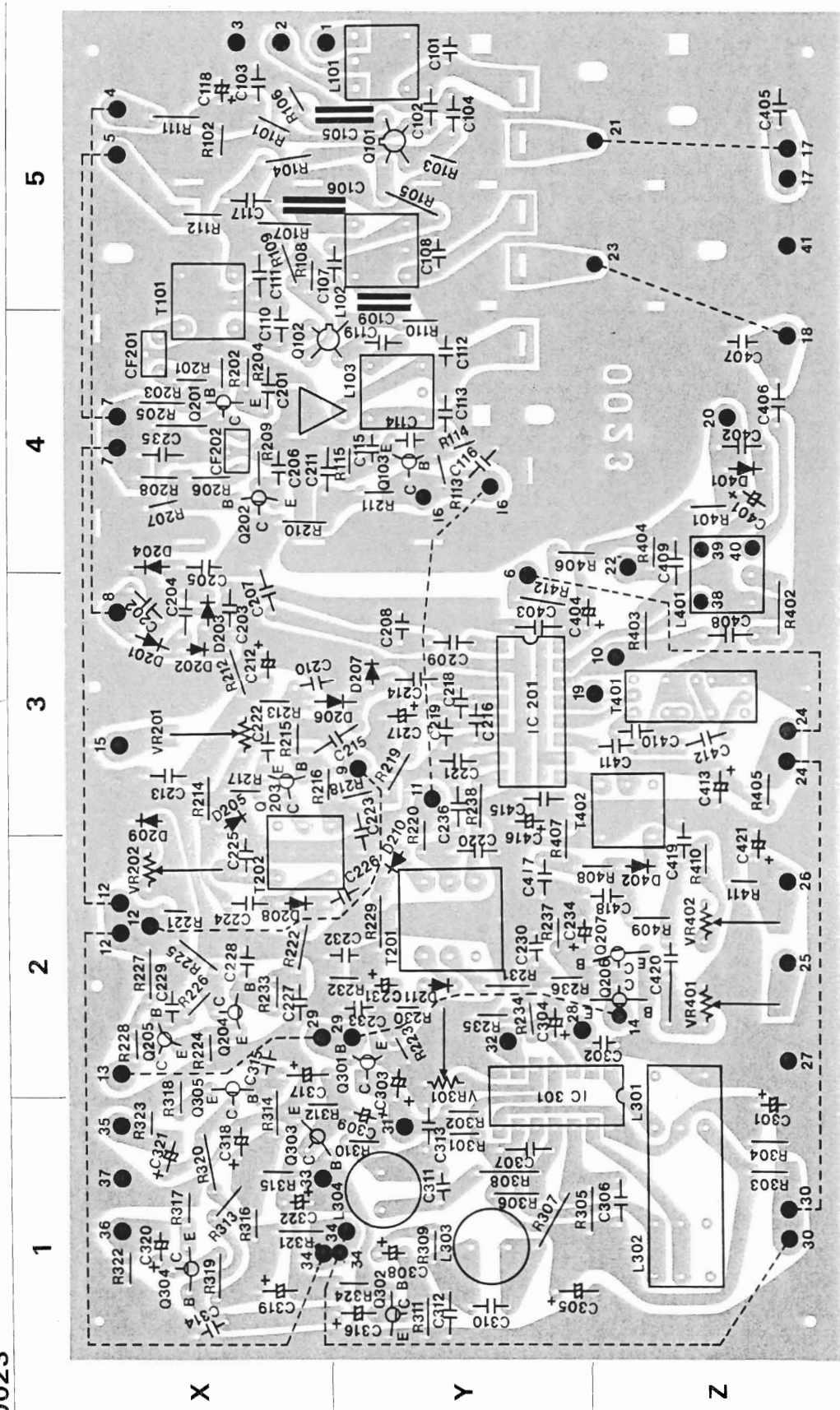

#0023 Component Location

R101	X5	R310	Y1	C217	Y3	VR201	X3	(8)	X3
R102	X5	R311	Y1	C218	Y3	VR202	X2	(9)	Y3
R103	Y5	R312	X1	C219	Y3	VR301	Y2	(10)	Z3
R104	X5	R313	X1	C220	Y2	VR401	Z2	(11)	Y3
R105	Y5	R314	X1	C221	Y3	VR402	Z2	(12)	X2
R106	X5	R315	X1	C222	X3				(13)	X2
R107	X5	R316	X1	C223	Y2, Y3	Q101	Y5	(14)	Z2
R108	X5	R317	X1	C224	X2	Q102	X4, Y4	(15)	X3
R109	X5	R318	X1, X2	C225	X2	Q103	Y4	(16)	Y4
R110	Y4	R319	X1	C226	Y2	Q201	X4	(17)	Z5
R111	X5	R320	X1	C227	X2	Q202	X4	(18)	Z4
R112	X5	R321	X1, Y1	C228	X2	Q203	X3	(19)	Z3
R113	Y4	R322	X1	C229	X2	Q204	X2	(20)	Z4
R114	Y4	R323	X1	C230	Y2	Q205	X2	(21)	Z5
R115	Y4	R324	Y1	C231	Y2	Q206	Z2	(22)	Z4
			R401	Z4	C232	Y2	Q207	Z2	(23)	Z5
R201	X4	R402	Z3	C233	Y2	Q301	Y2	(24)	Z3
R202	X4	R403	Z3	C234	Y2	Q302	Y1	(25)	Z2
R203	X4	R404	Z4	C235	X4	Q303	X1	(26)	Z2
R204	X4	R405	Z3				Q304	X1	(27)	Z2
R205	X4	R406	Y4, Z4	C301	Z1	Q305	X1, X2	(28)	Y2
R206	X4	R407	Y2, Y3	C302	Z2				(29)	X2, Y2
R207	X4	R408	Z2	C303	Y2	IC201	Y3	(30)	Z1
R208	X4	R409	Z2	C304	Y2	IC301	Y1, Y2	(31)	Y1
R209	X4	R410	Z2	C305	Y1, Z1				(32)	Y2
R210	X4	R411	Z2	C306	Z1	D201	X3	(33)	X1
R211	Y4	R412	Y3	C307	Y1	D202	X3	(34)	X1, Y1
R212	X3				C308	Y1	D203	X3	(35)	X1
R213	X3	C101	Y5	C309	Y1	D204	X4	(36)	X1
R214	X3	C102	Y5	C310	Y1	D205	X3	(37)	X1
R215	X3	C103	X5	C311	Y1	D206	Y3	(38)	Z3
R216	Y3	C104	Y5	C312	Y1	D207	Y3	(39)	Z4
R217	X3	C105	Y5	C313	Y1	D208	X2	(40)	Z4
R218	Y3	C106	X5, Y5	C314	X1	D209	X3	(41)	Z5
R219	Y3	C107	Y5	C315	X2	D210	Y2			
R220	Y2, Y3	C108	Y5	C316	Y1	D211	Y2			
R221	X2	C109	Y5	C317	X2, Y2	D401	Z4			
R222	X2	C110	X4, X5	C318	X1	D402	Z2			
R223	Y2	C111	X5	C319	X1						
R224	X2	C112	Y4	C320	X1	CF201	X4			
R225	X2	C113	Y4	C321	X1	CF202	X4			
R226	X2	C114	Y4	C322	X1						
R227	X2	C115	Y4				T101	X4, X5			
R228	X2	C116	Y4	C401	Z4	T201	Y2			
R229	Y2	C117	X5	C402	Z4	T202	X2			
R230	Y2	C119	Y4	C403	Y3	T401	Z3			
R231	Y2				C404	Z3	T402	Z3			
R232	Y2				C405	Z5						
R233	X2	C201	X4	C406	Z4	L101	Y5			
R234	Y2	C202	X3	C407	Z4	L102	Y5			
R235	Y2	C203	X3	C408	Z3	L103	Y4			
R236	Y2	C204	X3	C409	Z3, Z4	L301	Z1, Z2			
R237	Y2	C205	X4	C410	Z3	L302	Z1			
R238	Y3	C206	X4	C411	Z3	L303	Y1			
			C207	X3, X4	C412	Z3	L304	Y1			
R301	Y1	C208	Y3	C413	Z3	L401	Z3, Z4			
R302	Y1	C209	Y3	C415	Y3						
R303	Z1	C210	X3, Y3	C416	Y3	(1)	X5, Y5			
R304	Z1	C211	Y4	C417	Y2	(2)	X5			
R305	Z1	C212	X3	C418	Z2	(3)	X5			
R306	Y1	C213	X3	C419	Z2, Z3	(4)	X5			
R307	Y1	C214	Y3	C420	Z2	(5)	X5			
R308	Y1	C215	Y3	C421	Z2, Z3	(6)	Y3, Y4			
R309	Y1	C216	Y3				(7)	X4			

#0018 Component Location

R325 Y5, Z5	R615b X4	R913b Z2	SW703 Z3
R501a X1	R616a	... X2, X3	R914a Y1	C901a Y5
R501b Y1	R616b	... X3, X4	R914b Y2	C901b Y5
R502a X1	R617a	... X2, X3	R915a Y3	C902a Z3
R502b Y1	R617b	.. X3, X4	R915b Z3	C902b Z4
R503a X1	R618a X2	R916 Y4	C903a Z2
R503b Y1	R618b X4			C903b Z2
R504a X1	R619a	... X2, X3	C501a X1	C904a	... Z1, Z2
R504b Y1	R619b	... X3, X4	C501b Y1	C904b Z2
R505a X1	R620a	... X2, X3	C502a X1	C905a	... Y1, Y2
R505b Y1	R620b	... X3, X4	C502b Y1	C905b Y2
R506a X1	R621a X3	C503a X1	C906a Z2
R506b Y1	R621b X3	C503b Y1	C906b Z2
R507a X1	R622a	... X3, Y3	C504a X1	C907a Z2
R507b Y1	R622b	... X3, Y3	C504b Y1	C907b Z2
R508a X1	R623a	... Y2, Y3	C505a X1	C908a	... Z1, Z2
R508b Y1	R623b	... Y3, Y4	C505b Y1	C908b Z2
R509a X1	R624 X4	C506a X1	C909a Z1
R509b Y1	R625 Y4, Y5	C506b Y1	C909b Z2
R510a X1	R626 Y4, Y5	C507a X2	C910a Y1
R510b Y1	R627	... X4, X5	C507b Y2	C910b Y2
R511a X1	R628	... X4, X5	C508a X1	C911 Z4
R511b Y1	R629 X4	C508b Y1		
R512a X1	R630 Y5	C509a X2	VR601a X2
R512b Y1	R631 Y5	C509b Y2	VR601b X4
R513a X1	R632 Y4	C510a X2	VR901 Z5
R513b Y1	R701a Z1	C510b Y2	VR902	... Z1, Z2
R514a X1	R701b	... Y1, Z1	C511	... X2, Y2	VR903 Z2
R514b Y1	R702a Z4	C601a Y3		
R515a X2	R702b Z4	C601b Y3	Q501a X1
R515b Y2	R703a Z3	C602a Y2	Q501b Y1
R516a X2	R703b Z3	C602b Y4	Q502a X1
R516b Y2	R704a Y3	C603a Y2	Q502b Y1
R517 Y2	R704b Y3	C603b Y4	Q601a Y2
		R705a Y3	C604a X2	Q601b Y4
R601a Y3	R705b Y3	C604b X4	Q602a X2
R601b Y3			C605a Y2	Q602b X4
R602a Y2	R801	... X5, Y5	C605b Y4	Q603a	... Y2, Y3
R602b Y4	R802	... X5, Y5	C606a	... X2, Y2	Q603b	... Y3, Y4
R603a Y3	R901a	... Y5, Z5	C606b	... X4, Y4	Q604a X2
R603b Y3	R901b	... Y5, Z5	C607a	... X2, Y2	Q604b X4
R604a	... Y2, Y3	R902a	... Y3, Y4	C607b	... X4, Y4	Q605a	... X2, X3
R604b	... Y3, Y4	R902b Y4	C608a X2	Q605b	... X3, X4
R605a Y2	R903a Z3	C608b X4	Q608 Y4
R605b Y4	R903b Z4	C609a X3	Q609 X4
R606a	... Y2, Y3	R904a	... Y3, Z3	C609b Y3	Q610 X4
R606b	... Y3, Y4	R904b	... Y4, Z4	C610 X4	Q901a Z3
R607a	... Y2, Y3	R905a	... Y3, Y4	C611 Y4	Q901b Z4
R607b	... Y3, Y4	R905b Y4	C612 X4	Q902a Y3
R608a Y2	R906a Z3	C613 Y4	Q902b Y4
R608b Y4	R906b Z4	C614	... X4, Y4	Q903a Z1
R609a X2	R907a Z4			Q903b Z2
R609b X4	R907b Z4	C701a Y4		
R610a	... Y2, Y3	R908a	... Y2, Z2	C701b Y4	D601a X3
R610b	... Y3, Y4	R908b	... Y2, Z2	C702a Z4	D601b X3
R611a X2	R909a Z2	C702b Z4	D602a X3
R611b X4	R909b Z2	C703a Y3	D602b X3
R612a	... X2, X4	R910a Z1	C703b Y3	D801 X5
R612b	... X3, X4	R910b Z2	C704a Z3	D802 X5
R613a Y2	R911a	... Y1, Z1	C704b Z3	D803	... Y4, Y5
R613b Y4	R911b	... Y2, Z2			D804	... Y4, Y5
R614a X2	R912a Z1	C801 X5		
R614b X4	R912b Z2	C802 X5	SW701 Z1
R615a X2	R913a Z1	C803 Y4	SW702 Z1

REPLACEMENT PARTS

RESISTORS; $\pm 10\%$ $\frac{1}{4}$ watt deposited carbon, unless noted otherwise.

SYMBOL NO.	DESCRIPTION	SYMBOL NO.	DESCRIPTION	SYMBOL NO.	DESCRIPTION	SYMBOL NO.	DESCRIPTION
R101	100K	R230	470	R408	150K	R620a, b	1W 10
R102	1M	R231	47	R409	470	R621a, b	1K
R103	100K	R232	10K	R410	3.3K	R622a, b	1W 220
R104	150K	R233	5.6K	R411	3.3K	R623a, b	1.2K
R105	100	R234	22K	R412	1K	R624	33
R106	100	R235		R451	82K	R625	47
R107	330	R236	10K			R626	47
R108	10K	R237	33K	R501a, b	68K	R627	27K
R109	220K	R238	120	R502a, b	22K	R628	33
R110	100	R251	220	R503a, b	3.9K	R629	47
R111	JUMPER	R252	100K	R504a, b	680K	R630	33K
R112	100			R505a, b	1M	R631	180K
R113	18K	R301	10K	R506a, b	180	R632	560
R114	10K	R302	1.2K	R507a, b	120K		
R115	1.8K	R303	680	R508a, b	47K	R651	1W 470
		R304	4.7K	R509a, b	470		
R201		R305	5.6K	R510a, b	27K	R701a, b	5.6K
R202	2.2K	R306	5.6K	R511a, b	820	R702a, b	27K
R203	6.8K	R307	2.2K	R512a, b	1.5K	R703a, b	820K
R204	1K	R308	2.2K	R513a, b	10K	R704a, b	33K
R205	1K	R309	10K	R514a, b	150K	R705a, b	10K
R206	220	R310	10K	R515a, b	39K		
R207	2.7K	R311	100K	R516a, b	820K	R801	10W 560
R208	15K	R312	100K	R517	4.7K	R802	7W 1K
R209	1K	R313	180K	R551a, b	1.8K	R851	56
R210	1.2K	R314	180K				
R211	470	R315	15K	R601a, b	3.3K	R901a, b	3.3K
R212	15K	R316	33K	R602a, b	47K	R902a, b	100K
R213	2.7K	R317	560	R603a, b	39K	R903a, b	10K
R214	1.5K	R318	560	R604a, b	150K	R904a, b	470K
R215	820	R319	2.2K	R605a, b	2.2K	R905a, b	10K
R216	10K	R320	2.2K	R606a, b	8.2K	R906a, b	1.2K
R217	1K	R321	1K	R607a, b	1.5K	R907a, b	5.6K
R218	470	R322	33K	R608a, b	3.3K	R908a, b	6.8K
R219	330	R323	33K	R609a, b	3.3K	R909a, b	18K
R220	270	R324	100K	R610a, b	47	R910a, b	10K
R221	33K	R325	10K	R611a, b	5.6K	R911a, b	6.8K
R222	5.6K			R612a, b	100	R912a, b	18K
R223	10K	R401	1.2K	R613a, b	10	R913a, b	820K
R224	33	R402	56	R614a, b	100	R914a, b	6.8K
R225	330K	R403	1.5K	R615a, b	10	R915a, b	220K
R226	10K	R404	680	R616a, b	100	R916	2.2K
R227	4.7K	R405	1.5K	R617a, b	270		
R228	1M	R406	560K	R618a, b	2W 0.3		
R229	470	R407	68K	R619a, b	2W 0.3		

CAPACITORS

SYMBOL NO.	DESCRIPTION	SYMBOL NO.	DESCRIPTION
C101	18PF $\pm 5\%$ 50V ceramic	C117	0.04 μ F + 80% - 20% 25V ceramic
C102	0.01 μ F + 80% - 20% 25V ceramic	C118	NONE
C103	0.04 μ F + 80% - 20% 25V ceramic	C119	JUMPER
C104	0.01 μ F + 80% - 20% 25V ceramic	C151	0.04 μ F + 80% - 20% 25V ceramic
C105	4700PF + 100% - 0% 50V ceramic		
C106	4700PF + 100% - 0% 50V ceramic	C201	0.01 μ F + 80% - 20% 25V ceramic
C107	0.01 μ F + 80% - 20% 25V ceramic	C202	0.04 μ F + 80% - 20% 25V ceramic
C108	20PF $\pm 5\%$ 50V ceramic	C203	0.01 μ F + 80% - 20% 25V ceramic
C109	4700PF + 100% - 0% 50V ceramic	C204	0.01 μ F + 80% - 20% 25V ceramic
C110	33PF $\pm 5\%$ 50V ceramic	C205	0.01 μ F + 80% - 20% 25V ceramic
C111	0.04 μ F + 80% - 20% 25V ceramic	C206	0.01 μ F + 80% - 20% 25V ceramic
C112	20PF $\pm 5\%$ 50V ceramic	C207	33PF $\pm 5\%$ 50V ceramic
C113	10PF $\pm 5\%$ 50V ceramic	C208	10PF $\pm 5\%$ 50V ceramic
C114	33PF $\pm 5\%$ 50V ceramic	C209	0.01 μ F + 80% - 20% 25V ceramic
C115	10PF $\pm 5\%$ 50V ceramic	C210	0.01 μ F + 80% - 20% 25V ceramic
C116	0.04 μ F + 80% - 20% 25V ceramic		

SYMBOL NO.	DESCRIPTION	SYMBOL NO.	DESCRIPTION
C211	0.04 μ F + 80% - 20% 25V ceramic	C411	0.01 μ F + 80% - 20% 25V ceramic
C212	10 μ F + 50% - 10% 16V electrolytic	C412	0.01 μ F + 80% - 20% 25V ceramic
C213	0.04 μ F + 80% - 20% 25V ceramic	C413	100 μ F + 50% - 10% 16V electrolytic
C214	0.01 μ F + 80% - 20% 25V ceramic	C414	NONE
C215	33PF \pm 5% 50V ceramic	C415	0.04 μ F + 80% - 20% 25V ceramic
C216	0.04 μ F + 80% - 20% 25V ceramic	C416	0.47 μ F + 75% - 10% 50V electrolytic
C217	100 μ F + 50% - 10% 16V electrolytic	C417	0.04 μ F + 80% - 20% 25V ceramic
C218	100PF \pm 10% 50V ceramic	C418	6800PF \pm 10% 50V ceramic
C219	100PF \pm 10% 50V ceramic	C419	4700PF \pm 10% 50V ceramic
C220	0.04 μ F + 80% - 20% 25V ceramic	C420	0.056 μ F \pm 10% 50V mylar
C221	0.04 μ F + 80% - 20% 25V ceramic	C421	100 μ F + 50% - 10% 6V electrolytic
C222	0.01 μ F + 80% - 20% 25V ceramic		
C223	0.04 μ F + 80% - 20% 25V ceramic	C501a, b	2.2 μ F \pm 20% 350 tantalum
C224	0.01 μ F + 80% - 20% 25V ceramic	C502a, b	100 μ F + 50% - 10% 10V electrolytic
C225	0.04 μ F + 80% - 20% 25V ceramic	C503a, b	47PF \pm 10% 50V ceramic
C226	0.01 μ F + 80% - 20% 25V ceramic	C504a, b	150PF \pm 10% 50V ceramic
C227	0.01 μ F + 80% - 20% 25V ceramic	C505a, b	120PF \pm 10% 50V ceramic
C228	0.01 μ F + 80% - 20% 25V ceramic	C506a, b	10 μ F + 50% - 10% 16V electrolytic
C229	0.01 μ F + 80% - 20% 25V ceramic	C507a, b	22 μ F + 50% - 10% 6V electrolytic
C230	220PF \pm 10% 50V ceramic	C508a, b	0.47 μ F + 40% - 20% 35V tantalum
C231	4.7 μ F + 75% - 10% 25V electrolytic	C509a, b	1800PF \pm 10% 50V mylar
C232	220PF \pm 10% 50V ceramic	C510a, b	6800PF \pm 10% 50V mylar
C233	220PF \pm 10% 50V ceramic	C511	100 μ F + 50% - 10% 50V electrolytic
C234	2.2 μ F + 75% - 10% 25V electrolytic		
C235	0.04 μ F + 80% - 20% 25V ceramic	C601a, b	2.2 μ F \pm 20% 35V tantalum
C251	0.04 μ F + 80% - 20% 25V ceramic	C602a, b	47 μ F + 50% - 10% 35V electrolytic
		C603a, b	120PF \pm 10% 50V ceramic
C301	4.7 μ F + 75% - 10% 25V electrolytic	C604a, b	47 μ F + 50% - 10% 35V electrolytic
C302	1500PF \pm 10% 50V ceramic	C605a, b	220 μ F + 50% - 10% 35V electrolytic
C303	10 μ F + 50% - 10% 16V electrolytic	C606a, b	33PF \pm 10% 50V ceramic
C304	4.7 μ F + 75% - 10% 50V electrolytic	C607a, b	180PF \pm 10% 50V ceramic
C305	330 μ F + 50% - 10% 16V electrolytic	C608a, b	0.047 μ F \pm 10% 50V mylar
C306	4700PF \pm 10% 50V ceramic	C609a, b	2200 μ F + 50% - 10% 50V electrolytic
C307	4700PF \pm 10% 50V ceramic	C610	33 μ F + 50% - 10% 63V electrolytic
C308	0.47 μ F + 75% - 10% 50V electrolytic	C611	100 μ F + 50% - 10% 50V electrolytic
C309	0.47 μ F + 75% - 10% 50V electrolytic	C612	0.005 μ F + 80% - 20% 25V ceramic
C310	1200PF \pm 10% 50V ceramic	C613	100 μ F + 50% - 10% 50V electrolytic
C311	1200PF \pm 10% 50V ceramic	C614	33 μ F + 50% - 10% 63V electrolytic
C312	3900PF \pm 10% 50V ceramic	C651a, b	220PF \pm 10% 50V ceramic
C313	3900PF \pm 10% 50V ceramic		
C314	1500PF \pm 10% 50V ceramic	C701a, b	220PF \pm 10% 50V ceramic
C315	1500PF \pm 10% 50V ceramic	C702a, b	0.01 μ F \pm 10% 50V mylar
C316	0.47 μ F + 75% - 10% 50V electrolytic	C703a, b	0.1 μ F \pm 10% 50V mylar
C317	0.47 μ F + 75% - 10% 50V electrolytic	C704a, b	2200PF \pm 10% 50V mylar
C318	47 μ F + 50% - 10% 6V electrolytic		
C319	470 μ F + 50% - 10% 16V electrolytic	C801	0.01 μ F + 100% - 0% 500V ceramic
C320	0.47 μ F + 75% - 10% 50V electrolytic	C802	0.01 μ F + 100% - 0% 500V ceramic
C321	0.47 μ F + 75% - 10% 50V electrolytic	C803	220 μ F + 50% - 10% 16V electrolytic
C322	0.47 μ F + 75% - 10% 50V electrolytic	C851	0.047 μ F \pm 20% AC250V
C351	1200PF \pm 10% 50V ceramic	C852	0.047 μ F \pm 20% AC250V
C352	1200PF \pm 10% 50V ceramic	C853	4700 μ F \pm 50% - 10% 80V electrolytic
C401	10 μ F + 50% - 10% 16V electrolytic	C901a, b	1 μ F \pm 20% 25V tantalum
C402	0.04 μ F + 80% - 20% 25V ceramic	C902a, b	18PF \pm 10% 50V ceramic
C403	0.04 μ F + 80% - 20% 25V ceramic	C903a, b	10 μ F \pm 20% 35V tantalum
C404	10 μ F + 50% - 10% 16V electrolytic	C904a, b	100PF \pm 10% 50V ceramic
C405	10PF \pm 5% 50V ceramic	C905a, b	1200PF \pm 10% 50V mylar
C406	360PF \pm 5% 50V ceramic	C906a, b	0.033 μ F \pm 10% 50V mylar
C407	20PF \pm 5% 50V ceramic	C907a, b	0.033 μ F \pm 10% 50V mylar
C408	4700PF \pm 10% 50V ceramic	C908a, b	3.3 μ F \pm 20% 25V tantalum
C409	0.04 μ F + 80% - 20% 25V ceramic	C909a, b	33PF \pm 10% 50V ceramic
C410	0.04 μ F + 80% - 20% 25V ceramic	C910a, b	2.2 μ F \pm 20% 35V tantalum
		C911	220 μ F + 50% - 10% 35V electrolytic

TRANSISTORS & IC

SYMBOL NO.	DESCRIPTION	SYMBOL NO.	DESCRIPTION
Q101	FM RF AMPLIFIER	3SK45	
Q102	FM MIXER	3SK45	
Q103	FM LOCAL OSCILATOR	2SC710	
Q201	FM IF AMPLIFIER	2SC710	
Q202	FM IF AMPLIFIER	2SC710	
Q203	FM SIGNAL METER AMPLIFIER	2SC710	
Q204	FM MUTING DC AMPLIFIER	2SC945, 2SC711	
Q205	FM MUTING DC AMPLIFIER	2SC945, 2SC711	
Q206	FM MUTING SWITCH	2SC945, 2SC711	
Q207	FM MUTING SWITCH	2SC945, 2SC711	
Q301	FM MUTING SWITCH	2SC945, 2SC711	
Q302	FM MUTING	2SC945, 2SC711	
Q303	FM MUTING	2SC945, 2SC711	
Q304	FM AUDIO AMPLIFIER	2SC945, 2SC711	
Q305	FM AUDIO AMPLIFIER	2SC945, 2SC711	
Q501a, b	PHONO AMPLIFIER	2SC1000	
Q502a, b	PHONO AMPLIFIER	2SA640	
Q601a, b	POWER AMPLIFIER	2SA763	
Q602a, b	POWER AMPLIFIER	2SC1539	
Q603a, b	POWER AMPLIFIER	2SC1509	
Q604a, b	POWER AMPLIFIER	2SC1509	
Q605a, b	POWER AMPLIFIER	2SA777	
Q606a, b	POWER AMPLIFIER	2SC1030	
Q607a, b	POWER AMPLIFIER	2SC1030	
Q608	POWER SUPPLY	2SC1509	
Q609	POWER SUPPLY	2SC1509	
Q610	POWER SUPPLY	2SC1509	
Q901a, b	TONE AMPLIFIER	2SC1000	
Q902a, b	TONE AMPLIFIER	2SA763	
Q903a, b	TONE AMPLIFIER	2SC1000	
IC201	FM/AM IF AMPLIFIER	AN277	
IC301	FM STEREO DEMODULATOR	LA3301	

DIODES

D201	AGC DETECTOR	IN60P	D401	BIAS STABILIZER	KB169
D202	AGC DETECTOR	IN60P	D402	AUDIO & METER DETECTOR	IN60P
D203	AGC & METER DETECTOR	IN60P			
D204	AGC & METER DETECTOR	IN60P	D601a, b	DETECTOR FOR PROTECTION	IS2473
D205	METER DETECTOR	IN60P	D602a, b	DETECTOR FOR PROTECTION	IS188
D206	METER DETECTOR	IN60P			
D207	METER DETECTOR	IN60P	D801	RECTIFIER	VO3
D208	MUTING DC AMP. DETECTOR	IN60P	D802	RECTIFIER	VO3
D209	VOLTAGE STABILIZER	KB269	D803	VOLTAGE STABILIZER	BZ-120
D210	RATIO DETECTOR	IN60P	D804	VOLTAGE STABILIZER	BZ-140
D211	RATIO DETECTOR	IN60P			

VARIABLE RESISTORS

VR201 5K-B	SEMI FIXED FOR FM METER SETTING	VR901 200K-BX2 with C.T.	FOR VOLUME CONT.
VR202 1K-B	SEMI FIXED FOR FM MUTING LEVEL	VR902 100K-B	FOR TONE CONT.
VR301 1K-B	SEMI FIXED FOR FM SEPARATION	VR903 100K-B	FOR TONE CONT.
VR401 20K-B	SEMI FIXED FOR AM OUTPUT LEVEL	VR904 100K-B	FOR TONE CONT.
VR402 5K-B	SEMI FIXED FOR AM METER SETTING	VR905 100K-B	FOR TONE CONT.
VR601a,b 1K-B	SEMI FIXED FOR POWER AMP.		

SWITCHES

S1 3-6-4	ROTARY SW FUNCTION	S703 2-2	LEVER SW LOW CUT
S2 1-2-4	ROTARY SW SPEAKER	S704 2-2	LEVER SW HIGH CUT
S3 2-2	PUSH SW POWER	S705 2-2	LEVER SW LOUDNESS
		S706 1-2	LEVER SW MUTING
S701 2-2	LEVER SW MONITOR	S707 4-2	LEVER SW TONE
S702 1-2	LEVER SW MODE		

TRANSFORMERS, COILS & FILTERS

SYMBOL NO.	DESCRIPTION	SYMBOL NO.	DESCRIPTION
T101	FM IF TRANS	109A	
T201	FM DISCRIMINATOR TRANS	215D	
T202	FM METER & MUTING TRANS	204E	
T401	AM IF TRANS	406A	
T402	AM IF TRANS	401D	
L101	FM ANT COIL	107A	
L102	FM RF COIL	121B	
L103	FM OSCILATOR COIL	115L	
L301	19KHz COIL	312A	
L302	38KHz COIL	310B	
L303	FM LOW-PASS FILTER COIL	146LYD-393J	
L304	FM LOW-PASS FILTER COIL	146LYD-393J	
L401	AM OSCILATOR COIL	413L	
CF201	FM IF FILTER	SFE 10.7MA-8	
CF202	FM IF FILTER	SFE 10.7MA-8	

SPECIFICATIONS

AUDIO SECTION

CIRCUIT: Quasi-complementary direct coupled condenser output amplifier

RMS POWER: 30/30 Watts (8 ohms, both channels driven)

T.H.D.: < 0.05% (8 ohms, 30 Watts at 1KHz)
0.1% (20-20KHz)

FREQUENCY RESPONSE: 10Hz-25KHz (-1dB)
5Hz-45KHz (-3dB)

POWER BANDWIDTH: 10Hz-40KHz (0.3%, -3dB)

INPUT SENSITIVITY: PHONO 2.5mV
(at 30 Watts, 8 ohms, 1KHz)
AUX 150mV
TAPE MONITOR 150mV

REC OUT: TAPE MONITOR 150mV

DIN CONNECTOR: TAPE MONITOR 150mV
REC. OUT 30mV 90K Ω
R.I.A.A.

EQUALIZER CURVE: PERMISSIBLE PHONO INPUT VOLTAGE: 100mV max at 1KHz

TONE CONTROL: Treble ± 8 dB (10KHz)
Bass ± 8 dB (100Hz)

FILTER: HIGH CUT 7KHz 6dB/oct
LOW CUT 70Hz 6dB/oct

LOUDNESS CONTROL: Available

S/N RATIO: PHONO >65dB
AUX >80dB
TAPE MONITOR >80dB

RESIDUAL NOISE: < 1.0mV

ACCESSORIES: Head-phone Jack, Mode Selector (stereo-mono),
Speaker Selector (A, B, A+B, OFF),
Tape Monitor Circuit,
Tone Control ON-OFF Switch,
De-emphasis Switch (50/75 μ sec) for R600E.
AC Outlet for R600E,
Voltage Selector (100, 120, 220, 240V) for R600E

AM SECTION

IHF SENSITIVITY: 250 μ V/m

S/N RATIO: 50dB

IF REJECTION: 40dB

IMAGE REJECTION: 50dB

T.H.D.: 0.7%

FM SECTION

IHF SENSITIVITY: 2.1 μ V

SENSITIVITY FOR 50dB S/N: 3.8 μ V

ULTIMATE S/N: 70dB

T.H.D. Mono: 0.3%

Stereo: 0.6%

ALTERNATE CHANNEL SELECTIVITY: 55dB

IF REJECTION: 90dB

IMAGE REJECTION: 60dB

SPURIOUS RESPONSE REJECTION: 70dB

AM SUPPRESSION: 50dB

CAPTURE RATIO: 1.7dB

STEREO SEPARATION: 38dB (at 400Hz)
30dB (100Hz-10KHz)

MUTING THRESHOLD: 7 μ V

STEREO THRESHOLD: 7 μ V

FREQUENCY RESPONSE (Mono Stereo): 30Hz to 15KHz +0.3dB
-2.5dB

GENERAL SPECIFICATION

POWER REQUIREMENT: R600S 220V 50-60Hz AC
R600E 100/120/220/240V
50-60Hz AC

POWER CONSUMPTION: 140W (at rated output)

DIMENSIONS: (W) 480mm (18-1/8") x
(D) 360mm (14-3/16") x
(H) 345mm (13-5/8")

WEIGHT: 13Kgs

AUDIO SECTION

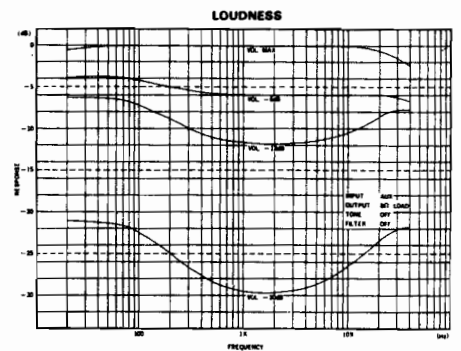
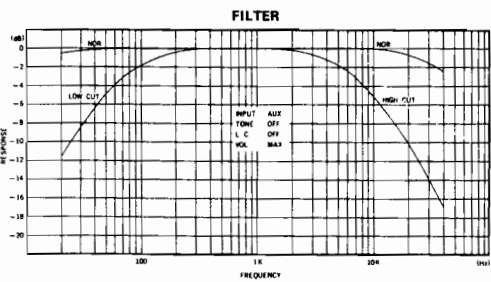
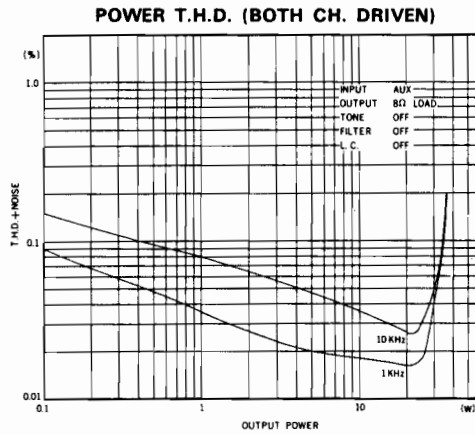
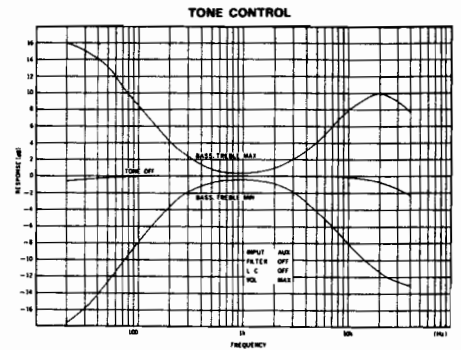
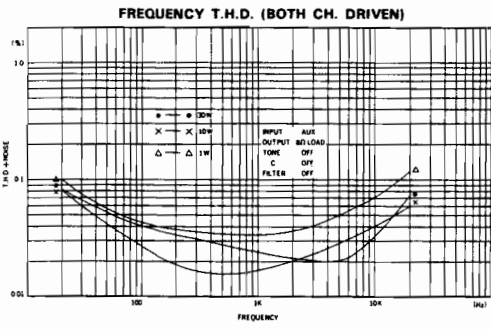

RF SECTION

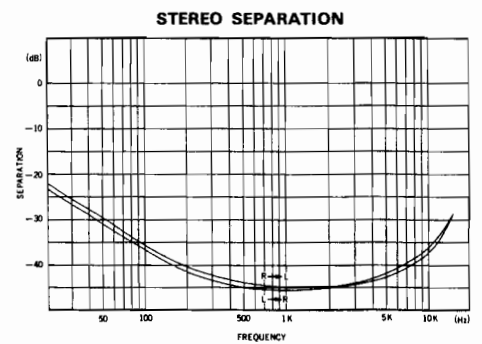
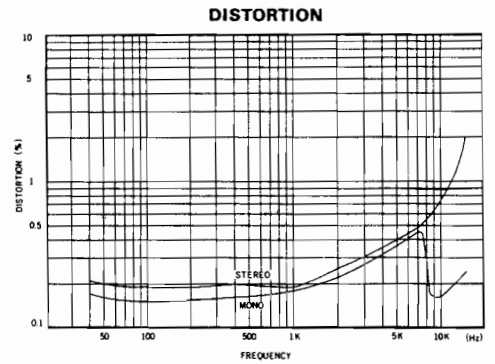
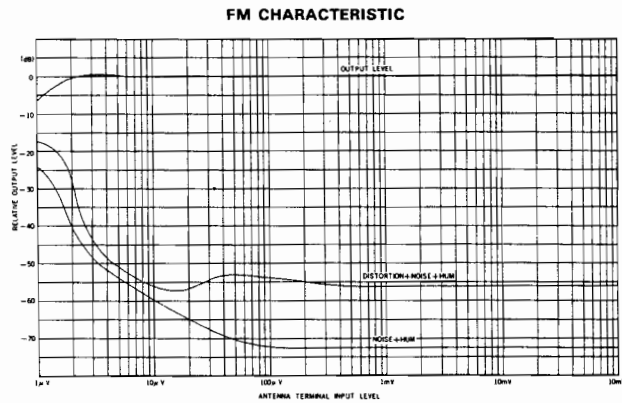
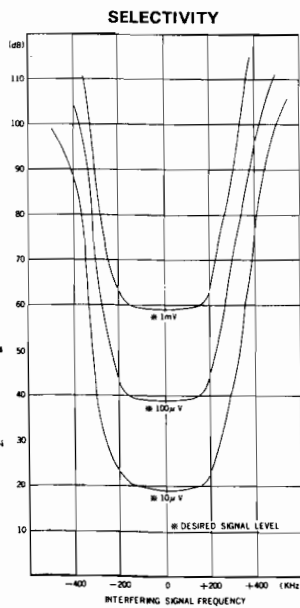

RF SECTION

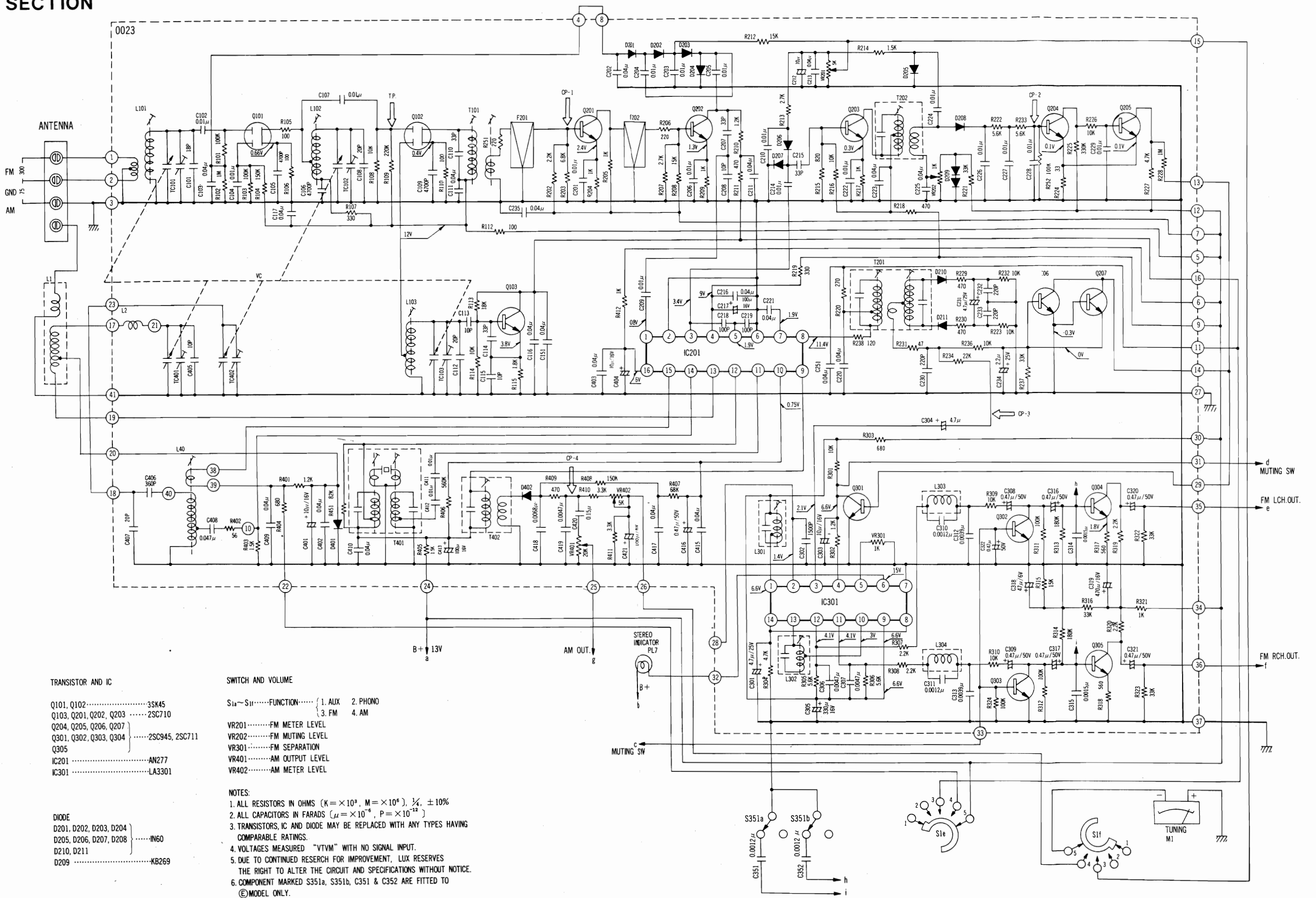

AUDIO SECTION

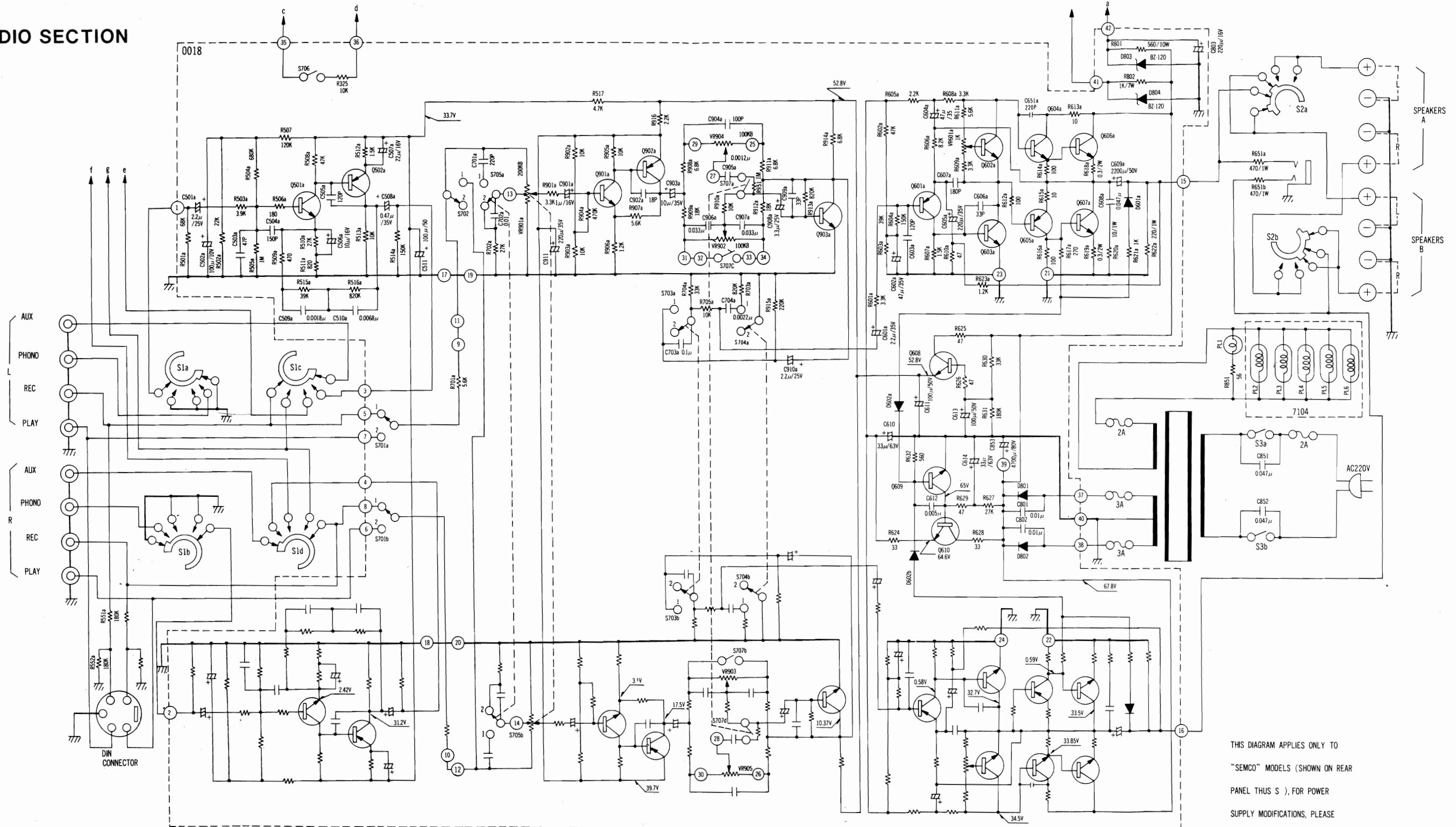

TRANSISTOR AND DIODE

Q502a,b	2SA640	D801, D802	V03
Q901a,b Q903a,b	2SC1000	D602a,b	IS188
Q902a,b Q601a,b	2SA763	D601a,b	IS2473
Q602a,b	2SC1539	D803, D804	BZ-120
Q605a,b	2SA777		
Q606a,b Q607a,b	2SC1030		
Q603a,b Q604a,b	2SC1509		
Q608, Q609, Q610			

SWITCH AND VOLUME

- S1a~S1d FUNCTION
 ①AUX ②PHONO ③FM ④AM
 S2a, S2b SPEAKER SELECTOR
 B, A, A+B, OFF,
 S3a,b POWER SW
 S701a,b TAPE ①OFF ②ON
 S702 MODE ①MONO ②STEREO
 S703a,b LOW CUT FILTER ①OFF ②ON
 S704a,b HIGH CUT FILTER ①ON ②OFF

- S705a,b LOUDNESS ①ON ②OFF
 S706 MUTING SW
 S707a,b,c,d, TONE
 VR 901a,b VOLUME CONTROL
 VR 902,903 BASS CONTROL
 VR 904,905 TREBLE CONTROL
 VR 601a,b BIAS ADJUST CONTROL

THIS DIAGRAM APPLIES ONLY TO "SEMCO" MODELS (SHOWN ON REAR PANEL THUS S), FOR POWER SUPPLY MODIFICATIONS, PLEASE REFER TO NEXT PAGE FOR DETAIL OF ANOTHER MODELS.

POWER SUPPLY DIAGRAM FOR THE TWO MODELES

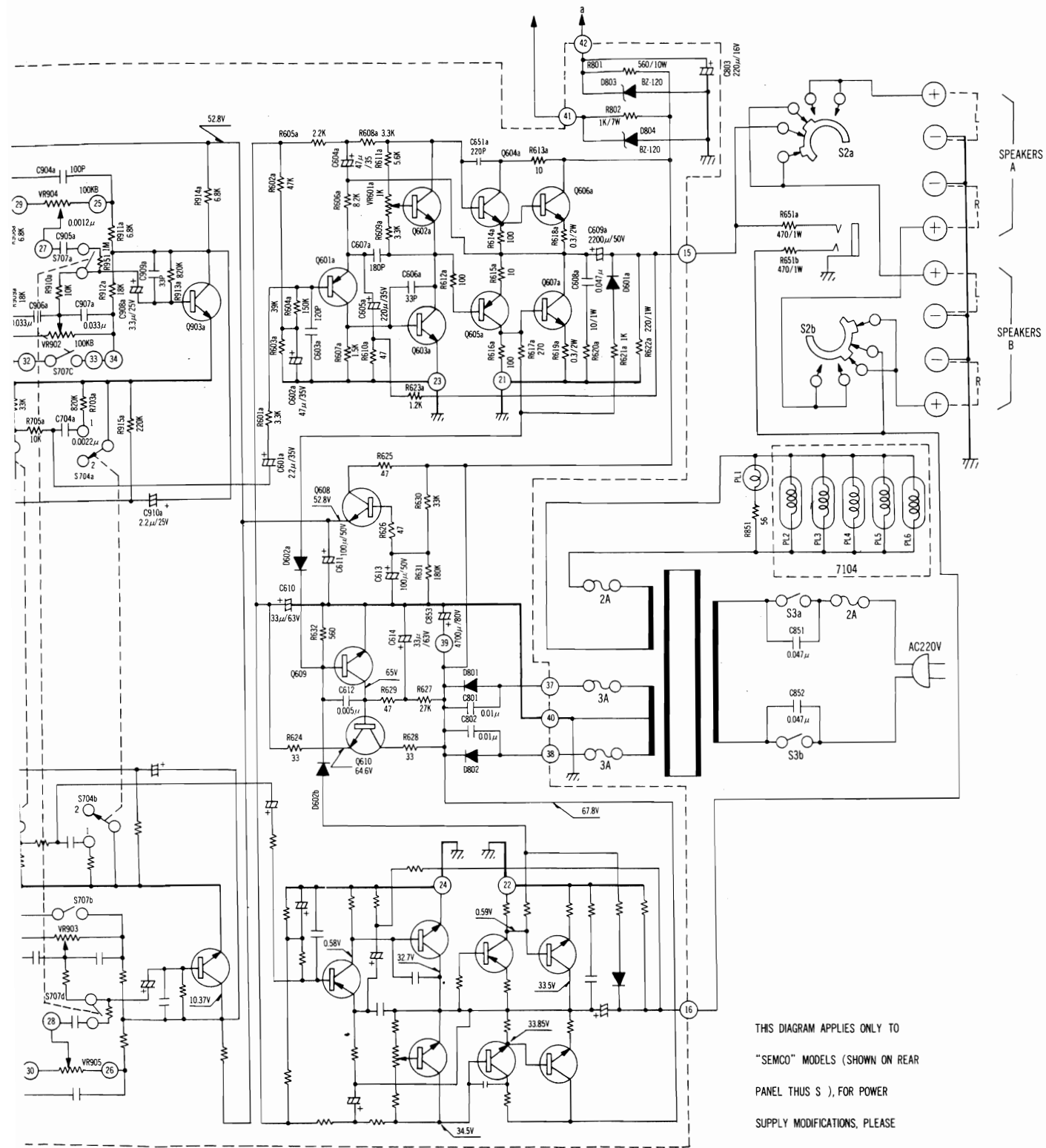

SEMCO MODEL (S)

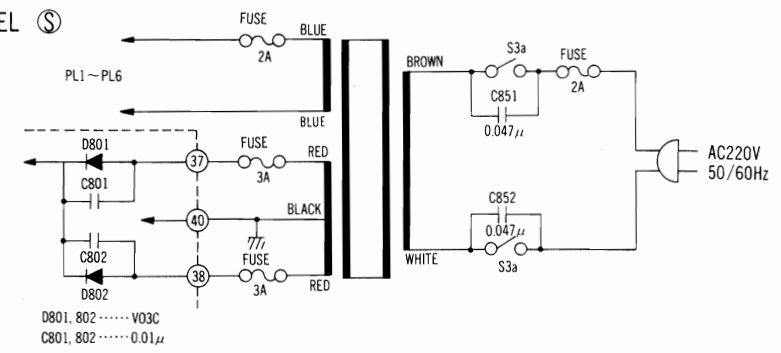

EUROPEAN & CANADIAN MODEL (E)

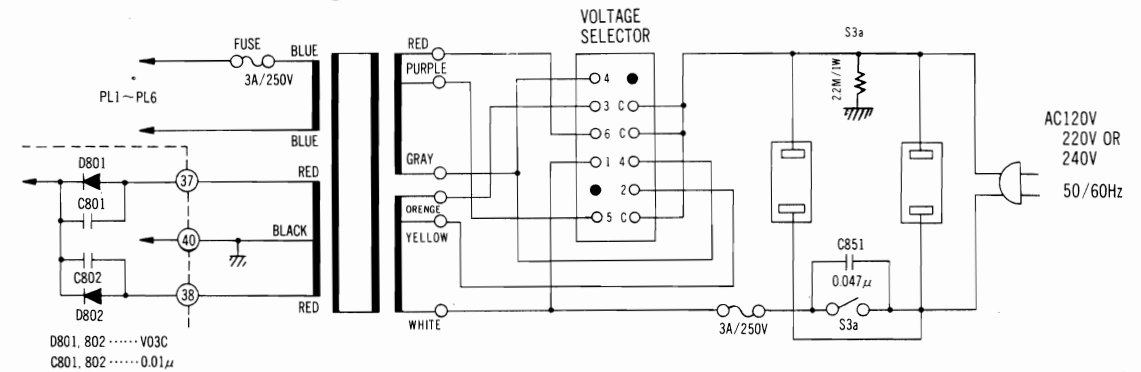

THIS DIAGRAM APPLIES ONLY TO
"SEMCO" MODELS (SHOWN ON REAR
PANEL THUS S), FOR POWER
SUPPLY MODIFICATIONS, PLEASE
REFER TO NEXT PAGE FOR
DETAIL OF ANOTHER MODELS.

WITCH AND VOLUME

- 1a-S1d FUNCTION
①AUX ②PHONO ③FM ④AM
2a, S2b SPEAKER SELECTER
B, A, A+B, OFF,
3a,b POWER SW
701a,b TAPE ①OFF ②ON
702 MODE ①MONO ②STEREO
703a,b LOW CUT FILTER ①OFF ②ON
704a,b HIGH CUT FILTER ①ON ②OFF

- S705a,b LOUDNESS ①ON ②OFF
S706 MUTING SW
S707a,b,c,d, TONE
VR 901a,b VOLUME CONTROL
VR 902,903 BASS CONTROL
VR 904,905 TREBLE CONTROL
VR 601a,b BIAS ADJUST CONTROL

R620 MW & LW IF BOARD ALIGNMENT PROCEDURES

Note: Alignment Procedures of R620 receiver is the same as R600 receiver except for MW & LW IF section

Note: Figures in parentheses are for LW alignment

Step	Signal Source Connected to	Set signal to	Set Radio Dial to	Output Indicator Connected to	Adjust	Adjust for
1	Set selector switch to MW (LW).					
2	Sweep Generator PCB#0023 19 (PCB#4015) through 1uF mylar capacitor	+20 - 25KHz sweep centred at 455KHz generator output level 3mV	Quiet point on band near 600KHz (160KHz)	Oscilloscope P.C.B. #0023 CP-4 (P.C.B. #4015 CP-5)	T401 red core (CF401a red core)	Maximum symmetrical response with flat top Do not adjust for two humps
3					T401 blue core (CF401a blue core)	
4					T402 black core (T401a, T402a)	
5					Adjust VR401 (VR401a) and VR402 (VR402a) to mechanical center position.	
6	AM signal generator Standard radiating loop antenna placed near MW & LW built in antenna	600KHz (160KHz) at 400Hz 30% modulation, field strength 50dB/m	600KHz (160KHz)	Oscilloscope AC VTVM REC OUT	L401 core (L401a core)	Accurate indication of pointer on dial to within ± 1 pointer width Maximum reading on AC VTVM
7					L1 coil (L-2 coil)	
8					TC404a (TC403a)	
9					TC402a (TC401a)	
10	Repeat steps 6-9 as necessary to obtain exact tuning on dial scale and maximum sensitivity.					
11	AM Signal generator standard radiating loop antenna placed near MW & LW bar antenna	1000KHz (240KHz) at 400Hz 30% modulation, field strength* 45dB/m	1000KHz (240KHz)	Oscilloscope AC VTVM REC OUT	VR401 (VR401a)	Audio output level should be 95mV
12					VR402 (VR402a)	

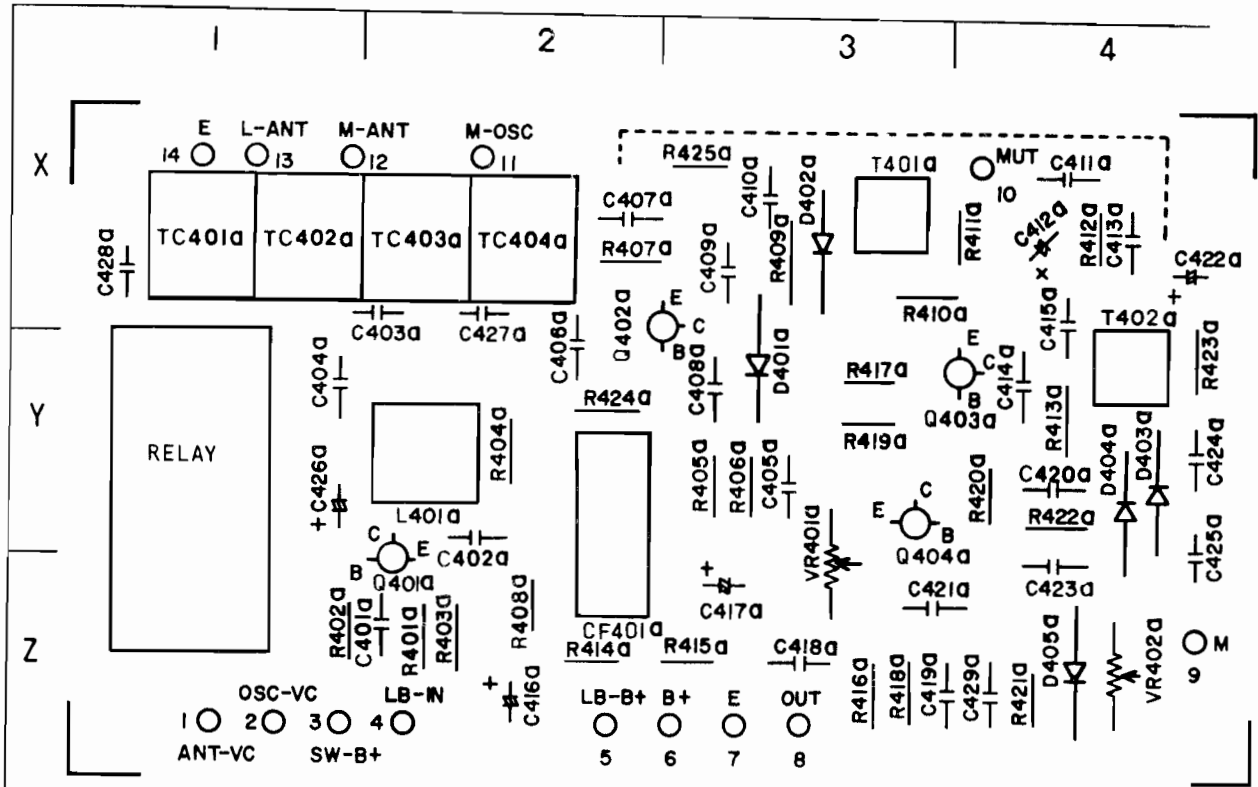

PB4015 Component Location

R401a	Z2	C408a	Y3	D403a	Y4
R402a	Z1	C409a	X3	D404a	Y4, Z4
R403a	Z2	C410a	X3	D405a	Z4
R404a	Y2	C411a	X4	CF401a	Y1, Z2
R405a	Y3	C412a	X4	T401a	X3
R406a	Y3	C413a	X4	T402a	X4, Y4
R507a	X2	C414a	Y4	L401a	Y2
R408a	Z2	C415a	X4, Y4	TC401a	X1
R409a	X3	C416a	Z2	TC402a	X1
R410a	X3	C417a	Z3	TC403a	X2
R411a	X4	C418a	Z3	TC404a	X2
R412a	X4	C419a	Z3	RELAY	Y1, Z1
R413a	Y4	C420a	Y4	(1)	Z1
R414a	Z2	C421a	Z3, Z4	(2)	Z1
R415a	Z3	C422a	X4	(3)	Z1
R416a	Z3	C423a	Z4	(4)	Z2
R417a	Y3	C424a	Y4	(5)	Z2
R418a	Z3	C425a	Y4, Z4	(6)	Z3
R419a	Y3	C426a	Y1	(7)	Z3
R420a	Y4	C427a	X2	(8)	Z3
R421a	Z4	C428a	X1	(9)	Z4
R422a	Y4	C429a	Z4	(10)	X4
R423a	X4, Y4	VR401a	Y3, Z3	(11)	X2
R424a	Y2	VR402a	Z4	(12)	X1
R425a	X3	Q(Tr)401a	Y2, Z2	(13)	X1
C401a	Z2	Q(Tr)402a	X2, X3	(14)	X1
C402a	Y2	Q(Tr)403a	Z4		
C403a	X2	Q(Tr)404a	Y3		
C404a	Y1	D401a	X3, Y3		
C405a	Y3	D402a	X3		
C406a	X1, Y2				
C407a	X2				

REPLACEMENT PARTS OF PB4015 LW IF BOARD

RESISTORS; $\pm 10\%$ $\frac{1}{4}$ Watt deposited carbon, unless noted otherwise

R401a	47K	R410a	15K	R419a	1M
R402a	220K	R411a	4.7K	R420a	18K
R403a	33K	R412a	1K	R421a	18K
R404a	91	R413a	100	R422a	1K
R405a	1K	R414a	1K	R423a	15K
R406a	10K	R415a	100	R424a	68K
R407a	1K	R416a	12K	R425a	68K
R408a	270K	R417a	220		
R409a	3.3K	R418a	56K		

CAPACITORS

C401a	0.02uF	25V $\pm 10\%$	Ceramic	C416a	47uF	16V +50% -10%	Electrolytic
C402a	0.04uF	25V $\pm 10\%$	Ceramic	C417a	100uF	16V +50% -10%	Electrolytic
C403a	75pF	50V $\pm 10\%$	Ceramic	C418a	0.018uF	50V $\pm 10\%$	Polyester
C404a	160pF	50V $\pm 10\%$	Ceramic	C419a	0.033uF	50V $\pm 10\%$	Polyester
C405a	0.04uF	25V $\pm 10\%$	Ceramic	C420a	0.0015uF	50V $\pm 10\%$	Ceramic
C406a	0.02uF	25V $\pm 10\%$	Ceramic	C421a	0.012u	50V $\pm 10\%$	Polyester
C407a	0.04uF	25V $\pm 10\%$	Ceramic	C422a	10uF	16V +50% -10%	Electrolytic
C408a	0.04uF	25V $\pm 10\%$	Ceramic	C423a	0.01uF	25V $\pm 10\%$	Ceramic
C409a	1pF	50V $\pm 10\%$	Ceramic	C424a	0.02uF	25V $\pm 10\%$	Ceramic
C410a	0.02uF	25V $\pm 10\%$	Ceramic	C425a	0.02uF	25V $\pm 10\%$	Ceramic
C411a	0.02uF	25V $\pm 10\%$	Ceramic	C426a	4.7uF	25V +75% -10%	Electrolytic
C412a	47uF	6.3V +50% -10%	Electrolytic	C427a	10pF	50V $\pm 10\%$	Ceramic
C413a	0.04uF	25V $\pm 10\%$	Ceramic	C428a	Not Used		
C414a	1pF	50V $\pm 10\%$	Ceramic	C429a	0.04uF	25V $\pm 10\%$	Ceramic
C415a	0.02uF	25V $\pm 10\%$	Ceramic				

TRANSISTOR & DIODES

Q(Tr)401a	OSC & MIXER	2SC930	D401a	LIMITER	IN60P
Q(Tr)402a	LW IF AMPLIFIER	2SC930	D402a	LIMITER	IN60P
Q(Tr)403a	LW IF AMPLIFIER	2SC930	D403a	DETECTOR	IN60P
Q(Tr)404a	AUDIO AMPLIFIER	2SC1681	D404a	METER DETECTOR	IN60P
			D405a	METER LIMITER	IN60P

VARIABLE RESISTORS

VR401a	20K/B	OUTPUT LEVEL	VR402a	20K/B	METER SETTING
--------	-------	--------------	--------	-------	---------------

VARIABLE CAPACITORS

TC401a	LW ANT TRIMMER	15pF	TC403a	LW OSC TRIMMER	15pF
TC402a	MW ANT TRIMMER	15pF	TC404a	MW OSC TRIMMER	15pF

COIL, CERAMIC FILTER & TRANSFORMERS

L401a	LOCAL OSC COIL	414L	T401a	LW IFT	405B
CF401a	LW IF FILTER	406A	T402a	LW IFT	406D

SWITCH

RELAY	MW-LW VC SWITCHING	AE-1324
-------	--------------------	---------



LUX CORPORATION, JAPAN

1-8-31 NAGAHASHI, NISHINARI-KU, OSAKA
 PHONES: 632 0031 CABLE: LUXELECT OSAKA TELEX: J63694