

 'diamond-dot'

C24P - 1

File: Receivers  
General

CAR RADIO DIVISION, ELECTRONIC INDUSTRIES LTD.

Date: 3-6-70

ASTOR HOUSE: 161-173 STURT ST., SOUTH MELBOURNE - Phone: 69 0300

Page: 1

## SERVICE DATA

# MODEL PN-C24P

PUSH BUTTON 13 TRANSISTOR

12 VOLT NEGATIVE TO CHASSIS CAR RADIO RECEIVER

**Especially designed for Holden Model "HT"**

**WARNING:** BATTERY CONNECTION OF INCORRECT POLARITY WILL DAMAGE THE RECEIVER. BATTERY LEAD OF THESE RECEIVERS MUST BE CONNECTED TO POSITIVE TERMINAL OF SUPPLY. CONNECT NEGATIVE SUPPLY LEAD TO RECEIVER CHASSIS.

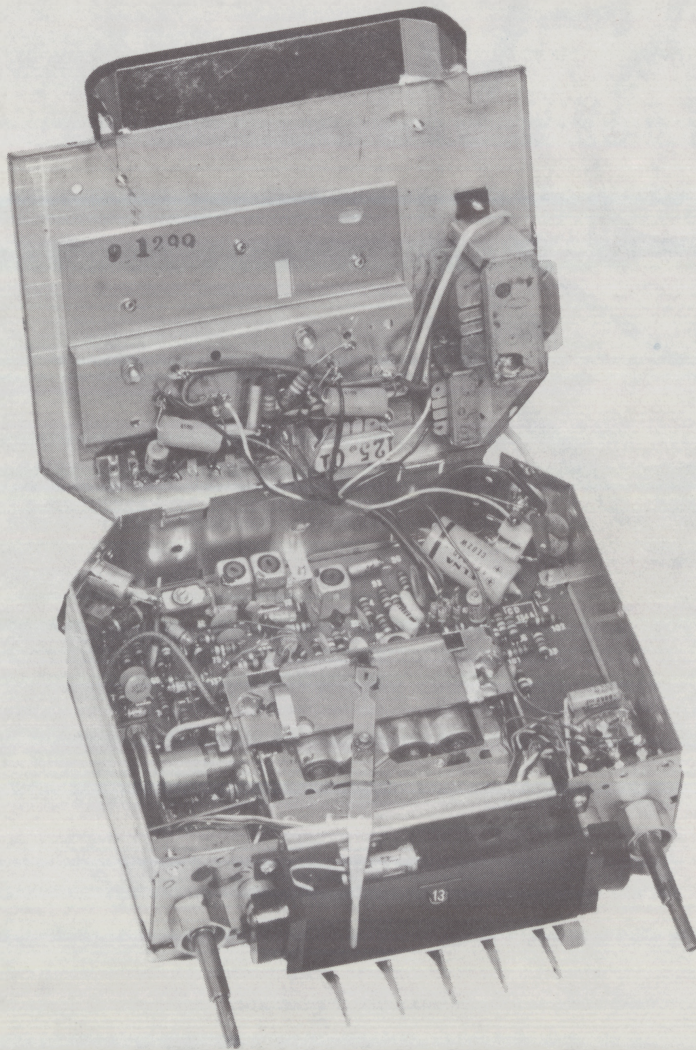

## ALIGNMENT PROCEDURE

### EQUIPMENT

Signal Generator - modulated 400 Hz  
Output Meter - 15 Ohms Impedance  
Generator Series Capacitor - .1uF Part No. 4009-008-20 for I.F. alignment  
I.F. Attenuator - Part No. 4121-014-01  
Dummy Aerial - 65 pF Part No. 4121-009-01  
Alignment Tools:

- (a) Flat Metal Blade Type; Part No. 4121-001-01 for I.F.T. and Osc. shunt coil adjustment.
- (b) Chisel Point Type: Part No. 4121-005-01, for trimmer capacitor adjustment.
- (c) Tuning Unit Iron Core Adjustor: Part No. 4121-008-01
- (d) Alignment Gauge: Part No. 4121-022-02 for tuner 1000 KHz position.
- (e) Clutch Release Bracket: Part No. 4121-029-01, manual model only.

### CONDITIONS

Remove screws and hinge top lid upward.  
Volume control - maximum, clockwise.  
Tone Control - maximum, clockwise.  
Noise Suppression Switch - "OFF" clockwise  
Output Meter Connection - Socket, adjacent to battery lead entry.  
Output Level - 50 Milliwatts, speaker disconnected.  
Supply voltage - 12.0V DC.  
Supply Connection - Connect positive supply lead to receiver lead. Connect negative supply lead to receiver chassis.

### INTERMEDIATE FREQUENCY TRANSFORMER ALIGNMENT

Turn tuning control until cores of tuner unit are out of coil windings. Insert .1uF capacitor in series with generator "hot" lead.

Oper. No.	Generator Connection	Generator Frequency	Instructions
1	To test pin "A" (base of Mixer stage) and return lead to test pin "C" (negative line)	455 KHz	Adjust iron core of 4th IF trans. for maximum output.
2	As oper. 1	455 KHz	Adjust iron core of 3rd IF trans. for maximum output.
3	As oper. 1	455 KHz	Adjust iron core of 2nd IF trans. for maximum output.
4	As oper. 1	455 KHz	Adjust iron core of 1st IF trans. for maximum output.
5	Repeat operations No. 3 and 4 until maximum output is obtained.		

### BROADCAST ALIGNMENT

If the receiver logging is satisfactory the signal circuits may be aligned as detailed.

1	Connect IF. attenuator to test pins "B" and "C" (resistor to pin "C")		
2	Aerial Lead-in Socket -65 pF dummy in series	1000 KHz	Tune receiver to generator frequency. Adjust RF and both aerial trimmer capacitors for maximum output.

### AERIAL TRIMMER ADJUSTMENT

### IMPORTANT

When the receiver has been installed in the vehicle and the aerial connected the aerial trimmer must be readjusted. Raise the aerial to half extended height. Adjust knob on passenger side of receiver for maximum output on a weak station near 1000 KHz (approx. centre of dial) NOTE: If a fully retractable aerial is fitted pull the large outer rod upward against stop in aerial base.



MECHANICAL

Part Number	Description
7111-036-01	Heat Sink (1) power transistors
7111-007-01	Heat Sink (1) temp. comp. transistor Power transistor mounting hardware consists of :
7120-049-01	Gasket (2) mica
7031-036-01	Bush (4) moulded
7198-076-12	Screw (4) 3/8" x 1/8" Whit. cheese head
7262-008-02	Washer (4) 1/8" internal shakeproof
7148-302-11	Nut (4) 1/8" Whit. hex.
7138-070-22	Solder lug (2)
7120-026-01	Insulator (22) glass - transistor, diode and capacitor mount
7167-058-01	Pin (9) circuit board terminations
7060-022-02	Contact (4) circuit board links
7215-095-01	Shield (1) tuner terminals
7027-571-01	Shield (1) leads - top front of tuner
7055-412-01	Contact (4) tuner frame to can
7185-021-02	Retainer (1) battery lead entry
7031-009-01	Bush (1) lead retainer
7222-115-01	Socket body (3) dial lamp
7086-095-02	Contact eyelet (3) lamp socket
7031-146-02	Bush (2) dial lamp socket
7055-532-01	Clip (1) lamp socket
7150-901-03	Spacer nut (2) control bushes
7201-533-11	Screw (15) 1/4" x No. 6 Phillips csk.hd. - various
7204-576-15	Screw (15) 1/4" x No. 4 Phillips pan hd. - various
7224-377-04	Spindles and bush assy. (1) complete, includes tuning and switch spindles, pinion shaft and yoke assy., trunnion, mount bush and circlip
7224-378-01	Pinion shaft and yoke assy. (1)
7407-001-01	Trunnion (1)
7031-066-01	Bush (1)
7055-366-05	Circlip (1)
4077-238-03	Battery lead assy. (1) Consists of :
7244-003-01	Terminal (1) on end of lead
7291-003-01	Shroud (1) terminal
1169-051-04	Lead - yellow - 24 inches required
7091-017-11	Light filter (1) blue - right hand
7091-017-51	Light filter (1) blue - left hand
7005-064-06	Dial background assy. (1) push button
7204-576-15	Screw (4) 1/4" x No. 4 Phillips Hd. - light filters and dial background
7173-056-03	Pointer (1)
7124-285-03	Knob (1) aerial trimmer
7124-366-01	Knob (5) push button
7124-453-01	Knob (2) tuning and volume front
7124-356-01	Knob (2) noise suppression and tone rear
7169-677-02	Dust shield (1)
7070-088-21	Dial reading (1) all state
7070-088-22	Dial reading (1) N.S.W.
7070-088-23	Dial reading (1) Vic.
7070-088-24	Dial reading (1) Qld. and N.G.
7070-088-25	Dial reading (1) Sth. Aust.
7070-088-26	Dial reading (1) W.A. - N.T.
7070-088-27	Dial reading (1) Tas.
7070-088-28	Dial reading (1) Numerical

# C24P-1

## OPERATION OF OUTPUT TRANSISTORS AS MATCHED PAIRS

The type AT1138 transistors are operated in matching pairs, replacements MUST be made accordingly and NOT as single units.

Matched pairs as used in this receiver are identified by a colour dot or stripe or a letter stamped on to the top of the transistor body. Various batch colours or letters are in use. Transistors which have different batch idents. must not be operated together. A matched pair of AT1138 transistors are supplied as:- 2-AT1138 P/No.4128-004-02.

## REPLACEMENT OF OUTPUT TRANSISTORS

When refitting or replacing transistors check that the mount positions and faces are clean and free from dust, grit or metal particles.

**NOTE:** A power transistor replacement hardware package, Part No. 7001-104-01, containing screws, nuts, washers, bushes and mica gaskets is available from Spare Parts Division.

Fit the insulating bushes to the screw holes then fit mica gasket and transistor. Fasten each transistor with 3/8" x 1/8" Whit.screws, lugs, shakeproof washers and 1/8" Whit. nuts. Securely tighten.

## OPERATION OF DRIVER TRANSISTORS AS MATCHED PAIRS

The type AT436 transistors are operated in matched pairs, replacements MUST be made accordingly and NOT as single units.

Matched pairs as used in this receiver are identified by a batch number printed on the side of transistor housing. Transistors with different numbers must not be operated together.

A matched pair of AT436 transistors are supplied as :- 2-AT436, Part No. 4128-167-01.

## MEASUREMENT AND ADJUSTMENT OF OUTPUT TRANSISTORS COLLECTOR CURRENT

**EQUIPMENT** Current Meter: 0-1 Amp D.C. terminated with a lead and clip assy.  
Supply Source: 13.0V DC.

**CONDITIONS** Connect supply leads, negative lead to receiver chassis. Connect speaker to receiver socket adjacent to battery lead entry. Disconnect lead 'D' from pin 'E'. Connect current meter to lead 'D' and pin 'E'. Current meter positive terminal to lead 'D'. No signal applied to aerial socket.

1. Switch receiver "ON" and allow to stabilize for at least five minutes.
2. Adjust the bias potentiometer (Circuit No. 100) to obtain a reading of 150mA.

**NOTE:**No further adjustment of the bias should be necessary unless the output or driver transistors or associated componentry are replaced.

## CONNECTION OF A FADER CONTROL FOR USE WITH FRONT AND REAR SPEAKERS

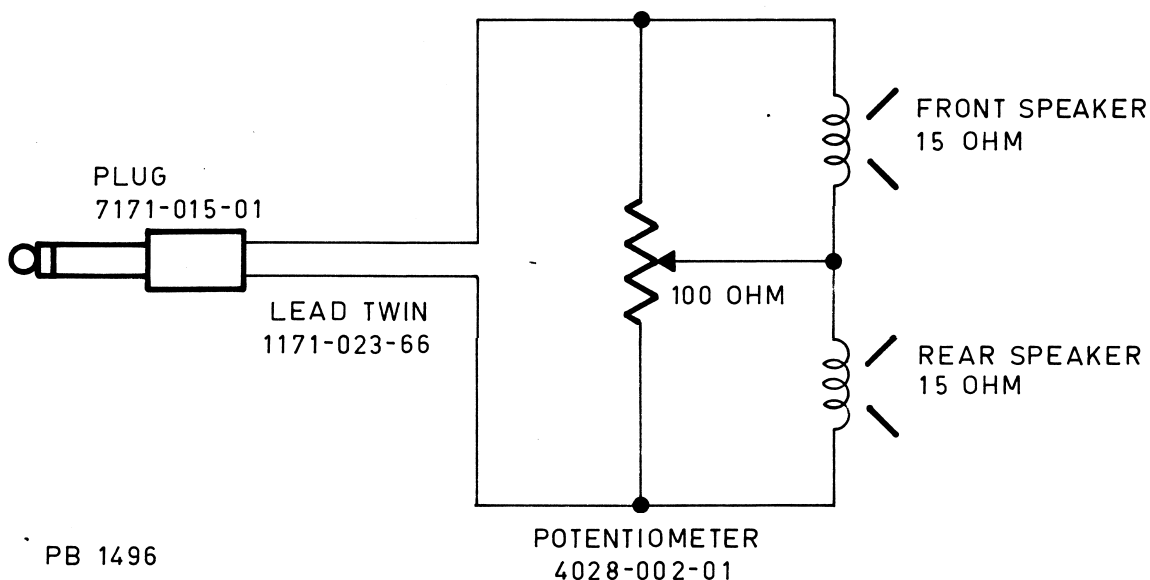

CAPACITORS

Circuit No.	Value	Description	Tol ±	Rating V.DCW	Part Number
1	12-120 pF	Trimmer - compression			4000-026-02
2	5-55 pF	Trimmer - compression			4000-001-03
3	.0047 uF	Polystyrene	10%	50	4004-019-07
4	82 pF	Polystyrene	10%	100	4004-020-01
5	4.7 pF	Ceramic Disc - NPO	.5 pF	500	4008-042-02
6	5 uF	Electrolytic		3	4005-018-17
7	.47 uF	Ceramic disc		3	4008-059-02
8	.047 uF	Ceramic disc		25	4008-057-03
9	5-55 pF	Trimmer - compression			4000-001-03
10					
11	680 pF	Polystyrene	10%	100	4004-016-02
12	100 pF	Polystyrene	10%	100	4004-008-06
13	.001 uF	Polystyrene	10%	50	4004-001-09
14	.022 uF	Ceramic disc		25	4008-010-03
15	.022 uF	Ceramic disc		25	4008-010-03
16	.047 uF	Polyester	20%	160	4009-001-25
17	220 pF	Polystyrene	5%	100	4004-005-03
18	2.7 pF	Ceramic disc - NPO	.25 pF	500	4008-013-01
19	56 pF	Polystyrene	10%	100	4004-025-02
20					
21	.0068 uF	Polyester	20%	160	4009-004-16
22	220 pF	Polystyrene	5%	100	4004-005-03
23	.047 uF	Polyester	20%	160	4009-001-25
24	5.5-65 pF	Trimmer			4000-057-01
25	.047 uF	Polyester	20%	160	4009-001-25
26	.047 uF	Polyester	20%	160	4009-001-25
27	.047 uF	Polyester	20%	160	4009-001-25
28	220pF	Polystyrene	5%	100	4004-005-03
29	4 uF	Electrolytic		40	4005-045-02
30					
31	30 uF	Electrolytic		12	4005-033-08
32	.047 uF	Polyester	20%	160	4009-001-25
33	.1 uF	Polyester	20%	160	4009-008-31
34	.047 uF	Polyester	20%	160	4009-001-25
35	.047 uF	Polyester	20%	160	4009-001-25
36	220 pF	Polystyrene	5%	100	4004-005-03
37	.0022 uF	Polyester	20%	400	4009-002-14
38	.0022 uF	Polyester	20%	400	4009-002-14
39	.0068 uF	Polyester	10%	270	4009-004-07
40					
41	.1 uF	Ceramic disc		25	4008-004-04
42	.033 uF	Polyester	10%	160	4009-019-08
43	.33 uF	Polyester	10%	160	4009-005-14
44	.001 uF	Ceramic feed thru			4008-040-08
45					
46	.047 uF	Polyester	10%	160	4009-001-15
47	.47 uF	Ceramic disc		3	4008-059-02
48	10 uF	Electrolytic		16	4005-007-22
49	100 pF	Polystyrene	10%	100	4004-008-06
50	30 uF	Electrolytic		12	4005-033-08
51	5 uF	Electrolytic		12	4005-018-15
52	.1 uF	Polyester	10%	160	4009-008-20
53	.1 uF	Polyester	10%	160	4009-008-20
54	640 uF	Electrolytic		16	4005-046-04
55	.047 uF	Ceramic disc		25	4008-057-04
56	.047 uF	Ceramic disc		25	4008-057-04
57	.001 uF	Ceramic feed thru			4008-040-08
58	.0068 uF	Polyester	10%	270	4009-004-07
59	100 pF	Polystyrene	10%	100	4004-008-06

RESISTORS

Circuit No.	Value Ohms	Description	Tol + -	Rating Watts	Part Number
60					
61	1K	Carbon	10%	.5	4022-008-01
62	150K	Carbon	10%	.5	4022-038-01
63	220	Carbon	10%	.5	4022-047-01
64	4.7K	Carbon	10%	.5	4022-005-01
65	560	Carbon	10%	.5	4022-010-01
66	1K	Carbon	10%	.5	4022-008-01
67	2.7K	Carbon	10%	.5	4022-043-01
68	220K	Carbon	10%	.5	4022-063-01
69	1K	Carbon	10%	.5	4022-008-01
70	4.7K	Carbon	10%	.5	4022-005-01
71	8.2K	Carbon	10%	.5	4022-027-02
72	5.6K	Carbon	10%	.5	4022-022-02
73	10K	Carbon	10%	.5	4022-004-01
74	1.5K	Carbon	10%	.5	4022-007-01
75	150K	Carbon	10%	.5	4022-038-01
76	47K	Carbon	10%	.5	4022-051-03
77	220K	Carbon	10%	.5	4022-063-01
78	22	Carbon	10%	.5	4022-033-01
79	1K	Carbon	10%	.5	4022-008-01
80	6.8K	Carbon	10%	.5	4022-002-02
81	1.5K	Carbon	10%	.5	4022-007-01
82	68K	Carbon	10%	.5	4022-048-01
83	10K	Carbon	10%	.5	4022-004-01
84	4.7K	Carbon	10%	.5	4022-005-01
85	15	Carbon	10%	.5	4022-053-01
86	390	Carbon	10%	.5	4022-058-04
87	100	Carbon	10%	.5	4022-062-01
88	1K	Carbon	10%	.5	4022-008-01
89	4.7K	Carbon	10%	.5	4022-005-01
90	680	Carbon	10%	.5	4022-028-02
91	4.7K	Carbon	10%	.5	4022-005-01
92	47	Carbon	10%	.5	4022-041-01
93	12K	Carbon	10%	.5	4022-029-01
94	4.7K	Carbon	10%	.5	4022-005-01
95	1K	Carbon	10%	.5	4022-008-01
96		Volume and Tone Controls Concentric shaft potentiometer front section 50K ohm Rear section 50K ohm tapped at 20K ohm S.P.S.T. push-push switch attached			4030-030-13
97	15K	Carbon	10%	.5	4022-001-02
98	100K	Carbon	10%	.5	4022-013-02
99	100K	Carbon	10%	.5	4022-013-02
100	220	Potentiometer - preset	20%		4025-034-02
101	2.2K	Carbon	10%	.5	4022-021-02
102	1K	Carbon	10%	.5	4022-008-01
103	4.7K	Carbon	10%	.5	4022-005-01
104	68	Carbon	10%	.5	4022-024-01
105	1K	Carbon	10%	.5	4022-008-01
106	15K	Carbon	10%	.5	4022-001-02
107	150	Carbon	10%	.5	4022-052-01
108	220	Carbon	10%	.5	4022-017-01
109	47	Carbon	10%	.5	4022-041-01
110	68	Carbon	10%	.5	4022-024-01
111	47	Carbon	10%	.5	4022-041-01
112	.27	Wire wound	10%	.5	4024-007-02
113	.27	Wire wound	10%	.5	4024-007-02
114	47	Carbon	10%	1	4022-041-03
115					
116					
117					
118					
119					

BROADCAST ALIGNMENT

When iron cores or tuning unit coil assy. have been replaced or if station logging is outside limits.

Oper. No.	Generator Connection	Generator Frequency	Instructions
1	Connect IF attenuator to test pins "B" and "C" (resistor to pin "C")		
2	Turn perm. tuner against high frequency end of travel stop. Set all iron cores so that no less than 1/8" of shaft protrudes out through front panel of receiver.		
3	To aerial Lead-in Socket 65 pF dummy aerial in series	1625 KHz	Adjust Osc. RF and both aerial trimmer capacitors for maximum output.
4	<u>PUSH BUTTON RECEIVER:</u> Partly push in one of the push button knobs to release clutch before inserting gauge.		
	<u>MANUAL RECEIVER:</u> Disengage clutch at crown wheel by utilizing clutch Release Bracket, before inserting gauge.		
	In the side of tuning unit, opposite end to tuning spindle there are two slots; place the notched blade of gauge into the slot nearest rear of tuner. The 0.39" section of gauge is to be against the projection at front edge of slot. Spring fingers of gauge are to be at rear of tongue. Refer diagram.		
<u>NOTE:</u>	Do not strain or tilt core carriage.		
	As oper. 3	1000 KHz	With tuner set in position detailed, adjust Osc., RF and both Aerial iron cores for maximum output.
5	As Oper. 3	600 KHz	Rock tuning control through signal, adjust Osc. shunt coil for maximum output.
6	Turn tuning control to low frequency end of travel (iron cores full in.) Tune signal generator to receiver. The low frequency tuning limit should be between 510 and 528 KHz.		
7	Repeat operation 4.		
8	Align dial pointer.		

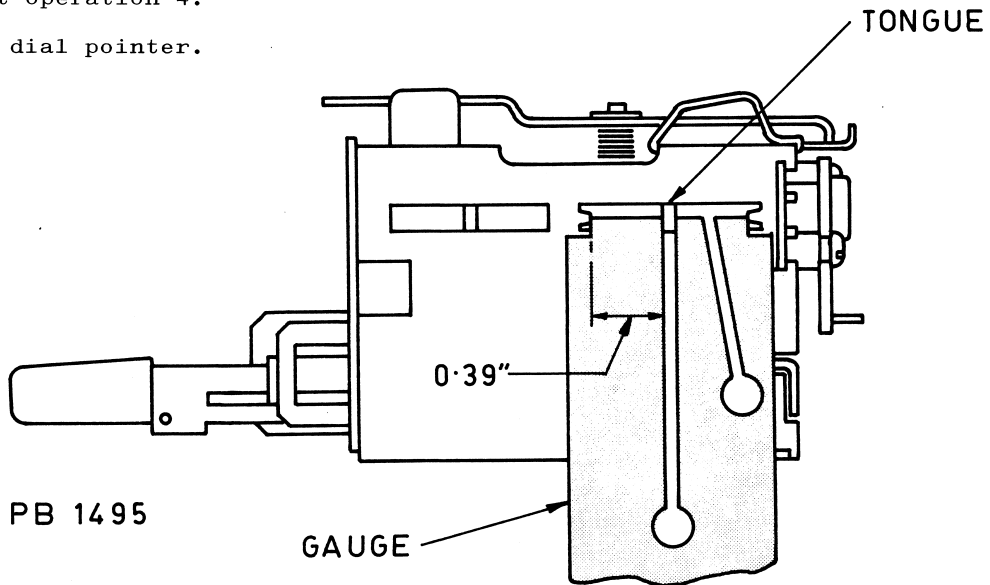

SETTING OF DIAL POINTER

Disconnect the IF attenuator.  
 Disconnect the generator cable from dummy aerial then connect 20 ft., of aerial wire to the dummy aerial terminal.  
 Accurately tune the receiver to a station marked on the dial near 1000 KHz.  
 Using a screwdriver, adjust by bending the pointer carriage arm so that the pointer coincides with the centre of the tuned station call sign.

Check dial logging and if necessary readjust pointer carriage arm.

MISCELLANEOUS

Circuit No.	Description	Part Number
120		
121	Choke - 6.8 uH	4048-032-01
122	Permeability Tuner Unit - complete	
	PUSH BUTTON	4050-047-05
	This tuner consists of the following :	
	Iron Sleeve (3)	4065-037-01
	Iron Sleeve (1) oscillator.	4065-038-01
	Iron core (4)	4065-039-02
	Coil assy.	4036-053-01
	includes:	
	Aerial coil	4036-057-01
	Aerial transformer	4043-033-01
	R.F. coil	4036-057-01
	Oscillator transformer	4043-033-01
123	No. 1 I.F. Transformer - yellow/black	4044-032-01
124	No. 2 I.F. Transformer - yellow/green	4044-032-02
125	Oscillator shunt coil	4036-044-02
126	No. 3 I.F. Transformer - yellow/blue	4044-032-03
127	No. 4 I.F. Transformer - yellow/violet	4044-032-04
128		
129	Choke - iron core	4048-025-05
130	Driver transformer	4042-125-01
131	Speaker transformer	4042-128-01
132	Choke - speaker filter	4048-043-02
133	Speaker - type C96L36/69/15	4056-004-18
134		
135		
136	Transistor - Type AT320 - R.F. amp	4128-199-01
137	Transistor - Type AT321 - Mixer	4128-119-01
138	Transistor - Type AT321 - Oscillator	4128-119-01
139	Transistor - Type AT321 - I.F. amp	4128-119-01
140	Transistor - Type BF184 - I.F. amp	4128-178-01
141	Transistor - Type AT330 - Voltage Regulator	4128-168-01
142	Transistor - Type AT337 - Audio amp	4128-133-01
143	Transistor - Type AT337 - Audio amp	4128-133-01
144	Transistor - Type 2 - AT436 Matched pair - Audio Driver	4128-167-01
145	Transistor - Type AC125 - Temperature compensation	4128-039-01
146	Transistor - Type 2 - AT1138 Matched pair - Audio Output	4128-004-02
147	Diode - Type 1N60A - Detector	4127-032-01
148	Plug - Speaker lead	7171-015-01
149	Aerial socket	7222-037-01
150	Noise suppression switch	4059-187-01
151	Indicator and dial lamp	4068-003-04
152	Indicator and dial lamp	4068-003-04
153	Noise suppressor indicator lamp	4068-003-04
154	Fuse - 3 Amp	4071-010-02
155	Speaker Socket	7222-033-11
156	ON/OFF switch - part of volume control	



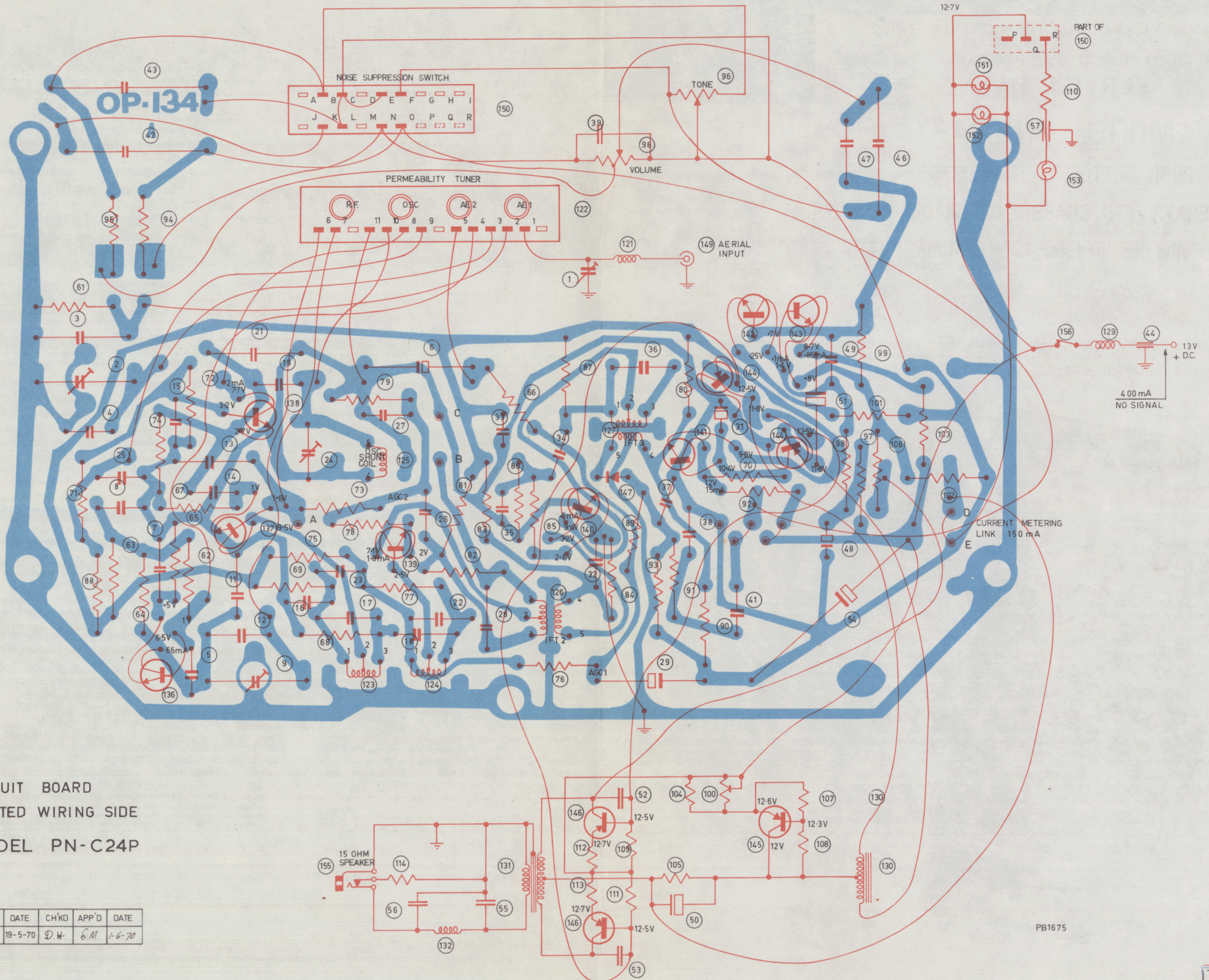

CIRCUIT BOARD  
 PRINTED WIRING SIDE  
 MODEL PN-C24P

DRAWN	DATE	CHK'D	APP'D	DATE
A. O.	19-5-70	D. W.	E. M.	1-6-70



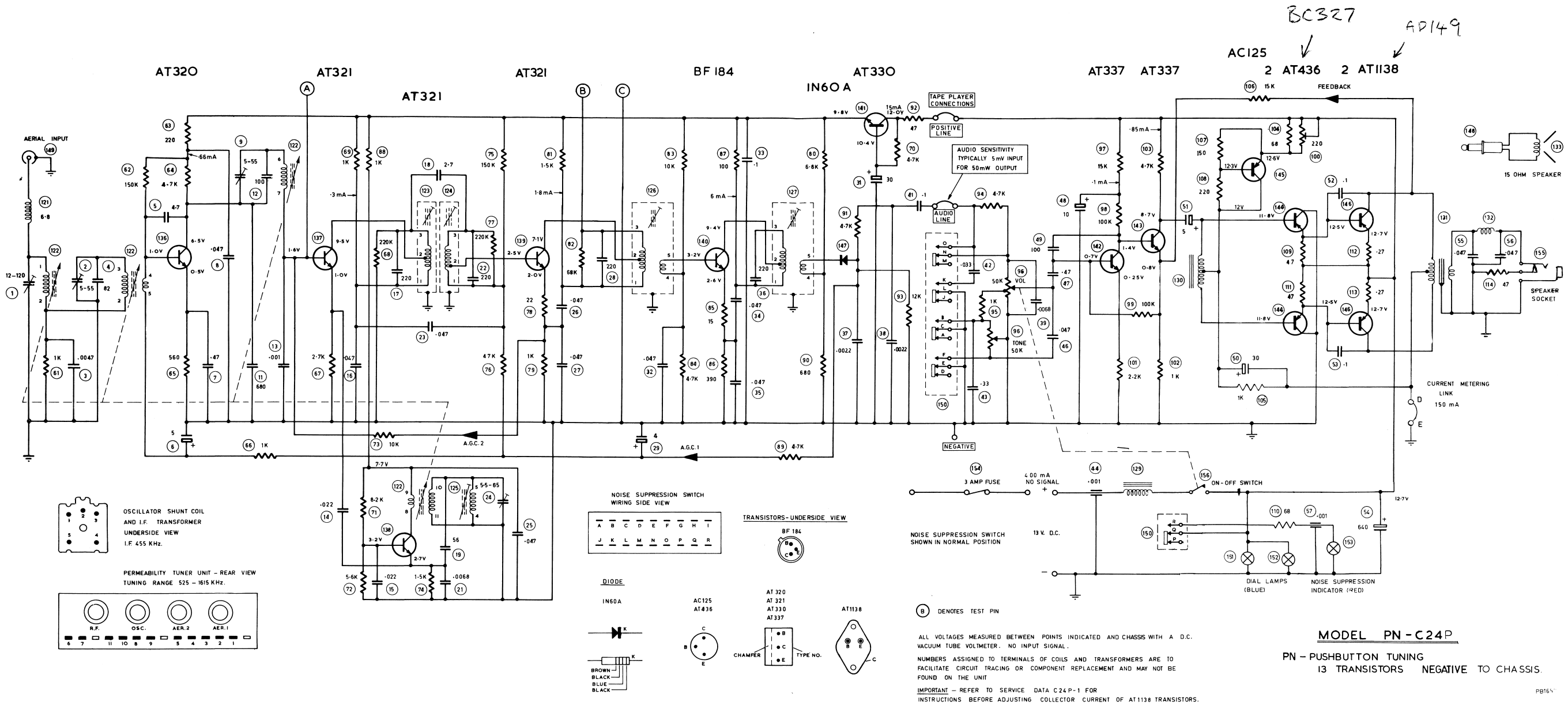

BC327  
AD149

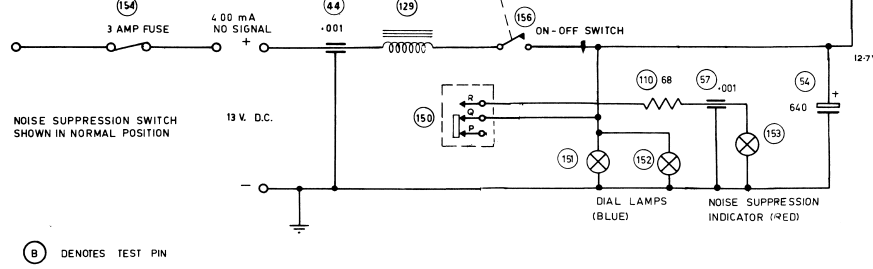
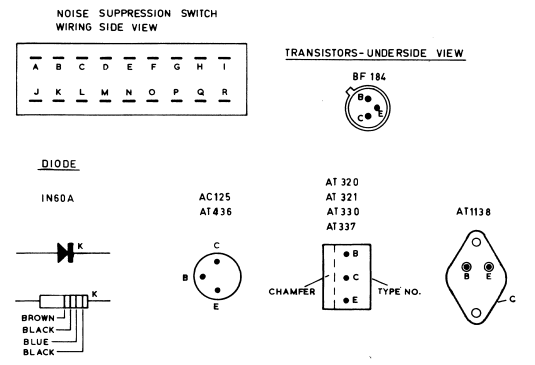
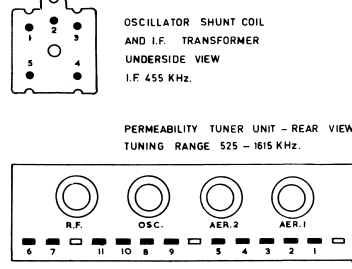

**MODEL PN-C24P**  
PN - PUSHBUTTON TUNING  
13 TRANSISTORS NEGATIVE TO CHASSIS.

ALL VOLTAGES MEASURED BETWEEN POINTS INDICATED AND CHASSIS WITH A D.C. VACUUM TUBE VOLTMETER. NO INPUT SIGNAL.  
NUMBERS ASSIGNED TO TERMINALS OF COILS AND TRANSFORMERS ARE TO FACILITATE CIRCUIT TRACING OR COMPONENT REPLACEMENT AND MAY NOT BE FOUND ON THE UNIT  
**IMPORTANT - REFER TO SERVICE DATA C24P-1 FOR INSTRUCTIONS BEFORE ADJUSTING COLLECTOR CURRENT OF AT1138 TRANSISTORS.**

DRAWN	DATE	CHK'D	APP'D	DATE
[Signature]	22-5-69	[Signature]	[Signature]	21-10-69

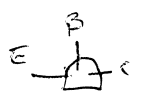

- Tuning Range : 525-1630 KHz approx.
- Intermediate Frequency : 455 KHz
- Supply Voltage : 13.0 Volts D.C.
- Current Consumption : 400 milli Amps
- Power Output : 8 Watts
- Speaker Impedance : 15 ohms

**SETTING THE PUSH BUTTONS**

1. Unlock the push buttons by pulling outward.
2. Tune a desired station with the manual tuning knob.
3. Press one of the push buttons fully in.
4. Repeat the above procedure to set remaining four buttons.