

INTEGRATED
AMPLIFIER



SEPARATE
AMPLIFIER



VACUUM TUBE
AMPLIFIER



ANALOG
PLAYER



DIGITAL
PLAYER



OTHERS





Performance with Emotion for Audiophiles and Music Lovers

Music as an Expression of Human Emotion

Since the beginning of human history, music has played an integral part in communicating emotions and expressions. Music has always been considered as a means of expressing profound feelings and emotions, not merely a natural phenomenon. Music led to the invention of instruments, which were created and refined to achieve still higher levels of expressions. This evolutionary process has resulted in productive interaction among instrument, composers and musicians; take Stradivarius violins for example.

Stradivarius was an Italian craftsman who perfected the art of violin making by experimenting with new shapes, materials and finishes. In his lifetime he made 1,116 violins, of which an estimated 540 have survived until today. His creations have been the source of inspiration for many musicians and composers. In the 200 years since Stradivarius' death, nobody has succeeded in making a violin with a comparable sound, despite the tremendous technological progress achieved during this interval.

The same analogy applies to audio engineers. There have been numerous technological revolutions in the past decades, allowing music lovers to enjoy music practically anywhere and anytime. Indeed, for most of us music is now an indispensable everyday amenity. Explosive development in digital engineering has led portable systems to dominance in the market, having evolved from simple clockwork to complex circuitry, promising better functionality and convenience than ever before. These systems may exhibit superior technological performance, but they are no match for a Stradivarius' violin when it comes to evocative and emotional power.

Unmask the Tonal Colors of your Favorite Recordings to Feel Every Note

Audio components are industrial products that make use of state-of-art electronics. Performance specifications must meet a certain standard, though the equipment boasting the best specifications is not necessarily the one that offers the highest sound quality. The deep emotion and serenity invoked as music is played back should be similar to the emotions that paintings and sculptures create in their viewers. It is in the pursuit of such eloquent and subtle musical expression that we at Luxman strive to incorporate into our audio components. Of course there is no way to quantify the emotions and sense of involvement that music evokes in the listener as it is played by an audio component. So at Luxman we call upon a group of experienced engineers who share a love for music.

As experts in electronics, material physics, and of course music itself, they design and build every one of our products with dedication and passion, placing great emphasis on external appearance, design and color scheme, as well as the pride of ownership. The audio components we manufacture are products of cultural expression intended to appeal to the sensitivity of the enthusiast, to provide intellectual and spiritual fulfillment. When these 'sensual' elements work together, that's when we can truly boast of Luxman's history of achieving a perfect marriage of form & function.

Bring your Own Music and Savor Our Music

To fully comprehend our philosophy of audio as a past time to fuel the feed your passion for music, you need to sharpen your audio palette, and cultivate your sense overtime. Gourmets want to eat outstanding cuisine in a comfortable ambiance while enjoying attentive service. They strive to derive as much satisfaction as possible from the act of eating. Become a sound gourmet. Experience the complete sensual satisfaction that only a Luxman product can give.

Luxman's Aesthetic Mobile – The Interplay with Light and Shadow

At Luxman, we believe each audio component should have its own unique personality. When designing a product our engineers consider its shape, contours, colour, feel and other sensual properties. The principal design motif of our products and reason they feature a sculpture – like profile, is what we call interplay of 'light and shadow' .

The concept can be thought of in terms of a mobile. A mobile gives the viewer different impressions in the light of spring and autumn even if the light is of the same absolute intensity. It looks different when you see it against an intense light source. And if the light comes from the left, shadows appear to the right of an object, giving a different impression from when the object casts shadows to the left.

Similarly, each Luxman audio component has a personality of its own which changes its mood to mirror the emotions felt by the listener.

That is why our product designs are enduring and endearing. The SQ-38u is a good example, here is a product that has gone through eleven generations over the past 45 years, but is still recognizable from the original unit produced in 1964.

Luxman's Performance Engine for Powerful, Natural, Organic and Wholesome Sound

A piece of audio equipment should offer excellent performance specifications. Yet the product that performs the best on paper is not necessarily the best sounding one. There is no way to relate specs to the degree of emotions a product evokes in the heart of the listener.

While we at Luxman place a great importance on numerical analysis of our products, an even greater significance is given to actual auditions. In essence, our performance concept is to ensure that a component produces the most natural sound possible when it plays back music.

Our senses are quick to detect unnaturalness in what we hear. Artificial sound tires us, but rich, natural sound relaxes and frees us from stress and tension, letting us enjoy music at the deepest level.

The next step is to examine carefully every technical aspect, using rigorous test methods to ensure reliability of performance. This is followed by devising ways to overcome mutual interference, partial resonance and other causes of sound degradation. Finally, we subject the product to critical fine-tuning for optimal sound quality. Here Luxman's 85 years of experience and know-how are put to full use.

Luxman's Legacy

Audio was born 130 years ago, when Edison made the first sound recording. Today, thanks to the innumerable technological innovations achieved since, audio made it possible to perpetuate legendary performances in the highest sound quality imaginable. Audio allows you to enjoy such moments over and over – forever.

At Luxman we strive to provide equipments capable of playing back our recorded cultural heritage with such fidelity and emotion as to take listeners into new dimensions of musical excitement & appreciation.

Open to innovative ideas and free from engineering prejudices; Luxman is committed to designing and building heirloom products that satisfy audiophiles & music lovers alike and can be inherited by the next generations to come.

FOR UPPERMOST TONE QUALITY

C-900u

Balanced Control Amplifier



C-900u was newly created for the pursuit of the uppermost tone quality. The balanced amplification circuit having 4-module configuration in which the right/left and HOT/COLD of sound signals are set to be independent is introduced to suppress unnecessary noise generation. Combination of the evolved traditional ODNF circuit version 4.0 and powerful power supply unit has achieved high S/N performance sound quality without distortion. Luxman's original fixed resistance switching type attenuator, the latest version of "LECUA 1000", is used for the volume adjustment mechanism that is the major key of the control amplifier. The number of contacts is set to 88 to allow the more precise volume adjustment to be performed. This product is appropriate for calling the modern control center because of its elegant design with user-friendliness, the tone control function, premium operation feeling, and more.

New LECUA 1000 with fully balanced configuration, attenuator with discrete configured ODNF amplifier directly coupled



It can be said that the volume adjustment function is the core of a control amplifier. C-900u has been equipped with the high-precision attenuator that is electronically controlled and is switched by fixed resistance, which has been used in the Luxman's 80th anniversary flagship model, C-1000f, and also with the new LECUA 1000 that has been evolved from the amplification circuit integrated type, LECUA*1000. This type is extremely insensitive to external vibration and change in sound quality depending on sound volume positions, and also significantly excellent in durability. Increase in the number of steps from 72 to 88 allows more delicate sound volume to be adjustable without deterioration of sound quality within 0 to 87dB. The completely balanced configured C-900u is equipped with 4 units of these new LECUA 1000s in parallel, which has achieved ideal balanced transmission. Because LECUA 1000 control is used for balance adjustment between right and left and level adjustment in the bi-amplifier output mode, there is no need for concern about the deterioration of sound quality. In addition, 3D layout is introduced in new LECUA1000 to allow substrates to be placed in three dimensions, and the attenuator circuit is directly connected to back to the amplification circuit to maximize the advantage of the NFB (negative feedback), and

the primary slew rate speed indicating the startup performance, ultra-wide bandwidth, and the latest version of the ODNF* circuit that has achieved lower distortion are adopted. The ODNF circuit version 4.0 has acquired higher performance by making the first stage of the main amplifier 4 parallels, second stage Darlington connection, and the first stage of the error detection amplifier 3 parallels. Delicate sound expression can be achieved by improving the S/N performance with the amount of feedback minimized, especially improving distortion characteristics at high frequencies remarkably. We have paid special attention to the shape, weightiness, and texture of the volume knob and pursued natural high quality feeling for it because the knob has the most opportunities to be touched by the user.



Large-capacity CI type transformer and digital circuit dedicated transformer

Large-capacity high-inertia power supply circuit

The high-performance power supply circuit is configured, which consists of the CI type power transformer whose capacity is equivalent to the monaural power amplifier, B-1000f, for the voltage amplification stage under the philosophy of "Power Amplifier Deriver" the drives the connected power amplifier precisely with sufficient power and a large-capacity block capacitor of 3,300 μ F x 4 units. The delicacy and powerfulness of sound signals are transmitted to the power amplifier with the support of the high-inertia power supply with remarkably high stability and almost no small voltage fluctuation.



At normal

At zoomed

Compatibility between user-friendliness and multifunction

C-900u has been equipped with user-friendliness, flexibility, and expandability in accordance with system environment as well as multifunction. The FL display with high visibility can usually display inputs and sound volume in a 2-stage fashion, and also zoom in the contents 4 times larger with the remote control operation. This unit is equipped with the bi-amplifier output mode in which a balanced circuit can be used as a 2-channel unbalanced output, the external pre-amplifier input that is useful for coexistence with an AV system, and the tone control electronically controlled for sound quality.



Gradation cast-iron insulator leg

Highly rigid cabinet covered with blasted white

Highly rigid loopless chassis is used for the cabinet to eliminate ground loop that causes the deterioration of sound quality. Gradation cast-iron is selected for the legs to prevent resonance thanks to its characteristics of that the metallic structure becomes smaller from the center to the periphery of the leg. The legs eliminate adverse effects on the circuit parts caused by vibration from the power transformer or mounting surface. The blasted white exterior with no viewable structural screw adds a sense of high quality and dignified presence.



Dedicated remote control (RA-20)

Aluminum remote control with moderate weightiness

The remote control to be frequently used is made of aluminum with moderate weightiness. The remote control allows the user to operate a wide variety of functions of C-900u in a centralized manner with remaining seated to perform sound volume adjustment as a matter of course, the loudness function that automatically provides optimal balance adjustment in an auditory sensation according to sound volume, balanced phase presetting that can be set for each input system, the display dimming function (brightness switching), the zoom function that can be operated from some distance, and more.

TO BRING OUT THE BEST SOUND EXPRESSION

M-900u

Stereo Power Amplifier

The stereo power amplification, M-900u, has been created to bring out the best sound expression from the speaker system. The rich gradation sound quality has been achieved from deep bass sound to clear high tone with sufficient drive force acquired by connecting the 4-parallel push-pull structural output units in parallel. Luxman's original ODNF circuit that provides both a lively feeling and ultra-low distortion has been evolved to the latest version 4.0. The transparent large analog meter produces the enjoyment of listening to music with finesse, and the exterior design with blasted white finishing encloses high power gently. The BTL connection allows the user to use the unit as an ultra-high power monaural amplifier of 600W (8Ω).



High power ODNF amplifier with 4x2 output structure, which has achieved overwhelming power linearity of up to 1,200W (1Ω)

The role of the power amplifier is to amplify sound signals from the control amplifier in faithful accordance with inputs and to vibrate the speaker units precisely. To perform these tasks, the great drivability and firm linearity of the output circuit are essential. M-900u has not only acquired sufficient rated output of 150 W +150W (8Ω), 300W +300 W (4Ω) but also achieved instantaneous maximum output of up to 1,200W+1,200W (1Ω). Therefore, the unit can be ready with leeway for a sound source that requires high energy in a moment and drive speakers in any circumstances without being affected by change in speaker impedance. In addition, the BTL connection allows the user to use the unit as a monaural amplifier with the rated output of 600 W (8Ω). For the circuit configuration with this mighty power, 1 module of 3-stage Darlington and 4-parallel push-pull amplification circuit that is most excellent in sound quality according to our experiences of amplifier development for a long time and 4x2 output in which 2 modules are combined per a channel are used. The effect of the counter electromotive force from a speaker is suppressed by maintaining the damping factor to 710, and overwhelming power linearity to drive the speaker unit is achieved.

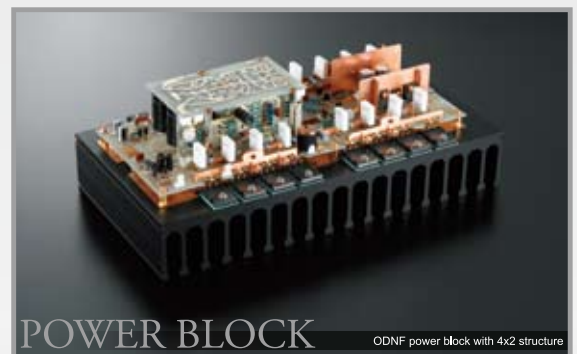

The latest version, 4.0, of the ODNF circuit that performs feedback of only distortion components is introduced to the amplification circuit. Then, both the merits of NFB (negative feedback), i.e. low distortion and wide-band characteristics, and the features of a non-feedback amplifier, i.e. quick response and natural tone quality are provided. The ODNF circuit version 4.0 has the improved accuracy of detecting distortion with use of 3 parallels of the first stage of the error detection amplifier. The expressive power of silence has been improved and the sound emotion is finely and heavily expressed by minimizing the feedback amount, reducing the distortion at high frequencies or low sound volume, and reproducing minimal sound data precisely.



EI type power transformer and flat-type copper coil

Large-capacity super-regulation power transformer

To high-performance EI type super-regulation transformer is placed on the power supply unit to support the high power of M-900u with the aim of eliminating the loss space, minimizing the capacity between lines, reinforcing the unifying force, stabilizing the magnetic field, and more by winding the flat-type copper coil tightly. The regulation performance that is not affected by any load fluctuation is achieved owing to the large capacity of as much as 1,250 VA. Power can be sufficiently supplied to fully drive the speaker unit.



Custom-built large-capacity block capacitor

Thoroughly low impedance transmission

To provide the power of the heavy-duty power supply circuit supplied from the large-capacity block capacitor of 20,000μF x 4 to the amplification circuit instantaneously without any loss, the main electric current line between the power supply unit and output stage is directly connected by hardwiring using an extremely thick OFC bus bar. What is more, to transmit the powerful drive force generated by the large-scale output circuit without loss, the large-capacity speaker relay with low resistance in which 4 contacts are connected in parallel is equipped. The overwhelming value of the damping factor, that is 710, has been achieved.

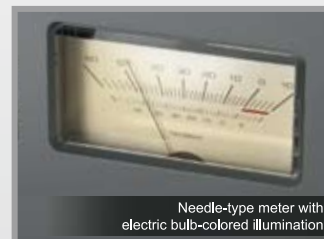

Needle-type meter with electric bulb-colored illumination

Large needle meter that shows how the sound really moves

A large-scale needle-type meter is introduced to provide not only audible sensation but also physical sensation for the lively feeling of sound. The electric bulb color of the LED illumination is the result of our persistence in dignity and visibility. The meter is equipped with the ON/OFF switch for operation and the ON/OFF switch for illumination. For M-900u, up to 12W of the output is operated with pure class A. In this case, the meter reads-10dB or so, and the inclusion of almost all of the ordinary volume range balances between high power and dense sound quality with pure class A.



Gradation cast-iron insulator leg

Highly rigid chassis structure supporting heavy parts

A stray current in the chassis generated by the ground loop may cause the deterioration of sound quality such as increase in impedance and magnetic field generation. To prevent this trouble, M-900u uses the loopless chassis that does not have a ground loop. The gradation cast-iron is used for the legs to shut off external vibrations and relieve internally generated vibrations. The chassis has a structure to hold heavy parts firmly and an appearance to show overwhelming presence and to be covered with blasted white neatly, which leads to the combination of strong and calm design.

CONTROL AMPLIFIERS

C-900u

Fully Balanced Design

New!



C-900u was newly created for the pursuit of the uppermost tone quality. The balanced amplification circuit having 4-module configuration in which the right/left and HOT/COLD of sound signals are set to be independent is introduced to suppress unnecessary noise generation. Combination of the evolved traditional ODNF circuit version 4.0 and powerful power supply unit has achieved high S/N performance sound quality without distortion. Luxman's original fixed resistance switching type attenuator, the latest version of "LECUA 1000", is used for the volume adjustment mechanism that is the major key of the control amplifier. The number of contacts is set to 88 to allow the more precise volume adjustment to be performed. This product is appropriate for calling the modern control center because of its elegant design with user-friendliness, the tone control function, premium operation feeling, and more.

SPECIFICATIONS:

- Inputs: unbalance 3 system, balance 3 system
- Outputs: unbalance 2 system, balance 2 system
- Input Sensitivity/Impedance: unbalance 255mV/43kΩ, balance 255mV/86kΩ
- Output Voltage/Impedance: unbalance rated 1V/90Ω Maximum 11V
balance rated 1V/180Ω Maximum 22.5V
- Harmonic Distortion: 0.009% (20Hz~20kHz), balance 0.005% (20Hz~20kHz)
- Frequency Response: 20Hz ~ 20kHz (+0, -0.1dB), 5Hz ~ 120kHz (+0, -3.0dB)
- Signal-to-Noise Ratio: unbalance 123dB, balance 126dB
- Power Consumption: 42W, 2.2 (at standby)
- Dimensions (W x H x D): 440×130×430mm
- Weight: 19.7kg

STEREO POWER AMPLIFIERS

M-900u

Warm, Detailed Sound

New!



The stereo power amplification, M-900u, has been created to bring out the best sound expression from the speaker system. The rich gradation sound quality has been achieved from deep bass sound to clear high tone with sufficient drive force acquired by connecting the 4-parallel push-pull structural output units in parallel. Luxman's original ODNF circuit that provides both a lively feeling and ultra-low distortion has been evolved to the latest version 4.0. The transparent large analog meter produces the enjoyment of listening to music with finesse, and the exterior design with blasted white finishing encloses high power gently. The BTL connection allows the user to use the unit as an ultra-high power monaural amplifier of 600W (8Ω).

SPECIFICATIONS:

- Inputs: unbalance 1 system, balance 1 system
- Outputs: Large-scale speaker terminal 1 system
- Continuous power output: 150W+150W(8Ω) / stereo, 300W+300W(4Ω) / stereo, 600W(8Ω) / Monaural
- Maximum power output: dumpingfactor1200W+1200W(1Ω) / stereo, 2400W(2Ω) / Monaural / 710
- Harmonic Distortion: <0.008% (1kHz/8Ω), <0.1% (20Hz~20kHz/8Ω)
- Frequency Response: 20Hz ~ 20kHz(+0, -0.1dB), 1Hz ~ 130kHz(+0, -3.0dB)
- Signal-to-Noise Ratio: 117dB
- Power Consumption: 540W, 280W (under no signal) 1.0W (at standby)
- Dimensions (W x H x D): 440×224×485mm
- Weight: 48.0kg

CONTROL AMPLIFIERS

C-700u

Electronic Tone Controls

New!



Influenced by the flexibility and supreme sonic performance of the C-600f, the C-700u control amplifier is equipped with version 4.0 of the ODNF circuit which significantly improves the distortion characteristics and overall sound quality. Fitted with the LEUCA1000 attenuator users have an accurate control whilst the RA-22 also provides quick access to tone control and input selects making it a comfortable hi-fi experience as it is a joy to hear.

SPECIFICATIONS:

- Input Sensitivity / Impedance: Unbalanced 250mV / 46k Ω
- Output / Input Impedance: Unbalanced rating 1V / 90 Ω , max, 11V
Balanced rating 1V / 600 Ω , max, 11.5V
- Frequency Response: 20Hz to 20kHz (+0, -0.1dB)
5Hz to 120kHz (+0, -0.1dB)
- Total Harmonic Distortion: Unbalanced 0.007% (20Hz to 20kHz)
Balanced 0.010% (20Hz to 20kHz)
- S/N Ratio: Unbalanced 125dB, Balanced 122dB
- Power Consumption: 28W, 2.0W (at standby)
- Dimensions (W x H x D): 440 x 130 x 430 (mm)
- Weight: 14.6kg

STEREO POWER AMPLIFIERS

M-700u

Versatile, Sweet Sound

New!



The new M-700u combines the high performance aspects of the M-600a with the latest version 4.0 of the ODNF circuit, improving distortion characteristics whilst is capable of a configuring with a wide variety of speaker systems including the use of a BLT connection. The stereo amplifier is finished with classic Luxman large needle-type analog displays as in higher-end models.

SPECIFICATIONS:

- Rated Output: 120W + 120W (8 Ω) at stereo
210W + 210W (4 Ω) at stereo
420W (8 Ω) at monaural
- Input Sensitivity: 1.1V / 120W (8 Ω)
Gain 29.0 Db
- Input Impedance: Unbalanced 51k Ω , Balanced 34k Ω
- Frequency Response: 20Hz to 20kHz (+0, -0.1dB)
1Hz to 130kHz (+0, -0.1Db)
- Total Harmonic Distortion: 0.009% or less (1kHz/8 Ω)
0.1% or less (20Hz to 20kHz/8 Ω)
- Power Consumption: 370W
110W (under no signal)
0.4W (at standby)
- Dimensions (W x H x D): 440 x 190 x 427 (mm)
- Weight: 27.5kg

PURE CLASS A...PURE MUSIC

- Class AB output devices conduct the signal through 181 -200 degree.
- Class A output devices conduct the signal through 360 degrees.

Because the transistors in a Class A amplifier are never switched off, there is obviously no crossover distortion. After all, there is no crossover – where one transistor turns off and the other supplies the load current.

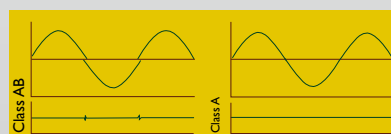

STEREO SACD/CD PLAYER

D-05

Digital Music Player



The Luxman D-05 CD/SACD player could be the last audio disc player you ever need. Built to staggering specifications, this is a pure music lover's CD player through and through. Inside this massive killer lies the heart of a lover. Check out the new Luxman proprietary transport, fully enclosed in steel to protect the laser mechanism from any EM/RFI and further isolate it from any vibration. The D-05 is equipped with both 24/96 digital inputs & 16/44 outputs.

SPECIFICATIONS:

- Compatible Formats: SACD (stereo) and CD
- Analogue Outputs: RCA x 1 pair, Balanced (XLR) x 1 pair
- Digital Outputs: Toslink x 1; SPDIF (RCA) x 1 (44.1kHz, CD player)
- Digital Inputs: Toslink x 1, SPDIF (RCA) x 1
- Dimensions (W x H x D): 440 x 133 x 410 (mm)
- Weight: 14.7kg

D-06u

Superb Quality Sound

New!



Incorporating the same high quality construction and aesthetics as the D-06, the D-06u is a luxury super audio CD player now equipped with a USB audio connection, compatible with both PC and MAC. The super audio cd player features the LxDTM, or Luxman Original Disc Transport Mechanism – our ultra-stable hardware for the most efficient of CD playback enabling you to enjoy your music at the highest quality. As the successor model to the D-06 that enabled a new-found sound for appreciators of high quality audio via CD, the updated version is set to change the game for the level of quality via USB, on your PC or Mac.

SPECIFICATIONS:

- Compatible Formats: 2 channel SACD, CD
- Analogue Outputs Voltage / Impedance: 2.5v / 300Ω (unbalanced), 600Ω (balanced)
- Coaxial digital input: 0.2 to 2.5 Vp-p
- Optical digital input: -14.5 to -21 dBm
- Dimensions (W x H x D): 440 x 133 x 410 (mm)
- Weight: 15.7kg

STEREO SACD/CD PLAYER

D-08u

Reference Quality Sound

New!



The flagship model of the CD/SACD compatible digital player, D-08u, is fully remodeled from D-08 released in 2008 and the digital and analog circuits of D-08 have been renewed. And now, our player is ready for USB connection with Windows and Mac PCs, which allows the user to reproduce file sound sources saved in PCs. LxDTM^{*1}, Luxman's original overwhelmingly rigid disk drive mechanism, is provided as a disk media player to support stable rotation system, and the latest high sound quality configuration including 32-bit digital signal processor for the digital circuit is provided to suit to the PC audio era to which we have faced for years. What is more, the latest version 4.0 of ODNF^{*2} with fully balanced configuration, which is the core of Luxman's amplifier circuit technology, is used for the analog output circuit that determines the final quality of digital equipment, and the amount of materials and latest technologies, or important 3 elements to form a digital player, "Mechanism, Digital Circuit, and Analog Circuit" that are suitable for the flagship model are integrated. D-08u provides sound expression that arouses impression unimaginable by its quantitative specification for from conventional CDs to the latest high resolution files in consideration of the future of the fast-changing sound source environment for audio systems. This product is Luxman's masterpieces that can be used and placed as the top of the lineup for a long time.

SPECIFICATIONS:

- Applicable disk: 2-channel SACD, CD
- Supported sampling frequencies: USB input (PCM): 32k, 44.1k, 48k, 88.2k, 96k, 176.4k, 192k, 352.8k, 384 kHz (16, 24, 32bits)
USB input (DSD): 2.82M, 5.64MHz (1bit)
COAX/OPT input: 32k, 44.1k, 48k, 88.2k, 96k, 176.4k, 192 kHz (16, 20, 24bits)
- Analog output voltage/impedance: 2.5V/300Ω (unbalanced), 600Ω (balanced)
- Frequency response: CD 5Hz to 20 kHz (+0, -0.5dB)
CD 5Hz to 50 kHz (+0, -3.0dB)
USB 2Hz to 50 kHz (+0, -3.0dB)
- Total harmonic distortion: CD 0.0015%, SACD 0.0011%, USB 123dB
- S/N ratio (IHF-A): CD 123dB, SACD 106dB, USB 123dB
- Disk drive mechanism: LxDTM (with dust-proof shutter)
- D/A converter: Burr-Brown-made PCM1792A (monaural mode) x 2
- Output amplifier circuit: Fully balanced discrete ODNF version 4.0
- Power consumption: 36W, 1W (at standby)
- Dimensions (W x H x D): 440x154x 413mm
- Weight: 22.5kg



Digital circuit

The USB input is ready for up to 384 kHz/32-bit PCM data and DSD data (2.8M, 5.64MHz).

The S/PDIF input is ready for up to 192 kHz/24-bit PCM signals.

TAS3152, the latest 32-bit digital signal processor manufactured by Texas Instruments Incorporated, is introduced to up sample PCM signals to up to 384 kHz.

For PCM signals, 3 types of sound qualities are switchable by the DAC chip-embedded analog FIR filter.

The low phase noise clock module with high precision and low jitter is equipped to reduce noise near the oscillating frequency.

The jitter of USB signals is reduced by the dedicated DSP via asynchronous communication, the jitter of CD or S/PDIF signals is reduced by the embedded DAIR high-precision clock, and the jitter of SACD signals is reduced by the dedicated jitter reduction chip.

Dual-configured (monaural mode) PCM1792A manufactured by Texas Instrument Incorporated is used for the DA converter, which has achieved ultra-high S/N ratio and dynamic range (theoretical value: 132dB).

DIGITAL AUDIO

DA-100

Digital to Analogue Converter



The DA-100 is a new DAC developed by Luxman, particularly because of the growing demand for DACs in an increasingly expanding digital market. It allows the consumer to enjoy music stored in digital sources on his Hi-Fi system. DA-100 designed can easily play the music files to support 96kHz/24bit high quality USB in addition to 192kHz/24bit optical/coaxial outputs. Which are stored on your computer after downloading HD tracks or ripping CDs and achieve the impeccable sound performance that audiophiles require.

It is compliant to USB 1.1 and 2.0. It can output in various formats like: COAX, OPT and RCA Phono. In addition to the DA-100 can be used in two different applications: as a DAC and as a USB Interface.

SPECIFICATIONS:

- Sampling Frequency: COAX/ OPT inputs: 32kHz, 44.1kHz, 48kHz, 88.2kHz, 96kHz, 176.4kHz, 192 kHz
USB input: 32kHz, 44.1kHz, 48kHz, 96kHz
- Digital Inputs: USB(B type), OPT, COAX Digital Outputs: COAX, OPT
- Analog Outputs: RCA unbalance x 1, Headphone x 1
- Line Outputs Voltage/ Impedance: 2.1V/300Ω
- Headphone Outputs: 1.30Mw+1.30Mw(600Ω), 80Mw+80Mw(32Ω),
- Frequency response: 2Hz ~60kHz (+0, -3dB)
- Total Harmonic Distortion: 0.004%
- Dimensions (W x H x D): 149 x 70 x 232 (mm) • weight: 2.3kg

DA-200

Digital to Analogue Converter



The Luxman DA-200 is a state-of-the-art digital audio product and versatile control centre featuring a superlative 24-bit/192kHz DAC with two line level analogue inputs, two S/PDIF digital inputs plus a dedicated 24-bit/96kHz USB input to support PC and Mac.

The DA-200 incorporates a Burr-Brown PCM1792A DAC and adopts asynchronous data processing using a sample rate converter, an effective means of eliminating clock jitter inherent of digital source components and computers. The Class A differential audio outputs stage then feeds a pre-amplifier of low source impedance, with user-switchable fixed / variable XLR balanced and RCA unbalanced outputs. A headphone amplifier of the highest caliber for driving a wide variety of headphones is built in. All peripheral circuits of the DAC and the analogue output stage well compares to the famed D-05 SACD/CD Player in terms of sonic virtues. Luxman's typical round-pattern printed circuit boards, spiral-wrap shielded internal wiring and custom parts further enhance the sonic performance of the DA-200. The front panel display screen has 7-segment LED indicator that monitors all input and output sampling frequencies in real time.

The Luxman DA-200 possesses a warm yet tonally correct reproduced sound, with ability to retrieve every detail captured in music recordings. The message of a live musical performance is conveyed in such an easy manner that the listener immerses in the music being reproduced.

SPECIFICATIONS:

- SPECIFICATIONS:
- General Description: 2-channel digital-to-analogue converter
- Sampling Frequency: Digital inputs: 32kHz, 44.1kHz, 48kHz, 88.2kHz, 96kHz, 176.4kHz, 192kHz
USB input: 32kHz, 44.1kHz, 48kHz, 96kHz
- Resolution: 24 bits
- Digital Inputs: 1 x Coaxial; 1 x Toslink optical ; USB (B type)
- Digital Outputs: 1 x Coaxial; 1 x Toslink optical
- Analogue Inputs: 2 x RCA line level
- Output level: Digital input: 2.5V (fixed); 8.7V Max. (variable)
- Frequency Response: Digital input: 2Hz – 60kHz (+0, -3dB)
Analogue input: 3Hz – 130kHz (+0, -3dB)
- S/N Ratio: Digital Input: 119dB Analogue Input: 103dB
- Dimensions (W x H x D): 364 x 81 x 279 (mm) • Weight: 5.1kg

DIGITAL AUDIO

DA-06

Digital to Analogue Converter



DSD
Direct Stream Digital

LUXMAN have launched the best remarkable DSD digital audio and USB input DA - 06 D/A converter.

This latest perfect design DAC component will remain elusive to those seeking perfection where it can't be found. Every component regardless of price or prowess of the designer has a sonic signature. DA-06 DAC reproduces music with a rich tonal balance and silky smooth midrange, yet a satiating amount of transparency. It's capable to reproduce both PCM and DSD with its lush signature Luxman sound. And enables all listener to get lost in the music rather than the format.

DA - 06 product platform incorporate the large-scale analog circuit, also corresponding to regenerate the USB input up to 384 KHZ / 32 bits PCM data and 5.64 MHz DSD data of digital circuit, belongs to A high level of D/A converters. This super high performance converter can fully meet the latest market demand, with excellent usability and reliability, and its unique timbre audio enthusiasts can definitely make you fully enjoy the PC & MAC music unlimited fun.

SPECIFICATIONS:

- Form: 2 channel D/A converters
- Appropriate sampling frequency: USB input(PCM): 32k, 44.1k, 48k, 88.2k, 96k, 176.4k, 192k, 352.8k, 384kHz (16, 24, 32bit)
USB input(DSD): 2.82M, 5.64MHz
COAX/OPT/AES/EBU input: 32k, 44.1k, 48k, 88.2k, 96k, 176.4k, 192kHz (16,20,24bit)
- Digital input: USB(Type B) 1 system, COAX 2 system, OPT 2 system, AES/EBU(XLR) 1 system
- Digital output: COAX system, OPT 1 system
- Analog output: RCA unbalanced system, XLR balanced 1 system
- Cable output voltage /impedance: 2.5 v / 300 Ω (imbalances) and 600 Ω (balance)
- Overall dimensions, weight: 440 (W) x 92 (H) x 400 mm (D) 11.0 kg (product net weight)

STEREO POWER AMPLIFIERS

M-200

Stereo Power Amplifier



Luxman has always pioneered and influenced the Hi-Fi industry. Luxman amplifiers are known the world over for their sound quality, functionality and elegant aesthetics. To this the M-200 adds to an already successful and influential M series of amplifiers. Although small and compact in size, the M-200 offers exceptional performance one would expect from a Luxman amplifier.

The M-200 stereo amplifier offers Class AB amplification, thus issues like crossover distortion are long forgotten allowing the listener to listen to virtually noiseless amplification. It also offers choice of inputs in balanced and unbalanced form.

SPECIFICATIONS:

- Succession effective output: (Normal) - 25W + 25W (8Ω) (BTL) - 70W (8Ω)
- Total harmonic distortion: 0.005% (8Ω, 1 kHz, Both CH simultaneous drive)
0.06% (8Ω, 20~20 kHz, Both CH simultaneous drive (-3dB))
- Amplification: STEREO - 23dB BTL - 29dB
- S / N Ratio: LINE - 107dB or over BALANCE LINE - 102dB or over
- Frequency characteristics: 20Hz ~ 20,000Hz (-0.2dB)
- Damping factor: 100
- Power Consumption: 80 W (According to the Electrical Appliance and Material Safety Law) 30 W (No input)
- Dimension (W x H x D): 440 x 224 x 485(mm)
- Weight: 7.0kg

PHONO AMPLIFIER

E-200

Solid-State Phone Stage



Luxman's latest compact phono stage, is full of useful features and superb sound quality. Built-in switchable gain control, the MC step up transformer uses a super permalloy core to cope with low impedance cartridges. E-200 has a cartridge demagnetizer switch (articulate) which demagnetizes the cartridge from the convenience of the front panel. Beautiful aluminum front panel similar to what is found on Luxman's high-end series. The E-200 phono stage is remarkably musical & yet resolute.

SPECIFICATIONS:

- Input Sensitivity: MM: 4mV, MC High: 0.4mV, MC Low: 0.18mV
- Inputs: Impedance: MM: 47kΩ, MC High: 40Ω, MC Low: 2.5Ω
- Gain: MM: 36dB, MC High: 56dB, MC Low: 63dB
- Output Voltage: 250mV (1 kHz)
- Output Impedance: 300Ω
- Power Consumption: 4W
- Dimensions (W x H x D): 364 x 84 x 257 (mm)
- Weight: 4.4 kg

HEADPHONE AMPLIFIERS

P-700u

Luxman's Finest Headphone Amplifier



The P-700u headphone amplifier is a remarkable flagship pure Class A Headphone Amplifier, with new design of ODNF 3.0A delivers the fully balance state-of-the-art musical performance for the perfect matching of Low impedance up to high impedance headphone lover. Luxman's emphasis is on reproducing natural music, with lots of warmth and detail... Luxman's engineers' are fanatical in their attention to the musical detail; while they spend a lot of time analyzing how components perform on their test equipment, the final arbiter is the listening evaluations. In the product able to convey the music with a lot of heart and soul, reproduce the ambience of the venue as well as the timbre of each instrument, distinctly. This is where Luxman shines.

SPECIFICATIONS:

- SPECIFICATIONS:
- Continuous power output: Unbalance 4W + 4W(8Ω), 2W + 2W(16Ω), 1W + 1W(32Ω) / 53mW + 53mW(600Ω) Balance 8W+ 8W(16Ω), 4W + 4W(32Ω) / 213mW + 213mW(600Ω)
- Input sensitivity/input impedance: Unbalance: 1.0 V/15 kΩ, balance: 2.0 V/40 kΩ
- Total harmonic distortion rate: 0.0035% (1 kHz), 0.002% (1 kHz)
- Frequency response: 20 Hz–20 kHz (+0, -0.1 dB), 5 Hz–170 kHz (+0, -3.0 dB)
- Signal-to-Noise Ratio: Unbalance 110dB, Balance 115dB
- Input: 1 x RCA unbalanced line & 2 x XLR balanced line
- Output: 2 x 6.35mm standard phone jack & 2 x XLR balanced output
- Control & Functions: Front: power switch, +/-volume, input & sensitivity selection, output mode and through output ON/OFF
- Power Consumption: 42W
- Dimensions (WxHxD) and weight: 440 x 92 x 400 mm & 12.7kg

P-200

Headphone Amplifier



Compact high quality, pure A class amplifier, delivers 2 watts per channel into 8Ω. Parallel Push-Pull structure. Connect a CD player and /or iPod to the P-200 and enjoy listening to music in a 2 input switchable system. CD player's output can be pass through the P-200's output to another pre-amplifier. P-200 is equipped with both a stereo mini plug socket and a 1/4" high quality headphone socket.

SPECIFICATIONS:

- Rated Output: 2W+2W/8Ω and 1W+1W/16Ω
- Inputs: Unbalanced RCA x 2 pair
- Outputs: 6.35mm standard headphone jack x 1, 3.5mm mini headphone jack x 1
- Input Sensitivity/Impedance: 1V / 47kΩ
- Harmonic Distortion: 0.015% or less (1kHz)
- Frequency Response: 10Hz ~ 100kHz (+0, -3.0dB)
- Signal-to-Noise Ratio: 100dB
- Power Consumption: 1.6W
- Dimensions (W x H x D): 364 x 84 x 257 (mm)
- Weight: 4.4 kg

The STAR Circuit: Fine definition for music

Inside an amplifier, music signals travel from the input toward the output. Along the way, the signals' current level increases and fluctuates in response to dynamic changes in the music. This means currents of varying strengths are flowing over circuit boards.

If they are allowed to flow randomly, they can interfere with each other, robbing music of its naturalness and realism. To solve this problem, Luxman engineers have isolated and streamlined current flows of varying strengths inside the amplifier. Routing each

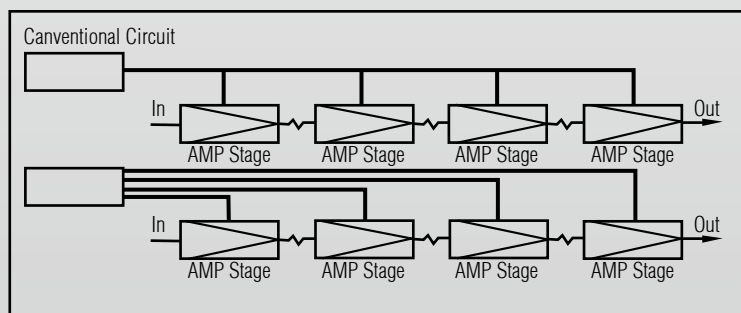

current flow individually prevents currents on different layers from interfering with each other. Also, with the point of reference for each amplifier clearly defined, the STAR Circuit makes music so real its almost tangible.

CLASSIC INTEGRATED AMPLIFIER

L-305

Solid State Integrated Amplifier



The L-305 is an integrated amplifier that brings back the smooth soft sounds of the analogue era. Designed using Luxman's ODB circuit, originally introduced back in 1980 and remained at the heart of Luxman designs for almost 20 years. With features including an authentic phono stage amplifier compatible with both MM/MC cartridges and natural wood veneer finished casing, the L-305 provides a truly nostalgic experience that is nearly lost in today's market.

Other features of the L-305 include a 300V customized power supply transformer, 3 stage tone control function, and wide gold plated speaker terminals all adding to the quality and flexibility of the L-305. Thoughtful industrial and mechanical design married with classic high-end electronics make the L-305 a modern day tribute to the craftsmanship and details of the past.



Exclusive Design Patent By Luxman

*ODB: Optimized Dual Beta

*CSSC: Complementary Single Stagger Circuit

SPECIFICATIONS:

- Continuous Rated Output: 50W+50W (8Ω); 75W+75W (8Ω)
- Total Harmonic Distortion: 0.005%(8Ω,1kHz, stereo, tone defeat on); 0.04%(8Ω, 20~20kHz, stereo(3dB), tone defeat on)
- S/N Ratio: PHONE(MM): > 85dB; PHONO(MC): > 69dB; CD/LINE: > 100dB(A-Weighting, Input short, tone defeat on)
- Frequency Response: PHONE(MM): 20Hz!20kHz(±0.5dB, tone defeat on); PHONO(MC): 20Hz!20kHz(±0.5dB, tone defeat on); CD/LINE: 20Hz!20kHz(±0.5dB, tone defeat on)
- Dimensions (W x H x D): 400 x 169 x 330(mm)
- Net Weight: 15kg

INTEGRATED AMPLIFIERS

L-505uX

A Taste of Luxman



LUXMAN have launched the latest generation of transistor integrated amplifier, the 3rd version of the highly rated X series, L-505uX, with a high output power of 100W(8Ω) 150W(4Ω). This high performance amplifier introduces Luxman's electronically controlled attenuator LECUA.

Over the last 15 years, since L-505s was first introduced in 1996, it has experienced three times model changes. Now the L-505uX, as the latest full revision model of luxman 500 series, is avidly expected and popularly supported by audiophiles all over the world.

With an illuminated central oriented VU meter on its solid, symmetrical facia, L-505uX introduces a high accuracy electronically controlled attenuator LECUA and Luxman exclusive high sound quality feedback circuit ODNF high S/N version 2.3, while keeping all the other superb features of Luxman products made in Japan.

SPECIFICATIONS:

- Continuous Outputs: 100W+100W(8Ω), 150W+150W(4Ω)
- Input: line x 4, phono x 1(MM/MC) balance: line x 1, recording input/output x 1, separate inputs x 1
- Loudspeaker Output: A,B System (A+B output)
- Amplifying Circuit Output: ODNF2.3
- Input Sensitivity / Impedance: Phono (MM): 2.5mV / 47kΩ, PHONO (MC): 0.3mV / 100Ω, LINE: 180mV / 47kΩ
- Harmonic Distortion: 0.005% or less (1KHz / 8Ω)
0.04% or less(20Hz ~ 20KHz / 8Ω)
- Frequency response: 20Hz ~ 100KHz(+0, -3.0dB)
- Signal-to-Noise: PHONO(MM):>91db, PHONO(MC):>75db, LINE:>105dB
- Power Consumption: 270W(rated output), 85W(no signal), 0.4W(idle)
- Dimensions (W x H x D): 440 × 178 × 454 (mm)
- Net Weight: 22Kg

L-507uX

Powerfull Musician



Luxman is pleased to announce the L-507uX this merger of transistor amplifier, the 4th version of the highly rated X series, with a high output power of 110W(8Ω) 220W(4Ω). The L-507uX integrated amplifier introduces Luxman electronically control attenuator LECUA, with an illuminated central oriented VU meter on its solid, symmetrical facia, also includes the Luxman exclusive super sound quality feedback circuit ODNF high S/N version 3.0, while keeping all the superb features of Luxman products made in Japan.

The first L-507-s introduced in 1996, since 16 years, has experienced three times the model after the change, L-507uX as Luxman's new model, with great sales by many users support, belonging to L-500 series full of the latest change model.

SPECIFICATIONS:

- Continuous Outputs: 110W+110W(8Ω), 210W+210W(4Ω)
- Input: line x 4, phono x 1(MM/MC) balance: line x 2, recording input/output x 1, separate inputs x 1
- Loudspeaker Output: A,B System (A+B output)
- Amplifying Circuit Output: ODNF3.0
- Input Sensitivity / Impedance: Phono (MM): 2.5mV / 47kΩ, PHONO (MC): 0.3mV / 100Ω, LINE: 180mV / 47kΩ
MAIN-IN:1.05V/47kΩ
- Harmonic Distortion: 0.005% or less (1KHz / 8Ω)
0.04% or less(20Hz ~ 20KHz / 8Ω)
- Frequency response: 20Hz ~ 100KHz(+0, -3.0dB)
- Signal-to-Noise: PHONO(MM):>91db, PHONO(MC):>75db, LINE:>105dB
- Power Consumption: 300W(rated output), 86W(no signal), 0.4W(idle)
- Dimensions (W x H x D): 440 × 177 × 454 (mm)
- Net Weight: 23.9Kg

INTEGRATED AMPLIFIERS

L-550AX

Pure A

Sophisticated, Liquid MidRange



The L-550AX is a solid-state integrated amplifier to incorporate a truly lossless volume control and superior audio circuitry. With an illuminated central oriented VU meter in its solid, symmetrical front fascia, the L-550AX incorporates the LECUA 1000 high precision electronically controlled attenuator, the latest ODNF 3.0A audio circuit and custom passive components as used in Luxman's flagship C-1000f control amplifier and B-1000f mono power amplifier.

The LECUA 1000 attenuator is configured to electrically block electromagnetic (EMI) and radio frequency (RFI) interferences. The output signal is attenuated without introducing artifacts inherent of conventional volume controls, thereby resulting in constant output impedance, high signal-to-noise ratio, a uniform frequency response and lowered distortion. As its name implies the ODNF (Only Distortion Negative Feedback) only applies negative feedback where distortion is present to reduce colouration more effectively.

This lossless audio circuit enables the amplifier to retrieve every musical nuance captured by recording engineers. Transient response, attack, dynamic contrast, timbre, inner detail, and bass authority are preserved.

SPECIFICATIONS:

- Rated Output: 2 x 20W RMS / 8Ω 2 x 40W RMS / 4Ω
- Input Sensitivity / Impedance: Phono (MM): 2.5mV / 47kΩ
Phono (MC): 0.3mV / 100kΩ
Line: 180mV / 42kΩ
- Total Harmonic Distortion: <0.007%
- Frequency Response: 20Hz ~ 100kHz (-3dB)
- S/N Ratio: >105dB
- Line Inputs: 4 x LINE, 1 x Balanced, 1 x MM/MC (switchable),
1 x TAPE, 1 x Power Amp in
- Line Outputs: 1 x Pre-Amp out, 1 x TAPE, 1 x headphones
- Speaker Outputs: Speaker A/ B switchable, Speaker A+B
- Dimensions (W x H x D): 440 x 178 x 454 (mm)
(including control knobs and terminals)
- Weight: 24.3 kg

L-590AX

Pure A

Sophisticated, Liquid MidRange



The L-590AX is another model in Luxman's X-Series pure Class A solid-state integrated amplifiers to stun the high end market. It is a state-of-the-art integrated amplifier featuring the weight matrix LECUA 1000 attenuator, excellent engineering, extreme rigidity, elaborate circuit design and layout for the shortest signal path. These elements are only peculiar to the most exotic separate pre-amplifiers and power amplifiers. In addition, it possesses penetrating ability and a beguiling sound only inherent of pure Class A operation.

The heavily regulated power supply comprises an oversized power transformer and an ample 40,000μF filtering capacitor array. Notwithstanding its 2 x 30W modest power rating, the L-590AX is capable of driving virtually any speaker load.

SPECIFICATIONS:

- Rated Output: 2 x 30W RMS / 8Ω, 2 x 60W RMS / 4Ω
- Input sensitivity / Impedance: Phono(MM): 2.5mV / 47kΩ
Phono(MC): 0.3mV / 100kΩ
Line: 180mV / 42kΩ
- Total Harmonic Distortion: <0.005%
- Frequency Response: 20Hz ~ 100kHz(-3dB)
- S/N Ratio: 107dB
- Line Output: 4 x LINE, 2 x Balance, 1 x MM/MC(switchable),
1 x TAPE, 1 x Power Amp in
- Line Output: 1 x Pre-Amp out, 1 x TAPE, 1 x headphones
- Speaker Outputs: Speaker A/B switchable, Speaker A+B
- Dimensions (W x H x D): 440x 193 x 463 (mm)
(Including control knobs and terminals)
- Weight: 28.2kg

ANALOGUE TURNTABLE

PD-171AL

Belt-Drive Turntables

New!



■ PD-171AL-specific arm base

- 20-mm-thick brazen chromeplated, spin finish



For SME 3009R/3010R and other 9inch, 10inch tonearms
OPPD-AB1



For FR 64/64S/64FX IKEDA IT-345
OPPD-AB2



For SAEC WE-308
OPPD-AB3



For SAEC WE-407/23
OPPD-AB4



For ORTOFON 212S/212D
OPPD-AB5



DIY universal tonearm board
OPPD-AB6

Since the introduction to PD-171 into the market in 2011, which has been highly admired as an analog player that delivers the temperature sense and atmosphere sense of sound put into a phonograph record, and now the longed-for armless type has arrived, Highly evaluated physical characteristics of PD-171 such as high-rigid main chassis and heavy turntable securing stable rotation are inherited, and the mechanisms of the motor, drive circuit, and bearing section have been improved for further accuracy. PD-171AL is an analog player, and an audio component that the user can customize to allow for enjoying sound change. Setting PD-171AL to an armless type allows the user to appreciate analog reproduction more deeply. This sentence is written to express the image of letter entry and has nothing to do with the contents of the catalog.

Features

Electric circuit

- Introduction of newly developed high-torque AC motor
- AC synchronous motor drive with use of the circuit of high power audio amplifier structure
- High-precision clock controlled generator circuit with 32-bit microprocessor embedded
- Reflective view type LED stroboscope useful for adjusting the rotation speed in a precise manner equipped

Mechanism

- Belt drive type aluminum machining heavy turntable (5.0kg) utilizing high inertia moment (approx. 0.7t.2)
- Main parts underslung (hanging) vibration-damping structure with the main chassis of 15-mm-thick machined aluminum plate
- High-rigid 16mm spindle with ball bearing to support stable rotation
- Wear-resistant and load-bearing polyether ether ketone (PEEK) material used in the bearing section
- Floating mounted power transformer and AC motor
- Hybrid vibration-damping structure with wood and metal
- Large-sized insulator with height adjustment function directly secured to aluminum chassis

Exterior

- Traditional wood-paneled design
- AC inlet on the rear panel to allow for replacement of power cable
- Detachable high-intensity LED type stylus light useful for playback of a phonograph record in a dark listening room supplied
- Cam support type 4-mm-thick acrylic dust cover openable and closable by light operation supplied

SPECIFICATIONS:

- Drive system: Belt drive system
- Motor: Reaction and AC synchronous motor
- Platter: 30cm machined aluminum plate (weight 5.0 kg)
- Revolution: 33 1/3 rpm, 45 rpm (2 speeds selectable)
- Revolution adjustment range: $\pm 5\%$ (each rotation speed adjustable independently)
- Wow and flutter: 0.04% or less (W.R.M.S)
- Power source: 230 V ~ (50 Hz)
- Power consumption: 38 W
- Dimensions (W x H x D): 492 x 140 (up to top face of platter), 195 (with dust cover mounted) x 407 (10 mm of fittings on rear face included)mm
- Weight: 23.8 kg

New!

PD-171A



PD-171A Turntable set with Jelco tonearm included

CLASSIC VACUUM TUBE AMPLIFIERS

CL-38u

Valve Pre Amplifier



Housed in an appealing wooden cabinet the CL-38u employs 3 x ECC83 and 5 x ECC82 in classic SRPP (Shunt Regulated Push Pull) configuration throughout all gain stages for extremely low output impedance thereby achieving strong drivability to cope with the most awkward amplifier loads. The use of four moving-coil step-up transformers in the phono stage further enables quiet and accurate reproduction of music recorded onto the LP. The CL-38u is a full-function pre-amplifier built to fulfill Luxman's design philosophy in quest of functions and sound quality peculiar to modern valve amplifiers.

SPECIFICATIONS:

- Input Sensitivity / Impedance: LINE: 190mV / 50k Ω , PHONO (MM): 2mV / 47k Ω , PHONO (MC-H): 0.3mV / 100 Ω , PHONO (MC-L): 0.08mV / 30 Ω
- Output Voltage / Impedance: 1V RMS / 300 Ω , 19V (max.)
- THD: 0.006% (1kHz), 0.06% (20Hz - 20kHz)
- Frequency Response: PHONO: 20Hz - 20kHz (+0, -0.5dB), LINE: 10Hz - 70kHz (+0, -3.0dB)
- S/N Ratio: LINE: 100dB, PHONO (MM): 68dB, PHONO (MC-H): 63dB, PHONO (MC-L): 60dB
- Input: LINE x 4, PHONO x 1
- Tape Input / Output: 1 set
- Line Output: 2 sets
- Tone Control: Bass Turnover Frequency: 150Hz / 300Hz / 600Hz
Treble Turnover Frequency: 1.5kHz / 3kHz / 6kHz
- Low cut: 30Hz (-6dB/oct)
- Dimensions (W x H x D): 400 x 170 x 307 (mm)
- Net Weight: 13.5kg

MQ-88u

Valve Power Amplifier



The MQ-88u is based upon the MQ-60 stereo power amplifier, still sought-after to date. It utilizes KT-88 power tubes by Slovakia JJ in triode mode. OY-type output transformers encased in cast aluminium housing provide low output impedance for ideal speaker interface. This unit is equipped with one each of fixed and variable inputs, the latter enabling direct connection with any source component without a pre-amplifier. Delivering 2 x 25W into 6 ohms it operates in pure Class A adopting Luxman's long renowned vacuum tube circuit design. Tube complement comprises 2 x ECC83, 2 x ECC82 and 4 x KT88.

SPECIFICATIONS:

- Rated Power Output: 25W + 25W (6 Ω), 20W + 20W (4 Ω , 8 Ω)
- Input Sensitivity: 790mV / 25 W (6 Ω)
- Input Impedance: 100k Ω
- THD: 0.15% (1kHz / 6 Ω / 1W), 0.5% (20Hz ~ 20kHz / 6 Ω / 1W)
- S/N Ratio (IHF-A): 105dB
- Input: 1 x Direct, 1 x Variable
- Output: Large speaker terminal x 1 set
- Dimensions (W x H x D): 440 x 185 x 230 (mm)
- Net Weight: 15.8kg

AUDIO CABLE

Reference Series

The Reference Cable JP Series is a new genuine set of cables with the conductor into which high-purity oxygen-free copper (OFC) is integrated to strongly support the environment of connecting high-quality audio systems. We have conducted sound quality tuning in a thorough manner with Luxman's know-how and technologies accumulated for many years in development of audio amplifiers.



JPR-100

Features High-purity oxygen-free copper (OFC) conductor
Length 1.0 m, pin cord type

JPR-150

Features High-purity oxygen-free copper (OFC) conductor
Length 1.5 m, pin cord type



JPC-100

Features High-purity oxygen-free copper (OFC) conductor
Length 1.0 m, XLR cable type

JPC-150

Features High-purity oxygen-free copper (OFC) conductor
Length 1.5 m, XLR cable type



JPU-150

Features High-purity oxygen-free copper (OFC) conductor
Length 1.5 m, USB cable type



JPA-15000

Features High-purity oxygen-free copper (OFC) conductor
Length 1.8 m, reference power cable

Rca Shorting Plug Set

By mounting an RCA shorting plug on an open RCA input terminal and preventing noise mixture and mechanical vibrations, the audio unit provides stabilized operation and clean smooth signal transmission.



JPT-10

Solid brass carved, 24 gold plating
Shorting plug: 28.5 x 12mm (length x diameter), 12.5 g/piece, 160 g/set (8 pieces, box included)

Excerpts from Reviews & Recent Awards

D-08u

"D-08u was a noticeable sonic improvement over the DA-06, noticeably more resolute."

D-08u won another Oasis award from Positive Feedback for Best Sound at the Show from the editor David Robinson.

David Robinson (USA)

The superbly finished machine builds on all the sonic strengths of the previous D-08 model but goes to new levels of sonic excellence thanks to all-new digital and analog circuits. Stereo NET (Australia)

PD-171 and D-08u

"Baritone Matthias Goerne's voice sounded very warm and simply gorgeous, as did a cut from Illinois Jacquet's fabulous Birthday Party LP. Images were huge and deep, with surprisingly profound bass."

Jason Victor Serinus <<http://www.stereophile.com/writer/119>> , [Stereophile, \(USA\)](#)

L-507uX

Best Buy, Audiogram, (Czech) 2013

Amplifier of the Year 2013, 2nd Place, [Hi-Fi Voice\(Czech\)](#)

L-590AX

Excellent, World of Audio, [\(Czech\) 2014](#)

DA-06

"It is like a music instrument feeding a listener's ear with what they love: shimmering highs, ponderous lows, supersweet mids, spacious soundstage with ample details and expanding dynamics... one of the finest SACD/CD players today."

- Recipient, 100% Reference Award. [Martin Justan, Audiodrom \(CZ\), May 2010](#)

PFO Brutus Award, 2013

Positive Feedback Online, December 1, 2013 A.D. Dr. [David W. Robinson \(USA\)](#)

"The Luxman DA-06 DAC reproduces music with a rich tonal balance and silky smooth midrange, yet a satiating amount of transparency. The DA-06 is unique among DACs I've heard in recent memory because of those qualities. This is a DAC for listening to and being enveloped by one's favorite music."

[Chris Connacker, Editor Computer Audiophile - winner of CASH Award June 2013](#)

"The music made by the Luxman DA-06 is rich, resolute, refined, and oh so smooth. Regardless of my music's pedigree, I found myself enjoying entire album's worth upon album's worth, getting sucked into their sounds and moods to the point of being completely lost in tunes. I cannot think of a higher compliment to pay a piece of hi-fi gear."

Michael Lavorgna <<http://www.audiostream.com/writer/27619>> Editor

[Audiostream - winner of Greatest Bits Award June 2013](#)

M-900u & C-900u

C-900u had been named 2014 Product of the Year — Outstanding Performance.

[USA, 2014, SoundStage! Hi-Fi and SoundStage! Ultra.](#)

The M-900u and the C-900u get our 100% Reference award and I am sorry that Audiodrom does not grant anything like 150% Reference, for example. They are that good.

-Mr. Justan from Audiodrom, Czech, 2014

P-700u

匠心獨運的全平衡電路編排，讓每個部份均加倍份量地悉心炮製的LUXMAN P-700u，像部純音響放大器多於似部耳擴，不過電路繁多使全機佈線看似有點複雜，但原來這是特為遷就左右分明電路再儘量縮短訊號通道的設計，因而精密繁複卻顯得經緯分明，且所用全屬經適度屏蔽的高純度無氧銅線，能因此儘減電誘率及電容量，帶來無損音樂訊號更不會產生音染確保傳真的重播效果。在電源部份適量加入磁環，配合全平衡LECUA+ODNF 3.0A+CLASS A等多重杜絕訊噪干擾和確保靚聲的精妙電路處理手法，對輸入的音樂訊號帶來最低和最少電子以及人工化影響，讓P-700u具備LUXMAN耳擴中前所未有的地平直自然的寬闊頻應，低失真地發放出最能貼近原訊號並無明顯個性的音效。

[鐘啟源，音響技術 \(HK\)](#)



LUXMAN

IAG House, 13/14 Glebe Road, Huntingdon, Cambridgeshire, PE29 7DL, UK
Tel: +44 (0)1480 452561 Fax: +44 (0)1480 413403 <http://www.luxman.com>

ラックスマン株式会社 〒222-0033 神奈川県横浜市港北区新横浜1-3-1
tel.045-470-6991 fax.045-470-6997 www.luxman.co.jp

IAG reserves the right to alter the design and specifications without notice. All rights reserved © IAG Group Ltd.
Luxman is a member of the International Audio Group. CODE: LN12-BR0001

