

SERVICE MANUAL

Stereo Integrated Amplifier

LV-112

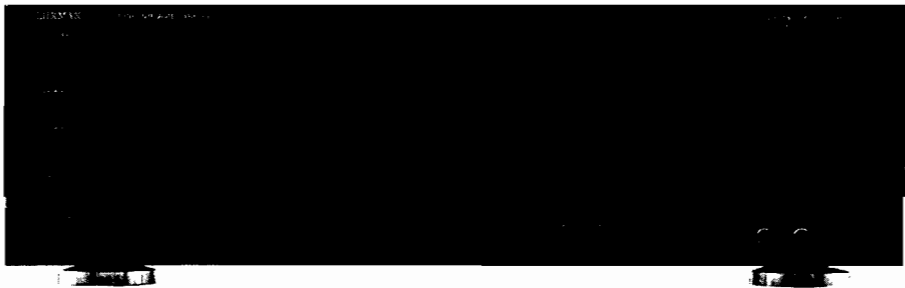

Contents

Specifications	2
Parts Locations and Disassembly Instructions	3 to 4
Adjustment Procedures	5
Adjustment Locations	5
Block Diagram	6
Schematic Diagram	7 to 10
Parts Layout on P.C. Board & Wiring Diagram	11 to 14
Electrical Parts List	15 to 18
Packing Method View	19
Packing Assembly Parts List	19
Cabinet Assembly Parts List	20
Exploded View (Cabinet)	21 to 22
Semi-Conductor Lead Identifications	23 to 25

Specifications

VLV112AD/UQ/UZ

Power-Output	55W(0.1% THD 20Hz ~ 20kHz)
Headphones Output	55W(80ohms~1kHz)700mV±10%
Input Sensitivity(1kHz)	CD, Tuner, DAT/Tape-1:150mV±15% DAT/Tape-2, AUX(L-ch, Mono):150mV±15% Phono(MM):2.5mV±20%
Input Impedance(1kHz)	CD, Tuner, DAT/Tape-1:40kohm±15% DAT/Tape-2, AUX:40kohm±15% Phono(MM):47kohm±15%
Frequency Response	DAT/Tape-1, DAT/Tape-2:(10Hz~100kHz)+1, -4dB CD, Tuner, AUX:(10Hz~100kHz)+0.6, -3dB Phono(MM):(100Hz)13.09±1dB Phono(MM):(10kHz)-13.74±1dB
Loudness Control(VR-30dB)	(100Hz)6±2dB (10kHz)4±2dB
Tone Controls	Bass:(100Hz)±10±3dB Treble:(10kHz)±10±3dB
S/N Ratio	CD, Tuner, AUX:32.9dB
(Input Terminal Shorted)	DAT/Tape-1, DAT/Tape-2:78.5dB Phono(MM):34.9dB
Crass Talk(10kHz)	CD, Tuner, DAT/Tape-1:40dB Phono(MM):30dB
Residual Noise	1.2mV
Power Supply	120/220/240V, 50Hz
Semiconductors	10IC's, 19Transistors, 37Diodes, 4Zener Diodes
Dimensions	438(W) × 137(H) × 365(D)mm
Weight	9kg

Note:Due to continuing product improvement, specifications and design are subject to change without notice.

Parts Locations and Disassembly Instructions

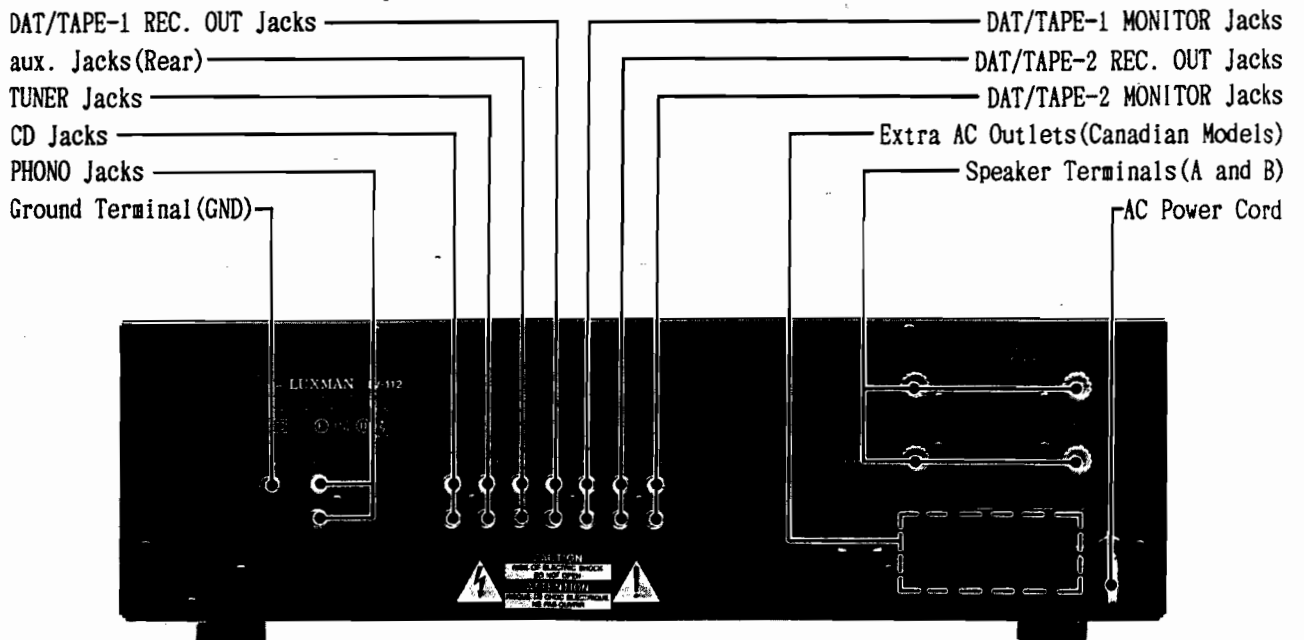
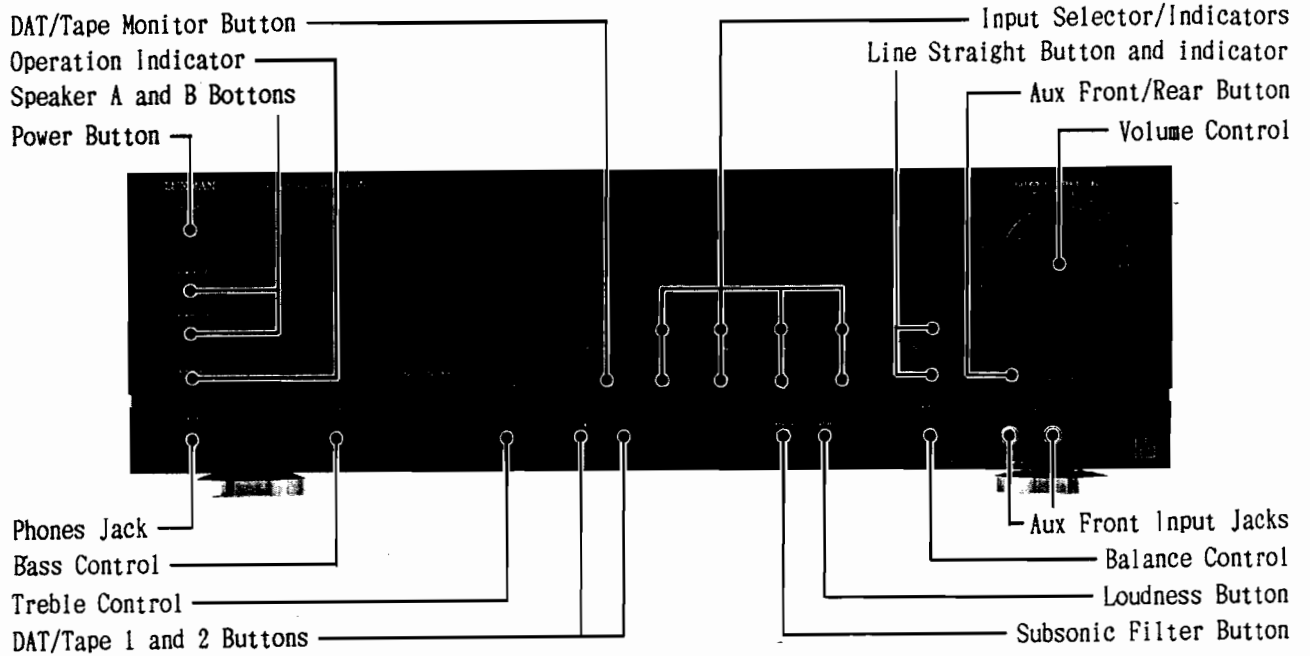

1. Removal of Top Cover

- (1) Remove six screws marked "○" as shown in Figure 3 and 4.
- (2) Pull out the Top cover in the direction of the arrow as shown in Figure 3.

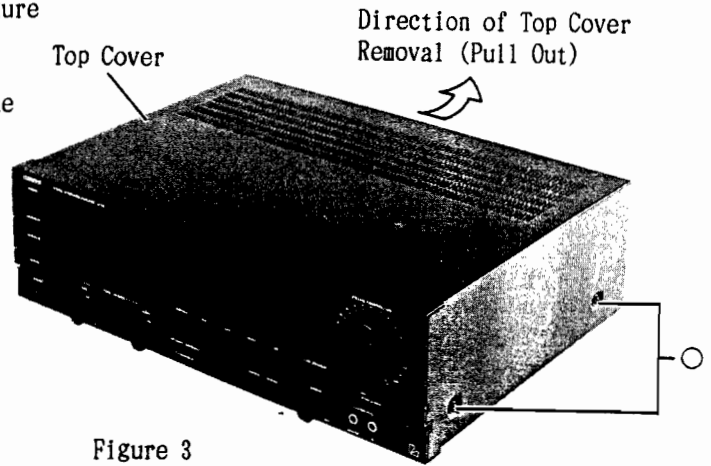

Figure 3

2. Removal of Main P.C. Board

- (1) After removal of the Top Cover, remove eight screws marked "●" and four screws marked "△" as shown in Figure 4 and 5.
- (2) Disconnect all wires from the Main P.C. Board and the P.C. Board with Heatsink can be removed Completely.

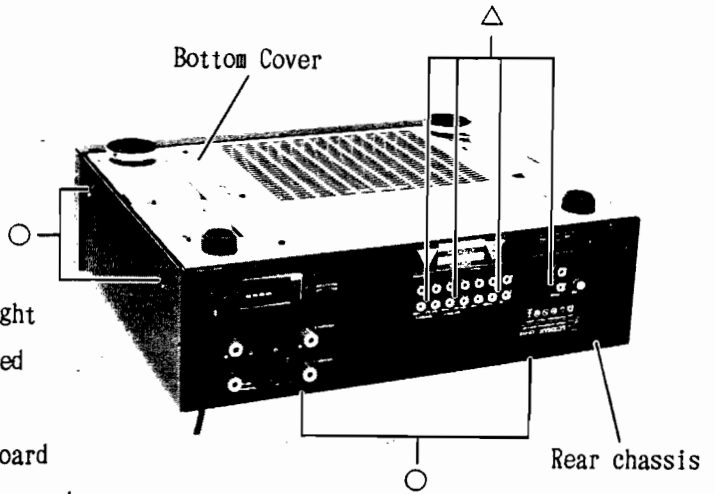

Figure 4

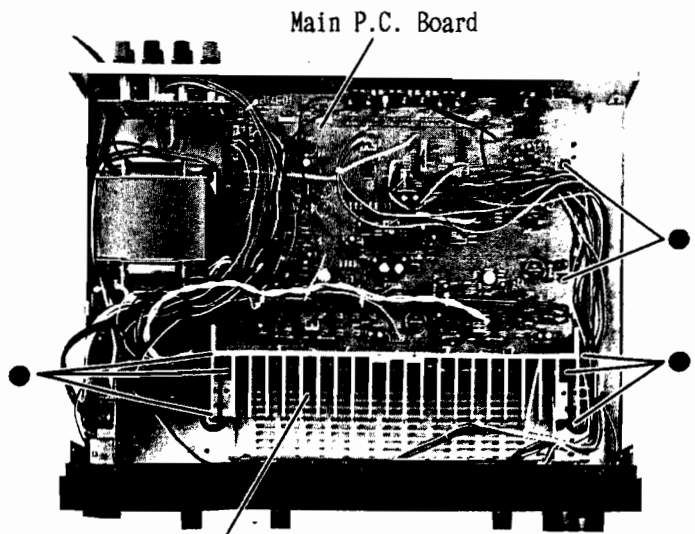

Figure 5

Adjustment Procedures

1. Connection

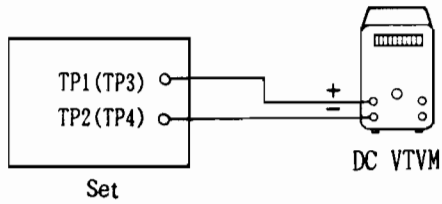

Figure 6

2. Control Setting

- Power Switch.....ON
- Volume Control.....Minimum Position
- Balance Control Center Position
- Treble, Bass Control..... Center Position
- Tone In Switch..... OFF
- REC OUT Selector Switch OFF
- Cartridge Switch.....MM
- SP. Switch.....SP.A
- Others..... OFF
- SP. A Terminal.....8 ohm Load(Both Channel)

3. Adjustment Procedures

Idling Adjustment

Adjust VR7101 (VR7102) until 8 mV is obtained between T.P.1 (T.P.3) and T.P.2 (T.P.4).

Note: This adjustment should be made approx. 30 minutes often the power on or voltage becomes sufficiently steady state.

Adjustment Locations

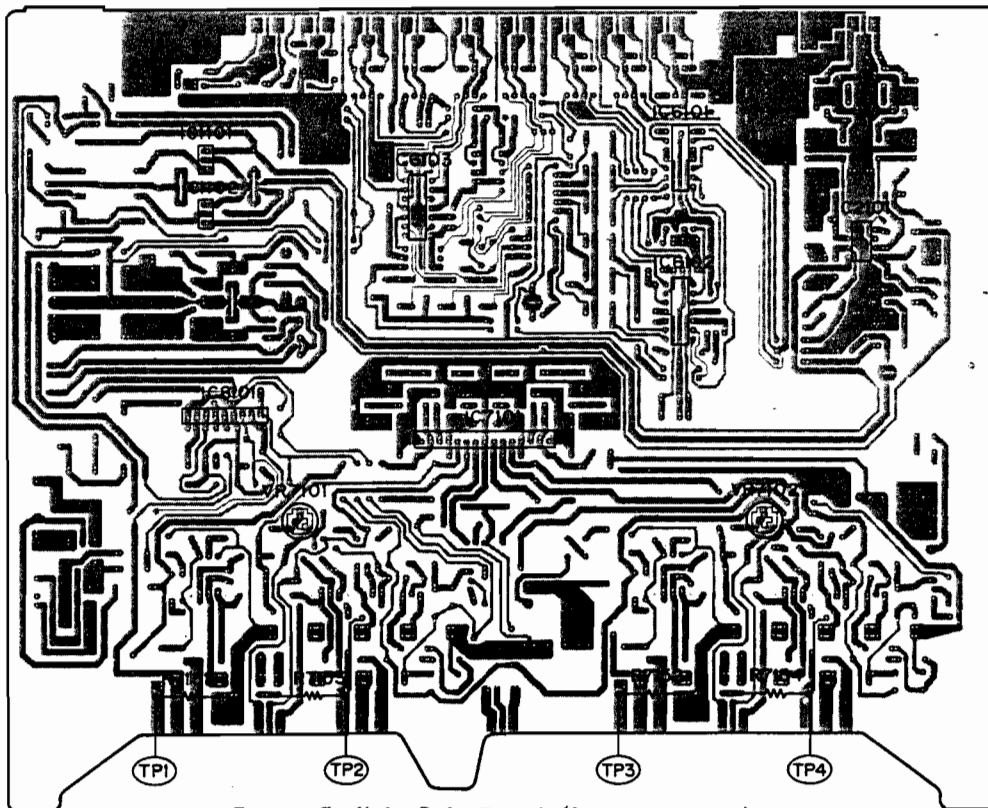
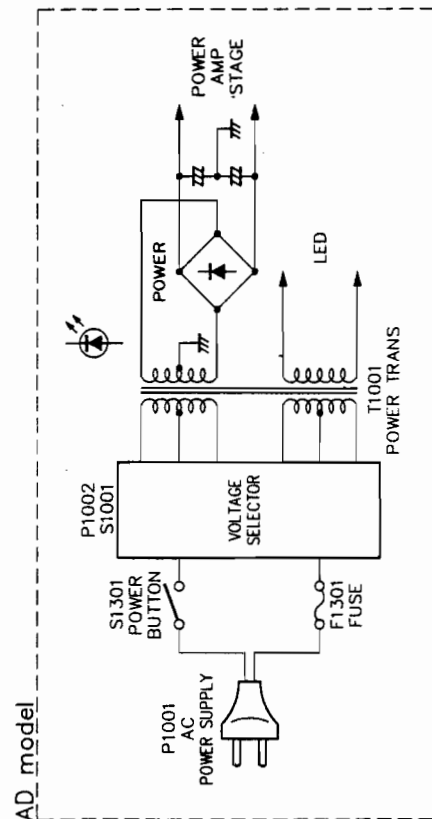
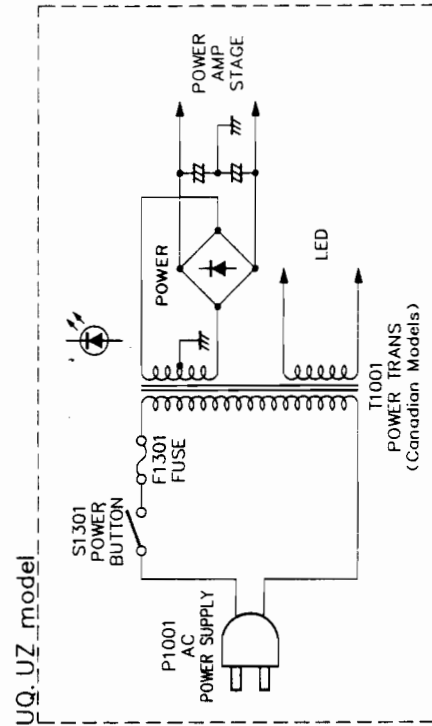
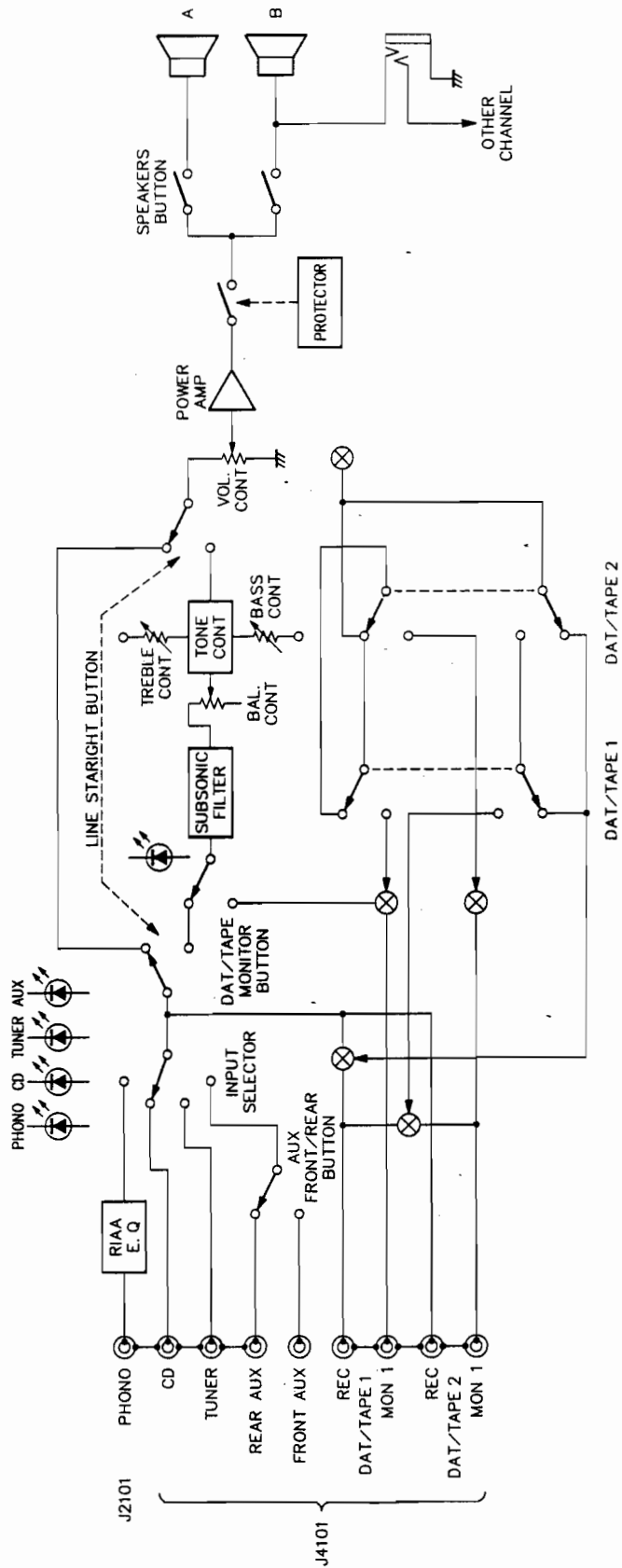

Figure 7 Main P.C. Board (Component Side)

Block Diagram



IC7101

Q7110	Q7104	Q7112	Q7108	Q7118
	Q7102		Q7106	Q7114
	Q7101		Q7105	Q7115
	Q7103	Q7111	Q7107	Q7113
Q7109				Q7117
				Q8101

NOTES:

- All resistance values are in ohms. K = 1,000
- All capacitance values are in microfarads. P = 1/1,000,000

CAUTION:

The Δ mark, the symbol NO. in a box in the schematic diagram and the shaded area in the parts list designate components which have special characteristics important for safety and should be replaced only with types identical to those in the original circuit or specified in the parts list.

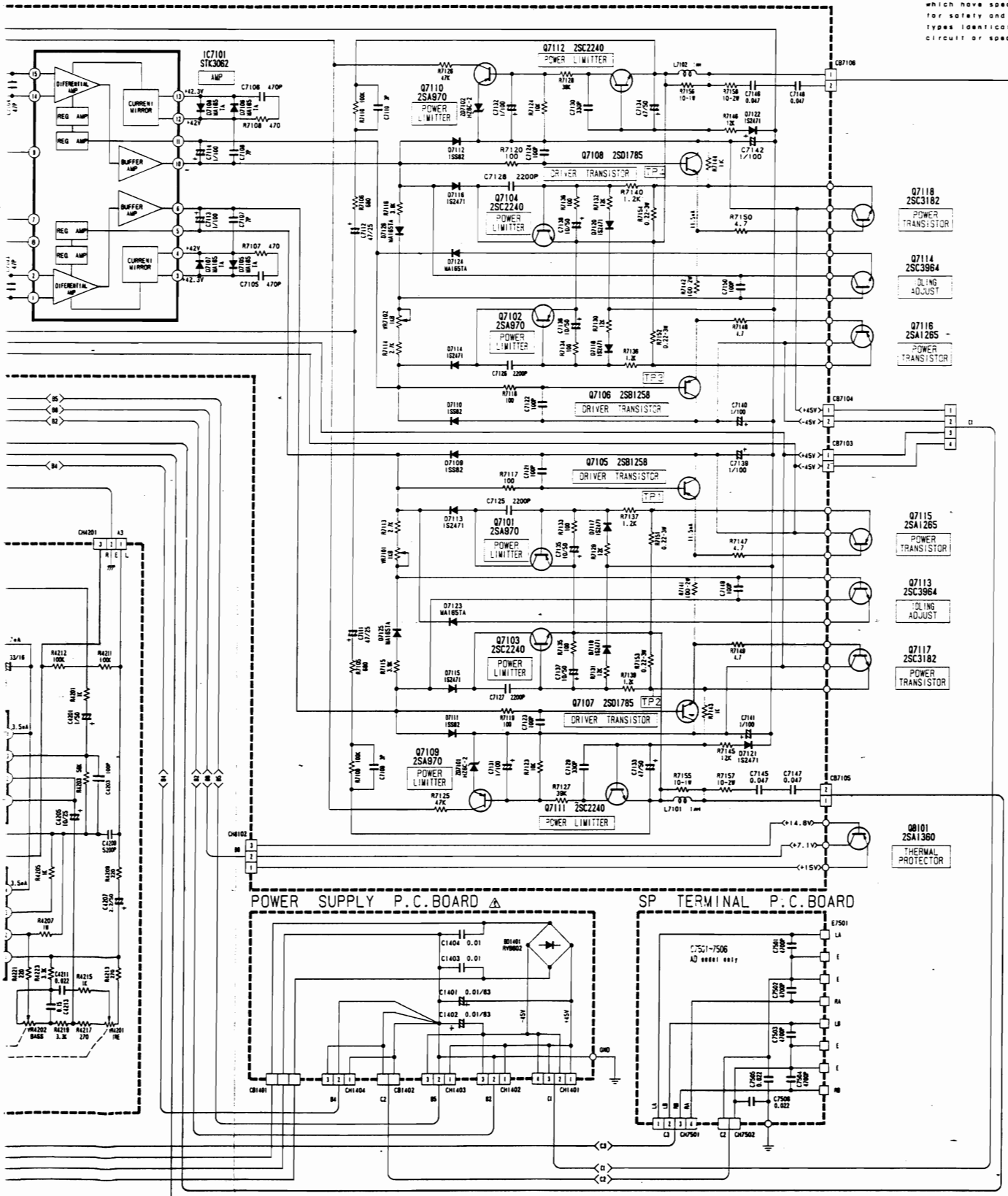

IC2101

1	2	3	4	5	6	7	8
-0.7V	74mV	75mV	-15V	55mV	59mV	-0.7V	15V

IC4201

1	2	3	4	5	6	7	8
0V	0V	0V	-15.5V	0V	0V	0V	15V

IC4202

1	2	3	4	5	6	7	8
0V	0V	0V	-15.5V	0V	0V	0V	15V

IC6101

1	2	3	4	5	6	7
-7mV	0V	-7mV	0V	0V	-15V	-15V
8	9	10	11	12	13	14
-15V	14V	0V	0V	3V	0V	0V

IC6102

1	2	3	4	5	6	7
0V	0V	0V	0V	3V	-15V	14V
8	9	10	11	12	13	14
-15V	-15V	0V	0V	0V	0V	0V

IC6103

1	2	3	4	5	6	7
0V	0V	0V	0V	0V	-15V	-15V
8	9	10	11	12	13	14
-15V	-15V	0V	0V	0V	0V	0V

IC7101

1	2	3	4	5	6	7
-0.2V	-0.2V	42.3V	42V	-1.6V	-1.6V	-42.8V
8	9	10	11	12	13	14
0V	42.8V	1.5V	-1.7V	42V	42.3V	-0.3V

IC8101

1	2	3	4	5	6	7	8	9
-0.6V	-7mV	5mV	2.7mV	-0.7V	0.9V	2.7mV	1.3V	3.1V

	E	C	B		E	C	B
Q7101	-6mV	-1.6V	-19mV	Q7111	-6mV	44V	12mV
Q7102	-6mV	-1.6V	-19mV	Q7112	-6mV	44V	12mV
Q7103	-6mV	1.6V	4mV	Q7113	-0.99V	1.6V	-0.49V
Q7104	-6mV	1.6V	4mV	Q7114	-0.99V	1.6V	
Q7105	-0.6V	-46V	-1.67V	Q7115	-19mV	-46V	-0.6V
Q7106	-0.6V	-45V	-1.6V	Q7116	-19mV	-45V	-0.6V
Q7107	0.6V	46.3V	1.6V	Q7117	7mV	46.3V	0.6V
Q7108	0.6V	45V	1.6V	Q7118	7mV	45V	0.6V
Q7109	40V	-0.6V	44.5V	Q8101	15V	7.1V	14.6V
Q7110	40V	-0.6V	44.5V				

Measuring Conditions
 Power Supply Voltage : AD AC120/220/240V
 : UC/2 AC120V
 Measuring Meter : Digital Multi Voltmeter
 Measuring Point Reference : Between Ground
 Measuring Conditions : No signal input

LV-112

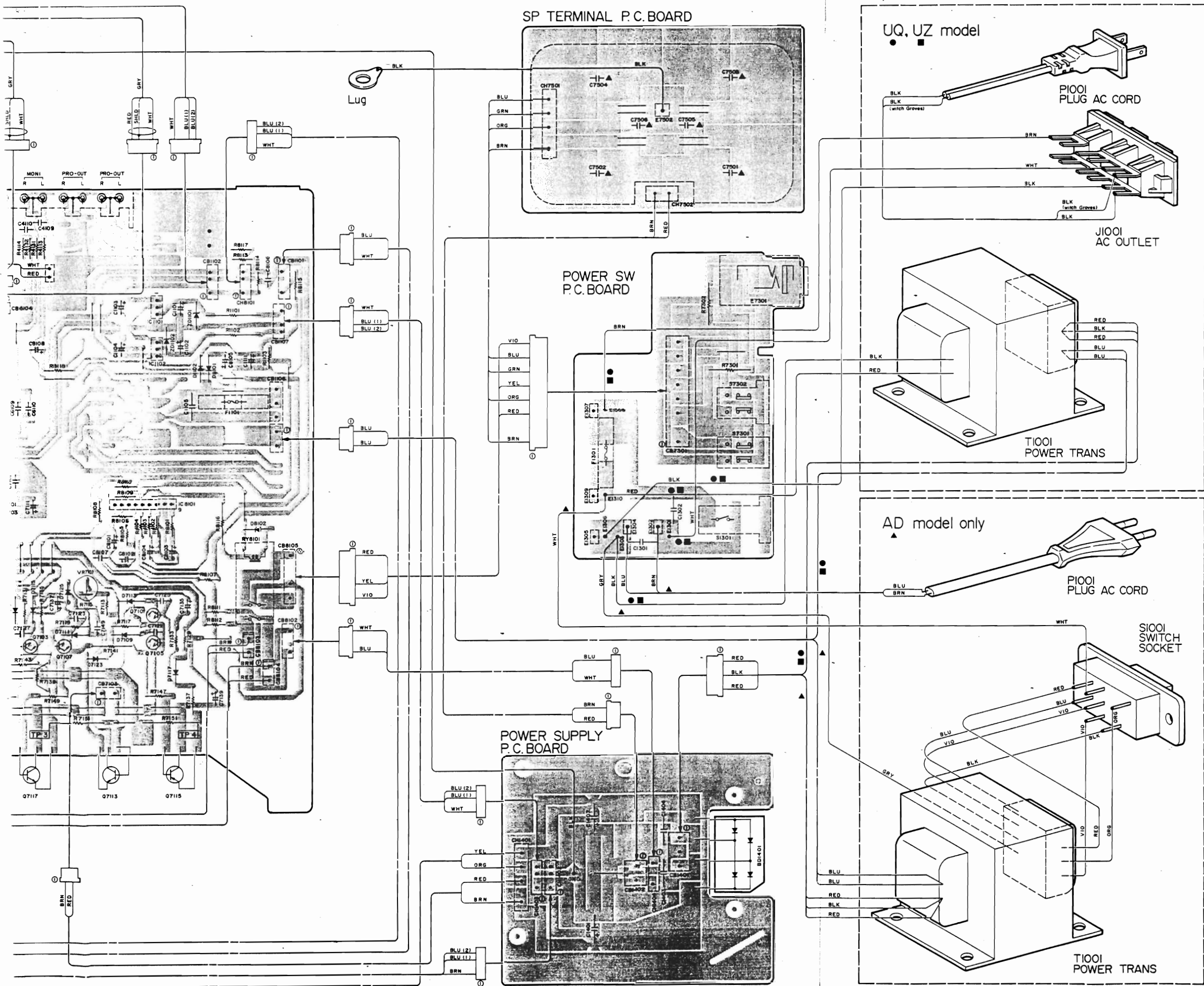

- BLU.....Blue
- GRN.....Green
- BLK.....Black
- GRY.....Gray
- WHT.....White
- RED.....Red
- YEL.....Yellow
- VIO.....Violet
- BLK/WHT-Black
- SHLD.....Shield

Electrical Parts List

Resistor: Carbon resistors under 1/8 watts are not mentioned in the parts list, please confirm them by schematic diagram.

Capacitor: μF -microfarads, pF-picofarads

Abbreviations		
CAP.-Capacitor	CER.-Ceramic	
ELY.-Electrolytic	LED.-Light Emitting Diode	
MIC.-Mica	MO.-Metal Oxide Film	
MYL.-Mylar	PP.-Polypropylene	
SOL.-Solid	ZEN.-Zener	

Symbol No.	Part No.	Description
Main P.C. Board		
IC's		
IC1101	51T82394F01	NJM7815FA
IC1102	51T82395F01	NJM7915FA
IC2101	51T00038L01	M5220P -
IC6101	51T80864F01	CX-770
IC6102	51T80864F01	CX-770
IC6103	51T80864F01	CX-770
IC7101	51T68833F01	STK3062
IC8101	51T67437F01	TA7317P
Transistors		
Q7101	48T52543F03	2SA970
Q7102	48T52543F03	2SA970
Q7103	48T53301F02	2SC2240
Q7104	48T53301F02	2SC2240
Q7105	48T94820F01	2SB1258
Q7106	48T94820F01	2SB1258
Q7107	48T94821F01	2SD1785
Q7108	48T94821F01	2SD1785
Q7109	48T52543F03	2SA970
Q7110	48T52543F03	2SA970
Q7111	48T53301F02	2SC2240
Q7112	48T53301F02	2SC2240
Diodes		
D1102	48S40477U01	1N4003
D6101	48T44813F01	MA165TA
D6102	48T44813F01	MA165TA
D6103	48T44813F01	MA165TA
D6104	48T44813F01	MA165TA
D6105	48T44813F01	MA165TA
D6106	48T44813F01	MA165TA
D6107	48T44813F01	MA165TA
D6108	48T44813F01	MA165TA
D6109	48T44813F01	MA165TA

Symbol No.	Part No.	Description
D7101	48T44813F01	MA165TA
D7102	48T44813F01	MA165TA
D7103	48T44813F01	MA165TA
D7104	48T44813F01	MA165TA
D7105	48T44813F01	MA165TA
D7106	48T44813F01	MA165TA
D7107	48T44813F01	MA165TA
D7108	48T44813F01	MA165TA
D7109	48T73079F02	1SS82
D7110	48T73079F02	1SS82
D7111	48T73079F02	1SS82
D7112	48T73079F02	1SS82
D7113	48T68764F01	1S2471
D7114	48T68764F01	1S2471
D7115	48T68764F01	1S2471
D7116	48T68764F01	1S2471
D7117	48T68764F01	1S2471
D7118	48T68764F01	1S2471
D7119	48T68764F01	1S2471
D7120	48T68764F01	1S2471
D7121	48T68764F01	1S2471
D7122	48T68764F01	1S2471
D7123	48T44813F01	MA165TA
D7124	48T44813F01	MA165TA
D7125	48T44813F01	MA165TA
D7126	48T44813F01	MA165TA
D8101	48S40477U01	1N4003
D8102	48S40477U01	1N4003
ZD1101	48T52739F99	ZEN. HZ30-3
ZD1102	48T52739F99	ZEN. HZ30-3
ZD7101	48T52739F41	ZEN. HZ6C-2
ZD7102	48T52739F41	ZEN. HZ6C-2
Inductors		
▲ L2101	24T83130F02	33 μH
▲ L2102	24T83130F02	33 μH
▲ L2103	24T83130F02	33 μH
▲ L2104	24T83130F02	33 μH
L7101	24T74372F02	VERTI 1 μH
L7102	24T74372F02	VERTI 1 μH

Note: ▲ : For West Germany model only (AD) Others : Common
 ● : For Canada model only (UQ)
 ■ : For North American model only (UZ)

Symbol No.	Part No.	Description			Symbol No.	Part No.	Description		
Capacitors									
	C1101	23T00149L67	ELY. 33 μ F/63V		C6104	08T52714F13	CER. 0.01 μ F		
	C1102	23T00149L67	ELY. 33 μ F/63V		C6105	08T52714F13	CER. 0.01 μ F		
	C1103	23T00149L37	ELY. 220 μ F/25V		C6106	08T52714F13	CER. 0.01 μ F		
	C1104	23T00149L37	ELY. 220 μ F/25V		C6107	08T52714F13	CER. 0.01 μ F		
	C1105	21T68834F01	CER. 0.01 μ F		C6108	08T52714F13	CER. 0.01 μ F		
▲	C1111	23T00149L58	ELY. 33 μ F/50V		C6109	08T52714F13	CER. 0.01 μ F		
●	C1111	23T00149L36	ELY. 100 μ F/25V		C6110	08T57298F01	CER. 0.1 μ F		
■	C1111	23T00149L36	ELY. 100 μ F/25V		C6111	23T00149L36	ELY. 100 μ F/25V		
▲	C2101	21S40655F22	CER. 82pF		C6112	23T00149L36	ELY. 100 μ F/25V		
▲	C2102	21S40655F22	CER. 82pF		C7101	08S40805F01	CER. 100pF		
▲	C2103	08S40805F03	CER. 220pF		C7102	08S40805F01	CER. 100pF		
●	C2103	08S40805F01	CER. 100pF		C7103	08T61939F27	CER. 47pF		
■	C2103	08S40805F01	CER. 100pF		C7104	08T61939F27	CER. 47pF		
▲	C2104	08S40805F03	CER. 220pF		C7105	08S40805F05	CER. 470pF		
●	C2104	08S40805F01	CER. 100pF		C7106	08S40805F05	CER. 470pF		
■	C2104	08S40805F01	CER. 100pF		C7107	08T81196F05	MIC. 7pF		
	C2105	23T00149L55	ELY. 4.7 μ F/50V		C7108	08T81196F05	MIC. 7pF		
	C2106	23T00149L55	ELY. 4.7 μ F/50V		C7109	08T81196F03	MIC. 3pF		
	C2109	23T42478F31	ELY. 47 μ F/25V		C7110	08T81196F03	MIC. 3pF		
	C2110	23T42478F31	ELY. 47 μ F/25V		C7111	23T42478F31	ELY. 47 μ F/25V		
	C2111	08T57705F74	MYL. 0.039 μ F		C7112	23T42478F31	ELY. 47 μ F/25V		
	C2112	08T57705F74	MYL. 0.039 μ F		C7113	23T00149L74	ELY. 1 μ F/100V		
	C2113	08T57705F67	MYL. 0.01 μ F		C7114	23T00149L74	ELY. 1 μ F/100V		
	C2114	08T57705F67	MYL. 0.01 μ F		C7115	23T00149L69	ELY. 100 μ F/63V		
	C2117	23T00149L74	ELY. 1 μ F/100V		C7116	23T00149L69	ELY. 100 μ F/63V		
	C2118	23T00149L74	ELY. 1 μ F/100V		C7121	08T81196F34	MIC. 100pF		
	C2119	08T57705F58	MYL. 1800pF		C7122	08T81196F34	MIC. 100pF		
	C2120	08T57705F58	MYL. 1800pF		C7123	08T81196F34	MIC. 100pF		
	C2121	23T00149L36	ELY. 100 μ F/25V		C7124	08T81196F34	MIC. 100pF		
	C2122	23T00149L36	ELY. 100 μ F/25V		C7125	08T57705F09	MYL. 2200pF		
	C2123	08T57298F01	CER. 0.1 μ F		C7126	08T57705F09	MYL. 2200pF		
	C2124	08T57298F01	CER. 0.1 μ F		C7127	08T57705F09	MYL. 2200pF		
▲	C4101	08S40805F01	CER. 100pF		C7128	08T57705F09	MYL. 2200pF		
▲	C4102	08S40805F01	CER. 100pF		C7129	08S40805F04	CER. 330pF		
▲	C4103	08S40805F01	CER. 100pF		C7130	08S40805F04	CER. 330pF		
▲	C4104	08S40805F01	CER. 100pF		C7131	23T00149L74	ELY. 1 μ F/100V		
▲	C4105	08S40805F01	CER. 100pF		C7132	23T00149L74	ELY. 1 μ F/100V		
▲	C4106	08S40805F01	CER. 100pF		C7133	23T00149L59	ELY. 47 μ F/50V		
▲	C4107	08S40805F01	CER. 100pF		C7134	23T00149L59	ELY. 47 μ F/50V		
▲	C4108	08S40805F01	CER. 100pF		C7135	23T00149L56	ELY. 10 μ F/50V		
▲	C4109	08S40805F01	CER. 100pF		C7136	23T00149L56	ELY. 10 μ F/50V		
▲	C4110	08S40805F01	CER. 100pF		C7137	23T00149L56	ELY. 10 μ F/50V		
	C6101	08T52714F13	CER. 0.01 μ F		C7138	23T00149L56	ELY. 10 μ F/50V		
	C6102	08T52714F13	CER. 0.01 μ F		C7139	23T00149L74	ELY. 1 μ F/100V		
	C6103	08T52714F13	CER. 0.01 μ F		C7140	23T00149L74	ELY. 1 μ F/100V		

Note: ▲ : For West Germany model only (AD) Others : Common

● : For Canada model only (UQ)

■ : For North American model only (UZ)

Symbol No.	Part No.	Description		
C7141	23T00149L74	ELY. 1 μ F/100V		
C7142	23T00149L74	ELY. 1 μ F/100V		
C7143	23T00149L74	ELY. 1 μ F/100V		
C7144	23T00149L74	ELY. 1 μ F/100V		
C7145	08T40658F70	CER. 0.047 μ F		
C7146	08T40658F70	CER. 0.047 μ F		
C7147	08T40658F70	CER. 0.047 μ F		
C7148	08T40658F70	CER. 0.047 μ F		
C7149	08S40805F01	CER. 100pF		
C7150	08S40805F01	CER. 100pF		
C8101	23T00149L23	ELY. 47 μ F/16V		
C8102	23T00149L74	ELY. 1 μ F/100V		
C8103	23T00149L21	ELY. 22 μ F/16V		
C8104	23T00149L51	ELY. 0.47 μ F/50V		
C8105	23T00149L53	ELY. 2.2 μ F/50V		
C8106	08S40805F11	CER. 2200pF		
C8107	08T52714F13	CER. 0.01 μ F		
C8108	23T00149L36	ELY. 100 μ F/25V		
Resistors				
R1101	06T92264F46	MF. 750 ohm 2W		
R1102	06T92264F46	MF. 750 ohm 2W		
R7111	06T69013F41	Fuse. 100 ohm 1/4W		
R7112	06T69013F41	Fuse. 100 ohm 1/4W		
R7141	06T92264F25	MF. 100 ohm 2W		
R7142	06T92264F25	MF. 100 ohm 2W		
R7151	06T92262F01	MF. 0.22 ohm 3W		
R7152	06T92262F01	MF. 0.22 ohm 3W		
R7153	06T92262F01	MF. 0.22 ohm 3W		
R7154	06T92262F01	MF. 0.22 ohm 3W		
R7155	06T92263F01	MF. 10 ohm 1W		
R7156	06T92263F01	MF. 10 ohm 1W		
R7157	06T92264F01	MF. 10 ohm 2W		
R7158	06T92264F01	MF. 10 ohm 2W		
R8116	06T92264F49	MF. 1K ohm 2W		
VR7101	18C41732G07	SOL. Variable 1KB		
VR7102	18C41732G07	SOL. Variable 1KB		
Relay				
RL8101	80T95099F02	DH24D2-0T(M)		
Jacks				
J2101	09T72605F01	Plate. Pin-Jack-2p (Phono)		
J4101	09T72606F03	Plate. PH 14P (CD. Tuner. LD. REC1. Moni1. REC2. Moni2)		

Note: ▲ : For West Germany model only(AD) Others : Common

● : For Canada model only(UQ)

■ : For North American model only (UZ)

Symbol No.	Part No.	Description		
Function P.C. Board				
Ic's				
IC4201	51T52383F01	NJM4558D		
IC4202	51T52383F01	NJM4558D		
Diodes				
LD8201	48T66616F02	LED. SLR-54VR3 (RED)		
LD8202	48T66616F02	LED. SLR-54VR3 (RED)		
LD8203	48T66616F02	LED. SLR-54VR3 (RED)		
LD8204	48T66616F02	LED. SLR-54VR3 (RED)		
LD8205	48T66616F02	LED. SLR-54VR3 (RED)		
LD8206	48T66616F02	LED. SLR-54VR3 (RED)		
Switches				
S6201	40T95030F01	Push. SPEC23 (LOUDNESS)		
S6202	40T83838F01	Push. 1P (LINE/STRAIGHT)		
S6204	40T95034F01	Push. SPEA51 (INPUT SELECTOR)		
S6205	40T95063F01	Push. SPEC12 (FRONT/PEAR)		
S6206	40T95064F01	Push. SPEC23 (TAPE 1/2)		
Capacitors				
C1201	23S57007F13	ELY. 33 μ F/16V		
C1202	23S57007F13	ELY. 33 μ F/16V		
C4201	23S57007F05	ELY. 1 μ F/50V		
C4202	23S57007F05	ELY. 1 μ F/50V		
C4203	08S40805F01	CER. 100pF		
C4204	08S40805F01	CER. 100pF		
C4205	23S57007F21	ELY. 10 μ F/25V		
C4206	23S57007F21	ELY. 10 μ F/25V		
C4207	23S57007F06	ELY. 2.2 μ F/50V		
C4208	23S57007F06	ELY. 2.2 μ F/50V		
C4209	08S40805F16	CER. 5600pF		
C4210	08S40805F16	CER. 5600pF		
C4211	08T57705F21	MYL. 0.022 μ F		
C4212	08T57705F21	MYL. 0.022 μ F		
C4213	08T57851F15	TF. 0.15 μ F		
C4214	08T57851F15	TF. 0.15 μ F		
C6201	08T57705F04	MYL. 820pF		
C6202	08T57705F04	MYL. 820pF		
C6203	08T57705F19	MYL. 0.015 μ F		
C6204	08T57705F19	MYL. 0.015 μ F		
C6205	08T57851F18	TF. 0.27 μ F		
C6206	08T57851F18	TF. 0.27 μ F		

Symbol No.	Part No.	Description		
Resistors				
VR4201	18T95027F01	Variable. K162 10KBx2 (TRE)		
VR4202	18T95027F01	Variable. K162 10KBx2 (BASS)		
VR6201	18T71727F01	Variable. RKDAOO 100KBx2 (VOL)		
VR6202	18T95028F01	Variable. K162 250KMN (BAL)		
Power SW P.C. Board				
Switches				
S1301	40T92255F02	Push. SDLP 1P (POWER)		
S7301	40T95032F01	Push. SPUN19 (SP.A)		
S7302	40T95031F01	Push. SPUN12 (SP.B)		
Capacitors				
C1301	08T57437F09	CER. 0.01 μ F		
C1302	08T57437F09	CER. 0.01 μ F		
Resistors				
R7301	06T92264F33	MF. 220 ohm 2W		
R7302	06T92264F33	MF. 220 ohm 2W		
Jack				
J7301	09T52845F12	HD M1658AYCA		
SP Terminal P.C. Board				
Capacitors				
▲ C7501	08S40805F15	CER. 4700pF		
▲ C7502	08S40805F15	CER. 4700pF		
▲ C7503	08S40805F15	CER. 47000F		
▲ C7504	08S40805F15	CER. 4700pF		
▲ C7505	08S40805F21	CER. 0.022 μ F		
▲ C7506	08S40805F21	CER. 0.022 μ F		
Terminal				
▲ E7501	09T83850F01	SP 8P		
● E7501	09T83850F03	SP 8P		
■ E7501	09T83850F03	SP 8P		

Symbol No.	Part No.	Description		
Power Supply P.C. Board				
Diode				
BD1401	48T81924F01	Bridge RBV-602		
Capacitors				
C1401	23T72607F01	ELY. 0.01 μ F/63V		
C1402	23T72607F01	ELY. 0.01 μ F/63V		
C1403	21T688834F01	CER. 0.01 μ F		
C1404	21T688834F01	CER. 0.01 μ F		
Miscellaneous				
J9901	09T80329F01	Plate. Phono		
J9902	09T80329F02	Plate. Phono		
LD8701	48T66616F02	LED. SLR-54VR3 (RED)		
▲ P1001	28T43812P04	Plug. AC Cord		
● P1001	28T55335F02	Plug. AC Cord		
■ P1001	28T55335F02	Plug. AC Cord		
▲ P1002	09T51830F01	Plug. SW		
Q7113	48T92782F01	Tr. 2SC3964		
Q7114	48T92782F01	Tr. 2SC3964		
Q7115	48T58610F01	Tr. 2SA1265		
Q7116	48T58610F01	Tr. 2SA1265		
Q7117	48T58609F01	Tr. 2SC3182		
Q7118	48T58609F01	Tr. 2SC3182		
Q8101	48T64375F01	Tr. 2SA1360		
▲ S1001	09T51831F01	Socket SW		
▲ T1001	25T95045F01	Trans. Power		
● T1001	25T95045F02	Trans. Power		
■ T1001	25T95045F02	Trans. Power		
▲ F1101	65T42077U16	Fuse. Semko 1A		
● F1101	65T66926F14	Fuse. 51NM 1.25A		
■ F1101	65T66926F14	Fuse. 51NM 1.25A		
▲ F1301	65T42077U21	Fuse. Semko 3.15A		
● F1301	65T66926F19	Fuse. 51NM 5A		
■ F1301	65T66926F19	Fuse. 51NM 5A		
● J1001	09T68841F03	Outlet. AC		
■ J1001	09T68841F03	Outlet. AC		

Note: ▲ : For West Germany model only (AD) Others : Common
 ● : For Canada model only (UQ)
 ■ : For North American model only (UZ)

Packing Method View

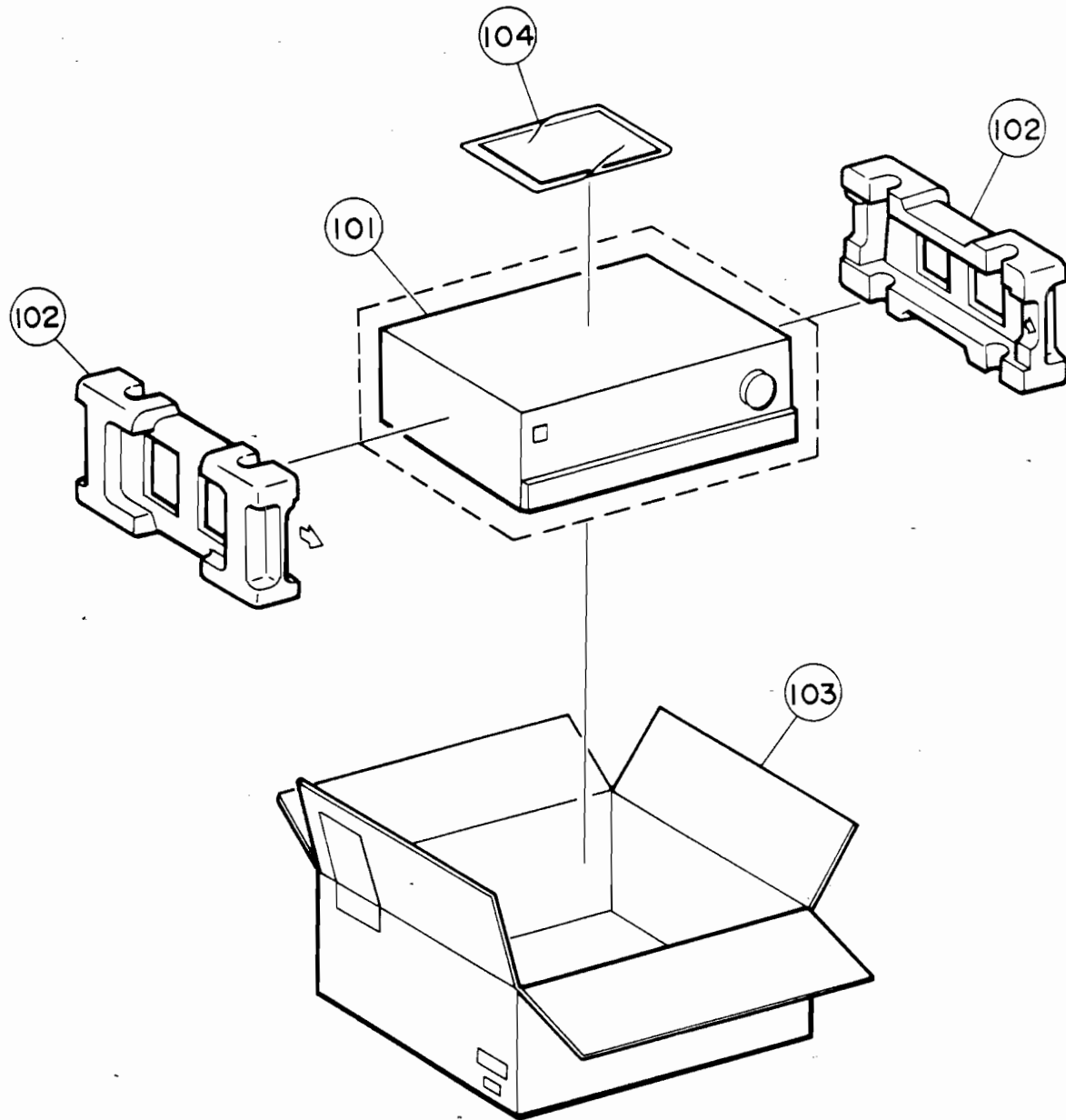

Packing Assembly Parts List

Symbol No.	Part No.	Description		
101	56B40442T08	Packing, Front Frame		
102	56D94704F01	Tray, Packing		
103	56S83833F41	Cartor. Packing		
104	68P81707F04	Owners, Manual		

Cabinet Assembly Parts List

Note: The parts without part numbers are not supplied.

Symbol No.	IN-dex	Part No.	Description	Symbol No.	IN-dex	Part No.	Description
	1	2-A	01V94400F27	Assy.. Front Panel			
	2	1-D	15D72658F01	Cover. Top			
▲	5	2-H	15D94698F01	Cover. Rear			
●	5	2-H	15D94698F02	Cover. Rear			
■	5	2-H	15D94698F07	Cover. Rear			
	6	4-A	36B70885F07	Knob. Power			
	7	4-A	36B83814F01	Knob. Speaker			
	8	5-A	36A72661F01	Knob. Push Tone			
	9	5-A	36A67333F01	Knob. Push (3x10)			
	10	4-B	36B67336F02	Knob. Main Volume			
	11	3-A	36A74341F02	Knob. Tone Volume			
	12	5-F	75T57059F01	Pad. Trannieg			
	13	4-D	75A96563F01	Pad. Trannieg			
	14	3-D	03S40018G02	Scr.. TPG (M3x8)			
	15		03S44205G52	Scr. Pan (M4x14)			
	16		03S71031F04	Scr.. Bind (M3x8)			
	17		03S40036U01	Scr.. W/Washer (M4x8)			
▲	18	1-H	15A82362F01	Cover. V-Sele			
▲	19	1-H	03S71677F18	Scr.. Pan (M3x12)			
	20	2-D	03S40018G12	Scr.. TPG (M3x10)			
	22	2-A	03S71031F09	Scr.. Countersink (M3x8)			
	23	1-G	14S53018F42	Insulator			
	27		03C40121T18	Bolt Hex W/Double Washer (M3x10)			
	29		03S40018G08	Scr.. TPG (M3x8)			
	30		29C41045P05	Lug. Wrap 54mm			
	31		03A82468F01	Scr.. TPG (M3x10)			
	32		03S71031F03	Scr.. Bind (M3x6)			
▲	34		14A82952F10	Insulator. V-Sele			
▲	35	1-D	01T15036W03	Assy.. Conn. 1P			
	37	1-G	43B41625J02	Support. Cord			
	38	2-H	29T66964F01	Terminal. GND			
	40	4-A	03S43997P42	Scr.. Countersink (M3x5)			
	41	4-C	05B41835J02	Rivet. Push			
	43	4-B	43A41837U04	Spacer. LED			
	44	4-C	09T84840F02	Lug. Style 32mm			
▲	46	4-C	43T53136F04	Bush. Cap			
	47		09T51410F01	Holder. Fuse			
	49	5-A	43A41837U02	Spacer. LED			
	51	6-B	14A96023F01	Insulator. Jack			

Note: ▲: For West Germany model only (AD) Others: Common

●: For Canada model only (UQ)

■: For North American model only (UZ)

Exploded View (Cabinet)

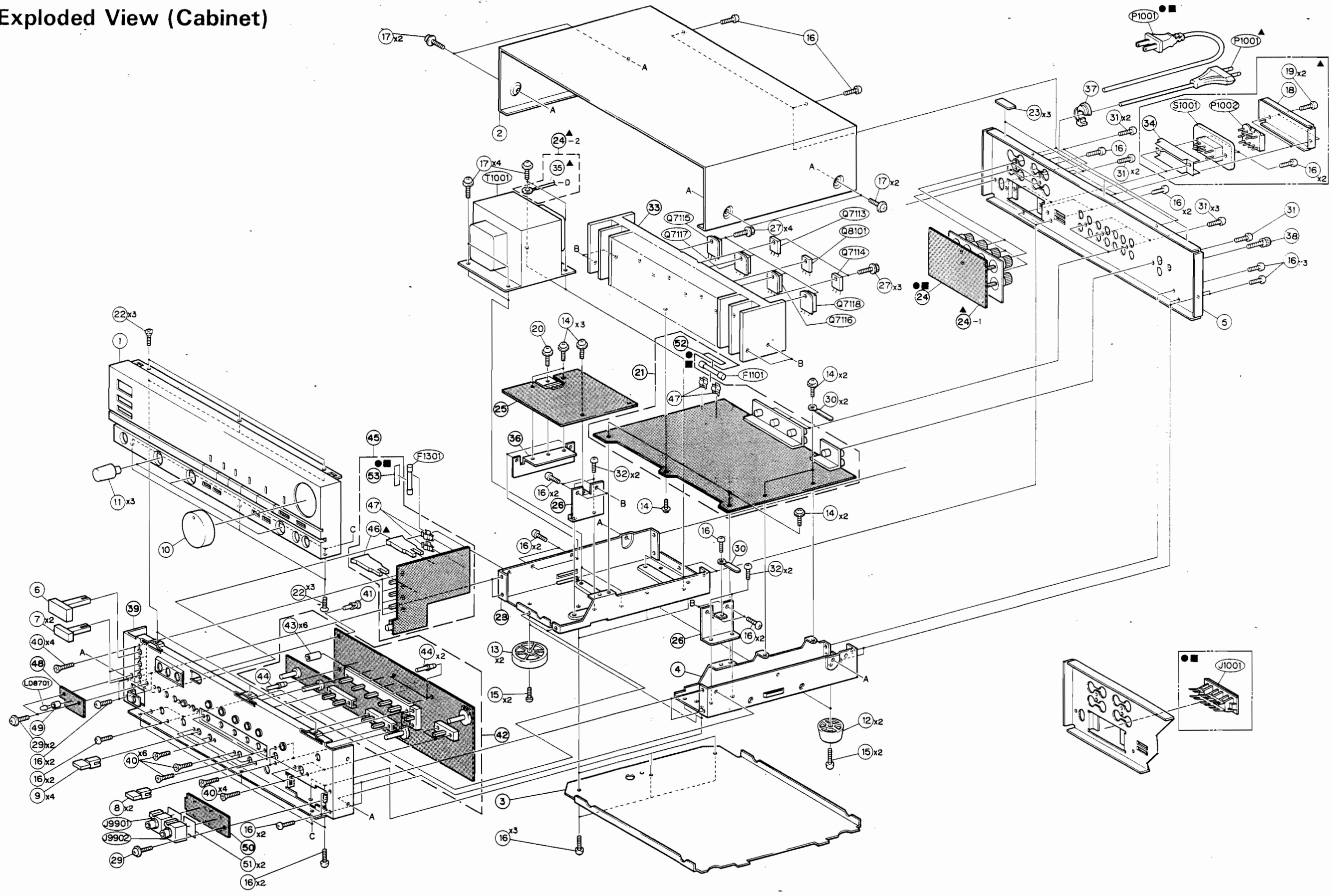

Semi-Conductor Lead Identification

NJM7815FA: IC1101

1. Output
2. Common
3. Input

NJM7915FA: IC1102

1. Output
2. Input
3. Common

M5220P: IC2101

V+ 8, OUT2 7, Ii2 6, IN2 5, OUT1 1, Ii1 2, IN1 3, V- 4

NJM4558D: IC4201, 4202

A -OUTPUT 1, A -INPUT 2, A +INPUT 3, V- 4, B -OUTPUT 7, B -INPUT 6, B +INPUT 5, V+ 8

TA7317P: IC8101

INPUT 1 1, INPUT 2 2, INPUT 3 3, MUTE 8, Vcc 9, Dis, Charge 7, GND 4, Vss 5, OUT PUT 6

STK3062: IC7101

INPUT 1 15, NF 1 14, +B 9, -B 7, GROUND 8, NF 2 13, INPUT 2 12, OUT 1 11, OUT 2 10, OUT 2 6, OUT 1 5, INPUT 2 4, NF 2 3

CX770:IC6101, 6102, 6103

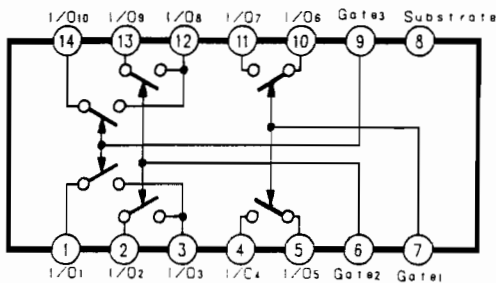
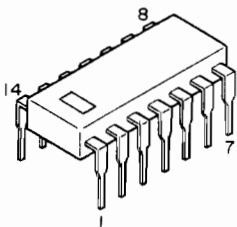

2SC3964:Q7113, 7114
2SA1360:Q8101

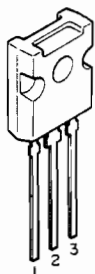

- 1. Emitter
- 2. Collector
- 3. Base

2SA1265:Q7115, 7116
2SC3182:Q7117, 7118

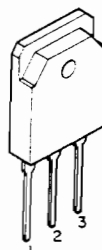

- 1. Base
- 2. Collector
- 3. Emitter

2SA970:Q7101, 7102, 7109, 7110
2SC2240:Q7103, 7104, 7111, 7112



- 1. Emitter
- 2. Collector
- 3. Base

2SB1258:Q7105, 7106
2SD1785:Q7107, 7108



- 1. Base
- 2. Collector
- 3. Emitter