

SERVICE MANUAL

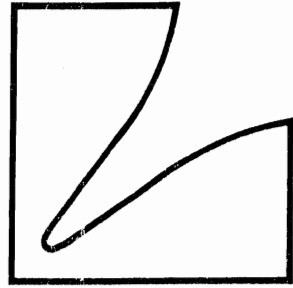

Stereo Integrated Amplifier

LV-113

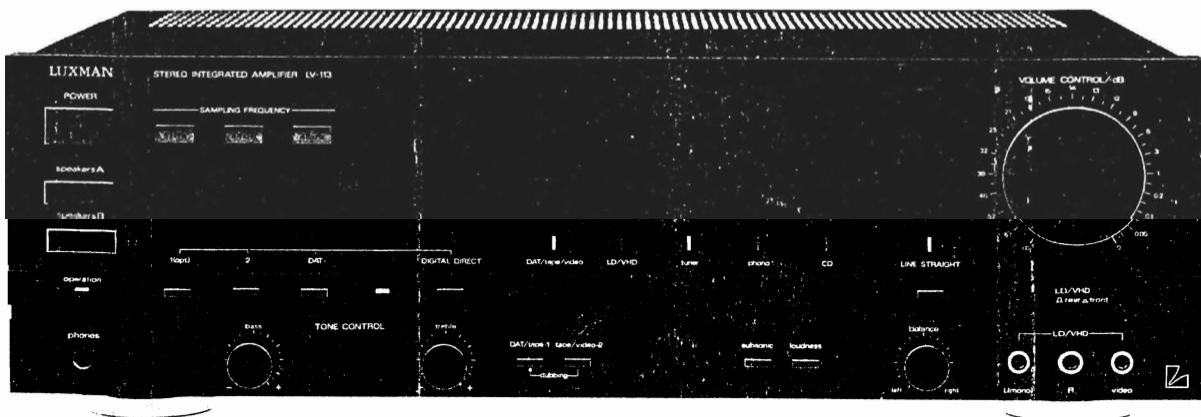

Contents

Specifications	2
Parts Locations	3
Disassembly Instructions	4
Adjustment Procedures	5
Adjustment Locations	6
Block Diagram	7 to 8
Parts Layout on P. C. Boards and Wiring Diagram (1/2)	9 to 11
Parts Layout on P. C. Boards and Wiring Diagram (2/2)	12 to 14
Schematic Diagram (1/2)	15 to 17
Schematic Diagram (2/2)	18 to 20
Electrical Parts List	21 to 27
Cabinet Assembly Parts List	28
Exploded View (Cabinet)	29 to 30
Packing Assembly Parts List	31
Packing Method View	31
Semi-Conductor Lead Identifications	32 to 37

Specifications

Power Output	65W (20Hz~20kHz)
Headphones Output	(65W/8 ohms, 1kHz) : 800mV ± 50%
Input Sensitivity (1kHz)	DAT/Tape-1, VCR/Tape-2 : 150mV ± 20%
	Phono (MM) : 2.5mV ± 0.5%
Input Impedance (1kHz)	DAT/Tape-1, VCR/Tape-2 : 40k ohm ± 5%
	Phono (MM) : 47k ohm ± 5%
Frequency Response	DAT/Tape-1, VCR/Tape-2 : (10Hz~100kHz) +0.6~5dB
	CD, Tuner, F.R.LD/VHD (LS ON) : (10Hz~100kHz) +0.6~3dB
	Phono (MM) : (100Hz) 13.09 ± 1dB
	Phono (MM) : (10kHz) -13.74 ± 1dB
Loudness Control (VR-30dB)	(100Hz) 6 ± 2dB
	(10kHz) 4 ± 2dB
Tone Controls	Bass : (100Hz) ± 10 ± 3dB
	Treble : (10kHz) ± 10 ± 3dB
S/N Ratio	
(In Put Terminals Shorted)	CD, Tuner, F.R.LD/VHD (LS ON) : 83.6dB
	DAT/Tape-1, VCR/Tape-2 : 77.6dB
	Phono (MM) (SUB F ON) : 65.6dB
Cross Talk (10kHz)	CD, Tuner, F.R.LD/VHD (LS ON) : 40dB
Residual Noise	1.2mV
Power Supply	120/220/240V, 50Hz (AD Model Only)
	120V, 60Hz (UZ/UQ Model Only)
	100V, 50/60Hz (JA Model Only)
Dimension	438 (W) × 137 (H) × 382 (D) mm
Weight	9.8kg
Semiconductors	49 Diodes, 4 Zener Diodes
	33 Transistors, 2 Bridge Diodes
	25 IC's (JA/UZ), 24 IC's (AD)

Note : Due to continuing product improvement, specifications and design are subject to change without notice.

Parts Locations

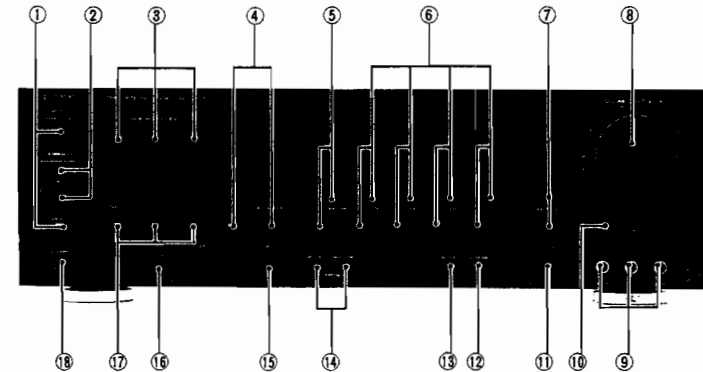

Figure 1
<2 回>

- POWER Button and Indicator
- SPEAKERS A and B Buttons
- SAMPLING FREQUENCY Indicators
- DIGITAL DIRECT Button and Indicator
- MONITOR (DAT/Tape/Video) Button and Indicator
- INPUT SELECTOR Buttons and Indicators
- LINE STRAIGHT Button and Indicator
- VOLUME Control
- LD/VHD FRONT Input Jacks
- FRONT/REAR Button
- BALANCE Control
- LOUDNESS Button
- SUBSONIC Filter Button
- DAT/TAPE-1 and TAPE/VIDEO-2 Buttons
- TREBLE Control
- BASS Control
- DIGITAL DIRECT 1 (OPT.), 2 and DAT Selector Buttons
- PHONES Jack

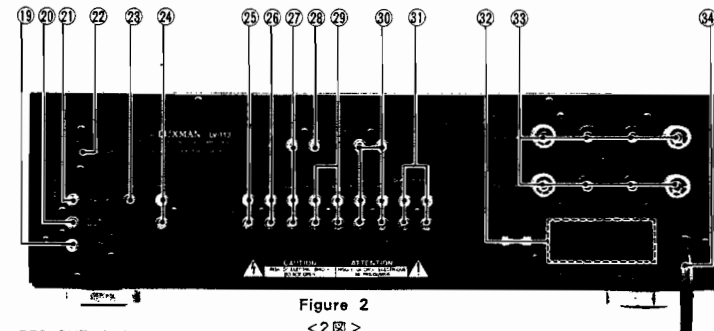

Figure 2
<2 回>

- DIGITAL REC OUT Jack
- DIGITAL NONI Jack
- DIGITAL IN-2 Jack
- DIGITAL IN-1 (OPT.) Jack
- GND Terminal
- PHONO Jacks
- CD Jacks
- TUNER Jacks
- LD/VHD REAR Input Jacks
- VIDEO MONITOR Jack
- DAT/TAPE-1 REC OUT and MONI Jacks
- TAPE/VIDEO-2 Jacks
- SIGNAL PROCESSOR IN and OUT Jacks
- AC Outlets
- SPEAKER Terminals
- AC POWER CORD

Disassembly Instructions

1. Removal of Bracket Shield DAC

(1) After removal of the top cover, remove four screws marked "O" as shown in Figure 3 and 5.

1. ブラケットシールドDACの外し方

(1) 上カバーを外した後、4本のネジ (O印) を外します。
(3、5図参照)

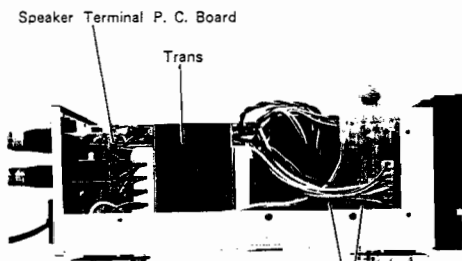

Figure 4
<4図>

2. Removal of Main P. C. Board

(1) After removal of Bracket Shield DAC remove eleven screws marked "x" as shown in Figure 3, 4, 5 and 6.

(2) Disconnect all wires from the Main P. C. Board and the P. C. Board with heatsink can be removed completely.

2. メイン基板の外し方

(1) ブラケット・シールドDACを外してから、11本のネジ (x印) を外します。(3、4、5、6図参照)

(2) メイン基板から出ている全てのワイヤーを外しますとヒートシンクと一緒にメイン基板を外すことができます。

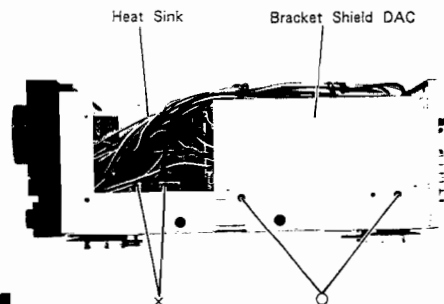

Figure 3
<3図>

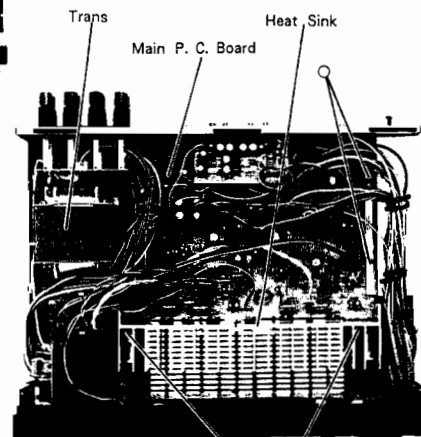

Figure 5
<5図>

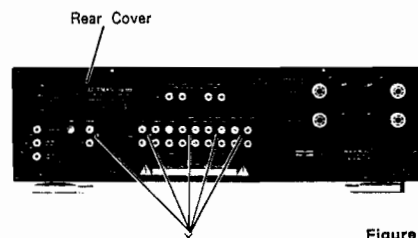

Figure 6
<6図>

Adjustment Procedures

1. Connections

1. 接続図

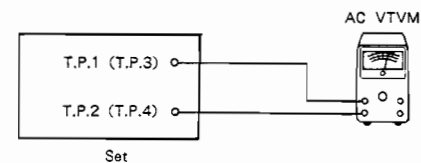

Figure 7
<7図>

2. Control Setting

Power Switch ON
Speaker Switch A Position
Others OFF

Volume Control Maximum
Treble/Bass/Balance Control Center

2. スイッチ類のセット位置

電源スイッチ ON
スピーカー・スイッチ A位置
その他のスイッチ OFF

音量調整 最大
トレブル/バス/バランス調整 中央

3. Adjustment Procedures

(1) Idling Adjustment (Figure 7. Connections)

1. Set VR7101 (VR7102) to center. (⊖)
2. Adjust VR7101 (VR7102) so that voltage between T.P.1 (T.P.3) and T.P.2 (T.P.4) reaches $5 \pm 30\text{mV}$.

Note: Proceed the adjustment shown above about a minute after power is turned on.

3. 調整方法

(1) アイドリング調整 (7図接続図参照)

1. VR7101 (VR7102) を中央にセットする。(⊖)
2. VR7101 (VR7102) を調整して、T.P.1 (T.P.3) と T.P.2 (T.P.4) 間の電圧が $5 \pm 30\text{mV}$ になるようにする。

注意: 電源を入れて約1分経ってから上記の調整を行います。

Adjustment Locations

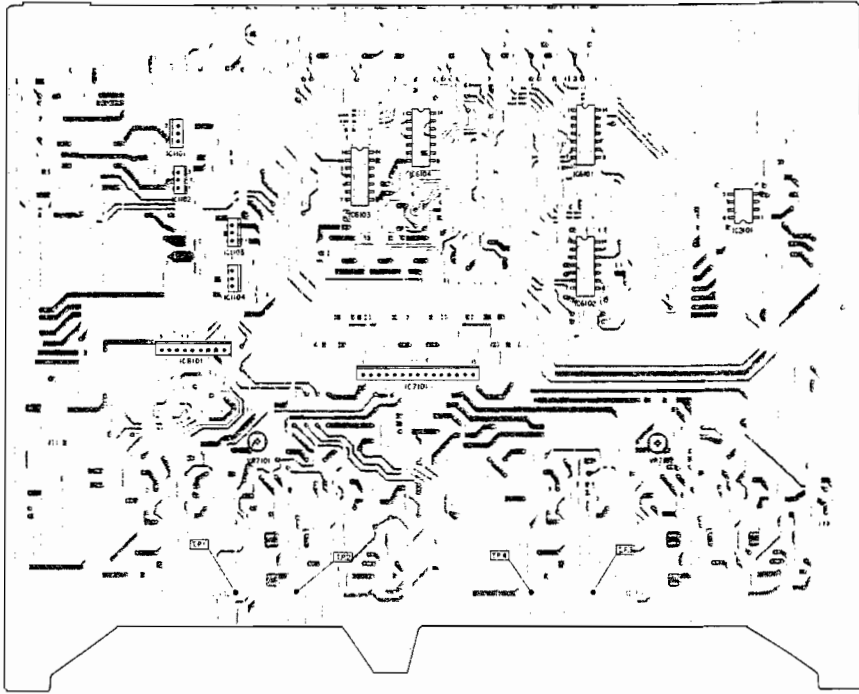

Block Diagram

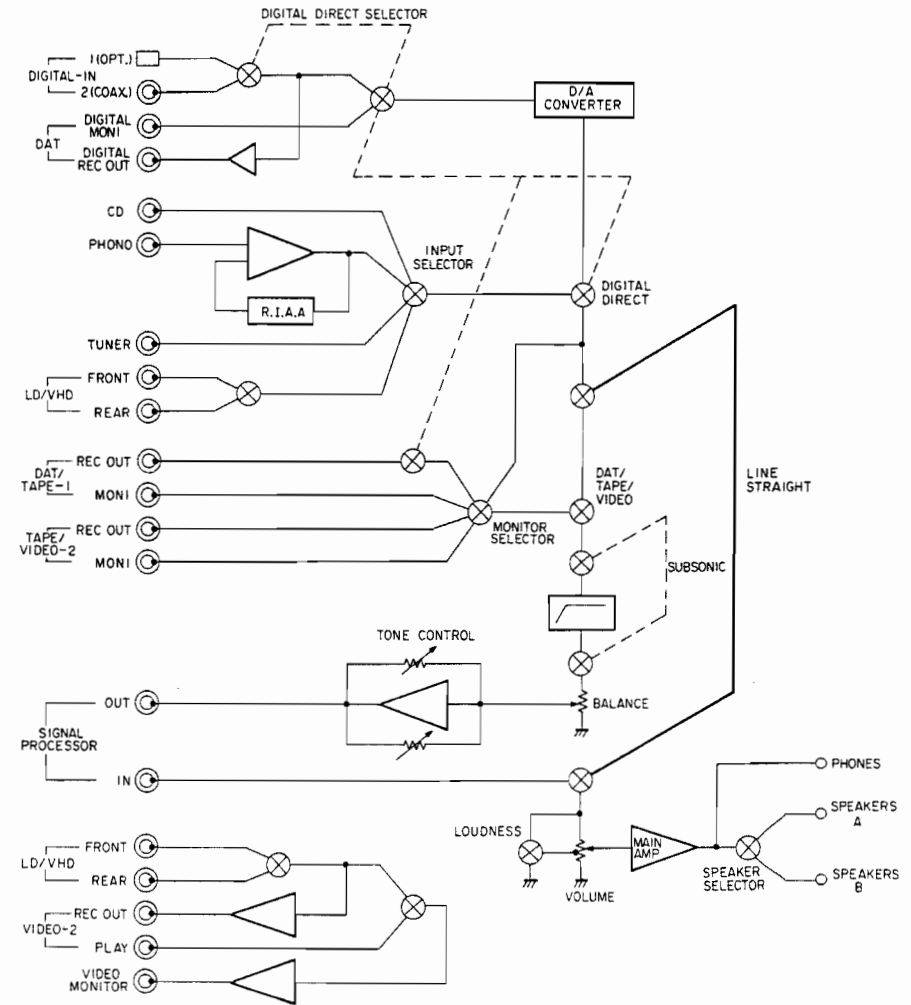

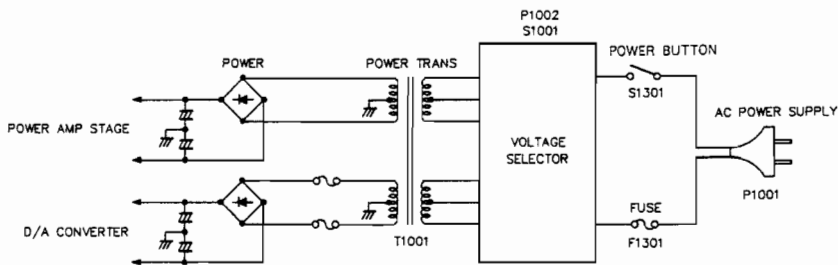

AD model only

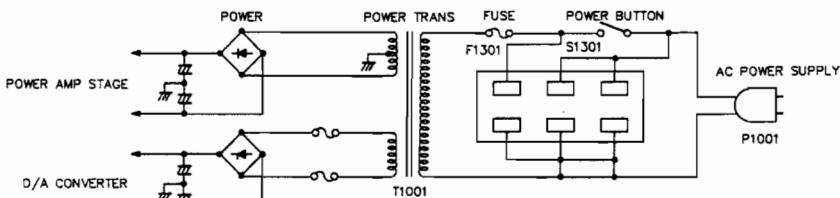

JA, UZ, UQ model

Parts Layout on P.C. Boards and Wiring Diagram (1/2)

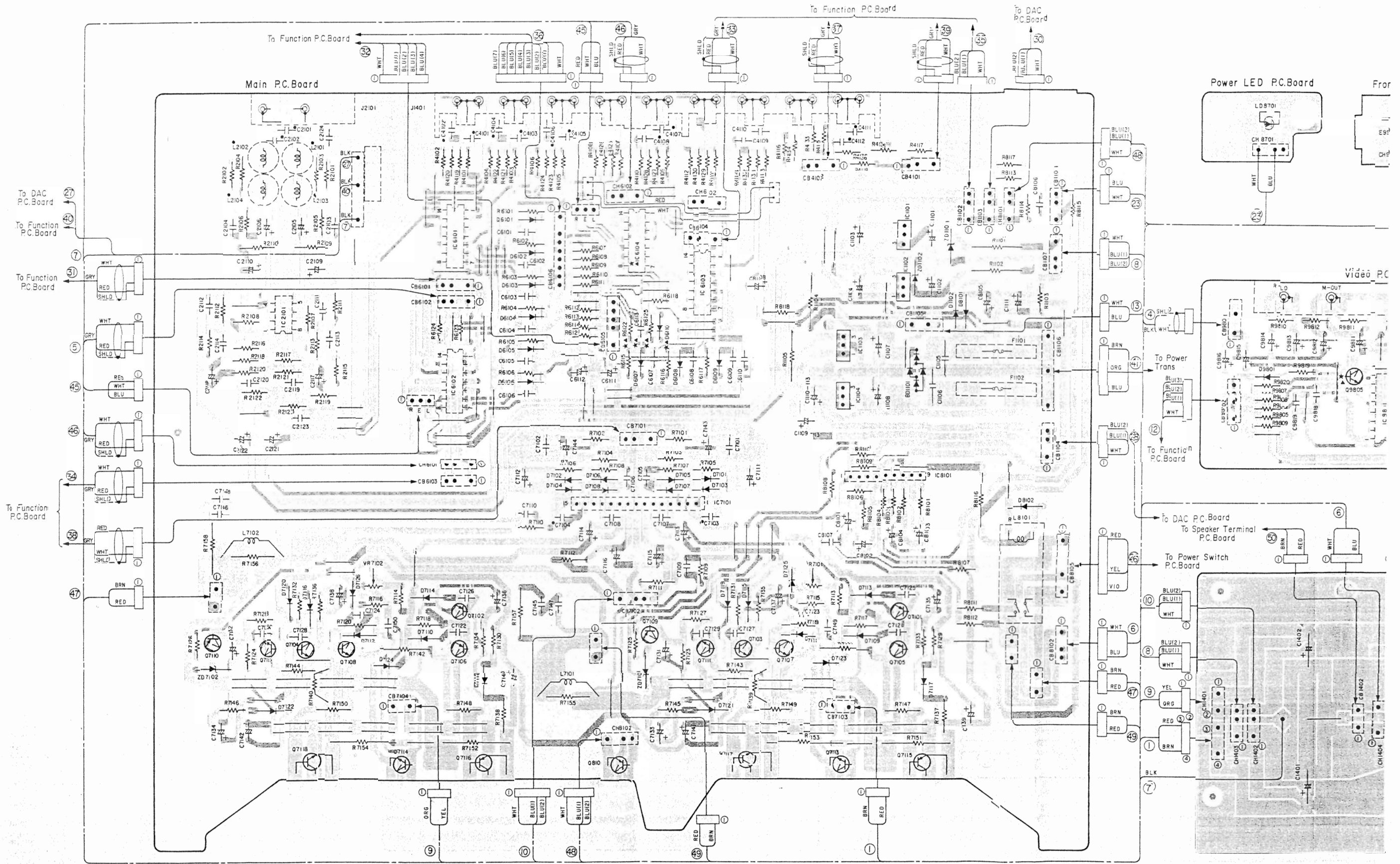

2)

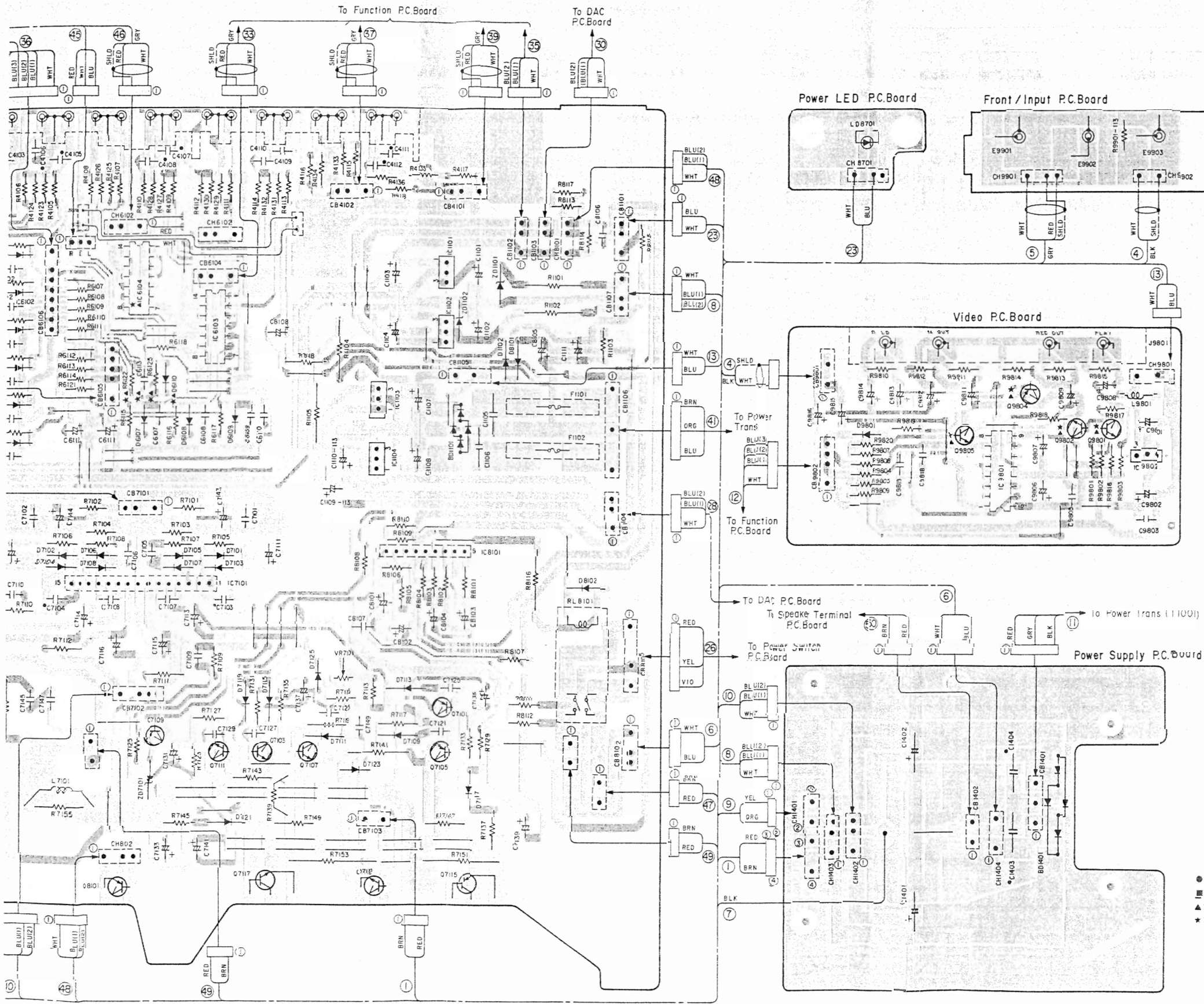

- AD Model Only.
- JA Model Only.
- ▲ UZ Model Only.
- ★ UQ Model Only.

- BLU Blue
- GRN Green
- BLK Black
- GRY Gray
- WHT White
- RED Red
- BRN Brown
- ORG Orange
- YEL Yellow
- PNK Pink
- VIO Violet
- GRN/WHT Green/White
- GRY/WHT Gray/White
- GRY/YEL Gray/Yellow
- GRN/YEL Green/Yellow
- SHL) Shield

Parts Layout on P.C. Boards and Wiring Diagram (2/2)

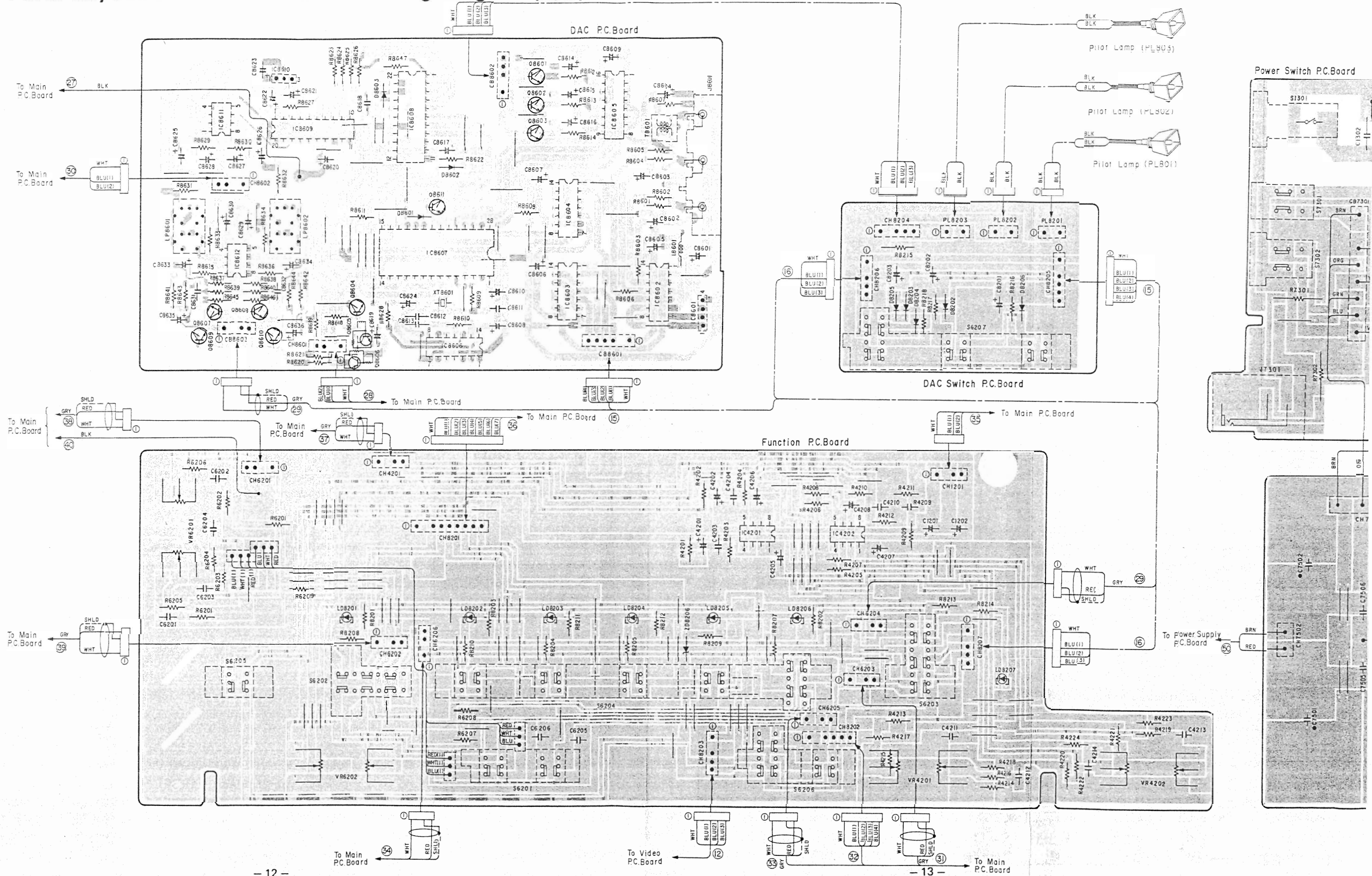

2/2)

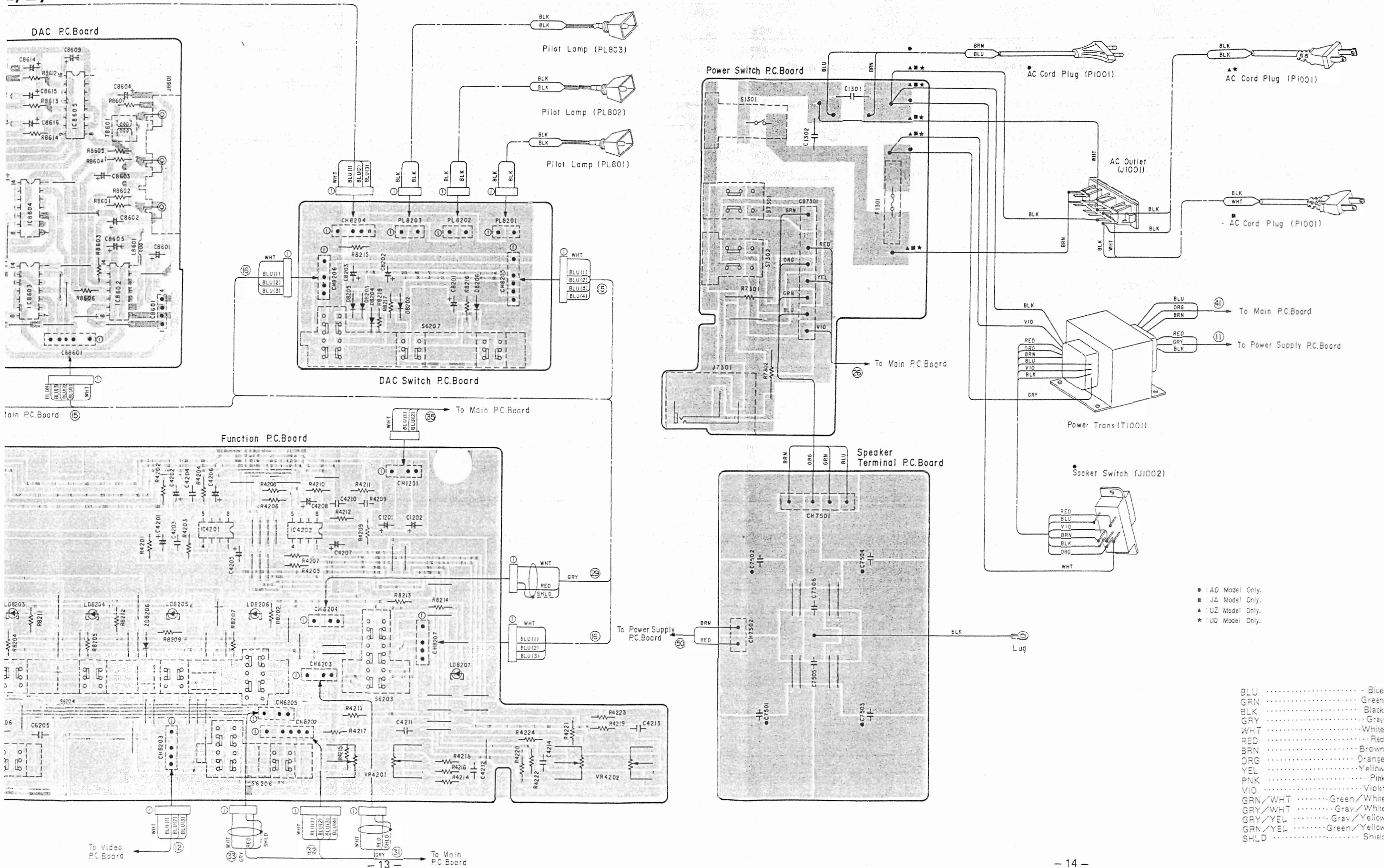

Schematic Diagram (1/2)

IC	IC2101 IC6101 IC6103	IC6102 IC6104 IC6105 IC1102	IC1701 IC8101	IC1104 IC1103	Q7110 Q7109	Q7104 Q7103 Q7101	Q7112 Q7111 Q7108 Q7107 Q7105	Q7118 Q7114 Q7106 Q8101 Q7117 Q7115
Transistor (Q)								

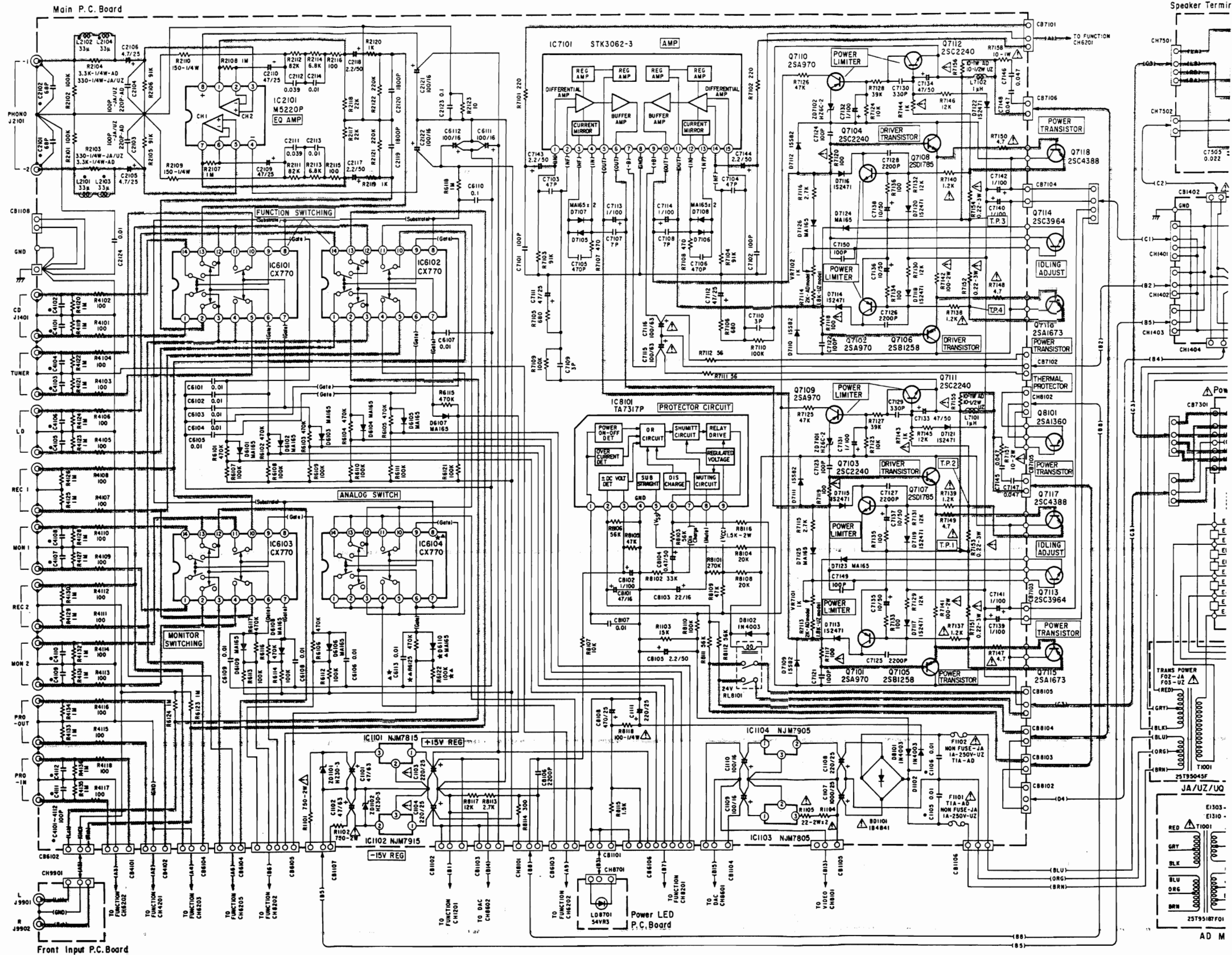

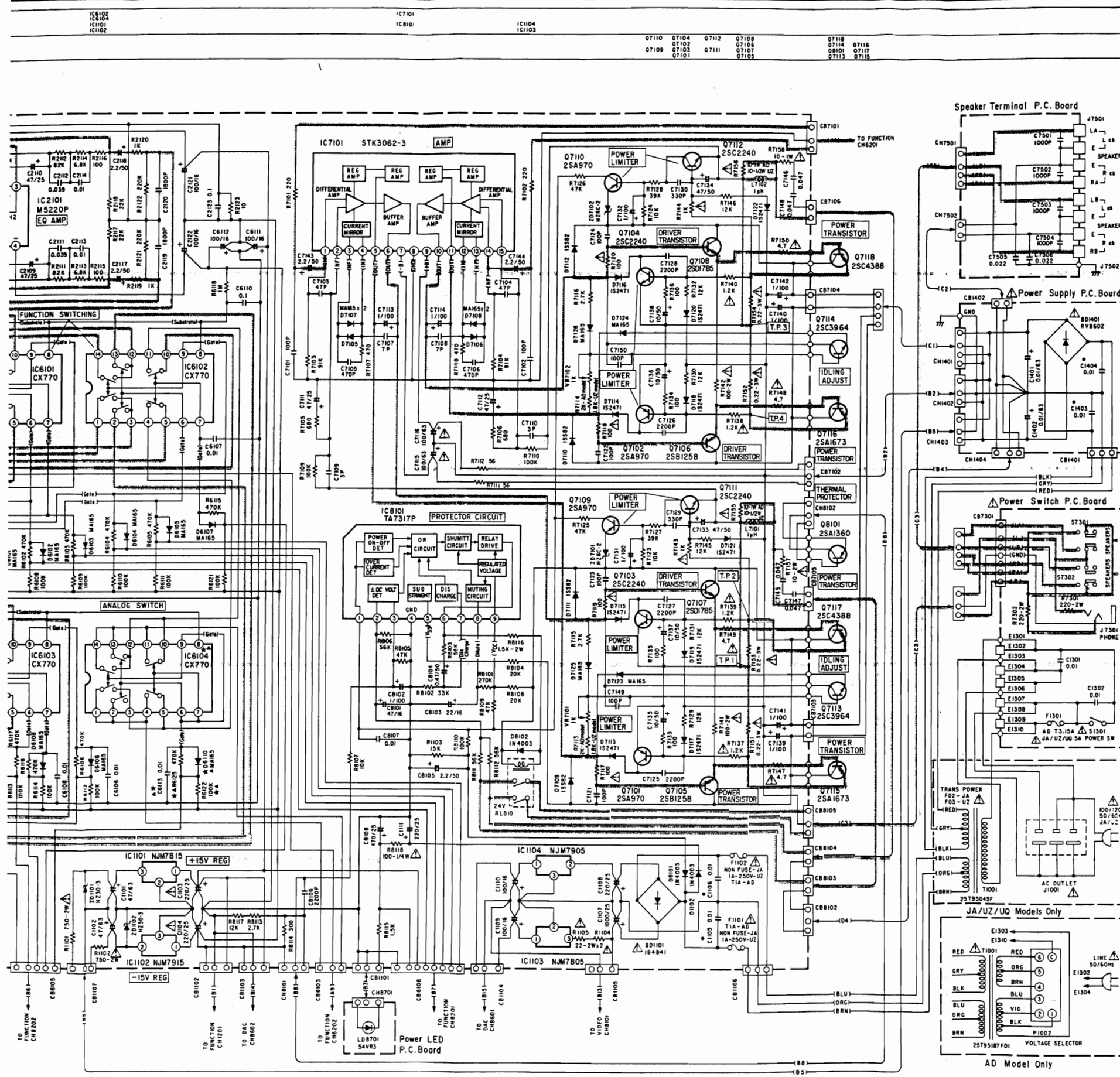

	E	C	B
Q7101	0V	-1.4V	0V
Q7102	0V	-1.4V	0V
Q7103	0V	1.4V	0V
Q7104	0V	1.4V	0V
Q7105	-0.8V	-51V	-1.5V
Q7106	-0.8V	-51V	-1.5V
Q7107	0.8V	-51V	-1.5V
Q7108	0.8V	-51V	-1.5V
Q7109	45V	-0.8V	48V
Q7110	4.5V	0.8V	48V
Q7111	0V	48V	0V
Q7112	0V	48V	0V
Q7113	-0.8V	1.5V	-0.8V
Q7114	-0.8V	1.5V	-0.8V
Q7115	0V	-51V	0V
Q7116	0V	-51V	0V
Q7117	0V	-51V	0V
Q7118	0V	-51V	0V
Q8101	15V	7.1V	14.8V

IC101	IC6104
1	1 0V
2	2 0V
3	3 0V
4	4 0V

IC102	IC6104
1	1 -15V
2	2 -51V
3	3 0V

IC103	IC6104
1	1 0V
2	2 0V
3	3 28V

IC104	IC6104
1	1 0V
2	2 -20V
3	3 0V

IC105	IC6104
1	1 4V
2	2 0V
3	3 0V
4	4 4V
5	5 0V
6	6 1.5V
7	7 -50V
8	8 0V
9	9 50V
10	10 1.5V
11	11 -1.5V
12	12 4V
13	13 4V
14	14 0V
15	15 0V

IC106	IC6104
1	1 0V
2	2 0V
3	3 0V
4	4 0V
5	5 0V
6	6 -15V
7	7 -15V
8	8 -15V
9	9 -15V
10	10 0V
11	11 0V
12	12 0V
13	13 0V
14	14 0V
15	15 0V

IC107	IC6104
1	1 0V
2	2 0V
3	3 0V
4	4 0V
5	5 0V
6	6 -15V
7	7 -15V
8	8 -15V
9	9 -15V
10	10 0V
11	11 0V
12	12 0V
13	13 0V
14	14 0V
15	15 0V

IC108	IC6104
1	1 -0.8V
2	2 0V
3	3 0V
4	4 0V
5	5 0V
6	6 -15V
7	7 1.5V
8	8 0.8V
9	9 -15V
10	10 0V
11	11 0V
12	12 0V
13	13 0V
14	14 0V
15	15 0V

IC109	IC6104
1	1 0V
2	2 0V
3	3 0V
4	4 0V
5	5 0V
6	6 -15V
7	7 -15V
8	8 -15V
9	9 -15V
10	10 0V
11	11 0V
12	12 0V
13	13 0V
14	14 0V
15	15 0V

IC110	IC6104
1	1 0V
2	2 0V
3	3 0V
4	4 0V
5	5 0V
6	6 -15V
7	7 -15V
8	8 -15V
9	9 -15V
10	10 0V
11	11 0V
12	12 0V
13	13 0V
14	14 0V
15	15 0V

IC111	IC6104
1	1 0V
2	2 0V
3	3 0V
4	4 0V
5	5 0V
6	6 -15V
7	7 -15V
8	8 -15V
9	9 -15V
10	10 0V
11	11 0V
12	12 0V
13	13 0V
14	14 0V
15	15 0V

IC112	IC6104
1	1 0V
2	2 0V
3	3 0V
4	4 0V
5	5 0V
6	6 -15V
7	7 -15V
8	8 -15V
9	9 -15V
10	10 0V
11	11 0V
12	12 0V
13	13 0V
14	14 0V
15	15 0V

IC113	IC6104
1	1 0V
2	2 0V
3	3 0V
4	4 0V
5	5 0V
6	6 -15V
7	7 -15V
8	8 -15V
9	9 -15V
10	10 0V
11	11 0V
12	12 0V
13	13 0V
14	14 0V
15	15 0V

IC114	IC6104
1	1 0V
2	2 0V
3	3 0V
4	4 0V
5	5 0V
6	6 -15V
7	7 -15V
8	8 -15V
9	9 -15V
10	10 0V
11	11 0V
12	12 0V
13	13 0V
14	14 0V
15	15 0V

IC115	IC6104
1	1 0V
2	2 0V
3	3 0V
4	4 0V
5	5 0V
6	6 -15V
7	7 -15V
8	8 -15V
9	9 -15V
10	10 0V
11	11 0V
12	12 0V
13	13 0V
14	14 0V
15	15 0V

IC116	IC6104
1	1 0V
2	2 0V
3	3 0V
4	4 0V
5	5 0V
6	6 -15V
7	7 -15V
8	8 -15V
9	9 -15V
10	10 0V
11	11 0V
12	12 0V
13	13 0V
14	14 0V
15	15 0V

IC117	IC6104
1	1 0V
2	2 0V
3	3 0V
4	4 0V
5	5 0V
6	6 -15V
7	7 -15V
8	8 -15V
9	9 -15V
10	10 0V
11	11 0V
12	12 0V
13	13 0V
14	14 0V
15	15 0V

IC118	IC6104
1	1 0V
2	2 0V
3	3 0V
4	4 0V
5	5 0V
6	6 -15V
7	7 -15V
8	8 -15V
9	9 -15V
10	10 0V
11	11 0V
12	12 0V
13	13 0V
14	14 0V
15	15 0V

IC119	IC6104
1	1 0V
2	2 0V
3	3 0V
4	4 0V
5	5 0V
6	6 -15V
7	7 -15V
8	8 -15V
9	9 -15V
10	10 0V
11	11 0V
12	12 0V
13	13 0V
14	14 0V
15	15 0V

IC120	IC6104
1	1 0V
2	2 0V
3	3 0V
4	4 0V
5	5 0V
6	6 -15V
7	7 -15V
8	8 -15V
9	9 -15V
10	10 0V
11	11 0V
12	12 0V
13	13 0V
14	14 0V
15	15 0V

CAUTION:
The Δ marks in the schematic diagram designate components which have special characteristics important for safety and should be replaced only with types identical to those in the original circuit or specified in the parts list.

- NOTES:
- All resistance values are in ohms. K = 1,000
 - All capacitance values are in microfarads. P = $\frac{1}{1,000,000}$

LV-113

Schematic Diagram (2/2)

IC	IC8601	IC8604	IC8602 IC8603	IC8606	IC8605	IC8607	IC8601	IC8612	IC8609 IC8608	IC8611	IC8610	IC4202	IC4201
Transistor (Q)			Q8601 Q8601	Q8602 Q8602	Q8603 Q8604	Q8605	Q8606	Q8604	Q8611		Q8607 Q8608	Q8609 Q8610	

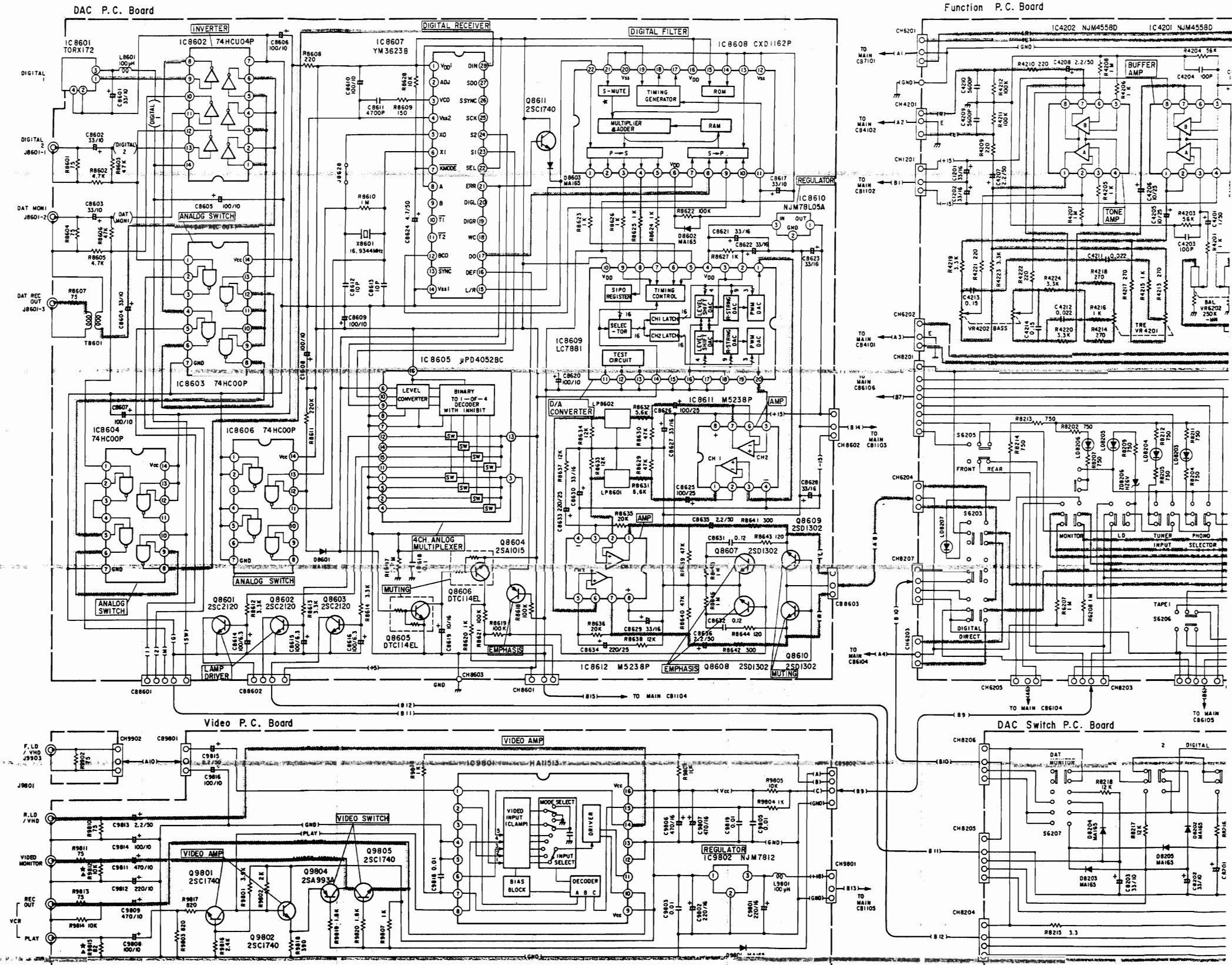

- NOTES:
1. All resistance values are in ohms, K = 1,000
 2. All capacitance values are in microfarads, P = 1,000,000

LV-113

IC8602	IC8606	IC8605	IC8607	IC8601	IC8612	IC8609	IC8611	IC8610	IC4202	IC4201
Q8601	Q8602	Q8603	Q8605	Q8606	Q8604	Q8611	Q8607	Q8609	Q8608	Q8610

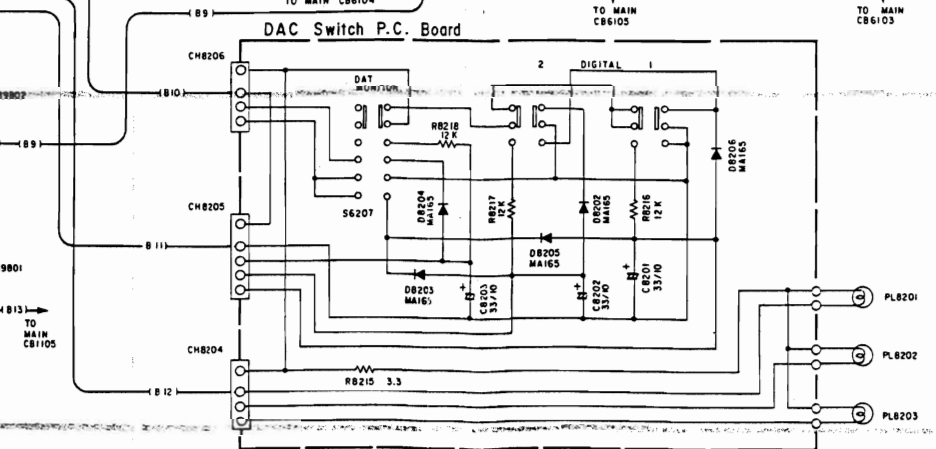
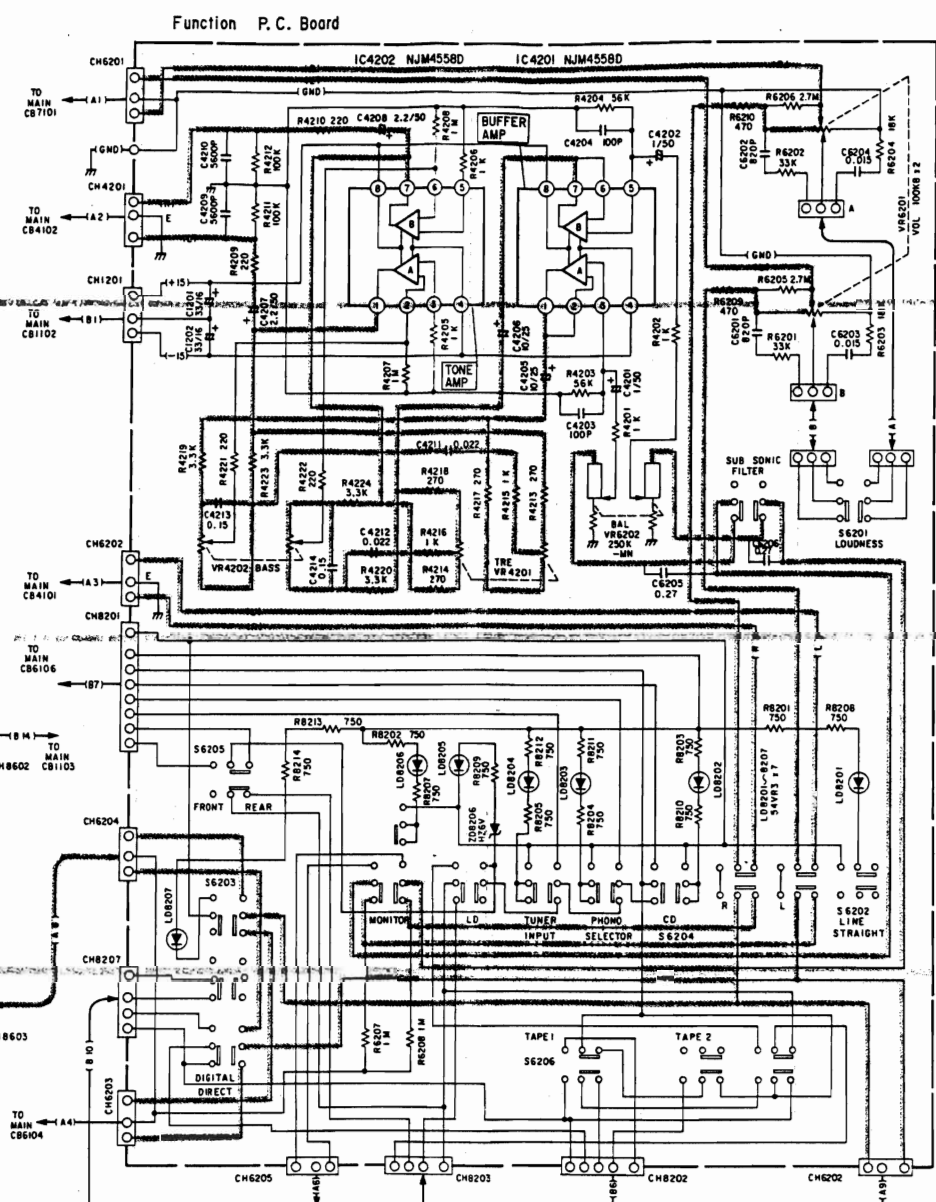
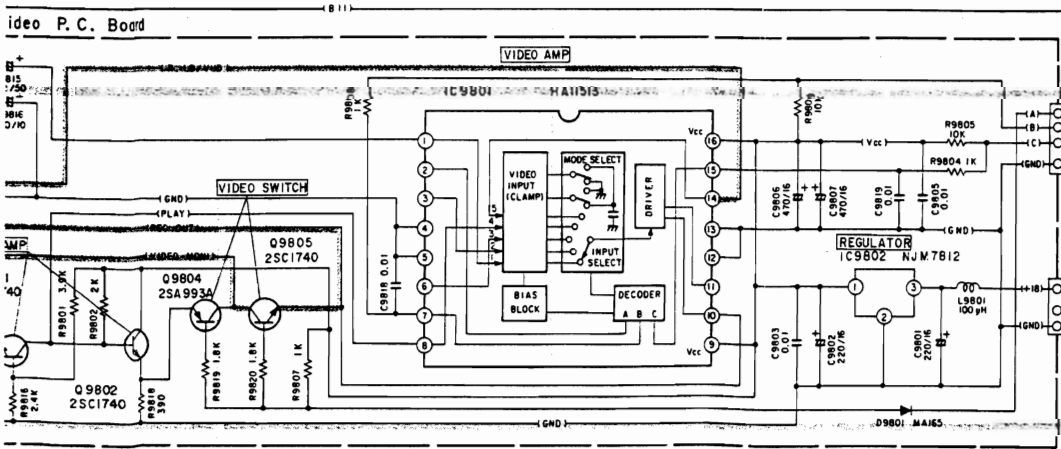
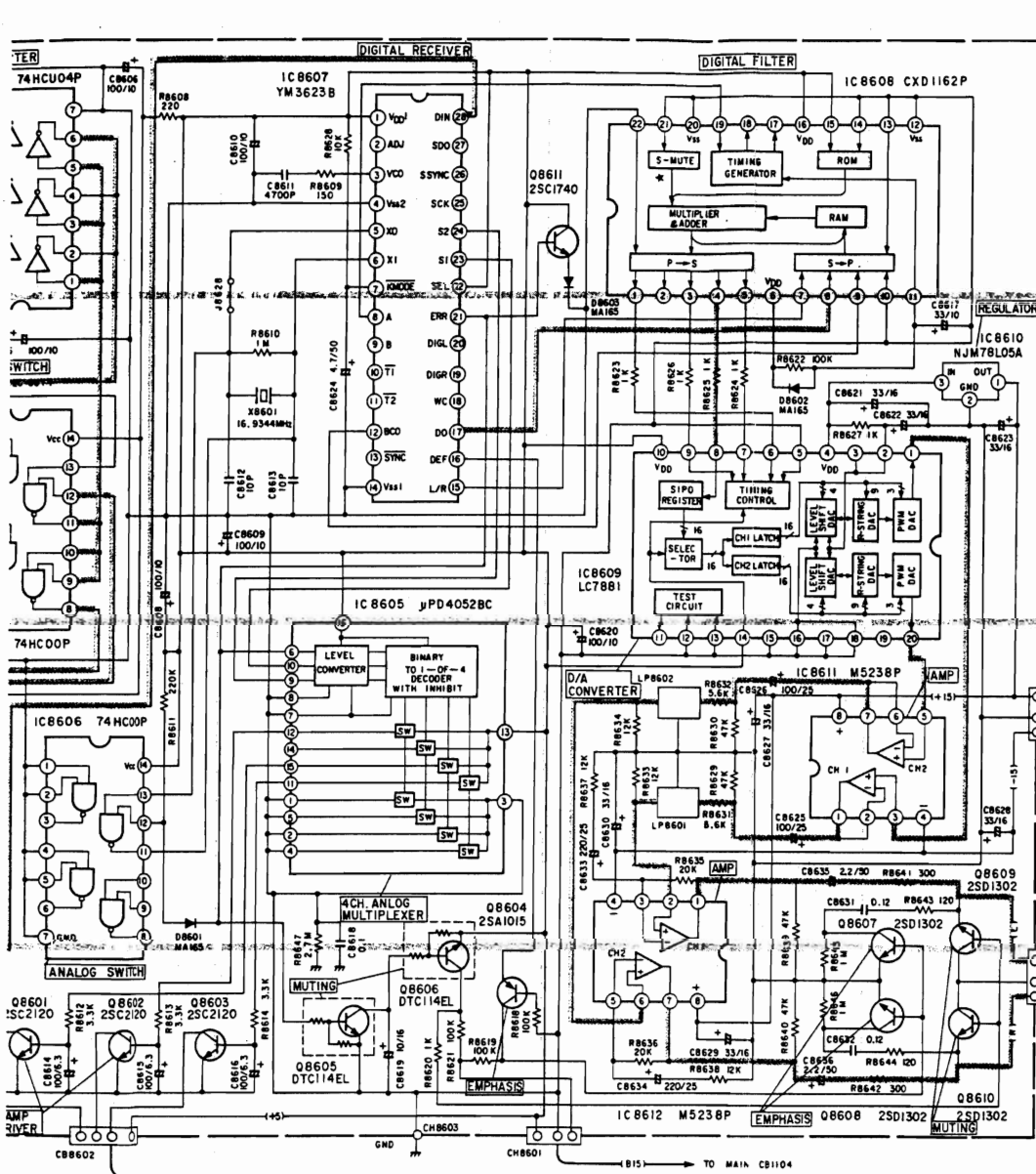

Pin	V	C	B
Q8601	0V	5V	0V
Q8602	0V	5V	0V
Q8603	0V	5V	0V
Q8604	0V	-5V	0V
Q8605	0V	0V	4.4V
Q8606	5V	5V	0V
Q8607	0V	0V	-4V
Q8608	0V	0V	-4V
Q8609	0V	0V	0.7V
Q8610	-5V	0V	0.7V
Q8611	3.0V	7.1V	4.5V
Q8612	6.5V	12V	7.1V
Q8613	6.1V	0.1V	6.1V
Q8614	0V	0.1V	0V

Pin	V
IC4202	1 0V
	2 0V
	3 0V
	4 -15V
	5 0V
	6 0V
	7 5V
	8 15V

Pin	V
IC8604	1 0V
	2 0V
	3 5V
	4 5V
	5 5V
	6 0V
	7 5V
	8 1.7V
	9 2.4V
	10 0V
	11 5V
	12 4.1V

Pin	V
IC8605	1 0V
	2 0V
	3 0V
	4 5V
	5 0V
	6 2.5V
	7 2.5V
	8 0V
	9 4.5V
	10 0V
	11 0V
	12 1.8V
	13 1.8V
	14 15V

Pin	V
IC8606	1 0V
	2 0V
	3 0V
	4 0V
	5 0V
	6 5V
	7 0V
	8 0V
	9 5V
	10 5V
	11 5V
	12 5V
	13 5V
	14 5V

Pin	V
IC8607	1 0V
	2 0V
	3 0V
	4 0V
	5 0V
	6 0V
	7 0V
	8 0V
	9 0V
	10 0V
	11 0V
	12 0V
	13 0V
	14 0V

Pin	V
IC8608	1 0V
	2 0V
	3 0V
	4 0V
	5 0V
	6 0V
	7 0V
	8 0V
	9 0V
	10 0V
	11 0V
	12 0V
	13 0V
	14 0V

[Measuring Conditions]
 - Power Supply Voltage : JA AC100V
 : UQ/UZ AC120V
 : AD AC120/220/240V
 - Measuring Meter : Digital Multi Voltmeter
 - Measuring Point Reference : Between Ground
 - Measuring Condition : No Signal Input

Electrical Parts List

Resistor : Carbon resistors under 1/4 watts are not mentioned in the parts list, please confirm them by schematic diagram.
 uF= microfarads, pF= picofarads

Abbreviations				Symbol No.	Part No.	Description		
RES. = Resistor	CAP. = Capacitor			D6105	48T44813F01	MA165TA		
C.F. = Carbon Film	ELY. = Electrolytic			D6106	48T44813F01	MA165TA		
M.F. = Metal Film	CER. = Ceramic			D6107	48T44813F01	MA165TA		
M.O. = Metal Oxide Film	MYL. = Mylar			D6108	48T44813F01	MA165TA		
M.P. = Metal Plate	TAN. = Tantalum			D6109	48T44813F01	MA165TA		
TR. = Transistor	POLY. = Polystyrol			▲ D6110	48T44813F02	MA165TA		
TRANS. = Transformer	PP. = Polypropylene			D7105	48T44813F01	MA165TA		
CP. = Chip	PLT. = Polyethylene			D7106	48T44813F01	MA165TA		
				D7107	48T44813F01	MA165TA		
				D7108	48T44813F01	MA165TA		
Main P. C. Board								
IC's								
IC1101	51T82394F01	NJM7815FA						
IC1102	51T82395F01	NJM7915FA						
IC1103	51T80338F01	NJM7805 MOLD						
IC1104	51T80339F01	NJM7905 MOLD						
IC2101	51T00038L01	M5220P						
IC6101	51T80854F01	CX-770						
IC6102	51T80854F01	CX-770						
IC6103	51T80854F01	CX-770						
▲ IC6104	51T80854F01	CX-770						
IC7101	51T68833F01	STK3062 MARK3						
IC8101	51T67437F01	TA7317P						
Transistors								
Q7101	48T52545F03	2SA970						
Q7102	48T52545F03	2SA970						
Q7103	48T53301F02	2SC2240						
Q7104	48T53301F02	2SC2240						
Q7105	48T94820F01	2SB1258						
Q7106	48T94820F01	2SB1258						
Q7107	48T94821F01	2SD1785						
Q7108	48T94821F01	2SD1785						
Q7109	48T52545F03	2SA970						
Q7110	48T52545F03	2SA970						
Q7111	48T53301F02	2SC2240						
Q7112	48T53301F02	2SC2240						
Diodes								
D1102	48T44813F01	MA165TA						
D6101	48T44813F01	MA165TA						
D6102	48T44813F01	MA165TA						
D6103	48T44813F01	MA165TA						
D6104	48T44813F01	MA165TA						
Coils								
● L2101	24T83130F02	Inductor, 33 μ H						
● L2102	24T83130F02	Inductor, 33 μ H						
● L2103	24T83130F02	Inductor, 33 μ H						
● L2104	24T83130F02	Inductor, 33 μ H						
L7101	24T74372F02	Inductor, 1 μ H						
L7102	24T74372F02	Inductor, 1 μ H						
		VERTI						
		VERTI						

Notes : ● : For West German model only (AD), ▲ : For North American model only (UZ),
 ■ : For Japanese model only (JA), ★ : For Canadian model only (UQ), Others : Common.

Symbol No.	Part No.	Description	Symbol No.	Part No.	Description
Relay/Jacks					
RL8101	80T9509F02	Relay, DH24D2-OT (M)	C2112	08T93406F63	PP., 0.039 μ F
J2101	09T72805F01	Plate, PH (2P)	C2113	08T93406F49	PP., 0.01 μ F
J4101	09T72806F02	Plate, PH (18P)	C2114	08T93406F49	PP., 0.01 μ F
Capacitors					
▲ C1101	23T00138L62	ELY., 47 μ F/63V	▲ C2120	08T93406F31	PP., 1800pF
■ C1101	23T00138L62	ELY., 47 μ F/63V	▲ C2121	23T00138L21	ELY., 100 μ F/16V
● C1101	23T00149L68	ELY., 47 μ F/63V	■ C2121	23T00138L21	ELY., 100 μ F/16V
▲ C1102	23T00138L62	ELY., 47 μ F/63V	● C2121	23T00149L25	ELY., 100 μ F/16V
■ C1102	23T00138L62	ELY., 47 μ F/63V	▲ C2122	23T00138L21	ELY., 100 μ F/16V
● C1102	23T00149L68	ELY., 47 μ F/63V	■ C2122	23T00138L21	ELY., 100 μ F/16V
▲ C1103	23T00138L32	ELY., 220 μ F/25V	● C2122	23T00149L25	ELY., 100 μ F/16V
■ C1103	23T00138L32	ELY., 220 μ F/25V	▲ C2123	08T57298F01	CER., 0.1 μ F
● C1103	23T00149L37	ELY., 220 μ F/25V	C2124	08T57298F01	CER., 0.1 μ F
▲ C1104	23T00138L32	ELY., 220 μ F/25V	● C4101	08S40805F01	CER., 100pF
■ C1104	23T00138L32	ELY., 220 μ F/25V	● C4102	08S40805F01	CER., 100pF
● C1104	23T00149L37	ELY., 220 μ F/25V	● C4103	08S40805F01	CER., 100pF
▲ C1105	21T68834F01	CER., 0.01 μ F	● C4104	08S40805F01	CER., 100pF
■ C1105	21T68834F01	CER., 0.01 μ F	● C4105	08S40805F01	CER., 100pF
● C1105	21T68834F01	CER., 0.01 μ F	● C4106	08S40805F01	CER., 100pF
▲ C1107	23T00134L46	ELY., 1000 μ F/25V	● C4107	08S40805F01	CER., 100pF
■ C1108	23T00138L32	ELY., 220 μ F/25V	● C4108	08S40805F01	CER., 100pF
● C1108	23T00138L32	ELY., 220 μ F/25V	● C4109	08S40805F01	CER., 100pF
▲ C1108	23T00149L37	ELY., 220 μ F/25V	● C4110	08S40805F01	CER., 100pF
■ C1109	23T00138L21	ELY., 100 μ F/16V	● C4111	08S40805F01	CER., 100pF
● C1109	23T00138L21	ELY., 100 μ F/16V	● C4112	08S40805F01	CER., 100pF
▲ C1109	23T00149L25	ELY., 100 μ F/16V	C6101	08T52714F13	CER., 0.01 μ F
■ C1110	23T00138L21	ELY., 100 μ F/16V	C6102	08T52714F13	CER., 0.01 μ F
● C1110	23T00138L21	ELY., 100 μ F/16V	C6103	08T52714F13	CER., 0.01 μ F
▲ C1110	23T00149L25	ELY., 100 μ F/16V	C6104	08T52714F13	CER., 0.01 μ F
■ C1111	23T00138L32	ELY., 220 μ F/25V	C6105	08T52714F13	CER., 0.01 μ F
● C1111	23T00149L37	ELY., 220 μ F/25V	C6106	08T52714F13	CER., 0.01 μ F
▲ C2101	21S40655F35	CER., 68pF	C6107	08T52714F13	CER., 0.01 μ F
■ C2102	21S40655F35	CER., 68pF	C6109	08T52714F13	CER., 0.01 μ F
● C2103	08S40805F01	CER., 100pF	C6110	08T57298F01	CER., 0.1 μ F
▲ C2103	08S40805F01	CER., 100pF	▲ C6111	23T00138L21	ELY., 100 μ F/16V
■ C2103	08S40805F01	CER., 100pF	■ C6111	23T00138L21	ELY., 100 μ F/16V
● C2104	08S40805F01	CER., 100pF	● C6111	23T00149L25	ELY., 100 μ F/16V
▲ C2104	08S40805F01	CER., 100pF	▲ C6112	23T00138L21	ELY., 100 μ F/16V
■ C2104	08S40805F03	CER., 220pF	■ C6112	23T00138L21	ELY., 100 μ F/16V
● C2105	23T90772F40	ELY., 4.7 μ F/25V	▲ C6112	23T00149L25	ELY., 100 μ F/16V
▲ C2106	23T90772F40	ELY., 4.7 μ F/25V	■ C6113	08T44979P22	CER., 0.01 μ F
■ C2109	23T42478F31	ELY., 47 μ F/25V	C7101	08S40805F01	CER., 100pF
● C2110	23T42478F31	ELY., 47 μ F/25V	C7102	08S40805F01	CER., 100pF
▲ C2111	08T93406F63	PP., 0.039 μ F			

Notes: ●: For West German model only (AD), ▲: For North American model only (UZ),
 ■: For Japanese model only (JA), ★: For Canadian model only (UQ), Others: Common.

Symbol No.	Part No.	Description	Symbol No.	Part No.	Description
● C7103	08T61939F27	CER., 47pF	▲ C7137	23T00138L49	ELY., 10 μ F/50V
● C7104	08T61939F27	CER., 47pF	■ C7137	23T00138L49	ELY., 10 μ F/50V
C7105	08S40805F05	CER., 470pF	● C7137	23T00149L58	ELY., 10 μ F/50V
C7106	08S40805F05	CER., 470pF	▲ C7138	23T00138L49	ELY., 10 μ F/50V
C7107	08T81196F05	MIC., 7pF	■ C7138	23T00138L49	ELY., 10 μ F/50V
C7108	08T81196F05	MIC., 7pF	● C7138	23T00149L56	ELY., 10 μ F/50V
C7109	08T81196F03	MIC., 3pF	▲ C7139	23T00138L72	ELY., 1 μ F/100V
C7110	08T81196F03	MIC., 3pF	● C7139	23T00149L74	ELY., 1 μ F/100V
C7111	23T73856F13	ELY., 47 μ F/25V	■ C7139	23T00138L72	ELY., 1 μ F/100V
C7112	23T73856F13	ELY., 47 μ F/25V	▲ C7140	23T00138L72	ELY., 1 μ F/100V
▲ C7113	23T00138L72	ELY., 1 μ F/100V	● C7140	23T00149L74	ELY., 1 μ F/100V
● C7113	23T00149L74	ELY., 1 μ F/100V	■ C7140	23T00138L72	ELY., 1 μ F/100V
■ C7113	23T00138L72	ELY., 1 μ F/100V	▲ C7141	23T00138L72	ELY., 1 μ F/100V
▲ C7114	23T00138L72	ELY., 1 μ F/100V	● C7141	23T00149L74	ELY., 1 μ F/100V
● C7114	23T00149L74	ELY., 1 μ F/100V	■ C7141	23T00138L72	ELY., 1 μ F/100V
■ C7114	23T00138L72	ELY., 1 μ F/100V	▲ C7142	23T00138L72	ELY., 1 μ F/100V
▲ C7115	23T00138L63	ELY., 100 μ F/63V	● C7142	23T00149L74	ELY., 1 μ F/100V
■ C7115	23T00138L63	ELY., 100 μ F/63V	■ C7142	23T00138L72	ELY., 1 μ F/100V
● C7115	23T00149L69	ELY., 100 μ F/63V	▲ C7143	23T00149L46	ELY., 2.2 μ F/50V
▲ C7116	23T00138L63	ELY., 100 μ F/63V	● C7143	23T00149L53	ELY., 2.2 μ F/50V
■ C7116	23T00138L63	ELY., 100 μ F/63V	▲ C7143	23T00149L53	ELY., 2.2 μ F/50V
● C7118	23T00138L63	ELY., 100 μ F/63V	■ C7143	23T00149L53	ELY., 2.2 μ F/50V
● C7118	23T00149L69	ELY., 100 μ F/63V	▲ C7143	23T00149L53	ELY., 2.2 μ F/50V
C7121	08T81196F34	MIC., 100pF	■ C7143	23T00149L53	ELY., 2.2 μ F/50V
C7122	08T81196F34	MIC., 100pF	▲ C7144	23T90772F70	ELY., 2.2 μ F/50V
C7123	08T81196F34	MIC., 100pF	■ C7144	23T00149L46	ELY., 2.2 μ F/50V
C7124	08T81196F34	MIC., 100pF	● C7144	23T00149L53	ELY., 2.2 μ F/50V
C7125	08T93406F33	PP., 2200pF	▲ C7144	23T90772F70	ELY., 2.2 μ F/50V
C7126	08T93406F33	PP., 2200pF	C7145	08T40658F70	CER., 0.047 μ F
C7127	08T93406F33	PP., 2200pF	▲ C7145	08T40658F70	CER., 0.047 μ F
C7128	08T93406F33	PP., 2200pF	■ C7145	08T40658F70	CER., 0.047 μ F
C7129	08T93406F13	PP., 330pF	C7146	08T40658F70	CER., 0.047 μ F
C7130	08T93406F13	PP., 330pF	C7147	08T40658F70	CER., 0.047 μ F
▲ C7131	23T00138L72	ELY., 1 μ F/100V	C7148	08T40658F70	CER., 0.047 μ F
■ C7131	23T00149L74	ELY., 1 μ F/100V	C7149	08S40805F01	CER., 100pF
● C7131	23T00138L72	ELY., 1 μ F/100V	C7150	08S40805F01	CER., 100pF
▲ C7132	23T00138L72	ELY., 1 μ F/100V	▲ C8101	23T00138L20	ELY., 47 μ F/16V
● C7132	23T00149L74	ELY., 1 μ F/100V	■ C8101	23T00138L20	ELY., 47 μ F/16V
■ C7132	23T00138L72	ELY., 1 μ F/100V	● C8101	23T00149L23	ELY., 47 μ F/16V
▲ C7133	23T00138L52	ELY., 47 μ F/50V	▲ C8102	23T00138L72	ELY., 1 μ F/100V
■ C7133	23T00138L52	ELY., 47 μ F/50V	■ C8102	23T00149L74	ELY., 1 μ F/100V
● C7133	23T00149L59	ELY., 47 μ F/50V	▲ C8102	23T00138L72	ELY., 1 μ F/100V
▲ C7134	23T00138L52	ELY., 47 μ F/50V	■ C8102	23T00138L72	ELY., 1 μ F/100V
■ C7134	23T00138L52	ELY., 47 μ F/50V	▲ C8103	23T00138L18	ELY., 22 μ F/16V
● C7134	23T00149L59	ELY., 47 μ F/50V	■ C8103	23T00138L18	ELY., 22 μ F/16V
▲ C7135	23T00138L49	ELY., 10 μ F/50V	● C8103	23T00149L21	ELY., 22 μ F/16V
■ C7135	23T00138L49	ELY., 10 μ F/50V	▲ C8104	23T00138L44	ELY., 0.47 μ F/50V
● C7135	23T00149L56	ELY., 10 μ F/50V	■ C8104	23T00138L44	ELY., 0.47 μ F/50V
▲ C7136	23T00138L49	ELY., 10 μ F/50V	● C8104	23T00149L51	ELY., 0.47 μ F/50V
■ C7136	23T00138L49	ELY., 10 μ F/50V	■ C8105	23T00138L46	ELY., 2.2 μ F/50V
● C7136	23T00149L56	ELY., 10 μ F/50V	▲ C8105	23T00138L46	ELY., 2.2 μ F/50V
			● C8105	23T00149L53	ELY., 2.2 μ F/50V
			▲ C8106	08S40805F11	CER., 2200pF
			■ C8107	08T52714F13	CER., 0.01 μ F
			▲ C8108	23T00149L39	ELY., 470 μ F/25V

Notes: ●: For West German model only (AD), ▲: For North American model only (UZ),
 ■: For Japanese model only (JA), ★: For Canadian model only (UQ), Others: Common.

Symbol No.	Part No.	Description		
Resistors				
R1101	06T92264F46	M.F., 750 ohm 2W		
R1102	06T92264F46	M.F., 750 ohm 2W		
R1104	06T92264F09	M.F., 22 ohm 2W		
R1105	06T92264F09	M.F., 22 ohm 2W		
R7141	06T92264F25	M.F., 100 ohm 2W		
R7142	06T92264F25	M.F., 100 ohm 2W		
R7151	06T92262F01	M.F., 0.22 ohm 3W		
R7152	06T92262F01	M.F., 0.22 ohm 3W		
R7153	06T92262F01	M.F., 0.22 ohm 3W		
R7154	06T92262F01	M.F., 0.22 ohm 3W		
● R7155	06T92263F01	M.F., 10 ohm 1W		
■ R7155	06T92263F01	M.F., 10 ohm 1W		
▲ R7155	06C43205J37	M.F., 10 ohm 1/2W		
● R7156	06T92263F01	M.F., 10 ohm 1W		
■ R7156	06T92263F01	M.F., 10 ohm 1W		
▲ R7156	06C43205J37	M.F., 10 ohm 1/2W		
R7157	06T92264F01	M.F., 10 ohm 2W		
R7158	06T92264F01	M.F., 10 ohm 2W		
R8116	06T92264F53	M.F., 1.5k ohm 2W		
VR7101	18C41732G07	Variable 1k ohm		
VR7102	18C41732G07	Variable 1k ohm		
Power Switch P. C. Board				
Switches/Jack/Capacitors/Resistors				
S1301	40T92255F02	Switch, PUSH SDDL 1P (POWER)		
S7301	40T95032F01	Switch, PUSH SPUN19 (SPEAKERS A)		
S7302	40T95031F01	Switch, PUSH SPUN12 (SPEAKERS B)		
J7301	09T52845F12	Jack, HD M1658AYCA (PHONE)		
C1301	08T57437F09	CER., 0.01 μ F		
C1302	08T57437F09	CER., 0.01 μ F		
R7301	06T92264F33	M.F., 220 ohm		
R7302	06T92264F33	M.F., 220 ohm		
Power Supply P. C. Board				
Diode/Capacitors				
BD1401	48T81924F01	Bridge Diode, RBV-602		
C1401	23T95038F01	ELY., 0.01 μ F/53V		
● C1402	23T95038F01	ELY., 0.01 μ F/53V		
■ C1403	21T68834F01	CER., 0.01 μ F		
● C1404	21T68834F01	CER., 0.01 μ F		
Function P. C. Board				
IC's				
IC4201	51T52383F01	NJM4558D		
IC4202	51T52383F01	NJM4558D		
Diodes				
LD8201	48T66616F02	LED, SLR-54VR3 (RED)		
LD8202	48T66616F02	LED, SLR-54VR3 (RED)		
LD8203	48T66616F02	LED, SLR-54VR3 (RED)		
LD8204	48T66616F02	LED, SLR-54VR3 (RED)		
LD8205	48T66616F02	LED, SLR-54VR3 (RED)		
LD8206	48T66616F02	LED, SLR-54VR3 (RED)		
LD8207	48T66616F02	LED, SLR-54VR3 (RED)		
ZD8206	48T68697F27	Zener, HZS6.8EB2		
Capacitors				
C1201	23S57007F13	ELY., 33 μ F/16V		
C1202	23S57007F13	ELY., 33 μ F/16V		
C4201	23S57007F05	ELY., 1 μ F/50V		
C4202	23S57007F05	ELY., 1 μ F/50V		
C4203	08S40805F01	CER., 100pF		
C4204	08S40805F01	CER., 100pF		
C4205	23S57007F21	ELY., 10 μ F/25V		
● C4206	23S57007F21	ELY., 10 μ F/25V		
C4207	23S57007F06	ELY., 2.2 μ F/50V		
C4208	23S57007F06	ELY., 2.2 μ F/50V		

Notes: ● : For West German model only (AD), ▲ : For North American model only (UZ), ■ : For Japanese model only (JA), ★ : For Canadian model only (UQ), Others : Common.

Symbol No.	Part No.	Description		
C4209	08S40805F16	CER., 5600pF		
C4210	08S40805F16	CER., 5600pF		
C4211	08T57851F05	T.F., 0.022 μ F		
C4212	08T57851F05	T.F., 0.022 μ F		
C4213	08T57851F15	T.F., 0.15 μ F		
C4214	08T57851F15	T.F., 0.15 μ F		
C6201	08T93406F23	PP., 820pF		
C6202	08T93406F23	PP., 820pF		
C6203	08T57851F03	T.F., 0.015 μ F		
C6204	08T57851F03	T.F., 0.015 μ F		
C6205	08T57851F18	T.F., 0.27 μ F		
C6206	08T57851F18	T.F., 0.27 μ F		
Volumes				
VR4201	18T95027F01	Volume, K162 10k ohm B x 2 (TREBLE)		
VR4202	18T95027F01	Volume, K162 10k ohm B x 2 (BASS)		
VR6201	18T71727F01	Volume, 100k ohm B x 2 (CT), RKDA00 (VOLUME)		
VR6202	18T95028F01	Volume, K162 250k ohm MN (BALANCE)		
Speaker Terminal P. C. Board				
Capacitors				
● C7501	08S40805F07	CER., 1000pF		
● C7502	08S40805F07	CER., 1000pF		
● C7503	08S40805F07	CER., 1000pF		
● C7504	08S40805F07	CER., 1000pF		
● C7505	08S40805F21	CER., 0.022 μ F		
● C7506	08S40805F21	CER., 0.022 μ F		
DAC Switch P. C. Board				
Diodes/Capacitors				
D8202	48T44813F01	MA165TA		
D8203	48T44813F01	MA165TA		
D8204	48T44813F01	MA165TA		
D8205	48T44813F01	MA165TA		
D8206	48T44813F01	MA165TA		
C8201	23S57007F12	ELY., 22 μ F/10V		
C8202	23S57007F12	ELY., 33 μ F/10V		
C8203	23S57007F12	ELY., 33 μ F/10V		
Lamps				
PL8201	68T80326F02	Pilot, 5V/150mA		
PL8202	68T80326F02	Pilot, 5V/150mA		
PL8203	68T80326F02	Pilot, 5V/150mA		
Switch				
S6207	40T95028F01	Push, SPEC31 (DIGITAL 1, 2/ DAT MONITOR)		
DAC P. C. Board				
IC's				
IC8601	51T84774F01	TORX172		
IC8602	51T80475F01	TC74HCU04P		
IC8603	51T83506F01	TC74HC00P		
★ or	51T67211F01	HD74C00		
★ or	51T83506F01	TC74HC00P		
★ or	51T67211F01	HD74C00		
IC8605	51T72306F01	UPD4052BC		
IC8606	51T83506F01	TC74HC00P		
★ or	51T67211F01	HD74C00		
IC8607	51T91084F02	YM3623B		
IC8608	51T95091F01	CXD1162P		
IC8609	51T95181F01	LC7881 (DAC)		
IC8610	51T61180F02	NJM78L05A		
IC8611	51T80136F01	M5238P-DUAL		
IC8612	51T80136F01	M5238P-DUAL		
Transistors				
Q8601	48T43015U01	2SC2120		
Q8602	48T43015U01	2SC2120		
Q8603	48T43015U01	2SC2120		
Q8604	48T51118F02	2SA1015		
● Q8605	48T82763F02	DTC114EL		
▲ Q8605	48T82763F02	DTC114EL		
■ Q8605	48T82763F02	DTC114EL		
★ Q8605	48T62963F02	DTC114		
● Q8606	48T82762F02	DTA114EL		
▲ Q8606	48T82762F02	DTA114EL		
■ Q8606	48T82762F02	DTA114EL		
★ Q8606	48T62962F02	DTA114		
Q8607	48T57305F04	2SD1302		
Q8608	48T57305F04	2SD1302		
Q8609	48T57305F04	2SD1302		
Q8610	48T57305F04	2SD1302		
Q8611	48T81103F01	2SC1740		

Notes: ● : For West German model only (AD), ▲ : For North American model only (UZ), ■ : For Japanese model only (JA), ★ : For Canadian model only (UQ), Others : Common.

Symbol No.	Part No.	Description		
Diodes				
D8601	48T44813F01	MA165TA		
D8602	48T44813F01	MA165TA		
D8603	48T44813F01	MA165TA		
Coil/Transformer/Crystal/Jack				
L8601	24T50508F34	Coil, inductor 100 μ H		
T8601	25T948B2F01	TRANS PULS		
X8601	48T84727F01	Crystal, AT -51 16.9344M		
J8601	09T95188F01	Plate, Phono T6182		
Capacitors				
C8601	23T00138L10	ELY., 33 μ F/10V		
C8602	23T00138L10	ELY., 33 μ F/10V		
C8603	23T00138L10	ELY., 33 μ F/10V		
C8604	23T00138L10	ELY., 33 μ F/10V		
C8605	23T00138L12	ELY., 100 μ F/10V		
C8606	23T00138L12	ELY., 100 μ F/10V		
C8607	23T00138L12	ELY., 100 μ F/10V		
C8608	23T00138L12	ELY., 100 μ F/10V		
C8609	23T00138L12	ELY., 100 μ F/10V		
C8610	23T00138L12	ELY., 100 μ F/10V		
C8611	08T57705F13	MYL., 4700pF		
C8612	08S65480F13	CER., 10pF		
C8613	08S65480F13	CER., 10pF		
C8614	23T00138L03	ELY., 100 μ F/6.3V		
C8615	23T00138L03	ELY., 100 μ F/6.3V		
C8616	23T00138L03	ELY., 100 μ F/6.3V		
C8617	23T00138L10	ELY., 33 μ F/10V		
C8618	08T57298F01	CER., 0.1 μ F		
C8619	23T00138L17	ELY., 100 μ F/16V		
C8620	23T00138L12	ELY., 100 μ F/10V		
C8621	23T00138L19	ELY., 33 μ F/16V		
C8622	23T00138L19	ELY., 33 μ F/16V		
C8623	23T00138L19	ELY., 33 μ F/16V		
C8624	23T00138L53	ELY., 4.7 μ F/50V		
C8625	23T90772F41	ELY., 100 μ F/25V		
C8626	23T90772F41	ELY., 100 μ F/25V		
C8627	23T00138L19	ELY., 33 μ F/16V		
C8628	23T00138L19	ELY., 33 μ F/16V		
C8629	23T00138L19	ELY., 33 μ F/16V		
C8630	23T00138L19	ELY., 33 μ F/16V		
C8631	08T57705F30	MYL., 0.12 μ F		
C8632	08T57705F30	MYL., 0.12 μ F		
C8633	23T90772F42	ELY., 220 μ F/25V		
C8634	23T90772F42	ELY., 220 μ F/25V		
C8635	23T90772F70	ELY., 2.2 μ F/50V		
C8636	23T90772F70	ELY., 2.2 μ F/50V		
Filters				
LP8601	24T95189F01	LPF. 70910910-22K		
LP8602	24T95189F01	LPF. 70910910-22K		
Power LED P. C. Board				
LED				
● LD8701	48T66616F02	SLR-54VR3 (RED)		
▲ LD8701	48T66616F02	SLR-54VR3 (RED)		
■ LD8701	48T66616F02	SLR-54VR3 (RED)		
★ LD8701	48T10857W01	GL5PR8 (RED)		
Video P. C. Board				
IC's/Transistors				
IC9801	51T95186F01	IC, Video HA11513		
IC9802	51T80340F01	IC, NJM7812 MOLD		
▲ Q9801	48T81103F01	2SC1740		
▲ Q9802	48T81103F01	2SC1740		
▲ Q9804	48T81104F01	2SA933A		
▲ Q9805	48T81103F01	2SC1740		
Diodes/Coil/Jack				
D9801	48T44813F01	MA165TA		
▲ D9801	48T44813F02	MA165TA		
L9801	24T50508F34	Coil, Inductor 100 μ H		
J9801	09T72603F04	Plate, Phono (4P)		
Capacitors				
C9801	23T00149L37	ELY., 220 μ F/25V		
C9802	23T00149L26	ELY., 220 μ F/16V		
C9803	08T52714F13	CER., 0.01 μ F		
C9805	08T52714F13	CER., 0.01 μ F		
C9806	23T00149L28	ELY., 470 μ F/16V		
C9807	23T00149L28	ELY., 470 μ F/16V		
C9808	23T00149L13	ELY., 100 μ F/10V		
C9809	23T00149L16	ELY., 470 μ F/10V		
C9811	23T00149L16	ELY., 470 μ F/10V		
C9812	23T00149L26	ELY., 220 μ F/16V		
C9813	23T00149L53	ELY., 2.2 μ F/50V		
C9814	23T00149L13	ELY., 100 μ F/10V		
C9815	23T00149L53	ELY., 2.2 μ F/50V		
C9816	23T00149L13	ELY., 100 μ F/10V		
C9818	08T52714F13	CER., 0.01 μ F		
C9819	08T52714F13	CER., 0.01 μ F		

Notes : ● : For West German model only (AD), ▲ : For North American model only (UZ),
■ : For Japanese model only (JA), ★ : For Canadian model only (UQ), Others : Common.

Symbol No.	Part No.	Description		
Miscellaneous				
J9901	09T80329F01	Plate, Phono		
J9902	09T80329F02	Plate, Phono		
J9903	09T80329F01	Plate, Phono		
● F1101	65T42077U16	Fuse, Semko (1A)		
▲ F1101	65T66926F13	Fuse, 51NM (1A-250V)		
● F1102	65T42077U16	Fuse, Semko (1A)		
▲ F1102	65T66926F13	Fuse, 51NM (1A-250V)		
● F1301	65T42077U21	Fuse, Semko (3.15A)		
▲ F1301	65T66926F19	Fuse, 51NM (5A-125V)		
■ F1301	65T66926F19	Fuse, 51NM (5A-125V)		
■ J1001	09T88841F02	Outlet, AC		
▲ J1001	09T88841F03	Outlet, AC		
● J1002	09T51831F01	Socket, Switch		
LD8701	48T66616F02	LED SLR 54VR3 (Red)		
● P1001	28T43812P04	Plug, Cord		
▲ P1001	28T55335F02	Plug, AC Cord		
■ P1001	28T67434F01	Plug, AC Cord		
● P1002	09T51830F01	Plug, Switch		
Q7113	48T92782F01	2SC3964		
Q7114	48T92782F01	2SC3964		
Q7115	48T95041F01	2SA1673		
Q7116	48T95041F01	2SA1673		
Q7117	48T95042F01	2SC4388		
Q7118	48T95042F01	2SC4388		
Q8101	48T64375F01	2SA1380		
● T1001	25T95187F01	TRANS, Power		
■ T1001	25T95187F02	TRANS, Power		
▲ T1001	25T95187F03	TRANS, Power		

Notes : ● : For West German model only (AD), ▲ : For North American model only (UZ),
■ : For Japanese model only (JA), ★ : For Canadian model only (UQ), Others : Common.

Cabinet Assembly Parts List

NOTE: The parts without part numbers are not supplied.

Symbol No.	Index	Part No.	Description	Symbol No.	Index	Part No.	Description
●	1	2-B 01V94700F49	Assy., Front Panel	43	4-C	43A41837U04	Spacer, LED
▲	1	2-B 01V94700F49	Assy., Front Panel	44		09T84840F02	Lug, Style (32mm)
■	1	2-B 01V94900F53	Assy., Front Panel	●	4-C	43T53136F01	Bush, Cap
	2	1-D 15D72658F01	Cover, Top	47		09T51410F01	Holder, Fuse (SEMKO)
●	5	2-H 15D94698F03	Cover, Rear	49	5-A	43A41837U02	Spacer, LED
■	5	2-H 15D94698F04	Cover, Rear	51	5-B	14A96023F01	Insulator, Jack
▲	5	2-H 15D94698F05	Cover, Rear	53	4-F	03S43997P76	Screw, Countersunk (M3 × 6)
★	5	2-H 15D94698F06	Cover, Rear	54		03S40012G93	Screw, Tapping (M3 × 8)
	6	4-A 36B70885F07	Knob, Power	56	3-D	14S94461F27	Insulator, Cover
	7	4-A 36B83814F01	Knob, Speaker	57	1-G	09T95168F01	Plug, Jumper
	8	36A72661F01	Knob, Push Tone	58	5-H	07A84472F01	Frame, Opt Jack
	9	5-A 36A67333F01	Knob, Push (3 × 10)	59	3-A	43A83239F02	Holder, Lamp
	10	4-B 36B67336F02	Knob, Main Volume (B)	64	5-A	43A61758F04	Spacer, Lamp
	11	4-A 36A74341F02	Knob, Tone Volume (B)				
	12	75A96563F01	Pad, Tranleg				
	13	3-C 47C64899F60	Shaft				
	14	2-D 03C40121T17	Screw, W/Washer (M3 × 8)				
	15	03S44205G52	Screw, Pan (M4 × 14)				
	16	03S71031F04	Screw, Bind (M3 × 8)				
	17	03S40036U01	Screw, W/Washer (M4 × 8)				
●	18	1-H 15A82362F01	Cover, V-Sele				
●	19	1-H 03S71677F18	Screw, Bind (M3 × 12)				
	20	5-A 75A57803F04	Cushion				
	22	03S71031F09	Screw, Countersunk (M3 × 8)				
	23	1-F 14S53018F42	Insulator				
	27	03C40121T18	Bolt Hex W/Double Washer (M3 × 10)				
	29	03S40018G08	Screw, Tapping (M3 × 8)				
	31	03A82468F01	Screw, Tapping (M3 × 10)				
	32	03S71031F03	Screw, Bind (M3 × 6)				
●	34	2-H 14A82952F01	Insulator, V-Sele				
	35	3-D 03S40018G12	Screw, Tapping (M3 × 10)				
	37	1-G 43B41625J02	Support, Cord				
	38	2-H 29T66964F01	Terminal, GND				
	40	03S43997P42	Screw, Countersunk (M3 × 6)				
▲		05B41695J02	Rivet, Push				

Notes: ● : For West German model only (AD), ▲ : For North American model only (UZ), ■ : For Japanese model only (JA), ★ : For Canadian model only (UQ), Others : Common.

Exploded View (Cabinet)

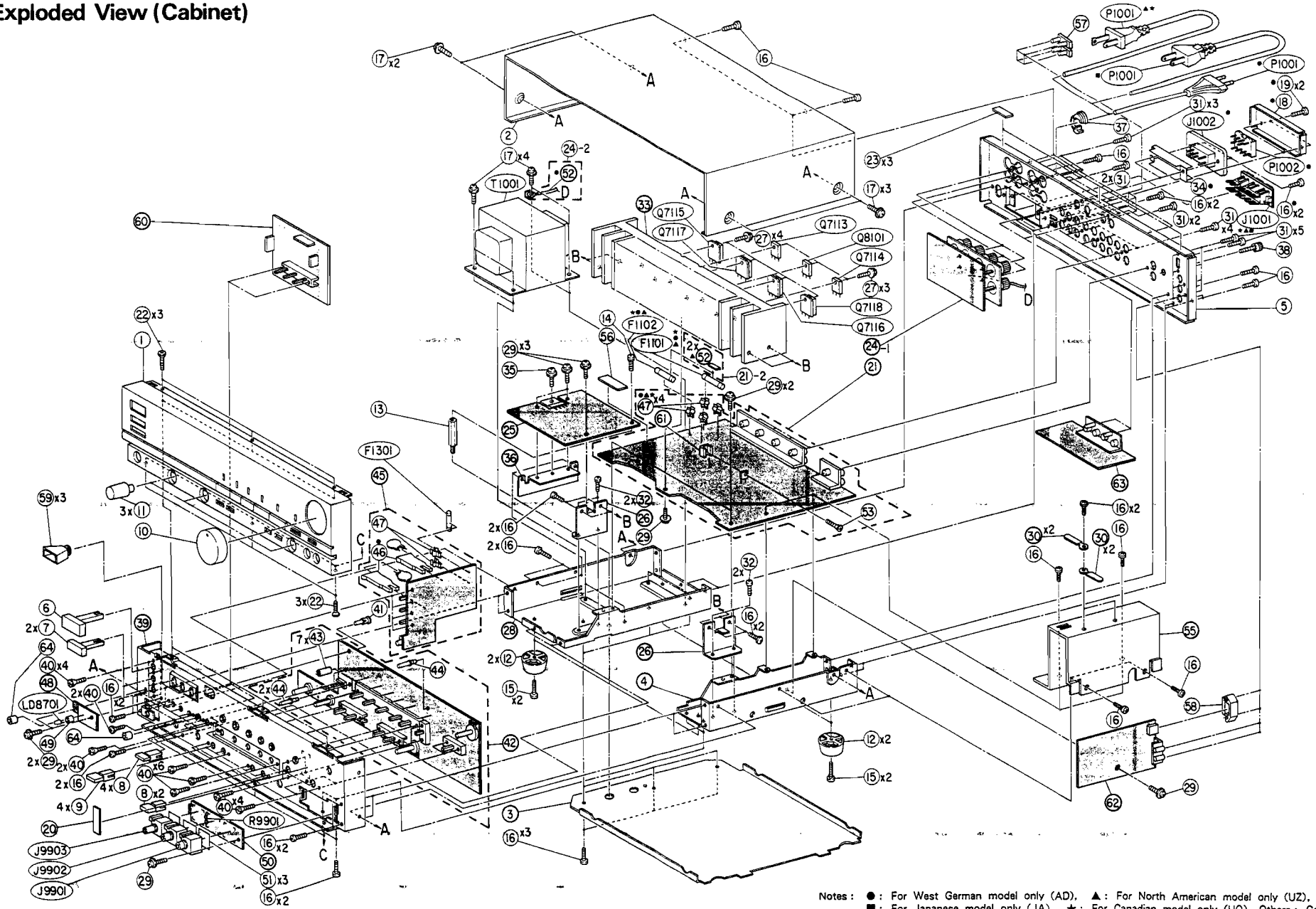

Notes : ● : For West German model only (AD), ▲ : For North American model only (U2),
 ■ : For Japanese model only (JA), ★ : For Canadian model only (UQ), Others : Common.

Packing Assembly Parts List

Symbol No.	Part No.	Description	Symbol No.	Part No.	Description
■	101	68P81707F60			Owner's Manual
●	101	68P81707F61			Owner's Manual
▲	101	68P81707P84			Owner's Manual
★	101	68P81707F81			Owner's Manual
	102	56B40442T08			Packing, Front Frame
	103	56D94704F01			Tray, Packing
●	104	56S83833F45			Carton, Packing
■	104	56S83833F46			Carton, Packing

Notes: ● : For West German model only (AD), ▲ : For North American model only (UZ),
 ■ : For Japanese model only (JA), ★ : For Canadian model only (UQ), Others : Common.

Packing Method View

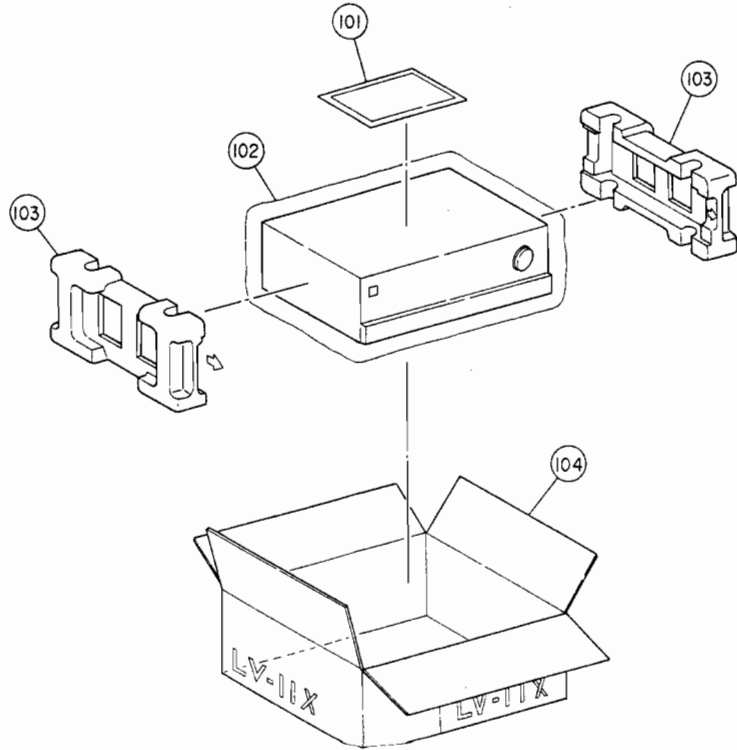

Semi-Conductor Lead Identifications

NJM7815FA : IC1101
 NJM7805 : IC1103

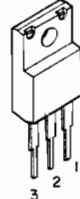
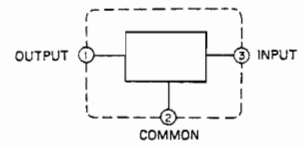
NJM7915FA : IC1102
 NJM7905 : IC1104

M5220P : IC2101
 M5238P : IC8611, 8612

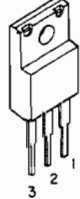
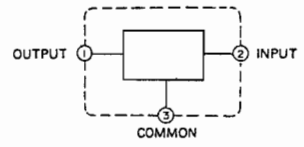
NJM4558D : IC4201, 4204

CX770 : IC6101, 6102, 6103, 6104

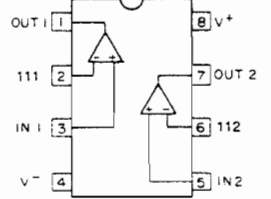

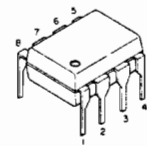
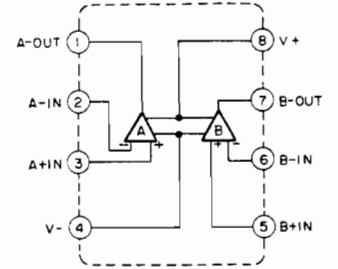
STK3062 : IC7101

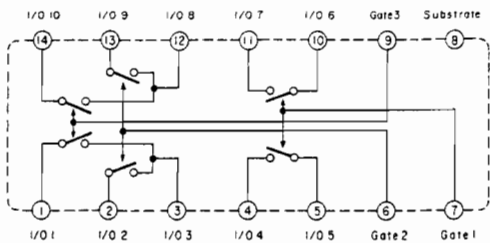
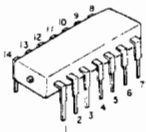

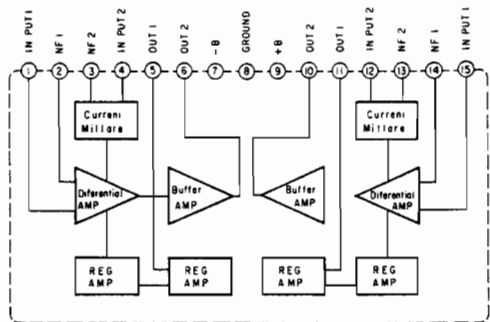
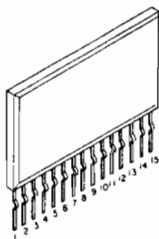
TA7317P : IC8101

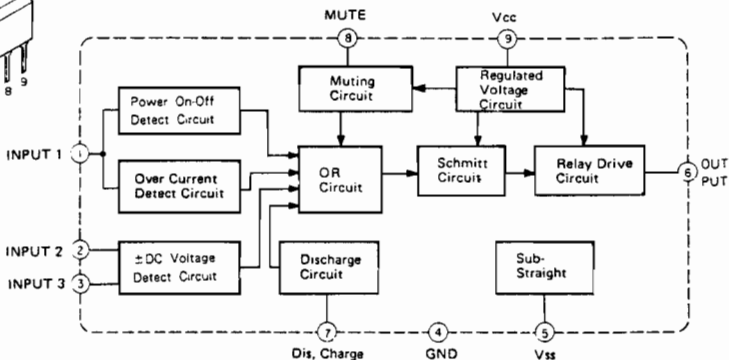
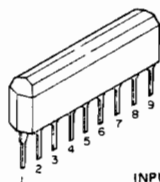

TORX172 : IC8601

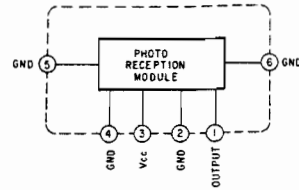
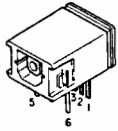

TC74HCU04P : IC8602

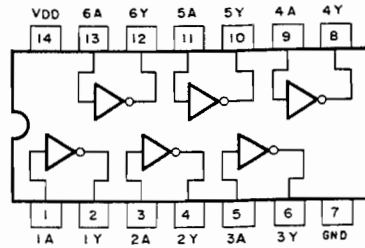
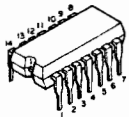

TC74HC00P : IC8603, 8604, 8606

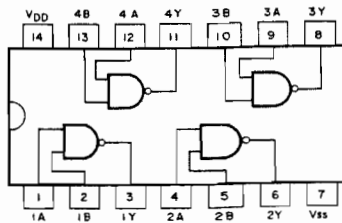
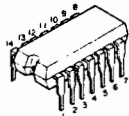

μ PD4052BC : IC8605

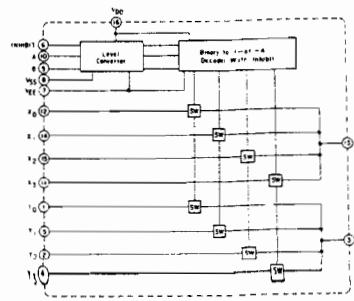
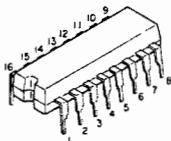

YM3623B : IC8607

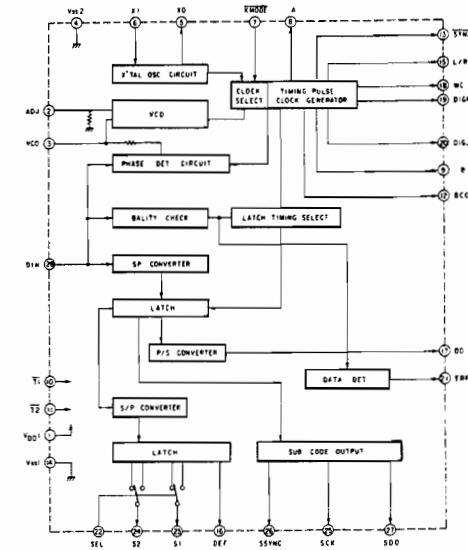
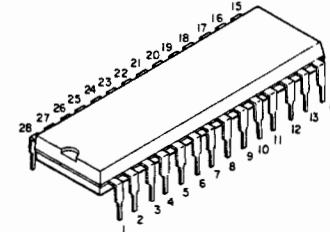

CXD1162P : IC8608

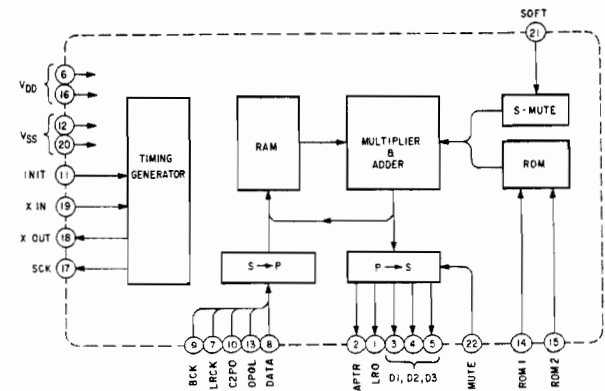
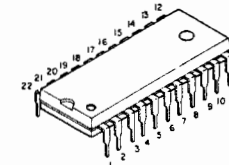

LC7881 : IC8609

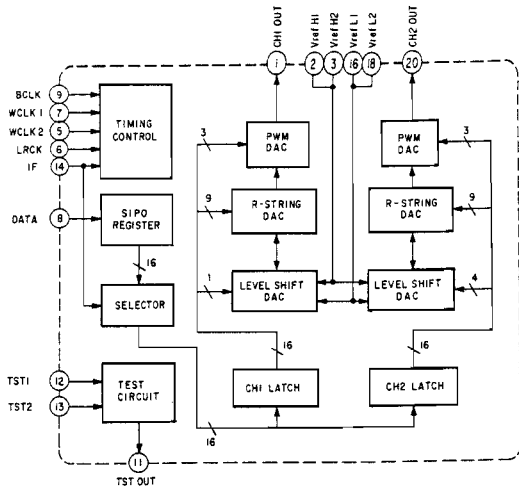
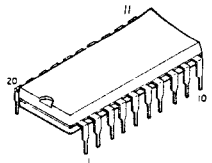

NJM78L05A : IC8610

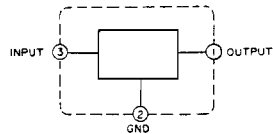

HA11513 : IC9801

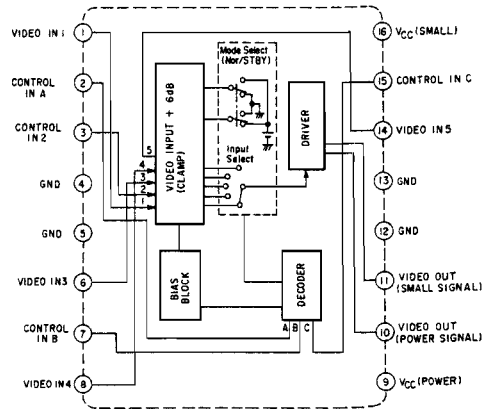
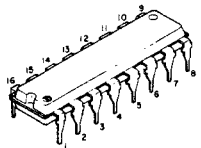

- 2SA970 : Q7101, 7102, 7109, 7110
- 2SC2240 : Q7103, 7104, 7111, 7112
- 2SC2120 : Q8601, 8602, 8603
- 2SA1015 : Q8604
- 2SD1302 : Q8607, 8608, 8609, 8610
- 2SC1740 : Q8611, 9801, 9802, 9805
- 2SA933A : Q9804



- 2SB1258 : Q7105, 7106
- 2SD1785 : Q7107, 7108

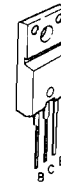

- 2SC3964 : Q7113, 7114
- 2SA1360 : Q8101



- 2SA1673 : Q7115, 7116
- 2SC4388 : Q7117, 7118



DTC114EL : Q8605

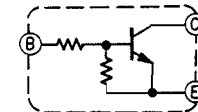
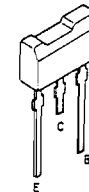

DTA114EL : Q8606

