



IV BAL



PYTACORA



PITAGORAS



PYTACORA

PHYLOLAVS

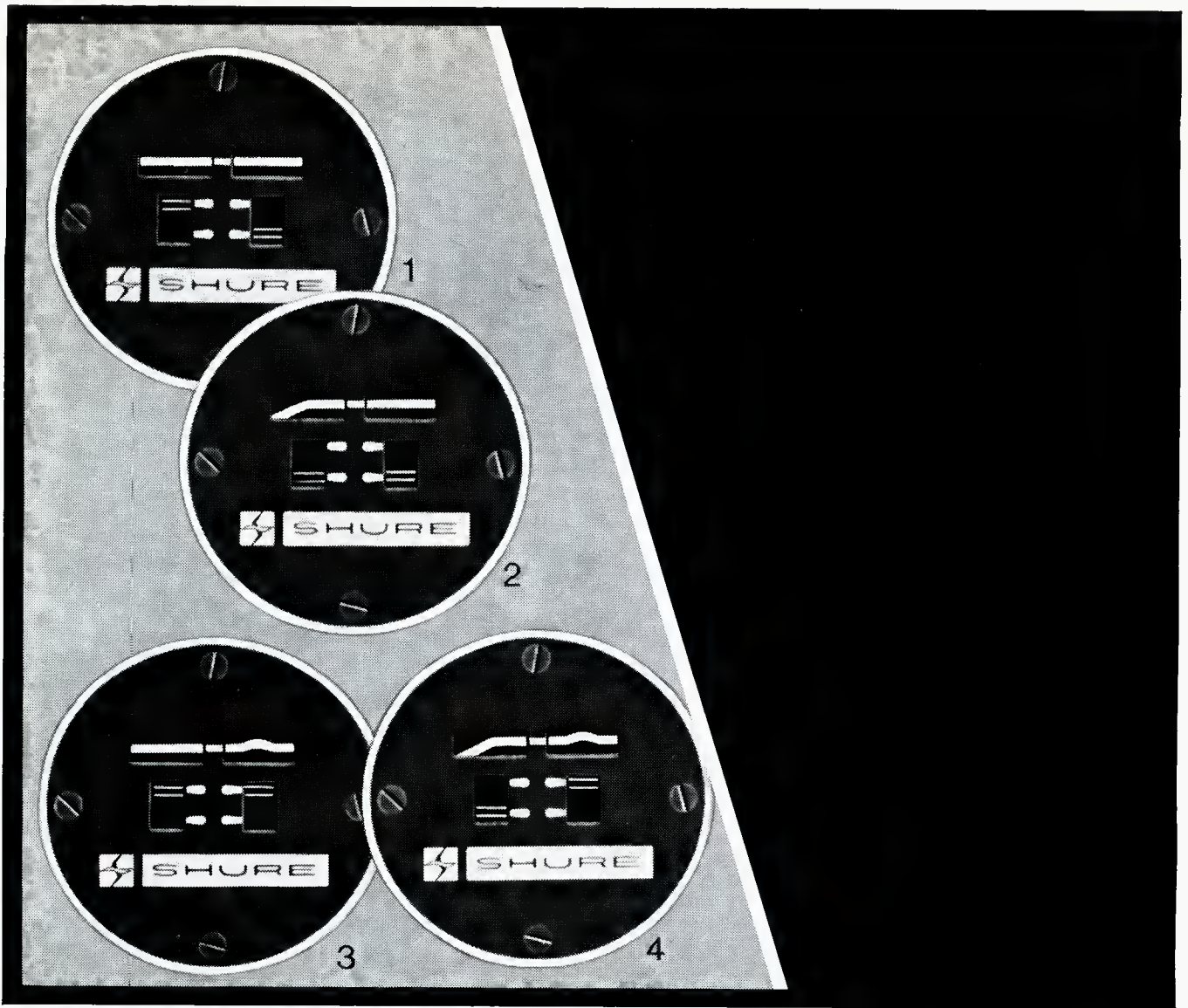

What you see is what you get.

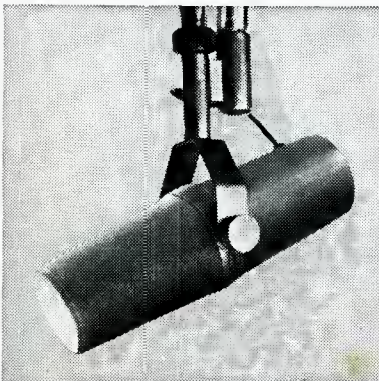

The extraordinary Shure SM7 professional microphone features something you've never seen before: a *built-in Visual Indication Response Tailoring System* that offers you four different frequency response curves—and shows you the curve you've selected with a graphic readout (see above) at the back of the microphone! Choose: 1. flat response; 2. bass roll-off; 3. presence boost; 4. combination of roll-off and presence. And there's more: the SM7 delivers exceptional noise isolation with a revolutionary pneumatic suspension mount . . . an ultra-wide, ultra-smooth frequency response . . . an integral "pop" and wind filter . . . and a cardioid pickup pattern that looks "text-book perfect." The Shure SM7 Studio Microphone was extensively field-tested in recording studios and broadcasting stations! Write:

Shure Brothers Inc.
 222 Hartrey Ave., Evanston, Ill. 60204
 In Canada: A. C. Simmonds & Sons, Ltd.



Circle 10 on Reader Service Card

COMING NEXT MONTH

● The world of audio-visual occupies our editorial pages via a major feature article by columnist Martin Dickstein. In his article, called *THE FLASHER*, he describes a modern multi-media stage show. Lighting, film, stage action—all were used in a well-integrated show that was billed as the first X-rated rock concert. It was recently produced in New York City.

You don't have to have a big lavish factory set in a modern industrial complex to produce first-rate equipment. Next month we will visit Gately Electronics' production facilities as they exist upstairs and downstairs in the Philadelphia suburb Havertown.

And there will be our usual columnists: Norman H. Crowhurst, Martin Dickstein, and John Woram. Coming in *db*, The Sound Engineering Magazine.

ABOUT THE COVER

● Once again, art director Bob Laurie has come up with an interesting and provocative idea. The panels shown were created by Franchino Gafurio in 1492 and are called *Theorica Musice*. The biblical father of music, Jubal, is shown as he studies the harmonic consonances of weighted hammers at the upper left. In the other panels Pythagoras and his follower Philolaus demonstrate music making using harmonically related water filled glasses, weight-stretched strings, and different length pipes. The illustration itself is from the picture collection of the New York Public Library.

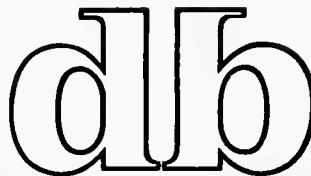

THE SOUND ENGINEERING MAGAZINE

JANUARY 1974 VOLUME 8, NUMBER 1

22	INCREMENTAL OPTICAL ENCODERS Richard Factor
28	THE NEW STANDARD FOR WEIGHTED PEAK FLUTTER MEASUREMENTS John G. McKnight
31	LOW COST FOUR CHANNEL REMOTE BOX Joseph Saldana
2	LETTERS
6	THE SYNC TRACK John Woram
10	THEORY AND PRACTICE Norman H. Crowhurst
15	SOUND WITH IMAGES Martin Dickstein
18	NEW PRODUCTS AND SERVICES
34	CLASSIFIED
36	PEOPLE, PLACES, HAPPENINGS

db is listed in **Current Contents: Engineering and Technology**,

Robert Bach PUBLISHER	Larry Zide EDITOR
Bob Laurie ART DIRECTOR	John Woram ASSOCIATE EDITOR
A. F. Gordon CIRCULATION MANAGER	Hazel Krantz COPY EDITOR
Eloise Beach ASST. CIRCULATION MGR.	Richard L. Lerner ASSISTANT EDITOR
GRAPHICS Crescent Art Service	

db, the Sound Engineering Magazine is published monthly by Sagamore Publishing Company, Inc. Entire contents copyright © 1974 by Sagamore Publishing Co., Inc., 980 Old Country Road, Plainview, L.I., N.Y. 11803. Telephone (516) 433 6530. *db* is published for those individuals and firms in professional audio-recording, broadcast, audio-visual, sound reinforcement, consultants, video recording, film sound, etc. Application should be made on the subscription form in the rear of each issue. Subscriptions are \$6.00 per year (\$12.00 per year outside U. S. Possessions, Canada, and Mexico) in U. S. funds. Single copies are \$1.00 each. Controlled Circulation postage paid at Harrisburg, Pa. 17105. Editorial, Publishing, and Sales Offices: 980 Old Country Road, Plainview, New York 11803. Postmaster: Form 3579 should be sent to above address.



Recording session at Mastertone Studios, N.Y.C.

Stanton - unseen in this picture - but crucial to it!

When you demand the strictest requirements for recording and playback, Stanton's Series 681 cartridges are the calibration standard. And there is a 681 model engineered specifically for each of these critical applications.

The Stanton 681A - for cutting head calibration

With Stanton's Model 681A, cutting heads can be accurately calibrated with the cartridge, for it has been primarily designed as a calibration standard in recording system checkouts for linearity and equalization. Frequency response is factory calibrated to the most rigid tolerances and the flattest possible response is assured for precise alignment of recording channels. Implicit in this kind of stability and constancy is a reliability factor unmatched by any other cartridge.

The Stanton 681EE - for critical listening

In critical playback auditioning Stanton provides the evaluation standard in its model 681EE. In this application, the Stanton 681EE offers the highest obtainable audio quality. It is designed for low distortion tracking with minimum stylus force, regardless of the recorded velocity or the distance of the groove from the disc center. High compliance, low mass and low pressure assure perfect safety even on irreplaceable records.

All Stanton Calibration Standard cartridges come packed with calibration test results for that individual cartridge.

For complete information and specifications write Stanton Magnetics, Inc., Terminal Drive, Plainview, L.I., New York.



STANTON

All Stanton cartridges are designed for use with all two and four-channel matrix derived compatible systems.

Circle 13 on Reader Service Card

letters

The Editor:

I have recently read Norman Crowhurst's column in the November issue of your magazine and found it to be quite interesting. It appears to me that the basic message he attempts to convey is that the institutes of higher education in the U.S. are not worth going to. He also makes an unfavorable comparison between the schools in the U.S. and those of England.

advertisers index

Auditronics	17
Bose	4
Burwen Labs	5
dbx Inc.	Cover 3
Electro-Voice	Cover 4
Eventide	14
Fidelipac	4
Gately	21
Gotham Audio	6
Orban/Parasound	16
Polyline	8
Scott Instrument	10
Shure	Cover 2
Sound 80	7
Stanton Magnetics	2
Tascam	3, 9
Telex	13
Timekeeper	front flap
Waters	11
Woram Audio	19

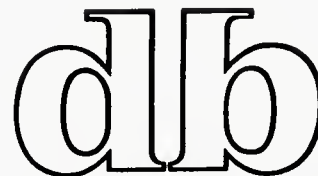

THE SOUND ENGINEERING MAGAZINE

SALES OFFICES

New York

980 Old Country Road
Plainview, N.Y. 11803
516-433-6530

Dallas

Roy McDonald Associates, Inc.
Stemmons Tower West
Suite 714
Dallas, Texas 75207
214-637-2444

Denver

Roy McDonald Associates, Inc.
3540 South Poplar Street
Denver, Colorado 80237
303-758-3325

Houston

Roy McDonald Associates, Inc.
3130 Southwest Freeway
Houston, Texas 77006
713-529-6711

Los Angeles

Roy McDonald Associates, Inc.
500 S. Virgil
Suite 360
Los Angeles, California 90020
213-381-6106

Portland

Roy McDonald Associates, Inc.
2035 S. W. 58th Avenue
Portland, Oregon 97221
503-292-8521

San Francisco

Roy McDonald Associates, Inc.
Baybridge Office Plaza, Suite 265
5801 Christie Avenue
Emeryville, California 94608
415-653-2122



The Model 10 Mixing Console

When you've got more talent than money

Any mixing console is simply a creative tool. Getting the most out of it calls for imaginative insight into music and skill in the practical application of sound.

If you've got the talent but you don't have the money,

you're exactly who we built this board for.

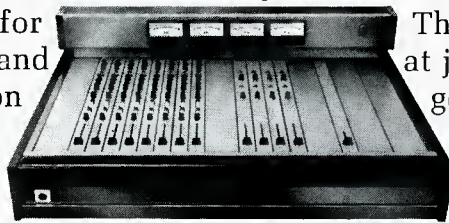

The basic 8-in, 4-out board starts at just \$1890. From there you can go to 24-in, with options and accessories enough to fill a studio.

The TASCAM Model 10. It gets your inside outside.

 **TASCAM CORPORATION**

5440 McConnell Avenue
Los Angeles, Calif. 90066
Circle 18 on Reader Service Card



RUGGED!

The BOSE name and a full FIVE YEAR WARRANTY are your assurances of reliability and performance with the BOSE 1800™ Professional Power Amplifier.

- 800 Watts rms
- LED Displays
- Over 1,300 Square Inches of Heat Sinks
- Sturdy Packaging
- Rack Mountable

Please send complete information on the BOSE 1800 to:

Name _____

Address _____

City _____ State _____ Zip _____

Mail to: BOSE, Dept. DP,
The Mountain, Framingham, Mass. 01701

I agree with a considerable proportion of his comments regarding technical aspects of education in the universities. I have, indeed, received course instruction from teachers who did not understand Mr. Crowhurst's statement, "The good teacher's capability can be summed up as knowing how learning happens in a variety of different human beings and being competent at causing it to happen." Conversely, I have also received instruction from teachers who did, in fact, have the vision and insight to be able to truly teach their students.

My observations and comments center on the relative interests of the students, rather than on the various qualifications of the specific instructors involved. I have interviewed for employment and have worked with quite a number of individuals who would desire to be called engineers. I have certainly observed a wide range of capabilities in these people. While I recognize that one cannot categorize human beings into strictly defined groups and/or classifications, I maintain that there is one underlying factor which characterizes those whom I feel are competent engineers. That factor is the unrelenting interest in the work they perform. I have observed such interest in those individuals who

have completed college educations, as well as in those who have never entered a university. I have found a number of people with no formal education whom I would feel very confident to employ as engineers.

Many of these people have been able to learn all that is available in a college curriculum without formal attendance at an institution. However, it has generally taken them a longer period of time to learn the required technical material than would, generally, be expected for those who have completed a formal curriculum. The decision to go to college, or the decision to attempt to accumulate the equivalent expertise by becoming a technician *in lieu* of college, is purely an individual choice. But I maintain that the quickest way of learning is through a formal education. At the same time, a student should not limit himself strictly to text books. Part-time employment for practical experience in electronics is invaluable, as well as are home hobby projects.

Above all else, the good prospective engineer will recognize that there is no substitute for interest and hard work.

*John Pritchett,
Manager Electronics Engineering
James B. Lansing Sound, Inc.*

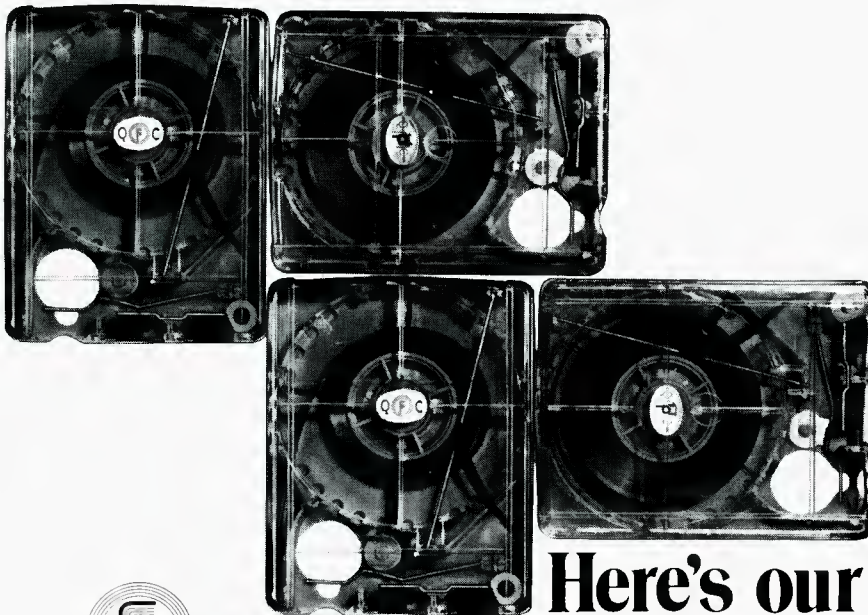

Here's our story...

Want more? Contact your Fidelipac Distributor and learn why more Fidelipac Automatic Tape Cartridges are in use throughout the world than all others combined.

FIDELIPAC®

3 Olney Avenue • Cherry Hill, New Jersey 08034 • (609) 424-1234
Fidelipac is a registered trademark of TelePro Industries Incorporated

The Editor:

The cover of the October issue of **db** is interesting, and happened to catch my eye.

Recently, I purchased an Edison radio model R5. I believe it was built in 1929. But I have a problem with which I thought you may be able to help. Unfortunately, there was no schematic with the set when I purchased it, and searching late 1920's and early 30's periodicals has produced no results.

The receiver unit is type 7R, serial number 701601, and the power unit is type 8p, serial number 819892. Both are still in excellent condition, except for several missing tubes. Also, with the bad luck in finding a schematic, I cannot find any information about the Edison Radio Co.

My question is: would you or someone in your organization know where I might find a schematic, or information on Thomas A. Edison, Inc. such as where I might contact them?

David A. Malin
112½ N. Mitchell
Cadillac, Michigan 49601

This stumped us. Anyone out there have any information for Mr. Malin? Please send it to the above address.

Who would want to own...an 80dB dynamic range record?

You would, once you heard one.

Examples of records selling because of superb sound, alone, are becoming more numerous. And small wonder!

For, in a recent survey of customers who already own high-quality, home sound systems, over 80% of those who responded to a request for suggested improvements said, "Do something to get better sounding records, tapes and FM."

How can records of 80dB dynamic

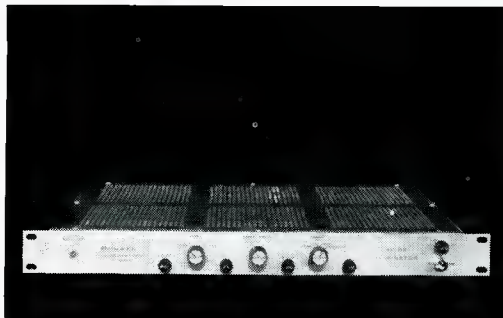

range be produced? The fact is that only the Burwen Noise Eliminator makes such recording possible . . . and it's expensive! You will be convinced, as we are, that it can boost your record sales 10% to 20% . . . and decide that it is more than worth the investment.

To get complete facts on the Burwen Noise Eliminator, Model 2000 . . . just call or write:

 **Burwen**
LABORATORIES, INC.

209 MIDDLESEX TURNPIKE, BURLINGTON, MA. 01803/TEL. (617) 273-1488

Circle 22 on Reader Service Card

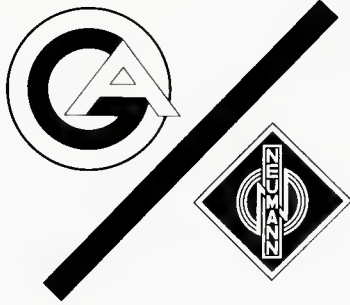

THE TRUTH ABOUT PATTERNS

Microphones may be classified into pressure and pressure-gradient transducers. The former produce non-directional, while the latter include *all* directional patterns. It is true that all of the switchable characteristic microphones also have an omni-directional pattern position, but it is formed through the electrical combination of two cardioids and therefore largely behaves like a directional microphone.

As one approaches a pressure (omni) microphone to within close proximity, the effective impression is "it gets louder", while the same movement in front of a directional mike produces the additional impression "it comes closer". There will be many situations in which one will not want to neglect this effect.

Aside from that, *only* directional microphones can have parallel running frequency response curves up to the highest frequencies in both a diffuse and a direct sound field. In a diffuse sound field, the microphone receives sound evenly from all directions, while in a direct (free) sound field, it comes predominantly from on axis. Pressure transducers of the usual studio size will *always* drop their high frequency response when the distance between the sound source and the microphone is increased. For very small distances, the directionality of a microphone is of no significance. The choice, therefore, will largely depend on whether eliminating bass boost, ensuing preamp overload and popping are the paramount considerations, in which case you must use an omni, or whether it is desirable that a vocalist's change in his microphone distance becomes fully audible, making the recording more dynamic and realistic, in which case a directional microphone must be selected.

All NEUMANN microphones are designed for only one optimum level of quality. It's been that way for over 40 years. The 12 different models with as many different prices are each aimed at serving a specific purpose. We'll be happy to advise you on yours. Call on us.

Stephen F. Temmer
President, Gotham Audio Corporation

GOTHAM
AUDIO CORPORATION

Headquarters: 741 Washington Street,
New York, NY 10014 (212) 741-7411
West Coast Sales Office: 1710 N. LaBrea Ave.,
Hollywood, CA 90046 (213) 874-4444

John M. Woram

THE SYNC TRACK

• Anyone who's had more than an hour's worth of experience on a playback session has probably heard some, or all, of the following:

"I like to listen loud, so I know what's really on the tape."

"It sounds different at home."

"I can't hear the bass!!"

"That speaker isn't giving me what's really on the tape."

The list could go on for pages, but you get the idea, I hope. When it comes to the subject of monitor systems, all is not quite as scientific as we might wish. People who wouldn't bat an eyelash if you replaced your kilobuck console with another one will break into a cold sweat if the favorite speaker gets moved by more than half an inch. And the engineer who would order a 16 track tape recorder after comparing spec. sheets wouldn't dream of being so casual when it comes to selecting the ultimate speaker for his control room.

Speakers cannot be fully described on paper, and even if they could, there are significant differences of opinion about what a speaker is supposed to sound like.

For example, we recently held a four day Producers-Arrangers Workshop at the Institute of Audio Research. The idea was to bring producers and arrangers up-to-date on the latest developments in technology. The first session was devoted to the monitor system. We set up five different pairs of speakers—all in about the same price bracket—and compared them. The differences were of course varied, as were the opinions

about which system was the best.

The speakers represent three different manufacturers—each of which apparently had a different conception of that illusive term, "reality." Each system had its own personality, and a program recorded using one of them would certainly sound somewhat different on another. The key word here is probably degree. That is, as long as one speaker is not violently out of line from the others, we should find our program sounding reasonably well no matter what system is used.

But, what's *really* on the tape? That's a question that can't take much scrutiny. The more you think about it, the more evasive the answer becomes.

What's on the tape? A collection of iron-oxide particles that somehow or other play back as a musical program. God knows what it should really sound like. The program arrives at the tape-recorder input after finding its way from a collection of microphones through a console, all the while being monitored over the control room speaker system. If one of the musicians didn't sound quite right, you may have changed microphones, until you found a more pleasing sound. But what if you had changed speakers instead? No doubt a different speaker would make just as much difference as a different mic.

So, where is this reality for which we're all searching? What combination of microphone and speaker will provide the ultimate truth? And, who will recognize it for what it is? And,

Is your present monitor system too good to be true?

If your present monitor system is too good, that's too bad. Chances are, with your system, you're mixing to a sound that doesn't exist under normal broadcast or listening conditions. The result is a mix that sounds flat. And dull. The sound isn't true.

We saw a need. A need for a monitor system that compensated for this variance. Not an inferior system which sacrifices quality or response, but instead a system of control. We saw the need for a sophisticated monitor system that allows engineers and producers to control a mix to his advantage and achieve just the sound he desires.

Our top engineers have recently developed just this type of system for our own studios. After many system changes and refinements,

they're finally satisfied. The result is the SOUND 80 Bi-amplified Monitor System.

The SOUND 80 Bi-amplified Monitor System is a high quality studio monitor system that gives true sound without scrimping on power. The heart of our system is an Altec 604 E front mounted in an 8 cu. ft. tuned reflex enclosure.

It's powered by a 120 Watt 2 channel amplifier featuring SOUND 80's EC 1500 electronic crossover/shelving equalizer. Our equalizer extends response a full two octaves. We offer control, too. The kind of control that engineers have been missing until now.

You'll be getting better mixes immediately. Truer mixes. Now you'll sound as good on the air as you do in the studio.



If your present monitor system is too good to be true, listen to us. We have a truly good monitor system.

SOUND80

BIAMPLIFIED MONITOR SYSTEM

2709 East 25th Street, Minneapolis, Minnesota 55406 • (612) 721-6341
(Circle reader card no.)

Circle 26 on Reader Service Card

when will these questions be over?

Probably never. If the ultimate truth were known to anyone except ad writers, there'd be only one speaker on the market. (Probably only one mic, too.)

Unfortunately, it would probably be a good idea to have as many different speakers as microphones. However, that's impractical for many reasons, so we must make do with one, perhaps two, different systems, and then try to make whatever allowances we can for all the others. However, it's a mistake to expect either a recording or a mixdown to sound the same no matter where it's played.

Which brings up another consideration. Once you've decided that the XYZ-1 is the perfect speaker, you install them in your studio and then get a pair for home. Now, you can take tapes home and evaluate them in between sessions.

Surprise, surprise!! It doesn't sound the same, does it? That other consideration is the listening room itself. Remember, a speaker is a transducer.

TRANSDUCER—a device that receives energy from one system and re-transmits it, often in a different form, to another.

—Random House Dictionary of the English Language.

So, a speaker receives electrical energy (from the amplifier) and transmits acoustical energy (into the listening room). No one doubts that the speaker depends on the amplifier for energy received. But, just as important—perhaps even more so—it depends on the listening room environment for the energy transmitted. If the speaker were placed in a vacuum, no sound would be heard; no doubt the ultimate effect. However, with the exception of the top brass at some record companies, few of us do our listening in a vacuum. Nevertheless, any listening room is still a significant influence on the sound, and cannot be ignored when evaluating a speaker.

Standing waves are one of the more obvious hazards. If you haven't experienced the joys of dealing with them, try this simple (though boring) experiment. Tune an oscillator to some low frequency. Listen for a moment

and then slowly walk about the room. The apparent level will vary considerably, especially in a small room, as you move about. Try to decide on the best listening location, and then try another frequency. Chances are the best location will now be at somewhere else. In short, no matter where you are sitting, some frequencies will suffer due to the effects of standing waves within the room. And, depending on where you are, your evaluation of the speaker could be colored by the effects of the room. Acousticians go to a lot of grief trying to design rooms that minimize standing waves and all the other horrors that crop up, but they don't always succeed completely.

Of course, you can always do your mixing out-of-doors, so that standing waves, room resonances, reflections, and whatever are eliminated. But, then what? You may finally create the ultimate mixdown, and as long as everyone else does their listening outside, it should sound great. But with the exception of the transistors-at-the-beach crowd, most folks do their listening indoors, so your super sound will inevitably be colored by a multiplicity of unpredictable effects which vary from one listening room to another.

And so, even if you have just built the perfect mixdown room, your tape will still sound different elsewhere. You can really waste a lot of time trying to prepare a tape that will be impervious to the effects of the room in which it is being played.

Of course, just because you have no control over where your tape or disc will eventually be played doesn't mean that any old room will do fine for mixing. If your room has certain obvious faults, they should be corrected if possible. Monitor equalization immediately comes to mind, however this is not *the answer* to every monitoring problem that comes up. For example, the standing waves we were just talking about are largely a function of the physical characteristics of the room. If 450Hz is severely attenuated due to standing waves, you can boost all you want and accomplish nothing. Or, you can blame the speaker for being down at 450 Hz. Or, better yet, you can do something to break up the standing wave.

And, if the room is too live, an absorptive material may be used. However it too, may cause problems. Some materials absorb high frequencies quite well but have little effect on low frequencies. As a result, the sound gets muddy, and the speaker is accused of being deficient.

And so on.

The point? A speaker cannot really be evaluated out of context. Just as

a certain microphone is just right for a particular musical instrument within a particular musical setting, a certain speaker will be more impressive in one room than in another.

Now then, once you've decided on the proper speaker, what about listening level? Is there any such thing as a correct monitor level?

Here's where we have to take into account that part of the monitor system over which we have the least control—the ear. Obviously, the ear has a frequency response of its own. Not so obvious is the fact that this response varies drastically with listening level. The research work of Fletcher and Munson on this phenomenon should be required reading for all studio personnel.

Simply stated, as the listening level is reduced, the ear becomes less sensitive to extreme low and high frequencies. So, if a tape is mixed at a loud listening level and then played back softly, the bass will disappear and so will the high end. The low end deficiency will be most noticeable, especially since the producer will probably go into some form of hysteria and start screaming obscenities at the speaker.

But unfortunately, it's not the speaker's fault—its the listener's, and the problem is beyond the control of engineering. So when you listen back at a different level, be prepared to hear a different balance. The correct monitor level would be that level at which the record will eventually be played by the consumer.

That's a pretty dumb statement when you consider that everyone listens at a different level setting. Probably a more satisfactory answer would be to mix at the lowest volume setting that still remains practical. Then if your masterpiece gets played back at a high level, the apparent boost at the frequency extremes will add a little more excitement, and lower level playbacks will not lack body.

The non-linear characteristic of the ear may be unavoidable, but it should be understood. However, it's difficult to sooth an irate producer with a physics lecture. He probably doesn't understand this little feature of the ear and honestly believes something is wrong with the monitor system. Prolonged discussion on hearing thresholds will surely not be appreciated. It might be best to preface a low-level playback with some sort of knowledgeable statement like, "I hope the bass is down enough for you." Of course, it won't be, but at least you've let him know that the balance shift is to be expected. Then maybe after the session you can get into the why's and wherefore's. ■

Plastic Reels Shipped from Inventory
Mfrs. of Amerline reels
Polyline Corp.
312/298-5300
1241-Rand Rd. Des Plaines, Ill. 60016

FOR MAG TAPE



Series 70 Recorder/Reproducers

When you've got more talent than money

TASCAM Series 70 recorder/reproducers were designed for people who've outgrown high-end consumer audio products but can't afford full professional studio gear.

Whether you need single, two or four channels, you define the Series 70...it doesn't define you. Your choices are expanded instead of restricted without paying a performance penalty.

The versatile Series 70 electronics come in two versions, one for direct recording and one for use with a mixing console like our Model 10. Either way you'll find uncommon quality and reliability.

Series 70 recorder/reproducers. When you've got more talent than money.



TASCAM CORPORATION

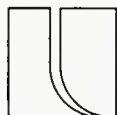

5440 McConnell Avenue
Los Angeles, Calif. 90066

Circle 27 on Reader Service Card

THEORY AND PRACTICE

● Engineering has always been more my "bread and butter" than education has, thus far. What worries me about education is the question whether our children or grandchildren will have any bread and butter if we do not do something about it now. And, hopefully, if we do the right things, I will be able to get some bread and butter from the doing of them.

During the month, an engineering type of question came in from a reader, connected with deriving the phase shift networks connected with various forms of quadriphonic sound. In a block schematic, we show nice rectangular blocks, with signals flowing through them, and we indicate

phase relationships, combinations that produce vector and rotational signals, and so forth.

The point I want to get at here, without going into how quadriphonic works for the moment, is the basic nature of networks that produce phase differences. From the viewpoint of how they are used in quadriphonic systems, all we need to know at this point is that if you combine two equal signals having a phase difference of 90 degrees, the resultant, applied for example to a 45/45 disc system, is a circular rotation, rather than a movement along either 45 degree axis. And, if you reverse the process, taking such 90 degree phase-displaced outputs from a

45/45 system, and applying more 90 degree phase shifts, you can derive front and back, matrixed with left and right signals, one for each corner.

The vector analysis of all that has been gone over by various people, so we do not need to repeat that here, at least I do not believe we do. After this has appeared in print, letters from readers may prove that assumption wrong. What I want to tackle here is the kind of block diagram that shows the same input signal going to two different blocks, one of them indicating 0 degrees phase shift, and the other indicating 90 degrees phase shift.

What somebody who does not know any different is apt to assume is that

new pocket sized professional sound level meter for under \$100



The new Scott 451C sound level meter is the first truly professional instrument that fits in your pocket and costs only pocket money.

It gives instant readings at the touch of a button to ANSI type S3C accuracy with industry standard "C" weighting for flat response. Its range of 45 to 130dB SPL lets you check ambient background levels as well as the signals of interest. It measures the complete range of sounds likely to be encountered by the audio engineer or the advanced audiophile.

It's got a handsome, rugged all metal case and a big meter face that's easy to read. It's also a lot of fun to use. Its battery lasts all year. It lasts indefinitely and it's fully guaranteed for two years. It costs only \$98.00. It's available from distributors whose names we'll send you with full product specifications.

Scott Instrument Laboratories
Division of Eastern Air Devices
30 Cross Street
Cambridge, MA 02139



Copies of db on Microfilm

Copies of all issues of **db—The Sound Engineering Magazine** starting with the November 1967 issue are now available on 35 mm. microfilm. For further information or to place your order please write directly to:

University Microfilm, Inc.
300 North Zeeb Road
Ann Arbor, Michigan 48106
A subsidiary of Xerox Corporation

In addition to Microfilm Copies available through University Microfilm, we have a limited number of regular back issues available. You may order these copies at \$1.00 each from:

Circulation Department
db—The Sound Engineering Magazine
980 Old Country Road
Plainview, New York 11803

Waters Attenuator

key to trouble-free mixing



With a complete line of professional audio attenuators, Waters Manufacturing has solved the noise problems usually encountered in conventional fader controls.

The answer is MystR®—Waters' proprietary conductive plastic resistance element. MystR's glass-hard, smooth wiping surface achieves noise levels below 20 μ V (at least 100 db down) over a trouble-free life of at least ten million operations. Precision engineered to provide professional "feel," Waters' attenuators also feature adjustable damping. Zero to 90 db of truly "stepless"

attenuation is achieved with Waters' computer-controlled curve-shaping technique which actually tailors the attenuator resistance element assuring superior tracking accuracy.

For your key to trouble-free mixing send for Waters' Audio Attenuator brochure which describes their complete line of linear and rotary attenuators and pan pots. Use the coupon provided, or better yet, phone 617-358-2777 for immediate service.



**WATERS
MANUFACTURING,
INC.**

Boston Post Road
Wayland, Ma. 01778

I'd like further information on Waters attenuators and MystR® conductive plastic elements.

- Send me your attenuator brochure and "The MystR Story"
- I need additional information:

Name _____

Position _____

Company _____ Phone _____

Street _____ City _____

State _____ Zip _____

Circle 21 on Reader Service Card

the 0 degree phase shift channel is just a straight amplifier, with no phase shift in it, or only those minimal amounts characteristic of modern feedback amplifiers—certainly nowhere near 90 degrees. So the natural assumption is that the other channel has some kind of network in it that produces a 90 degree phase shift, also plus or minus very few degrees, throughout the entire audio frequency range.

When or if somebody invents such a network, it will simplify a great many things. We remember, in the days of our youth, learning about using a 90 degree phase shift to produce two-phase from single phase, and then applying a Scott connection to the two-phase to produce standard three-phase. Even that, working at 60 Hz (or as it was, in England, 50 Hz) did not prove as easy the nice vector diagrams suggested. And any effort to work this process at more than one frequency at a time, such as 40 Hz and 60 Hz, was fraught with many difficulties. Imagine trying to do it from 20 Hz to 20,000 Hz!

So what do these phase shifting and combining networks do?

Of course, the networks that can shift phase and provide varying attenuation therewith are legion. I do not propose to discuss them all here. The most useful element derived from producing phase shift, without changing amplitude or attenuation, is one of the so-called "non-minimum phase," or "all-pass" networks.

The basic element for such a network can take the form shown in FIGURE 1. If the collector and emitter resistor are made equal, then the emitter signal will duplicate the base input signal voltage while the collector signal will be an exact phase inversion of the input voltage. We can do that as many times as we want, but all that buys us are as many reversals, or multiples of 180 degrees, we want. To get 90 degrees, or any other phase than multiples of 180 degrees, we need something else.

Connecting an R and C from emitter and collector, using values that do not materially load the collector and emitter signals, will produce an output signal, V_o , that rotates through 180 degrees with changing frequency, and at one particular frequency will shift precisely 90 degrees. This is the frequency where the reactance of the capacitor is equal to the resistance value.

At lower frequencies, V_o will couple more toward the emitter signal voltage. At higher frequencies, it will couple more toward the collector signal voltage. Over quite a wide frequency range, the output voltage, relative to

the input voltage, will swing through 180 degrees. And the nice feature of this arrangement is that the output voltage is always equal to the input voltage: it sweeps through 180 degrees without changing amplitude.

Of course, there are conditions to be met for that to happen, but they are relatively easy, with modern semiconductor devices—even using simple hi-beta transistors as shown here.

Now, if we cascade several such stages, with their operative frequency ranges staggered, we can have output rotate any multiple of 180 degrees that we may desire over the audio frequency range. Basically, each network will throw in its 180 degree phase shift while the others are doing very little, and then they will do their part.

Suppose we have one network that produces a 90 degree shift at 1000 Hz, connected between networks whose 90 degree points are at 125 Hz and 8000 Hz, respectively. At 1000 Hz, the 8000 Hz network will produce about an 11 degree shift, while the 125 Hz network will already have produced all but 11 degrees of its 180 degree shift. So they will add up to 180 degrees total, and the 1000 Hz network will produce 90 degrees, making a total at this point of 270 degrees shift.

Now, we have spaced those networks on frequency centers that are 8:1 apart. So if we design another network with its frequency centers also 8:1 apart but positioned so that they hit the geometric means between the frequencies of this network, then the centers will produce a 90 degree shift at frequencies midway between the frequencies where this one does, on a logarithmic frequency scale.

If we see what the adjoining networks on the second network do, at 1000 Hz (also shown in FIGURE 2), one centered at 353.5 Hz will have gone beyond 90 degrees to about 141 degrees, and the one centered at 2828 Hz will have reached only about 39 degrees, which again adds up to 180 degrees. So at 1000 Hz, the first network has a 270 degree phase shift, while the second has a 180 degree phase shift.

FIGURE 3 shows what we do to get a 90 degree difference in output phase, over a wide range of frequencies. We have one set of networks with center frequencies 10 Hz, 125 Hz, 1000 Hz and 8000 Hz, and another set, for the other channel, with center frequencies 44 Hz, 352 Hz, 2816 Hz and 35,200 Hz (to use round numbers).

Each set of networks maintains the 8:1 successive spacing until the ends, where there is not another network in the opposite channel on the other

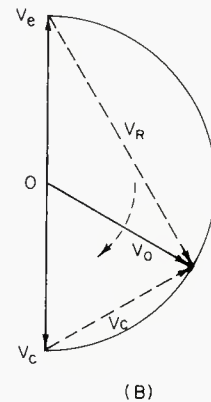
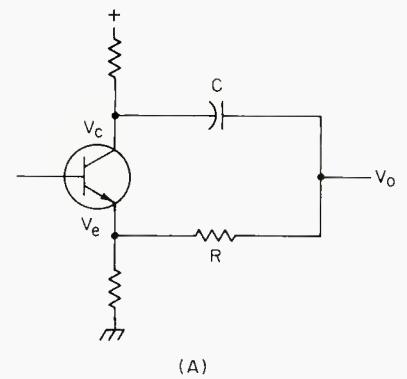

Figure 1. A basic network A), and its vector diagram (B), showing how progressive phase shift, from 0 degrees to 180 degrees, can be achieved without change in amplitude.

side of it. At the ends, the spacing is increased to 12.5:1, to maintain the 90 degree spacing a little further.

Looking at 125 Hz, the first channel, which has one network already nearly 180 degrees, one at 90 degrees, and one just starting, the total phase shift is 270 degrees. The second channel has one network at about 141 degrees, and another at about 39 degrees, producing 180 degrees total: a difference of 90 degrees from the first channel.

Now look at 352 Hz. The first channel has one network already very close to 180 degrees, one at about 141 degrees and one at about 39 degrees (and a fourth just beginning to move). This adds up to a total of 360 degrees. The second channel has one network up to 169 degrees, one at 90 degrees, and another at 11 degrees, adding up to 270 degrees. Again, a difference of 90 degrees.

Now look at 1000 Hz: The first channel has two networks almost to 180 degrees and one at 90 degrees, one just getting started, to balance the deficiency from 180 degrees on the network that has not quite got there. This makes 450 degrees. The second channel has two networks,

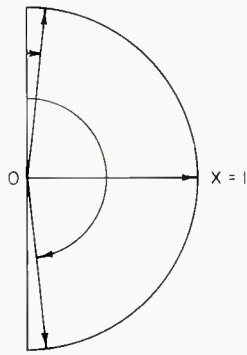

(A)

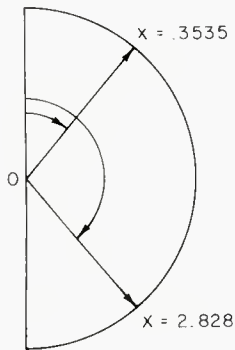

(B)

Figure 2. Combining the effect of successive networks. At (A), when a network in one channel has adjoining networks that are approaching 180 degrees or just leaving 0 degrees, the total is an odd multiple of 90 degrees. At (B), when two networks straddle the 90 degrees symmetrically, the total is 180 degrees or some multiple of 180 degrees, so the total is an even multiple of 90 degrees. The difference will always be 90 degrees.

one close to 180 degrees and the next at about 141 degrees, then two more, one at 39 degrees and the other barely starting to shift. The total is 360 degrees. Again, 450 degrees - 360 degrees = 90 degrees.

If you want to verify the same thing at 2828 Hz (or 2816, using our second set of figures) you will find that the phase shifts are 540 degrees and 450 degrees respectively.

What you really should notice is that, with four networks in each channel, both of them rotate through a total of 720 degrees. The difference of 90 degrees that is achieved through the working audio range, is only because one has moved 90 degrees further at all times than the other. Neither of them has zero phase shift anywhere within the audio range.

Choice of the 8:1 ratio is designed to optimize the adherence to 90 degrees between the frequencies at



Because people and their professions are many and varied... so are Telex headphones.

Telex makes many headphones for many kinds of people. From sportscasters and pilots to ham radio operators and those who simply enjoy listening.

Telex headphones range from featherweight units ideally suited for dictation, transcription, private radio and TV listening, to professional communications models featuring boom mics, and audio-metric-type transducers impervious to temperature and humidity changes.

We make two series of professional models to meet your needs... Series 1325 for stereo monitoring and Series 1320 for communications, with optional noise-cancelling boom microphones.

General purpose headphones include the Telex Announcers Earset®—inconspicuous for 'on camera' work and prac-

tically the standard of the industry—and the Teleset®, Twinset® and Earset® headphones for lightweight, comfortable and inexpensive private monitoring.

In all, there's a Telex headphone to match both your communications requirement, and your budget. For proof, write Telex Communications, Inc., 9600 Aldrich Avenue South, Minneapolis, Minnesota 55420.

PRODUCTS OF SOUND RESEARCH
TELEX
 COMMUNICATIONS, INC.

CANADA: Double Diamond Electronics Ltd., Scarborough, Ontario

INTERNATIONAL: Telex Export Dept., 9600 Aldrich Avenue South, Minneapolis, Minn. 55420 U.S.A.

7312

Figure 3. A composite diagram of the phase shift characteristics of successive networks in two channels, arranged to produce a 90 degree difference in output through virtually all of the audio range. Phase responses of individual networks in first channel at top, second network at bottom. The combination in each rotates through 720 degrees, but displaced by 90 degrees over the audio range.

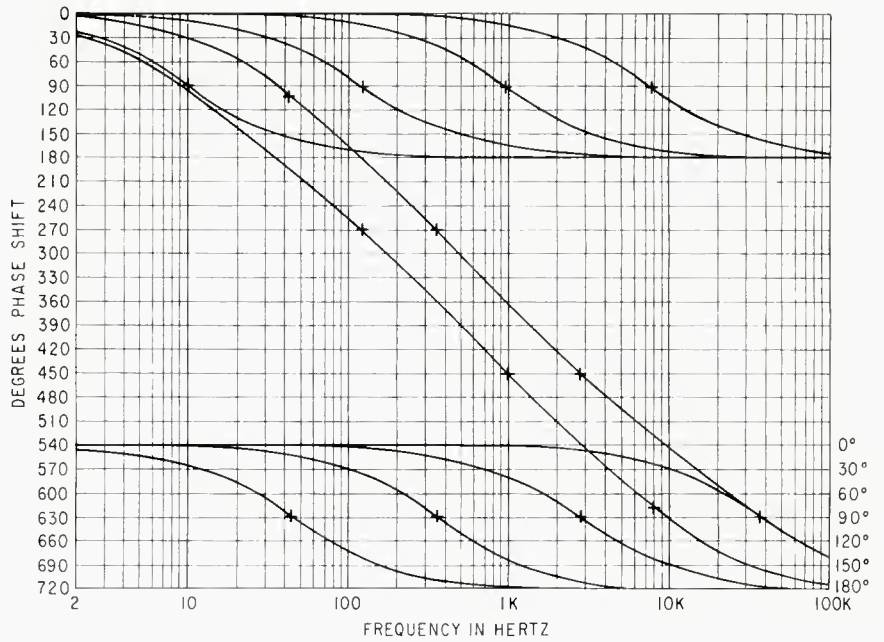

which the networks alternately center. For this to happen, the combined rate of phase shift, when adjoining networks in the other channel are, in this case, at 39 degrees and 141 degrees, must add up to the same rate produced by the one network just going through 90 degrees in this channel.

We have used approximate fre-

quencies, based on a theoretical ideal that postulates networks that go on indefinitely, with one correction for the fact that they do not. To get more accurate determination of center frequencies so that the 90 degree difference is more accurately maintained, a complete mathematical solution may be obtained on the above basis.

In FIGURE 3, we have shown the response of individual networks in channel one at the top, and of individual networks in channel two at the bottom, with the sloping lines showing how they combine between. Of course the networks cannot keep a perfect 90 degree spacing, but they do very well, except near the extremes of the audio range. ■

Eventide

the next step



NEW FEATURES

- DELAY DOUBLING
- NORMAL/LIMIT INDICATOR
- RECIRCULATION
- LED READOUT of DELAY TIME
- QUIET OPTICAL SWITCHING

DDL 1745A

from \$3600
(2 outputs
to 99 ms.)

EVENTIDE CLOCKWORKS, INC. — 265 WEST 54TH STREET, NEW YORK CITY, 10019 — (212) 581-9138

Circle 25 on Reader Service Card

SOUND WITH IMAGES

● Many conventions are rather general in respect to the people they are aimed at although they are quite specific in subject or equipment. Some others are specific in their aims but general in the exhibits. Another type is specialized in both target and subject.

The latter description fits the conference held at the South Beach Psychiatric Center, Staten Island, N.Y. on November 1-3. The International Continuing Education Institute sponsored the meeting whose subject was *The Basics of Video in Psychiatric Training and Treatment*. The setting was in a relatively new building complex on the least developed, commercially, borough of the city, whose approaches include the longest suspension bridge in the world, or a short ferry ride past the Statue of Liberty and the skyline of New York—for 10 cents, round trip.

The first day of the convention, in addition to the usual check-in procedures, included a tour of the Center, a display of the video equipment which would be demonstrated to the visitors, group discussions and “hands-on” experiences with the equipment, and a discussion on *Self-Image Confrontations*.

For the next two days, sessions covered various subjects in psychiatry including among others, *Video to Teach Basic Clinical Skills to Mental Health Patients*, *Playback Confrontations With Alcoholics*, *Video Replay in Transactional Analysis*, *Making Use of Available Audio/Visuals*, and *The Cameraman's Culture and Training as a Determinant in Video and Film Making*.

A most interesting session was held

in the auditorium in the afternoon of the first day. On the stage, casually seated in easy chairs or on a sofa or on the edge of the stage, were some faculty members of various psychiatric centers, representatives of hardware manufacturers, and A/V specialists. About 400 or more people involved with psychiatry and video listened to the experts talk about the use of hardware in various phases of treatment, type of equipment used, special requirements such as one-way observation glass, and inexpensive split-image devices.

Four cameras and a hand-held portable unit were used to provide the audience with close-ups of the speakers both on stage and in the audience during question and answer periods. A Dage mixer board was used to feed the video to four large screen video monitors in the audience, two on stage for the participants, and six small units at the control area. Sound pickup from lavaliers might have been a bit better, but the wireless intercom between control and cameras and stage directors must have worked fine as everything seemed to be under fairly good control.

Some of the equipment discussed were low-light cameras to work from behind one-way glass, which has a great capacity to reduce light passing through it, split-image devices so that the doctor can watch his patients on one monitor and the questioners on the other, with both conversations recorded on a video tape for later playback. Some tricks mentioned included using a mirror mounted on a board placed directly in front of the camera lens to make an inexpensive image splitter, facing the panning arm to-

ward the front of the camera instead of to the rear, as is normally done. In this way, the doctor can control the panning of the camera over his shoulder and thus avoid getting the camera between him and the patients. One doctor's preference is to use cameras without viewfinders so that he does not have to look into the back of the camera rather than at the patients (he sees what he is aiming at in a small monitor located behind the patients). Another trick involves disconnecting the tally light to prevent the patients from knowing when they are “on camera” when the camera is in the room. Some technical information on vidicon and tibicon cameras was also passed on to the audience.

Following this session, each of the manufacturers was located in a separate room so that visitors could check equipment at close hand and ask questions of the representatives. One such room was for use by Adwar Video, who demonstrated the new Akai hand-held color camera with automatic and manual iris control, a 1.5 inch viewfinder, and a 525 line 2:1 scanning system, and which weighed less than six pounds. Additional demonstrations were by Sony, Windsor Total Video, and others.

The second convention we would like to tell you about in this coverage took place on November 29th at the Roosevelt Hotel in New York City. Sponsored by *Audio-Visual Communications* magazine and the National Visual Communications Association, *A Day of Visuals* was aimed “at all who are engaged in or who use audio-visual communications to achieve organizational goals.” Well over one hundred people attended to find out about novel ways to make use of familiar audio-visual equipment, new technologies, and to hear experts from various fields discuss the application of audio-visual techniques to meet managerial and organizational requirements. Among those who attended were producers, directors, and writers of audio-visual programs, managers, technicians, designers, speakers, planners and executives, and many from other fields, all of whom have to keep up with the latest in the use of audio-visuals.

For those not familiar with the sponsors, the magazine *Audio-Visual Communications* is published monthly by United Business Publications, Inc., and the NVCA is a non-profit professional and scientific organization for the advancement of visual communications in business, education, industry, and government. Since 1952, when the organization was founded, it has sponsored an annual awards compe-

tion as a means of gaining recognition for outstanding examples of visual presentations and to provide incentive for the creation of better visual communications in the future. At this, the 19th annual "Day of Visuals," the announcement of the winners and the presentation of the awards was scheduled for the banquet held in the evening.

The day opened with a greeting by Mr. Jim Watkins, publisher of *A-V Communications*, and an overview of the day's proceedings by Mr. Les Waddington, consulting editor to *AVC Magazine*. With the use of slides and tape (sound distribution system by Philips, tape machine by Sony) in 4-track, Mr. Waddington introduced the speakers of the session, and each in turn gave a brief teaser to the main talk to come later.

The first speaker was Mr. Joe Naas, president of Cellomatic Productions. It must be stated here that each main speaker had been requested to keep the talks on an informational level with no reference to the commercialism possible when discussing a product or service offered by the company. Mr. Naas did just that in showing how his company's development of a new overhead projector was adaptable to industrial presentations although it had been originally designed, and used

extensively, for news media. The device, shown in this meeting on the rear screen projection screen used for all other visuals, provided interesting effects possible by use of two transparencies (side-by-side) and various controls. Overlap, dissolve, horizontal wipe, vertical wipe, line-by-line addition or subtraction of written material, and other unique techniques for overhead projection were demonstrated. The machine has the capability of being operated by remote control, requires a bit of training and practice for most effective results, and needs only the desire for more interesting overhead presentations to make it most useful.

It was not until the question and answer period following the talk that commercialism sneaked into the meeting. Questions on the cost (about \$17,000) and the training of the operator (quite extensive for greatest capability) were answered, but attempts were made throughout to maintain all discussion on the information/application level.

The speakers who followed during the morning were Mr. Bill Amos, manager of marketing development, video products for Sony, who spoke on the state-of-the-art of Videocassettes; and Mr. Mark Foster, president of Microband National Systems

on the topic of *Transmission Systems and Multipoint Distribution*.

According to the information from Microband, the distribution system will make possible "hundreds of private, low-cost, full color television networks" and will operate anywhere in the country. The present plans call for intercity hookups to be made by video tape or existing long-lines, but future plans call for microwave and satellite facilities. MDS (Multipoint Distribution Systems) is a regulated common-carrier telecommunications service authorized by the FCC in 1970. It cannot provide its own program material, but can only transmit what is provided by the customer.

Microband will furnish studio facilities and a transmitter to send programs to parabolic antennae located anywhere in a 360 degree pattern up to 25 miles away, depending, of course, on the local terrain and the height of the transmitting antenna. Programs can be either on video tape or film. The material is converted up to 2150 MegaHz. and is received on antennae between one foot and six feet in diameter depending on the distance from the transmitter. The signal is then converted to a preselected unused channel on a standard t.v. set. Privacy of operation is maintained by an encoder/decoder arrangement so

OUR LAST REVERB WAS A BARGAIN. THE NEW ONE'S FRANKLY A STEAL.

Our model 105C gave you \$1000 sound for \$595. We haven't changed any of that in the new one.

But we have increased input sensitivity to make it more versatile. In fact, it's compatible with virtually any system.

We added an equalizer that can provide variable peak boost at any one of four frequencies.

We designed the 106C to go anywhere you want it to—the spring locks instantly

for travel and an optional portable case is available.

And we left the price alone.

That's the way we do business at Orban/Parasound—we offer products like our new 106C Spring Reverb and our new Dynamic Sibilance Controller with the best price/performance ratio in the industry today. For more information contact your local Orban/Parasound distributor or write us directly.

ORBAN/PARASOUND MODEL 106C SPRING REVERB \$595...STILL.

680 Beach Street, Suite 495, San Francisco, California 94109. (415) 776-2808

that only those antennae with the proper decoder will pick up the proper encoder. Further encoding is also positive at the pickup location to keep unwanted receivers from getting the material being sent out.

At lunch, Richard Nader showed clips from his movie *Let The Good Times Roll* and discussed the various special effects techniques used in the creation of portions of the film. After lunch, the afternoon was filled with four split sessions. In the first pair, Roslyn Bremer, Director of Communi-Vu, New York, discussed the preparation and technique for making written words come alive in oral presentations, while Karl Parshall, Manager of the A/V art department of J.C. Penney Co., talked about the creation and production of professional visuals for a large in-house production facility.

Mr. Paul Caravatt, chairman of Caravatt, Kleinman, Inc., discussed how to assess and meet organizational needs and technologies, while Mr. Bob Ruthman, president of Communications Specialists, told how to create the concept and script for an A/V presentation. Mr. Douglas Gratton, president of Gratton Associates, talked about a basic approach to staffing and directing for video and film production, and Maximillian Kerr, president of Maxi-

millian Kerr Associates, took the subject *A Slide Studio in a Package* and talked about a coordinated system and professional in-house production techniques.

The final split session had Mr. Jon S. Putnam of the J. C. Penney Co. discuss guidelines for managing and budgeting for an in-house A/V facility, while Mr. John McConnell, manager of the Philips Broadcast Corp.'s Electro Acoustical Consulting Service, talked about microphone differences and uses and the proper selection for specific applications. The final portion of the afternoon's sessions was a film on *Image Generating Equipment and Computer Generated Graphics for Slide Presentation* presented by Chris Carver, manager of marketing of the G.E. Co.'s Kinegraphics department. Mr. Waddington, who gave the morning's overview, then wrapped up the entire day.

Two separate conventions, each stressing its own form of visual, each disseminating a fund of knowledge for those interested in keeping up with what was going on in the field of audio-visual-video information. Hopefully, each of you will attend a session of particular interest to you in the near future. We would like to hear from you about your impressions for the benefit of others. ■

you write it

Many readers do not realize that they can also be writers for *db*. We are always seeking good, meaningful articles of any length. The subject matter can cover almost anything of interest and value to audio professionals.

Are you doing something original or unusual in your work? Your fellow audio pros might want to know about it. (It's easy to tell your story in *db*.)

You don't have to be an experienced writer to be published. But you do need the ability to express your idea fully, with adequate detail and information. Our editors will polish the story for you. We suggest you first submit an outline so that we can work with you in the development of the article.

You also don't have to be an artist, we'll re-do all drawings. This means we do need sufficient detail in your rough drawing or schematic so that our artists will understand what you want.

It can be prestigious to be published and it can be profitable too. All articles accepted for publication are purchased. You won't retire on our scale, but it can make a nice extra sum for that special occasion.

noɹnbnoɹɹ

LOOK AT IT THIS WAY.

“Grandson”

will help make an impact on your listeners and your profits using proven multi-track production techniques. We guarantee you'll love GRANDSON'S new production results and unique versatility. Where else can you find an affordable, fully modular, professional recording / production console with 54 inputs—18 mixing positions—and on-air capability?

Ask us about GRANDSON today.



auditronics, inc.

P.O. Box 12637 / Memphis, Tenn. 38112 / 901/276-6338

The world leader in recording consoles at sensible prices.

Circle 28 on Reader Service Card

NEW PRODUCTS AND SERVICES

BROADCAST AUDIO CONSOLES

● A new line of six-, eight-, and ten-channel consoles are available in mono, dual mono, and stereo versions. The units encompass the following features: step type, silver contact faders; four switchable inputs per fader, user adjustable for mic or high level; lever key switches; etched and filled front panel markings; four muting relays with programming board for feedback-free origination from four locations; high gain 104 dB micro-program output; shielded PC mixing bus; total noise, hum and crosstalk 68 dB below +18 dBm output with -50 dBm equivalent power microphone input; ten watt electronic dissipation limited monitor amplifier completely protected from shorts and overloads; built-in cue/talkback system; built-in headphone amplifier. Lower cost four-channel units and special configurations for television, catv and cctv available.

Mfr: Ampro Corp.

Price: \$1595-\$3,695.

Circle 33 on Reader Service Card

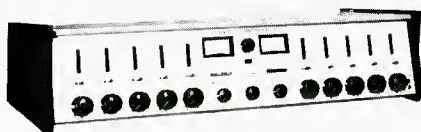

PROFESSIONAL CAMERA AND ACCESSORIES



● Four new sound super 8 products, designed for professional use, have been announced by this manufacturer. These include a single-system sound super 8 camera, a 200-foot capacity sound super 8 cartridge for magnetic prestripped super 8 film, a new super 8 Ektachrome™ film, and a compact, automated super 8 film processor. The camera, an existing-light, single-system unit, runs at 18 and 24 frames per second with 18-frame separation. Features include acceptance of 50-foot and 200-foot cartridges, manual and automatic exposure control, automatic gain control in sound recording with an alternate microphone input providing a 10-dB reduction in amplifier pickup to reduce ambient noise, and manual zoom control. The film cartridge can be used for silent or sound film. The film, available in 50-foot and 200-foot cartridges, has ASA speeds of daylight (with a type A filter) 100 and tungsten: 160. The automated film processor has automatic replenishment, self-contained replenisher mix and storage tanks, and is cartridge-loading. It operates at ten feet per minute, with a process time of 8½ minutes.

Mfr: Eastman Kodak Company

Circle 35 on Reader Service Card

THREE WAY AUDIO SWITCHER

● TMS-1W tape recorder selector switch has inputs for three tape recorders or other line level sources, permitting three recorders to be used simultaneously for recording, copying, editing, etc. It can also be used to interface graphic equalizers, noise reduction units, synthesizers and other signal processing equipment. Use of the unit eliminates the hooking and unhooking of audio cables usually necessary when switching hi fi equipment in and out, since it connects into the tape monitoring facilities of a stereo preamp, amplifier, or receiver directly. If greater interconnection flexibility is desired, two of the TMS-1W switchers may be connected in series.

Mfr: Russound/FMP

Price: \$32.95.

Circle 34 on Reader Service Card

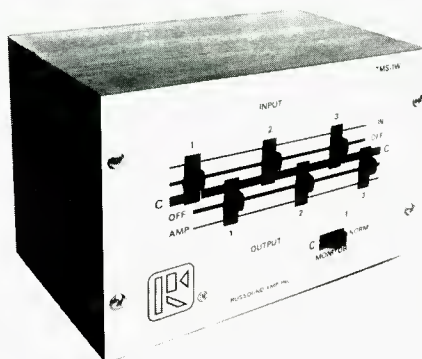

QUADRIPHONIC ENCODER

● An encoder/mixer, model SAE-2000, has been introduced to enable f.m. broadcasting stations to produce local four-channel live programs and to transmit four-channel tapes with an authentic *surround* sound. The SQE-2000 features accurate phase characteristics and frequency response; basic SQ encoding plus exterior-, forward-, and back-oriented encoding for special quadriphonic effect; four line inputs for broadcasting four-channel tapes and other four-channel programs; four microphone jacks for low-impedance microphone inputs; stereo mixing through double four-channel linear potentiometers; stereo headphone monitoring of front, back, or mixed front-and-back sound. It can be operated optionally from 117V electric lines or 12V battery power for remote pickup. Response extends to 15 kHz.

Mfr: CBS/Sony (Special arrangement)
Price: \$695.

Circle 38 on Reader Service Card



BALL POINT SINGLE-D CARDIOID MICROPHONE

● New head and diaphragm designs on model 671 offer improved pickup of low frequencies in close-up applications and the minimizing of off-axis coloration. The manufacturer claims exceptionally wide linear response at all angles of incidence for high gain-before-feedback in sound reinforcement applications. The head assembly, which can be replaced by the user, features a newly designed shock absorber which isolates the transducer assembly from mechanical noises. An Acoustifoam filter improves close talking and shields the diaphragm from dirt and magnetic particles.

Mfr: Electro-Voice

Price: \$54.75

Circle 37 on Reader Service Card



FREQUENCY ACTIVE EQUALIZER

● Control settings which can be observed with peripheral vision from any angle or distance are features of model 714 plug-in fifteen frequency active equalizer. The device incorporates linear motion slide controls and high performance integrated circuitry. Portable units, designated 714-4 and 714-8, serving four or eight channels, can be used in conjunction with 714. These have internal power supply and input/output connectors. All units are transformerless.

Mfr: Clover Systems

Circle 36 on Reader Service Card

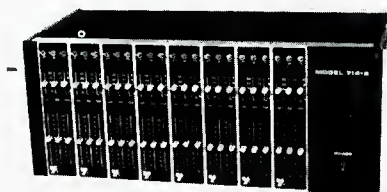

MINIATURE AMPLIFIER MODULES

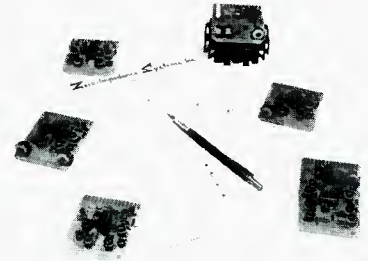

● A wide range of amplifier configurations is offered in this line of miniature plug-in printed circuit card amplifiers. They handle such functions as balanced input microphone preamps, equalization amps, mix amps (active combining networks), line amps, power amps, and electronically balanced input and output, user programmable amps can be obtained in a single amp or dual amp format.

Mfr: Zero-impedance Systems, Inc.

Price: \$30.00 per amplifier function.

Circle 39 on Reader Service Card



WORAM AUDIO ASSOCIATES

Consultants in Studio Systems
Engineering, Design and Installation

—offering—

A COMPLETE CONSULTATION
SERVICE FOR STUDIO
PLANNING AND
CONSTRUCTION

FREE-LANCE RECORDING
SERVICE IN THE
NEW YORK AREA

212 673-9110
64 University Place
New York, N.Y. 10003

THREE-WAY STANDING SPEAKER

● A recently developed omni-directional wave transmission line tweeter covering the frequency spectrum from 5 kHz to 21 kHz is featured in model 2000 AXT speaker, successor to 2000 A. 2000 AXT, which utilizes three all new drive components, has a 4.5 inch midrange. The 12 inch transmission line woofer is treated with special stiffening and damping materials to provide five times the stiffness to mass ratio of other drivers, eliminating most distortion emitted from different parts of the cones at different instances of time. 2000 AXT offers about 6 dB more efficiency than the discontinued 2000 A.

Mfr: Infinity

Price: \$299.00

Circle 30 on Reader Service Card

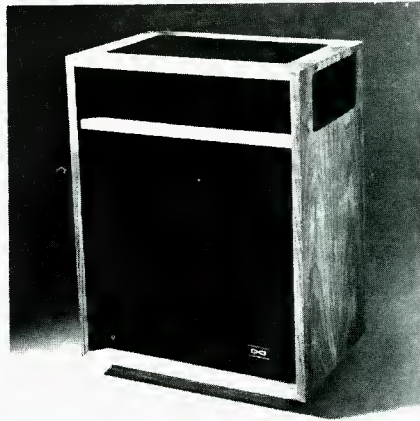

REPLACEMENT TAPE ELECTRONICS

● Single-channel recorders may be upgraded through the installation of model 360 tape recording electronics, designed as a plug-for-plug replacement package for Ampex 300, 350/351, and 354 tape transports, as well as most other single-channel tape transports and head assemblies. It will perform with the original heads. Completely self-contained, model 360 has a fully regulated internal power supply adaptable to wide variations in line voltage, plug-in circuit cards, and solid-state design. Panel controls, all accessible from the front, include record gain and repro gain with preset cal positions and solid-state monitor and equalization switching to eliminate contact noise and to permit remote control of both these functions.

Mfr: Inovonics Inc.

Price: \$645

Circle 31 on Reader Service Card

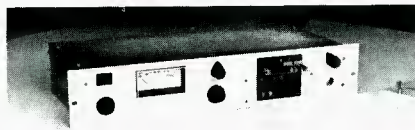

AUDIO INTERFACE

● The problems of low audio level and unbalanced output of 1/2 inch tape helical scan video recorders are approached by model AO-12 output interface, which has a volume control boosting the 1/10th volt EIAJ-type recorder/player output or similar source to +8dBm at 600 ohms, balanced, broadcast standard for connection via patchcord to studio facilities, mixer-amplifiers, and to other vtrs for dubbing. Simultaneous feed to various lo-z and hi-z loads is made possible. Companion AI-12 input interface bridges 600 ohm broadcast lines and connects to EIAJ vtr input.

Mfr: Ultra Audio Products

Price: AO-12: \$125; AI-12: \$75.

Circle 32 on Reader Service Card

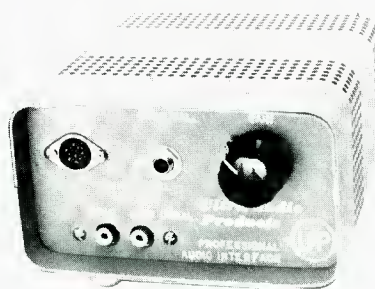

FOUR-CHANNEL TAPE DECK



● A six-pole special induction motor, used for reel drive, which precisely monitors tape tension, is one of the luxury features of RT-1020L four-channel professional three-motor, three-head stereo tape deck, servicing 10 1/2 inch reels. A motor-flywheel combination, using a 4/8 pole two-speed hysteresis synchronous motor for driving the capstan insures constant speed regardless of line voltage fluctuations. Further control of tape tension is offered by a back tension changing switch which lets the user adjust torque characteristics according to tape reel size and prevents dropouts. The three heads consist of the four-channel in-line head, a two-channel type and a recording head with a balance hyperbolic design. The playback pre-amplifier is a three-stage direct-coupled type with a dynamic range of more than 20 dB from 0 vu. The recording amplifiers, independent for line input signals and microphone input signals, can be used with a 600-ohm professional microphone with more than 50 dB dynamic range. The equalizer amplifier has a fet equipped switch for the recording side, adjusted to the equalization characteristics of tape speed; amplifiers have a three-position bias circuit equipped with a timing relay to suppress head magnetization. Operational buttons are the mechanical locked type.

Mfr: U.S. Pioneer Electronics Corp.

Price: \$599.95

Circle 68 on Reader Service Card.

AUTOMATIC CARTRIDGE AND CASSETTE LOADERS

● A series of five models of loaders is offered, designed to provide precision winding capabilities at low cost. All models give tape length measuring, tone sense, and winding speed options, ranging from 30 ips to 60 ips. The ACL-25 series for blank tape loading features a digital control panel to set tape length exactly at 30 ips winding speed and a one-button reset/run for fast operation. The ACL-60 series offers blank tape loading, tone detection or the combination of tone and blank options in one machine at 60 ips winding speed. All models have torsion control for proper tape pack and winding of various hub sizes, utilizing TTL digital control circuitry. The ACL-60 series will accept up to 14-inch pancakes as standard. (This is optional on ACL-25.)

Mfr: Ramko Research

Price: ACL-25—\$159;

ACL-60—to \$350.

Circle 40 on Reader Service Card

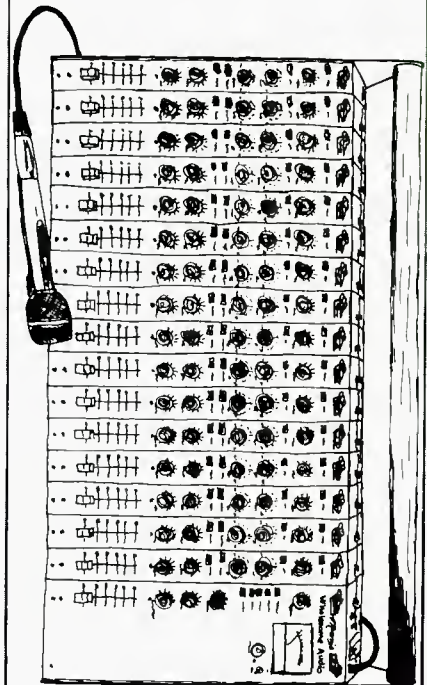

HIGH POWERED AMPLIFIER

● High-powered amplifier, model 700B offers 350+ continuous watts/channel power output. Distortion readings are less than 0.02 per cent. It can be operated in either direct coupled or normal mode and comes with carrying handles, individual level controls, meter attenuation for monitoring of power output at low levels.

Mfr: Phase Linear.

Price: \$799.

Circle 41 on Reader Service Card

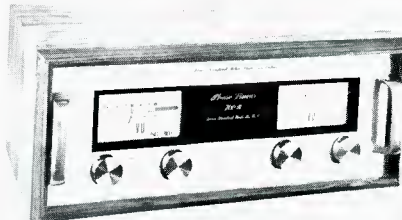

DUAL CUE RECORDER CONTROL

● Pre-set and automatic location of desired tape parking points are improvements on BE 460 dual cue controller, designed to be used with BE 450 wide range synchronizer, which provides individual or simultaneous automatic cueing of two video or audio tape recorders. The system works on quad or slant-track video tapes and sprocketed or unsprocketed audio. It provides exact synchronization or exact front-panel controlled offset of two recorders from any starting point within a thirty second capture range. BE 460 cue controller replaces the manufacturer's BE 420 code reader, which required manual pre-roll parking of recorders.

Mfr: EECO

Circle 73 on Reader Service Card.



CALL: BILL,
STEVE, OR
ED AT ~



GATELY ELECTRONICS
57 W. HILLCREST AVE.
HAVERTOWN, PA. 19083 (215)-449-6400

PROUDLY PRESENTS THE MIXER. THE WORLD'S ONLY PROFESSIONAL SOUND REINFORCEMENT MIXING CONSOLE. \$2243.00 FOR 16 INPUTS! (MAIN FRAME \$499, INPUT BR.#109) A FEW IMPORTANT FEATURES:

- QUIET!!!
- MODULAR
- BALANCED IN & OUT
- LOW FILTER EQ ± 15db @ 50Hz
- HI FREQ. EQ. ± 15db @ 12KHz
- + 20 TO -70 dbw INPUT CAPABILITY
- SOLO SYSTEM



Monopod WHOLESALE AUDIO



Incremental Optical Encoders

Here's a thoroughly thought-provoking article that will set many readers working in the directions indicated. Our judgment is that this can get you far!

WOULD you like to have noiseless faders in your console? Perfectly tracking stereo and quad master controls? Coca cola-proof pan pots? And, would you like these perfect and noiseless controls to remain that way year after year with no cleaning and no routing or preventative maintenance? You can have such controls, along with several bonus features sure to come in handy when automation becomes more prevalent. Just grab yourself a handful of *incremental optical encoders* and plug 'em in your board.

A handful of what?

Incremental optical encoders!

What?

Well, you take this piece of plastic, and put a few lines on it and put an led on one side and a couple of photo-transistors on the other, couple them to a Schmitt trigger and precedence detector, followed by a binary up-down counter and . . .

Start from the beginning.

OK.

The problem with faders, pots, switches, and almost all devices designed for human activation is that they are mechanical. A switch has two contacts of metal that must

come into precise contact with each other at the appropriate time. If there is a chemical film or dust on the contacts, the switch is likely to be noisy. A pot has the same problem. A metal slider is in contact with some resistive material and the friction produced by multiple operations, combined with environmental hazards such as air pollution, cigarette smoke, beer foam, etc. can cause the resistance to vary in a random fashion in addition to the desired one. This random resistance variation is—you guessed it—NOISE. Ladder attenuators such as used in most consoles do not suffer from this particular problem, but rather from the one ascribed to switches. A ladder attenuator is composed of a wiper sequentially contacting metal terminals. If one of these contacts is corroded, contaminated, or critical to a mix, it will generate *noise*. Most failures in switches and switch-type ladder attenuators are non-catastrophic in the sense that cleaning can usually restore them to usefulness. However, even ignoring the motto "Cleanliness is next to impossible," there comes a time in the life of every attenuator when it must be sent to the scrap bin.

The obvious solution is to make controls non-mechanical in nature. This is easier said than done. After all, you can't direct thoughts at an attenuator and expect it to obey (although they're working on that). There are some materials that exhibit resistance change with pressure, but these are impractical for the obvious reason that pressure must be maintained to retain the desired control action. There are body capacitance operated devices, which have been used to advantage in such applications as signal dele-

gation and monitor select switches. These switches however, are binary in nature, *i.e.* on or off, and cannot be used to control continuous functions such as amplitude and position.

What is needed is a control whose physical operation is similar to that of common controls, but whose electronic operation is independent of gross physical phenomena. One such device is the *incremental optical encoder* (known interchangeably as a *shaft encoder*). This device consists of a mechanical shaft which has a knob on the human end and a slotted disc or photographic negative on the other end. This disc rotates along with the knob, and the slots or opaque areas interrupt a beam of light. By a simple scheme to be described, it is possible to determine both the direction and amount of rotation and store this as a digital number or convert it to an analog function such as voltage or amplitude. By its very nature, a control that operates in steps does not have almost "infinite resolution," as does a variable resistor. However, in most applications, the resolution is sufficient. It is possible to obtain resolution of a hundred or so steps with simple home-made or cheaply obtained parts, and units are available commercially with thousands of steps per revolution. A hundred steps are far more than ladder attenuators have, so an encoder type of control gives better resolution, and the steps are much less noticeable when attenuating a signal source such as an oscillator or an electronic organ.

Since there are no mechanical stops or detents, the encoder can rotate through a full 360 degrees, and more. If extremely fine control is desired, 10, 100 or more rotations of the encoder can be employed to give a wide range in very fine steps. One company, Hewlett-Packard, uses such a control on a frequency synthesizer to give 1 Hz steps over a range of many mHz. Since we are audio people, we are dealing with the sensitivity of the ear, and must improve upon that by half an order of magnitude or so in order that the control does not degrade other aspects of the system.

Before going into detail on the applications of the encoder, let's describe the construction of a unit. There is no reason why the experimentally inclined engineer cannot build one for himself by following this description.

THEORY OF OPERATION

We start out with a circular photographic negative around whose periphery are evenly spaced alternations of clear and opaque area. (This negative should be obtained from computer-generated artwork. Hand made artwork requires lots of time and is incredibly tedious. (See insert for details on obtaining artwork.) This negative is mounted at its center on a shaft and bushing combination. The friction of the shaft and bushing should be concomitant with the desired control function—something that requires precise adjustment should have less freedom to turn than a multi-turn control whose range must be rapidly traversed. Weighting the shaft may improve the *feel* of the control. On one side of the negative, a light source, preferably a light emitting diode, is placed so that it shines through the negative. Directly opposite the light source is a phototransistor. Certain commercial devices are particularly desirable for this application. The G.E. H13B2 is a photo-interrupter module which has a focused infra-red led and phototransistor mounted in the same package and appropriately aligned. There is a space between the devices for the negative to be inserted. Best of all, the unit quantity price is under three dollars. One of these devices is sufficient to count the interruptions and thus determine the amount of rotation of the negative.

To determine the direction of rotation, another led phototransistor pair is placed around the negative and

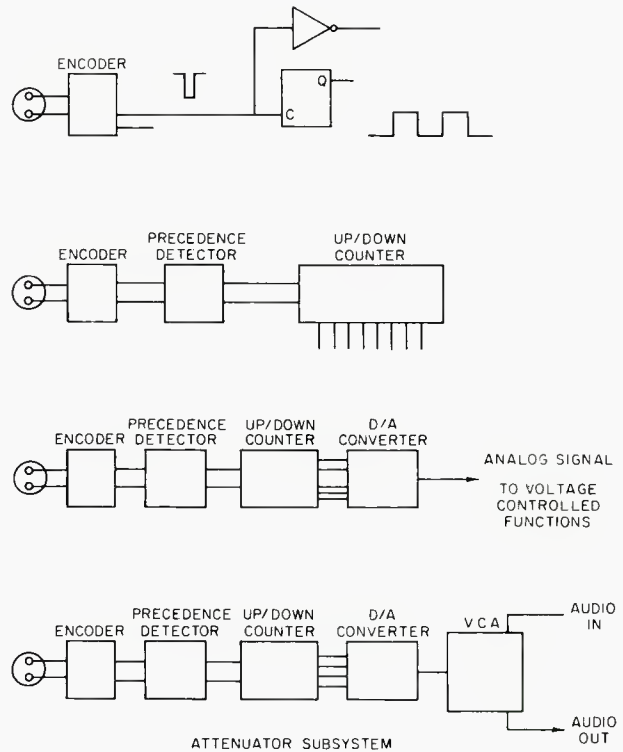

Figure 1. Block diagrams of several possible systems as described in the text.

spaced precisely from the first pair. The object of the spacing is to assure that when one phototransistor is centered over a clear segment, the other is positioned precisely on an edge. As the shaft is rotated, a square wave is produced, by each sensor, and the two square waves are out of phase by 90 degrees. If the shaft is rotated in one direction, one of the square waves has a negative to positive transition before the other. Reversing the direction of rotation changes the precedence of the transition. By detecting the precedence of the transitions the direction of rotation may be determined. By counting the number of transitions, the amount of rotation may be determined.

USES

The shaft encoder may be used alone, with a counter; with a counter and d/a converter; with a counter, d to a and vca; or with a whole system full of things. FIGURE 1 shows block diagrams of possible subsystems.

Starting with the encoder alone, it is possible to generate pulses (or square waves by dividing the output by two). The pulses are a convenient signal source for troubleshooting digital circuitry. Instead of a pulse train or a single pulse, which are the options offered by standard test instruments, you can generate a few pulses necessary to get the circuit to the proper state and then generate them, one at a time, either with a gentle turn of the encoder or with a button. Using an encoder to generate a square wave has merit for some unusual applications. For instance, how about a siren for live performance? Put a heavy knob on the encoder and give it a spin. Connect the output to a thousand watt amplifier. See the audience run!

The next step in complexity is to add an up/down counter, and if desired, a readout. Depending upon the up/down counter, either a binary or binary coded decimal reading may be obtained. The digital signals may then be used to activate relays or digital multiplexers which con-

Figure 2. The schematic of a phototransistor amplifier and precedence detector circuit for use with a shaft encoder.

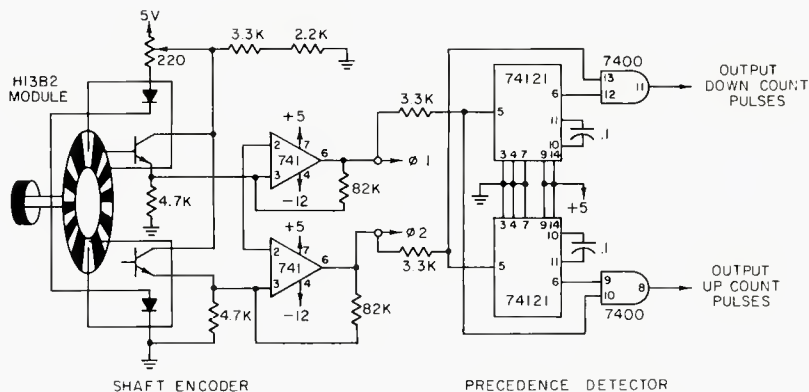

trol various circuit elements. One commercial application of this system is in the Eventide Digital Delay Line, in which an encoder is connected to a counter/readout, and the digital output also goes to a multiplexer which selects taps on the shift register chain, thus varying the delay. By turning the knob several times, 200 delay steps may be selected. An equivalent operation with switches would require 200 detents, or coarse and fine controls. The digital signals can also be used to switch relays or mosfets in series with, say, frequency determining components such as capacitors. Thus, a variable equalizer or oscillator can be built, having much better control accuracy and stability.

Finally, the encoder can be used with the up/down counter, readout, and digital-to-analog converter to perform any control function normally performed by a pot. The d-to-a converter is a device which accepts a binary input signal and converts it to an analog value. The accuracy and resolution of a d-to-a is defined by the number of *bits*. A six-bit converter, for instance would give 64 discrete output voltage steps. An eight-bit converter would give 256 steps. The resolution is 2^n steps, where n is the number of bits. As n increases, the component stability and accuracy requirements increase geometrically. An eight-bit converter can be built with readily available components or can be purchased in i.c. form for a few bucks from Motorola, Precision Monolithics, and others. For applications described herein, an eight bit unit will be adequate, since a control with 256 steps can cover over 120 dB in $\frac{1}{2}$ dB steps, which is far better than a ladder attenuator, and, for that matter, better than the ear's discrimination of amplitude steps. Most performance parameters of d-to-a converters do not concern us here. Since the encoder is a manually operated device, speed is irrelevant. Absolute accuracy likewise doesn't matter because the subsystem can be calibrated, relative to the system. In general, demands made on device parameters by audio system control functions are so far below the state-of-the-art that they may be effectively ignored as far as design is concerned. The variable d.c. voltage from the converter is applied to a voltage controlled amplifier, which actually varies the signal amplitude. This is the most critical part of the system as far as the sound is concerned.

The vca has been described in the literature and will not be discussed here except to say that units are offered by several manufacturers (dbx, Allison Research, among others) and variable gain i.c.s are available at low cost from RCA, Motorola, National Semiconductor, etc. The desired control function would be logarithmic, so that a constant percentage of attenuation is available per step of the control.

Everything so far has dealt with the *rotary* shaft encoder. The author is fully aware that *linear*, or slide faders, are the standard of the industry. The obvious thing to do is to convert rotary to linear by means of pulleys. This is easier than with a rotary pot since there is no critical slider friction to worry about. A rather more elegant solution is to make a linear encoder. This need be nothing more than a piece of plastic with alternating black and white stripes. The tolerances are not as critical since there is no requirement for uniformity around a complete circle. Of course, the advantages of multiple rotations for increased resolution are lost. Since the material employed for the negative can be flexible, one can build the device in little more length than the slide action plus the bending radius.

AUTOMATED ATTENUATOR: A PRACTICAL SUBSYSTEM

So far, our discussion has been theoretical. Let's consider the construction of a complete attenuator subsystem using the shaft encoder. It performs all the normal functions of an attenuator. It can also be made compatible with virtually any format computerized control or mixdown computer.

Specifically, it will have the following features:

1. Control audio level in $\frac{1}{2}$ dB steps over range, and "infinite" attenuation.
2. Have, if desired, a digital, led column, or other readout of the device gain or attenuation. This will indicate gain even when the system is remotely operated.
3. Have available at all times a digital code giving precise setting of control. This code may be sampled by a mixdown system and stored to permit automatic resetting.
4. Accept a digital input in the same format as (3) above to remotely control gain of system.
5. Allow "redefining" gain if desired so that the mechanical zero dB point on control can be at any gain. This can be done whether in manual or computer controlled mode.

Please keep in mind that this is *not* a construction article. First, the device to be described has not been built in prototype form and, although it will work, theoretically, there are always refinements which become apparent when working with something solid. Second, although logic types are given in the diagrams, pin connections are not shown, and no attempt has been made to minimize the circuitry necessary since this is a conceptual description and will be clearer if circuits are grouped and self-explanatory.

Observing the schematic of the proposed system (Fig-

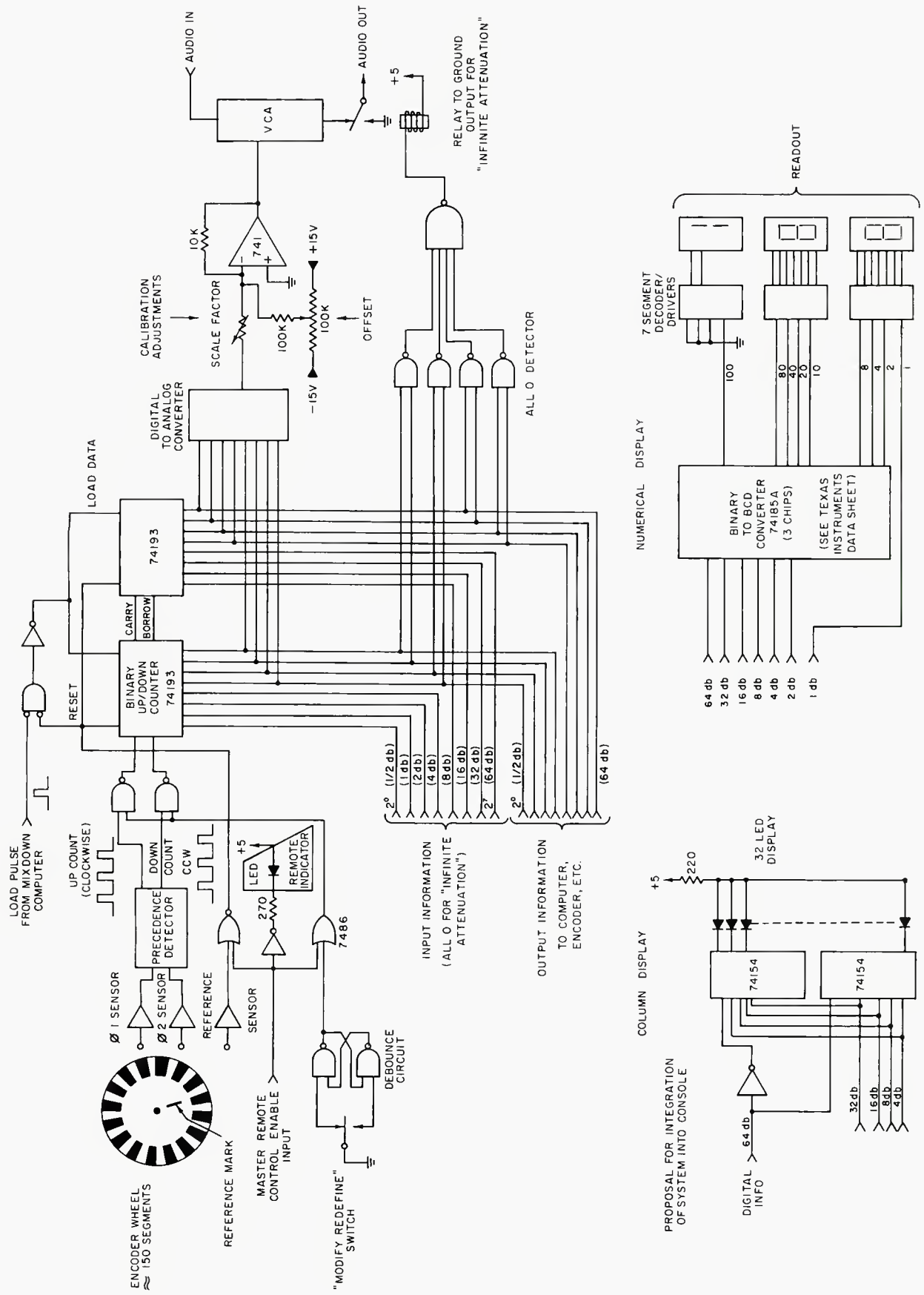
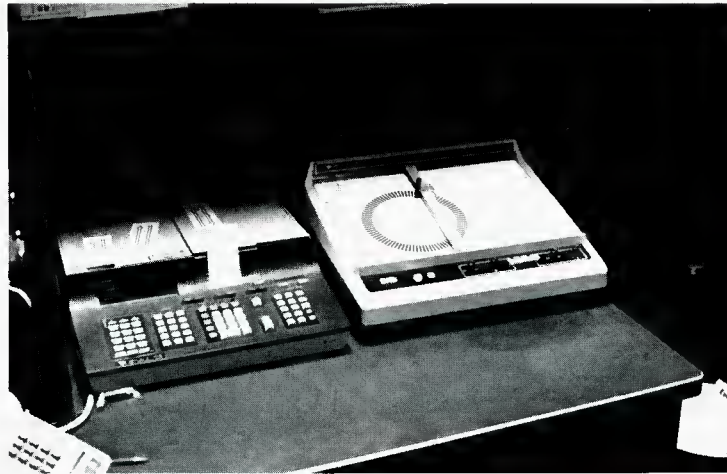

Figure 3. Proposals for the integration of optical encoder systems into a console.



The computer drawn encoder artwork.

URE 2), we see that the system starts, as might be expected, with a rotary (or linear) encoder. Direction of rotation is determined as described earlier, and the pulses from the precedence detector are applied through gates (whose function will be described below) to an eight-bit binary up/down counter. This counter stores the position of the encoder. The output of the counter is applied simultaneously to three circuits: the optional digital readout giving attenuation or gain in dB; the data bus to the automated mixdown computer, and to the digital-to-analog converter. The analog output from the converter goes to a calibration circuit and then to the vca, which performs the gain control function.

So far, ignoring the digital signals available, we have what was described in the introduction—a noiseless variable attenuator. Let's now consider the function of the digital signals. First, the eight bit gain data can be applied to a digital readout circuit. These eight bits are in binary form and can be left that way if a column display (see diagram) is desired, or can be converted to decimal if a dB reading in digits is desired. The circuit shown gives an arbitrary reading of 0 through 127 on the numerical indicators. Relatively simple digital circuitry can be used to offset the reading so that zero indicates 0 dB gain instead of infinite attenuation. (Methods of doing this are beyond the scope of this article.) Next, the eight bits can be applied to an automated mixdown computer. In actuality, these lines would go to multiplexers, which would also encode the gain data from this and many other channels into a serial bit stream suitable for storing on analog tape. Thus, attenuator subsystem (1) controls the gain of the audio channel and (2) gives the gain information to the mixdown controller.

In addition to the eight output lines, there are also eight input lines. Data on these lines can be used to program the gain of the channel independently of the position of the encoder. In the remote control enable mode, when the mixdown computer is controlling the gain, the encoder is disabled and data is decoded from the tape and fed to the gain determining element. This data is parallel loaded into the up/down counter, which is now acting as a storage latch.

The two above modes of operation are sufficient for the subsystem to operate in either the manual or computer operated mode. There are other features that make the unit considerably more versatile and convenient. One is the *reference mark* on the encoder. Since the counter can assume any state when turned on, the reference mark

zeroes the counter at a fixed mechanical position of the encoder. Thus, zeroing all the controls before turn on will assure a synchronized startup. Each control will also be re-synchronized between electrical and mechanical rotation every time it is turned to the infinite attenuation position. If freely rotating (non-mechanical stop) encoders are used, and the optional digital readout is employed, this feature is unnecessary. It might profitably be replaced by a single pushbutton which can zero the entire board.

An even more valuable feature is the capability to redefine the control position with respect to the gain of the vca. This can operate in both the manual and the automated mode. In the manual mode, depressing the *modify/redefine* switch inhibits the pulses from the precedence detector, so that the control position can be changed without disturbing the gain of the system. This might be convenient when a control is considerably higher or lower than its neighbors during a mix. You will probably wish to start out with all controls at some nominal centered position, and this will allow you to do it. In the automated mode, the remote control enable signal reverses the operation of the modify switch so that the encoder does not function *unless* the switch is depressed. (An led is provided to indicate when the control is in this mode.) When the switch is depressed, the encoder is activated and each pulse is either added or subtracted from the data which was stored in the counter/latch. This, of course, changes the gain during the mixdown. To prevent this information from being lost on the next computer update of the gain, the output lines must be sampled and any change since the last update noted. This change is stored in eight bits of computer memory and added algebraically to all succeeding data in the same channel.

FEASIBILITY

As stated earlier, this is not a completely engineered system. The above computer control functions may seem complicated, but the actual speed of currently available minicomputers is such that they can perform this type of operation on all channels thousands of times per second and still have time for lunch with the lathe. Other potential problems which exist include the possibility of under and overflow, *i.e.*, going from maximum to minimum gain (or *vice versa*) in only a small fractional turn. This can be obviated with a gate or so.

Other problems pertain to the imperfections of the vca. If the amplifier does not have a wide enough control range, a relay may be used to increase the attenuation in

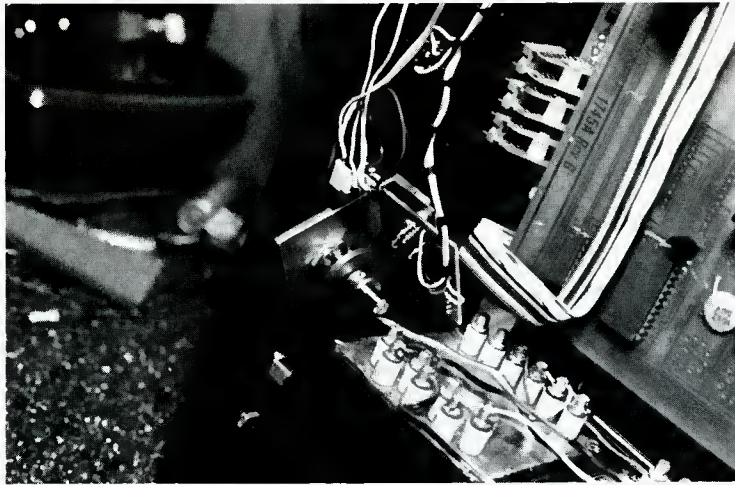

The complete encoder assembly plus electronics

the zero position (see FIGURE 3). Undoubtedly, there is some control range preferable to the 8 bits/128 decibels selected for convenience, and experimentation will establish this range. The cost of the system described herein is obviously much greater than that of a pot, or even a pot/vca combination. It is not clear how this system compares in cost with currently manufactured automation systems, and this will determine whether a system such as I've described will be manufactured or ignored. One factor which can mitigate the cost of the encoder/attenuator subsystem is the possibility of mass production. Each 16-track console produced could conceivably use up to 40 of these units, smaller consoles proportionately fewer. All the logic, including possibly the d to a converter, could be integrated onto a single LSI chip, whose price could be quite low if purchased in sufficient volume.

OTHER APPLICATIONS

The controls can be ganged without any physical connection. Simple connection of the pulse output of one encoder with the inputs of several counters can generate a stereo or quad fader. Connecting the pulses in reverse can cause one fader to increase while the other decreases, creating the prototypical pan pot. (Of course, the amplitude ratio curve would be improper, but this could be solved with some ingenuity.) A pan pot could also be implemented with the so called *absolute encoder*, which has many bands on the disc so that the entire binary code can be determined by the shaft position. A code could no doubt be devised to give the precise attenuation for a pan-pot curve.

As stated earlier, the encoder can be used to switch components in equalizers and other switch controlled functions. If the advantages of the encoder are promulgated and understood, no doubt other applications will be discovered.

To the author's knowledge, the incremental optical encoder has thus far found only two applications in professional audio thus far, the delay line and the tape search unit.¹ Whether the other applications described in this article become practical or remain experimental will no doubt depend upon economic considerations. Possible new applications suggested and developed by readers of this article may bring more optical technology to the audio field. ■

¹Factor and Katz, *Automatic Tape Transport Control*, db August-September, 1972, p. 42.

REFERENCE

If you are interested in experimenting with the optical encoder the most important step is to obtain accurate artwork. The dark area must be absolutely opaque. The clear area must be clean. The boundary between the edges must be sharp. The segments must be evenly spaced. Unless you are an experienced draftsman, you probably will not be able to do the job by hand. There is nothing more frustrating than drawing 99 perfect segments and then discovering that the last one is a little too close to the first. We have a computer program that will generate artwork suitable for photographing and reduction. The segmented circle is about eight inches in diameter and the segments are about one inch long, drawn black and white. Any local custom photographic house should be able to produce a reduced negative which can then be mounted on a shaft. A small cross-hatch denotes the center.

If you would like to obtain artwork for an encoder, send the following: Number of segments, your name and address, and a check or money order in the amount of \$7.40 to cover computer time, supplies and postage. (Please don't ask to be billed; the paperwork would cost more than the computer time). Make check payable to Eventide Clock Works, Inc.

Send the above to Eventide Clock Works, Inc., 265 W. 54th Street, New York, N. Y. 10019.

We can do decent art-work up to about 250 segments. However, do not request over 100 unless you have special optics or want to fidget with the G.E. interrupter modules very carefully. Do not ask for a duplication of some artwork already on hand; each must be an original, since a reproduction is not sufficiently opaque and will give pinholes when photographed. As the number of lines increases, the device becomes more sensitive to centering and play in the shaft. Above 100 segments, pay special attention to these aspects.

The New Standard for Weighted Peak Flutter Measurements

There are now international standards that all agree on the correct methods of measuring and reporting flutter characteristics.

THE NEW *American National Standard Method for Measurement of Weighted Peak Flutter of Sound Recording and Reproducing Equipment*, ANSI S4.3-1972 [1] has several advantages over the old obsolete standard [2]:

1. The ranking of the degradation of sound quality due to flutter, when measured objectively with the weighted peak flutter measurement, will predict fairly well that which would be given by a listening panel judging subjective flutter. (The measurement of flutter content. [2] bore little relationship to how a recorder would sound.)

2. The requirements for the measuring equipment, the flutter meter, that are given in the new standard are sufficiently complete so that different equipment built to this standard will not only give the same readings on a calibrating sine wave, but will also give the same readings on a dynamic flutter waveform. (The previous standard [2] gave only general ranges for requirements, and no specific requirements for the dynamic response.)

3. Measurements according to the new standard are identical to those used internationally in IEC Recommendation 386, and CCIR Recommendation 409-2, and to the

German standard DIN 45 507 which has been widely used in Europe. This greatly enhances the exchange of information on recorder performance and facilitates sales and purchases of equipment in overseas areas.

The technical background of the new standard has been published elsewhere [3][4], and this paper is a summary of the contents of the standard itself.

SCOPE

"This standard specifies the weighted peak method of measurement for predicting subjective flutter of sound recorders and reproducers for normal audio usage." [1, sec. 1].

DEFINITIONS

"Flutter, wow, drift, and frequency-modulation noise are all forms of distortion caused by undesired frequency modulation introduced into the signal by an irregular motion of the recording medium during the recording. Although flutter, wow, drift, and frequency-modulation (friction) noise (scrape flutter) are defined, the standard covers only the measurement of weighted peak flutter.

Weighting is defined as "the use of a psychoacoustically

John G. (Jay) McKnight is (or should be) well known to audio professionals. He is presently engineering vice president of Magnetic Reference Laboratories of Palo Alto, California.

This article is reprinted in revised form with permission from the Journal of Audio Engineering Society, Volume 19, pages 859-861 (November 1971).

determined time response in an objective measuring equipment. This is done in order to obtain indications which better predict the subjective values than would wideband measurement with a meter having either an instantaneous time response or a long-time average or rms response."

Weighted peak flutter is defined as "flutter and wow indicated by the weighted peak flutter measuring equipment specified in IEEE standard 193-1971" [1, sec. 2].

THE FLUTTER METER SPECIFICATION

"The measuring equipment shall consist of a frequency demodulator which produces an output voltage proportional to the relative frequency change ($\Delta f/f$), followed by a weighting filter, a peak rectifier, and an indicator." [1, sec. 5].

The test frequency now specified is the "preferred frequency" of 3150 Hz. The response curve of the combination of the demodulator, the weighting filter, and the indicator is to be as shown in FIGURE 1. A peak-to-peak rectifier is used, but the meter is calibrated in the peak value (one half of the peak-to-peak value).

The dynamic characteristics of the flutter meter are specified in terms of the indication for a pulse train of frequency modulation, as shown in FIGURE 2. The pulses have constant amplitude, constant 1-s repetition rate, and adjustable length of 10 to 100 rms. They have the same peak-to-peak amplitude as the 4-Hz sine wave. The flutter meter reading with the sine wave of frequency modulation is taken as reference (100 per cent). Then the relative meter readings are measured for the pulse train of frequency modulation. The flutter meter readings must be as shown below (tolerances are also given in the standard).

Pulse Length	A/[ms]	10	30	60	100
Relative Indication	B/[%]	21	62	90	100

The other dynamic requirement is for the decay time. When the 100-ms pulse is used with a 1-s repetition rate, the decay time of the flutter meter must be such that between the pulses the indicator falls to a reading of from 36 to 44 per cent of the maximum.

A number of good engineering practice items are given: the instrument should work with test frequencies between 3000 and 3300 Hz in order to allow use with off-speed recorders or reproducers, and also with both old test records at 3000 Hz and new test records at 3150 Hz. A basic accuracy of at least plus or minus 10 per cent of full scale is suggested. A required input voltage of not more than 100 mV is suggested, and an input impedance of not less than 300 kilohms at 3150 Hz. Finally, provision for connecting external equipment (for example, an oscillograph) with or without the weighting filter is suggested.

AVAILABILITY OF FLUTTER METERS AND TEST RECORDS

Flutter meters which measure weighted peak flutter according to the standard are now available from several manufacturers: BKH; EMT and Woelke (Gotham Audio); Ferrograph; and Mincom Division of 3M (the Mincom instruments were developed by Bahrs Industries, and originally manufactured by Micom, later called DMC). Check with the manufacturers which models measure weighted peak flutter according to ANSI S4.3-1972. Note also that some of these meters have switched positions which allow non-standard measurements such as unweighted peak, or long averaging time—slow—etc. Be sure you know how to set the controls to get the standard weighted peak flutter.

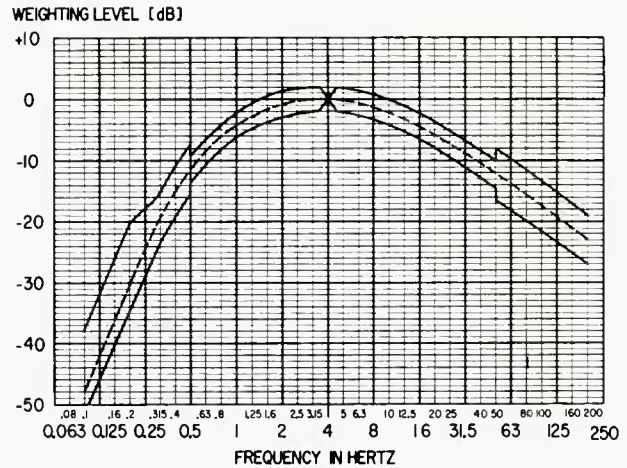
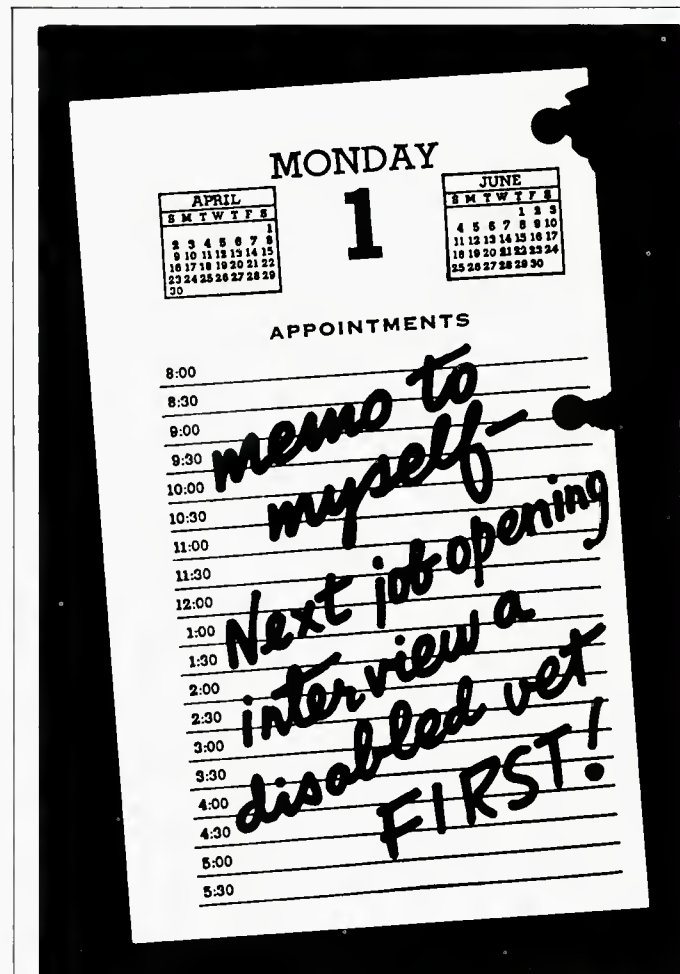

Figure 1. The standard weighting curve.

The term *DIN flutter* has been used for weighted peak flutter. While DIN flutter is not incorrect, it is preferable in the USA to reference the American National Standard [1] and the IEC Recommendation 386, rather than the German Industrial Standard (DIN).

Test records with a 3150 Hz signal which may be used for flutter measurements according to the new standard may be obtained, for instance, from the following companies:



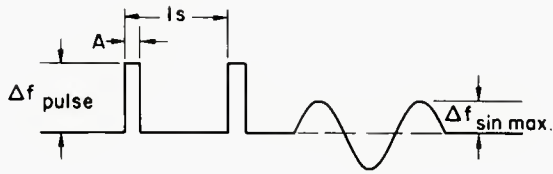

Figure 2. The pulse form for measuring dynamic characteristics.

Tape records: Ampex Corporation, Redwood City, California; Standard Tape Laboratory, Oakland, California.

16-mm and 35-mm motion picture film records: Standard Tape Laboratory, Oakland, California

Disc records: Gotham Audio Corporation, New York, N.Y.

MEASUREMENT PROCEDURE

"The measurements of normal recording and reproducing systems shall be made on one element only of the system (either the recorder or the reproducer, but not on both) under such conditions that the weighted peak flutter in the remaining parts of the measuring system is negligible.

"When this condition cannot be fulfilled, a recorder/reproducer may be measured by recording a 3150 Hz test frequency and subsequently reproducing this record several times, measuring in each case the total weighted peak flutter and calculating the arithmetic average value of these measurements. Weighted peak flutter shall not be measured while simultaneously recording and reproducing." [1, sec. 3.3].

If, because of random flutter or very low-frequency flutter, the reading varies with time, the maximum value shall be read and reported. Since in most systems conditions vary in such a manner as to give different flutter readings, a choice of reporting forms is given: either report the reading for each condition, or else give the reading the worst combination of factors.

REPORTING RESULTS

Weighted peak flutter should be reported in the following manner:

"Weighted peak flutter of the recorder (reproducer) (recording and reproducing system) \pm %" [1, sec. 4].

The sign \pm is used to indicate that the peak rather than peak-to-peak value has been given.

A statement of conditions may also be required; for example, for a tape recorder, the speed and the reel size (minimum hub diameter, maximum outside diameter, etc.). ■

REFERENCES

1. *American National Standard Method of Measurement for Weighted Peak Flutter of Sound Recording and Reproducing Equipment*. ANSI S4.3-1972, ANSI, 1430 Broadway, New York, N.Y. 10018; price: \$3.00. Also *IEEE Std. 193-1971*, published in *IEEE Trans. Audio & Electroacoust.*, Vol. AU-20, pp. 81-88 (March 1972).
2. *Methods for Determining Flutter Content in Sound Recorders*, IEEE Standard 193-1953 and ANSI Z57.1-1954 (obsolete).
3. *Development of a Standard Measurement to Predict Subjective Flutter*, J. G. McKnight, *IEEE Trans. Audio and Electroacoust.*, vol. AU-20, no. 1 pp. 75-78 (March, 1972).
4. *On Measuring Frequency Variations*, E. Belger, *IEEE Trans. Audio and Electroacoust.*, vol. AU-20, no. 1, pp. 79-80 (March, 1972).

Think of what just one company can do to stop pollution. We have.

Twenty years ago some farsighted businessmen had an idea. To establish an organization to combat littering. They called it Keep America Beautiful, Inc.

Since then, KAB Inc. has led a national movement to stop not just littering. But pollution as well. A movement that involves almost 70 million Americans.

To show you what companies like yours are doing to fight pollution, we've put together this folder, "What industry is doing to stop pollution."

It's a special way to celebrate our first twenty years.

WHAT INDUSTRY IS DOING TO STOP POLLUTION

**People start pollution.
People can stop it.**

Please send me a free copy of your guide.

Name _____

Street _____

City _____

State _____ Zip _____

A Public Service of
This Magazine &
The Advertising Council

Keep America Beautiful

99 Park Avenue, New York, New York 10016

JOSEPH SALDANA

Low Cost Four Channel Remote Box

This article describes a multi-channel control box that can be built at very low cost—under \$70 for four channels—using parts that may be in your existing collection that may further lower the cost.

THE REMOTE AMPLIFIER described on these pages has served perfectly for a year now and cost less than half the price of the least expensive commercially built unit.

It is built around the AA-300 circuit board of RHA Audio of West New York, New Jersey. The four channel microphone mixer in front of it uses carbon pots (Ohmite or Centralab AB types) and introduces a loss of about 8 dB. The carbon pots, besides costing only a fraction of the price of regular step-type attenuators take up less room, in a unit which was planned to fit into an attache case.

Originally I built the amplifier with 50-ohm inputs but later a change to 250 ohm pots showed better leading for the microphones (AKG, Shure, E.V.) and tests with a one kHz tone, before and after, revealed a 5 dB increase in the output level of the microphones.

This is important since the circuit board itself has a gain of 80 dB, minus the loss in the mixer. It was for this

reason that I removed an output pad that I had originally installed and simply put a 1000-ohm resistor across the line terminals to stabilize the amplifier. This arrangement, with the proper resistor in series with the vu, supplies plus 10 dBm to the phone line when the vu reads zero.

For those events where one might expect to encounter very low sound levels, I have used the new Electro-Voice condenser mikes for an extra safety margin, since their output is up to 15 dB higher than the dynamics.

The amplifier is flat within 2 dB from 20 to 20 kHz, with distortion figures under one percent for an output of 100 mW.

The 9 volts d.c. for powering can be obtained from six alkaline C cells. With a steady tone, zero level output (plus 10 dBm) the amplifier drain is 50 mA. I was told by engineers at Union Carbide that with this drain I might expect a useful life of 150 hours, (400, using D cells) which incidently I have found to be true during the past year.

The mixer, despite its simplicity and low cost, functions quite acceptably. The output of the mixer measures 60 ohms with all the pots closed and 120 ohms with all open. Despite this, while feeding a one kHz test tone into channel one and varying pots 2, 3 and 4 from mini-

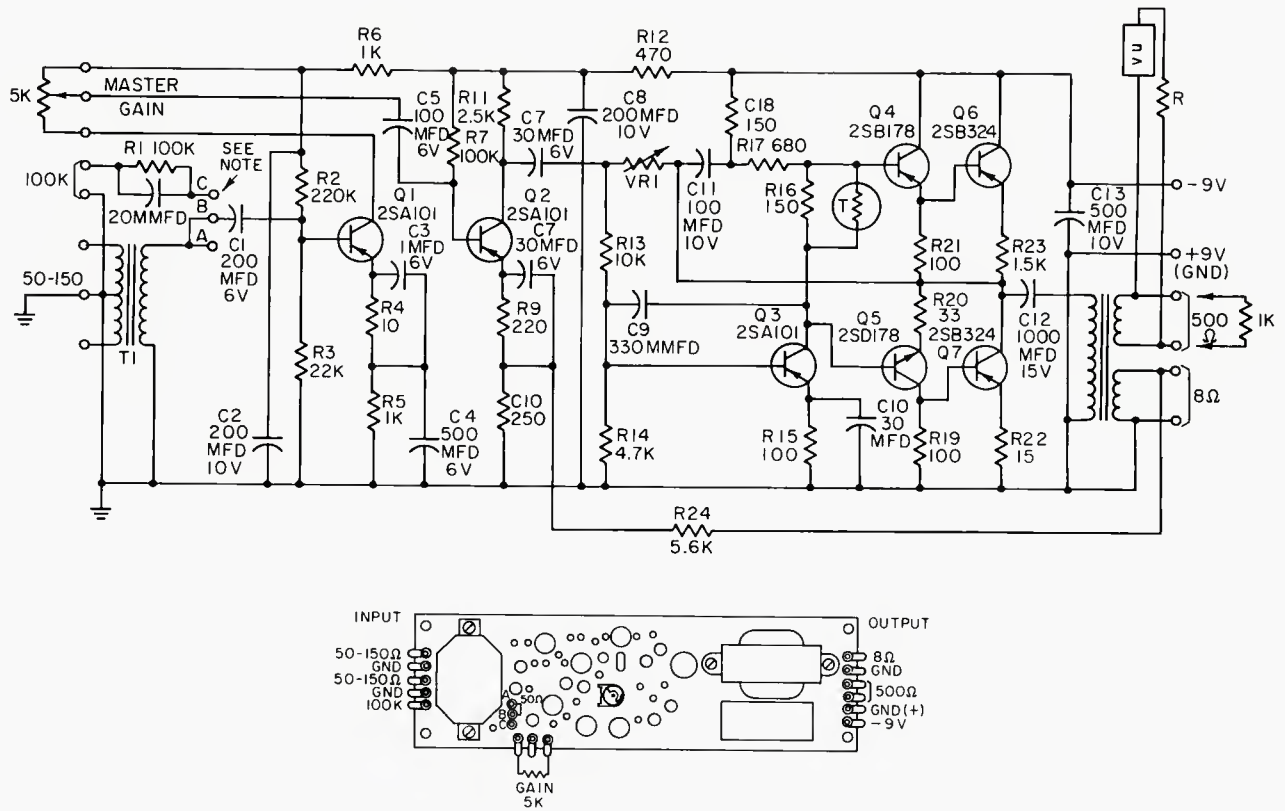

NOTES

1. The AA-300 Amplifier requires a 5,000 Ohm volume control which can be mounted externally providing the leads to such a control do not exceed approximately 6 inches. We suggest that this control be of a locking type and be set at a fixed gain level. Due to the time constants in the Amplifier, the response of this control is in the order of fractions of a second and consequently it should not be used to ride gain.
2. The removable link on the Amplifier Board is used to change input impedance. For a 50 to 150 Ohm impedance, the link is placed between A and B. For 100,000 Ohm input impedance, the link is placed between B and C. The 100,000 Ohm impedance is achieved by means of a dropping resistor and when the Amplifier is used in this manner, the overall gain will drop about 50 db. For 2,000 Ohm input impedance, the link is removed entirely and the signal is fed directly to point B.

Figure 1. The AA-300 amplifier.

Parts Prices

- \$18.00—amplifier circuit board (Harvey Radio, NYC)
- 9.00—four XL females
- 3.20—alkaline batteries
- 9.00—four AB carbon pots
- 1.25—5k pot (master gain)
- 3.50—cabinet
- .80—four 240 ohm resistors
- 5.60—vu meter (Lafayette Radio)
- 1.50—line output terminals
- .75—phone jack
- .75—SPST toggle switch
- 3.00—battery holders
- 1.50—knobs

\$57.85

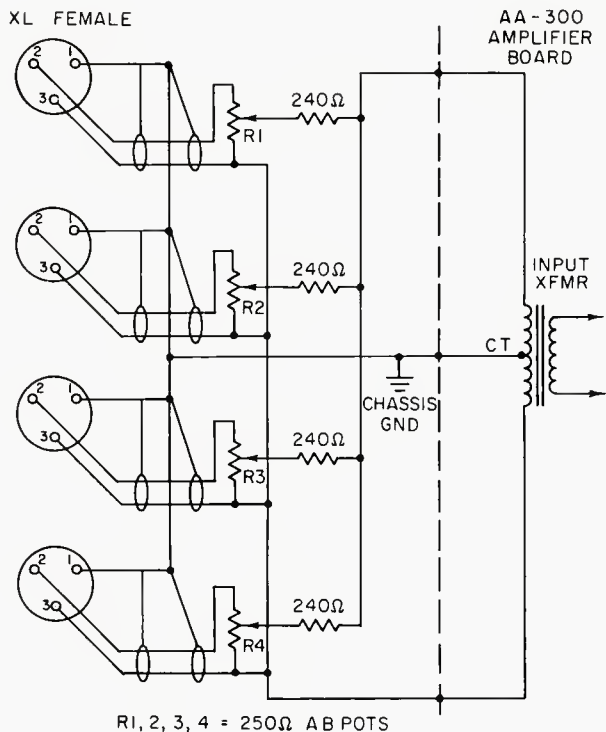

Figure 2. The input mixer section. The transformer feeds the amplifier board input.

imum to maximum, the vu output meter showed no more than plus or minus 1/2 dB variation. The mixer works into an input transformer with a center-tapped primary rated at 50 to 150 ohms.

The remote amplifier was built into an aluminum box but a steel cabinet or box is preferable for suppression of a.c. hum fields.

For those technicians who have parts—switches, female XL's, vu meters, phone jacks, etc., the building costs will be lowered.

Incidentally, the circuit board has a high-level input that could be wired for amplified cue, plus an eight-ohm winding that could operate a small cue speaker. ■

Figure 3. This simple circuit will match the output of the AA-300 to the phone line feed.

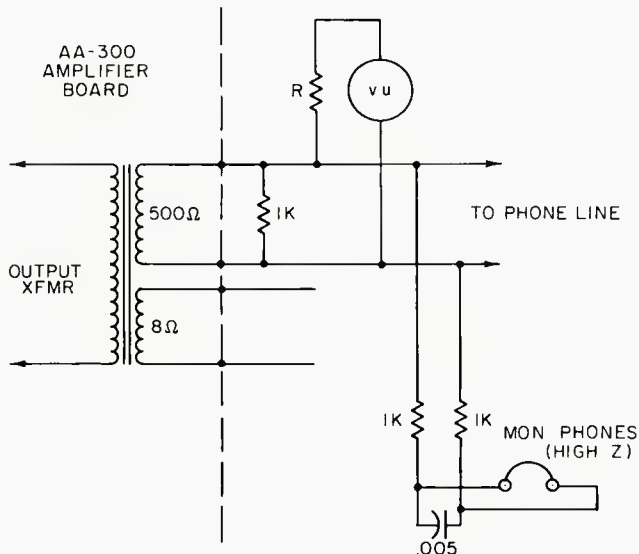

Work for free. The pay is great.

No matter what you do full-time, there's something you can do part-time. Helping people help themselves.

The pay is nothing but the rewards are fantastic.

Right in your own home town, there's a desperate need for your skills. Whether you're a doctor. A lawyer. A typist. Or a tutor.

If you can spare some of your spare time, even if it's only for a few hours a week, call your local Voluntary Action Center. Or write: "Volunteer," Washington, D.C. 20013.

We'll put you in touch with the people who need what money can't buy. They need you.

Volunteer.



The National Center for Voluntary Action



A Public Service of This Magazine & The Advertising Council

CLASSIFIED

Closing date is the fifteenth of the second month preceding the date of issue. Send copy to: Classified Ad Dept.
db THE SOUND ENGINEERING MAGAZINE
980 Old Country Road, Plainview, New York 11803

Rates are 50¢ a word for commercial advertisements. Non-commercial and employment offered or wanted placements are accepted at 25¢ per word.

FOR SALE

REEL SPECIALISTS; 10.5 inch reels, NAB \$2.00 each; Precision, \$5.00 each; other sizes available; NAB flanges, \$.75 each. Add 5 per cent postage. P.O. Box 338, Dunwoody, Ga. 30338.

NORTHWEST AREA, professional audio equipment and systems design. R. E. Munger Co., Seattle, Washington, (206) 365-1999. An Altec Acousa-Voice contractor.

ALLEN AND HEATH MIXERS; H/H amplifiers; Community Light and Sound horns and drivers; AKG, Keith Monks microphone stands; all your sound reinforcement needs. Brandy Brook Sound. (401) 821-9580.

HAECO announces complete repair service and overhaul for all Westrex cutterheads. Conversions of 3D-II and older models to higher performance standards and reliability. Helium cooling systems and hi-temp coils can protect your investment. Repair insurance program available. Rapid service. Lower cost. HAECO, 14110 Aetna, Van Nuys, California 91401.

**ONE STOP
FOR ALL YOUR PROFESSIONAL
AUDIO REQUIREMENTS
BOTTOM LINE ORIENTED
F. T. C. BREWER CO.
P.O. Box 8057, Pensacola, Fla. 32505**

TUNED ROCK P.A.'S—customized touring sound systems, including feedback suppression, narrow band (5 HZ!), acoustic voicing/equalization (\pm dB at your ears); room design/measurement/treatment; hundreds of professional products, all shipped prepaid/insured from Music & Sound, Ltd., 11½ Old York Rd., Willow Grove, Pa. 19090. (215) 659-9251.

WHATEVER YOUR EQUIPMENT NEEDS—new or used—check us first. Trade your used equipment for new. Write for our complete listings. Broadcast Equipment & Supply Co., Box 3141, Bristol, Tenn. 37620.

LOWEST PRICES, fastest delivery on Scotch recording tapes, all widths. We will not be undersold. Amboy Audio Associates, 236 Walnut Street, South Amboy, N.J. 08879. (201) 721-5121.

TWO-CHANNEL MONITOR EQUALIZERS for your Altec's and J.B.L.'s are a steal at \$150. Music & Sound, Ltd., 11½ Old York Rd., Willow Grove, Pa. 19090. (215) 659-9251.

BROADCAST AND RECORDING EQUIPMENT: Scully; Mototech; Langevine; Electrodyne; Q.R.K.; Micro-Trak; M.R.L.; Nortronic; McMartin; U.R.E.I.; used Neumann; E.V.; A.K.G.; Sennheiser; Atlas; Ferrograph; HAECO; Stevenson; Gately; D.B.X.; Advent; Altec; Fairchild; Audio Designs; 3 M; Magnacord; Telex; inovonics; disc recording systems; package deals; installations; service. Wiegand Audio, Middleburg, Pennsylvania 17842. (717) 837-1444.

HP AUDIO OSCILLATORS: 200C, \$75.00; 201, \$85; 205, \$95; SKL Two channel audio filter, \$100.00. I. Kaufman, (212) 757-6440.

FOR SALE: 32 Penny & Giles faders @ \$50.00; 4 Automated Process E.Q.s @ \$30.00; 1 mixing console, as is, \$4,000.00; 10 Automated Process faders, @ \$35.00; 10 Langevin faders, @ \$20.00. Studio Six, Montreal, Canada. (514) 861-9776.

ONE GR941A, TWO WE/111C TRANSFORMERS; \$20 each. C. Benson, 7554 Trask, Playa del Rey, Ca. 90291.

FOR SALE: Audio Designs console; 16 in/16 out; three years old. \$15,000. Call (312) 644-1666 for further information.

SAVE 500! Revox professional model, Sony C500 and ECM22 condenser microphones; brand new, factory boxed. Cone. (213) 798-0511.

ONE STOP STUDIO SHOPPING. Come in and let our experts set up your studio or duplicating plant. Lang Electronics, 14 E. 39th St., New York, N.Y. 10016.

MULTI-TRACK

8 and 16

**TRACK RECORDING CONSOLES
THE SOUNDEST DOLLAR SPENT
IN PRO AUDIO TODAY**
1965 CHEREMOYA AVE.,
HOLLYWOOD, CALIF. 90028
P.O. Box 3187, Hollywood, CA. 90028
(213) 467-7890

FINANCE IT ALL. Ampex 440B: mono, \$51.73; stereo \$68.98; 4 track, \$103.48; 8 track, \$195.50; MM-1100: 16 track, \$379.50; Scully 280B: mono, \$55.09; stereo \$71.18; 4 track, \$107.99; Tascam: console, \$43.47; stereo 2 track recorder, \$34.96; 4 track, \$44.85; JBL: 4310, \$5.93; 4320, \$13.25; Phase Linear: 400, \$11.47; 700, \$18.38; Gately: 16 track console, \$499; Dolby: 361, \$14.95; M-16, \$184. Above prices per month on 60 month purchase plan. Also available on purchase plan — Electro-Voice, Atlas, Schöeps, Prokit, Pentagon duplicators, Metrotech recorders and loggers. In the south, call Bill Brock at (615) 794-7537. Other areas call Bill Hamilton or Ed Gately at (215) 449-6400. **Gately Electronics, Inc., 57 W. Hillcrest Avenue, Havertown, Pa. 19083.**

CUSTOM-BUILT SPECTRA-SONICS 16-in/8-out console; fine board, fine price. Write for information. **Cookhouse Recording, 2541 Nicollet Avenue, Minneapolis, Minn. 55404. (612) 827-5441.**

AMPEX, SCULLY, TASCAM; all major professional audio lines. Service, experience, integrity. 15 minutes George Washington Bridge. **Professional Audio Video Corporation, 342 Main St., Paterson, N.J. 07505. (201) 523-3333.**

SOLID-STATE AUDIO MODULES. Console kits, power amplifier kits, power supplies. Octal plug-ins—mic, eq, line, disc, tape play, tape record, amplifiers. Audio and tape bias oscillators. Over 50 audio products, send for free catalog and applications. **Opamp Labs, Inc., 172 So. Alta Vista Blvd., Los Angeles, Ca. 90036. (213) 934-3566.**

BUILD YOUR OWN highest quality microphone mixers, consoles, phono preamps, crossovers, equalizers, or voltage controlled devices, using modules. Free catalog. **Burwen Laboratories, 209 Middlesex Turnpike, Burlington, Mass. 01803. (617) 273-1488.**

NEW YORK'S LEADING supplier of professional audio/video equipment and hi-fi stereo components. All major brands in stock. Call for quote—sales—service—leasing—trade-ins. **Martin Audio, 320 West 46th Street, New York, N.Y. 10036. Telephone: (212) 265-6470.**

SPlice FASTER, BETTER BY SHEARING . . . replaces razor; specify .250-inch or cassette: \$16.95. With attached splicing tape mechanism, \$24.95. Details—**NRP Box 289, McLean, Va. 22101.**

TASCAM MIXING CONSOLES—\$1,890. Tascam 1/2-inch recorders—\$1,950. Tascam 8-track recorders—\$3,970. All shipped prepaid/insured, including free alignment and calibration. **Music & Sound Ltd., 11 1/2 Old York Rd., Willow Grove, Pa. 19090. (215) 659-9251.**

SYSTEMS DESIGN ENGINEERING

Broadcast Recording Film Studios Fifty lines of professional audio and film equipment, including Scully, Electrodyne, JBL, Vega, UREI, Tascam, and Sennheiser. Call or write for a system proposal for your installation.

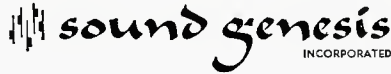
 **sound genesis**
INCORPORATED

445 Bryant St.,
San Francisco, Ca. 94107
Professional Services for
Professionals

AUDIO EQUIPMENT, new and used; custom consoles built to your specifications using the components of your choice. Whether you're building a new studio or remodeling your present one, check us first for a package price. **Amboy Audio Associates, 236 Walnut St., South Amboy, N.J. 08879. (201) 721-5121.**

AMPEX 300, 352, 400, 450 USERS—for greater S/N ratio, replace first playback stage 12SJ7 with our plug-in transistor preamp. For specifications write **VIF International, Box 1555, Mountain View, Ca., 94042. (408) 739-9740.**

PRE-EQUALIZED J.B.L. & ALTEC MONITORS. dbx companders; Little Dipper hum/buzz notch filters; Cooper Time Cube echo delay; B.B.C. & I.M.F. reference monitors; Lamb B Dolby processors; Ortofon and B. & O. ultra-track cartridges; Schöeps & A.K.G. condensers; Beyer ribbons; U.R.E.I. comp/limiters; Gately Pro-Kits; Infinity electrostatics; Crown amplifiers/recorders; Tascam, Community Light & Sound fiberglass horns; Q.R.K.; dozens more, plus class "A" warranty service station. Shipped prepaid/insured from **Music & Sound, Ltd., 11 1/2 Old York Rd., Willow Grove, Pa. 19090. (215) 659-9251.**



CATV—MATV PRODUCTS

- CONNECTORS
- WALLPLATES
- SPLITTERS
- AMPLIFIERS



AVA ELECTRONICS CORP.
242 Pembroke Avenue, Lansdowne, Pa. 19050
(215) 284-2500

FOR SALE: Tascam 1/2 inch deck, 4-track, only 10 hours' use; \$1,500. **John Crow, 2000 Beck Bldg., Shreveport, Louisiana 71101. (318) 424-2678.**

NEW YORK'S ORIGINAL ELECTRONIC WORKSHOP now has New York City's finest audio showroom, featuring Infinity, ESS, Phase Linear, Bose, Crown, Bang & Olufsen, etc.; knowledgeable and helpful sales assistance that is hard to find. We invite you to pay us an early visit. **Electronic Workshop, 10 E 8th St., New York, N.Y. 10003. (212) GR 3-0140.**

FOR SALE: Two Shure M67 accs., \$100 each; two B&W 70 loudspeakers, \$700 pair; much else; list available. **Michael T. Kobal, 3003 Van Ness St., N.W., Washington, D.C. 20008. (202) 244-3118.**

DIRECT BOX, \$30.00. Four output headphone cue box with mute, channel select, mono/stereo, and pad switches, \$60.00. **Gately Electronics, Inc., 57 West Hillcrest Avenue, Havertown, Pa. 19083. (215) 449-6400.**

WANTED

WANTED: SALES REPRESENTATIVE for 8 track studio—high commission basis. Call (212) 224-7813.

WANTED: Transcription collectors to write. **Ed Breland, 833 12th Street, Laurel, Miss. 39440.**

WANTED: TYPE APPROVED MICRO-WAVE SYSTEM to pass color. Respond to **Box 4371, Inglewood, Ca. 90309.**

EMPLOYMENT

PROFESSIONAL RECORDING PERSONNEL SPECIALISTS. A service for employers and job seekers. Call today! **Smith's Personnel Service, 1457 Broadway, N.Y.C. 10036. Alayne Spertell 212 Wi 7-3806.**

PEOPLE, PLACES, HAPPENINGS

● **Jerold Bush** has been appointed to the position of teletechnical product specialist for the **London Company**, of Cleveland, Ohio. The London Company distributes electronic test equipment manufactured by **Radiometer A/S**, of Denmark. Mr. Bush comes to the London Company from **Pioneer Standard Electronics**.

● **Rohde & Schwarz Sales Co. (USA) Inc.** of Passaic, N. J., has taken over the exclusive distributorship of the **Schwarzbeck** line of EMI/EMC measuring instruments in the U.S.A. These testing devices, produced in Germany, are used to measure radio interference from electrical machinery and appliances, according to set internationally accepted standards.

● What promises to be an exciting and informative meeting will be held by the **Boston Section** of the **Audio Engineering Society**. Their February meeting to be held on February 27th will have **Richard Burwen** of **Burwen Laboratories** as a guest. His topic will be noise reduction to be sure, but with a concentration on noise reduction in the disc reproduction system. Details available at press time did not name a time or place so call **Paul Moverman** at (401) 463-7272 for details.

● **McMartin Industries** of Omaha, has moved into new headquarters at 4500 S. 76th St., Omaha, Nebraska, 68127. This move consolidates all of the departments of the company, which had been scattered in various buildings. They hope to use this opportunity to expand their research and engineering services, as well as to increase the volume of manufacturing output.

● Assuming responsibility for the design, development, and engineering of all Bogen products and administration of the division's engineering department, **Ronald Kashkin** has been appointed vice president, engineering, of the **Bogen Division of Lear Siegler, Inc.**, Paramus, N. J. Prior to joining Bogen, Mr. Kashkin was employed by the **American Instrument Laboratory**.

● **James A. Dhimos** has been appointed as director of marketing for **Acoustic Research, Inc.** of Norwood, Massachusetts, high fidelity speaker systems manufacturer. Mr. Dhimos has previously been associated with **GTE-Sylvania**, **Philco**, and **H. H. Scott**, where he was active in stereo components, communications, closed-circuit television systems, and aviation lighting.

● **Cleveland Recording Company** has informed **JVC America, Inc.** and its parent company, the **Victor Company of Japan, Ltd.**, through its patent attorneys that JVC's CD-4 discrete quadridisc system is in apparent infringement of a patent issued to **Kenneth Hamann**, president of Cleveland Recording. U.S. Patent #2,849,540, granted in 1958 to Mr. Hamann, specifically covers the use of a 30 kHz sub-channel signal to record multi-channel audio information on discs and other mediums, plus other electronic decoding equipment. JVC America has been invited to enter into a licensing agreement with Mr. Hamann for the use of the invention.

● **John Eargle** has formed his own consulting firm, **JME Associates**, at 6363 Sunset Blvd., Hollywood, California. The firm will specialize in the quadraphonic hardware and software areas. Mr. Eargle was formerly director of new products for **Altec Sound Products** and had also been associated with **RCA** as manager of quality manufacturing and recording.

● Filling a newly created position, **Cedric R. Bastiaans** has joined **Koss Corporation**, Milwaukee, as chief engineer. Mr. Bastiaans was formerly manager of special devices research at **Westinghouse Electric** with whom he was affiliated for the past ten years. Prior to that he was associated with **Philips Phonographic Industries**, **The Netherlands**. Mr. Bastiaans is the author of numerous papers on sound reproduction and related subjects.

● The **Institute of Audio Research** in New York City has a number of programs planned. First of all, IAR has developed a new twelve-week course in preliminary digital logic math, focused on the use of this technique in the recording industry. Two courses are planned, one commencing the end of February, the second the middle of March. **John Woram**, special projects director at the Institute and **db** columnist, will conduct a producers'/arrangers' workshop starting on February 28 and devoting four days and evenings to the study of recording technology, equipment, and its application. Under the leadership of **Kenneth R. Barr**, the Institute has recently established an alumni association for its graduates, which will issue a news letter not only giving the usual alumni personal information, but also news of studio techniques and developments. For all or any of the above, contact the Institute of Audio Research, 64 University Place, New York, N.Y. 10003, (212) 677-7580.

● **Columbia Records** has announced that **Fairchild Semiconductor**, a manufacturer of integrated circuits, will produce the full range of i.c.s for distribution to producers of the SQ quadraphonic matrix system. Fairchild Semiconductor, of Mountain View, California, joins **Motorola Semiconductor** and the **Sony Corporation**, who have also been producing SQ i.c.s.

● **William E. Amos** has been appointed a vice president of **Philips Broadcast Equipment Corp.** in charge of the audio-video systems division. Mr. Amos' appointment is part of a restructuring of Philips' marketing efforts, which have been distributed among three categories: audio-video systems, professional television equipment, and government systems for defense. Before joining Philips, Mr. Amos was assistant vice president of **Sony Corporation of America**, in charge of market development of video products.

noise reduction takes a giant step forward with the dbx 216

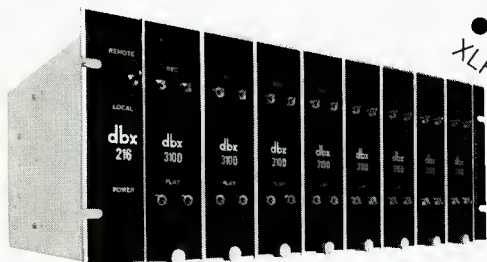

With the dbx 216 professional tape noise reduction system, you get every one of these advanced approaches:

- in excess of 30 dB of noise reduction which gives you an extra safety margin and lets you forget about noise build-up even in 24 channel applications
- 10 dB headroom improvement eliminates tape saturation or tape recorder overload worries
- 100 dB dynamic range makes level setting less critical
- no pilot tones or level matching required, just turn on and record
- true RMS level sensing guarantees perfect code/decode tracking and transient reproduction throughout the record and playback cycle
- simultaneous record and playback functions eliminate mode switching, remote control necessity, etc.
- spare two-channel module supplied with a 16-channel system reduces down-time to near zero
- complete cable assemblies with prewired mating connectors make installation a simple 30-minute plug-in operation
- expandable modular design allows purchase of as few as four channels, with easy subsequent expansion to 8, 16, 24, or any number of channels
- typical 16-channel simultaneous record/playback noise reduction system with spare module and cables, ready to install costs \$8,200
- available from professional audio dealers or the factory

dbx, Incorporated, 296 Newton Street, Waltham
Massachusetts 02154



dbx

One of the world's most popular microphones

The E-V 635 A

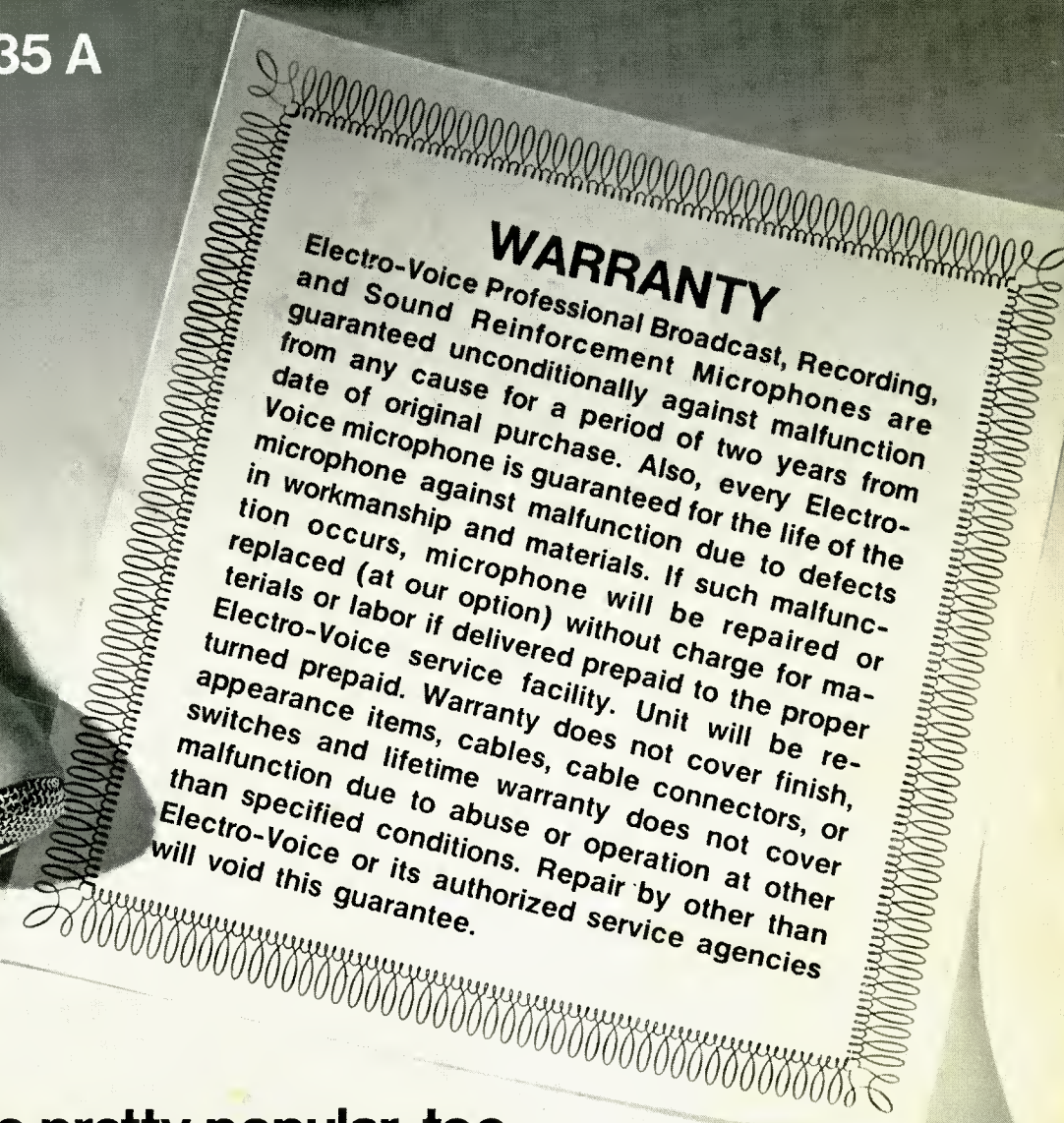

WARRANTY

Electro-Voice Professional Broadcast, Recording, and Sound Reinforcement Microphones are guaranteed unconditionally against malfunction from any cause for a period of two years from date of original purchase. Also, every Electro-Voice microphone is guaranteed for the life of the microphone against malfunction due to defects in workmanship and materials. If such malfunction occurs, microphone will be repaired or replaced (at our option) without charge for materials or labor if delivered prepaid to the proper Electro-Voice service facility. Unit will be returned prepaid. Warranty does not cover finish, appearance items, cables, cable connectors, or switches and lifetime warranty does not cover malfunction due to abuse or operation at other than specified conditions. Repair by other than Electro-Voice or its authorized service agencies will void this guarantee.

Our warranty is pretty popular, too.

It's a singular microphone, the E-V 635A. Used by engineers around the world. On TV, film, radio, in recording studios, and on stage. Chosen because it unfailingly delivers great sound with no fuss. If often seems that the tougher the problem, the better the 635A performs... and outperforms the competition. In fact, for many it is the standard by which all others are judged.

But even when things go wrong (as they sometimes do) E-V has the advantage. For instance, for the first 2 years we'll put your 635A (or any other E-V Professional microphone) back in operation fast, for only the cost of one-way postage. Even if you dropped it, or dunked it, or ran over the microphone with your remote truck!

It's a remarkable warranty because we build remarkable products. Designed to serve, and to solve your sound problems day after day. Your E-V sound headquarters is ready to help you select the E-V Professional microphones that exactly fit your needs. Or write us for the latest information on E-V professional sound products. Today.

Electro-Voice®

a **Gulton**
COMPANY