

THE PLESSEY COMPANY LIMITED

PLESSEY RADIO



SERVICE MANUAL

FOR

PR155B

MF/HF COMMUNICATIONS RECEIVER

Publication No. 061B

Issue 1

© 1973 The Plessey Company Ltd

The information contained herein is the property of The Plessey Company Limited and is not to be disclosed or used without the prior written permission of The Plessey Company Limited. This copyright extends to all the media in which this information may be preserved including magnetic storage, punched card, paper tape, computer print-out or visual display.

THE PLESSEY COMPANY LIMITED

PLESSEY RADIO

MARTIN ROAD · WEST LEIGH · HAVANT · HAMPSHIRE

TELEPHONE HAVANT (070 12) 6391 TELEEX 86227

CONTENTS

	Page
<u>TECHNICAL SUMMARY</u>	
General View of PR155	4
<u>1. INTRODUCTION</u>	
1.1 GENERAL	7
1.2 MECHANICAL DESCRIPTION	7
1.3 MODULES	8
1.4 BRIEF TECHNICAL DESCRIPTION	9
1.5 CONTROLS AND INDICATORS	10
<u>2. INSTALLATION, SETTING UP AND OPERATION</u>	
2.1 INSTALLATION	12
2.2 SETTING UP	12
2.3 OPERATION	14
<u>3. CIRCUIT DESCRIPTION</u>	
3.1 RF FILTER UNIT	15
3.2 RF AMPLIFIER, MODULE 1	15
3.3 1ST MIXER, MODULE 2	16
3.4 1ST LOCAL OSCILLATOR, MODULE 3	16
3.5 SPECTRUM GENERATOR, MODULE 10	17
3.6 INTERPOLATING OSCILLATOR	17
3.7 MHz SELECTOR, TURRET COMPARTMENT 2	18
3.8 PHASE LOCK CIRCUIT, TURRET COMPARTMENT 3	18
3.9 1ST IF AMPLIFIER AND 2ND MIXER, MODULE 4	20
3.10 2ND IF AMPLIFIER AND 3RD MIXER, MODULE 5	20
3.11 10.6/10.8 MHz GENERATOR, MODULE 11	20
3.12 3RD IF AMPLIFIER AND DETECTORS, MODULE 7	21
3.13 AGC AMPLIFIER AND DETECTOR, MODULE 8	21
3.14 AUDIO AMPLIFIERS, MODULE 9	22
3.15 100 kHz DIVIDER AND CALIBRATE CIRCUIT, MODULE 12	23
3.16 BFO	23
3.17 ISOLATING AMPLIFIER	23
3.18 MAIN CHASSIS	23
<u>4. SERVICING</u>	
4.1 GENERAL	25
4.2 TEST EQUIPMENT	25
4.3 POWER SUPPLY	25
4.4 OVERALL RECEIVER GAIN	26
4.5 STAGE GAIN	26
4.6 PRODUCT DETECTOR AND LINE AMPLIFIER GAIN	27
4.7 AGC TESTS	28
4.8 SIGNAL/NOISE PERFORMANCE	28
4.9 AUDIO PERFORMANCE	29
4.10 CALIBRATION	30

4.11	OSCILLATORS	30
4.12	PHASE LOCK CIRCUITS	32
4.13	ISOLATING AMPLIFIER	34
4.14	METERING CIRCUITS	34
	<u>5. COMPONENT INFORMATION</u>	35
	<u>6. DRAWINGS AND ILLUSTRATIONS</u>	63

TECHNICAL SUMMARY

Frequency Range: 60 kHz to 30.1 MHz continuous coverage (will operate down to 15 kHz with slight degradation of performance).

Modes of Reception: CW (A1), MCW (A2), DSB (A3, A3H), USB, LSB (A3A, A3J, A3H), FSK (F1). One spare switch position for additional mode.

Frequency Stability: After 4 hour warm up at steady ambient, less than 30 Hz drift per hour.

Drift with change of ambient: Less than 40 Hz per °C after 5 hour warm-up.

Bandwidths:

<u>Filter</u>	<u>6dB point</u>	<u>60dB point</u>	<u>Shape</u>
150 Hz	150 Hz	1.8 kHz	Symmetrical
300 Hz	300 Hz	3.0 kHz	Symmetrical
1.4kHz	1.4kHz	5.5 kHz	Symmetrical
3.5kHz	3.5kHz	12.0 kHz	Symmetrical
6.0kHz	6.0kHz	18.0 kHz	Symmetrical
12.0kHz	12.0kHz	36.0 kHz	Symmetrical

Sensitivity: CW; 0.5 uV for a 20dB signal/noise ratio.
(up to 30.1 MHz) AM; 2.5 uV for a 10dB signal/noise ratio.
SSB; 0.5 uV for a 10dB signal/noise ratio.

Tuning: Thirty bands of 1 MHz each with an 84 inch scale-length for each band.
There is an overlap of 100 kHz at both ends of each band.

Tuning Accuracy: It is possible to set the tuning control to within plus and minus 10 Hz of a required frequency.

Scale Reading Accuracy: Not worse than plus and minus 500 Hz at any point in the 1 MHz band, when correctly calibrated at mid-band.

Calibration: Marker at 100 kHz points provided from the master 1 MHz oscillator and BFO check.

A.G.C.: Output constant within 3dB for approximately 130dB change in input level above A.G.C. threshold of 0.5uV e.m.f.

A.G.C. Time Constant:

	<u>Attack</u>	<u>Decay</u>
Short	10 m/s	100 m/s
Medium	10 m/s	1 sec.
Long	10 m/s	10 sec.

B.F.O.: Variable \pm 8 kHz with slow motion tuning and calibration facility.

RF Input: Nominal 75 ohms. Can accept, without damage, either signals up to 30V e.m.f. of 15 mins. duration with less than 1dB degradation in noise factor and 6V e.m.f. continuously.

IF Output: 100 kHz, 50mV into 75 ohms. Following IF selectively.

Audio Output: Internal Loudspeaker
Two 600 ohm headphone outputs. 150 or 600 ohm external line balanced or unbalanced.

Audio Output Level: 150 ohm line - 40 mW; 600 ohm line - 10mW
Loudspeaker - 400 mW; Headphones - 7mW

Noise Figure: Typically 8dB.

Audio Frequency Response: Within 4dB from 300 Hz to 12 kHz.

Meter Indication: May be switched to 'S' or audio level to line.

IF Rejection: 75dB.

Image Rejection: Not less than 80dB.

Internally Generated Spurious Responses: Less than equivalent 0.2 uV e.m.f. all responses except 1 MHz and 21.4 MHz which is less than 2uV e.m.f. equivalent between 400 kHz - 30.1 MHz.

Spurious Response to external signals: Better than 50dB for signals 10 to 35kHz of tune, better than 80dB for signals above 35kHz of tune.

Blocking: With receiver tuned to any frequency between 2 MHz and 30 MHz and a wanted signal level of 1uV e.m.f. the level of an interfering signal 10 kHz removed required to reduce the output by 3dB is greater than 400uV e.m.f. This level increases with the frequency separation.

Cross Modulation: With the receiver tuned to any frequency between 2 MHz and 30 MHz and a wanted signal level of 1mV e.m.f. the level of an interfering signal 10kHz removed required to produce cross-modulation 20dB down on reference (1mV 30% modulated) is greater than 80mV e.m.f. This level increases with the frequency separation.

Inband Intermod.: 2nd order - 30dB, 3rd order - 35dB.

Outoof Band Intermod.: With the receiver tuned in for cross modulation two interfering signals +65dB reference level producing $12\text{dB } \frac{S+N}{N}$ ratio and spaced +10kHz and +20kHz from tuned frequency produce an intermodulation product at the tuned frequency equivalent to a wanted signal reference level.

Power Requirements: 100V to 125V, or 200V, 48 to 520 Hz single phase or 24V d.c. floating supply or positive earth.
Power consumption 22W at 24V d.c. approx.

Environment: Operation - 20°C to + 50°C, 95% R.H.
Storage - 40°C to + 70°C, 95% R.H.

Dimensions and Weight: Width : Suitable for rack mounting.
Height : 7 in. Depth: 17 in. Weight: 38 lbs.

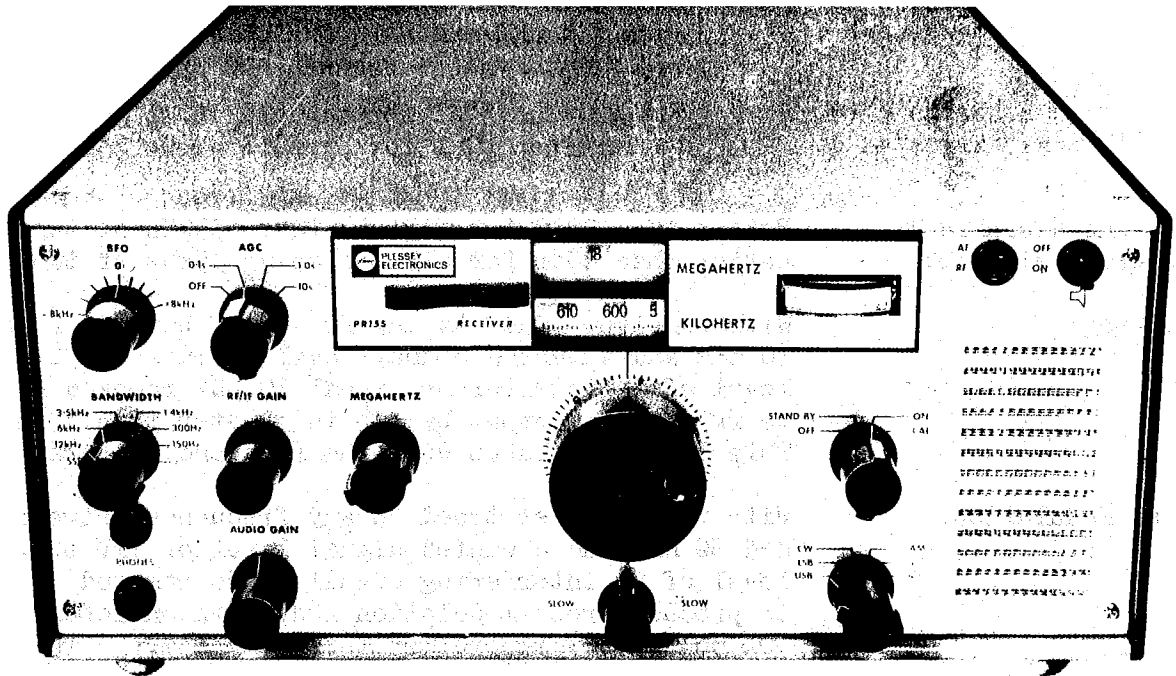

PR155 MF/HF Communications Receiver

1. INTRODUCTION

1.1 GENERAL

The PR155B MF/HF Receiver is an all transistor receiver designed for the reception of AM, CW, MCW, DSB, SSB or FSK signals in the frequency range 15kHz to 30MHz. Facilities can be provided to receiver other types of transmission, if required.

The receiver is of modular construction and is contained in a metal case which may be fitted with feet for desk use, or with brackets for mounting in a standard 19 inch rack or cabinet assembly. Brackets and feet are provided with the equipment together with the requisite securing screws and washers.

Protection circuits are incorporated in the PR155B which will enable continuous RF input signal of up to 6V EMF to be accepted without causing damage. The input circuit is arranged to match to a 75 ohm, unbalanced aerial system. The audio outputs available are two 600 ohm outputs suitable for operation of headsets and a 150 ohm and 600 ohm, balanced or unbalanced, external line output. An internal loudspeaker is fitted.

The a.c. version of the equipment is designed to operate from a 100 to 125V or 200 to 250V, 48 to 420 Hz single phase supply or an unearthed d.c. supply of 24V. Its power consumption is approximately 18W at 24V or 35VA at 240V, 50 Hz. A d.c. version, for operation on a 24V d.c., earthed, supply, is available.

1.2 MECHANICAL DESCRIPTION

1.2.1 General

The PR155B is of modular construction, consisting of fifteen standard modules assembled together on a main chassis assembly. Apart from RF connections, which are made with individual coaxial connectors, all connections between the modules and the chassis are made via the chassis wiring.

1.2.2 Main Chassis

The main chassis, with modules and sub-assemblies in position is illustrated in fig. 1.

Eleven of the modules are located in screened compartments above the main member of the chassis and connect with the chassis wiring via soldered contacts on the underside of the chassis. Pin contacts on the modules are soldered to contacts which are made to slide freely in their locating block in order that each may be individually unsoldered to facilitate module removal. Of the other four, the BFO, interpolating oscillator and turret modules are mounted above the main chassis member, the turret module protruding through from the underside, on which the isolating amplifier is mounted. Apart from coaxial connectors all interconnecting wiring is contained in a cableform below the chassis and behind the front panel.

All operational controls are mounted on the front panel. The MEGAHERTZ and tuning controls are coupled to the turret and interpolating oscillator respectively via Oldham couplers. On the rear panel are located the mains fuseholders, three link panels and the provisions for external connections to the receiver in the form of a plug, sockets and a terminal block.

1.3 MODULES

A list of the modules contained within the receiver is given below. Eleven of these are of similar construction consisting of one or two printed circuit component boards and designed to fit into screened compartments on the main chassis, the screening being completed by an end plate which also serves as a handle for the removal of the module. To aid identification, each of the modules is given a number as indicated in the list.

Item	Module No.	Part No.
RF Amplifier	1	630/1/17670
1st Mixer	2	630/1/14111
1st Local Oscillator	3	630/1/14112
Amplifier/2nd Mixer	4	630/1/14117
10.7 MHz Amplifier/3rd Mixer	5	630/1/17760
100 kHz Amplifier/Detector	7	630/1/17775
AGC Amplifier and Detector	8	630/1/17750
Audio Amplifiers	9	630/1/14119
Spectrum Generator MK II	10	630/1/14930
10.6/10.8 MHz Generator MK II	11	630/1/14938
100 kHz Divider and calibrate	12	630/1/14116
Interpolating Oscillator	-	630/1/14000/001
Isolating Amplifier (1)	-	630/1/14541
Isolating Amplifier (2)	-	630/1/14541/001
BFO	-	630/1/23304
Turret Assembly	-	630/1/14300
Regulator Assembly	-	630/1/14608
Shaper Board	-	630/1/17869
Meter Amplifier	-	630/1/17742

The turret assembly has three separate screened compartments containing the RF filter unit, MHz selector and phase lock circuits. The RF filter and MHz Selector Compartments (compartments 1 and 2) consist basically of rotary switch assemblies which are coupled to the MEGAHERTZ control. The components of their associated circuits are mounted on boards in the compartments or on the switch assemblies. Compartment 3, containing the phase lock circuits is on the under-side of the module and contains three printed circuit boards. (Boards G,H and J).

The interpolating oscillator, BFO and isolating Amplifier modules each consist of a screened box containing a printed circuit board. Tuning of the BFO is effected by means of a variable capacitor located inside one end of the module; the capacitor spindle protrudes through the front panel as the BFO TUNE Control. The drive to the interpolating oscillator tuning protrudes through one end of the module and is coupled via an Oldham coupler to the KILOHERTZ film scale drive.

1.4 BRIEF TECHNICAL DESCRIPTION (See Fig. 2)

Three stages of frequency conversion are used in the receiver, the intermediate frequencies being 37.3 MHz, 10.7 MHz and 100 kHz.

The receiver signal is filtered in one of eight sub-octave bandpass filters in turret compartment 1, the filter appropriate to the signal frequency being selected by the setting of the MEGAHERTZ control. After filtering the signal is amplified in a wideband amplifier (module 1). This amplifier incorporates a gain control loop which enables it to accept signal amplitudes in excess of 1V and at the same time maintain an output level compatible with minimum cross modulation and intermodulation products. The RF amplifier output is applied to the 1st mixer (module 2) in which it is mixed with the signal from the 1st local oscillator (module 3) for conversion to the 1st IF of 37.3 MHz.

The 1st local oscillator covers the frequency range 37.3 to 67.3 MHz. A free-running oscillator, capable of being tuned to any frequency within the range, is used and tuning is effected by a phase lock control loop.

A spectrum generator (module 10) provides signals at each MHz from 35 MHz to 64 MHz and signals for interpolation between these, to achieve the required local oscillator frequency, are produced by an interpolating oscillator, which is tunable over the range 2.2 MHz to 3.4 MHz. The spectrum generator output is fed into turret compartment 3m via compartment 2, in which the spectrum generator frequency appropriate to the frequency of the received signal is selected by means of tuned selective amplifiers, tuning being effected by selection of coils as a result of the turret setting, and only the required 'megahertz' signal is applied to compartment 3. In compartment 3, the signal from the interpolating oscillator is added to the megahertz signal to produce a synthesized signal at the desired local oscillator frequency.

Provision is made for the use of external oscillators in place of either or both of the interpolating oscillator and the 1 MHz oscillator which drives the spectrum generator.

The output from the 1st local oscillator is also fed into compartment 3 via an isolating amplifier. It is compared with the synthesized frequency to produce a control voltage which is used to tune the local oscillator exactly to the required frequency.

The 1st IF signal is filtered in module 2 by a crystal filter having a 12 kHz bandwidth. It is then amplified and mixed with a 48 MHz (2nd local oscillator) signal from module 10, for conversion to the 2nd IF of 10.7 MHz in the 37.3 MHz amplifier and 2nd mixer (module 4). A second crystal filter follows the 2nd mixer and the filtered 10.7 MHz output obtained is amplified and undergoes the final stage of frequency conversion, to 100 kHz in module 5. The 3rd local oscillator is the 10.6/10.8 MHz oscillator, module 11, the output from which which is dependent upon the mode of operation selected, being 10.8 MHz for USB operation and 10.6 MHz for other modes.

The 3rd IF signal is filtered by one of seven bandpass filters, the bandwidth being selected by the BANDWIDTH selector switch. The frequencies of the filters fitted in the receiver are 3 kHz (SSB), 150 Hz, 300 Hz, 1.4 kHz, 3.5 kHz, 6.0 kHz and 12 kHz.

Final IF amplification and detection takes place in module 7. A product detector is used for SSB and CW operation and an envelope detector for AM. The 100 kHz signal for carrier reinsertion on SSB is obtained from module 12 and a BFO is provided for CW operation.

An AF output from the detectors is applied to the audio amplifiers in module 9 which provide the receiver outputs.

AGC is applied to all IF amplifiers and the RF amplifier and is obtained from the AGC detector (module 8).

For calibration purposes, marker pips at 100 kHz intervals, derived in module 12 from the 1 MHz output of module 10, may be injected into the 1st mixer.

All stages of the receiver operate on a -15V d.c. supply. On mains operation, the a.c. supply is stepped down to 22V and then rectified by a bridge rectifier, the resultant d.c. being applied to the receiver circuits via a regulator circuit which maintains a -15V supply. For d.c. operation, the 24V d.c. (unearthed) is applied to the regulator circuit via the bridge rectifier; this method of connection protects all circuits against damage due to reverse polarity, since the rectifiers ensure that correct polarity is always observed.

1.5 CONTROLS AND INDICATORS

All functional controls and the monitoring meter are mounted on the receiver front panel. Selector links are located on the rear panel. The controls and their functions are detailed below:-

- Control switch, S1 : A four position switch, used to switch the receiver into one of the conditions OFF, STANDBY, ON or CALIBRATE.
- Mode selector switch S2 : The required mode of operation is selected by the setting of S2. Five modes are provided, USB, LSB, CW, AM and FSK. One extra switch position is provided to accommodate other modes, if required.
- MEGAHERTZ control : This control is used to set the turret to operate at the 'megahertz' appropriate to the frequency of the receiver signal. Indication of the selected frequency is given on a MEGAHERTZ film scale.
- Tuning control (kHz) : Used to tune the interpolating oscillator and drive the KILOHERTZ film scale to indicate the tuning setting. Fast or slow motion drive is available, dependent upon the setting of the SLOW/FAST/SLOW control below the tuning control.

BANDWIDTH switch S3 : The appropriate bandwidth is selected by this switch. (SSB, 150 Hz, 300 Hz, 1.4 kHz, 3.5 kHz, 6.0 kHz, 12 kHz).

AGC switch S4 : The receiver IF gain is controlled by the IF gain control when S4 is set to OFF and by AGC when S4 is set to 0.1 sec., 1 sec., or 10 secs.

BFO control : Used to tune the BFO by \pm 8 kHz about its nominal frequency.

AUDIO GAIN control (RV2) : Used to adjust the gain of the audio amplifier.

RF/IF GAIN control (RV1) :
 AGC off : Manual gain control.
 AGC on : AGC threshold control.

Loudspeaker ON/OFF switch, S5 : Used to switch the internal loudspeaker on or off.

Meter switch, S6 (AF/RF) : Used in conjunction with the meter (M1) to monitor the audio output or as an 'S' meter for tuning.

Selector links : A link is provided on the rear panel for selection of either a 150 ohm or a 600 ohm line output. Further links enable the internal oscillator to be disabled when external oscillators are to be used.

Indicator lamp ILP1 : This lamp is lit when the control is turned from the OFF position. (Located in M1).

2. INSTALLATION, SETTING UP AND OPERATION

2.1 INSTALLATION

2.1.1 General

When received, the PR155 should be inspected for signs of damage, with particular attention to the front panel meter and the correct mechanical operation of switches and controls. Remove the top and bottom covers by first removing the four securing screws and pushing the cover forward from the back of the receiver, and ensure that all coaxial connectors are mated correctly.

If the receiver is to be used on a desk, fit the four feet to the case, or, if it is to be mounted in a rack or cabinet, fit the mounting brackets. Suitable screws, with washers, are provided for both methods of mounting. When feet are to be fitted, the screws securing the bottom cover are removed and the cover then secured in position by the feet securing screws. Extension pillars are also provided to enable the receiver to be raised at the front if desired.

2.1.2 Supply connections

For mains operation, the supply is connected into the receiver at PL1 on the rear panel, using the mains socket provided. The connections to the socket are :-

Pole A - neutral

Pole B - line

Pole C - earth

For d.c. operation, a floating 24V supply should be connected to the appropriately coded terminals of the terminal strip on the rear panel.

2.1.3 Receiver terminations

Apart from the PHONES jacks on the front panel, other connections can be made at the sockets or the terminal strip on the rear panel, these are all coded according to their use.

2.2 SETTING UP

2.2.1 Power supply

The equipment is normally despatched from the manufacturers with the mains transformer tapplings wired for operation on 240V mains. Should any other mains supply voltage be used, change the connections and links to the transformer primary as shown below. Ensure that terminals 5 and 6 (D.C. + and -) on the terminal strip on the rear panel are linked and that the mains and 22V fuses are of the correct rating (1A for 200 to 250V operation and 2A for 100 to 125V operation

**MAINS
TRANSFORMER
TAPPINGS**

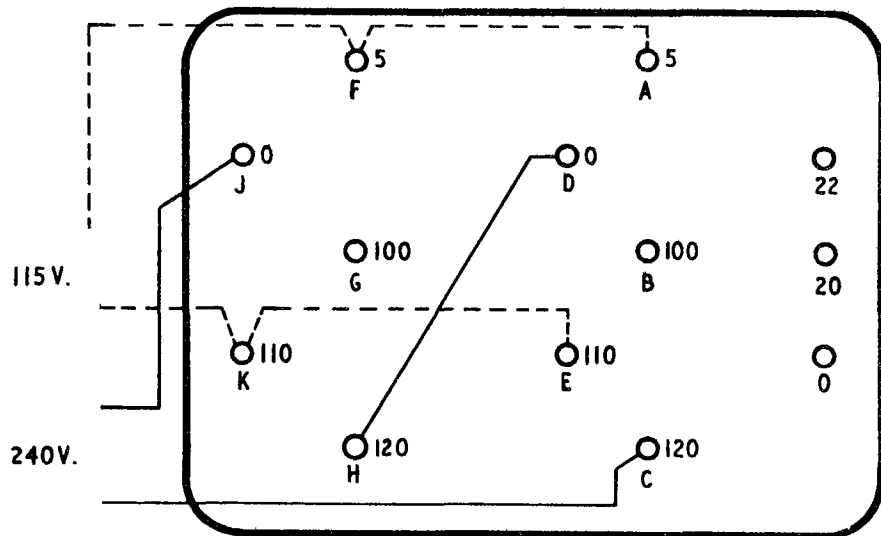

Voltage	Input to	Link
100	J & G	J to D and G to B
105	F & G	F to A and G to B
110	J & K	J to D and E to K
115	F & K	F to A and E to K
120	J & H	J to D and C to H
125	F & H	F to A and C to H

Voltage	Input to	Link
200	J & B	G to D
205	F & B	G to D
210	J & E	G to D
215	F & E	G to D
220	J & E	K to D
225	F & E	K to D

Voltage	Input to	Link
230	J & E	H to D
235	F & E	H to D
240	J & C	H to D
245	J & C	H to A
250	F & C	H to A

To operate on a 24V d.c. (unearthed) supply, connect this supply between terminals 5 and 6 of the terminal strip, having removed the link.

If the panel lamp is required to be used (A.C. or D.C. operation) link the terminals 3 and 4 (PANEL LAMP).

2.2.2 Link connections

If the internal 1 MHz oscillator and VFO (interpolating oscillator) are to be used, set the INT. 1 MHz and INT. VFO links to the ON position, but, if either or both is to be replaced with external oscillators, set the relevant link to OFF and inject the external oscillator output to the relevant socket on the rear panel. Make the appropriate coaxial connections, at the panel above the mains transformer, as follows:-

- Internal oscillators in use: cable 7 to cable 26
cable 28 to termination
- External 1 MHz oscillator in use. cable 28 to cable 24
- External VFO in use cable 7 to cable 25

Set the LINE OUTPUT IMPEDANCE link to the position appropriate to the impedance required.

2.2.3 External connections

Connect the aerial to the AERIAL socket and, if external oscillators are to be used, they should be similarly connected to the sockets provided on the rear panel. Make the necessary line output connections at the terminal block on the rear panel.

2.3 OPERATION

2.3.1 Normal operation

Set the receiver controls as follows:-

Mode selector switch: to the mode of operation required
BANDWIDTH switch: to the required bandwidth
AGC : to 0.1 sec. position for tuning; to 1 or 10 sec. position when on tune. The 0.1 sec. position may be used when on tune if rapid signal fading is experienced.
BFO : to 0
AUDIO GAIN : to mid-position
RF/IF GAIN : initially fully clockwise
Meter switch : to RF

Set the control switch to STANDBY and allow 10 minutes for the oscillators to stabilize. Switch to ON. Turn the MEGAHERTZ control until the "megahertz" portion of the frequency required is shown in the window. Turn the RF/IF GAIN anti-clockwise until the background noise in the speaker or headphones is reduced to tolerable level. Before selecting the "kilohertz" portion of the required frequency, first check the calibration of this portion of the film scale at the nearest 100 kHz point in the manner described in para. 2.3.2. The required frequency can then be tuned by rotating the main tuning control until the "kilohertz" portion is indicated on the KILOHERTZ film scale. If required, set the SLOW/FAST/SLOW control to SLOW and tune for maximum indication of the signal to be received using the tuning meter.

Adjust the AUDIO GAIN control for optimum level in the phones or loudspeaker.

If operating on CW, adjust the BFO control to obtain the tone required.

2.3.2. Calibration

To calibrate the KILOHERTZ film scale, first select USB or LSB on the mode selector switch and then set the control switch to CALIBRATE. Calibration pips will be heard at every 100 kHz when the receiver is tuned over the range of the tuning control, and the adjustable cursor can then be set to the appropriate scale marking at zero beat condition of the pips. Interpolation can be made between the 100 kHz markings on the scale to obtain accurate indication of the frequency of received signals.

NOTE: This calibration is valid for all modes but calibration pips are not obtainable on CW or AM.

To set the BFO, the mode selector switch should be set to USB, the control switch to CAL and tune for zero beat. Change the mode selector switch to the CW position and adjust the BFO to obtain zero beat. The BFO tuning control should indicate 0.

3. CIRCUIT DESCRIPTION

3.1 RF FILTER UNIT (Fig. 4)

The received signal is connected directly into the RF filter unit (compartment 1 of the turret assembly). The filter unit contains eight band-pass filters with pass bands as follows:-

FL1 - 0 to 2 MHz	FL5 - 6 to 9 MHz
FL2 - 2 to 3 MHz	FL6 - 9 to 14 MHz
FL3 - 3 to 4 MHz	FL7 - 14 to 21 MHz
FL4 - 4 to 6 MHz	FL8 - 21 to 30 MHz

When the MEGAHERTZ control is set to the MHz of the required frequency, the filter appropriate to that frequency is automatically selected, the filters being located between the turret wafers C and D which serve as selector switches. The filter inputs are connected to wafer D and their outputs to wafer C. From wafer C the signal is fed via the filter C2, L1 and SKT3/PL3 to the RF amplifier, module 1. The filter C2, L1 functions as an image rejector.

3.2 RF AMPLIFIER MODULE 1 (Fig. 5)

The RF amplifier comprises one stage of amplification (VT1) followed by three emitter follower stages, (VT2-4). It is preceded and followed by variable attenuators in the form of shunt diodes which are selected for high storage to prevent diode non linearity effects.

The front end diodes are controlled by a local a.g.c. loop (VT9 and VT10). The voltage which operates the control transistor is produced by VT10, which operates as a detector, with the signal from VT3 emitter applied to its base via C10, R16/C15.

Under no-signal, or very low signal conditions, VT9 is held non conducting since its base (via R36) and emitter is returned to the -15V line. Thus D1 and D2 cannot conduct and offer no attenuation to the input signal.

As the signal level increases to 20mV the detector action of VT10 drives VT9 base less negative with the result that VT9 conducts, drawing

current via D1 and D2, decreasing its impedance, thus applying some attenuation to the input signal. With further increases in signal strength VT9 draws more current via D1 and D2, increasing the attenuation.

The control circuit is prevented from responding to transient changes in signal level by capacitor C24.

The output from VT4 is applied via R19 to the second variable attenuator circuit and via C13 to the first mixer. The a.g.c. line from module 8 is applied to a control amplifier VT5 and VT6. This operates in a similar way to VT9 and VT10, as VT6 draws more current via D4 so the output signal is attenuated to maintain an output of approximately 30 mV to prevent overloading of the first mixer. Threshold adjustment is obtained by adjusting RV1 (approximately 150 μ V e.m.f. input signal).

3.3 FIRST MIXER, MODULE 2 (Fig. 6)

The signal input to module 2 is applied via a 30 MHz low pass filter (C1 to C7 and L1 to L3) to transformer T1, and the first local oscillator signal is applied to transformer T2. Transformers T1 and T2 are connected with diodes D1 to D4 in a ring bridge mixer configuration, the output from which, at the first IF of 37.3 MHz is filtered by the 37.3 MHz bandpass filter FL1 and applied to the first IF amplifier in module 4. When the control switch, S1 on the front panel, is set to CALIBRATE, markers at 100 kHz intervals throughout the frequency range are applied in place of the signal input for calibration of the receiver. Under these conditions the -15V supply to module 1 is switched off at S1.

3.4 FIRST LOCAL OSCILLATOR, MODULE 3 (Fig. 7)

The first local oscillator is a free-running oscillator employing VT1 in a Hartley type circuit. Tuning of the oscillator is effected by the preset capacitor C5 and the varactor diodes D1 and D2 in conjunction with the saturable reactor L1. The reactor current is controlled by the d.c. amplifier in the phase lock loop circuit (3.8) to provide a coarse adjustment of oscillator frequency and a finer, faster adjustment is provided by D1 and D2 under similar control.

The oscillator output is coupled via C4 to emitter follower VT2 which provides drive to two further emitter followers VT3 and VT4. VT3 provides an output to the phase lock loop circuits and VT4 to the first mixer.

3.5 SPECTRUM GENERATOR, MODULE 10 MKII (Fig.8)

This module contains a spectrum generator, generating signals at 1 MHz intervals in the spectrum 35 MHz to 64 MHz, and a 48 MHz selector circuit which selects the 48 MHz output from the spectrum generator for use at the second stage of frequency conversion.

A 1 MHz signal, normally taken from the associated PR1553 Receiver, is applied to VT3 base. It is amplified in VT3, VT4 and VT5 stages, but the output from VT5 is differentiated to produce harmonics at each 1 MHz interval throughout the spectrum 35 MHz to 64 MHz. These harmonics are coupled via emitter follower VT6 to the 48 MHz selector (board B) and to another emitter follower VT8 which provides the spectrum output to compartment 2 of the turret assembly (3.7) via the high pass filter C20, L1, C21. VT6 also feeds emitter follower VT7 which provides an output to the 10.6/10.8 MHz generator module 11.

The spectrum output from board A is injected at the emitter of the first of two transistors in a 48 MHz selector circuit on board B. The collector circuit of VT1 is tuned to 48 MHz by L1 and coupled to VT2 base. The feedback capacitor C2 improves the Q of the circuit such that it would oscillate freely at very nearly 48 MHz, thus the 48 MHz of the input signal is amplified and reproduced relatively free of all unwanted frequencies at VT2 emitter. From VT2 the 48 MHz output is filtered in L2 (tuned to 48 MHz), C4 and C5 and applied via VT3, an emitter follower, to a further selector circuit in module 4. The d.c. supply to VT1, VT2 and VT3 is locally stabilised at 10V by zener diode D2.

The 15V d.c. supplied to the spectrum generator and the 48 MHz selector circuits are each independently filtered in filter circuits contained on board B.

A 1 MHz oscillator circuit is also incorporated in this module but is not used in this application. It is disabled by setting the link on the rear panel of the receiver to INT. 1 MHz OFF.

3.6 INTERPOLATION OSCILLATOR (Fig.9)

The interpolating oscillator provides an output which is mixed with the selected output from module 10 to make up the first local oscillator frequency in order to control the first local oscillator at this frequency. It is tunable over the range 2.2 MHz to 3.4 MHz and the tuning is linear.

Transistor VT1 operates in a tunable oscillator circuit in which L1 is the variable component. Linearity of tuning is achieved in manufacture by adjustment of individual turns of L1 coil and final trimming is provided by L2 and C7. The output from VT1 emitter is coupled via an emitter to follower buffer stage VT2 to an amplifying stage VT3 and the amplified output is fed to turret compartment 3 (3.8) via a second emitter follower VT4. Output amplitude is adjusted by RV1 to a nominal 400mV r.m.s. The d.c. supply to the oscillator and buffer stage is stabilised to -10V by zener diode D1.

3.7 MHz SELECTOR, TURRET COMPARTMENT 2 (Fig.10)

The MHz selector circuit selects the required "megahertz" output from the spectrum generator (module 10) for mixing with the output of the interpolating oscillator. The circuit employed is identical in operation to that of the 48 MHz selector in module 10 (3.5) but the tuning coils (L1 and L2 in module 10) are selected in pairs from 30 pairs, according to the setting of the MEGAHERTZ control, to enable each megahertz output (from 35 to 64 MHz) from the spectrum generator to be selected. The output from this compartment of the turret is applied to the phase lock loop circuits in compartment 3. The d.c. supply is locally stabilised at -10V by zener diode D2.

3.8 PHASE LOCK CIRCUITS, TURRET COMPARTMENT 3

3.8.1 General

In the phase lock loop circuits, contained in compartment 3 of the turret, the outputs of the MHz selector and the interpolating oscillator are mixed to obtain an output at the sum of these frequencies, and the phase relation between this synthesized signal and the output of the first local oscillator is detected to provide a control voltage to lock the first local oscillator accurately to the required frequency. A sweep voltage to tune the local oscillator within the range of control of the phase lock circuits is generated in a multivibrator circuit.

Three boards (G, H and J) are contained in compartment 3, the circuits contained on each are described in 3.8.2, 3.8.3 and 3.8.4.

3.8.2 Phase splitters and modulator, board G (Fig.11)

The output from the MHz selector (3.7) is applied via a matching network to the base of VT5. Phase shift networks R23, C15 and R22, C13, C14 are connected between emitter and collector of VT5 and the component values are such that two outputs differing in phase by 90 degrees are obtained. One of these outputs is amplified in VT4 and applied to T2 and the other is amplified in VT6 and applied to T4. The output of the interpolating oscillator is applied to a circuit similar in operation to that of which the MHz selector output is applied. This circuit employs VT1, VT2 and VT3 and drives T1 and T3.

Transformers T1 to T4 and diodes D1 to D8 form two ring modulator circuits whose outputs are connected together via RV1. Due to the 90 degree phase difference between the modulator inputs, the difference frequency element of their outputs is cancelled out when they are connected together whilst the sum frequency elements are added. Thus a signal whose frequency is the sum of the two input frequencies is obtained at RV1 slider. Adjustment of RV1 enables any difference frequency, resulting from inequality of the difference frequency outputs from the modulators, to be cancelled out. The sum frequency output from RV1 is applied as a synthesized local oscillator frequency via emitter follower VT8 to board H.

3.8.3 Phase detector, Board H (Fig.12)

The first local oscillator signal from the isolating amplifier is transformer coupled via T1 to the base of VT1 and thence via VT2 and T2 to VT3 base. Transformers T1 and T2 are connected to provide 2 to 1 step-up ratio. VT3 drives transformer T3 to provide a reference signal, at the local oscillator frequency, to the phase detector diodes D1 to D4 to turn the diodes on and off on alternate half cycles.

The synthesized frequency output, at the required local oscillator frequency, is applied via a high pass filter circuit to the base of VT8 and the amplified output from VT8 collector is coupled via emitter follower VT7 to a second amplifier VT6, whose output is limited by the clipping diodes D5 and D6 and applied via two emitter followers, VT5 and VT4, to the phase detector.

When the two inputs to the phase detector are in quadrature, zero output is obtained and the output rises to a maximum in one polarity when the signals are of the same frequency and exactly in phase and in the other polarity when they are exactly anti-phase. The output from the detector is integrated by R8, C5 and then applied to the amplifier on board J.

3.8.4 D.C. Amplifier and reactor sweep generator, Board J (Fig.13)

A sweep voltage, whose mean level is variable according to the setting of the MEGAHERTZ control, is generated by a multivibrator in order to sweep the first local oscillator through the required frequency. The multivibrator employs transistors VT8 and VT9, whose collectors are returned to earth via a tapping on the resistance chain on wafer E of turret compartment 2 to control the mean level of the output from VT9 collector. The amplitude of the output from VT9 collector can be preset by adjustment of RV2. The square wave voltage at the collector of VT9 is integrated by R21, C4 to produce an approximation to a sawtooth waveform. This sawtooth is applied to the base of VT6, which, operates with VT5 in a differential amplifier circuit. Assuming no input to VT5 base, the sweep waveform appears at its collector and is directly coupled to VT7 base, controlling the emitter current. This current is drawn via one winding of the saturable reactor in the first local oscillator, sweeping the local oscillator frequency about the required frequency.

Transistors VT1 and VT3 are connected as a differential amplifier in which the total current drawn is maintained constant at a level controlled by VT2 and determined by the setting of RV3, the voltage across RV3 being clamped by zener diode D1. Balance of the amplifier is preset by the setting of RV1 to give equal collector voltages. The output from the phase detector (board H) is applied between the transistor bases, but VT3 base is clamped by D1. Thus, antiphase voltages are developed at the two collectors when the local oscillator frequency is the same as the synthesized frequency obtained from board H. The amplitudes of these outputs are affected by the transistor characteristics and are not necessarily equal, the most suitable output is selected by the setting of a link in manufacturing tests. The selected output is coupled to the base of emitter follower VT4 and the voltage developed at VT4 emitter is connected to D1 and D2 in the first local oscillator to provide a fine control of oscillator frequency.

The emitter of VT4 is also directly coupled to VT5 base to oppose the sweep voltages at VT6 base and thus maintain a constant current through VT7, i.e., through the saturable reactor.

To summarize: the sweep voltage sweeps the local oscillator towards the frequency required; when this frequency is equal to the synthesized frequency a voltage is developed to provide accurate tuning and at the same time the reactor current is clamped at the value appropriate to this frequency. Thus the local oscillator is swept quickly on to frequency and held for the duration of each sweep from the multivibrator.

3.9 FIRST IF AMPLIFIER AND SECOND MIXER, MODULE 4 (Fig.14)

The 37.3 MHz first IF output from the first mixer in module 2 is applied via C3, D1 and C5 to the base of the first of two IF amplifiers VT1 and VT2 on board A of the module. Diode D1 has the AGC reference voltage (3.12) applied to its cathode and the AGC voltage (3.13) applied to its anode; it therefore introduces increasing impedance into the input circuits as the signal strength increases. The AGC and reference lines are isolated from the first IF by L1 and L2. The overall gain of the two IF amplifiers is controlled by the preset potentiometer RV1, which is adjusted on test for optimum output level. The output from the second stage VT2 is coupled into the second mixer via a 37.3 MHz low pass filter. Links are provided in the filter circuit to facilitate alignment.

The output of the 48 MHz selector circuit in module 10 is injected at the emitter of VT5 on board B. This transistor, in conjunction with VT6, operates in a similar circuit to that of VT1 and VT2 of the 48 MHz selector circuit, except that the output from VT5 is directly coupled to the next stage, to provide a 48 MHz output which has extremely low spurious content. The signal developed at VT6 emitter is coupled via emitter follower VT7, C30 and R34 to the second mixer on board A.

The second mixer employs transistors VT3 and VT4 in a conventional balanced mixer configuration. The first IF signal, at 37.3 MHz is applied to VT3 base and VT4 emitter and the 48 MHz signal from VT7 is applied to VT3 emitter and VT4 base. Consequently, the signals are mixed and appear across the common collector load R23. The required second IF of 10.7 MHz is selected in the crystal bandpass filter FL1 and coupled via C25, R28 to the second IF amplifier in module 5.

3.10 SECOND IF AMPLIFIER AND THIRD MIXER, MODULE 5 (Fig.15)

The first stage (VT1) of the second IF amplifier in module 5 is similar to the first stage of the third IF amplifier, in Module 7 (3.12). VT1 is connected across the reference and AGC lines. As the emitter load of the stage is very much greater than the collector load the stage gain would approach unity, however, D2 controls this gain. During the reception of weak signals it is forward biased, but its impedance increases as the signal strength increases.

The output from VT1 is amplified by VT3 and this stage feeds the third mixer VT4 and VT5. The 100 kHz second IF signal is applied to VT4 base and VT5 emitter and the signal from the 10.6/10.8 MHz generator, module 11, is applied to VT5 base and VT4 emitter. The resultant 100 kHz output is coupled via C15, emitter follower VT6 and the bandwidth filter selected by the setting of S3, to the 100 kHz amplifier in module 7.

3.11 10.6/10.8 MHz GENERATOR MODULE 11 MKII (Fig.16)

The circuit accepts a spectrum output from the Spectrum Generator module 10 and provides an output at either 10.6 or 10.8 MHz to the third Mixer module 5.

The spectrum input is applied to the selector circuit VT1/2. This circuit, which is controlled by the LSB/USB bias network RV1/C7/R6/D8/C5 via S1BF, selects either 53 MHz for LSB or 54 MHz for USB. The required frequency is passed via the emitter follower VT3 to a divide-by-five circuit, VT4 to VT13.

The divide-by-five circuit is a ring counter type circuit from which only the output of the last transistor is taken. Two and a half input cycles are therefore required to cause bistable VT12/13 to change stage and provide one half cycle of output, thus five input cycles will be required to provide one complete output cycle. The output from VT13 is a square wave at one fifth of the input frequency, i.e. 10.6 or 10.8 MHz.

The square wave output from VT13 is passed to VT14. L3 and C15 in the collector of VT14 form a filter centred on 10.7 MHz, which will pass 10.6 to 10.8 MHz. This circuit also converts the square wave output from VT13 to a sine wave suitable for application to the 3rd Mixer, module 5, via SKT15.

3.12 THIRD IF AMPLIFIER AND DETECTORS, MODULE 7 (Fig.17)

The input circuit of VT1, the first stage of the third IF amplifier, includes an AGC controlled diode similar to the input circuits of modules 4 (3.9) and 5, but in this case the gain of the first stage is also controlled by AGC. Since the emitter load of VT1 is considerably greater than the collector load, the gain of the stage would approach unity, however, diode D2 is included in the circuit to control this gain. It is connected between the reference and AGC lines such that it is forward biased during reception of weak signals but its impedance increases with increase in signal strength. Thus, during reception of weak signals, VT1 emitter load impedance is reduced by the parallel path C4, D3, R10 and the gain of the stage is greater than when the diode impedance is increased by AGC action. Zener diode D3, connected between -15V and earth in series with R10 provides the AGC reference voltage of 4.7V with respect to earth.

The output from VT1 is amplified in three similar stages, VT2, VT3 and VT4 and applied to emitter follower VT5. This stage provides an output via C20, R46 to the AGC amplifier, module 8, and also drives a second emitter follower VT10 which provides outputs to the detectors and the 100 kHz OUTPUT socket on the receiver rear panel. The gain of the amplifier is controlled by RV1 placed between VT2 and VT3.

Two detectors are contained in this module, a product detector for SSB and CW operation and an envelope detector for AM operation. The product detector, employs transistors VT6 and VT7 together with transformers T1 and T2 in a conventional detector circuit. The -15V d.c. supply is connected to the circuit when USB, LSB or CW are selected at S2, while the 100 kHz signal from module 12 (3.15) is injected into the transistor emitter circuits for carrier reinsertion on SSB operation and the BFO (3.16) output is similarly injected on CW operation. The detector output is coupled via R44, C34 to the base of amplifier VT9. A conventional detector circuit is also used for AM operation; it is energised when AM is selected at S2. The output from VT10 is amplified in VT8, detected by D4 and the resulting audio frequency signal filtered and applied to VT9 base. VT9 is energised under all operating conditions to provide the AF signal output to the emitter followers VT10 and VT11 and hence to the audio amplifiers in the module 9 (3.14) and to the AUDIO GAIN control, RV2 on the main chassis.

3.13 AGC AMPLIFIER AND DETECTOR, MODULE 8 (Fig.18)

Module 8 is an AGC amplifier and detector which in conjunction with the AGC decay shaper board provides the main AGC control for the receiver.

The signal level at which AGC action starts to be effective is set by threshold control potentiometer RV1. This is then applied to VT1 which is an emitter follower stage, the output of which is applied to amplifying stage VT2. Transformer T1 in the collector load of VT2, provides impedance matching and

offers some selectivity to the circuit. Components VT3, D1, R8 and C5 form the detector and voltage doubler stage. A sinusoidal signal across C3 is rectified and amplified and the resultant d.c. voltage applied to the base of VT4 and further amplified.

Diodes D3, D4, D5 and R13 provide a two stage rise time circuit. The first portion of the signal rise causes the diodes to conduct heavily, but as the voltage across C8 approaches that of the signal, the diodes will switch off. R13 and RV2 control the rise time at the leading edge of the signal, thus preventing instability whilst not affecting the overall rise time.

VT7, VT8 and VT9 are emitter followers, the IF gain control is applied to the base of VT9 and controls the AGC level.

VT5 and VT6 provide overshoot limiting and noise pulse projection should the signal rise sharply. D2 will conduct and charge up C6. The sudden rise will cause the AGC to cut off the front end of the receiver and thus no signal will appear at the emitter of VT5; at this instance C6 will discharge and cause VT6 to conduct and feed a signal back into the circuit.

When the AGC is switched off the -15V to VT9 is removed and therefore there will be no AGC outputs, the gain being set by the RF/IF gain control.

D7 and D8 in the absence of a signal, prevent C8 from discharging to below 3.3 volts.

3.14 AUDIO AMPLIFIERS, MODULE 9 (Fig.19)

Two audio amplifiers are contained in module 9; one, feeding the PHONES jacks and the internal speaker, is on board A, and the other, providing the line outputs, is on board B. Both boards are supplied with -15V and are separately decoupled to prevent interaction.

The input to board A is from the slider of the AUDIO GAIN control on the main chassis of the receiver, it is applied to the base of VT1 via C1, R1. Negative feedback is applied to VT1 base, via C3. Two signals are obtained from VT1 collector circuit to drive VT2 and VT3, the first two transistors in a complementary, single-ended push-pull configuration of which VT4 and VT5 are the output transistors. In order to obtain the anti-phase signals for application to VT4 and VT5, a PNP transistor is used for VT2 and an NPN for VT3. The correct bias for Class AB operation of the push-pull drivers is obtained by adjustment of RV2, while RV1 is adjusted to equalise the supply voltages across the two push-pull sections. Temperature compensation is provided by D1 and D2 in the collector load of VT1.

The input to board B is direct from module 7; it is coupled to the base of VT1 via F1, C1. VT1 operates as an amplifier, with negative feedback introduced by R5, to provide an output at the slider of a preset gain control RV1 to drive the phase splitter VT2. One output, from VT2 emitter, is coupled via R10, C6 to the base of VT3 and another, from the collector of VT2, is coupled via C7 to VT4 base. Transistors VT3 and VT4 operate in a single-ended, Class A, push-pull circuit to drive the line output transformer T1, on the main chassis, via C8. Balance of the output stages is achieved by the setting of RV2 in VT3 base circuit.

3.15 100 kHz DIVIDE AND CALIBRATE CIRCUIT, MODULE 12 (Fig.20)

Module 12 contains the circuits which, from a 1 MHz input from module 10 or an external oscillator, produce the 100 kHz required for carrier reinsertion on S.S.B., and the 100 kHz markers used for receiver calibration.

The 100 kHz output is derived from a divide-by-ten integrated circuit ML1. The 4.7 volt H.T. required by ML1 is obtained from the zener diode L1 via R24. The 1 MHz input is amplified and limited by VT1, and coupled to ML1 pin 1 by the common collector stage VT2. The output of ML1 is taken from pin 12, as a square wave, and fed via the low pass filter, L₂ and C7 to the S.S.B. detector circuits (module 7) and via C8 to the base of the calibrate amplifier VT3. Following amplification in VT3, the signal is clipped by D3, differentiated and then injected into the first mixer (when CALIBRATE is selected at S1) for calibration purposes.

3.16 B.F.O. (Fig.21)

The BFO is energised when the mode selector switch, S2, is set to CW. It consists of an oscillator stage VT1 followed by an emitter follower VT2 which feeds the oscillator output to the product detector in module 7, via S2, for CW operation. The oscillator operates at a nominal 100 kHz and is tunable by +8 kHz about 100 kHz by means of the front panel BFO control, C9. The output amplitude is adjustable by means of the preset control RV1.

3.17 ISOLATING AMPLIFIERS (Fig.22)

The isolating amplifiers provide buffer stages between the first local oscillator and the phase lock loop circuits and prevent spurious oscillation. They consist of an amplifier stage, VT1 and an emitter follower, VT2. The local oscillator signal is injected at VT1 emitter in the first isolating amplifier and the signal from the second isolating amplifier, VT2 emitter, is coupled to the phase lock circuits via C5, R8.

3.18 MAIN CHASSIS (Fig.1)

3.18.1 Power Supply

On mains operation, the primary power supply is routed to the mains transformer, T2, via FS1 and the double pole toggle switch section of the control switch S1. The primary of T2 is in two sections, each with tappings to permit operation on any of the prescribed mains voltages. The 22V output from T2 secondary is applied via FS2 to the bridge rectifier MR1. The DC output is smoothed by C2 and applied to the receiver circuits via a voltage regulator. A conventional regulator circuit is used, employing VT4 with a reference voltage obtained from zener diode D1 (5.6V). Transistor VT4 is followed by two emitter followers VT3 and VT2 which drive the series regulator transistor VT1.

On d.c. operation, a floating d.c. supply is connected at terminals 5 and 6 on the terminal strip on the receiver rear panel and is thus connected into the regulator circuit via T2 primary, F2 and MR1. This method of connection, provides protection by F2 and avoids the possibility of damage in the event of reversed polarity of the input, since correct polarity of the input to the regulator is ensured by MR1.

The output from the regulator, at -15V d.c. is connected to the common pole of S1AF.

3.18.2 Switching circuits

Control Switch S1

When S1 is set to STANDBY, -15V is connected via S1AF to the 1 MHz oscillator in module 10 and to the interpolating oscillator only; at the same time the output of the calibrate circuit in module 12 is earthed. In the ON position of S1, the receiver is operational and all circuits, with the exception of the calibrate circuit in module 12 are supplied with -15V. When S1 is moved to

CALIBRATE, the -15V supply to module 1 is broken at S1AB the output from module 12 calibrate circuit is applied via S1AB to module 2 and the calibrate circuit is supplied with -15V via S1AF.

Mode selector switch, S2

Wafer S2AF switches the -15V supply to the oscillators in module 11 to energise the relevant circuit for USB or other modes of operation. Module 12 is supplied with 015V via S2AB on USB or LSB operation and the BFO is similarly supplied on CW operation. The -15V supply is switched to the relevant detector circuit in module 7 via S2BF. The fourth wafer, S2BB, is used to switch either the 100 kHz output from module 12, or the B.F.O. output, to module 7 on SSB or CW operation respectively.

BANDWIDTH switch, S3

This switch is used to select the filter appropriate to the bandwidth required.

AGC switch, S4

The AGC switch S4 has four positions, these being OFF, 0.1 sec., 1.0 sec., and 10 sec. In the AGC OFF position the 15V supply to the main AGC amplifier is removed and the receiver gain is controlled by RV1, the RF/IF gain control RV1 may be used as a threshold control when the AGC is set to any of the operating positions.

The 1.0 sec. and 10 sec. decay times are controlled by a shaper board which linearises the AGC characteristic. The 0.1 sec. decay time is primarily intended for tuning purposes.

Other switches

The loudspeaker ON/OFF switch, S5, is used to isolate the loudspeaker when it is not required. dummy load, R6, is connected in place of the loudspeaker when S5 is at OFF to maintain the loading of the audio amplifier and prevent the level at the PHONES jacks from rising.

For metering purposes, the AGC line and the audio output are connected via a resistor and a rectifier diode to poles of the meter switch S6, the required rectified signal is selected by S6 and applied to the meter M1.

3.18.3 Selector links

Selector links on the receiver rear panel are provided to enable the required line output impedance to be selected and in order that the internal oscillators may be disabled when external oscillators are to be used. The line output impedance selector link is used to connect an appropriate resistor (R2) or a link in series with the line output transformer (balanced line) or the unbalanced line output terminal.

3.18.4 Meter Amplifier

The meter amplifier board provides circuits for the following functions:-

- (1) Audio Output Level adjustments
- (2) AGC Threshold adjustment
- (3) Provision of RF/IF Gain control voltage

The audio input is applied at terminal 9 via R1 and C1 to rectifier D1. The d.c. is routed via RV1 and terminals 1 & 6 to the amplifier VT1, the amplified

voltage being applied to the meter via terminal 3. RV1 is used to adjust the audio output to the required level.

The AGC voltage is applied via terminal 4 to R2 and thence via terminals 5 & 6 to the amplifier VT1. The AGC threshold level is adjusted by RV3 which sets the level of VT1 emitter. The voltage is read at the meter via terminal 3.

Zener D3 provides 12V at terminal 7 for the RF/IF gain voltage which is applied to modules via the RF/IF gain control RV1.

The AF/RF selector switch selects terminals 1 or 5 of the board.

RV2 is the meter shunt and D4/D5 provide temperature compensation for the network R8, R9, RV3, R10, D3.

4. SERVICING

4.1 GENERAL

The information provided in this section is designed to assist in location of a fault to a particular module of sub-assembly and enable adjustment of certain preset controls using items of standard commercial test equipment.

4.2 TEST EQUIPMENT

Test equipment, as detailed below, is required for the tests detailed in this volume:

- (a) Multimeter 8SX CT497-6625-99-943-1524.
- (b) 75ohm Resistor - 3 in No. 5905-99-013-5463.
- (c) Multimeter Electronic CT471-6625-99-972-0247.
- (d) Signal Generator CT452A-6625-99-580-6581 and Signal Generator CT433A-6625-99-195-4684.
- (e) Multimeter Electronic CT471-6625-99-972-0247.
- (f) 600ohm Resistor - Use 2 in No. 5905-99-022-1166, 300ohm.
- (g) 560ohm Resistor 5905-99-013-5484.
- (h) Counter Electrical Frequency CT488-6625-99-971-8519.
- (j) Signal Generator CT433A-6625-99-195-4684.
- (k) Oscilloscope, CT436-6625-99-914-2605 (no storage facility).

4.3 POWER SUPPLY

The D.C. supply to the receiver circuits should be -15V to -16V with the control switch set at STANDBY and at ON. This can be measured at pin 4 or pin 6 of most of the modules.

4.4 OVERALL RECEIVER GAIN

The overall gain of the receiver may be tested in the following manner:-

- (a) Set AGC to OFF, BANDWIDTH to 3 kHz SSB and the mode selector switch to USB. Switch on the receiver and adjust the RF/IF GAIN control to maximum.

(b) Connect a valve voltmeter across the 100 kHz OUTPUT socket and connect the output of a signal generator to the 75 ohm AERIAL socket.

(c) Adjust the signal generator for an output of 0.5uV EMF at 15 MHz and tune the receiver for maximum indication on the valve voltmeter. An indication of approximately 80mV r.m.s. should be obtained.

(d) Repeat (c) at 30 MHz and 1 MHz respectively. An indication between 70 and 120mV r.m.s. should be obtained.

(e) If satisfactory results are obtained, proceed to 4.6.

4.5 STAGE GAIN

4.5.1 Measurement and adjustment

Should the overall receiver gain as measured in 4.4 not be satisfactory, the stage gain may be verified, and if necessary adjusted as detailed below. Set the BANDWIDTH switch to 6 kHz.

(a) Module 7

Set the AGC switch to 0.1 sec. and the control switch to ON. With no input signal into the receiver, measure the voltage on the AGC line (pin 3 on module 4, 5 or 7) relative to chassis. Switch the AGC OFF and adjust the RF/IF GAIN over its full range. The voltage measure on the AGC line should vary between at least 3.4 and 6.5V. Turn the RF/IF GAIN fully clockwise. Set the Mode Selector switch to AM and break coaxial cable 16 (input to module). Inject a signal at 100 kHz unmodulated at an e.m.f. of 250uV into module 7. Connect a valve voltmeter across the IF output socket which should be unloaded and adjust RV1 on module (accessible through the module handle) so that the output is 78 to 83mV e.m.f. Failure to obtain this output would indicate a fault in module 7. If a satisfactory result is obtained, lock RV1, reconnect cable 16 and proceed.

(b) Module 5, module 11 and bandwidth filter

Break cable 13, joining modules 4 and 5, and inject an unmodulated 10.7 MHz signal, at an EMF of 25uV into the cable attached to module 5. Tune the input signal for maximum indication on the valve voltmeter. Adjust RV1 on module 7 for a reading of 78 to 83mV r.m.s. Lock RV1.

(i) Should a reading of 78 to 83mV not be obtainable, a fault in module 11 or the selected bandwidth filter is indicated. Module 11 tests are detailed in 4.11.2. A fault in the filter can be verified by repeating the test with the BANDWIDTH switch set to 3.5 kHz.

(ii) If satisfactory results are obtained, remove the input, reconnect cable 13 and proceed.

(c) Modules 4 and 10

Break cable 11, joining modules 2 and 4, and inject an unmodulated 37.3 MHz signal at an EMF of 1.5 μ V into module 4. Tune the input signal for maximum indication on the valve voltmeter. By adjustment of RV1 on module 4 (through the module handle), set the output to 73 to 80mV r.m.s.

(i) If it is not possible to obtain the necessary output then a fault in module 4 or module 10 is indicated. Module 10 testing is detailed in 4.11.3.

(ii) If satisfactory results are obtained, lock RV1, remove the input and proceed.

(d) Modules 2 and 3

Terminate cable 11 from module 2 with a 75 ohm resistive load and connect a valve voltmeter across the load. Break cable 10, connecting modules 1 and 2, and inject an unmodulated 1 MHz signal, at an EMF of 100mV, into module 2. Tune the receiver for maximum indication on the valve voltmeter. An indication of not less than 15mV should be obtained.

(i) If a 15mV output is not obtainable, a fault is indicated in module 2 or the first local oscillator circuits (see 4.11.1).

(ii) If a satisfactory result is obtained, reconnect cable 11 and proceed.

(e) Module 1

Terminate cable 10 from module 1 with a 75 ohm resistive load and connect a valve voltmeter across the load. Break cable 3, connecting module 1 to the turret, and inject an unmodulated 1 MHz signal, at an EMF of 1mV into module 1. Tune the input for maximum indication on the valve voltmeter; this indication should be not less than 5mV. Unsatisfactory results indicate a fault in module 1.

4.5.2 Final Test

If satisfactory results are obtained in all of the stage gain tests repeat 4.4.

(a) Should the overall gain still be unsatisfactory, a fault in the RF filter (turret compartment) or the aerial input circuit is indicated.

(b) If the overall gain is slightly high, adjust RV1 on module 4 to obtain the correct overall gain when the receiver is tuned to 15 MHz.

4.6 PRODUCT DETECTOR AND LINE AMPLIFIER

Test the product detector and line amplifier gain in the manner detailed below:-

(a) CW

Connect a 600 ohm load between the 600 ohm output terminals on the rear panel and connect a valve voltmeter across the load. Set the selector link on the rear panel for 600 ohms output. Set the AGC to 0.1 secs, the MODE to

CW and the BANDWIDTH to 300 Hz. Apply a 15 MHz signal at 0.5 μ V and tune the receiver to give a maximum output from the 100 kHz IF. Adjust the BFO to give a 1 kHz output (using the internal speaker as monitor). Set RV1 on module 9B (accessible through handle) to the fully clockwise position and measure the audio output voltage using a valve voltmeter. This should not be less than 2.45V r.m.s. (10mW in 600 ohms).

(b) AM

Increase the signal level to 3 μ V e.m.f. and modulate with a 1 kHz tone at 30%. Switch to AM and select a 6 kHz filter. Measure the AF output which should not be less than 2.45V r.m.s.

(c) SSB

Remove the modulation and return the signal level to 0.5 μ V. Select the USB mode and tune the receiver to give approximately 1 kHz tone from line. Measure the output which should be not less than 2.45V r.m.s.

4.7 AGC TESTS

4.7.1 Threshold Levels

(a) Set the AGC switch to 0.1 sec and the mode switch to USB. Switch to SSB bandwidth and adjust the RF/IF gain control to maximum. Inject a signal of 0.5 μ V e.m.f. at 15 MHz into the 75 ohm AERIAL socket, and adjust RV1 on module 8 for a 65 mV e.m.f. at the 100 kHz output (unloaded). Note the audio output level across the 600 ohm line.

(b) Raise the input signal level in 10dB steps by 120dB. The audio output level should not vary by more than 4 dB above the reading obtained in (a).

4.7.2 Decay Times

To check the decay times proceed as follows:-

(a) With the conditions as in 4.7.1 (a) above, set the AGC switch to 1.0 secs and connect an Avo between the A.G.C. line and earth. Set the signal generator to +80dB above 0.5 μ V. Switch out 40dB manually, and note the time it takes the A.G.C. voltage to decay, this should be approximately 1 second.

(b) Repeat the procedure with the A.G.C. set to 10 seconds. The decay time should be approximately 10 seconds.

(c) If these results cannot be obtained adjust RV1 on the A.G.C. Shaper Board until satisfactory results are obtained.

4.8 SIGNAL/NOISE PERFORMANCE

Measure the signal/noise performance of the receiver as follows:-

(a) Set A.G.C. to OFF, BANDWIDTH to 6 kHz and select the AM mode. Turn both gain controls fully clockwise.

- (b) Inject a 150 kHz unmodulated signal at a level of $8\mu\text{V}$ at the 75 ohm aerial socket. Tune the receiver at 150 kHz for maximum noise output. Adjust the AUDIO GAIN control for a convenient output level on the millivoltmeter connected across the 600 ohm line output and note this level. Apply modulation at 1000 Hz to a depth of 30% to the input signal. The audio output should increase by at least 10dB.
- (c) Set BANDWIDTH to SSB and select the USB mode.
- (d) Increase the input signal frequency to 15 MHz and set the level to $2\mu\text{V}$. Tune the receiver to obtain an audio output of approximately 1 kHz. Set IF GAIN to maximum and adjust AUDIO GAIN for a convenient reading on the millivoltmeter. Note the reading, then remove the input signal; the meter reading should fall by not less than 20dB.
- (e) Select the LSB mode. Without resetting any other receiver controls, inject a 14.998 MHz at $2\mu\text{V}$. Verify that an audio output of approximately 1 kHz is obtained and that the millivoltmeter reading again falls by not less than 20dB when the input signal is removed.
- (f) Set BANDWIDTH to 300 Hz and select the CW mode. Inject a signal at 15 MHz and a level of $2\mu\text{V}$. Adjust the BFO control to obtain an audio output at approximately 1 kHz. Note the output level. Remove the input signal; the output should fall by not less than 26dB.
- (g) Set BANDWIDTH to 6 kHz and select AM. Apply a 1 MHz signal, at a level of $3.8\mu\text{V}$ modulated to a depth of 30% at 1 kHz to the 75 ohm aerial input. Adjust AUDIO GAIN for a convenient reading on the millivoltmeter and note the reading. Remove the modulation from the input signal; the output should fall by not less than 10dB.

4.9 AUDIO PERFORMANCE

4.9.1 Output levels

To measure the audio output levels, apply a 15 MHz signal at $200\mu\text{V}$ at the 75 ohm aerial socket, modulate the input signal with 1 kHz to a depth of 90% and, with AGC ON, tune the receiver to the input signal; then proceed as follows:-

- (a) Set the loudspeaker switch to OFF. Connect a valve voltmeter between the centre pole of this switch and chassis. Set AUDIO GAIN to maximum; the valve voltmeter should indicate not less than 2.45V r.m.s. (400mW in 15 ohms). Remove the meter.
- (b) Load each phone jack in turn with 600 ohms and measure the voltage across the load; it should be not less than 2.0V r.m.s. (6.7mW in 600 ohms).
- (c) Set RV1 on board B of module 9 fully clockwise and the line output links for a 600 ohm line output. Load the balanced line output with 600 ohms and measure the voltage across the resistor, it should be not less than 2.45V r.m.s. (10mW in 600 ohms).
- (d) Remove the 600 ohm load and set the links for 150 ohms line output. Load the line output with 150 ohms and measure the voltage across the load; it should be at least 2.45V r.m.s. (40mW in 150 ohms).

4.9.2 Frequency response

Audio frequency response should be checked as follows:-

- (a) With the conditions as for 4.9.1 (c) adjust RV1 on module 9 for an audio output of 0.7V r.m.s. on the millivoltmeter.
- (b) Amplitude modulate the input signal to a depth of 30% at 1 kHz. Measure and note the audio output level to line.
- (c) Change the modulation frequency to 200 Hz and then to 3 kHz, noting the output level in each case; this should be not less than 4dB down on the level at 1 kHz.

4.9.3 Output adjustment

With conditions as in 4.9.2 (b) set RV1 on module 9 to give 0.775V r.m.s. on the millivoltmeter. Check that the front panel meter indicates to $1\text{mW} \pm 1/16\text{in.}$ when the meter switch is set to AF. (To test and adjust the meter circuits see 4.14.)

4.10 CALIBRATION

4.10.1 Interpolating oscillator

Check that the KILOHERTZ film scale can be calibrated as detailed in 2.3.2.

4.10.2 BFO

Zero beat on any convenient 100 kHz point as detailed in 4.10.1 above. With no input to the receiver, switch the MODE to CW and set the BFO knob to zero on the scale. If zero beat is not possible in this position adjust L1 on the BFO sub-unit to obtain it. (The unit side cover must be removed to gain access).

4.11 OSCILLATORS

If a fault is suspected in either the 1 MHz oscillator in module 10 or the interpolating oscillator, it can be verified by substituting the suspect oscillator with suitable external oscillators as detailed in 2.2.2. The activity of other oscillators should be verified as detailed in the following paragraphs.

4.11.1 First local oscillator (module 3)

Test the first local oscillator as follows:-

- (a) Set the INT. 1 MHz and INT. VFO links on the rear panel of the receiver to OFF. Unsolder the connections to pins 2 and 3 of module 3.
- (b) Break cable 8 and terminate the cable from module 3 with a 75 ohm resistive load. Connect a valve voltmeter across the load. The meter should indicate approximately 625mV r.m.s. Reconnect cable 8.

- (c) Repeat (b) at cable 9. A similar reading should be obtained.
- (d) With the load and meter still connected at cable 9, break cable 8 and measure, on a frequency counter, the frequency of the RF output at cable 8 termination. It should be not more than 37,000 MHz.
- (e) Set the internal oscillator links on the rear panel to ON. Reconnect pins 2 and 3 of module 3. Set the MEGAHERTZ control to indicate 1 MHz on the scale and verify, by use of the frequency counter, that the frequency at cable 8 is tunable by means of the receiver tuning over the range 38.2 to 39.4 MHz.
- (f) Set the MEGAHERTZ control to 29 MHz and verify that the output frequency is capable of being tuned over the range 66.2 to 67.4 MHz.

Failure to obtain satisfactory results in (b), (c) or (d) would indicate that module 3 is unserviceable, but failure in (e) or (f) may indicate a faulty module 3 or a fault in phase lock circuit testing as detailed in 4.12.

4.11.2 10.6/10.8 MHz oscillator (module 11)

To test the 10.6/10.8 MHz oscillator, proceed as follows:-

- (a) Break cable 15 (module 11 to module 5) and terminate the cable from module 11 with a 75 ohm resistive load. Connect a frequency counter across the load.
- (b) Select USB at the mode selector switch. The frequency as measured on the counter should be 10.800000 MHz.
- (c) Replace the counter with a valve voltmeter. The meter should indicate not less than 100mV r.m.s.
- (d) Select LSB or CW and repeat (b) and (c). The frequency should be 10.600 MHz and the meter indication, 100mV r.m.s.

4.11.3 Spectrum generator (module 10) and MHz selector

The 1 MHz oscillator in module 10 can best be eliminated as faulty by using an external 1 MHz oscillator (see 2.2.2.). However, if a suitable oscillator is not available, break cable 23 (module 10 to module 12) and measure the frequency on a counter at the cable from module 10; it should be 1.00000 MHz. C19 may be adjusted for this condition. Replace the counter with a 75 ohm resistive load and measure the output across the load; it should be not less than 400mV.

The 48 MHz output from module 10 can be measured across a 75 ohm resistive load connected across cable 12 from the module; an output of not less than 400mV at 48 MHz should be obtained.

Note: In making this test it may be found that the high 1 MHz content of the output may affect the operation of the frequency counter. It is therefore advisable to use a 75 ohm stepped attenuator as the resistive load and to set the attenuator to give minimum operative input to the counter.

Operation of the spectrum generator at all other frequencies can best be checked in conjunction with the MHz selector circuits in turret compartment 2 as detailed in 4.11.4.

4.11.4 Megacycle selector (turret compartment 2)

Verify correct operation of the megacycle selector circuit as follows:-

- (a) Remove the bottom cover of the turret. Locate the MHz input connection on board G in compartment 3 (fig.1) and connect it to the input of the frequency counter via a coaxial connector.
- (b) Switch on the PR155 and set the MEGAHERTZ control to 0. Verify that the frequency indicated is 35 MHz. (See Note in 4.11.3.).
- (c) Repeat (b) for each turret position, verifying that the output frequency increases by 1 MHz at each successive setting of the MEGAHERTZ control to 64 MHz at the 29 MHz setting.
- (d) Remove the frequency counter and connect a valve voltmeter in its place. The meter should indicate not less than 250mV r.m.s. at each setting of the MEGAHERTZ control.

4.12 PHASE LOCK CIRCUITS (TURRET COMPARTMENT 3)

Correct operation of the phase lock circuits should be verified as detailed below :-

- (a) Break cable 7, connecting the turret to the interpolating oscillator. Terminate the cable from the oscillator with a 75 ohm resistive load and connect a frequency counter across the load. Switch on the PR155 and adjust the KILOHERTZ tuning to obtain a frequency of 2.5 MHz on the counter. The control must remain in this position throughout the following tests. Switch off, remove the counter and load and reconnect cable 7.
- (b) Disconnect pin 2 of module 3 and reconnect to pin 2 via a 100k ohms resistor. Connect the D.C. input of an oscilloscope between pin 3 and earth. Break cable 9, connecting modules 2 and 3, terminate the cable from module 3 with a 75 ohm resistive load and connect the frequency counter across the load.
- (c) Connect oscilloscope between the reactor control lead on board J, turret compartment 3 and earth. (Fig.13 refers).

(d) Set receiver to 28 MHz. Adjust RV3 on board J to give the following waveform on the oscilloscope. (Diagram (a)).



Diagram (a)

(e) Reset MHz selector to 21 and 22 MHz in turn, adjusting RV1 on wafer E, turret compartment 2, (Fig. 10 refers) to place the locking response as near as possible to the centre of the sweep, i.e. compromise. (RV1 to 4 on wafer E are so positioned that only the one to be adjusted can be reached).

Reset MHz selector to 13 and 14 in turn, adjusting RV2 on wafer E for optimum.

(f) Reset MHz selector to 5 and 6 MHz in turn, adjusting RV3 on wafer E for optimum waveform ($t_1 = t_2$). (Diagram (b)).



Diagram (b)

(g) Reset MHz selector to 2 MHz and adjust RV4 on wafer E for optimum waveform. (Diagram (c)).

Lock RV1 to 4 on wafer E and RV3 on board 'J'.



Diagram (c)

(h) Reset receiver to 29 MHz and observe sweep waveform and ensure that it is symmetrical about the locking response. Set the receiver to each megacycle in turn down to 0, checking that the sweep waveform goes either side of the locking response by a satisfactory margin.

(j) Reconnect pin 2 on modules 3. Set the MEGAHERTZ control to 0; the oscilloscope trace should be a horizontal line and the frequency measured on the counter should be 37.500 MHz.

(k) Rotate the MEGAHERTZ control to each of its other positions in turn and at each position verify that the frequency is 1 MHz higher than at the previous position. If the local oscillator does not lock at a particular position, RV3 on board J may be slightly readjusted to make it lock. Should it be necessary to adjust RV3, verify that the oscillator locks satisfactorily at all positions previously tested. If satisfactory results are obtained, remove the test equipment and reconnect the coaxial cables.

4.13 ISOLATING AMPLIFIERS

With a signal at a frequency of 50 MHz and an e.m.f. of 1V applied at the input (cable 8) to the isolating amplifier, the voltage measured on a valve voltmeter connected across a 75 ohm load at the output connector (cable 9) should be not less than 0.5V r.m.s.

4.14 METER CIRCUITS

4.14.1 S '0' Adjustment

Set the MODE selector to USB, the BANDWIDTH to 3kHz and the RF/IF gain control to maximum. Switch the AGC to 0.1 secs and apply a signal of 15 MHz at 1 μ V e.m.f. to the 75 ohm AERIAL socket. Adjust RV3 on the meter circuit board to give a reading of S '0' on the front panel meter with S6 switched to RF.

4.14.2 S '9' Adjustment

With conditions as in 4.14.1 increase the signal level to 100 μ V and adjust RV2 to indicate S9 on the front panel meter. Reduce signal level to 1 μ V and recheck S '0' setting. If further adjustment is required repeat 4.14.1 and 4.14.2 until both conditions are satisfied. Lock RV2 and RV3.

5. COMPONENT INFORMATION

Note: When ordering spares it is advisable to quote the serial number of the receiver, module number and part number as quoted in this handbook. An operational spares kit is available (fuses, indicator lamp) under part number 630/LF/14375. A maintenance spares kit (resistors, capacitors, transistors etc.) is available under part number 630/LG/14375.

5.1 MAIN CHASSIS 630/1/14974/523

Resistors

R.No.	Value ohms	Tol. ± %	Rating Watts	Maker and Type	Part No.
11	330	10	$\frac{1}{4}$	Erie 16	403/4/78168/081
5	8.2M	10	$\frac{1}{4}$	Erie 16	403/4/78168/301
6	15	5	$\frac{1}{2}$	Erie 108	403/4/78183/247
10	390k	10	$\frac{1}{4}$	Erie 16	403/4/78168/233
14	120	10	$\frac{1}{4}$	Erie 16	403/4/78168/061
15	150	5	.1	Erie 15	403/4/78257/029

Capacitors

C.No.	Value uF	Tol. ± %	V.Wkg.	Maker and Type	Part No.
4	47		25	Plessey Electrolytic	402/4/01201/001
2	1700		50	Electrolytic	439/8/53808/032
5	500		25	Plessey Electrolytic	439/1/14441/011
7, 8	.01		1000	Dubilier 660M	400/4/98474/017
10	.1	20	250	Mullard C280	400/4/98268/007
11	1000p	20		Erie Ceramicon	400/4/98260/007

Miscellaneous

Circuit Ref.	Description	Part No.
RV1	Potentiometer, 1k ohm Lin.	404/1/02650/154
RV2	Potentiometer, 5k ohm ± 20% Log.	404/1/02650/296
VT1	Transistor, OC35 Mullard	417/4/98108/002
FLT1	Filter, Composite	422/8/00100/001
S1	Switch	408/1/00004/005
S2	Switch	408/1/00002/083
S4	Switch	408/8/00004/007
S5	Switch S.P.D.T.	408/4/98084/006
S6	Switch D.P.D.T.	408/4/98084/010
T1	Transformer	407/8/22047
T2	Transformer	407/4/98035

LS1	Loudspeaker	CP 130536/091501
FS1	Fuse Link, Size 00, L754, 1A (230V)	518/4/98000/006
FS1	Fuse Link, Size 00, L754, 2A (115V)	518/4/98000/007
FS2	Fuse Link, Size 00, L562, 2.5A	518/4/98004/007
	Box spanner 5242 Buck and Hickman	630/4/17437
PL1	Plug, electrical, fixed 3-pin, 5A, Mk.4	508/1/40061/320
JK1,JK2	Socket, jack, with black facia nut	511/4/98041/005
M1	Instrument, indicating	682/4/99011
L2 & L3	Choke	407/8/21965
L1	Choke	407/8/21959
ILP1	Lamp 14 volt 0.75 watt L.E.S.	517/4/98028
	Plug, elect. free, (BNC) Amphenol	508/4/28436
	Socket, elect. free, (BNC) Amphenol	508/4/28434
	Socket, elect. free, Mk.4	508/1/40001/320
	Belling Lee Min. Twin Socket Type L1391/S	508/4/28002
	Belling Lee Min. Free Plug L1465/FP/AG/N1	508/4/28041
	Belling Lee Min. Free Socket L1465/FS/AG/N1	508/4/28382
	Belling Lee Min. Fixed Socket L1465/CS/AG/N1	508/4/28075/001

5.2 INTERPOLATING OSCILLATOR (630/1/14000/001)

Resistors

R. No.	Value ohms	Tol. \pm %	Rating Watts	Maker and Type	Part No.
1	22k	10	$\frac{1}{4}$	Erie 16	403/4/78168/169
2	39k	10	$\frac{1}{4}$	Erie 16	403/4/78168/181
3,7,10	2.2k	10	$\frac{1}{4}$	Erie 16	403/4/78168/121
4	1k	10	$\frac{1}{4}$	Erie 16	403/4/78168/105
5	10k	10	$\frac{1}{4}$	Erie 16	403/4/78168/153
6	15k	10	$\frac{1}{4}$	Erie 16	403/4/78168/161
8	180	10	$\frac{1}{4}$	Erie 16	403/4/78168/069
9	5.6k	10	$\frac{1}{4}$	Erie 16	403/4/78168/141
11	470	10	$\frac{1}{4}$	Erie 16	403/4/78168/089
12,13,15	560	10	$\frac{1}{4}$	Erie 16	403/4/78168/093
14	4.7k	10	$\frac{1}{4}$	Erie 16	403/4/78168/137
16,17	56	10	$\frac{1}{4}$	Erie 16	403/4/78168/045
18	330	10	$\frac{1}{4}$	Erie 16	403/4/78168/081

Capacitors

C. No.	Value ohms	Tol. \pm %	V.Wkg.	Maker and Type	Part No.
1,9,14,15,) 16,19	.01	20	250	Mullard C280	400/4/98268/001
2,5,6,10	1000p	1		Mullard C295A	400/4/98245/001
3	3000p	1		Mullard C295A	400/4/98245/008
4	1000p	5	350	Mica, moulded	424/4/98070/004
7	0-6p			Trimmer	401/8/20006
8	33p	5		Erie N750/AD	400/4/98308/106
11	68p	5	125	Polystyrene	400/4/98179/019
12	220p	5	125	Polystyrene	400/4/98179/010
13	330p	5	125	Polystyrene	400/4/98179/015

Miscellaneous

Circuit Ref.	Description	Part No.
RV1	Potentiometer, 10k ohms	404/1/00405/009
L1	Coil Assembly	406/1/08379
L2	Trimmer Coil	406/8/08327
L3	RF Choke, miniature, 6.8 μ H \pm 10%	406/4/98012/002
L4, L5	RF Choke, miniature, 1000 μ H \pm 10%	406/4/98012/005
VT1 - VT4	Transistor, 2S512, Texas Insts.	417/4/98138
D1	Diode, Zener, 10V \pm 5%	415/4/98167/003
	Component Board Assembly	630/1/14404

5.3. B.F.O. ASSEMBLY (630/1/23304)

Resistors

R. No.	Value ohms	Tol. \pm %	Rating Watts	Maker and Type	Part No.
3	8.2k	10	$\frac{1}{4}$	Erie 16	403/4/78168/149
2	15k	10	$\frac{1}{4}$	Erie 16	403/4/78168/161
1	12k	10	$\frac{1}{4}$	Erie 16	403/4/78168/157
4	2.2k	10	$\frac{1}{4}$	Erie 16	403/4/78168/121
5, 7, 8	270	10	$\frac{1}{4}$	Erie 16	403/4/78168/077
6	18k	10	$\frac{1}{4}$	Erie 16	403/4/78168/165
9	12	10	$\frac{1}{4}$	Erie 16	403/4/78168/005

Capacitors

C. No.	Value μ F	Tol. \pm %	V. Wkg.	Maker and Type	Part No.
1	.047	20	250	Miniature foil	400/4/98268/005
2	3300p	1	125	Polystyrene	400/4/98245/010
3	1000p	1		Polystyrene	400/4/98245/001
4	470p	5	125	Polystyrene	400/4/98179/027
5,6,7	0.1	20	250	Miniature foil	400/4/98268/007
8	220p	5	125	Polystyrene	400/4/98366/018
9				Variable	401/4/98026/003

Miscellaneous

Circuit Ref.	Description	Part No.
RV1	Potentiometer, 5k oh.	404/1/00405/012
L1	Inductor Assembly	406/8/08323/005
L2	RF Choke, miniature, 1000 μ H \pm 10%	406/4/98012/005
VT1, VT2	Transistor BSY95A, ST95A, 2S512	417/4/98138
	Board Component	630/1/23306

5.4 REGULATOR ASSEMBLY (630/1/14608)

Refer to sub-section 5.18

5.5 TURRET ASSEMBLY (630/1/14300)

5.5.1 Compartment 1 Contact Board (630/1/14293)

Circuit Ref.	Description	Part No.
C1	Capacitor, 27 pF \pm 5% Type 310 N.P.O.	400/4/98322/049
L1	Choke, 0.22 μ H	406/8/08324/009

5.5.2 Filter Assembly (630/1/14289)

Circuit Ref.	Description	Part No.
FL1	Filter 0 - 2 MHz	630/1/14057
FL2	Filter 2 - 3 MHz	630/1/14058
FL3	Filter 3 - 4 MHz	630/1/14059
FL4	Filter 4 - 6 MHz	630/1/14060
FL5	Filter 6 - 9 MHz	630/1/14061
FL6	Filter 9 - 14 MHz	630/1/14062
FL7	Filter 14 - 21 MHz	630/1/14063
FL8	Filter 21 - 30 MHz	630/1/14064

5.5.3 Compartment 2 Contact Board (630/1/14292)

Resistors

R. No.	Value ohms	Tol. \pm %	Rating Watts	Maker and Type	Part No.
1	68	10	$\frac{1}{4}$	Erie 16	403/4/78168/019
2	1k	10	$\frac{1}{4}$	Erie 16	403/4/78168/105
3	1.8k	10	$\frac{1}{4}$	Erie 16	403/4/78168/117
4	39k	10	$\frac{1}{4}$	Erie 16	403/4/78168/181
5	470	10	$\frac{1}{4}$	Erie 16	403/4/78168/089
6	15k	10	$\frac{1}{4}$	Erie 16	403/4/78168/161
7	1.5k	10	$\frac{1}{4}$	Erie 16	403/4/78168/113
8	150	10	$\frac{1}{4}$	Erie 16	403/4/78168/065
9	47	10	$\frac{1}{4}$	Erie 16	403/4/78168/039
10	1.2k	10	$\frac{1}{4}$	Erie 16	403/4/78168/109
11	180	10	.1	Erie 15	403/4/78257/161

Capacitors

C. No.	Value μF	Tol. ± %	V. Wkg.	Maker and Type	Part No.
1	27p	5	250	Erie N750/AD	400/4/98308/104
2	8.2p	±0.5pf		Erie NPO/Ceramic	400/4/98425/054
3	47p	5		Polystyrene	400/4/98179/016
4	12p	5		Erie NPO/AD Ceramic	400/4/98425/089
5	10p	5		Erie NPO/AD Ceramic	400/4/98425/087
6	100p	5		Polystyrene	400/4/98179/026
7	0.1	20		Mullard C280	400/4/98268/007

Miscellaneous

Circuit Ref.	Description	Part No.
D1	Diode, IN4148	415/4/98393
D2	Diode, Zener, 1V ± 5%	415/4/98167/003
VT1, VT2, VT3	Transistor, 95A, 2S512, 3T95A	417/4/98138

5.5.4 Wafer Assembly (E) (630/1/11290)

Circuit Ref.	Description	Part No.
R4	Resistor, 120 ohms ± 10% 1/4W, Erie 16	403/4/78168/061
R1, 2, 3	Resistor, 150 ohms ± 10% 1/4W, Erie 16	403/4/78168/069
RV1	Potentiometer 1.5k ohms	403/1/00405/069
RV2, RV3, RV4	Potentiometer 1k ohm	403/1/00405/005

5.5.5 Wafer Assembly (F1) (F2) (630/1/14291)

Circuit Ref.	Description	Part No.
L1 : L31	Inductor Assembly 14 turns	406/8/08324/001
L2 : L32	Inductor Assembly 14 turns	406/8/08324/002
L3 : L33	Inductor Assembly 13 turns	406/8/08325/003
L4 : L34	Inductor Assembly 13 turns	406/8/08324/003
L5, L7 : L35, L37	Inductor Assembly 12 turns	406/8/08325/004
L6 : L36	Inductor Assembly 12 turns	406/8/08324/004
L8, L10, L12 : L38, L40, L42	Inductor Assembly 11 turns	406/8/08324/005
L9, L11, L13 : L39, L41, L43	Inductor Assembly 11 turns	406/8/08325/005
L14, L16 : L44, L46	Inductor Assembly 9 turns	406/8/08324/006
L15, L17 : L45, L47	Inductor Assembly 9 turns	406/8/08325/006
L18, L20, L22 : L48, L50, L52	Inductor Assembly 8 turns	406/8/08324/007
L19, L21, L23 : L49, L51, L53	Inductor Assembly 8 turns	406/8/08325/007
L24, L26, L28, L30 : L54, L56, L58, L60	Inductor Assembly 7 turns	406/8/08324/008
L25, L27, L29 : L55, L57, L59	Inductor Assembly 7 turns	406/8/08325/008

5.5.6 Compartment 3 Board G (630/1/14105)

Resistors

R. No.	Value ohms	Tol. \pm %	Rating Watts	Maker and Type	Part No.
1, 11, 16, 28	82	10	$\frac{1}{4}$	Erle 16	403/4/78168/053
2, 26	5.6k	10	$\frac{1}{4}$	Erle 16	403/4/78168/141
3, 9, 14,) 21, 27, 33)	10k	10	$\frac{1}{4}$	Erle 16	403/4/78168/153
4, 5, 6, 10,) 15, 18, 24, 25) 30)	470	10	$\frac{1}{4}$	Erle 16	403/4/78168/089
7, 12, 17, 34	1.2k	10	$\frac{1}{4}$	Erle 16	403/4/78168/109
8, 13, 20, 32	2.7k	10	$\frac{1}{4}$	Erle 16	403/4/78168/125
19, 22, 31, 39	47	10	$\frac{1}{4}$	Erle 16	403/4/78168/039
23	270	10	$\frac{1}{4}$	Erle 16	403/4/78168/077
29, 41	27	10	$\frac{1}{4}$	Erle 16	403/4/78168/023
35	4.7k	10	$\frac{1}{4}$	Erle 16	403/4/78168/137
36, 37, 38,) 42, 43)	560	10	$\frac{1}{4}$	Erle 16	403/4/78168/093
40	100	10	$\frac{1}{4}$	Erle 16	403/4/78168/057

Capacitors

C. No.	Value μ F	Tol. \pm %	V. Wkg.	Maker and Type	Part No.
1, 4, 6, 8, 17	.01	20	250	Mullard C280	400/4/98268/001
2	56p	5		Erle N750/AD	400/4/98308/112
3	100p	5		Erle N750/BD	400/4/98439/019
5, 7, 9	.047	20	250	Mullard C280	400/4/98268/005
10, 11, 12, 16) 18, 19, 20)	.001	-20+40		Ceramic H1-k	400/4/98260/016
13	1.5-18p			Variable	401/4/98023/004
14	27p	5		Erle N750/AD	400/4/98308/104
15	47p	5		Erle N750/AD	400/4/98308/110

Miscellaneous

Circuit Ref.	Description	Part No.
RV1	Potentiometer, 100 ohms	404/1/00405/001
L1	RF Choke, miniature 6.8 μ H \pm 10%	406/4/98012/002
L2	Ferrite Beads (3 off)	905/4/98052
T1 - T4	Transformer	406/8/08329/003
VT1-VT3, VT8	Transistor, 2S512, 5Y95A, 5Y95A	417/4/98138
VT4-VT6	Transistor, TI407, 2N3983	417/4/98135
D1 - D8	Diode, HG1012, Hughes International	415/4/98149

5.5.7 Compartment 3 Board H (630/1/14107)

Resistors

R. No.	Value ohms	Tol. ± %	Rating Watts	Maker and Type	Part No.
1,2,19,26	5.6k	10	$\frac{1}{4}$	Erie 16	403/4/78168/141
3,12,17)	560	10	$\frac{1}{4}$	Erie 16	403/4/78168/093
20,24)					
4, 5	270	10	$\frac{1}{4}$	Erie 16	403/4/78168/077
6, 7	27	10	$\frac{1}{4}$	Erie 16	403/4/78168/023
8, 10	1k	10	$\frac{1}{4}$	Erie 16	403/4/78168/105
11,14,22	220	10	$\frac{1}{4}$	Erie 16	403/4/78168/073
13,21,27	100	10	$\frac{1}{4}$	Erie 16	403/4/78168/057
15,23,9	47	10	$\frac{1}{4}$	Erie 16	403/4/78168/039
16, 29	10k	10	$\frac{1}{4}$	Erie 16	403/4/78168/153
18, 25	1.5k	10	$\frac{1}{4}$	Erie 16	403/4/78168/113
28	470	10	$\frac{1}{4}$	Erie 16	403/4/78168/089

Capacitors

C. No.	Value μF	Tol. ± %	V. Wkg.	Maker and Type	Part No.
1-4,6,8,21,) 9,10,12,13,) 14,16,17,20)	.001	20		Lemco Ceramic Hi-k	400/4/98260/007
7	.0047	-20+40		Lemco Ceramic Hi-k	400/4/98113/010
11	33p	5		Erie N750/AD	400/4/98308/106
18, 19	68p	5		Erie N750/AD	400/4/98308/114
22	12p	10		Erie NPO/AD	400/4/98308/096
31	560p	5	125	Lemco Polystyrene	400/4/98179/012
5	11	20	6	Kemet, K11N6 N5	402/4/98096/012

Miscellaneous

Circuit Ref.	Description	Part No.
L1	Inductor, 5 turns	406/8/08324/009
L2, L3	Ferroxcube beads (6 off)	905/4/98052
TR1, TR2, TR3	Transformer	406/8/08328
D1,D2,D3,D4,D7,D8	Diode, HG 1012, Hughes International	415/4/98149
D5, D6	Diode, IN4148	415/4/98393
VT1, VT5-VT8	Transistor, TI407, Texas Insts.	417/4/98135
VT2-VT4	Transistor, 2S512, Texas Insts.	417/4/98138

5.5.8 Compartment 3 Board J (630/1/14109)

Resistors

R. No.	Value ohms	Tol. ± %	Rating Watts	Maker and Type	Part No.
1,11	1.5k	5	$\frac{1}{4}$	Metal oxide	403/4/78148/079
4,5	8.2k	5	$\frac{1}{4}$	Metal oxide	403/4/78148/131
6	6.8k	10	$\frac{1}{4}$	Erie 16	403/4/78168/145
7	470	10	$\frac{1}{4}$	Erie 16	403/4/78168/089
8	2.2k	5	$\frac{1}{4}$	Metal oxide	403/4/78148/074
9	1k	10	$\frac{1}{4}$	Erie 16	403/1/78168/105
10,21,22	10k	10	$\frac{1}{4}$	Erie 16	403/4/78168/153
12,2,3	150	10	$\frac{1}{4}$	Erie 16	403/4/78168/065
13	330	10	$\frac{1}{4}$	Erie 16	403/4/78168/081
14	820	10	$\frac{1}{4}$	Erie 16	403/4/78168/101
16,18,19	4.7k	10	$\frac{1}{4}$	Erie 16	403/4/78168/137
17,20	47k	10	$\frac{1}{4}$	Erie 16	403/4/78168/185
15	220	10	$\frac{1}{4}$	Erie 16	403/4/78168/073

Capacitors

C. No.	Value uF	Tol. ± %	V. Wkg.	Maker and Type	Part No.
1	0.1	20	250	Mullard C280	400/4/98268/007
2,3	15	10	20	Plessey Electrolytic	402/1/50832/070
4	25		25	Plessey Electrolytic	402/1/01200/015
5	.047	20	250	Mullard C280	400/4/98268/005

Miscellaneous

Circuit Ref.	Description	Part No.
RV1	Potentiometer, 250 ohms	404/8/00405/008
RV2	Potentiometer, 5k ohms	404/8/00405/024
RV3	Potentiometer, 1.5k ohms	404/8/00405/069
RV4	Potentiometer, 25k	404/8/00405/023
D1	Diode, Zener, 10V ± 5%	415/4/98167/003
VT1-4, VT8, VT9	Transistor, 2S512, BSY95A, ST95A	417/4/98138
VT5, VT6	Transistor, 2S3030, Texas Insts.	417/4/98136
VT7	Transistor, 2N1507, Texas Insts.	417/4/98139

5.6 Module 1 - RF Amplifier (630/1/17670)

Resistors

R. No.	Value ohms	Tol. ± %	Rating Watts	Maker and Type	Part No.
1a,b,c,d	33	10	1	Erie 8	403/4/78229/154
2, 21	10	10	$\frac{1}{4}$	Erie 16	403/4/78168/001
3	39	10	$\frac{1}{4}$	Erie 16	403/4/78168/033
4, 11, 23	820	10	$\frac{1}{4}$	Erie 16	403/4/78168/101
6	6.8k	10	$\frac{1}{4}$	Erie 16	403/4/78168/145
5	2.2k	10	$\frac{1}{4}$	Erie 16	403/4/78168/121
7	2.7k	10	$\frac{1}{4}$	Erie 16	403/4/78168/125
9	1.5k	10	$\frac{1}{4}$	Erie 15	403/4/78257/172
16	1.5k	10	$\frac{1}{4}$	Erie 16	403/4/78168/113
10	470	10	$\frac{1}{4}$	Erie 16	403/4/78168/089
18	100	10	$\frac{1}{4}$	Erie 16	403/4/78168/059
13, 27	390	10	$\frac{1}{4}$	Erie 16	403/4/78168/085
14, 26	220	10	$\frac{1}{4}$	Erie 16	403/4/78168/073
15	180	10	$\frac{1}{4}$	Erie 16	403/4/78168/069
22	82	10	$\frac{1}{4}$	Erie 16	403/4/78168/053
17, 25	150	10	$\frac{1}{4}$	Erie 16	403/4/78168/065
24	270	10	$\frac{1}{4}$	Erie 16	403/4/78168/077
40	10k	10	$\frac{1}{4}$	Erie 16	403/4/78168/153
28	560	10	$\frac{1}{4}$	Erie 16	403/4/78168/093
36	56k	10	$\frac{1}{4}$	Erie 16	403/4/78168/191
35	1k	10	$\frac{1}{4}$	Erie 16	403/4/78168/105
37	22k	10	$\frac{1}{4}$	Erie 16	403/4/78168/169
44	820k	10	.1	Erie 15	403/4/78257/205
45	39	10	.1	Erie 15	403/4/78257/153

Capacitors

C. No.	Value- μF	Tol. ± %	V. Wkg.	Maker and Type	Part No.
1-14, 25	0.1	20	250	Mullard C280	400/4/98268/007
15	82pF	5		Lemco 1106-S	424/4/98042/129
18	12		25	Lemco SM	402/4/98009/032
16, 17	50		25	Lemco SM	402/4/98009/039
24	68	10	15	S.T.C. Tantalum	402/4/98022/027

Miscellaneous

Circuit Ref.	Description	Part No.
L1, L5, L6, L7	RF miniature choke 1000 μ H	406/4/98012/005
L2	RF miniature choke 150 μ H	406/4/98012/004
VT1	Transistor,	417/4/
VT2, VT3, VT4, VT6)	Transistor, BSY95A, 2S512, ST95A	417/4/98138
VT9	Transistor, BCY70, Texas Insts.	417/4/98267/001
VT5	Transistor, D986, Texas Insts.	417/4/98153
VT10	Diode, FRB126	415/4/98400
D1, D2, D4	Zener Diode 6.8V \pm 5%	415/4/98167/009
D5	Diode IN4148	415/4/98393
D6, D7	Board Component Unit 1	630/1/17671
D8	Diode OA95	415/4/98214
RV1	Potentiometer 500 Ω 20%	404/1/00405/002

5.7 Module 2 (630/1/14111)

Capacitors

C. No.	Value pF	Tol. \pm %	V.Wkg.	Maker and Type	Part No.
1	94	1pf	125	L.C.R.Ltd. Polystyrene	400/4/98263/026
2	11	1pf	125	L.C.R.Ltd. Polystyrene	400/4/98263/022
3	119	2%	125	L.C.R.Ltd. Polystyrene	400/4/98263/010
4	58	1pf	125	L.C.R.Ltd. Polystyrene	400/4/98263/024
5	103	2%	125	L.C.R.Ltd. Polystyrene	400/4/98263/016
6	40	1pf	125	L.C.R.Ltd. Polystyrene	400/4/98263/023
7	63	1pf	125	L.C.R.Ltd. Polystyrene	400/4/98263/025

Miscellaneous

Circuit Ref.	Description	Part No.
L1	Inductor, 9T	406/8/08324/006
L2, L3	Inductor, 8T	406/8/08324/007
T1, T2	Transformer	406/8/08329/002
FL1	Filter, 37.3MHz + bracket assy.	
D1, D2)	Diode, HP2900	415/4/98403
D3, D4)		
	Board, Component, Unit 2	630/1/14367
VT1	Transistor, T1S84	

5.8 Module 3 - 1st Local Oscillator (630/1/14112)

Resistors

R. No.	Value ohms	Tol. ± %	Rating Watts	Maker and Type	Part No.
3	68k	10	$\frac{1}{4}$	Erie 16	403/4/78168/195
4	820	10	$\frac{1}{4}$	Erie 16	403/4/78168/101
5	1.8k	10	$\frac{1}{4}$	Erie 16	403/4/78168/117
6	1.5k	10	$\frac{1}{4}$	Erie 16	403/4/78168/113
7, 15	270	10	$\frac{1}{4}$	Erie 16	403/4/78168/077
9, 10	5.6k	10	$\frac{1}{4}$	Erie 16	403/4/78168/141
11	560	10	$\frac{1}{4}$	Erie 16	403/4/78168/093
12	330	10	$\frac{1}{4}$	Erie 16	403/4/78168/081
14	100	10	$\frac{1}{4}$	Erie 16	403/4/78168/057
18, 19	47	10	$\frac{1}{4}$	Erie 16	403/4/78168/039
13, 16	56	10	$\frac{1}{4}$	Erie 16	403/4/78168/045

Capacitors

Circuit Ref.	Value μF	Tol. ± %	V. Wkg.	Maker and Type	Part No.
C1, C2, C4,) C6, C7, C8,) C9	.001	20	125	Lemco Ceramic Hi-k	400/4/98260/007
C3	56p	5	300	Ceramic	400/4/98308/112
C5	0.8-12p			Trimmer, tubular ceramic	401/4/98023/003

Miscellaneous

Circuit Ref.	Description	Part No.
Z1	Saturable reactor	407/1/21963/001
VT1, VT2	Transistor, TI407, 2N3983	417/4/98135
VT3, VT4	Transistor, 2S512, BSY95A, ST95A	417/4/98138
D1, D2	Diode, BA110, STC	415/4/98148
D3	Diode, IN4148	415/4/98393
F1, F2, F3, F4	UHF min. feed-thro' Ceramicon Erie CFT 3000 Board Component	400/4/98266 630/1/14443

5.9 MODULE 4 (630/1/14117)

5.9.1 Unit 4A (630/1/14093)

Resistors

R. No.	Value ohms	Tol. ± %	Rating Watts	Maker and Type	Part No.
1	180	10	$\frac{1}{4}$	Erie 16	403/4/78168/069
2, 4	100	10	$\frac{1}{4}$	Erie 16	403/4/78168/057
3, 16	75	5	1	Erie 16	403/4/78257/052
5	47k	10	$\frac{1}{4}$	Erie 16	403/4/78168/185
6, 14, 19, 24	10k	10	$\frac{1}{4}$	Erie 16	403/4/78168/153
8	470	10	$\frac{1}{4}$	Erie 16	403/4/78168/089
13	22k	10	$\frac{1}{4}$	Erie 16	403/4/78168/169
15	1k	10	$\frac{1}{4}$	Erie 16	403/4/78168/105
18, 20, 21, 22	4.7k	10	$\frac{1}{4}$	Erie 16	403/4/78168/137
17	390	10	$\frac{1}{4}$	Erie 16	403/4/78168/085
23	3.3k	10	$\frac{1}{4}$	Erie 16	403/4/78168/129
25	18	10	$\frac{1}{4}$	Erie 16	403/4/78168/013
26	27	10	$\frac{1}{4}$	Erie 16	403/4/78168/023
28	82	10	$\frac{1}{4}$	Erie 16	403/4/78168/053

Capacitors

C. No.	Value μ F	Tol. ± %	V. Wkg.	Maker and Type	Part No.
1-9, 12, 13, 19-24)	.01	20%	250	Mullard C280 Film	400/4/98268/001
14	59p	1pf	125	Polystyrene	400/4/98263/005
15	24p	2%	125	Polystyrene	400/4/98263/027
16	80p	2%	125	Polystyrene	400/4/98263/023
17	88p	2%	125	Polystyrene	400/4/98263/029
18	27p	1pf	125	Polystyrene	400/4/98263/002
25	27p	5%	125	Ceramic	400/4/98308/104
35, 36	3.3p	± 0.5pf		Ceramic NPO DD	400/4/98425/106

Miscellaneous

Circuit Ref.	Description	Part No.
RV1	Potentiometer 1k ohms	404/1/00405/005
L1, L2, L5	Miniature RF Choke 6.8 μ H ± 10%	406/4/98012/002
L3	Inductor 7T	406/8/08324/008
L4	Inductor 4T	406/8/08324/010
F1, F2, F3, F4	UHF min. feed thro' Ceramicon, Erie CTF 3000	400/4/98266
JT1	Transistor, GM378 Texas In. s.	417/4/98137
VT2	Transistor, TI407 2N3983	417/4/98135
VT3, VT4	Transistor, 2S512, 6SY95A, 6T95A	417/4/98138
D1	Diode IN4148	417/4/98323

5.9.2. UNIT 4B (630/1/14095)

Resistors

R. No.	Value ohms	Tol. ± %	Rating Watts	Maker and Type	Part No.
29	1k	10	$\frac{1}{4}$	Erie 16	403/4/78168/105
30	150	10	$\frac{1}{4}$	Erie 16	403/4/78168/065
31	10k	10	$\frac{1}{4}$	Erie 16	403/4/78168/153
32	470	10	$\frac{1}{4}$	Erie 16	403/4/78168/089
33	1.5k	10	$\frac{1}{4}$	Erie 16	403/4/78168/113
34	47	10	$\frac{1}{4}$	Erie 16	403/4/78168/039
35	270	10	$\frac{1}{4}$	Erie 16	403/4/78168/077
36, 37	180	10	0.1	Erie 15	403/4/78257/161

Capacitors

C. No.	Value μ F	Tol. %	V. Wkg.	Maker and Type	Part No.
26	27p	± 5	125	Ceramic	400/4/98038/104
27, 34	18p	± 5		Erie N750/AD	400/4/98308/100
32	3.3p	±0.5pF		Ceramic	400/4/98425/044
33	10p	±0.5pF		Ceramic	400/4/98425/087
30, 31	.01 μ F	+20%		Mullard C286	400/4/98268/001
29, 28	4.7p	±.5pF		Ceramic	400/4/98425/079

Miscellaneous

Circuit Ref.	Description	Part No.
L6	Inductor, 9T	406/8/08324/006
F1, F2	UHF min.feed thro' Ceramicon Erie CFT 3000	400/4/98266
FL1	Crystal Filter 10.7 MHz	428/4/98065
VT5, VT6, VT7	Transistor 2S512	417/4/98016

5.10 Module 5 (630/1/17760)

Resistors

R. No.	Value ohms	Tol. ± %	Rating Watts	Maker and Type	Part No.
1	82	10	$\frac{1}{4}$	Erie 16	403/4/78168/053
2, 5	470	10	$\frac{1}{4}$	Erie 16	403/4/78168/089
3	15k	10	$\frac{1}{4}$	Erie 16	403/4/78168/161
4, 15, 18) 24, 26)	10k	10	$\frac{1}{4}$	Erie 16	403/4/78168/153
6, 30	1k	10	$\frac{1}{4}$	Erie 16	403/4/78168/105
7, 14, 17, 19) 22, 23, 25)	4.7k	10	$\frac{1}{4}$	Erie 16	403/4/78168/137

16, 27	560	10	$\frac{1}{4}$	Erie 16	403/4/78168/093
21	1.5k	10	$\frac{1}{4}$	Erie 16	403/4/78168/113
28	68	10	$\frac{1}{4}$	Erie 16	403/4/78168/049
29	100	10	$\frac{1}{4}$	Erie 16	403/4/78168/057

Capacitors

C. No.	Value μ F	Tol. \pm %	V. Wkg.	Maker and Type	Part No.
1 to 7	.022	20	30	Erie NPO/911	400/4/98268/003
12, 13, 14,) 15, 16, 18,) 19, 20)	0.1	20	30	Erie NPO/911	400/4/98268/007
17	220p	5	125	Polystyrene	400/4/98179/010
21	.001	20		Ceramicon	400/4/98260/007

Miscellaneous

Circuit Ref.	Description	Part No.
VT1	Transistor GM378 Texas Insts.	417/4/98137
VT3, VT4, VT5,) VT6)	Transistor 2S512, BSY95A, ST95A	417/4/98138
D1, D2	Diode IN4148	415/4/98393
F1, F2, F3, F4	UHF min. feed thro' Ceramicon Erie CFT3000	400/4/98266
L1	Board, Component, Unit 5 RF Choke 1000mH	630/1/17761 406/4/98012/005

5.11 Module 7 (630/1/17775)

5.11.1 Unit 7A (630/1/17771)

Resistors

R. No.	Value ohms	Tol. \pm %	Rating Watts	Maker and Type	Part No.
1	75	5	$\frac{1}{4}$	Erie 16	403/4/78184/052
9, 14, 29	1k	10	$\frac{1}{4}$	Erie 16	403/4/78168/105
3	27k	10	$\frac{1}{4}$	Erie 16	403/4/78168/173
4	100k	10	$\frac{1}{4}$	Erie 16	403/4/78168/203
5, 10, 24	470	10	$\frac{1}{4}$	Erie 16	403/4/78168/089
6	4.7k	10	$\frac{1}{4}$	Erie 16	403/4/78168/137
7, 19, 2	1.5k	10	$\frac{1}{4}$	Erie 16	403/4/78168/113
11, 16, 23	100	10	$\frac{1}{4}$	Erie 16	403/4/78168/057

12, 17	10k	10	$\frac{1}{4}$	Erie 16	403/4/78168/153
13	68k	10	$\frac{1}{4}$	Erie 16	403/4/78168/195
15, 25	3.9k	10	$\frac{1}{4}$	Erie 16	403/4/78168/133
18	47k	10	$\frac{1}{4}$	Erie 16	403/4/78168/185
20	33	10	$\frac{1}{4}$	Erie 16	403/4/78168/029
21	680	10	$\frac{1}{4}$	Erie 16	403/4/78168/097
26	180	10	$\frac{1}{4}$	Erie 16	403/4/78168/069
27	1.5k	10	0.1	Erie 15	403/4/78257/172
28	560	10	$\frac{1}{4}$	Erie 16	403/4/78168/093
46	220	10	$\frac{1}{4}$	Erie 16	403/4/78168/073
47	330	10	$\frac{1}{4}$	Erie 16	403/4/78168/081
48	39	10	$\frac{1}{4}$	Erie 16	403/4/78168/033
22	180	10	.1	Erie 15	403/4/78257/161

Capacitors

C. No.	Value μF	Tol. $\pm \%$	V. Wkg.	Maker and Type	Part No.
1, 2, 5, 8, 9) 13, 14, 39)	.047	20	250	Mullard C280	400/4/98268/005
4, 6, 7, 11, 15) 16, 20, 35, 36) 37, 38)	0.1	20	250	Mullard C280	400/4/98268/007
10	.005	1	150	Mullard C295A	400/4/98245/006
12, 40	2	Plessey Electrolytic		439/1/10171/091	
18	.002	1	20	Mullard C295A	400/4/98245/003
19	47	Electrolytic		402/8/50833/029	

Miscellaneous

Circuit Ref.	Description	Part No.
RV1	Potentiometer 10k ohms $\pm 20\%$	404/1/00405/009
L1, L2, L3, L4	RF Choke, miniature 1000 μH $\pm 10\%$	406/4/98012/005
VT1-VT5, VT10	Transistor, 2S512, BSY95A, ST95A	417/4/98138
D1, D2	Diode, IN4148	415/4/98393
D3	Zener diode 4.7v $\pm 5\%$	415/4/98167/001

5.11.2 Unit 7B (630/1/17774)

Resistors

R. No.	Value ohms	Tol. \pm %	Rating Watts	Maker and Type	Part No.
30	1.8k	10	$\frac{1}{4}$	Erie 16	403/4/78168/117
31, 35	10k	10	$\frac{1}{4}$	Erie 16	403/4/78168/153
32,33,43,42	1k	10	$\frac{1}{4}$	Erie 16	403/4/78168/105
34	2.7k	10	$\frac{1}{4}$	Erie 16	403/4/78168/125
36, 51	220	10	$\frac{1}{4}$	Erie 16	403/4/78168/073
37	470	10	$\frac{1}{4}$	Erie 16	403/4/78168/089
38	39k	10	$\frac{1}{4}$	Erie 16	403/4/78168/181
39, 44	15k	10	$\frac{1}{4}$	Erie 16	403/4/78168/161
40	4.7k	10	$\frac{1}{4}$	Erie 16	403/4/78168/137
41	33k	10	$\frac{1}{4}$	Erie 16	403/4/78168/177
49	3.3k	10	$\frac{1}{4}$	Erie 16	403/4/78168/129
50	1.5k	10	$\frac{1}{4}$	Erie 16	403/4/78168/113
52	6.8k	10	$\frac{1}{4}$	Erie 16	403/4/78168/145
53, 54	180	10	$\frac{1}{4}$	Erie 15	403/4/78257/161

Capacitors

C. No.	Value μ F	Tol. \pm %	V. Wkg.	Maker and Type	Part No.
17	.0024	1		Mullard C295A	400/4/98245/004
21	25	-10+50	25	Mullard C426	402/4/98031/034
22,23,31	50	-10+50	25	Mullard C426	402/1/98031/035
24,25,26,32	0.1	20	250	Mullard C280	400/4/98268/007
27	.002	1		Mullard C295A	400/4/98245/003
28	.0047	-20+40	500	Erie 811/K350081	400/4/98113/010
30, 34	6.4	-10+50	25	Mullard C426	402/4/98031/032
33	47	20	20	Electrolytic	402/8/50833/029

Miscellaneous

Circuit Ref.	Description	Part No.
VT6 - VT11	Transistor, BSY95A, 2S512, ST95A	417/4/98138
D4	Diode, IN4148	415/4/98393
L5, L6	RF Choke, Miniature 1000 μ H	406/4/98012/005
T1	Transformer (14MM)	406/8/08326/002
T2	Transformer (26MM)	406/8/08220/009

Resistors

R. No.	Value ohms	Tol. ± %	Rating Watts	Maker and Type	Part No.
1	2.2k	10	$\frac{1}{4}$	Erie 16	403/4/78168/121
2	2.7k	10	$\frac{1}{4}$	Erie 16	403/4/78168/125
3, 11, 15	10k	10	$\frac{1}{4}$	Erie 16	403/4/78168/153
4, 5, 17	560	10	$\frac{1}{4}$	Erie 16	403/4/78168/093
6	3.9k	10	$\frac{1}{4}$	Erie 16	403/4/78168/133
7, 13	4.7k	10	$\frac{1}{4}$	Erie 16	403/4/78168/137
12	27k	10	$\frac{1}{4}$	Erie 16	403/4/78168/173
14	6.8k	10	$\frac{1}{4}$	Erie 16	403/4/78168/145
16	82k	10	$\frac{1}{4}$	Erie 16	403/4/78168/199
8	150	10	$\frac{1}{4}$	Erie 16	403/4/78168/065
10	470	10	$\frac{1}{4}$	Erie 16	403/4/78168/089
9	15k	10	$\frac{1}{4}$	Erie 16	403/4/78168/161

Capacitors

C. No.	Value μ F	Tol. ± %	V. Wkg.	Maker and Type	Part No.
1, 2, 3, 7, 9	0.1	20	250	Mullard C280	400/4/98268/007
4	.0022	1	125	Mullard C295A	400/4/98245/009
8	68	10	15	S.T.C. Tant. Electrolytic	402/4/98022/027
10, 11	47		20	Electrolytic	402/8/50833/029
12	2.2	60		Plessey Electrolytic	439/1/02106/451
5	.47	10	160	Wima Tropyfol M	640/8/08705/003
6	12		25	Plessey Electrolytic	402/1/01375/001
13	6.4	+50-10	25	Mullard C426-AR-F	402/4/98031/032

Miscellaneous

Circuit Ref.	Description	Part No.
T1	Transformer	406/8/08225/012
L1, L2, L3, L4	RF Choke, miniature, 1000 μ H \pm 10%	406/4/98012/005
VT1, VT2	Transistor 2S512, BSY95A, ST95A	417/4/98138
VT3	Transistor 2S3030 Texas Insts.	417/4/98136
VT4-VT9	Transistor BCY70	417/4/98267/001
RV1	Potentiometer, 10k ohms	404/1/00405/009
RV2	Potentiometer, 2.5k ohms	404/1/00405/004
D1, D3, D4, D5, D6, D8, D9	Diode, IN4148	415/4/98393
D2	Diode Zener 8.2	415/4/98167/006
D7	Diode Zener 3.3v	415/4/98167/007

5.13 Module 9 (630/1/14119)

5.13.1 Unit 9A (630/1/14188)

Resistors

R. No.	Value ohms	Tol. ± %	Rating Watts	Maker and Type	Part No.
1	1.8k	10	$\frac{1}{4}$	Erie 16	403/4/78168/117
2	5.6k	10	$\frac{1}{4}$	Erie 16	403/4/78168/141
3	100	10	$\frac{1}{4}$	Erie 16	403/4/78168/057
4, 6	220	10	$\frac{1}{4}$	Erie 16	403/4/78168/073
5	12k	10	$\frac{1}{4}$	Erie 16	403/4/78168/157
7	2.2k	10	$\frac{1}{4}$	Erie 16	403/4/78168/121
8	330	10	$\frac{1}{4}$	Erie 16	403/4/78168/081
9, 10, 11	10	10	$\frac{1}{4}$	Erie 16	403/4/78168/001

Capacitors

C. No.	Value μF	Tol. ± %	V. Wkg.	Maker and Type	Part No.
1	1		25	Electrolytic	402/1/98009/024
2, 4, 5	47		25	Electrolytic	402/1/01201/001
3	560p	5	125	Polystyrene	400/4/98179/012
6	250		25	Electrolytic	402/1/01297/001
7	25		25	Electrolytic	402/1/01200/015
8, 9	0.1	20	250	Mullard C280	400/4/98268/007
10	220p	10		Synthetic Resin	424/4/98042/192

Miscellaneous

Circuit Ref.	Description	Part No.
VT1, VT3	Transistor, 2S512, BSY95A, ST95A	417/4/98138
VT2	Transistor, ASY26 S.T.C.	417/4/98039/001
VT4, VT5	Transistor, 2N1507 Texas Insts.	417/4/98139
D1, D2	Diode, OA200 Mullard	415/4/98011
RV1	Potentiometer, 100k ohms	404/1/00405/006
RV2	Potentiometer, 1k ohms	404/1/00405/005

5.13.2 Unit 9B (630/1/14084)

Resistors

R.No.	Value ohms	Tol. \pm %	Rating Watts	Maker and Type	Part No.
1	1.2k	10	$\frac{1}{4}$	Erie 16	403/4/78168/109
6	2.2k	10	$\frac{1}{4}$	Erie 16	403/4/78168/121
2,10	1k	10	$\frac{1}{4}$	Erie 16	403/4/78168/105
3	10k	10	$\frac{1}{4}$	Erie 16	403/4/78168/153
4,8	470	10	$\frac{1}{4}$	Erie 16	403/4/78168/089
5	82	10	$\frac{1}{4}$	Erie 16	403/4/78168/053
7	15k	10	$\frac{1}{4}$	Erie 16	403/4/78168/161
9	2.7k	10	$\frac{1}{4}$	Erie 16	403/4/78168/125
11	33k	10	$\frac{1}{4}$	Erie 16	403/4/78168/177
12	27k	10	$\frac{1}{4}$	Erie 16	403/4/78168/173
13	22	10	$\frac{1}{4}$	Erie 16	403/4/78168/017
14	4.7k	10	$\frac{1}{4}$	Erie 16	403/4/78168/137

Capacitors

C.No.	Value ohms	Tol. \pm %	V.Wkg.	Maker and Type	Part No.
1,6,7	2		70	Plessey Electrolytic	402/1/01223/001
2,8	47		20	Electrolytic	402/8/50833/029
3	.0033	-20+40	500	Lemco Ceramic, Hi-k	400/4/98113/006
4	.0047	-20+40	500	Lemco Ceramic, Hi-k	400/4/98113/010
5	25		25	Plessey Electrolytic	402/1/01200/015

Miscellaneous

Circuit ref.	Description	Part No.
RV1	Potentiometer 5k ohms	404/1/00405/024
RV2	Potentiometer 100k ohms	404/1/00405/006
VT1 to VT4	Transistor 2S512, BSY95A, ST95A	417/4/98138

5.14 MODULE 10 MKII - SPECTRUM GENERATOR (630/1/14930)

5.14.1 Board 'A' (MK.II) (630/1/14931)

Resistors

R.No.	Value ohms	Tol. ± %	Rating Watts	Maker and Type	Part No.
8	2.2k	10	$\frac{1}{4}$	Fixed Composition	403/4/78168/121
9,12	8.2k	10	$\frac{1}{4}$	Fixed Composition	403/4/78168/149
10	1.5k	10	$\frac{1}{4}$	Fixed Composition	403/4/78168/113
11,19	1k	10	$\frac{1}{4}$	Fixed Composition	403/4/78168/105
13,15	1.8k	10	$\frac{1}{4}$	Fixed Composition	403/4/78168/117
14	100	10	$\frac{1}{4}$	Fixed Composition	403/4/78168/057
17	120	10	$\frac{1}{4}$	Fixed Composition	403/4/78168/061
18,22,26	470	10	$\frac{1}{4}$	Fixed Composition	403/4/78168/089
20	680	10	$\frac{1}{4}$	Fixed Composition	403/4/78168/097
27	220k	10	$\frac{1}{4}$	Fixed Composition	403/4/78168/073
28	3.3k	10	$\frac{1}{4}$	Fixed Composition	403/4/78168/129
29	180	10	$\frac{1}{4}$	Fixed Composition	403/4/78168/069
30,33	560	10	$\frac{1}{4}$	Fixed Composition	403/4/78168/093
31	150k	10	$\frac{1}{4}$	Fixed Composition	403/4/78168/211
32	68k	10	$\frac{1}{4}$	Fixed Composition	403/4/78168/195
34	150	10	$\frac{1}{4}$	Fixed Composition	403/4/78168/065
35	1k	10	$\frac{1}{4}$	Erie Type 15	403/4/78257/170
37	47	10	$\frac{1}{4}$	Erie Type 15	403/4/78168/039
38-42	180	10	$\frac{1}{4}$	Erie Type 15	403/4/78168/161
43	47	10	$\frac{1}{4}$	Erie Type 15	403/4/78168/154

Capacitors

C.No.	Value ohms	Tol. ± %	V.Wkg.	Maker and Type	Part No.
5,7,8,10)	0.1	20	250	Miniature Foil	400/4/98268/007
11,12,13)	0.1	20	250	Miniature Foil	400/4/98 68/007
14,26,28)					
9,16,17	82p	5	125	Polystyrene	400/4/98179/011
20,30	68p	5		Ceramic	400/4/98038/114
21	33p	5		Ceramic	400/4/98038/106
23	10p	10		Erie Type NPO/AD	400/4/98425/118
24,25	220p	5	125	Polystyrene	400/4/98179/010
27	4-40p			Plastic Dielectric Trimmer	401/4/98083
29	1000p		125	Polystyrene Fixed	400/4/98425/001
15	10p	5			400/4/98425/087

Miscellaneous

Circuit Ref.	Description	Part No.
L1, L3	RF Choke, miniature .22uH	406/4/98012/006
L2	RF Choke, miniature 4.7uH	406/4/98012/001
VT3-4,)	Transistor	417/4/03007/016
VT6-9)		or 417/4/98138
VT5	Transistor, TI407	417/4/98135
D1	Diode, IN148	415/4/98393
XL1	Crystal 1 MHz	428/4/98034

5.14.2 Board B (630/1/14271)

Resistors

R.No.	Value ohms	Tol. ± %	Rating Watts	Maker and Type	Part No.
1	100	10	$\frac{1}{4}$	Erie 16	403/4/78168/057
2	1k	10	$\frac{1}{4}$	Erie 16	403/4/78168/105
3	1.8k	10	$\frac{1}{4}$	Erie 16	403/4/78168/117
4	39k	10	$\frac{1}{4}$	Erie 16	403/4/78168/181
5	470	10	$\frac{1}{4}$	Erie 16	403/4/78168/089
6	15k	10	$\frac{1}{4}$	Erie 16	403/4/78168/161
7	1.5k	10	$\frac{1}{4}$	Erie 16	403/4/78168/113
8	150	10	$\frac{1}{4}$	Erie 16	403/4/78168/065
9	47	10	$\frac{1}{4}$	Erie 16	403/4/78168/039
10,11	180	10	$\frac{1}{4}$	Erie 15	403/4/78257/161
12	27	5	$\frac{1}{4}$	Erie 15	403/4/78257/011

Capacitors

C.No.	Value uF	Tol. ± %	V.Wkg.	Maker and Type	Part No.
1	27p	5		Ceramic	400/4/98322/049
2	8.2p	+0.5p		Ceramic	400/4/98425/085
3	47p	5	125	Polystyrene	400/4/98179/016
4	12p	5		Ceramic	400/4/98425/089
5	10p	.5p		Ceramic	400/4/98425/087
6,10	.01	20	250	Mullard C280	400/4/98268/001
7,14	0.1	20	250	Mullard C280	400/4/98268/007
12,13	.001	-20+40		Ceramic	402/4/98260/016
8	50		25	Lemco SM	400/4/98009/039
15	18p	5		Ceramic	400/4/98308/100

Miscellaneous

Circuit Ref.	Description	Part No.
L1, L2	Inductor	406/4/08324/005
L4	Miniature Choke 1000uH	406/6/98012/005
L6	Miniature Choke 100 uH	406/4/98012/003
L8, L9	Ferroxcube beads (6 off)	905/4/98052
D1	Diode IN4148	415/4/98393
D2	Diode Zener, 10V +5%	415/4/98167/003
VT1,VT2,VT3	Transistor, 2S512, Texas Insts., BSY95A, ST95A.	417/4/98138

5.15 MODULE 11 MKII - 10.6/10.8 MHz GENERATOR (630/1/14938)

Resistors

R. No.	Value ohms	Tol. ± %	Rating Watts	Maker and Type	Part No.
1	1k	10	$\frac{1}{4}$	Fixed Composition	403/4/78168/105
2	68k	10	$\frac{1}{4}$	Fixed Composition	403/4/78168/049
3	1.8k	10	$\frac{1}{4}$	Fixed Composition	403/4/78168/117
4	39k	10	$\frac{1}{4}$	Fixed Composition	403/4/78168/181
5, 31	470	10	$\frac{1}{4}$	Fixed Composition	403/4/78168/089
6	220k	10	$\frac{1}{4}$	Fixed Composition	403/4/78168/219
7	15k	10	$\frac{1}{4}$	Fixed Composition	403/4/78168/161
8	1.5k	10	$\frac{1}{4}$	Fixed Composition	403/4/78168/113
9	220	10	$\frac{1}{4}$	Fixed Composition	403/4/78168/073
11,15,18,21) 24 }	1.8k	2	$\frac{1}{4}$	Fixed Composition	403/4/78159/034
12,14,17,) 20,23 }	330	2	$\frac{1}{4}$	Fixed Composition	403/4/78159/032
13,16,19,) 22,25 }	180	2	$\frac{1}{4}$	Fixed Composition	403/4/78159/030
26	100	10	$\frac{1}{4}$	Fixed Composition	403/4/78168/057
27,10	6.8k	10	$\frac{1}{4}$	Fixed Composition	403/4/78168/145
28	18k	10	$\frac{1}{4}$	Fixed Composition	403/4/78168/165
29	680	10	$\frac{1}{4}$	Fixed Composition	403/4/78168/097
32	82	10	$\frac{1}{4}$	Fixed Composition	403/4/78168/053
33	4.7k	10	1	Fixed Composition	403/4/78257/178
34	1.2k	10	$\frac{1}{4}$	Fixed Composition	403/4/78168/109

Capacitors

C.No.	Value uF	Tol. ± %	V.Wkg.	Maker and Type	Part No.
1	27p	5		Ceramic NPO/AD	400/4/98314/105
2,16	8.2p	55		Ceramic NPO/AD	400/4/98047/006
3	47p	5	125	Polystyrene	400/4/98179/016
4	12p	5		Ceramic N560/AD	400/4/98394/033
5	33p	5		Ceramic N750/AD	400/4/98308/106
6,12	12p	5		Ceramic NPO/AD	400/4/98047/007
7,11	0.1	20	250	Miniature Foil	400/4/98268/007
8,9,13,14	0.047	20	250	Miniature Foil	400/4/98268/005
10	0.01		25	Ceramic 831T	400/4/98190/052
15	330p	5	125	Polystyrene	400/4/98179/015
17	39p	1	125	Polystyrene	400/4/98212/023

Miscellaneous

Circuit Ref.	Description	Part No.
RV1	Potentiometer, Mini Flat Pot, Painton 25K	404/4/98118/001
RV2	Potentiometer, Type G, MK2A 500ohms	404/1/00405/002
D1	Diode, IN4148	415/4/98393
D2	Diode, Zener, 10V	415/4/98167/003
D3 - 7	Diode, Zener, 2.7V	415/4/98167/005
D8	Diode, BA110	415/4/98148
D9	Diode, Zener, 6.8V	415/4/98167/009
VT1-14	Transistor, BSY95A Selected	417/4/98530
L1,L2	Inductor Assy. 7 turns	406/4/08324/008
L3	Inductor Assy. 11 turns	406/4/08324/005
L4,5,6	Choke, RF Miniature 100uH	406/4/98012/003
L7	Inductor Assy.	406/1/08459

Module 12 (630/1/26390/001)

Resistors

R.No.	Value ohms	Tol. %	Rating Watts	Maker and Type	Part No.
1,21	82	10	.1	Erie 15	403/4/78257/157
2,17	1.5k	10	.1	Erie 15	403/4/78257/172
3	8.2	10	.1	Erie 15	403/4/78257/181
4,9	180	10	.1	Erie 15	403/4/78257/161
5	47	10	.1	Erie 15	403/4/78257/154
6	2.2k	10	.1	Erie 15	403/4/78257/174
7,15,18	4.7k	10	.1	Erie 15	403/4/78257/178
8	3.3k	10	.1	Erie 15	403/4/78257/176
10	220	10	.1	Erie 15	403/4/78257/162
11	100	10	.1	Erie 15	403/4/78257/158
12,19	150	10	.1	Erie 15	403/4/78257/160
13,14	270	10	.1	Erie 15	403/4/78257/163
16,20	10k	10	.1	Erie 15	403/4/78257/182
22	390	10	.1	Erie 15	403/4/78257/165
23	120	10	1	Fixed Composition	403/4/78229/161
24	22	10	.1	Erie 15	403/4/78257/150

Capacitors

C.No.	Value uF	Tol. %	V.Wkg.	Maker and Type	Part No.
1,2,3,4, 8,9,10, 11,13,15)	0.1	20	250	Miniature Foil	400/4/98268/007
5,14	50	-10+100	25	Miniature aluminium	402/4/98009/039
6	0.0068	10	30	Polystyrene	400/4/98719/001
7	0.01	20	250	Polystyrene	400/4/98268/001
12	82p	5	125	Polystyrene	400/4/98179/011

Miscellaneous

Circuit Ref.	Description	Part No.
L1,L2,L3	Choke 100uH	406/4/98012/003
D1	Diode Zener 4.7V	415/4/98167/001
D2,D4	Diode IN4148	415/4/98393
VT1-VT3	Transistor BSY95A,2S512,ST95A	417/4/98138
ML1	Integrated Circuit SN7470N	445/4/98010/016

5.17 Isolating Amplifier (630/1/14541)

Resistors

R.No.	Value ohms	Tol. ± %	Rating Watts	Maker and Type	Part No.
1	330	10	$\frac{1}{4}$	Erie 16	403/4/78168/081
2	4.7k	10	$\frac{1}{4}$	Erie 16	403/4/78168/137
3	10k	10	$\frac{1}{4}$	Erie 16	403/4/78168/153
4,7	470	10	$\frac{1}{4}$	Erie 16	403/4/78168/089
5,6	5.6k	10	$\frac{1}{4}$	Erie 16	403/4/78168/141
8	220	10	$\frac{1}{4}$	Erie 16	403/4/78168/073

Miscellaneous

Circuit Ref.	Description	Part No.
C1, C4, C5	Capacitor, .001uF, -20%+40%, Ceramic, Hi-k	400/4/98260/016
VT1, VT2	Transistor, 2S512, Texas Insts.	417/4/98138
F1,F2,F3	UHF Min. feed-thro' Ceramicon Erie CFT3000	400/4/98266
	Board Component	630/1/14540

5.18 Regulator (630/1/14608)

Resistors

R.No.	Value ohms	Tol. \pm %	Rating Watts	Maker and Type	Part No.
1,3,4	4.7k	10	$\frac{1}{4}$	Erie 16	403/4/78168/137
2	10k	10	$\frac{1}{4}$	Erie 16	403/4/78168/153
5	1.2k	10	$\frac{1}{4}$	Erie 16	403/4/78168/109
6	1.8k	10	$\frac{1}{4}$	Erie 16	403/4/78168/117
7	820	10	$\frac{1}{4}$	Erie 16	403/4/78168/101
8	200	5		Welwyn AW 3101	403/4/78220/025

Capacitors

C.No.	Value uF	Tol. \pm %	V.Wkg.	Maker and Type	Part No.
1, 5	47		25	Plessey Electrolytic	402/1/01201/001
2, 3	100		20	Tantalum	402/8/50834/017
4	.05		250	Hunts W97	400/4/98507/010

Miscellaneous

Circuit Ref.	Description	Part No.
RV1	Potentiometer 1k ohms	404/1/00405/005
D1	Diode, Zener, BZY88/C5V6	415/4/98328
MR1	Bridge, diode	415/4/98164
VT2	Transistor, OC35, Mullard	417/4/98108/002
VT3	Transistor, ACY19, Mullard	417/4/98170
VT4	Transistor, OC200, Mullard	417/4/98190
	Reg. Board Assy.	630/1/14606

5.19 Meter Amplifier (630/1/17742)

Resistors

R.No.	Value ohms	Tol. \pm %	Rating Watts	Maker and Type	Part No.
1	Selection on test				
2	12k	10	$\frac{1}{4}$	Erie 16	403/4/78168/157
3	56k	10	$\frac{1}{4}$	Erie 16	403/4/78168/191
4	1.2k	10	$\frac{1}{4}$	Erie 16	403/4/78168/109

5	150	10	$\frac{1}{4}$	Erie 16	403/4/78168/065
6	8.2k	10	$\frac{1}{4}$	Erie 16	403/4/78168/149
8	100	10	$\frac{1}{4}$	Erie 16	403/4/78168/057
9	560	10	$\frac{1}{4}$	Erie 15	403/4/78257/167
10	150	10	$\frac{1}{4}$	Erie 15	403/4/78257/160

Capacitors

C.No.	Value uF	Tol. \pm %	V.Wkg.	Maker and Type	Part No.
1, 3	50		25	Lemco SM	402/4/98009/039
2	0.1	20	250	Mullard C280	400/4/98268/007

Miscellaneous

Circuit Ref.	Description	Part No.
RV1	Potentiometer 100k	404/1/00405/006
RV2	Potentiometer 1k	404/1/00405/005
D1, D2, D4, D5	Diode IN4148	415/4/98393
D3	Diode Zener 12v. ZF12	415/4/98167/011
VT1	Transistor BCY70	417/4/98267/001
RV3	Potentiometer 250ohm	404/1/00405/008

5.20 A.G.C. Decay Shaper (630/1/17869)

Resistors

R.No.	Value ohms	Tol. \pm %	Rating Watts	Maker and Type	Part No.
1	470	5	.1	Erie 15	403/4/78257/041
2	1k	10	.1	Erie 15	403/4/78257/170
3, 4	2.2k	10	.1	Erie 15	403/4/78257/174
5, 6	47k	10	.1	Erie 15	403/4/78257/190
7	100k	5	.1	Erie 15	403/4/78257/243
8	560k	10	.1	Erie 15	403/4/78257/203
9, 10	1.5k	10	.1	Erie 15	403/4/78257/172

Miscellaneous

Circuit Ref.	Description	Part No.
RV1	Potentiometer Lin. 1k \pm 20%	404/1/00405/010
D1	Zener Diode 4.7V \pm 5%	415/4/98167/001
D2	Diode IN4148	415/4/98393
VT1, VT2	Transistor BCY70	417/4/98267/001

6. DRAWINGS AND ILLUSTRATIONS

Fig. 1	PR155 Chassis Layout
Fig. 2	PR155 Schematic Diagram
Fig. 3	PR155 RF Turret
Fig. 4	Turret Comp. 1: R.F. Filters
Fig. 5	Module 1: R.F. Amplifier
Fig. 6	Module 2: First Mixer
Fig. 7	Module 3: First local Osc.
Fig. 8	Module 10: Spectrum Generator Mk II
Fig. 9	Interpolating Osc.
Fig. 10	Turret Comp. 2: MHz Selector
Fig. 11	Turret Board G: Phase Splitters and Modulator
Fig. 12	Comp. Board H: Phase Detector
Fig. 13	3 Board J: DC Amp./Reactor Sweep Gen.
Fig. 14	Module 4: First IF Amplifier/2nd Mixer
Fig. 15	Module 5: 2nd IF Amplifier/3rd Mixer
Fig. 16	Module 11: 10.6/10.8 MHz Generator Mk II
Fig. 17	Module 7: 3rd IF Amplifier/Detector
Fig. 18	Module 8: AGC Amplifier/Detector
Fig. 19	Module 9: Audio Amplifier
Fig. 20	Module 12: 100 kHz Divider/Calibrator
Fig. 21	Beat Frequency Osc.
Fig. 22	Isolating Amplifier
Fig. 23	Power Supply Regulator
Fig. 24	Meter Amplifier and AGC Decay Shaper

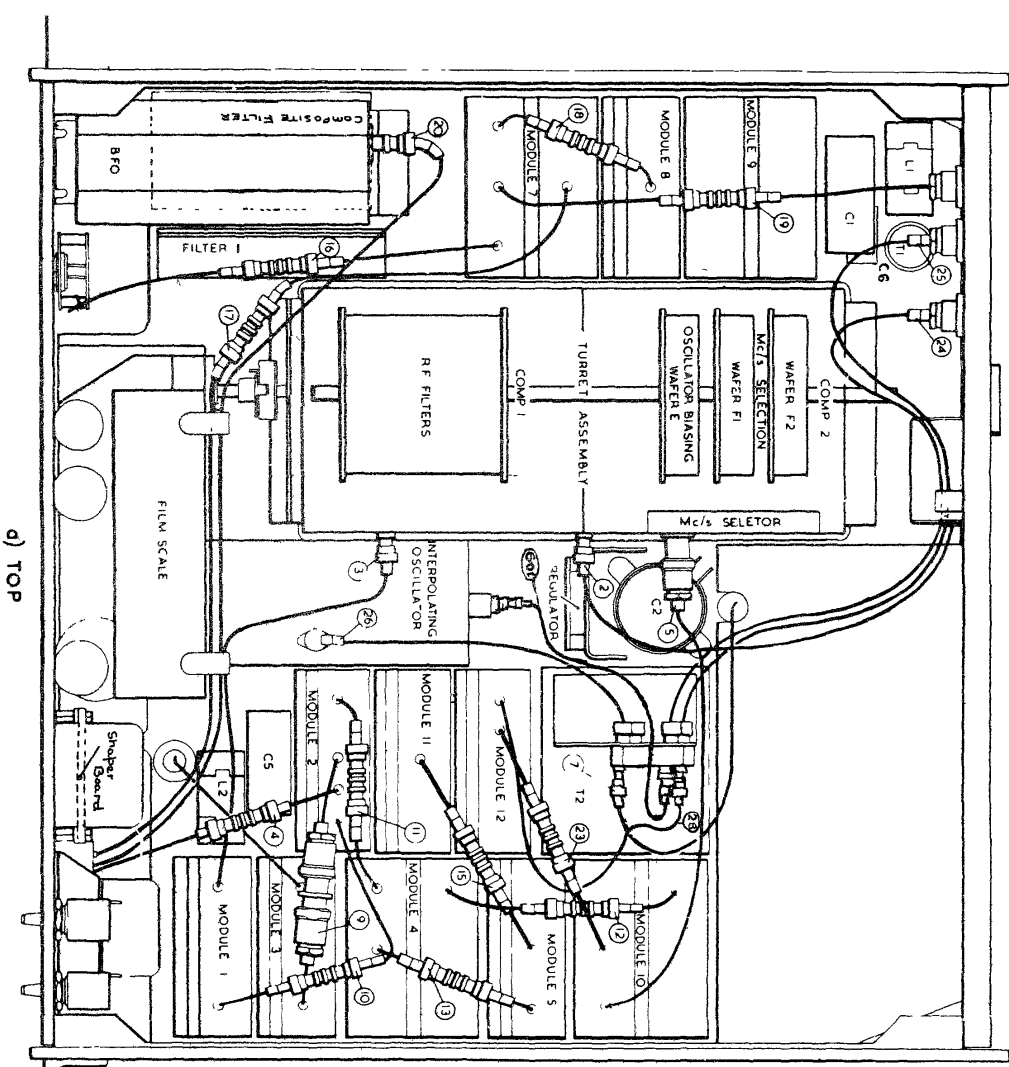

d) TOP

FIG. 1 PRIEST CHASSIS LAYOUT

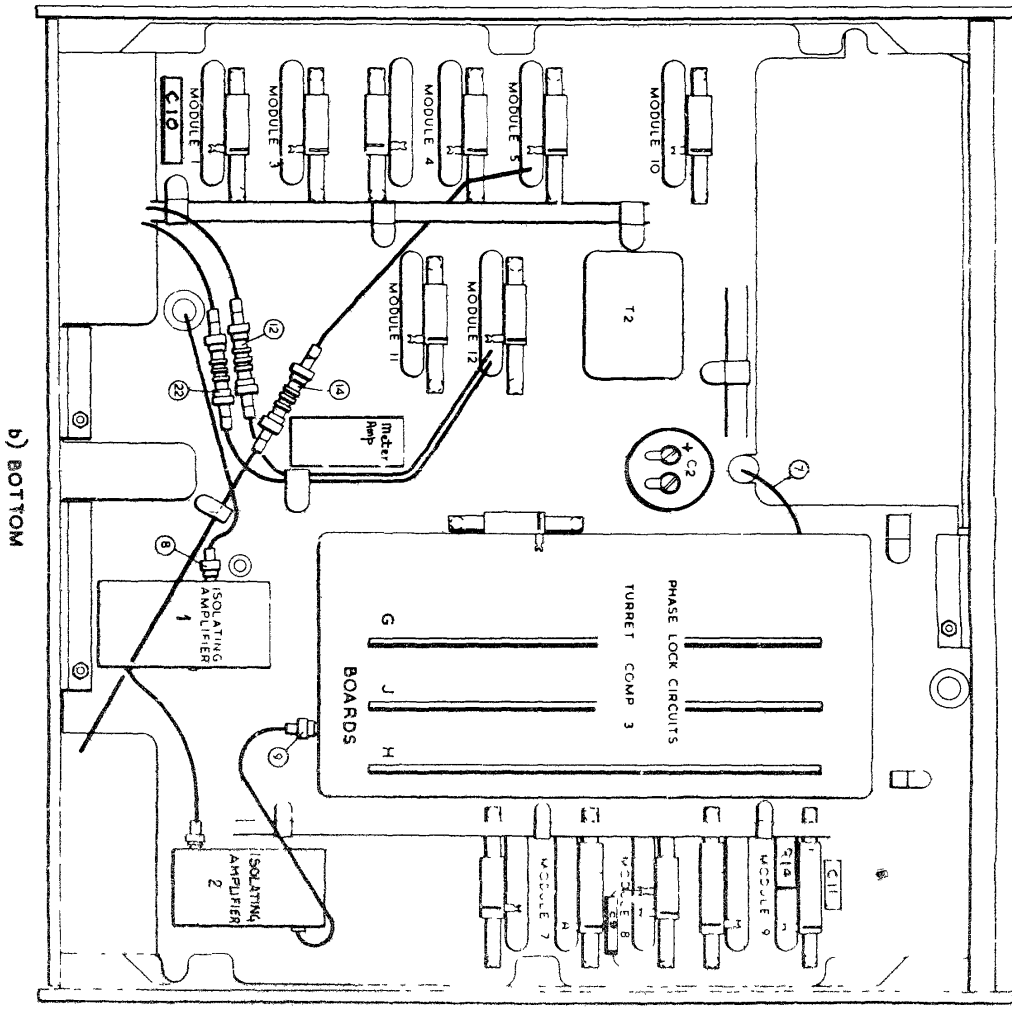

d) BOTTOM

FIG. 1. CHASSIS

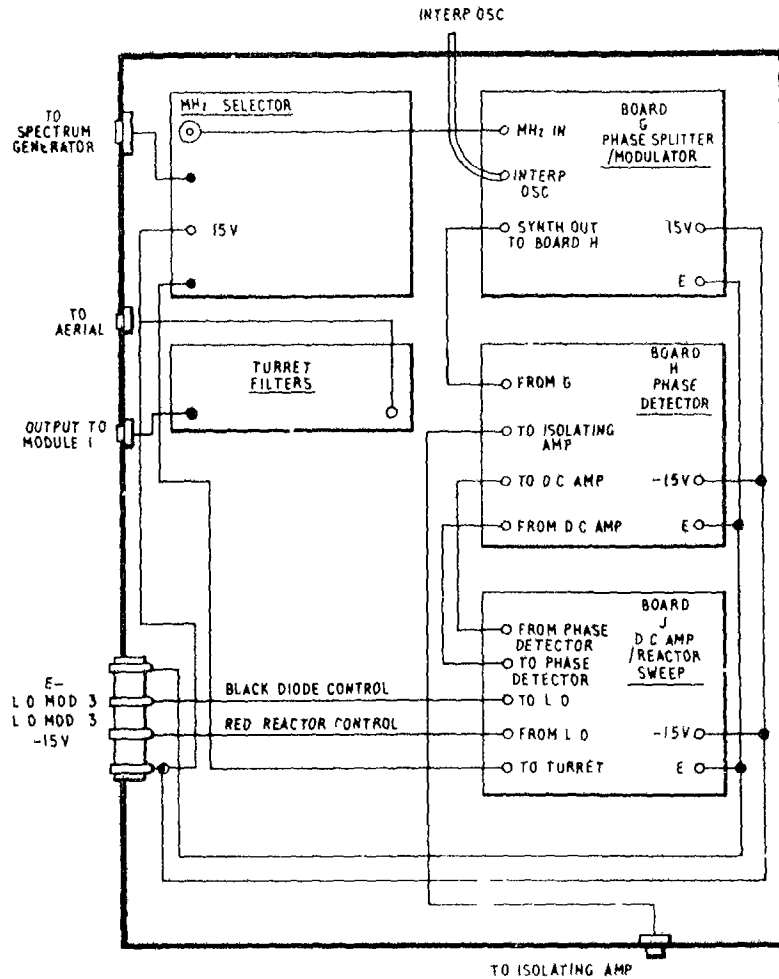

a TURRET INTERCONNECTIONS

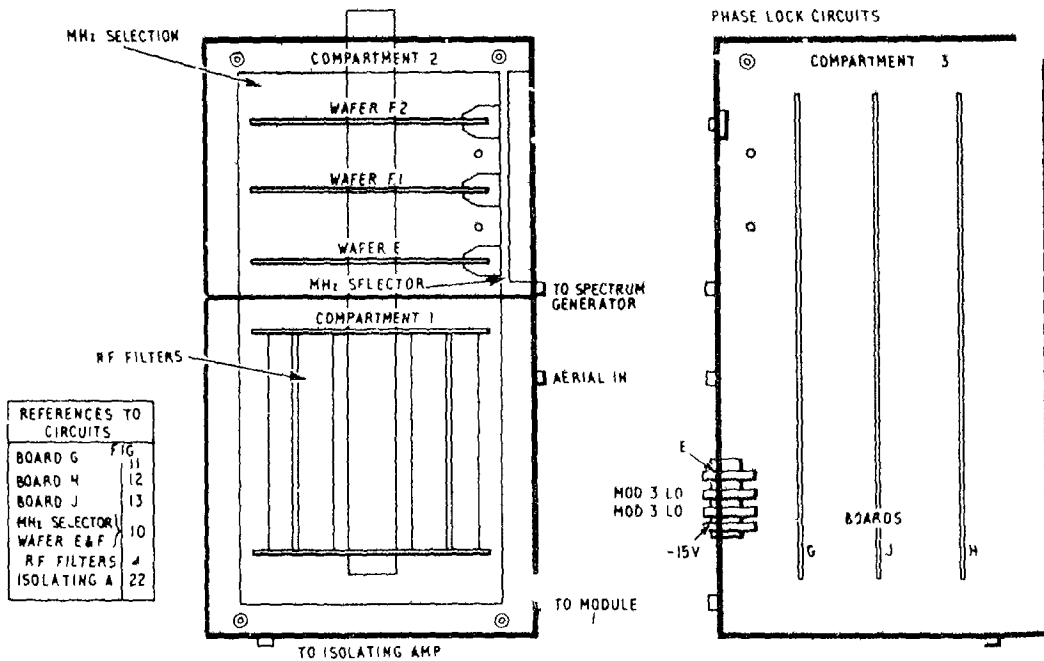

b COMPONENT BOARD POSITIONS

FIG. 3 R.F. TURRET

Modifications										Fig 4	Issue 2
1	2	3	4	5	6	7	8	9	10	11	12

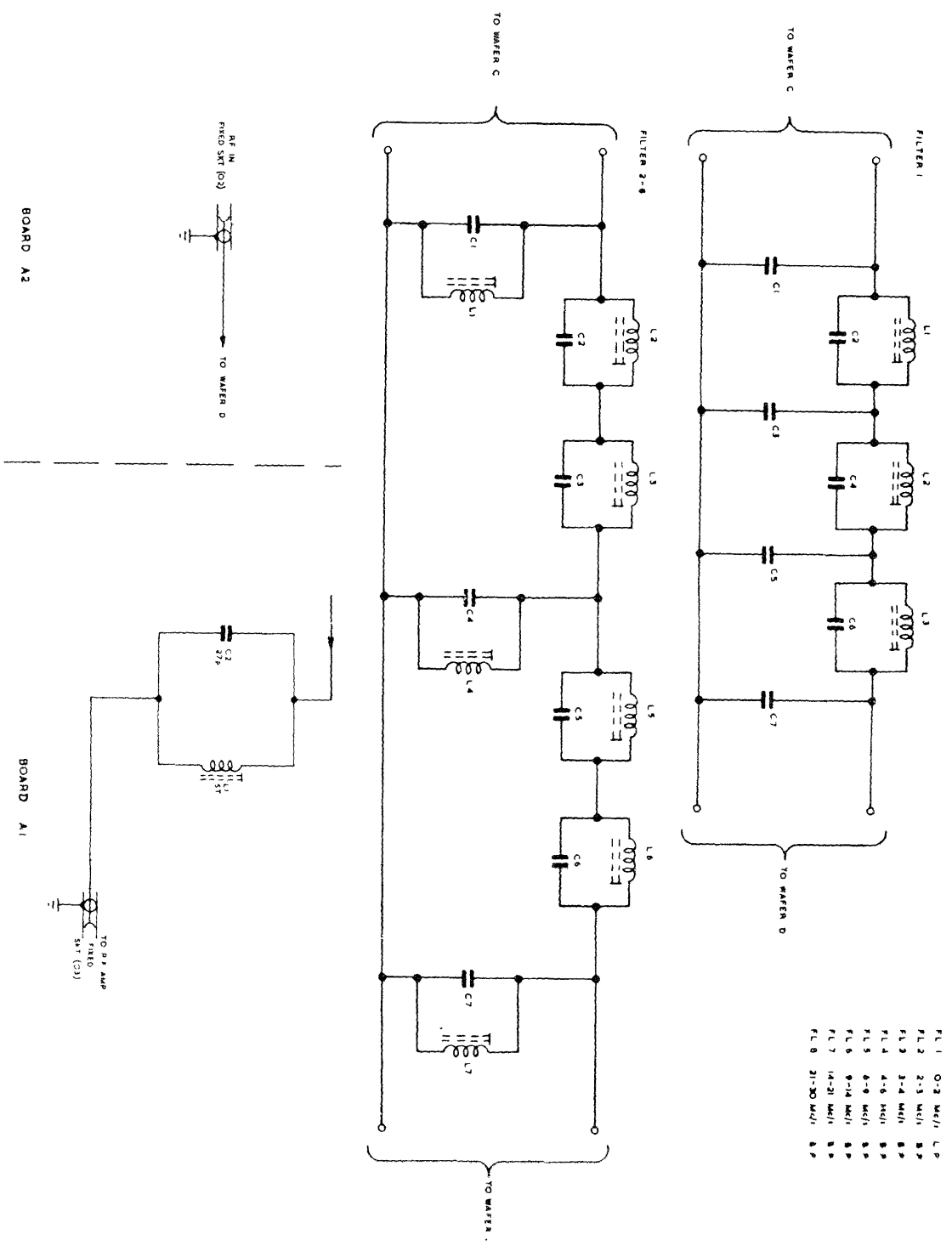

FIG. 4. TURRET COMPARTMENT 1: FILTER CIRCUITS TURRET COMP. 1

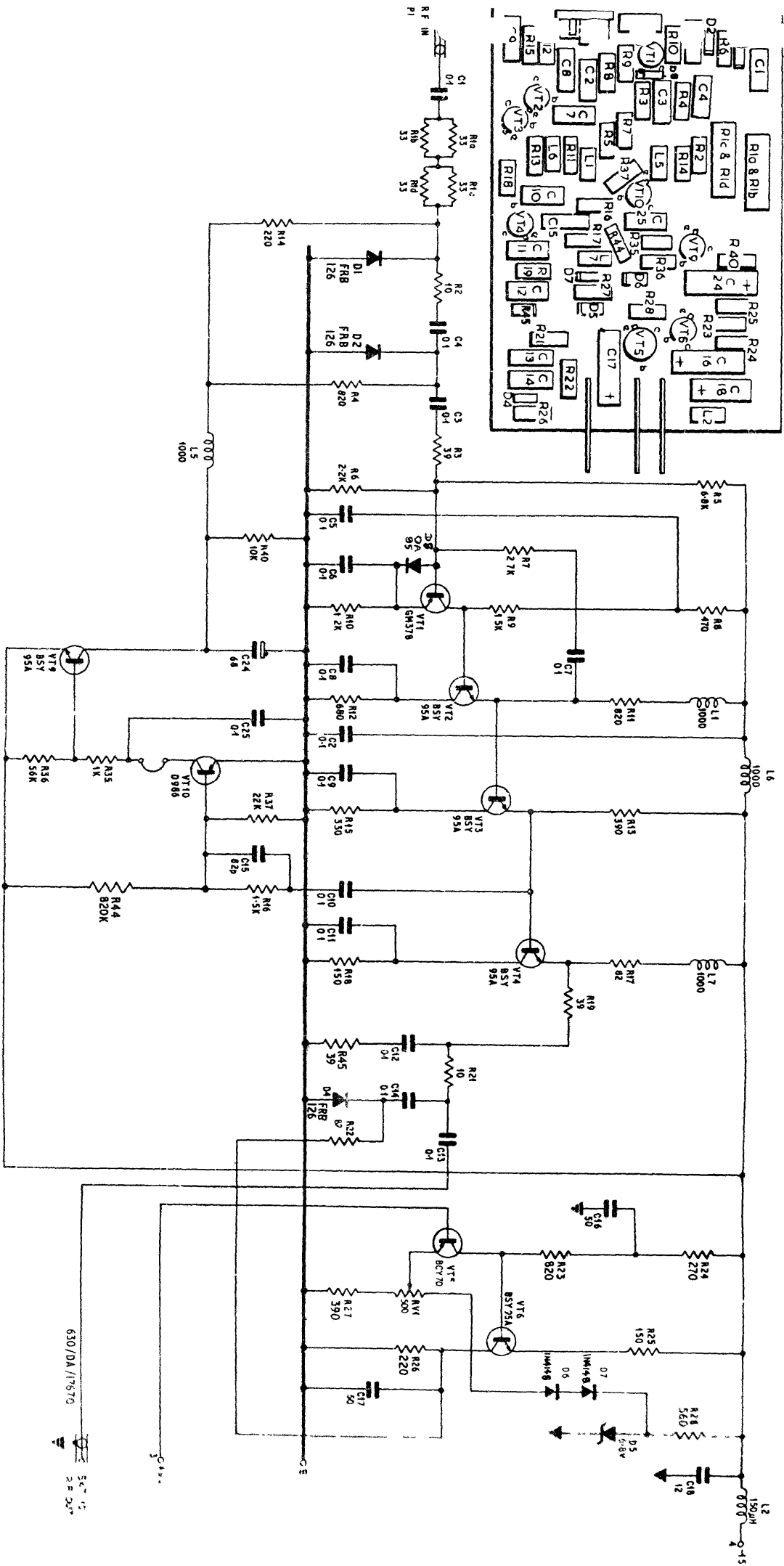
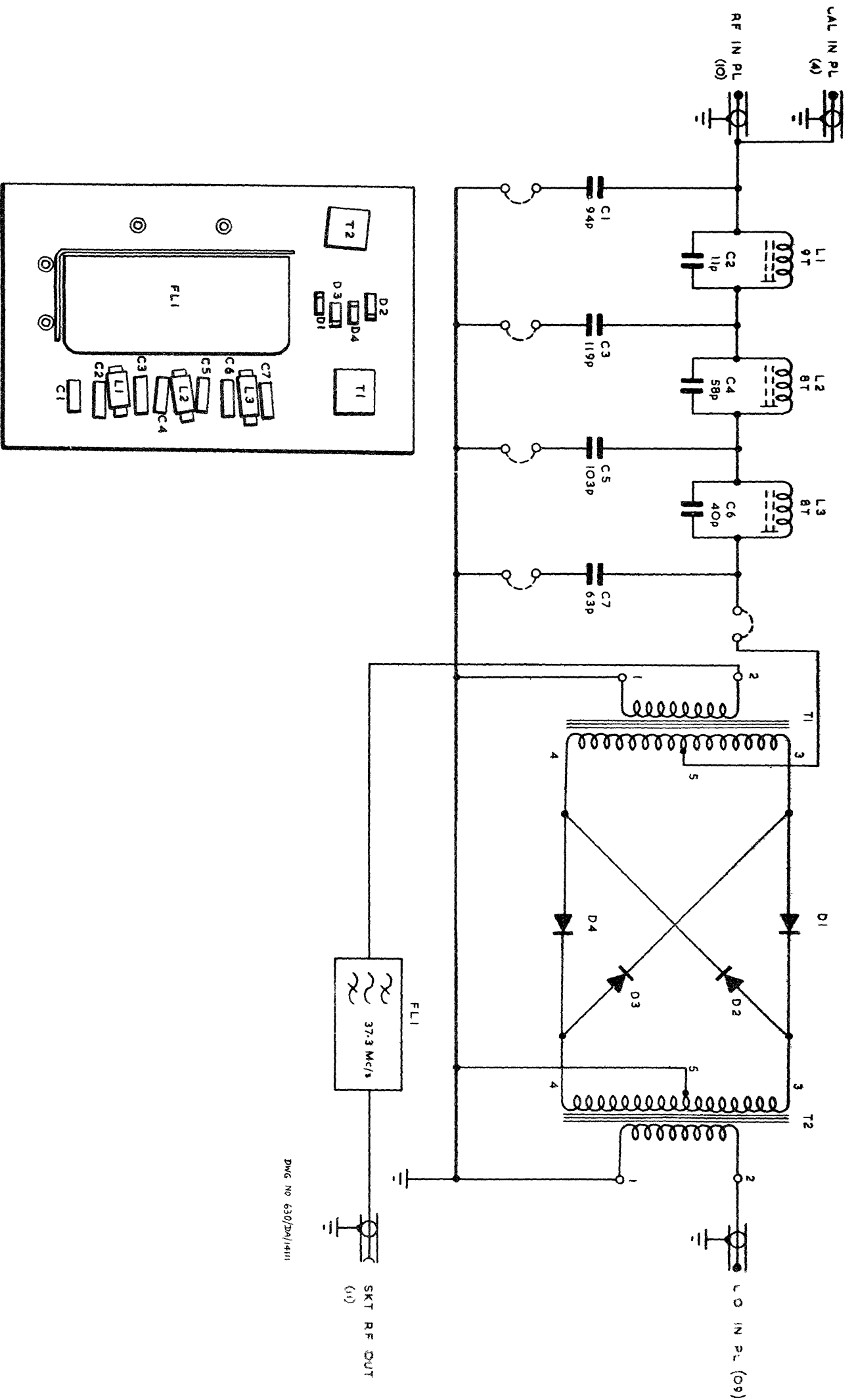

FIG. 5 R F AMPLIFIER MODULE 1 CIRCUIT AND BOARD LAYOUT

FIG. 5 MODULE



1	2	3	4	5	6	7	8	9	10	11	12
Modifications	Fig. 6	Issue. 4									

DWG No 630/14111

FIG. 6. FIRST MIXER : MODULE 2 : CIRCUIT AND BOARD LAYOUT

FIG. 6. MOD 2

DWG NO 630/DN/14111

Modifications: Fig. 2 Issue 4
 1 2 3 4 5 6 7 8 9 10 11 12

FIG. 7. PRIIS FIRST LOCAL OSCILLATOR : MODULE 3 : CIRCUIT AND BOARD LAYOUT

DWG NO 630/1/14443

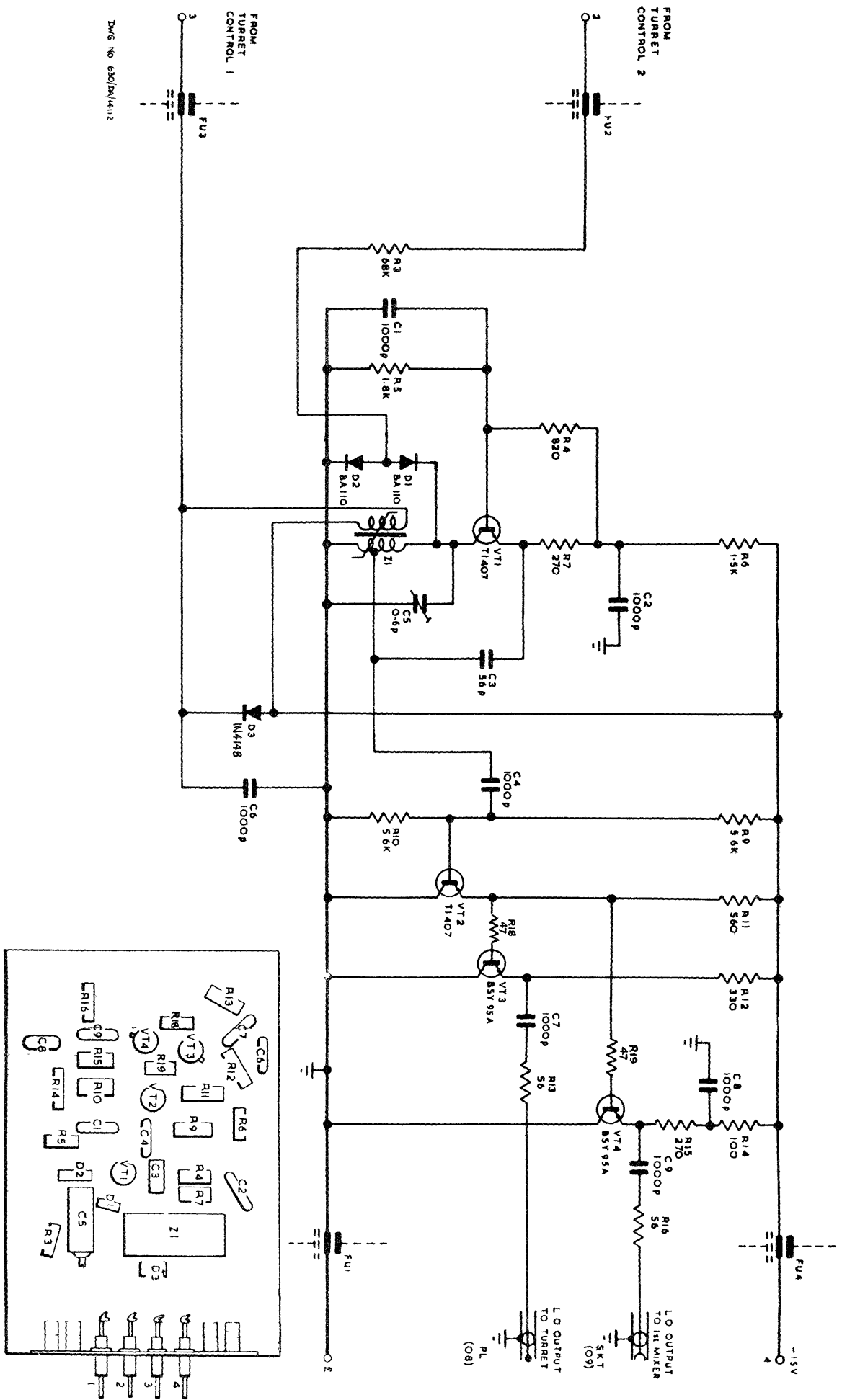

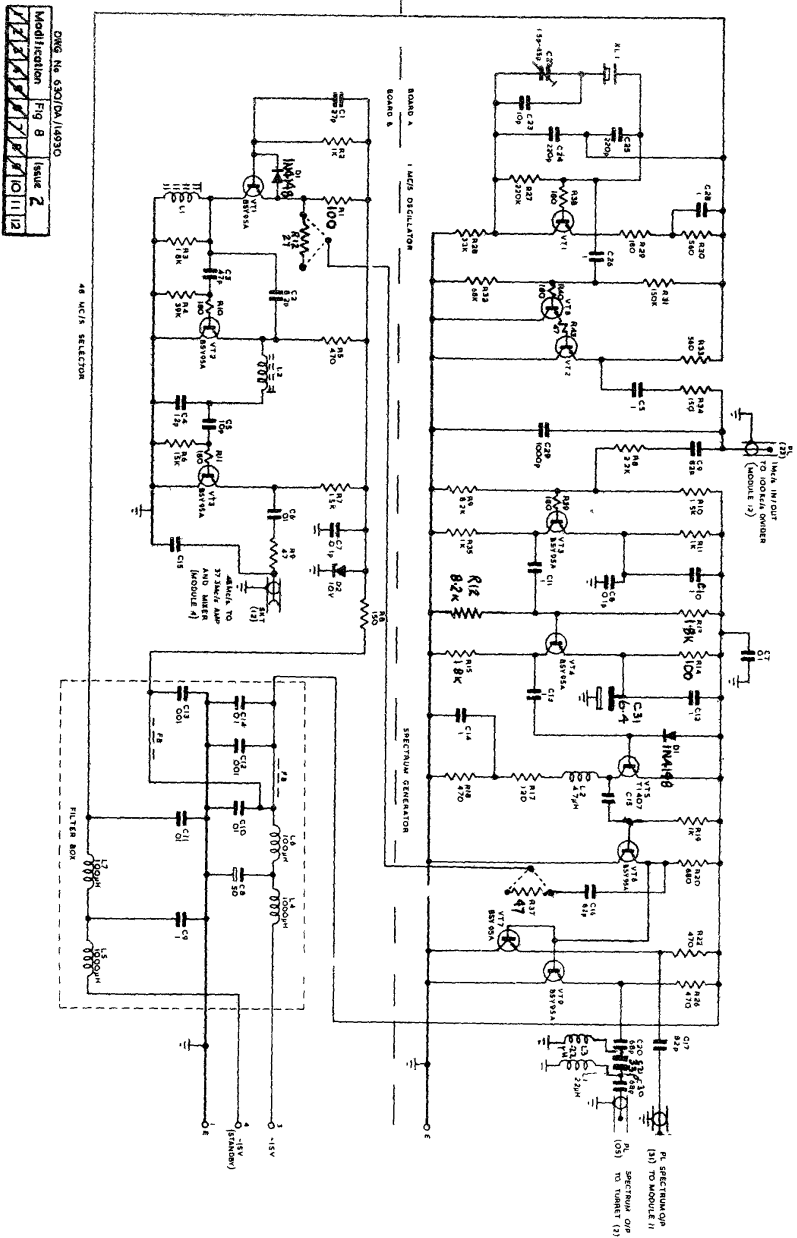

FIG. 8 SPECTRUM GENERATOR/48MHZ SELECTOR MODULE IO MK II

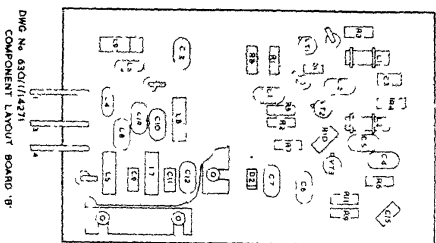
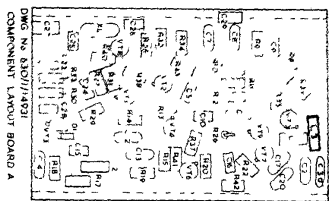
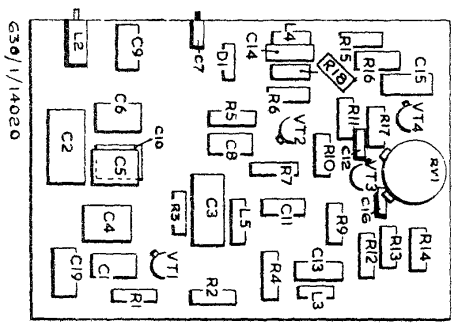
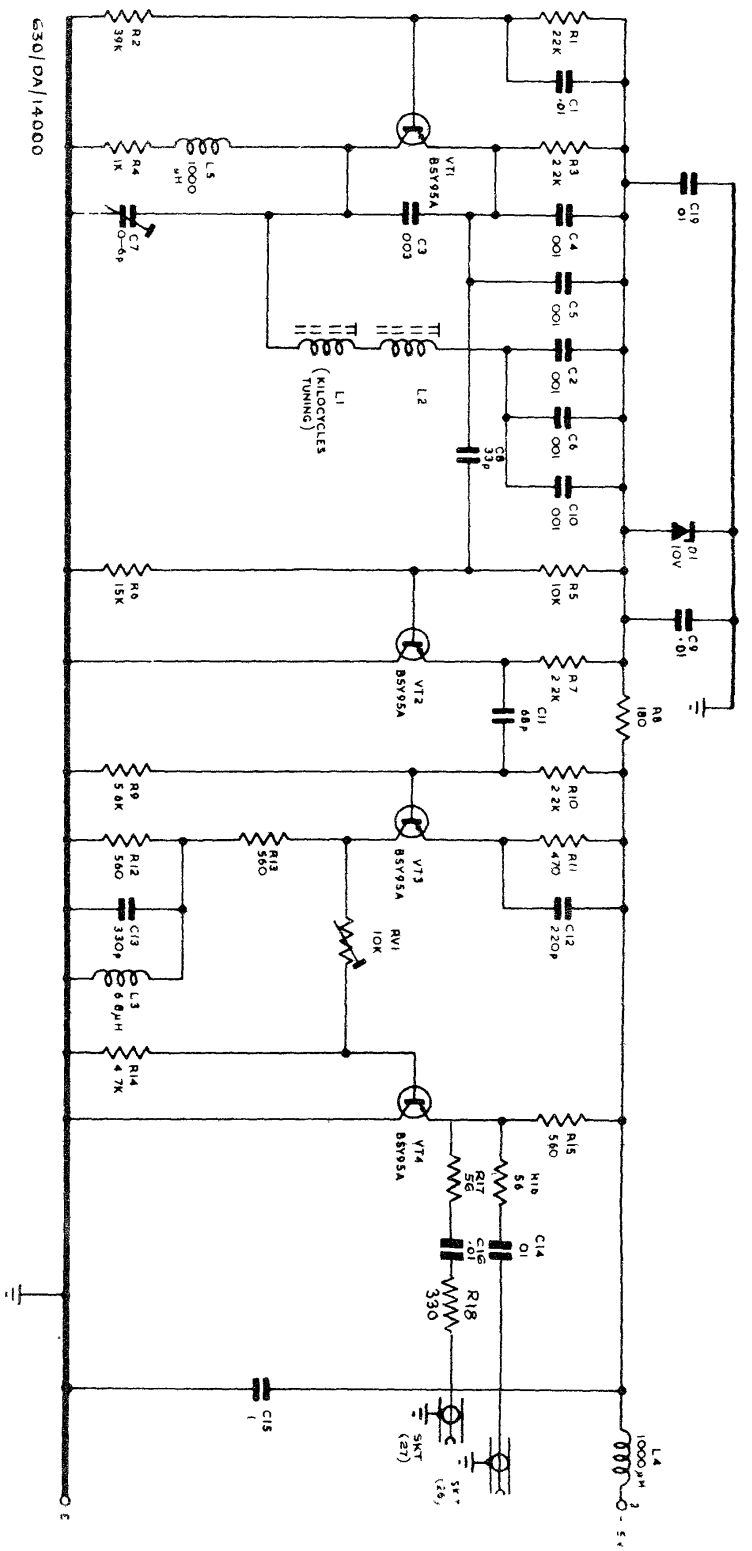

FIG. 9 MODULE IO MK II



Modifications Fig 9 Issue A
 2 3 4 5 6 7 8 9 10 11 12

FIG. 9. INTERPOLATING OSCILLATOR : CIRCUIT AND BOARD LAYOUT FIG. 9. INT. OSC.

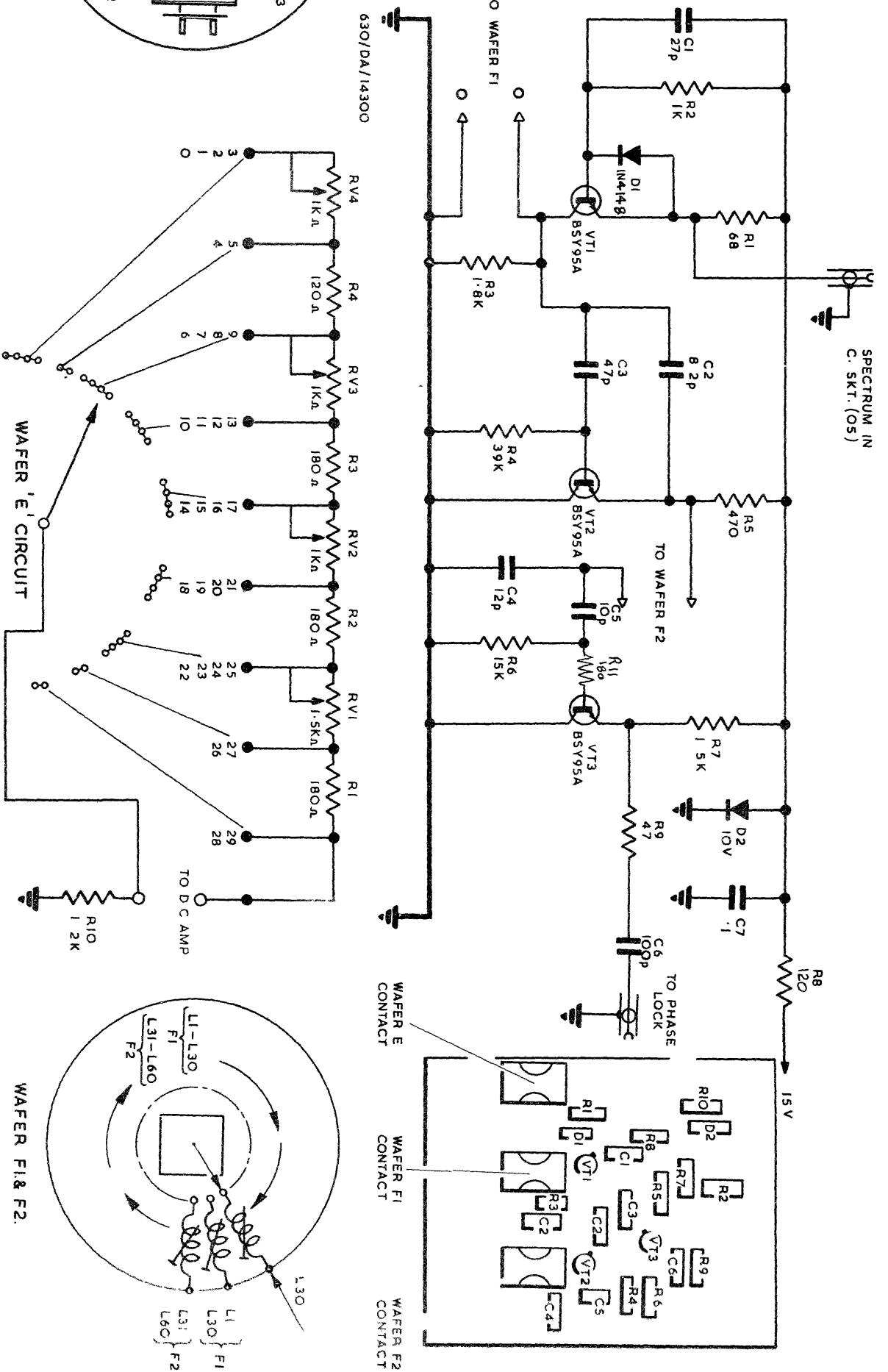
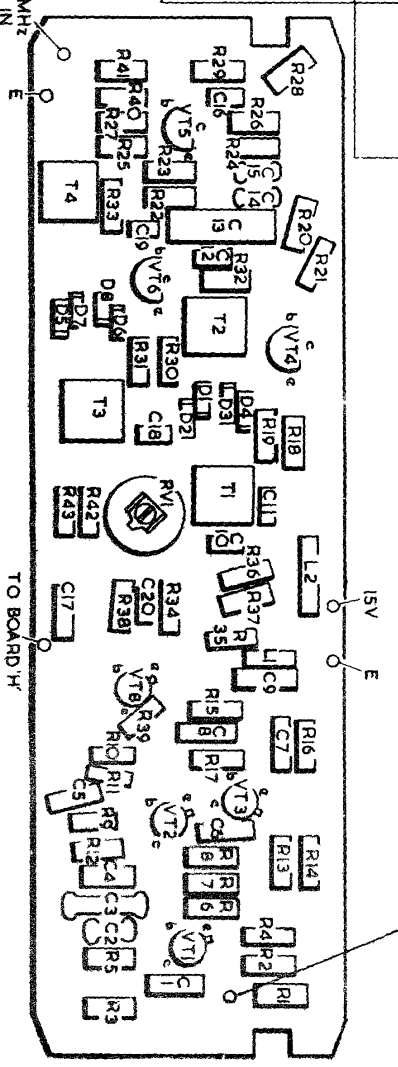
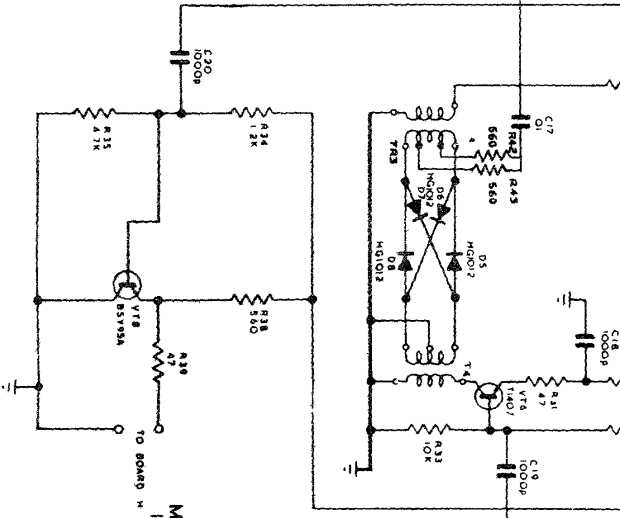
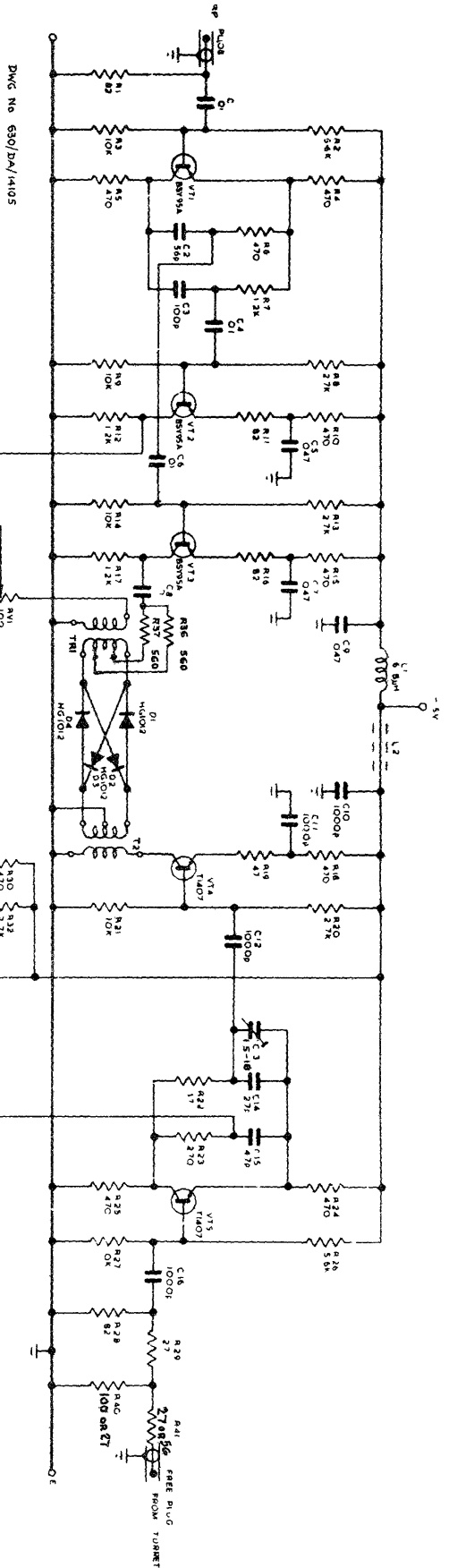

FIG. 10. MC/5 SELECTOR : TURRET COMPARTMENT 2 : CIRCUIT AND BOARD LAYOUT.

FIG. 10. TURRET COMP. 2



See Fig 1 For Overall Mod Stage

FIG. 11. PR155 PHASE SPLITTERS AND MODULATOR, BOARD G : CIRCUIT AND LAYOUT

FIG. 11. TURRET (BOARD G)

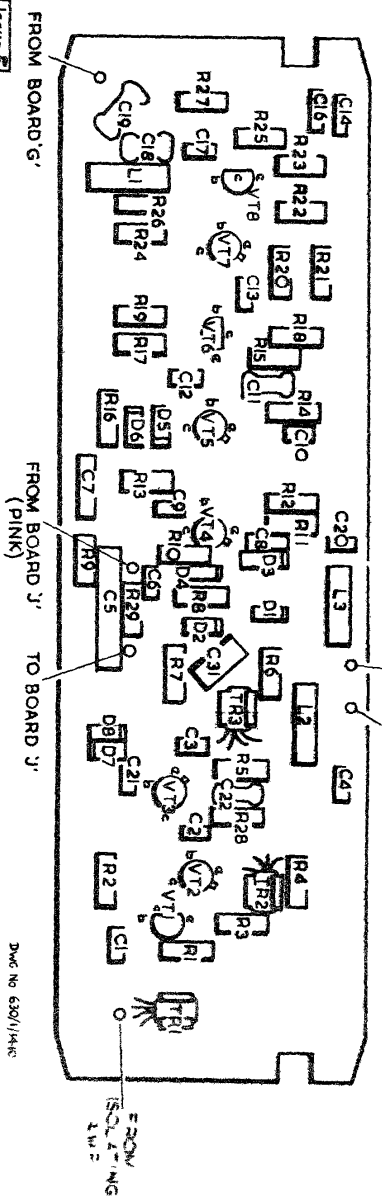
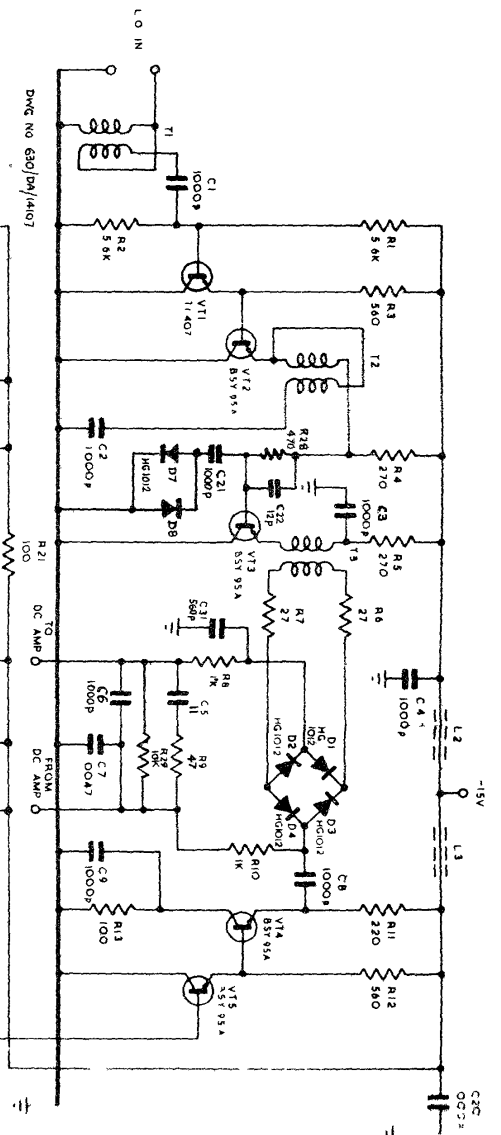

Modifications Fig. 12 Issue 5
 Turret Mod. No. 1
 Embodied

FIG. 12. PR155 PHASE DETECTOR BOARD H : CIRCUIT AND LAYOUT (BOARD H)
 See Fig 1 For Overall Mod. State

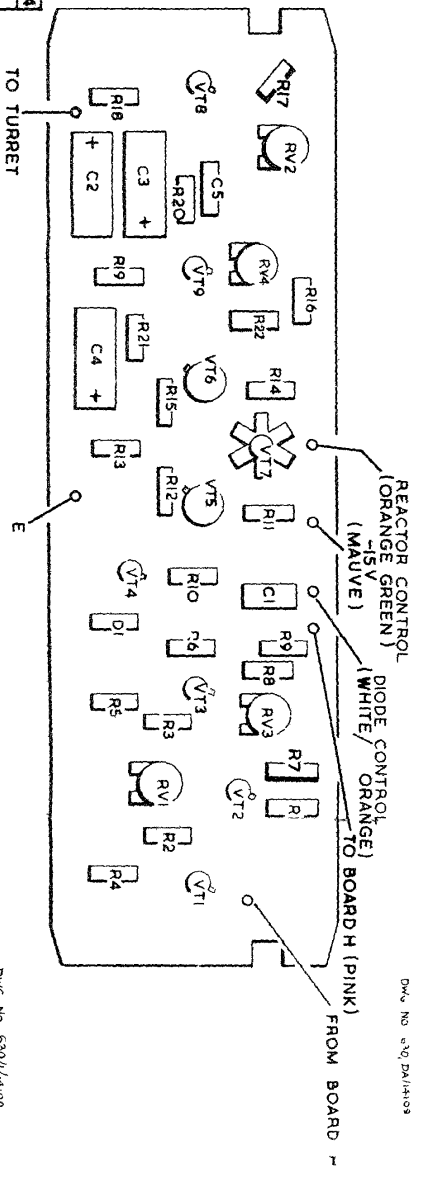
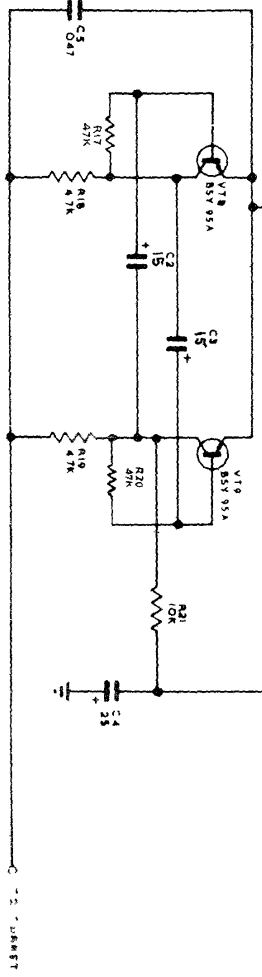
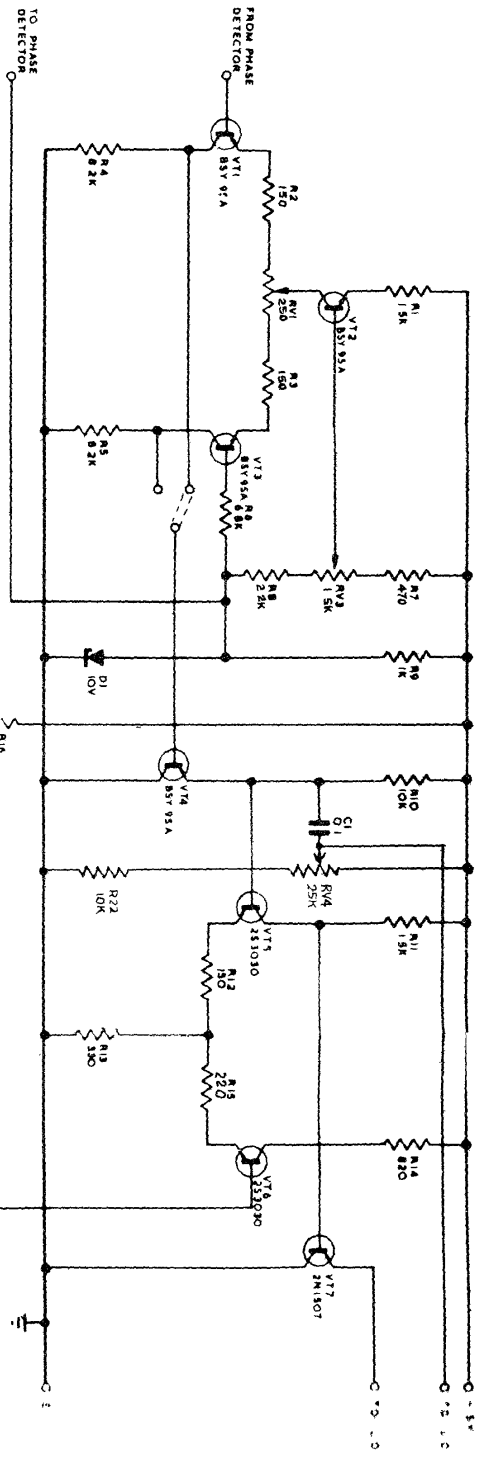

Modifications Fig 13 Issue 4
 Turret Mod. No. 3, 7
 Embodied

See Fig 1 For Overall Mod. State.

DWG NO 630/1/4109

FIG 13 PRIS5 D.C. AMPLIFIER AND REACTOR SWEEP GENERATOR, BOARD J : CIRCUIT AND LAYOUT BOARD J)

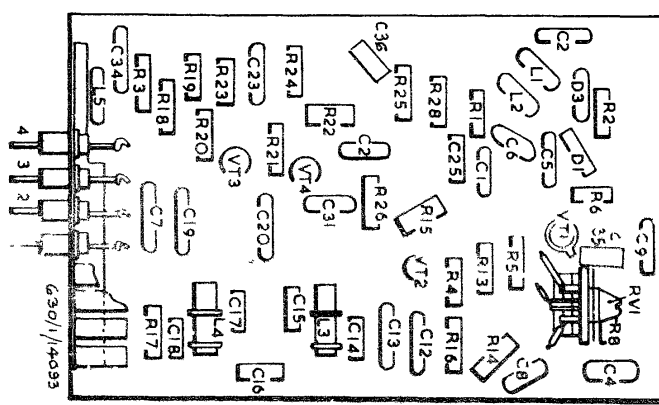
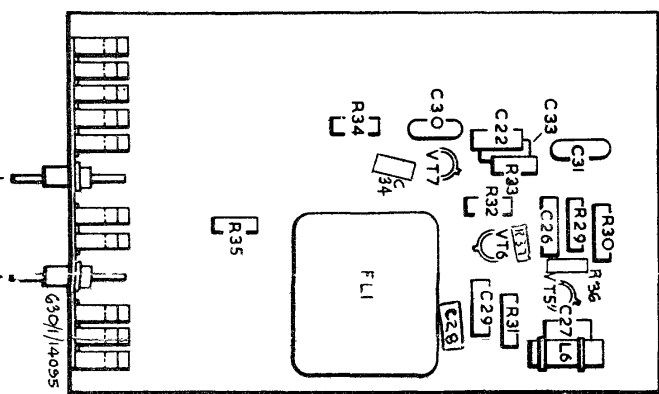
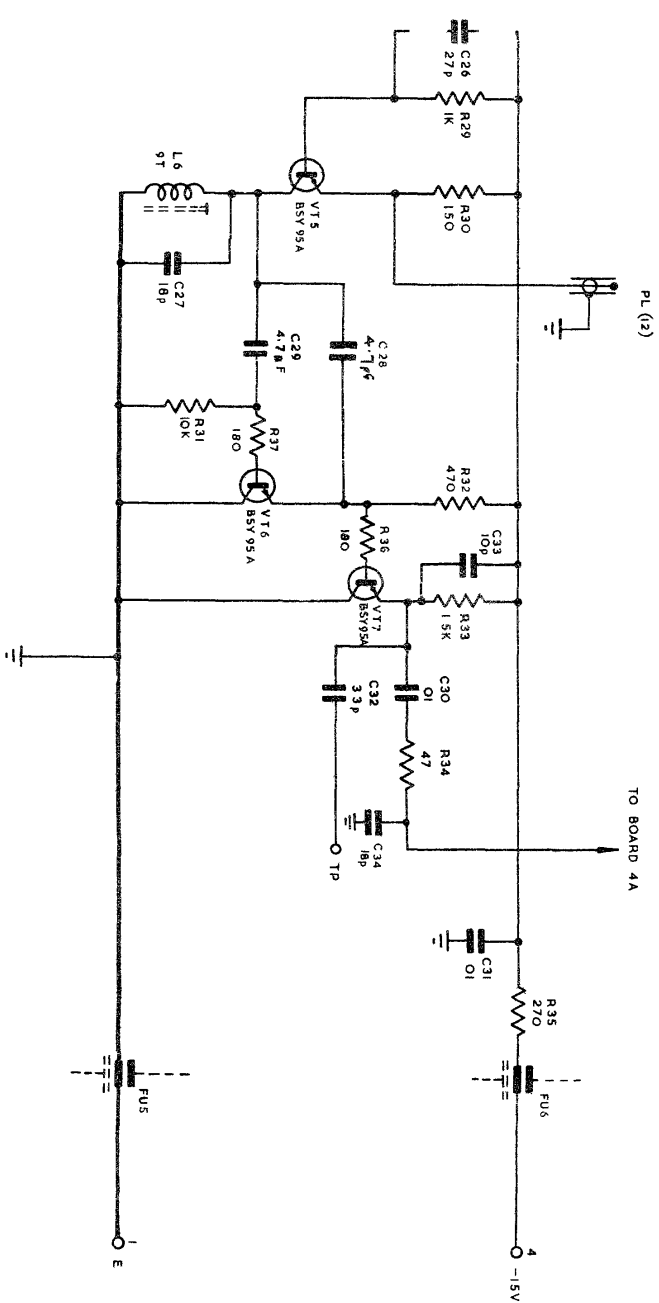
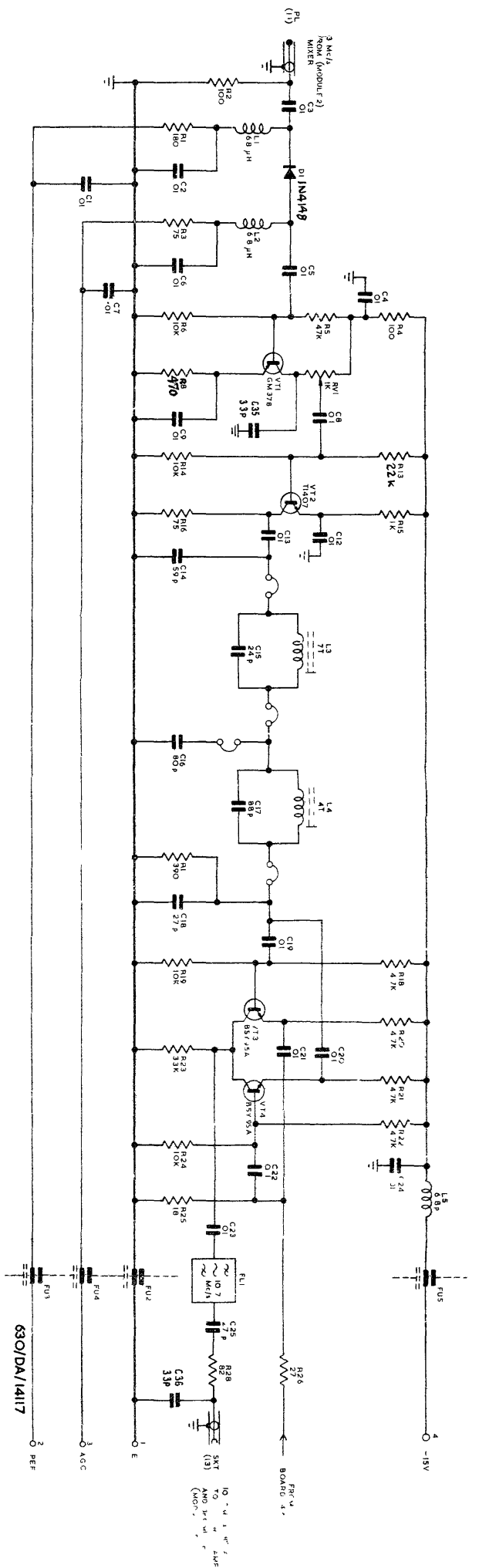

FIG.14. PRISS FIRST I.F. AMPLIFIER AND 2nd. MIXER, MODULE 4 : CIRCUIT AND BOARD LAYOUT

FIG.14 MODULE 4

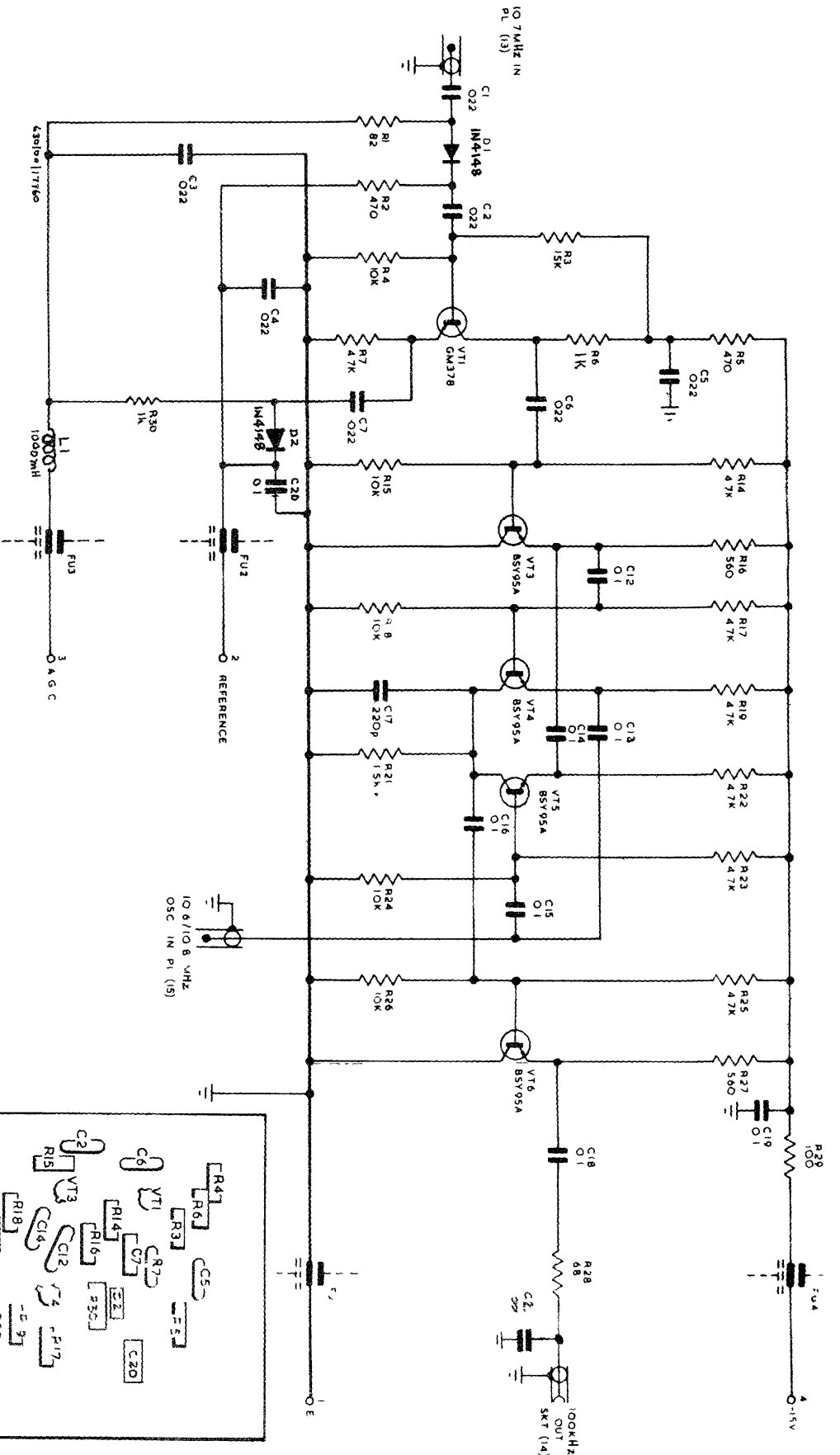

FIG. 15. PRIS5 2nd. I. F. AMPLIFIER AND 3rd MIXER, MODULE 5 : CIRCUIT AND BOARD LAYOUT

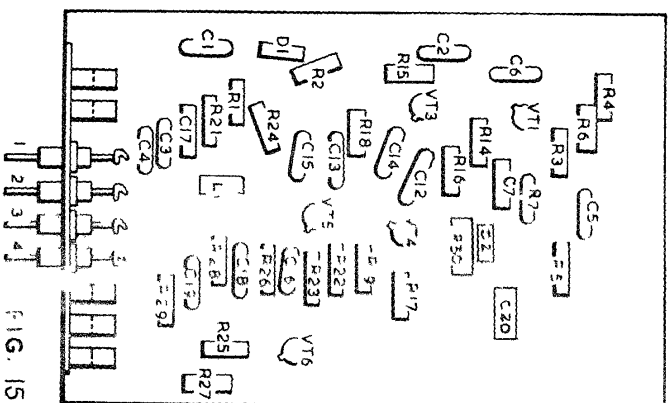

FIG. 15
MODULE 5

Modifications	Fig 16	Issue
1	2	3
2	3	3
3	4	3
4	5	3
5	6	3
6	7	3
7	8	3
8	9	3
9	10	3
10	11	3
11	12	3

DWG NO:530/DW/4938

(b) CIRCUIT DIAGRAM

(c) COMPONENT LAYOUT

DWG NO: 530-4840

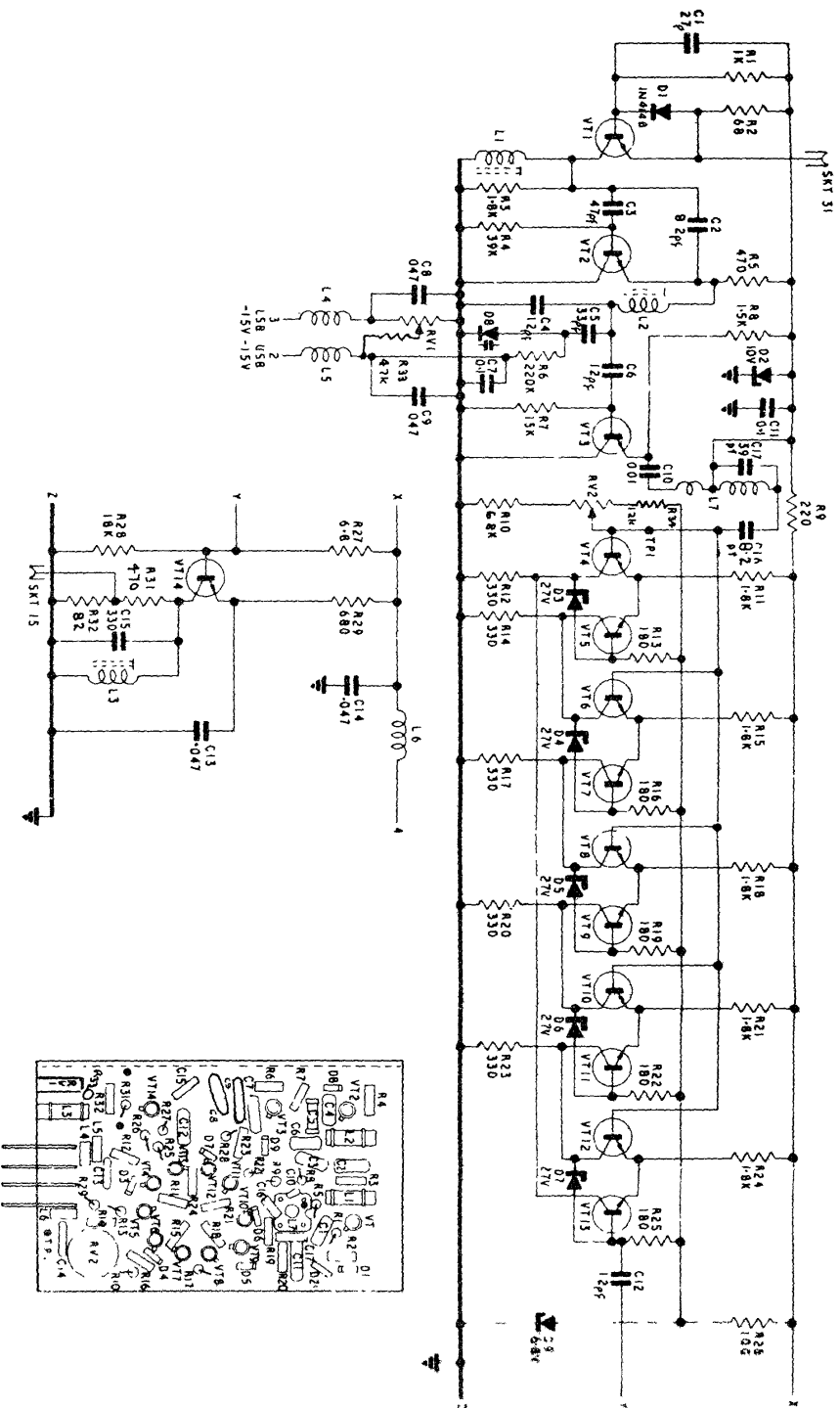
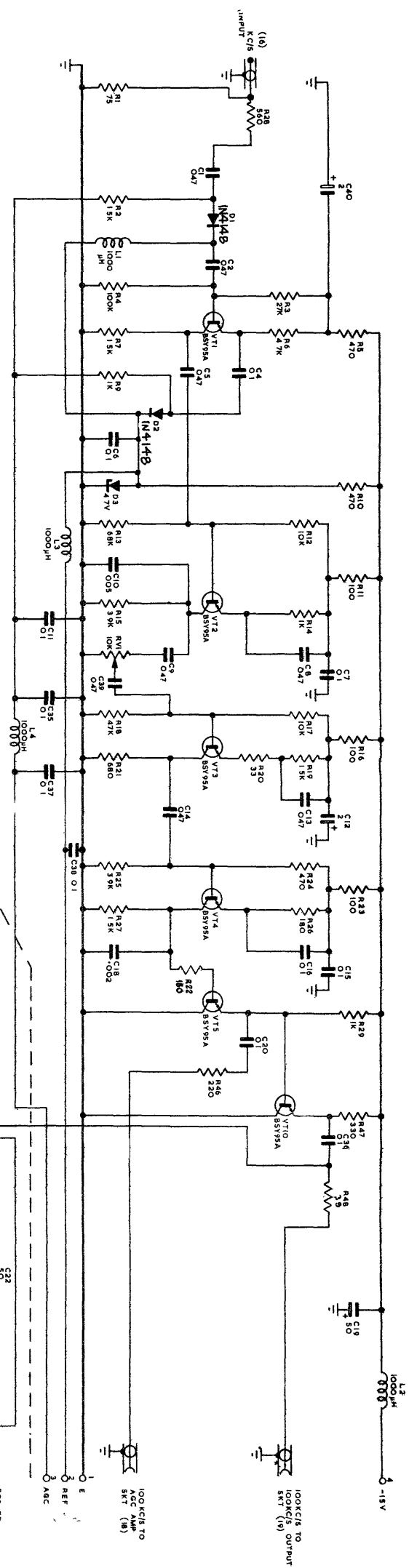
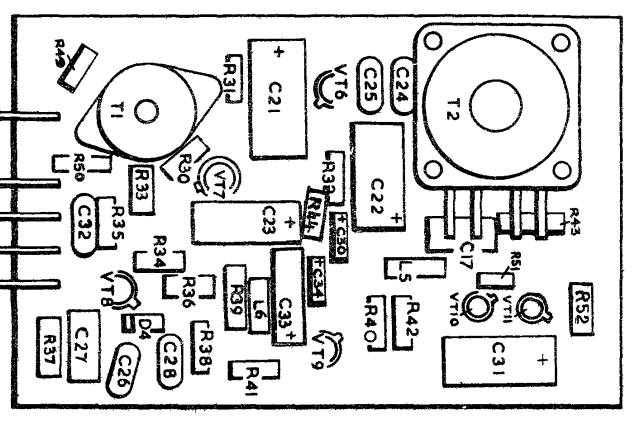

FIG. 16 IO.6/IO.8 MHz GENERATOR (MODULE 1D) MK II

FIG. 16 MODULE 11 MK II



BOARD A
BOARD B



DWG No 630/147774

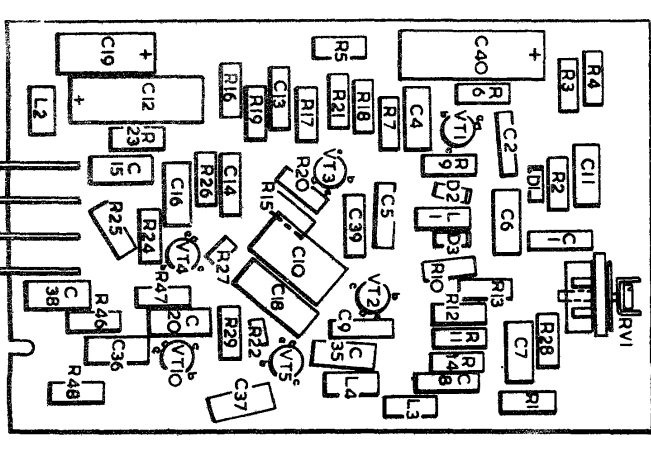

DWG No 630/147771

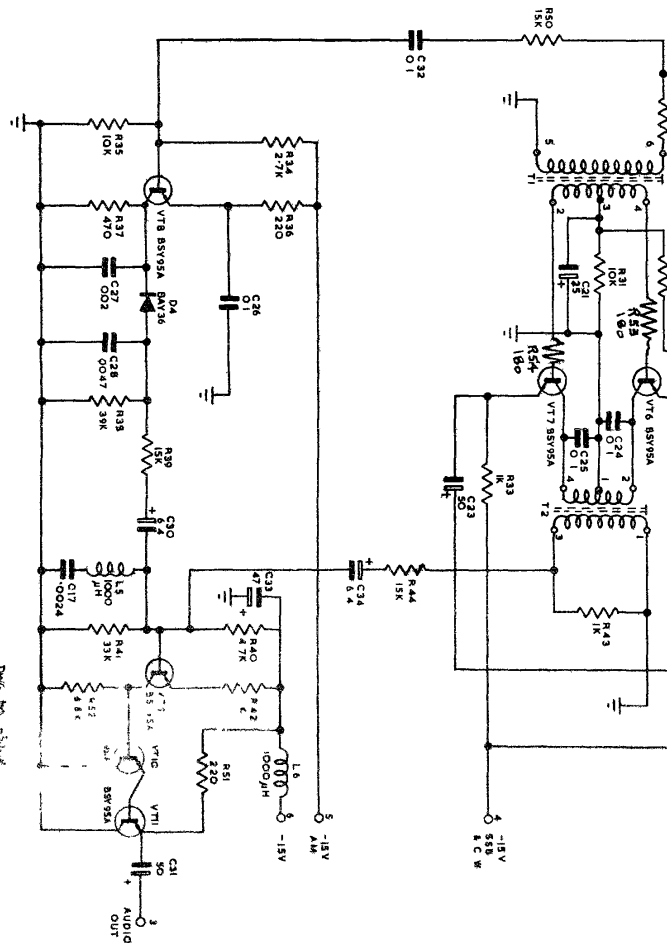

DWG No 630/147771

Modifications Fig. 17 Issue 9
1 2 3 4 5 6 7 8 9 10 11 12

FIG. 17. PR 155 3rd. I. F. AMPLIFIER AND DETECTOR, MODULE 7 : CIRCUIT AND BOARD LAYOUT

FIG 17 MODULE 7

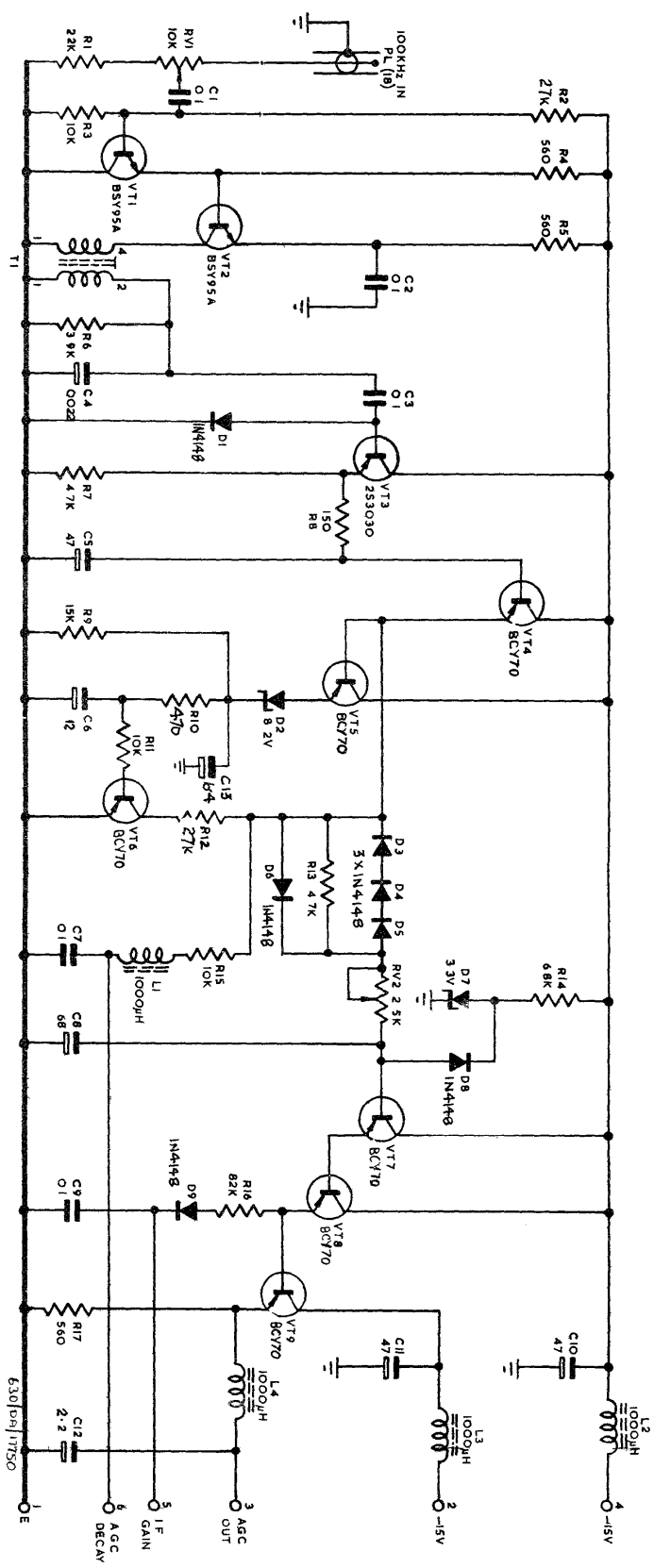

FIG. 18. PR155 A.G.C. AMPLIFIER AND DETECTOR, MODULE 8: CIRCUIT AND BOARD LAYOUT

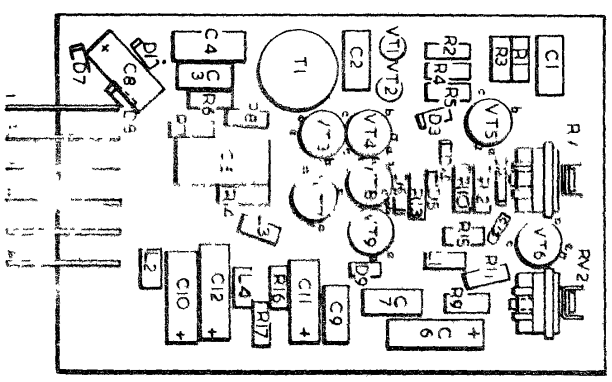

FIG. 19. PR155 A.G.C. E. 8

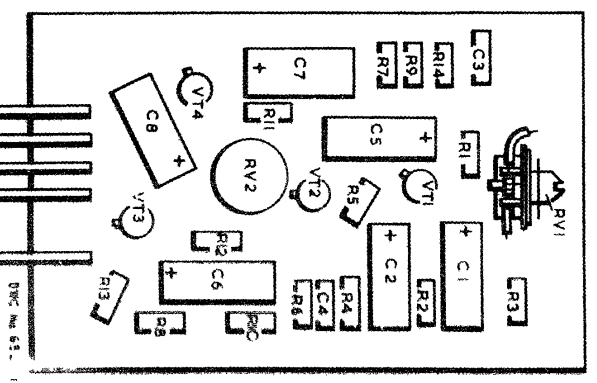
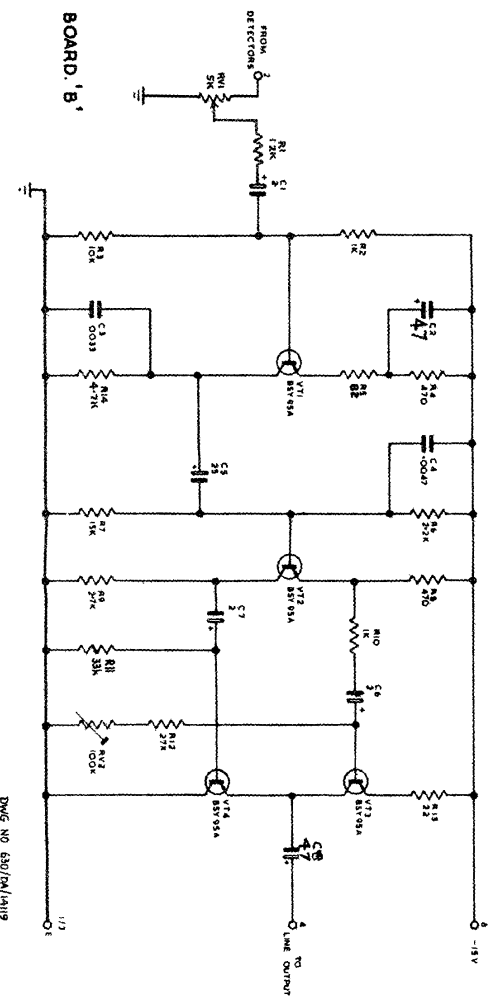
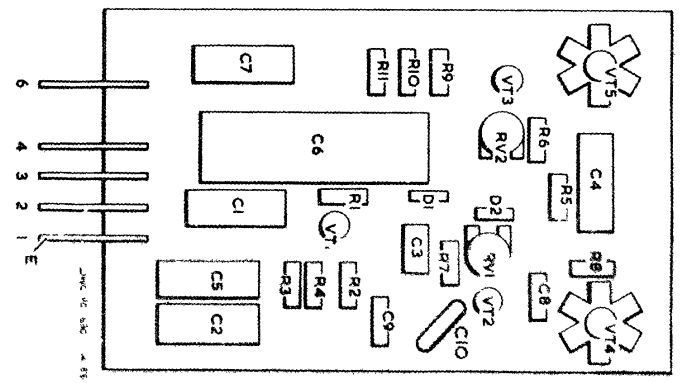
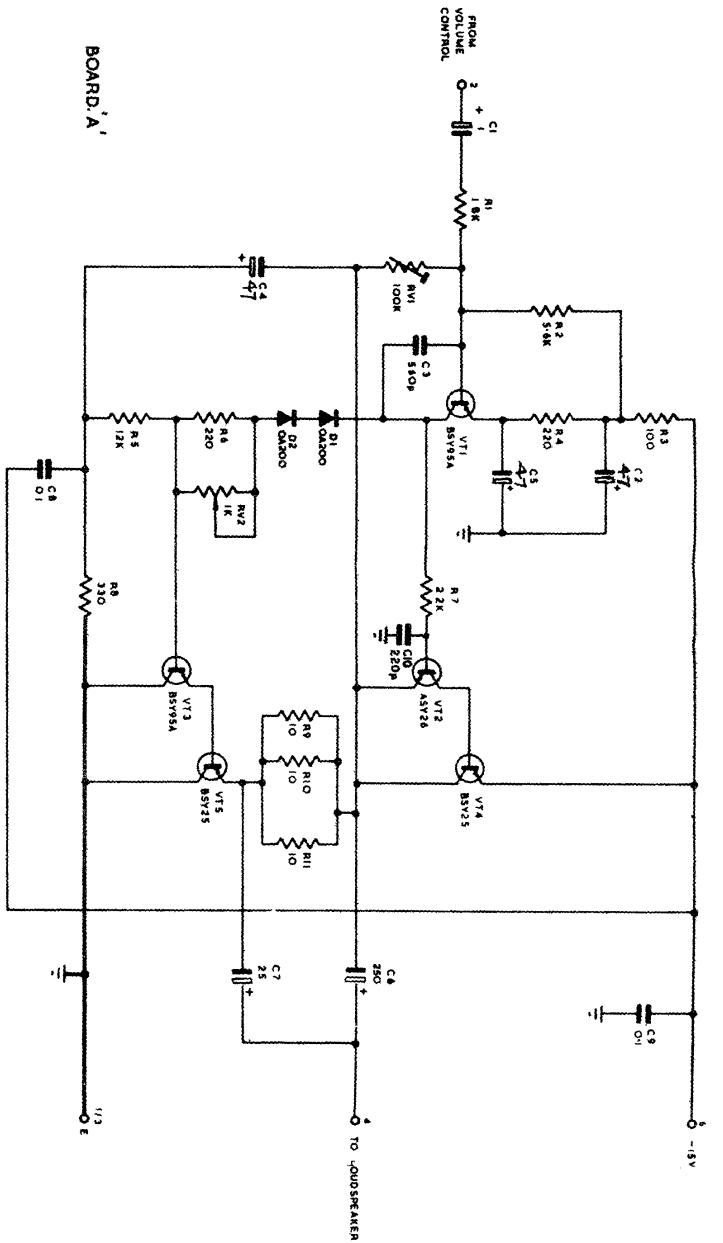
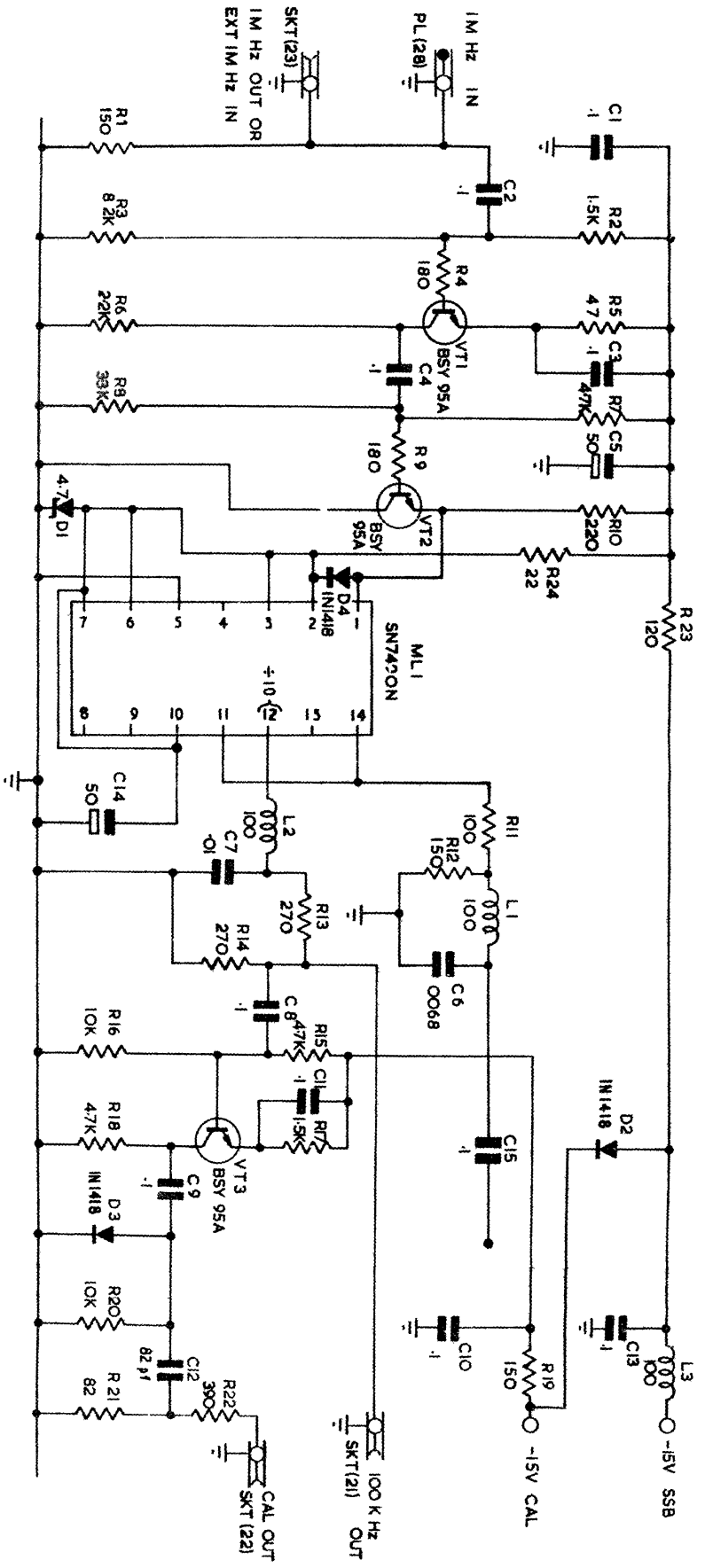
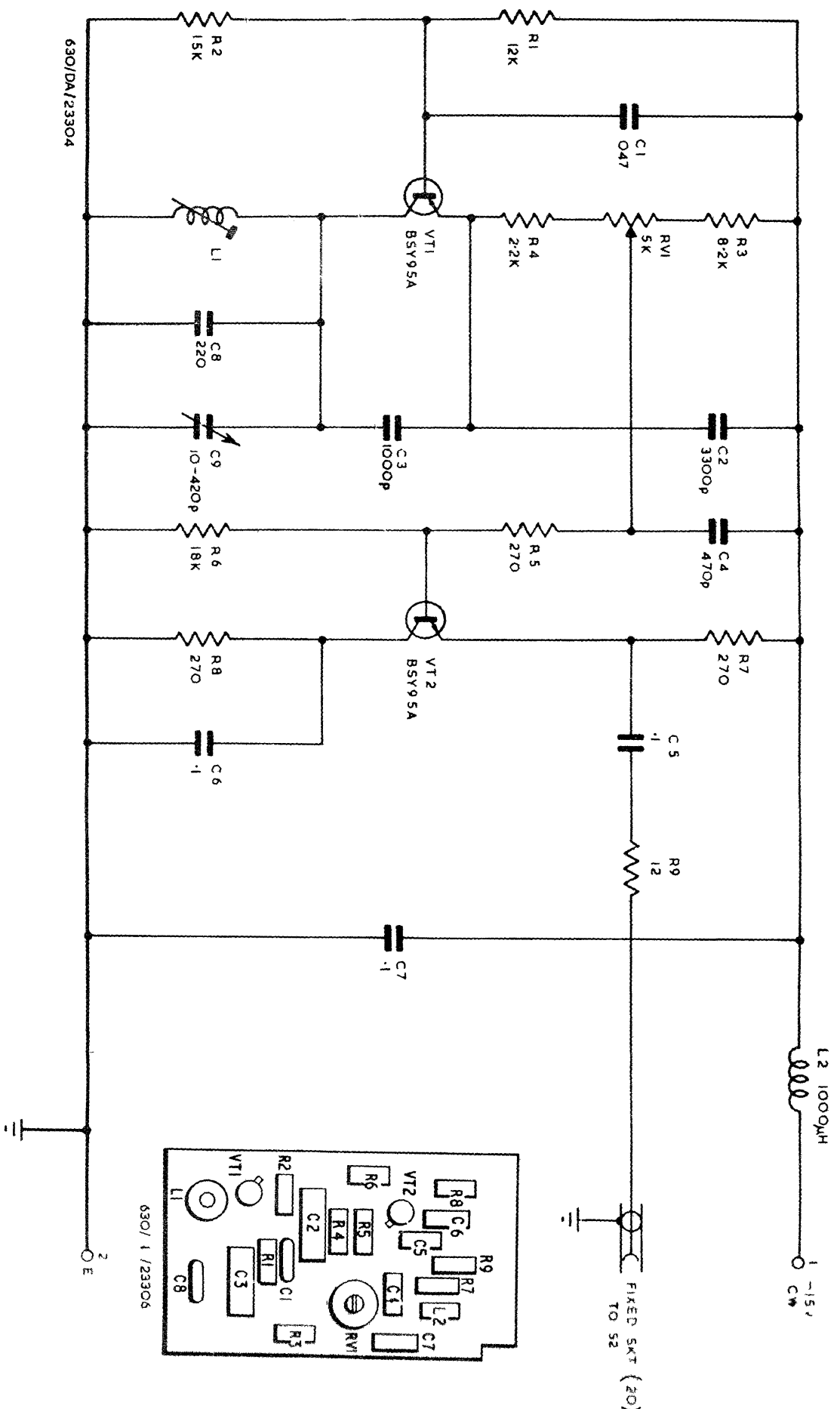

FIG.19 PRISS AUDIO AMPLIFIERS, MODULE 9 : CIRCUIT AND BOARD LAYOUT



Modification	Fig 20	Issue	8
1	2	3	4
5	6	7	8
9	10	11	12

FIG. 20 100k/c/s DIVIDER AND CALIBRATE CIRCUIT, MODULE 12: CIRCUIT AND BOARD LAYOUT



Modifications											
1	2	3	4	5	6	7	8	9	10	11	12

FIG. 21.

B.F.O. CIRCUIT AND LAYOUT

FIG. 21. 1.FO

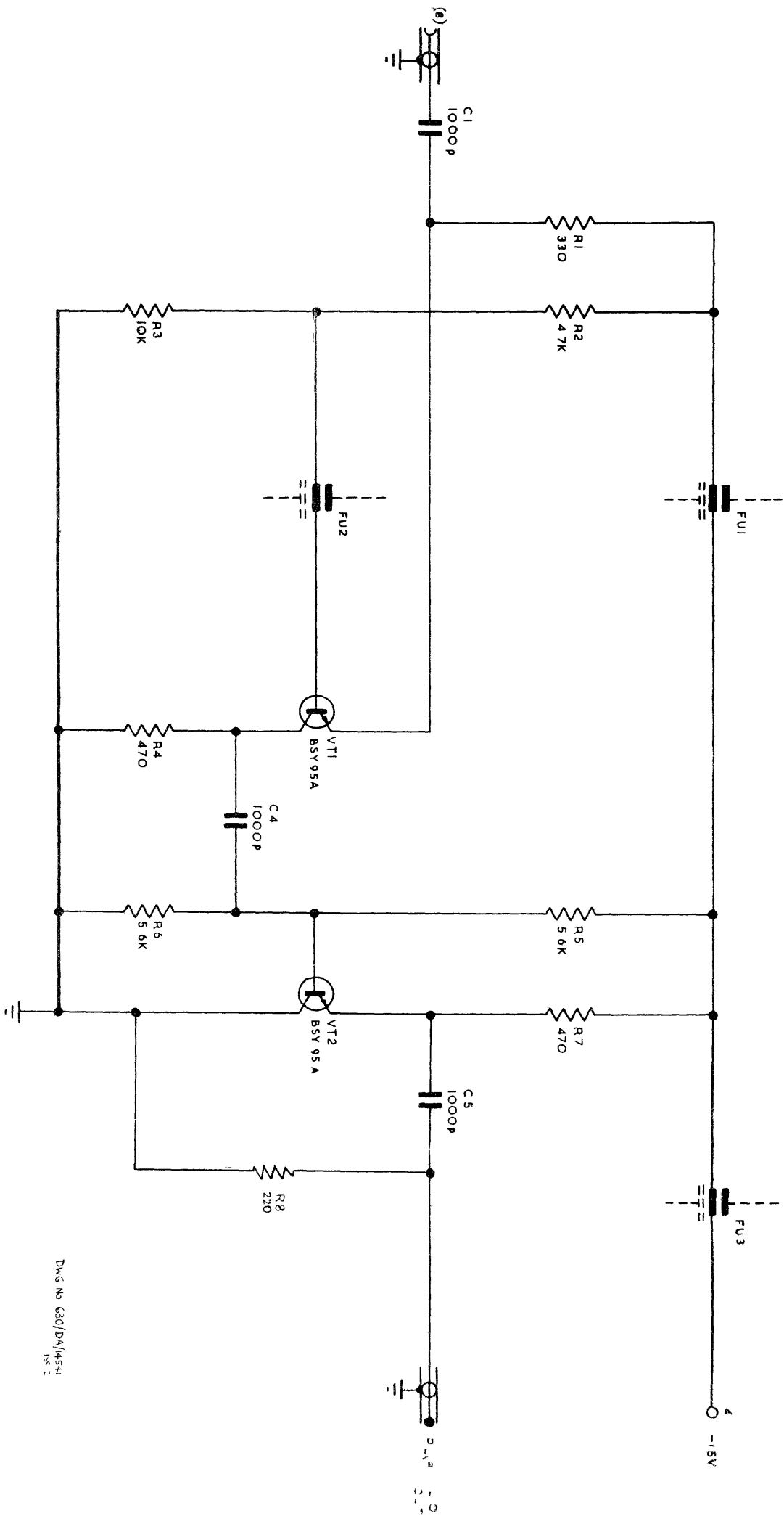
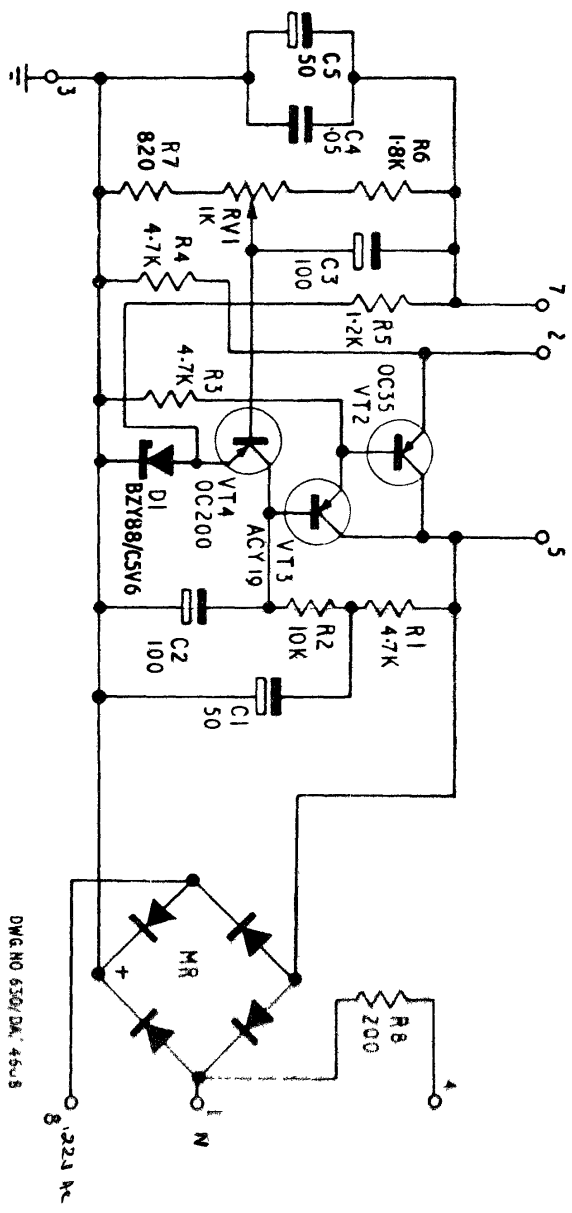
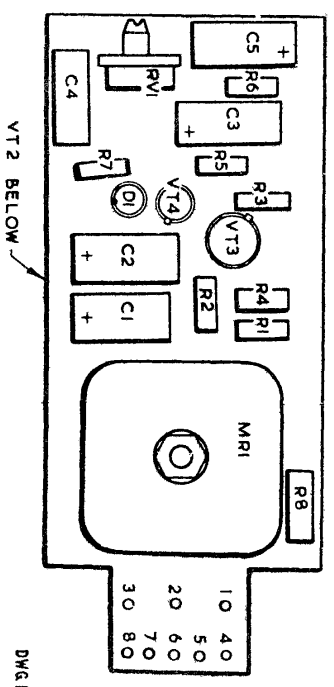

FIG. 22. ISOLATING AMPLIFIER : CIRCUIT

DWG NO 630/DA/454H
155 2



DWG NO 650/DK 4508



DWG NO. 650/1/4508

Modifications Fig 23 Issue 4											
1	2	3	4	5	6	7	8	9	10	11	12

FIG. 23 REGULATOR CIRCUIT AND LAYOUT.

FIG. 23 REGUL CR

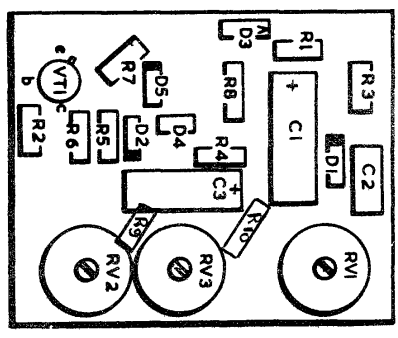
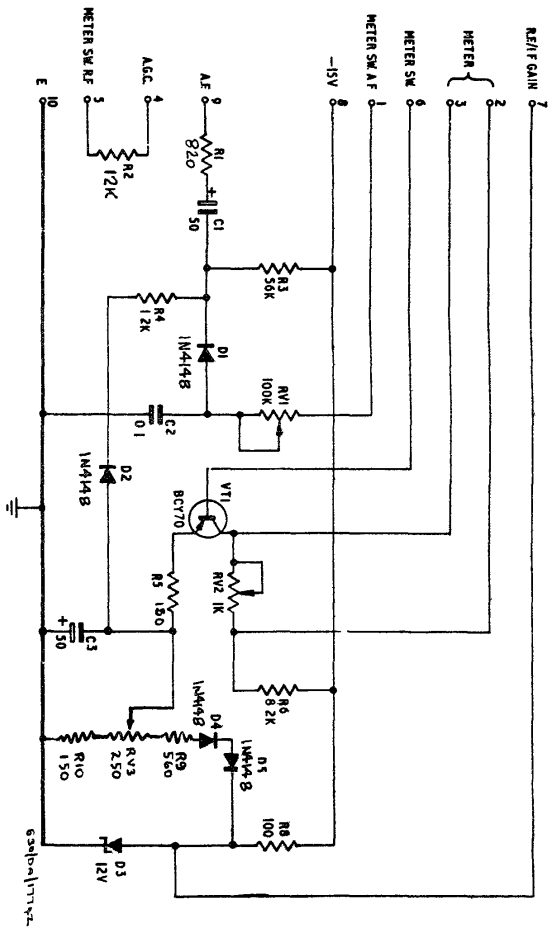

Modifications	Fig 24	Issue
1	4	5
2	5	6
3	6	7
4	7	8
5	8	9
6	9	10
7	10	11
8	11	12

FIG 24A: METER AMPLIFIER: CIRCUIT & BOARD LAYOUT

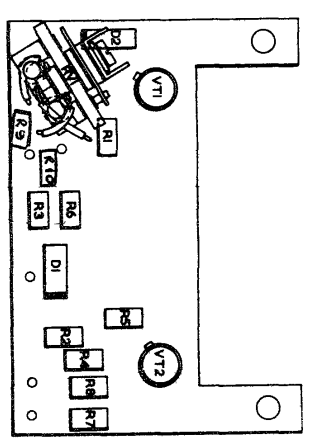
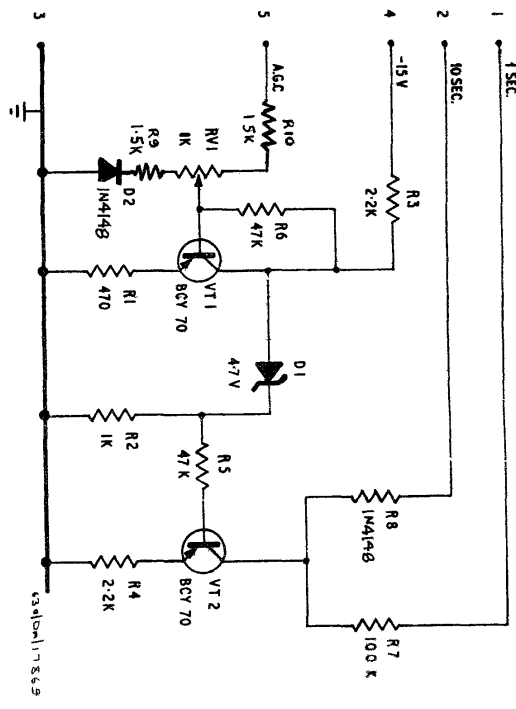

Modification	Fig	Issue
1	2	3
2	3	4
3	4	5
4	5	6
5	6	7
6	7	8
7	8	9
8	9	10
9	10	11
10	11	12

FIG 24B: A.C.C. DECAY SHAPER: CIRCUIT & BOARD LAYOUT